

077-32
364 4P.

N87-10496

6.16 PROGRESS IN THE MF RADAR SYSTEM AT SASKATOON

C. E. Meek and A. H. Manson

Physics Department
University of Saskatchewan
Saskatoon, Canada S7N0W0

SE 683460

18961

INTRODUCTION

Two improvements have been made to the radar system in the last year, one is the addition of O/X mode capability to the full antenna array used in the real-time wind system, and the other is the development of a coherent receiver -- a temporary arrangement until a fully engineered model is completed.

X-mode should be useful in reducing interference at night, and should also increase signal strength since the reflection coefficient is greater than O-mode and its absorption minimal. It was found that running O-mode in daytime resulted in a loss in data at lower heights, probably because of the reduced reflection coefficient, so the system was set to choose between linear N-S and X-mode (transmission is fixed linear N-S), alternating between X and linear every 5 min at night with a separate set of gains maintained and updated for each mode. Preliminary results (1 month) show negligible difference between the two, based on the number of wind values obtained. The reasons for this are still under investigation; possibly there are enough ionospheric absorption events to reduce the effectiveness of X-mode at this location.

The addition of a coherent receiver significantly expands the experimental capabilities of the system in terms of phase measurement for interferometer experiments (two papers in this proceedings), and coherent integration for extending the useful height range of the spaced antenna system downward. Also, it allows measurement of mean Doppler shift which can be used to determine vertical velocities. One such system has already been set up.

REAL-TIME V_z SYSTEM

Figure 1 shows a schematic diagram of the system. The transmitter antenna is also used for reception, resulting in a theoretical half beam width (3 dB) of 10° . Normal operation employs 4-point coherent integration (at 32 heights) giving a final Δt of 0.533 sec before accumulating autocorrelations (32-point integration can be done with a slight increase in Δt). Full 8-bit multiplication is used. Present selection criteria are fading rate (width of autocorrelation) and phase curvature near zero lag. It can be shown that the slope of the phase at zero lag is a weighted average of the radial velocity of the separate scatterers. A reasonable estimate of vertical velocity, V_z , should be obtained if scatterers are uniformly distributed in azimuth over the number of records averaged. At present, the records are 4.5 min long; this is not a system limit but is necessary so that the gain-height pattern, which is only set once for a record, can follow signal strength variations. Records can be almost as short as required -- a run of 90-sec records with 32-point integration has been done (but the number of heights analysed by the C64 has to be reduced for very short records). Figure 2 shows an example of hourly mean data from the system. At 85 km, data are a little erratic because it is one of the heights (every fourth) where a gain change is made when necessary.

COHERENT REAL-TIME WIND SYSTEM

Figure 3 shows a schematic of the proposed system. The maximum transmitter pulse rate is 60 Hz, which allows 32-point coherent integration when there is a receiver for each antenna. More importantly, the new receivers

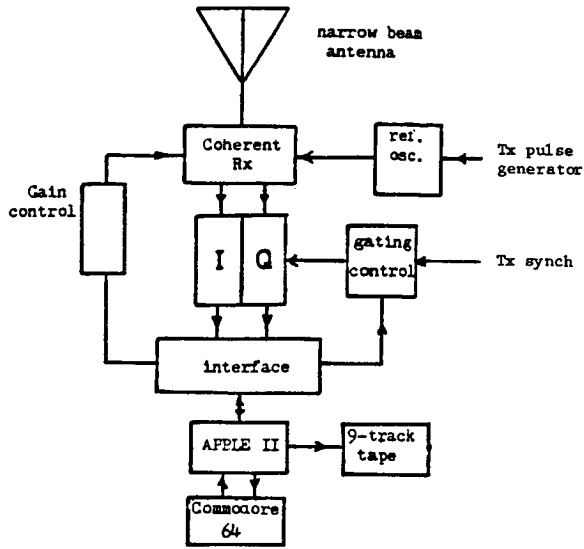

Figure 1. Schematic diagram of the real-time Vz system.

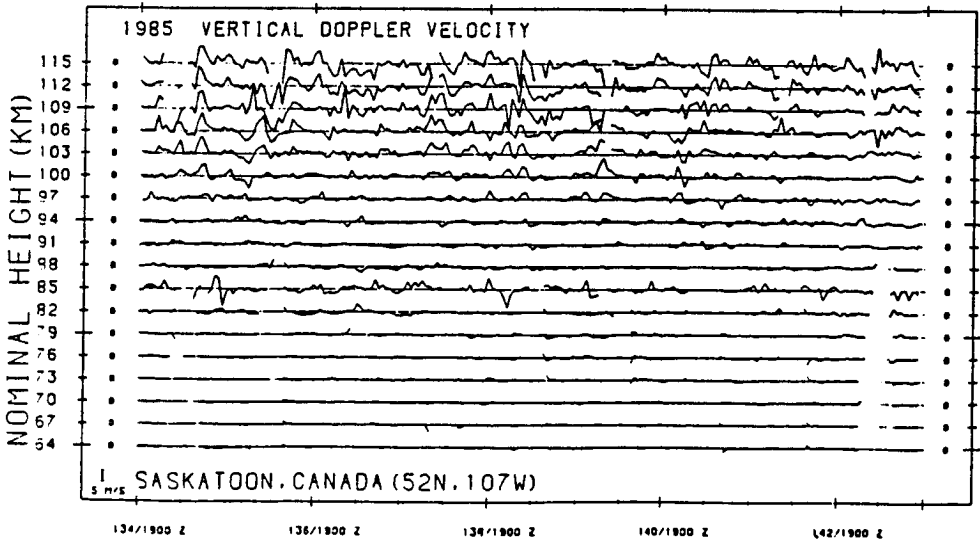

Figure 2. An example of hourly mean Vz data (from 4.5 min records).

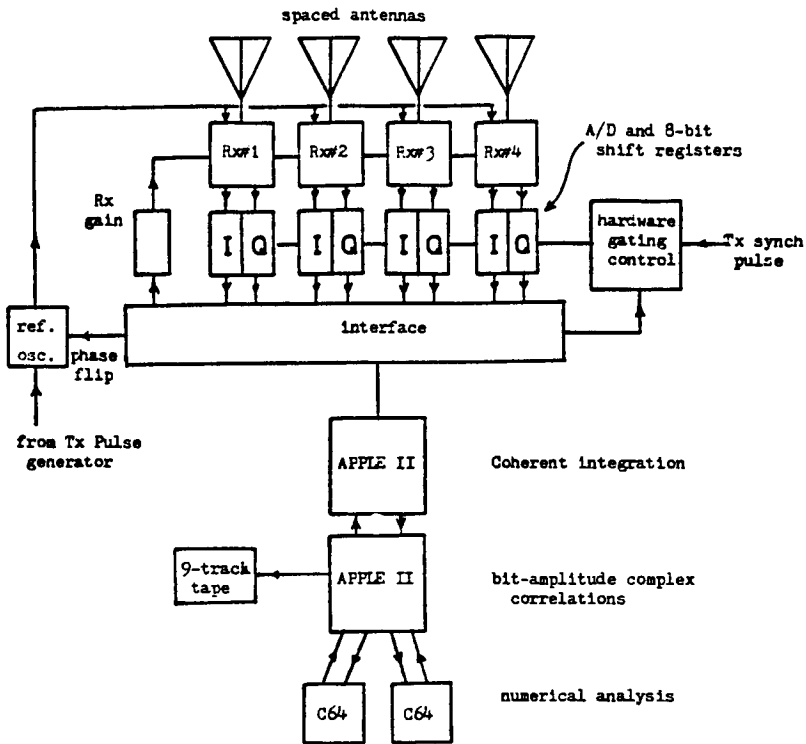

Figure 3. Schematic diagram of the proposed coherent real-time wind system.

will be able to change gain very rapidly, so that the best gain can be set for each height gate. (The present receiver gain control precedes the IF filter, and results in filter "ringing" with some loss of data at the height after a gain change; consequently the gain is set for groups of 4 heights, which means that only one height in four has optimum gain.)

Coherent integration will be done in software with a phase-flip system to remove dc offset, and the sign bit of the result kept to represent the amplitude -- giving an instantaneous conversion to binary sequences. A second microcomputer, probably an Apple, which appears to be marginally fast enough, will do the required auto- and cross correlations. Numerical analysis will probably require two Commodore 64s.

Figure 4 compares complex amplitude and complex bit amplitude correlations for one height. Three-point coherent integration was used. There is some minor degradation of the correlations when using bit amplitudes.

FABRY-PEROT INTERFEROMETER

The Institute has recently procured a new scanning Fabry-Perot system from D. Rees (U.K.); this operates under computer control, and partial real-time processing is incorporated. Filters including 630 nm (F region), 558 nm (F, E region) and OH bands (upper middle atmosphere) may be used, leading to atmospheric temperatures and winds. Special cooperative experiments with the MF radar are already planned to try to locate the height of the green-line emission; and using the OH data, relate thermal winds to temperatures, and gravity-wave effects to data from the radar "GRAVNET" system.

