

SAFETY HAZARDS ASSOCIATED WITH THE
CHARGING OF
LITHIUM/SULFUR DIOXIDE CELLS

by

H. Frank, G. Halpert, and D. D. Lawson
Jet Propulsion Laboratory
Pasadena, California

and

J. A. Barnes and R. F. Bis
Naval Surface Weapons Center
Silver Spring, Maryland 20903-5000

ABSTRACT

A continuing research program to assess the responses of spirally wound, lithium/sulfur dioxide cells to charging as functions of charging current, temperature, and cell condition prior to charging is described. Partially discharged cells that are charged at currents greater than one ampere explode with the time to explosion inversely proportional to the charging current. Cells charged at currents of less than one ampere may fail in one of several modes. The data allow an empirical prediction of when certain cells will fail given a constant charging current.

INTRODUCTION

For several years, the Lithium Systems Safety Group at the Naval Surface Weapons Center has been concerned with the behavior of lithium batteries under abusive conditions. In fact, the Navy's safety test program for equipment containing lithium batteries focuses on abusive experiments. (1-4)

At first, these experiments concentrated on physical abuse, internal and external short circuits, and cell voltage reversal. More recently, we have identified the charging of a lithium battery as another potentially hazardous situation which can occur in equipment containing one of the following circuits as shown in Figure 1: (1A) a single series string of cells in parallel with an external source of power, (1B) several equivalent strings of cells in parallel with each other, and 1C) a string of cells in a piece of equipment which contains another source of current.

Blocking diodes should always be installed in the first two situations in order to reduce the hazard. If the diodes function properly, only very low levels of leakage current will be available to charge the cells. If the diodes fail or are omitted from the circuit, significant charging currents can

PRECEDING PAGE BLANK NOT FILMED

occur. In the third situation, protective diodes are not normally used because the cells should never be connected to any source of charging current; but wiring errors or equipment failure may allow such a connection with the subsequent charging of a lower voltage string by a higher voltage source. In each of these cases, the charging current obtained will be a function of the difference in the voltages of the charging source and the receiving battery and of the design and condition of the battery.

Because of this concern about the dangers of possible charging, the Lithium Systems Safety Group has funded a joint research program with the Jet Propulsion Laboratory of the California Institute of Technology to characterize the effect of charging on lithium cells. In addition, the program should help to identify the conditions where charging of lithium cells may produce severe safety hazards, and to propose chemical and/or physical mechanisms to explain the effects of charging. Because of limitations on funding and staff, this program has focused on the cells in widest use within the Navy--high rate (lithium rich), spirally wound, lithium/sulfur dioxide cells in "C," "D," and similar sizes. Additional, less extensive work has been done on "balanced" lithium/sulfur dioxide cells and on several lithium/thionyl chloride systems. In all of the systems investigated we have always observed behaviors which are at least qualitatively the same as those reported in this paper.

EXPERIMENTAL

The cells employed in this investigation were obtained by dismantling spare sonobuoy battery packs as shown in Figures 2 and 3. These particular batteries and cells were manufactured by Duracell in 1981 and were kept in storage at room temperature until shipped to JPL by the Navy in 1983. The cells were approximately four years old at the beginning of the current experiments. Except for test loads applied during manufacture, the batteries have not been discharged.

The cells under study are Duracell lithium/sulfur dioxide type L030SH. They are of the spirally wound configuration, are slightly smaller than a standard "D" size, contain excess lithium, and have a rated capacity of 4.3 Ampere hours at the "C/2" discharge rate at 21°C to a 2.0 volt limit.

All charging tests were carried out with power supplies. In each case, the supplies were adjusted to provide a constant current; voltages were allowed to "float." No diodes or other protective devices were included in the circuits. Strain gages mounted to the exterior of the cells were used to estimate the internal cell pressures. The gages were calibrated by pressurizing cell cans with argon gas. This calibration method allows the measurement of pressure changes within the cell relative to the initial pressure when the gage was installed at ambient temperature. The accuracy of long-term pressure measurements made with this technique may be limited by the calibration procedure which did not include experiments to identify any effects which aging might have on the gages or creep of their bonding agent, ethyl cyanoacrylate; therefore the calculated pressures, after long periods, may not be accurate.

Except where noted, all cells were discharged by 20% (80% of capacity remaining) through a resistive load of 36 ohms (80 mA) before charging. The cells sat on open circuit for at least one week after discharge before being charged. The charging tests were divided into three major groups designated as low, medium, and high rate. These differed from each other in the magnitude of charging current, number of cells, and few other details. A description of each of these is given below.

HIGH RATE CHARGING TESTS

These tests were conducted on single cells inside a large (4 feet x 4 feet x 8 feet), steel lined chamber. Experiments were run at three currents, 1.0, 5.0, and 10.0 Amperes, and at three temperatures, ambient, -20 and +70°C. The low and high temperatures were maintained with a freezer and an oven located inside the large test chamber. In most cases the tests were run three times for each condition of current and temperature. The cells were always instrumented with voltage probes and thermocouples and in some cases with strain gage pressure transducers. Voltages, temperatures, and pressures were recorded with strip chart recorders.

INTERMEDIATE RATE CHARGING TESTS

These tests were carried out on two groups of two series connected cells at currents of 100 and 300 mA. All the tests were run at ambient temperatures inside a steel vessel located in a test area outside a laboratory building. Each of the cells was instrumented with voltage probes, one thermocouple, and a strain gage pressure transducer. Voltages, temperatures, and pressures were recorded with strip chart recorders.

LOW RATE CHARGING TESTS

These experiments were conducted in an isolated laboratory. A matrix of 27 different conditions was established to study the effects of variations in charging rate, temperature, and original cell condition. Each block of the matrix was represented in the experimental program by a single cell. (Duplicate experiments are now being planned.) Nine fresh cells were used as received; nine cells were discharged by 50% through a 36 ohm load; and the remaining nine cells were similarly discharged by 80% (20% of capacity remaining) before beginning the charging experiments. These cells were redivided to yield sets of nine cells containing three cells of each discharged type. These sets were charged at currents of either 0.1, 1.0, or 10.0 mA. The cells were placed in temperature-controlled chambers at -20, +35, or +70°C. One cell of each discharge type and charging rate was tested at each temperature. In order to minimize the number of power supplies required for this long-duration experiment, all of the cells being charged at a given rate were wired in series. A schematic of this experimental matrix is shown in Figure 4. Each of the cells was instrumented with voltage probes and with a strain gage type pressure transducer. Individual cell voltages and pressures were recorded with a Hewlett-Packard data logger. Also the three currents and chamber temperatures were recorded. Data were recorded at half hour intervals for the first several days of the experiment. Then the

recording rate was reduced to once every six hours. When a cell became inoperative, it was manually removed from the temperature chamber and from the circuit; the experiment was restarted on the remaining cells in the affected string. Safety considerations required a "waiting period" of several days after cell failure before conducting the removal and restarting procedures. For this reason, there were several interruptions in this test program.

RESULTS AND DISCUSSION

RESULTS OF HIGH RATE CHARGING

Initial efforts were focused on high rate charging tests at 10 Amperes with the cells at ambient temperature. If the cells were undischarged, they failed with "violent ventings." If they had been partially discharged, they consistently exploded within 5 to 15 minutes after the onset of charging. (If all parameters were carefully controlled, the time before an explosion would not vary more than a few seconds from sample to sample.) These explosions are substantially more severe than the violent ventings normally associated with charging undischarged cells. External cell temperature and internal pressure begin to rise quite rapidly just before cell failure. Strain gage measurements indicate that the explosion is always preceded by a sudden drop in internal cell pressure as would be expected from the cells venting shortly before the explosion. These ventings could be heard from outside the test chamber just prior to the explosions. Typical behavior of the cells during these high rate tests is shown in Figure 5. The explosion typically followed cell venting within half a minute.

Subsequent charging tests at ambient temperature and reduced currents of 5 and 1 Amperes revealed similar behavior. In these cases the cells also consistently exploded. The charging time required to produce the explosion increased as the charging current decreased. These findings suggest at least some correlation between time to explosion and charging current.

The high rate tests were continued by repetition of the runs at ambient temperature and by additional experiments at both high (+70°C) and lower (-20°C) temperatures. The cells consistently exploded at both the high and low temperatures, and the times to explosion were comparable to those times for cells charged at similar rates; there was no clearcut effect of temperature on the time to explosion. These data are shown in Table 1.

RESULTS OF INTERMEDIATE RATE CHARGING

The purpose of the intermediate rate charging tests was to obtain data for the region between the lowest of the high rate tests at 1.0 Ampere and the highest of the low rate tests at 10 mA. These tests used two groups of two series connected cells at ambient temperature. One group was charged at 100 mA and the other at 300 mA. For safety reasons, the cells were located inside the steel vessel mentioned earlier. The cells have now been on test for almost 100 days. One of the two cells being charged at 100 mA failed after 41 days; the temperature and pressure data indicate that the failure was similar to the explosions observed at higher rates. The failure disconnected

the leads from the other cell in series with the failed one. Because the test chamber contains two cells which are being charged at 300 mA, safety considerations prevent us from entering it to reconnect the circuit or to examine the failed cell. The test on the other two cells was not interrupted by the nearby failure and is still in progress. Data for one of these cells are given in Figure 6. Note that the current has held constant at 300 mA while the voltage has increased from the 3.0 to the 4.0 volt level and the pressure has reached an apparent plateau about 80 pounds per square inch (psi) above the initial cell pressure. This test will be continued.

RESULTS OF LOW RATE CHARGING

Based on early projections from the high rate tests, we anticipated that there would be a period of at least several months before cells charged at low rates would exhibit any type of venting or explosion. For this reason, the low rate charge tests were begun early in the program and are continuing at the present time.

As of October 1985, the cells have been charged at the indicated currents of 0.1 to 10.0 mA for nearly 200 days. During this period, there have been no ventings or explosions of any of the 27 cells. The lack of explosions during the first 200 days of these low current tests is in agreement with the empirical safety map to be discussed later. Although the cells under low rate test have not yet exhibited any explicit safety hazards, the tests have yielded other pertinent data. After a period of one month, the power supply voltages applied across some cells began to rise from the 3 - 4 volt level to nearly 30 volts (the limit of the power supplies) while the current flowing through the string dropped to near zero. This behavior suggested that an open circuit condition had developed within the cells. In each case, the faulty cell was identified and manually removed after a "safety period" of several days. The remaining cells were returned to charging, but the removed cells were not replaced. X-ray examination of these faulty cells revealed the loss of the internal aluminum tab which connects the cathode to the center pin, as shown in Figure 7. So far, five cells have exhibited this open condition and have been removed from the test. All five were at 70°C, and three of these were at the highest current of 10 mA. These observations suggest the occurrence of an internal corrosion process. The rate of which increases with temperature and charging current and/or applied voltage.

The internal pressures of the cells and the variation of these pressures with the time on charge are also of interest. The accuracy of the following observations may be limited by the strain gage calibration procedure discussed earlier. After charging began, the cell pressures dropped briefly before increasing to a plateau over a period of several months. These plateaus, or steady state pressures, increase with temperature for a given current; but there does not seem to be any correlation with current for a given temperature. After 180 days, the average pressures of the cells remaining on test are about 300, 10, and -10 psi relative to starting pressures at temperatures of 70, 30, and -20°C respectively. Pressures of two cells at 70°C have reached about 500 psi; these pressures are near (or possibly in excess) of the nominal venting pressure of 450 +/- 50 psig for these cells.

An example of these data is given in Figure 8. This figure shows the current, voltage, and pressure for a cell that was charged at 1.0 mA at 70°C. The indicated interruption in the current was caused by the failure of another cell in the series string and the subsequent bypassing of this "open cell." Note that the pressure of this particular cell has apparently reached a plateau near 500 psi. Even given the limitations on the pressure measurements discussed earlier, the pressure in this cell has been quite high and has approached the pressure at which it would vent.

This program of low rate charging will be continued.

SAFETY ENVELOPE

A tabulation was made of all of the times to explosion for each of the charging currents. These results were plotted both with linear scales and with a logarithmic scale for time and a linear scale for current. The latter curve is given in Figure 9 for currents from 1 to 10 Amperes. This curve indicates that for a given set of conditions--cell type, discharge history, and charging current--there seems to be a specific time threshold which separates "acceptable" and very dangerous charging. The time required to reach a dangerous condition increases as the charging current is reduced. Unfortunately, this threshold is a function of many variables. No model yet exists which will allow the reliable prediction of the dangerous region for a system without first conducting extensive experimental measurements. Therefore, any charging of a lithium/sulfur dioxide cell, even at low currents, must be regarded as potentially hazardous and should always be avoided.

FUTURE EFFORTS

The results which we have reported are part of a continuing program. Future work will be directed towards development and validation of a physical-chemical model to explain the observed phenomena. Experiments will include electrical, thermal, and chemical investigations (including autopsies) on cells of the same type as currently under test. The program will be expanded to other sizes of cells from several manufacturers in order to develop a family of "safety maps" and in an effort to confirm the general nature of the observed behavior.

ACKNOWLEDGEMENT

The research described in this paper was carried out by the Jet Propulsion Laboratory, California Institute of Technology, under a program sponsored by the U. S. Navy through an agreement with the National Aeronautics and Space Administration.

REFERENCES

1. Naval Sea Systems Command, Notice 9310 of 11 June 1985.
2. R. F. Bis and J. A. Barnes, "Policies Governing the Use of Lithium Batteries in the Navy," The 1982 Goddard Space Flight Center Battery Workshop, NASA CP 2263, p. 23 (1983).

3. J. A. Barnes, et al., "Testing of Candidate Batteries for Global Positioning System," The 1983 Goddard Space Flight Center Battery Workshop, NASA CP 2331, p. 159 (1984).
4. J. A. Barnes, et al., "High Rate Discharge Studies of Li/SO₂ Batteries," Ibid.

Table 1. TIMES TO EXPLOSION DURING CHARGING

Temp (°C) \ Current (Amps)	1	5	10
Ambient	47 hr 113 hr 27 hr	16 min 48 min 29 min	8 min 14 min 14 min 12 min 7 min 15 min 8 min
-20°C	89 hr	52 min 52 min 51 min 45 min	17 min 11 min
+70°C	104 hr 6 hr 146 hr	63 min	21 min 22 min

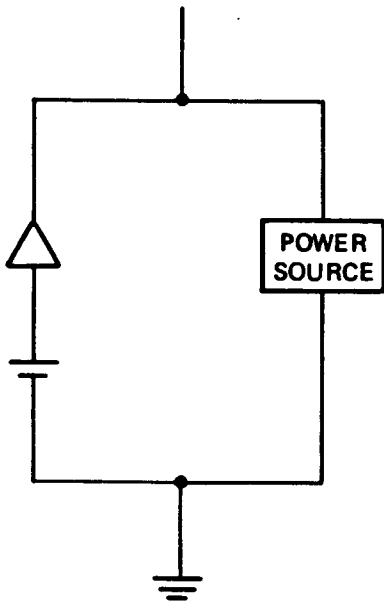

1A. SINGLE SERIES STRING OF CELLS IN PARALLEL WITH AN EXTERNAL POWER SOURCE

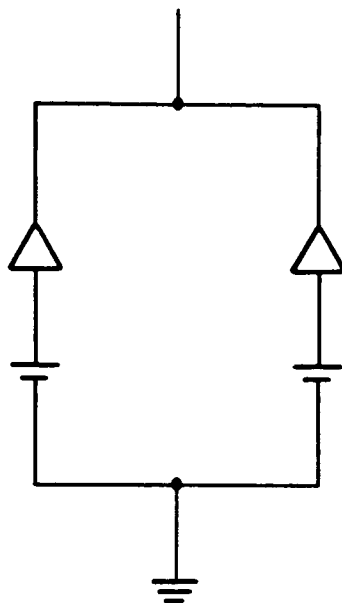

1B. SEVERAL STRINGS OF CELLS IN PARALLEL WITH EACH OTHER

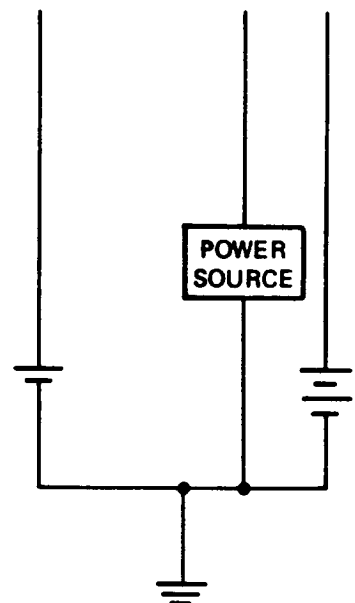

1C. A STRING OF CELLS IN EQUIPMENT THAT CONTAINS ANOTHER SOURCE OF CURRENT

Figure 1. CIRCUITS IN WHICH CHARGING CAN TAKE PLACE

ORIGINAL PAGE IS
OF POOR QUALITY

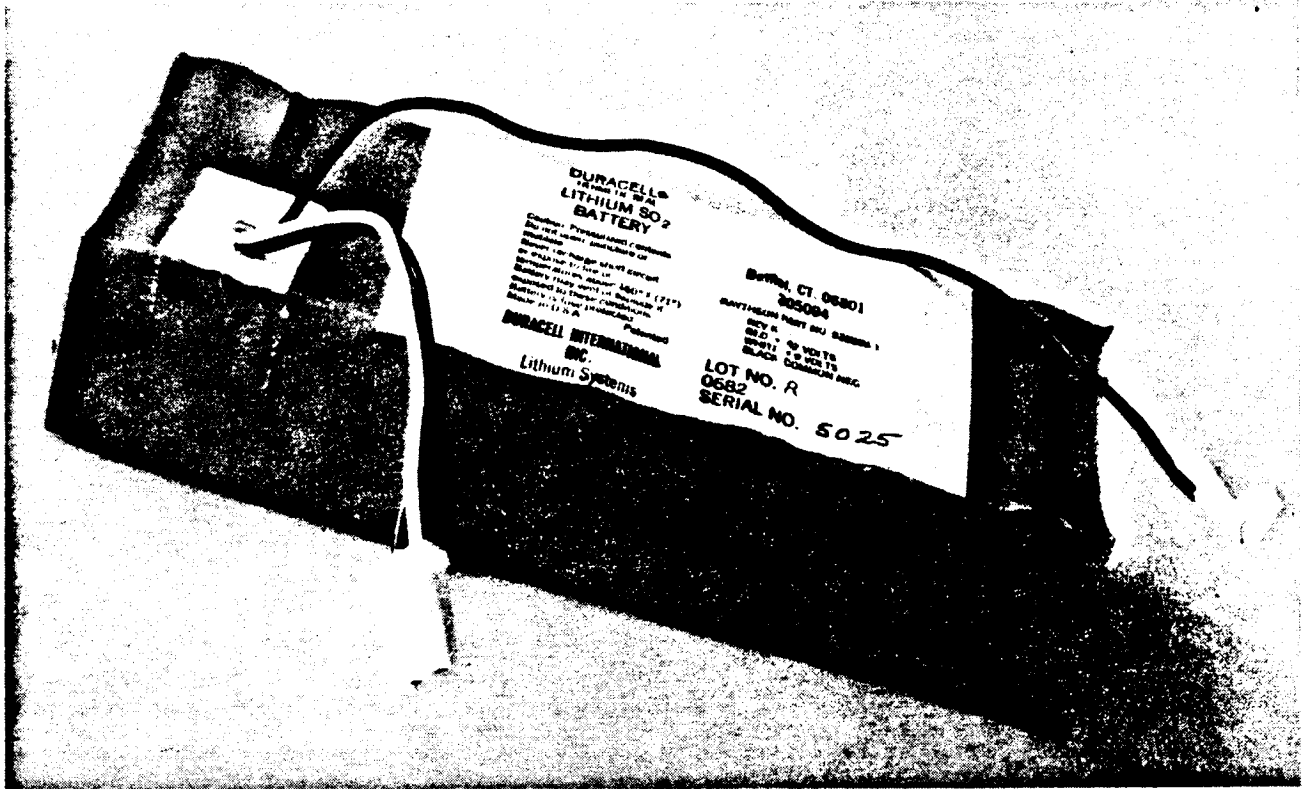

Figure 2. PHOTO OF SONOBUOY BATTERY PACK WITH COVER

ORIGINAL PAGE IS
OF POOR QUALITY

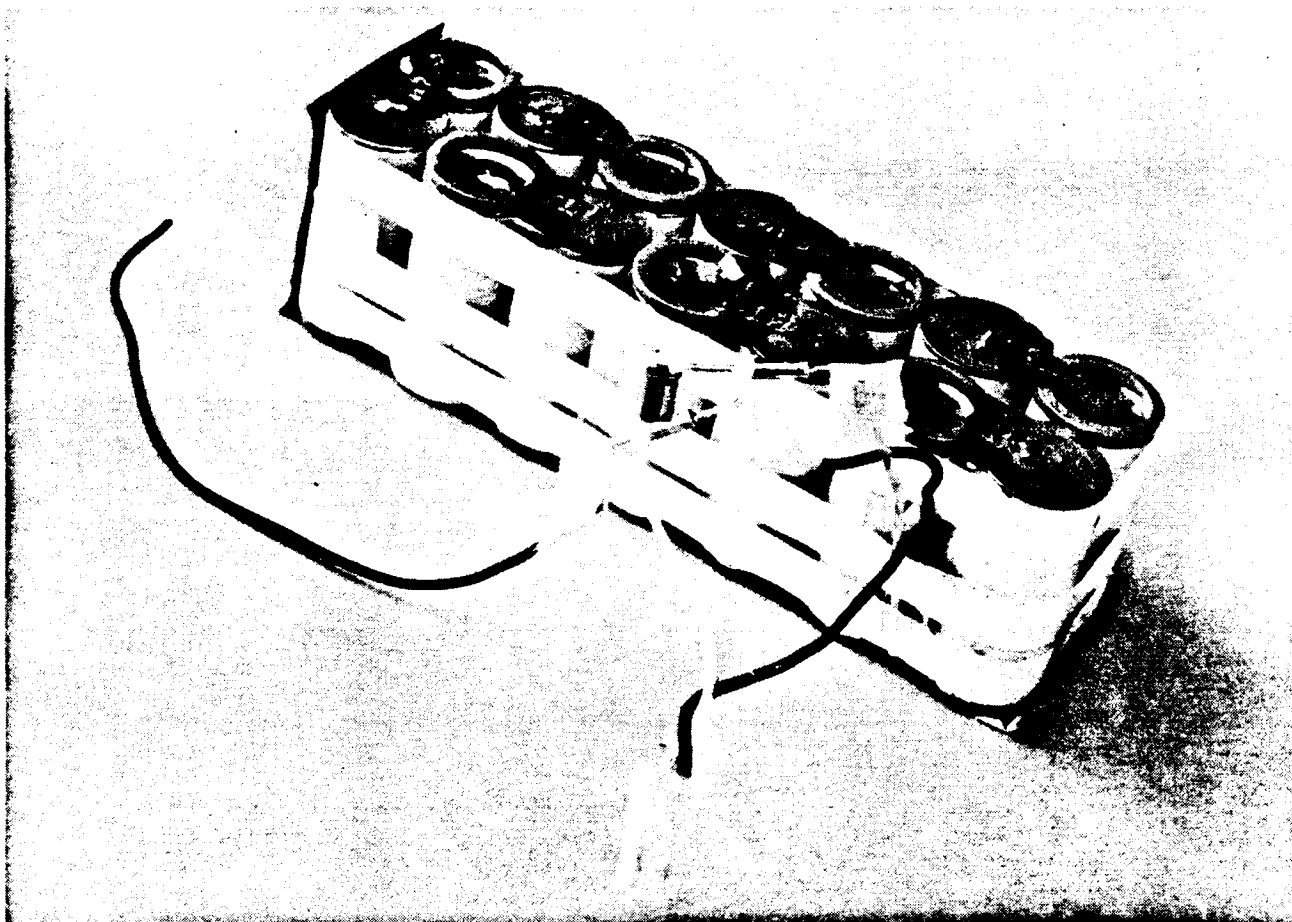

Figure 3. PHOTO OF SONOBUOY BATTERY PACK WITHOUT COVER

70°C			30°C			-20°C			
07 	08 	09 	17 	18 	19 	27 	28 	29 	10 ma
06 	05 	04 	16 	15 	14 	26 	25 	24 	1 ma
03 	02 	01 	13 	12 	11 	23 	22 	21 	0.1 ma
100% SOC	50% SOC	20% SOC	100% SOC	50% SOC	20% SOC	100% SOC	50% SOC	20% SOC	

Figure 4. MATRIX FOR LOW RATE CHARGE TESTS

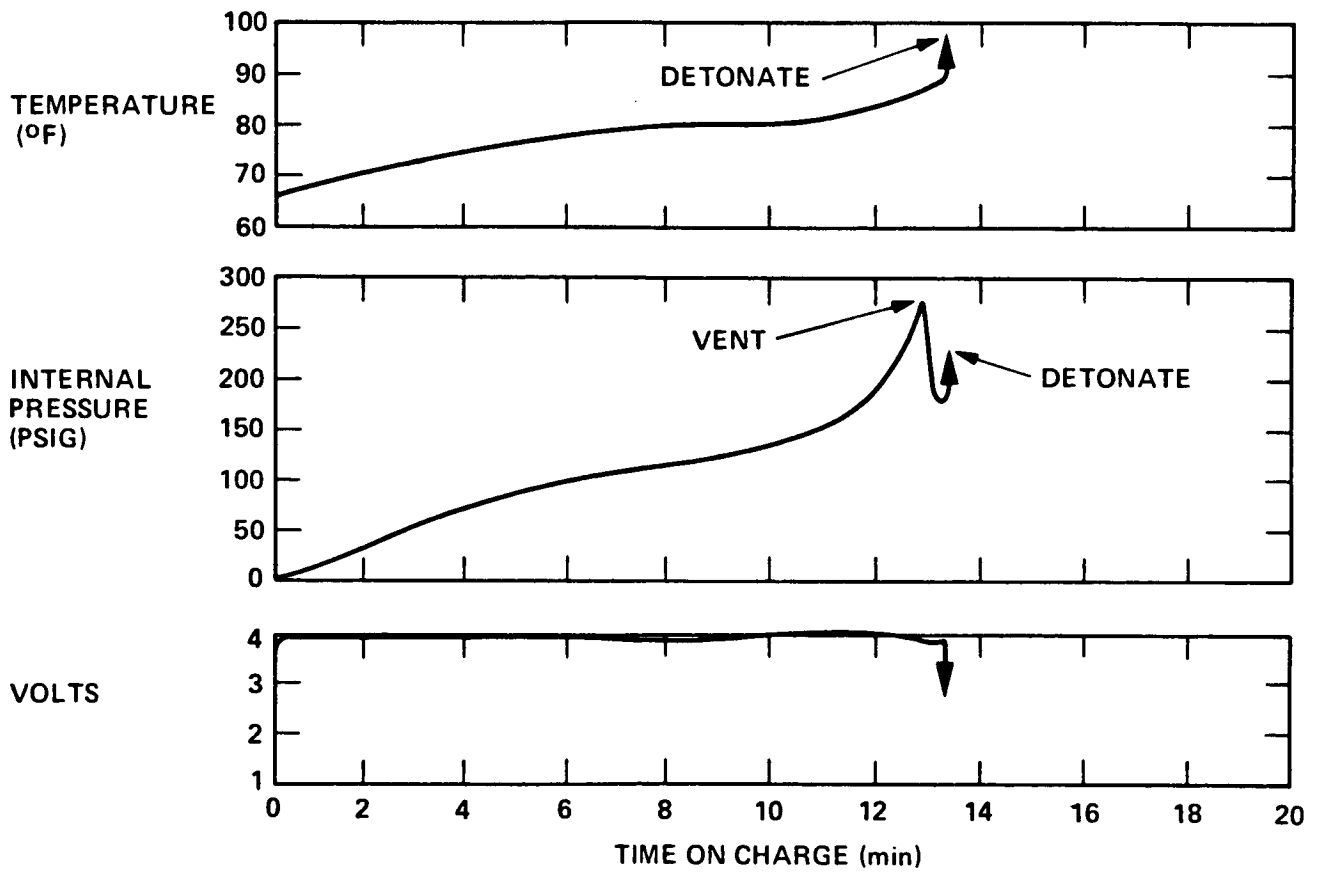

Figure 5. CELL CHARACTERISTICS DURING HIGH RATE CHARGE
 I = 10 AMPS, T = AMBIENT

C-2

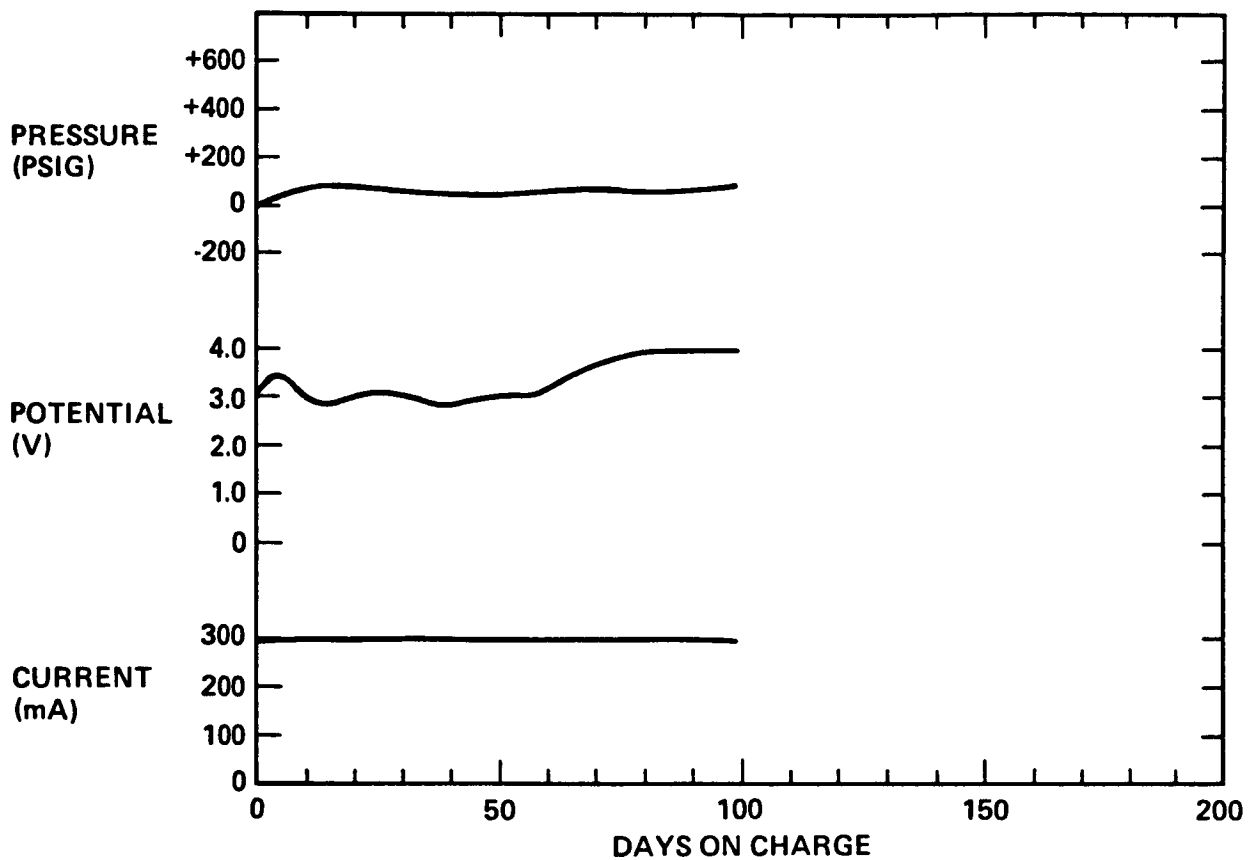
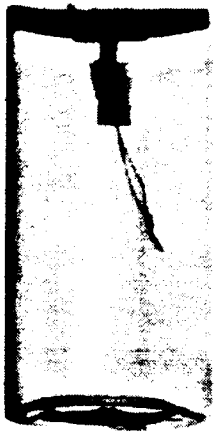

Figure 6. CELL CHARACTERISTICS DURING MEDIUM RATE CHARGE
 I = 300 mA, T = AMBIENT

ORIGINAL PAGE IS
OF POOR QUALITY

TYPICAL CELL
BEFORE CHARGE



CELL NO. 08 AFTER 34
DAYS AT 10 mA AT 70⁰C



NOTE LOSS
OF TAB

Figure 7. X-RAY PHOTOGRAPH OF OPENED CELL FROM LOW RATE CHARGE TEST

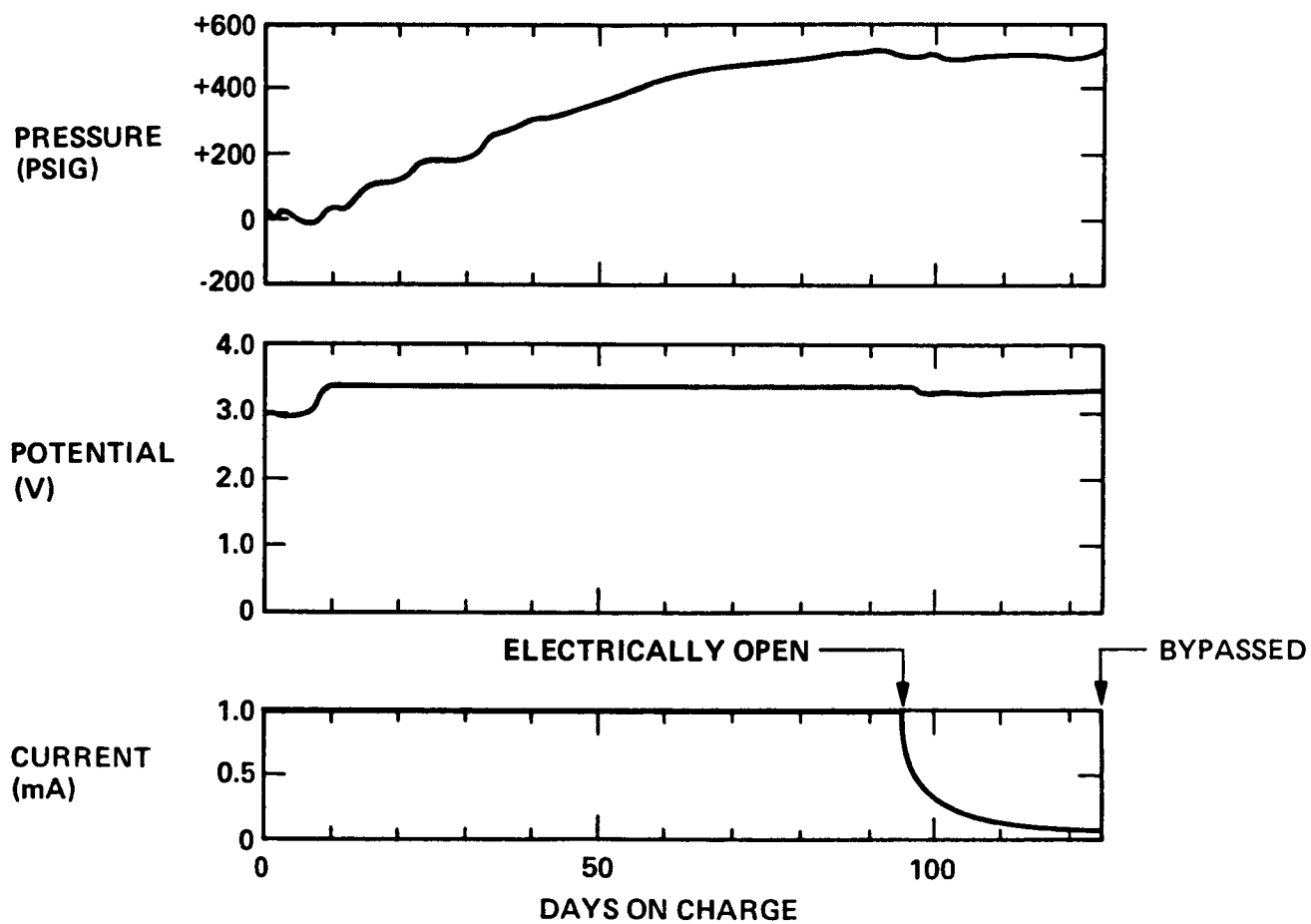

Figure 8. CELL CHARACTERISTICS DURING LOW RATE CHARGE
 $I = 1.0 \text{ mA}$, $T = 70^\circ\text{C}$

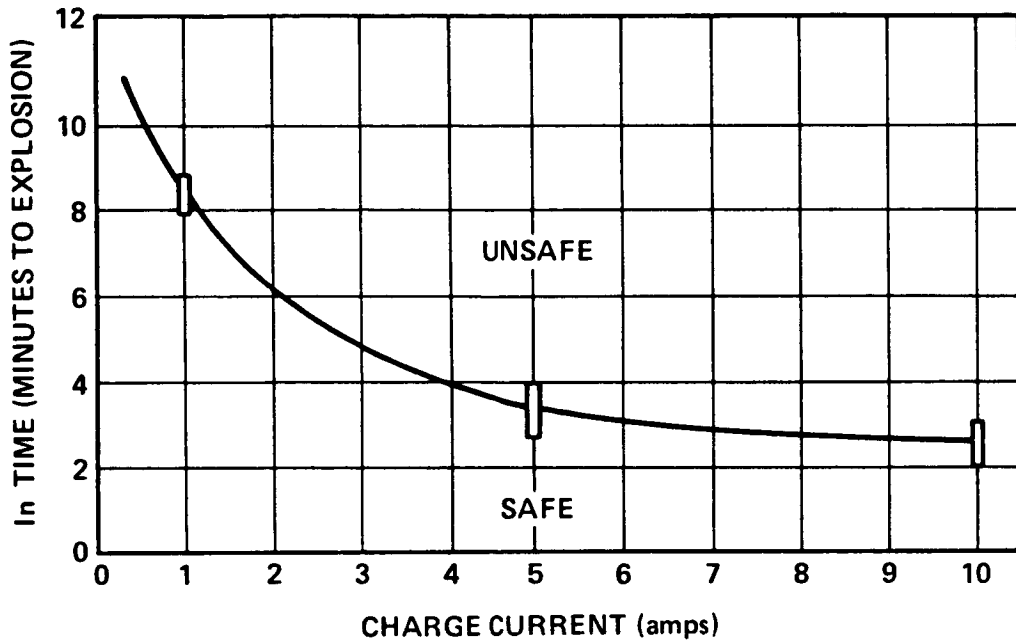

Figure 9. SAFETY ENVELOPE FOR CHARGING (Lo 30SH Li/SO₂ CELLS)