

N87-11718

STRUCTURAL SYNTHESIS -  
PRECURSOR AND CATALYST

L. A. Schmit  
University of California, Los Angeles  
Los Angeles, California

## STRUCTURAL SYNTHESIS PROBLEM STATEMENT

Almost 25 years have elapsed since it was recognized that a rather general class of structural design optimization tasks could be posed as nonlinear mathematical programming problems (Ref. 1). Figure 1 shows the nonlinear programming problem statement and its geometric interpretation in terms of a hypothetical two-dimensional design space plot. The use of inequality concepts is essential to the proper statement of most design optimization problems because at the outset it is not usually known how many or which constraints will be critical at the final design. In other words, the design drivers are not known with certainty in advance. In a structural context the constraints represented by Eq. 1 usually include: (A) one behavior constraint for each failure mode in each load condition; (B) side constraints that introduce fabrication and analysis validity limitations as well as "rules of thumb." Posing the structural design optimization task as a nonlinear programming problem makes it possible to consider: multiple load conditions; a wide variety of failure modes (e.g. limitations on stress, strain, displacement, buckling load, natural frequencies, etc.); side constraints; and objective functions other than weight minimization. During the past two decades a great deal of effort has been devoted to learning how to solve the structural synthesis problem efficiently for systems of practical interest. The main theme of this presentation will be to suggest that many of the key ideas that have helped advance the state of the art in structural synthesis may provide useful guidelines for the development of analysis and design tools in other disciplines.

Given the pre-assigned parameters and the load conditions

find the vector of design variables  $\vec{D}$  such that

$$g_q(\vec{D}) \geq 0 ; q \in Q \quad (1)$$

and

$$M(\vec{D}) \rightarrow \text{Min} \quad (2)$$

where

$$\vec{D}^T = [D_1, D_2 \dots D_I] \quad (3)$$

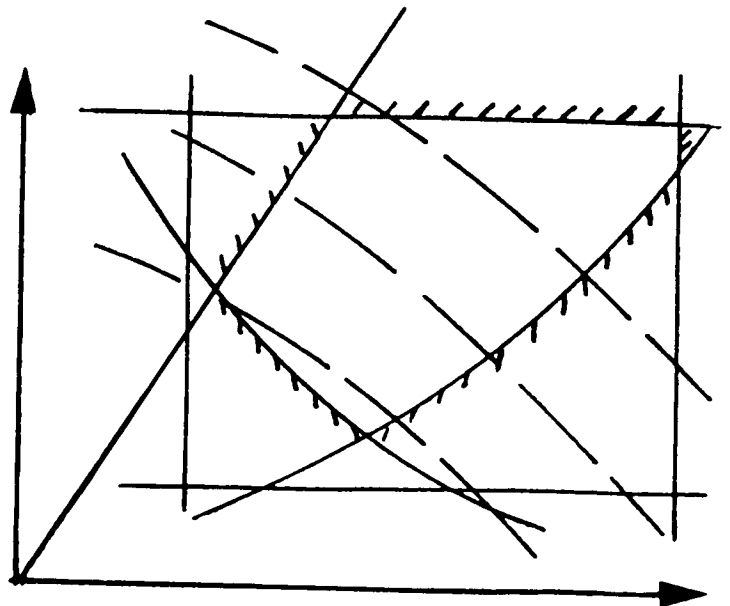

Figure 1

### STRUCTURAL COMPONENT SYNTHESIS (1968)

During the 1960's the structural synthesis concept was successfully applied to structural components of a fundamental and recurring nature (e.g. stiffened plates (see Ref. 2 and 3) and stiffened cylindrical shells (see Ref. 4 and 5)). The structural synthesis capability reported in Ref. 5 for minimum weight optimum design of integrally stiffened cylindrical shells (see Fig. 2a) was state of the art in 1968. In a philosophical sense, it was a precursor of the approximation concepts approach that was to emerge during the 1970's. This problem involved seven design variables (see Fig. 2b), multiple load conditions ( $N_k, p_k, \Delta T_k$ ), a rather extensive set of strength and buckling failure modes, and minimum gage and other side constraints. The mathematical programming problem statement was transformed into a sequence of unconstrained minimizations using the Fiacco-McCormick interior penalty function formulation (see Eq. 4, 5 and 6). The constraint repulsion characteristic of this penalty function formulation leads to a sequence of non-critical designs that tend to "funnel down the middle" of the feasible region in design space (see Fig. 2c). This observation led to the idea that approximate analyses could be used during each unconstrained minimization stage, with good expectations that the sequence of designs generated would remain in the actual feasible region. By doing a complete buckling analysis at the beginning of each stage and retaining only the critical and potentially critical mode shapes during each unconstrained minimization, computational efficiency was improved by a factor of 75 while still generating a sequence of positive margin designs with decreasing weight. Dynamically updated constraint deletion techniques that retain only design drivers and potentially critical constraints have and will continue to play an important role in the development of optimum design capabilities for structures as well as multidisciplinary systems.

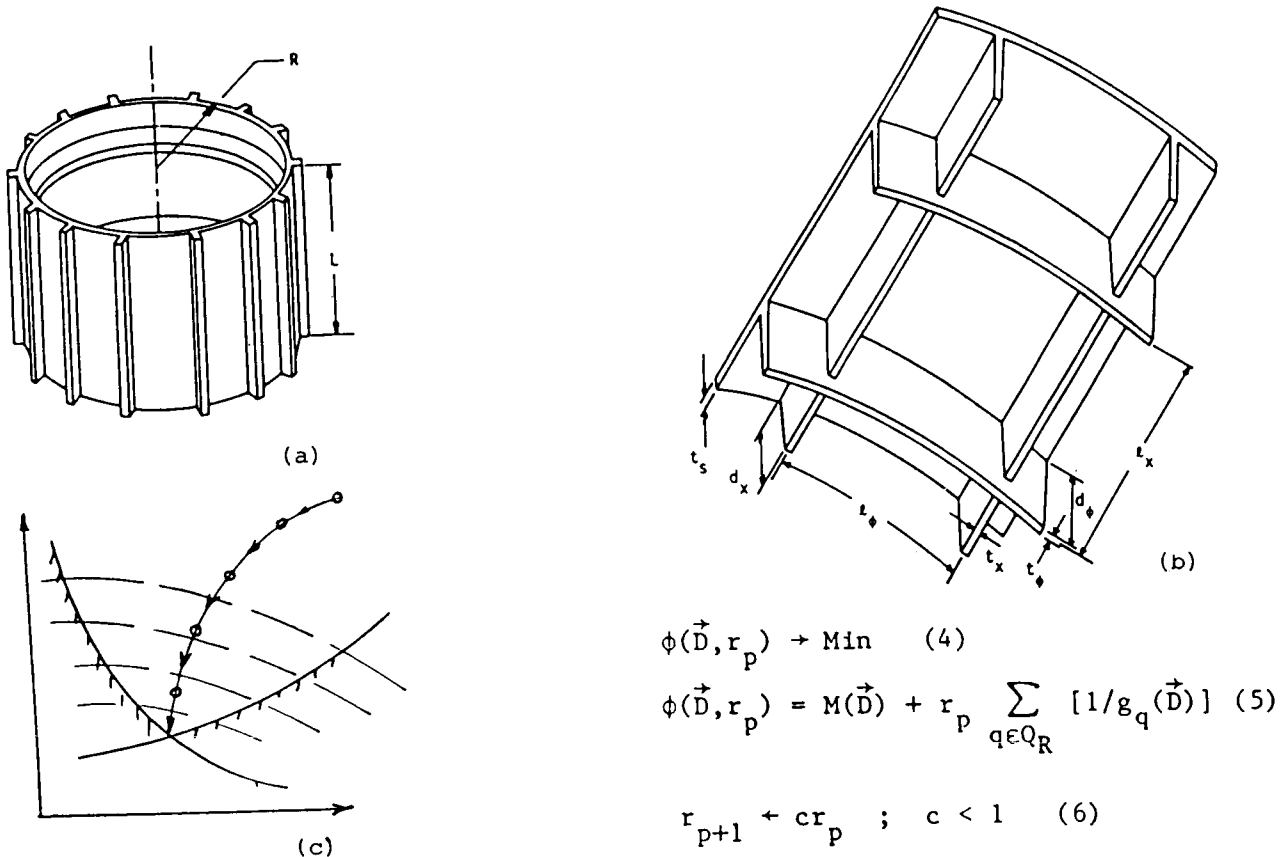

Figure 2

## DESIGN ORIENTED STRUCTURAL ANALYSIS

Interest in developing efficient system level structural synthesis capabilities based on finite element analysis models stimulated research on design oriented structural analysis (DOSA) during the 1965-1975 time period (e.g. see Ref. 6-14). This work was based on the idea that in a design context the objective of structural analysis should be to generate with minimum effort an estimate of the critical and potentially critical response quantities adequate to guide the design modification process. Developments in DOSA fall into three main categories: (1) behavior sensitivity analysis; (2) reduced basis methods for structural analysis; and (3) reorganization of finite element analysis methods to serve the special characteristics of the design optimization task (see Fig. 3). The basic goal of behavior sensitivity analysis is to obtain information about rates of change of response quantities with respect to changes in design variables. The key to accomplishing this involves implicit differentiation of the governing analysis equations with respect to the design variables, as illustrated by Eqs. 7 and 8 in Fig. 3 for the case of linear static structural analysis via the finite element (displacement) method. When sensitivity derivatives are needed for only a small subset of displacement components, it will be more efficient to employ adjoint methods (see Refs. 15-17). Reduced basis methods in static structural analysis are analogous to the common practice in dynamic analysis of using a reduced set of generalized coordinates and normal mode basis vectors. The basic idea, illustrated by Eqs. 9-12 in Fig. 3 is to use a relatively small number of well chosen basis vectors  $\vec{u}_n$  to drastically reduce the number of unknowns in the analysis from  $J$  to  $N$ . Finite element analysis can be better matched to the needs of the design optimization task. For example, the stiffness matrix  $K$  can be formed using precalculated and stored invariant parts  $K_0$  and  $K_i$  as illustrated by Eq. 12 in Fig. 3. This organization also makes the  $\partial K / \partial D_i$  (see Eq. 14), needed for behavior sensitivity analysis (see Eq. 8), already available in storage.

$$\text{Behavior Sensitivity} \quad K\vec{u} = P \quad (7)$$

(Static)

$$K \frac{\partial \vec{u}}{\partial D_i} = \frac{\partial \vec{P}}{\partial D_i} - \frac{\partial K}{\partial D_i} \vec{u} \quad (8)$$

$$\text{Reduced Basis} \quad \vec{u} \approx \vec{u}_A = \sum_{n=1}^N r_n \vec{u}_n = B\vec{r} \quad (9)$$

(Analysis)  $N \ll J = \text{DOF's}$

$$\pi_p \approx \tilde{\pi}_p = \frac{1}{2} \vec{u}_A^T K \vec{u}_A - \vec{u}_A^T \vec{P} \quad (10)$$

$$\pi_p = \frac{1}{2} \vec{r}^T B^T K B \vec{r} - \vec{r}^T B^T \vec{P} \quad (11)$$

$$\delta \tilde{\pi}_p = 0 \rightarrow B^T K B \vec{r} = B^T \vec{P} \quad (12)$$

$$\text{Finite Element} \quad K = K_0 + \sum_{i=1}^I D_i K_i \quad (13)$$

$$\text{Analysis Organization} \quad \frac{\partial K}{\partial D_i} = K_i \text{ (invariant)} \quad (14)$$

Figure 3

### ANALYSIS MODEL - DESIGN MODEL

When dealing with large system level design optimization problems it is very important to distinguish between the analysis model and the design model. While Fig. 4 illustrates this idea in terms of a structural system, it should be apparent that analogous distinctions exist in other areas (e.g. aerodynamic design, thermal design, etc.). Generating a structural analysis model usually involves idealization and discretization. In the context of the finite element method, idealization refers to selecting the kinds of elements and discretization refers to deciding on the number and distribution of finite elements and displacement degrees of freedom (DOF's) (see Fig. 4a). Once these decisions have been made, the structural analysis problem has a definite mathematical form. Establishing the design model involves another important set of decisions, namely: (1) deciding on the kind, number, and distribution of design variables; (2) identifying the load conditions and constraints to be considered during the design optimization; and (3) selecting the objective function. This process may be viewed as somewhat analogous to making the judgements that lead to the analysis model. A schematic representation of three alternate skin design models is shown in Fig. 4b. Limitations on the number of independent design variables are often imposed by symmetry, fabrication, and cost control considerations. In many structural design optimization problems the number of finite elements needed in the analysis model (to adequately predict behavior) is much larger than the number of design variables required to describe the practical design problem of interest. In some problems involving substantial changes in configuration it may be necessary to dynamically update the analysis model as the design evolves (e.g. see Ref. 18). In any event, it should be recognized that analysis modeling and design modeling involve two distinct but interrelated sets of decisions.

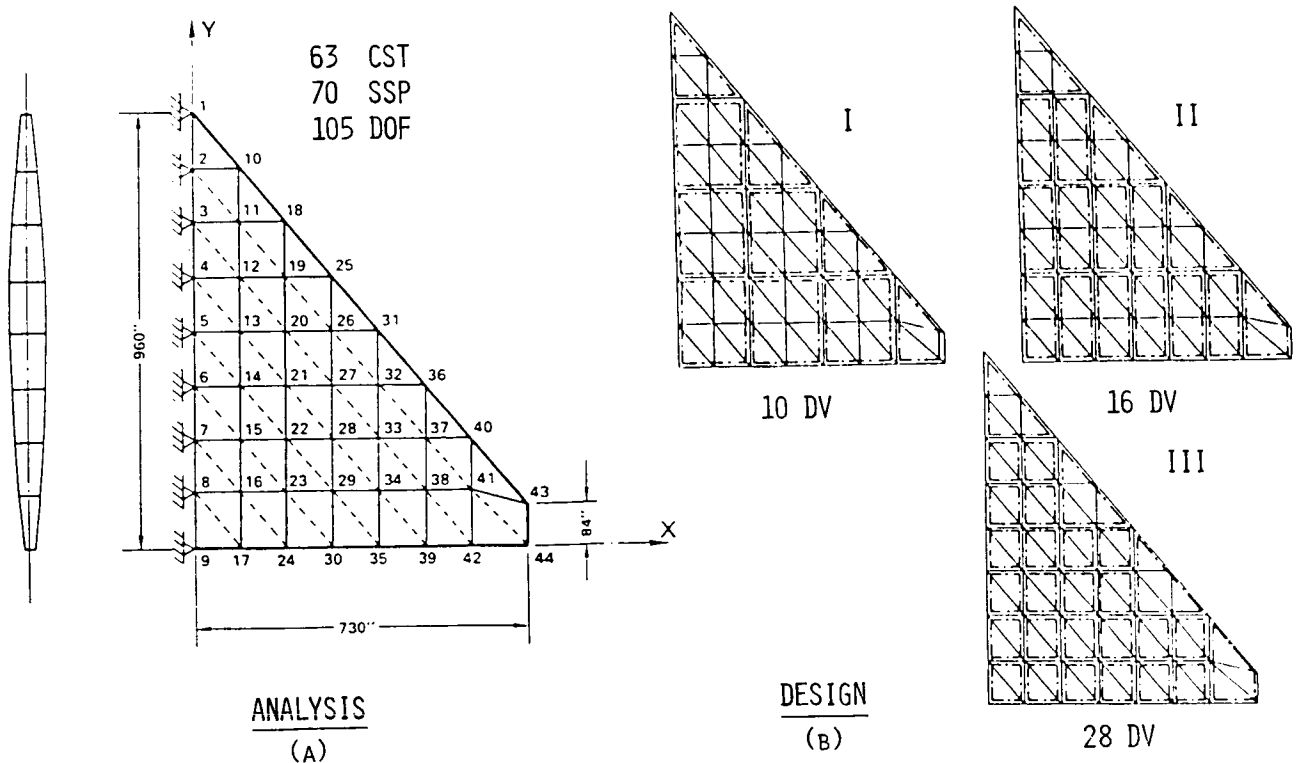

Figure 4

### KEY TO A TRACTABLE FORMULATION

Prior to 1970, the main obstacles to the development of large scale structural synthesis capabilities were associated with the fact that the general formulation (see Fig. 1, Eqs. 1 and 2) involved: (1) large numbers of design variables; (2) large numbers of inequality constraints; and (3) many behavior constraint functions that are computationally burdensome implicit functions of the design variables. During the 1970's these obstacles were overcome by replacing the initial problem statement with a sequence of relatively small, algebraically explicit, approximate problems that preserve the essential features of the original design optimization task (e.g. see Refs. 19 - 25). As indicated schematically in Fig. 5 this was accomplished through the coordinated use of approximation concepts such as: (1) reducing the number of independent design variables by linking and/or basis reduction; (2) reducing the number of constraints considered at each stage by temporary deletion of inactive or redundant constraints; and (3) constructing high quality explicit approximations for retained constraint functions (via the use of Taylor series expansions in terms of insightfully selected intermediate variables).

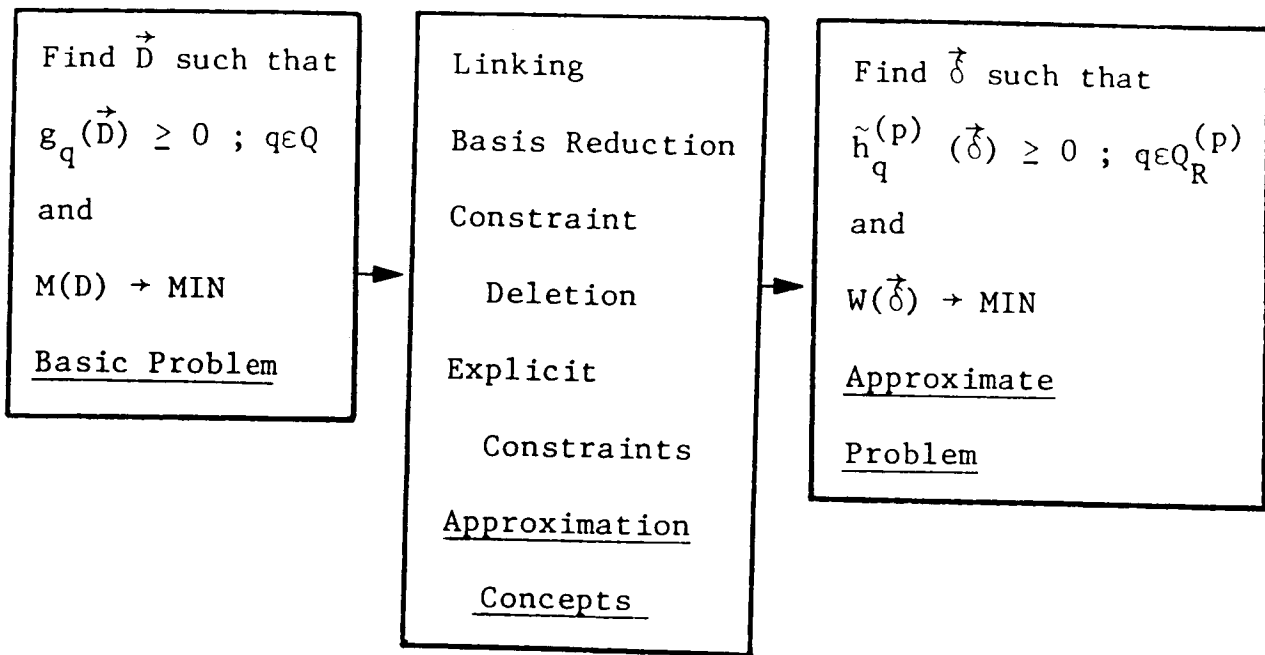

Figure 5

## APPROXIMATION CONCEPTS

In its simplest form, design variable linking fixes the relative sizes of some preselected group of finite elements. The reduced basis concept in design space further reduces the number of independent design variables by expressing the vector of  $I$  design variables  $\vec{D}$  as a linear combination of  $B$  prelinked basis vectors  $\vec{T}_b$ , where  $B \ll I$  (see Eq. 15, Fig. 6). Constraint deletion techniques such as regionalization and truncation represent computer implementation of conventional design practice. Regionalization is a scheme in which, for a specified region (e.g., all those elements linked to a particular design variable  $\delta_b$ ), only one constraint (the most critical) is retained for each loading condition. The truncation idea simply involves temporary deletion of constraints for which the response ratio  $R_q(\vec{D})$  (see Eq. 16, Fig. 6) is so low that the corresponding constraint will be inactive. In Eq. 16, Fig. 6) only those behavior constraints with response ratios greater than  $c$  are retained in the reduced set of constraints denoted by  $q \in Q_R^{(p)}$ . Also, in the case of linear constraints it is often possible to identify strictly critical constraints and they can be permanently deleted. When seeking high quality explicit approximations it is important to appreciate the flexibility offered by Taylor series expansions in terms of insightfully selected intermediate variables  $[x_b = f_b(\delta_b)]$ . Equation 17, Fig. 6 shows a general second-order Taylor series expansion for the constraint  $g_q$  in terms of intermediate design variables  $\vec{X}$ . This expression can be specialized and in the context of structural systems, first-order, second-order diagonal (separable), and full second-order approximations have been used. The use of reciprocal design variables has been notably successful in generating high quality explicit approximations for displacement constraints. Finally, it should be noted that in some instances it may be preferable to generate Taylor series expansions for response quantities while preserving the explicit nonlinearity inherent to the constraint function when it is expressed in terms of response quantities.

### Linking and Basic Reduction

$$\vec{D} = [L][R]\vec{\delta} = [T]\vec{\delta} = \sum_{b=1}^B \vec{T}_b \delta_b \quad (15)$$

### Constraint Deletion

$$g_q(\vec{D}) = 1 - R_q(\vec{D}) \geq 0 \quad ; \quad R_q(\vec{D}) = \frac{f_q(\vec{D})}{f_{qa}} \geq c \quad ; \quad q \in Q_R^{(p)} \quad (16)$$

### Explicit Constraints

$$g_q(\vec{X}) \approx \tilde{g}_q(\vec{X}) = g_q(\vec{X}^{(p)}) + (\vec{X} - \vec{X}^{(p)})^T \nabla g_q(\vec{X}^{(p)}) + \frac{1}{2} (\vec{X} - \vec{X}^{(p)})^T \left[ \frac{\partial^2 g_q}{\partial x_b \partial x_c}(\vec{X}^{(p)}) \right] (\vec{X} - \vec{X}^{(p)}) \quad (17)$$

Figure 6

### APPROXIMATION CONCEPTS BLOCK DIAGRAM

The approximation concepts approach to design optimization is shown in Fig. 7. This basic approach has been and continues to be used in developing modern structural design optimization capabilities; however it is potentially applicable to a much wider range of engineering design optimization problems. The approach outlined in Fig. 7 is modular and it combines the previously discussed approximation concepts and existing nonlinear programming algorithms. The "preprocessor" computes and stores all necessary information that is independent of the design variable values. A typical stage in the iterative design process begins with the control block supplying a "trial design" to the "approximate problem generator" (APG). Upon leaving the APG block, the current approximate problem statement is passed through "design process control" and handed off to the "optimization algorithm" block, along with a set of trial values for the design variables. This approximate problem is explicit and relatively small, therefore it can be solved using well-established algorithms. Furthermore, the approximate problem often has a special algebraic structure (e.g. convex, separable, quadratic, linear, etc.) which facilitates efficient solution via the use of special purpose techniques such as dual method algorithms (e.g. see Refs. 26-30). Once the "optimization algorithm" block has generated an improved design, it is passed back to the "design process control" block where it becomes the trial design for the next stage of the iterative design process outlined in Fig. 7. The multistage process is usually terminated by a diminishing returns criterion with respect to further improvement in the objective function. For a significant class of minimum weight structural sizing problems, it has been shown that practical convergence can be achieved using only 5 to 10 full finite element analyses.

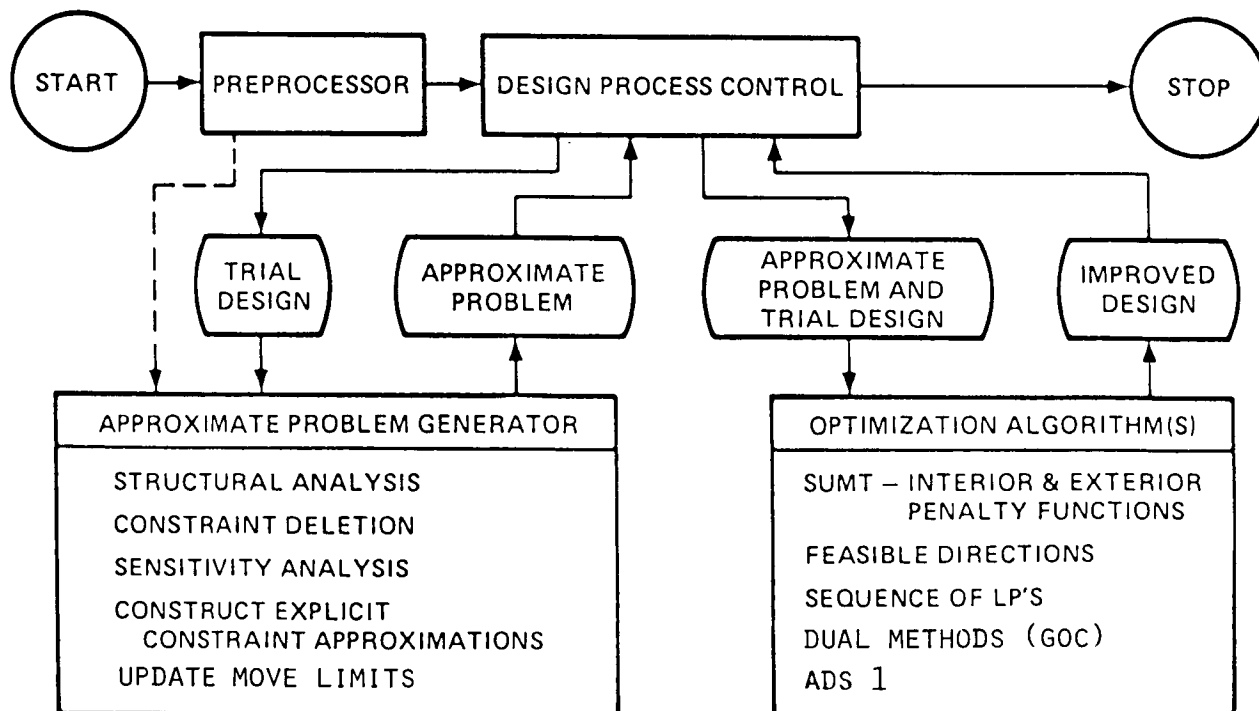

Figure 7



### SENSITIVITY ANALYSIS ANALOGY

While the use of behavior sensitivity analysis has become common practice during the past decade, the importance of optimum design sensitivity analysis has only recently been recognized by the structural optimization community (see Ref. 31 and subsequent work Refs. 32-35). Figure 8 outlines a useful analogy. In the analysis context, rates of change for behavior response quantities (e.g., displacements, stresses, natural frequencies, normal modes, etc.) with respect to design variables are obtained via implicit differentiation of the pertinent analysis equations (see Eq. 18, Fig. 8). In the optimum design context, rates of change for optimum design variable values (primal and dual) with respect to problem parameters (e.g., allowable displacement, allowable stress, applied load, etc.) are obtained via implicit differentiation of the necessary conditions characterizing the base optimum design (see Eq. 19, Fig. 8). Behavior sensitivity derivatives represent valuable quantitative information that can be used to: (1) help guide redesign via man-machine interaction; (2) construct explicit approximations for response quantities in terms of design variables (n.b.  $\alpha_b = 1/\delta_b$ ). These explicit approximations can often be used to bypass the actual analyses for alternative designs in the neighborhood of the base design. Optimum design sensitivity derivatives represent valuable quantitative information that can be used to: (1) help guide higher level trade-off studies via man-machine interaction; (2) construct explicit approximations for optimum design variable values in terms of problem parameters ( $p_k$ ). These explicit approximations can be used to bypass the actual optimization for modest changes in the problem parameters (assuming no shift in critical constraint set  $Q_{cr}$ , see Eq. 19, Fig. 8). The quality of the explicit approximations generated by behavior sensitivity/optimum design sensitivity analysis can often be improved by thoughtful selection of intermediate design variables/problem parameters. Also, optimum design sensitivity is important in the development of multi-level methods (see Ref. 36).

Behavior Response Sensitivity	Optimum Design Sensitivity
$\frac{\partial \vec{u}}{\partial \alpha_b}$ rates of change of response quantities w.r.t. design variables	$\frac{\partial \alpha^*}{\partial p_k}, \frac{\partial \lambda^*}{\partial p_k}$ rates of change of optimum primal and dual variables w.r.t. problem parameters
Implicit differentiation of pertinent analysis Eqs.	Implicit differentiation of necessary conditions at optimum
$\frac{\partial}{\partial \alpha_b} \left\{ \begin{array}{l} K \vec{u} = \vec{P} \\ \text{or} \\ K \vec{v} = \lambda M \vec{v} \\ \text{etc} \end{array} \right\} \quad (18)$	$\frac{\partial}{\partial p_k} \left\{ \begin{array}{l} \frac{\partial M}{\partial \alpha_b} - \sum_{q \in Q_{cr}} \lambda_q \frac{\partial g_q}{\partial \lambda_b} = 0; b \in \tilde{B} \\ g_q = 0; q \in Q_{cr} \end{array} \right\} \quad (19)$
man-machine interaction select intermediate DV's explicit approximations bypass analysis	trade-off studies select intermediate PP's explicit approximations bypass optimization

Figure 8

## AIRFOIL OPTIMIZATION

Many of the ideas that have played a key role in advancing the state of the art in structural synthesis are potentially transferable to design optimization tasks in other discipline areas. For example, in Refs. 37 and 38 numerical airfoil optimization is carried out using reduced basis concepts and Taylor series approximations. Various airfoil optimization tasks can be formulated as nonlinear programming problems. For instance the objective may be to minimize the drag coefficient  $C_D$  or maximize the lift coefficient  $C_L$ . Typically the constraints may include limits on lift, drag, pitching moment, thickness, and camber. The airfoil shape is defined as a linear combination of basis vectors  $\vec{Y}(1), \vec{Y}(2), \dots, \vec{Y}(n)$ , some or all of which may represent other airfoils (see Fig. 9a and Eq. 20). The scalars  $a_1, a_2, \dots, a_n$  in Eq. 20 can be thought of as participation coefficients and they are taken to be components of the vector of design variables  $\vec{X}$  (see Eq. 21). This reduced basis approach, first used for airfoil optimization in 1976 (see Ref. 39), provides good airfoil definition without having to use large numbers of design variables to define the airfoil thickness distribution. In Refs. 37 and 38 an innovative approximation concepts approach is used to reduce the number of aerodynamic analyses needed for design optimization by a factor of 2 or more. The basic idea used is to gradually develop second-order Taylor series approximations (see Eq. 22) for both the objective function  $F(\vec{X})$  and the constraint functions  $G_j(\vec{X})$  by using existing data or data generated earlier in the design optimization process. Each approximation generated for the  $F(\vec{X})$  (and the  $G_j(\vec{X})$ ) is used to improve the design (see Fig. 9b). This is followed by a full aerodynamic analysis which adds a new data point to the currently available set of data points. Examples reported in Refs. 37 and 38, as well as recent results (Ref. 40) using more realistic aerodynamics and spline function representation of airfoil shape, illustrate that approximation concepts can be successfully adapted to airfoil optimization.

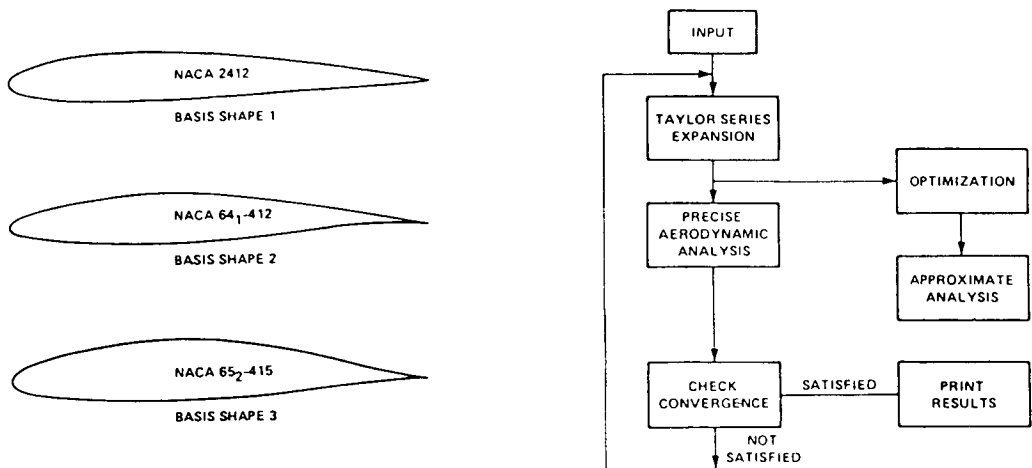

(a) Basis Shapes

$$\vec{Y} = a_1 \vec{Y}(1) + a_2 \vec{Y}(2) \dots a_n \vec{Y}(n) \quad (20)$$

$$\vec{X}^T = [a_1, a_2, \dots, a_n] \quad (21)$$

(b) Approximate Analysis

$$F(\vec{x}) = F^0 + \Delta \vec{X}^T \nabla F + \frac{1}{2} \Delta \vec{X}^T [H] \Delta \vec{X} \quad (22)$$

Figure 9

## THERMAL OPTIMIZATION

Thermal analysis and design is another area in which structural synthesis has served as a catalyst. For example in Refs. 41 and 42 techniques for computing the sensitivity of temperatures (steady state and transient) with respect to design variables that define a thermal protection system (and associated structure) have been developed and assessed. Also, in Ref. 43, explicit thermal response approximations based on first-order Taylor series expansions as well as constraint deletion techniques are successfully applied to some component level thermostructural design optimization problems (e.g. the thermostructural panel shown in Fig. 10a). The constraints for this problem are time parametric since the thermal behavior is transient (see Eq. 23). Instead of replacing the time parametric constraint (Eq. 23) with a large number of regular constraints representing the response at closely spaced time points  $t_j$  (Eq. 24), the response is monitored only at the most critical points (see Fig. 10b, points A, B, C, and Eq. 25). As the design changes during optimization the critical time points drift; however, it is shown in Ref. 43 that drift does not affect the first derivatives of the critical constraints (Eq. 25) with respect to design variables. During each stage in the approximation concepts approach employed in Ref. 43, the critical time points are frozen and Taylor series constraint approximations are generated only for that reduced set of constraints. The critical time points and the constraint approximations are updated periodically. It is reported in Ref. 43 that the combined use of these two approximation concepts produced an order of magnitude reduction in computational time required for convergence of the design optimization process. Finally, it should be noted that the reduced-basis method is also being applied to transient thermal analysis problems (see Ref. 44).

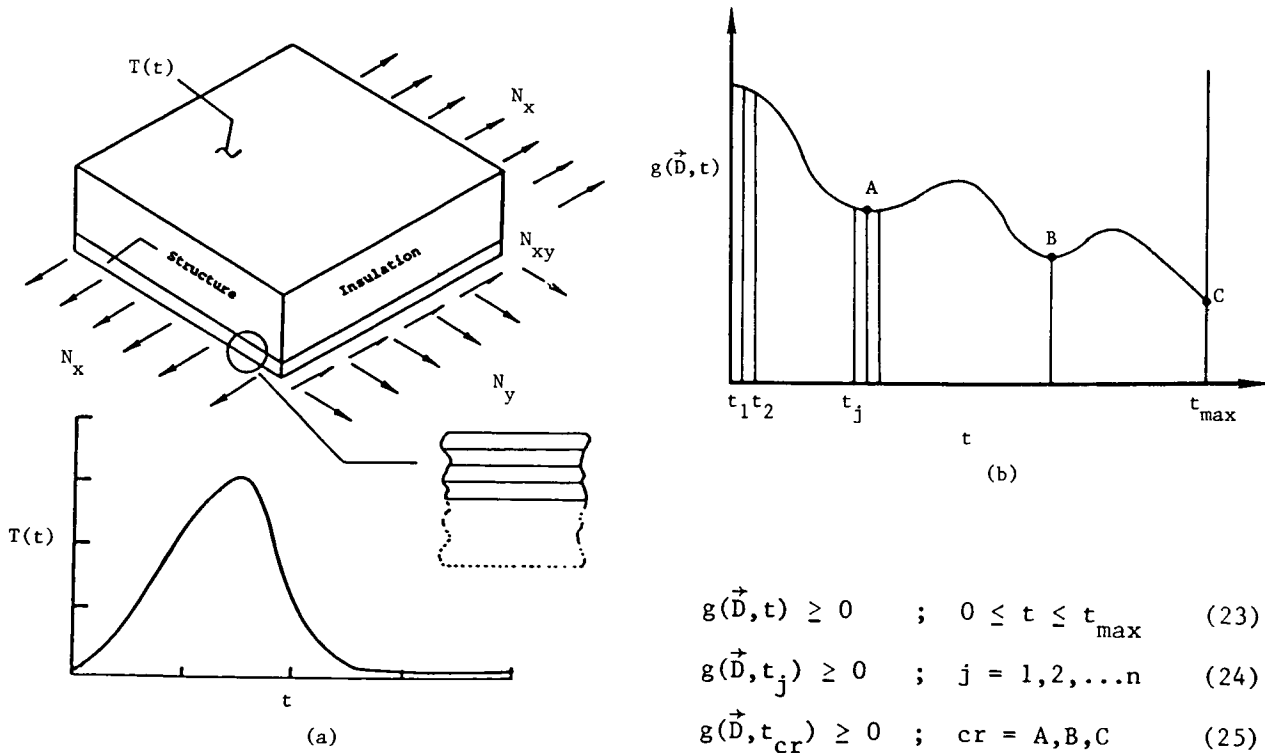

Figure 10

## OPTIMIZATION OF COMPRESSOR VANE SETTINGS

Gas turbine engines for jet aircraft must maintain high performance over a wide range of flight conditions; therefore variable-geometry configurations and bleed systems are built into components such as the fan and the compressor. During development many compressors are built with all vane rows variable, even though only a few rows may be left variable in the final design configuration. Primary compressor performance goals ( $M(\vec{D})$ ) include: maximum efficiency, maximum stall margin, maximum flow range, and maximum pressure ratio. Furthermore, there will always be constraints  $g_q(\vec{D}) \geq 0$ . For instance one might want to maximize efficiency while maintaining a minimum acceptable stall margin and also satisfying stress limitations. In Refs. 45-47 a sequence of approximate problems approach has been applied to the optimization of compressor vane settings. The block diagram shown in Fig. 11a (taken from Ref. 48) outlines the general approach. The basic idea is to gradually refine the approximations generated as more experimental data is accumulated. A particularly interesting part of the work reported in Ref. 45 involved optimization of a three-stage compressor with four rows of variable vanes. Optimization of compressor efficiency was carried out experimentally by both the traditional approach (sequentially opening and closing each vane row) and the sequence of approximate optimization problems approach. Vane settings were optimized for 8 different operating speeds (see Fig. 11b) and in each case the improvement in compressor efficiency achieved via the sequence of approximate optimization problems approach exceeds that obtained by the traditional approach. Furthermore, 40% fewer test points were required to obtain these superior results. The results reported in Ref. 45 support the contention that the approximations concepts approach to design optimization can be used to find better designs at significantly lower cost, even when the objective and constraint functions must be evaluated experimentally.

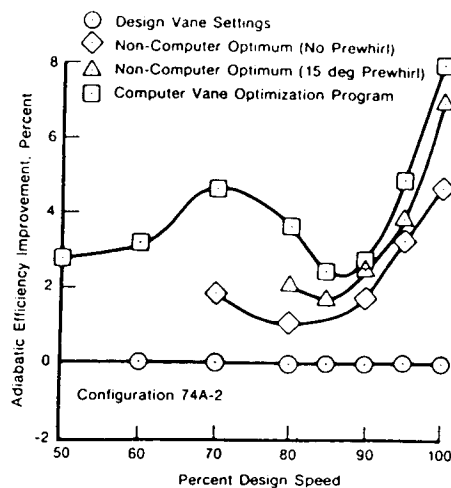
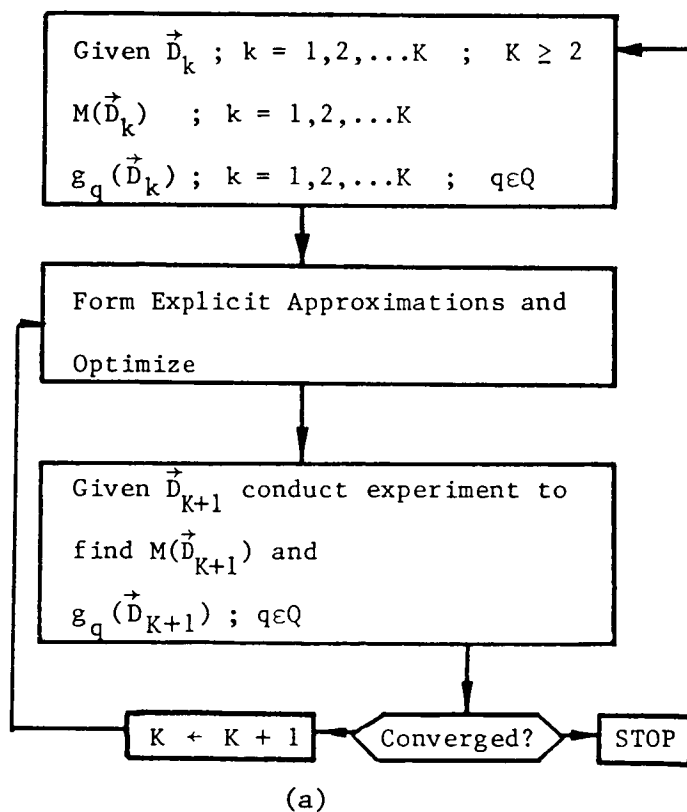

Figure 11

### MULTILEVEL METHODS AND DECOMPOSITION

The basic objective of multilevel methods is to break down a large unmanageable design optimization problem into a hierarchy of interconnected smaller problems that are tractable. When a large design optimization problem is naturally explicit (e.g. see Ref. 49) or when it can be replaced by a sequence of explicit approximations it may be possible to apply formal decomposition algorithms drawn from the mathematical programming literature. However the current limitations of formal decomposition algorithms are such that interest has been stimulated in the generation of heuristic decomposition techniques (e.g. see Refs. 50-54). In the structural synthesis context multilevel methods have been of continuing interest since the early 1970's (e.g. see Refs. 50 and 51). Almost all of the multilevel work in structural synthesis has focused on two-level systems such as that depicted schematically in Fig. 12. In Refs. 52 and 53 the multilevel method was improved by using: (1) a nonlinear programming formulation at both the component and the system level; (2) approximation concepts (linking, constraint deletion, and explicit constraint approximations) to facilitate efficient solution of the system level problems; (3) change in stiffness as the component level objective function to be minimized. Recently a general method for breaking large multidisciplinary problems down into several levels of subproblems was proposed (Ref.36). This general method was subsequently implemented for two-level structural optimization and successfully applied to a portal frame type structure (see Ref. 54). A key feature of this work is that it makes use of optimum design sensitivity analysis to convey to the system level coupling information about how the cumulative measure of component constraint violation (for each component) will react to changes in the system level design variables. Multilevel methods and formal decomposition are areas of continuing research activity that are likely to have significant influence on the development of multidisciplinary design optimization.

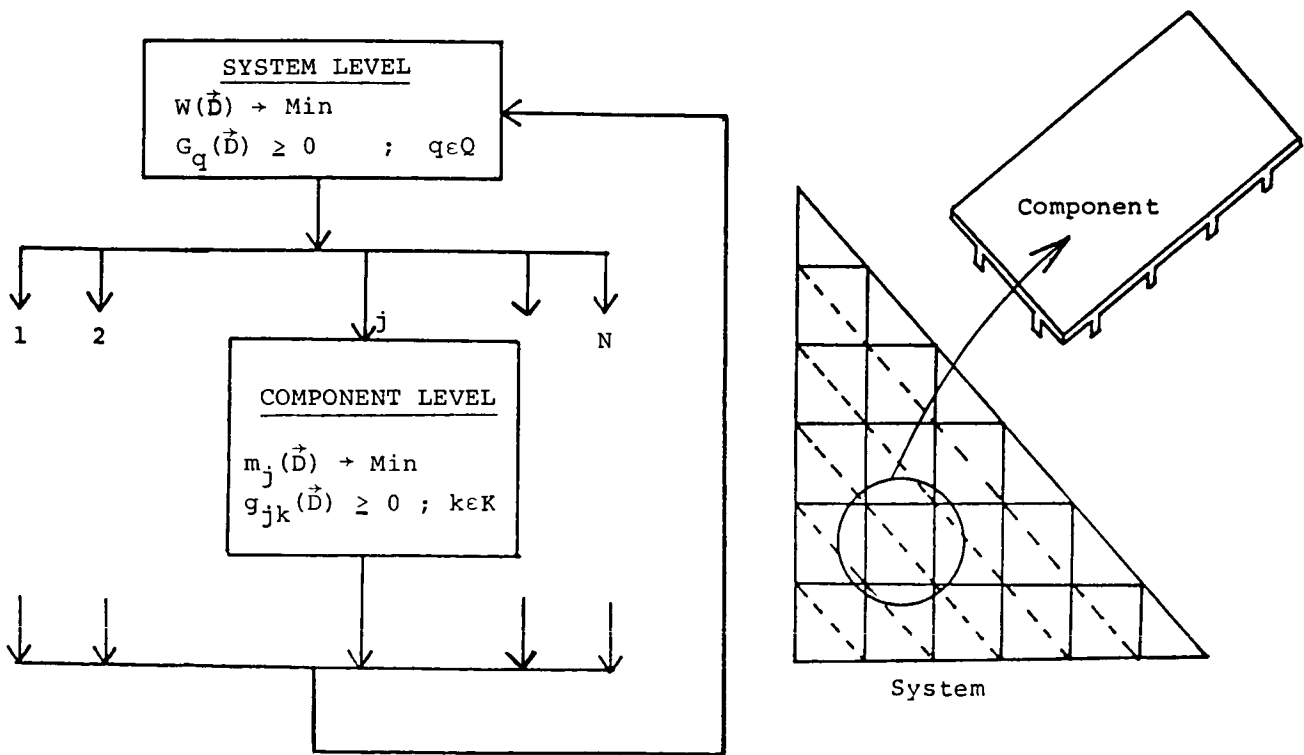

Figure 12

## SUMMARY

More than twenty five years have elapsed since it was recognized that a rather general class of structural design optimization tasks could be properly posed as an inequality constrained minimization problem. Figure 13 summarized several ideas that have played a key role in advancing the state of the art in structural synthesis. As indicated by the airfoil, thermal, and compressor vane examples some of these ideas are already being transferred or extended to other discipline areas. It is suggested that, independent of primary discipline area, it will be useful to think about: (1) posing design problems in terms of an objective function and inequality constraints; (2) generating design oriented approximate analysis methods (giving special attention to behavior sensitivity analysis); (3) distinguishing between decisions that lead to an analysis model and those that lead to a design model; (4) finding ways to generate a sequence of approximate design optimization problems that capture the essential characteristics of the primary problem, while still having an explicit algebraic form that is matched to one or more of the established optimization algorithms; (5) examining the potential of optimum design sensitivity analysis to facilitate quantitative trade-off studies as well as participation in multilevel design activities. An open-minded and imaginative quest for parallel opportunities in other disciplines offers significant potential for advancing the state of the art in multidisciplinary analysis and design. It should be kept in mind that multilevel methods are inherently well suited to a parallel mode of operation in computer terms or to a division of labor between task groups in organizational terms. Based on structural experience with multilevel methods the following general guidelines are suggested: (1) seek to weaken coupling between levels via basic organization, selection of intermediate level objective functions and the use of move limits; (2) whenever possible try to satisfy local constraints through local design variable changes; (3) for noncritical components seek a balanced design with uniform positive margins. Multilevel methods and decomposition can be expected to play a vital role in the development of multidisciplinary design optimization capabilities.

- NLP Formulation - Inequality Constraints
- DOSA : Behavior Sensitivity Analysis
  - Reduced Basis in Analysis
  - Organization of Analysis
- Analysis Model - Design Model
- Approximation Concepts
  - Linking and Basis Reduction
  - Constraint Deletion Techniques
  - Explicit Constraints (Taylor series)
- Match Optimization Algorithm  $\longleftrightarrow$  Approximate Problem
- Optimum Design Sensitivity Analysis
- Multilevel Methods and Decomposition

Figure 13

#### REFERENCES

1. Schmit, L.A., "Structural Design by Systematic Synthesis," Proceedings, 2nd Conference on Electronic Computation, ASCE, New York, 1960, pp. 105-122.
2. Schmit, L.A. and Kicher, T.P., "Structural Synthesis of Symmetric Waffle Plate," NASA TN D-1691, Dec. 1962.
3. Schmit, L.A., Kicher, T.P., and Morrow, W.W. "Structural Synthesis Capability for Integrally Stiffened Waffle Plates", AIAA Journal, Vol. 1, Dec. 1963, pp 2820-2836.
4. Kicher, T.P., "Structural Synthesis of Integrally Stiffened Cylinders," Journal of Spacecraft and Rockets, Vol. 5, Jan. 1968, pp. 62-67.
5. Morrow, W.M. and Schmit, L.A., "Structural Synthesis of a Stiffened Cylinder," NASA CR-1217, 1968.
6. Melosh, R.J. and Luik, R., "Approximate Multiple Configuration Analysis and Allocation for Least Weight Structural Design," AFFDL-TR-67-29, 1967.
7. Fox, R.L., "Constraint Surface Normals for Structural Synthesis Techniques," AIAA Journal, Vol. 3, Aug. 1965, pp. 1516-1517.
8. Fox, R.L. and Kapoor, M.P., "Rates of Change of Eigenvalues and Eigenvectors," AIAA Journal, Vol. 6, Dec. 1968, pp. 2426-2429.
9. Storaasli, O.O. and Sobieszczanski, J., "On the Accuracy of the Taylor Approximation for Structural Resizing," AIAA Journal, Vol. 12, Feb. 1974, pp. 231-233.
10. Fox, R. L. and Miura, H., "An Approximate Analysis Technique for Design Calculations," AIAA Journal, Vol. 9, Jan. 1971, pp. 177-179.
11. Noor, A.K. and Lowder, H.E., "Approximate Techniques of Structural Reanalysis," Computers and Structures, Vol. 4, Aug. 1974, pp. 801-812.
12. Noor, A.K. and Lowder, H.E., "Structural Reanalysis Via a Mixed Method," Computers and Structures, Vol. 5, April 1975, pp. 9-12.
13. Noor, A.K., "Multiple Configuration Analysis Via Mixed Method," Journal of the Structural Division, ASCE, Vol. 100, No. ST9, 1974, pp. 1991-1997.
14. Bhatia, K.G., "Rapid Iterative Reanalysis for Automated Design," NASA TN D-6534, 1971.
15. Fleury, C. and Sander, G., "Structural Optimization by Finite Element," University of Liege, Belgium, LTAS Report SA-58, Jan. 1978.
16. Arora, J.S. and Haug, E.J., "Methods of Design Sensitivity Analysis in Structural Optimization," AIAA Journal, Vol. 17, September 1979, pp. 970-974.
17. Vanderplaats, G.N., "Comment on Methods of Design Sensitivity Analysis in Structural Optimization," AIAA Journal, Vol. 18, No. 11, November 1980, pp. 1406-1407.
18. Bennett, J.A. and Botkin, M.E., "Shape Optimization of Two-Dimensional Structures with Geometric Problem Description and Adaptive Mesh Refinement," Proceedings, AIAA/ASME/ASCE/AHS 24th Structures, Structural Dynamics and Materials Conference, Lake Tahoe, Nevada, May 1983, pp. 422-431.
19. Schmit, L.A. and Farshi, B., "Some Approximation Concepts for Structural Synthesis," AIAA Journal, Vol. 12, May 1974, pp 692-699.
20. Haftka, R. T., "Automated Procedure for Design for Wing Structures to Satisfy Strength and Flutter Requirements," NASA TN D-7264, 1973.
21. Haftka, R.T. and Starnes, J.H., "Applications of a Quadratic Extended Interior Penalty Function for Structural Optimization," AIAA Journal, Vol. 14, June 1976, pp. 718-724.
22. Starnes, J.H. and Haftka, R.T., "Preliminary Design of Composite Wings for Buckling, Strength and Displacement Constraints," Proceedings, AIAA/ASME 19th Structures, Structural Dynamics and Materials Conference, Bethesda, MD, April 1978, pp. 1-13.
23. Schmit, L.A. and Miura, H., "Approximation Concepts for Efficient Structural Synthesis," NASA CR-2552, March 1976.
24. Schmit, L.A. and Miura, H., "A New Structural Analysis/Synthesis Capability - ACCESS 1", AIAA Journal, Vol. 14, May 1976, pp. 661-671.

25. Schmit, L.A. and Miura, H., "An Advanced Structural Analysis/Synthesis Capability - ACCESS 2," International Journal of Numerical Methods in Engineering, Vol. 12, Feb. 1978, pp. 353-377.
26. Fleury, C., "Structural Weight Optimization by Dual Methods of Convex Programming," International Journal of Numerical Methods in Engineering, Vol. 14, No. 12, 1979, pp. 1761-1783.
27. Schmit, L.A. and Fleury, C., "Structural Synthesis by Combining Approximation Concepts and Dual Methods," AIAA Journal, Vol. 18, Oct. 1980, pp. 1252-1260.
28. Schmit, L.A. and Fleury, C., "Discrete-Continuous Variable Structural Synthesis Using Dual Methods," AIAA Journal, Vol. 18, Dec. 1980, pp. 1515-1524.
29. Fleury, C. and Schmit, L.A., "Dual Methods and Approximation Concepts in Structural Synthesis," NASA CR-3226, Dec. 1980.
30. Fleury, C. and Braibant, V., "An Approximation Concepts Approach to Shape Optimal Design," Report SA-112, Aerospace Laboratory, University of Liege, Belgium, January 1984.
31. Sobieszczanski-Sobieski, J., "Optimum Design Sensitivity," Research in Progress Presentation, AIAA/ASME/ASCE/AHS 21st Structures, Structural Dynamics and Materials Conference, Seattle, Washington, May 1980.
32. Sobieszczanski-Sobieski, J., Barthelemy, J.-F., and Riley, K.M., "Sensitivity of Optimum Solutions to Problem Parameters," Proceedings of the AIAA/ASME/ASCE/AHS 22nd Structures, Structural Dynamics and Materials Conference, Atlanta, Georgia, April 1981, AIAA Paper No. 81-9548 (see also NASA TM-83134, May 1981 and AIAA Journal, Vol. 20, No. 9, September 1982, pp. 1291-1299).
33. Barthelemy, J.F. and Sobieszczanski-Sobieski, J., "Extrapolation of Optimum Design Based on Sensitivity Derivatives," AIAA Journal, Vol. 21, No. 5, May 1983, pp. 797-799.
34. Barthelemy, J.F. and Sobieszczanski-Sobieski, J., "Optimum Sensitivity Derivatives of Objective Functions in Nonlinear Programming," AIAA Journal, Vol. 21, No. 6, June 1983, pp. 913-915.
35. Schmit, L.A. and Chang, K.J., "Optimum Design Sensitivity Based on Approximation Concepts and Dual Methods," Int. J. for Numerical Methods in Engineering, Vol. 20, No. 1, January 1984, pp. 39-75.
36. Sobieszczanski-Sobieski, J., "A Linear Decomposition Method for Large Optimization Problems - Blueprint for Development," NASA TM-83248, February 1982.
37. Vanderplaats, G.N., "Efficient Algorithm for Numerical Airfoil Optimization," Journal of Aircraft, Vol. 16, No. 12, December 1979, pp. 842-847.
38. Vanderplaats, G. N., "Approximation Concepts for Numerical Airfoil Optimization," NASA TP-1370, March 1979.
39. Vanderplaats, G.N. and Hicks, R.M., "Numerical Airfoil Optimization Using Reduced Number of Design Coordinates," NASA TMX-73, 151, July 1976.
40. Misegades, K.P., "Airfoil Optimization," AIAA Paper No. 84-0053, AIAA 22nd Aerospace Sciences Meeting, Reno, Nevada, January 1984.
41. Haftka, R.T., "Techniques for Thermal Sensitivity Analysis," Int. J. for Numerical Methods in Engineering, Vol. 17, No. 1, January 1981, pp. 71-80.
42. Haftka, R.T. and Malkus, D.S., "Calculation of Sensitivity Derivatives in Thermal Problems by Finite Differences," Int. J. for Numerical Methods in Engineering, Vol. 17, No. 12, December 1981, pp. 1811 - 1821.
43. Haftka, R.T. and Shore, C.P., "Approximation Methods for Combined Thermal/Structural Design," NASA TP-1428, June 1979.
44. Shore, C.P., "Application of the Reduced Basis Method to Nonlinear Transient Thermal Analysis," Research in Structural and Solid Mechanics - 1982, NASA Conference Publication 2245, 1982, pp. 49-65.
45. Garberoglio, J.E., Song, J.O. and Boudreaux, W.L., "Optimization of Compressor Vane and Bleed Settings," ASME Paper No. 82-GT-81, Proceedings of 27th International Gas Turbine Conference and Exhibit, London, England, April 1982.



46. Garberoglio, J.E., Song, J.O. and Boudreaux, W.L., "Optimization of Compressor Vane and Bleed Settings," AFWAL - TR - 2046, June 1981.
47. Garberoglio, J.E., Song, J.O. and Boudreaux, W.L., "Optimization of Compressor Vane and Bleed Settings - Users Manual," Report FR-13996, Pratt & Whitney Aircraft Group, AFWAL contract no. F33615-79-C-2013, 1981.
48. Vanderplaats, G.N., "Numerical Optimization Techniques for Engineering Design," McGraw Hill Book Co., New York, 1984.
49. Woo, T.H. and Schmit, L.A., "Decomposition in Optimal Plastic Design of Structures," Int. J. of Solids and Structures, Vol. 17, No. 1, January 1981, pp. 39-56.
50. Giles, G.L., "Procedure for Automating Aircraft Wing Structural Design," Journal of the Structural Division, ASCE, Vol. 97, No. ST 1, January 1971, pp. 99-113.
51. Sobieszczanski, J. and Leondorf, D., "A Mixed Optimization Method for Automated Design of Fuselage Structures," Journal of Aircraft, Vol. 9, December 1972, pp. 805-822.
52. Schmit, L.A. and Ramanathan, R.K., "Multilevel Approach to Minimum Weight Design Including Buckling Constraints," AIAA Journal, Vol. 16, February 1978, pp. 97-104.
53. Schmit, L.A. and Mehrinfar, M., "Multilevel Optimum Design of Structures with Fiber-Composite Stiffened-Panel Components," AIAA Journal, Vol. 20, January, 1982, pp. 138-147.
54. Sobieszczanski-Sobieski, J., James, B., and Dovi, A., "Structural Optimization by Multilevel Decomposition," AIAA Paper No. 83-0832, Proceedings of the AIAA/ASME/ASCE/AHS 24th Structures, Structural Dynamics, and Materials Conference, Part I, Lake Tahoe, Nevada, May 1983, pp. 369-382.