

JASA-CP-2426-VOL-4
9880014764

NASA Conference Publication 2426

Space Station Human Factors Research Review

*Volume IV: Inhouse Advanced
Development and Research*

LIBRARY COPY

DEC 11 1985

LANGLEY RESEARCH CENTER
LIBRARY, NASA
HAMPTON, VIRGINIA

*Proceedings of a workshop held at
Ames Research Center
Moffett Field, California
December 3-6, 1985*

NASA

NASA Conference Publication 2426

Space Station Human Factors Research Review

*Volume IV: Inhouse Advanced
Development and Research*

*Edited by
Trieve Tanner
Yvonne A. Clearwater
and Marc M. Cohen
NASA Ames Research Center
Moffett Field, California*

Proceedings of a workshop held at
Ames Research Center
Moffett Field, California
December 3-6, 1985

NASA

National Aeronautics
and Space Administration

Scientific and Technical
Information Division

1988

Space Station Human Factors Research Review

PREFACE

This conference proceeding is a compilation of the papers presented at the Space Station Human Factors Research Review held at NASA Ames Research Center from December 3-6, 1985. These presentations represent the first year of research supported by the Space Station Advanced Development program as well as on-going related research supported by other NASA programs.

Each day of this research review was dedicated to a different focus or discipline. The foci represent the various areas of expertise in the Space Human Factors Office and the Aerospace Human Factors Research Division at Ames Research Center. In general, the structure of the conference was to proceed from the more general topics to the more specific issues during each day and throughout the week.

Vic Vykukal, a specialist in advanced space suit design, chaired the first day's session, *EVA Research and Development*. After Vykukal presented an introduction to EVA Research and Development at Ames, representatives of each of the three aerospace contractors participating in the EVA Systems Study presented their views on Implications for Man-System Design. The final presentation related experiences in the deep-sea diving industry that are relevant to EVA.

Yvonne Clearwater, an environmental psychologist who is pioneering the quantitative modeling of human spatial habitability, chaired the second day, *Space Station Habitability: Behavioral Research*. After Clearwater presented an introduction to the Space Station Habitability Research Program within the Space Human Factors Office, contractors and grantees made presentations on habitability, productivity, operational simulation and aesthetics for space station design guidelines. The session concluded with a panel discussion consisting of the principal speakers.

Marc Cohen, an architect in innovative Space Station design, chaired the third day, *Space Station Habitability and Function: Architectural Research*. After Cohen presented an introduction to Ames Research Center Space Station Architectural Research, each of the contractor or grantee architects presented reports on the progress of their work in architectural design research. The session concluded with a panel discussion consisting of the principal speakers.

Triev Tanner, Acting Assistant Chief for the Research for the Aerospace Human Factors Research Division, chaired the fourth day, *Inhouse Advanced Development and Research*. After Tanner gave a brief introduction, the members of the division's basic research discipline groups presented papers in their respective areas of expertise: Cognition and Perception, Workload and Performance, and Human/Machine Integration.

Each of these four sessions is published as a separate volume of NASA CP-2426, with each day corresponding to the sequentially numbered volume.

TABLE OF CONTENTS

	Page
PREFACE	iii
AGENDA	vii
EXECUTIVE SUMMARY	xi
SPACE STATION PROXIMITY OPERATIONS AND WINDOW DESIGN	1
Richard F. Haines	
FROM SPATIAL DISPLAYS TO SPATIAL INSTRUMENTS: PERCEPTUAL ISSUES IN THE DESIGN OF PERSPECTIVE DISPLAYS	19
Stephen R. Ellis	
IMAGE MANAGEMENT RESEARCH	23
Andrew B. Watson	
NASA-AMES WORKLOAD RESEARCH PROGRAM	29
Sandra Hart	
SPATIAL COGNITION	77
Mary Kister Kaiser and Roger Remington	
VIRTUAL INTERFACE ENVIRONMENT	85
Scott S. Fisher	
FAULT DIAGNOSIS IN ORBITAL REFUELING OPERATIONS	89
Guy A. Boy	
ERROR-TOLERANCE AND PROCEDURE AIDS	113
Everett Palmer	
CLOSING REMARKS	128
Trieve Tanner	

TUESDAY AFTERNOON

December 3, 1985

- 12:30 Welcome and Overview of Advanced Development and Research at Ames**
Tom Snyder, Director of Aerospace Systems, NASA Ames
David Nagel, Acting Chief, NASA Ames Aerospace Human Factors Research
Division
Trieve Tanner, Chief, NASA Ames Space Human Factors Office

EVA RESEARCH AND DEVELOPMENT

Chair: Vic Vykukal

- 1:10 Introduction to EVA Research and Development**
Vic Vykukal, NASA Ames Space Human Factors Office

EVA PHASE A STUDY IMPLICATIONS FOR MAN-SYSTEMS DESIGN

- 1:30 Boeing:**
Joseph Thompson
- 2:30 Grumman:**
Fred Abeles
- 3:30 Break**
- 3:40 McDonnell Douglas:**
Tom Wood
- 4:40 Diving Industry Approaches to Work Systems Development**
Michael Gernhardt, Ocean Systems Engineering
- 5:40 Closing Remarks: Vic Vykukal**

WEDNESDAY
December 4, 1985

SPACE STATION HABITABILITY: BEHAVIORAL RESEARCH

Chair: Yvonne A. Clearwater

- 8:30 Introduction to the Space Station Habitability Research Program**
Yvonne Clearwater, NASA Ames Space Human Factors Office
- 9:00 Human Performance and Productivity Study**
Wayne Gonzalez, Lockheed, Astronautics Division
- 9:30 Space Station Functional Relationship Activity Analysis**
Al Steinberg, McDonnell Douglas Astronautics Co.
- 10:30 Break**
- 10:45 Space Station Operational Simulation Computer Model**
Al Globus and Rick Jacoby, Informatics General Corporation
- 12:00 Lunch**
- 1:00 Quantitative Modelling of Human Spatial Habitability**
James Wise, University of Washington
- 2:00 Privacy and Interpersonal Distancing Study**
Albert Harrison, University of California at Davis
- 3:00 Break**
- 3:15 Space Station Interior Color Study**
Mary Edwards, San Francisco Academy of Art
- 4:15 Human Adaptation Studies: Analogous Environments**
Yvonne Clearwater, NASA/Ames, Space Human Factors Office
- 4:30 Panel Discussion: Research Implications for Space Station Design**
Gonzalez, Steinberg, Globus, Wise, Harrison, Edwards

THURSDAY
December 5, 1985

**SPACE STATION HABITABILITY AND FUNCTION: ARCHITECTURAL
RESEARCH**

Chair: Marc M. Cohen

- 8:30 Introduction: Ames Space Station Architectural Research**
Marc M. Cohen, Architect, NASA Ames Space Human Factors Office
- 9:30 Space Station Architectural Elements Model Study**
Tom Taylor and Associates (TAI), with Ethan Clifton, Eyoub Khan and John Spencer
- 10:30 Break**
- 10:40 Space Station Architectural Elements Model Study**
Michael Kalil Design Studio
- 11:40 General Discussion**
- 12:00 Lunch**
- 1:00 Space Station Group Activities Habitability Module Study**
David Nixon and Terry Glassman, Southern California Institute of Architecture
- 2:00 Full Scale Architectural Simulation Techniques for Space Station**
Colin Clipson, University of Michigan, Architectural Research Lab
- 3:00 Break**
- 3:10 Social Factors in Interior Furnishings**
Galen Cranz and Alice Eichold, U.C. Berkeley, College of Environmental Design
- 4:10 Panel Discussion: Research Implications for Space Station Design**
Cohen, Nixon, Taylor, Kalil, Clipson, Cranz

FRIDAY MORNING

December 6, 1985

INHOUSE ADVANCED DEVELOPMENT AND RESEARCH

Chair: Trieve A. Tanner

- 8:00 Cognition and Perception**
Andrew Watson, NASA Ames ASHFRD
- Space Station Proximity Operations and Windows**
Richard Haines, NASA Ames ASHFRD
- Prox-Ops Perspective Display: Spatial Displays – VERT**
Steve Ellis, NASA Ames ASHFRD
- Image Management**
Andrew Watson, NASA Ames ASHFRD
- 9:15 Workload and Performance**
Sandra Hart, NASA Ames ASHFRD
- Space Suit Workload Experiment**
RMS Workload Prediction/Assessment
Cursor Control in Zero-G (Flight Experiment)
- 10:30 Break**
- 10:40 Human/Machine Integration**
Everett Palmer, NASA Ames ASHFRD
- Spatial Cognition**
Mary Kaiser, NASA Ames ASHFRD
- Virtual Environment**
Scott Fisher, NASA Ames ASHFRD
- Fault Diagnostics in Orbital Refueling Operations**
Guy Boy, NASA Ames ASHFRD
- Error Tolerance/Procedure Aids**
Everett Palmer, NASA Ames ASHFRD
- 12:00 Closing Remarks**
Trieve A. Tanner
- 12:20 Tour of Mock-up Facility**

EXECUTIVE SUMMARY

Volume IV completes the review of our Space Station Human Factors Program. Volume I examined the EVA-oriented portion of the program. Volumes II and III dealt with the research that is associated with habitability – making the total habitable space on Space Station supportive of human well being and productivity.

The research that will be presented in this volume is more specifically associated with the human factors of the work station. Much of this work had its origin in addressing human factors issues in an aeronautical work station – the cockpit. Where we have seen analogs between the cockpit as a work station and the potential work stations on the Space Station, we have focused elements of our program on Space Station issues.

The work station that we will be simulating in our first mockup, discussed in Volume II, is a proximity-operations work station. Proximity operations will involve some of the more important activities of at least the initial Space Station, Shuttle docking, satellite servicing, and other initial work.

A proximity-operations work station can place great burdens on the crew operators if not properly designed. Yet proper design of the various interfaces between crew and machine can enhance productivity by avoiding the limitations and taking advantage of the capabilities of both the human and the machine. Some of the reports then will be focused on proximity operation issues; others will be focused on issues associated with other Space Station work stations. Two of the tasks that we are reporting today, workload and performance, and perspective displays (and all of the tasks reported in the other volumes) have been supported as part of the Space Station Advanced Development Program. The remainder of the tasks (and some of those reported in the other volumes) are part of the Office of Aeronautics and Space Technology's Research and Technology program.

The reports represent the Space-Station-oriented portions of the programs of three Working Groups within the Aerospace Human Factors Research Division: the first group is concerned with human factors issues associated with human perception and cognition; the second group with human workload and performance; and the third group with specific human/machine interaction issues. Each set will be introduced by the group leader.

Space Station Proximity Operations and Window Design

Richard F. Haines

Aerospace Human Factors Research Division
Ames Research Center - NASA
Moffett Field, Calif. 94035

March 24, 1986

ABSTRACT

On-orbit proximity operations (PROX-OPS) refers to all EVA within one km of the Space Station. Because of the potentially large variety of PROX-OPS, very careful planning for Space Station windows is called for and must consider a great many human factors. This paper reviews some of these human factors using as its outline a NASA Technical Memorandum in preparation by the author. The following topics are discussed: (1) basic window design philosophy and assumptions, (2) the concept of the local horizontal - local vertical on-orbit, (3) window linear dimensions, (4) selected anthropomorphic considerations, (5) displays and controls relative to windows, (6) full window assembly replacement, (7) Summary and Conclusions, and (8) References.

INTRODUCTION

Relatively little has been written on the important subject of Space Station windows. A NASA Technical Memorandum (TM) now in preparation (Haines, 1986) documents most of the prior technical references dealing with the optical, geometric, and structural properties of windows installed on prior US and Soviet spacecraft and will not be repeated here. Good window designs result from a deliberate and painstaking analysis of all of the tasks which the viewer must carry out through the window(s), the operational capabilities and limitations of the entire Space Station on-orbit, the perceptual and physiological capabilities and limitations of the viewer over time, and a host of other factors too complex to deal with here. As stated in NASA report JSC-19989 (1984; pg. 3) describing the so-called Reference Configuration for the Space Station, "One of the principal advantages of this configuration is the good viewing afforded to all payloads, both externally-mounted and internally mounted." Such viewing will require properly designed windows.

Figure 1 presents the Table of Contents for the forthcoming TM by the author with a mark at those subjects that are discussed (briefly) here.

Figure 1

Table of Contents of NASA TM Entitled
“Space Station Proximity Operations Windows: Human Factors Design Guidelines”
(Haines, 1986)

- 0.0 Introduction
 - 0.1 Justification for this Report
 - 0.2 Subjects Not Covered
 - 0.3 Window Design Assumptions
 - 0.4 Window Design Philosophy
 - 0.5 Proximity Operation Station

- 1.0 Solar Illumination Ambient Geometry and Cyclic Timing
 - 1.1 Basic Characteristics
 - 1.1.1 Radiation and Photometric Constants
 - 1.1.2 Angular Constants
 - 1.2 Temporal Characteristics
 - 1.2.1 Orbital Inclination Parameters
 - 1.2.2 Orbital Altitude Parameters
 - 1.3 Earthlight and Moonlight

- 2.0 Artificial Illumination Geometry
 - 2.1 Space Station Light Sources
 - 2.1.1 Exterior Mounted Floodlights and Spotlights
 - 2.1.2 Exterior Mounted Running Lights
 - 2.1.3 Interior Mounted Lights
 - 2.2 Shuttle (or Moving Target) Light Sources
 - 2.2.1 Exterior Mounted Floodlights and Spotlights
 - 2.2.2 Exterior Mounted Running Lights
 - 2.2.3 Interior Mounted Lights
 - 2.2.4 Payload Bay Floodlights

- 3.0 Human Observer Tasks and Related Window Design Requirements
 - 3.1 Selected “Return/Rendezvous” Maneuver Requirements
 - 3.1.1 Manned Active Approaches (\pm)
 - 3.1.1.1 Local Vertical Local Horizontal Radius Vector
 - 3.1.1.2 Local Vertical Local Horizontal Momentum Vector
 - 3.1.1.3 Local Vertical Local Horizontal Velocity Vector
 - 3.1.2 Unmanned Approach to Manned Space Station
 - 3.2 Special “Deployment/Separation” Maneuver Requirements
 - 3.3 Space Station Construction Activities
 - 3.4 Window Field of View-Related Human Factors Design Tradeoff Parameters
 - 3.4.1 Window (Linear) Dimensions
 - 3.4.2 Eye-Inner Pane (Set-back) Distance

Figure 1 – Continued

- 3.4.2.1 Anthropomorphic Considerations
- 3.4.2.2 Surface Contamination Considerations
- 3.4.3 Design Eye Point Lateral Offset from Window Centerline
- 3.4.4 Allowable Head/Eye Movements
 - 3.4.4.1 Radial (Set-back) Translation
 - 3.4.4.2 Vertical Translation
 - 3.4.4.3 Horizontal and Vertical Eyeball Rotation Limits
- 3.4.5 Gap Width Considerations
- 3.4.6 Multiple, Adjacent Windows
- 3.5 Distribution of Various Sensitivities in the Visual Field
- 3.6 Number of Viewers per Window
- 3.7 Number of Windows and Location Relative to Viewers
- 3.8 Prox-Ops Station Controls and Displays Relative to the Window(s)
- 4.0 Window Optical Requirements
 - 4.1 Transmissivity
 - 4.1.1 Absolute (Visible Spectrum Near IR-Near UV)
 - 4.1.1.1 Prior U.S. Spacecraft Specifications
 - 4.1.1.2 Selected Visual Functions Requiring Certain Wavelength Ranges(s)
 - 4.1.2 Spectral (Selected Wavelengths)
 - 4.1.2.1 Dichroic Filters for Heat Rejection/Control
 - 4.1.2.2 Monochromatic Filters for Contrast Optimization, Scientific Tasks
 - 4.1.3 Variability
 - 4.2 Electrically Conductive Optical Coatings
 - 4.3 Line of Sight Deviation (Prism Effect) and Light Scatter
 - 4.4 Line of Sight Displacement
 - 4.5 Magnification/Minification
 - 4.6 Astigmatism
 - 4.7 Surface Reflections and Haze
 - 4.7.1 From Exterior Light Sources
 - 4.7.2 From Interior Light Sources
 - 4.7.2.1 Moving (Illuminated) Surfaces/People
 - 4.7.2.2 Fixed Light Sources
 - 4.7.3 Multiple Reflections
 - 4.8 Sun Shades
- 5.0 Window-Maintenance and Protection
 - 5.1 Types of Degradation/Damage
 - 5.1.1 Surface Contamination (Cleanable)
 - 5.1.1.1 Exterior
 - 5.1.1.2 Interior
 - 5.1.1.2.1 Body/Skin Oils
 - 5.1.1.2.2 Breath Condensation
 - 5.1.2 Surface Contamination (Non-Cleanable)
 - 5.1.2.1 Exterior
 - 5.1.2.1.1 Rocket Plume Impingement (Solid, Liquid)
 - 5.1.2.1.2 Other Sources

Figure 1 -- Concluded

- 5.1.3 Permanent Surface Damage (Requiring Replacement)
 - 5.1.3.1 Micrometeorite Impact (Pitting)
- 5.1.4 External (Pressure Pane) Breakage
- 5.1.5 Puncture of All Window Panes (Pressure Loss)
- 5.1.6 Spectral Transmission Change (Radiation/Thermal)
- 5.1.7 Thermal Shock Breakage
- 5.1.8 Other Causes of Degradation
- 5.2 Candidate Methods of Maintenance
 - 5.2.1 Hand Cleaning
 - 5.2.2 Mechanical Polishing/Buffering
 - 5.2.3 Pane Replacement
 - 5.2.4 Full Window Assembly Replacement
 - 5.2.5 Replaceable Shields
- 5.3 Candidate Methods of Protection On-Orbit
 - 5.3.1 Shutters (Mechanically Actuated)
 - 5.3.2 Laminar Air Flow
 - 5.3.3 Permanent Temporary Frames
- 5.4 Crew Safety Threats Related to Prox-Ops Windows
 - 5.4.1 Catastrophic Failure
 - 5.4.2 Hazardous Failure
 - 5.4.3 Inconvenience Failure
- 6.0 References
- 7.0 Appendices
 - A. Mercury Capsule Windows and Related Details
 - B. Gemini Capsule Windows and Related Details
 - C. Apollo Command Module Windows and Related Details
 - D. Apollo Lunar Excursion Module Windows and Related Details
 - E. Skylab Windows and Related Details
 - F. Space Shuttle Vehicle Windows and Related Details
 - G. Soviet Vostok Capsule Windows and Related Details
 - H. Soviet Voskhod Capsule Windows and Related Details
 - I. Soviet Soyuz Capsule Windows and Related Details
 - J. Soviet Salyut Vehicle Windows and Related Details

I. BASIC WINDOW DESIGN PHILOSOPHY AND ASSUMPTIONS

The overall design philosophy for PROX-OPS windows include the following elements: (a) all windows shall support the greatest degree of external and internal situational awareness as possible, (b) all windows shall provide the greatest level of bodily protection possible from external radiation sources, and dangers resulting from changes in pressure, temperature, etc. (c) each window shall not allow visual degradation to occur due to veiling glare, flash blindness, or other unexpected luminous event during critical operational periods, and (d) each window shall provide as large a horizontal and vertical field of view (FOV) as possible.

Several basic assumptions have been made which take into account other engineering and mission requirements presented elsewhere (Donahoo and Anderson, 1985; McDonnell Douglas Astronautics, 1985; Oberg, 1982). They include: (a) for most PROX-OPS out-the-window activities there will be only one viewer per window, (b) a maximum window dimension of 20 inches will be allowed. Nevertheless, it is reasonable to assume that a 20" x 30" (50.8 x 76.2 cm) rectangular window will be permitted from a structural design standpoint, (c) round windows will not be used for PROX-OPS (primarily) because such a window shape eliminates any (target vehicle) roll cues or body orientation cues for the viewer, (d) window panes will be flat glass with an inert, dry gas filling inner cavities, (e) the thickness of window frames surrounding each window will be as small as possible to reduce visual occlusion of external objects, (f) all windows that are to be used for making color discriminations shall possess neutral spectral transmission so that perceived target object hues are not altered, and (g) each window shall be designed to accommodate a "design eye volume" (DEV) of approximately 0.6 cubic meter centered on the center of the window and set back 12" (30.5 cm) from the inner most pane.

II. THE LOCAL HORIZONTAL - LOCAL VERTICAL CONCEPT OF ON-ORBIT SPACE STATION STABILIZATION

Figure 2 illustrates the local horizontal-local vertical (LH-LV) concept of Space Station stabilization on-orbit and related nomenclature. The particular configuration of modules shown is not important. Throughout its orbital travel, the Space Station will pitch so as to maintain the center of the earth directly below it.

Figure 2

Local Horizontal - Local Vertical Space Station Stabilization

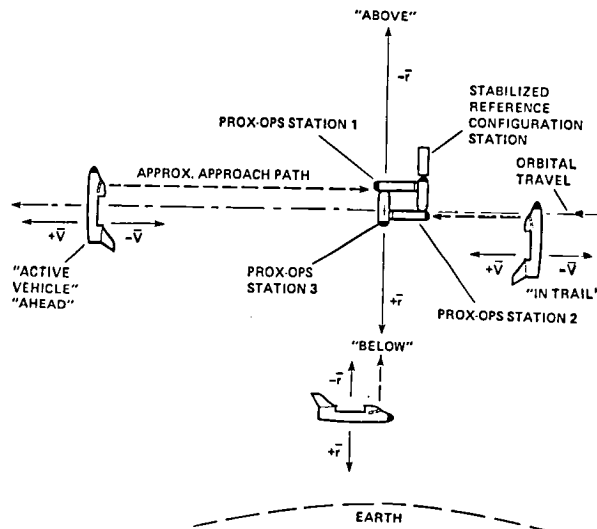

For certain approach trajectories (e.g., the minus R bar shown in Figure 3), the approaching target vehicle will not be visible from windows located in the end-cap of a module that are facing only in the minus V bar direction until the vehicle is very near the Space Station [typically under 100 ft (31 m)]. The windows must accommodate a large vertical FOV for this type of approach maneuver.

Figure 3

Nominal Minus R bar PROX-OPS Approach Trajectory

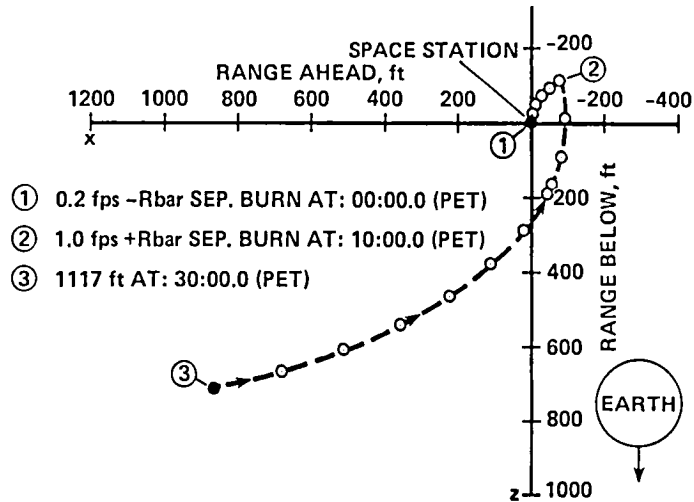

For other approach trajectories such as the plus V bar shown in Figure 4, the PROX-OPS windows must face in the direction of the velocity vector looking in the general direction of the rising sun. This will place the approaching target vehicle between the sun and the viewer and create many practical problems of target visibility along with optical design problems.

Figure 4

Nominal Plus V bar PROX-OPS Approach Trajectory

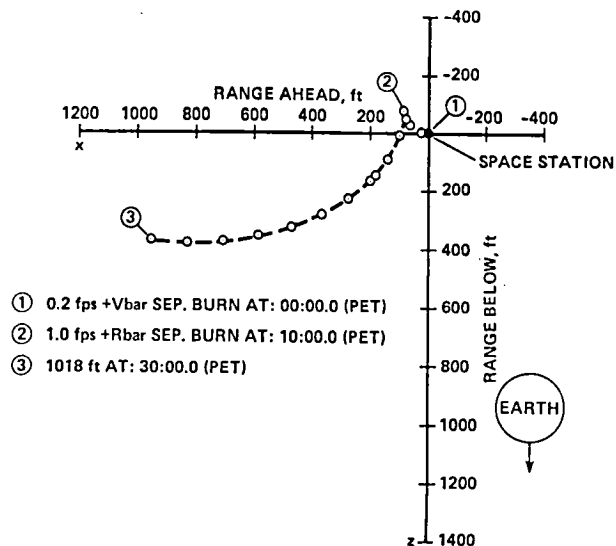

III. WINDOW LINEAR DIMENSIONS

The geometric variables which will determine the total available FOV of a window are shown in Figure 5. Figures 6 and 7 present the total FOV angle for a 9" (23 cm), 18" (46 cm), and 48" (122 cm) wide window as a function of the lateral offset distance ($X - X_1$ in Figure 5) for a 6" (5 cm) and 18" (46 cm) set-back distance. Clearly, both set-back distance and lateral offset play crucial roles in limiting the available FOV. When anthropomorphic considerations are taken into account, nominal window sizes may be determined (cf. Figure 8) which will then permit operational planners to know, in advance, whether an approaching vehicle following a particular trajectory will remain visible in a given window or not and at what point in its approach will it first appear. Such prior knowledge is very useful.

Figure 5

Geometric Variables Which Determine the Visual Angle for a Single Window

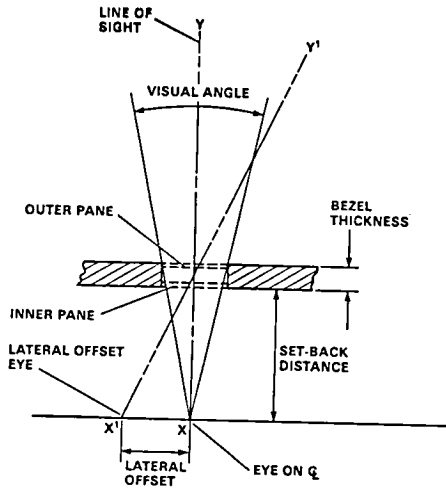

Figure 6

Visual Angle (deg.) for Three Window Sizes as a Function of Lateral Offset (in.) for a Six Inch Eye Set-Back Distance

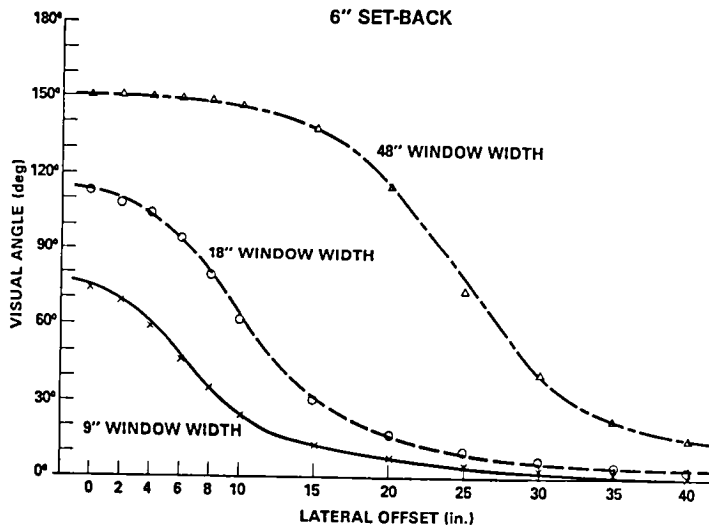

Figure 7

Visual Angle (deg.) for Three Window Sizes as a Function of Lateral Offset (in.) for an 18 Inch Eye Set-Back Distance

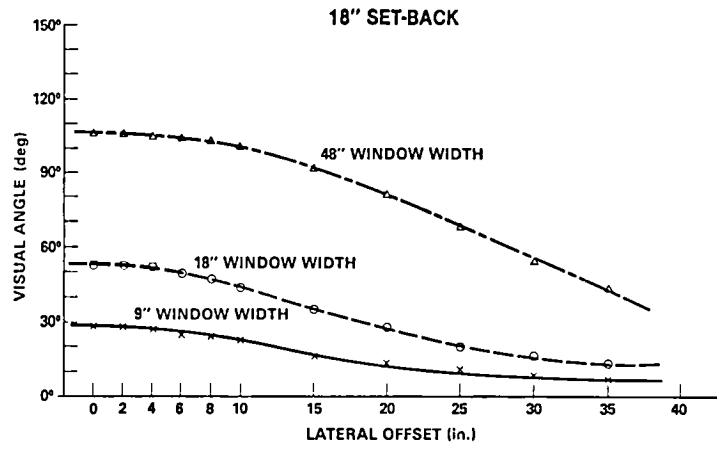
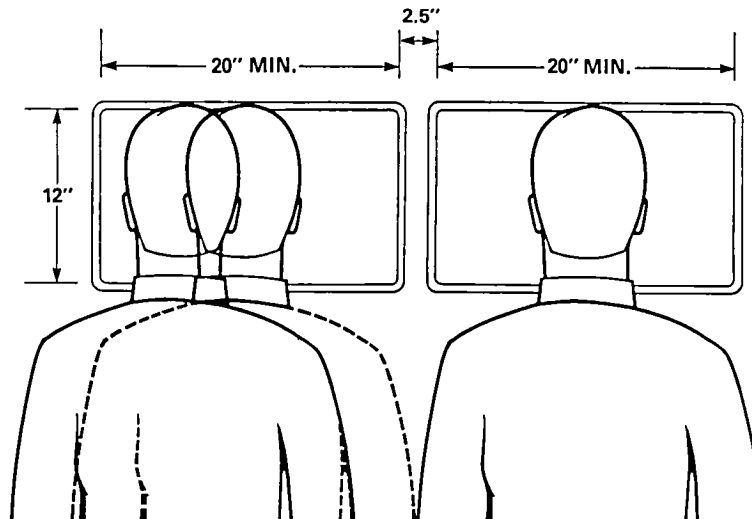

Figure 8

One Viewer Per Window Spacing Recommendation for a Small Set-back Distance



The last geometric variable considered here in regard to the maximum achievable FOV through a given window is that of bezel thickness, i.e., the thickness of the wall in which a window is installed. In Figure 5 this is shown (for convenience) as being equivalent to the separation distance between the innermost and outermost window panes. Calculations have been made of the visual angle across a 12" (30.5 cm) wide window with the eye on centerline but set-back various distances. Figure 9 presents the results of such calculations as a function of bezel thicknesses from zero to 5" (12.7 cm). It may be noted that visual angle through the window increases with decreasing set-back distance and also with decreasing bezel thickness in a regular fashion. Such data may be used to perform engineering trade-off studies of various geometric designs.

Figure 9

Visual Angle (deg) for Various Set-back Distances and Bezel Thicknesses for a 12" (30.5 cm) Wide Window

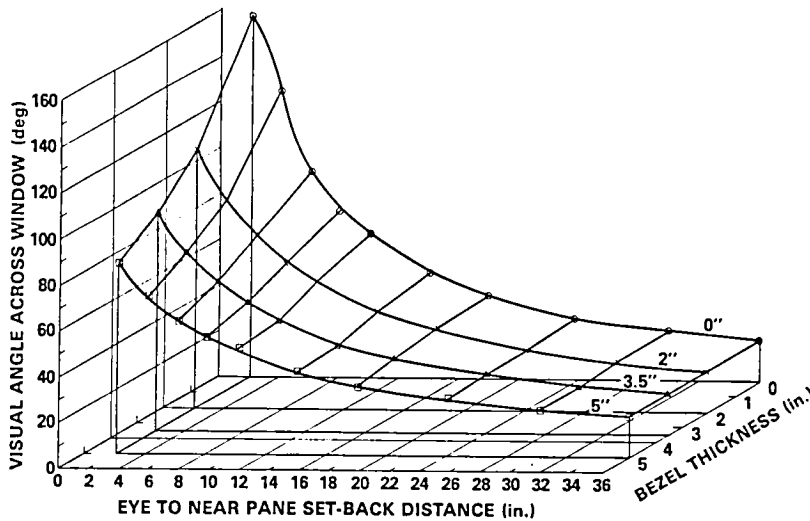

IV. SELECTED ANTHROPOMORPHIC CONSIDERATIONS

Among the many anthropomorphic considerations related to Space Station window design are those related to micro-gravity body posture (Griffin, 1978; Jackson et al., 1975). The basic situation is illustrated in Figure 10 for a set-back distance of 12" (30.5 cm) from the innermost pane. Because the head flexes forward, the average line of sight (LOS) is depressed by about 20 to 30 deg arc compared to its nominal direction in one g. The legs and arms also tend to bend somewhat as shown.

Figure 10

Approximate Neutral Body Position in Prolonged Weightlessness

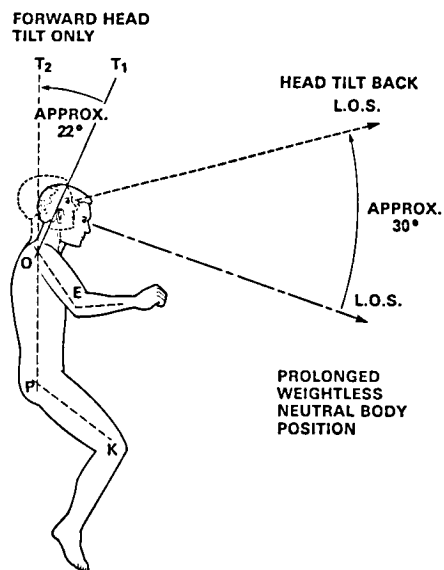

When the viewer must look through a Space Station window for prolonged periods of time using relatively small set-back distances and (hand, knee) body clearance (cf. Figure 11), the body axis angle T-O-P must approach 180 deg rather than flex forward to about 150 deg. This can result in neck tension, pain and fatigue. By increasing the eye set-back distance, the body can assume a more natural and comfortable posture as is shown in Figure 12.

Figure 11

Illustration Showing the Deviation from the Neutral Body Position Required to View Through a Window that is 12 Inches Away

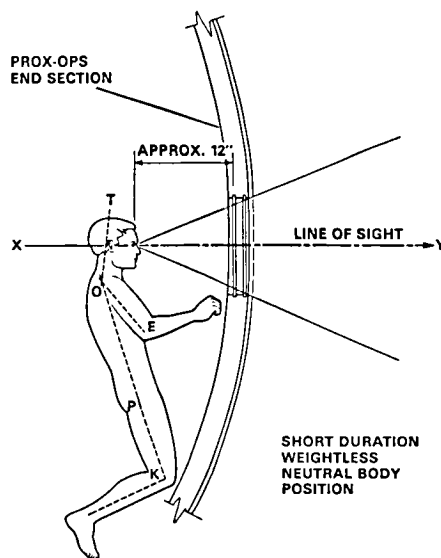
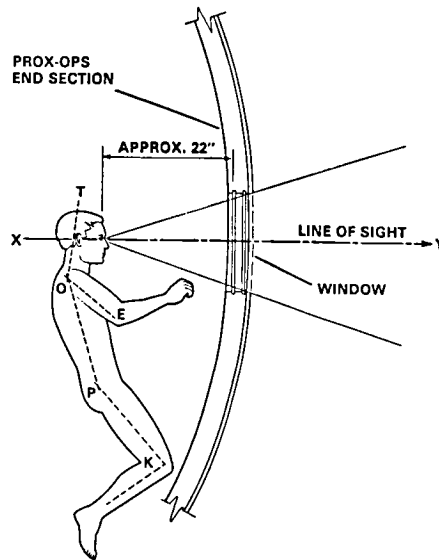

Figure 12

Illustration Showing the More Natural and Comfortable
Body Position Possible by Increasing the
Eye to Window Set-back Distance



V. DISPLAYS AND CONTROLS RELATIVE TO WINDOWS

The human factors specialist familiar with traditional aircraft cockpit layout and design should be consulted in regard to how best to locate informational displays and controls in a PROX-OPS station. A fundamental difference between the two design environments is the fact that, on-orbit, the design eye *point* turns into a design eye *volume*. Due to the fact that viewers in prolonged micro-gravity will not need to be as physically constrained as they are in the cockpit of an airplane, they will necessarily experience more (voluntary and involuntary) slow head translation per unit time. For most extra-vehicular observing tasks this should not prove to be a problem. For many interior observing tasks, such as monitoring a precision TV display during the final stages of berthing, head translation may lead to some serious perceptual and operational problems.

Another consideration with regard to the proper layout design of PROX-OPS displays and windows has to do with maintaining as much relevant display information as possible within the viewer's binocular visual field while he or she is viewing out a window. This concept is illustrated in Figure 13. A design eye volume of approximately 0.6 cubic meters is recommended for each window such that the viewer could move any place within this volume and be able to perceive the same quantity and quality of interior (panel) information. Such a design requirement will help the viewer maintain a high degree of situational awareness. Space does not permit a fuller treatment of this topic. The interested reader should consult Haines (1975) and its references for further information.

Figure 13

Proximity Operations Control Station Concept to Achieve Full Binocular Visual Sensitivity While Viewing Through a Given Window

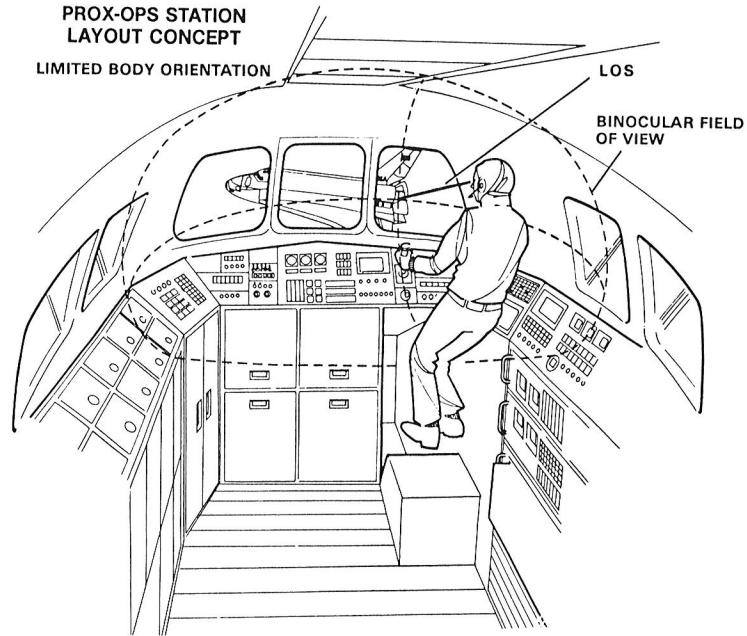

Locating PROX-OPS displays and controls must take into account the location, spacing, shape, number, and size of the windows present. A candidate window arrangement that is being evaluated at Ames in the Proximity Operations Simulator consists of five windows arranged in an inverted T. Figure 14 shows this arrangement.

Figure 14

Front View of a Scale Model Ellipsoidal End Cap Designed by Marc M. Cohen, AIA, Showing a Candidate "Inverted T" Arrangement of Windows.

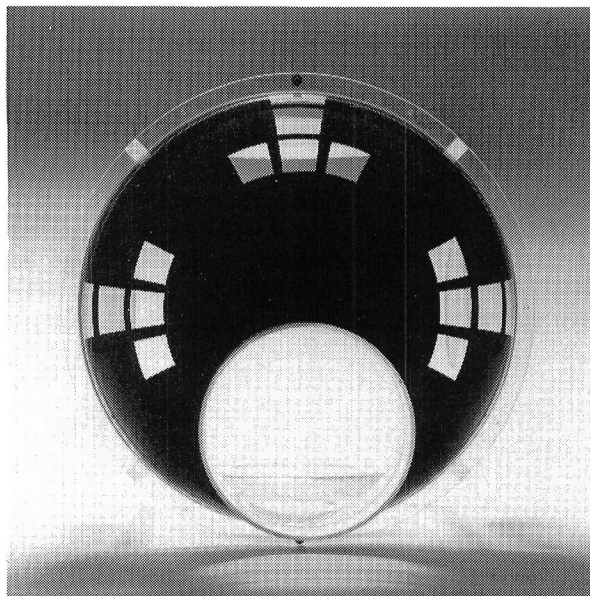

This arrangement of five windows is repeated 90 degrees to the left and 90 degrees to the right as well. This end-view photograph is of a scale model module end-cap with an off-center berthing port shown near the bottom. This arrangement of 15 separate windows offers a number of advantages which include: (1) overlapping fields of view by two or more crew who are viewing through different sets of windows, (2) wide field of view in both the horizontal and vertical directions simultaneously through any single set of five windows, and (3) use of standardized window assemblies in at least three of the five window locations. This window layout will also allow for radial rib construction radiating from a common center.

Figure 15 is a photograph taken inside the Proximity Operations Simulator at Ames showing the initial layout and construction of the windows. The following window design features may be noted with regard to each grouping of five windows: (1) The design eye volume is approximately 0.6 cubic m which permits a maximum horizontal field of view of 125 degrees arc and a maximum vertical field of view of just under 100 degrees. Excellent external situational awareness is ensured by this layout. (2) The two lateral windows flanking the center window are mirror images of each other in shape. (3) The two upper-most windows are identical.

Figure 15

Photograph of Full Scale Mockup During Construction
Showing Array of Five Prox-Ops Windows

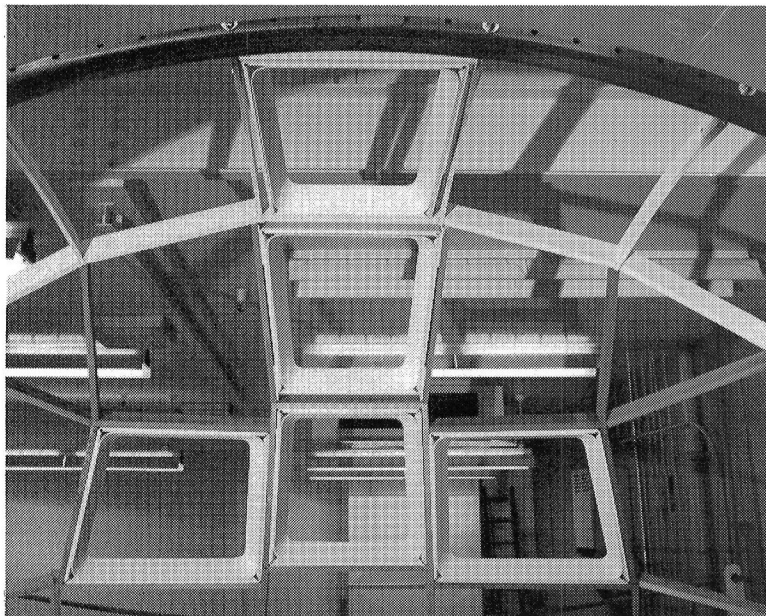

(4) All window frames are smallest at the outer glass surface, i.e., the frames are larger on the observer's side than on the space side. This ensures that the observer will always know that the maximum external scene is visible without having to move the head to make sure. (5) The top and bottom (horizontal) window frames are all parallel with the local horizontal of the Space Station. This feature aids in making judgments of the horizontality of approaching target vehicles when necessary. (6) The height of the center window is slightly raised relative to the height of the left- and right-hand windows which permits greater down-looking capability to each side. (7) All window frames are painted with a medium reflectance (approx. 65 percent) flat grey to ensure a low contrast window frame surround at

all times, i.e., the observer will always be able to see the window frame and use it to assist in making relative target motion judgements. (8) As many as five persons can view out of each group of five windows by assuming different body orientations relative to each other. As many as three persons can view out of each group of five windows when their body axes are parallel and their feet are in the same direction.

Other PROX-OPS station viewport concepts have been proposed by Bell and Trotti (1985) using a module connecting node as the location for viewing windows. They are reproduced in Figures 16 through 18. Each succeeding figure presents increasing FOV and exterior situational awareness. The hemispheric viewport proposed in Figure 18 appears to be beyond the current level of optical material processing in terms of keeping line of sight distortions at any penetration point to an acceptable level.

Figure 16

Flat Windows Located Within the Conncting Node Wall
(Concept by Bell and Trotti, Inc., 1985)

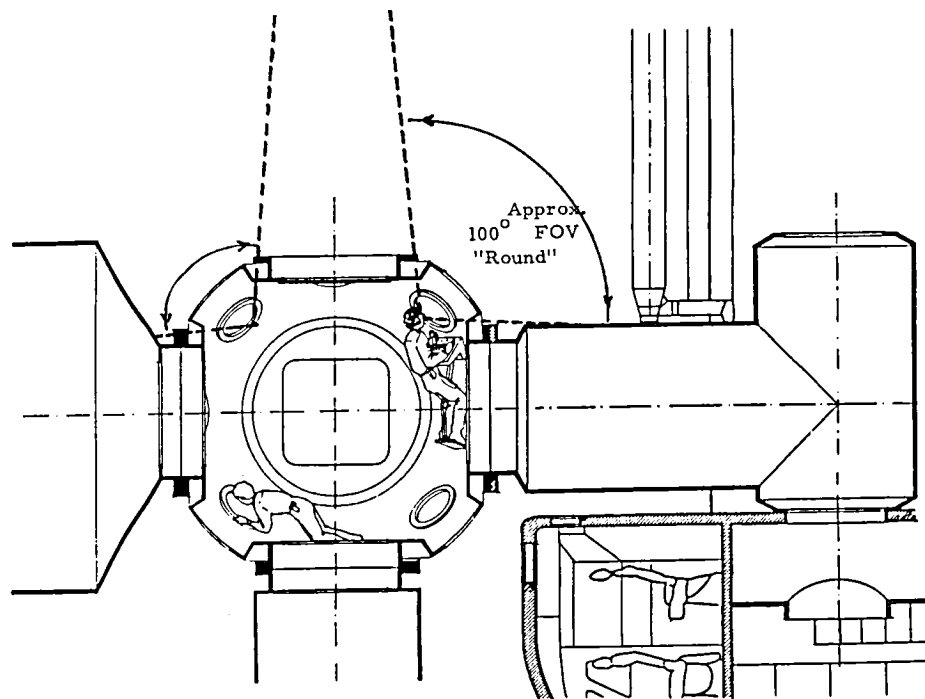
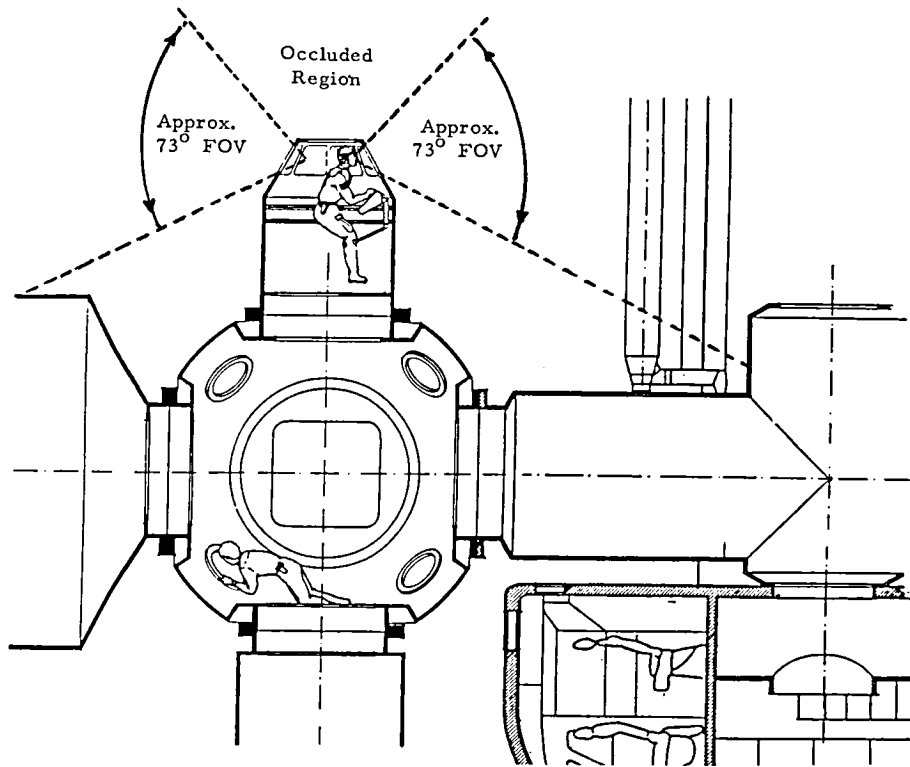

Figure 17

Flat Windows Located Within a Special Turret
Attached to a Connecting Node
(Concept by Bell and Trotti, Inc., 1985)



Referring to Figure 17, the turret concept affords excellent external visibility with a dedicated control station. It also permits flat glass panes to be used of moderately small dimensions.

Figure 18

Hemispheric Window Located Within a Special Turret
Attached to a Connecting Node
(Concept by Bell and Trotti, Inc., 1985)

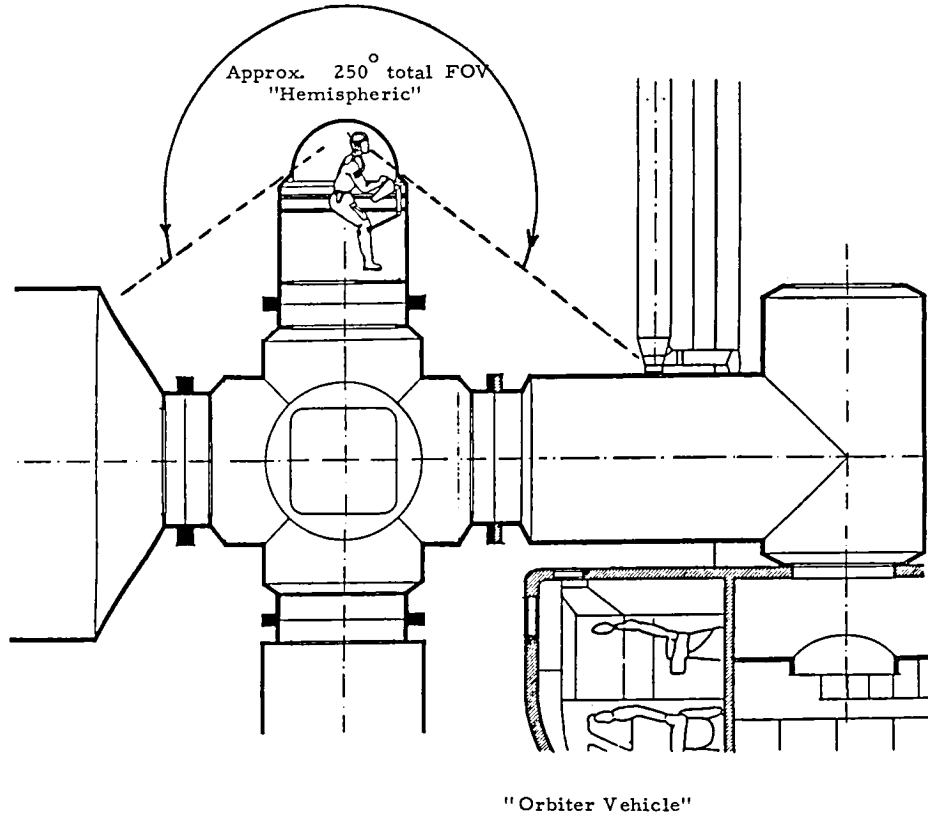

VI. FULL WINDOW ASSEMBLY REPLACEMENT

All manned U.S. space vehicles prior to Space Station have been flown back to earth (except Skylab). In most cases (e.g., Mercury, Gemini, Apollo) the capsule was not designed for more than one flight so that the windows were analyzed post-flight and then stored. The Orbiter windows are inspected after each flight with replacements/repair made as necessary on earth. For Space Station, however, it will be necessary to do all inspection, maintenance, and replacement on-orbit. This requirement raises some very interesting and challenging human factors questions and calls for new and creative structural designs.

Development of window pane crack development monitoring system should receive high priority along with the actual engineering design of the windows themselves. Such a monitoring system would significantly reduce the chance that small developing cracks would progress to a fracture point. Should an entire window assembly require replacement on-orbit, the human factors impact upon the entire crew would (likely) be enormous. One possible approach to window assembly replacement is illustrated in Figure 19 (from Bell and Trotti, 1985).

Figure 19

Full Window Assembly Replacement Concept
Proposed by Bell and Trotti (1985)

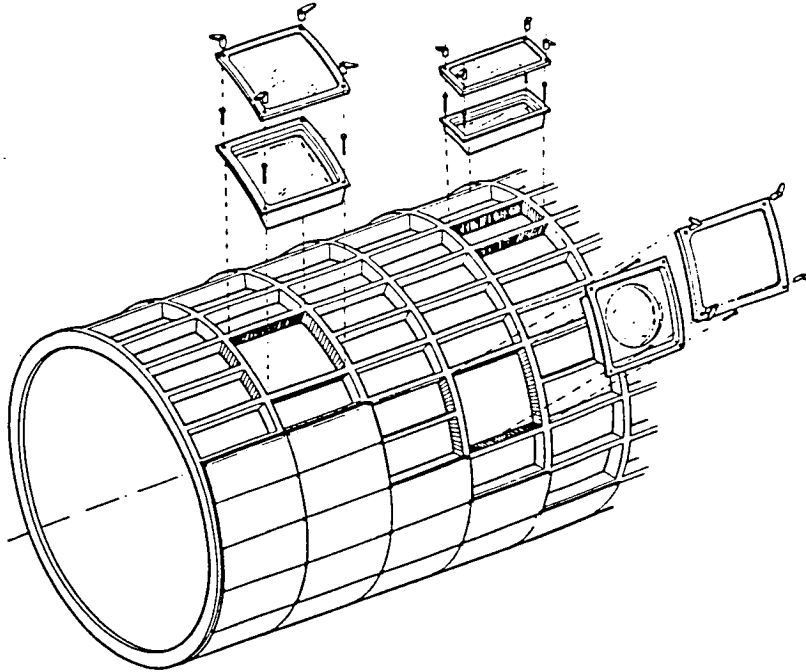

Some of the operational procedures which this approach would involve include: (1) all consequences of lowering the internal air pressure to zero (e.g., isolating the entire module or section of module, donning a pressure suit, etc.), (2) locating, unstowing, transporting new window assembly to installation area, (3) removing damaged window assembly, (4) cleaning and seating wall members to receive the new assembly, (5) cleaning, installing, and correctly seating the new assembly, (6) packing, marking, inventorying and stowing the damaged assembly, (7) repressurizing the module (or part of module), (8) performing window assembly integrity checks, and (9) preparing, unstowing, stowing, updating, referring to various procedural manuals.

VII. SUMMARY AND CONCLUSIONS

This brief presentation cannot begin to cover all of the myriad human factors associated with the design, placement, installation, check-out, monitoring, maintenance, spares storage, inventory control, and replacement of PROX-OPS windows. Some of these subjects are treated in greater detail elsewhere (Haines, 1986). This paper has outlined some basic design philosophy and assumptions for PROX-OPS windows for Space Station. The human factors engineer should be brought into the design process as early as possible in order to reduce the chance that critical window design characteristics will be incorporated which will reduce the operational capabilities of the windows.

VIII. REFERENCES

- Bell, L., G. Trotti, L. Hua, J. Brown, F. Winisdoerffer, and S. Ximenes: Space Station Viewport Study, NASA-Lyndon B. Johnson Space Center, Report JSC 32003, First Ed., December 1985.
- Donahoo, M.E., and C.C. Anderson: Shuttle Program - Space Station Operations, Vol. 3 - Proximity Operations, NASA-Lyndon B. Johnson Space Center, Report JSC-19371, February 1985.
- Griffin, B.N.: The Influence of Zero-G and Acceleration on the Human Factors of Spacecraft Design, Design Guide, NASA-Lyndon B. Johnson Space Center, Report JSC 14581, August 1978.
- Haines, R.F.: A Review of Peripheral Vision Capabilities for Display Layout Designers, Proceedings of the Society for Information Display, vol. 16, No. 4, Pp. 238-249, 1975.
- Haines, R.F.: Space Station Proximity Operations Windows: Human Factors Design Guidelines, NASA Technical Memorandum, (in press), 1986.
- Jackson, J., R. Bond, and R. Gundersen: Neutral Body Posture in Zero-G, Bulletin No. 17, Man-Machine Engineering Data Applications of Skylab Experiments M487/M516, July 1975.
- McDonnell Douglas Astronautics Co.: Space Station Definition and Preliminary Design, Orbital Operations Plan (DR-07) Appendix B, NASA Contract NAS9-17367, Internal Report No. MDC H2286, December 1985.
- Oberg, J.E.: Proximity Operations Flight Procedures Handbook, NASA-Lyndon B. Johnson Space Center, Report JSC-10566, November 11, 1982.

**From Spatial Displays to Spatial Instruments:
Perceptual Issues in the Design of Perspective Displays**

Stephen R. Ellis
NASA Ames Research Center
Moffett Field, Ca. 94035

I. The Search for the Natural Display

- A. Properties of a natural display
 - 1. Stimulus response concordance
 - 2. Appropriate resolution
 - 3. Minimum perceptual bias
- B. Spatial displays and spatial instruments
 - 1. Defn. of spatial display: photo or picture
 - 2. Defn. Spatial instrument: ruler in photo, clock
 - spatial properties of the display transmit quantitative spatial information to user at appropriate degree of approximation

II. Example of a Spatial Instrument: Cockpit Traffic Display

- A. TELERAN
 - 1. 1940's
 - 2. Old technology
 - 3. North-up plan-view
- B. Plan-view vs. perspective formats
 - 1. Better display of vertical separation
 - 2. Perspective projection, though natural is not enough
 - a. Not informative in itself
 - b. Potentially misleading
- C. Visual enhancements of perspective displays
 - 1. Symbolic
 - a. realistic models
 - b. grid for 3D sense and horizontal metric
 - c. reference lines clarify position & aspect
 - d. ownship relative metrical aids
 - 2. Geometric
 - a. projection to keep object in view w/ varying fov
 - b. scaling of aircraft independent of position for visibility
 - b. differential vertical/horizontal scale
- D. Pilots Behavior Effected by Difference b/ Plan & Perspective
- E. Generic perceptual issues

III. Definition of a Perspective Display

- A. Perspective parameters
 - 1. 3D geometry
 - a. 2 coordinate system: world and eye
 - b. center of projection, viewing vector
 - c. Azimuth, elevation, view plane or picture plane

2. 2D geometry
 - a. D - distance to reference point
 - b. d - distance to picture plane
 - c. FOV
3. Samples of effects of parameter changes
 - a. height of COP: effect on depicted direction
 - b. FOV changed alone: effect on size
 - c. Compensated FOV and D to keep part of picture constant: effect on distortion
- B. Visual enhancements
 1. Use of parameters to improve accuracy of spatial sense
 2. Addition of metrics and symbols

IV. Investigations of Perceptual and Motor Effects

Quantitative and objective development of geometric and symbolic enhancements

- A. Direction judgements
 1. The direction judgement task
 2. Examples of different FOV conditions w/ compensated size
 3. Distortion angle geometry: change FOV ~ eye not at COP
 4. Raw azimuth data showing FOV effect and fit
 5. Basic pattern of relative azimuth error
- B. 3D Cursor control
 1. Alternative measure of spatial sense
 2. Examine effect of azimuth and elevation of viewing vector
 3. Defn: of 3D tracking and example displays
 4. Coarse look at 3D tracking: monoscopic & stereo
 - defn: normalized RMS error
 - stereo better by enhancement equates mono
 - reference lines seem key for this task
 5. Finer look at perspective parameters
 - FOV alone
 - FOV & compensated distance D: distortion angle
 - Elevation angle: 45 deg optimum
 - Azimuth defn: and coarse look
 - Azimuth finer look at 1 subject: learning, optimum at 10 deg
 - Azimuth joystick rotation, relevance to camera angles

V. Future Directions: Window on the Synthetic Universe

- A. Other perceptual and control tasks & effects
 1. Pick and place robotics: = to 3D tracking, uncanny
 2. Visual acquisition: egocentric pointing
 - study of elevation parallel to azimuth
- B. Research questions for proximity operations displays
 1. Intuitive spatial displays for nonintuitive orbital dynamics
 2. Use of spatial displays in microgravity
 - affect on exocentric orientation?
 - egocentric orientation
 3. Three-dimensional target designation
 4. Proxop specific enhancements
 - local axes for communication: MMU example

C. Perspective display design recommendations

1. Field of view angle
2. Viewing vector direction and control axes
3. Scaling and center of projection
4. Metrical aids
5. Resolution of aspect ambiguity

D. Augmenting the Intelligent Eye

1. Gregories worries
2. Bekesy's equipment as an example
3. Role of visual enhancements in the synthetic universe

References

- Ellis, S.R, McGreevy, M.W., & Hitchcock, R.(1984) Influence of a perspective cockpit traffic display format on pilot avoidance maneuvers. *Human Factors Considerations in High Performance Aircraft AGARD Conference Proceedings No. 371*, 16.1-16.9.
- McGreevy, M.W. & Ellis, S.R.(1984) Direction judgement errors in perspective displays. Proceedings of the 20th Annual Conference on Manual Control. *NASA Conference Publication 2341*, 531-549.
- Ellis, S.R., Kim, Won Soo, Tyler, Mitchell, McGreevy, M. W. ,Stark, L. (Nov., 1985). Visual enhancements for perspective displays: perspective parameters. Proceedings of the International Conference on Systems Man and Cybernetics. IEEE Catalog # 85CH2253-3, 815-818.
- Kim, Won Soo, Ellis, S.R. Tyler, M., Stark, L. (Nov. 1985). Visual enhancements for telerobotics: perspective parameters. Proceedings of the International Conference on Systems Man and Cybernetics. IEEE Catalog # 85CH2253-3, 807-812.

IMAGE MANAGEMENT RESEARCH

Andrew B. Watson
Perception & Cognition Group, NASA Ames Research Center

Space Station Human Factors Research Review
December 3-6, 1985

What is an Image Management System ?

To begin with, what is an *image* ? I will take as a working definition any picture originally captured from life, as opposed to pictures generated digitally, which I will call *graphics* . Thus images are typically the result of a photographic process, either conventional or digital. Another distinction is that images are typically *pixel oriented* , while graphics are *object oriented* (eg lines, circles, areas etc). Now what is an image management system? Computers today provide an extensive set of tools for manipulating text, and a somewhat smaller and newer set for dealing with graphics. The next revolution will be the provision of tools for manipulating digital images. An image management system is a computer-based facility for capturing, coding, processing, editing, storing, analysing and displaying images.

Space Station Applications

What is the need for such systems on board the space station and in the various space station supporting centers? The current Space Station Flight Operations Requirements document, dated November 1985, is replete with references to the need for video interfaces among the station, platform, shuttle, omv's, and various ground control centers. (2.1.7.1, 2.1.9.1, 2.1.10.1, 2.2.3.1, 2.2.4.8, 2.2.6.6, 2.2.12.4, 3.1.5.1). While perhaps originally conceived as analog video hook-ups, it seems highly likely that the advantages of digital video will eventually lead to its adoption, particularly in during EOC.

Elsewhere it is stated that these video links must be part of a highly reconfigurable "General Purpose workstation" (2.2.4.7, 2.2.4.8), which can only be done effectively via digital video. This integration of digital video into general workstations is itself an image management problem.

The requirements document also deals at some length with training, noting the need for video aids (2.1.11.3). This presumably refers to video disc, with its invaluable capacity for random access. It is further stated that comparable training must be provided on board the space station (2.2.9.1). We are thus lead to assume that the space station will include onboard storage for large random access libraries of training images.

Elsewhere it is stated that "Automated training shall utilize operational onboard equipment in a simulation mode." (2.2.9.4) Since most operations will require visual/video monitoring, this would seem to require an onboard library of imagery to accompany the simulation.

Other space station image databases can be imagined, such as parts directories, archives of scientific imagery, repair manuals, personnel directories, and so on.

Research Issues

What are the research issues involved in image management systems? They divide into two sorts: image processing research and image perception research. The image processing issues are the traditional ones of digitizing, coding, compressing, storing, analysing, and displaying, but with a new emphasis on the constraints imposed by the human perceiver. For example, the efficiency of a coding scheme is considered not with respect to statistical efficiency alone but also with respect to perceived fidelity. We have made some progress in this area and have developed two image coding algorithms that may greatly increase the efficiency of an IMS.

The second category, image perception research, involves a study of the theoretical and practical aspects of visual perception of electronically displayed images. We are interested in issues such as how rapidly a user can search through a library of images, and how to make this sort of search most efficient? Is it best to present each image at full size and full resolution, or is it better to present many images at once at reduced size and resolution? This raises a fundamental question, namely, what are the effects of size and resolution upon the speed and accuracy with which humans recognize images. We have experiments on this question underway at the moment.

Another set of issues relate to the optimal interface to an IMS. What image manipulations should the user be able to do? Zooming? Moving images about the screen? Accessing additional textual data about the image? Subtracting two images? More general image processing operations? Some of these are no doubt useful in particular applications but is there a set which are highly useful in the "generic" setting?

Another large and fascinating issue is how to code images in a way that is optimal for the human perceiver. Recent research in our group suggests that an understanding of human spatial and color perception may provide ways to massively reduce data requirements without sacrificing visual fidelity. To give but one example, it is well known that color vision has lower spatial resolution than pattern vision, and an image coding method which could take advantage of this would result in a massive data compression. One algorithm that we have developed, which separates an image into separate bands of resolution, provides a natural way of doing this.

IMS Test-Bed

We have designed a test-bed within which many image management issues can be addressed. It consists of a high performance UNIX workstation with a very high resolution color framebuffer and display. The workstation hosts a digitizer, an array processor, and an optical video disc recorder.

The typical scenario is that the user, communicating through an interface resident on the workstation, requests an image or set of images. The locations of these images on the optical disc are determined by a database resident on the workstation. The images are played back and captured by a digitizer. The digitized images are processed by the array processor and displayed with desired size, location, and timing on the high resolution framebuffer. Images can be recorded on the optical disc (and entered into the database) either from a video camera or from the digitizer. This configuration sacrifices something in speed to obtain the high degree of flexibility suitable to a research, rather than production, environment. It is currently about 75% complete. When complete, it will have the following capabilities:

Capabilities of Test-Bed

- rapid acquisition from large (24,000) image database

- rapid digital processing of selected images

- display of multiple images of arbitrary size on single screen

- arbitrary presentation rate of full-size images

- database management of image library

- supervisory control of all functions from UNIX workstation

Conclusion

There is no question that image management systems will become an integral part of the information systems of the near future, and it is almost as certain that they will become part of the space station. We hope that our research will help make that system powerful and useful, and generally contribute to the efficiency of space station operations.

IMAGE MANAGEMENT RESEARCH TEST-BED

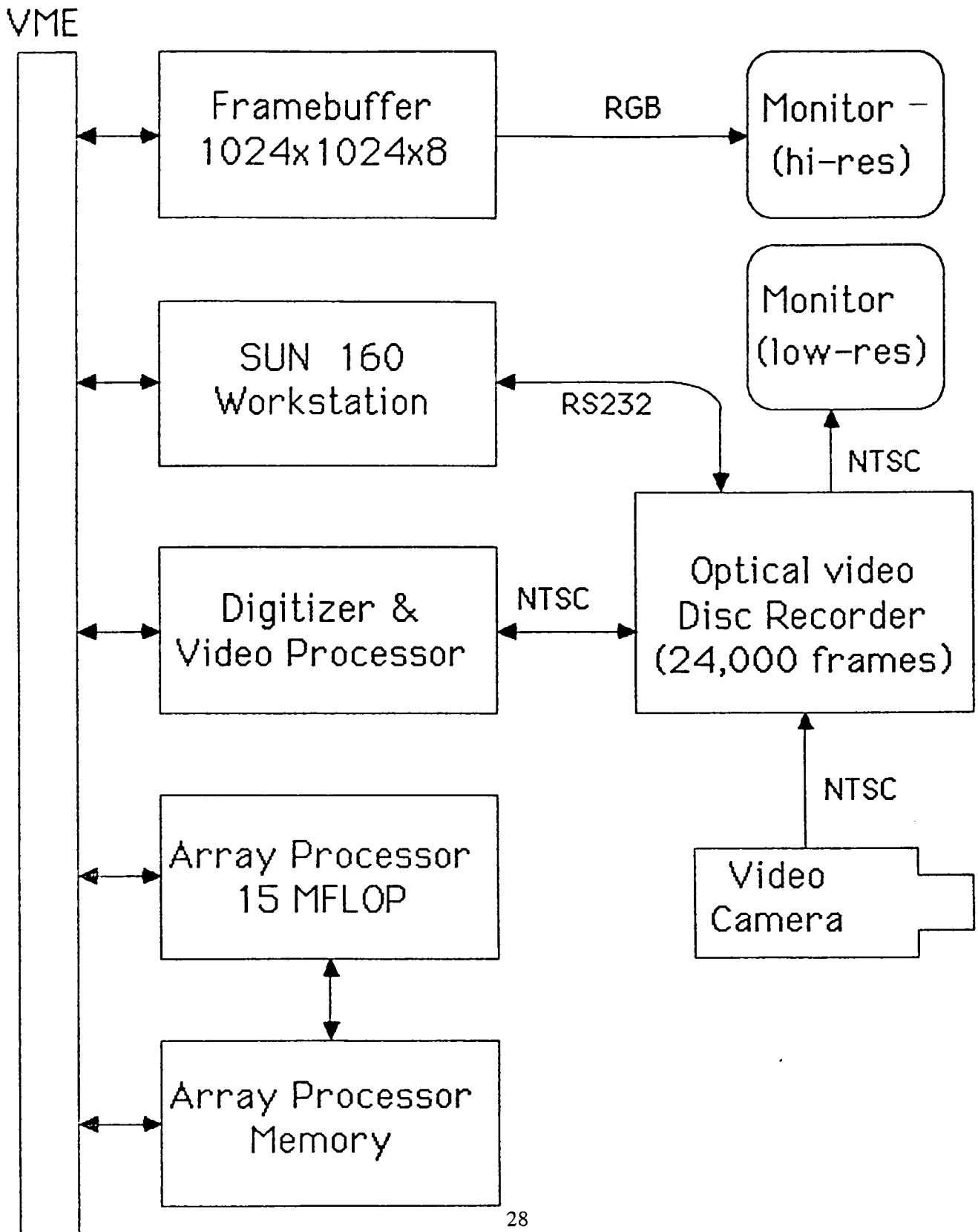

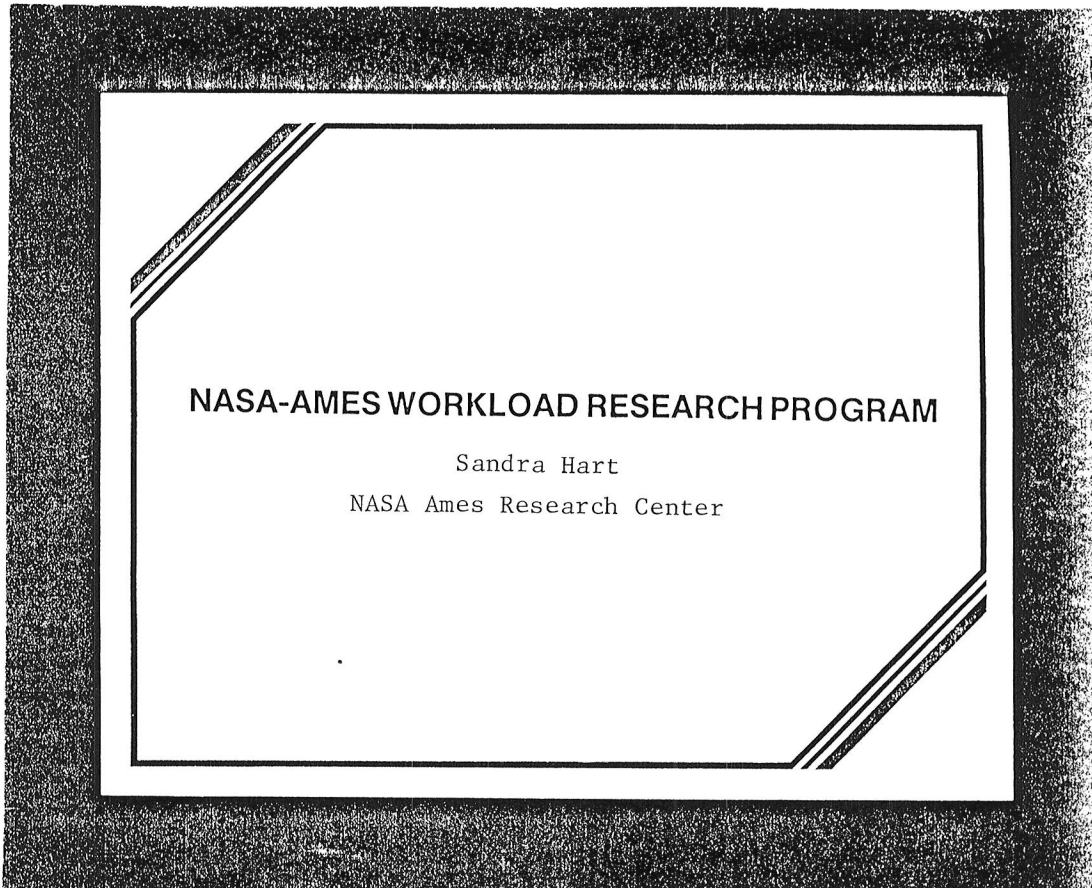

During the next hour, I will describe the purpose, philosophy, structure, and some of the accomplishments of the Human Performance Research Group of the Aerospace Human Factors Research Division. I will try to demonstrate the flow of information from generic, theoretical research to specific space-station related applications.

Although an increasing emphasis has been placed on providing computer-based automation in every phase of modern systems, the decision has been made that man will continue to play a central role in space station operations. Humans have capabilities beyond those of the most sophisticated computer systems and their flexibility and adaptability provides a unique asset in such a remote environment. The activities that will be performed in the Space Station range from direct control of spacecraft (e.g., the orbiter, the orbital transfer vehicle, and the manned maneuvering unit) to indirect control (e.g., the orbital maneuvering vehicle and the remote manipulator arm), to housekeeping activities and the conduct of scientific experiments. Each will require specialized training, take a certain amount of very limited and precious time and will have some associated human (e.g., workload) and payload cost.

The space station provides a unique situation in which teams of astronauts, scientists, and technicians will live and work in an unfamiliar environment for prolonged periods of time. Space flight has traditionally required high levels of performance in relatively stressful environments. The stressors may include isolation from familiar work and living surrounding, physiological discomfort associated with weightlessness, and potentially high levels of workload. Major changes in the U. S. Space Program may precipitate additional problems, such as longer missions,

heterogeneous crews, more varied and complex tasks, and an expected decrease in the training provided for individual crewmembers. The increased emphasis on space commercialization will require crewmembers to exhibit new levels of productivity.

Even though previous space missions have proven to be extremely successful, the available evidence suggests that the performance and reliability of the human elements of aerospace systems is currently lower than that of other elements. Studies of human reliability show that most human-related errors involve inadequate or faulty crew coordination and inadequate or faulty man-machine interface. These problems are soluble. One of the goals of our program is to evaluate ways to predict the impact of performing a large range of tasks on the human operator and to provide guidelines for design and operation to enhance system performance and optimize human behavior and experience.

It is important to assign humans those tasks with which they can excel and to redesign, aide, automate, or eliminate those tasks which they perform poorly, unreliably, or with unacceptably high levels of workload. In addition, the presentation of information and control inputs must be designed so as to optimize human capabilities. In order to accomplish this, predictors and measures of human performance and workload are needed to evaluate the effectiveness of display, control, and automation options so as to maximize the efficiency, effectiveness and reliability of the human element in a man-machine system. This information is required early in the design and construction process, as retrofits and modifications are costly and time-consuming, if not impossible, once the actual construction process of the space station has begun.

Traditional measures of human performance (which focus on lower level, in-the-loop control) may not be applicable for high-level supervisory control tasks nor the measurement of productivity, efficiency, information seeking, decision making or control strategy for teams of operators. In addition, the impact of crewmembers' efforts to accomplish mission requirements on the human operators themselves (e.g., workload) is an important design consideration.

OUTLINE:

- o ORGANIZATION OF PROGRAM
 - PROBLEM/OBJECTIVES/APPROACH
 - RESOURCES
 - COLLABORATION
 - CONCEPTUAL FRAMEWORK
- o CRITERION TASKS
- o PREDICTIVE MODEL
- o ASSESSMENT TECHNIQUES
 - PERFORMANCE
 - PHYSIOLOGICAL
 - SUBJECTIVE
- o VALIDATION/APPLICATION OF TECHNIQUES

Research has been underway at Ames for several years to develop valid and reliable measures and predictors of workload as a function of operator state, task requirements, and system resources. Although the initial focus of this research was on aeronautics, the underlying principles and methodologies are equally applicable to space, and provide a set of tools that NASA and its contractors can use to evaluate design alternatives from the perspective of the astronauts. I will begin by describing the objectives and approach of the research program, the resources used in conducting research, and the conceptual framework around which the program evolved. Next, I will describe the standardized tasks, predictive models and assessment techniques we have developed, and their application to the space program. Finally, I will review some of the operational applications of these tasks and measures.

PROBLEM:

- o NONOPTIMAL LEVELS OF WORKLOAD IMPOSED ON THE HUMAN OPERATORS OF ADVANCED SYSTEMS ARE A SIGNIFICANT FACTOR IN THE EFFICIENCY AND SAFETY OF SYSTEM OPERATIONS, OVERALL SYSTEM PERFORMANCE, TRAINING REQUIREMENTS, ADDITIONAL HARDWARE AND SOFTWARE COSTS, CREW COMPLEMENT, AND JOB SATISFACTION.
- o SINCE WORKLOAD REFLECTS THE INTERSECTION BETWEEN A PARTICULAR OPERATOR PERFORMING A SPECIFIC MISSION, USING THE AVAILABLE HARDWARE, SOFTWARE AND HUMAN RESOURCES, WORKLOAD HAS MULTIPLE CAUSES AND EFFECTS.
- o THUS, DIFFERENT WORKLOAD QUESTIONS AND CIRCUMSTANCES REQUIRE DIFFERENT MEASUREMENT TECHNIQUES.
- o STANDARDIZED, VALIDATED, AND SENSITIVE MEASURES ARE NOT YET AVAILABLE TO EVALUATE THE WORKLOAD OF EXISTING SYSTEMS NOR TO PREDICT THE WORKLOAD OF PROPOSED SYSTEMS DURING THE DEVELOPMENT PROCESS.

A resurgence of interest in the field of workload assessment was prompted by the President's Task Force on Crew Complement. It became clear that the question of whether or not two or three crewmembers would be required for the next generation of aircraft could not be answered satisfactorily without a clear concept of what factors affected crew workload, how workload could be measured, how much workload is too much (or too little), the relationship between measures of workload and performance, and the effectiveness of automation in reducing or redistributing workload.

Our initial premise was that nonoptimal levels of workload are a significant factor in efficient and safe system operations, training requirements, required hardware and software, crew complement, and job satisfaction. Since workload reflects the intersection between a particular operator performing a particular mission, using the available hardware, software and human resources, workload may have multiple causes and effects. Thus, different workload-related questions and circumstances require different measurement techniques. Even more important, for practical reasons, is the need for standard, valid, sensitive techniques to predict the workload of proposed systems early in the design process.

"COST" OF FULFILLING MISSION REQUIREMENTS

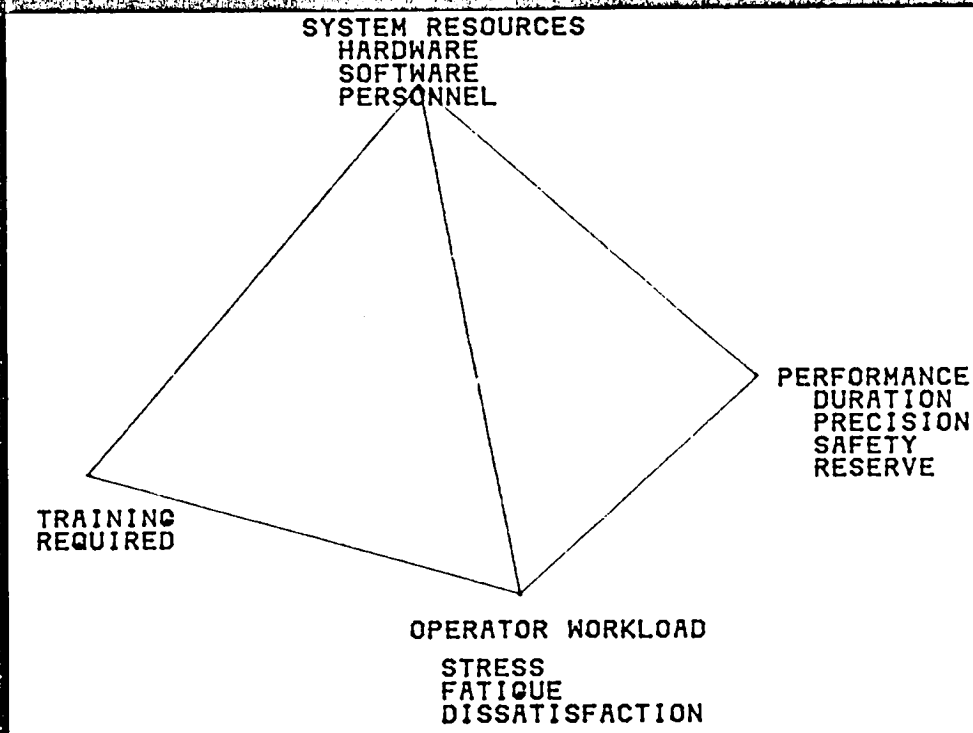

The "cost" of fulfilling mission requirements can be conceptualized in many ways. It can be quantified in terms of system resources required; the amount and sophistication of hardware and software required and the number and qualifications of personnel. The cost of the training required for crewmembers to accomplish mission objectives using existing equipment can be quantified as well, as can the cost of failure to meet mission objectives. We define the "cost" to human operators of performing their part in a man-machine system as workload. Workload is more difficult to quantify in objective terms than the other costs of system performance. Its impact may be evaluated indirectly, however, through lowered levels of performance, additional required resources or training, and operator dissatisfaction. In order to meet mission requirements, there may be a tradeoff between additional resources, additional training or higher levels of workload. If operators are already working at their peak efficiency, then lower levels of performance might have to be accepted or additional system resources provided.

PROGRAM OBJECTIVE:

DEVELOP AND VALIDATE TECHNIQUES TO PREDICT AND ASSESS THE EFFECTS OF TASK DEMANDS, ENVIRONMENT, AND TRAINING ON OPERATOR BEHAVIOR, WORKLOAD, AND PERFORMANCE.

APPROACH:

PERFORM GENERIC RESEARCH TO DISCOVER UNDERLYING PRINCIPLES, DEVELOP AND VALIDATE ASSESSMENT TECHNIQUES, AND CREATE PREDICTIVE MODELS.

PERFORM VEHICLE-SPECIFIC APPLICATIONS OF GENERIC CONCEPTS AND METHODS TO ADDRESS OPERATIONAL PROBLEMS.

Our assumption is that workload is a hypothetical construct that represents the cost to human operators of achieving mission objectives. Thus, our definition is human-centered, rather than task-centered. An operator's experienced workload represents many other factors in addition to the objective demands placed on them. It is not an inherent property of a task but emerges from the interaction between the requirements of the task, the skills and behaviors of an operator, and the circumstances under which the task is performed.

The initial goal of the program was to develop measures and predictors of human workload that took into account all of the relevant factors. Several parallel lines of research were undertaken in which underlying principles were discovered, measurement techniques developed and validated, and predictive models created. Vehicle-specific applications of these generic concepts and methods were performed concurrently to address a variety of operational problems.

NASA/ARMY-SPONSORED WORKSHOP

OBJECTIVE: EXAMINE THE ASSOCIATIONS AMONG WORKLOAD, TRAINING, AND PERFORMANCE. IDENTIFY WHAT IS ALREADY KNOWN AND IMPORTANT ISSUES THAT REQUIRE RESEARCH.

APPROACH: CONDUCT A FIVE-DAY WORKSHOP IN WHICH EXPERTS IN TRAINING, WORKLOAD, AND ADVANCED SYSTEMS WILL BECOME FAMILIAR WITH EACH OTHERS' DISCIPLINES AND CONSIDER SPECIFIC QUESTIONS:

- o WHAT IS THE EFFECT OF EXPERTISE ON WORKLOAD?
- o IMBEDDED TRAINING
- o EXPERT SYSTEMS/COMPUTER-BASED TRAINING
- o INDIVIDUAL DIFFERENCES IN WORKLOAD AND TRAINING

PRODUCT: PUBLISHED BOOK EDITED BY DR. EMANUEL DONCHIN THAT INCLUDES INVITED ADDRESSES AND SUMMARIZES PANEL DISCUSSIONS.

SCHEDULE: 10/86 (FUND GRANT TO UNIVERSITY OF ILLINOIS)
1/86 (CONFERENCE)
9/86 (PUBLICATION)

The initial focus of the research was on assessment. The focus moved toward prediction as the theoretical problems associated with assessing workload in existing systems were resolved. I will describe the results of this research in greater detail in a moment. More recently, our focus has been on training. Specifically, we wish to investigate the interrelationships among workload, training, and performance in highly automated systems, such as the LHX helicopter and the space station.

The focal point of this area of research is a workshop sponsored by NASA that will be held in January. The workshop participants will consider how to quantify and predict performance and workload changes as training progresses, and, conversely, to determine the role of workload in training effectiveness. The proceedings of this workshop will be published in a book for public dissemination. The specific focus of the discussions will be on the two vehicles that represent two workload and environmental extremes faced by technology - - single-pilot, nap-of-the earth helicopter flight at night during the performance of Army missions and Space Station operations. Training may well emerge as a significant problem area in space station operations. Due to new mission goals and characteristics, it is anticipated that the training time allowed for space station operators will be reduced. Some of the training now accomplished on the ground may be performed in orbit and recurrent training may be required on orbit due to the extended mission durations. More effective and efficient training programs, particularly those that focus on understanding and operating highly automated subsystems, will be needed to maintain workload and performance at acceptable levels.

RESEARCH GRANTS FUNDED BY THE PROGRAM

* VIRGINIA POLYTECHNIC INSTITUTE	WIERWILLE
* ARIZONA STATE UNIVERSITY	DAMOS
* UNIVERSITY OF CALIFORNIA, LOS ANGELES	LYMAN
* OHIO STATE UNIVERSITY	JENSEN
* SAN JOSE STATE UNIVERSITY	JORDAN
* MASSACHUSETTS INSTITUTE OF TECHNOLOGY	SHERIDAN
* U.S. AIR FORCE ACADEMY	SWINEY
* SANTA CLARA UNIVERSITY	SWEENEY
* UNIVERSITY OF ILLINOIS	WICKENS, KRAMER
* PURDUE UNIVERSITY	KANTOWITZ
* UNIVERSITY OF TORONTO	MORAY
* TECHNION, ISRAEL INSTITUTE OF TECHNOLOGY	GOPHER
* BEHAVIORAL INST. TECHNOLOGY AND SCIENCE	KANTOWITZ, TOWNSEND
* UNIVERSITY OF SOUTHERN CALIFORNIA	HANCOCK
* WAYNE STATE UNIVERSITY	FRANKEL
* STANFORD UNIVERSITY	CALFEE

RESEARCH CONTRACTS FUNDED BY THE PROGRAM

* GENERAL PHYSICS CORPORATION	GOMER
* STRUCTURAL SEMANTICS	LINDE, GOGUEN
* STANFORD RESEARCH INSTITUTE	CHESNEY
* DOUGLAS AIRCRAFT COMPANY	BIFERNO
* SEARCH TECHNOLOGY	ROUSE

Our program represents an active collaboration between inhouse research, joint research with other government agencies and industry, and research funded through grants and contracts. The personnel involved in the program include psychologists, pilots, and engineers. The facilities used range from laboratory settings to part-task simulations, full-mission simulations, and inflight experiments. The research efforts differ with respect to theoretical perspective, assessment techniques used, research facilities, and focus (theoretical or applied, prediction or assessment). For each critical area, several different lines of research have been undertaken. Coordination and integration has been accomplished through publications and scientific presentations, meetings, and shared experimental tasks and measurement techniques.

INTERACTIONS WITH OTHER AGENCIES: COLLABORATIVE RESEARCH

- * ARMY (CDEC) SCOUT II Helicopter Experiment
- * ARMY (AVSCOM) COBRA/Pilot Night Vision System Inflight Training
 1 vs 2 Pilot (ADOCS Simulation in VMS)
 ARTI Contractor Simulations-Government scenario
- * NASA-JSC Space Suit Comparison
 RMS Workload Prediction/Evaluation
- * FAA TCAS Workload Evaluation (MVSF B-727 simulator)
- * Navy (NATC) Tilt-rotor Workload Evaluation
- * Air Force (Brooks) Pilot Recertification Test Battery
- * British CAA North-Sea Oil Operations Workload Evaluation

We have played a support role in a number of simulation and inflight experiments conducted by outside organizations. In general, we provided workload assessment methodologies and application procedures to assist these organizations in addressing operationally relevant workload-related problems.

MANPRINT

MANPOWER & PERSONNEL INTEGRATION



- HUMAN FACTORS ENGINEERING
- MANPOWER
- PERSONNEL
- TRAINING
- SYSTEMS SAFETY
- HEALTH HAZARD ASSESSMENT

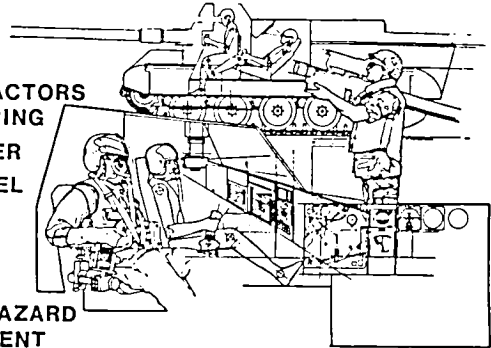

NASA CONTRIBUTION:

- o BRIEFING: OVERVIEW OF WORKLOAD AND PERFORMANCE ASSESSMENT RESEARCH
- o COURSE SYLLABUS: BASED ON NASA WORKLOAD REPORT
- o COMPUTER-BASED TRAINING PROGRAM: NASA "EXPERT" SYSTEM FOR SELECTING WORKLOAD ASSESSMENT METHODOLOGY

Operational validity and applicability have been insured by frequent involvement in addressing operational problems posed by members of other organizations. One example of such involvement is the role that we played in the development of the Army MANPRINT course. This program represents a major effort by the Army to integrate human factors issues, manpower and personnel, and training into the materiel acquisition process. The results of our research provided the foundation for the course presented by the Army to familiarize Army managers with human factors engineering and several of the programs developed at Ames will be used as teaching aides.

COLLABORATIVE RESEARCH:
 ADVANCED DIGITAL OPTICAL CONTROL
 SIMULATION (ADOCS)

OBJECTIVE:

- (1) COMPARE ONE vs TWO PILOT WORKLOAD
- (2) COMPARE WORKLOAD OF DIFFERENT COMBAT MISSIONS
- (3) EVALUATE WORKLOAD IMPACT OF DIFFERENT LEVELS OF AUTOMATION

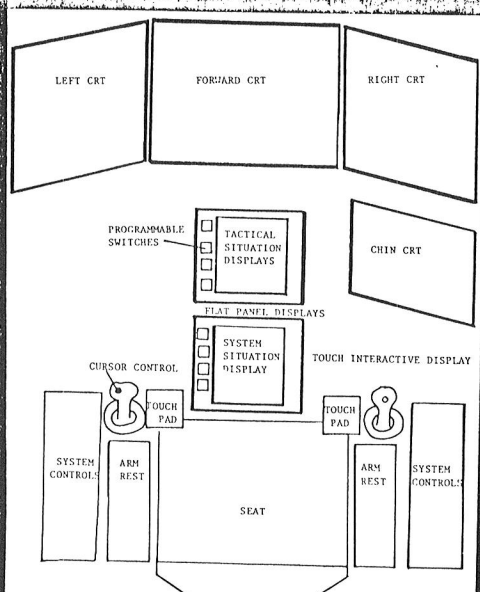
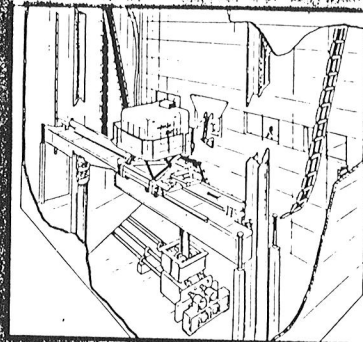

APPROACH:

- (1) CONDUCT SIMULATED NOE COMBAT MISSIONS IN VMS
- (2) DISPLAYS: HMD, TSD, SMD, TOUCH PANEL, BUTTON I/O
- (3) CONTROLLERS: CONVENTIONAL, SIDEARM
- (4) WORKLOAD MEASURES:
 INFLIGHT AND POSTFLIGHT RAT
 HEART RATE AND VARIABILITY
 HOVER/BOB-UP TIME ESTIMATES

One example of such joint research is a recent simulation which we completed with the Army Aeroflightdynamics Division. The goal of this study was to compare the workload of pilots flying one- or two-pilot configurations with different levels of automation. The tasks represented missions that an LHX-type helicopter might perform in the 1990s. The flights were performed in the Ames Vertical Motion Simulator using the Advanced Digital Optical Control Simulation (ADOCS).

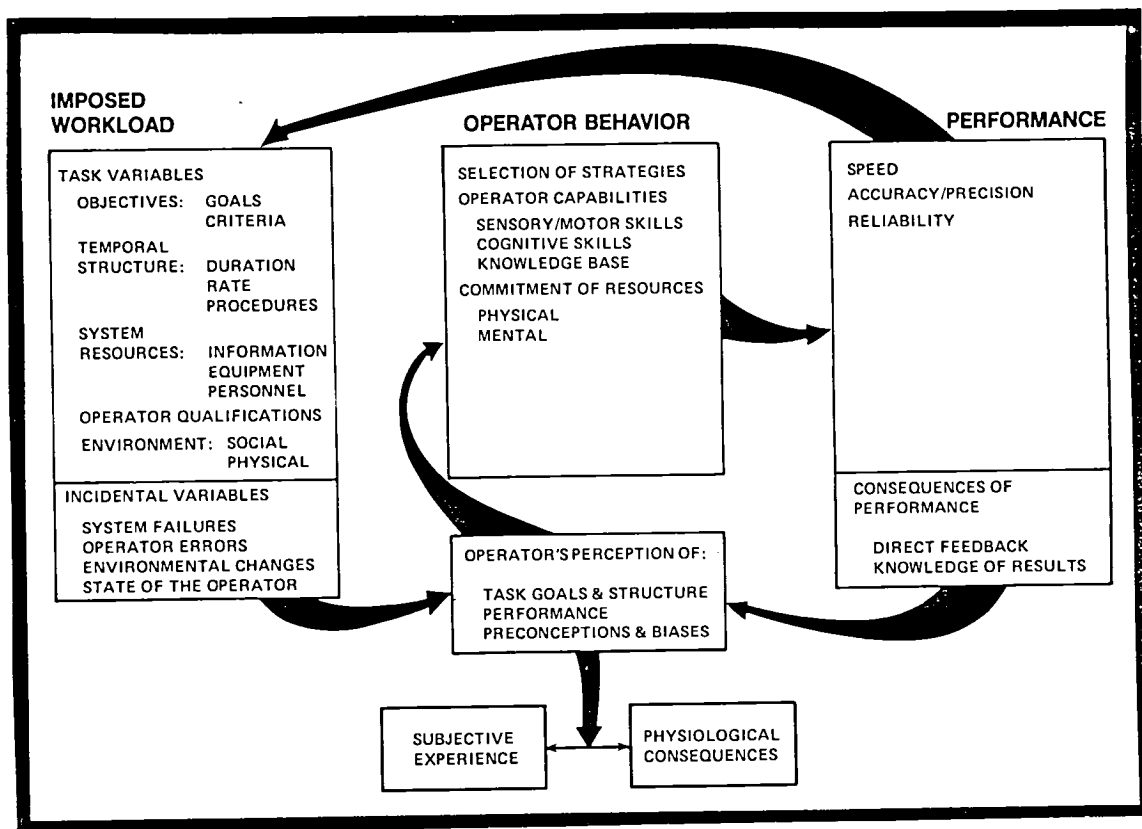

As I mentioned before, the focal point of the program was a conceptual model in which task-related, behavior-related, and operator-related variables were related to each other. Imposed workload refers to the situation encountered by a specific operator or team of operators in performing a task. The intended demands of a task are created by its objectives and performance criteria, temporal structure, system resources provided and the environment in which it is performed.

Task objectives are particularly critical because they determine the target performance levels that operators attempt to achieve. The temporal structure of the task refers to the length of time available to perform the task or subtask elements, the degree to which task elements overlap in time, the procedures and organization, and the degree to which operators can select which tasks to perform and in which order. The objectives and temporal structure of a task create the task requirements. This can be distinguished from the workload associated with the system resources provided to the operators to perform such a task.

System resources refer to the information, equipment, controls, displays, and personnel that are provided to assist the operator in performing the task. System resources include automation that has become such an important element in most advanced systems. A major focus of our research program has been to investigate the workload-impact of different types of automation on operator workload. In general, the trend has been to reduce the physical workload of operators and to remove them from in-the-loop control activities, but often at the cost of an increase in mental workload. An additional concomitant of automation has been to alter the nature and impact of operator errors - relatively "minor" typographical

errors can lead to extremely grave consequences that are difficult to detect because the operator is not sufficiently integrated into the performance of the system.

The environment can have a significant effect on operator workload and performance. The social environment, that is crew interactions, leadership styles, group dynamics, can all play a significant role in the safe and efficient functioning of a crew. This particular issue will become particularly salient in space station operations, where crew members live and work together in a very confined environment for a prolonged period of time. The physical environment refers to the workstation layout, personal space, climate, threat from man-made or natural sources.

Each time a particular task is performed by a specific operator, incidental variables may occur that can alter the workload demands of the task either subtly or substantially. In this regard, the primary focus of our research efforts has been to examine the role of system failures and operator errors on subsequent task performance and crew workload. We consider errors to be a potent source of workload rather than an indicator of workload. The disruption caused by errors is particularly acute for well-trained operators, as they must step out of over-learned, automatic patterns of behavior to diagnose and solve the error and then continue with the interrupted activities with conscious attention.

System response refers to the behavior and accomplishments of a man-machine system. Operators are motivated and guided by the imposed demands, but the strategies selected and effort exerted reflects the operators perception of what it required of them. In most tasks, a variety of strategies are possible and different tasks, obviously, required different skills and capabilities. Thus, the role of human behavior in workload can be complex. Physical effort is the easiest to conceptualize and measure, but its contribution to advanced systems is diminishing. The problems associated with physical effort exerted in zero-G environments should be relatively unique, as the astronauts cannot rely on highly overlearned (and thus automatic) patterns of motor behaviors learned in a one-G environment. This source of workload - - that is the conscious attention to physical activities that are normally performed without conscious attention should be relatively great early in a mission, but should be reduced as time on orbit increases, and new patterns of response are developed. Mental effort serves as a potent intervening variable between measurable stimuli and measurable responses but it is difficult to quantify directly. It is unlikely that this aspect of human workload should be affected significantly by a zero-G environment, except for those aspects involved with motor control and spatial orientation.

Performance represents the product of the operators' actions and the limitations, capabilities and characteristics of the system controlled. Performance feedback provides information to the operators about their success in meeting task requirements, the appropriateness of the strategies selected, and the level of effort exerted, allowing them to modify their behavior to achieve more acceptable levels. We have examined performance from two perspectives: (1) As an indicator of the degree to which operators were able to satisfy task requirements and (2) As an indicator of the cost incurred by the operator in doing so. Performance levels tend to remain fairly constant as long as the task requirements remain within the operator's capabilities. In this case, performance measures do not reflect

the increasing levels of effort associated with meeting progressively increasing task demands. When performance requirements exceed operators' capabilities, or they lower their performance standards, decreasing levels of performance may in fact reflect the existence of higher levels of workload.

The consequences of performing a task on an operator can be physiological or subjective. Since operators may not be aware of every task variable, the processes that underly their decisions and actions, or the influence of preconceptions about the task, workload experiences may not reflect all of the relevant factors and may, in fact, reflect some that are irrelevant. Thus, we draw a distinction between the level of workload that a system designer intended to impose on an operator, the responses of a specific man-machine system to the task, and the operators' subjective experiences. The importance of subjective experiences extends beyond their association with subjective ratings, however. The phenomenological experiences of human operators affects subsequent behavior, and thus, performance. If operators consider the workload of a task to be excessive, they may adopt strategies that are appropriate for high workload situations (such as shedding tasks, hurrying, or accepting lower levels of performance) and they may experience physiological or psychological distress.

One example of a misperception of task requirements was presented to us by JSC as a problem requiring an experimental solution. The mission commander on an early Shuttle flight reported experiencing "time compression" during approach and landing - - that is the feeling that time was passing too quickly. One suggestion was that experiencing zero-G had somehow disrupted his ability to perceive the passage of time accurately. The more likely explanation, based on a series of experiments, was that failures of time perception is a common concomitant of stress and high levels of workload.

Physiological responses may reflect momentary responses to task demands (such an elevated heart rate or pupil dilation) or relatively long term effects following prolonged exposures. It might be expected that this aspect of operator's responses to workload might be relatively more extreme in orbit, as task-related stressors might interact with environmental stressors associated with zero-G.

CRITERION TASKS DEVELOPED
AT AMES:

- o FITTSBERG
- o POPCORN
- o MULTI-COCKPIT
SIMULATION
- o STANDARD FLIGHT
SCENARIO MODEL

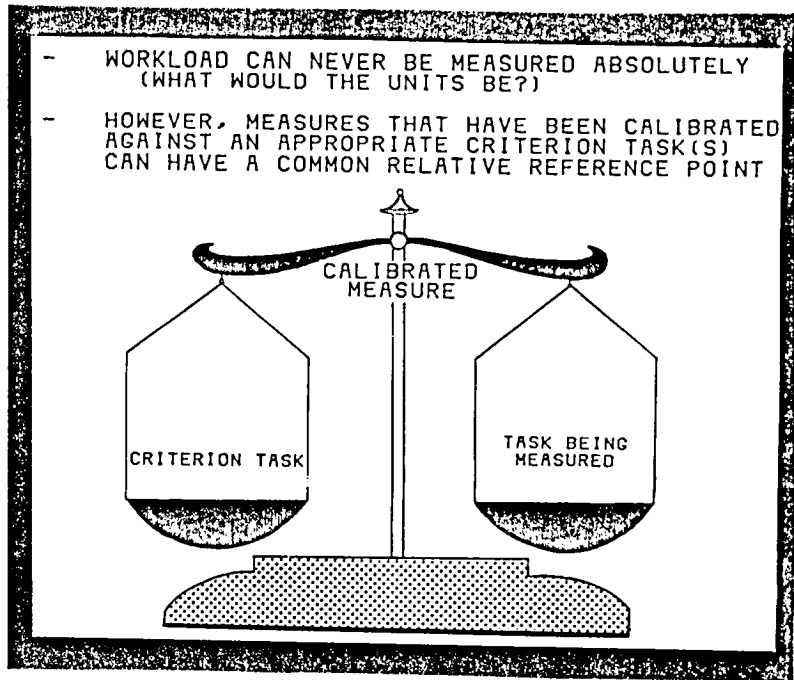

The fact that workload validation procedures are often circular presents a significant problem in the development and validation of candidate workload measures. since there is no objective standard against which a measure can be compared, the decision of whether or not it is sensitive is often made ad hoc. That is, if the measure varied in accordance with the supposed levels of workload imposed by the task, the assumption is that it is sensitive, and if it does not, it may either indicate that the measure was not sensitive or that the experimenter did not, impose the intended levels of workload.

For this reason, we have developed a set of "criterion tasks", for which standardized levels of workload can be created according to well-known psychological principles. These tasks represent stylized versions of the activities that operators normally perform in advanced systems. Candidate measures or models can then be compared against known workload levels imposed by these tasks. I will describe two such tasks.

CRITERION TASKS: FITTSBERG

OBJECTIVE:

DESIGN A SIMPLE, RELIABLE, AND FLEXIBLE LABORATORY TASK IN WHICH TASK ELEMENTS ARE FUNCTIONALLY RELATED BUT:

- (1) RESPONSE SELECTION AND RESPONSE EXECUTION DIFFICULTY CAN BE MANIPULATED INDEPENDENTLY
- (2) PERFORMANCE ON SUBTASK ELEMENTS CAN BE MEASURED INDEPENDENTLY

APPLICATIONS:

- (1) IDENTIFICATION OF SUBTASK ELEMENTS TO AUTOMATE
- (2) DISPLAY MODALITY (AUDITORY/VISUAL)
- (3) DISPLAY FORMAT (SPATIAL/VERBAL/NUMERIC)
- (4) PREDICTION OF COMPLEX TASK PERFORMANCE
- (5) SUBJECTIVE ASSESSMENT OF NON-HOMOGENEOUS INTERVALS
- (6) IMMEDIATE vs RETROSPECTIVE WORKLOAD EVALUATION
- (7) ASSOCIATION AMONG MEASURES OF WORKLOAD AND PERFORMANCE
- (8) BASIS OF SPACE SUIT EVALUATION TEST BATTERY
- (9) PRIMARY TASK FOR CURSOR CONTROL EVALUATION IN SHUTTLE

The "Fittsberg task" is a simple, flexible laboratory task where subtask workload levels can be independently manipulated and measured over a wide range. It provides an alternative to the traditional dual task paradigm in which two unrelated tasks are performed during the same time interval. It represents the types of tasks that are performed in many automated systems: a requirement for action is recognized and the appropriate plan of action selected. The plan of action is executed by an automated system in response to a discrete command.

"FITTSBERG" TASK

A TARGET ACQUISITION TASK (DIFFICULTY INDEXED BY FITTS LAW)

COUPLED WITH A BINARY DECISION BETWEEN RIGHT OR LEFT
(DIFFICULTY DETERMINED BY INFORMATION PROCESSING DEMANDS
OF RESPONSE SELECTION)

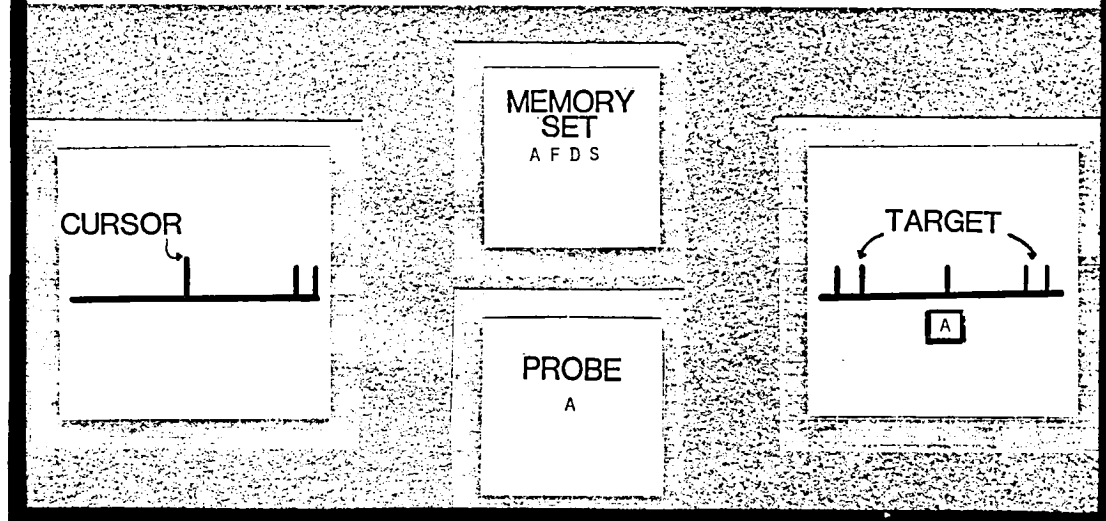

Fittsberg task components are functionally related - response selection provides information for and initiates response execution. The response selection task is a target acquisition based on Fitts' Law. Two identical targets are displayed equidistant from a centered probe. The decision about which target to acquire is based on a Sternberg memory search task; Subjects acquire the target on the right if the information presented in the center of the display is the same as a remembered value or the target on the left if it is not. A wide variety of response selection tasks have been used in addition to the Sternberg Task - - mental arithmetic, pattern match, time estimation, etc. Workload levels of one or both task components can be held constant or systematically varied within a block of trials. The stimulus modality of the two components can be the same (visual/visual) or different (auditory/visual).

Response selection performance is measured by RT and percent correct. Response execution performance is measured by MT. RT, but not MT, increases as the difficulty of the response selection task is increased. MT, but not RT, increases as target acquisition difficulty is increased. Workload ratings for the Fittsberg task integrate the influences of the component subtask components. Workload ratings and performance levels for the combined task are often substantially less than would be predicted by simply adding single-task workload ratings or response times .



Ames Research Center

WORKLOAD MEASUREMENT FOR SPACE SUIT DESIGN

WORKLOAD #04
PERFORMANCE
RESEARCH GROUP

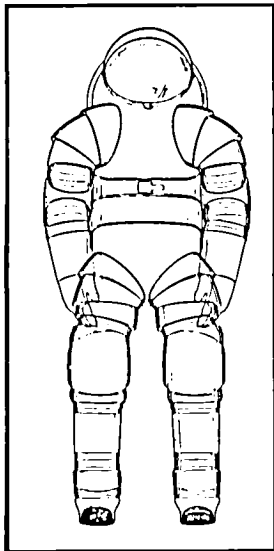

OBJECTIVE:
TO COMPARE ALTERNATIVE SPACE SUIT DESIGNS
FOR UPPER BODY MOBILITY AND COMFORT

APPROACH:
PERFORM TASKS THAT IMPOSE PREDICTABLE
DECISION-MAKING AND RESPONSE EXECUTION
WORKLOAD LEVELS BEFORE AND AFTER EXERCISE

EXPERIMENTAL TASKS:

EXERCISES:

TORQUE WRENCH
BICYCLE EGOMETER
WEIGHT TRANSFER
ROPE PULL

DECISION TASKS:

RIGHT/LEFT CHOICE
SHORT-TERM MEMORY
MENTAL ARITHMETIC

RESPONSE EXECUTION:

CONTROL STICK DEFLECTION
TARGET DIFFICULTY

MEASURES:

PHYSIOLOGICAL:

HEART RATE
OXYGEN UPTAKE

SUBJECTIVE OPINION:

COMFORT SCALE

MULTI-DIMENSIONAL WORKLOAD RATINGS

PERFORMANCE:

TASKS COMPLETED
REACTION TIME

% CORRECT
MOVEMENT TIME

This task has proven to be a useful focal point for several space-related applications. In response to a request by Johnson Space Center, we provided the hardware and software to use the Fittsberg task in a series of experiments in which two alternative space suit configurations were compared with respect to upper body mobility and comfort. Several Fittsberg tasks are performed using either fine or gross arm movements before and after a battery of physical exercises are completed. Physiological, subjective and performance measures are obtained to aid in the comparison between the two suit configurations.

Again the advantage of using this task is the fact that it has been calibrated in advance of the experiment with respect to expected workload and performance levels.

NASA-AMES WORKLOAD AND PERFORMANCE RESEARCH
STUDY OF CURSOR CONTROL DEVICES IN ZERO-G

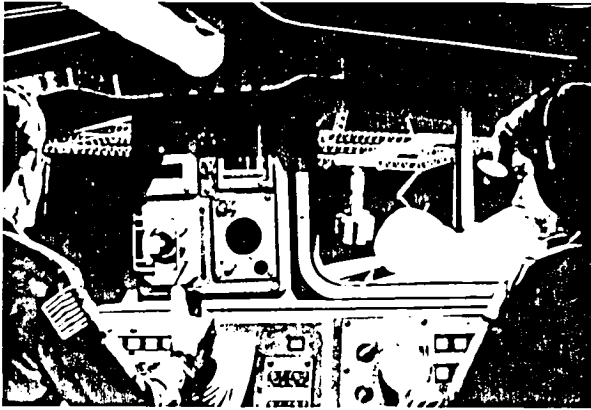

OBJECTIVE

- EVALUATE 3 CURSOR CONTROL DEVICES EARLY AND LATE IN ZERO-G EXPOSURE DURING FY86 SHUTTLE MISSION

APPROACH

- ARC/UNIVERSITY COLLABORATION
- ARC-DEVELOPED "FITTSBERG" TASK AS CRITERION TASK
- COMPARISON OF VERTICAL, HORIZONTAL, AND ANGULAR MOVEMENTS TO ACQUIRE TARGETS WITH:
 - TRACK BALL
 - JOYSTICK
 - ARROW KEYS

The Fittsberg task was selected for an experiment that will be flown in the Shuttle in the fall of 1986. The purpose of the experiment, which will be conducted jointly with MIT and JSC, is to evaluate three alternative cursor control devices in zero-G.

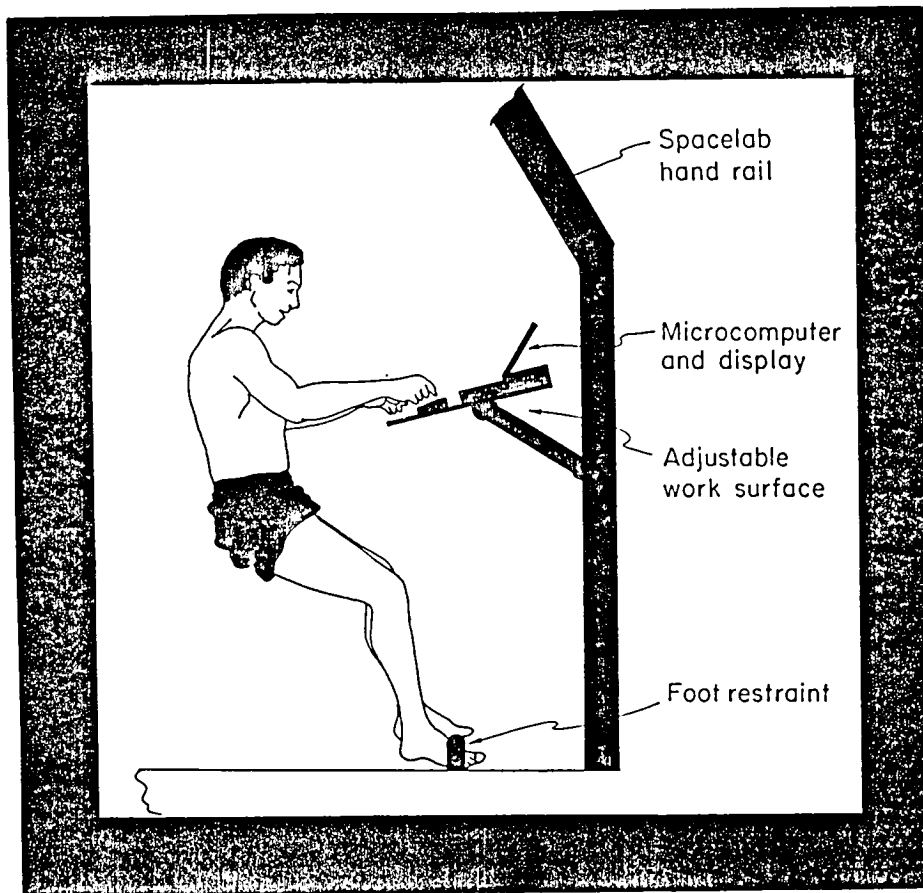

The experimental task will be presented on a Compass-Grid microprocessor mounted on an adjustable work surface attached to a Spacelab hand rail. Both foot and arm restraints will be provided. The three spaced input devices - - track ball, arrow keys, and joystick will be positioned with Velcro strips.

DISPLAY CONFIGURATIONS FOR CURSOR CONTROL EXPERIMENT
Memory Set = A

CARDINAL CONFIGURATION
Example: 'Easy' Target

DIAGONAL CONFIGURATION
Example: 'Hard' Target

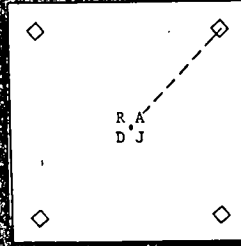
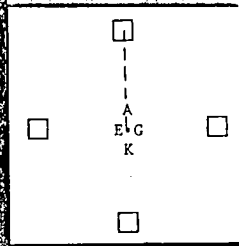

EXPERIMENTAL DESIGN:

Each block of 8 trials will be repeated three times (early, middle, and late in the mission) by four crewmembers.

	Cardinal Movements				Diagonal Movements			
	EASY ID		HARD ID		EASY ID		HARD ID	
	MS=1	MS=4	MS=1	MS=4	MS=1	MS=4	MS=1	MS=4
Keyboard								
Trackball								
Joystick								

Twenty-four blocks of Fitts trials will be performed during three, 30-min intervals early, middle, and late in the 7-day mission by four mission specialists. The difficulty of the response selection task will be manipulated by varying the number of items to be remembered (the Sternberg paradigm). The difficulty of the response execution portion of the task will be varied by manipulating the direction of movement - - either in a cardinal direction (up/down/right/left) or at an angle - - and by varying the index of difficulty of the target (target size and distance).

CRITERION TASK: POPCORN

OBJECTIVE: SIMULATE SUPERVISORY CONTROL ENVIRONMENT IN WHICH MULTIPLE, CONCURRENT TASKS ARE ACCOMPLISHED WITH AUTOMATIC SUBSYSTEMS

APPLICATIONS:

- o STUDY TIME-PRESSURE ASPECTS OF WORKLOAD
- o COMPARE WORKLOAD PREDICTIONS TO ASSESSMENTS
- o PROVIDE DATA BASE FOR MODELS OF HUMAN PERFORMANCE
- o EXAMINE INDIVIDUAL DIFFERENCES (E.G., TYPE A vs TYPE B)
- o COGNITIVE TEST USED BY USAF IN RETURNING PILOTS TO FLIGHT STATUS

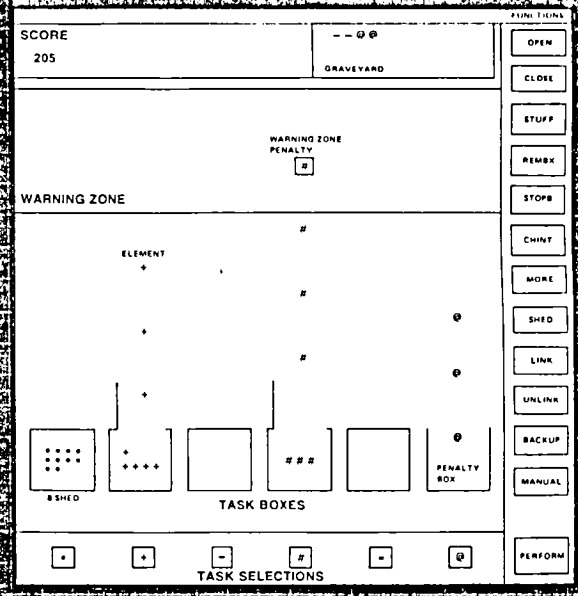

A second example of a criterion task developed at Ames is POPCORN, a dynamic, multi-task, supervisory control simulation. It represents operational environments in which decision-makers are responsible for actuating semi-automatic systems according to both pre-programmed and flexible schedules. Its name, POPCORN, reflects the appearance of groups of task elements waiting to be performed (they move around in a confined area and "pop" out when selected for performance).

Operators decide which tasks to do and which procedures to follow based on their assessment of the current and projected situation, the urgency of specific tasks, and the reward or penalty for procrastination or failure to complete them. Simulated control functions provide alternative solutions to different circumstances. Control may be accomplished by magnetic pen and pad entry, mouse input, or a VOTAN voice recognition system.

The most compelling feature of the POPCORN task is the wide variety of time pressure sources that can be generated, the time management strategies that are available, and the penalties imposed for procrastination.

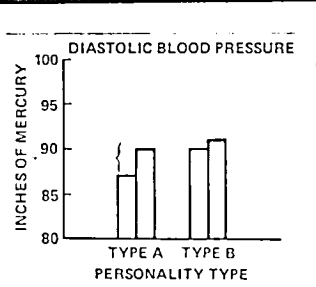
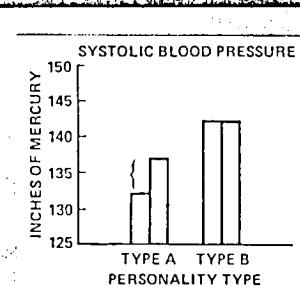
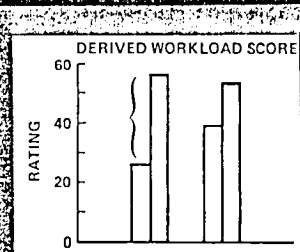
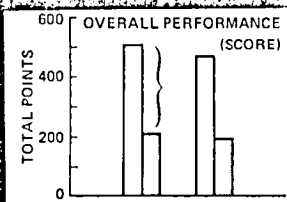

EXPERIMENTAL TASK
 [White Box] EASIEST SCENARIO
 [Black Box] HARDEST SCENARIO

OBJECTIVE
 PROVIDE EMPIRICAL VALIDATION OF HYPOTHESIS THAT "TYPE A" INDIVIDUALS ARE MORE REACTIVE TO TASK-INDUCED STRESSORS

APPROACH
 MEASURE HEART RATE, BLOOD PRESSURE SUBJECTIVE RATINGS STRATEGY SHIFTS AND PERFORMANCE IN RESPONSE TO EXPERIMENTAL MANIPULATIONS

RESULTS
 TYPE A MEN ARE SIGNIFICANTLY MORE REACTIVE, PHYSIOLOGICALLY, SUBJECTIVELY, AND BEHAVIORALLY, THAN TYPE B MEN

A recent experiment conducted jointly with SRI is one example of the applications in which POPCORN has been used. The objective was to provide empirical validation of the hypothesis that "Type A" individuals are more physiologically, behaviorally, and psychologically reactive to task-induced stressors than "Type B" individuals. It has been suggested that it is this differential level of reactivity that leads to the eventual development of cardiovascular disease associated with the "Type A" personality.

We found very strong empirical evidence that "Type A" men with normal resting blood pressure levels, are significantly more reactive to different levels of task-induced stress than otherwise similar "Type B" males. The results of this study have prompted researchers at Brooks AFB to adopt POPCORN as one of the battery of tests to be given when returning grounded pilots to flight status.

MEASUREMENT TECHNIQUES

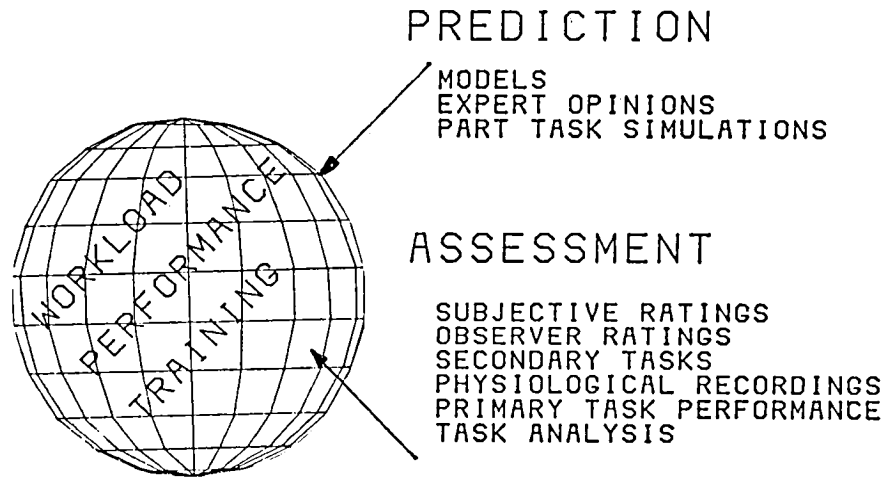

For the remainder of this talk I will describe typical predictive models and measures of workload that have been developed by this program and the methods used in validation.

ASSUMPTION 1: FOR WELL LEARNED TASKS,
FUNCTIONALLY INTEGRAL ACTIVITIES PROVIDE
THE NOMINAL LEVEL

NOMINAL DURATION
NOMINAL PERFORMANCE LEVELS
WORKLOAD EXPERIENCED

ASSUMPTION 2: ADDITIONAL TASKS, CHANGES IN THE
ENVIRONMENT, EQUIPMENT, OR PROCEDURES

IMPAIR WHOLE OR SUBTASK PERFORMANCE
REQUIRE ADDITIONAL TIME
INCREASE WORKLOAD

ASSUMPTION 3: THE INFLUENCE OF LIKELY OCCURRENCES
DURING DIFFERENT NOMINAL ACTIVITIES CAN BE
COMPUTED AND USED TO PREDICT NEW LOAD LEVELS

ASSUMPTION 4: THE RULES FOR COMBINING "EVENTS"
WITH NOMINAL ACTIVITIES TO CREATE DIFFERENT TASKS
MAY REFLECT:

TASK INTEGRATION
ADDITION
COMPETITION

During the past three years, we have developed a predictive model of pilot workload. The goal was to provide a standardized method of creating simulation scenarios to use in research. The initial focus of the model was on general aviation instrument flight (for convenience), although the model philosophy is being extended to helicopter operations and the space station. The goal was to provide a standardized format for creating simulation scenarios for workload and performance validation research, flight handling quality research, display and control evaluations and so on.

Workload prediction must, by necessity, focus on imposed task demands as a starting point. We assume, that for well-learned tasks, functionally integrated activities that are normally performed as a unit should provide the basic ingredients of the model. Rather than performing a fine-grained analysis of the components of highly overlearned tasks (which tends to overestimate the workload of experienced operators), we chose to focus on a level of analysis that most closely represents that used by expert performers when describing, performing and evaluating their actions.

The workload of these functional units - - such as specific phases of flight, sequences of control activities, etc - - is quantified and serves as the starting point for the model. Additional tasks, changes in the environment, equipment, procedures, or time available can be superimposed on these basic elements to modify the workload of the target scenario. The influence of these events can be computed as well, and the rules by which they combine with different nominal segments determined analytically, empirically and through expert opinions.

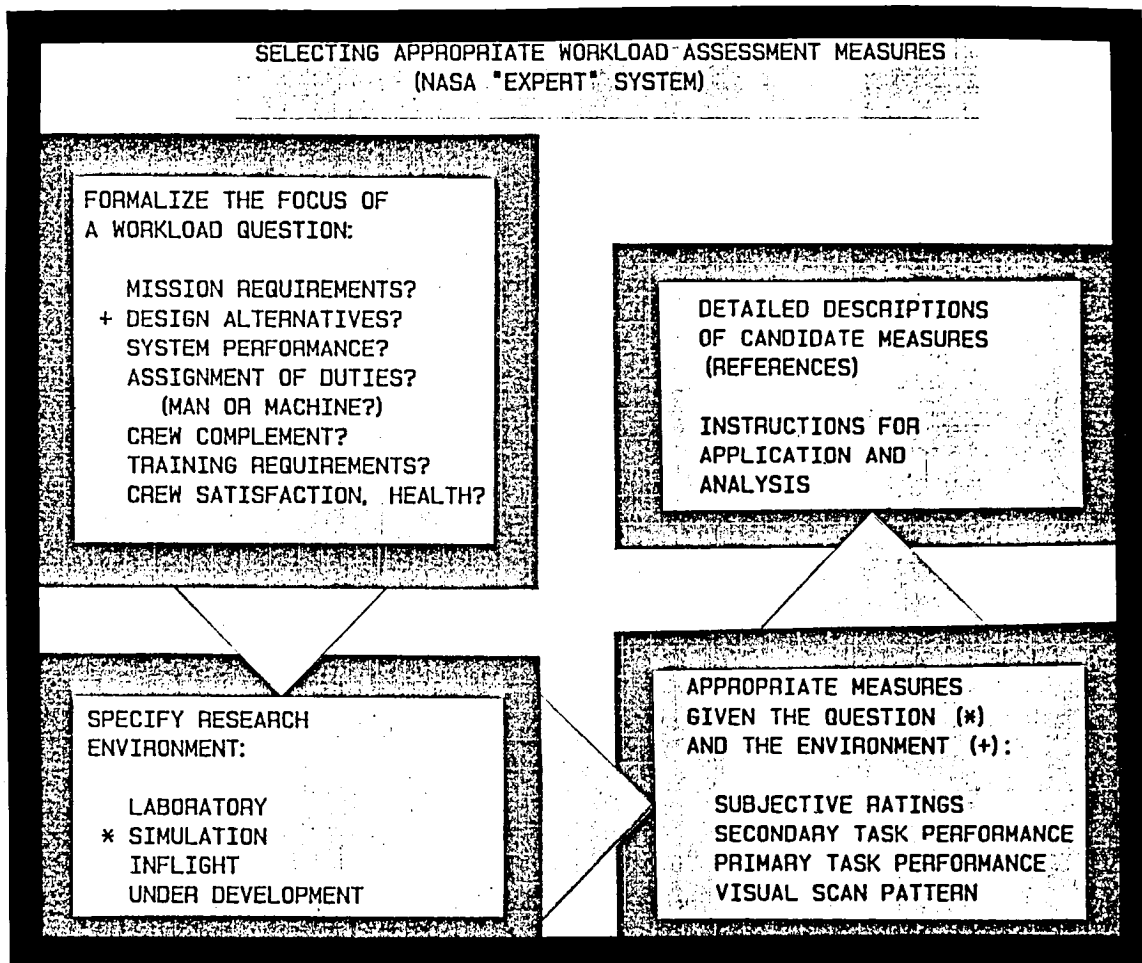

We are in the process of developing a simple "Expert" system for the selection and application of workload measures on an IBM-PC. The goal is to provide an interactive system whereby an individual who is not familiar with workload assessment, but needs to obtain information about the workload of a particular task or alternative pieces of equipment, can select and apply an appropriate measure. This system will serve to summarize and allow practical application of the results of our research.

This system will assist the user in formulating the question to be addressed and to specify the research environment. Appropriate measures will be suggested and evaluated. Detailed descriptions about how to apply the measure will be provided along with examples and references. The system will be a stand-alone, user-friendly, and provide easily accessible information. The first application will be as a hands-on component of the Army MANPRINT course.

As long as the human remains an integral element of complex, advanced systems, the need for standardized measures and predictors of human workload and performance will be required. The need for such tools is obvious both during the design and construction of the space station. Although the environment and activities to be accomplished in the space station are unique, the fundamental principles of human behavior and experience remain the same, and we are confident that the concepts and techniques that we have developed will provide a useful and informative tool for the development and operation of the space station.

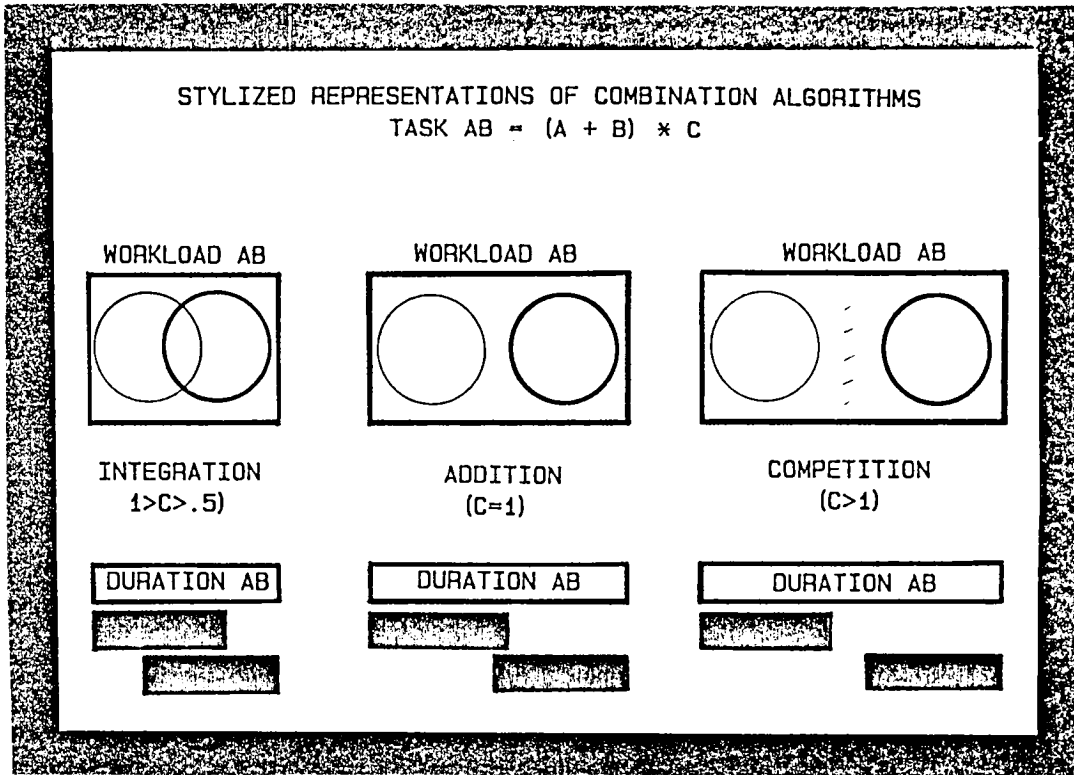

Through extensive research, we have identified a continuum of task combination rules that range from:

- (1) **INTEGRATION:** The workload or time required to perform concurrent tasks approximates that of the more demanding of the components
- (2) **ADDITION:** The workload or time required for a complex task is equal to the sum of the components
- (3) **COMPETITION:** Task components compete for operator's attention and "resources" and cannot be performed within the same time interval. There is an additional cost for switching among them and the cost of performing both tasks is greater than the sum of the parts.

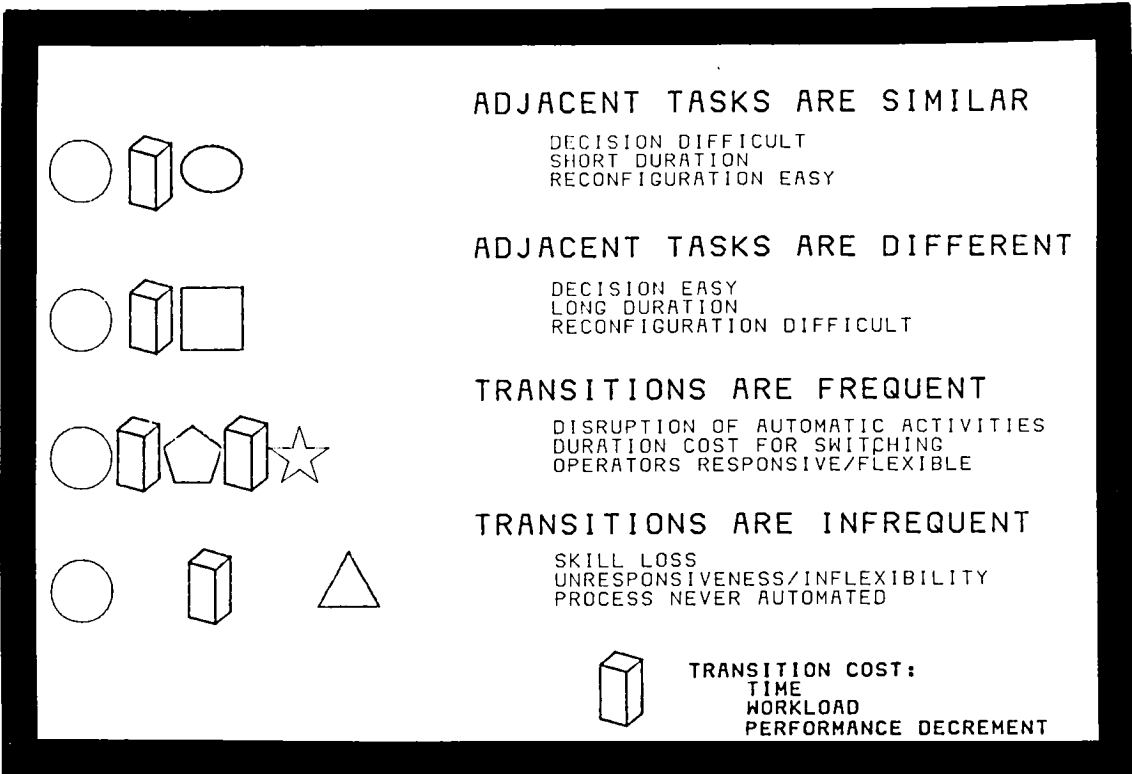

In addition to the basic workload associated with task segments and additional events, there may be brief periods of relatively high workload associated with the transition from one task segment to another. If the successive tasks are similar or frequently occur together, the transitions may occur quickly and with low workload. If they are not, the transitions may be time-consuming and demanding. In addition the sheer number of transitions that occur during a duty period may lead to high workload levels

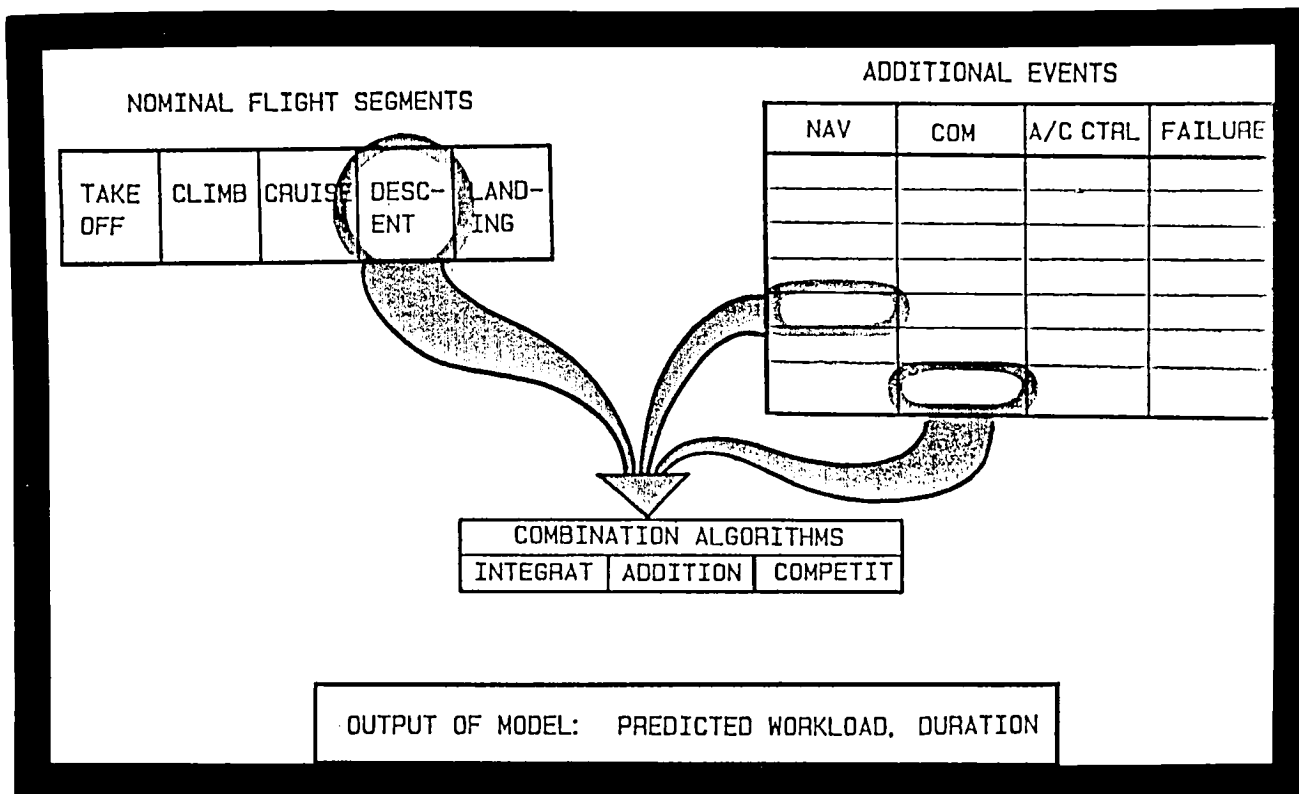

For each of the operational tasks to which this model is extended, a vehicle-specific data base is required, although the philosophy and structure of the model may be transferred. These nominal elements and additional events are entered into the computer data base and combined according to the appropriate algorithms dynamically by a researcher who wishes to create a simulation scenario of a specific duration, type, and workload level. The user may add and delete tasks until the predicted workload profile approximates the desired levels of imposed workload. The output of the model is a graphic representation of the predicted workload levels across time and a printed script to follow in conducting the simulation or operational test.

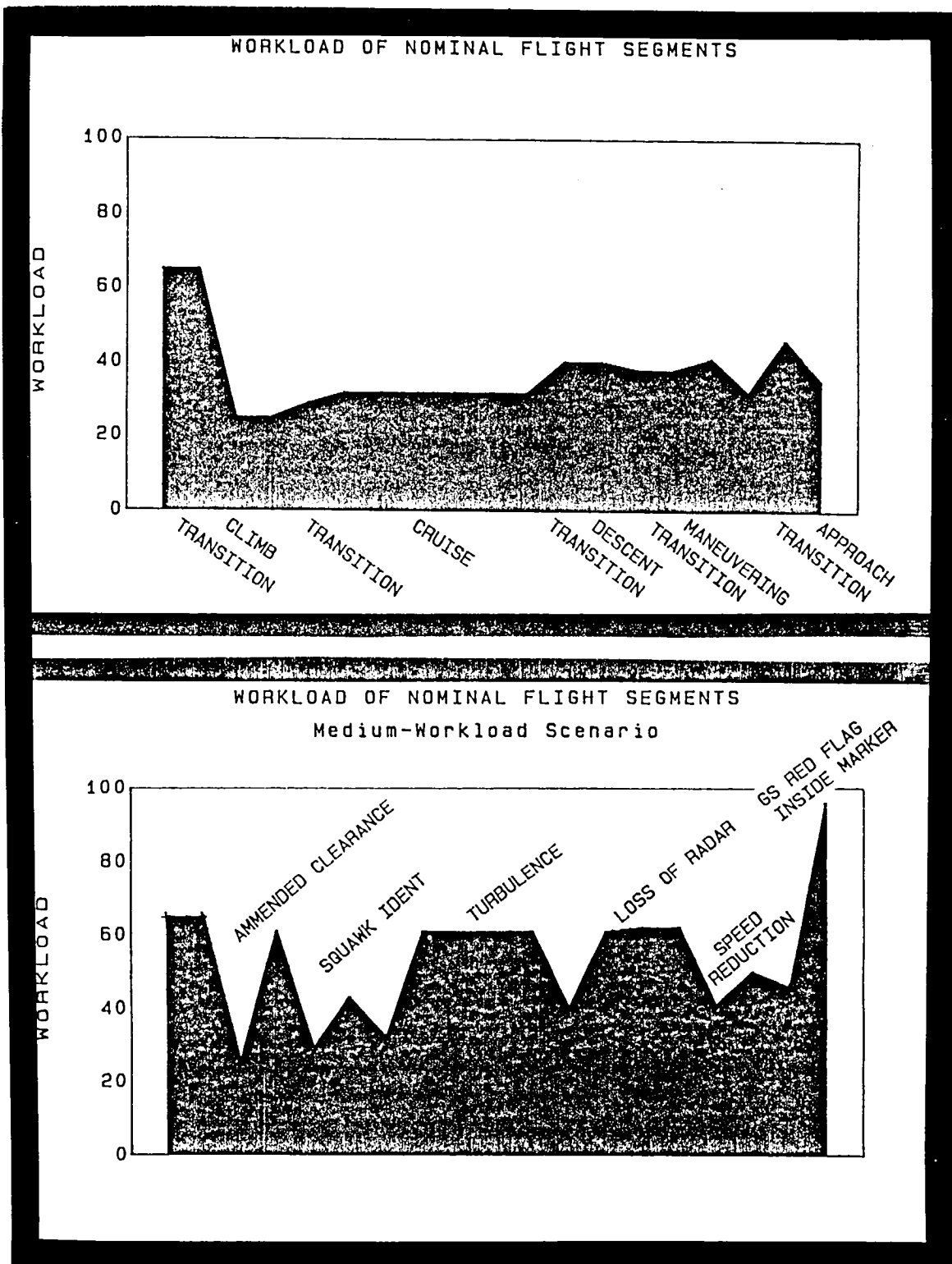

The following graphs represent one such nominal and modified scenario developed for instrument flight for a general aviation aircraft.

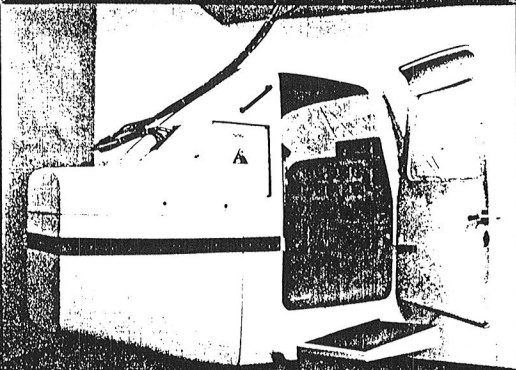

WORKLOAD PREDICTION

- * OBJECTIVE
 - DEVELOP PREDICTIVE MODEL FOR CONSTRUCTING STANDARDIZED SIMULATION SCENARIOS
- * APPROACH
 - CONDUCT PILOT OPINION SURVEY
 - DEVELOP PREDICTIVE MODEL
 - TEST MODEL PREDICTIONS IN GA SIMULATOR
- * RESULTS:
 - OBJECTIVE AND SUBJECTIVE MEASURES OF PILOT WORKLOAD CLOSELY MATCH MODEL PREDICTI
- * OPERATIONAL APPLICATIONS
 - HELICOPTER NOE FLIGHT
 - TRANSPORT OPERATIONS
 - SHUTTLE REMOTE MANIPULATOR A

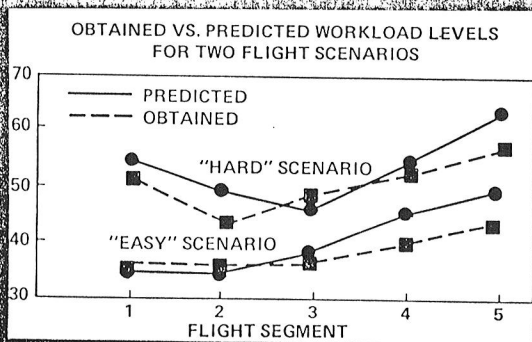

The predictions of the model have been validated in a series of simulation experiments. A battery of converging workload assessment measures are imposed to test the predictions of the model.

The first operational application of the model will be for advanced helicopter missions. Subsequent applications will focus on the space station as part of a Focused Technology Work Integration effort we will perform jointly with JSC.

WORKLOAD PREDICTION FOR SHUTTLE RMS OPERATIONS

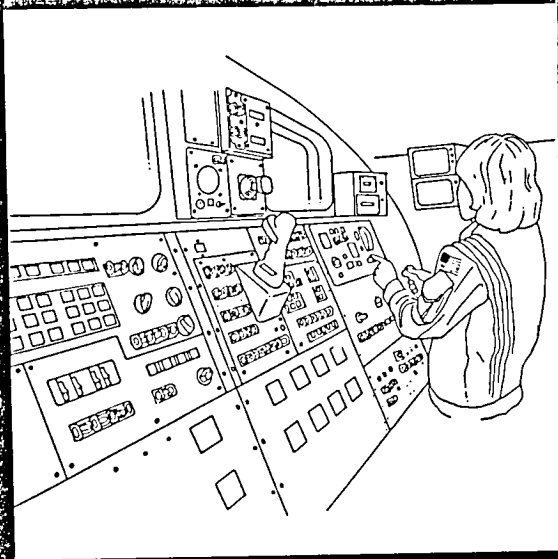

OBJECTIVE

- PREDICTION OF WORKLOAD ASSOCIATED WITH OPERATOR CONTROL OF REMOTE MANIPULATOR ARM
- ASSESSMENT OF ACTUAL WORKLOAD UNDER IG SIMULATED OPERATION

APPROACH

- COLLABORATIVE ARC/JSC ACTIVITY
- FORMAL TASK DESCRIPTION
- ANALYTIC TASK REPRESENTATION USING AMES MODEL
- PART TASK TEST OF MODEL AT ARC
- SIMULATOR VALIDATION IN RMA SIMULATOR AT JSC

PAYOFF

- GROUND VALIDATED WORKLOAD PREDICTION AND ASSESSMENT FOR RMA TASKS
- COMPARATIVE, QUANTITATIVE ANALYSES OF NEW RMA OPERATOR INTERFACE TECHNOLOGY (e.g. VOICE)

The objective of this task is to develop and test a workload model for evaluation and prediction of a Space Station human operated system. The system selected as the first test of the model is the Remote Manipulator Arm. The initial focus will be on the existing RMS used in the shuttle, although space-station specific modifications will be incorporated as they are specified.

A functional task analysis will be provided by JSC. It will be used as the initial data base for the prediction model. Using analytic, part-task simulation, and expert opinion approaches, the appropriate workload levels and combination rules will be determined.

An initial test of the model will be performed at Ames, in the proximity operations mockup. A simulator evaluation will be performed at Johnson Space Center in the RMS simulator during the second year of the project. This model will be used to predict the workload of alternative configurations and advanced RMS technology from the perspective of the human operator. Future applications might be to provide workload estimates as a feature in the existing OPSIM model developed at Ames.

The expected product of this effort is a ground-validated workload and performance model that is suitable for use by contractors and Levels B and C personnel for the prediction and evaluation of workload and performance-effectiveness of human-operated Space Station systems.

MEASUREMENT TECHNIQUES

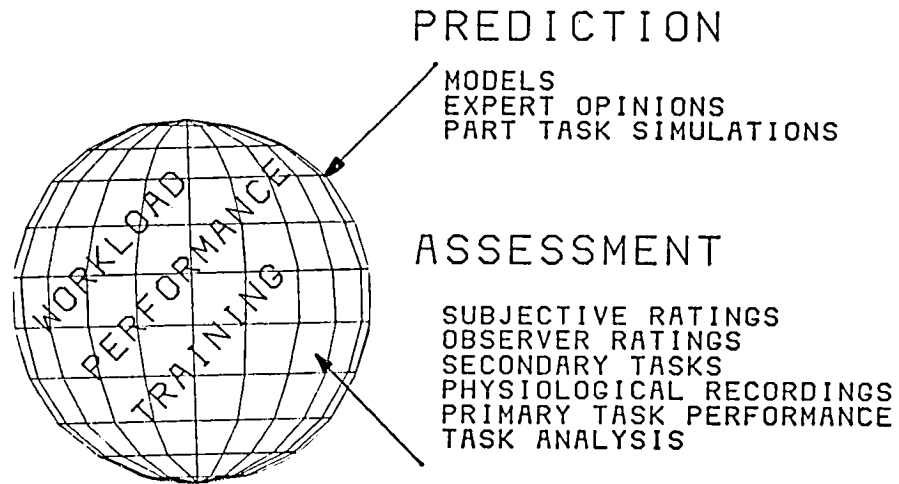

The primary focus of this program has been the development and validation of a battery of workload and performance assessment tools that reflect sound theoretical models of human operator performance and information processing. We examined existing techniques and developed additional ones to meet the needs of a wide variety of operational environments. Our goal was to provide sensitive and reliable tools and to disseminate information about them to make the results of our research widely available and practically useful.

For each of three categories of measures - - performance, physiological, and subjective - - I will describe a typical technique and describe how it was developed and validated.

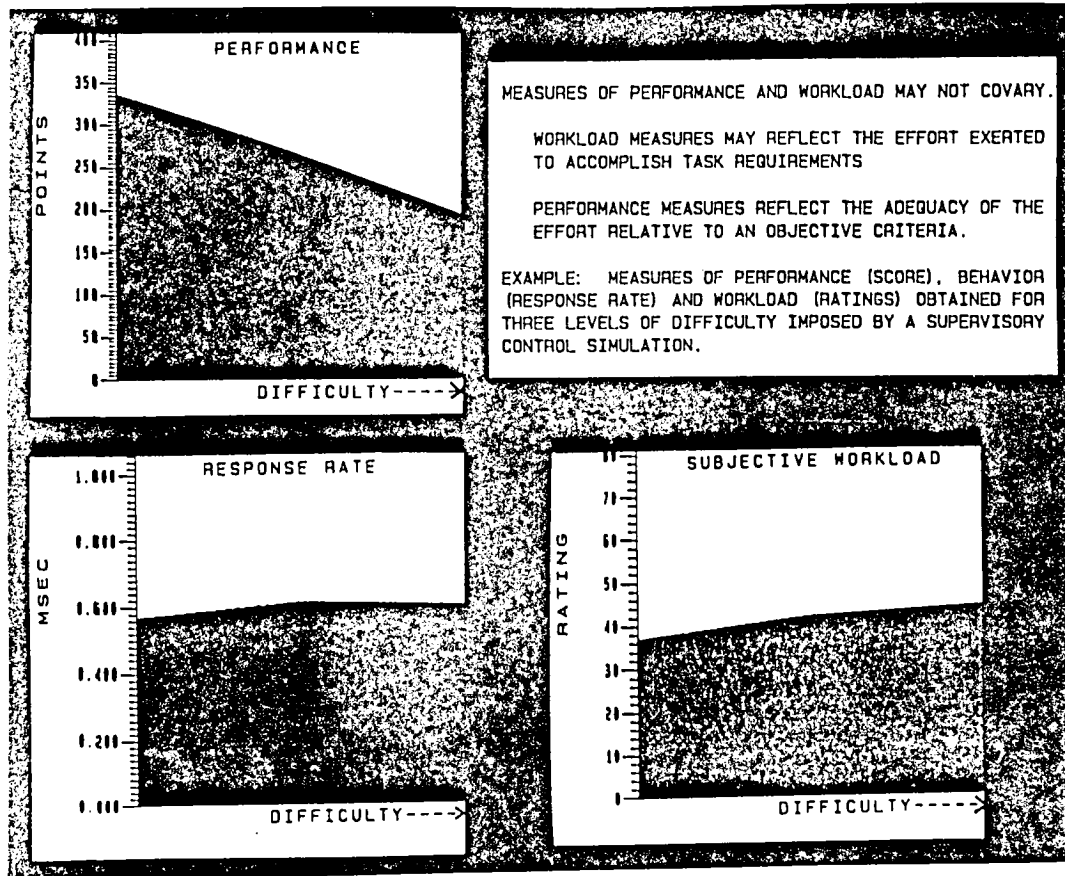

Early in the program, it became clear that, although human and system performance provided the most common motivation for workload analyses, performance measures themselves do not always reflect variations in operator workload. Within the range of their capabilities, skilled, motivated operators exert increasing levels of effort to accomplish increasing task demands. Performance degradation often occurs only after their capabilities are exceeded, or when they choose to maintain a consistent level of effort in the face of increased task demands. Subjective secondary, and physiological indicators of workload are more reflective of the cost of performance to the operator in such cases, and are able to quantify how much reserve capacity an operator still has when performing the task of interest. In addition, workload measures are able to predict future performance - - should task demands be increased yet farther - - while measures of performance are not.

One example of a dissociation between measures of workload and performance is represented by a recent study completed with the POPCORN simulation. As time pressure was increased, performance (as measured by the subject's score) dropped, as predicted. Workload levels remained constant however. They reflected the fact that operators maintained a consistent response rate in the face of increased tasks demands, and thus the cost of task performance - - at least as far as the operators were concerned - - remained constant.

PRIMARY TASK PERFORMANCE:
FREQUENCY OF COMMUNICATIONS

OBJECTIVE:

EVALUATE SENSITIVITY OF DIFFERENT
MEASURES TO NORMAL WORKLOAD
VARIATIONS IN FLIGHT

APPROACH:

OBTAIN DIFFERENT MEASURES DURING
11 ROUTINE MISSIONS OF THE NASA
KUIPER AIRBORNE OBSERVATORY (C-141)

RESULTS:

RATED WORKLOAD AND COMMUNICATIONS
FREQUENCIES VARIED SIGNIFICANTLY
ACROSS FLIGHT SEGMENTS

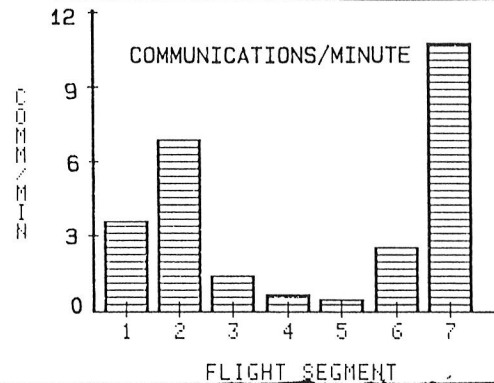
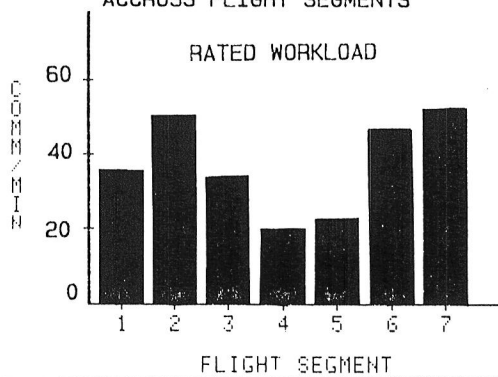
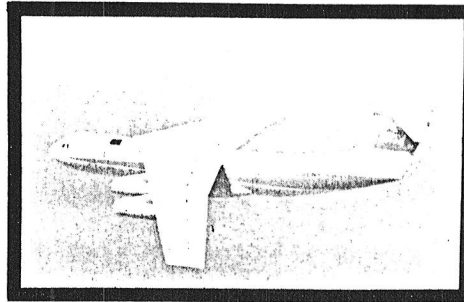

Selected measures of performance may covary with operator workload. In a study that we conducted in the Kuiper Airborne Observatory, we found that the rate of communications activities provided a convenient and sensitive measure of the overall levels of workload imposed on the flight crewmembers.

In addition, we have found that specific types of communications are associated with different levels of workload. A post hoc communications analysis can provide a sensitive workload evaluation in a many of environments, using data that is readily available in most operational environments.

COMMUNICATIONS ANALYSIS: MEASURES OF CREW COORDINATION
AND DECISION MAKING

OBJECTIVE:

ANALYZE FLIGHT DECK AND ATC COMMUNICATIONS TO ASSESS AIRCREW DYNAMICS
COMMUNICATIONS COMPETENCY, AND AIRCRAFT MANAGEMENT

APPROACH:

- o CONDUCT SIMULATIONS IN B-707
SIMULATOR
- o OBTAIN POST-FLIGHT EVALUATIONS BY:
 - (1) CREWMEMBERS
 - (2) EXPERTS IN LINGUISTIC
AND SEMANTIC ANALYSIS
 - (3) EXPERTS IN FLIGHT SAFETY

RESULTS:

- o CREWS DIFFERED IN COMMUNICATIONS
COMPETENCY AND LEADERSHIP ROLES
- o CREW COORDINATION AFFECTED DECISION
MAKING AND AIRCRAFT MANAGEMENT

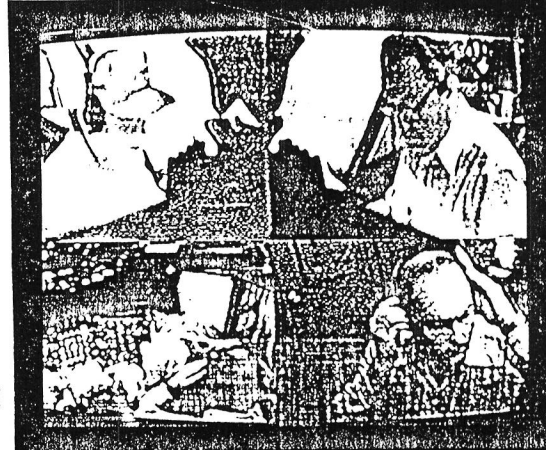

Another facet of communications that we have investigated is the role of flight deck communications in aircrew organization and coordination. In a recent simulation of transport operations, we found that crews differed in communications competency. Communications analyses provided a sensitive measure of leadership and crew coordination - - factors that play important roles in the safety and efficiency of aircrew performance. Crew coordination affected decision making behavior and aircraft management.

The primary goal of this part of the program is to develop a training program to improve crew communications competency, coordination and leadership.

PHYSIOLOGICAL MEASURES:
EXAMPLES

- o MEASURES OF MENTAL AND PERCEPTUAL PROCESSING
 - * EVOKED CORTICAL POTENTIALS
 - * EYE POINT OF REGARD

- o MEASURES OF EMOTIONAL AND PHYSICAL ACTIVATION
 - * HEART RATE AND VARIABILITY
 - * BLOOD PRESSURE
 - * GALVANIC SKIN RESPONSE
 - * RESPIRATION RATE
 - * MUSCLE TENSION
 - * VOCAL STRESS
 - * PUPIL SIZE

We have investigated a number of physiological measures of workload. Several measures provide relatively specific indicators of mental and perceptual processing - - such as auditory evoked cortical potentials. In addition, we have examined a number of measures that reflect more general levels of activation, such as heart rate, and pupil size. The advantage of physiological measures is that they are unobtrusive, do not interfere with primary task performance, and they provide common, objective measures across a variety of tasks.

NASA C-141 WORKLOAD STUDY

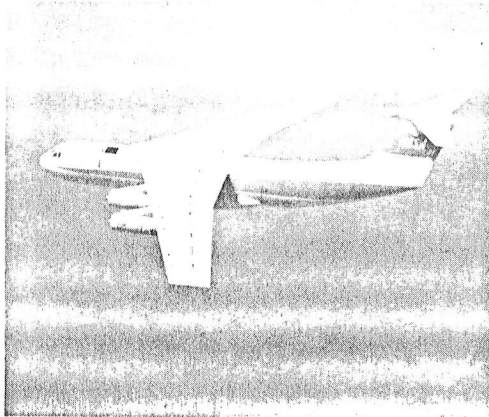

HEARTRATE:

- REFLECTS STRESS, NOT BUSYNESS
- IS MORE SENSITIVE TO STRESS THAN SUBJECTIVE RATINGS

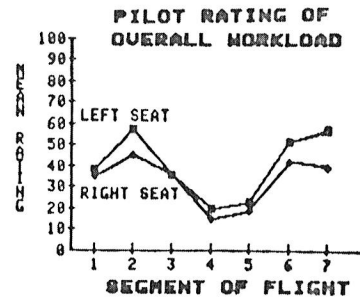
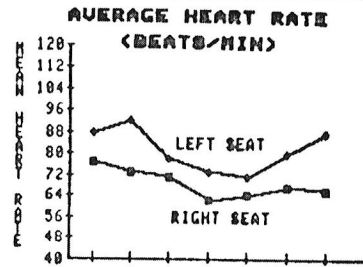

The research we have conducted in evaluating heart rate and heart rate variability is one example of this area of research. Heart rate provides a convenient and nonintrusive indicator of the overall level of activation of an operator. It is less likely to reflect more subtle changes in workload associated with different levels of mental activities, however. In the study that I mentioned earlier, we obtained measures of pilot heart rate during 11, eight-hour routine missions of the Kuiper Airborne Observatory using the portable Vitalog physiological recording unit.

The heart rate profiles of the pilot-flying, reflected the expected peaks during take-off and landing. The profiles of the pilots-not-flying reflected no significant changes, however. These results, in agreement with earlier studies, suggest that heart rate reflects responsibility and stress, rather than mental workload.

These data are particularly interesting because the test pilots who participated in the study were qualified in both positions, and the same pilots are represented in the data for both. The pilots experienced and reported apparently similar levels of subjective workload throughout the flight, but the heart rates suggested that there were differences in the physiological consequences of performing the duties required by the two positions.

In other studies, we have found that heart rate is quite insensitive to the variations in levels of workload imposed by a wide variety of laboratory tasks unless rather heavy physical effort is involved.

These data again point out the need for multiple, converging measures

of workload to obtain the most complete picture possible of the impact of performing a task on the operator.

We are focusing most of our research efforts in the area of heart rate variability. In particular, we have evaluated the power in the .1 Hz range of the frequency spectrum of the beat-to-beat intervals as a very promising measure. There is considerable evidence that this measure provides a sensitive indicator of different levels of mental workload. The typical finding is that heart rate variability (and the power in the .1 Hz region) decrease as mental workload is increased. A "black box" has been developed to obtain and process this measure automatically online.

SUBJECTIVE RATINGS:
ISSUES

- * PROVIDE SIGNIFICANT SOURCE OF INFORMATION
- * MAY TAP THE ESSENCE OF MENTAL WORKLOAD
- * REFLECT SUBSET OF INFORMATION AVAILABLE DURING TASK PERFORMANCE
 - RESULTS OF INFORMATION PROCESSING
 - MEMORIES
 - OVERT BEHAVIOR
 - FEELINGS
- * INDIVIDUAL DIFFERENCES IN DEFINITION AND EXPERIENCE
- * NO MENTAL REFERENCE SCALE FOR "WORKLOAD"
- * BEST TO COMPARE SHARED QUALITIES AND SIMILAR ACTIVITIES
- * CALIBRATION OF RATERS
- * TIMING
 - ON-LINE vs RETROSPECTIVE
 - PRIMACY/RECENCY OR ODDBALL EFFECTS
- * PSYCHOMETRIC CONSIDERATIONS
 - EQUALITY OF INTERVALS
 - NO "ZERO" POINT OR "MAXIMUM"

Considerable effort has been devoted to understanding and measuring the subjective workload experiences of operators, as this is the most convenient and practically useful measure. In addition, it is the measure against which most other measures are calibrated. We have found that subjective ratings provide a significant source of information, come closest to tapping the essence of mental workload, and provide the most direct indicator about the subjective impact of a task on operators.

People often generate evaluations about the workload of ongoing experience, however they rarely quantify or remember such experiences. Thus, experiencing workload is unique to experimental situations, although the requirement to verbalize, remember or quantify such experiences may not be a commonplace activity. The goal of our research has been to determine what factors influence such subjective experiences (and which ones do not) and to develop a valid, sensitive, and reliable measure of them.

THE TYPES OF EXPERIMENTAL TASKS INCLUDED IN THE WORKLOAD RATING SCALE
DEVELOPMENT EFFORT

- o SIMPLE, COGNITIVELY-LOADING TASKS
CHOICE REACTION TIME, MEMORY SEARCH, MENTAL ARITHMETIC,
MENTAL ROTATION, PATTERN MATCH
- o SIMPLE, MANUALLY-LOADING TASKS
ONE AND TWO AXIS TRACKING
- o CONCURRENT, INDEPENDENT DUAL-TASKS
TRACKING + MEMORY SEARCH, MENTAL ROTATION
- o SERIAL, INTEGRATED "FITTSBERG" TASKS
TARGET ACQUISITION + MEMORY SEARCH, MENTAL ARITHMETIC, RHYMING,
PATTERN MATCH, PREDICTION, TIME ESTIMATION
- o COMPLEX SUPERVISORY CONTROL SIMULATIONS ("POPCORN")
- o PART-TASK AND FULL-MISSION AIRCRAFT SIMULATIONS

During the past three years, we have conducted a series of 25 experiments in which a multi-dimensional battery of bipolar rating scales were presented to subjects following a variety of tasks. For 15 of these experiments, the ratings, and individual definitions of workload were combined into a data base and a number of global analyses were performed.

The objective was to determine:

- (1) What factors are sensitive to workload differences between different types of tasks
- (2) What factors are sensitive to workload differences within tasks
- (3) What factors are included in the workload definitions of most individuals
- (4) What is the appropriate scale format

The primary problems that we encountered in this effort were:

- (1) There is no objective standard against which workload ratings can be compared
- (2) The workload of a task is not uniquely defined by its objective demands but represents the behaviors and psychological responses of individual subjects as well
- (3) Different individuals may adopt different references activities and have different personal definitions of workload

We organized the experimental tasks into six categories. These tasks ranged from simple, cognitively loading tasks to complex aircraft simulations. Several thousand data points were included in each category.

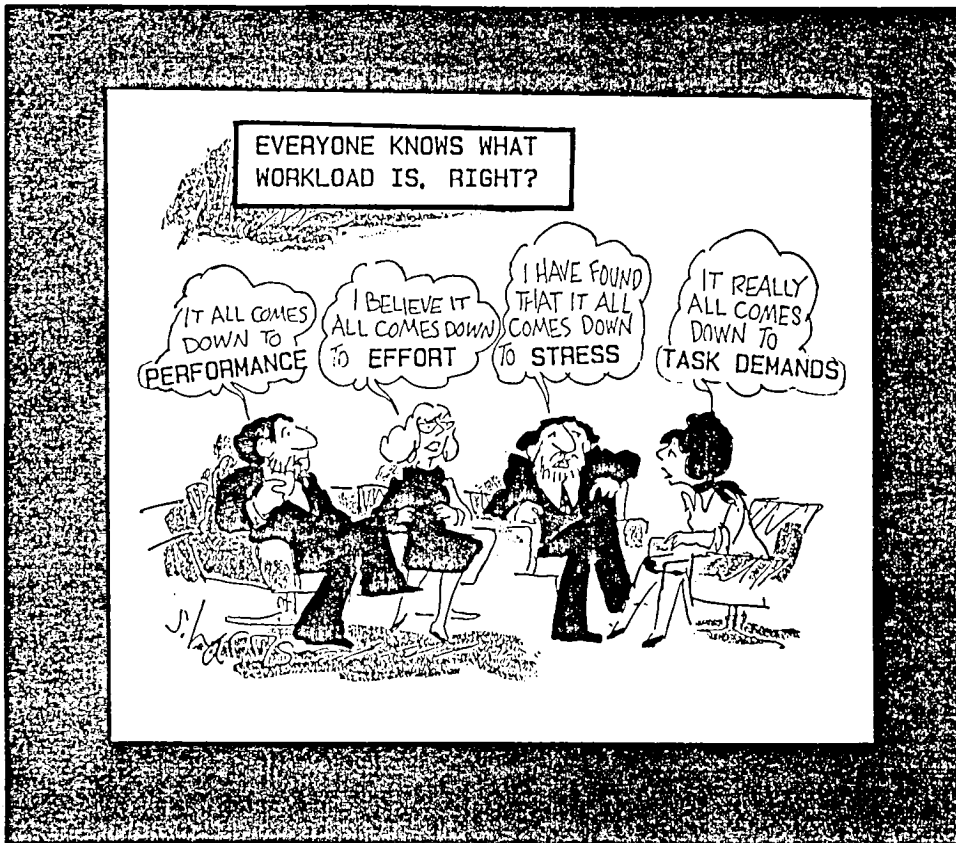

We found that different individuals consider different variables in formulating workload ratings. Thus, one person's overall workload rating might reflect the level of time pressure experienced while another's might reflect the level of cognitive effort exerted or their apparent failure to accomplish the task requirements. People are generally unaware of the fuzziness of their definitions, however, they are able to express their biases when asked to do so.

SUBJECTIVE RATINGS
METHOD FOR REDUCING THE
BETWEEN SUBJECT VARIABILITY

WORKLOAD DIMENSIONS:

- TASK DIFFICULTY
- TIME PRESSURE
- OWN PERFORMANCE
- PHYSICAL EFFORT
- MENTAL EFFORT
- STRESS
- FATIGUE
- FRUSTRATION
- TYPE OF TASK

BIPOLAR RATINGS:

THE AMOUNT OF EACH FACTOR EXPERIENCED IN A TASK IS EVALUATED ON A BIPOLAR SCALE:

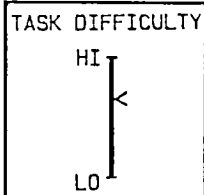

"WEIGHTS"

EACH OF 9 FACTORS IS COMPARED WITH EVERY OTHER ONE (WHICH IS MORE RELATED TO WORKLOAD?)

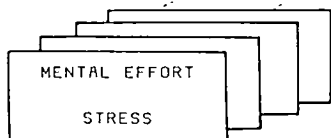

- 0 = NEVER SELECTED
- 8 = ALWAYS SELECTED

WEIGHTING PROCEDURE

EACH "RATING" IS WEIGHTED BY ITS SUBJECTIVE IMPORTANCE TO EACH SUBJECT (THE "WEIGHTS")

THE AVERAGE OF THE WEIGHTED RATINGS = DERIVED WORKLOAD SCORE

We found, that by weighting the bipolar ratings obtained on the component scales by the subjective importance of each factor to each subject, and by averaging these weighted ratings, we were able to obtain a significant reduction in between-subject variability in a summary estimate of overall workload.

These summary scores reflected the same workload levels indicated by overall workload ratings, but with a 25-50% reduction in variability. However, the sensitivity of the summary measure to experimental manipulations was not significantly enhanced.

SUBSCALES SELECTED FOR NASA WORKLOAD RATING SCALE

TASK RELATED:	o MENTAL DEMANDS	(MD)
	o PHYSICAL DEMANDS	(PD)
	o TEMPORAL DEMANDS	(TD)
RESPONSE-RELATED:	o EFFORT EXPENDED	(EF)
	o PERFORMANCE QUALITY	(OP)
	o FRUSTRATION LEVEL	(FR)

We found that at least six factors are necessary to discriminate between workload levels within and between tasks. They are:

Task related:

Temporal Demands, Physical Demands, and Mental Demands

Subject-related:

Own Performance, Frustration, and Effort.

Each of these scales alone provides useful, diagnostic, and often independent information about the sources of workload and the experiences of operators. By combining these individual scale values, weighted to reflect their importance in creating the level of workload imposed by a specific task, a global indicator of overall workload can be derived that is less variable between subjects and more sensitive to experimental manipulations than are existing rating techniques.

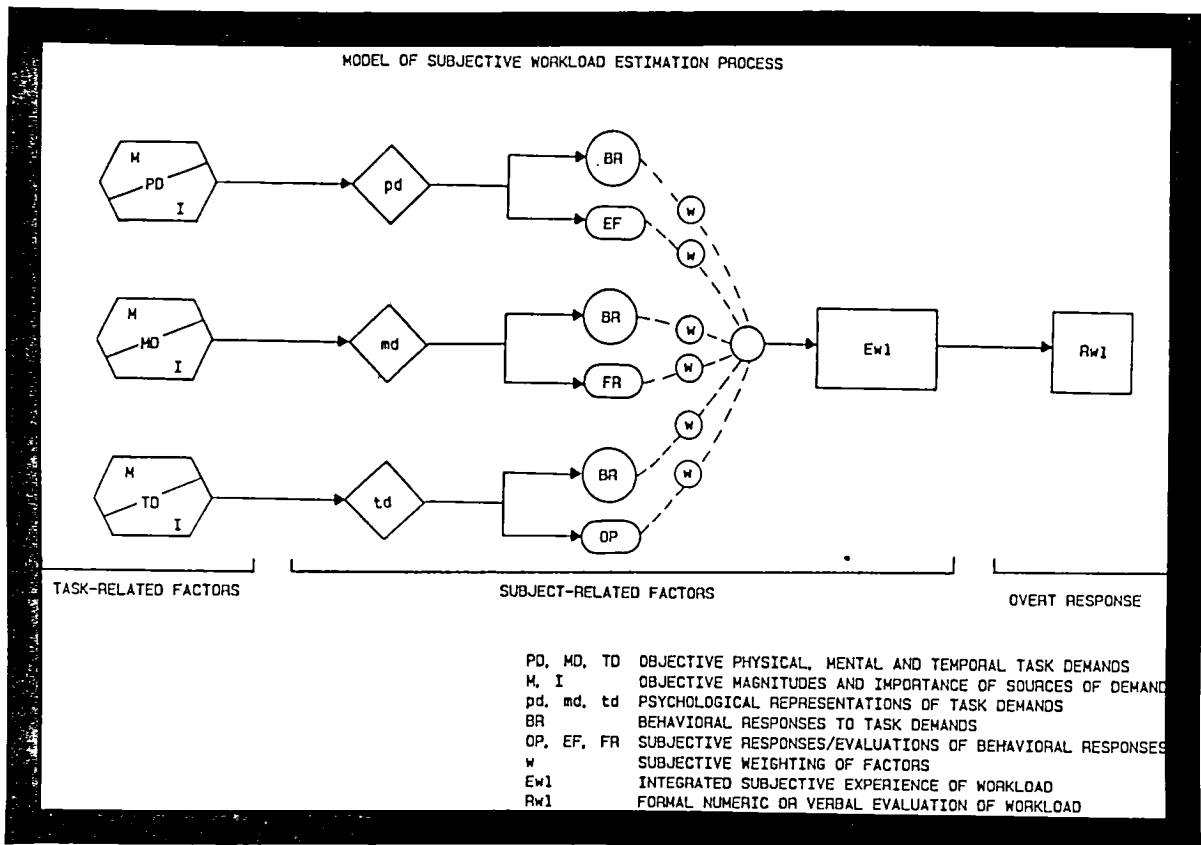

A priori workload weights, which form the basis for several popular techniques, do not reflect the objective contributions of specific factors to the workload of a specific task. The model presented in this figure represents the conceptual framework of the rating technique that we developed. Objective demands are imposed on an operator, which are translated into psychological representations. These invoke behavioral and psychological responses from an operator. A weighted combination of the relevant factors - - both objective and subjective - - are integrated into a subjective experience of workload that may be translated in to a numeric or verbal evaluation. The key element of this model is that the integration represents a weighted combination of factors. The weights reflect the objective and subjective importance of the factors to the structure of that task and the ratings reflect the psychological magnitudes of each factors during that activity.

The bipolar rating scale that we propose is two dimensional: evaluations of the magnitude as well as the importance of each of six factors are obtained from subjects following specific tasks or task segments. The combined weighted average of the six factors provides a sensitive and stable measure of overall workload.

PRELIMINARY VALIDATION
OF SELECTED WORKLOAD
ASSESSMENT TECHNIQUES

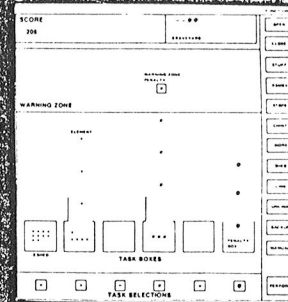

LABORATORY STUDIES (CRITERION TASKS)

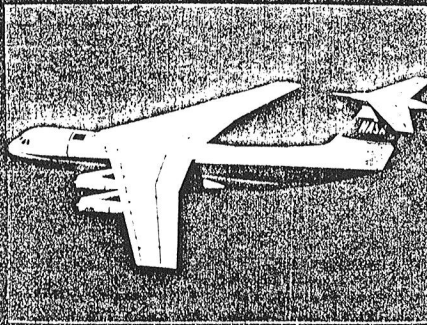

INFLIGHT (KUIPER AIRBORNE OBSERVATORY)

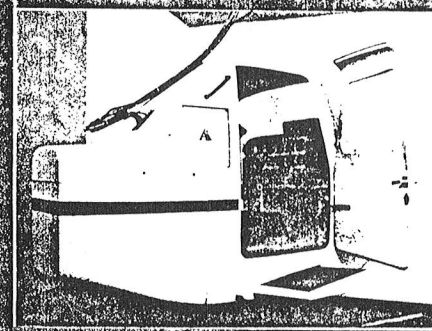

PART-TASK SIMULATION (GAT SIMULATOR)

With this measure, as with all of the others, validation is accomplished in a variety of environments. Each measure is tested against criterion tasks that impose known, well-controlled levels of workload. Promising measures are then tested in part-task simulations within our lab. Finally, many measures have been applied - - piggy-back - - on a variety of operational activities to provide "real-world" validation.

VALIDATION OF NASA WORKLOAD ASSESSMENT MEASUREMENT BATTERY

OBJECTIVE: DETERMINE THE SENSITIVITY AND OPERATIONAL VALIDITY OF THE WORKLOAD MEASURES DEVELOPED AT NASA-AMES

APPROACH: CONSTRUCT SCENARIOS WITH WORKLOAD PREDICTIVE MODEL
PERFORM FLIGHTS IN B-727 SIMULATOR AND SH-3 HELICOPTER
COMPARE MODEL PREDICTIONS TO EMPIRICAL RESULTS

MEASURES: PERFORMANCE (COMMUNICATIONS, ERRORS, CREW COORDINATION,
CONTROL VARIABILITY, SECONDARY TASKS)
PHYSIOLOGICAL (HEART RATE/VARIABILITY, EYE BLINK RATE/TIMING,
SCAN PATTERN, AUDITORY EVOKED CORTICAL POTENTIALS)
SUBJECTIVE (NASA MULTI-DIMENSIONAL SCALE, REFERENCE TASK
COMPARISON, MODIFIED COOPER-HARPER SCALE)

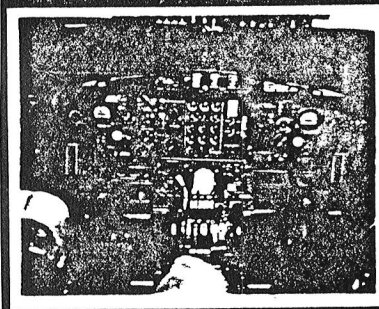

MVSRF 727 COCKPIT



SH-3 HELICOPTER

The final validation effort for our workload-assessment battery will be accomplished within the next year. We plan to conduct at least two full-mission studies in which all of the most promising measures will be applied in realistic environments. The test scenarios will be created with the workload predictive model. Two environments have been selected for these studies:

- (1) The MVSRF 727 motion-base simulator
- (2) A Sea-king (SH-2) helicopter.

Our goal is to provide as complete and as operationally relevant a validation of the measures as possible in a well-controlled and realistic series of flights.

Concurrent with this effort, the predictive model for Space Station application will continue, and it will be validated at JSC in 1987.

SPATIAL COGNITION

Mary Kister Kaiser
Roger Remington

NASA Ames Research Center

SPATIAL COGNITION is the ability to reason about geometric relationships in the real (or a metaphorical) world based on one or more internal representations of those relationships. The study of spatial cognition is concerned with the representation of spatial knowledge, and our ability to manipulate these representations to solve spatial problems. Spatial cognition is utilized most critically when direct perceptual cues are absent or impoverished.

Our presentation provides examples of how human spatial cognitive abilities impacts on three areas of space station operator performance: orientation, path planning, and data base management. A videotape provides demonstrations of relevant phenomena (e.g. the importance of orientation on recognition of complex, configural forms). The following readings are suggested as entries into the psychological literature on spatial cognition:

- Olson, D. R. & Bialystok, E. (1983). Spatial Cognition. Hillsdale, New Jersey: Lawrence Erlbaum Associates, Inc.
- Rock, I. (1984). Perception. New York: Scientific American Books, Inc.
- Shepard, R. N. & Cooper, L. A. (1982). Mental Images and their Transformations. Cambridge, MA: The MIT Press.

AREAS IN WHICH SPATIAL COGNITION IMPACTS PERFORMANCE:

- * ORIENTATION

- * PATH PLANNING

- * DATA BASE MANAGEMENT

SPECIAL CONCERNS OF SPACE STATION

- * ABSENCE OF VESTIBULAR CUES
- * MULTIPLE FRAMES OF REFERENCE
- * ADDITIONAL DEGREES OF FREEDOM
- * COMPLEX, NON-INTUITIVE DYNAMICS

ORIENTATION ONBOARD THE SPACE STATION: A CHALLENGE TO SPATIAL COGNITION

80

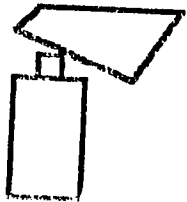

FREE FLYER VERTICAL

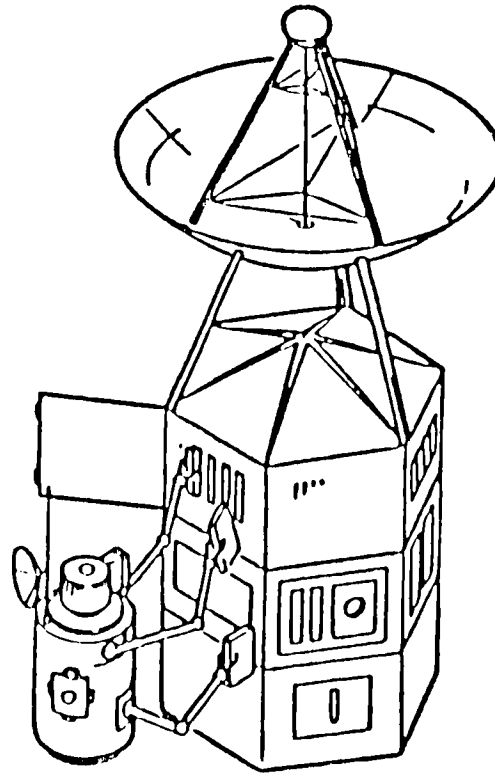

TELEOPERATOR VERTICAL

SATELLITE VERTICAL

MULTIPLE CAMERA ANGLES
(POINTS-OF-VIEW)

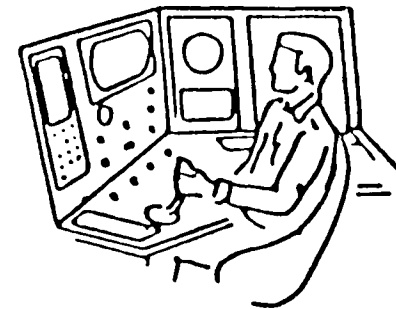

STATION LOCAL VERTICAL

EARTH-DOWN VERTICAL

SPATIAL TRANSFORMATIONS INVOLVE TIME-DEPENDENT MENTAL OPERATIONS

MENTAL ROTATION

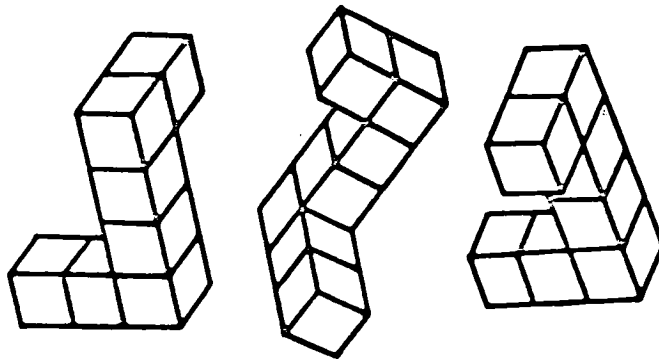

PAIR A
"SAME"

PAIR B
"DIFFERENT"

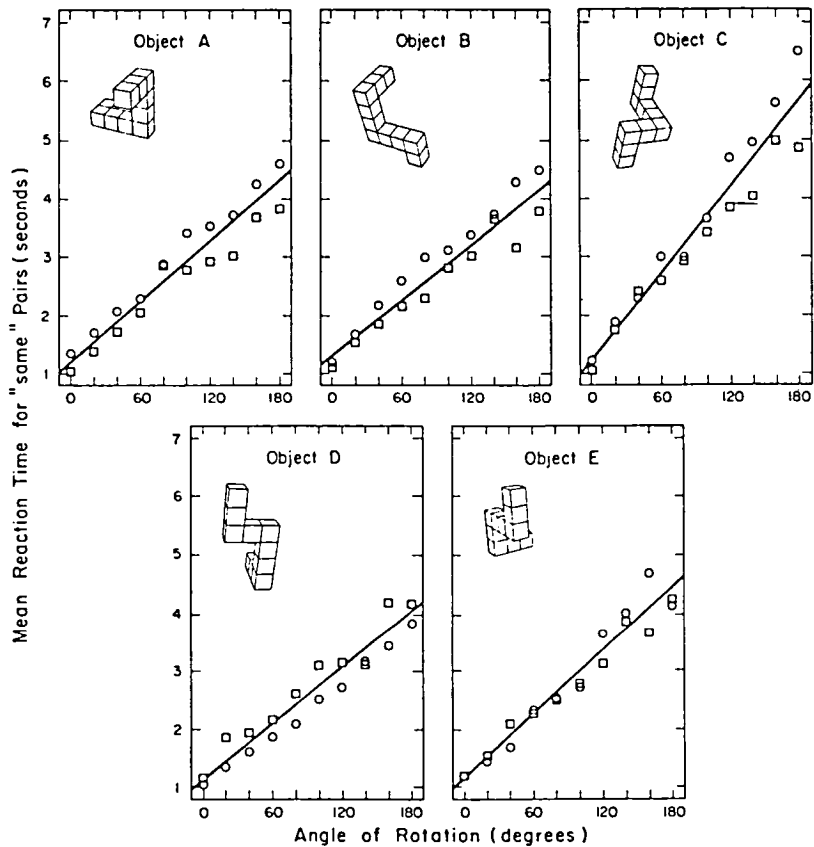

OBSERVERS IMPOSE KINEMATIC AND KINETIC CONSTRAINTS ON AMBIGUOUS VISUAL DISPLAYS

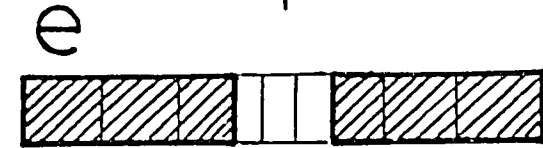
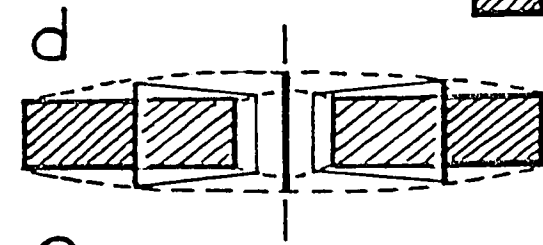
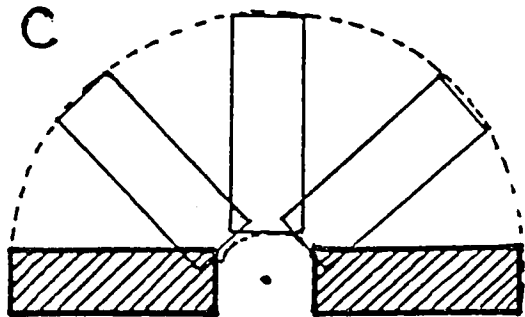
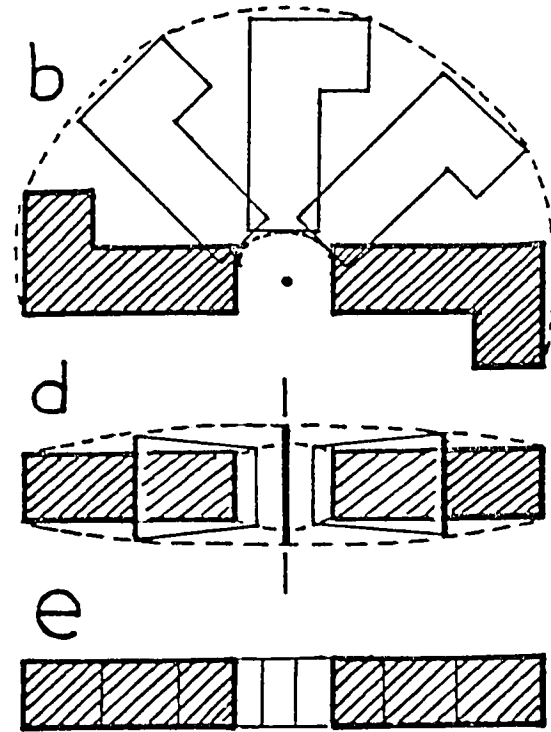
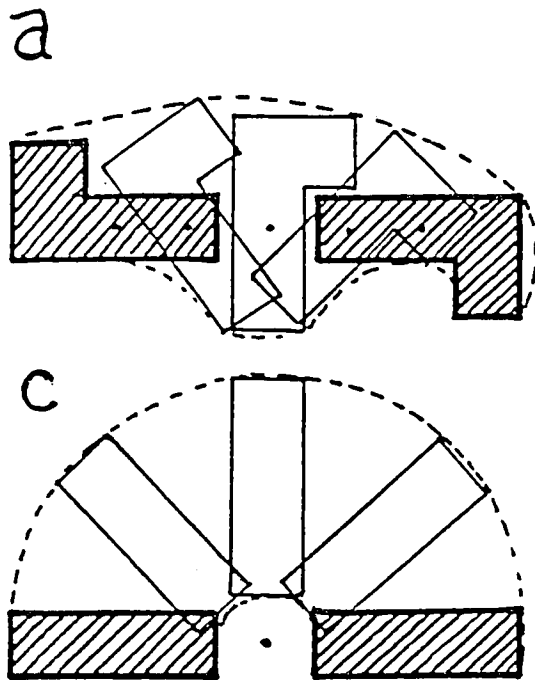

THREE POSSIBLE STRUCTURES FOR A DATA "ENVIRONMENT"

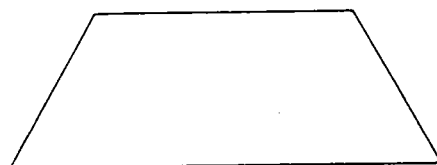

Large Single Plane

a

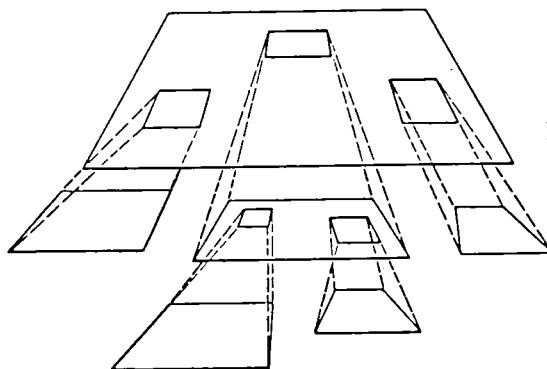

Nested Data Planes

b

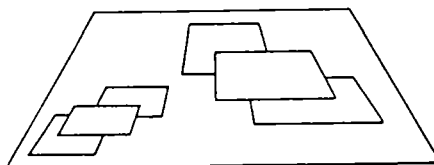

Single Plane with Stacked "Windows"

c

VIRTUAL INTERFACE ENVIRONMENT

Scott S. Fisher
NASA Ames Research Center
Moffett Field, California 94035

Abstract

A head-mounted, wide-angle, stereoscopic display system controlled by operator position, voice and gesture is under development for use as a multipurpose interface environment. Initial applications of the system are in telerobotics, data-management and human factors research. System configuration and research directions are described.

1. Objective

The objective of this research effort is to develop a multisensory, interactive display system in which a user can virtually explore a 360-degree synthesized or remotely sensed environment and viscerally interact with its components. This work is done in the context of developing a multipurpose operator interface 'environment' to facilitate natural interaction with:

- Complex operational tasks such as control of remotely operated robotic devices and vehicles that require a sufficient quantity and quality of sensory feedback to approximate actual presence at the task site.
- Large-scale integrated information systems in which data manipulation, storage and retrieval and system monitoring tasks can be spatially organized.

An additional research objective includes use of this display system to synthesize interactive test environments for aerospace human factors research in such areas as: spatial habitability research, rapid prototyping of display and workstation configurations, research on effective transfer of spatial information, and spatial cognition research on multisensory integration.

2. System Configuration

The virtual environment display system consists of: a wide-angle stereoscopic display unit, glove-like devices for multiple degree-of-freedom tactile input, connected speech recognition technology, speech-synthesis technology, gesture tracking devices, and computer graphic and video image generation equipment.

The present display unit is helmet-mounted and consists of monochromatic liquid crystal display screens presented to each eye of the user through wide-angle optics. The effective field of view for each eye is 120 degrees for horizontal and vertical. Imagery displayed on the screen is generated by computer, remote video sources or a combination of input media. Head motion of the user is tracked by a sensor mounted on the helmet and the derived position and orientation data is used to update the displayed stereo images in response to the users activity. As a result the displayed imagery can appear to completely surround the user in 3-space.

Presented at the Space Station Human Factors Research Review, December 3 - December 6, 1985. NASA Ames Research Center, Moffett Field California, 94035.

To interact with the displayed three dimensional environment, the user wears lightweight glove-like devices that transmit data-records of arm, hand and finger shape and position to a host computer. In coordination with connected speech recognition technology, this information is used to effect indicated gestures in the synthesized or remote environment. Current examples of research in voice and gesture mediated interaction is the control of robotic arms and end-effectors, and associated control of auxillary camera positions. Similarly, in a data management environment, windows of information or virtual control panels are positioned, sized and activated in 3-space.

Current experimental research includes system calibration for orthoscopic image display, evaluation of operator performance in teleoperation placement tasks, and analysis of perceived localization of synthesized sound sources in 3-space.

3. Conclusions

Unlike most contemporary 360-degree visual simulation environments, the virtual environment display system does not make use of large, expensive, special purpose projection configurations; The described system is portable and low-cost without large space and equipment requirements. Unlike other research efforts in head-mounted displays, this system is unique in presenting a stereoscopic image that fills the user's field of view completely and in its configuration with speech and tactile input technology.

As a research tool, the virtual environment display system follows many research efforts to develop operator control stations for teleoperation and telepresence but has a unique configuration to investigate natural, multisensory interaction with complex operational tasks. As an interface for data management tasks, this system is a continuation of recent research in multimodal, natural input technology and concentrates on development of a true three dimensional data space interface that can be easily reconfigured for idiosyncratic users.

**VIRTUAL INTERFACE ENVIRONMENT
TELEPRESENCE**

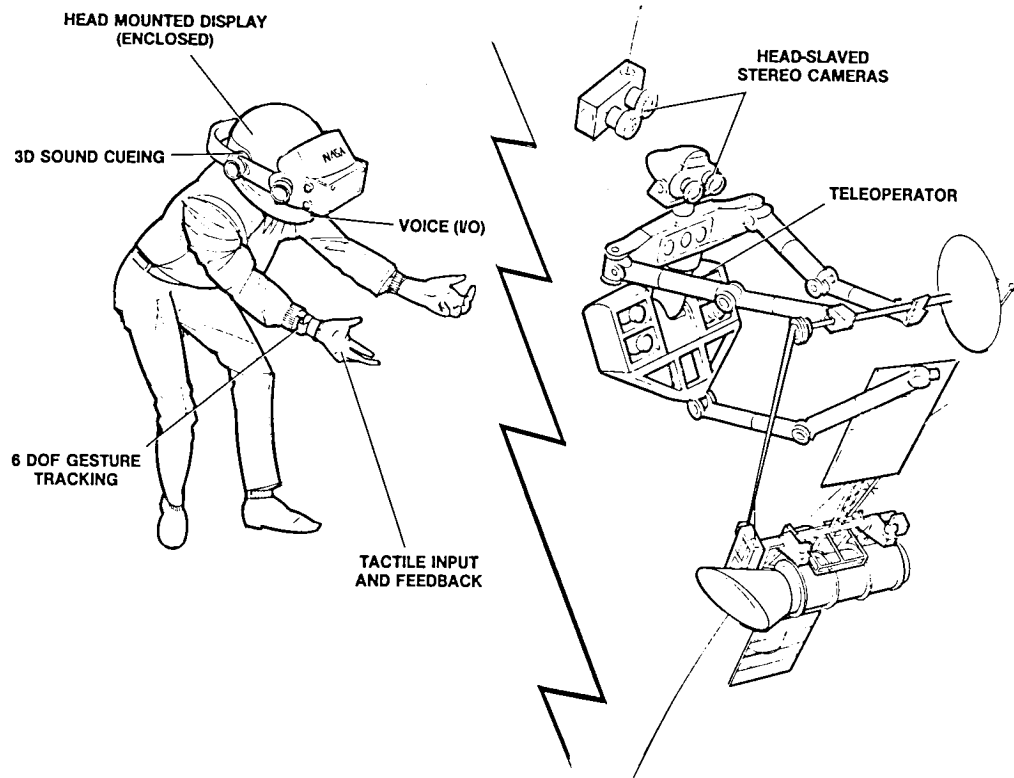

**VIRTUAL INTERFACE ENVIRONMENT
SPACE STATION SYSTEMS AND DATA MANAGEMENT**

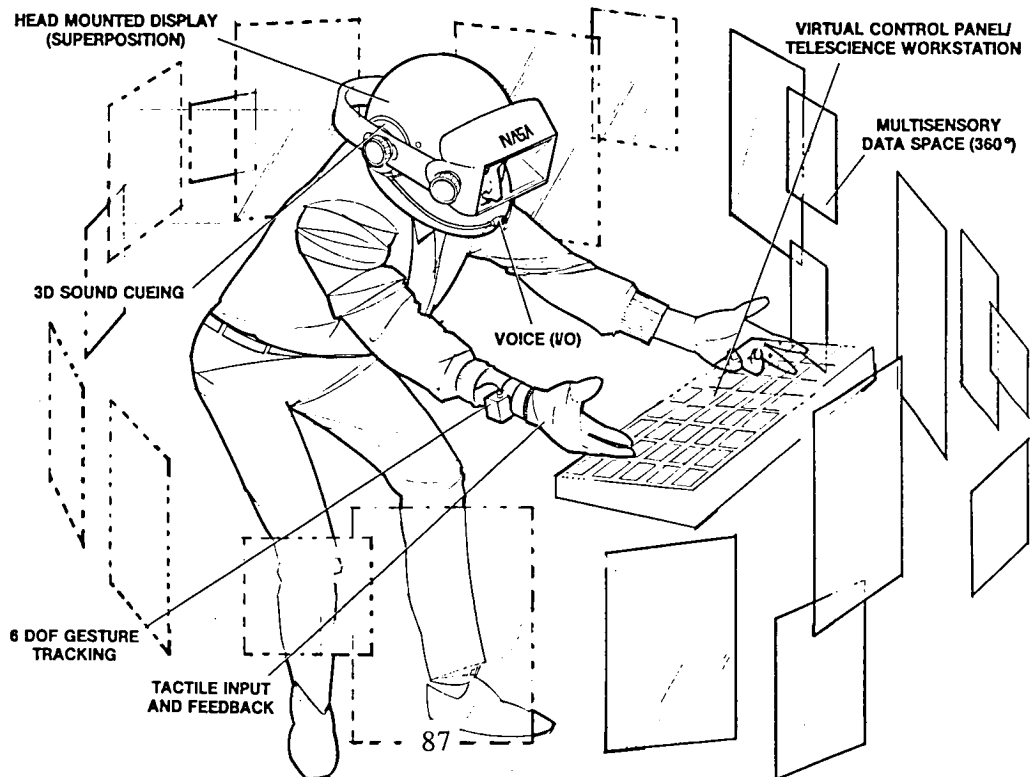

FAULT DIAGNOSIS IN ORBITAL REFUELING OPERATIONS¹

Guy A. Boy²
ONERA-CERT-DERA³
2, avenue Edouard Belin
31055 Toulouse Cedex
France

Abstract

Usually, operation manuals are provided for helping astronauts during space operations. These manuals include normal and malfunction procedures. Transferring operation manual knowledge into a computerized form is not a trivial task. This knowledge is generally written by designers or operation engineers, and is often quite different from the user logic. The latter is usually a "compiled" version of the former. Experiments are in progress to assess the user logic. HORSES (Human - Orbital Refueling System - Expert System) is an attempt to include both of these logics in the same tool. It is designed to assist astronauts during monitoring and diagnosis tasks. Basically, HORSES includes a situation recognition level coupled to an analytical diagnoser, and a meta-level working on both of the previous levels. HORSES is a good tool for modeling task models and is also more broadly useful for knowledge design.

Keywords: On-Line Expert System, Man-Machine Interactions, Process Control, Diagnosis System, Knowledge Design, Task Models, Situation Recognition.

¹ This paper will be presented at the Space Station Human Factors Research Review, NASA Ames Research Center, December 3 to December 6, 1985.

² This work was completed when the author was a Research Associate at NASA-Ames Research Center, Aero-Space Human Factors Research Division, Mail Stop 239-3, Moffett Field, CA 94035, U.S.A..

³ ONERA: Office National d'Etudes et de Recherches Aeronautiques ; CERT: Centre d'Etudes et de Recherches de Toulouse ; DERA: Departement d'Etudes et de Recherches en Automatique.

Fault Diagnosis In Orbital Refueling Operations

Guy A. Boy

Space Station Human Factors Research Review
NASA Ames Research Center
December 6, 1986

1. Problem Definition

Human-Machine Interactions in Normal and Abnormal Situations

□ Understanding the HMI Logic

- △ Human Operator Model
- △ System Logic vs. User Logic

□ Need for, and Limitations of AI Tools in System Operations

- △ An Example : The ORS

□ Building A User's Guide Expert System

- △ Operation Manual
- △ An AI Tool, why ? (modularity,
flexibility, ...)
- △ Human vs. Automatic Diagnosis
- △ Human-Expert-System Interactions

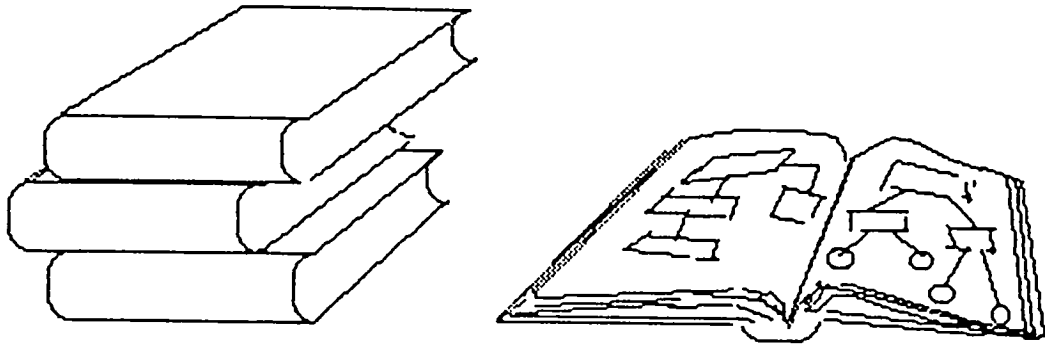

TIME ?
PROCEDURES ?
LEVELS OF AUTOMATION ?
EASY-TO-USE ?
EXPLANATION ?

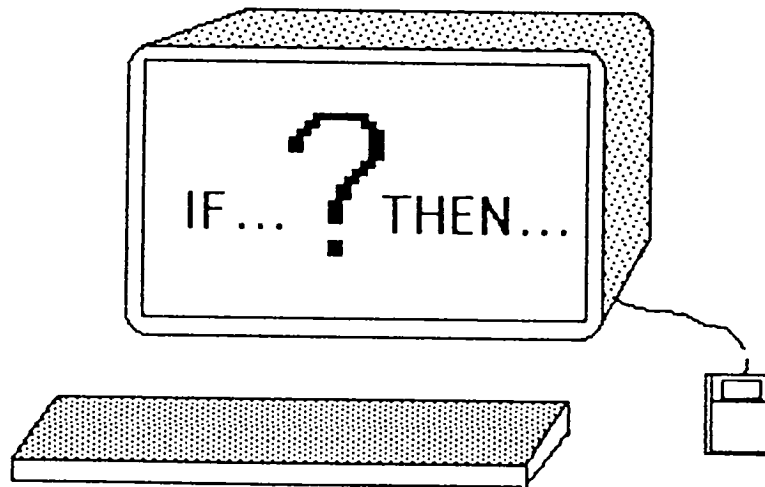
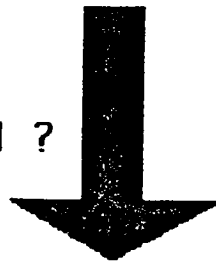

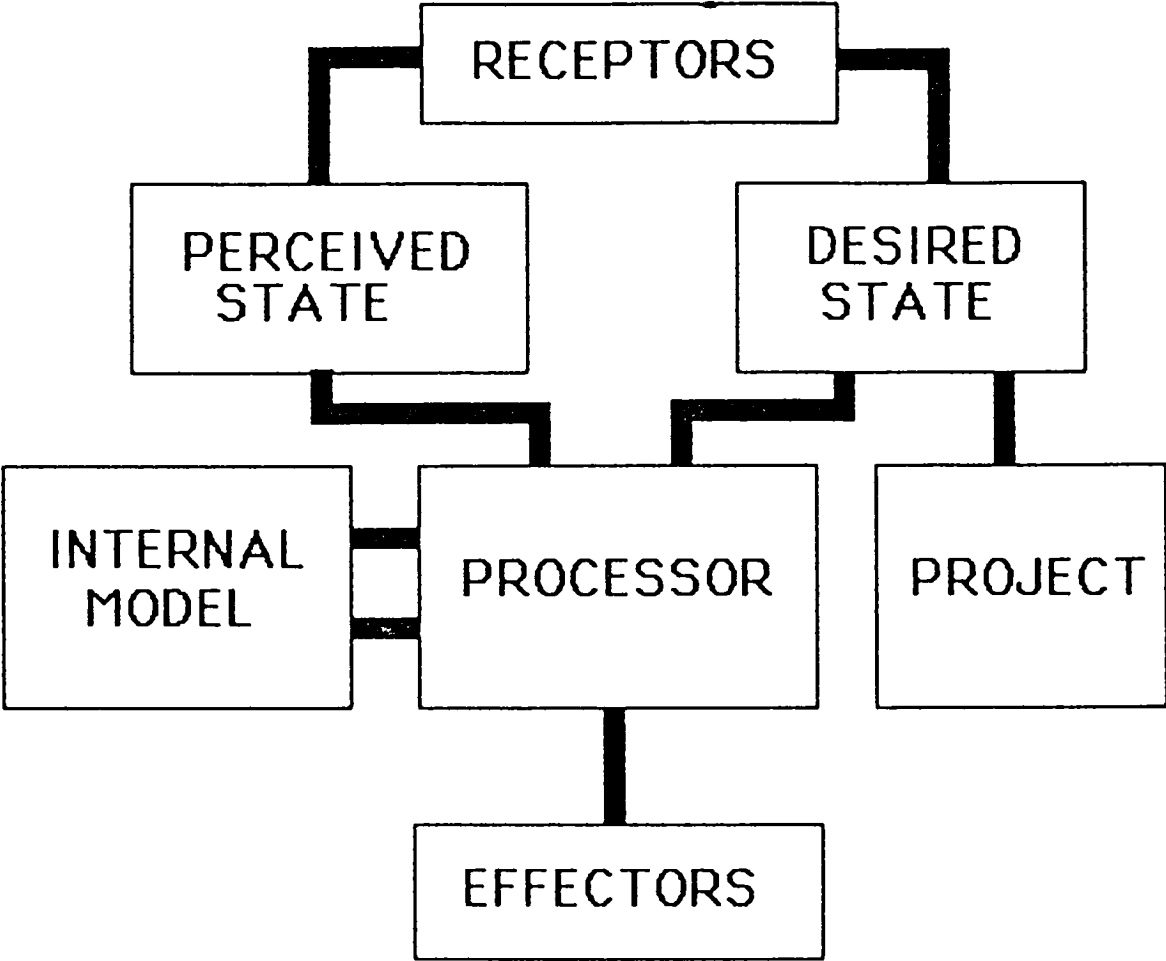

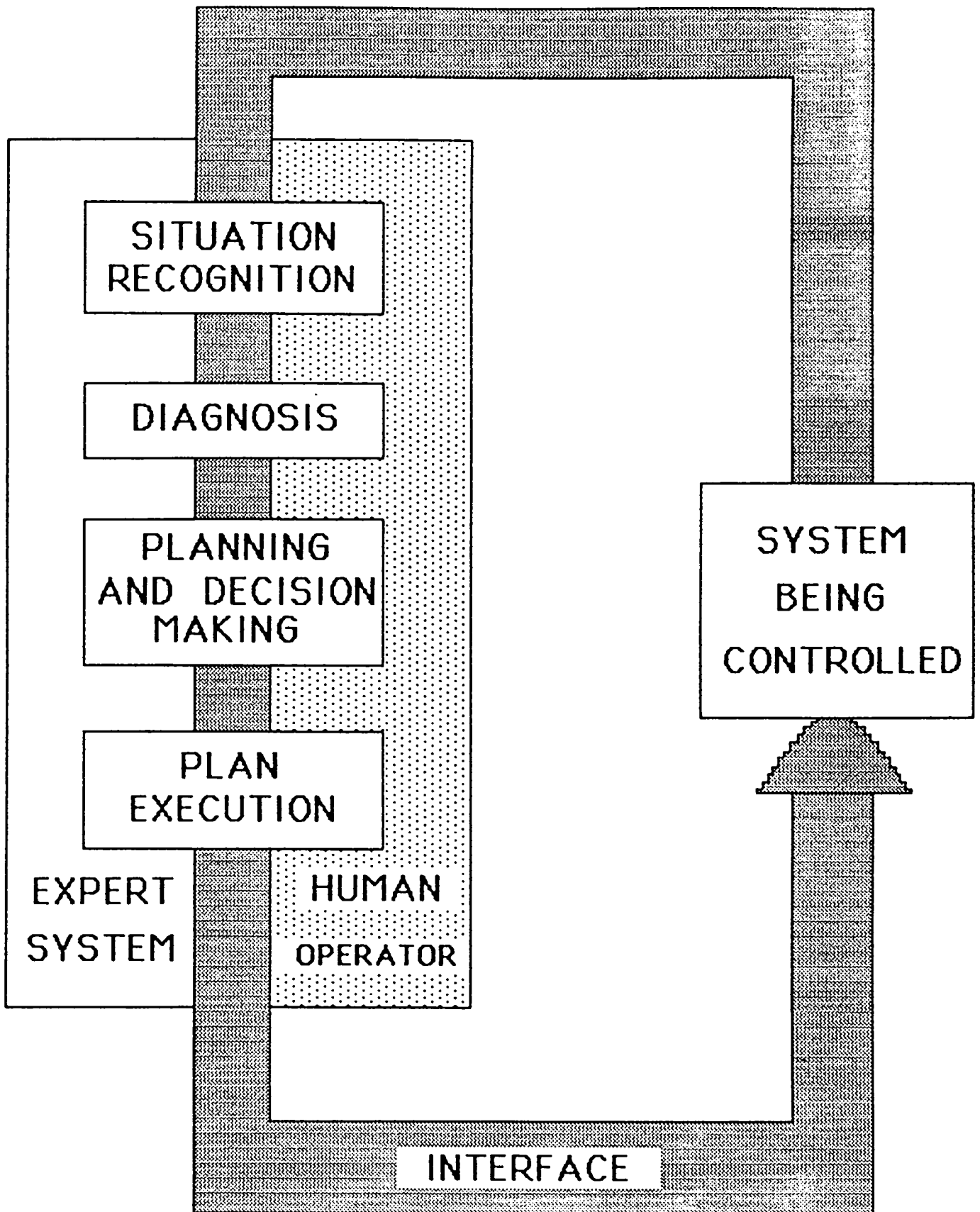

LANDSAT-D REFUELING

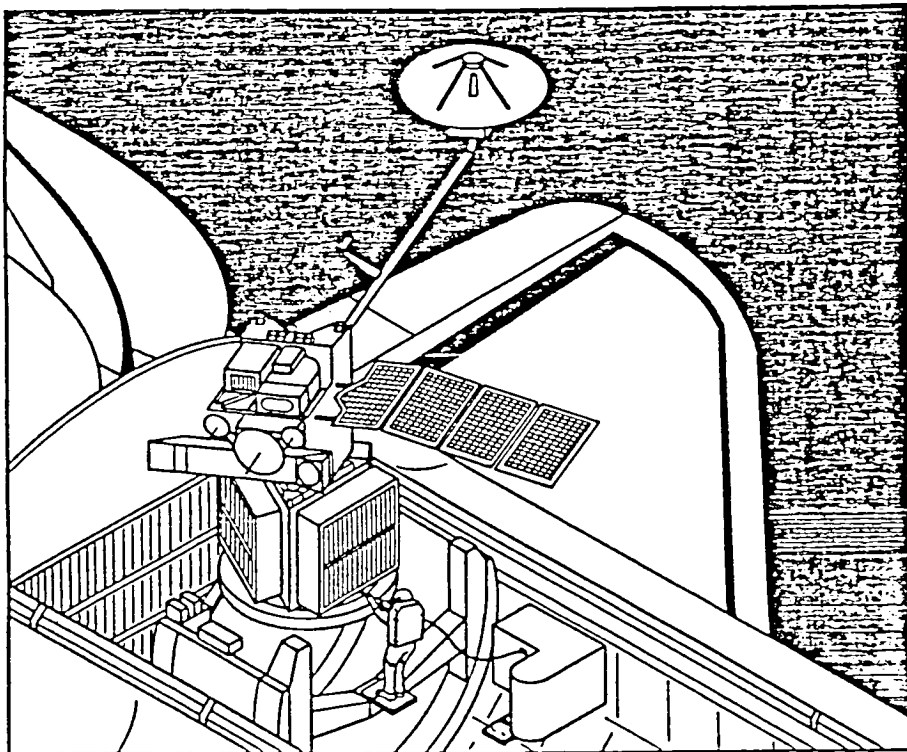

Landsat-D will utilize the ORS equipment and procedures for propellant replenishment.

ORS PROTOTYPE FLOW SCHEMATIC

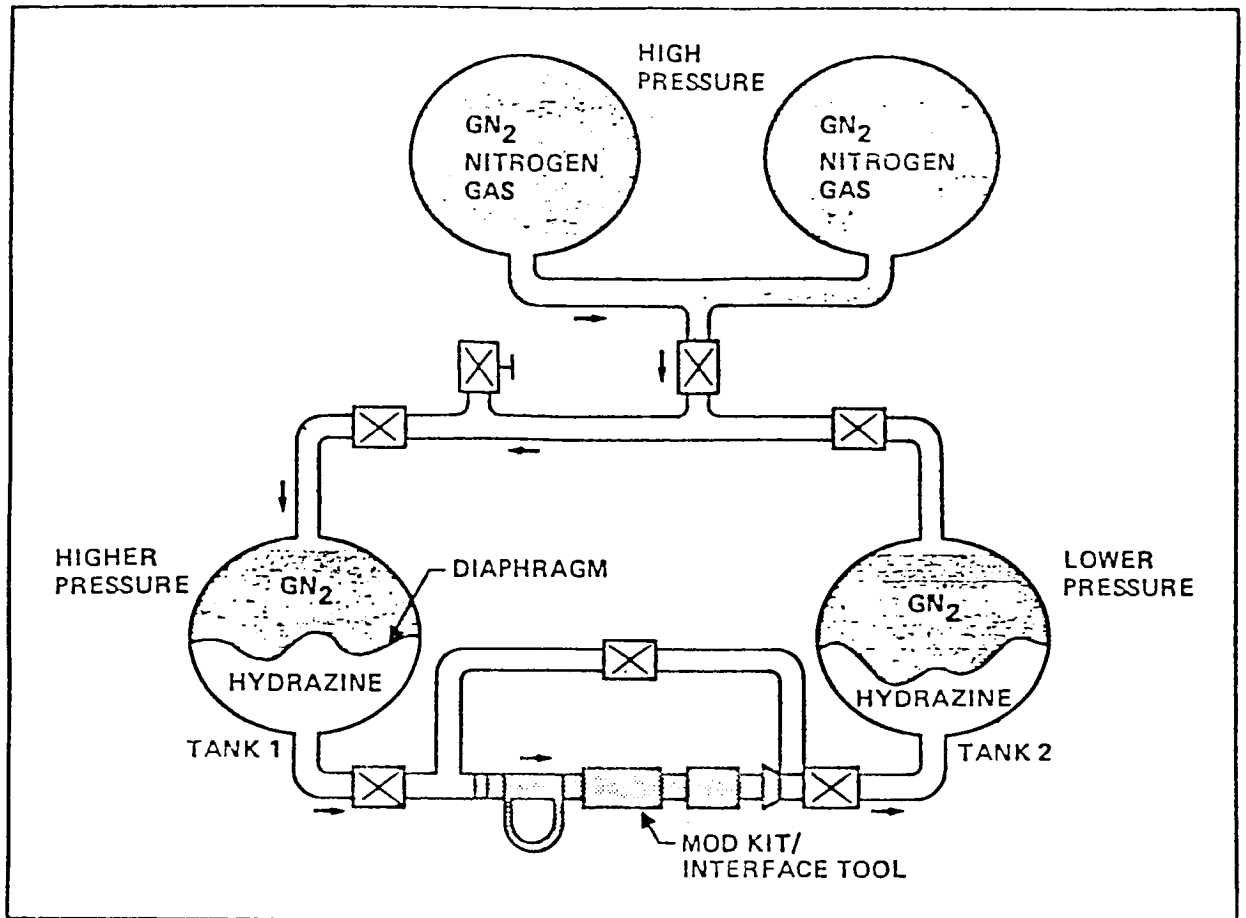

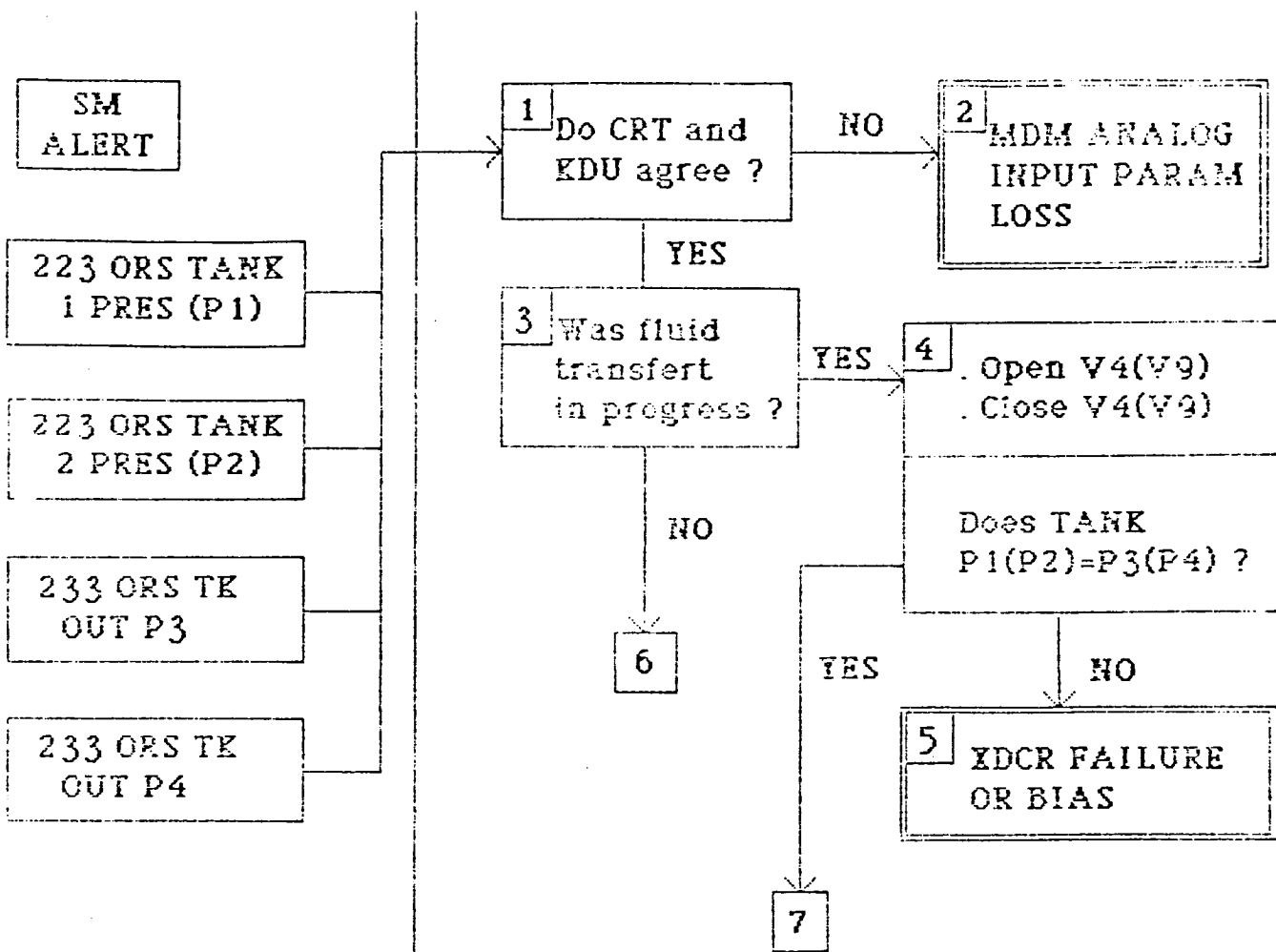

If ;

TANK 1(2) PRES

> 370 psia

< 20 psia

TK OUT P3(P4)

> 450 psia

< 20 psia

Example : Malfuction Procedure

1.4b ORS TANK 1(2) PRES

ORS TK OUT P3(P4)

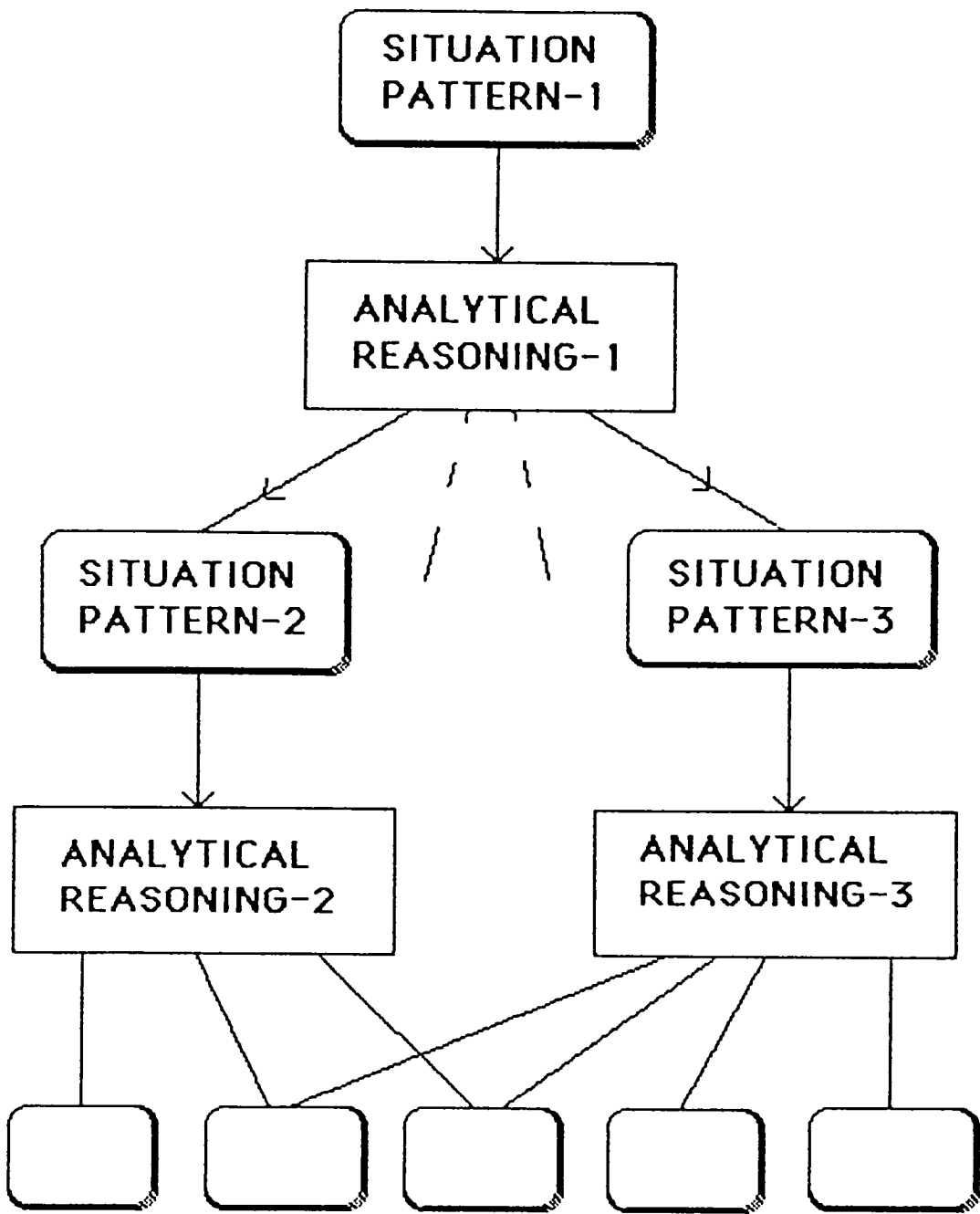

SITUATIONAL AND ANALYTICAL PROCESSES

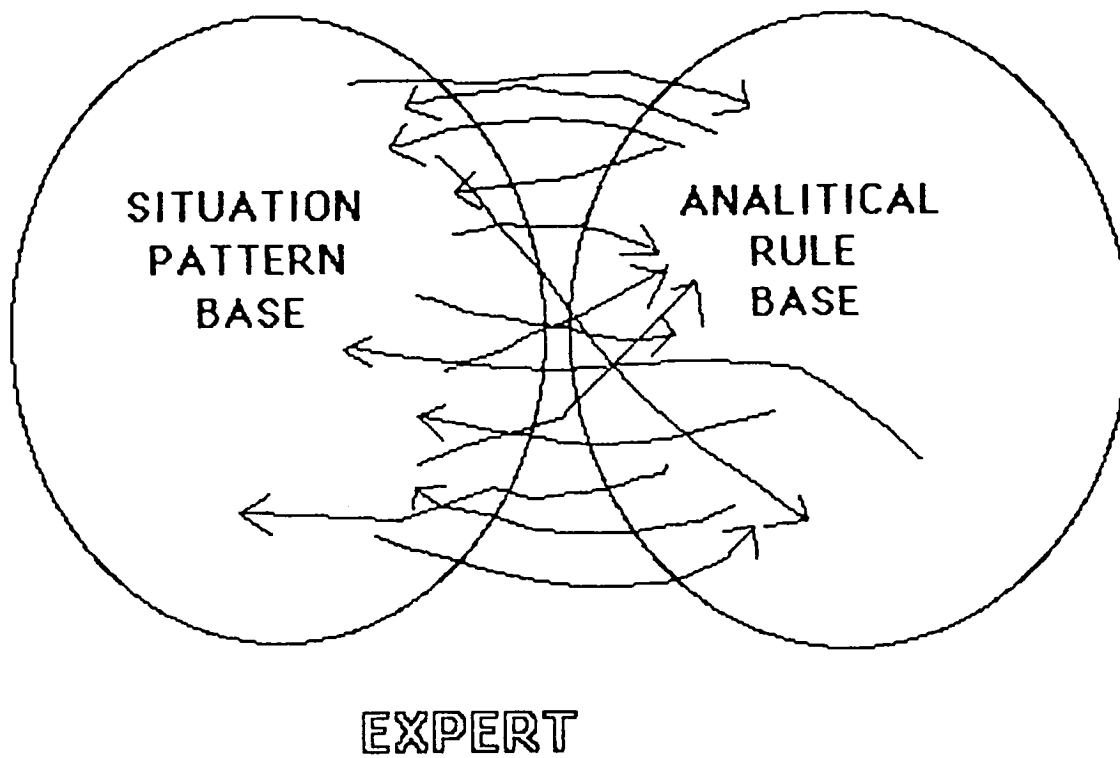
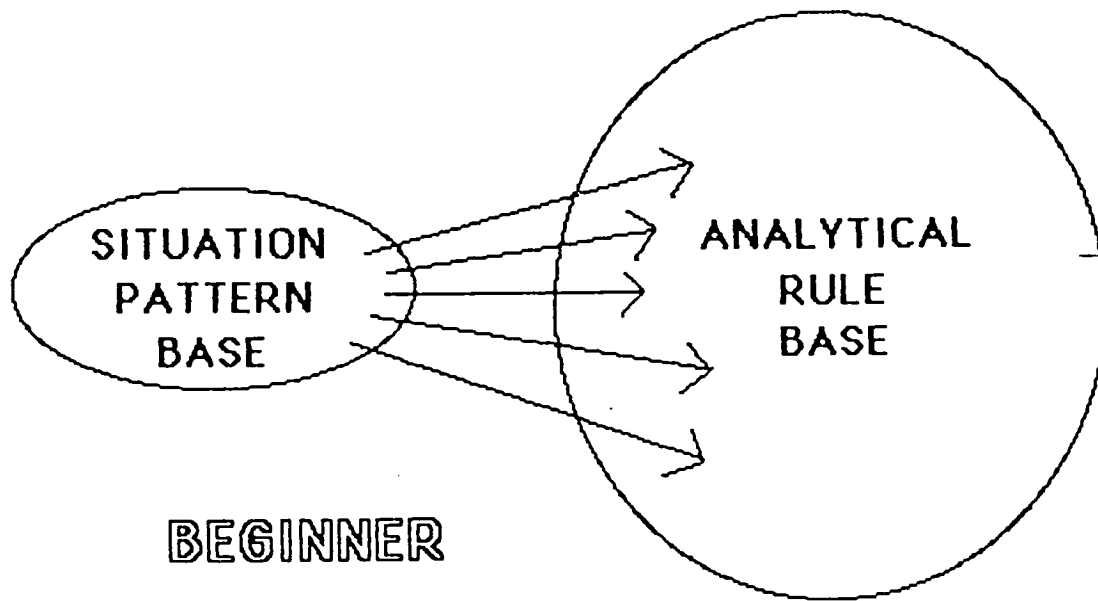

2. Building a User's Guide Expert System

□ Goals

- △ Optimal Level of Automation
- △ Explanation
- △ Easy-to-Use Interface

□ Methods

- △ Modelling Approach
- △ Human Factors Studies
- △ Triangular Interactions

□ Tasks

- △ Building an Expert System
- △ Experiments
- △ Theoretical Studies

□ Product

- △ Tool to Design Procedures
- △ Diagnosis Aid

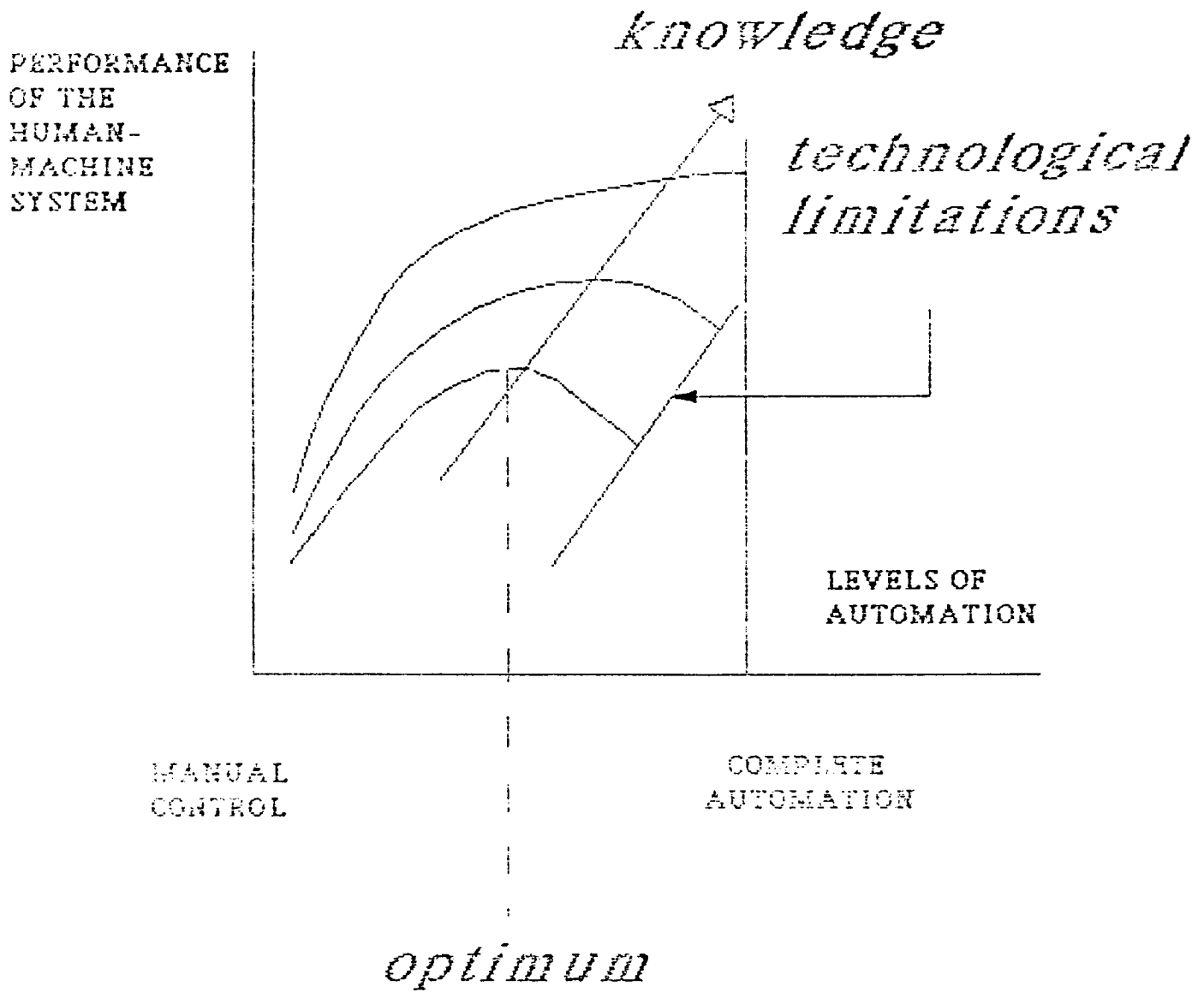

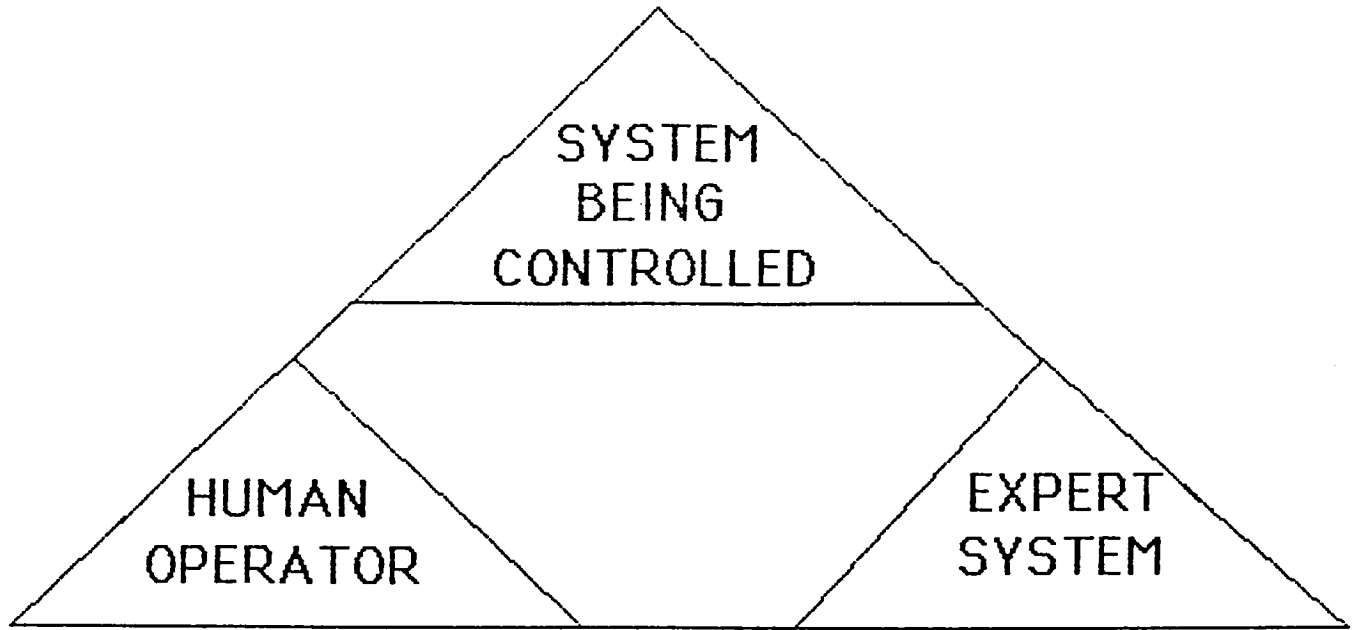

Human – ORS – Expert System

□ Processor

- △ Situation Recognition (Monitoring)
- △ Diagnosis Inference Engine (2 levels)

□ Knowledge Base

- △ Context Rules
- △ Regular Rules
- △ Meta Rules
- △ Predicates
- △ Tolerance Functions
- △ Objects

□ Interfaces

- △ User Interface (Question–Answer, Menus)
- △ ORS Interface (Fact Filter, Fuzzy Models)

HORSES BACKGROUND

MESSAGE

(ONERA / Airbus Industrie)
(Certification, Workload & Performance Analyses)

SEAGOS

(ONERA / Matra)
(Satellite Malfunction Procedures)

HORSES

(NASA / ONERA)
(ORS Malfunction Procedures)

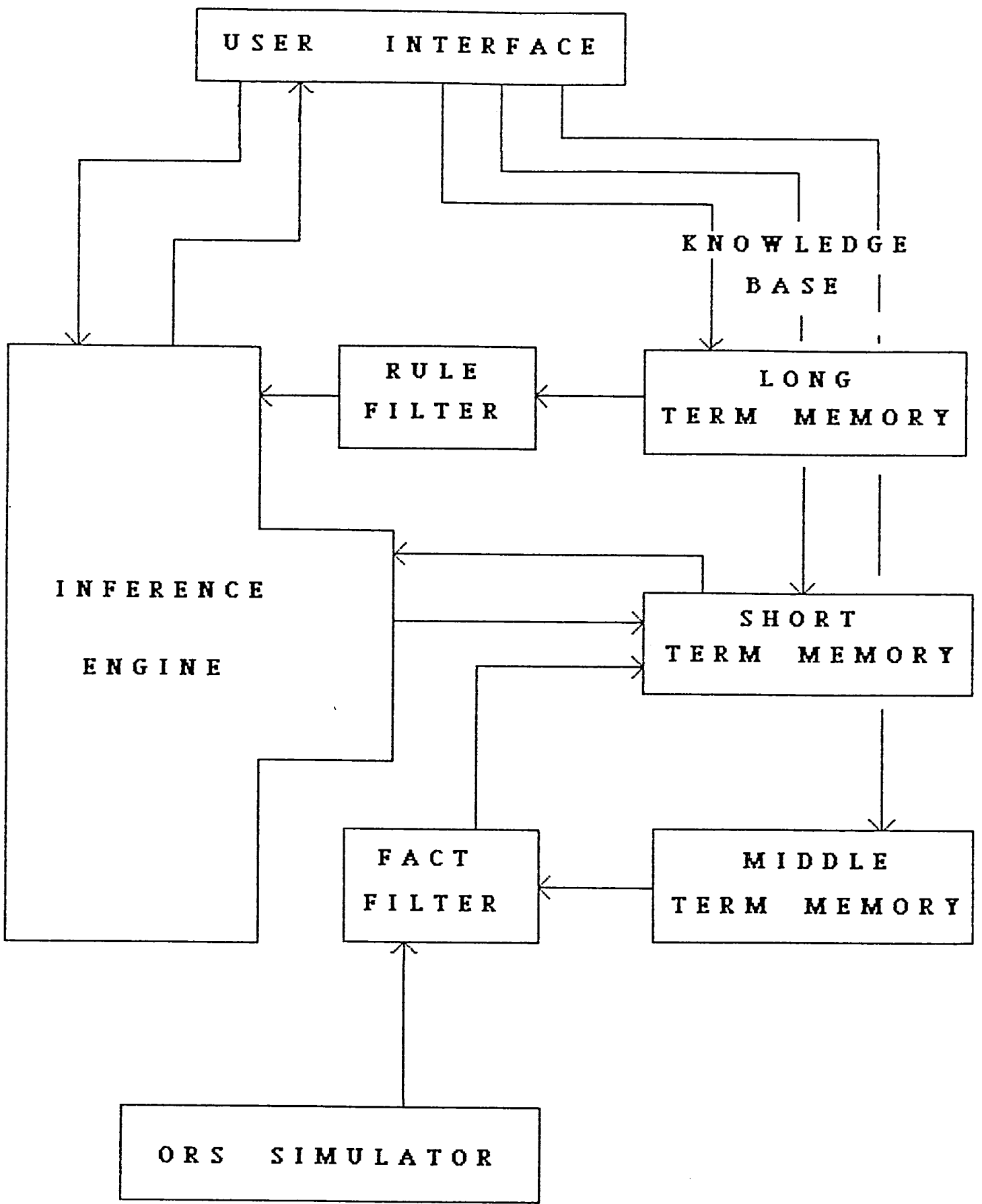

HORSES Current Version

- Working in Lisp on MASSCOMP
- Connected to an ORS Fortran Simulation
- Graphic Interface (Windows, Color)

THE WINDOWS

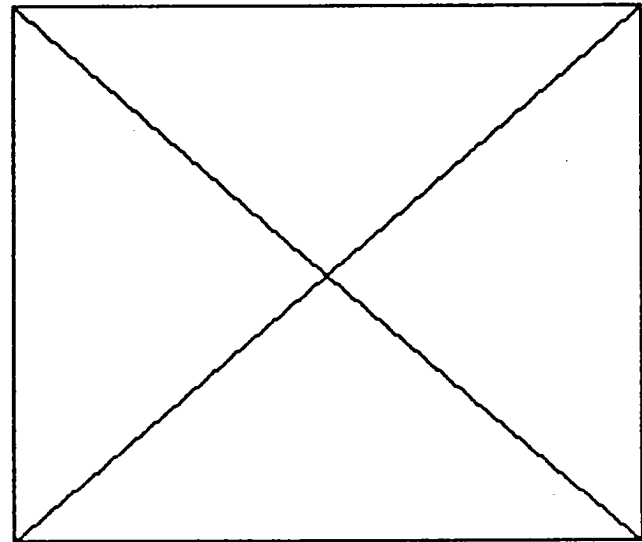
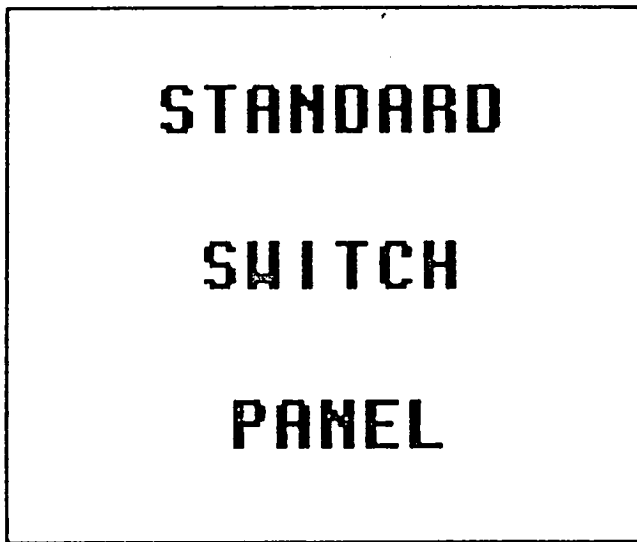
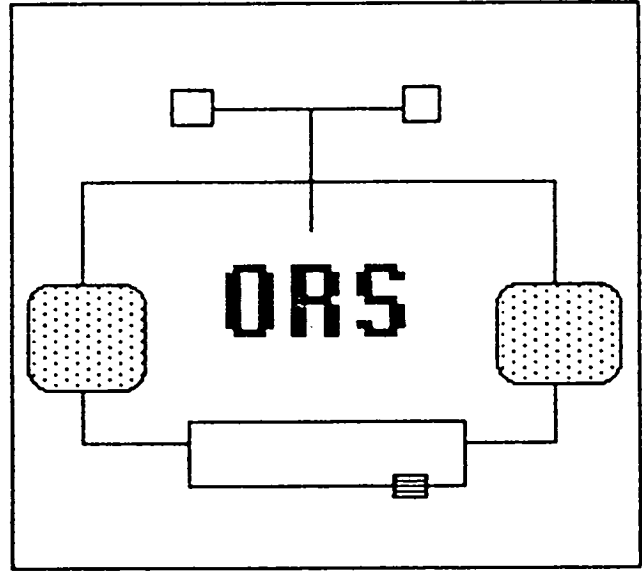
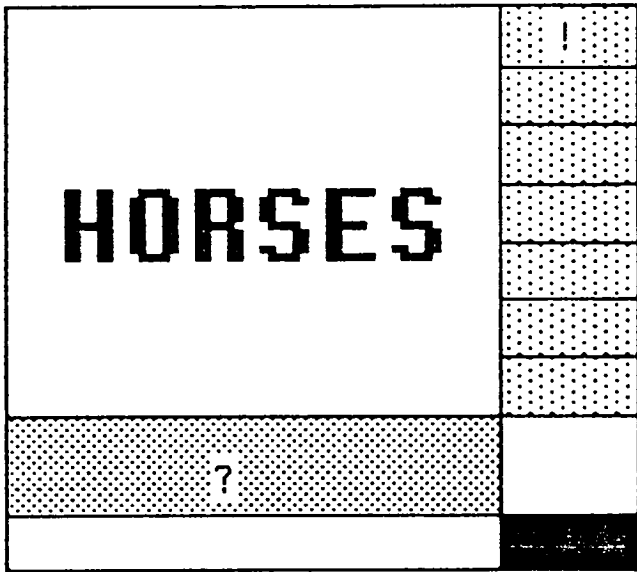

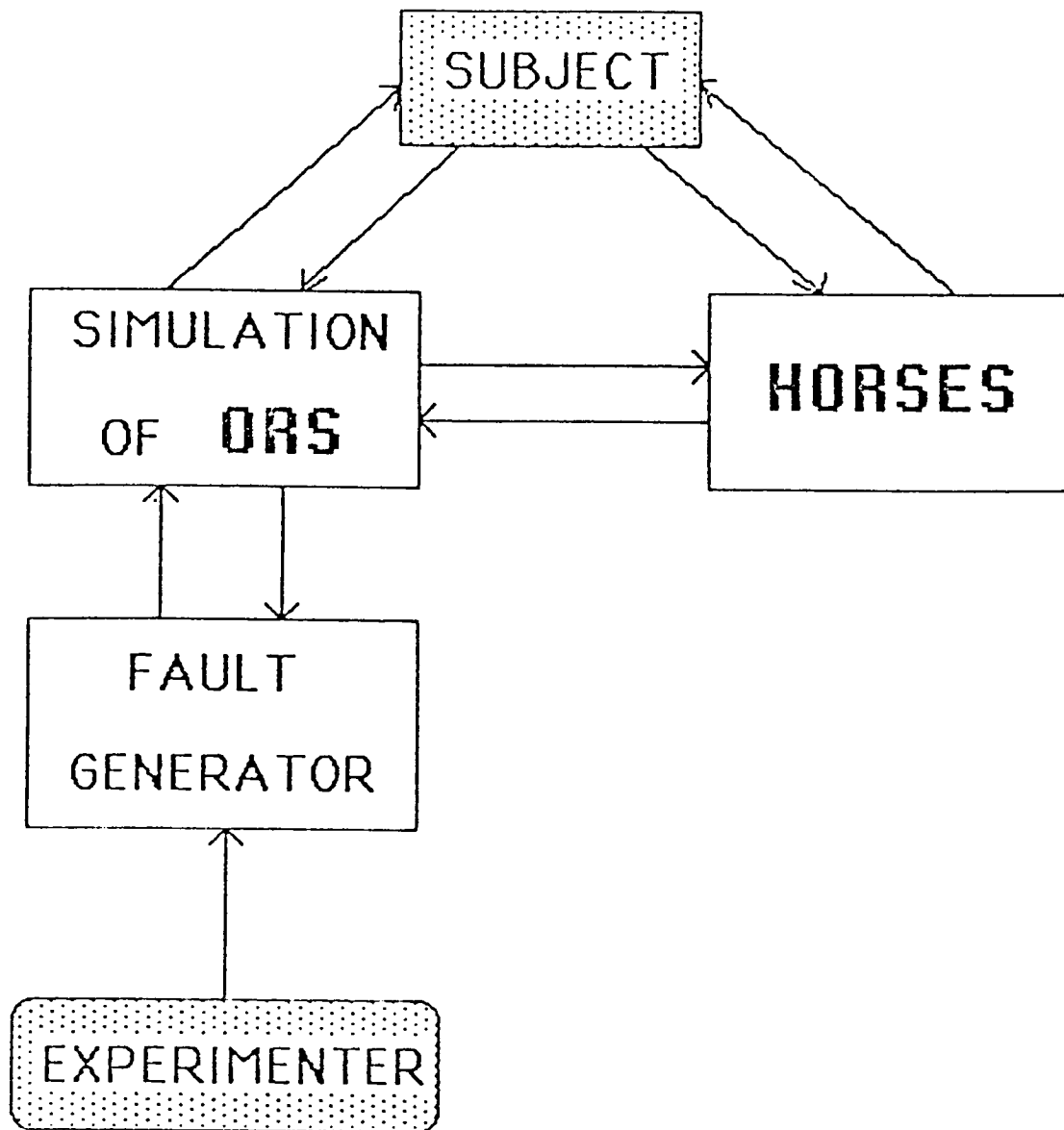

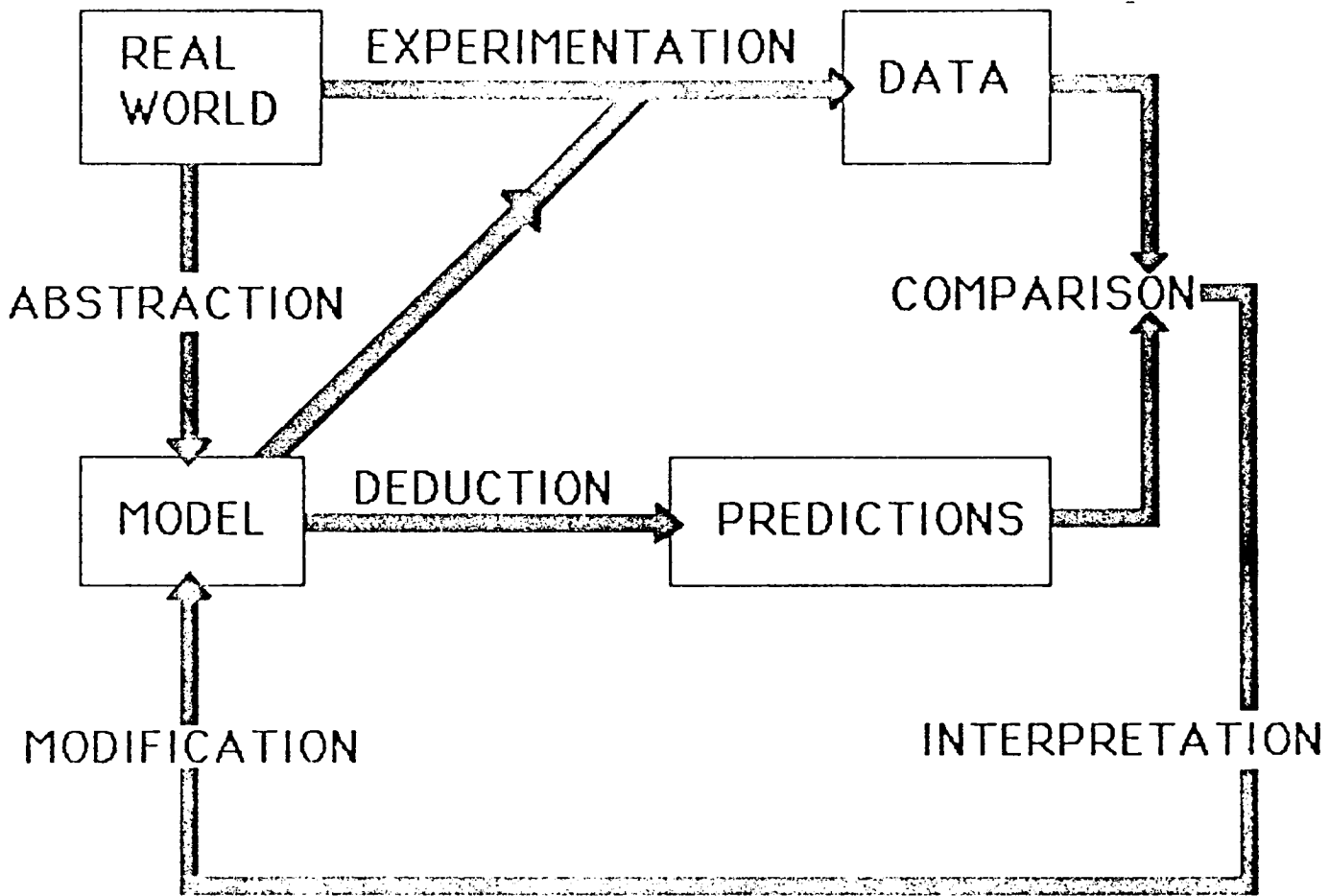

Further Studies

- Experiments on Man-Machine Interactions
 - △ Level 0 (Paper Manual)
 - △ Level 1 (Expert System Guides and Advises)
 - △ Level 2 (Automatic Diagnosis, Explanation)

- Situation Recognition
 - △ Experiments on Qualitative Models
 - △ Fuzzy Sets Approach

- Explanation
 - △ Information on Time and
at the Appropriate Level of Detail
 - △ Graphic Displays

- Knowledge Editor
 - △ Consistency
 - △ Graphic Displays

Operator Assistant

- COMPUTERIZED OPERATION MANUAL
- SITUATION RECOGNITION SYSTEM
- COOPERATIVE DIAGNOSIS ADVISOR
- DIFFERENT LEVELS OF AUTOMATION
 - DYNAMIC AND INTERACTIVE
 - EASY-TO-USE

Tool for Implementing Task Models

- KNOWLEDGE DESIGN
- KNOWLEDGE PROCESSING
 - VISUAL THINKING
- GRAPHICAL INTERFACE

ERROR-TOLERANCE AND PROCEDURE AIDS

EVERETT PALMER

**AERO-SPACE HUMAN FACTORS RESEARCH DIVISION
AMES RESEARCH CENTER
NASA**

SPACE STATION HUMAN FACTORS RESEARCH REVIEW

INHOUSE ADVANCED DEVELOPMENT AND RESEARCH

**NASA-AMES RESEARCH CENTER
MOFFETT FIELD, CALIFORNIA**

DECEMBER 6, 1985

ERROR-TOLERANCE AND PROCEDURE AIDS

EVERETT PALMER

- Approaches to the Problem of Human Error.
- The Concept of Error Tolerance
- Research Focus – Past and Present
- A Conceptual Design for an Error Tolerant System

Human Error

The Problem.

- Human error is the primary cause of 60 to 90% of major accidents.

Standard Approaches to Reducing Human Error.

- Procedures
- Interlocks
- Warnings
- Automation

Possible Result of these Approaches, if Taken Too Far.

- Operator Out of the Loop
- Reduced Ability to Cope with the Unexpected

Why Have a Human in the System?

- **A Primary Reason is to Cope with the Unexpected by Innovating.**
 - › Flexible, Adaptive Information Processors
 - › Recognize Patterns
 - › Make Associative Leaps
 - › Persevere in Ill-Structured, Ambiguous Environments
- **The Cost of these Benefits**
 - › Human Errors
- **Apparent Dilemma :**
 - › Human Innovation vs. Human Error
- **Errors are Not Inherently Unacceptable**
- **Errors can be Tolerated if the Consequences of Error Can be Controlled**

Aeronautics Technology - Possibilities for 2000
Aeronautics and Space Engineering Board
National Research Council

Error Tolerance vs. Error Reduction

- **Error Tolerance**

- › Focus on the Observable End of the Causal Chain Leading to the Error.
- › Focus on Explanations and Compensations for Particular Problems that Have Occured.

- **Error Reduction**

- › Emphasizes Upstream Aspects of the Problem.
- › Concerned with Probabilities of All Potential Problems That Might Occur.

Research Focus: Procedure Error Detection

Motivation:

- Procedures are an essential part of the operation of any complex dynamic system.
- Error detection is the first requirement of an error tolerant system.

Goal:

- To design systems that understand the goals and plans of their human operators and that can use this knowledge to detect and inform the operators of possible human errors.

Research Focus: Procedure Error Detection

Objective:

- Develop a software system that can detect procedural errors in the operation of aero-space systems.

Approach:

- Base the system on script based AI programs that understand human actions in simple stories.
- Develop a hierarchial script based program to detect procedural errors in a general aviation simulator.
- Extend the program to detect errors in a full mission B-727 aircraft simulator.
- Incorporate the program concepts into a "SMART CHECKLIST" for the Advanced Cockpit Flight Simulator" and a space shuttle payload.

Background Research:

- **Georgia Tech Grant**
(Bill and Sandra Rouse, John Hammer)

- **Experimental Evaluation of Electronic Checklists**
 - › Full Mission General Aviation Flight Simulator

 - › Checklist Display Conditions
 - ›› Hard Copy - Paper
 - ›› Aided Soft Copy - CRT

 - › Results
 - ›› Hard Copy: 19% faster
 - ›› Aided Soft Copy: 7.5 times fewer errors

Automatic Procedure Error Detection

- **Initial Objective:**
 - > Data Analysis Tool
 - > Detect Errors:
 - Omitted
 - Incorrect
 - Out-of-Order

- **Ultimate Objective:**
 - > Real Time Feedback to the Crew

- **Infer Current Procedure – Track Context**

- **Story Understanding → Crew Action Understanding**

- **Scripts:**
 - > A script describes the actors and actions that can be expected to occur in a given situation.

- **Hierarchical Tree Structure**

- **A model of the human for the system.**

Automatic Procedure Error Detection

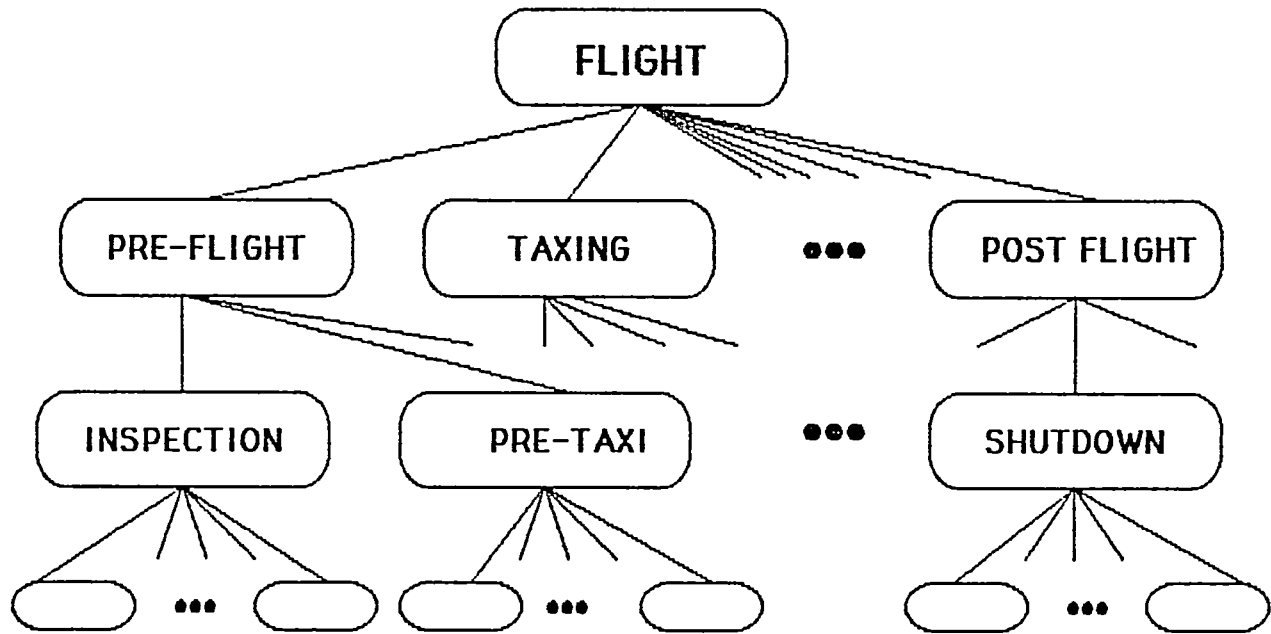

Tree of steps, procedures, phases and flight.



State transitions for tree nodes

Current Projects at NASA Ames

1) Procedure Error Detection in a 727 Simulator

2) "Smart Checklist"

- **Applications:**

- › The Orbiting Refueling System - the ORS
- › Space Shuttle Ground Control - the INCO Position
- › The Advanced Cockpit Flight Simulator

- **Operational Modes:**

- › Browser
- › Editor
- › Monitored (Management by Exception)
- › Automatic (Incremental Automation)

- **Features:**

- › Call up relevant schematic display
- › Highlight relevant information on the schematic
- › Show desired or expected state
- › Show actual state
- › Show if procedure step is satisfied

- **Goal Sharing**

- **Goal Inference vs. Goal Communication.**

An Example of the "Smart Checklist" for the ORS

<u>ORS</u>				IN-PROGRESS
<u>TRANSFER 1</u>				IN-PROGRESS
SM 223 ORS SUMMARY			DONE	
<u>1 Configuration Checks</u>				IN-PROGRESS
✓ ORS HTR A	OFF		OFF	DONE
✓ <u>HRT B</u>	<u>AUTO</u>		OFF	IN-PROGRESS
✓ SW ENA	INH		OFF	
✓ VDE PWR	OFF		OFF	
✓ TANK 1 P1	260 ± 15 psi		254	
✓ TANK 2 P2	130 ± 15 psi		146	
✓ TANK 2 T2	< 80 degF		86	
✓ V3	OP		OP	
✓ V7	OP		OP	
✓ V1	CL		CL	
✓ V4	CL		CL	
✓ V5	CL		OP	

A Conceptual Design for an Error-Tolerant System

- **System Functions:**

- > Error Identification
- > Error Classification
 - >> Slips vs Mistakes
- > Error Remediation

- **Design Philosophy:**

- > Non-Intrusive Monitoring
- > Incremental Intervention
- > Dependence without Loss of Control

- **Design Issues:**

- > How and When Should the Crew be Informed of Their Errors?
- > Can the System be Supportive without Also Being a Nag?
- > If there is Disagreement, Who is In Charge?

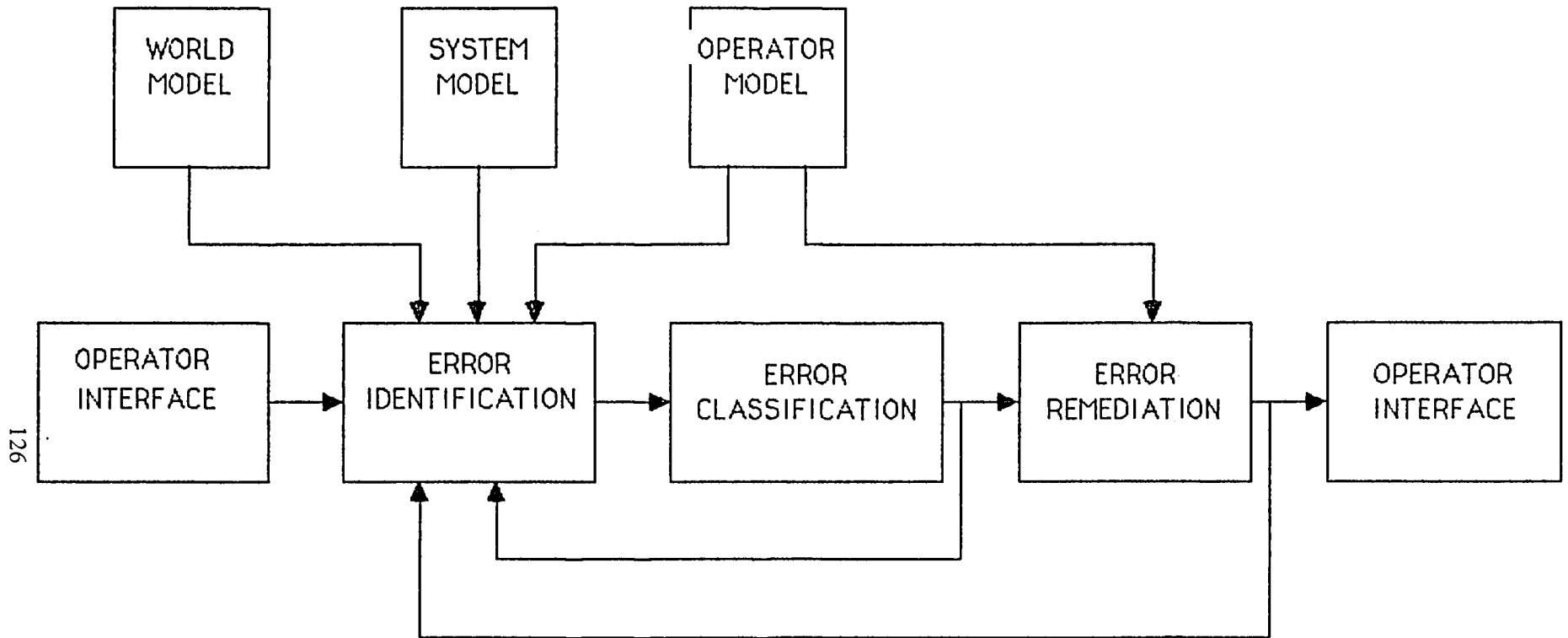

126

Architecture for an Error-Tolerant System

(from Rouse and Morris)

Automatic Procedure Error Detection

GOAL:

- TO DESIGN SYSTEMS THAT UNDERSTAND THE GOALS AND PLANS OF THEIR HUMAN OPERATORS AND THAT CAN USE THIS KNOWLEDGE TO DETECT AND INFORM THE OPERATORS OF POSSIBLE HUMAN ERRORS.
- A SCRIPT BASED CREW ACTION UNDERSTANDING PROGRAM
- MODELS PROCEDURAL ACTIONS
- INFERS PILOT'S CURRENT GOALS, PLANS AND PROCEDURES
- DETECTS OMITTED, INCORRECT AND OUT-OF-ORDER ACTIONS

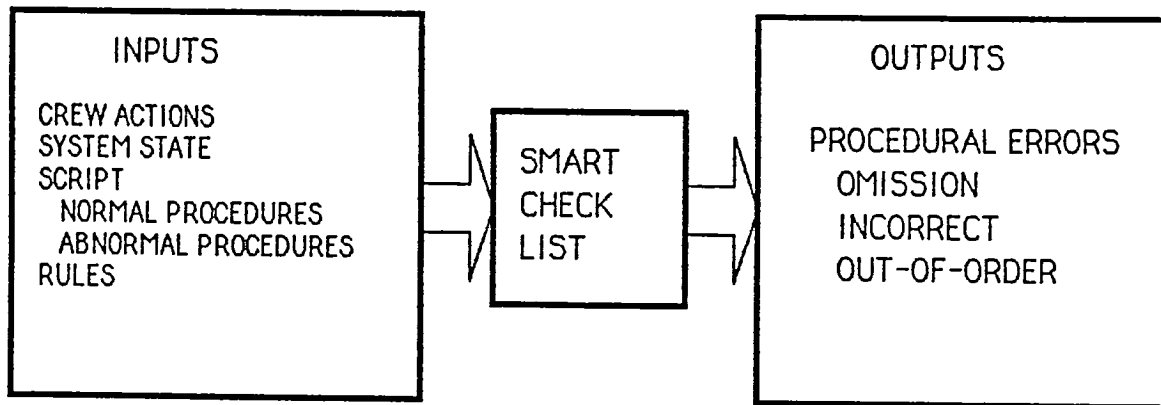

APPLICATIONS

- FULL MISSION DATA ANALYSIS
- ERROR TOLERANT COCKPITS
- ERROR TOLERANT WORK STATIONS

SPACE STATION HUMAN FACTORS RESEARCH REVIEW

December 6, 1985

INHOUSE ADVANCED DEVELOPMENT AND RESEARCH

Chaired by: Trieve Tanner

I wish to extend my acknowledgements to the following people:

- **all of the speakers**
- **chairpeople: Vic Vykukal, Yvonne Clearwater, and Marc Cohen**
- **various support people, whom I have already thanked**
- **Marc Cohen again for coordinating the overall planning**
- **the AV support people**
- **Kathleen Connell, who coordinated the logistics**



Report Documentation Page

1. Report No. NASA CP-2426	2. Government Accession No.	3. Recipient's Catalog No.	
4. Title and Subtitle Space Station Human Factors Research Review. Volume IV: Inhouse Advanced Development and Research		5. Report Date May 1988	6. Performing Organization Code
		7. Editors Trieve Tanner, Yvonne A. Clearwater, and Marc M. Cohen, Editors	8. Performing Organization Report No. A-87247
9. Performing Organization Name and Address Ames Research Center Moffett Field, CA 94035		10. Work Unit No. 482-52-21-01	11. Contract or Grant No.
		13. Type of Report and Period Covered Conference Publication	
12. Sponsoring Agency Name and Address National Aeronautics and Space Administration Washington, DC 20546-0001		14. Sponsoring Agency Code	
		15. Supplementary Notes Point of Contact: Yvonne A. Clearwater, Ames Research Center, Mail Stop 293-2, Moffett Field, CA 94035, (415)694-5937 or FTS 464-5937	
16. Abstract <p>The presentations on the final day of the Research Review focused on Inhouse Advanced Development and Research. A variety of Space Station human factors studies conducted by NASA Ames ASHFRD personnel are presented, including: (1) Cognition and Perception Issues – Image Management, Space Station Proximity Operations and Windows and Prox-Ops Perspective Display: Spatial Displays-VERT; (2) Workload and Performance Issues – Space Suit Workload Experiment, RMS Workload Prediction/Assessment, and Cursor Control in Zero-G (Flight Experiment); (3) Human/Machine Integration Issues – Spatial Cognition, Virtual Environment, Fault Diagnostics, Error Tolerance/Procedure Aids.</p>			
17. Key Words (Suggested by Author(s)) Image management, Spatial cognition windows, Virtual environment, Prox-Ops, Fault diagnostics, Human performance, Workload, Error tolerance, Cursor control		18. Distribution Statement Unlimited – Unclassified Subject Category – 51	
19. Security Classif. (of this report) Unclassified	20. Security Classif. (of this page) Unclassified	21. No. of pages 136	22. Price A07

National Aeronautics and
Space Administration
Code NTT-4

Washington, D.C.
20546-0001

Official Business
Penalty for Private Use, \$300

SPECIAL FOURTH-CLASS RATE
POSTAGE & FEES PAID
NASA
Permit No. G-27

NASA

**POSTMASTER: If Undeliverable (Section 158
Postal Manual) Do Not Return**
