

ISO/LWS : DETECTOR STATUS

C. Le Naour¹, C. Deleltrez¹, M. Griffin², P. Ade²,
D. Robinson², D. Vickers²

¹ Centre d'Etude Spatiale des Rayonnements,
9, avenue du Colonel Roche - BP 4346 - 31029 Toulouse FRANCE

² Physics Dept. Queen Mary College, Mile End Road,
London E1 4NS ENGLAND

The aim of the long wavelength spectrometer of the Infrared Space Observatory is to perform spectrometry in the wavelength range 45 to 200 μ m using two resolution modes. The resolution will be around 200 in the medium resolution mode while it will reach 10^4 in the high resolution mode. The sensitivity of this instrument will be close to 10^{-18} W/Hz.

A schematic view of the focal plane unit is presented in figure 1. The input beam comes from the pyramidal mirror. The beam is collimated by a large mirror assembly. However, mirror 2 restricts the field of view to an opening of 1.65 arc minutes. In the medium resolution mode the beam goes directly to the diffraction grating while in the high resolution mode it passes through a Fabry-Perot interferometer mounted on a wheel in front of the grating. The diffracted radiation from the grating is collected by a spherical mirror and brought to a focus along a line matching the surface of the detector assembly. The temperature of the optics will be 3 K while the detectors will be cooled to 1.8 K.

The detectors divide the wavelength range into ten spectral channels. The spectral range and position of each detector will be as indicated in figure 2. Each detector will cover approximately a spectral bandwidth sufficient to allow for a 50 % redundancy in the case of detector failure. There are three types of detectors. SW1 is a Ge:Be photoconductor covering the 45-55 μ m region. LW1, SW2, SW3, SW4, SW5 are unstressed Ge:Ga photoconductors which cover the 50 to 120 μ m region. LW2, LW3, LW4, LW5 are uniaxially stressed Ge:Ga photoconductors covering the range from 100 to 200 μ m. The stress applied to each detector will be adjusted in order to get the peak response in the corresponding wavelength range, and to minimize the dark current of the shorter wavelength stressed detectors. Stressed and unstressed detectors are located alternatively in order to receive the first and second

order of the diffracted beam. In the medium resolution mode the ten detectors are used simultaneously while in the high resolution mode only one detector is used. Response curves for prototype stressed and unstressed Ge:Ga photoconductors are shown in figure 3 together with the usable wavelength ranges allowed for each type. In order to limit the spectral range of the incident beam a bandpass filter will be used with each detector. This will be a metal mesh filter consisting of a combination of about five grids made by photolithographic process. Very narrow spectral passbands can be achieved, as illustrated by the 160 μ m filter profile shown in figure 4. In addition to the bandpass filter, a blocking filter will be used to reject the near IR radiation.

Figure 5 presents a schematic view of an unstressed detector mounting unit. The filter assembly is placed at the aperture of a parabolic light concentrator used to limit the field of view of each detector. The unstressed detector glued on a sapphire support is placed in a spherical integrating cavity in order to increase its effective absorption efficiency. A set of two feedthroughs is used to connect the detector contacts with the external wires. This reduces dramatically the light leakage at the detector.

In figure 6 a schematic drawing of a stressed detector mounting unit is presented. The detector is mounted between two pieces of sapphire and stressed with a screw over a ball. The overall stress system is 9.6 mm long and has a diameter of 3 mm. Detector mount is typically 26.2 mm long, 16.9 mm high and 6.7 mm in width. The detectors are mounted on a bar which is coupled strongly to the superfluid helium tank in order to operate the detectors at a temperature of 1.85 K. The detector assembly is shown in figure 7. To calibrate the detectors during the flight five infrared sources are placed in front of the detector assembly. These sources are mounted on the sidewall of the instrument. Figure 8 shows how they are placed with respect to the principal beam.

The currents from the detectors are collected by ten individual integrating amplifiers (Infrared Labs model JF4) mounted in T05 cans. They are placed in holes built into the detector support frame behind the detector block as shown in figure 7. The JF4 circuit is presented in figure 9. It consists of 3 Si JFETS. The photocurrent is integrated on the 7.5 pF gate capacitance of the JFET1. The resulting voltage is transmitted to the output by the JFET1 mounted in a follower configuration. The input is set to zero by the "reset and compensation process". Figure 10 shows a functional diagram of the warm analogue processing unit for the detector subsystem. The output voltage of the IA is amplified and AC coupled. It is then sampled at around 100 Hz and finally converted into a digital signal.

The integrating amplifier has been chosen to avoid the limitation by Johnson noise of the feedback resistor that is encountered in the transimpedance amplifier configuration. Moreover if the detector is noiseless the signal to noise ratio is improved at a rate $(t)^{3/2}$ faster than $(t)^{1/2}$ obtained in TIA configuration, where t is integration time. The detector dark current is a very critical feature and in the IA configuration must be reduced to a very low level. Originally, it was intended to operate the unstressed detectors at 3 K and the stressed detectors at 2 K, with TIA readout electronics. However, reducing the operating temperature of all the detectors to 1.85 K results in a dramatic reduction in the dark current. In the first base line the unstressed detectors were cooled down to 3 K and the temperature of the stressed detectors was 2 K. Reducing the temperature to 1.85 K for all of the 10 detectors permits to decrease the dark currents by one order of magnitude. This is shown in figure 11 for the unstressed prototype. The prototype is a cube of 1.4 mm base length biased with 350 mV while its breakdown voltage is around 500 mV. At 1.85 K the dark current reaches 300 e/s.

The variation of the dark current with temperature for the stressed prototype is shown in figure 12. The stressed detector is also a cube of 1.4 mm base length. The bias voltage is equal to 100 mV while the breakdown voltage is around 150 mV. At 1.85 K the dark current of the stressed prototype approaches 10^4 e/s.

With the reduction of the temperature no significant difference in sensitivity for the unstressed detector has been measured. On the other hand, the signal to noise ratio of the stressed detector is improved as the temperature decreases. This is shown in figure 13 where the variation of the normalized responsivity and the normalized square root of the dark current are plotted as a function of the temperature. Assuming that the noise is limited by the dark current shot noise, it decreases more rapidly than the responsivity. In these operating conditions the performances of the Gallium doped Germanium detector prototype are as follows : the responsivities reach 3A/W for the unstressed detector and 5A/W for the stressed one. The Noise Equivalent Powers approach 10^{-18} W/ $\sqrt{\text{Hz}}$ for the unstressed detector and a few 10^{-18} W/ $\sqrt{\text{Hz}}$ for the stressed one.

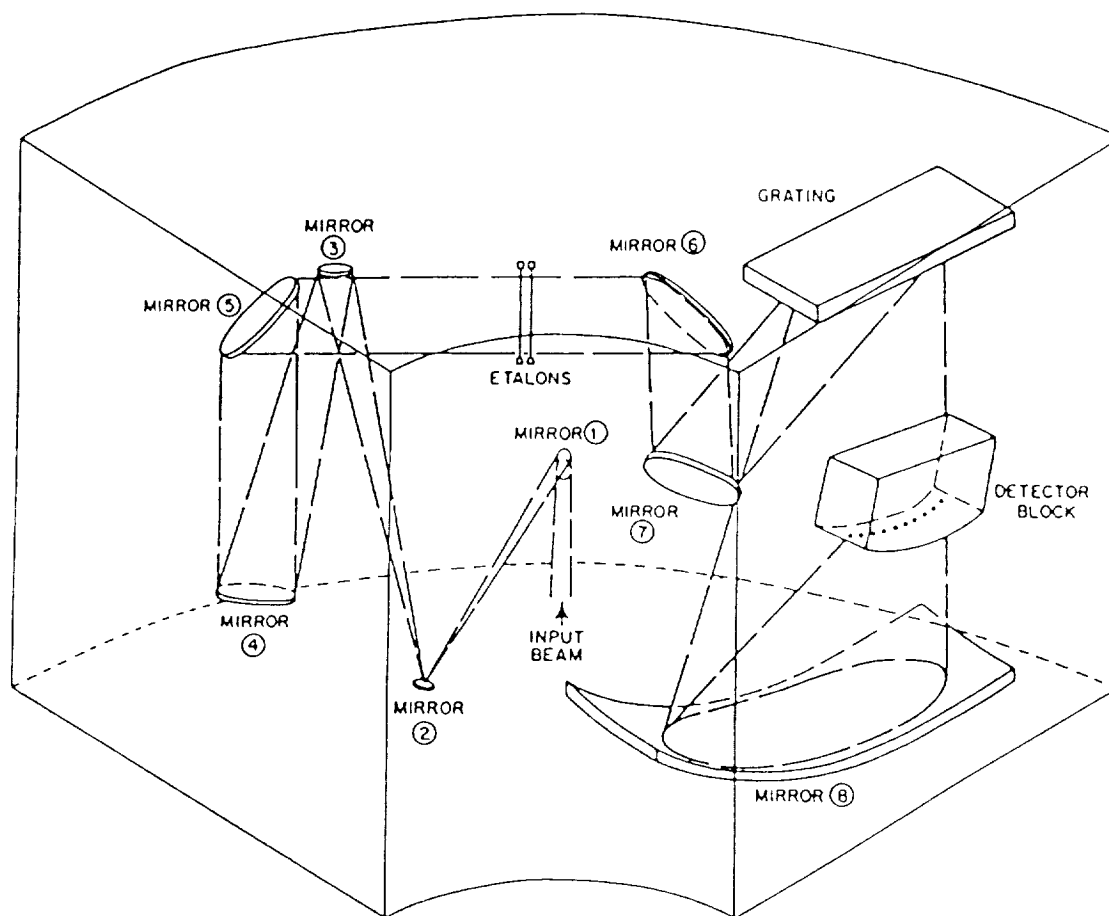

Schematic of LWS

FIGURE 1

DETECTOR	TYPE	NORMAL RANGE	USABLE RANGE
SW1	Ge:Be.u	45 - 50 μm	45 - 55 μm
LW1	Ge:Ga.u	90 - 110 μm	80 - 120 μm
SW2	Ge:Ga.u	50 - 60 μm	50 - 65 μm
LW2	Ge:Ga.s	110 - 130 μm	100 - 140 μm
SW3	Ge:Ga.u	60 - 70 μm	55 - 75 μm
LW3	Ge:Ga.s	130 - 150 μm	120 - 160 μm
SW4	Ge:Ga.u	70 - 80 μm	65 - 85 μm
LW4	Ge:Ga.s	150 - 170 μm	140 - 180 μm
SW5	Ge:Ga.u	80 - 90 μm	75 - 95 μm
LW5	Ge:Ga.s	170 - 180 μm	160 - 200 μm

"U" IS UNSTRESSED AND "S" STRESSED

FIGURE 2

SPECTRAL RANGE AND POSITION OF THE DETECTORS

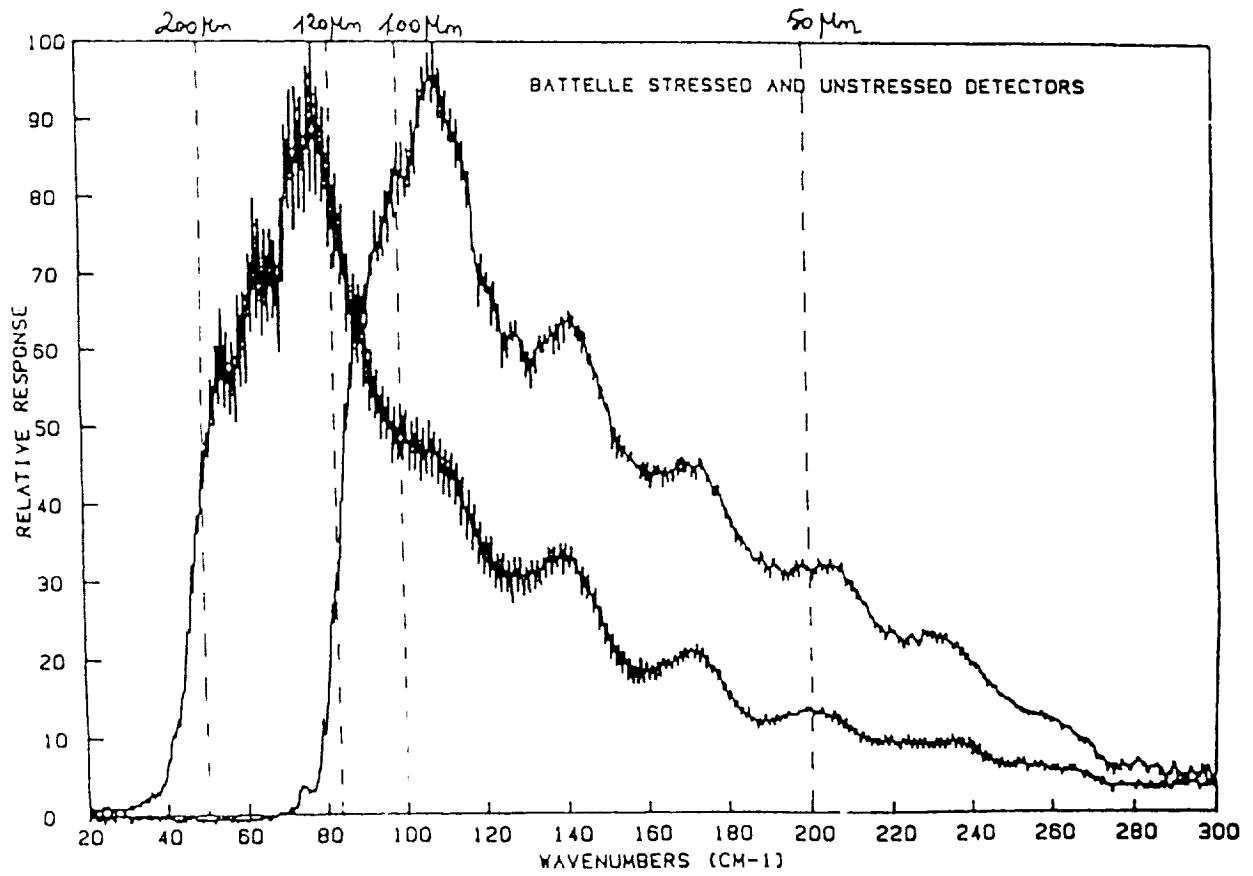

FIGURE 3

SPECTRAL RESPONSES OF STRESSED AND UNSTRESSED Ge:Ga PHOTOCONDUCTORS

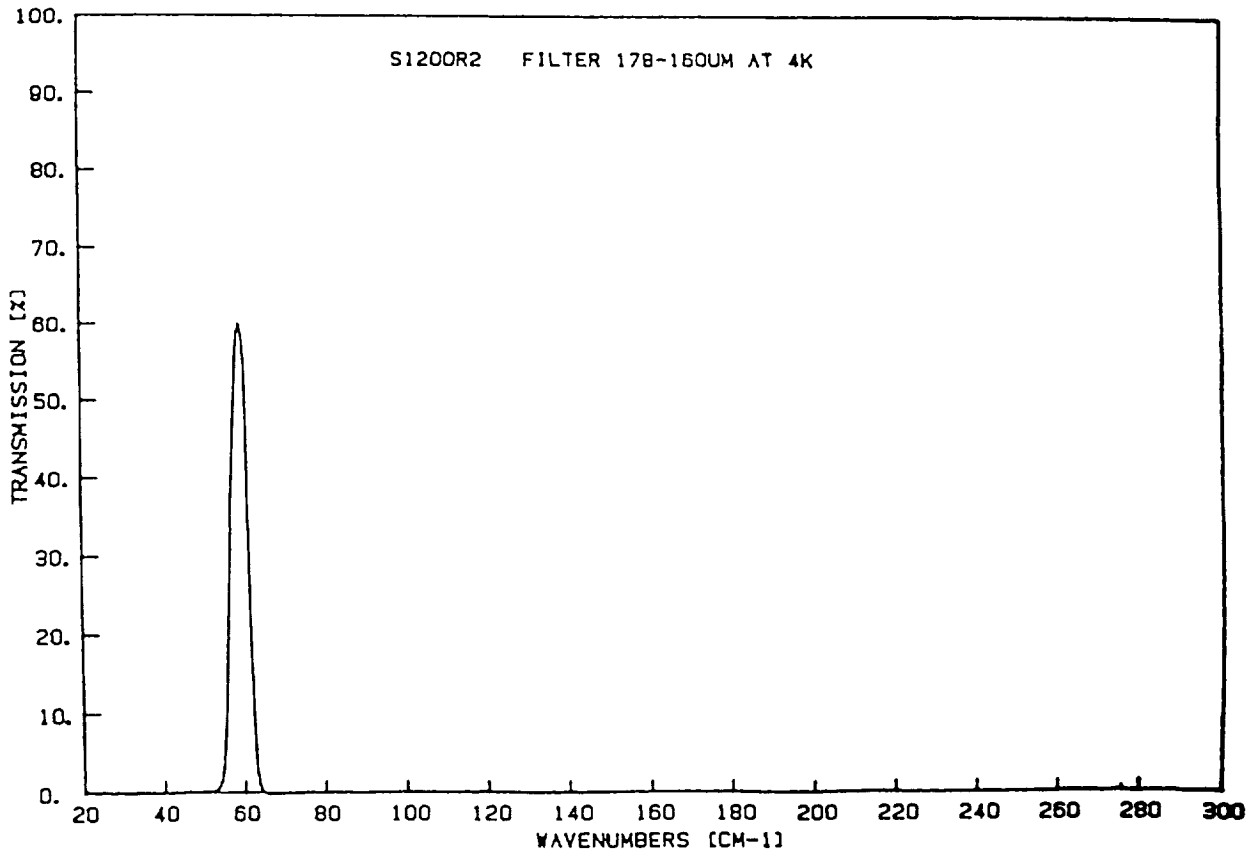

FIGURE 4

MEASURED FILTER RESPONSE

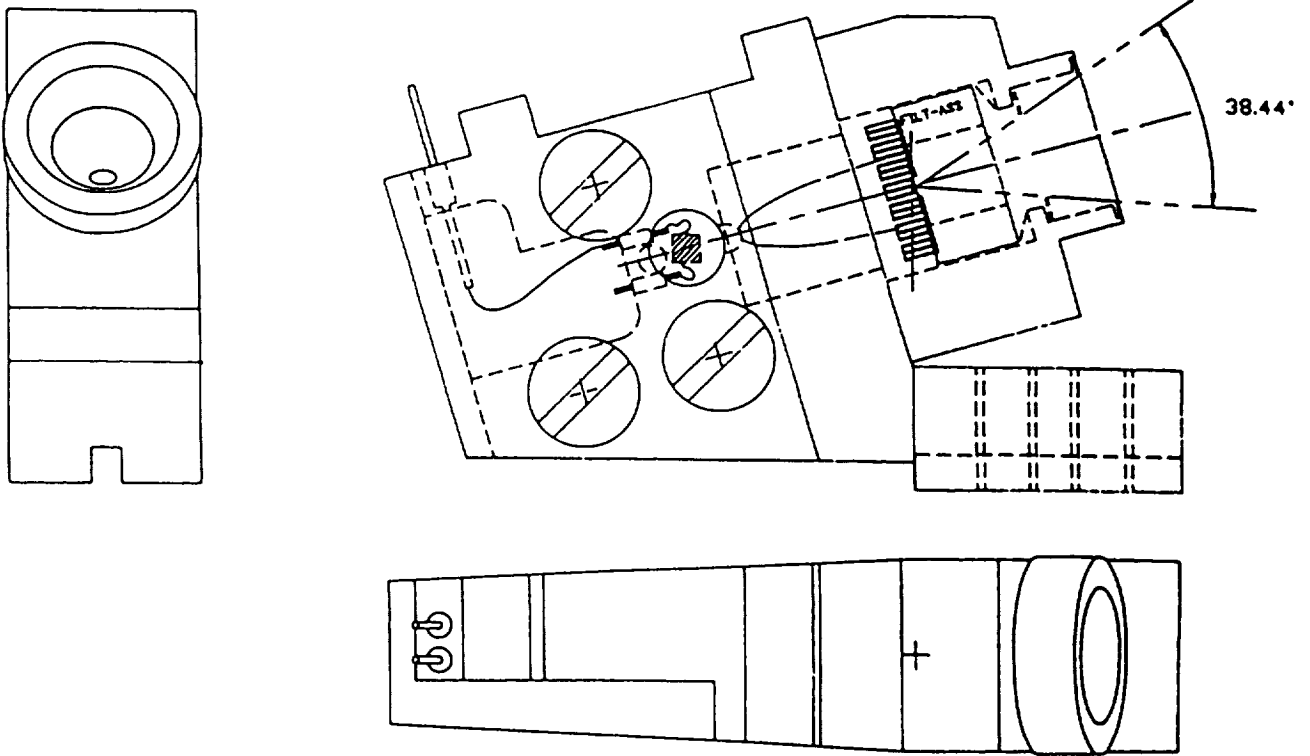

FIGURE 5

UNSTRESSED DETECTOR MOUNTING UNIT

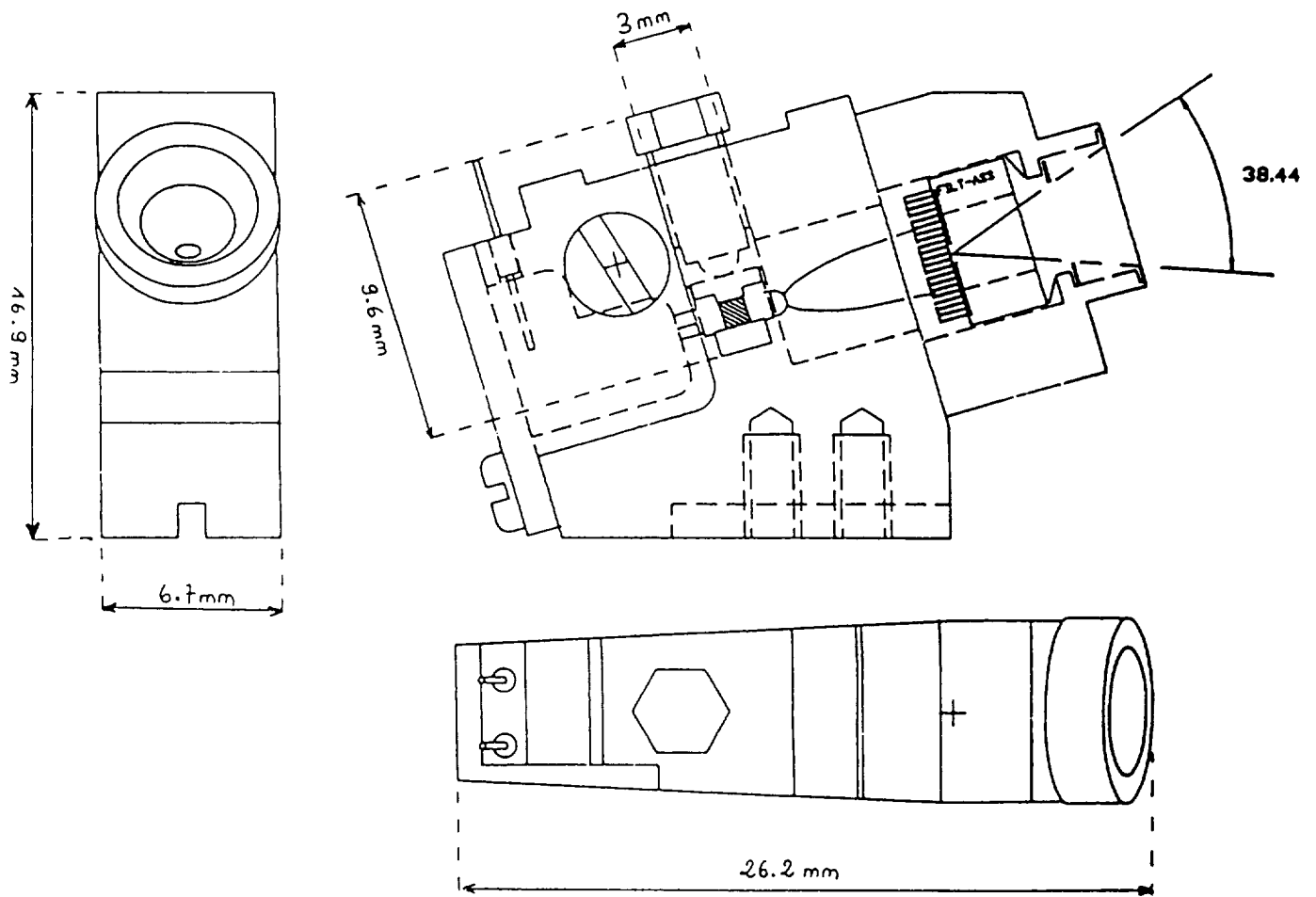

FIGURE 6

STRESSED DETECTOR MOUNTING UNIT

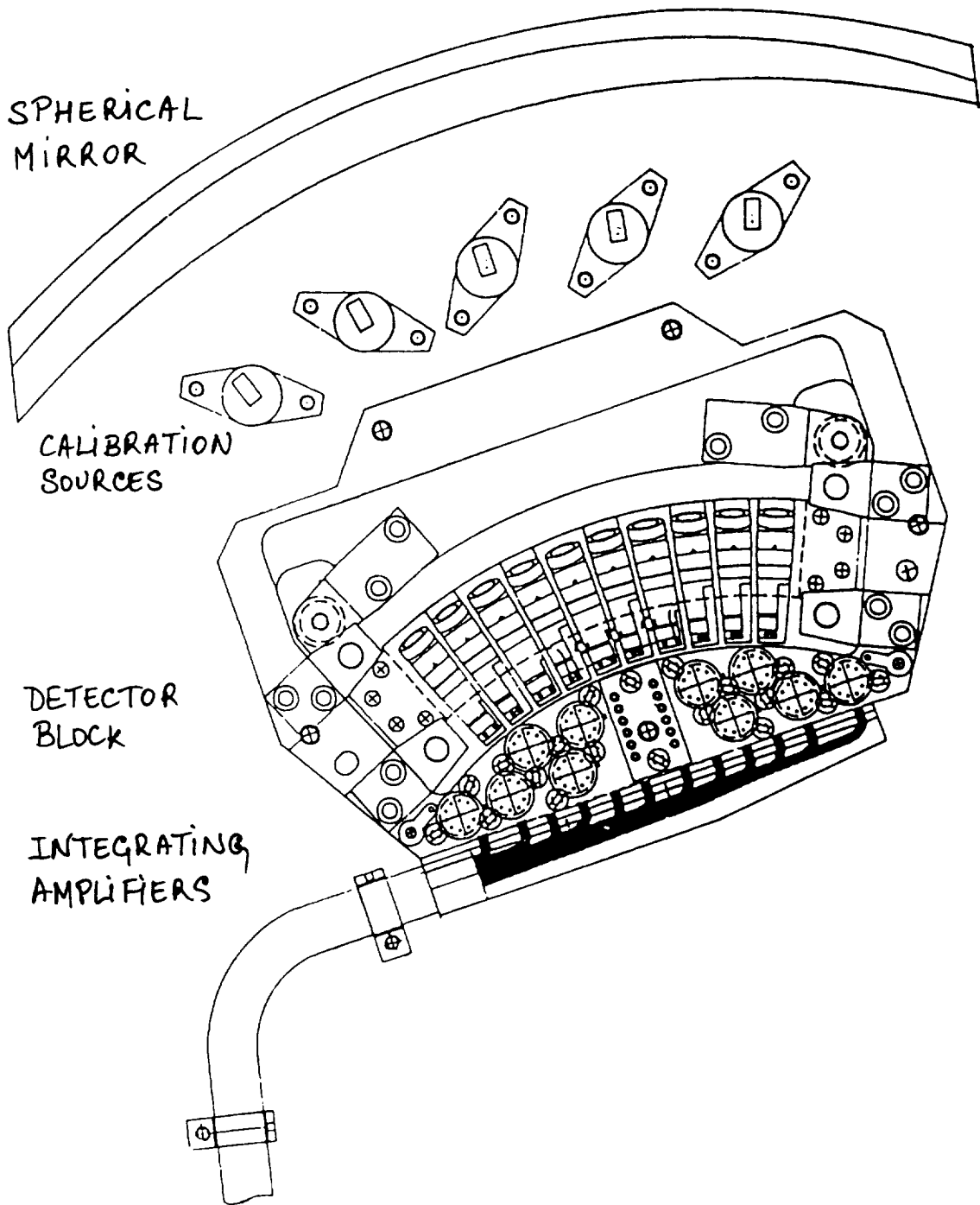
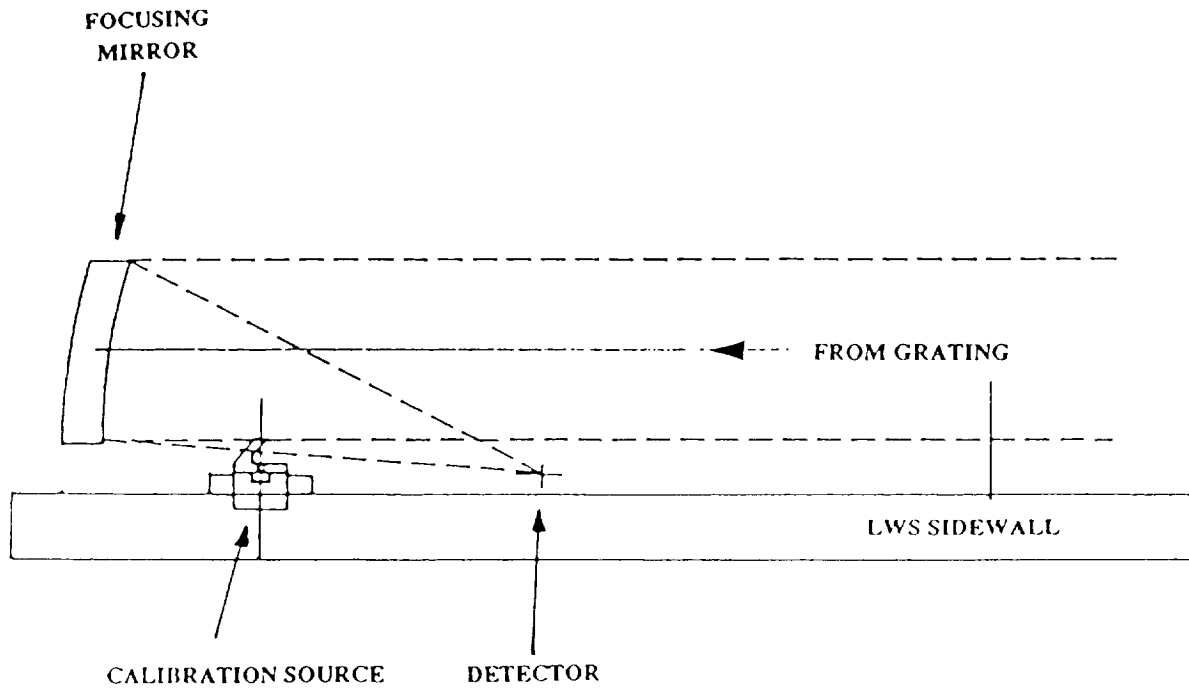

FIGURE 7



DETECTOR INFRARED CALIBRATION SOURCES (SCHEMATIC)

FIGURE 8

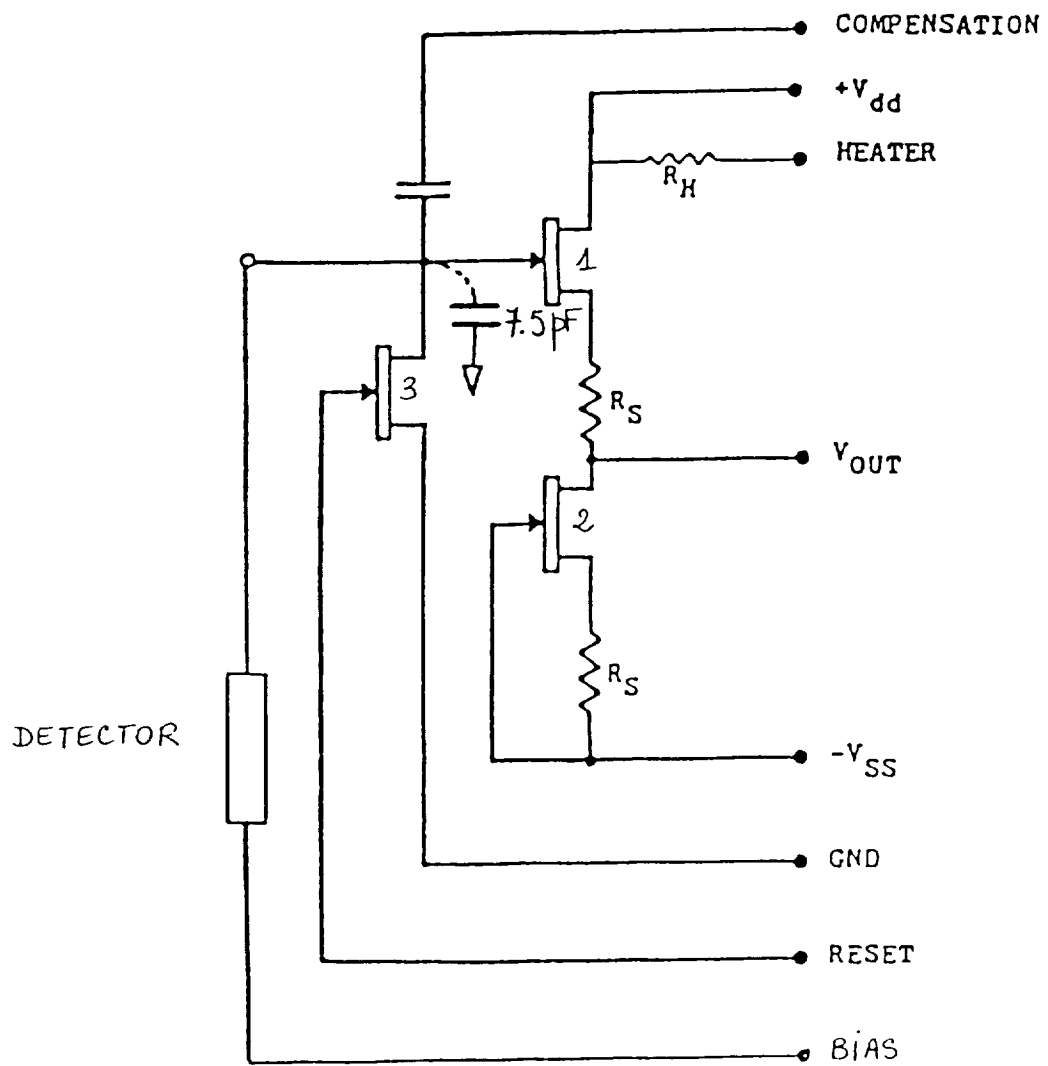

FIGURE 9

JF4 CIRCUIT

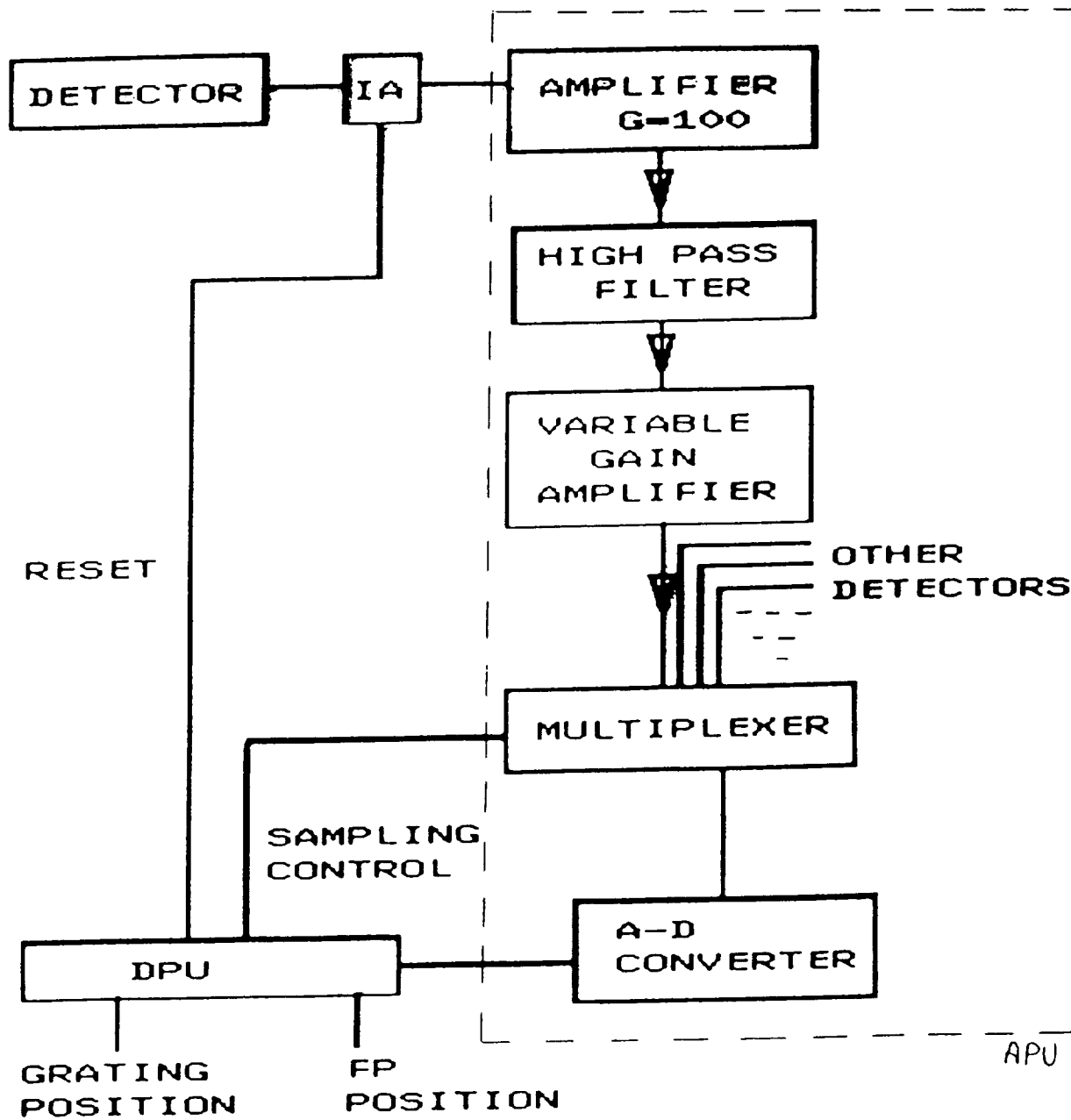

FIGURE 10

SIGNAL PROCESSING

Dark current Versus Temperature for
Unstressed Prototype

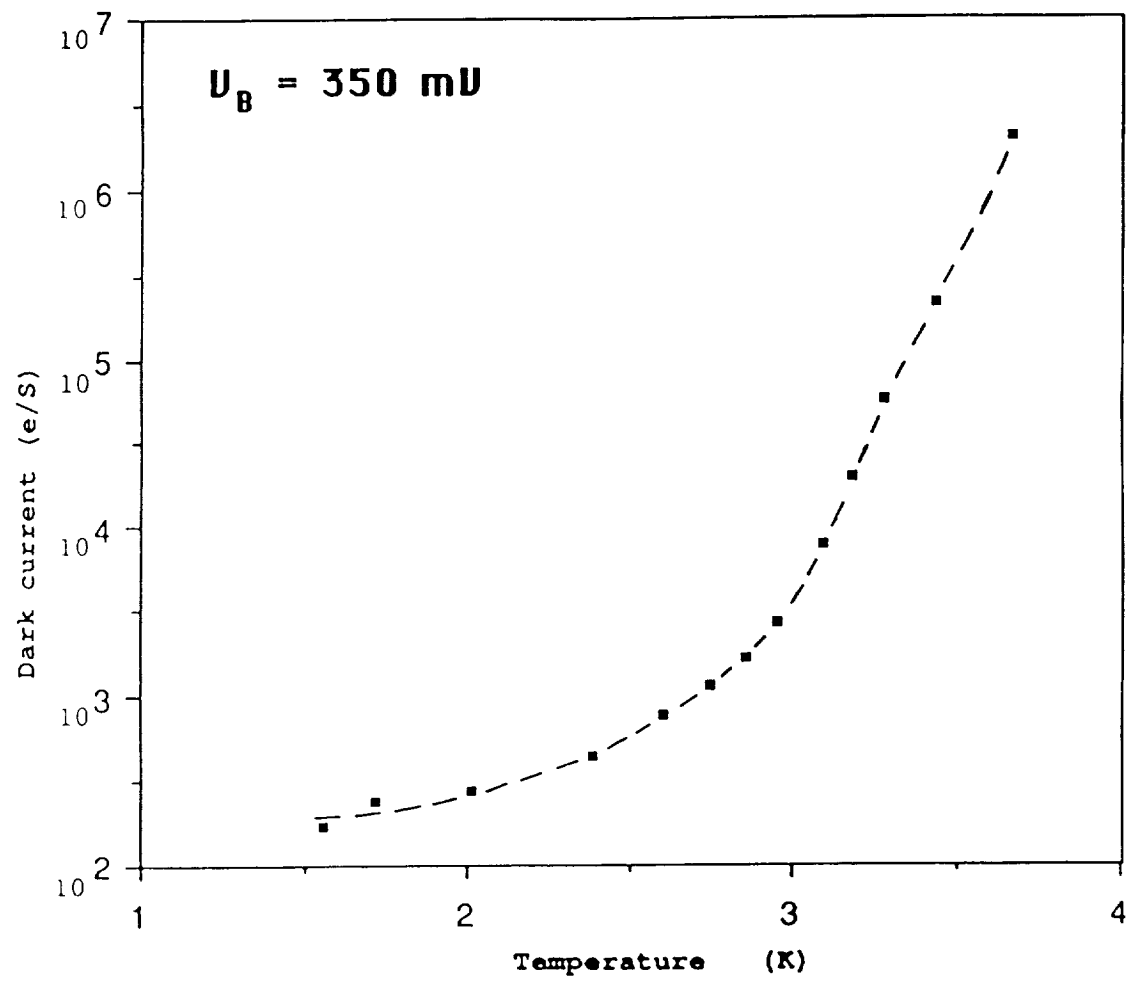

FIGURE 11

Dark current Versus Temperature for
1.4 mm Stressed $g_e : g_o$ Prototype

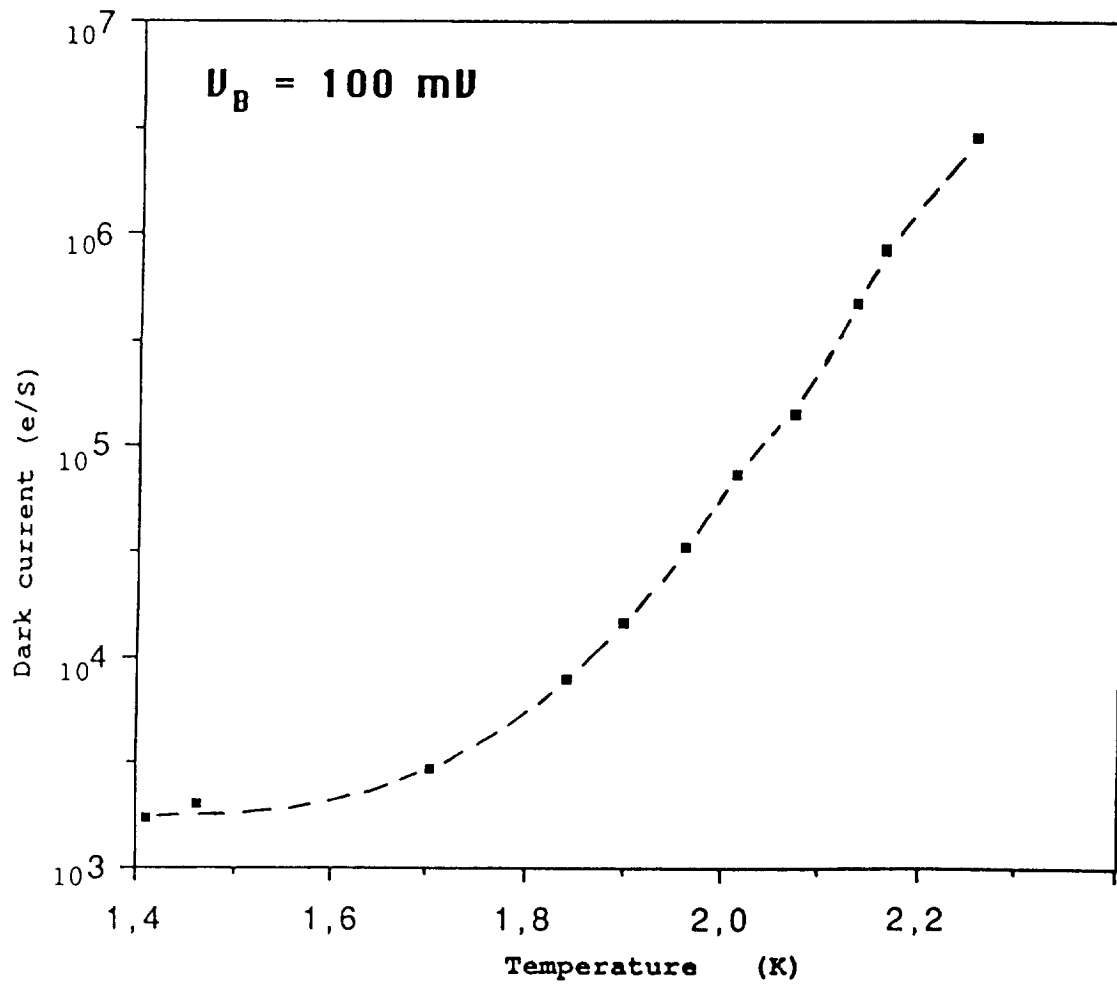

FIGURE 12

Normalised Responsivity and Dark
current Versus Temperature for 1.4 mm
Stressed Prototype

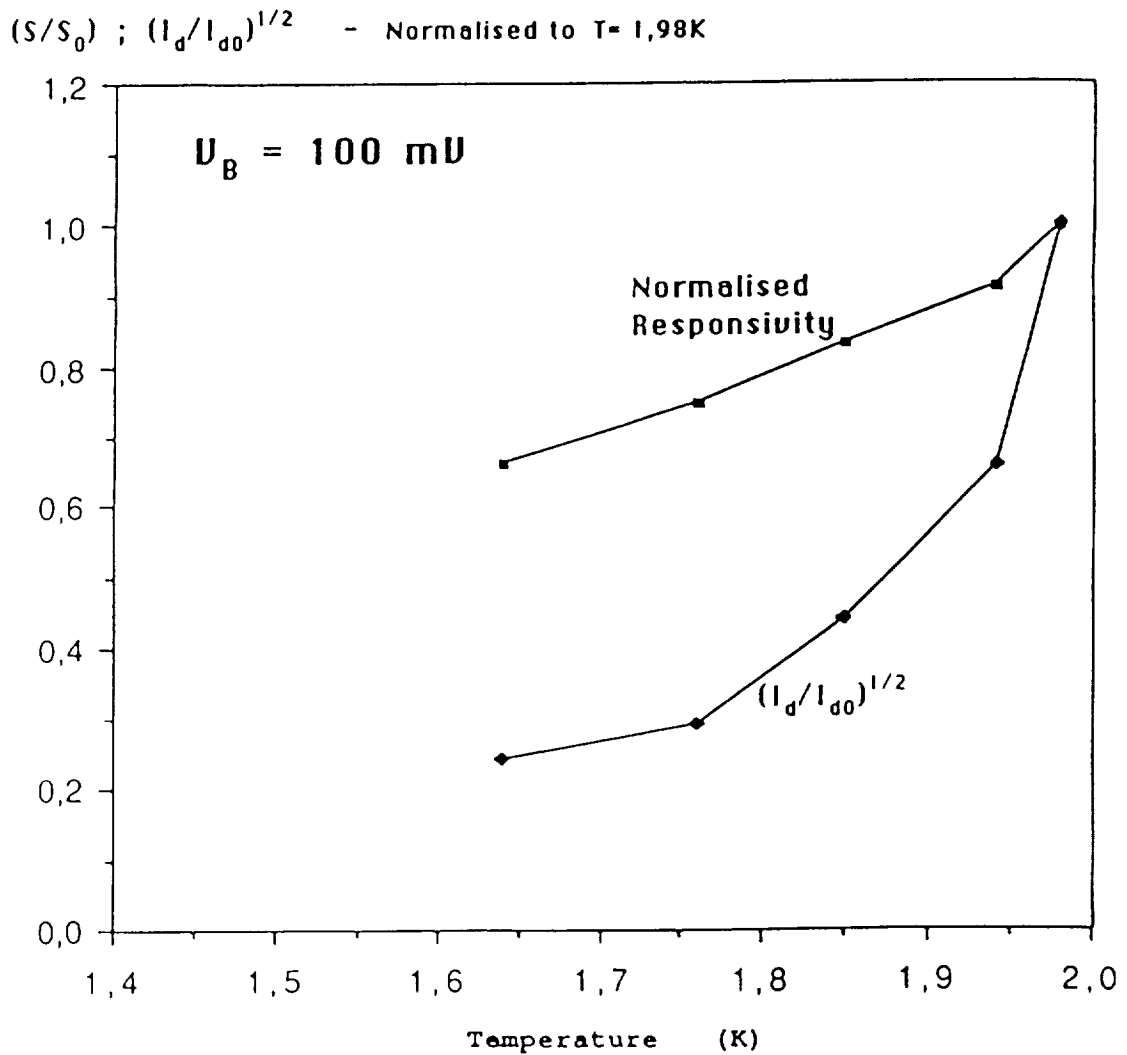

FIGURE 13