

512-13

A Reproduced Copy OF

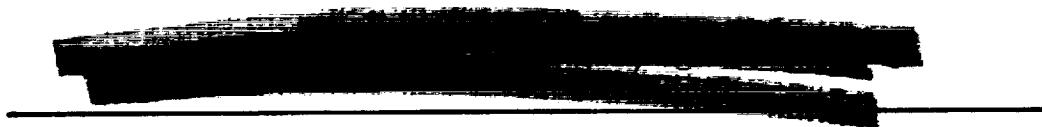

Reproduced for NASA

by the

NASA Scientific and Technical Information Facility

(NASA-CR-171944) THE DESIGN AND FABRICATION
OF THE CENTAUR NEUTRAL BUOYANCY TRAINER AND
RELATED HARDWARE Final Report (Essex Corp.)
74 p CSCL 14B

N91-10085

Unclas
0310410

G3/09





CR-171 944

FINAL REPORT

THE DESIGN AND FABRICATION OF
THE CENTAUR NEUTRAL BUOYANCY TRAINER
AND RELATED HARDWARE

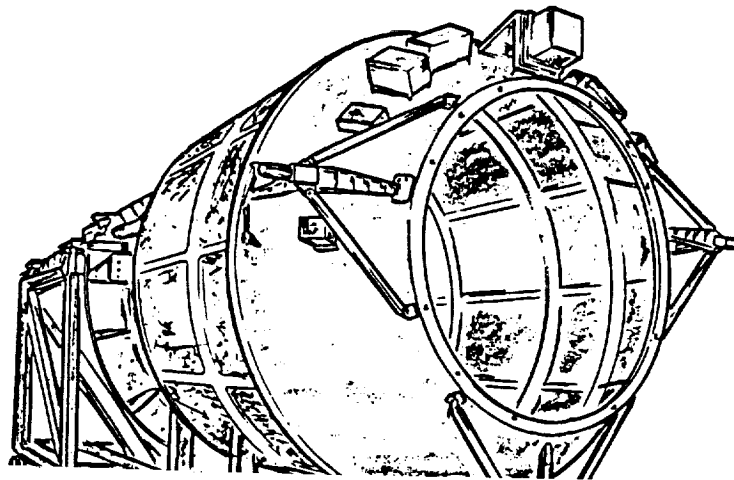

CONTRACT NAS9-17325

APRIL 5, 1986

ESSEX REPORT NO. H-86-04

FINAL REPORT

THE DESIGN AND FABRICATION OF THE CENTAUR NEUTRAL BUOYANCY TRAINER
AND RELATED HARDWARE

Contract NAS9-17325

Prepared For:

NATIONAL AERONAUTICS AND SPACE ADMINISTRATION
Johnson Space Center
Houston, Texas 77058

Prepared By:

Alan S. Ware
Michael Hollingsworth
ESSEX CORPORATION
690 Discovery Drive
Huntsville, Alabama 35806

April 5, 1986

H-86-04

FOREWORD

This report describes the results of a 14-month contract effort by Essex Corporation for NASA's Johnson Space Center. During the performance of the contract tasks, Essex designed, fabricated and delivered two full-scale mockups of the Centaur upper stage. One was the Centaur WETF Trainer and the other was the Centaur 1-G mockup

Throughout the contract Mr. Harmon Roberts, SP32, provided technical direction, guidance and support. His efforts in acquiring drawings and other technical information contributed to the success of the project and are greatly appreciated.

Any questions about the Centaur mockup project should be addressed to Mr. Roberts at (713) 483-6313 or Mr. Alan Ware at (205) 837-2046.

TABLE OF CONTENTS

	<u>Page</u>
FOREWORD	1
LIST OF FIGURES	iii
LIST OF ACRONYMS	iv
1.0 INTRODUCTION	1
1.1 Background	1
1.2 Scope	1
2.0 TECHNICAL APPROACH	2
2.1 Centaur WETF Crew Trainer	2
2.1.1 Basic Description	2
2.1.2 Assembly (G-Prime and G-Version)	2
2.1.3 Engineering Analysis	2
2.2 Mechanical Mechanisms	4
2.2.1 Spring Rate Mechanism	3
2.2.2 Locking Pin Assembly	8
2.2.3 EVA Linkage	8
2.3 High-Fidelity Box Add-On	10
2.3.1 Introduction	10
2.3.2 Locations and Description of Work Done	10
2.4 Centaur 1-G Mockup	14
2.5 Documentation	14
3.0 CONTRACT PERFORMANCE	15
3.1 Milestone Schedule	15
3.2 Expenditure Chart	16
APPENDIX A - Centaur WETF Operations and Maintenance Manual	A-1
APPENDIX B - Patel Engineering Analysis of WETF Centaur	B-1
APPENDIX C - Centaur 1-G Operations and Maintenance Manual	C-1
APPENDIX D - Centaur Drawing List	D-1

LIST OF FIGURES

	<u>Page</u>
Figure 1: Centaur Trainer G-Prime and G-Versions	3
Figure 2: Rotator Torque - Actual vs. Trainer Simulation	5
Figure 3: Spring Rate Simulation Mechanism Operation	6
Figure 4: Locking Pin Assembly	9
Figure 5: EVA Linkage	11
Figure 6: Locations of High-Fidelity Boxes	12
Figure 7: Expenditure Chart	

LIST OF ACRONYMS

CDU	Control Distribution Unit
CSS	Centaur Support Structure
EVA	Extravehicular Activity
JSC	Johnson Space Center
PICU	Pyro Initiator Control Unit
PILU	Propellant Indicator Level Unit
WETF	Weightless Environment Training Facility

1.0 INTRODUCTION

1.1 Background

The Centaur upper stage booster is destined to carry the spacecraft Galileo to Jupiter, and the spacecraft Ulysses to an orbit around the sun after launch from the Space Shuttle. The flight vehicle has several Extravehicular Activity (EVA) contingency tasks that require crew training. This need for crew training generated the requirement for the Centaur Weightless Environment Training Facility (WETF) crew trainer, which is high fidelity in areas of expected crew interface.

During the production of the Centaur WETF crew trainer, the need for a jumper cable from Centaur to the Orbiter was identified. This EVA contingency task would be the installation of a cable from the Orbiter cargo bay sill to various command data boxes on Centaur to allow crew control of deployment should a failure occur. This task required the upgrading of volumetric boxes on the trainer to a high-fidelity configuration including electrical connector installation and cable routing.

The need for a 1-G representation of Centaur produced the additional contract requirement for a second mockup. Its construction is similar to the WETF version with the appropriate changes based on 1-G use.

1.2 Scope

In developing the original and modified contract end items, Essex provided the items listed below:

- o Centaur WETF crew trainer
- o High-fidelity box and cabling upgrade on PICU, PILU, Rotators, and CDUs
- o Centaur 1-G mockup
- o Documentation.

These items are described in more detail in the following sections.

2.0 TECHNICAL APPROACH

2.1 Centaur WETF Crew Trainer

2.1.1 Basic Description

The Centaur Crew Trainer accurately represents the flight vehicle. The Centaur Support Structure (CSS) is constructed out of 1/4 in. and 3/8 in. 5052 and 6061 aluminum plate welded together in segments and bolted together. The rest of the vehicle is cylindrical and conical in shape. It has 1/4 in. x 4 in. ring sections which act as bulkheads and bolt faces for assembly. A 4 in. rolled plate is welded to the rings to create a 4 in. x 4 in. fabricated angle. These bulkhead assemblies are connected with 3 in. wide, 1/4 in. thick, tee beam runners. The assembled sections are skinned with 1/8 in. thick expanded aluminum sheet. The forward conical section is skinned with .060 in. aluminum sheet.

2.1.2 Assembly (G-Prime and G-Version)

The Centaur Trainer can be assembled in both the longer G-prime version and the shorter G-version. The trainer is sectioned such that some pieces are removed and some are exchanged from G-prime to G (Figure 1). Assembly is detailed in the Centaur WETF Operations and Maintenance Manual (Appendix A) which was delivered to WETF personnel at the time of the Trainer's delivery.

2.1.3 Engineering Analysis

A structural integrity analysis as well as lifting point/lifting scheme analysis was performed per contract requirements. The analysis was performed for Essex by Patel Engineering (Appendix B). The Trainer successfully passed the analysis.

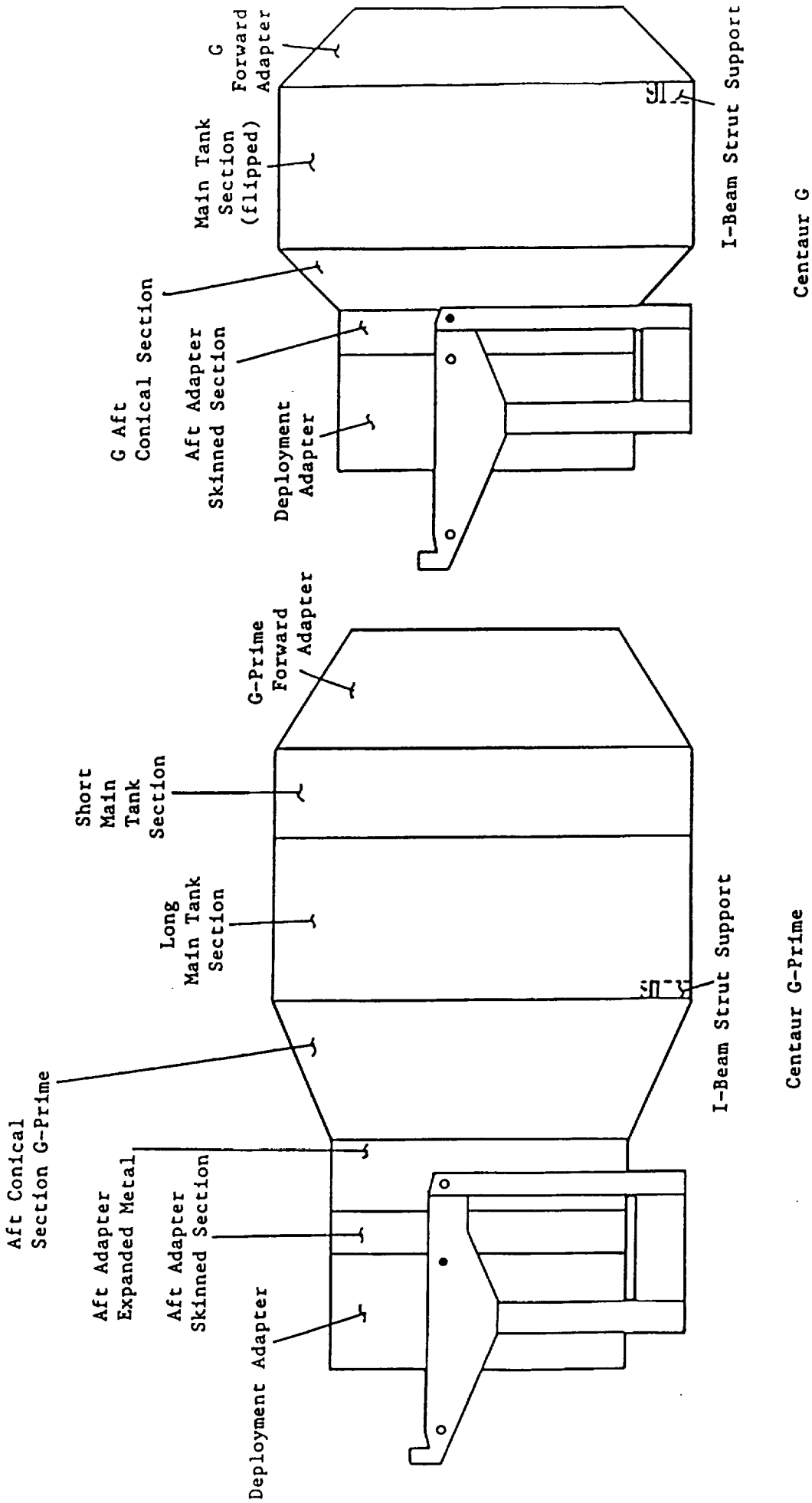

Figure 1: Centaur Trainer G-Prime and G-Versions

2.2 Mechanical Mechanisms

2.2.1 Spring Rate Mechanism

2.2.1.1 Introduction

The flight vehicle, during its rotation from the cargo bay, pivots and flexes feed ducts and electrical cabling. These flexing and pivoting members impart resistance forces which vary depending upon what degree of rotation is reached. The Centaur Trainer has a spring system which is set up to simulate these resistance forces, so that they may be encountered by the EVA crewmember on the contingency restowing of the vehicle in the cargo bay.

2.2.1.2 Explanation of Operation

Two spring rate mechanisms were used, one on each side to provide equal force on the Trainer and to reduce the size of the springs used.

By using compression and extension springs the torque required to stow Centaur was simulated. A linear reading is represented on the graph (Figure 2). The solid line represents actual torque on the flight vehicle; the simulated torque provided by the mechanism is represented by the broken line.

Because portions of Centaur are not completely submersed until 19 degrees elevation, it was decided to separate the mockup at the separation plane. This allowed the Deployment Adapter the full movement from launch position to stowed position underwater.

Step 1 (Figure 3) shows how the mechanism operates from 45 degrees to 35 degrees; free movement is needed. With the Deployment Adapter neutralized in the 45 degree position, the compression spring shaft stop is 2.09 in. away from the compression spring. As the Deployment Adapter rotates down, the pulley and cable system pulls the spring shaft stop until it hits the compression spring at which point the Deployment Adapter is at 35 degrees.

ROTATOR TORQUE - AVAILABLE/REQUIRED

CENTAUR G

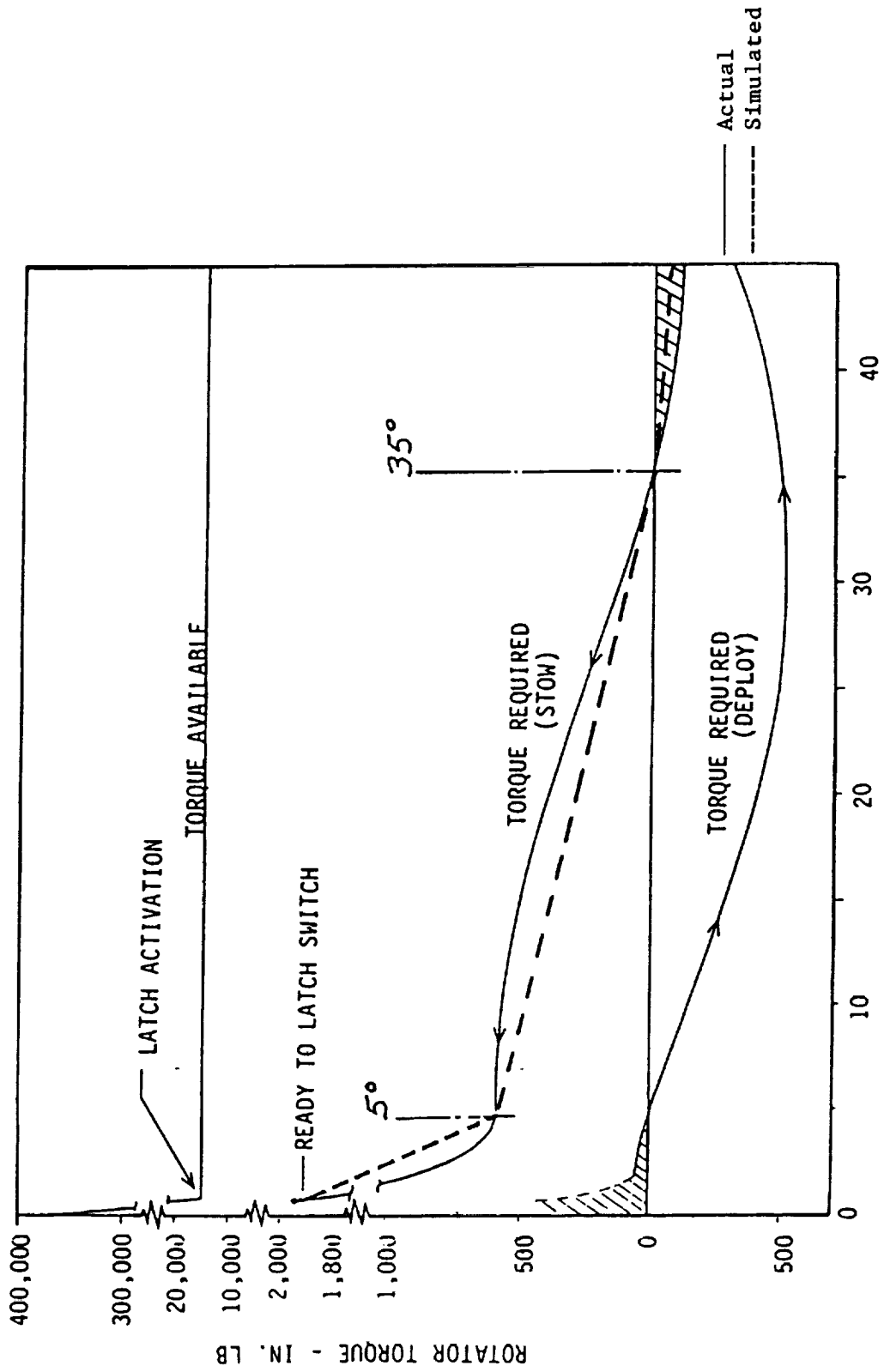
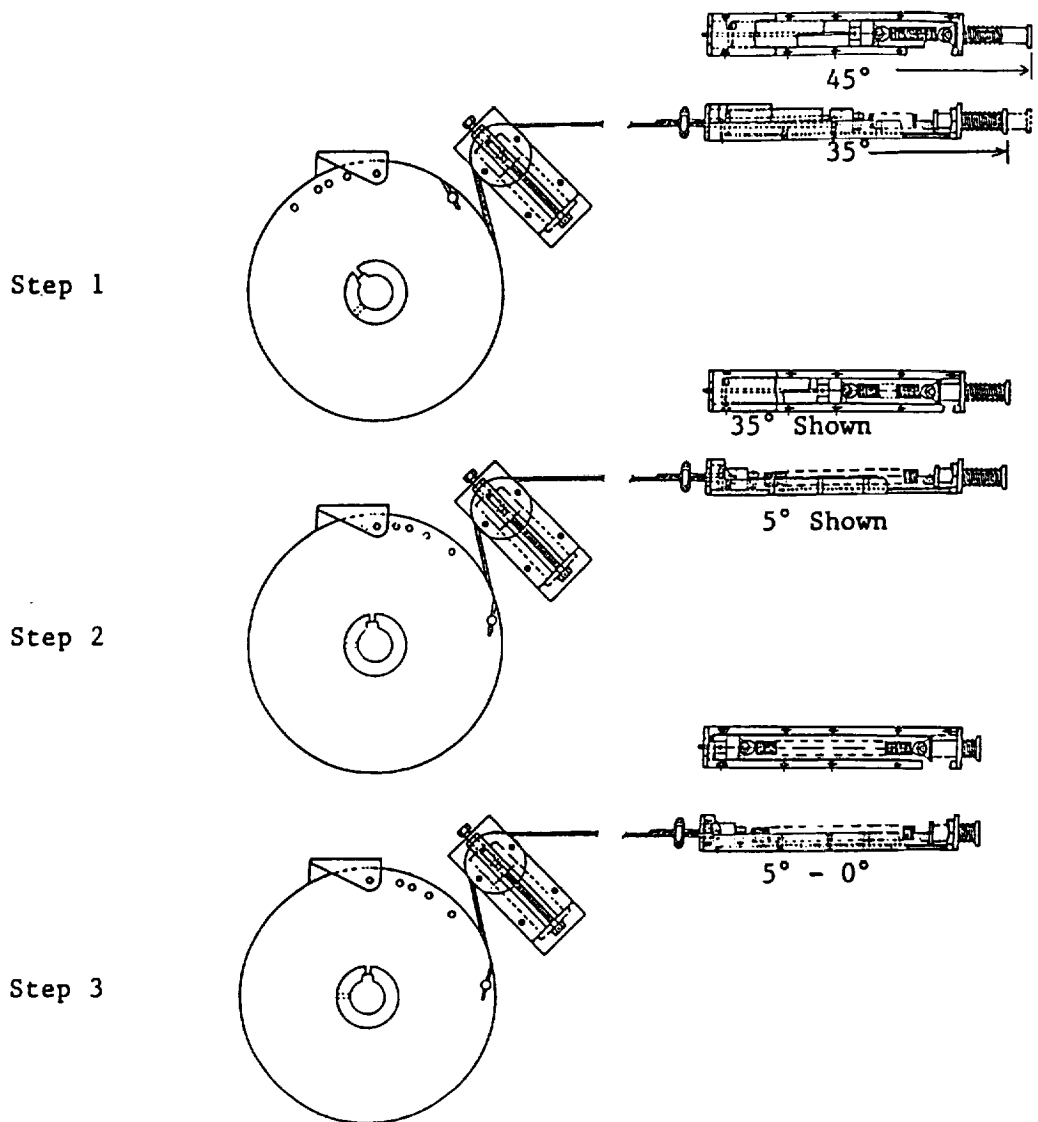

Figure 2: Rotator Torque - Actual vs Trainer Simulation



STEP	DEGREES	LENGTH	SPRING RATE	TYPE SPRING	NO. SPRINGS	
					1	2
1	45°-35°	2.09	Free Movement			
2	35°- 5°	6.28	50 in. lbs.	Ext. Spring	8 in. lbs	4 in. lbs
3	5°- 0°	1.04	108.33 in. lbs.	Com. Spring	104 in. lbs	52 in. lbs

Figure 3: Spring Rate Simulation Mechanism Operation

Step 2 (Figure 3) shows the movement of the mechanism from 35 degrees to 5 degrees. From 35 degrees the interior piston extends the extension spring 6.28 in. to the piston stop. At this point the Deployment Adapter is at the 5 degree position.

Step 3 (Figure 3) shows the final 5 degrees motion of the mechanism. From 5 degrees to 0 degrees, the compression spring outer piston moves 1.04 in. and compresses the compression spring. It should be noted that at this point the added forces of the extension and compression spring provide the simulated forces.

The final latch activation forces were not known at the time of design. It was decided with COR approval to omit this simulation; at a later date, spring latches may be added by JSC to simulate the latch activation forces.

2.2.2 Locking Pin Assembly

2.2.2.1 Introduction

Since the spring rate resistance varies as the rotation changes, it was desired to make the mockup lockable at various rotation degrees. This allows simulation of rotational failure at different degrees of elevation.

2.2.2.2 Explanation of Operation

The locking pin housing encompasses the cable guide wheels which are located on the Deployment Adapter trunnions inside the CSS shoulders (Figure 4). Holes located on the wheel align with the hole on the pin housing when the Trainer is at 15 degree increments from 0 degree to 45 degrees. There is an additional hole that when used will locate the vehicle at 19 degrees elevation, which is the maximum angle at which the entire assembled vehicle will stay underwater in the WETF. The stainless steel locking pin is tethered to the locking pin housing for easy retention. Specific use limitations outlined in the WETF Operations and Maintenance Manual (Appendix A) must be followed when using the locking pins.

2.2.3 EVA Linkage

2.2.3.1 Introduction

The flight vehicle is rotated from the stowed position to the 45 degree deployment position by its port side rotator motor which is mounted to the rear of the rotating deployment adapter. It is linked by its rotating arm through a clevis pivoting link to the CSS. As the crank arm rotates forward it pulls against the fixed link attached to the CSS, rotating the vehicle to its deployed position. The backup rotator is an identical system on the starboard side of the vehicle. Should a failure occur in the rotating system it may become necessary for an EVA crewmember to disconnect the linkages on both sides of the Centaur for manual restowing of the vehicle in the cargo bay.

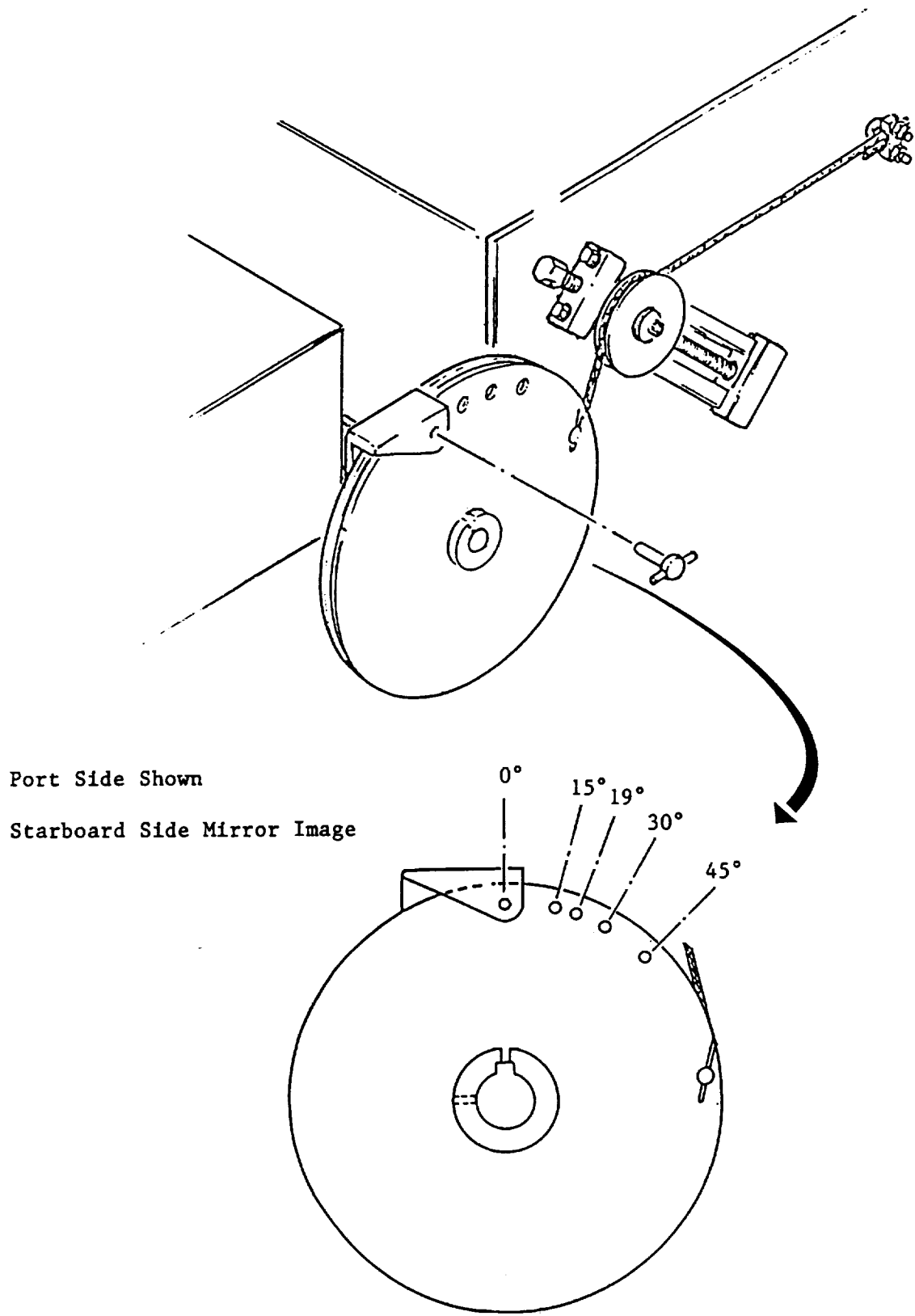

Figure 4: Locking Pin Assembly

2.2.3.2 Explanation of Operation

The Trainer's EVA linkage is identical to the flight EVA linkage (Figure 5). The stainless steel EVA link pin retains the rod end bearing of the link in the clevis. As the locator screw is turned counterclockwise, it is removed from its retaining socket in the bushing. Once this is done, the link pin latch can be swung out of the way allowing the EVA link pin to be removed and freeing the link. For durability and corrosion resistance, stainless steel and bronze were used for the moving parts of the mechanism.

2.3 High-Fidelity Box Add-On

2.3.1 Introduction

During the contract performance a need was identified for an upgrade version of several electrical boxes to a high-fidelity configuration. The boxes upgraded to high-fidelity were the PLIU, PICU (two each), and the connector interfaces on the rotators. This upgrade involved duplicating the flight boxes very closely, including machined bosses and strengthening ribs found on the flight articles. Electrical connectors that surrounded the areas where the crew would remove or connect cabling were provided as well as detailed cabling representation leading to and from the interface areas.

2.3.2 Locations and Description of Work Done

The location of each high-fidelity electrical box can be seen in Figure 6. All electrical boxes stated above were remade except for the rotators. The rotators were originally designed high-fidelity on the exterior because of expected crew interface. Because the rotator required upgrade in the area of the electrical connectors, a new top plate with mount holes for the connectors was provided. All connectors for these boxes are identical to flight connectors. Listed below are the connectors provided for each box.

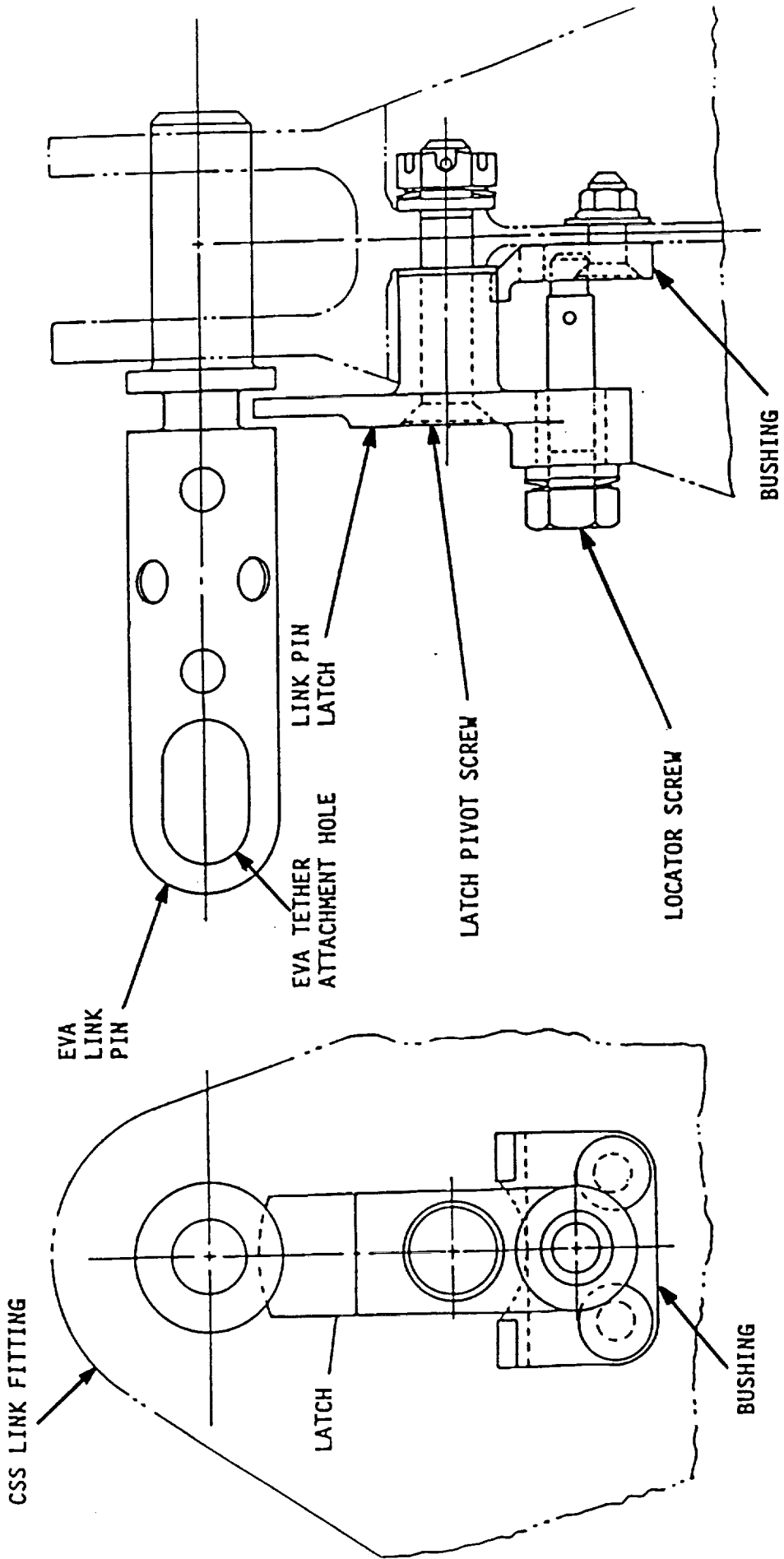

Figure 5: EVA Linkage

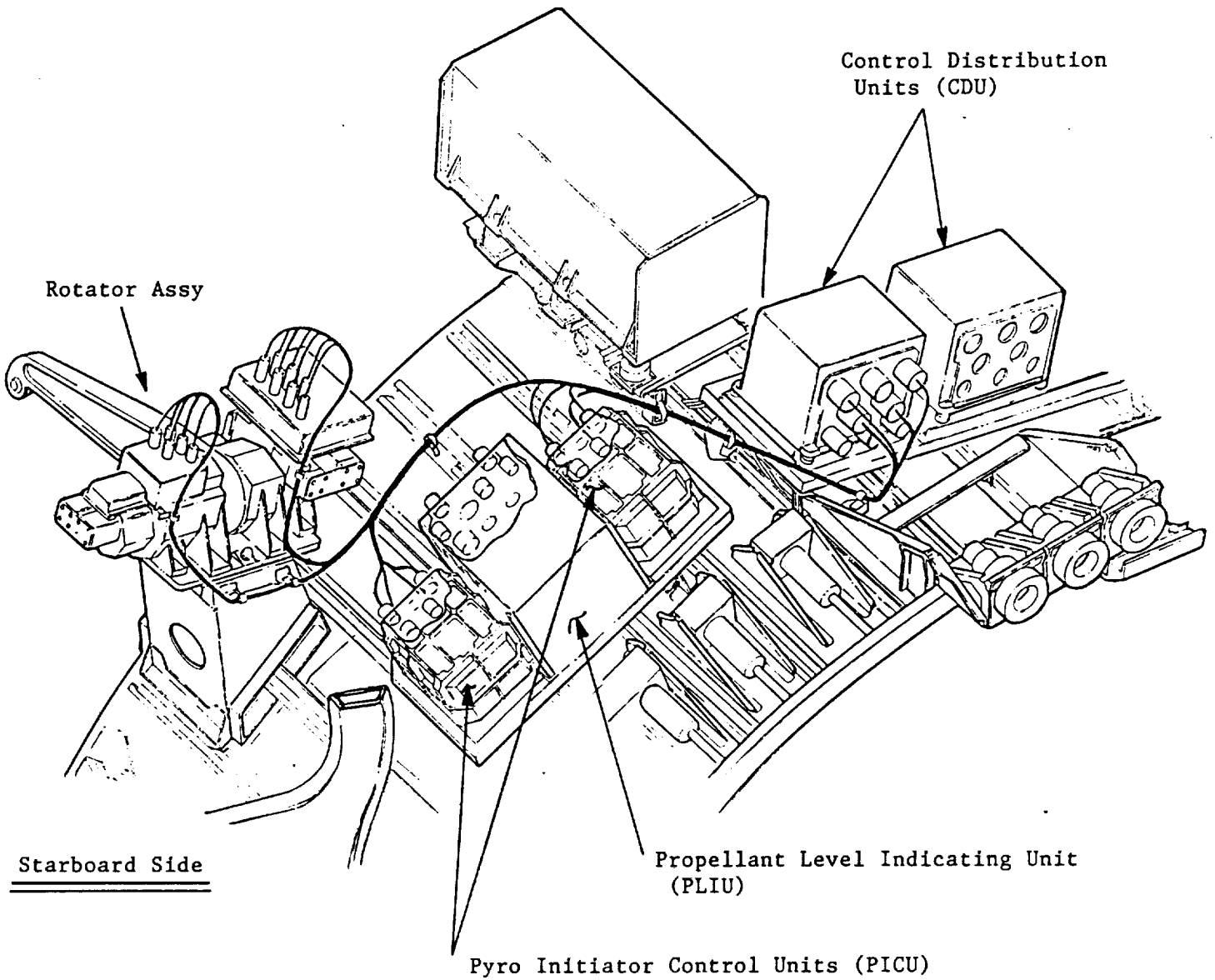

Figure 6: Locations of High-Fidelity Boxes

o Rotators

Receptacle - MS3470L-10-6P & MS3470L-12-10S

Plug - MS3476L-10-6S & MS3476L-12-10P

Backshell - M85049/52-1-10H & M85049/52-1-12N

o CDU

Receptacle - MS27656T25-F6-SA

Plug - MS27467T25-F6-PA

Backshell - MS27506F-24-2

o PICU

Receptacle - MS27656T-13F-98S & MS276S6-T17-26-S

Plug - MS27467T-13F-98P & MS27467T-17F-26-P

Backshell - MS27506F-12-2 & MS27506F-16-2

o PLIU

Flight Connectors were not needed.

Low-fidelity connector was provided. Wire bundles can be added at a later date if needed.

The PLIU exterior is flight-like except in the area that cannot be reached because of the PICU boxes.

The two PICU boxes are high-fidelity with the above stated connectors. The wire bundles were soldered to the plug to prevent the wire from being pulled out. The wire bundles are approximately the same diameter as the flight wiring.

There are two CDU boxes with flight-like exteriors. Only one set of connectors is needed for one CDU box. Both boxes have provisions for attaching connectors. The wire bundles are flight-like in diameter and are soldered to the plug.

All wire bundles are routed in the same locations as on the flight vehicle. Each bundle is approximately 8 feet long.

2.4 Centaur 1-G Mockup

Centaur 1-G is constructed similarly to the WETF Centaur. The CSS is constructed out of 1/4 in. 5052 and 6061 aluminum plate welded together in segments and then bolted together. The rest of the vehicle is cylindrical and conical in shape. 1/4 in. x 4 in. x 4 in. fabricated angle forms bulkheads of each section. These bulkheads are joined by 3 in. wide 1/4 in. thick tee beam runners. Alternating with the tee beam runners are 2 in. x 2 in. x .125 in. thick square tubes for additional strength. These assembled sections are covered with white Fablok fabric, held in place by velcro fasteners.

The Centaur 1-G mockup can be assembled in both the longer G-prime version and the shorter G-version. The mockup is sectioned such that some pieces are removed and some are exchanged from G-prime to G (Figure 1, above). Assembly is detailed in the Centaur 1-G Operations and Maintenance Manual (Appendix C) which was delivered to Building 9A personnel at the time of the mockup delivery.

The Centaur 1-G mockup does not have the spring rate mechanism or the locking pins found in the WETF Centaur. It does have the complete EVA linkage found on the WETF Centaur.

2.5 Documentation

As required by contract, a complete set of reproducible engineering and design drawings as well as a set of blueprints was furnished by Essex to Mr. Harmon Roberts. A table of contents for the drawing set is found in Appendix D.

3.0 CONTRACT PERFORMANCE

3.1 Milestone Schedule

Shown below is the schedule of highlights and milestones during the life of this contract. All contract deliverables were made on schedule.

MILESTONE SCHEDULE

1985

- 29 March - Preliminary Design Review
- 10 April - Engineering Drawing Review
- 22 April - Fabrication begins on WETF Centaur Trainer
- 29 May - Fabrication begins on electrical boxes
- 12 June - Contract Mod for WETF conversion to G
- 4 September - WETF Centaur acceptance review @ Essex
- 10 September - WETF Centaur shipped to JSC
- 17 September - Assembly at JSC of WETF Centaur, briefing of WETF personnel by Essex
- 1 October - Installation of Centaur in the WETF for flotation adjustment
- 1 October - Fabrication begins on I-G Centaur mockup
- 1 October - Design work begins on electrical boxes
Electrical connectors ordered
- 1 November - Machine work begins on electrical boxes
- 5 December - High-fidelity boxes, electrical connectors and cabling shipped to JSC
- 13 December - Essex installs high-fidelity boxes and cabling on WETF Centaur Trainer

1986

- 7 January - I-G acceptance review @ Essex
- 13 January - I-G Centaur shipped to JSC
- 15 January - Assembly at JSC of WETF Centaur, briefing of WETF personnel by Essex
- 5 March - Drawings shipped to JSC
- 10 April - Final report delivered

3.2 Expenditure Chart

The chart below shows projected expenditures over the life of the contract versus actual expenditures incurred. The total contract value is \$317,225 with final contract costs anticipated to be \$311,650.

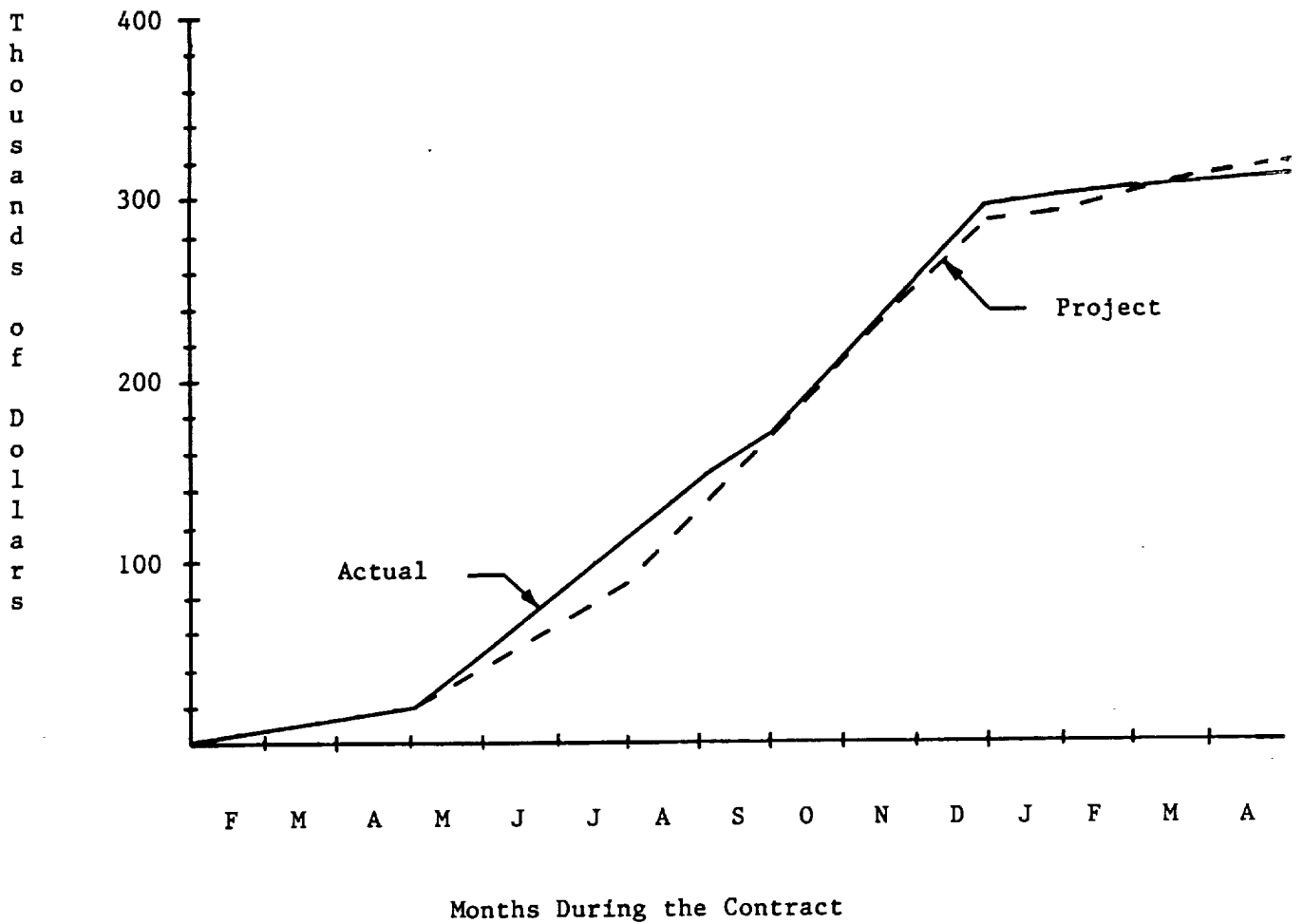

CENTAUR-WETF TRAINER EXPENDITURE CHART

APPENDIX A

Centaur WETF Operations and Maintenance Manual

OPERATIONS AND MAINTENANCE MANUAL

For The
CENTAUR WETF TRAINER

In Support Of:

NAS9-17325

Submitted To:

NASA/JOHNSON SPACE CENTER
Houston, Texas 77058

Provided By:

ESSEX CORPORATION
Space Systems Division
690 Discovery Drive
Huntsville, Alabama 35806

September 13, 1985

1.0 INTRODUCTION

This manual describes the procedures for using and servicing the Essex-built Centaur Trainer. It should be read thoroughly by WETF installation and support personnel before the trainer is put into operation. Any questions regarding the use of the Centaur Trainer can be answered by Harmon Roberts, Johnson Space Center, SP-32 (483-6313) or Alan Ware, Essex Corporation, (205) 837-2046.

2.0 SUPPORT DOLLY

The support dolly is designed to support the Centaur Trainer while out of the water inside the WETF Facility. Rolling the trainer about in the dolly on-site from building to building is not recommended.

The support dolly has four bolt-tethered latches. These latches should be kept closed and bolted down while the trainer is in the dolly. The dolly is supplied with two 3-1/4 in. diameter tubes to enable elevation of the trainer to the 45° deployment position in one-g with the use of the overhead crane. Inspection of the tube ends will reveal that one end is chamfered. This end is the one that installs in the sockets on the main tank with the bolts provided. The other end of the tube bolts through the mounts provided on the front of the dolly. It must be stressed that in one-g, the trainer should not be installed on its support struts without the use of the overhead crane. The crane is to be attached to the red lifting lug installed on the top of the tank section. The casters brakes should be locked while the mockup is being elevated.

3.0 THE CENTAUR TRAINER

The trainer is made up of several large parts bolted together. These are labeled in Figure 1.

The Centaur Support Structure (CSS) is the largest and heaviest part of the mockup, weighing 2,100 lbs. It provides the pivot mount for the rest of the vehicle. It also supports the spring rate simulation mechanism which simulates the spring rate of the flight vehicle as it is elevated up and down. The operation and maintenance procedures required will be discussed in detail later. The CSS will shorten from G-prime to "G".

The Deployment Adapter rests on its pivoting trunnions within the CSS. Mounted on the Deployment Adapter are many of the "black boxes" as well as the simulated rotator mechanisms. Bolted to the Deployment Adapter is the aft adapter skinned section. The seam between these adapters represents the separation plane on the flight vehicle. Everything forward of this seam would be deployed on the actual mission.

Bolted to the aft adapter skinned section is the aft adapter expanded metal section. This is the first section that is removed from the structure when the mockup is reconfigured from G-prime to "G". The differences from G-prime to "G" are shown in Figure 1.

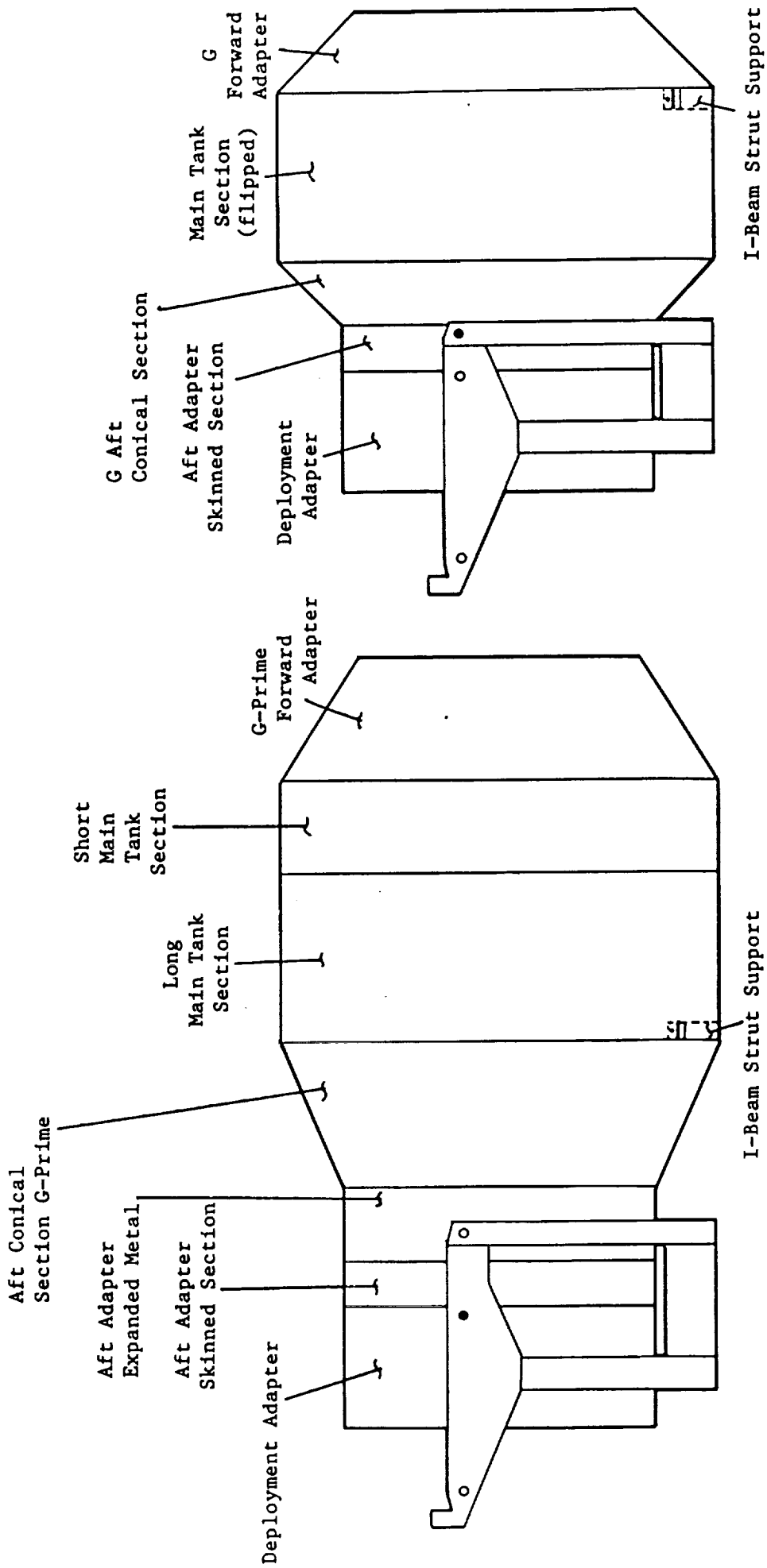

Figure 1:
Centaur Trainer- G-Prime and G Versions

Attaching to the aft adapter expanded metal section is the G-prime aft conical section. This section tapers from 170 in. diameter to 120 in. diameter. It also is removed when reconfiguring the mockup from G-prime to "G". The main tank section bolts on next and is used in both G-prime and "G", but flips over in "G" (see Figure 1). The short main tank section bolts on next and it is removed when reconfiguring from G-prime to "G".

The G-prime forward adapter finishes out the vehicle as it bolts to the short main tank section. The sill trunnion assemblies and various "black boxes" mount on this piece. When reconfigured from G-prime to "G", the G-prime forward adapter is replaced by the "G" forward adapter. The trunnion assemblies are removed from G-prime and installed on "G".

4.0 TYPICAL OPERATION OF CENTAUR IN THE WETF

Due to the length and size of Centaur and the depth of the water in the WETF, certain operating procedures must be followed. The vehicle needs to be unbolted at the separation plane should a full 45° elevation be desired. This allows the deployment adapter to remain neutral so that the spring rate simulation mechanism will work correctly. The deployment adapter cable wheels have a retaining pin housing that enables the deployment adapter to be locked in 15° increments from 0° to 45°. Also provided is a setting that enables locking for the entire assembled vehicle when elevated at its maximum point while remaining under water. This is at 19° elevation. These locking pins are to be used at the same time, and in the case of the entire assembled and elevated vehicle, should be used in conjunction with the overhead crane supporting the front part of the vehicle. The locking pins may be used by themselves only when the deployment adapter is elevated and the trainer is underwater. They are not to be used in one-g under any circumstance. Care should be taken to insure that both locking pins are removed during lifting, moving the trainer about, or after use.

The Deployment Adapter bearings require routine maintenance monthly. Removal of four bolts on the bearing housing allows the housing to be removed (see Figure 2). This exposes the bronze bearing on which the deployment adapter rotates. The bearing and housing should be lubricated with silicon grease. This procedure applies to both sides.

Maintenance should be performed on the spring rate simulation mechanism every month. By removing six socket head cap screws, the top cover may be removed to permit visual inspection (see Figure 2). The bolts on the cable clamps should be checked and tightened if necessary. Silicon grease should be applied to all internal parts and the top cover replaced.

Spring rate mechanism external parts (idler pulley, cable, cable clips and rotator pulley) should be inspected to make sure all bolts and nuts are tight and that the cables and pulleys line up. This procedure applies to both sides.

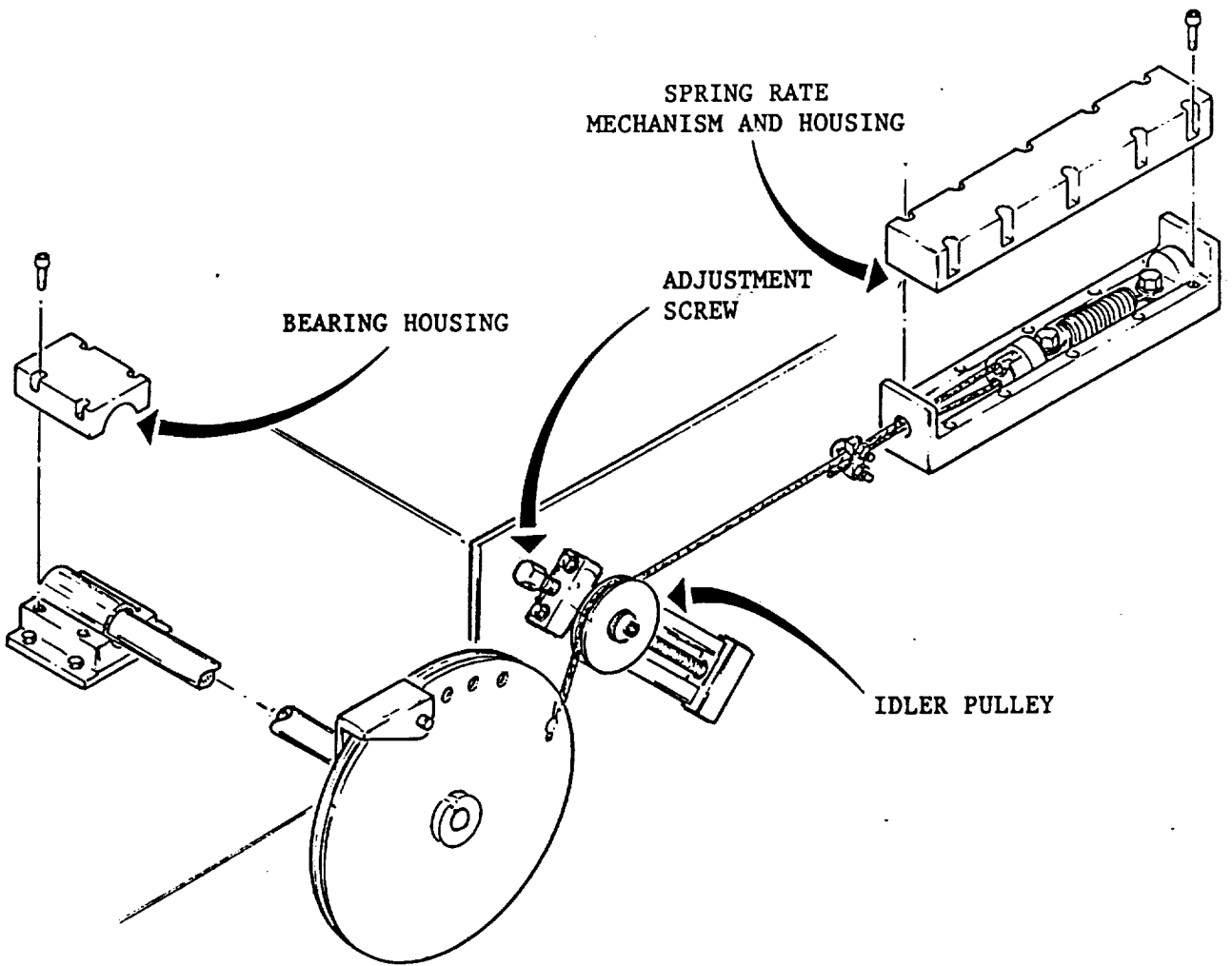

Figure 2: SPRING RATE COMPONENTS

The spring rate simulation mechanism is preset to simulate the rotation torque on the Deployment Adapter. During testing, once the Deployment Adapter has been moved by the Payload Retention Device, the load on the spring rate simulation mechanism may be released safely by using a ratchet and socket on the idler pulley screw. Turning the screw permits the idler pulley to be moved down to release the load on the mechanism. To reset the mechanism, the Deployment Adapter needs to be rotated up in the 45° position and the idler pulley can be ratcheted up until it hits the preset stops. This will adjust the tension on the springs to the simulated rotation rate at the 45° start position.

The rotator arm will require routine maintenance once a month. By loosening two set screws on the rotator hub and four hex bolts on the rotator housing, the rotator arm can be removed (see Figure 3). This will expose the rotator hub which will need to be lubricated with silicon grease. Once the rotator arm is reassembled, the rotator arm set screws will need to be adjusted to simulate the stiffness in the rotator arm. This procedure applies to both sides.

The main tank section is provided with a support foot which enables the trainer to be installed in one piece in the WETF. The tank and forward sections are then separated for elevation purposes. The foot allows these sections to be maintained at the proper bolt height. The forward sections can then be slid forward to allow rotational clearance of the Deployment Adapter and then slid aft to align and bolt the trainer back together for further operation.

5.0 CONFIGURING FROM G-PRIME TO "G"

The Centaur trainer adapts from the longer G-prime version to the shorter "G" version. As mentioned earlier, there are certain hardware pieces which are removed and others which are replaced. The following procedure permits the least time and least work.

The first step is to disassemble the G-prime vehicle down to the aft adapter skinned section. Next, the CSS must be shortened (see Figure 4). Leaving the trunnions in their latches on the dolly, strap and lift the CSS just enough to take the weight off the dolly. Remove the bolts securing the 15 in. spacer section in the shoulders of the CSS and remove the sections. This will allow the forward cradle assembly to rest once again on the forward trunnions, while the forward lifting points provide the support for the rest of the CSS. The short tubular sections between the cradles should now be unbolted and removed, leaving the long sections intact. The center short keep spacer should next be unbolted and removed. Remove the bolts securing the forward trunnion latches, now slide the latch, trunnion, and forward cradle assembly aft to mate with the rest of the CSS. Align the holes and install just the lower two of the six bolts. Unbolt and slide the forward trunnions out of their forward holes and into their aft holes. Insert and tighten the bolts, securing the trunnions in place. Slide the trunnion latches under the trunnions and bolt them into their new holes.

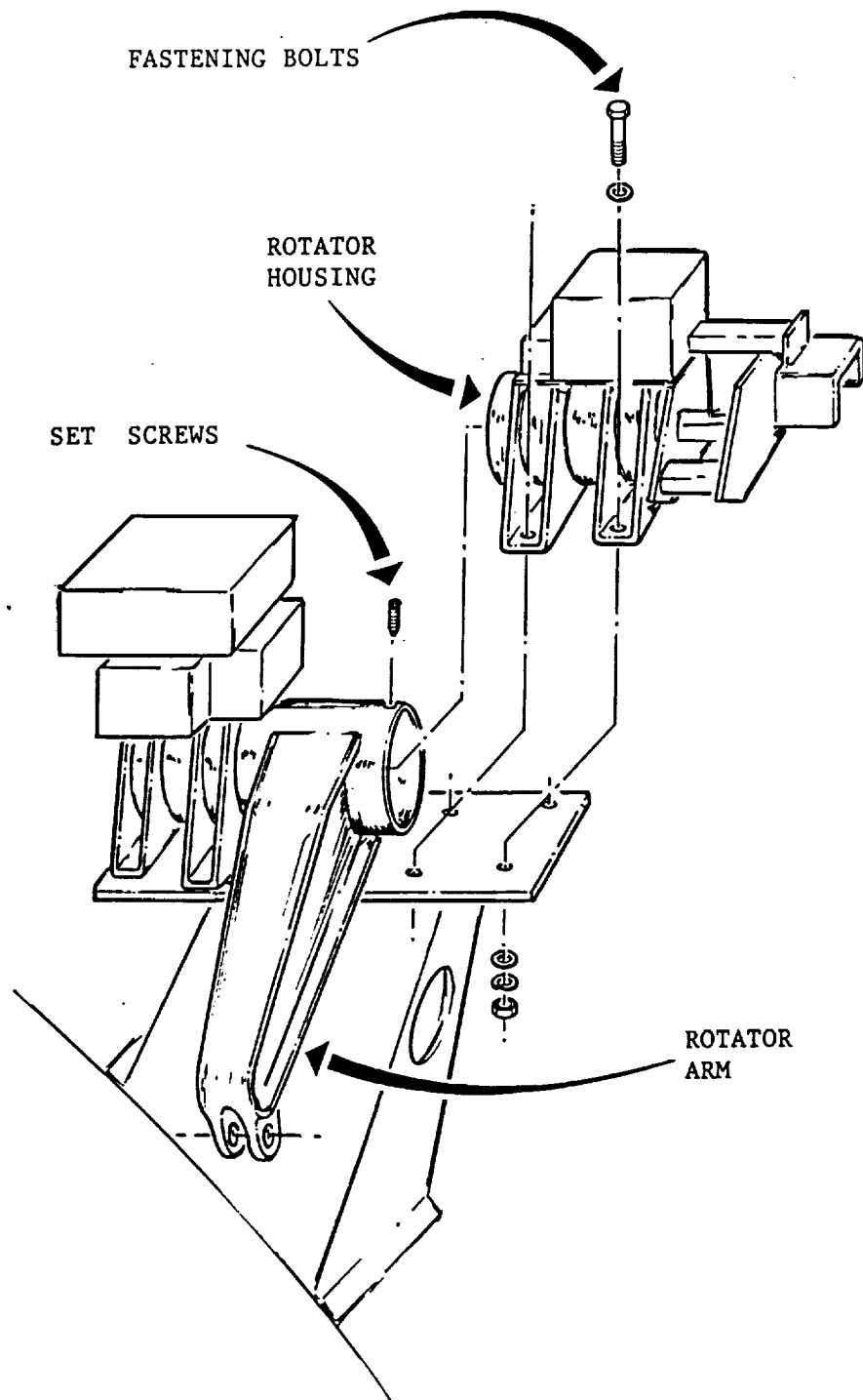
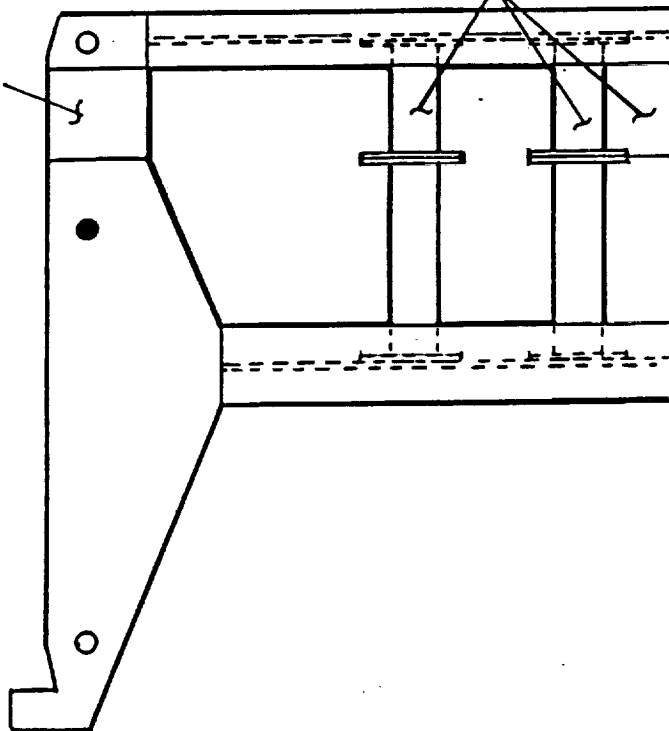

Figure 3: ROTATOR ASSEMBLY

This section is removed from G-Prime to G



G-Prime CSS

Forward frunnion new position

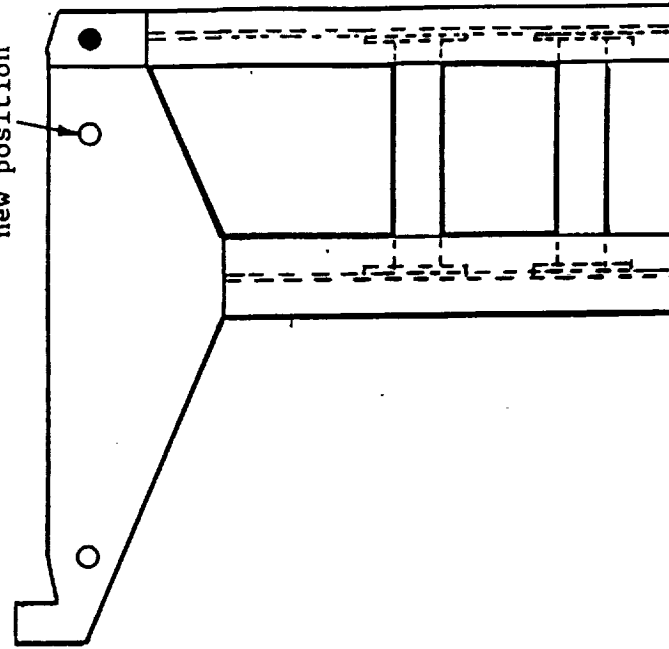

G CSS

These sections are removed from G-Prime to G

Figure 4:
CSS Modifications
from G-Prime to G Versions

Install and tighten the rest of the six bolts on each of the CSS shoulders. Align, insert, and tighten bolts into their respective holes on the long leg tubular supports and long center keel.

Once the CSS has been shortened the forward part of the vehicle is ready for assembly. A new "G" version aft conical section bolts in. The section has a shorter vertical height. Once this section is bolted on, the main tank section is fitted into place and it must go on with the I-beam support structure facing forward. There are two shims under one end of the I-beam. They must be unbolted and moved to the other end at this time. Next the "G" version forward adapter bolts into place. It is shorter in height than the G-prime forward adapter and is skinned with .090 in. sheet aluminum. Before the forward adapter is installed, it will need to have the trunnion assemblies transferred to it. The drag links shorten to install on the mounts already in place on the "G" forward adapter.

6.0 LIFTING SCHEME

The Centaur trainer may be installed in one piece, incorporating a five point lift and using both the Essex-supplied intermediate spreader beam and the NASA supplied main spreader beam. At the time of this writing, the CG has not been established; this necessary information will be provided to WETF personnel upon delivery of the trainer. The lifting scheme showing the basic lifting arrangement is shown in Figure 5. The actual lifting points on the main WETF beam may be relocated as the CG is determined.

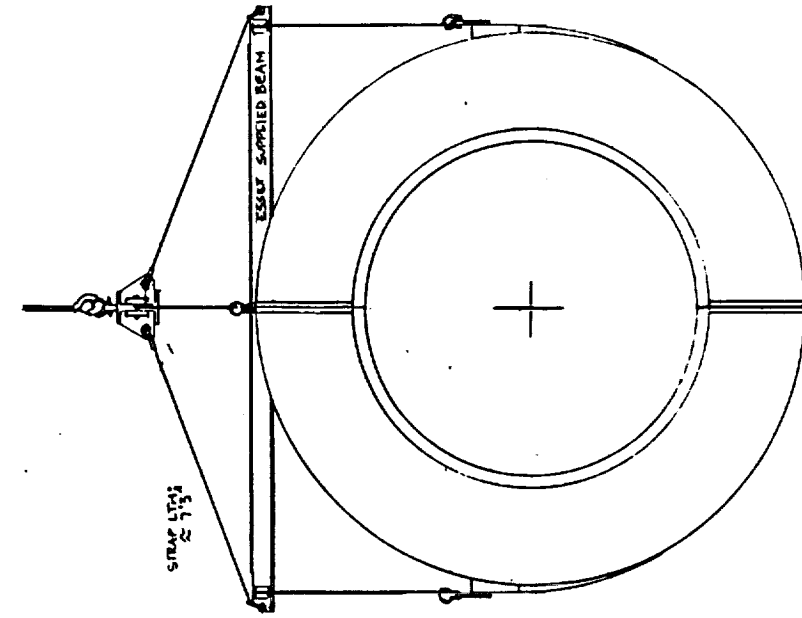

Front View

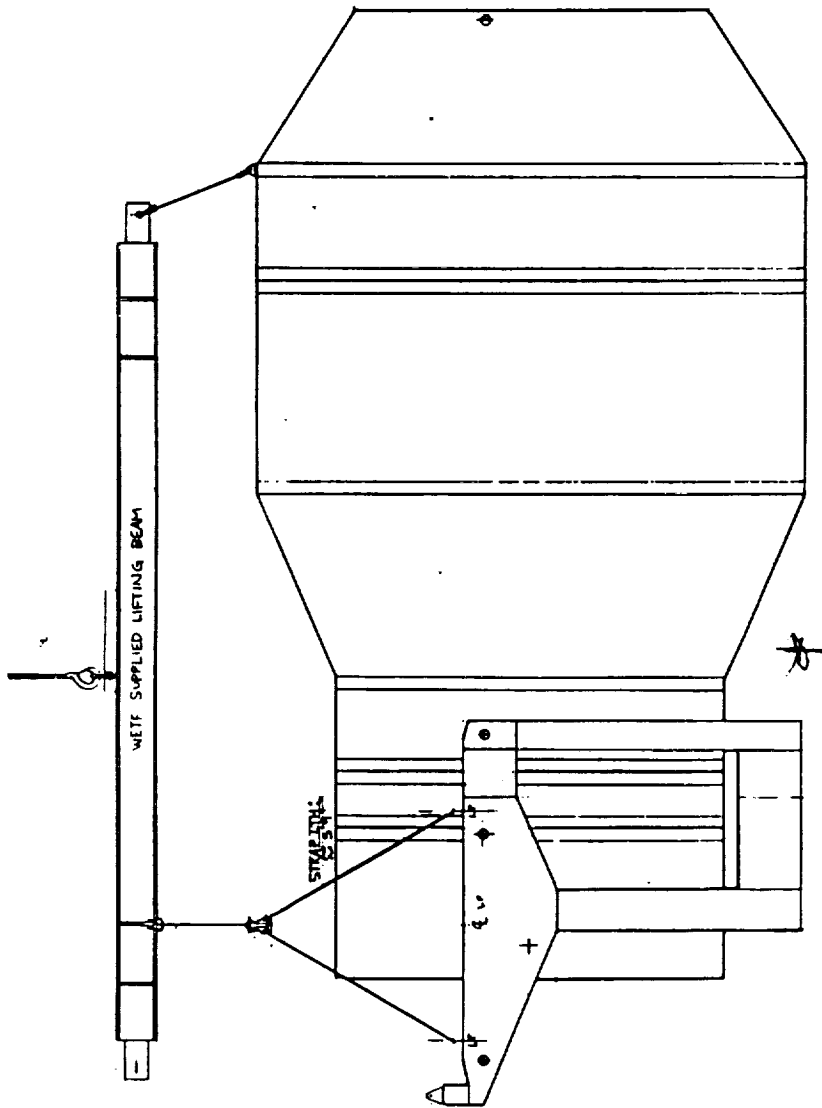

Side View

Figure 5:
Centaur G-Prime Lifting Scheme

APPENDIX B

Patel Engineering Analysis of WETF Centaur

Patel Engineers

**3400 Blue Spring Road
Huntsville, Alabama 35810**

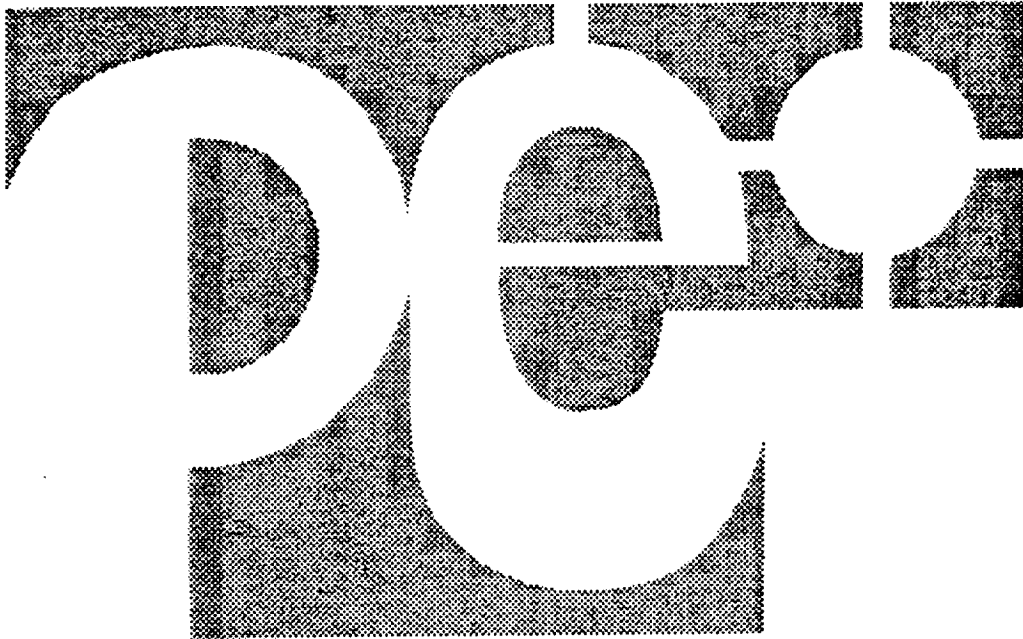

Patel Enterprises, Inc.

TECHNICAL LETTER
PEI-TL-85-99

September 30, 1985

TO: Allen Ware
Essex Corporation
609 Discovery Drive
Huntsville, AL 358907

FROM: Bob Eidson *BLE*

SUBJECT: Documentation for Purchase Order Number 2391

The purpose of this technical letter is to document structural calculations performed by PEI under P.O. Number 2391 on the Centaur mockup built by ESSEX for NASA. The results are summarized in the next several paragraphs with hand calculations presented in Attachment 1. The basic safety requirements for the investigations are a factor of safety of 3 on yield stress or 4 on ultimate stress, whichever is lower. Most of the structure is composed of 6061-T6 aluminum which has a yield stress in tension of 35,000 psi, an ultimate stress in tension of 42,000 psi and an ultimate shear stress of 27,000 psi. All calculations were made with information obtained from Mr. Allen Ware orally or on ESSEX drawings as noted in the list of references in Attachment 2. Item numbers 1 through 5 in the following paragraphs reference the same numbers from the purchase order.

ITEM 1

The center of mass for three sections was determined. They are the CENTAUR long tank configuration, (CENTAUR G-PRIME), CENTAUR short tank configuration (CENTAUR G), and the CENTAUR Support System (CSS). The aft end of the long and short tank configuration are located approximately 36" forward of the CSS aft end. Referencing the aft end of the CSS as X=0, the mass properties of the three sections are:

<u>SECTION</u>	<u>WEIGHT</u>	<u>X-DIMENSION</u>
CENTAUR G-PRIME	5001 lbs.	173.7
CENTAUR G	3870 lbs.	142.6
CSS	2075 lbs.	71.5



ITEM 2

The lifting loads for the CENTAUR G-PRIME are the significant loads of interest and therefore lifting loads were determined only for the CENTAUR G-PRIME/CSS combination. There is a pivot point located approximately 50" forward of the aft end of the CSS. Rotation about this pivot point is allowed to occur at all times. The following summarizes the lifting loads as determined:

<u>LOCATION</u>	<u>FORCE</u>
Forward Lift Point: X=290" (@ 70° with horizontal)	2,431 lbs.
Lifting Load at end of spreader bar: X=56" (total)	4,792 lbs.
Lifting Load at one end of spreader bar	2,396 lbs.
Lifting Load at one lifting lug: X=20" or X=92" (@ 60° with horizontal)	1,383 lbs.

The total vertical load to be lifted is $2,431 \sin 70^\circ + 4,792 = 7,076$ lbs. This load should be lifted at a location of X = 131.3" or just in front of the forward end of the CSS. The CSS is 120.5" long.

The spreader bar is lifted with cables on each end at an angle of approximately 20° with the horizontal. The axial load in the spreader bar is then $2396/\sin 20^\circ = 7005$ lbs. The spreader bar, being 6061-T6 aluminum, has an allowable stress of 10,500 psi using a factor of safety of 4 on the ultimate stress of 42,000 psi. The spreader bar must have an area greater than 0.67 square inches to satisfy safety requirements.

ITEM 3

The load applied to a single lifting lug is 1,383 lbs at an angle of 60° with the horizontal (see Item 2). The allowable shear stress is $27,000/4 = 6,750$ psi for 6061-T6 aluminum. The 0.5" thick lifting ear requires 0.2 square inches of material to satisfy stress requirements. Therefore, 0.5" of material surrounding the 1" diameter hole in the lifting lug will more than satisfy stress requirements.

The 0.5" diameter steel bolts in the lifting lug are well understressed. A very conservative estimate of the shear resistance of one bolt is 2,000 lbs, well above the applied load. The six bolt pattern will be even more conservative.



ITEM 4

The single forward lifting lug must carry 2,431 lbs at an angle of 70° with the horizontal (Item 1). The required shear area is approximately 0.36 square inches (2431/6750). For 1/4" thick material, the required length is 1.5". The 3-1/2" long slot much more than satisfies this requirement. The 1/2" thick tongue for the lug requires at least 0.36" of material surrounding the attachment hole in the tongue. A distance of 0.5" will more than satisfy safety requirements.

The back-to-back channel sections at the top of the CENTAUR G and running the length of the structure is subject to buckling. However, conservative assumptions using both the vertical load to induce moment in the overall cross section and the horizontal load from the lift indicate the critical length is much greater than the length dimensions of the channels. The conclusion is that buckling will not occur.

Conservative estimates of the stress induced in the composite ring at the intersection of the forward adapter and the short tank indicate the ring meets safety requirements. The induced stresses are well below the allowable stress.

ITEM 5

The wheel loads (per-wheel) calculated were approximately:

<u>LOCATION</u>	<u>WEIGHT</u>
Rear Wheel	1,500 lbs.
Center Wheel	1,500 lbs.
Forward Wheel	1,350 lbs.

Service loads for the wheels are 1,500 lbs. indicating the casters presently in use will suffice.



ATTACHMENT 1

PAGES 1 THROUGH 21



Title _____ Job No. _____

By RLE Date 9-9 Ckd by _____ Date _____

Item 1

WEIGHT SCHEDULE (POUNDS)				
SECTION NAME	CENTAUR (LONG STACK)*		CENTAUR (SHORT STACK)**	
	STRUCTURE	FLOTATION (PVC)	STRUCTURE	FLOTATION (PVC)
FORWARD ADAPTER	640	178	640	150
SHORT TANK	360	130	-	
MAIN TANK	600	188	600	188
AFT CONICAL SECT.	700	188	700	112
SHORT AFT ADAPTER	400	137	-	-
SKINNED AFT ADAPTER PLUS DEPLOYMENT ADAPTER	1200	280	1200	280
TOTAL :	3900	1101	3140	730

* LONG STACK - CENTAUR G - PRIME

** SHORT STACK - CENTAUR G



Title CENTAUR G - PRIME Job No. _____

By RLE Date 9-9 Ckd by _____ Date _____

ORIGINAL PAGE IS
OF POOR QUALITY

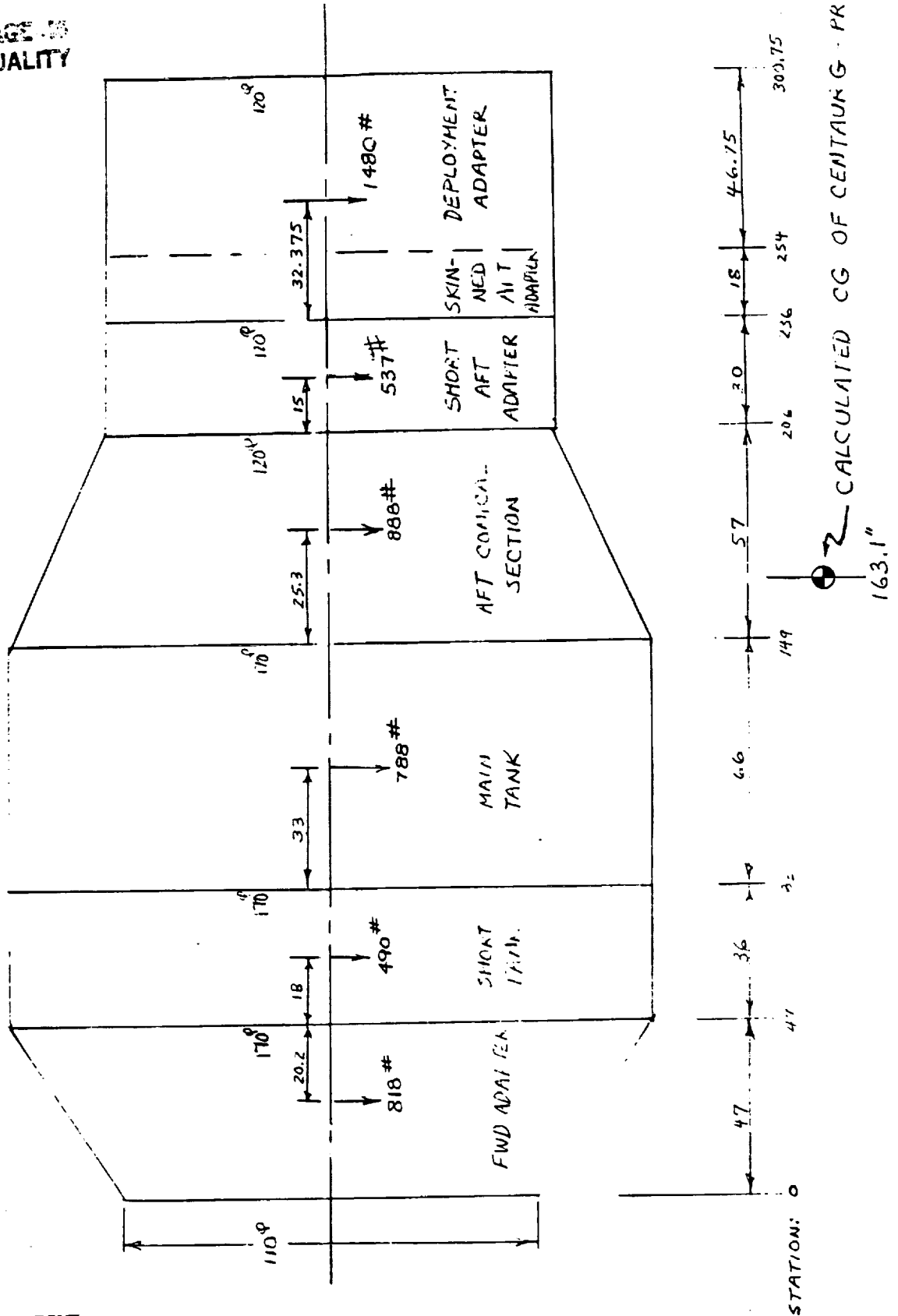



Title CENTAUR G (SHORT STACK) Job No. _____

By P. LE Date 9-9 Ckd by _____ Date _____

ORIGINAL PAGE IS
OF POOR QUALITY

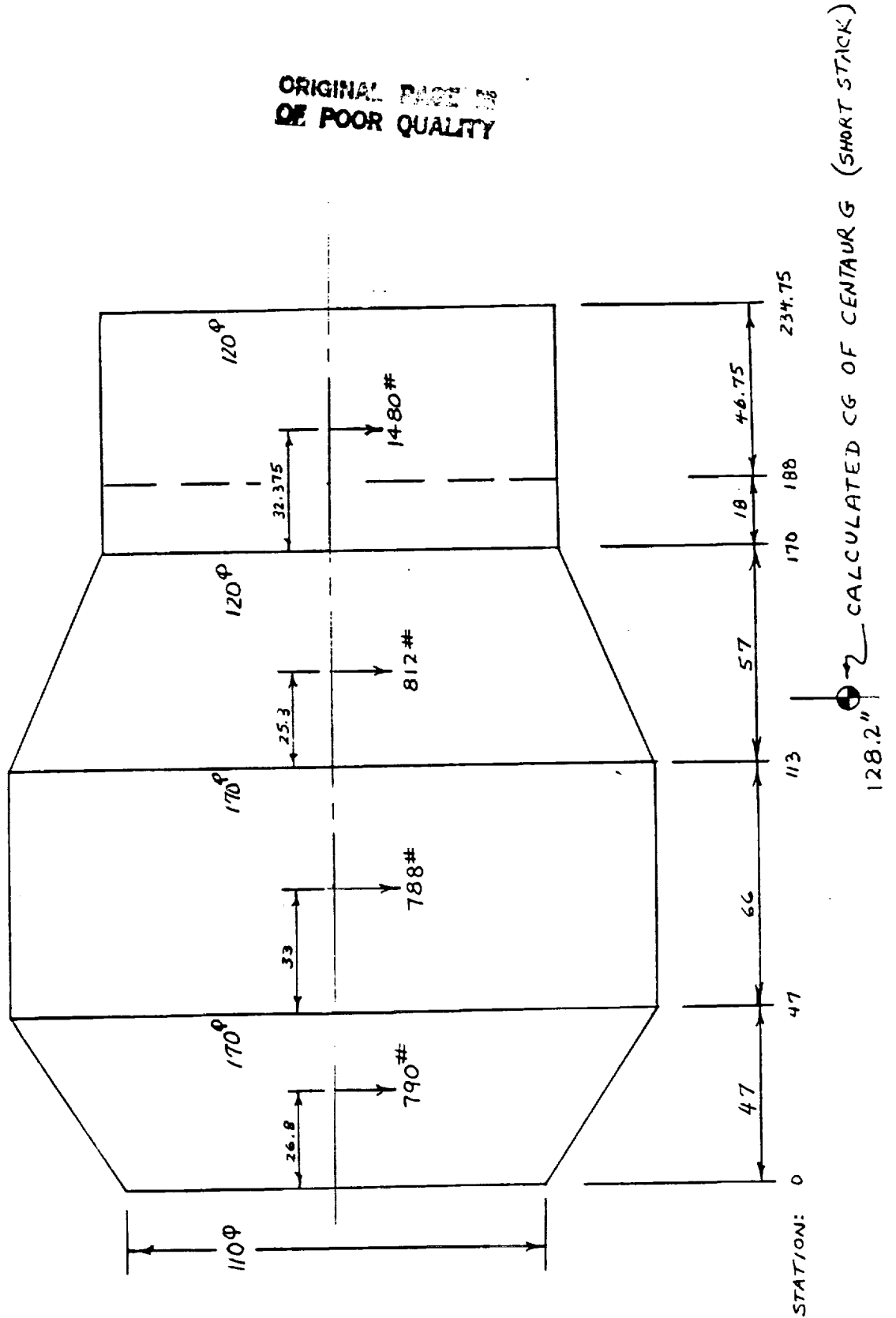



Title CG LOCATION CALCULATIONS Job No. _____

By RLE Date 9-9 Ckd by _____ Date _____

CG OF FWD ADAPTER (Z)

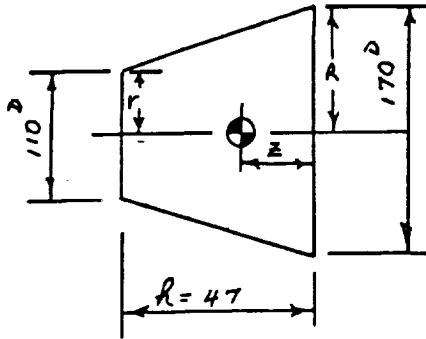

$$z = l \frac{(R^2 + 2Rr + 3r^2)}{4(R^2 + Rr + r^2)}$$

$$z = 47 \frac{[(85)^2 + 2(85)(55) + 3(55)^2]}{4[(85)^2 + (85)(55) + (55)^2]} = \underline{\underline{20.2''}}$$

CG OF AFT CONICAL SECTION (Z)

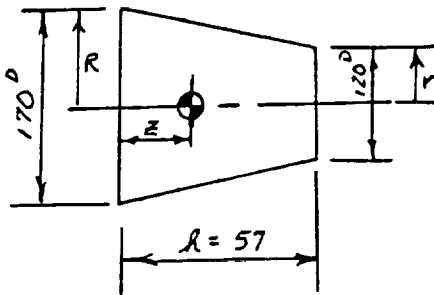

Using above formula,

$$z = 57 \frac{[(85)^2 + 2(85)(60) + 3(60)^2]}{4[(85)^2 + (85)(60) + (60)^2]} = \underline{\underline{25.3''}}$$

CG OF CENTAUR G PRIME (FROM FRONT OF FWD ADAPTER)

$$\bar{Z} = \frac{\sum z_i W_i}{\sum W_i}$$

where \bar{Z} = location of C.G. from origin ($z=0$) of Centaur
 z_i = distance to c.g. of each section from $z=0$
 W_i = Weight of each section

$$\bar{Z} = \frac{(268)818 + (65)490 + (116)788 + (174.3)888 + (221)537 + (268.38)1480}{3900 + 1101}$$

$$\bar{Z} = \frac{815,838}{5001} = 163.1''$$

Title _____ Job No. _____

By RLE Date 9-9 Ckd by _____ Date _____

CG OF CENTAUR G (SHORT STACK)

$$\bar{Z} = \frac{\sum z_i W_i}{\sum W_i}$$

$$\bar{Z} = \frac{(26.8) 790 + (80) (788) + (138.3) (812) + (202.375) 1480}{3140 + 730}$$

$$\bar{Z} = \frac{496,027}{3870} = 128.17''$$



Title _____ Job No. _____

By RLE Date 9-10 Ckd by _____ Date _____

Make the following designations in order to locate CG of CSS section:

A = Shoulder support - Forward Leg per 400045

B = Shoulder support Spacer per 400045

C = Shoulder support - Aft Leg per 400045

Part C

$$A_{\text{face}} \cong 28.25(96.28) - \frac{1}{2}(55)22.25 - \frac{1}{2}(29.3125)(28.25 - 16.375) \\ = 1934 \text{ in}^2$$

$$A_{\text{stiffeners}} = 22(17.25) = 379.5 \text{ in}^2 \quad (\text{Assume all the same})$$

$$A_{\text{top plate}} = 2(96.28)22(.375) = 1589 \text{ in}^2 \quad (\text{both sides})$$

∴ Total weight for Part C is

$$Wt_C = 2(2)1934(.375)\left(1.1 \frac{\text{lb}}{\text{in}^3}\right) + 2(8)(379.5)(.375)\left(1.1 \frac{\text{lb}}{\text{in}^3}\right) + 1589\left(1.1 \frac{\text{lb}}{\text{in}^3}\right) \\ = \underline{\underline{676.7 \text{ lbs}}} \quad (\text{includes 2 face sheets and 8 stiffeners per side})$$

Part A

Estimate weight at 150 lbs (Not a sensitive value)

Part B

Estimate weight at 150 lbs (Not a sensitive value)

Aft Leg of CSS

$$A_{\text{web}} = 74.16 \left(\frac{83}{180}\right) \pi (22.5) = 2417 \text{ in}^2$$

$$t_{\text{web}} = .375 \text{ in}$$

$$A_{\text{flange}} = 2(74.16) \left(\frac{83}{180}\right) \pi (12) = 2578 \text{ in}^2$$

$$t_{\text{flange}} = .25 \text{ in}$$



Title _____ Job No. _____

By RLE Date 9-10 Ckd by _____ Date _____

$$\therefore \text{Wt. per leg} = [2417(.375) + 2578(.25)] \cdot 1(1.05) = 162.84 \text{ lbs}$$

(added 5% for stiffeners) ↗

2 Legs weigh 325.7 lbs.

Fwd Leg of CSS

$$A_{\text{web}} = 74.16 \left(\frac{\pi}{2}\right) 22.5 = 2621 \text{ in}^2 \quad t_{\text{web}} = .375 \text{ in}$$

$$A_{\text{flange}} = 2(74.16) \frac{\pi}{2} (9) = 2096.8 \text{ in}^2 \quad t_{\text{flange}} = .25 \text{ in}$$

Add 7% additional weight for stiffeners and top straight sections

$$\therefore \text{Wt. per leg} = [2621(.375) + 2096.8(.25)] \cdot 1(1.07) = 161.3 \text{ lbs}$$

2 Legs weigh 322.5 lbs

Tube Support

$$\text{Wt. for one is } .1 \frac{\text{lb}}{\text{in}^3} [2(.375)(10)10 + 2\pi(3)(.25)\{.34.25 + 18.81\}] = 32.5 \text{ lbs}$$

\therefore For four supports Wt. = 130 lbs

Channel Support

$$\text{Wt.} = \frac{2.83}{12} \left(\frac{\text{lb}}{\text{in}}\right) [2(23.68) + 2(29.25 + 15.25)] = \underline{\underline{32.2 \text{ lbs}}}$$

(weight per foot is 2.83 lbs)

This includes both sections

Rear Strut (Item 11 per 400045)

Strut weighs 175 lbs per conversation A. Ware / L. Katz.



Title _____ Job No. _____

By RLE Date 9-10 Ckd by _____ Date _____

Summary of weights

ORIGINAL PAGE IS
OF POOR QUALITY

Item	Weight (Unmodified)	Weight (Modified)
Part A	150 lbs	150 lbs
Part B	150 lbs	150 lbs
Part C	677 lbs	789 lbs
Aft Legs	326 lbs	326 lbs
Fwd Legs	323 lbs	323 lbs
Tube Supports	130 lbs	130 lbs
Channel Supports	32 lbs	32 lbs
Strut	175 lbs	175 lbs
Total	1963 lbs.	2075 lbs

Total weight was known to be 2075 lbs. An additional weight of 112 lbs was added to Part C to account for this weight. Assume same distribution as Part C.

CG Location for Part C

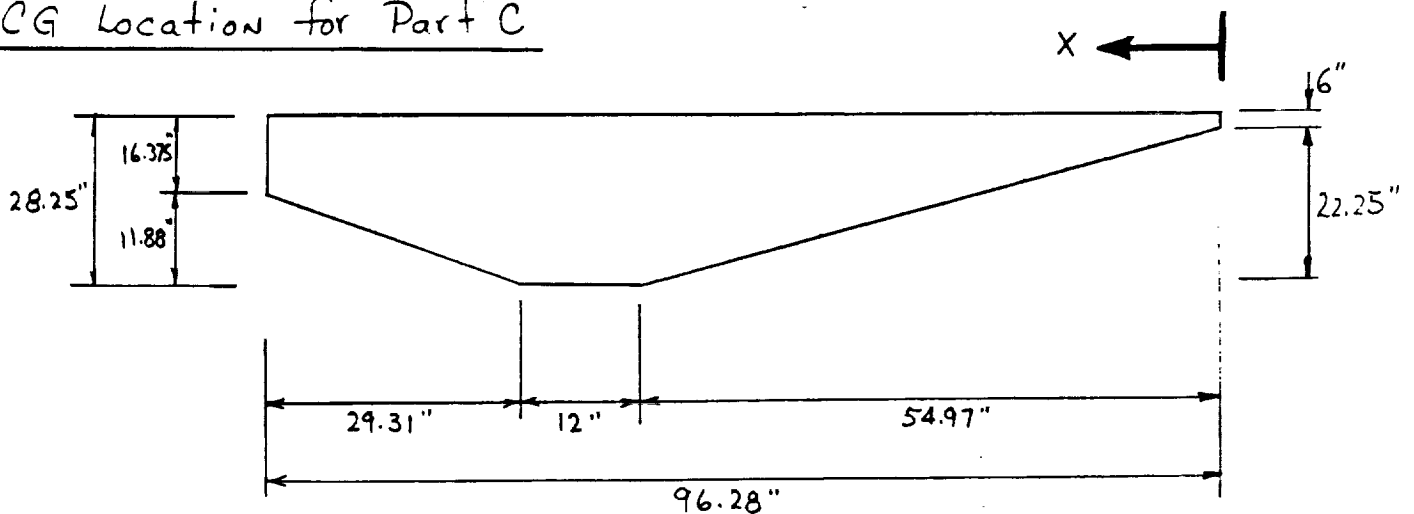



Title _____ Job No. _____

By RLE Date 9-10 Ckd by _____ Date _____

$$A = 28.25(96.28) - \frac{1}{2}(29.3125)(11.88) - \frac{1}{2}(54.97)22.25 = 1934 \text{ in}^2$$

$$\Sigma A \bar{x} = 2720 \left(\frac{96.28}{2} \right) - 612 \left(\frac{54.97}{3} \right) - 174 \left(96.28 - \frac{29.31}{3} \right) = 104,676 \text{ in}^3$$

$$\bar{x} = \frac{104,676}{1934} = 54.12 \text{ in} \quad (\text{note } X=0 \text{ is aft end of Part C, also aft end of CSS})$$

CG Summary for CSS

<u>Item</u>	<u>Wt (lbs)</u>	<u>X-Coordinate (in)</u>
Part A	150	116.00
Part B	150	107.28
Part C	789	54.12
Aft Legs	326	60.97
Fwd Legs	323	116.00
Tube Supports	130	88.49
Channel Supports	32	88.49
Strut	175	3.00

Locate CG of CSS with aft end as a reference

$$\Sigma Wts = 2075 \text{ lbs}$$

$$\begin{aligned} (\Sigma Wts) \cdot \bar{x} &= 150(116) + 150(107.28) + 789(54.12) + 326(60.97) \\ &\quad + 323(116) + 130(88.49) + 32(88.49) + 175(3) \\ &= 148,381.5 \text{ lb in} \end{aligned}$$

$$\bar{x} = \frac{148,381.5}{2075} = \underline{\underline{71.5 \text{ in.}}}$$



Title _____ Job No. _____

By RLE Date 9-10 Ckd by _____ Date _____

Item 2

For lifting calculations consider only the CENTAUR G-PRIME Configuration. The CENTAUR G-PRIME/CSS is pivoted at a location $x=50''$ (with aft end of CSS as a reference). First determine loads transmitted to the CSS through the pivot and then evaluate overall lifting loads.

The CENTAUR G-PRIME is lifted at the forward end by lifting at 70° with the horizontal at $x=289.75''$ and $y=85''$.

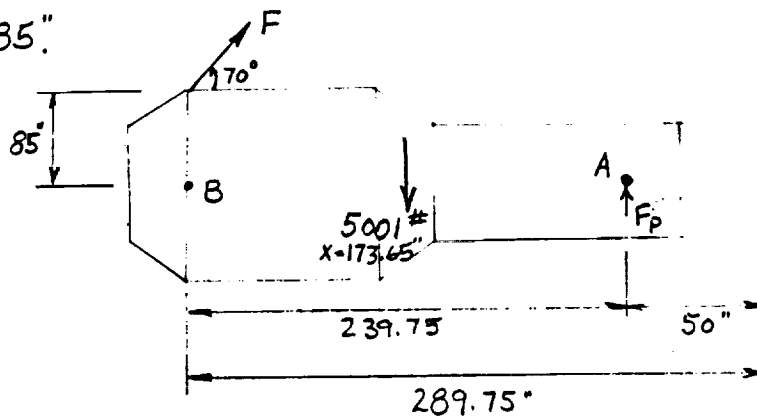

$$\sum M_B = 0 = F_{PV}(239.75) - 5001(289.75 - 173.65) - F_H 85 = 0$$

$$\sum F_Y = 0 \Rightarrow F_{PV} + F_H \frac{\sin 70}{\cos 70} = 5001$$

$$F_{PV} = 5001 - F_H \tan 70$$

$$239.75(5001 - F_H \tan 70) - 85 F_H = 580,616.1$$

$$F_H(-239.75 - 85) = 580,616.1 - 239.75(5001) = 618,374$$

$$F_H = \underline{831.5 \text{ lbs.}}$$

$$F = F_H \left(\frac{1}{\cos 70} \right) = \underline{2431.1 \text{ lbs.}}$$

$$F_V = F \sin 70 = \underline{2284.5 \text{ lbs.}}$$



Title _____ Job No. _____

By RLE Date 9-10 Ckd by _____ Date _____

$$F_{PV} = 5001 - 2284.5 = \underline{\underline{2716.5 \text{ lbs}}}$$

$$F_{PH} = \underline{\underline{831.5 \text{ lbs}}}$$

Now examine CSS with regard to lifting including pivot point load. Lifting cars are located at $X=20''$ and $X=91.5''$.

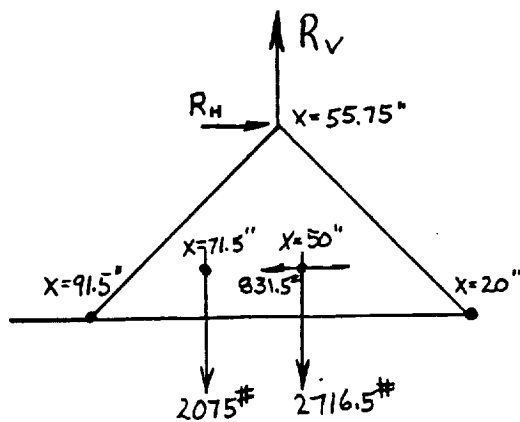

$$R_v = 2075 + 2716.5 = \underline{\underline{4791.5 \text{ lbs.}}}$$

$$R_H = \underline{\underline{831.5 \text{ lbs}}}$$

Determine X location for total lift

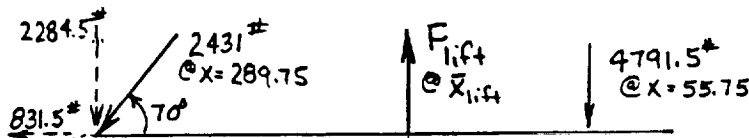

$$F_{lift} = 4791.5 + 2284.5 = \underline{\underline{7076 \text{ lbs.}}}$$

$$X_{lift} = \frac{4791.5(55.75) + 2284.5(289.75)}{7076} = \underline{\underline{131.3 \text{ in.}}}$$

Determine lifting force in each lug on CSS (@60° with the horizontal)

$$F_{lug} \cong R_v \left(\frac{1}{2}\right) \frac{1}{2 \sin 60} = \underline{\underline{1383 \text{ lbs}}}$$



Title _____ Job No. _____

By RLE Date 9-10 Ckd by _____ Date _____

Determine axial load in spreader bar. Spreader bar is lifted with cables at $\approx 20^\circ$. Axial load in spreader bar is

$$F_A = \frac{R_v}{2} \left(\frac{1}{\sin 20^\circ} \right) = \underline{\underline{7005 \text{ lbs}}}$$

For aluminum, the area required for the spreader bar is

$$A = \frac{P}{\sigma_{all}} = \frac{7005}{\frac{1}{4}(42000)} = \underline{\underline{0.67 \text{ in}^2}}$$

This is well below the area of the 4" deep section to be used.



Title _____ Job No. _____

By RLE Date 9-10 Ckd by _____ Date _____Item 3

Stress analyze the CSS lifting ears and their bolts.

The load transmitted to the lifting ears is 1,383 lbs at an angle of 60° (from Item 2). The lifting ear is 0.5" thick.

$$\sigma_{\text{Shear allowable}} = \frac{27,000}{4} = 6,750 \text{ psi for 6061-T6 Al.}$$

$$A_{\text{Shear Req'd}} = \frac{F_{\text{shear}}}{\sigma_{\text{Shear allowable}}} = \frac{1383}{6750} = 0.2 \text{ in}^2$$

For $\frac{1}{2}$ " thick Aluminum ear

$$A_s = \frac{1}{2} (2) L = L$$

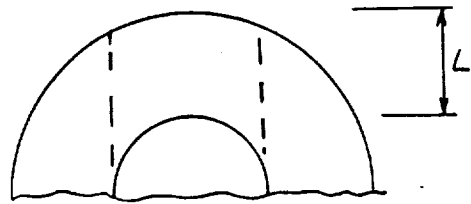

Therefore

$$L_{\text{req'd}} = 0.2 \text{ in}$$

Use $L = 0.5 \text{ in}$ since hole is to be made 1" ϕ

For $\frac{1}{2}$ " Diameter steel bolts

$$A_b = \pi \left(\frac{1}{4}\right)^2 = 0.2 \text{ in}^2$$

Assuming a low strength steel bolt ($\sigma_{SV} = 40,000 \text{ psi}$) the allowable shear load on the bolt (using F.S. of 4)

$$F_{S \text{ allowable}} = \frac{40,000}{4} \cdot (0.2) = \underline{\underline{2,000 \text{ lbs}}}$$



Title _____ Job No. _____

By RLE Date 9-10 Ckd by _____ Date _____

Therefore a single bolt in single shear can carry the applied load of 1,383 lbs. The six bolt pattern is satisfactory.



Title _____ Job No. _____

By RLE Date 9-16 Ckd by _____ Date _____

Item 4

Stress analyze Ring/Rib at Forward Lift Point.

First examine the lifting lug. A phone conversation with A. Ware indicates the slot is $3\frac{1}{2}$ " long and 1" wide.

The slot restrains as shown in the sketch.

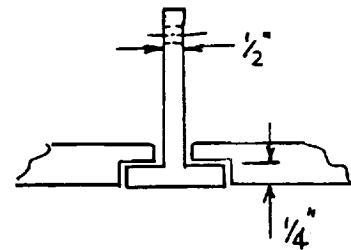

The required shear area $A_{s\text{req'd}}$ is

$$A_{s\text{req'd}} = \frac{2431}{27000/4} = \underline{\underline{0.36 \text{ in}^2}}$$

The required length of such a connection ($\frac{1}{4}$ " thick Al.)

$$L_{\text{req'd}} = \frac{.36}{\frac{1}{4}} = \underline{\underline{1.44 \text{ in}}}$$

\therefore The $3\frac{1}{2}$ " long slot more than satisfies stress req'ts.

The $\frac{1}{2}$ " thick tongue on the lug requires a distance of L_s between hole and outer edge of the tongue.

$$L_s = \frac{0.36}{2(\frac{1}{2})} = \underline{\underline{0.36 \text{ in.}}}$$

A distance of 0.5" will more than satisfy safety requirements.



Title _____ Job No. _____

By RLE Date 9-16 Ckd by _____ Date _____

The channels (back to back) at the top of the CENTAUR G-PRIME and running the length of the structure is subject to buckling. Evaluate this.

$$I = 2 I_{\text{channel}} = 3.32 \text{ in}^4$$

Determine axial compressive load in the channel sections. The lifting load directly dumps 831 lbs. into the section. The bending of the overall cross-section also contributes to this compressive load. Assume:

$$M = 2285^{\#}(100^{\prime\prime}) = 228500 \text{ in lbs}$$

$$I = A d^2 = 2(1.20)(85)^2 = 17340 \text{ in}^4 \quad (A_{\text{channel}} = 1.2 \text{ in}^2)$$

Therefore

$$\sigma_c = \frac{Mc}{I} = \frac{228500(85)}{17340} = 1120 \text{ psi}$$

The total compressive load, F_c , in the back to back channels is

$$F_c = 831 + 1120(1.2) = \underline{\underline{2175 \text{ lbs.}}}$$

Examine buckling by determining the critical length for an axial load of 5000 lbs. If the section is satisfactory for this very conservative load then it is satisfactory for the load of 2175 lbs. (Note that a moment arm of 100 inches was used in the



Title _____ Job No. _____

By RLE Date 9-16 Ckd by _____ Date _____

moment calculation. Do not violate this condition!)

The critical length L_{cr} is

$$L_{cr} = \frac{EI\pi^2}{P_{cr}} = \frac{10 \times 10^6 (3.32)\pi^2}{5000}$$
$$= \underline{\underline{256''}}$$

Since L_{cr} is much greater than any length for which the channels could buckle, the section is satisfactory.

Note that buckling in the other direction is constrained.

Evaluate the stress induced in the ring. The ring is a welded composite section as sketched

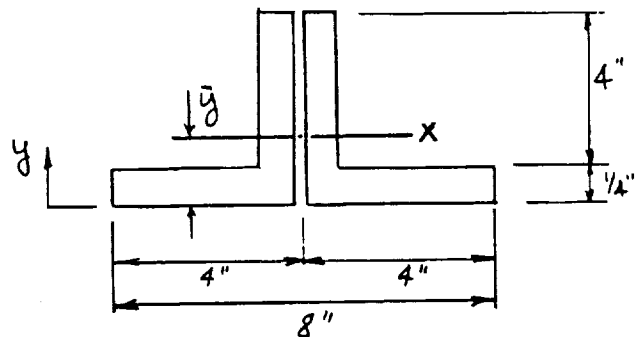



Title _____ Job No. _____

By RLE Date 9-16 Ckd by _____ Date _____

Determine cross-sectional properties of section

$$\bar{y} = \frac{\frac{1}{4}(8)(.125) + 2(4)\frac{1}{4}(2.25)}{8(\frac{1}{4}) + 2(4)\frac{1}{4}} = 1.19 \text{ in}$$

$$I_x = \frac{8(\frac{1}{4})^3}{12} + 8(\frac{1}{4})(1.19 - .125)^2 + \frac{\frac{1}{2}(4)^3}{12} + 4(\frac{1}{2})(1.06)^2$$

$$= 9.86 \text{ in}^4$$

For a uniformly distributed ring load, w in $\frac{\text{lb}}{\text{in}}$, the maximum moment is

$$M_{\max} = \frac{3}{2} \omega R^2$$

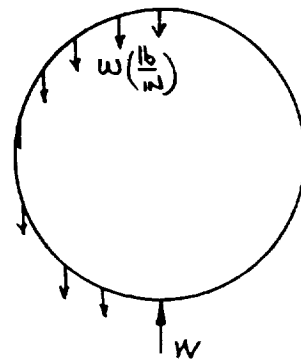

Assume 50% of the applied load of 2285 lbs is dumped into the ring.

$$2\pi r \omega = \frac{2285}{2} \Rightarrow \omega = \frac{2285}{2\pi r(2)} = \frac{2285}{2\pi(85)^2}$$

$$M_{\max} = \frac{3}{2} \omega R^2 = \frac{3}{2} \left(\frac{2285}{2\pi(85)^2} \right) 85^2 = 23,183 \text{ in lbs.}$$

$$\sigma_{\text{applied}} = \frac{MC}{I} = \frac{23183(3.06)}{9.86} = \underline{\underline{7,195 \text{ psi}}}$$

This is much less than the allowable of 10,500 psi for the 6061-T6 Aluminum. Therefore, the ring is satisfactory.



Title _____ Job No. _____

By RLE Date 9-16 Ckd by _____ Date _____

Item 5

Determine the wheel loads on the dolly casters. Based on a sketch of the dolly the estimated weight of the dolly for one side of the structure was 780 lbs. The total weight of the dolly was 1560 lbs. A conversation with A. Ware indicated the dolly weight is approximately 1750 lbs. Assuming the casters weigh 100 lbs, the estimated weight was modified to give the proper overall weight. The additional weight to be added is:

$$W_{\text{add}} = 1750 - 100 - 1560 = 90 \text{ lbs}$$

Distribute this equally to the 6 wheels (15 lbs per wheel)

The dolly loads on the casters are:

Rear wheel - 254 lbs

Center wheel - 350 lbs

Forward wheel - 221 lbs

Assume the loads from the lifting calculations are valid for the in-cradle CENTAUR G-PRIME configuration.

Also, assume the forward lifting load from that analysis goes directly to the front wheels ($2285/2 = 1143 \text{ lbs/front wheel}$).



Title _____ Job No. _____

By RLE Date 9-16 Ckd by _____ Date _____

Examine the loads from the pivot point transmitted to the trunions

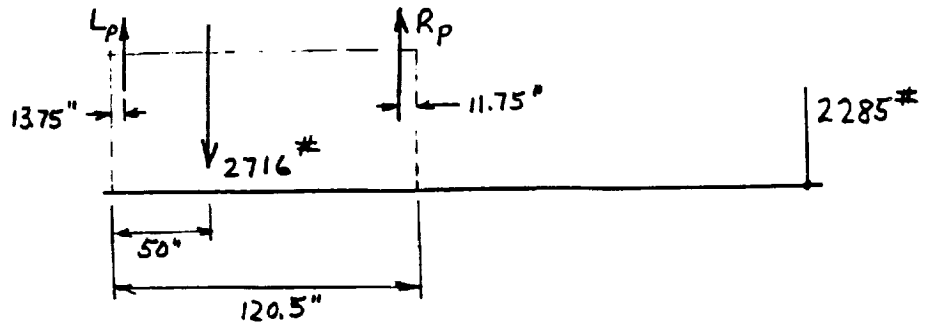

$$L_p = \frac{58.75}{95} (2716) = \underline{\underline{1680 \text{ lbs}}}$$

$$R_p = 2716 - 1680 = \underline{\underline{1036 \text{ lbs}}}$$

$$\text{Check } (L_p + R_p) + 2285 =$$

$$(1680 + 1036) + 2285 = \underline{\underline{5001 \text{ lbs}}}$$

O.K.

Examine the loads from the CSS transmitted to the trunions

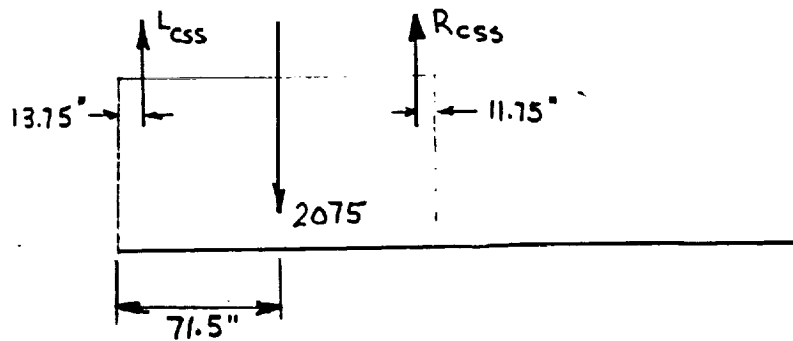

$$L_{css} = \frac{37.25}{95} (2075) = \underline{\underline{814 \text{ lbs}}}$$

$$R_{css} = 2075 - 814 = \underline{\underline{1261 \text{ lbs}}}$$



Title _____ Job No. _____

By RLE Date 9-16 Ckd by _____ Date _____

Distribute pivot point loads and CSS weight directly to rear and middle wheels without accounting for offset of trunion points. A summary of the loads are:

	<u>Dolly Weight</u>	<u>Pivot</u>	<u>CSS</u>	<u>Total</u>
Rear Wheel	254 lbs	840 lbs	407 lbs	1501 lbs
Center Wheel	350 lbs	518 lbs	631 lbs	1499 lbs
Forward Wheel	221 lbs	1143 lbs	0 lbs	1364 lbs

The casters presently in use have a service load rating of 1500 lbs. They are satisfactory for the loads as calculated.

LIST OF REFERENCE DRAWINGS FROM ESSEX

1. Drawing No. 00706 - Lifting Lug CSS
2. Drawing No. 400036 - Fwd Leg - CSS Assembly
3. Drawing No. 400037 - Aft Leg - CSS
4. Drawing No. 400038 - Details - Structural Supports
5. Drawing No. 400041 - Shoulder Support Aft Leg
6. Drawing No. 400045 - CSS Structural Assembly
7. Drawing No. 400062 - Deployment Adapter Structure
8. Un-numbered and Un-titled Drawing of Dolly Assembly



APPENDIX C

Centaur 1-G Operations and Maintenance Manual



OPERATIONS AND MAINTENANCE MANUAL

For The
CENTAUR 1-G MOCKUP

In Support Of:

NAS9-17325

Submitted To:

NATIONAL AERONAUTICS AND SPACE ADMINISTRATION
JOHNSON SPACE CENTER
Houston, Texas 77058

Provided By:

ESSEX CORPORATION
Space Systems Division
690 Discovery Drive
Huntsville, Alabama 35806

January 15, 1986

1.0 INTRODUCTION

This manual describes the procedures for using and servicing the Essex-built Centaur Mockup. It should be read thoroughly by installation and support personnel before the trainer is put into operation. Any questions regarding the use of the Centaur Mockup can be answered by Harmon Roberts, Johnson Space Center, SP-32 (483-6313) or Alan Ware, Essex Corporation, (205) 837-2046.

2.0 SUPPORT DOLLY

The support dolly is designed to support the Centaur mockup while out of the cargo bay mockup inside building 9A. Rolling the trainer about in the dolly on-site from building to building is not recommended.

The support dolly has four bolt-tethered latches. These latches should be kept closed and bolted down while the trainer is in the dolly.

3.0 THE CENTAUR MOCKUP

The mockup is made up of several large parts bolted together. These are labeled in Figure 1.

The Centaur Support Structure (CSS) is the supporting cradle part of the mockup. It provides the pivot mount for the rest of the vehicle. The CSS will shorten from G-prime to "G".

The Deployment Adapter rests on its pivoting trunnions within the CSS. Mounted on the Deployment Adapter are many of the "black boxes" as well as the simulated rotator mechanisms. Bolted to the Deployment Adapter is the aft adapter skinned section. The seam between these adapters represents the separation plane on the flight vehicle. Everything forward of this seam would be deployed on the actual mission.

Bolted to the aft adapter skinned section is the aft adapter fabric covered section. This is the first section that is removed from the structure when the mockup is reconfigured from G-prime to "G". The differences from G-prime to "G" are shown in Figure 1.

Attaching to the aft adapter fabric covered section is the G-prime aft conical section. This section tapers from 170 in. diameter to 120 in. diameter. It also is removed when reconfiguring the mockup from G-prime to "G". The main tank section bolts on next and is used in both G-prime and "G", but flips over in "G" (see Figure 1). The short main tank section bolts on next and it is removed when reconfiguring from G-prime to "G".

The G-prime forward adapter finishes out the vehicle as it bolts to the short main tank section. The sill trunnion assemblies and various "black boxes" mount on this piece. When reconfigured from G-prime to "G", the G-prime forward adapter is replaced by the "G" forward adapter. The trunnion assemblies are removed from G-prime and installed on "G".

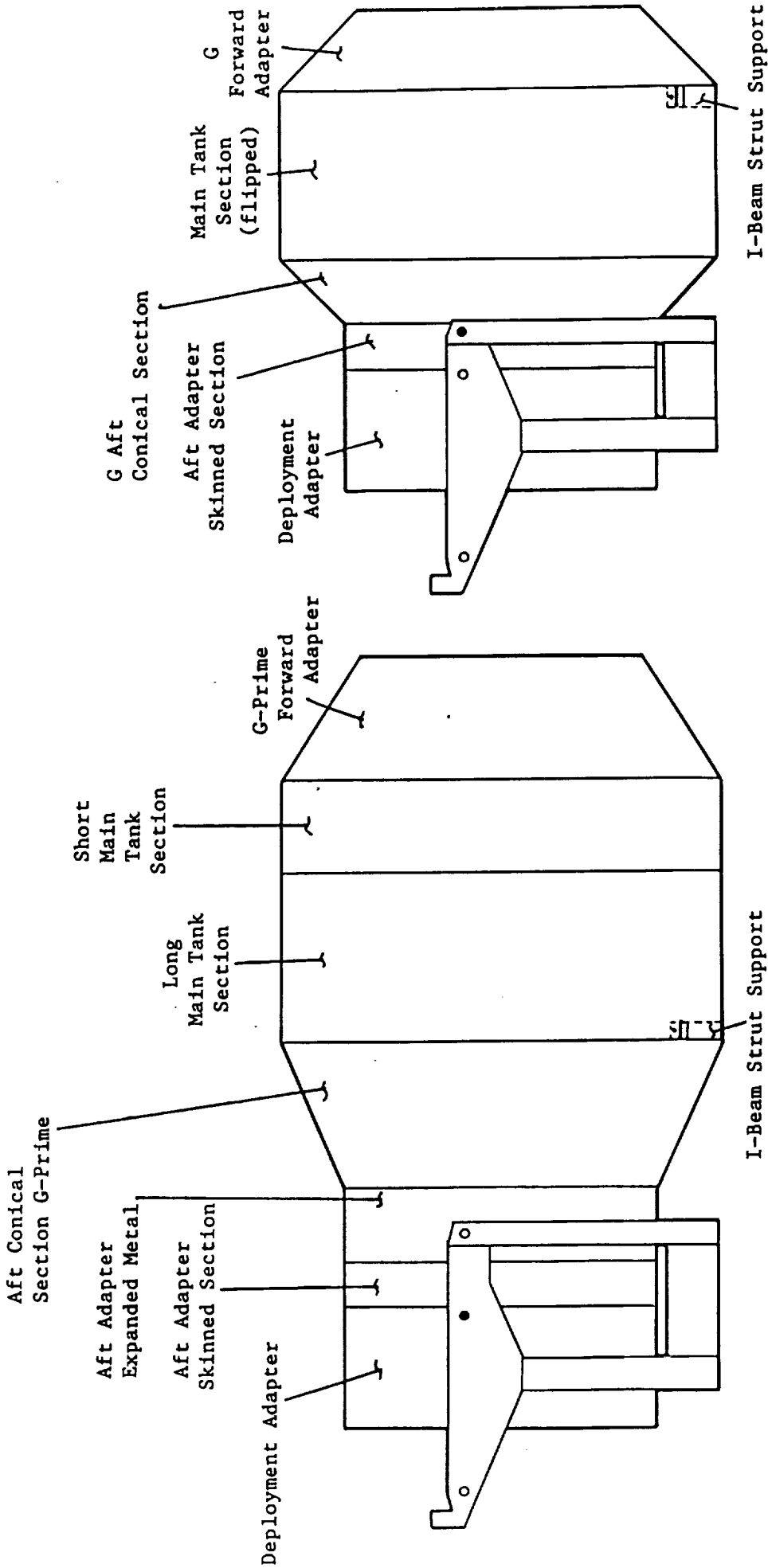

Centaur G-Prime

Centaur G

Figure 1: Centaur Mockup- G-Prime and G Versions

4.0 MAINTENANCE ROUTINES FOR THE 1-G CENTAUR MOCKUP

The Deployment Adapter bearings require routine maintenance every 3 months. With frequent use, the bearings may need to be greased more often. Removing the four bolts on the bearing housing allows the housing to be removed. This exposes the bronze bearing on which the deployment adapter rotates. The bearing and housing should be lubricated with axle-type grease. This procedure applies to both sides.

The rotator arm will require routine maintenance once a month. By loosening four hex bolts on the rotator housing, the rotator arm can be removed (see Figure 2). This will expose the rotator hub which will need to be lubricated with axle-type grease.

5.0 CONFIGURING FROM G-PRIME TO "G"

The Centaur Mockup adapts from the longer G-prime version to the shorter "G" version. As mentioned earlier, there are certain hardware pieces which are removed and others which are replaced. The following procedure permits the least time and least work.

The first step is to disassemble the G-prime vehicle down to the aft adapter fabric section. Next, the CSS must be shortened (see Figure 3). Leaving the trunnions in their latches on the dolly, strap and lift the CSS just enough to take the weight off the dolly. Remove the bolts securing the 15 in. spacer section in the shoulders of the CSS and remove the sections. This will allow the forward cradle assembly to rest once again on the forward trunnions, while the forward lifting points provide the support for the rest of the CSS. The short tubular sections between the cradles should now be unbolted and removed, leaving the long sections intact. The center short keep spacer should next be unbolted and removed. Remove the bolts securing the forward trunnion latches, now slide the latch, trunnion, and forward cradle assembly aft to mate with the rest of the CSS. Align the holes and install just the lower two of the six bolts. Unbolt and slide the forward trunnions out of their forward holes and into their aft holes. Insert and tighten the bolts, securing the trunnions in place. Slide the trunnion latches under the trunnions and bolt them into their new holes. Install and tighten the rest of the six bolts on each of the CSS shoulders. Align, insert, and tighten bolts into their respective holes on the long leg tubular supports and long center keel.

Once the CSS has been shortened the forward part of the vehicle is ready for assembly. A new "G" version aft conical section bolts in. The section has a shorter vertical height. Once this section is bolted on, the main tank section is fitted into place and it must go on with the I-beam support structure facing forward. Next the "G" version forward adapter bolts into place. It is shorter in height than the G-prime forward adapter and is skinned with .090 in. sheet aluminum. Before the forward adapter is installed, it will need to have the trunnion assemblies transferred to it. The drag links shorten to install on the mounts already in place on the "G" forward adapter.

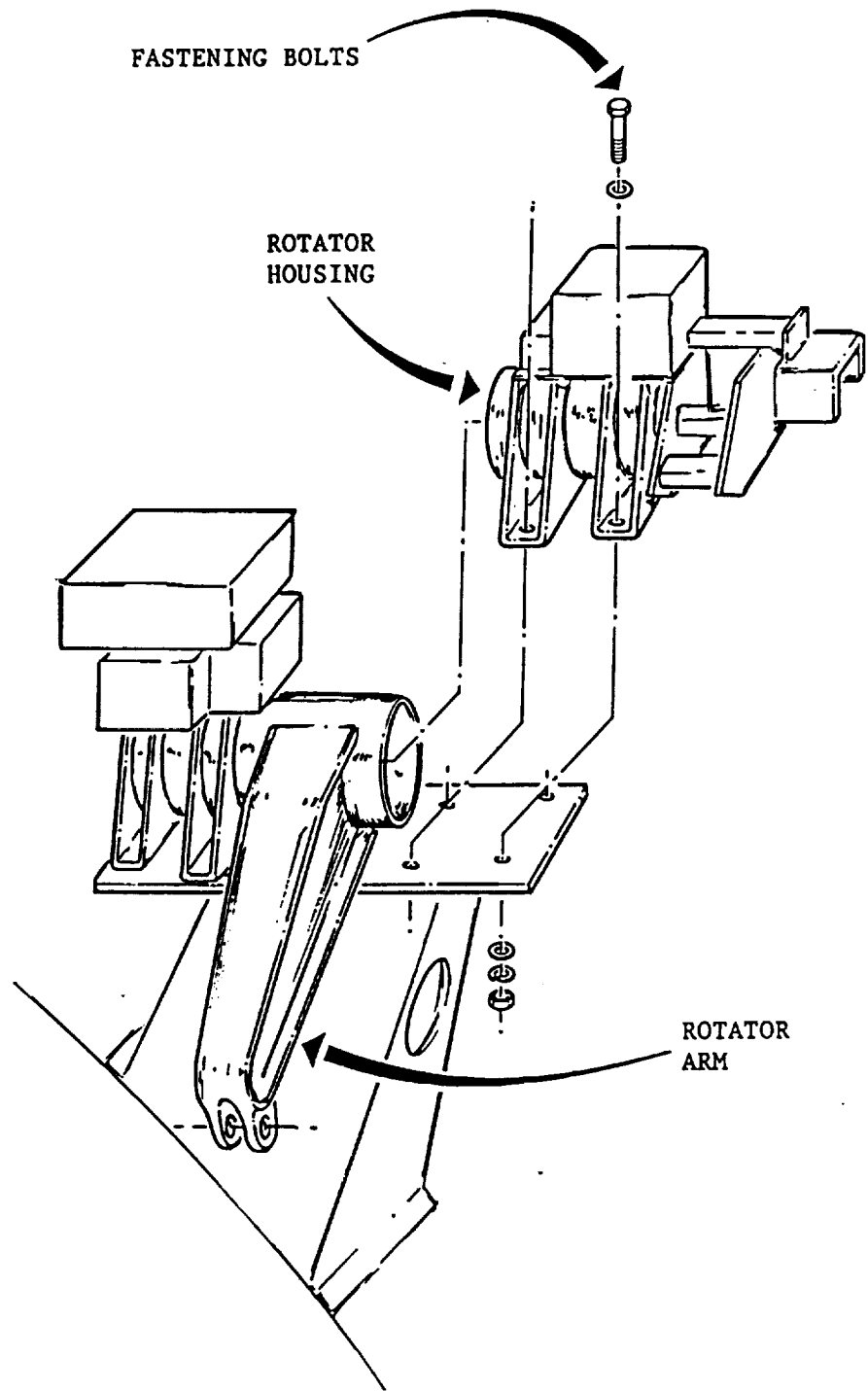
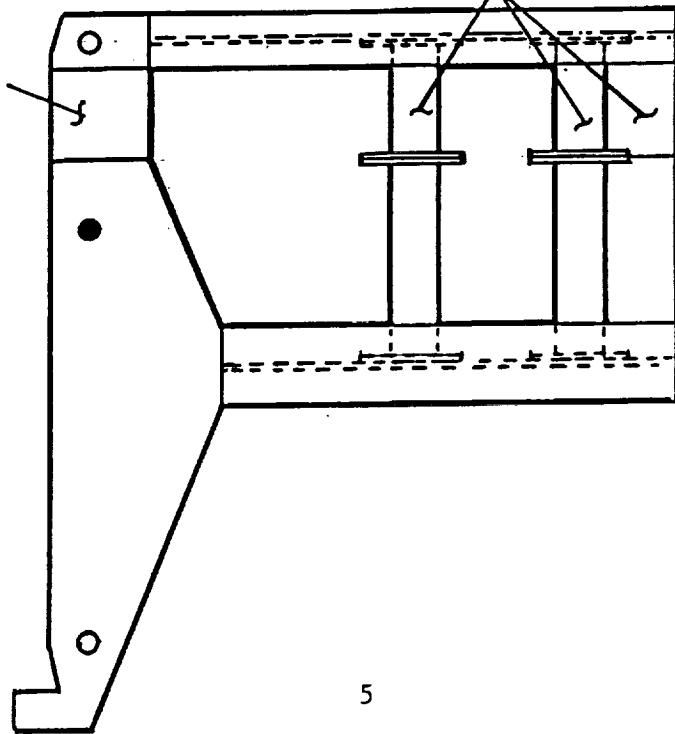

Figure 2: Rotator Assembly

This section is removed from G-Prime to G



G-Prime CSS

Forward trunnion new position

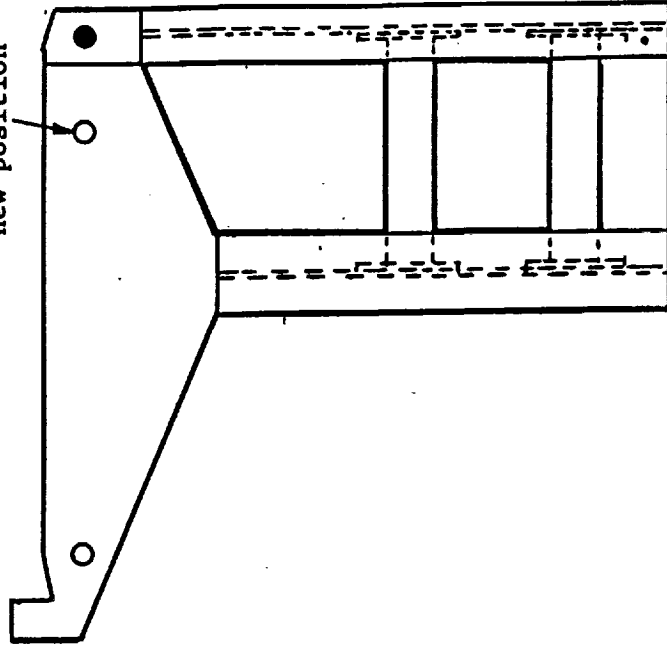

G CSS

Figure 3: CSS Modifications from G-Prime to G Version

6.0 LIFTING SCHEME

The Centaur Mockup should be installed in two pieces. The vehicle unbolts along the separation plane and is equipped with alignment pins to aid in re-assembly. This will make the vehicle available for lifting. The first section will be the CSS and Deployment Adapter. This is to be a four point lift using the four red lugs installed on the shoulders of the CSS. The lifting scheme showing the basic lifting arrangement is shown in Figure 4.

Using the Essex supplied spreader beam slung across the Deployment Adapter (shown in Figure 4), the CSS assembly (weighing 3,000 lbs) can be lifted into place in the cargo bay. The Essex beam should be used to keep vertical loads on the lifting lugs, lifting without the beam should be considered dangerous.

The forward part of the vehicle (weighing 2,500 lbs) can be lifted by the use of the two red lifting lugs, one installed just forward of the separation plane and the other installed just aft of the forward adapter. This is also shown in Figure 4.

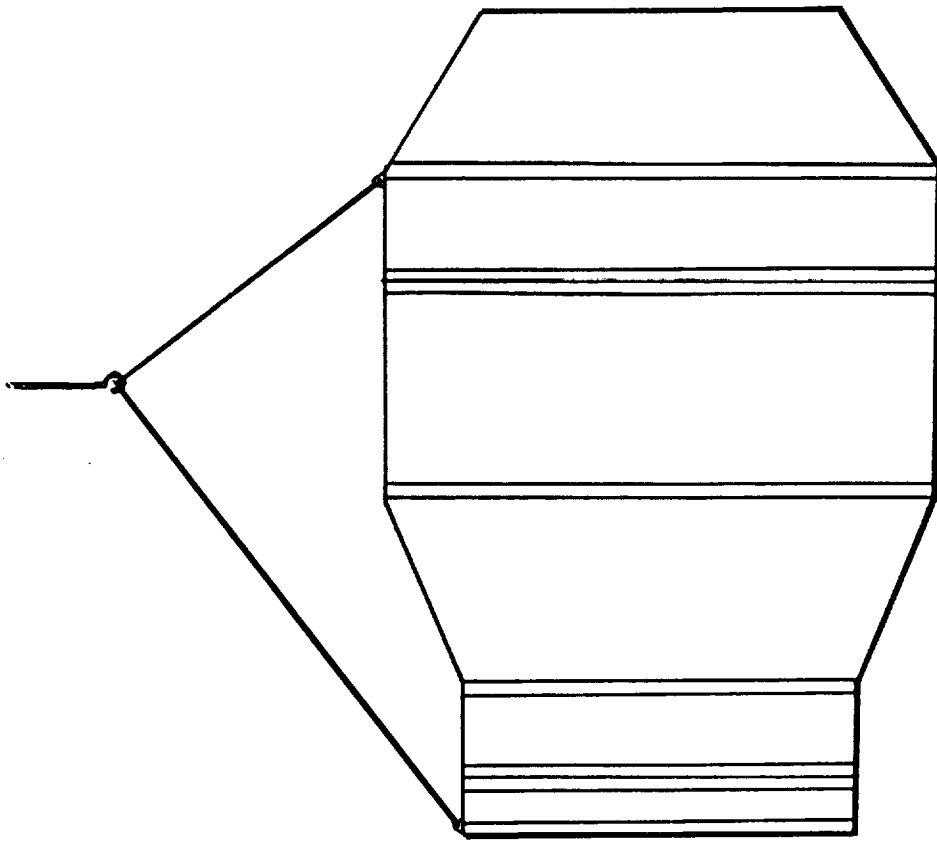

Forward Assembly

Lifting Lugs (2)

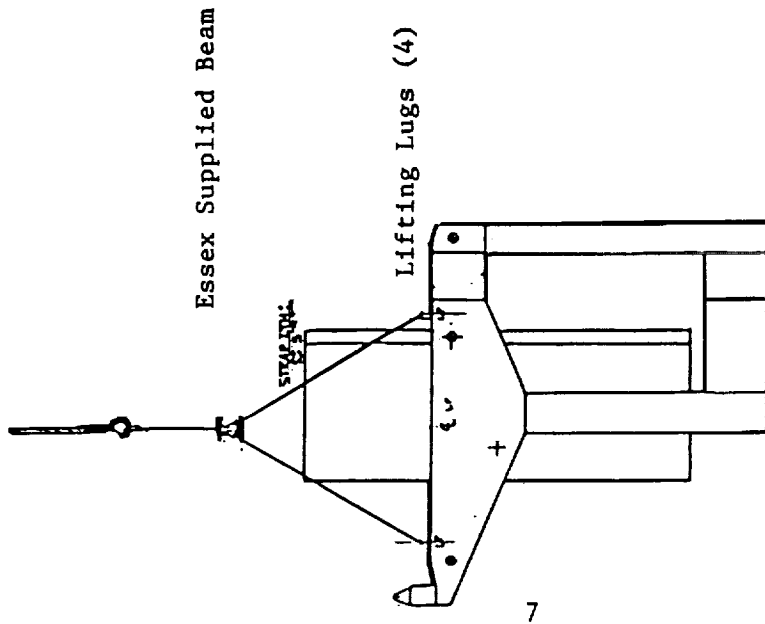

Essex Supplied Beam

Lifting Lugs (4)

Aft Assembly

Figure 4: Centaur G-Prime Lifting Scheme

APPENDIX D

Centaur Drawing List

CENTAUR DRAWING LIST

100001	CSS/ORB Electrical Disconnect
002	PPE
003	Battery
004	DCU
005	UDU
006	EDU
007	8-02U10
008	Spacer
009	Pneumatic Bulkhead
010	CU - Deployment Adapter
011	PCS (RMU)
012	CDU - Deployment Adapter
013	PCIU - Low Fidelity - Deployment Adapter
014	SCU Assembly - Deployment Adapter
015	Wide Band - Deployment Adapter
016	Nozzle Flat Pattern
017	Rod End - Rotator Arm
018	Idler Pulley Shoulder Bolt
019	Support Handrail (Short) CSS Box
020	Support Handrail (Long) CSS Box
021	Support Handrail (Forward) Fluid Disconnect Box
022	Support Handrail (Aft) Fluid Disconnect Box
049	Stops - Rotator Arm
059	Nozzle Bracket - Deployment Adapter
060	Brackets for Nozzle Support - Deployment Adapter
061	Nozzle Bracket - Deployment Adapter
062	Brackets for Disconnect Rods
063	Base, Fuel Line - Deployment Adapter
064	Keel Rod Support - Deployment Adapter
065	Plate, Electrical Cable
200006	Fitting, Deployment
008	CSS Assembly
009	Detail Parts, EVA Pin Assembly
013	Cable Trav - Deployment Adapter
014	Rotator Assembly with Details
025	MVB - Forward Adapter
026	DUFTUS - Forward Adapter
027	SEU - Forward Adapter
028	SCU - Forward Adapter
029	DCU - Forward Adapter
030	PICU - Forward Adapter
041	Aft Adapter Bracket
042	Aft Adapter Spring Bracket
053	Strut End
054	Lifting Lug - CSS
059	EVA Bushing and Screw
060	Guide and Guide Bracket - CSS
061	Bracket Duct, Fuel

Centaur Drawing List Continued

072	Forward Adapter Keel Support
075	Support Dolly Tube Anchor
076	Support Dolly Tube Insert
077	Forward Adapter - Low Gain Antenna Assembly
125	Adjustable Tank Foot
132	Main Tank Foot Back Plate
133	Duct, Fuel Lines
134	Forward Adapter IRU Support
162	CSS Box Assembly
164	Main Body Tank Structure, WETF and 1-G
165	Aft Adapter Basic Structure, WETF and 1-G
172	Deployment Adapter Assembly