

## Report of the Sensor Cooler Technology Panel

Ronald Ross, Panel Chair  
*Jet Propulsion Laboratory, California Institute of Technology*

---

### Members of the Sensor Cooler Technology Panel:

S. Castles, *NASA Goddard Space Flight Center*  
 N. Gautier, *California Institute of Technology*  
 P. Kittel, *NASA Ames Research Center*  
 J. Ludwigsen, *Nichols Research (SDIO)*  
 R. Ross, *Jet Propulsion Laboratory*

---

### INTRODUCTION

Cryogenic cooler performance is a critical system requirement for many space-based spectroscopy and imaging measurements. This is particularly true for measurements of weak signals, such as are typical for astrophysics missions, where it is often necessary to cool the focal-plane sensors and electronics to cryogenic temperatures in order to reduce focal-plane thermal noise sources below the signal levels to be measured. Among the key aspects in which further development in space cryocooler technology is required are the achievement of lower temperatures, larger heat loads, reduced vibration, and longer cooler lifetimes.

The focus of the Sensor Cooler Technology Panel was an analysis of the cryogenic cooler performance required to meet the Astrotech 21 mission set science objectives. A list of the mission set specifications and the pacing cooler technologies is provided in Table I. After a careful review of the mission set, the panel identified four general types of missions where existing cooler technology is expected to be insufficient or marginal. The four categories are:

- Long-life precision-pointing space telescope missions with observations at 2.5 to 10  $\mu\text{m}$ . (HST II & III, NGST, Imag. Int.)
- Long-life missions requiring significant (> 100 mW) cooling capacity in the 2 to 5 K temperature range for periods of up to 15 years. (SMIM, NGOVLBI, LDR, SMMI)
- Long-life missions with subkelvin applications requiring  $\sim 10 \mu\text{W}$  of cooling at 0.1 K with heat sinking to 2 K. (SIRTF, SMIM, LDR, SMMI, AXAF)
- A number of missions which require low-vibration, high-capacity coolers in the 65 K temperature range. (GRSO, NAE)

The panel also reviewed current state-of-the-art capabilities and future potential of the various cryocooler technologies which either have been flown previously or are being considered for space applications. Figure 1 shows a compilation of the primary operating regions for these technologies in terms of the cooling temperature and cooling power ranges they can each be expected to offer. Working from the mission requirements in the context of this analysis of space cryocooler capabilities, the panel developed a four-element technology development strategy to meet the identified challenges of the Astrotech 21 mission set. The four areas recommended for development are:

- Long-life vibration-free refrigerator development for 10 - 20 K and 65 - 80 K temperature ranges for use on missions requiring precision pointing.
- 2 - 5 K mechanical refrigerator development for future long life infrared (IR) and submillimeter (submm) missions with lifetimes exceeding super-fluid He storage tank holding times.
- Flight testing of emerging prototype refrigerators to determine feasibility before they are committed to large, high-visibility astrophysics missions.
- R&D of promising backup technologies to mitigate against failure of one or more of the baseline technologies.

The specific performance requirements in these four areas, the missions impacted, and the associated technology freeze dates are summarized in Table II. The items have not been prioritized. This report describes the panel findings and the recommended development plan to achieve the required capabilities on the necessary time scales. Note that requirements for other areas of space missions were not included in the considerations. The recommendations are restricted to issues of relevance to the specific missions and science objectives of the Astrotech 21 mission set described earlier in this Proceedings.

**Table 1. Astrotech 21 Missions Requiring Advances in Cryocooler Technology**

Mission Instrument	Detector Technology ( $\mu\text{m}$ )	Wavelength Range (K)	Detector Temperature	Cooling Load	Heat Sink (years)	Mission Life	Technology Freeze Date	Pacing Cooler Technology
HST	IR	0.1-2.5	80	0.5 W	LEO	5	1994	No vibration
LTT	CCD	0.12-2.5	100	1 W	Moon	10	1995	Moon surface, life
NGST	$10^4 \times 10^4$	0.1-10	10-30	1 W	EO/Mn	15	2004	No vibration
Imag. Int.	$10^3 \times 10^3$	0.1-10	10-30	1 W	EO/Mn	10	2007	No vibration
SIRTF/IRS	Ge:Ga BIB	36-200	1.3	60 mW	HEO	6	1994	SFHe Vent/Plug
SIRTF/MIPS	Bolometer	100-700	0.1	10 $\mu\text{W}$	2 K	6	1994	Subkelvin ADR
SMIM	Submm	250-700	2-5	15 mW	HEO	2-4	1996	See SIRTF
SMIM	Bolometer	100-900	0.1-0.3	10 $\mu\text{W}$	2 K	2-4	1996	See SIRTF
LDR	Submm	30-3000	2-5	100-300 mW	EO/Mn	10-15	2006	5 K, heat load, life
LDR	Bolometer	30-3000	0.3	100 $\mu\text{W}$	2 K	10-15	2006	Subkelvin
SMMI	SIS	100-800	2-5	20 mW	EO/Mn	10	2006	5 K, long life
SMMI	Bolometer	150-300	0.1	10 mW	2 K	10	2006	Subkelvin
NGOVLBI	Submm	10-220 GHz	5-20	100 mW	EO	10	2000	5 K, long life
AXAF	X-ray	0.09-10 keV	0.1	10 $\mu\text{W}$	2 K	15	1995	Subkelvin ADR
NAE	Ge	Gamma-ray	80	1 W	LEO	2-4	1994	No vibration
GRSO	Ge	Gamma-ray	80	200 W	TBD	15	2004	No vibration, life

**LONG-LIFE VIBRATION-FREE REFRIGERATORS**

**A. Technology Assessment**

Long-life precision pointing space telescope type missions with measurements in the near to mid IR range require vibration-free coolers with ~ 1 W of cooling capacity in the 65 to 80 K temperature range for use with 2.5  $\mu\text{m}$  detectors, and with ~ 20 mW of capacity in the 10 to 20 K range for use with 10  $\mu\text{m}$  detectors. The critical issues are the requirements for no vibration and long life. The requirement for no vibration is expected to exclude present Stirling cooler technologies being developed for Earth Observing System (Eos) missions. Similarly, typical lifetimes of 10 - 15 years also render the use of stored cryogens inappropriate (not cost effective). Thus new approaches will be needed to meet the mission requirements.

**B. Development Plan**

The panel recommends that NASA develop and qualify one or two vibration-free coolers in the two key temperature ranges (10 to 20 K, and 65 to 80 K), for use on space-telescope type missions. Candidate

technologies include sorption refrigerators (Fig. 2), and high-speed turbo-Brayton systems. Both of these technologies have demonstrated technical feasibility in recent lab breadboard tests, but must be carried to the point of engineering model construction and life testing before they can be proposed for flight applications. These technologies are ready for engineering model development, but remain unfunded at this time. An appropriate development schedule is shown in Table III.

**MECHANICAL REFRIGERATORS FOR 2 TO 5 K**

**A. Technical Assessment**

Long-life IR and submm missions require significant (> 100 mW) cooling capacity in the 2 to 5 K temperature range for periods of up to 15 years. This type of mission considerably exceeds (by more than a factor of 10) the cooling capacity being developed for SIRTF (see Figs. 3 to 5), and is probably unrealistic (not cost effective) for a stored cryogen system.

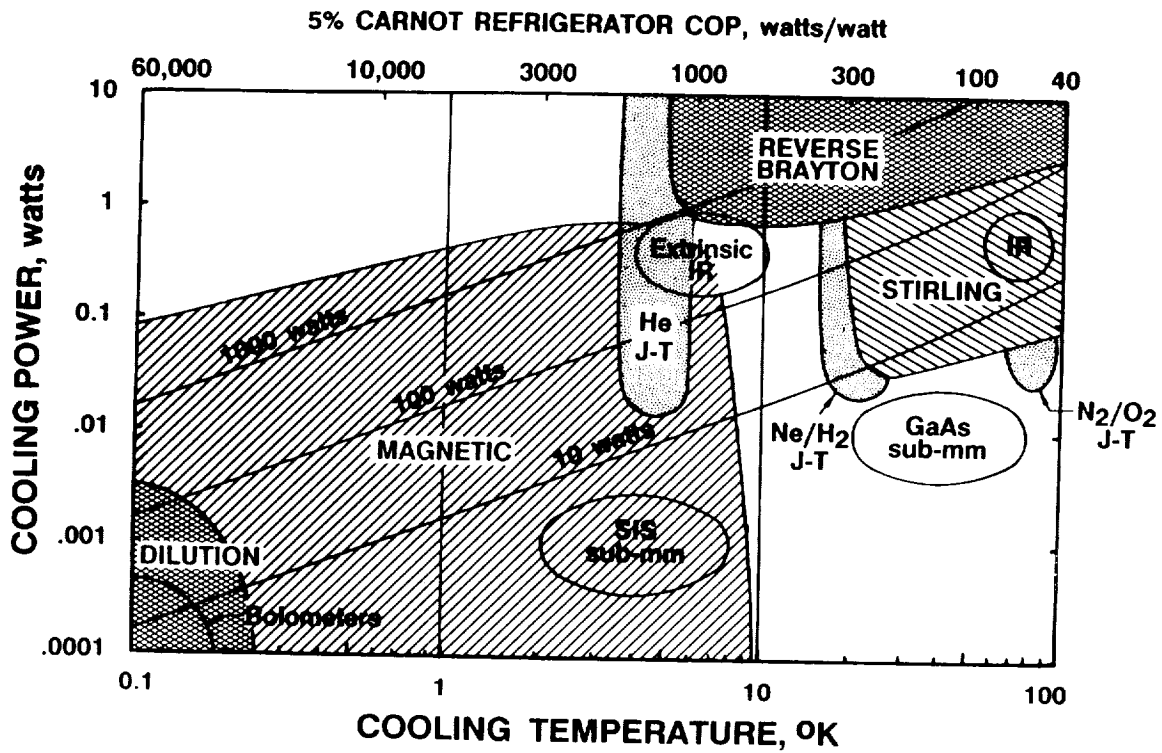

Figure 1. A compilation of the primary operating regions for various cryocooler technologies in terms of the cooling temperature and cooling power ranges they can each be expected to offer. Included for comparison are the operating ranges required for various detector types.

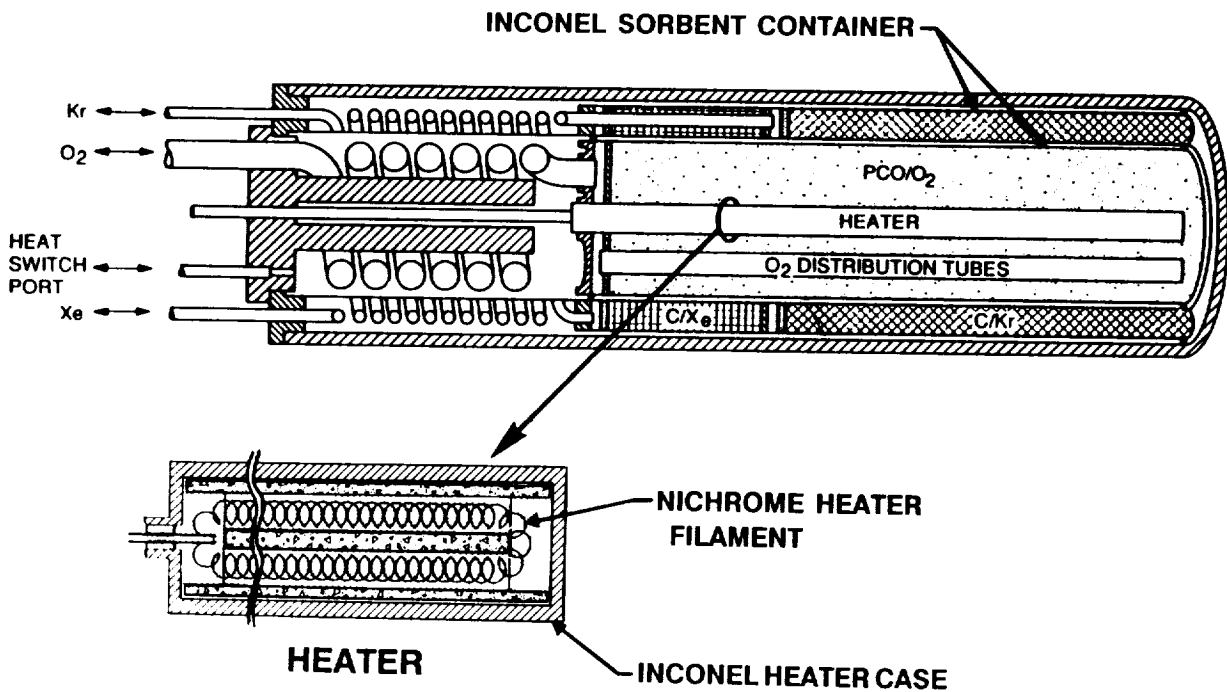

Figure 2. Schematic diagram of a concentric sorption compressor, a candidate for vibration-free cooling at 65 K.

**Table II. Technology Areas Recommended for Development**

Technology Area	Requirements	Missions	Freeze Date
Long-life, vibration-free refrigerator	10 - 20 K, 65-80 K.	HST, NAE Imag. Int, GRSO	'94 '04
2-5 K mechanical refrigerators	10-20 mW @ 2K, 50-100 mW at 4-5 K, < 1 kW input power.	SMILS NGOVLBI LDR, SMMI	'96 '00 '06
Flight testing of emerging prototypes	65 K Stirling, Subkelvin ADR, Others, as required.	Relevant to all missions	
R&D of backup technologies	Lower parasitic heat loads, alternate subkelvin concepts, alternate vibration-free concepts	Relevant to all missions	

**Table III. Long-Life Vibration-Free Refrigerators**

Technology Development	Current Technology	Program Goals	Program Dates	Program Size
Develop new approaches including sorption and turbo-Brayton	lab breadboard tests demonstrated feasibility	engineering model and life testing	91 - 93	Moderate
Qualify best option(s)		Space qualified model: for HST & NAE for NGST & GRSO	93-94 95 - 00	Large Large

**B. Development Plan**

It is recommended that one or two long-life low-vibration mechanical refrigerators be developed and qualified to provide 2 to 5 K cooling for future LDR-type applications that are beyond the reach of launch-vehicle limited SFHe Dewars such as used on SIRTf. A ball park target of less than 1 kW input power and 10 - 20 mW of cooling at 2 K together with 50 to 100 mW of additional cooling at 4 - 5 K was identified as about right. This distribution of cooling should be carefully reviewed in light of the thermodynamic inefficiency and immaturity of hardware for providing mechanical cooling at 2 K; the capacity at 2 K should be selected to just meet those science objectives requiring this temperature. Because of the vastly improved efficiency of providing cooling above the liquefaction point of He at 4 K, the science community should strive to meet as many objectives as possible using temperatures in the 4 to 5 K range or higher.

A variety of candidate technologies exist for providing 4 to 5 K mechanical cooling (Fig. 6).

These include: three-stage turbo-Brayton systems, closed-cycle He Joule-Thomson (J-T) refrigerators with upper stages, 4 K Stirling plus upper stages, and magnetic refrigerators with upper stages. Two-stage Stirling, pulse tube, and turbo-Brayton systems are candidate upper-stage technologies. Of these technologies for attaining 4 - 5 K, the three-stage turbo-Brayton is the most mature, having reached the prototype stage under DoD/SDIO funding. Because of the diversity of technical approaches, a multiple-path development approach is recommended, with down selection occurring after the definition of a preferred configuration. The proposed development schedule is summarized in Table IV.

Significant (x 10) expansion of superfluid He Dewar size and life performance beyond that for SIRTf was judged not to be a cost effective approach to meeting these most demanding Astrotech 21 missions. However, the SFHe technology is the logical choice for the smaller SIRTf-size missions.

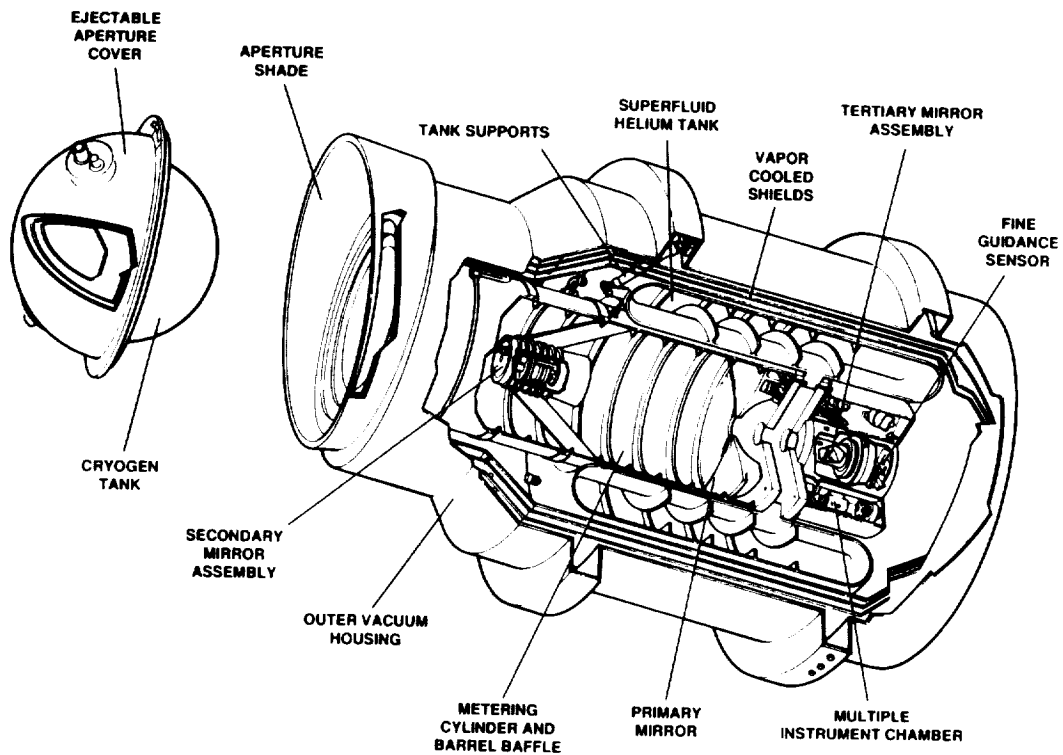

Figure 3. Schematic cut-away view of the plans for the SIRTf telescope displaying the cryogenic Dewar assembly.

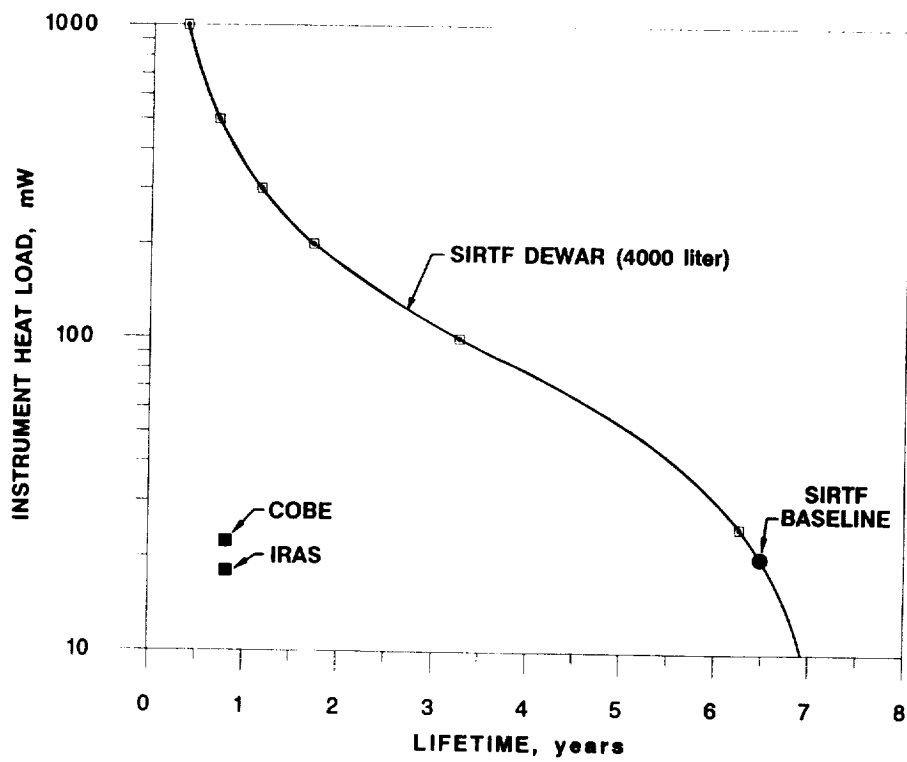

Figure 4. Plot of the instrument heat load that can be accommodated as a function of mission lifetime, assuming a 4,000 liter cryogen Dewar, as is planned for SIRTf.

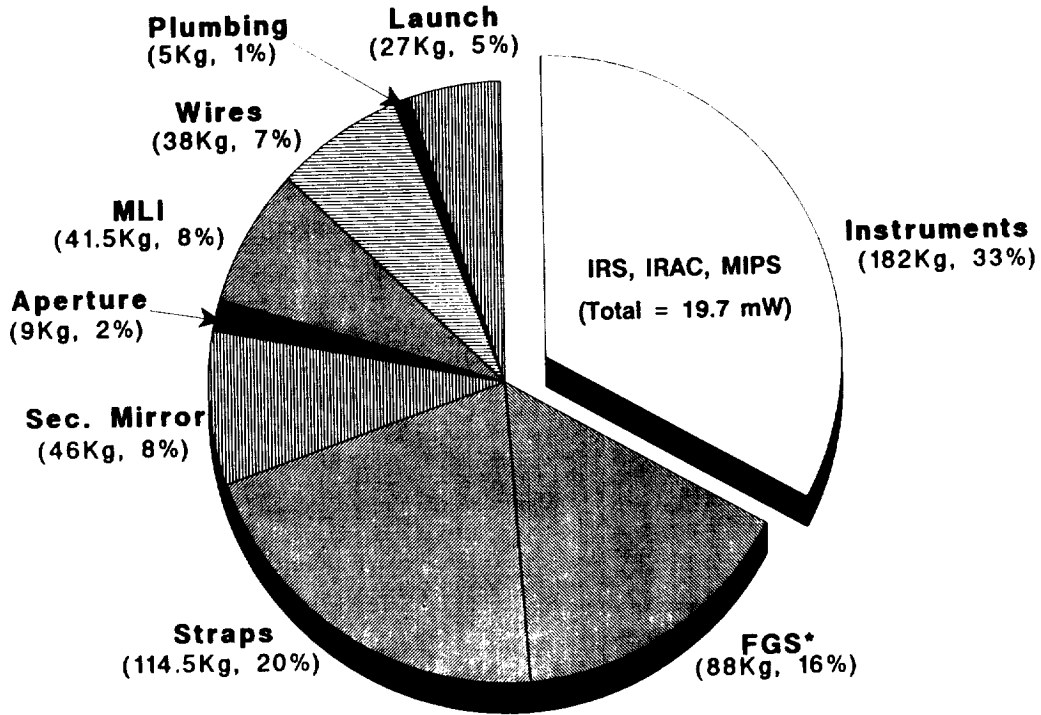

Figure 5. Breakdown of the heat load budget for a SIRTf-like mission displaying the relative contributions of different system components. FGS refers to the fine guidance system, and MLI to the multilayer insulation.

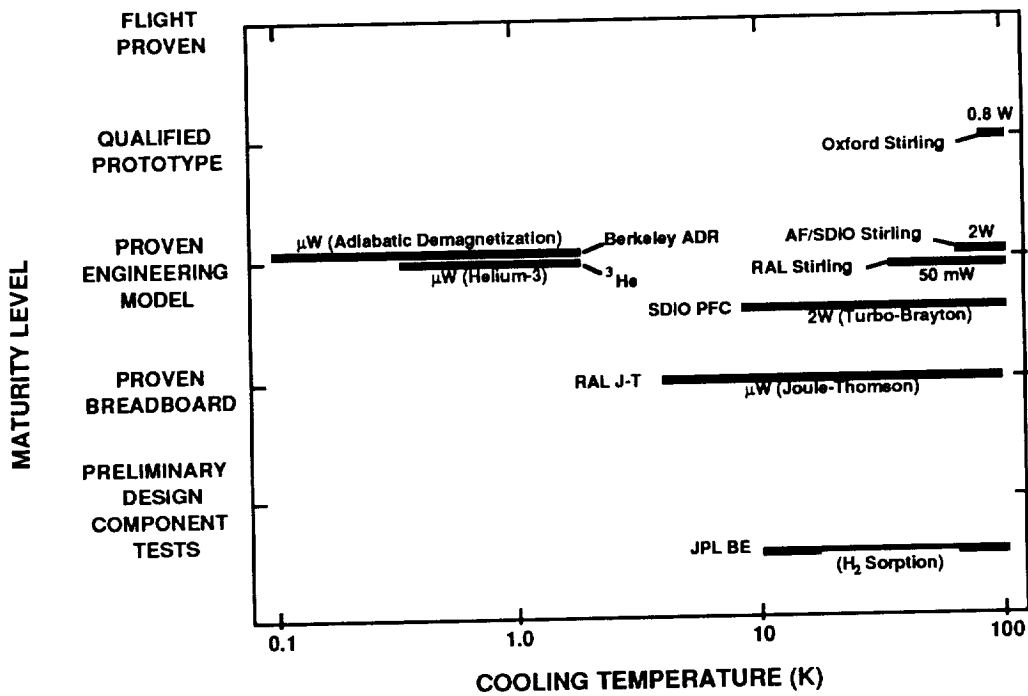

Figure 6. Maturity level of various mechanical cryocooler technologies versus their temperature range of operation.

**Table IV. Mechanical Refrigerators for 2 - 5 K**

Technology Development	Current Technology	Program Goals	Program Dates	Program Size
Explore multiple approaches	Prototype turbo-Brayton 2.5 W at 8.5 K 9 W at 25 K 80 W at 70 K ~ 3 kW input power	Feasibility for 2 - 5 K operation long life, low vibration	93 - 96	Several small
Develop best option(s)		10-20 mW at 2 K 50-100 mW at 4-5 K long life, low vibration	96 - 00	Large

**FLIGHT TESTING OF EMERGING PROTOTYPE REFRIGERATORS**

**A. Technology Assessment**

Because of the extreme challenges in achieving long-life mechanical refrigerators, a significant need was identified to qualify and flight test critical cooler technologies before they are committed to large high-visibility astrophysics missions that demand very low risk of failure.

**B. Development Plan**

To this end, it is recommended that a program of advanced development and flight testing be supported to help bridge the technology maturity gap between present cooler research activities and the demands of flight programs. As this time, 65 K low-vibration Stirling refrigerators and subkelvin adiabatic demagnetization refrigerators (ADR) are technologies in this category. The former are required for a number of missions, including the gamma-ray missions, which need low-vibration, high-capacity coolers in the 65 K temperature range. These applications will logically be met by the class of low-vibration Stirling (Fig. 7) and turbo-Brayton coolers currently under development for Eos and DOD, but not yet flight qualified. Subkelvin ADR systems are required for long-life subkelvin applications associated with the use of bolometers for IR and X-ray applications

which need ~ 10  $\mu$ W of cooling at 0.1 K with heat sinking at 2 K. Such refrigerators are under development (Fig. 8), but also need qualification and flight testing.

Other refrigerator technologies, as they reach this stage of development, would also greatly benefit from a pathfinder qualification and debugging phase in a low-risk (Class D) experiment setting. The panel recommends that this program be maintained at a moderate level throughout the development of new cooler capabilities required for Astrotech 21 missions, as indicated in Table V.

**R&D OF PROMISING BACKUP TECHNOLOGIES**

**A. Technology Assessment**

Although the above three program elements are necessary to achieve technology readiness for the Astrotech 21 mission set, it is not certain that they will be sufficient, and the parallel development of other promising backup technologies is strongly advised to mitigate against failure of one or more of the baseline technologies, and/or to take advantage of enabling improvements in current technologies. This is particularly relevant for large, high-visibility missions, such as many of these for astrophysics research, for which it is desirable to reduce the risk of failure to a very low level.

**Table V. Flight Testing of Emerging Prototype Refrigerators**

Technology Development	Current Technology	Program Goals	Program Dates	Program Size
Flight test experiments	New research-grade cooler technologies	Qualification and flight testing as Class D experiments	93 - 03	Moderate



Figure 7. Photograph of 80 K Stirling Cooler developed by British Aerospace from a prototype constructed at Oxford University. This cooler is currently being evaluated by JPL for Earth Observing Systems application.

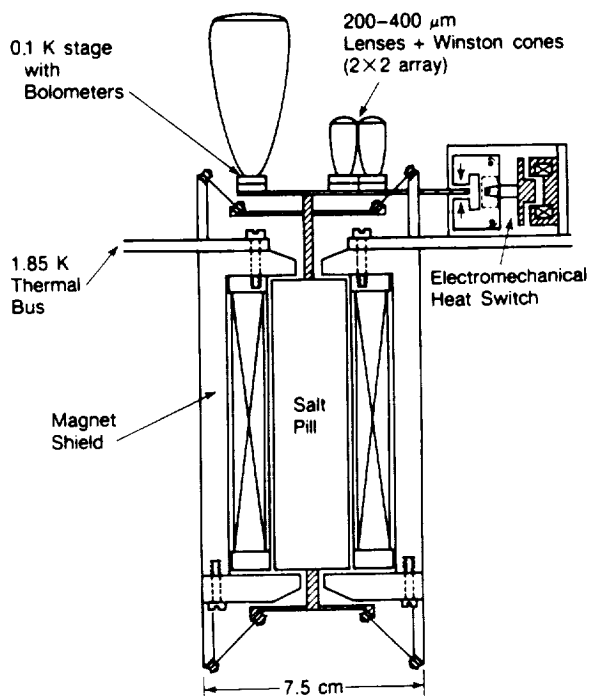

Figure 8. Schematic of prototype adiabatic demagnetization refrigerator (ADR) planned to provide subkelvin cooling for SIRTf bolometers.



**B. Development Plan**

With this concern in mind, the panel recommends that a program be initiated to support a number of promising backup technologies at relatively low levels. Example backup technologies that are of interest for the Astrotech 21 mission set include:

- Technologies that would significantly reduce parasitic heat loads into SFHe Dewars.
- Alternate refrigerator concepts for subkelvin cooling such as dilution and <sup>3</sup>He-<sup>4</sup>He Stirling technologies.
- Alternate vibration-free cooling concepts such as lower-temperature (80-100 K) thermoelectric coolers (TEC).
- Alternate low-vibration upper-stage coolers such as pulse-tube refrigerators.

This plan is summarized in Table VI.

**SUMMARY**

The Sensor Cooler Technology Panel identified four major areas in which technology development must be supported in order to meet the system performance requirements for the Astrotech 21 mission set science objectives. These are, in short:

- Long-life vibration-free refrigerators
- Mechanical refrigerators for 2-5 K

- Flight testing of emerging prototype refrigerators

A development strategy and schedule were recommended for each of the four areas.

Discussions between the cooler panel and other workshop panels also brought to light additional issues which should be considered by space scientists and detector instrument designers to optimize the total system performance. There are natural break points in operating temperature for space cooler technologies, such that the arbitrary selection of a sensor temperature just below one of these points can result in significant increases in cooler power requirements and in technical complexity, with concomitant increases in demands on the mission budget and in the risk of in-flight failure. An important break point for the Astrotech 21 mission set is at around 4 K, the liquefaction temperature of He. In addition, large cooling loads can be just as demanding of cooler technology as operating temperature requirements. Consequently, there are situations where it may be worthwhile sacrificing some small amount of signal to noise, and allowing the amplifier and/or readout electronics to operate at a different (higher) temperature than required for the sensors themselves, thereby reducing the heat load at the lowest temperatures. Similarly, efforts to improve thermal isolation technology, as recommended by the Sensor Readout Electronics Panel, are also supported by this panel.

**Table VI. R&D of Promising Backup Technologies**

Technology Development	Current Technology	Program Goals	Program Dates	Program Size
Approaches to reduce parasitic heat load into SFHe Dewars	Concepts	Feasibility	93 - 98	Small
Subkelvin coolers such as dilution and <sup>3</sup> He- <sup>4</sup> He Stirling technologies	Concepts	Feasibility	93 - 98	Small
Vibration-free approaches such as thermoelectric coolers	Concepts	Feasibility	93 - 98	Small
Low-vibration upper-stage coolers such as pulse-tube	Concepts	Feasibility	93 - 98	Small

## APPENDIX A. SENSOR TECHNOLOGY WORKSHOP PANELS AND CHAIRS

### X-Ray and Gamma-Ray Sensors Panel

Chair: A. Szymkowiak, *NASA Goddard Space Flight Center*

S. Collins, *Jet Propulsion Laboratory*  
J. Kurfess, *Naval Research Laboratory*  
W. Mahoney, *Jet Propulsion Laboratory*  
D. McCammon, *University of Wisconsin - Madison*  
R. Pehl, *Lawrence Berkeley Laboratory*  
G. Ricker, *Massachusetts Institute of Technology*

### Direct Infrared Sensors Panel

Chair: C. McCreight, *NASA Ames Research Center*

R. Bharat, *Rockwell International Science Center*  
R. Capps, *Jet Propulsion Laboratory*  
W. Forrest, *University of Rochester*  
A. Hoffman, *Hughes SBRC*  
H. Moseley, *NASA Goddard Space Flight Center*  
R. McMurray, *NASA Ames Research Center*  
M. Reine, *Loral Infrared and Imaging Systems*  
P. Richards, *University of California, Berkeley*  
D. Smith, *Los Alamos National Laboratory*  
E. Young, *University of Arizona*

### Sensor Readout Electronics Panel

Chair: E. Fossum, *Jet Propulsion Laboratory*

J. Carson, *Irvine Sensors*  
W. Kleinhans, *Valley Oak Semiconductor*  
W. Kosonocky, *New Jersey Institute of Technology*  
L. Kozlowski, *Rockwell International Science Center*  
A. Pecsalski, *Honeywell SRC*  
A. Silver, *TRW*  
A. Spieler, *Lawrence Berkeley Laboratory*  
J. Woolaway, *Amber Engineering*

### Ultraviolet and Visible Sensors Panel

Chair: J.G. Timothy, *Stanford University*

M. Blouke, *Tektronix, Inc.*  
R. Bredthauer, *LORAL (Ford)*  
R. Kimble, *NASA Goddard Space Flight Center*  
T.-H. Lee, *Eastman Kodak Corporation*  
M. Lesser, *Steward Observatory, University of Arizona*  
O. Siegmund, *University of California, Berkeley*  
G. Weckler, *EG&G Solid-State Products Group*

### Heterodyne Submm-Wave Sensors Panel

Chair: R. Wilson, *AT&T Bell Laboratories, Crawford Hill*

G. Chin, *NASA Goddard Space Flight Center*  
T. Crowe, *University of Virginia*  
M. Feldman, *University of Rochester*  
M. Frerking, *Jet Propulsion Laboratory*  
E. Kolberg, *California Institute of Technology*  
H. LeDuc, *Jet Propulsion Laboratory*  
T. Phillips, *California Institute of Technology*  
F. Ulaby, *University of Michigan Center for Space Terahertz Technology*  
W. Wilson, *Jet Propulsion Laboratory*  
J. Zmuidzinis, *California Institute of Technology*

### Sensor Cooler Technology Panel

Chair: R. Ross, *Jet Propulsion Laboratory*

S. Castles, *NASA Goddard Space Flight Center*  
N. Gautier, *California Institute of Technology*  
P. Kittel, *NASA Ames Research Center*  
J. Ludwigsen, *Nichols Research (SDIO)*

## APPENDIX B. ACRONYMS AND ABBREVIATIONS

The following tables are provided of all the acronyms and abbreviations utilized in the text of this Proceedings.

Space missions and instruments are listed in Table I, all other acronyms and abbreviations in Table II.

**TABLE I. SPACE MISSIONS AND INSTRUMENTS**

ACT	Advanced Compton Telescope (balloon instrument)	NAE	Nuclear Astrophysics Experiment
AIM	Astrometric Interferometer Mission	NGIR	Next Generation Infrared Mission
AXAF	Advanced X-Ray Astrophysics Facility	NICMOS	Near Infrared Camera & Multi-Object Spectrometer (HST II instrument)
COBE	Cosmic Background Explorer	NIMS	Near Infrared Mapping Spectrometer (Galileo instrument)
EGRET	Energetic Gamma-Ray Experiment Telescope (GRO instrument)	NGOVLBI	Next Generation Orbiting Very Long Baseline Interferometer
EUVE	Extreme Ultraviolet Explorer	NGST	Next Generation Space Telescope
FUSE	Far Ultraviolet Spectroscopic Explorer	ORI	Orbital Replacement Instrument (HST refurbishment instrument)
GP-B	Gravity Probe-B	OVLBI	Orbiting Very Long Baseline Interferometry
GRO	Gamma Ray Observatory	Radioastron	Soviet OVLBI mission
GRSO	Gamma-Ray Spectroscopy Observatory	SIRTF	Space Infrared Telescope Facility
HEAO	High Energy Astronomy Observatory	SMMI	Submillimeter Interferometer
HST	Hubble Space Telescope	SMIM	Submillimeter Intermediate Mission
HXIF	Hard X-Ray Imaging Facility	SOFIA	Stratospheric Observatory for Infrared Astronomy
Imag. Int.	Imaging Optical Interferometer	STIS	Space Telescope Imaging Spectrograph (HST II instrument)
IPC	Imaging Proportional Counter (HEAO II instrument)	SWAS	Submillimeter Wave Astronomy Satellite
IRAC	Infrared Array Camera (SIRTF instrument)	VHTF	Very High Throughput Facility
IRAS	Infrared Astronomical Satellite	VSOP	Japanese OVLBI mission
IRS	Infrared Spectrograph (SIRTF instrument)	WF/PC	Wide-Field and Planetary Camera (HST instrument)
LAGOS	Laser Gravity-Wave Observatory in Space	XST	X-Ray Schmidt Telescope
LDR	Large Deployable Deflector		
LTT	Lunar Transit Telescope		
MIPS	Multiband Imaging Photometer for SIRTF (SIRTF instrument)		

## APPENDIX B. ACRONYMS AND ABBREVIATIONS (Continued)

TABLE II. OTHER ACRONYMS AND ABBREVIATIONS

1/f noise	Fundamental noise with inverse frequency dependence	EUV	Extreme ultraviolet
1D	One dimensional (array)	f	frequency
2D	Two dimensional (array)	FET	Field-effect transistor
3D	Three dimensional (2D spatial array+ energy resolution)	FGS	Fine guidance system
A/D	Analog-to-digital converter	FPA	Focal-plane array
ADR	Adiabatic demagnetization refrigerator	h	Planck's constant
AGN	Active galactic nuclei	HEMT	High-electron-mobility transistor
AOS	Acousto-optic spectrometer	HIP	Heterojunction internal photoemission
AT	Advanced technology	HQ	Headquarters
BAe	British Aerospace	HTS	High-temperature superconductor
BIB	Blocked impurity band (same as IBC)	hv/k	Quantum limit for mixer sensitivity
BLIP	Background-limited performance	IBC	Impurity band conduction (same as BIB)
BW	Bandwidth	IF	Intermediate frequency (mixer output signal)
BWO	Backward-wave oscillator	IR	Infrared
CCD	Charge-coupled device	JFET	Junction field-effect transistor
CHIGFET	Complementary heterojunction insulated-gate FET	J-T	Joule-Thomson (refrigerator)
CID	Charge-injection device	k	Thousand, or Boltzmann constant
COP	Coefficient of performance	kTC noise	Noise associated with reset through capacitor, C
CSTI	Civil Space Technology Initiative (NASA)	LB	Low background
CTE	Charge transfer efficiency (CCD readout)	LHe	Liquid helium
CTIA	Capacitive trans-impedance amplifier	LN2	Liquid nitrogen
D*	Detectivity	LO	Local oscillator
DoD	Department of Defense (US)	LWIR	Long-wavelength infrared
demo.	Demonstration	M	Million
e <sup>-</sup>	electron	MAMA	Multi-anode microchannel array
E	Energy	MB	Moderate background
E/ΔE	Energy resolution	MCP	Microchannel plate
EMI	Electromagnetic interference	MLI	Multilayer insulation
E res.	Energy resolution	MODIL	Manufacturing Operations, Development and Integration Laboratory (SDIO)
EO	Earth orbit	MOS	Metal-oxide-semiconductor
EO/Mn	Earth orbit or Moon	MUX	Multiplexer

## APPENDIX B. ACRONYMS AND ABBREVIATIONS (Continued)

TABLE II. OTHER ACRONYMS AND ABBREVIATIONS (Continued)

NEP	Noise-equivalent power	SDI	(Or SDIO) Strategic Defense Initiative Organization
OAET	Office of Aeronautics, Exploration and Technology (NASA Headquarters)	semicond.	Semiconductor
PMT	Photomultiplier tube	SFHe	Superfluid helium
preamp.	preamplifier	SIN	Superconductor-insulator-normal metal
osc.	Oscillator	SIS	Superconductor-insulator-superconductor
OSSA	Office of Space Science and Applications (NASA HQ)	SQUID	Superconducting quantum interference device
PC	Photoconductive	SSPM	Solid-state photomultiplier
PMOS	P-type metal-oxide-semiconductor	STIS	Space Telescope Imaging Spectrograph (HST instrument)
PMT	Photomultiplier tube	submm	Submillimeter
pos. res.	Position resolution	supercond.	Superconductor
PC	Photoconductive	SWIR	Short-wavelength infrared
PV	Photovoltaic	$T_c$	Critical temperature (superconducting transition temperature)
QE	Quantum efficiency	TEC	Thermoelectric cooler
QW	Quantum well	TIA	Trans-impedance amplifier
QWIP	Quantum-well infrared photodetector	UV	Ultraviolet
req.	Requirement	u-v plane	telescope pupil (aperture) plane
res.	Resolution	VLBI	Very long baseline interferometer
Rm. T	Room temperature	VLSI	Very large scale integrated circuits
SBD	Schottky barrier device	VLWIR	Very long wavelength infrared
SBRC	Santa Barbara Research Center (Hughes)		