

-9-33

104485

P-7

N92-29373

Improvements in X-Band Transmitter Phase Stability Through Klystron Body Temperature Regulation

R. M. Perez

Radio Frequency and Microwave Subsystems Section

This article describes the techniques used and experimental results obtained in improving transmitter stability by control of the klystron body temperature. Related work in the measurement of klystron phase control parameters (pushing factors) is also discussed. The contribution of waveguide temperature excursions to uplink phase stability is presented. Suggestions are made as to the direction of future work in this area.

I. Introduction

Long-term spacecraft tracking-link phase stability is an important parameter in the detection of gravity waves by Doppler methods. This link phase stability requirement dictated reducing the phase stability contribution of the DSN 20-kW X-band (7.167-GHz) uplink microwave transmitters to an Allan deviation of 5×10^{-15} for a 1000-second averaging period. This requirement was met in the DSN 20-kW X-band transmitters¹ by closely regulating the klystron cathode voltage. It was desired to decrease this figure by an order of magnitude to 1×10^{-16} to allow future operation with improved phase stability.

To achieve this goal a two-part approach was followed, which consisted of identifying and measuring the magnitude of the klystron phase-pushing factors and control-

ling those found to be significant contributors. Most prior transmitter phase stability improvement work has been concentrated on improving the klystron cathode (beam) voltage regulation, since the large effect of this parameter on the phase of the transmitter output signal is well established [1]. Efforts in this area have succeeded in regulating the beam voltage to about 0.01 percent over an 8-hour period and to nearly 0.003 percent over 1000 seconds, resulting in a beam voltage-induced phase shift on the order of 0.1 degree over eight hours of operation. In view of this, it was decided to concentrate on controlling other causes of phase instability.

II. Measurement of Phase-Pushing Factors

To establish the magnitude of the phase-pushing factors of the Varian 876P klystron used in the DSN 20-kW X-band transmitters, a measurement system (see Fig. 1) was configured. This system allows the independent variation of klystron operating parameters and the measure-

¹ R. Perez, "DSS 15 20 kW X-band Transmitter Test Results Regarding Stability Requirements," Interoffice Memorandum 3337-89-098 (internal document), Jet Propulsion Laboratory, Pasadena, California, October 3, 1989.

ment of subsequent changes in output signal phase. An HP 8510A network analyzer was used as the phase detector in conjunction with a coaxial switch, which enabled sampling of the phase of the klystron input and output signals and of a reference coaxial line. In this manner a differential phase measurement was made by using the phase of the reference line signal and the klystron input signal to normalize the phase of the klystron output signal. This resulted in the removal of any output signal phase fluctuations due to input signal or instrumentation instabilities from the phase-pushing factor data. Measurement of klystron operating parameters and temperatures was performed coherently with each phase measurement to permit later analysis. It should be noted that this configuration enabled control of the klystron body coolant temperature independent of the remaining cooling circuits and permitted the direct measurement of the klystron body temperature phase-pushing factor for the first time.

The magnitude of output signal phase fluctuation due to stimulus change was then measured for the following klystron parameters: beam voltage, drive RF level, body temperature, filament current, and focusing electromagnetic current. The results of these measurements may be found in Table 1.

III. Measurement of Phase Stability

After performing the pushing-factor measurements above, it was found that the klystron body temperature fluctuations showed the largest phase pushing of the parameters described above, given the typical operational variations encountered for each parameter. To stabilize the temperature of the klystron body, a refrigerated chiller (Neslab HX-75) capable of regulating the coolant temperature to 0.1 deg C was purchased. A system was then assembled (see Fig. 2) to perform long-term transmitter phase stability measurements (see [2] for a description of the stability measurement system-operating principles).

Phase stability measurements were then performed under two conditions: cooling the klystron body with the system heat exchanger and independent body cooling with the Neslab HX-75 refrigerated chiller. The results of these measurements may be found in Fig. 3 in the form of Allan deviations.

IV. Discussion of Results

The measurement of the klystron pushing factors revealed some significant points:

- (1) The klystron output signal phase is most strongly affected by fluctuations in the beam voltage, with a value of 45 deg/kV; however, given the tight regulation of the beam power supply in the DSN 20-kW X-band transmitters, the beam voltage phase-pushing contribution becomes secondary to other factors.
- (2) No phase pushing was detected due to changes in the klystron-focusing electromagnetic current or filament current. This should not be taken to mean that phase pushing by these parameters is not possible; rather, no phase change was observed due to a ± 10 percent change in focusing current and filament current, and a phase measurement resolution on the order of 0.1 degree. Wider excursions in these parameters carry a risk of exceeding the operating ratings of the klystron with ensuing damage. Normal drift of these parameters in operation is on the order of 1 to 2 percent; thus, it is unlikely that filament or focusing-current instabilities significantly affect overall transmitter stability.
- (3) The temperature of the klystron body is a strong phase-pushing factor (see Fig. 4), with a value of 0.9 deg/deg C. It can be seen that given typical heat exchanger temperature fluctuations in the 5-deg-C range, this becomes the dominant klystron output phase-pushing factor in the presence of a tightly regulated beam voltage.
- (4) A relationship was noticed between the output signal phase and the temperature of the transmitter output waveguide coolant. An analysis of the phase shift due to thermal expansion of the waveguide was performed (see Appendix), which confirmed this hypothesis. The expected phase pushing by waveguide temperature fluctuations agrees closely with the measured values (see Fig. 5).
- (5) Cooling the klystron body independently with the Neslab HX-75 chiller resulted in a marked improvement in transmitter phase stability, particularly in the 10^2 - to 10^4 -second region critical to gravity wave detection [3]. At a 1000-second averaging time, the Allan deviation changed from $\sigma = 3.25 \times 10^{-16}$ without body temperature control to $\sigma = 5.88 \times 10^{-17}$ with body temperature control (see Fig. 3).
- (6) A simulation was performed to investigate the extent to which the klystron pushing factors thus far identified account for the overall transmitter phase stability performance. The point-to-point variation in each parameter (beam voltage, body temperature, and waveguide temperature) from the test time series record was multiplied by its respective phase-pushing factor to obtain the phase step produced by

changes in each parameter. These phase changes were added algebraically to produce a composite phase file, the Allan variance of which was computed. It is postulated that the difference between the Allan variance of the synthetic phase file and the Allan variance measured for the whole transmitter is due to phase-pushing factors other than the variations in klystron beam voltage, body temperature, and waveguide temperature. A comparison of the results may be seen in Fig. 6. Note that the performance of the simulated transmitter (using only beam voltage and body and waveguide temperatures) is significantly superior to that of the actual transmitter, particularly for averaging times greater than 10 seconds. This strongly suggests that future gains in long-term transmitter phase stability are to be made by concentrating on components other than the klystron (the klystron filament and focus currents have no measured impact on output phase, as mentioned above). For example, examination of the

phase stability of the RF control components and driver amplifier regarding temperature and possibly control voltages is likely to be fruitful. The amplitude stability of these components should also be examined, due to amplitude modulation-phase modulation (AM-PM) conversion in a saturated klystron.

V. Conclusion

The phase-pushing factors of the Varian 876P klystron used in the DSN 20-kW X-band transmitters have been measured. Tight temperature regulation of the klystron body temperature has resulted in appreciably improved transmitter phase stability, surpassing the goal of $\sigma = 1 \times 10^{-16}$ to 5.88×10^{-17} for the 1000-second averaging time set for the task. The effect of waveguide temperature changes on the phase of the transmitter output signal has been identified and verified analytically. Some promising areas for future work in transmitter stability improvement have been suggested.

References

- [1] R. Kolby, "Evaluation of the VA876P Klystron for the 20-kW X-Band Uplink Transmitter," *DSN Progress Report 42-54*, vol. September-October, Jet Propulsion Laboratory, Pasadena, California, pp. 41-50, September 1979.
- [2] B. Conroy and D. Le, "Simultaneous Measurement of Allan Variance and Phase Noise Spectrum at Fractions of a Millihertz," *Review of Scientific Instruments*, vol. 61, no. 6, pp. 1720-1723, June 1990.
- [3] S. Nelson and J. Armstrong, "Gravitational Wave Searches Using the DSN," *TDA Progress Report 42-94*, vol. April-June 1988, Jet Propulsion Laboratory, Pasadena, California, pp. 75-85, August 15, 1988.

Table 1. Phase-pushing factors for the Varian 876P klystron.

Parameter	Phase-pushing factor
Beam voltage, deg/V	0.045
Drive level, deg/dB	2.3
Body temperature, deg/deg C	0.9
Filament current	None measured
Focusing current	None measured

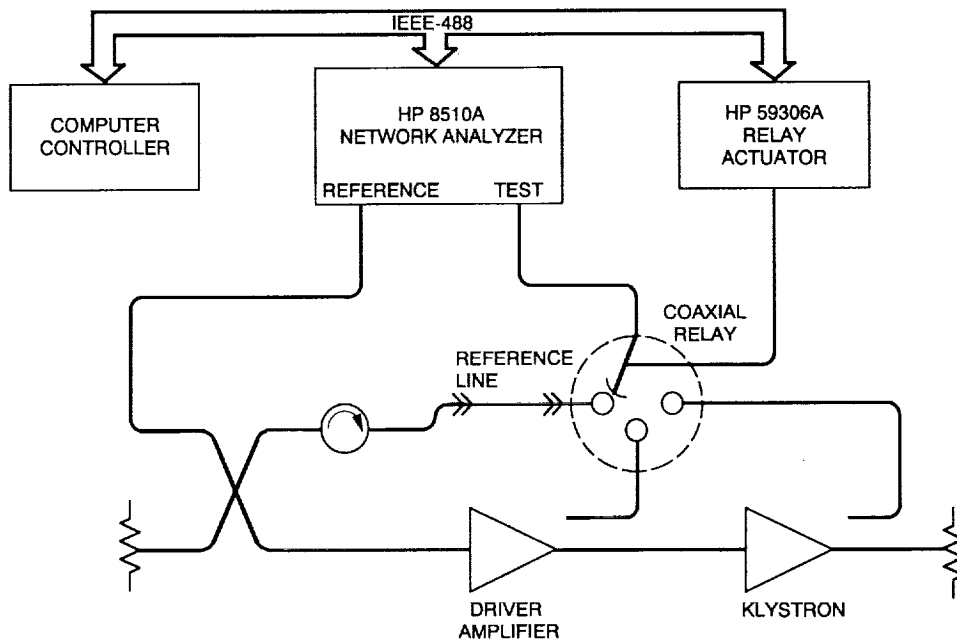

Fig. 1. Phase-pushing factor measurement system.

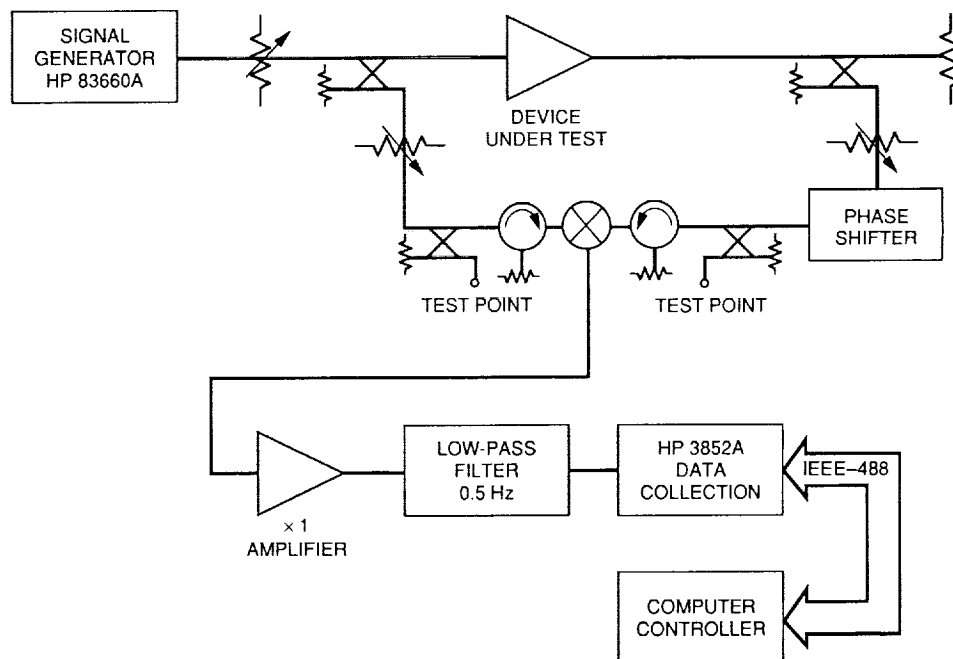

Fig. 2. Phase stability measurement system.

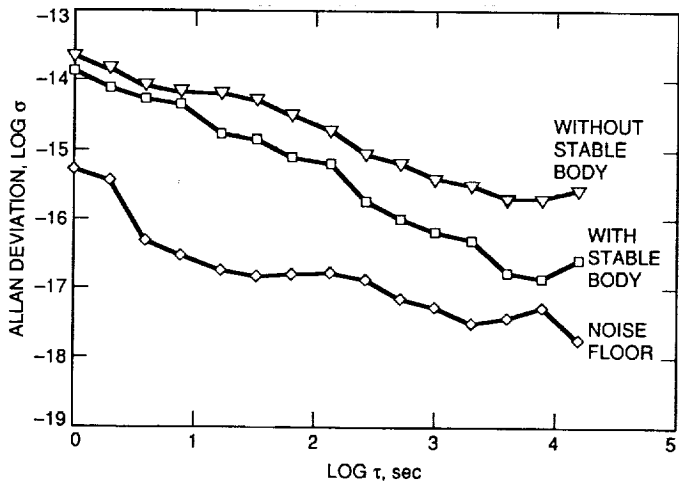

Fig. 3. Transmitter phase stability improvement.

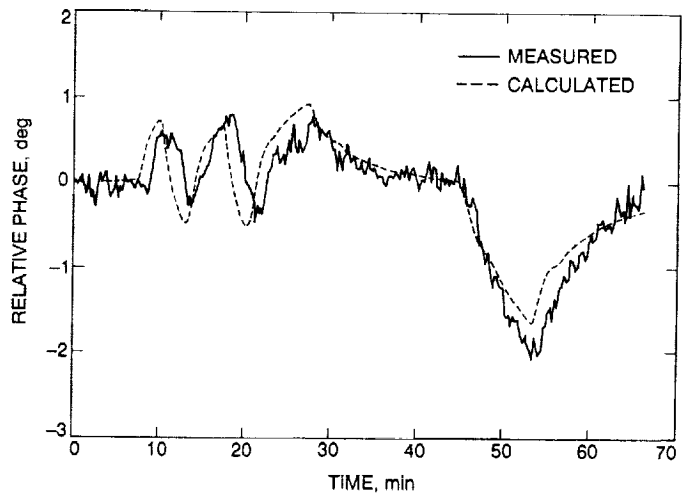

Fig. 5. Phase shift due to waveguide temperature fluctuations.

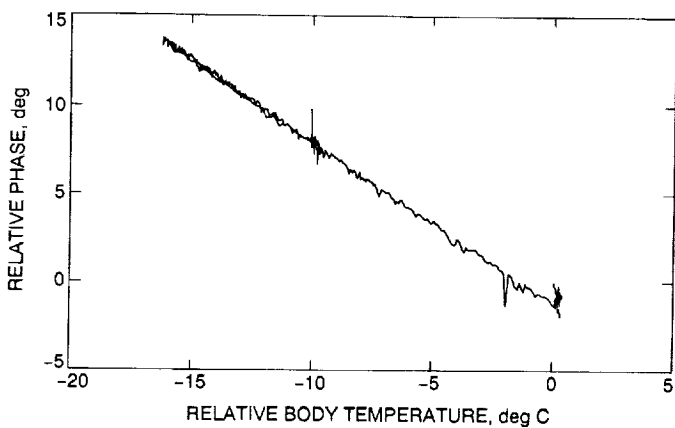

Fig. 4. Klystron body temperature pushing of phase.

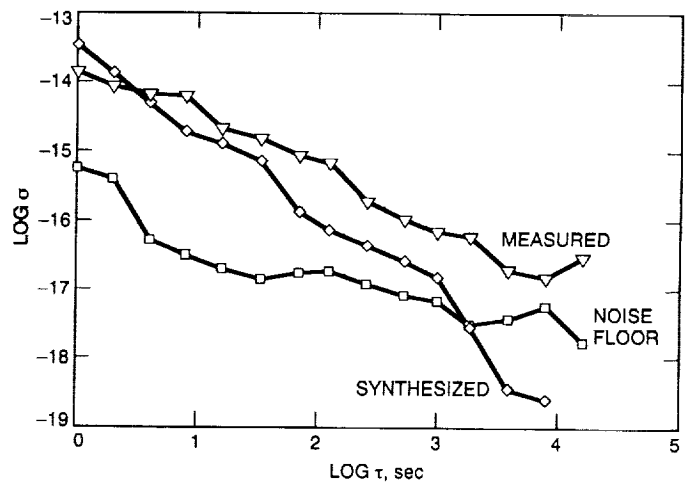

Fig. 6. Comparison of measured and synthesized Allan variances.

Appendix

Phase Shift of a Signal Due to Waveguide Temperature Changes

The guide wavelength of a signal in a rectangular waveguide and $TE_{1,0}$ mode is

$$\lambda_i = \frac{\lambda_0}{\sqrt{1 - \left(\frac{\lambda_0}{2A}\right)^2}} \quad (\text{A-1})$$

where

λ_0 = free space wavelength

A = waveguide width

The phase shift for a waveguide of length l is

$$\phi_i = 360 \frac{l}{\lambda_i} \text{ deg} \quad (\text{A-2})$$

Given a thermal expansion coefficient for the waveguide material and a temperature change of ΔT , the resulting waveguide width change is

$$\Delta A = A\rho\Delta T \quad (\text{A-3})$$

where

ρ = thermal expansion coefficient in ppm/C

ΔT = temperature change in deg C

which results in a new guide wavelength:

$$\lambda_f = \frac{\lambda_0}{\sqrt{1 - \left(\frac{\lambda_0}{2A + 2\Delta A}\right)^2}} \quad (\text{A-4})$$

Likewise, the length of the waveguide section changes by

$$\Delta l = l\rho\Delta T \quad (\text{A-5})$$

The expanded waveguide has a phase shift of

$$\phi_f = 360 \frac{l + \Delta l}{\lambda_f} \text{ deg} \quad (\text{A-6})$$

The phase shift induced by the temperature change is then

$$\Delta\phi = \phi_f - \phi_i \quad (\text{A-7})$$

By substituting Eqs. (A-2) and (A-4) and simplifying,

$$\Delta\phi = 360 \left(\frac{l + \Delta l}{\lambda_f} - \frac{l}{\lambda_i} \right) \text{ deg} \quad (\text{A-8})$$