

7/5-32 ✓

104291

p-9

N92-29379

Bandwidth Compression of Noisy Signals With Square-Wave Subcarrier

Y. Fera and J. Statman

Communications Systems Research Section

This article discusses a method for downconverting the square-wave subcarrier of spacecraft signals, such as the one from Galileo, which results in a compression bandwidth that lowers the sample rate significantly. The study is focused on three issues. The first is the selection of an adequate down-mixing signal for the resulting signal to have a format similar to that of the original signal, except at a lower subcarrier frequency. The second is the control of the noise level so that the signal to noise ratio is not degraded due to the downconversion. The third is to determine the bandwidth of the downconverted signal considering the uncertainty of the residual carrier frequency.

I. Introduction

A typical downconverted spacecraft signal (e.g., the Galileo signal) has a square-wave subcarrier whose frequency is much higher than the modulating data bandwidth, as shown in Fig. 1 (a). Note that the residual carrier frequency is much smaller than the subcarrier frequency and is not necessarily zero, which results in the dual spectra centered at $-f_r$ and $+f_r$. If the signal is sampled at this point, the sample rate needs to be at least twice the frequency of the highest harmonic considered to have a significant amount of power, plus the residual carrier frequency and the single-sided data bandwidth. This implies that excessive equipment is needed for data processing and storage. For limited resources, this may even mean loss of data. On the other hand, if the square-wave subcarrier could be downconverted to a much lower fre-

quency, as shown in Fig. 1 (b), then the sample rate can be reduced significantly, which leads to a smaller amount of data storage and more efficient data processing.

This article presents a method to downconvert the square-wave subcarrier, which includes finding a down-mixing signal and controlling the noise level. In the next section, the downconversion in the absence of noise will be studied. This will be followed by an analysis that considers noise.

II. Downconversion in the Absence of Noise

In order to use the existing telemetry recovery equipment, the downconverted subcarrier needs to preserve the

square-wave form at a lower subcarrier frequency. This can be achieved by a downconverting procedure shown in Fig. 2 (a), where the mixing signal $y(t)$ and the parameters of the lowpass filter (LPF) need to be carefully chosen.

A. Downconversion of the Subcarrier

The square-wave subcarrier, $D_2(t)$, can be represented in its Fourier series form, assuming that $D_2(t)$ has a unit amplitude and phase angle, θ_{sc} :

$$D_2(t) = \frac{4}{\pi} \sum_{n=1}^{\infty} \frac{1}{2n-1} \sin[(2n-1)(\omega_{sc}t + \theta_{sc})] \quad (1)$$

where $\omega_{sc} = 2\pi f_{sc}$.

In a practical system, it suffices to consider only a small number of terms of $D_2(t)$, typically up to the third or fifth harmonic because the power in the higher harmonics diminishes quickly.

Mixing $D_2(t)$ down can be achieved by multiplying $D_2(t)$ by a signal, $y(t)$, and then passing the product, $g_1(t) = D_2(t)y(t)$, through a low-pass filter, as shown in Fig. 2 (a). Assuming that the signal, $y(t)$, has the form

$$\begin{aligned} y(t) &= 2 \operatorname{sgn}(\omega_{sc} - \omega_1) \sum_{m=1}^N \cos[(2m-1)(\omega_1t + \theta_1)] \\ &= 2 \operatorname{sgn}(\omega_{sc} - \omega_1) \cos(\omega_1t + \theta_1) \\ &\quad + \cos 3(\omega_1t + \theta_1) + \cos 5(\omega_1t + \theta_1) \\ &\quad + \dots + \cos[(2N-1)(\omega_1t + \theta_1)] \end{aligned} \quad (2)$$

where $|\omega_{sc} - \omega_1|$ is very small. Note that Eq. (2) is not a Fourier expansion of a square wave. The authors will show that this signal can mix the square-wave subcarrier down to a much lower frequency.

Note that $y(t)$ can only have a finite number of terms to ensure convergence. This implies that the downconverted signal will not be a true square wave, instead only N number of harmonics will remain, with the highest harmonic being the $2N-1$. In the remainder of the discussion, it will be assumed that $N \leq 3$. By expanding $g_1(t) = D_2(t)y(t)$, one obtains

$$\begin{aligned} g_1(t) &= \left[\frac{4}{\pi} \sum_{n=1}^{\infty} \frac{1}{2n-1} \sin[(2n-1)(\omega_{sc}t + \theta_{sc})] \right] 2 \operatorname{sgn}(\omega_{sc} - \omega_1) [\cos(\omega_1t + \theta_1) + \cos 3(\omega_1t + \theta_1) + \cos 5(\omega_1t + \theta_1)] \\ &= \operatorname{sgn}(\omega_{sc} - \omega_1) \frac{4}{\pi} \left\{ \sin[(\omega_{sc} - \omega_1)t + \theta_{sc} - \theta_1] + \frac{1}{3} \sin 3[(\omega_{sc} - \omega_1)t + \theta_{sc} - \theta_1] + \frac{1}{5} \sin 5[(\omega_{sc} - \omega_1)t + \theta_{sc} - \theta_1] \right. \\ &\quad + \sin[(\omega_{sc} - 3\omega_1)t + \theta_{sc} - 3\theta_1] + \sin[(\omega_{sc} - 5\omega_1)t + \theta_{sc} - 5\theta_1] + \sin[(\omega_{sc} + \omega_1)t + \theta_{sc} + \theta_1] \\ &\quad + \sin[(\omega_{sc} + 3\omega_1)t + \theta_{sc} + 3\theta_1] + \sin[(\omega_{sc} + 5\omega_1)t + \theta_{sc} + 5\theta_1] + \frac{1}{3} \sin[(3\omega_{sc} - \omega_1)t + 3\theta_{sc} - \theta_1] \\ &\quad + \frac{1}{3} \sin[(3\omega_{sc} + \omega_1)t + 3\theta_{sc} + \theta_1] + \frac{1}{3} \sin[(3\omega_{sc} + 3\omega_1)t + 3\theta_{sc} + 3\theta_1] + \frac{1}{3} \sin[(3\omega_{sc} - 5\omega_1)t + 3\theta_{sc} - 5\theta_1] \\ &\quad + \frac{1}{3} \sin[(3\omega_{sc} + 5\omega_1)t + 3\theta_{sc} + 5\theta_1] + \frac{1}{5} \sin[(5\omega_{sc} - \omega_1)t + 5\theta_{sc} - \theta_1] + \frac{1}{5} \sin[(5\omega_{sc} + \omega_1)t + 5\theta_{sc} + \theta_1] \\ &\quad \left. + \frac{1}{5} \sin[(5\omega_{sc} - 3\omega_1)t + 5\theta_{sc} - 3\theta_1] + \frac{1}{5} \sin[(5\omega_{sc} + 3\omega_1)t + 5\theta_{sc} + 3\theta_1] + \frac{1}{5} \sin[(5\omega_{sc} + 5\omega_1)t + 5\theta_{sc} + 5\theta_1] + \dots \right\} \end{aligned} \quad (3)$$

By passing $D_2(t)y(t)$ through a lowpass filter with a proper cutoff frequency, the first three terms will remain.

$$z_1(t) = \operatorname{sgn}(\omega_{sc} - \omega_1) \frac{4}{\pi} \left\{ \sin [(\omega_{sc} - \omega_1)t + \theta_{sc} - \theta_1] + \frac{1}{3} \sin 3 [(\omega_{sc} - \omega_1)t + \theta_{sc} - \theta_1] + \frac{1}{5} \sin 5 [(\omega_{sc} - \omega_1)t + \theta_{sc} - \theta_1] \right\} \quad (4)$$

which is similar to $D_2(t)$ except at a lower frequency.

The downconverting procedure can clearly be shown by using the following numerical example: The square-wave subcarrier that is used in the signal from Galileo has a fundamental frequency, 22.5 KHz, and it can be represented by the first three harmonics, assuming the phase of the subcarrier, $\theta_{sc} = 0$,

$$D_2(t) = \sin(22.5 \times 2\pi t) + \frac{1}{3} \sin(67.5 \times 2\pi t) + \frac{1}{5} \sin(112.5 \times 2\pi t)$$

Considering down-mixing $D_2(t)$ with a signal of the form shown in Eq. (2), where $\omega_1 = 24.75 \times 2\pi$ and $N = 3$

$$y(t) = -2 \cos(24.75 \times 2\pi t) - 2 \cos(74.25 \times 2\pi t) - 2 \cos(123.75 \times 2\pi t)$$

The product of $D_2(t)$ and $y(t)$ is

$$g_1(t) = D_2(t)y(t) = \sin(2.25 \times 2\pi t) + \frac{1}{3} \sin(6.75 \times 2\pi t) + \frac{1}{5} \sin(11.25 \times 2\pi t) - \frac{1}{5} \sin(38.25 \times 2\pi t) - \frac{1}{3} \sin(42.75 \times 2\pi t) - \sin(47.25 \times 2\pi t)$$

$$+ \sin(51.75 \times 2\pi t) + \frac{1}{3} \sin(56.25 \times 2\pi t) - \frac{1}{5} \sin(87.75 \times 2\pi t) - \frac{1}{3} \sin(92.25 \times 2\pi t) - \sin(96.75 \times 2\pi t) + \sin(101.25 \times 2\pi t) - \frac{1}{5} \sin(137.25 \times 2\pi t) - \frac{1}{3} \sin(141.75 \times 2\pi t) - \sin(146.25 \times 2\pi t) - \frac{1}{5} \sin(186.75 \times 2\pi t) - \frac{1}{3} \sin(191.25 \times 2\pi t) - \frac{1}{5} \sin(236.25 \times 2\pi t)$$

where t is in milliseconds. It is clear that if an ideal lowpass filter is used with a cutoff frequency, f_L , being $11.25 \text{ KHz} < f_L < 38.25 \text{ KHz}$, then the output becomes

$$z_1(t) = \sin(2.25 \times 2\pi t) + \frac{1}{3} \sin(6.75 \times 2\pi t) + \frac{1}{5} \sin(11.25 \times 2\pi t)$$

which is similar to $D_2(t)$, except that the fundamental frequency is reduced from 22.5 to 2.25 KHz. Clearly, if the subcarrier is modulated by a slow-changing data sequence, a similar downconversion can occur.

It is important to notice that the resulting waveform represents a square wave due to the maintenance of proper frequency, phase, and amplitude relationships. It is distorted only by the truncation of the sequence to a finite length.

B. Downconversion of Subcarrier in the Presence of Data and a Residual Carrier

In the case where the residual carrier and the data are present, a typical downconverted spacecraft signal has in-phase and quadrature components of the form

$$x(t) = A \sin(\omega_r t + \theta_r) + B D_1(t) D_2(t) \cos(\omega_r t + \theta_r)$$

where A and B denote the amplitudes, $\omega_r = 2\pi f_r$ is the angular frequency of the residual carrier, $D_1(t)$ is the data

with bandwidth B_1 , and $D_2(t)$ is the square-wave subcarrier with the frequency, f_{sc} . Without loss of generality, one assumes the residual carrier phase angle to be zero ($\theta_r = 0$) in the discussion that follows.

To keep the residual carrier present after the downconversion, the downconverting signal, $y(t)$, needs to be added to 1, as shown in Fig. 2 (b).

The lowpass filter input can be written as

$$\begin{aligned} g_2(t) &= x(t)[y(t) + 1] \\ &= x(t)y(t) + x(t) \\ &= A \sin(\omega_r t) + BD_1(t)D_2(t) \cos(\omega_r t) \\ &\quad + A \sin(\omega_r t)y(t) + BD_1(t)D_2(t) \cos(\omega_r t)y(t) \end{aligned} \quad (5)$$

The first term on the right-hand side of Eq. (5) is the residual carrier with a very low frequency which will remain after low-pass filtering. The second and the third terms are centered on f_{sc} and f_1 , respectively. Both f_{sc} and f_1 are much higher than $5|f_{sc} - f_1|$, which is the highest frequency of the desired terms, so the second and the third terms can be filtered out. The last term is

$$[BD_1(t) \cos(\omega_r t)] \times [D_2(t)y(t)]$$

Passing $D_2(t)y(t)$ through an LPF results in $z_1(t)$, as shown in Section II.A; passing the product through the LPF will result in $BD_1(t) \cos(\omega_r t)z_1(t)$, since $BD_1(t) \cos(\omega_r t)$ has a narrow bandwidth.

In the overall picture, the resulting LPF output, $z_2(t)$, is

$$\begin{aligned} z_2(t) &= A \sin(\omega_r t) + BD_1(t) \cos(\omega_r t) \\ &\quad \times [\sin(|\omega_{sc} - \omega_1|t + \theta) + \frac{1}{3} \sin 3(|\omega_{sc} - \omega_1|t + \theta) \\ &\quad + \frac{1}{5} \sin 5(|\omega_{sc} - \omega_1|t + \theta)] \end{aligned} \quad (6)$$

where $\theta = \theta_{sc} - \theta_1$. The obtained output is similar to the original signal, $x(t)$, except that the fundamental frequency of the subcarrier in $z_2(t)$ is much lower than that

in $x(t)$, the phase has been shifted from θ_{sc} to $\theta_{sc} - \theta_1$, and the subcarrier in $z_2(t)$ does not have an infinite number of terms.

C. Conditions on the Down-Mixing Signal Frequency

One condition on the down-mixing-signal frequency, f_1 , is

$$|f_{sc} - f_1| > 2|f_r| + \frac{B_1}{2} \quad (7)$$

where f_r is the residual-carrier frequency, f_{sc} is the subcarrier frequency, and B_1 is the data-signal bandwidth, so that the down-converted signal does not mix up with the residual carrier.

To properly choose a down-mixing signal frequency, f_1 , it is also necessary to find the lowest frequency of the undesirable term(s), and choose f_1 so that the lowest frequency of the undesirable terms is higher than the highest frequency of the desired terms; so they can be filtered out or kept, respectively.

From Eq. (3) in Section II.A, it can be seen that if $f_{sc} < f_1$, the lowest undesirable frequency is $(2N+1)f_{sc} - (2N-1)f_1 - |f_r| - B_1/2$, and the highest desired frequency is $(2N-1)(f_1 - f_{sc}) + |f_r| + B_1/2$. For there to be no aliasing between the desired terms and undesirable ones, it is necessary that

$$\begin{aligned} (2N-1)(f_1 - f_{sc}) + |f_r| + \frac{B_1}{2} &< (2N+1)f_{sc} \\ &- (2N-1)f_1 - |f_r| - \frac{B_1}{2} \end{aligned} \quad (8)$$

Rearranging Inequality (8) and combining it with Inequality (7), one has

$$\begin{aligned} f_{sc} + 2|f_r| + \frac{B_1}{2} &< f_1 \\ &< \frac{2N}{2N-1}f_{sc} - \frac{1}{2N-1} \left(|f_r| + \frac{B_1}{2} \right) \end{aligned} \quad (9)$$

Similarly, if $f_{sc} > f_1$, then the lowest undesirable frequency becomes $(2N-1)f_1 - (2N-3)f_{sc} - |f_r| - B_1/2$, and the highest desired frequency, $(2N-1)(f_{sc} - f_1) + |f_r| + B_1/2$. In this case, the following is required,

$$\frac{2N-2}{2N-1}f_{sc} + \frac{1}{2N-1} \left(|f_r| + \frac{B_1}{2} \right) < f_1$$

$$< f_{sc} - 2|f_r| - \frac{B_1}{2} \quad (10)$$

As an example, let $N = 3$ and $f_1 > f_{sc}$, then Inequality (9) becomes

$$f_{sc} + 2|f_r| + \frac{B_1}{2} < f_1 < \frac{6}{5}f_{sc} - \frac{1}{5}|f_r| - \frac{1}{10}B_1 \quad (11)$$

For the signal from Galileo, $f_{sc} = 22.5$ KHz, and assuming that the data bandwidth $B_1 = 1$ KHz, $f_r = 1$ KHz, then 25 KHz $< f_1 < 26.7$ KHz.

D. Conditions on LPF Cutoff Frequency

The cutoff frequency of the LPF needs to be between the highest frequency of the desired term and the lowest frequency of the undesirable term. Assuming that an ideal LPF is used, the cutoff frequency of the LPF, f_L , should be

$$(2N-1)|f_1 - f_{sc}| + |f_r| + \frac{B_1}{2} < f_L$$

$$< \min \left\{ f_{sc} - |f_r| - \frac{B_1}{2}, f_1 - |f_r| \right\}$$

where $f_{sc} = \omega_{sc}/(2\pi)$ is the fundamental frequency of the square-wave subcarrier, $D_2(t)$, $f_1 = \omega_1/(2\pi)$ is the fundamental frequency of the mixing signal, $y(t)$, and N is the number of harmonics considered for the square wave.

Using the example of the Galileo signal again, if the cutoff frequency of the lowpass filter, $f_L < f_1 = 26$ KHz, then the condition that f_L has to be less than $7f_{sc} - 5f_1 - |f_r| - B_1/2 = 26$ KHz is satisfied, which implies that all the undesirable terms will be filtered out.

In summary, it is possible to downconvert the subcarrier to a much lower frequency, which leads to a much lower sample rate when an ideal lowpass filter is used in the absence of noise.

III. In the Presence of Noise

Assuming now that the signal is contaminated by an additive white noise, the input to the downconverter is:

$x(t) + \mathbf{n}(t)$, where $\mathbf{n}(t)$ is additive white Gaussian noise.¹ The input to the lowpass filter will be:

$$[x(t) + \mathbf{n}(t)][y(t) + 1] = x(t)y(t) + x(t) + \mathbf{n}(t)y(t) + \mathbf{n}(t)$$

The third term in the above expression needs to be expanded

$$\mathbf{n}(t)y(t) = \mathbf{n}(t)2[\cos(\omega_1 t + \Theta_1)$$

$$+ \cos 3(\omega_1 t + \Theta_1) + \cos 5(\omega_1 t + \Theta_1)]$$

where $\mathbf{n}(t)$ is a stationary additive white noise with zero mean, and autocorrelation

$$R_{nn}(t + \tau, t) = \frac{N_0}{2} \delta(\tau)$$

The product of $\mathbf{n}(t)y(t)$ results in a stochastic process with zero mean and autocorrelation [1]

$$R(t + \tau, t) = E\{\mathbf{n}(t + \tau)\mathbf{n}^*(t)y(t + \tau)y^*(t)\}$$

$$= R_{nn}(\tau)E\{y(t + \tau)y(t)\} \quad (12)$$

since $\mathbf{n}(t)$ and Θ_1 are independent. By expanding the term $y(t + \tau)y(t)$, one has

$$y(t + \tau)y(t) = 4 \{ \cos[\omega_1(t + \tau) + \Theta_1] + \cos 3[\omega_1(t + \tau) + \Theta_1]$$

$$+ \cos 5[\omega_1(t + \tau) + \Theta_1] \} [\cos(\omega_1 t + \Theta_1)$$

$$+ \cos 3(\omega_1 t + \Theta_1) + \cos 5(\omega_1 t + \Theta_1)]$$

$$= 2 \{ \cos \omega_1 \tau + \cos[\omega_1(2t + \tau) + 2\Theta_1]$$

$$+ \cos[\omega_1(-2t + \tau) - 2\Theta_1] + \cos[\omega_1(4t + \tau) + 4\Theta_1]$$

$$+ \cos[\omega_1(-4t + \tau) - 4\Theta_1] + \cos[\omega_1(6t + \tau) + 6\Theta_1]$$

$$+ \cos(\omega_1(2t + 3\tau) + 2\Theta_1) + \cos[\omega_1(4t + 3\tau) + 4\Theta_1]$$

$$+ \cos \omega_1(3\tau) + \cos[\omega_1(6t + 3\tau) + 6\Theta_1]$$

¹ All random variables and stochastic processes are boldfaced.

$$\begin{aligned}
& + \cos[\omega_1(-2t + 3\tau) - 2\Theta_1] + \cos[\omega_1(8t + 3\tau) + 8\Theta_1] \\
& + \cos[\omega_1(4t + 5\tau) + 4\Theta_1] + \cos[\omega_1(6t + 5\tau) + 6\Theta_1] \\
& + \cos[\omega_1(2t + 5\tau) + 2\Theta_1] + \cos[\omega_1(8t + 5\tau) + 8\Theta_1] \\
& + \cos \omega_1(5\tau) + \cos[\omega_1(10t + 5\tau) + 10\Theta_1]
\end{aligned}$$

By observing $y(t + \tau)y(t)$, one can see that there are two types of functions that are adding: $\cos(p\tau)$ and $\cos(qt + p\tau + q\theta_1)$, where p and q are integers that belong to the sets $\{1, 3, 5\}$ and $\{\pm 2, \pm 4, 6, 8, 10\}$, respectively. The first type of function is deterministic whose expectation is itself. To evaluate the expectation of the second type of function, one assumes that Θ_1 is a random variable with uniform distribution in $[-\pi, \pi]$. Then the expectation becomes [2].

$$\begin{aligned}
E\{\cos(qt + p\tau + q\Theta_1)\} &= \frac{1}{2\pi} \int_{-\pi}^{\pi} \cos(qt + p\tau + q\Theta_1) d\Theta_1 \\
&= \frac{1}{2\pi q} [\sin(qt + p\tau + q\pi) \\
&\quad - \sin(qt + p\tau - q\pi)] \\
&= 0
\end{aligned}$$

since q is an even number. So the autocorrelation function of the process $\mathbf{n}(t)y(t)$ becomes

$$R(\tau) = N_0 \delta(\tau) [\cos(\omega_1 \tau) + \cos(3\omega_1 \tau) + \cos(5\omega_1 \tau)]$$

The power spectrum of the process $\mathbf{n}(t)y(t)$, $S(\omega)$, is the Fourier transform of the autocorrelation function, $R(\tau)$ [2],

$$S(\omega) = \mathcal{F}\{R(\tau)\} = 3N_0 \quad (13)$$

This implies that the noise level will be increased by about 7.8 dB/Hz after the downconversion, which is not acceptable. One solution to this problem is to put $N + 1$ bandpass filters before the downconversion, in order to select only the residual carrier and the subcarrier harmonics, as illustrated in Fig. 3.

If three harmonics are considered for the subcarrier, then four ideal bandpass filters connected in parallel are

needed. The first one is used to keep the residual carrier, with its center frequency at $|f_r|$. The other three filters are used for the three harmonics of the square-wave subcarrier and the data signal around them. Their center frequencies should be the appropriate harmonics of the subcarrier [see Fig. 1(a)]. The bandwidth of these harmonic filters, f_B , should be as narrow as possible with the condition $f_B \geq B_1 + 2|f_r|$ so that the data signal is allowed to pass. However if the bandwidth of the BPF is too narrow, there will be colored noise after the downconversion. To obtain the so-called white noise² after the downconversion, the BPF bandwidth should be $f_B = (f_L - |f_r|)N$.

Note that the above analysis ignores the noise power of the output of the bandpass filter for the residual carrier since its bandwidth is much smaller than that of the data signal.

IV. Boundaries on Downconversion

The selection of the downconversion circuit and associated filters must consider the following boundaries to ensure no aliasing of spectra. Assuming that all the filters are ideal, the conditions are summarized as follows.

The cutoff frequency of the lowpass filter has to be

$$\begin{aligned}
(2N - 1)|f_1 - f_{sc}| + |f_r| + \frac{B_1}{2} &< f_L \\
&< \min \left\{ f_1 - |f_r|, f_{sc} - |f_r| - \frac{B_1}{2} \right\}
\end{aligned}$$

The lower bound is to keep the $2N - 1$ th harmonic of the square wave plus the data around it, and the upper bound is to eliminate all the other undesirable terms.

The bandwidth of the bandpass filters has to be

$$f_B \geq B_1 + 2|f_r|$$

and

$$f_B = \frac{f_L - |f_r|}{N}$$

to keep the noise level as low as if no downconversion is ever done.

² Flat average power spectrum within the considered band.

The mixing signal can be

$$\begin{aligned}
 y(t) + 1 &= 2 \operatorname{sgn}(\omega_{sc} - \omega_1) \{ \cos(\omega_1 t) \\
 &+ \cos(3\omega_1 t) + \cos(5\omega_1 t) \\
 &+ \cdots + \cos[(2N - 1)\omega_1 t] \} + 1
 \end{aligned}$$

The fundamental frequency of $y(t)$ has to be either

$$\begin{aligned}
 f_{sc} + 2|f_r| + \frac{B_1}{2} &< f_1 \\
 &< \frac{2N}{2N-1} f_{sc} - \frac{1}{2N-1} \left(|f_r| + \frac{B_1}{2} \right) \quad (14)
 \end{aligned}$$

or

$$\begin{aligned}
 \frac{2N-2}{2N-1} f_{sc} + \frac{1}{2N-1} \left(|f_r| + \frac{B_1}{2} \right) &< f_1 \\
 &< f_{sc} - 2|f_r| - \frac{B_1}{2} \quad (15)
 \end{aligned}$$

The lower bound in Inequality (14), the upper bound in Inequality (15), is for the downconverted signal not to overlap with the residual carrier and between the harmonics, and the upper bound in Inequality (14), the lower bound in Inequality (15), is for the LPF to be able to filter out the undesirable terms.

As a conclusion, the single-sided bandwidth of the down converted signal, $BW/2$, is

$$\frac{BW}{2} = (2N - 1)|f_{sc} - f_1| + |f_r| + \frac{B_1}{2}$$

and Figs. 4 and 5 illustrate this bandwidth with B_1 and f_r as variables.

V. Conclusions

This article discussed the possibility of downconverting the square-wave subcarrier of signals such as those sent from Galileo. A practical method is given to compress the bandwidth of the square-wave subcarrier by using a finite number of harmonics, where most of the received signal power is located.

References

- [1] A. Papoulis, *Signal Analysis*, New York: McGraw-Hill, p. 300, 1977.
- [2] A. Papoulis, *Probability, Random Variables, and Stochastic Processes*, New York: McGraw-Hill, pp. 142 and 338, 1965.

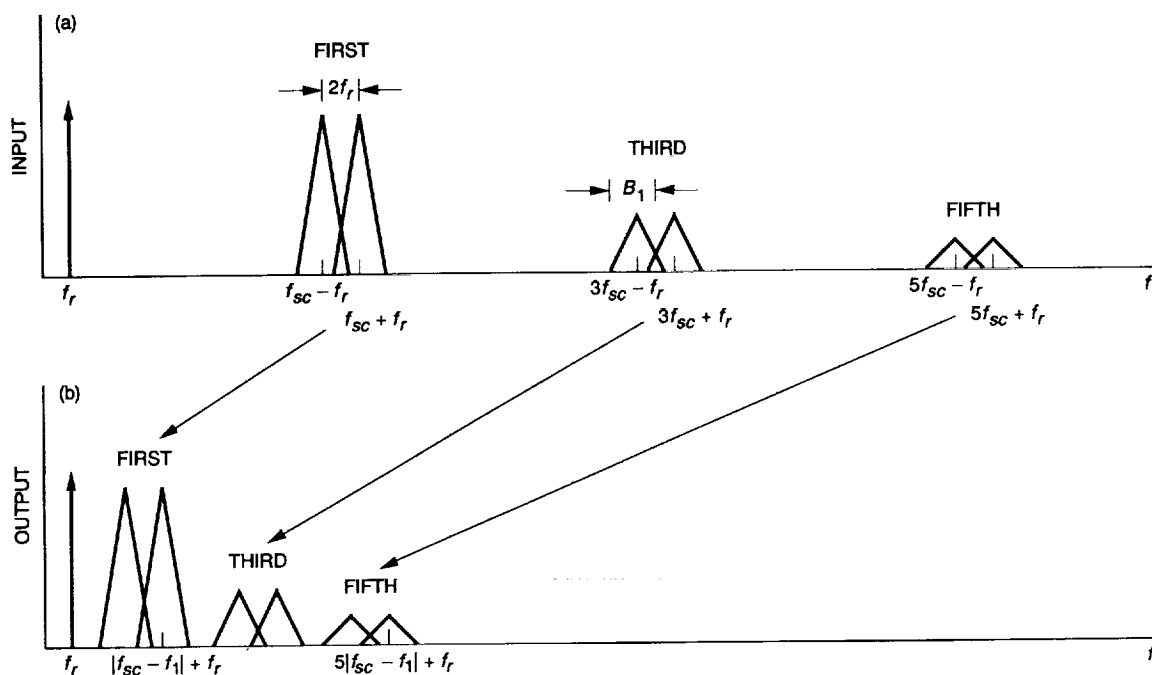

Fig. 1. Bandwidth compression shown in the frequency domain: (a) Spectrum before downconversion and (b) Spectrum after downconversion.

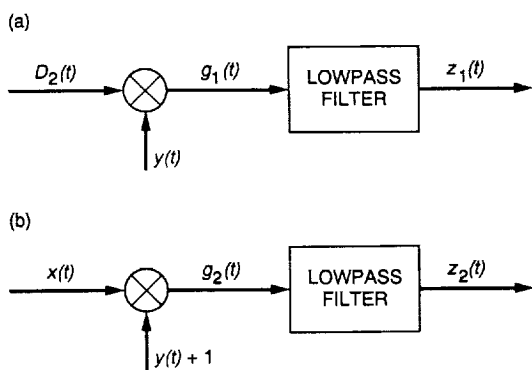

Fig. 2. The downconversion in the absence of noise: (a) Square-wave subcarrier only and (b) Residual carrier and data present.

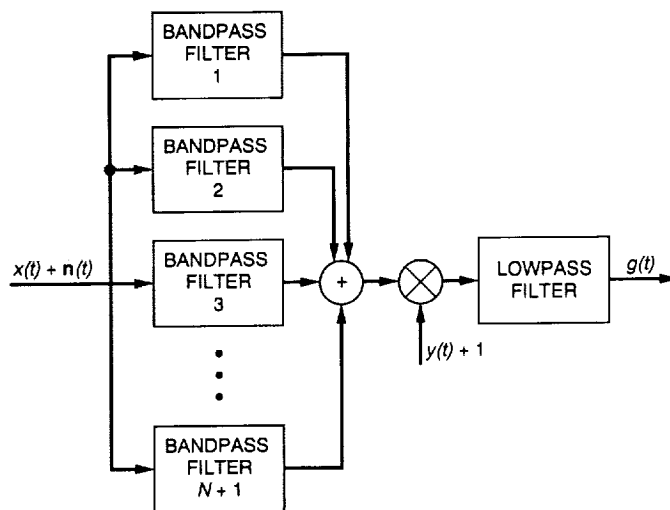

Fig. 3. The downconverter in the presence of noise.

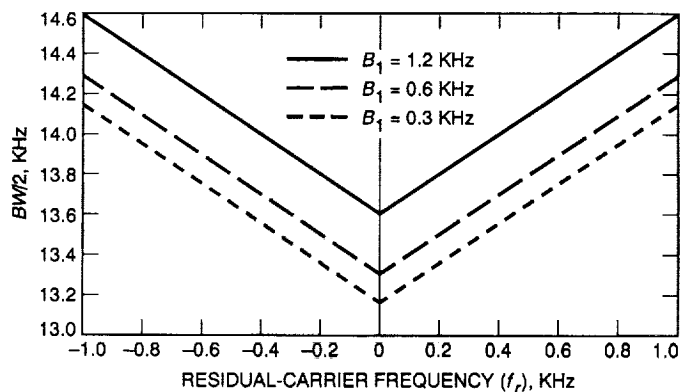

Fig. 4. The single-sided bandwidth of the downconverted signal. Assumptions: (a) Ideal lowpass filter and bandpass filter and (b) Constant f_1 , $|f_{sc} - f_1| = 2.6$ KHz.

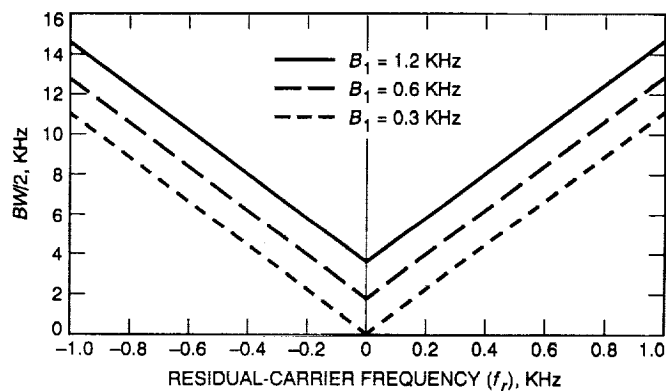

Fig. 5. The minimal single-sided bandwidth of the downconverted signal. Assumption: Ideal lowpass filter and bandpass filter.