

# A HYDROGEN MASER WITH CAVITY AUTO-TUNER FOR TIMEKEEPING

177  
P-8  
N 9 2 - 3 3 3 6 4

C. F. Lin, J. W. He, and Z. C. Zhai  
Shanghai Observatory  
Academia Sinica

## Abstract

*A hydrogen maser frequency standard for timekeeping has been worked at Shanghai Observatory. The maser employs a fast cavity auto-tuner, which can detect and compensate the frequency drift of the high-Q resonant cavity with a short time constant by means of a signal injection method, so the long term frequency stability of the maser standard was greatly improved. This paper describes the cavity auto-tuning system and some maser data obtained from the atomic time comparison.*

## INTRODUCTION

Shanghai Observatory has very strict requirements for precise frequency and time. These requirements arise from the need of atomic time scale keeping as well as a variety of radio astronomical experiments such as VLBI. At the present time, the hydrogen maser standards developed by Shanghai Observatory have been used for timekeeping and VLBI stations in China. The frequency stability of the standards is to parts in  $10^{-15}$  at 1,000 seconds averaging period of time, but this stability degrades at longer averaging intervals due to the influences of environment and cavity aging. This long term stability leads to time and frequency errors which requires frequency correction to maintain clock accuracy.

To greatly reduce the requirement for frequency adjustment and tuning to compensate for long term cavity drift and/or environmental changes, a continuous cavity auto-tuner for the hydrogen maser was developed at Shanghai Observatory with good success. The auto-tuner has been installed in a hydrogen maser and proved a successful method which can provide such continuous tuning without much perturbing the maser short term stability.

## GENERAL DESCRIPTION

The hydrogen maser frequency standard with the auto-tuner is an active oscillator. Fig. 1 is a picture of the maser and Fig. 2 is a line drawing illustrating the maser structure. One of the unique and important features of the maser is the incorporation of a cavity auto-tuner to maintain the cavity at a constant frequency relative to the hydrogen

emission line. The auto-tuner is a stand-alone system and does not require periodic source pressure changes or a separate frequency reference as used in the traditional spin-exchange method of cavity tuning. Besides, the present design of all the maser standard paid more attention to the compact configuration, so that the maser has a rugged, reliable and transportable feature [1], [2].

## CAVITY AUTO-TUNER

The principle of the cavity auto-tuner is described in Fig. 3 [3], [4]. when a frequency modulated microwave signal  $f(t)$  is transmitted through the cavity, an amplitude response signal  $A(t)$  is obtained in the output signal, then applied to varactor coupled to the microwave cavity by a lock-in amplifier, so that the cavity resonant frequency response is maintained to the desired solid curve throughout. A schematic diagram of the cavity auto-tuner for the maser is shown in Fig. 4.

### 1. 11Hz Squarewave Generator

The block diagram of the generator is shown in Fig. 5. The generator has two outputs. The one is applied to the  $20.405 \pm f_m$  MHz switched synthesizer to modulate the frequency, the other one is applied to a synchronous detector circuit where an "up" or "down" error signal is generated. The phase shifter is adjusted to ensure that the cavity auto-tuner is a negative feedback system.

### 2. $20.405 \pm f_m$ MHz switched synthesizer

As we knew, the  $20.405 \pm f_m$  MHz signal which is mixed with 1.400 MHz signal generates a  $1,420.405 \pm f_m$  MHz frequency modulated signal. To prevent interference with the maser operation, the nearly complete carrier suppression in the injected microwave signal must be required. At the same time, the power of the injected signal in  $1,420.405 + f_m$  MHz, and one of the signal in  $1,420.405 - f_m$  MHz must be equal, where  $f_m = 0.015$  MHz. Fig. 6 is the block diagram of the  $20.405 \pm f_m$  MHz switched synthesizer, where using PLL is to improve the frequency spectrum of the output signal. Fig. 7 (a) and (b) are the pictures of  $20.405 \pm f_m$  MHz and  $1,420.405 \pm f_m$  MHz signals, which are measured by HP8566A frequency spectrum analyzer.

### 3. Lock-in Amplifier

The lock-in amplifier is described in Fig. 8. The amplitude response signal is amplified, rectified and sent to a synchronous detector, and then an "up" or "down" signal is given.

After filtered and integrated, the signal by a bias is added to the varactor in the cavity.

#### 4. Phase-locked receiver

Some improvements were made in the phase-locked receiver. First, a narrow crystal filter (BW=2KHz), which suppresses the injected signal, is inserted to prevent it from interfering the phase-locked loop operation. However, all circuits before the crystal filter must have a wide operating frequency band to transmit the injected signal to lock-in amplifier without phase and amplitude loss. Second, the 405KHz digital synthesizer adopted a new digit direct-dividing and combining technique and avoided the adjusting complexity of the phase-locked loop combination.

## TEST RESULTS

The first series of tests were made to determine the operating characteristics of the maser with and without the auto-tuner. Allan variance data plots, turning on and off the cavity auto-tuner, are contained Fig. 9, and clearly show that there is only minimal degradation of the maser short term stability with the introduction of the injected signal of the cavity auto-tuner. However, the long term stability of the maser has greatly been improved.

These tests have been made under normal working laboratory conditions in an area where the temperature is held to approximately  $23^{\circ}\text{C} \pm 1^{\circ}\text{C}$ . The reference maser is  $\text{H}_7$  (1), (2).

In addition, the maser has been working continuously for atomic timekeeping at Shanghai Observatory since June, 1991. Fig. 10 shows the comparison data measured between the maser clock and UTC by means of GPS receiver. The data illustrates the maser frequency standards with cavity auto-tuner can be used for time keeping.

Much more stability data will be taken under different condition of operation and for longer times. The maser is still being tested and adjusted to optimize the maser parameters, however, the present data is quite encouraging.

## ACKNOWLEDGEMENTS

We are very much obliged to thank Dr. Nakagiri and Dr. Onta at CRL, Japan for offering the first author the opportunity to work in CRL. We also gratefully wish to thank our colleagues for supporting this work.

## REFERENCES

- (1) . Z.C.Zhai, etc, Proc. of 41st annual symposium on Frequency Control, 1987
- (2) . Z.C.Zhai, etc, Proc. of international symposium on Electromagnetic Metrology, 1989
- (3) . C. Audion, Rev. Phys. Appl., 16 (1981)
- (4) . C.F.Lin, etc. Journal of CRL, Japan, No., 1989
- (5) . J.W.He, etc. Annals of Shanghai Observatory, Academia Sinica, 1990

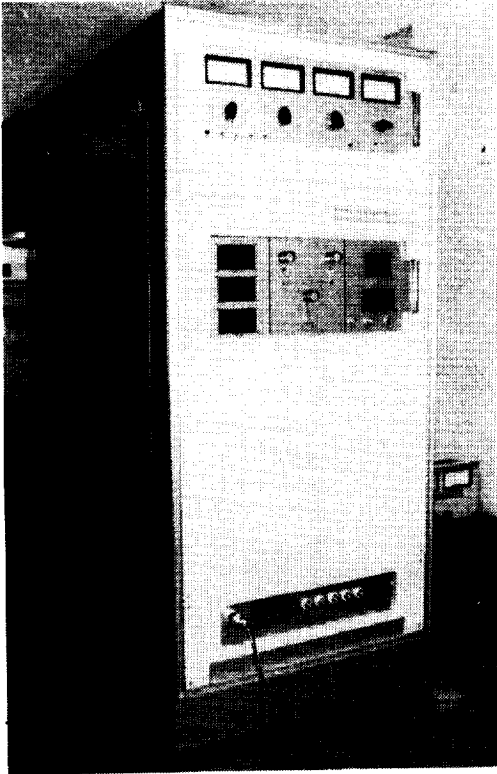

Fig. 1. The Hydrogen Maser with Auto-Tuner for Time Keeping

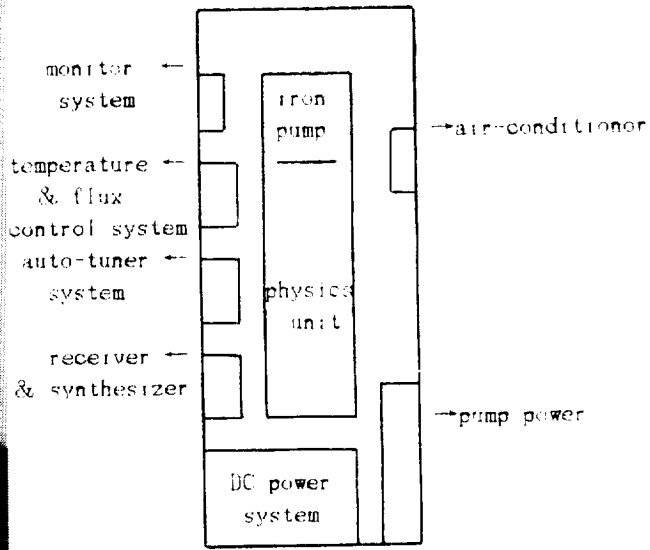

Fig. 2. The Maser Structure

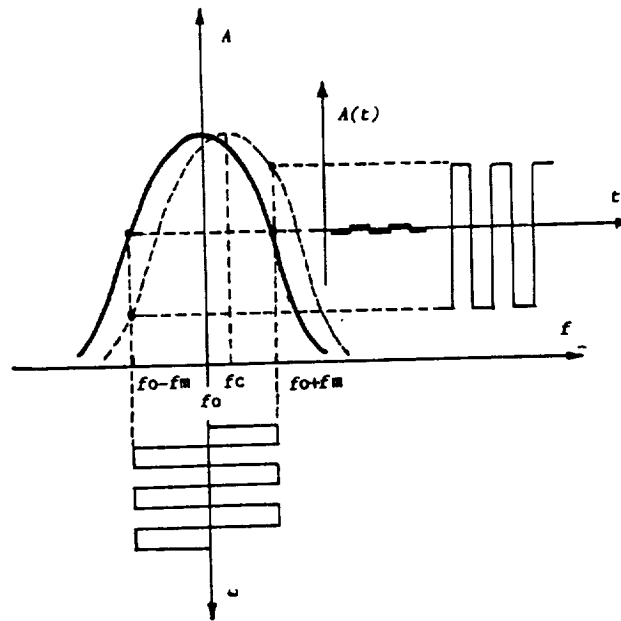

Fig. 3. Response of Cavity to Frequency Modulated Signal

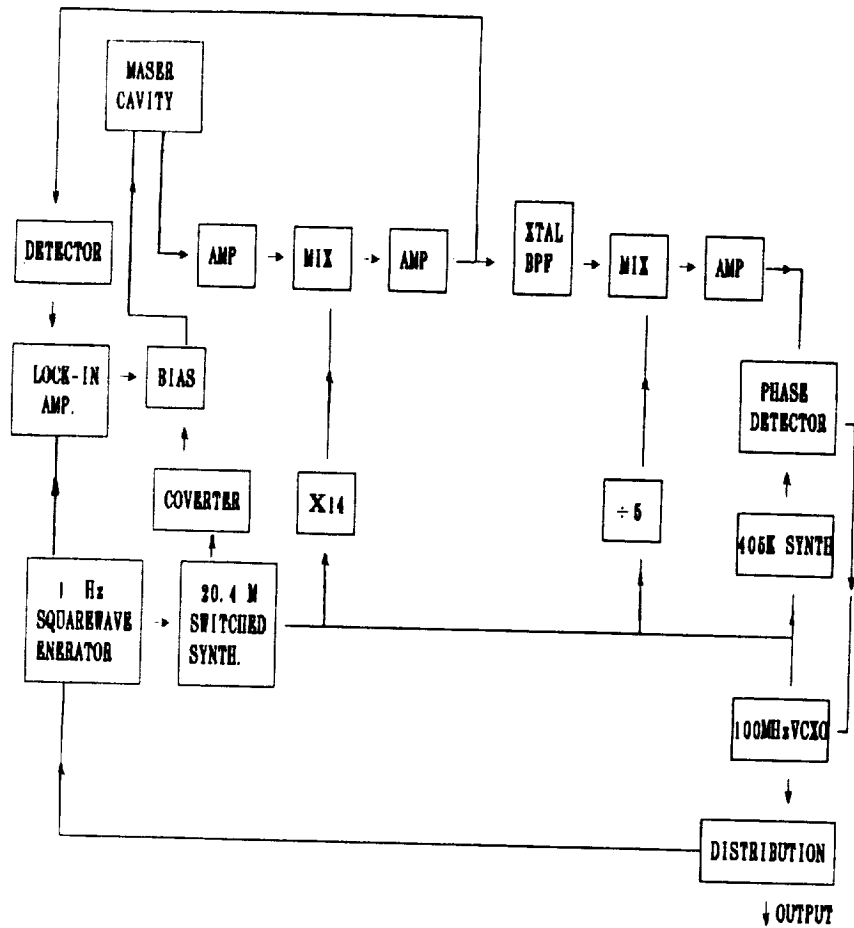

Fig. 4. Cavity Auto-Tuner System

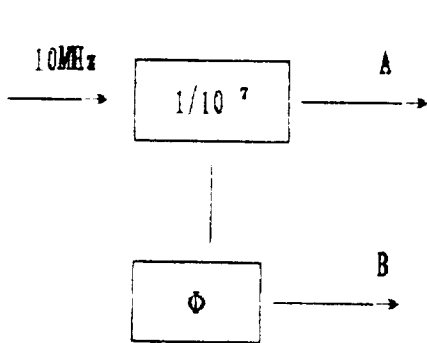

Fig. 5. 1 Hz Squarewave Generator

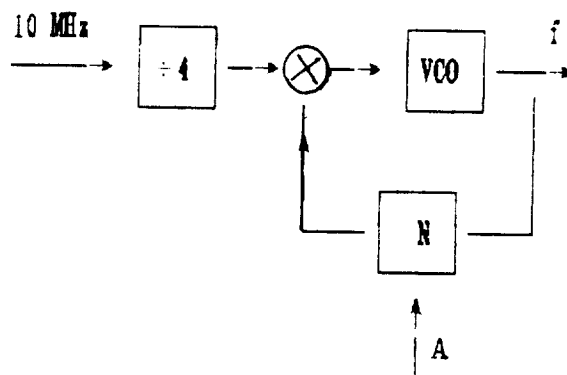
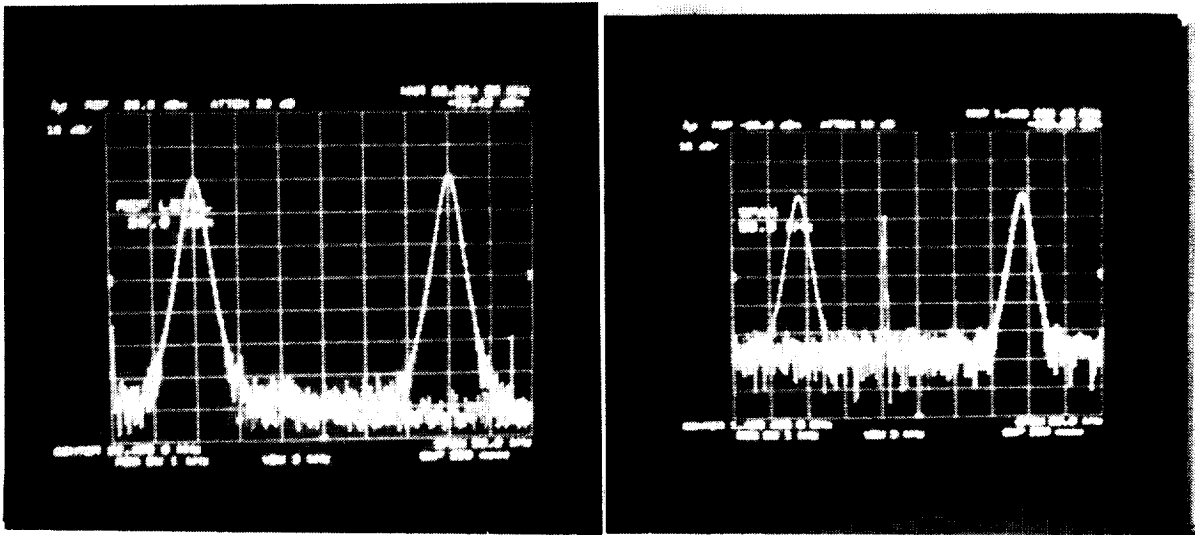

Fig. 6.  $20.405 \pm f$  MHz Switched Synthesizer



(a)

(b)

Fig. 7. Frequency Spectrum of  $20.405 \pm f_m$  MHz and  $1,420.405 \pm f_m$  MHz signals

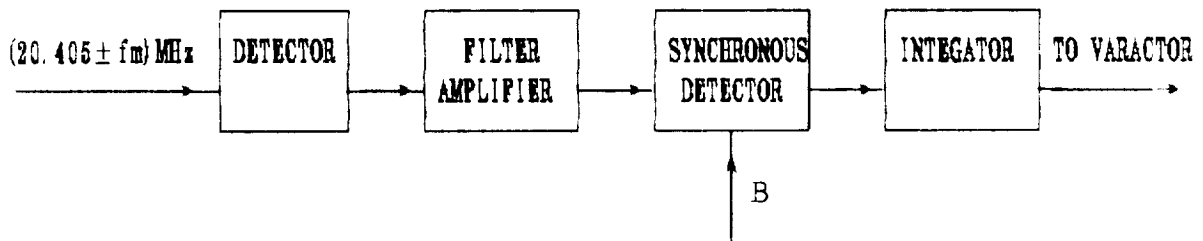

Fig. 8. Lock-in Amplifier

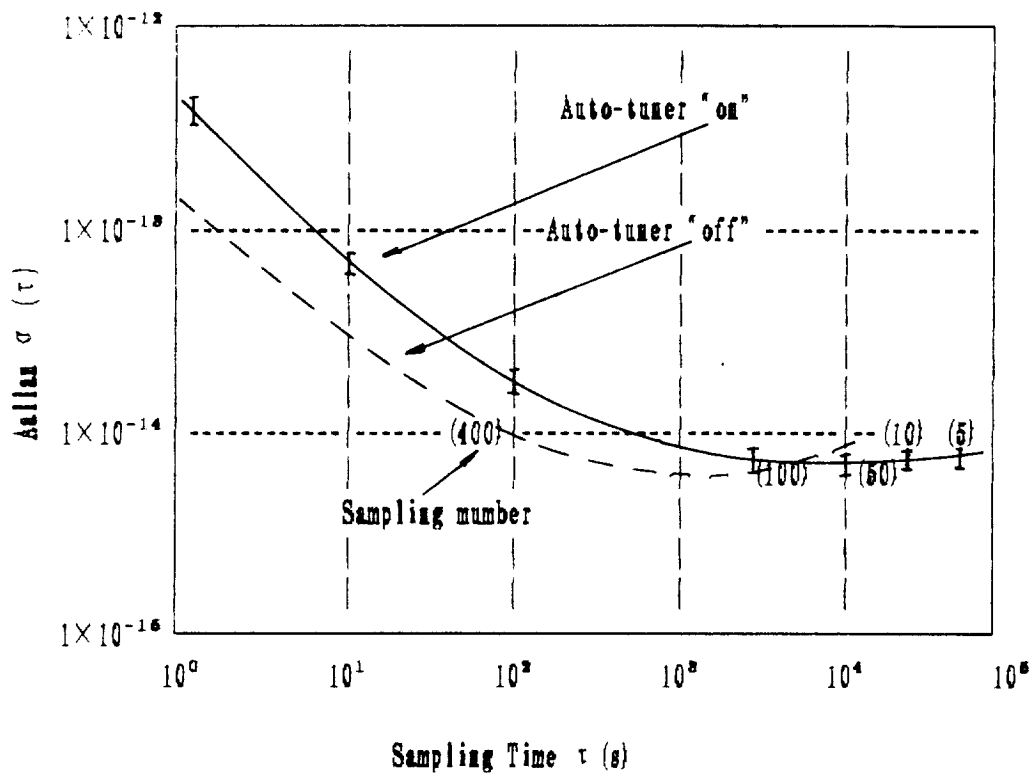

Fig. 9. Allan variance

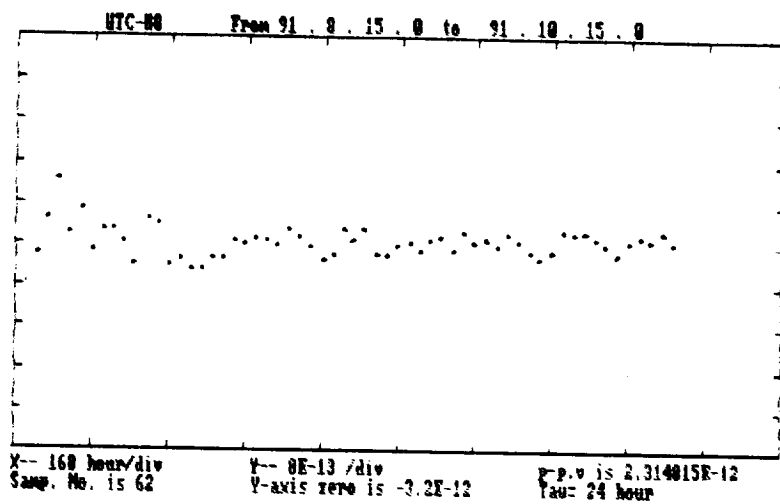

Fig. 10. Maser Clock and UTC compared data