

AWT DRIVE SYSTEM DISCUSSION

LONNIE REID

HEAD, MULTISTAGE COMPRESSOR SECTION

NASA LEWIS RESEARCH CENTER

*NP 92-493*

N 9 2 - 4 9 3

*7/1/80*

*510-07*

388

DRIVE SYSTEM TASK TEAM  
LEADER L. REID

OBJECTIVE: DEVELOP A PHYSICAL MODEL OF THE AWT FAN DRIVE THAT WILL  
PRODUCE THE DESIRED PERFORMANCE IN THE AWT ENVIRONMENT

APPROACH:

- 0 SELECT KEY PERSONNEL
- 0 IDENTIFY CRITICAL ASPECTS OF PROBLEM
- 0 ANALYTICAL MODELING
- 0 PHYSICAL MODELING

DRIVE SYSTEM TASK TEAM MEMBERS  
LEADER L. REID

SANDERCOCK, D. M.	CONSULTANT	(2420)
SCHMIDT, J. F.	FAN AERO. DESIGN	(2421)
STEINKE, R. J.	FAN AERO. DESIGN	(2423)
STEVANS, W.	MECH. DESIGN AND OPERATIONS	(2452)
URASEK, D. C.	MECH. DESIGN AND OPERATIONS	(2423)
BOLDMAN, D. R.	DIFFUSER/TURNING VANES PERFORMANCE ASSESSMENT AND TASK TEAM LIAISON PERSON	(2423)
MOORE, R. D.	FAN AND PERFORMANCE	(2422)
HATHAWAY, M.D.	FUNDAMENTAL RESEARCH PROGRAM	(0300)

## DRIVE SYSTEM

### CRITICAL ASPECTS:

- O MUST QUANTIFY FAN INLET FLOW FIELD
- O MODELING EFFORTS TO ASSESS FAN INLET FLOW CONDITIONS AND TURNING VANES PERFORMANCE MUST BE CLOSELY INTEGRATED
- O MUST ANALYZE FAN DESIGN WITH APPROPRIATE FLOW PATH GEOMETRY

## DRIVE SYSTEM

### PHYSICAL MODELING: 0.10 SCALE

- O MODEL FLOW PATH WITH ELBOW, TURNING VANES, SHAFT AND CENTER-BODY TO ASSESS FAN INLET CONDITIONS
- O TEST MODEL FAN WITH CLEAN INLET FLOW TO ASSESS DESIGN PERFORMANCE
- O TEST MODEL FAN WITH UPSTREAM ELBOW AND TURNING VANES
- O CANDIDATE FACILITIES -
  - W1 - FOR ELBOW, TURNING VANES AND CENTER-BODY MODEL
  - W2 - FOR FAN MODEL TESTING

## 2.2 DRIVE SYSTEM

### 2.2.1 ANALYTICAL MODELING

2.2.1.1 BASELINE (PER) DESIGN

2.2.1.2 ALTERNATE DESIGNS

### 2.2.2 AERODYNAMIC DESIGN OF BLADE AND VANE AIRFOILS

2.2.2.1 TURNING VANES (CORNER 2)

2.2.2.2 ROTOR BLADES

2.2.2.3 IGV, STATORS AND OGV

### 2.2.3 MECHANICAL DESIGN AND FABRICATION

2.2.3.1 BLADE ROWS

2.2.3.2 ROTATING HARDWARE

2.2.3.3 CASING HARDWARE

2.2.3.4 SIGHT PREPARATION

### 2.2.4 PHYSICAL MODELING

2.2.4.1 FAN FLOWPATH WITH TV, IGV AND CENTERBODY

2.2.4.2 FAN WITH BELLMOUTH INLET AND LS-TEST SECTION

2.2.4.3 FAN WITH CORNER #2, & LS-TEST SECTION

2.2.4.4 FAN WITH CORNERS #1 AND 2 AND LS-TEST SECTION

# AWT FLOW CIRCUIT

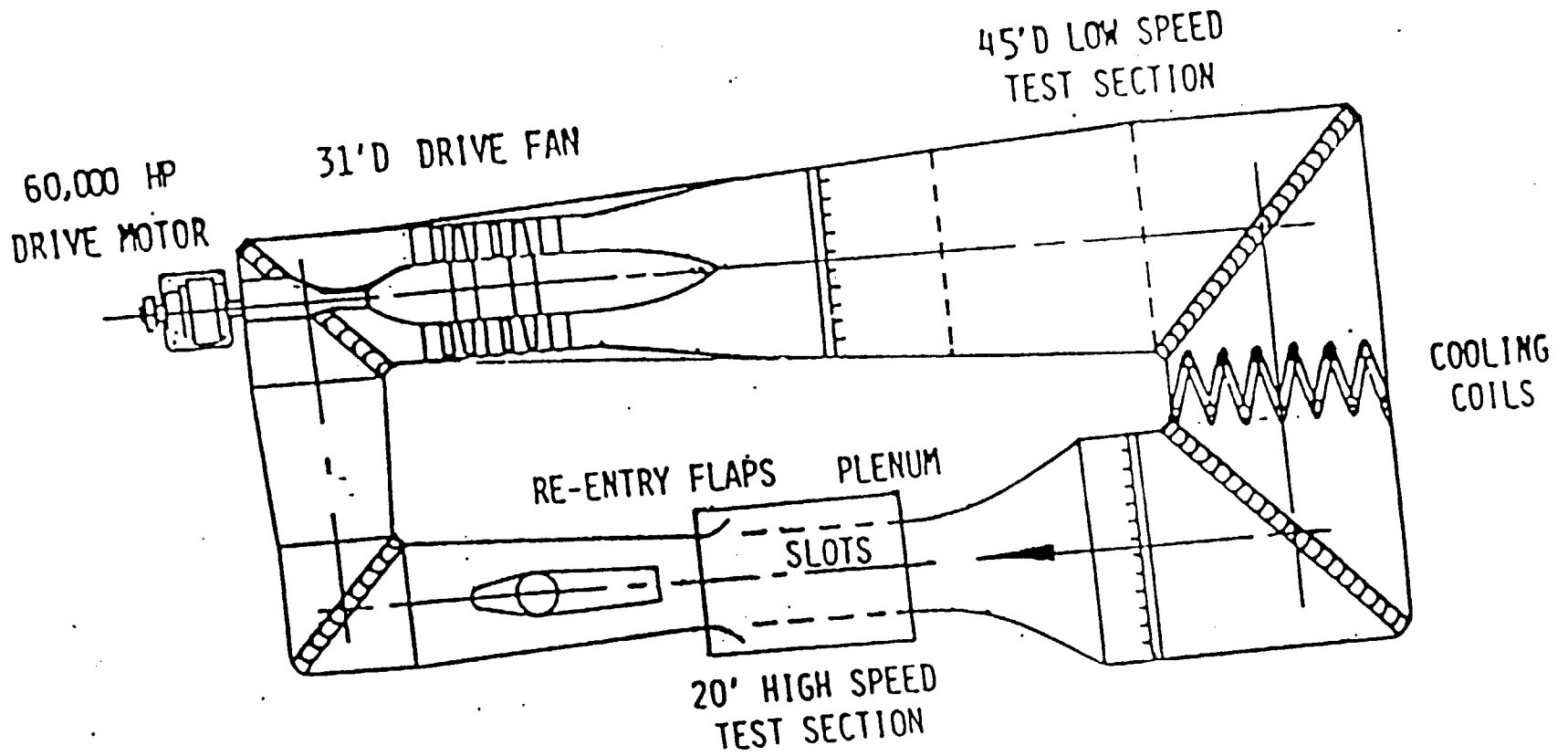

FAN FLOWPATH WITH #2 CORNER-TV, IGV & CENTERBODY

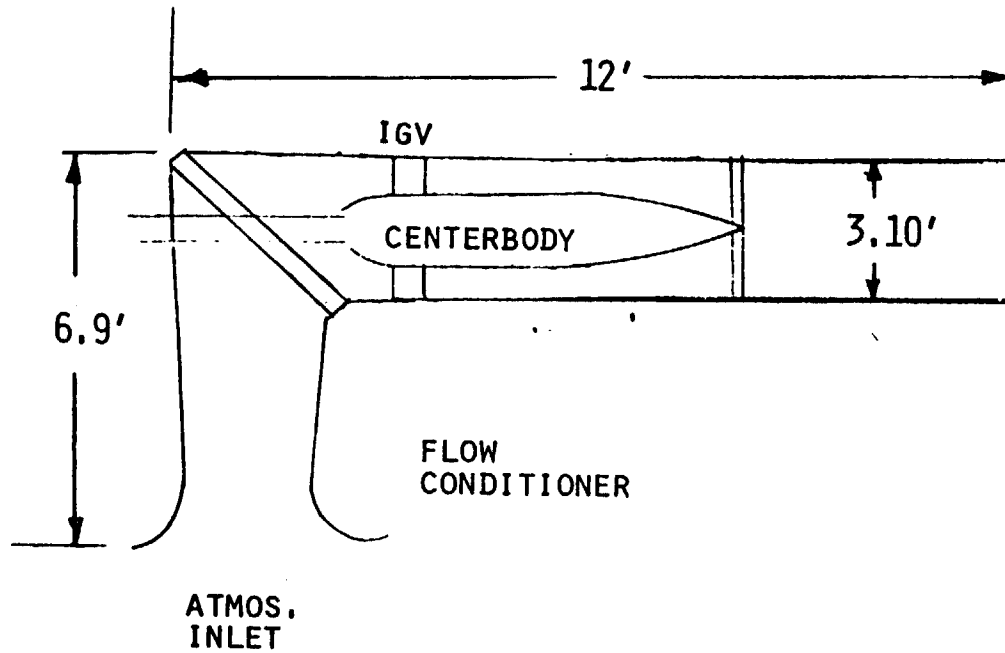

ALTITUDE EXHAUST

FLOW: 155 LBM/SEC

MEASUREMENTS:

TOTAL PRES.	- - -	68
STATIC PRES.	- -	260
FLOW ANGLES	- - -	14
TOTAL TEMP.	- - -	2



# FAN FLOWPATH WITH CORNERS #1, 2-TV, IGV & CENTERBODY

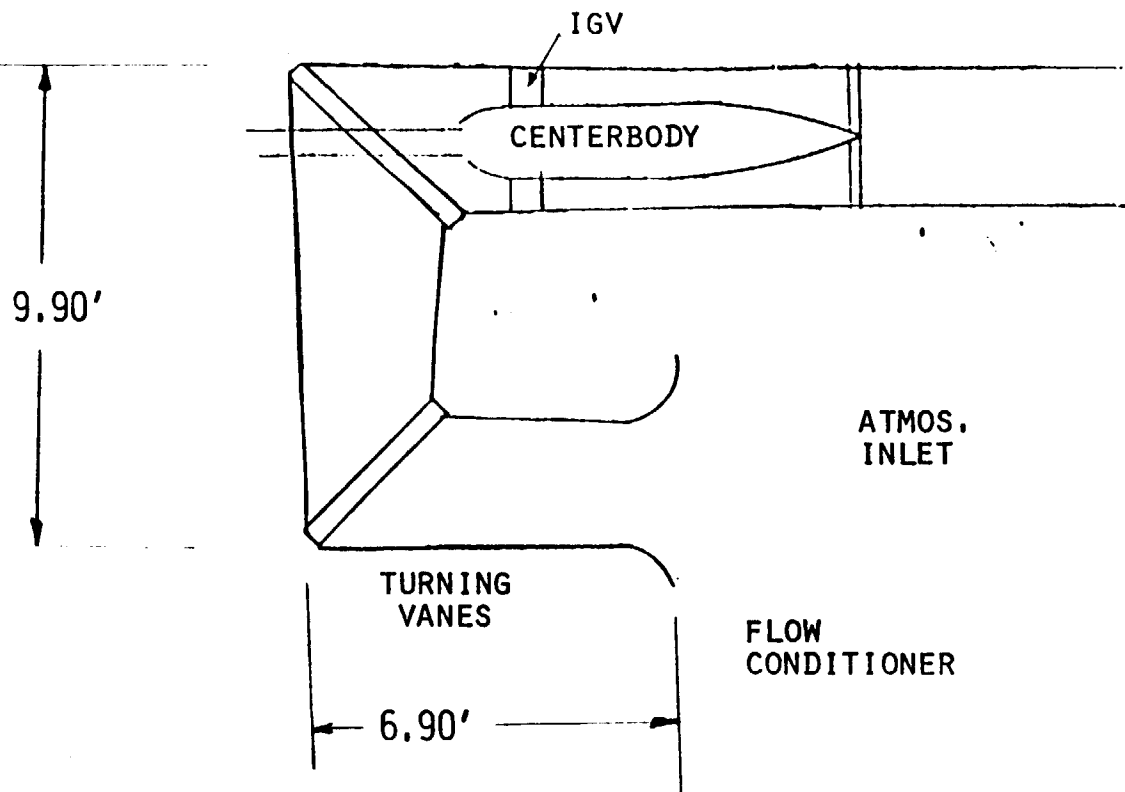

## MEASUREMENTS:

TOTAL PRES.	- -	75
STATIC PRES.	- -	300
FLOW ANGLES	- -	20
TOTAL TEMP.	-	2

# FAN WITH BELLMOUTH AND LOW SPEED TEST SECTION

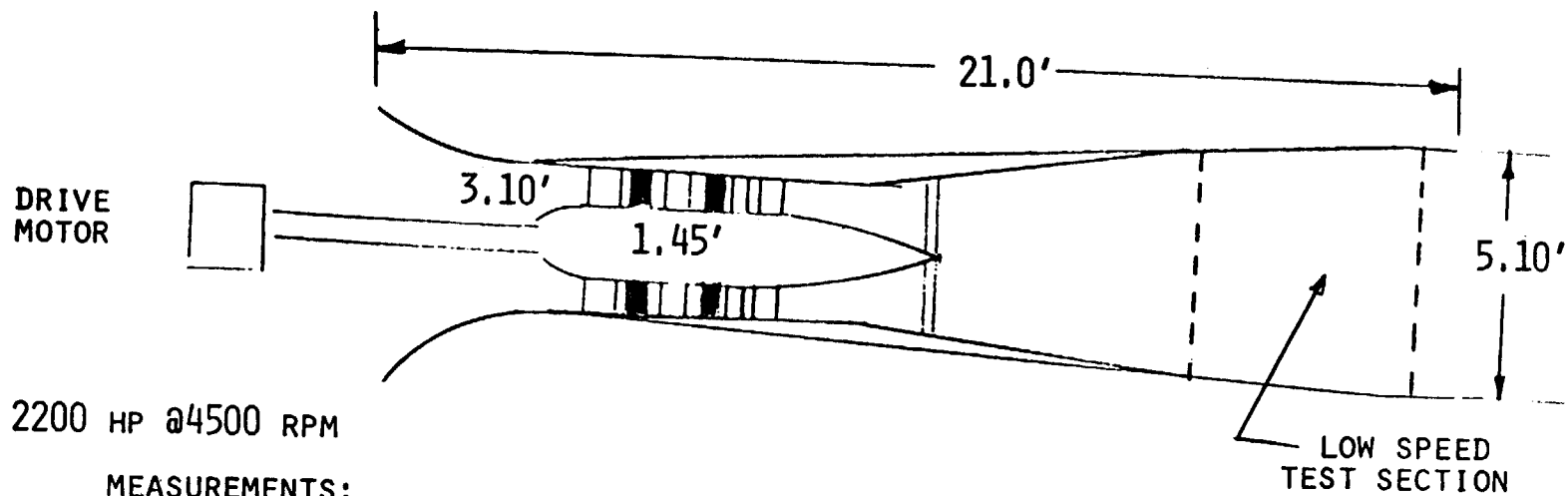

2200 HP @4500 RPM

## MEASUREMENTS:

TOTAL PRES.	- -	32
STATIC PRES.	- -	32
WALL STATIC TAPS	- -	100
TOTAL TEMP	- - - -	32
FLOW ANGLES	- - - -	32

FAN WITH #2 CORNER-TV AND LOW SPEED TEST SECTION

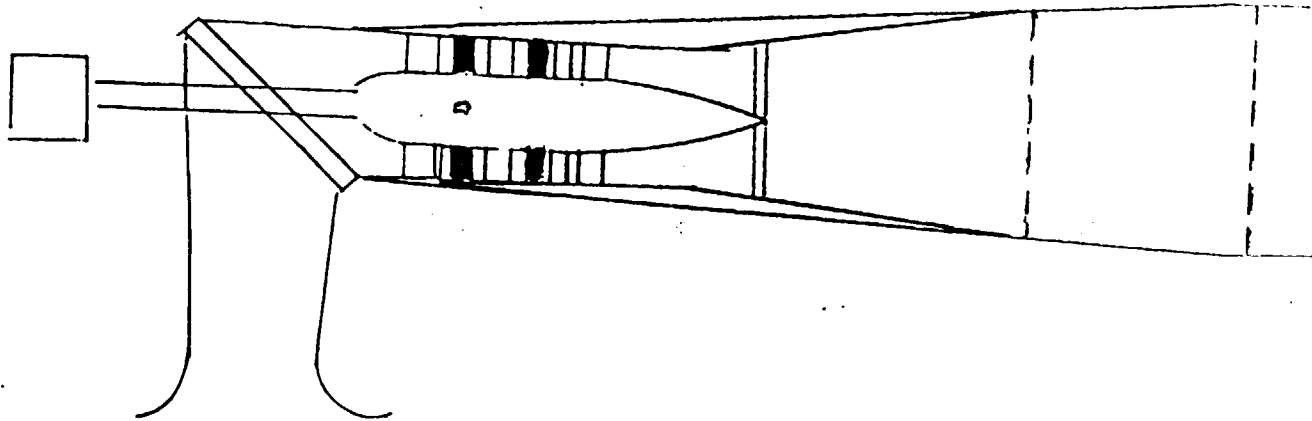

FAN WITH CORNERS #1,2-TV, & LOW SPEED TEST SECTION

