

**INTEGRATION AND USE OF A MICROGRAVITY RESEARCH  
FACILITY: LESSONS LEARNED BY THE CRYSTALS BY VAPOR  
TRANSPORT EXPERIMENT AND SPACE EXPERIMENTS  
FACILITY PROGRAMS**

Presented by Barbara L. Heizer  
Boeing Defense and Space Group

**ABSTRACT**

The Crystals by Vapor Transport Experiment (CVTE) and Space Experiments Facility (SEF) are materials processing facilities designed and built for use on the Space Shuttle middeck. The CVTE was built as a commercial facility owned by the Boeing Company. The SEF was built under contract to the UAH Center for Commercial Development of Space (CCDS). Both facilities include up to three furnaces capable of reaching 850°C minimum, stand-alone electronics and software, and independent cooling control. In addition, the CVTE includes a dedicated stowage locker for cameras, a laptop computer, and other ancillary equipment. Both systems are designed to fly in a Middeck Accommodations Rack (MAR), though the SEF is currently being integrated into a Spacehab rack. The CVTE hardware includes two transparent furnaces capable of achieving temperatures in the 850° to 870° C range. The transparent feature allows scientists/astronauts to directly observe and affect crystal growth both on the ground and in space. Cameras mounted to the rack provide photodocumentation of the crystal growth. The basic design of the furnace allows for modification to accommodate techniques other than vapor crystal growth.

Early in the CVTE program, the decision was made to assign a principal scientist to develop the experiment plan, affect the hardware/software design, run the ground and flight research effort, and interface with the scientific community. The principal scientist is responsible to the program manager and is a critical member of the engineering development team. As a result of this decision, the hardware/experiment requirements were established in such a way as to balance the engineering and science demands on the equipment. Program schedules for hardware development, experiment definition and material selection, flight operations development and crew training, both ground support and astronauts, were all planned and carried out with the understanding that the success of the program science was as important as the hardware functionality.

The CVTE payload has been delivered to the Kennedy Space Center and is undergoing final assembly and check-out prior to installation on the orbiter Columbia. It is manifested to fly on STS-S2. The SEF is undergoing assembly and checkout prior to environmental testing at the Boeing facility in Kent, WA. It will be delivered to the UAH in early October, 1992.

This presentation will be a discussion of how the CVTE payload was designed and what it is capable of, the philosophy of including the scientists in design and operations decisions, and the lessons learned during the integration process.



---

---

**Integration and Use of a Microgravity  
Research Facility: Lessons Learned by the  
CVTE and SEF Programs**

Barbara Helzer  
August 5, 1992

---

---

***BOEING***

**Crystals by Vapor Transport Experiment  
Outline**

***BOEING***

**Program Overview**

**Hardware Status**

**System Requirements**

**Integration Issues: Lessons Learned**

**Summary**

7/20/92

## Crystals by Vapor Transport Experiment Program Overview

**BOEING**

### Objectives:

Design, fabricate and assemble a microgravity materials processing facility for use on the Space Shuttle Middeck.

Develop the procedures, staff, experience, and facilities required to integrate complex payloads into a manned space system.

Develop a flexible, user friendly furnace facility capable of providing a stable, programmable thermal environment up to 850° C

August 5, 1992 2

## Crystals by Vapor Transport Experiment Program Overview

**BOEING**

### Approach:

Develop cooperative agreements with premier scientists and crystal growers

Select vapor transport crystal growth process

Identify candidate materials for space processing demonstration

Commercially viable

Potential for improved quality

Growth time: 8 min < GT < 2 days

August 5, 1992 3

## Crystals by Vapor Transport Experiment Program Overview

**BOEING**

### Approach (cont.):

Execute a Joint Endeavor Agreement (JEA) with NASA for microgravity experiments on shuttle flights

Design, develop, and fly hardware to perform these experiments

Expand capabilities to include advanced applications

August 5, 1992 - 4

## Crystals by Vapor Transport Experiment Program Overview

**BOEING**

### Technology Application:

Space Systems are a major Boeing product area

Materials processing in space is a prime element of space commercialization

Potential markets exist for space materials processing facilities

Supports Space Station operation and growth

August 5, 1992 - 5

# Crystals by Vapor Transport Experiment Program Overview

**BOEING**

## CVTE: Crystals by Vapor Transport Experiment

2-furnace facility with independent electronics and S/W  
Transparent furnaces, 2 samples/furnace  
Middeck payload

## SEF: Space Experiments Facility

2nd CVTE facility being built for the UAH  
3-furnace facility; 2 transparent/1 opaque (1050 °C)  
Middeck payload

August 5, 1992 5

SD2-4243-R0

# Crystals by Vapor Transport Experiment Make, Buy, and GFE Hardware

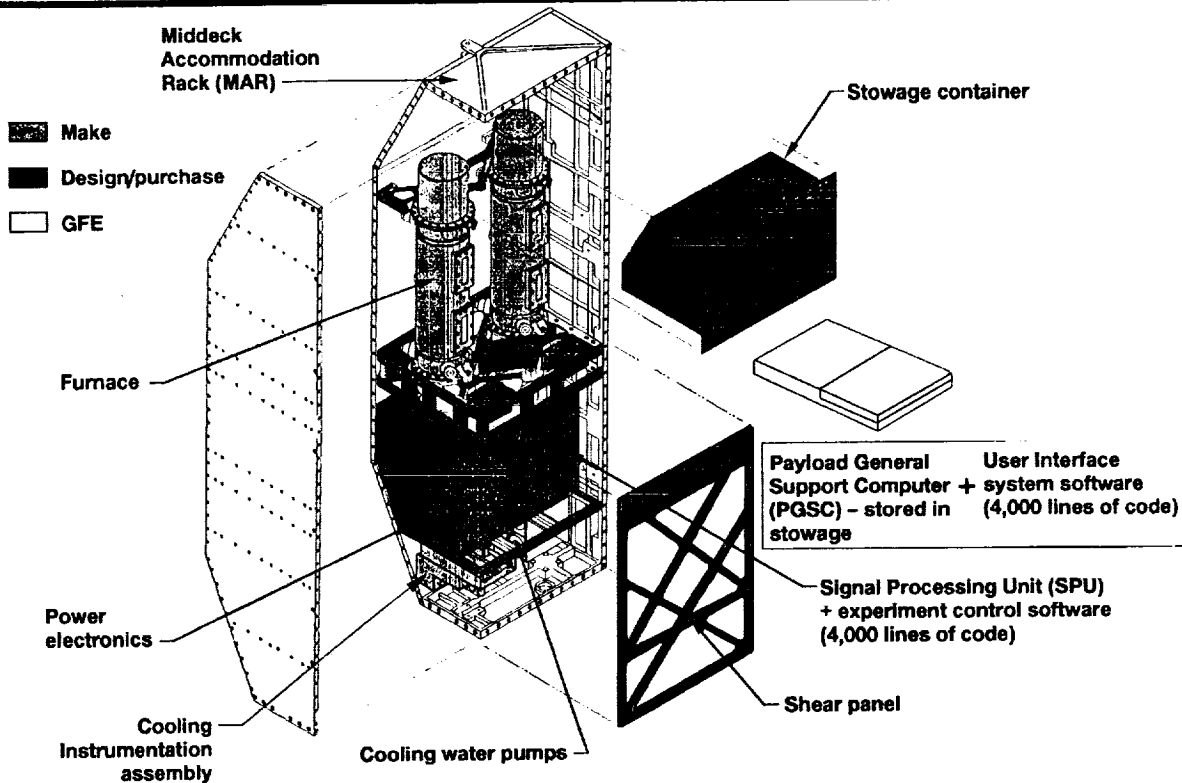



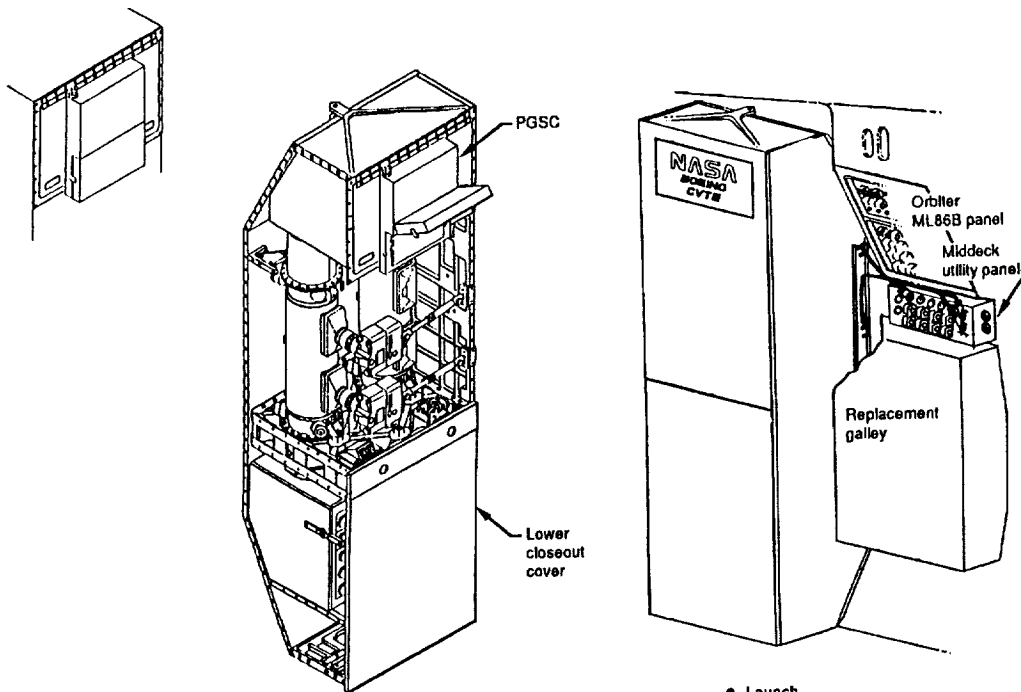

On-orbit start up and operation (2 furnaces)  
 (MAR aft panel removed)

- Launch
- Re-entry

*Operational Configuration*

## Crystals by Vapor Transport Experiment Hardware Status

**BOEING**

### CVTE:

Undergoing final assembly and checkout at KSC  
 Turnover to KSC personnel August 20  
 STS-52 launch October 15

### SEF:

Environmental test program starts August 10  
 Demonstration testing in September  
 Delivery to UAH November 2

## Crystals by Vapor Transport Experiment System Requirements

**BOEING**

### Transparent Furnace

#### Temperature repeatability

Furnace to Furnace  $\pm 5^{\circ}\text{C}$   
Coil Setpoint  $< \pm 1^{\circ}\text{C}$

Provide a suitable environment for growing large single crystals of CdTe

850°C centerline temperature  
Thermal gradient  $10^{\circ}\text{C}/\text{cm} < dt/dx < 50^{\circ}\text{C}/\text{cm}$   
Centerline temperature variation: Max  $< \pm 0.1^{\circ}\text{C}$   
RMS  $< \pm 0.025^{\circ}\text{C}$

August 5, 1992 8

## Crystals by Vapor Transport Experiment System Requirements

**BOEING**

Pull rate:  $1 \text{ mm/day} < dl/dt < 25 \text{ mm/day}$

System set-up time not to exceed 30 minutes

Independent electronics, software, and cooling control

Safe operation

Must function in both ground research and flight operation environments

Must meet shuttle middeck environmental requirements

August 5, 1992 9



## **Crystals by Vapor Transport Experiment Integration: Lessons Learned**

**BOEING**

### **Chief Program Scientist Responsibilities:**

**Responsible to the Program Manager  
Not necessarily a PI for the flight  
Primary I/F with science and academic communities**

**Develop: Science requirements  
Ground and flight experiment plans**

**Provide inputs: Engineering design  
Software design**

**The Chief Scientist must have equal authority to the  
Chief Engineer.**

August 5, 1992 10

## **Crystals by Vapor Transport Experiment Integration: Lessons Learned**

**BOEING**

### **Principal Investigator Involvement:**

**Compatibility with ground and flight H/W required**

**Access to the ground and flight hardware prior to  
flight required**

**Time for confidence building between the resident  
science/engineering team and PI's essential**

**PI involvement in crew training, flight procedure  
development and mission support must be  
negotiated early in the program**

August 5, 1992 11

## Crystals by Vapor Transport Experiment Integration: Lessons Learned

**BOEING**

### Principal Investigator Involvement:

**Conflict between NASA, engineering and science requirements exists. Compromise is critical to program success**

**The experiment that is finally flown may not be the original concept due to incompatible requirements**

August 5, 1992 12

## Crystals by Vapor Transport Experiment Integration: Lessons Learned

**BOEING**

**Be prepared for the cost of flight integration**

**Critical integration requirements include:**

**Safety Reviews  
Operation/Procedure Development  
Analyses  
Crew Training  
Qualification Testing**

**Minimize Rework!**

August 5, 1992 13

## Crystals by Vapor Transport Experiment Integration: Lessons Learned

**BOEING**

### Understand who the players are:

**Boeing: Engineering and Science**

**NASA/HQ: Sponsor**

**NASA/JSC: Integration**

**NASA/MSFC: JEA Administration**

**NASA/KSC: Launch Site Support and H/W  
installation**

**PI: Science**

August 9, 1992 14

## Crystals by Vapor Transport Experiment Integration: Lessons Learned

**BOEING**

### Joint Endeavor Agreement:

**JEA is a flawed document for use with a complex  
payload**

**No traditional "contractual coverage"**

**Program advocate or Mission Manger is needed  
to represent the payload through integration**

August 9, 1992 15

## **Crystals by Vapor Transport Experiment Integration: Lessons Learned**

**BOEING**

### **Flight Documentation Development:**

**Establish detailed interface requirements early**

**Establish controlling documentation early**

**Safety Reviews: Understand which system drives the requirement**

**Maintain communication and cooperation with the group responsible for hardware integration**

August 5, 1992 18

## **Crystals by Vapor Transport Experiment Integration: Lessons Learned**

**BOEING**

**In order to prepare experiments for use on the Space Station the following must be considered:**

**Chief Scientist with appropriate authority is key**

**Contractual instrument to define requirements is critical**

**Program advocate is a plus**

**Flexibility to react is essential**

**CVTE is a flight ready materials processing facility adaptable to Space Station Freedom.**

August 5, 1992 17