

511-33

160525

p. 12

N 93-27737

Effect of Cooling on the Efficiency of Schottky Varactor Frequency Multipliers at Millimeter Waves

Jyrki Louhi¹, Antti Räisänen¹, Neal Erickson²

¹ Helsinki University of Technology, Radio Laboratory, SF-02150 Espoo, Finland

² Five College Radio Astronomy Observatory, University of Massachusetts, 619 Lederle Graduate Research Center, Amherst, MA 01003, USA

Abstract

The efficiency of the Schottky diode multiplier can be increased by cooling the diode to 77 K. The main reason for better efficiency is the increased mobility of the free carriers. Because of that the series resistance decreases and a few dB higher efficiency can be expected at low input power levels. At high output frequencies and at high power levels the current saturation decreases the efficiency of the multiplication. When the diode is cooled the maximum current of the diode increases and much more output power can be expected. There are also slight changes in the $I - V$ characteristic and in the diode junction capacitance, but they have a negligible effect on the efficiency of the multiplier.

1 Introduction

It is well known, that cooling a Schottky diode mixer improves its sensitivity, i.e. reduces the mixer noise temperature. This is mainly due to the sharper $I - V$ characteristic at cryogenic temperatures, only partly due to the smaller series resistance and lower metal losses in the mixer mount. In satellite applications the heterodyne receiver is readily cooled passively to temperatures of 110...150 K. Also, a space qualified 80 K cooler is available. This makes it very reasonable to consider the effect of cooling on the frequency multiplier performance. This is especially important at submillimeter waves, where not enough power is available from ordinary all-solid-state frequency multipliers.

2 Diode model and effect of cooling

A simple equivalent circuit of the Schottky diode contains three components: non-linear junction capacitance, nonlinear junction conductance and series impedance [1].

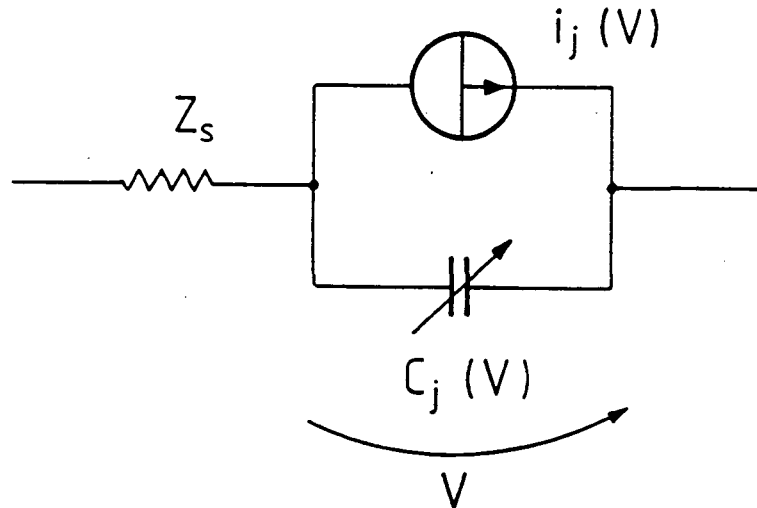

Figure 1: Simple equivalent circuit of the Schottky diode.

Capacitance

The basic model for the junction capacitance of the Schottky diode is

$$C_j(V) = \frac{C_0}{\sqrt{1 - V/\phi_{bi}}}, \quad (1)$$

where ϕ_{bi} is the built-in potential (about 1 V) and C_0 is diode capacitance, when the voltage over the junction is zero. For very small submillimeter wave diodes the edge effect must be included in the diode model as [2]

$$C_j(V) = \frac{A \cdot \epsilon_s}{w(V)} \cdot \left(1 + \frac{3 \cdot w(V)}{2 \cdot r_a} \right) \quad (2)$$

$$w(V) = \sqrt{\frac{2 \cdot \epsilon_s}{q \cdot N_D} \cdot \left(\phi_{bi} - V - \frac{k_0 \cdot T}{q} \right)}, \quad (3)$$

where A is the anode area, ϵ_s is the dielectric constant of the semiconductor, $w(V)$ is the length of the depletion region, r_a is the anode radius, q is the charge of an electron, N_D is the doping density in the semiconductor, k_0 is Boltzmann's constant and T is the temperature. In these models the junction capacitance is very high near the contact potential ϕ_{bi} . Physically this is impossible, and a better model for junction capacitance must be calculated by using the drift-diffusion model [3]. In any of the models, the primary mechanism for the efficiency of the multiplier, the degree of capacitance nonlinearity, is not temperature dependent. Thus, cooling has no effect on the diode's inherent capability to generate harmonics. In the two simple models the only temperature dependent factor is ϕ_{bi} .

When the diode is cooled from 300 K to 77 K, the contact potential ϕ_{bi} increases by about 0.1 V [4]. Because ϕ_{bi} varies only slightly when the diode is cooled, the same operation point can be reached if the bias potential V_{Bias} is also increased as much as ϕ_{bi} . In all, the effect of cooling on the junction capacitance is so small that it has an almost negligible effect on the multiplier efficiency.

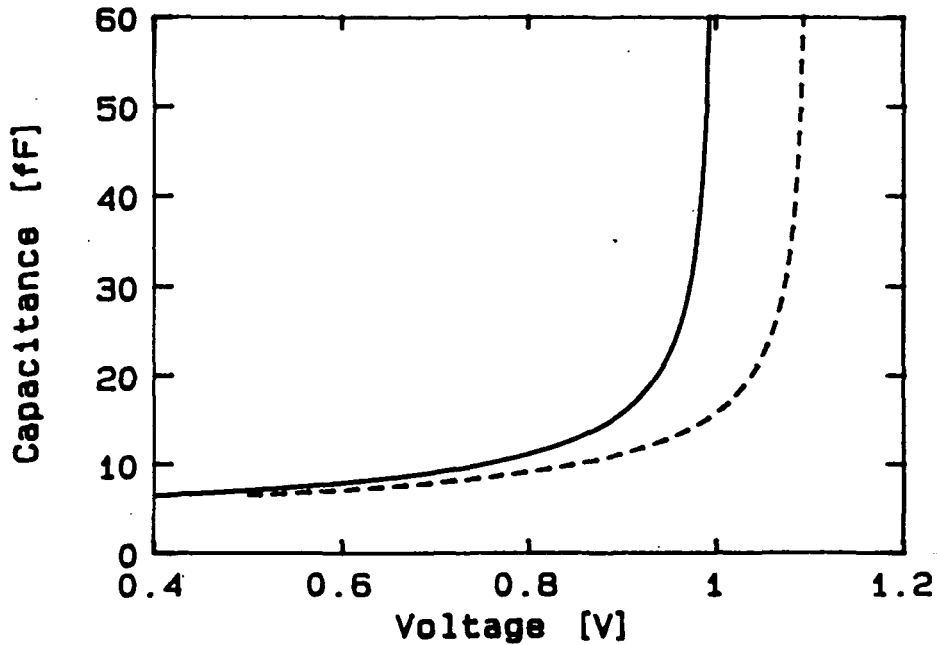

Figure 2: The junction capacitance at temperatures 300 K (solid line) and at 77 K (dashed line).

Series impedance

When the nonlinearity of the epitaxial layer above the plasma resonance is not included, the series impedance of the submillimeter wave Schottky diode is modeled as [5]

$$Z_s(\omega) = Z_{epi}(\omega) + Z_{sub}(\omega) + Z_{skin}(\omega) + R_c \quad (4)$$

$$Z_{epi}(\omega) = \frac{\rho_{epi} \cdot t_e(eff)}{A} \cdot \left[\frac{1}{1 + j\omega/\omega_s} + j\frac{\omega}{\omega_d} \right]^{-1} \quad (5)$$

$$Z_{sub}(\omega) = \frac{\rho_{sub}}{4 \cdot \tau_a} \cdot \left[\frac{1}{1 + j\omega/\omega_s} + j\frac{\omega}{\omega_d} \right]^{-1} \quad (6)$$

$$Z_{skin}(\omega) = \sqrt{2j} \cdot \frac{\rho_{sub}}{2\pi \cdot \delta_s} \cdot \ln\left(\frac{b}{\tau_a}\right) / \sqrt{1 + j\omega/\omega_s + j\frac{\omega}{\omega_d}}, \quad (7)$$

where R_c is the contact resistance (about 1 Ω), ρ is resistivity, $t_e(eff)$ is $t_e - w(V_{bias})$, t_e is the thickness of the epitaxial layer, b is the radius of the chip and δ_s is the skin depth in the substrate given by

$$\delta_s = \sqrt{\frac{2 \cdot \rho_s}{\omega \cdot \mu_0}}, \quad (8)$$

where μ_0 is permeability of GaAs. Scattering frequency ω_s and dielectric relaxation frequency ω_d are

$$\omega_s = \frac{q}{m^* \cdot \mu_s}, \quad (9)$$

$$\omega_d = \frac{1}{\rho_s \cdot \epsilon_s}, \quad (10)$$

where m^* is the effective carrier mass and μ_s is the carrier mobility. The resistivity is

$$\rho = \frac{1}{q \cdot n \cdot \mu_s}, \quad (11)$$

where n is the concentration of the free electrons in the conduction band.

In a semiconductor, the concentration of the free carriers n and the mobility of the carriers μ_s are the most important temperature dependent factors in equations given above. In GaAs the donor binding energy E_D is so small and the concentration of donors N_D is usually so high that the concentration of the free carriers n is equivalent to N_D at all temperatures, where the diode should be used. At a very cold temperature, below 10 K, the concentration drops, because there is not enough thermal energy to ionize electrons to the conduction band, and so the resistivity of GaAs becomes high. At very high temperatures the concentration of the intrinsic carriers is higher than N_D , and thus n is also higher than N_D .

In GaAs the mobility of the free carriers can be calculated from the mobilities of the various scattering processes by using the Matthiessen rule

$$\frac{1}{\mu_s} = \sum \frac{1}{\mu_i}. \quad (12)$$

In GaAs the most important scattering processes are the ionized impurity scattering, acoustic-mode scattering and polar-optical scattering. At room temperature, the polar-optical scattering dominates. When GaAs is cooled, the mobility increases until the mobility of the polar-optical scattering and the mobility of the impurity scattering are equal. At that temperature, mobility μ_s has a maximum, and when the diode is cooled more the mobility decreases. When N_D is rather low ($1 \cdot 10^{16} \text{cm}^{-3}$) the optimum temperature is low (~ 50 K) and the mobility greatly increases [6]. At very high doping concentration ($2 \cdot 10^{17} \text{cm}^{-3}$) the optimum temperature is higher (~ 150 K) and the mobility increases only a little when the diode is cooled to 77 K.

When considering the effect of cooling on the series impedance of the Schottky diode, it is simplest to consider first its effect on the DC resistance and then the effect on the series impedance at high frequencies. When the diode is cooled to 77 K, the mobility of electrons increases and thus the resistivity of the epitaxial layer decreases, which also decreases the DC resistance of the diode. When the doping concentration of the epitaxial layer is low, the DC resistance decreases significantly. (For diode UVA 6P2 the measured decrease is about 4.5Ω , from a

value of 10.5Ω to 6Ω ; the calculated values agree very well, see Figure 3) When the doping rate is higher the decrease of the resistance is not as large. (For diode UVA 2T2 the calculated decrease is about 3.5Ω , from a value of 12Ω to 8.5Ω) When considering the effect of the decreased series resistance on the efficiency of the multiplication, it must be noticed that the resistance of the epitaxial layer Z_{epi} is a function of the thickness of the layer. In an efficient reactive multiplication, the voltage over the depletion region spends a substantial part of the pump cycle in the low voltage region, where the contribution of Z_{epi} in Z_s is large, but a small part of the pump cycle in the high reverse voltage region, where the contribution of Z_{epi} in Z_s is small. When the diode is now cooled, the decrease of the series resistance is smaller than the decrease of the DC resistance, but still the decrease of resistance has a very strong positive effect on the efficiency of multiplication.

At high frequencies the series impedance of the Schottky diode is no longer purely resistive, because of the plasma resonance and the skin effect. When the diode is cooled, the plasma resonance frequency

$$\omega_p = \sqrt{\omega_s \cdot \omega_d} = \sqrt{\frac{n \cdot q^2}{m^* \cdot \epsilon_s}} \quad (13)$$

does not change, because it is independent of the electron mobility μ_s . Because ω_s and ω_d are temperature dependent, the Q-factor of the resonance is also temperature dependent, and when the diode is cooled to 77 K the Q is increased (Figure 3). Because the mobility in the substrate changes only very little when the diode is cooled, the impedance of the substrate Z_{sub} and the impedance of the skin effect are not changed significantly.

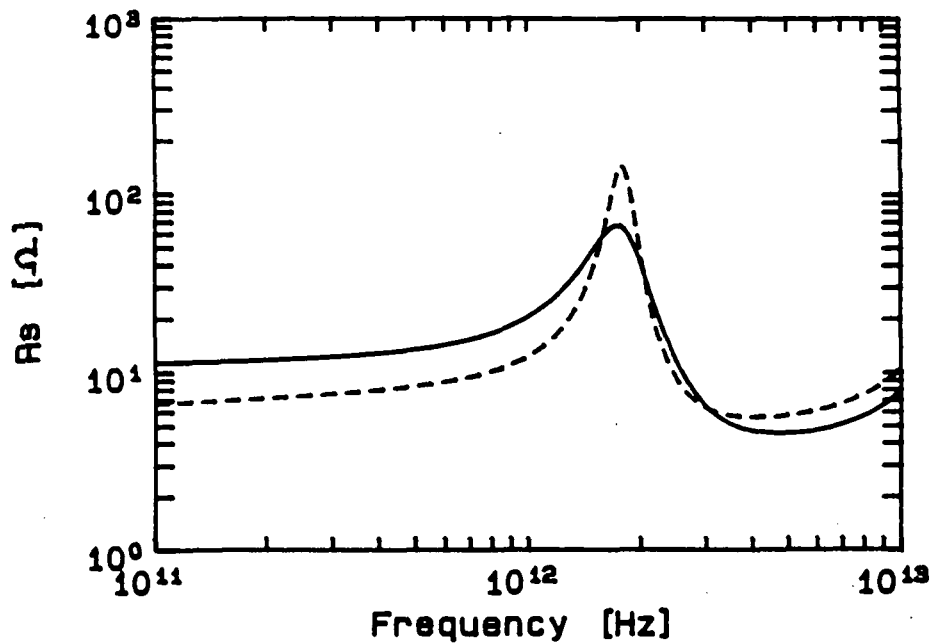

Figure 3: The series resistance of diode UVA 6P2 at temperatures 300 K (solid line) and 77 K (dashed line).

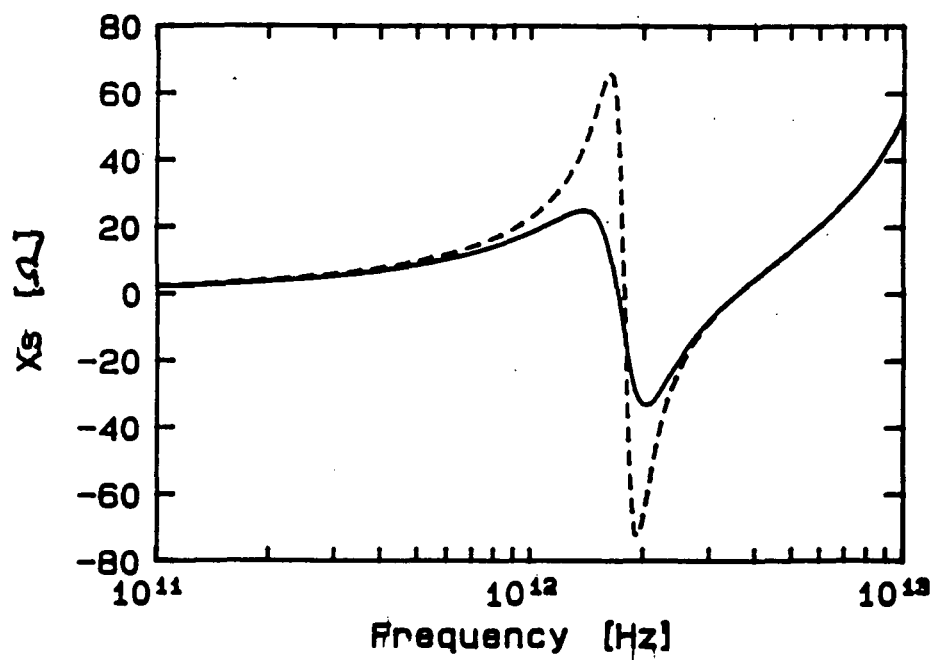

Figure 4: The series reactance of diode UVA 6P2 at temperatures 300 K (solid line) and 77 K (dashed line).

I-V characteristic

For a Schottky diode the $I - V$ characteristic is assumed to be [4]

$$I_j(V) = A \cdot R^{**} \cdot \theta^2 \cdot e^{q(V-\phi_{bi})/k_0\theta} \quad (14)$$

$$\theta = \theta_f \cdot \coth\left(\frac{\theta_f}{T}\right) \quad (15)$$

$$\theta_f = \frac{q \cdot \hbar}{k_0} \cdot \sqrt{\frac{N_D}{4 \cdot \epsilon_s \cdot m^*}} \quad (16)$$

where R^{**} is modified Richardson's constant, \hbar is $h/2\pi$ and h is Planck's constant.

There are two important factors of the $I - V$ characteristic for the efficiency of the frequency multiplication: the turn-up point of the $I - V$ curve, and the steepness of the $I - V$ curve beyond that. When the Schottky diode is cooled, the possible voltage range where the multiplication is mainly reactive, increases, and thus the maximum efficiency can also increase. For a cooled diode the shape of the $I - V$ characteristic is also sharper, and therefore the resistive multiplication is slightly more effective.

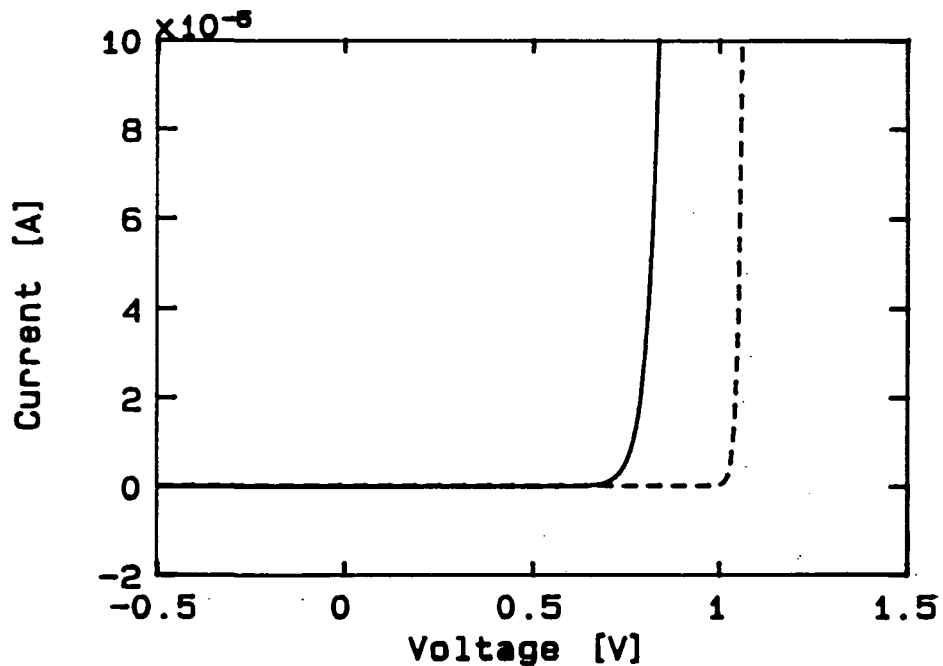

Figure 5: The current-voltage characteristic at temperatures of 300 K (solid line) and 77 K (dashed line).

Current saturation

At a low electric field the electron drift velocity v_d is directly related to the electric field \mathcal{E} as

$$v_d = \mu_s \cdot \mathcal{E}. \quad (17)$$

When the electric field increases the drift velocity also increases until the velocity reaches a maximum value v_{max} ($= 2.2 \cdot 10^5$ m/s at about 3.2 kV/cm in an intrinsic case). In that situation the electron conduction current

$$i_e = A \cdot n \cdot q \cdot \mu_s \cdot \mathcal{E} \quad (18)$$

must be replaced by the maximum current

$$i_{max} = A \cdot n \cdot q \cdot v_{max}. \quad (19)$$

This current saturation causes a very significant decrease in the efficiency of the multiplier at high power levels and also when the output frequency is high, because the junction capacitance cannot be pumped with optimum current. The current saturation seems to be the most important factor for a submillimeter wave frequency multiplier, when the efficiency of the multiplication is considered. When the diode is cooled, the maximum drift velocity increases [6] and because of that the maximum electron current also increases. Therefore, when the diode is cooled the effect of the current saturation is less significant. This increases the efficiency especially at high power levels, at high frequencies, and in the case of a high multiplication factor.

The current saturation may be modelled by strongly current dependent series resistance $R_s(i)$ above the maximum current. Kollberg et al. have presented the following model [7]:

$$R_s(i) = R_s(DC) \cdot a \cdot i^6, \quad (20)$$

where a is a parameter, depending on the maximum current of the diode i_{max} . The meaning of the $R_s(i)$ is to modify the current waveform approximately as required by causing a very strong increase in the series resistance when the current of the diode is higher than the maximum current i_{max} . The parameter a has been fitted empirically to the measured results only in one case and must be estimated for other diodes and frequencies. There seems to be no physical background for this model, but so far no better model has been proposed.

3 Analysis of multipliers

At millimeter waves Schottky varactors are often driven into conduction, which is only nearly optimal. In this case, the usefulness of classical theories [8] is poor and harmonic balance analysis [9] should be used. One form of the harmonic balance analysis is the multiple reflections technique, where the multiplier circuit is divided into linear and nonlinear subcircuits, which are then analyzed in the frequency and time domain.

Doubler for 160 GHz

Let us first consider the effect of cooling on a two diode balanced doubler for 160 GHz, because we have also experimental results for it [10].

Table 1: Parameters used for UVA 6P2.

	C_0	A	t_e	N_D	μ	i_{max}
300 K	21	33	1.0	$3.5 \cdot 10^{16}$	0.61	44
77 K	21	33	1.0	$3.5 \cdot 10^{16}$	1.40	66
	fF	μm^2	μm	cm^{-3}	m/s	mA

The two diode construction has been analyzed both at 300 K and at 77 K. First, the efficiency has been calculated with optimum embedding impedances. These results have been plotted in Figure 6 (solid lines). Here the efficiency has only a very poor correlation with the measurements (O and X) because of the VSWR, which is mainly caused by the fact that the embedding impedances are optimized for high input power. When the doubler is then analyzed by using the optimum embedding impedances for high input power at all input power levels, the correlation is much better, especially when 0.5 dB losses in the input and 0.8 dB losses in the output have been taken into account.

Table 2: Experimental output power versus temperature and input power (two diodes).

		Input power				mW
		10	33	50	100	
Temperature	300 K	1.6	9.0	13.9	22.0	mW
	223 K	1.9	10.4	16.3	26.7	mW
	77 K	2.2	12.8	18.7	30.7	mW

In order to understand better the agreement between the theory and experiment, it is worth separating the effects of the decreased series impedance and the increased current handling capability due to the cooling. First, if the current saturation is omitted in the theoretical analysis, the effect of cooling is as follows. At low input power levels when the multiplication is purely reactive, the decreased series impedance causes a clear increase in the efficiency due to smaller losses in the series impedance. According to simulations, the increase of the efficiency in the above case at low input power levels is about 1.5 dB. However, when the input power per diode is large (i.e. > 10 mW), the multiplication efficiency tends to decrease with the increased input power due to the resistive multiplication. This

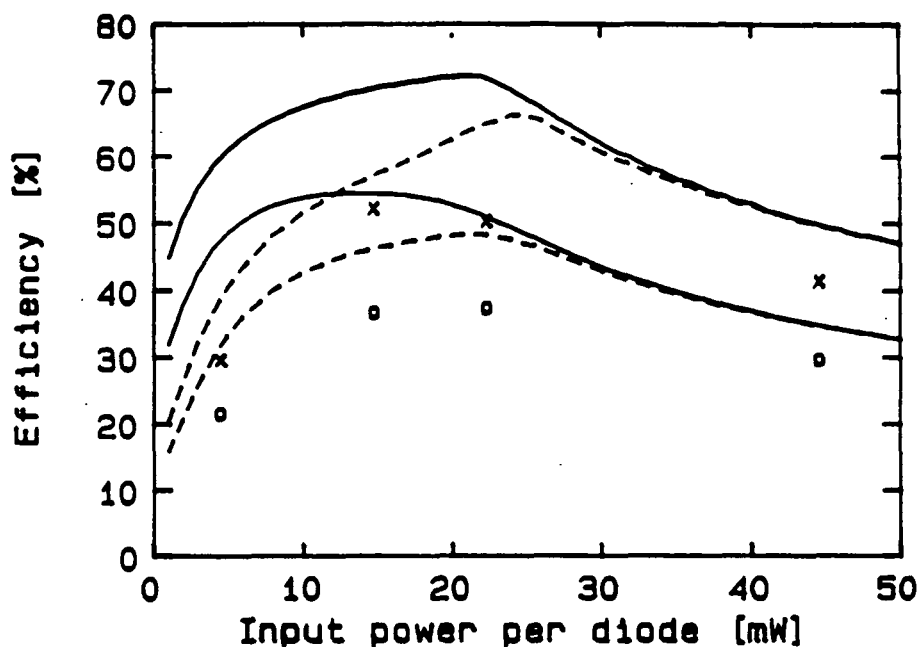

Figure 6: The efficiency of the 160 GHz doubler at 300 K and at 77 K (above), when using optimum impedances (solid line) and impedances optimum for high power (dashed line). Measurement results, when 0.5 dB input losses and 0.8 dB output losses have been taken into account, at 300 K (o) and at 77 K (x) have also been plotted.

is because the voltage swing reaches the conduction region during every cycle. The smaller the series impedance, the lower the input power needed to reach this conduction, and thus, resistive multiplication. Therefore, the gain due to the smaller series impedance is smaller at high input power levels than at low power levels. According to the simulations, the efficiency increase due to the smaller series impedance in the multiplier described above is only 0.5 dB at 50 mW input power per diode.

When the current saturation is taken into account, but not the series resistance, the positive effect of cooling is seen only at high power levels. This is because the junction capacitance can be pumped at 77 K more effectively than at 300 K. At small power levels the saturation, of course, does not play an important role. According to our simulations, the higher current handling capability of the cooled diode 6P2 improves the efficiency by 1 dB at 50 mW input power per diode.

These two effects of cooling together, the decreased series impedance and the increased current handling capability, explain the experimentally verified 1.5 dB increase in the multiplication efficiency of all power levels and therefore give some kind of a proof of the current saturation in the diode at high input power levels. Due to the higher efficiency at high input power levels, the maximum output power is also increased by the same amount, which helps in pumping the following stage in the multiplier chain producing submillimeter wave frequencies.

Multipliers for 1 THz

When constructing multiplier chains for 1 THz, a reasonable choice is first to double the output frequency of a powerful W-band Gunn oscillator and then to follow by a tripler and a doubler or by a doubler and a tripler. The latter choice does not only depend on the varactor diodes but also on the technology to build fine mechanical multiplier mounts.

In order to get some understanding of how much power could be available at 1 THz, the choice of a tripler to 500 GHz and doubler to 1 THz has been made because this allows comparison with experimental results up to 500 GHz [10]. The tripler for 500 GHz and the doubler for 1 THz can be analyzed the same way as the doubler for 160 GHz, but now current saturation plays a very important role. Because the presented model for current saturation has only poor correlation to the physics, the results for high frequency multipliers should be considered only qualitatively.

Some general aspects can still be presented. First, when the diode is cooled, the maximum drift velocity increases, which also increases the maximum current. Second, when the output frequency is high, the changes during the voltage swing are very fast. In that situation, the current needed for optimum multiplication is very high, and then current saturation plays a very important role by greatly decreasing the efficiency. By cooling, the maximum current should increase and the efficiency of the multiplication may increase by a few dB. Third, when the first or second stage multiplier is cooled, the maximum input power for the last stage multiplier increases, and so also the maximum output power for 1 THz increases. Our simulations have indicated an increase of about 7 dB from 100 μ W to 500 μ W in the optimum situation.

4 Conclusions

Cooling of a Schottky varactor multiplier increases its efficiency by as much as a few dB. Because of the smaller series impedance the efficiency of frequency multiplication increases by 1-2 dB at small input power levels. At large input power levels the efficiency increases by 2-10 dB due to the higher current handling capability of the diode. A cooled multiplier can be readily used in satellite applications, where the receiver is cooled to 50...150 K. The positive effect of the cooling should be utilized especially in submillimeter wave multipliers when the output power necessary cannot be reached in any other way.

Even though the model of a Schottky diode is already rather complex, it should be studied more. The main reason for a poor model is that current saturation is poorly handled. Much more work must be done to model the saturation exactly. Also much more experimental work on cooling multipliers is needed, before all the effects of the cooling can be understood.

References

- [1] Räsänen A.V., Sironen M.: Capability of Schottky-diode multipliers as local oscillators at 1 THz. *Microwave and Optical Technology Letters*, vol. 4, no. 1, 1991, p. 29-33.
- [2] Copeland J.A.: Diode edge effect on doping-profile measurements. *IEEE Transactions on Electron Devices*, vol. ED-17, no. 5, 1970, p. 401-407.
- [3] Hjelmgren H., Kollberg E., Lundgren L.: Numerical simulations of the capacitance of forward-biased Schottky-diodes. *Solid-State Electronics*, vol. 34, no. 6, 1991, p. 587-590.
- [4] Kollberg E.L., Zirath H., Jelenski A., Temperature-variable characteristics and noise in metal-semiconductor junctions. *IEEE Transactions on Microwave Theory and Techniques*, vol. MTT-34, no. 9, 1986, p. 913-922.
- [5] Crowe T.W.: GaAs Schottky barrier mixer diodes for the frequency range 1-10 THz. *International Journal of Infrared and Millimeter Waves*, vol. 10, no. 7, 1989, p. 765-777.
- [6] Ruch J.G., Fawcett W.: Temperature dependence of the transport properties of Gallium Arsenide determined by a Monte Carlo method. *Journal of Applied Physics*, vol. 41, no. 9, 1970, p. 3843-3849.
- [7] Kollberg E., Tolmunen T., Frerking M., East J.: Current saturation in submillimeter wave varactors. *Proceedings of the 2nd International Symposium on Space Terahertz Technology*, 1991, p. 306-322.
- [8] Penfield P., Rafuse R.P.: *Varactor Applications*, Cambridge, Mass., The MIT Press, 1962.
- [9] Siegel P.H., Kerr A.R., Hwang W.: *Topics in the Optimization of Millimeter - Wave Mixers*, NASA Technical Paper 2287, 1984.
- [10] Erickson N.: High efficiency submillimeter frequency multipliers. *IEEE MTT-S International Microwave Symposium Digest*, vol III, Dallas, 1990, p. 1301-1304.