

N93-27751

# Slot-line end-fire antennas for THz frequencies

by

H. Ekström, S. Gearhart\*, P. R. Acharya, H. Davé\*\*,  
G. Rebeiz\*, S. Jacobsson, E. Kollberg, G. Chin\*\*

Department of Applied Electron Physics  
Chalmers University of Technology  
S-412 96 Göteborg, Sweden

\*NASA/Center for Space Terahertz Technology  
Electrical Engineering and Computer Science Department  
University of Michigan, Ann Arbor, MI 48109-2122, USA

\*\*Planetary System Branch  
NASA/Goddard Space Flight Center  
Greenbelt, MD 20771, USA

## ABSTRACT

Tapered slot-line endfire antennas, of BLTSA type, have been fabricated on 1.7  $\mu\text{m}$  thin  $\text{SiO}_2/\text{Si}_3\text{N}_4$  ( $\epsilon_r = 4.5$ ) dielectric membranes. The antenna patterns, in the E-, H-, D- and D-cross planes, were measured at 270, 348, 370 and 802 GHz using bismuth micro bolometer detectors. The antennas have approximately 12 dB directivity, and the -10 dB beam widths are 50° and 55° in the E- and H-planes at 348 GHz, respectively. The measurements at millimeter/submillimeter wavelengths compare well with scale measurements at 45 GHz as well as with theoretical predictions. The overall results are encouraging and show that slot-line antennas can be fabricated for use at THz frequencies. Furthermore, it is shown that the very thin  $\text{SiO}_2/\text{Si}_3\text{N}_4$  membranes are strong enough to be used in practical applications.

## INTRODUCTION

Tapered slot-line antennas are often considered for integration in planar millimeter/submillimeter wave circuits; e.g. in quasi optical mixers. These antennas can be operated over a wide bandwidth and radiate wide or narrow beams. Various types of endfire slot-line antennas can be found in the literature; e.g. the linearly tapered slot-line antenna (LTSA) [1], the exponentially tapered slot-line antenna "Vivaldi" [2] and the constant width slot-line antenna (CWSA) [3]. A review of antennas suitable for integration in circuits for millimeter and terahertz frequencies has been written by G. Rebeiz [4].

In this work we have studied yet another member belonging to the family of endfire slot line antennas; namely the BLTSA (Broken Linearly Tapered Slotline Antenna) [5], Fig. 1. The BLTSA has the advantage, among the slot-line antennas, to require the small substrate area. In addition, the BLTSA has been extensively studied by the Chalmers group.

Antennas of endfire slot-line type require a certain optimum substrate thickness  $t = 0.03 \lambda (\sqrt{\epsilon_r} - 1)^{-1}$  [3] to avoid pattern degradation and power loss due to surface modes. In the millimeter wave range the thickness should be only a couple of micrometers, hence the antenna must be fabricated on a thin dielectric membrane, a fact which introduces delicate manufacturing problems. A further complication is introduced by the fact that the membranes must be left unsupported in the endfire direction, Fig. 2.

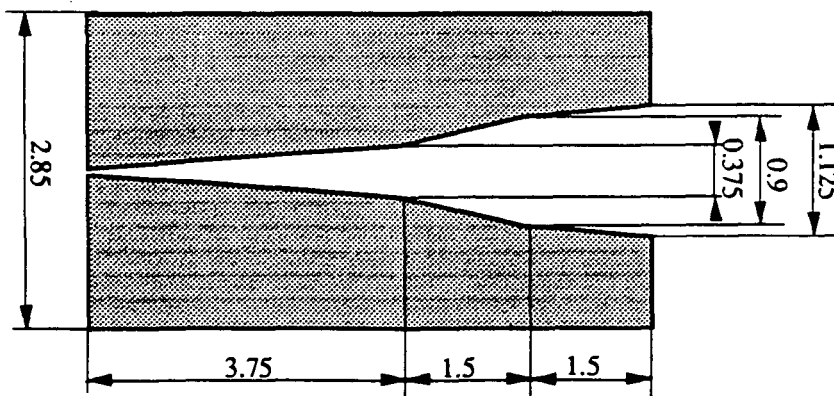

Fig. 1. Dimensions of the BLTSA. All dimensions are normalised to the vacuum wavelength.

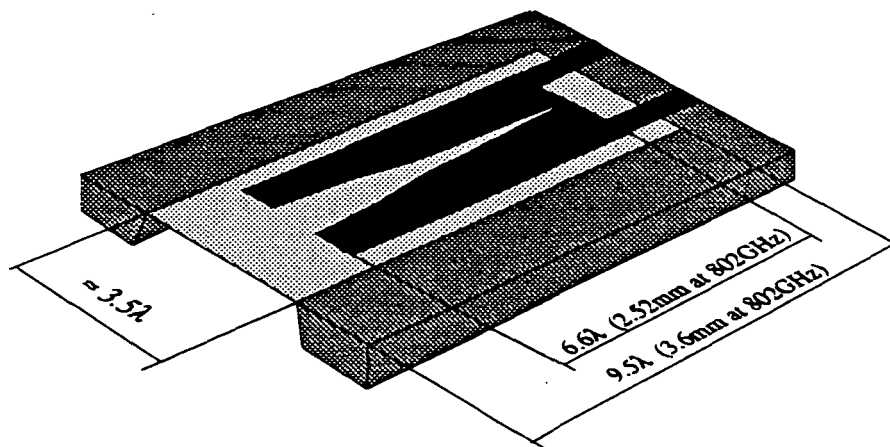

Fig. 2. The endfire slot line antenna deposited on BLTSA on 1.7  $\mu\text{m}$  thin  $\text{SiO}_2/\text{Si}_3\text{N}_4$  ( $\epsilon_r = 4.5$ ) membrane. The Si frame supporting the membrane has a thickness of 385  $\mu\text{m}$ . Note that the membrane is unsupported in the end-fire direction.

#### FABRICATION

The 1.7  $\mu\text{m}$  thin dielectric membrane supporting the antenna consists of three layers; thermally grown  $\text{SiO}_2$ , LPCVD deposited  $\text{Si}_3\text{N}_5$  and  $\text{SiO}_2$ . With compressive oxide and tensile nitride, the relative thickness of the layers could be selected to form a slightly tensile, and consequently flat and rigid membrane. The membrane layers were deposited on both sides of 385  $\mu\text{m}$  thick silicon wafers. To form the membrane region for the antennas, the silicon was etched in EDP from the backside of the wafer, with the backside nitride and oxide layers patterned with the membrane layout and used as etch mask. The nitride and oxide layers on the front side acted as etch stops for EDP. A considerably manufacturing problem is due to the fact that the antenna requires that the membrane is not supported by silicon in the endfire direction. In order to simplify the photo lithography were the antennas fabricated on fully supported membranes. After the antennas were fabricated was the silicon support in the endfire direction removed. The fragility of the membrane limits the area to roughly  $3 \times 9 \text{ mm}^2$ . Thus, the maximum available membrane size limits this particular antenna design to frequencies above 300 GHz.

#### MEASUREMENTS

Several scaled versions of BLTSA's were fabricated on 25.4  $\mu\text{m}$  thick Kapton foil and measured at 45 GHz. The best antenna design was then scaled to 348 and 802 GHz (dimensions normalized to vacuum wavelength are given in Fig. 1). These antennas were fabricated on the 1.7  $\mu\text{m}$  thin dielectric membranes, Fig. 2.

Bismuth micro bolometers were used as detectors. A Gunn oscillator with a tripler/quadrupler was used as signal source at 270 and 348 GHz, whereas an optically pumped far infrared laser was used to generate the 802 GHz signal. The dynamic range in the antenna pattern measurements was approximately 20 dB.

The E-, H-, D- and Dx- planes of the 348 GHz antenna were measured at four frequencies: 270, 348, 370 and 802 GHz, respectively, whereas the 802 GHz design was only measured at 802 GHz. Measurements of the 348 GHz design at 270 and 802 GHz, Figs. 3a, b and c, show the wide bandwidth of this type of antenna. At the design frequency the  $-10$  dB beam width varies between  $43$  and  $55^\circ$  in the measured planes. The D-plane crosspol level is as high as  $-6$  dB, which is a typical value for endfire slot-line antennas. The directivity was calculated to approximately 12 dB. In the calculations the lobes outside the measured range and the back lobes were set to  $-14$  dB and  $-20$  dB respectively.

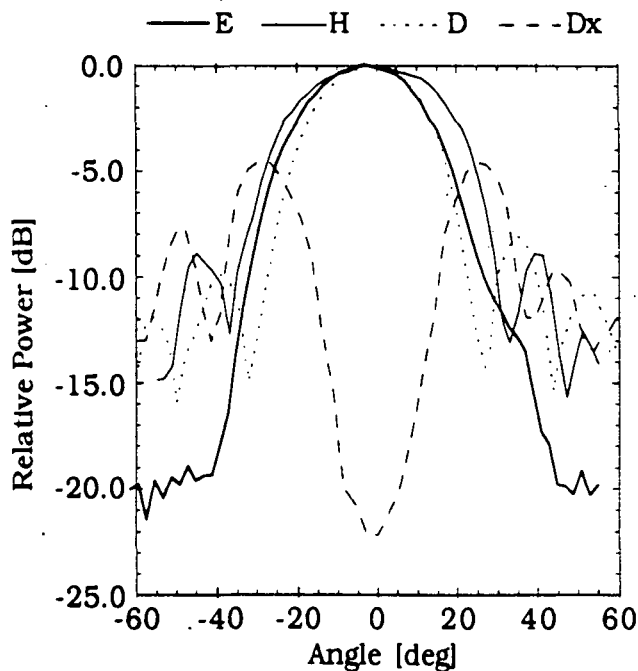

Fig. 3a. Antenna patterns for the BLTSA designed for 348 GHz but measured at 270 GHz

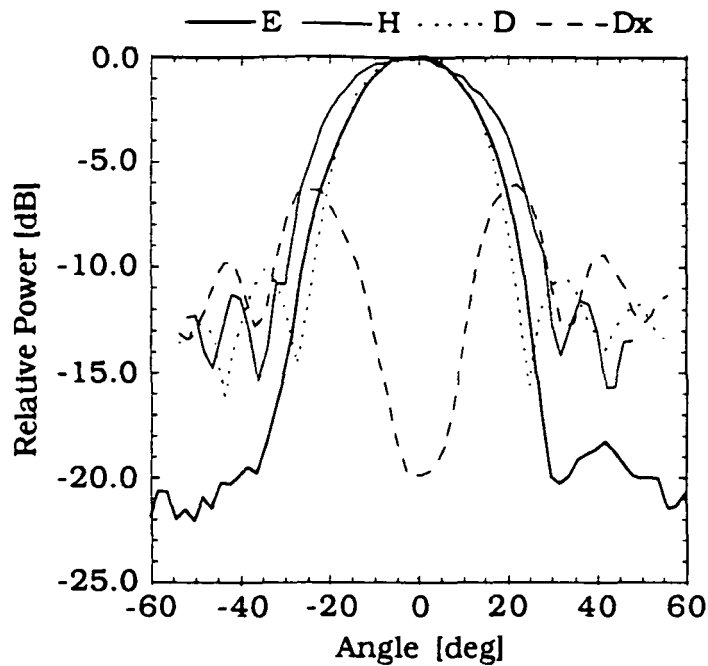

Fig. 3b. Antenna patterns for the BLTSA designed for the 348 GHz design measured at 348 GHz

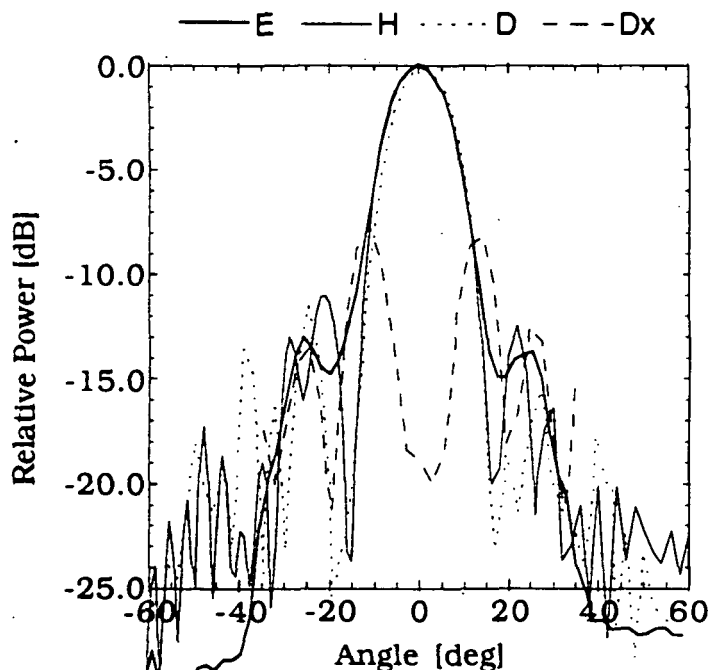

Fig. 3c. Antenna patterns for the BLTSA designed for the 348 GHz design measured at 802 GHz

At 802 GHz the antenna beam is narrower and more symmetric ( $39^\circ$  -  $43^\circ$  at  $-10$  dB level and the directivity is approximately 13 dB) with slightly lower sidelobes than the pattern at 348 GHz, also the D-plane cross-pol level is lower ( $-8$  dB), Fig. 4a, b. The improved pattern at 802 GHz was expected since the membrane is relatively thicker

(expressed in wavelengths) and closer to the optimum thickness. In fact, the optimum frequency for these membranes is approximately 4 THz. Thus, at THz frequencies, it is expected that the antenna pattern would be even more symmetric and the D-plane crosspol level could be as low as -10 to -15 dB below the co-polarized level.

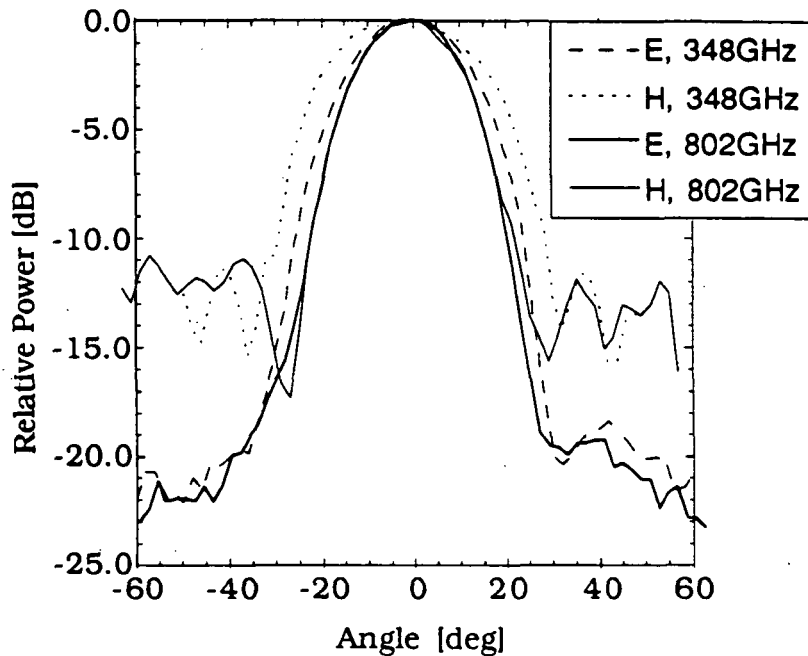

Fig. 4a. Measured E- and H plane of the 802 GHz design at 802 GHz, and the 348 GHz design at 348 GHz

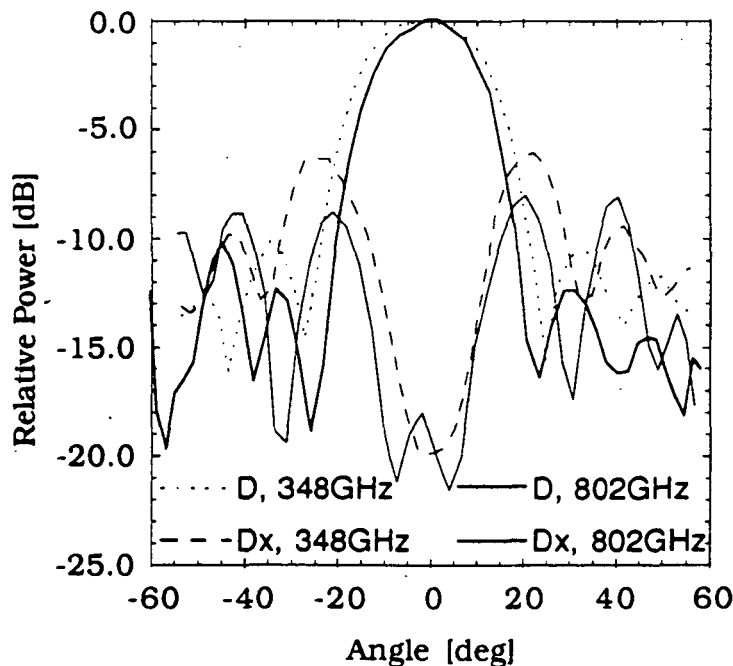

Fig. 4b. Measured D- and Dx plane of the 802 GHz design at 802 GHz, and the 348 GHz design at 348 GHz

The performance of the BLTSA end-fire antennas on 1.7  $\mu\text{m}$  thin membranes is summarized in the table below.

Frequency	GHz	270	348	370	802
E-plane	-10 dB beam width	59°	50°	49°	43°
	side lobe level	-12	-19	-19	-20
H-plane	-10 dB beam width	64°	55°	53	44°
	side lobe level	-8	-11	-11	-11
D-plane	-10 dB beam width	50°	43°	42°	39°
	side lobe level	-7	-10	-10	-12
D-cross	lobe level	-4	-6	-6.5	-8
Directivity	dB	11	12	12	13

Table 1. Compiled measured antenna data. All antennas were fabricated on a 1.7  $\mu\text{m}$  thick  $\text{SiO}_2/\text{Si}_3\text{N}_4$  membrane. The thick frames around 348 and 802 GHz indicate the design frequencies. The 348 GHz antenna was also measured at 270, 370 and 802 GHz. The 802 GHz antenna was only measured at 802 GHz.

Scale measurements at 45 GHz show that the E and H-plane patterns agree reasonably well with the patterns at the higher frequencies, Fig. 5. These antennas were made on 25.4  $\mu\text{m}$  thick Kapton™ foil ( $\epsilon_r \approx 3.5$ ). Note that, this substrate thickness is comparatively thicker (measured in wavelengths) at the scale frequency than the thickness of the dielectric in the 270 - 802 GHz measurements.

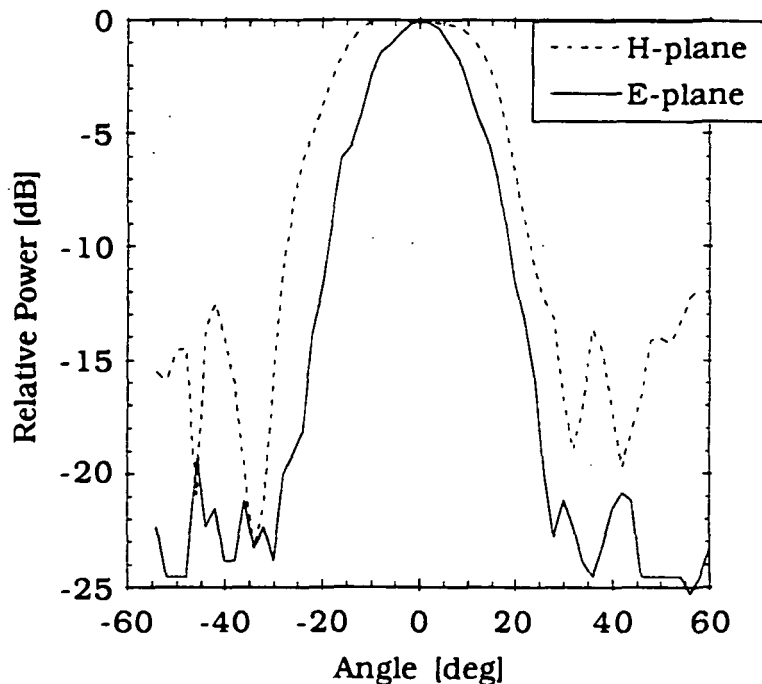

Fig. 5. E and H-plane patterns of a scale model of the BLTSA. The measurements are performed at 45 GHz.

## THEORY

The end-fire slot-line antennas have been analyzed by using method previously described by *e.g.* Janasawamy [6]. In this method, the antenna tapering is approximated by a "staircase"-function in a number of steps of different widths but equal lengths, as shown in figure 6. Thus, the slot-line antenna can now be treated as a linear array of apertures each fed with different phases and amplitudes. Furthermore, power conversion is applied to relate the amplitudes and fields in neighbouring apertures. The characteristic impedance and the wavelength of each slot is calculated by using a spectral domain technique [7]. The far field pattern of the antenna is calculated by applying an appropriate Green's function and adding the field contributions from all apertures. In these calculations we ignore the reflections from the discontinuities in the antenna taper (which has been confirmed in computer simulations).

The theoretical patterns agree reasonably well with measured patterns, Fig. 7, 8, considering the approximations in the calculations. The calculated and measured beam width correspond very well, and it is possible to predict level and position of the side-lobes within 2 dB and 5°. The biggest difference between the calculated and measured patterns is in the crosspolarized D-plane, where the theory predicts a level 2-3 dB higher than the measured level.

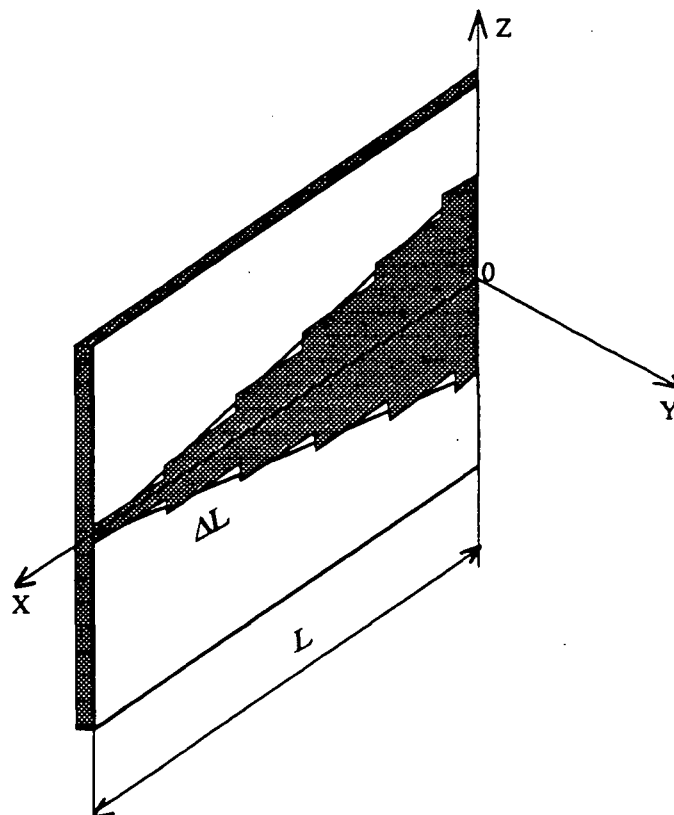

Fig. 6. Approximation of the slot-line antenna by an array of slots.



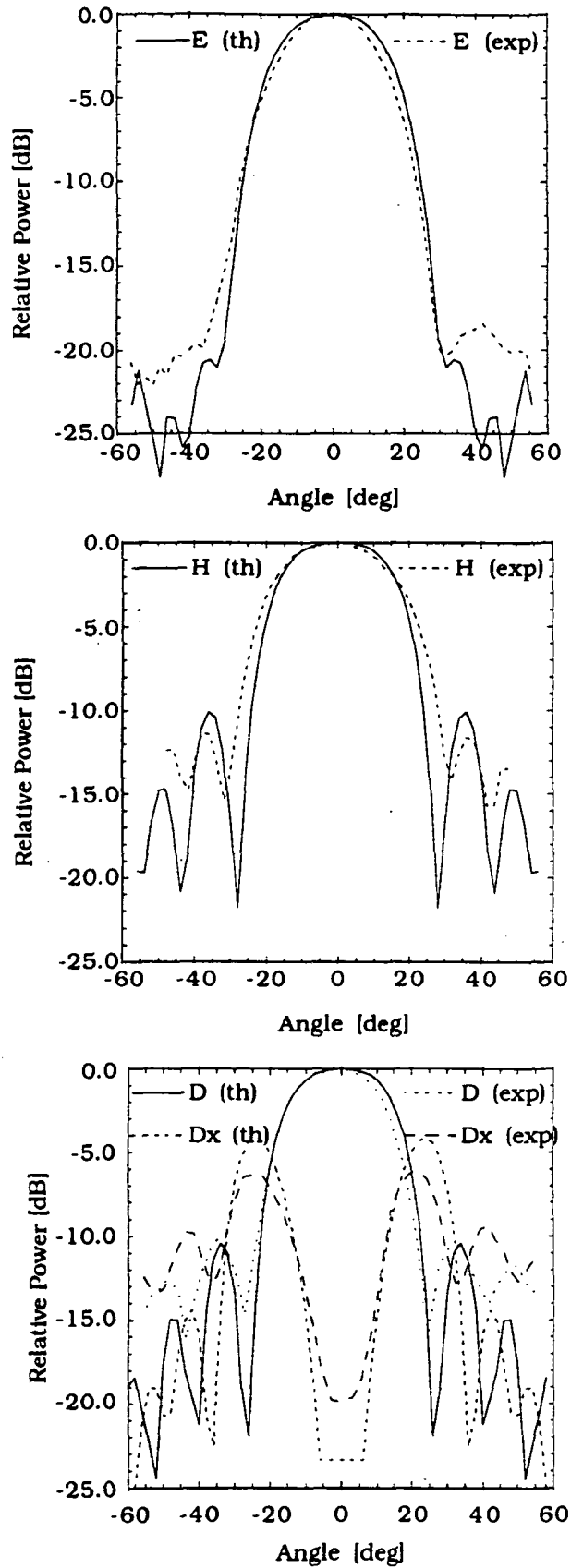

Fig. 7. Calculated (th) and measured (exp) antenna patterns at 348 GHz

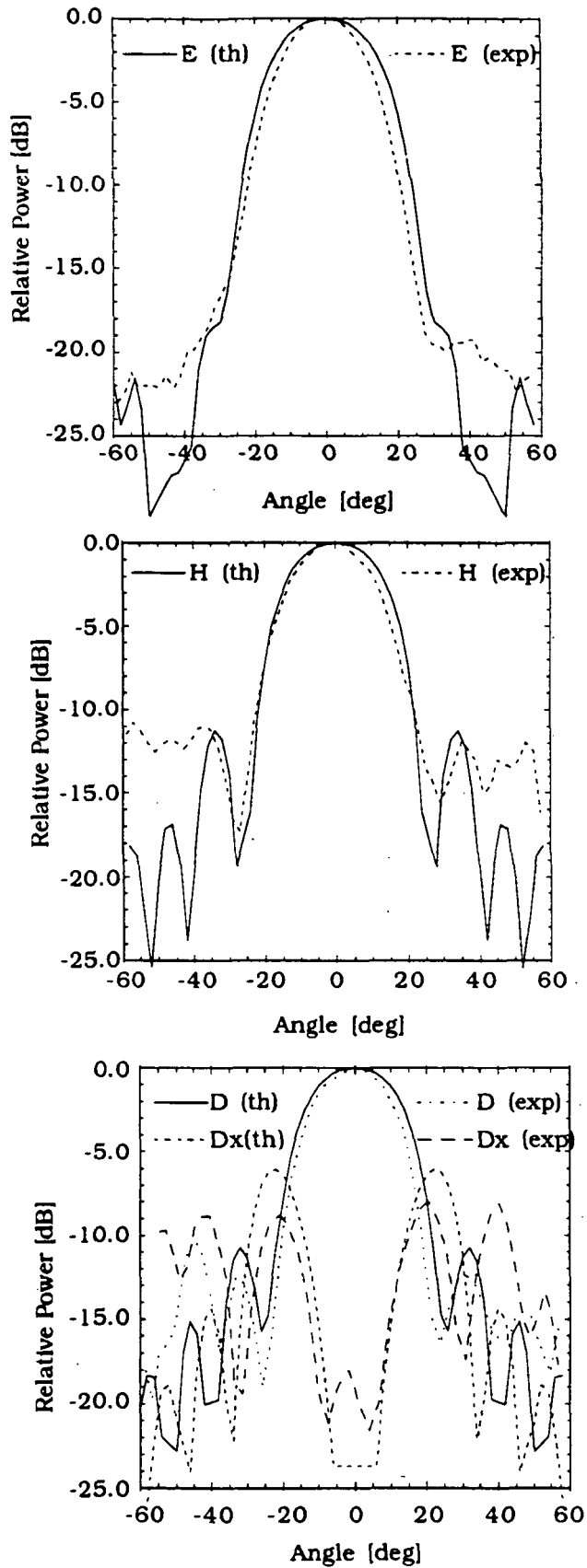

Fig. 8. Calculated (th) and measured (exp) patterns at 802 GHz

## REFERENCES

- [1] S.N. Prasad, and S. Mahapatra, *A novel MIC slot-line aertal*, Proc. 9th Eur. Microwave Conf., pp. 120-124, Brighton, UK, 1979.
- [2] P.J. Gibson, *The Vivaldi aertal*, 9th Eur. Microwave Conf., pp. 101-105, Brighton, UK, 1979.
- [3] K.S. Yngvesson, D.H. Schaubert, T.L. Korzeniowski, E.L. Kollberg, T. Thungren, and J. Johansson, *Endfire tapered slot-line antennas on dielectric substrates*, IEEE Trans. Antennas. Propagat., vol. AP-33, N.12, pp1392-1400, 1985.
- [4] G. Rebeiz, *Millimeter-wave and terahertz integrated-circuit antennas*, preprint, to appear in the October issue on Space terahertz Technology in the IEEE-Proceedings.
- [5] P.R. Acharya, J. Johansson, and E.L. Kollberg, *Slotline antennas for millimetre and sub millimetre wavelengths*, Proc. 20th Eur. Microwave Conf., pp. 353-358, Budapest, Hungary, Sept 1990.
- [6] R. Janasawamy, D. Schaubert, *Analysls of Tapered Slotline Antenna*, IEEE Trans. Antennas Propgat., vol. AP-35, no.9, pp. 1058-1065, Sept. 1987.
- [7] G. Johansson, P.R. Acharya, J. Johansson, *Determination of Slot Line Characteristics*, Technical Report No. 97L, 1991, Chalmers University of Technology.