



FILE COPY
NO. 3

TECHNICAL MEMORANDUMS
NATIONAL ADVISORY COMMITTEE FOR AERONAUTICS

No. 815

AUTOMATIC STABILIZATION

By Fr. Haus

L'Aéronautique, March 1936

THIS DOCUMENT ON LOAN FROM THE FILES OF
NATIONAL ADVISORY COMMITTEE FOR AERONAUTICS
LANGLEY MEMORIAL AERONAUTICAL LABORATORY
LANGLEY FIELD, HAMPTON, VIRGINIA

RETURN TO THE ABOVE ADDRESS.

REQUESTS FOR PUBLICATIONS SHOULD BE ADDRESSED
AS FOLLOWS:

NATIONAL ADVISORY COMMITTEE FOR AERONAUTICS
1724 S. W. WASHINGTON, D. C.

Washington
December 1936

THIS DOCUMENT ON LOAN FROM THE FILES OF
NATIONAL ADVISORY COMMITTEE FOR AERONAUTICS
LANGLEY MEMORIAL AERONAUTICAL LABORATORY
LANGLEY FIELD, HAMPTON, VIRGINIA

RETURN TO THE ABOVE ADDRESS.

REQUESTS FOR PUBLICATIONS SHOULD BE ADDRESSED
AS FOLLOWS:

NATIONAL ADVISORY COMMITTEE FOR AERONAUTICS
1724 S. W. WASHINGTON, D. C.

NATIONAL ADVISORY COMMITTEE FOR AERONAUTICS

TECHNICAL MEMORANDUM NO. 815

AUTOMATIC STABILIZATION*

By Fr. Haus

IV. AUTOMATIC STABILITY OF DIRECTION OR COURSE (Continued)

18. Gyroscopic Course Stabilizers

1) Principle of directional gyroscope.- Visualize a directional gyroscope mounted on two gimbal rings C_1 and C_2 (fig. 1), and two pivots A_1 and A_2 .

In a motion about the pivots A_1 the axis of rotation of the gyroscope remains horizontal. In a rotation of the outer ring C_2 about A_2 the gyroscope remains pointing in the same direction. Several such course stabilizers have been built on this principle. These instruments will be of value only as far as the gyroscope keeps pointing in the original direction.

The causes leading to the precession of the gyroscope and which move its axis, in azimuth, by precession about pivots A_2 , are the couples acting on pivots A_1 .

Unless the gyroscope and the frame C_1 are exactly balanced, the gravity produces a permanent couple about A_1 ; and this couple makes the gyroscope precess about axis A_2 , one of the fundamentals of gyroscopes, so well illustrated by the spinning tops and toy gyroscopes.

If substantial pitching motions induce the ring C_1 to pivot on its supports, the friction exerts a slight couple on axis A_1 , which must manifest itself by a motion of precession about A_2 . However, the successive pitching motions being in inverse direction, the precessions will be in the opposite direction and will not affect the direction of the axis much.

*"La stabilisation automatique." (Continuation of T.M. No. 802.) From L'Aéronautique, March 1936, pp. 29-37.

Lastly, as the desired stabilization should be with respect to a direction fixed on the ground, its apparent movement with respect to the meridian may be counted as movement of the gyroscope. The subsequent descriptions of the instruments show how the designers have tried to overcome possible precessions.

2) The S.E.C.A.T. apparatus.- This instrument (fig. 2) is very simple. It carries the gyroscope mounted on two rings. A plate carrying two sectors with a neutral position formed by an insulator in the center, is integral with the ring A_2 . A brush providing the contact with one or the other sector, moves in front of them. As soon as the brush has left the neutral position and faces one of the sectors, the rudder on the corresponding side is deflected, but at the same time a servo control moves the brush so as to make the deflection of the control proportionate to the change.

The operation of the instrument is readily seen from the sketch. The plate with the sector being integral with frame C_2 , it is imperative that the axis of the gyroscope be orientated in the direction it is to follow.

In the case of banking, it is necessary to impede the rotation of the gyro about its axis A_2 and not to release it until at the moment the airplane is headed on the new course which it is to follow.

To meet these requirements the gyroscope and the ring C_1 are housed in a cone-shaped cover which fits over a female cone at the instant the locking of the gyroscope is desired. The banking control is obtained by actuating the locking mechanism of the gyroscope and cutting the current supplied by the brush. Then the pilot gives the rudder the desired deflection either by direct action on the rudder bar or by sending through a special commutator - the current to the servomotor of the rudder.

Care must be taken to release the gyroscope from the cone-shaped cover at the moment the airplane is headed exactly in the desired direction.

3) The Sperry instrument.- The Sperry directional stabilizer (fig. 3) has a gyroscope mounted in the same fashion, the frame C_2 being integral with a valve shown in the sketch as a semicircular plate.

The gyroscope is placed in an enclosure kept under negative pressure by a venturi. Its rotation is obtained by directing a jet of air at outside pressure against vanes cut in the periphery of the rotor.

The plate forming the valve moves in front of two pipes leading to a pneumatic relay. Depending on the position of the valves, the pipes exert a more or less energetic suction in the two cells or grids of the relay whence, under the effect of the thus produced pressure difference, one membrane shifts the control of the air or oil inlet of the servomotor on the control. The servo-control shifts the pipes as soon as the servomotor operates, by bringing the openings before the plate. The principle of the instrument does not demand that the axis of the gyroscope be pointed on the desired course, although the design appears to require it.

The course can be changed by means of a knob E, which modifies the connection between the pipes and the rudder. The shifting of the pipe relative to the valve plate sets the rudder in motion. It cannot return to neutral until the pipe has been made to face the plate by a bank of the airplane in the inverse sense of the rotation communicated by the pipe. A second knob F allows the axis of the gyroscope to be moved at any instant. This permits ruddering over to the new course, and to maintain the axis in that direction, making the necessary corrections (usually every fifteen minutes) by comparison with the magnetic compass readings.

It is to be noted that these corrections constitute a forced precession which produces a rotation of the outer ring about A_1 . Then the axis of the gyroscope does not remain altogether horizontal.

An automatic correction device (not shown in the sketch) is set in motion when the angular distance between the gyro axis and the horizontal increases excessively. As a result, the air-blast tubes over the vanes in the rotor act dissymmetrically and the reaction of the current, dissymmetrical in its turn, sets up a couple which tends to restore the axis of the rotor to the horizontal.

4) The Smith gyrostabilizer.— Although a complete description of this instrument has been published in L'Aéronautique, No. 167, pp. 81-88, a comparison with others

based on the same principle, should be of interest.

The Smith gyroscope controls both the rudder and the elevator. The axis of the gyroscope is in the plane of symmetry of the airplane but is not exactly horizontal; it forms an angle of several degrees with the direction which is stipulated as being in normal flight the horizontal.

In the elementary sketch of figure 4, we assume the axis to be horizontal, leaving the explanation of why it has been tilted until later on. The gyroscope is driven by compressed air.

When the airplane begins to pitch, there is a relative movement between inner ring C_1 and the pivots A_1 . In order that ring C_1 shall respond to pitching motions only, the outer ring C_2 must always be normal to the plane of symmetry. When this condition is realized, the pitching can equally be detected by the movement of C_1 relative to any point of the frame or supports, which simplifies the design of the relays and of the servo controls.

The yawing motions produce a movement of the outer ring C_2 relative to the fixation frame. This movement controls the servo control.

The operating principle of the instrument is readily understood. Valves located at each ring and at the frame, control the inlet of the fluid to the servomotor. The liaison between the valve and the frame can be changed according to the control setting, in order to realize the servo control. However, satisfactory operation is contingent upon the gyro axis

- (1) being in the plane of symmetry
- (2) assuming, in this plane, the stipulated position.

In level flight, it is therefore necessary to prevent precession about A_1 and A_2 . In maneuvers, when it is desired to bank or change the flight-path slope of the airplane, it is necessary to acquire an angular movement of the rotor axle of the same amplitude in order that the gyroscope shall always maintain the same position with respect to the airplane.

The foregoing conditions are complied with in the following manner:

- (a) A regulating mechanism preserves the inclination of the axis of the gyroscope.

An eccentric weight T is fixed to ring C_2 . When the gyroscope is horizontal and the airplane flies level, the axis of the pivots is vertical and weight T sets up no couple.

When the gyroscope has precessed for any one reason about A_1 it becomes disturbed and inclines the flight path of the airplane. Under these conditions the axis OZ of the airplane and the supports A_2 do not remain vertical and weight T exerts about A_2 a couple which makes the axle of the gyro move backward toward its initial position. Then the flight path straightens out and becomes level again. The altitude adjustment of the gyro is thus obtained through the effect of flight-path changes.

Figure 4 is intended to demonstrate the principle, whereas the actual instrument is a little more complicated.

We find that, in the gravity, a directing effect always tends to guide the axis of the gyro in altitude, but not in azimuth. The gyroscope, unless automatic adjustment is possible, is subject to the previously cited causes of disorientation which, therefore, must be reduced to a minimum. One of these is the resistance of the elevator servo control which manifests itself as a couple about A_1 . It is absolutely necessary that this control exert as small a reaction as possible on C_1 , which led to the use of a relay without resistance for the altitude control, as already described.

There is one possibility - by means of a counter-weight modifying the couple about A_1 - of completing the adjustments and so of avoiding, in a large measure, the systematic precessions about axis A_2 . To effect directional changes, it is necessary to obtain a movement of the gyroscope, in azimuth, with an angular speed equal to that to be imposed on the airplane. To produce this movement requires only the application of a couple about axis A_1 , which the pilot achieves with the aid of a small compressed air cylinder; directional piloting is then possible with the stabilizer.

To change the slope of the airplane, it is necessary to obtain a movement of the gyroscope about A_1 ; this is accomplished by applying - through a Bowden cable - a permanent couple about axis A_2 . The gyroscope precesses and the flight path changes until the moment of the counterweight balances the applied couple. At that instant the slope of the flight path is constant. The stabilizer thus permits altitude piloting.

In reality, the axis of the gyroscope is, however, not horizontal but rather tilted through several degrees, the front being raised.

The purpose of this arrangement is to obtain a slight response to rolling motions. Every rotation p has, in this case, a component along the axis of the gyroscope and one along the axis of the pivots A_2 . In case of severe rolling, the rudder is actuated and this deflection may contribute to improve the lateral stability. However, this action is not altogether conclusive, seeing that the Smith company has in addition, supplemented its stabilizer by a second gyroscope controlling the ailerons.

5) Remarks. - (a) When using a gyroscopic stabilizer for the azimuth, it is imperative to apply corrections from time to time to the direction of the axis of the gyroscope by comparison with a magnetic compass.

This operation may be made automatic by a repeater compass. One obtains then a combination of two systems of detection of $\delta\psi$, which is capable of eliminating the disadvantages of both.

The addition of a Holmes telecompass of the electrolytic type, has already been described in this publication.

(b) Table IV shows that almost everyone of the designers makes use of course stabilization.

The use of azimuth stabilizers is so largely justified for theoretical reasons that we well believe this principle to be convincing and that all future stabilizers will incorporate an element responsive to disturbances $\delta\psi$.

19. Aileron Control According to Lateral Inclination ϕ

Elsewhere it has been shown that a third type of instrument controls the ailerons in function of the lateral inclination. These instruments are necessarily gyroscopic. Those making use of pendulums sensitive to the apparent gravity, are excluded and appear in the fourth group. The two stabilizers of the third type, described hereinafter, are for airplane use only in combination with appropriate course stabilizers.

THE SPERRY INSTRUMENT

The Sperry uses a gyroscope with vertical axis to control both the elevators and the ailerons.

The sketch (fig. 3) is self-explanatory. The control mechanism, by pressure capsule, is the same as for the directional stabilizer described before.

When the pilot wants to bank he fixes the lateral inclination by shifting the position of the blast tubes in front of the valve organism by means of a knob G which actuates the servo control.

The pilot thus selects the lateral inclination at which he wishes to bank; he determines the angular rate of rotation by the rapidity with which he handles the banking knob E. In this manner, correct inclination is dependent on his skill and not on the stabilizer.

As regards the longitudinal slope, the pilot controls his flight-path angle with a knob H which moves the inlet of the elevator control tubes.

The Sperry stabilizer demands unrestrictedly that the axis of the gyroscope remain horizontal. To this end, an ingenious arrangement subordinates the gyroscope to the gravity which tends to return the rotor axle to the vertical.

The device is dependent on the apparent gravity. However, it takes effect so slowly that it stabilizes the axis of the gyroscope along a mean of the apparent gravities which, in the final count, should differ little from the vertical.

The gyroscope is integral with four small pendulums disposed in a way as to be able to close the vents through which the air is aspirated from the cage containing the rotor.

The quadruple pendular valve, placed beneath the gyroscope, is shown in figure 5. A is one of the pendulums. For the sketched inclination, A uncovers one of the vents B completely, while the symmetrical pendulum closes the corresponding vent completely. The reactions caused by the difference in air pressure are not alike and set up a couple C which, by precession, returns the gyroscope to its normal position. This device keeps the axis at least 1° from the vertical, according to the designer.

THE SMITH STABILIZER (Fig. 7)

The lateral stabilizer (fig. 6) consists of a gyroscope whose axis of rotation is parallel to the transverse axis OY.

The gyroscope is carried on two gimbal rings B and F.

The small plate shown in figure 8 is invariably placed on the outer frame F. The gyro axis remaining horizontal, the rolling motions are translated by movements of the outer ring relative to its supports, say of the piece Q, for example. These movements actuate the valve (not shown) of the aileron servomotor control. The link of this piston valve is attached to the outer ring F; the cylinder is fastened to a frame Q, which itself can move on horizontal pivots when the ailerons are deflected, thus establishing the servomotor control.

Another valve is visible at C. When ring B moves with respect to ring F and to the plate integral with it, valve C starts to operate: It admits compressed air to cylinder D, which causes the system to precess about the pivots of the outer ring F. A light spring E actuates the link of valve C. Lastly, a weight A is located under the outer ring F. This arrangement is to satisfy the following: in level flight, to oppose movements of the gyro axis in the horizontal as in the transverse plane; in banking, to force the gyroscope to precess about the vertical pivots at an angular velocity equal to that of the bank.

Assume the axis of the gyroscope, moving in the horizontal plane, is no longer parallel with axis OY . This requires ring B to move about the vertical pivots. The inner ring ceases to be normal to ring F and valve C becomes operative. It applies through the medium of pump barrel D a couple acting on ring F about the horizontal pivots, which forces B to precess and to regain its initial position.

When the axis of the gyroscope moves in a vertical plane about the horizontal pivots, the effect of weight A on these pivots is a couple which makes the gyroscope precess about the vertical axis. This motion acts on valve C which starts D on its way to apply about the horizontal pivots a couple opposite to that exerted by weight A about axis A_2 . The spring E finally returns the inner ring to its normal position, the weight A being vertical.

Thus, when the axis of the gyroscope is diverted from the direction OY , it tends to return to it. Stability is accordingly assured.

Now let us study the effect of a change of heading. If the airplane executes a flat bank, the centrifugal force acts on the weight A and changes the direction of the apparent gravity. A couple acts on the outer pivots and makes ring B and the gyroscope precess about the inner pivots.

This precession is in the direction of the bank and, for a predetermined airplane speed, the plane of the rotor keeps pointing in the plane of symmetry of the airplane.

This speed depends on the stabilizer characteristics only. Let

I be the moment of inertia of the rotor

ω , speed of rotor

m , mass of weight A

d , its lever arm

r' , rate of precession

r , rate of turn of airplane

R, radius of turn

V, airplane speed

The rate of precession r' follows from

$$I \omega r' = m r^2 R d$$

Accordingly, r' is equal to r when

$$r R = \frac{I \omega}{m d}$$

or when

$$V = \frac{I \omega}{m d}$$

The movement of the gyroscope is obtained only for the flat bank. If the airplane takes the correct lateral inclination, weight A exerts no couple about the pivots; the gyroscope does not precess nor follow the airplane.

These two kinds of instruments have been described in order to show all the advantage that may be drawn from the gyroscope.

However, it seems that the various solutions described above do not meet all the requirements which may be made, since they do not allow, in case of a controlled turn, for giving the airplane the correct lateral inclination automatically.

20. Theoretical Study

The same mathematical theory which reveals the rate of return to the normal flight path in the case of automatic piloting, defined by

$$\gamma = k \delta \psi$$

allows us equally to study the rate and the damping of the disturbances when the automatic piloting attains to

$$\gamma = k \delta \psi + k' \delta r$$

or, when it realizes $\gamma = k \delta \psi$

$$\alpha = k'' \delta \varphi$$

Garner, who analyzed these two types of control in his report (R. & M. No. 1077 (reference 2, N.A.C.A. Technical Memorandum No. 802)), has shown that the latter type of control, using rudder and ailerons together, appeared to be the best from the point of view of rapidity of damping of the disturbances - a fact not difficult to understand. We showed at the beginning of the report that the disturbances in lateral inclination, inevitably followed by sideslip, sustain the yawing motion; the latter is thus effectively combatted by reacting against the rolling.

21. Lateral Pendulums

As for the longitudinal stability, the apparent gravity is the result of gravitation and of the inertia forces acting on the masses.

Visualize a pendulum mounted in an airplane and free to move in the plane ZOY (fig. 9), φ' being the angle formed by the pendulum and the extension of the axis of Z. This angle is positive when the pendulum swings to the right.

If the airplane, aside from its swing of φ , turns or experiences an acceleration with respect to axis OY, the position φ' of the pendulum corresponds to

$$\varphi' = \varphi + \frac{1}{g} \left(\frac{dv}{dt} + rV \right)$$

$\frac{dv}{dt}$ being the acceleration along axis OY fixed in the airplane, and rV the centrifugal acceleration.

A number of designers of stabilizers have wished to utilize the reference apparent gravity and have built pendular devices. It is essential to make the pendulums aperiodic by appropriate damping, but the critical damping must not be exceeded, so as not to make the pendulums sluggish.

The advantage of the reference apparent gravity is to be, it seems, the only one which permits of obtaining the correct inclination automatically in a bank.

The readers of L'Aéronautique are familiar with the apparatus described by Gianoli. Others, combining the

apparent gravity with another reference are: the Mazade Aveline, utilizing the rate of turn r ; the S.E.C.A.T., using the angle of sideslip j according to an old patent, and speed r according to a more recent patent; Siemens, which utilizes the rate of roll p .

THE MAZADE APPARATUS

This instrument (fig. 10) dates back to 1923. The designer operated the two controls (ailerons and rudder) by combining the readings of pendulums and bank indicators, but without utilizing the azimuth reference which, we believe, was a fundamental mistake, and it was a waste of effort to try to stabilize the motion of an airplane by the means employed.

Still, it presented some noteworthy features. The lateral stabilizer comprised a U-shaped tube containing mercury located in the plane ZOY. The top of each of these tubes communicated with a venturi mounted at the opposite wing tip. Contacts fitted above the mercury actuate the ailerons as soon as the level in one or the other column rises, the aileron on the side of the rising mercury column being deflected downward. When the ailerons are deflected, a servo control moves the tubes in the same sense as the mercury, so as to break the contact at the moment when the law of the desired deflection is realized. Baffles in the tube damp the mercury movements.

The plane passing through the mercury level in the tubes is that of the apparent horizontal. In banking the apparatus should take the theoretical inclination if the negative pressure tubes did not happen to lower this difference of level. Then the venturi tubes diminish the centrifugal force effect. Once the apparatus is inclined, the stabilizer acts in the opposite fashion when the necessity arises of sustaining the airplane as a pilot does.

This apparatus has given some interesting results. The designer wanted to overcome getting off of the course, occasioned by the lateral disturbances, with a second apparatus of the same kind, but then the effect of the centrifugal force was reduced with respect to the differences in pressure. For this purpose the two vertical arms of the U were brought together. We do not believe that this part of the device was of a nature to give satisfaction.

It may also be added that the servo control here was not made by movement of the tube but by opening of valves in the air line.

THE S.E.C.A.T. APPARATUS

The aileron control of this instrument is realized in the following manner. An old S.E.C.A.T. patent describes a stabilizer comprising a pendulum swinging about an axis parallel to direction OX, and whose link carries a paddle orientated along the plane of symmetry and subject to a reaction in case of sideslip (fig. 11).

A more recent scheme describes a pendular stabilizer where the effect of the linear speed difference is added to the indication of the pendulum moving in plane ZOY (fig. 12).

The operating method is similar to that of the altitude stabilizer shown in figure 8. Two pressure plates mounted at the wing tips, control the rocker arms of the pinions; their effect is added to that of the pendulum through pinions and movable sectors.

In a right bank the pendulum moves leftward, engaging the brush toward the right. The left pressure plate is subjected to a greater pressure than that on the right; the levers and sectors move as shown by the arrows. The sector carrying the contact pieces moves to the right in the same sense as the brush, which implies that the effect of the difference of the lateral speeds is restricted to the effect of the pendulum.

It is exactly the same combination as that of the Mazade-Aveline stabilizer, only obtained by different means.

THE SIEMENS APPARATUS

In the Siemens the aileron control is obtained with a pendulum and a rate of roll indicator gyroscope. The stabilization is achieved in function of

$$\varphi + \frac{1}{g} \left(\frac{d\dot{\nu}}{dt} + rV \right)$$

and of $\frac{d\phi}{dt}$. The gyroscope is responsive to the derivative of a part of the disturbance acting on the pendulum.

The sketch of the underlying principle (fig. 13) explains its operating method. The Siemens stabilizer allows automatic control of banking; it should provide the correct lateral inclination.

Piloting by the Siemens apparatus is unlike that which the pilot does when flying according to the readings of his flight controller, but it displays sound judgment. A Junkers airplane fitted with a Siemens stabilizer has, in fact, made numerous automatic flight demonstrations.

22. Remarks and Conclusions

In this protracted study, we have laid more stress on the principles underlying automatic piloting than on the means of applications. We did not describe the mechanical details of servomotors nor the details of the mechanical release devices necessary to assure instantaneous return of the controls to the pilot in case of malfunctioning of the stabilizer. As a general rule, the controls by oil or air pressure are preferred to the electric control. The use of electric motors controlled directly by disturbance detectors, is not possible because of the inertia of the motors.

As regards the controls by oil pressure, it is always possible to supplement the quick release mechanism by an additional safeguard - by the simple expedient of putting the two faces of the servomotor piston in communication by a bypass, to enable the pilot, operating the conventional airplane controls, to overcome the reaction of the servomotor quite easily.

The descriptions of commercial order, published heretofore are, in general, quite profuse in details concerning the weight of equipment, pressures, and supply of oil pumps or air compressors.

We have attempted to explain the psychology of the different disturbance detectors and to show how the peculiarities of their character might be utilized in accord with the dynamics of the airplane, with a view to improv-

ing the flight path of an airplane flying hands off.

We believe, however, that the study of the stabilizer cannot be separated from the study of the reactions of the airplane itself. Although having been unable to treat the problem in its details, particularly as regards the reactions of the lateral control for different airplane types (with or without great secondary effect), it is hoped that we have succeeded in drawing attention to the importance attaching to the adaptation of the stabilizer to the airplane.

Translation by J. Vanier,
National Advisory Committee
for Aeronautics.

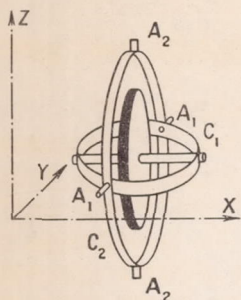

Figure 1.- Principle of directional gyroscope.

Figure 2.- S.E.C.A.T. gyroscopic rudder control.

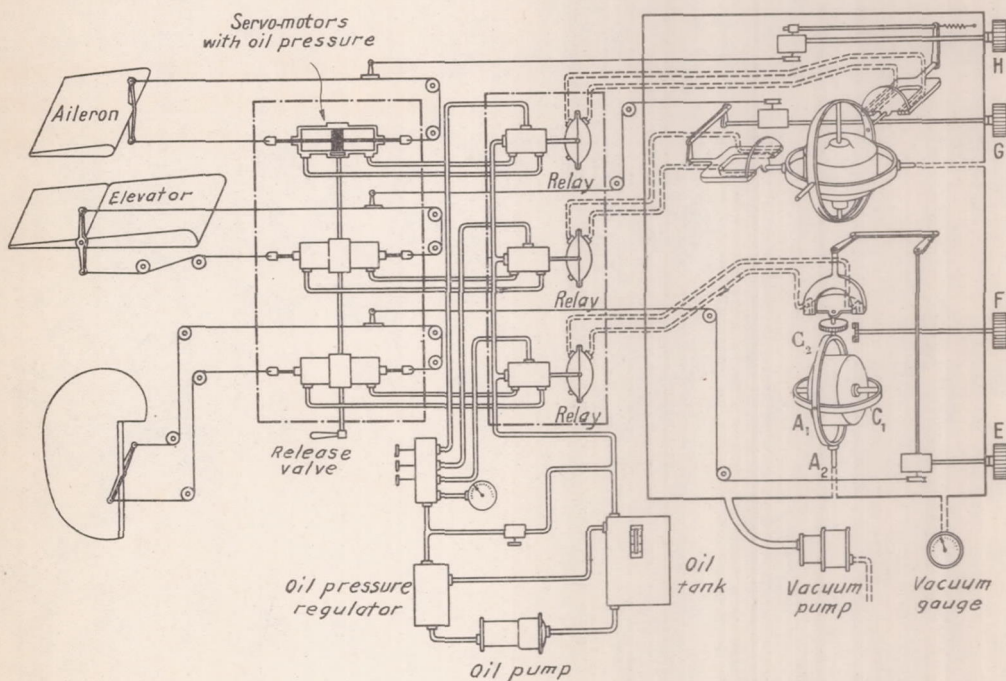
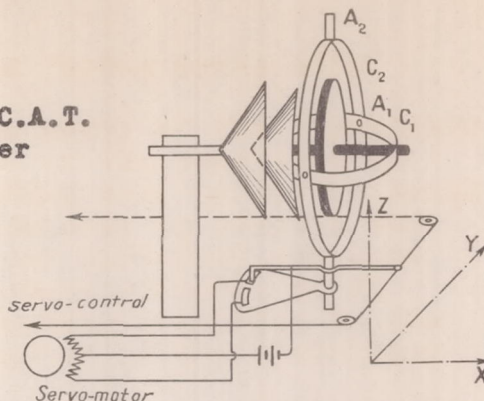

Figure 3.- Assembly sketch of Sperry stabilizer.
H, climbing knob; G, banking knob.
(For other references see text).

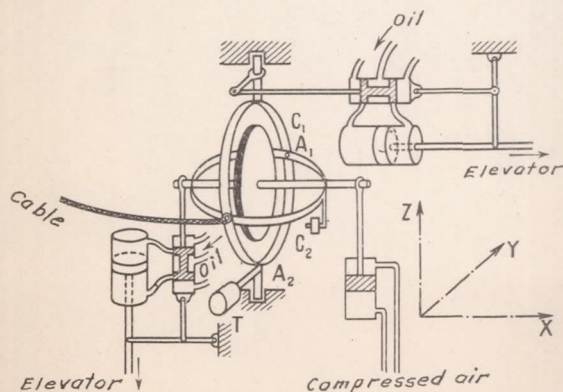

Figure 4.- Smith rudder and elevator control.

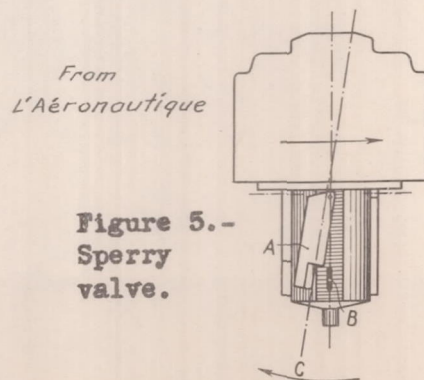

Figure 5.- Sperry valve.

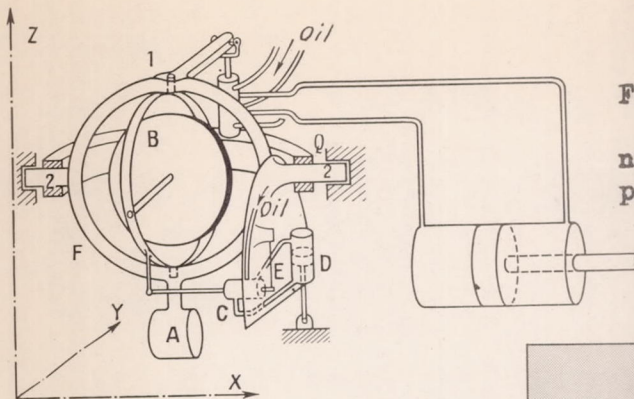
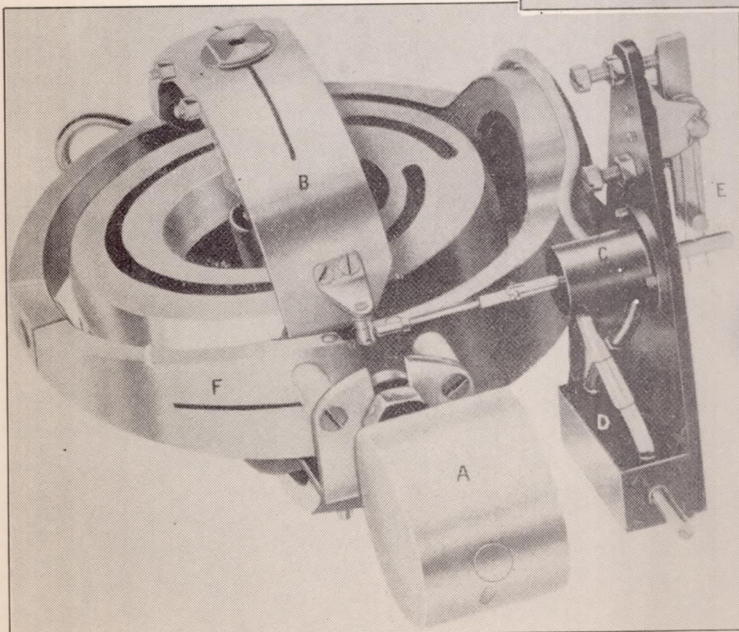
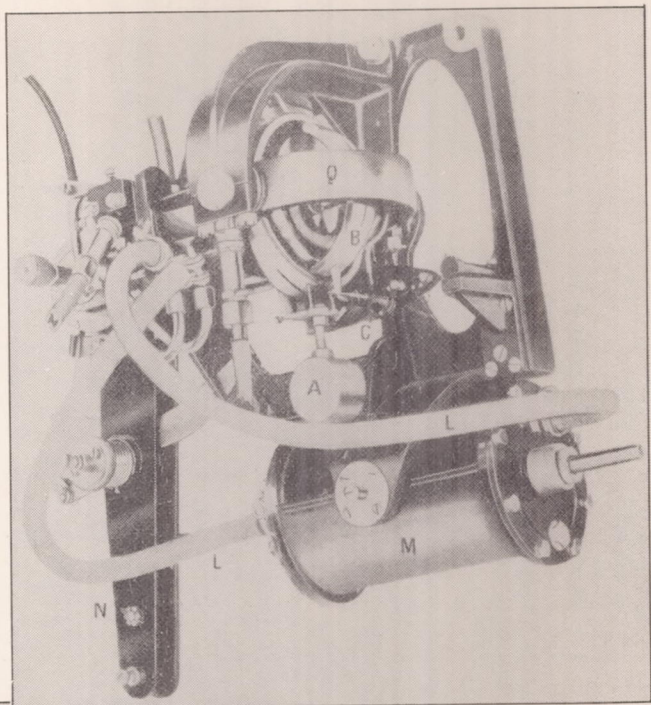

Figure 6.- Sketch of aileron control in the new Smith stabilizer (1,vertical pivots;2,horizontal pivots).

Figure 7.- Smith aileron control.



From L'Aéronautique

Figure 8.- Details of central portion of figure 22.

