

NHB 7320.2
JANUARY 1972
EDITION

7N-31
191251
92P

LABORATORY and INDUSTRIAL VENTILATION

(NHB-7320.2) LABORATORY AND
INDUSTRIAL VENTILATION (NASA)
92 p

N94-70549

Unclass

29/31 0191251



**NATIONAL AERONAUTICS AND SPACE ADMINISTRATION
WASHINGTON, D. C. 20546**

For sale by the Superintendent of Documents, U.S. Government Printing Office, Washington, D.C. 20402

PREFACE

January 1972

This handbook supplements the Facilities Engineering Handbook (NHB 7320.1) and provides additional policies and criteria for uniform application to ventilation systems. It expands basic requirements, provides additional design and construction guidance, and places emphasis on those design considerations which will provide for greater effectiveness in the use of these systems.

The provisions of this handbook are applicable to all NASA field installations and the Jet Propulsion Laboratory. Since supply of this handbook is limited, abstracts of the portion or portions applicable to a given requirement will be made for the individual specific needs encountered rather than supplying copies of the handbook as has been past practice.

Suggestions concerning the criteria of this handbook are encouraged whenever additional information supporting such suggestions becomes available based on experience. Therefore, NASA installations are encouraged to forward recommendations for suggested changes to this handbook to the Office of Facilities (Code BX) NASA Headquarters. Such recommendations will be considered for revisions in later editions of this handbook.

Initial internal distribution has been made to all NASA installations. The public may obtain copies of this handbook from the Superintendent of Documents, Government Printing Office, Washington, D. C. 20402.



R. H. Curtin
Director of Facilities

DISTRIBUTION
SDL 1 (SIQ)



LABORATORY AND INDUSTRIAL VENTILATION

INDEX FINDER

CHAPTER	1:	GENERAL	1
	2:	ENVIRONMENTAL HEALTH AND SAFETY	2
	3:	SYSTEMS	3
	4:	HOODS AND EQUIPMENT	4
	5:	APPLICATIONS	5
	6:	DESIGN	6
	7:	ALTERATIONS	7
	8:	OPERATIONS AND MAINTENANCE	8
	9:	A METHOD OF SYSTEM BALANCING	9
	10:	TESTING INSTRUMENTS	10

100
100
100
100

CHAPTER 1: GENERAL

TABLE OF CONTENTS

Paragraph		Page
101	INTRODUCTION	1-1
102	OBJECTIVE	1-1
103	SCOPE	1-1
104	APPLICABILITY	1-1
105	SYSTEM AUTHORIZATION	1-1
106	REFERENCES AND BIBLIOGRAPHY	1-2
107	DEFINITIONS	1-4



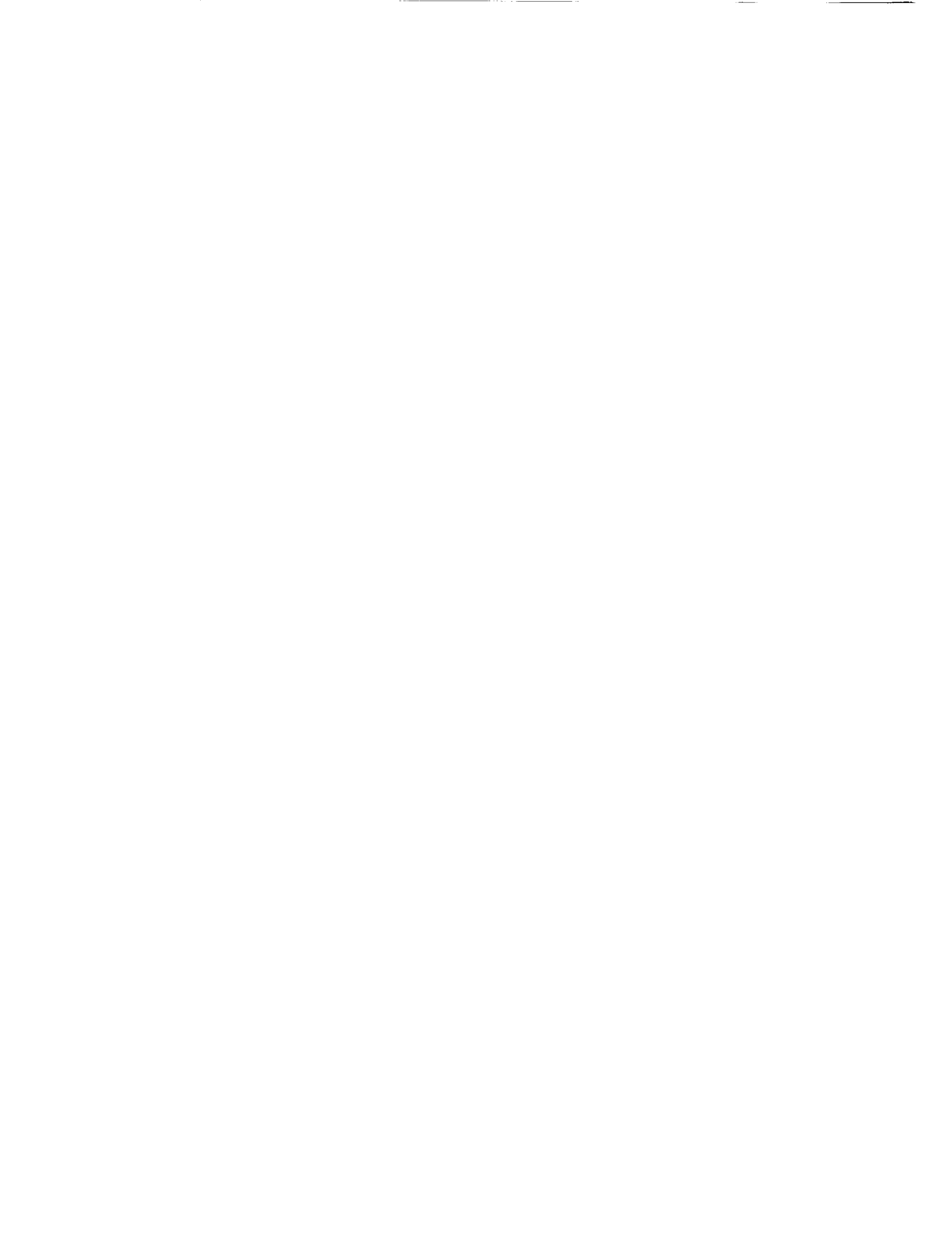

CHAPTER 1: GENERAL

101 INTRODUCTION

This handbook is intended as a guide to assist all NASA facilities in planning, obtaining, maintaining and operating safe and efficient industrial and laboratory ventilation systems. Current practices and recommendations of recognized organizations form the basis for the principles and data contained herein.

102 OBJECTIVE

The objective of this manual is to fill an information gap and to promote better understanding of industrial and laboratory ventilation by the scientist, the designer, the user and the plant engineer. Better understanding by all concerned, of each other's problems, will result in planning, obtaining, maintaining, and operating safer and more efficient facilities.

103 SCOPE

This manual contains information pertaining to industrial and laboratory ventilating systems for removal of fumes, vapors, dusts, and excessive heat which cause hazards or discomforts. No attempt has been made to include heating, ventilation or air-conditioning to maintain comfort conditions. Information on these systems can be found in other technical publications. The information presented herein is intended as a guide for planning and operating industrial and laboratory ventilation systems. Various recommendations are contained herein as well as discussions and warnings pertaining to some problem areas. No attempt has been made to include all the technical data or detailed information required for designing systems. Instead the information contained is intended to guide and promote thought in planning, operating and maintaining these systems.

104 APPLICABILITY

The provisions of this manual generally apply to other than program-oriented special-purpose facilities as outlined in NASA Handbook NHB 7320.1 "Facilities Engineering Handbook," Chapter 1, paragraph 104. However applicable components of special purpose facilities do fall within the provisions. The manual applies to: Government-owned and operated facilities; Government-owned and contractor-operated facilities; other facilities provided by NASA resources and those to be built or placed by others on NASA-controlled real estate. The manual applies in the contiguous United States and outside thereof to the extent practicable. It will apply to other-than-permanent facilities to the extent indicated in applicable project approval documentation. It is not the intent of this manual to require that existing facilities be made to conform to the criteria set forth. However, if the non-conforming conditions of existing facilities are directly and significantly related to proposed new construction, addition or alteration work, they should be corrected as a part of the newly proposed work. The manual shall also be realistically applied, to the extent practical, to facilities work proposed under field installations, maintenance and repair programs or projects and their operation.

105 SYSTEM AUTHORIZATION

There is a tendency among using personnel to attempt to improve their individual zone of occupancy by altering installed ventilation systems. Each facility should establish and implement the necessary procedures to police and inspect ventilation systems to prevent unauthorized modifications. A single agency, office or department should be given the responsibility of reviewing the alteration of all ventilating systems of that facility. Without control of ventilation systems a facility invites a hazardous condition.

106 REFERENCES AND BIBLIOGRAPHY**1. U.S. GOVERNMENT PUBLICATIONS****a. DEPARTMENT OF DEFENSE****Military Standard**

MIL-STD-282 Filter Units, Protective Clothing Gas Mask Components and Related Products, Performance Test Methods

b. GENERAL SERVICES ADMINISTRATION**Federal Standard**

No. 209 Clean Room and Work Station Requirements, Controlled Environment

Federal Register

Vol. 36, No. 105, Part II Occupational Safety and Health Administration, Department of Labor

c. NATIONAL AERONAUTICS AND SPACE ADMINISTRATION**Handbook**

NHB 7320.1 Facilities Engineering Handbook

Handbook Supplement

Proposed Identification of Utility Systems

d. OAK RIDGE NATIONAL LABORATORY

Oak Ridge, Tennessee

(Publications are available from U.S. Department of Commerce, National Bureau of Standards, Springfield, Virginia 22151)

Publication

Design, Construction, and Testing of High Efficiency Air Filtration Systems for Nuclear Application

e. UNITED STATES AIR FORCE**Technical Order**

00-25-203 Standards and Guidelines for the Design and Operation of Clean Rooms and Clean Work Stations

2. NON-GOVERNMENT PUBLICATIONS

- a. **American Conference of Governmental Industrial Hygienists**
Committee on Industrial Ventilation
Box 453, Lansing, Michigan 48902

Industrial Ventilation
- b. **American Society of Heating, Refrigerating and Air-Conditioning Engineers, Inc. (ASHRAE)**
Circulation Sales Department, United Engineering Center
345 East 47th Street, New York, New York 10017

ASHRAE Guide and Data Book, Applications

ASHRAE Guide and Data Book, Equipment

ASHRAE Guide and Data Book, Systems

ASHRAE Handbook of Fundamentals
- c. **Associated Air Balance Council (AABC)**
2146 Sunset Boulevard, Los Angeles, California 90026

National Standards for Field Measurements and Instrumentation – Total System
Balance
- d. **Chemical Rubber Company**
18901 Cranwood Parkway, Cleveland, Ohio 44128

Handbook of Laboratory Safety
- e. **McGraw-Hill Book Company, Inc.**
New York, New York

Marks' Mechanical Engineers' Handbook
- f. **National Fire Protection Association (NFPA)**
Publications Department
60 Batterymarch Street, Boston, Massachusetts 02110

No. 33 Spray Finishing Using Flammable and Combustible Materials

No. 70 National Electrical Code

No. 91 Blower and Exhaust Systems

No. 96 Removal of Smoke and Grease-Laden Vapors from Commercial Cooking
Equipment

- g. National Safety Council**
425 N. Michigan Ave., Chicago, Illinois 60611
Data Sheet 246 (1952) Storage Batteries
- h. Sandia Corporation**
Post Office Box 5800, Albuquerque, New Mexico 87116
Paper: Basic Design Requirements for Laminar Air Flow Dust Control Devices
Manual: Operating Manual for the Sandia Clean Bench
- i. Sheet Metal and Air Conditioning Contractors National Association, Inc. (SMACNA)**
1611 North Kent Street, Suite 200, Arlington, Virginia 22209
Manual for Balancing and Adjustment of Air Distribution Systems

107 DEFINITIONS

aerosol: An assemblage of small particles, solid or liquid, suspended in air. The diameter of the particles may vary from 100 microns down to 0.01 micron or less, e.g., dust, fog, smoke.

air cleaning equipment: Devices designed for the purpose of removing atmospheric airborne impurities such as dust, gases, fumes, smoke, chips and vapors from the air.

air, standard: Dry air at 70°F and 29.92 in. (Hg) barometer. This is substantially equivalent to 0.075 lbs per cu. ft. (For more detailed data see Chapter 30 of ASHRAE Handbook of Fundamentals.)

blast gate: Sliding damper.

capture velocity: The air velocity at any point in front of the hood or at the hood opening necessary to overcome opposing air currents and to capture the contaminated air at that point by causing it to flow into the hood.

clean room: A specially constructed enclosed area environmentally controlled with respect to airborne particulates, temperature, humidity, air pressure, air flow patterns, air motion and lighting.

clean work area: A portable clean room or clean bench with a direct air supply and more flexible use than a clean room.

density: The ratio of the mass of a specimen of a substance to the volume of the specimen. The mass of a unit volume of substance. When weight can be used without confusion, as synonymous with mass, density is the weight of a unit volume of substance.

dilution ventilation: The dilution of contaminated air with uncontaminated air in a general area, room or building for the purpose of reducing health hazards or nuisances.

dust: Small solid particles created by the breaking up of larger particles by processes such as crushing, grinding, drilling, explosions, etc. Dust particles already in existence in a mixture of materials may escape into the air through such operations as shoveling, conveying, screening, sweeping, etc.

face velocity: The velocity of air as it passes through the plane of an opening.

filter: Filters for air are devices for removing airborne particulate contaminants such as dusts from the air.

fumes: Small solid particles formed by the condensation of vapors of solid materials.

gases: Formless fluids which tend to expand to occupy an entire space uniformly at ordinary temperatures and pressures.

gravity, specific: The ratio of the mass of a unit volume of a substance to the mass of the same volume of a standard substance at a standard temperature. Water at 39.2°F is the standard substance usually used for reference. For gases, dry air, at the same temperature and pressure as the gas, is often taken as the standard substance.

hood: A shaped inlet designed to capture contaminated air and conduct it into the exhaust duct system.

inch of water: A unit of pressure equal to the pressure exerted by a column of liquid water one inch high at a standard temperature.

laminar flow: Air flow in parallel flow lines with uniform velocity and minimum eddies.

latent heat: Heat absorbed or dissipated during a change in state in which there is no change in temperature.

lower explosive limit (LEL): The lower limit of flammability or explosibility of a gas or vapor at ordinary ambient temperatures expressed in percent of the gas or vapor in air by volume. This limit is assumed constant for temperatures up to 250°F. Above these temperatures, it should be decreased by a factor of 0.7 since explosibility increases with higher temperatures.

micron: A unit of length, the thousandth part of 1 millimeter or the millionth of a meter, (approximately 1/25,400 of an inch).

mist: Small droplets of materials that are ordinarily liquid at normal temperature and pressure.

particle size: The maximum linear dimension or diameter of a particle.

pressure, atmospheric: The pressure due to the weight of the atmosphere. Standard atmospheric pressure is 29.92 inches of mercury.

pressure, static: The potential pressure exerted in all directions by a fluid at rest. For fluid in motion it is measured in a direction normal to the direction of flow. Usually expressed in inches of water gage when dealing with air.

pressure, total: The algebraic sum of the velocity pressure and the static pressure (with due regard to sign).

pressure, vapor: The pressure exerted by a vapor. If a vapor is kept in confinement over its liquid so that the vapor can accumulate above the liquid, the temperature being held constant, the vapor pressure approaches a fixed limit called the maximum or saturated, vapor pressure, dependent only upon the temperature and the liquid.

pressure, velocity: The kinetic pressure in the direction of flow necessary to cause a fluid at rest to flow at a given velocity.

radiation, thermal (heat) radiation: The transmission of energy by means of electromagnetic waves of very long wave length. Radiant energy of any wave length may, when absorbed, become thermal energy and result in an increase in the temperature of the absorbing body.

sensible heat: That heat which will directly effect temperature.

slot velocity: Linear flow rate of air through a slot, feet per minute (f.p.m.).

smoke: An air suspension (aerosol) of particles, usually but not necessarily solid, often originating in a solid nucleus, formed from combustion or sublimation.

temperature, effective: An arbitrary index which combines into a single value the effect of temperature, humidity and air movement on the sensation of warmth or cold felt by the human

body. The numerical value is that of the temperature of still, saturated air which would induce an identical sensation.

temperature, wet bulb: Thermodynamic wet-bulb temperature is the temperature at which liquid or solid water, by evaporating into air, can bring the air to saturation adiabatically at the same temperature. Wet-bulb temperature is the temperature indicated by a wet-bulb psychrometer.

threshold limit values (TLV): The values for airborne toxic materials which are to be used as guides in the control of health hazards and

represent time weighted concentrations to which nearly all workers may be exposed 8 hours per day over extended periods of time without adverse effects.

transport (conveying) velocity: Minimum air velocity required to move the particulates in the the air stream.

vapor: The gaseous form of substances which are normally in the solid or liquid state and which can be changed to these states either by increasing the pressure or decreasing the temperature. Vapors diffuse.

CHAPTER 2: ENVIRONMENTAL HEALTH AND SAFETY

TABLE OF CONTENTS

Paragraph		Page
201	ROLE OF THE ENVIRONMENTAL HEALTH AND SAFETY PERSONNEL	2-1
202	COMMON HAZARDS	2-1
1.	Makeup Air	2-1
2.	Improper Face Velocities	2-1
3.	Excessive Equipment in Hood	2-2
4.	Unauthorized Use of Systems	2-2
5.	Unauthorized Systems	2-2
6.	Improper Maintenance	2-2
7.	Condensation	2-2
8.	Disposal of Waste	2-2
9.	Locations of Intakes and Exhausts	2-2
10.	Open Windows and Doors	2-2
11.	Ventilation System Fires	2-2
12.	Short Circuiting of Air	2-2
13.	Location and Space for Maintenance	2-3
14.	Guarding of Moving Parts	2-3
15.	Drafts	2-3





CHAPTER 2: ENVIRONMENTAL HEALTH AND SAFETY

201 ROLE OF THE ENVIRONMENTAL HEALTH AND SAFETY PERSONNEL

Laboratory and industrial ventilation systems are provided in facilities for the purpose of reducing hazards. These hazards may be to personnel working in the vicinity of a process, to equipment installed in the facility, or to the outside environment. Hazards may include those caused by toxic or noxious fumes, vapors, dusts, smokes, radioactive elements, explosive materials, and flammable materials. The ventilation system should be designed and operated in a manner to transport and to remove these hazardous materials and dispose of them in a safe and efficient manner. In the modern facilities used today it is likely that two or more processes will take place within the same facility, each being nonhazardous or only mildly hazardous within itself. However, gases, fumes, vapors, dusts, smokes, or other emissions from one process may become highly dangerous when mixed with those of the other processes. Some materials are not considered as hazardous until a given concentration is reached. Other materials present hazards only after personnel have been exposed to them for prolonged periods of time. Still other materials are hazards only in the sense that they cause minor discomforts. The sources and combinations of these hazardous materials are endless. Generally the engineers responsible for design, operation or maintenance of ventilation systems are trained to think in terms of hood design to obtain a selected face velocity, fan selection, drive selection, duct sizing and construction, maintenance of motors and drives, and other related factors. The recognition of potential hazards due to use of hoods, equipment or inadvertent mixing of elements from separate operations is not likely. On the other hand environmental health and safety personnel are trained to think in terms of unusual, unlikely and inadvertent incidents which could cause mishaps or hazards. They are familiar with factors such as chemical reactions, radioactive phenomena, and reactions of the human body to various elements. These specialists can recognize potential hazards and in most cases can advise the engineer as to the corrective action necessary. Neither of these two specialized groups can, by themselves, effectively cope with ventilation problems of this nature.

Together, these two specialist groups form a team which is effective and efficient. It is incumbent upon the Design Engineer to seek the services of environmental health and safety personnel to determine the necessary face velocities, capture velocities, threshold limit values (TLV), lower explosive limits, compatibility of systems, types of hoods and systems to be used, methods of disposal of waste materials, fire protection considerations, etc. Many times it will be necessary to consult those who formulated the criteria and are familiar with the type of activity to be conducted in the facility. The engineer who has the responsibility for proper operation and maintenance of systems should seek the services of environmental health and safety personnel to aid in the periodic and systematic testing of hoods and systems for proper operation. These tests or checks should also include policing of activities being conducted to insure that the system is being used for a purpose that is within the systems capability. Together these specialists should formulate and police procedures for removal of waste material from separators or filters and the disposal of this waste. These procedures should include disposal of contaminated water. Protection should be provided for the environment as well as the personnel engaged in handling the material.

202 COMMON HAZARDS

1. Makeup Air. A common deficiency found in laboratory and industrial ventilation is insufficient makeup air. This causes undesirable air currents within a building and undesirable low pressure areas. As a result, inadvertent mixing of fumes constitutes a hazard. Also, reduced performance of equipment can cause low hood face velocities and capture velocities or reduced dilution rates.

2. Improper Face Velocities. Systems providing excessively low hood face velocities allow escape of gases, fumes, vapors and dusts, thus exposing personnel and adjacent equipment to possible hazards. When face velocities are too high, eddy currents may be developed within or in the vicinity of the hood. These currents can cause escape of gases, fumes, vapors or dusts and can be detrimental to the process being conducted. High

face velocities also require excessive exhaust air which can tax the makeup air system and cause undesirable air currents.

3. Excessive Equipment In Hood. Laboratory hoods are often wrongly used as storage for equipment. Excessive equipment stored or excessively large equipment used within a hood will change the air flow patterns. Low face velocities can exist over a portion of the hood while high face velocities exist over another portion. Hoods should not be used for storage purposes.

4. Unauthorized Use of Systems. A given system has its limitations. Too often a system is used for a purpose for which it was not intended. This practice can be extremely dangerous. Ventilation rates, or velocities may not be sufficient for the new process. Exhaust materials may damage the equipment due to corrosion. Explosive conditions may occur, or reactive materials may cause a fire in the system. Radioactive materials may not be properly shielded. Improper separation or filtering equipment may allow pollution of the environment. Hazardous waste material collected by a filter or separator not intended to collect such material may cause injury to maintenance personnel when they service the filter or separator.

5. Unauthorized Systems. Unauthorized ventilation equipment is frequently found in laboratory type facilities. Unauthorized equipment is that equipment installed and used but not coordinated and checked out with those persons responsible for operation and maintenance of ventilation systems. This equipment is usually obtained and installed by personnel working within an area in an effort to improve their immediate area of occupancy. Such items as fans, additional duct outlets, additional ducts, damper setting changes, blocked off duct outlets, etc. will alter the complete system.

6. Improper Maintenance. This item can result in many hazards. Improper wash down or clean-up by using personnel can result in hazardous conditions and shortened life of equipment.

7. Condensation. Acid vapors condense in ductwork under certain conditions. The acid thus formed may corrode the ductwork, leak out and cause damage to the building as well as being hazardous to personnel.

8. Disposal of Waste. Extreme care must be taken in working out procedures for removal of filters or cleaning of separators in systems handling hazardous material. Not only do the servicing personnel need protection, but care must be taken to collect material which may fall off filters thus contaminating either the system or the area around the system. Proper disposal of the waste including contaminated water, must be planned and carried out.

9. Locations of Intakes and Exhausts. Exhausts often discharge in a manner to damage nearby structures. Also, wind currents may cause exhaust fumes or vapors to be carried back into intakes.

10. Open Windows and Doors. Modern ventilation systems are designed to operate with the exterior windows and doors shut. The opening of windows, or of doors for other than normal passage, will upset the planned air flow patterns, room pressure differentials, temperatures and humidities. An opening of this type precludes the maintenance of negative or positive pressures within the building and allows wind pressures (either high or low) to act upon the air flow patterns inside the building.

11. Ventilation System Fires. Fires in exhaust systems constitute one of the most common hazards in ventilation systems. Fire protection in the form of extinguishing systems (automatic or manual) or fire detection and alarm systems should be provided where this type of hazard is possible. Provisions should be made to allow cleaning of ductwork where grease or other combustible materials are likely to collect. Procedures for cleaning should also be developed and enforced.

12. Short Circuiting of Air. Short circuiting may occur where several hoods or exhaust outlets

are located in the same area. This hazard can be eliminated by providing proper makeup air and system balancing.

13. Location and Space for Maintenance. Improper consideration of location of equipment and accessibility for maintenance endanger maintenance personnel and cause poor maintenance of facilities.

14. Guarding of Moving Parts. Lack of proper guards for rotating or moving parts of machinery creates a hazard for maintenance personnel.

15. Drafts. Improper room air patterns and velocities may cause the escape of gases, fumes, vapors or dusts from hoods.



CHAPTER 3: SYSTEMS

TABLE OF CONTENTS

Paragraph	Page
301 SYSTEMS APPROACH TO VENTILATION	3-1
1. Consider Building as a Whole	3-1
2. Makeup and Exhaust Air Balance	3-1
3. Air Flow Patterns	3-1
4. Mixing of Exhaust Fumes	3-2
302 TYPES OF VENTILATION SYSTEMS	3-2
1. Dilution Ventilation	3-2
2. Ventilation for Heat Control	3-3
3. Hooded, Gas, Fume and Vapor Handling Systems	3-5
4. Material Handling Systems	3-6
5. Makeup Air Systems	3-7
6. Clean Rooms and Clean Work Areas	3-9
7. Central Systems	3-11
8. Single Systems	3-12





CHAPTER 3: SYSTEMS

301 SYSTEMS APPROACH TO VENTILATION

1. **Consider Building as a Whole.** In the design, alteration or operation of ventilating systems the entire building or facility must be considered as one complex system. This complex system may consist of several subsystems. These subsystems are:

- a. The building or structure forming an envelope around the entire volume or space.
- b. Heating and air-conditioning systems.
- c. Exhaust systems such as for toilet rooms, kitchens, etc.
- d. Laboratory or industrial ventilation systems.
- e. Makeup air systems.

Each subsystem within a building has an effect upon the other subsystems. In order for each of these subsystems to operate effectively and properly they must be considered as working together. All subsystems may not be required to operate at all times. Therefore the effect of one or more air handling systems being shut down for a period of time must be considered.

2. **Makeup and Exhaust Air Balance.** Complete balance between makeup air and exhaust air for the entire building is of utmost importance. Failure to provide this balance is the source of many problems, not only in the laboratory or industrial subsystems, but other subsystems in the building. If insufficient makeup air is supplied, the building will be under a negative pressure compared to the outside atmosphere. Unfiltered and unconditioned air from the outside will leak in through cracks, doors and windows. Doors may be hard to open or may stand partially open depending upon their swing. The effectiveness of heating or cooling systems will be altered by loads imposed by excess outside air being drawn into the building. Undesirable, unplanned air flow patterns will develop within the building. Drafts will

occur and building temperature and humidity conditions cannot be properly maintained. Exhaust systems for hoods will not operate efficiently since additional static pressure is imposed upon the exhaust fans thus reducing their capacity. These conditions may also cause noisy fan operation. There are some cases where it is desirable to maintain a building under a negative pressure. In this instance a balance between supply and exhaust is still necessary but exhaust fans should be selected for the proper capacities at slightly higher static pressures than imposed upon them by the duct system. When it is desirable to maintain the building under a positive pressure the makeup air fan should be selected for the proper capacity at a higher static pressure than imposed by its duct system. Laboratory type buildings are subject to frequent alteration and makeup air must be distributed throughout the building in quantities to balance with exhaust facilities. Alteration of makeup air facilities becomes a major problem. Consideration should be given to initial installation of makeup air equipment with capacities larger than required. This equipment should be fitted with adjustable drives to allow operation at the required capacity. Each case should be given careful study to justify this additional expense. Past experience at a base or facility is the best guide to such justification.

3. **Air Flow Patterns.** Patterns of air flow are set-up within a building as dictated by all the air handling systems in the building. A change or shut down of one system will affect other systems. For this reason laboratory and industrial ventilation systems usually run continuously. The determination to shut down these systems will depend upon the processes being conducted within the building. Design, operation and maintenance must be based upon all systems running continuously unless definite information to the contrary is available. Air flow patterns between rooms can be reasonably predicted. Determination of these patterns is accomplished by construction of a schematic diagram or plan and arithmetic balancing of supply air, recirculated air and exhaust air in each room or space. Air supplied in excess of the amount exhausted will travel to an adjacent area through all available openings. Where exhaust is greater than the amount supplied, air from adjacent

areas will flow toward the exhaust opening. It is recommended that air flow diagrams be developed and maintained for all buildings housing laboratories or industrial type facilities. Every effort should be made to eliminate air flow from one laboratory room to another where there is a possibility of developing a hazardous condition or of causing an unpleasant condition such as spread of odors or change of temperature conditions. Care should be exercised in recirculating from a laboratory or industrial space. "Once-through air" is frequently used in this type of facility. The "once-through air" concept usually requires larger filtering, heating and cooling equipment and therefore usually is more expensive in first cost and operating cost. It does however, provide the safest method of eliminating hazards and discomforts due to mixing and spreading of fumes, vapors, smoke or dust. In cases where spaces are unusually hot or humid due to the process or equipment in the space, the once-through air concept can be less expensive than recirculating the air.

4. Mixing of Exhaust Fumes. The mixture of fumes or gases from different processes or projects can be disastrous. This is particularly true in laboratory-type buildings where different and varying experimentation is being conducted. In this type facility it is often impossible to foresee the mixtures which could be encountered. Such chemical mixtures may be toxic, noxious, explosive or flammable. It cannot be assumed that the personnel working in such facilities will be aware of the various discharge materials from processes other than his own. Therefore, every effort must be made to avoid inadvertent mixing of fumes. Mixing of fumes may come about by air flow patterns within the building, drafts, back drafts, open windows, recirculation of air, or connection of several hoods or exhausts to a common duct or discharge opening. A frequent cause of fume mixing is the alteration of existing facilities. These alterations are frequently of the unauthorized type; such as the addition, deletion or changing of fans, ducts, supply or exhaust openings or dampers, by the using personnel without the knowledge and approval of those responsible for proper operation and maintenance of the facility. Practices of this nature must be discouraged.

302 TYPES OF VENTILATION SYSTEMS

1. Dilution Ventilation.

a. General. The principles of dilution ventilation, methods of calculating air quantities and a considerable amount of pertinent data are presented in the publication "Industrial Ventilation" by the American Conference of Governmental Industrial Hygienists. The information presented here is a condensation of the more pertinent information given in that publication. Dilution ventilation is most often used to control gases or vapors from organic liquids such as some solvents or cleaning fluids. In order to successfully apply the principles of dilution ventilation to a process, factual data must be obtained on the rate of vapor generation or evaporation of the liquid. Dilution ventilation is seldom successfully applied to fumes or dusts because:

(1) They are often more highly toxic and require greater quantities of air for sufficient dilution.

(2) The velocity and rate of generation are usually very high.

(3) Data on the amount of fumes and dust production are very difficult to obtain.

It is important that the difference between fumes and vapors be understood before applying dilution ventilation. Vapor is the gaseous form of a substance which is normally in a solid or liquid state and can be changed to these states either by increasing the pressure or decreasing the temperature. Vapors diffuse. Fumes are small **solid** particles formed by the condensation of vapors of **solid materials**.

b. Limits of Application. The application of dilution ventilation is limited by four factors:

(1) If the quantity of contaminant generated is too great the air volume required for dilution will be impractical.

(2) Workers must be far enough away from the source of contamination, or the generation of contaminant must be in sufficiently low concentrations to prevent worker exposure in excess of the established threshold limit value (TLV).

(3) The toxicity of the contaminant must be low.

(4) The generation of the contaminant must be at a reasonably uniform rate.

c. Principles of Dilution Ventilation. Principles to be applied to successfully utilize dilution ventilation are:

(1) Select from factual data the amount of air required for satisfactory dilution of the contaminant. The publication "Industrial Ventilation" contains tables giving this information for many materials.

(2) Locate the exhaust openings near the sources of contamination, if possible, in order to obtain the benefit of "spot ventilation".

(3) Makeup air must be supplied to replace exhaust air. Makeup air should be heated or cooled as required by conditions to be maintained in the room or space.

(4) Makeup air supply and exhaust air outlets must be located so that all air employed in the ventilation system passes through the zone of contamination.

(5) Air flow patterns within the room or space should keep the source of contamination between the worker and the exhaust opening so all contamination emitted into the space travels toward the exhaust opening.

d. Determination of Air Quantities. A method of calculating air quantities required for dilution ventilation is given in the publication "Industrial Ventilation". Special attention should be given to the selection of proper safety factors ("K" and "C" values).

2. Ventilation for Heat Control.

a. General.

(1) Scope. Ventilation for control of heat may include air-conditioning or cooling. The use, design and maintenance of air-conditioning systems, whether for comfort conditions or for process requirements are out of the scope of this manual. There are situations however, where removal or control of excess quantities of heat to allow human occupation of an area, or to protect a process or installation, is required. It is this application which will be treated herein.

(2) References. The maintenance of comfort conditions by the use of heating, ventilation and air-conditioning is covered by other manuals. In general the applications are covered by the ASHRAE Book. Ventilation for heat control is also covered in the publication "Industrial Ventilation". These references deal with the subject in more depth than presented herein.

(3) Physiological Requirements. The need for ventilation to provide sufficient oxygen for human or animal consumption and to remove carbon-dioxide produced by the body is self-evident. Normally sufficient ventilation for this purpose alone could be obtained by infiltration. There are, however, a number of types of installations where fresh air for these purposes must be supplied. These installations include:

(a) Sealed spaces such as vaults, underground shelters or manholes.

(b) Spaces where oxygen may have been displaced by other products such as carbon dioxide, methane, nitrogen, or hydrogen-sulfide. These include tanks, wells, silos, vats, dry boxes, and tunnels.

(c) Spaces where a special effort has been made to isolate the area from the surrounding environment. Such installations as isolation chambers, clean rooms, etc. are in this category.

The problem of heat balance within the body must be considered. This is a physical problem and not a chemical one. The main part of the human body involved is the skin and not the lungs.

b. Methods.

(1) **General Ventilation.** Exhaust ventilation may be used to remove excess heat and/or humidity if a source of cooler air is available as makeup air. It is desirable to locate exhaust openings as close to the heat source as possible to remove heat as quickly as possible thus reducing the amount of over heating for the entire area. This is not always practical and in some cases general ventilation of the entire volume of the space involved is necessary. In order to arrive at the required volume of air for general ventilation the following information and criteria must be developed.

(a) Determine the maximum allowable temperature and humidity for the space involved. Electrical items of equipment generally should not operate in an environment hotter than 104°F. This temperature is however, too hot for prolonged occupancy by a worker. Effective temperatures for personnel which include allowance for humidity can be obtained from ASHRAE Guide and Data Books or from the publication "Industrial Ventilation".

(b) Determine the maximum temperature of the cooler source of air and its humidity.

(c) Determine the quantity of sensible and latent heat to be released to the space being ventilated.

(2) **Basic Principles.** The following basic principles of ventilation should be observed.

(a) Remove heat as close to the source as possible by locating exhaust openings strategically.

(b) Heat rises. Exhaust outlets for heat should be located above the source and in a manner to eliminate pockets where heat can be trapped.

(c) Locate exhaust openings and makeup air inlets in a manner to take advantage of the flow of cooler air. Cooler air should flow across the occupied zone toward the heat source and then to the exhaust opening.

(d) Even distribution of the cooler air over the entire area is generally desirable. However, there are instances where cooler air supply may be directed to a spot or local area to take maximum advantage of its cooling effect.

(e) The cooler air supply should be introduced low enough to be effective in the occupied zone.

(3) **Hoods and Enclosures.** If the heat source can be hooded or placed in a separate enclosure the removal of heat is simplified. Maximum use of baffles and hoods is advantageous. Hood face velocities should be sufficient to capture the hot rising air. Usually a velocity of 100 f.p.m. is sufficient.

(4) **Spot Cooling.** Certain applications require relief from heat in a small area or spot within a larger area. Applications of this nature are referred to as "spot cooling". Spot cooling is accomplished by directing a cooler air supply to the immediate area needing the maximum cooling effect. Air blown from a small opening retains its directional effect for a considerable distance beyond the plane of the opening. Therefore spot cooling should be accomplished by directing a stream of makeup air from a supply system utilizing a blower. The velocity as well as the temperature and humidity of the supply air is important. If the air dry-bulb or wet-bulb temperature is lower than 95 – 100 °F, the worker may be cooled by convection or evaporation. When the dry-bulb temperature is higher than 95 – 100°F, increased air velocity may add heat to the worker by convection. If the wet-bulb temperature is high also, evaporative heat loss may not increase proportionately and the net result will be an **increase** in the worker's heat burden. Supply air temperature should not exceed 80°F for most effective ventilation. Directional control of the outlets should be provided.

(5) Radiation. Since radiation is a process of heat transfer which requires no medium for this transfer, radiation cannot be controlled by any of the above methods. Painting or coating of the surface of hot bodies with materials having low radiation emission characteristics is one method of reducing radiation. In some instances radiation shields are effective. This subject is covered in detail in the publication "Industrial Ventilation" and in the ASHRAE Guide and Data Books.

3. Hooded, Gas, Fume and Vapor Handling Systems.

a. General. The following principles refer to systems utilizing hoods or enclosures as an integral part of the system, as opposed to dilution ventilation systems. These systems are also intended for removal of gases, fumes and vapors as opposed to those used for dusts or material handling. In the majority of gas, fume and vapor handling systems no separators or collectors are required and the gases, fumes and vapors are discharged to atmosphere. This is not always the case however, as in the case of a paint spray booth which normally utilizes either filters or a water spray separator; or in the case of a kitchen range hood with grease filters. Capture velocities at the hood openings and duct velocities are generally lower in gas, fume and vapor systems than in material handling systems. Hood openings in gas, fume and vapor systems are usually much larger than those in material handling systems, and therefore require more exhaust air even though the velocity is lower. Hooded systems are generally preferred to dilution systems if they can be used. Exhaust air quantities are less than for dilution ventilation, consequently makeup air is less. Hooded systems remove the contaminant at its source, are more efficient, and provide a greater degree of protection for the worker. However, the hood location and design should be such that the contaminated air is not drawn past the operator.

b. Common Uses. Hooded gas, fume and vapor handling systems are usually used for laboratory type buildings; for ventilation of vats or open tanks in industrial processes; for kitchen range and dishwasher systems; in automotive maintenance garages for engine exhaust systems; for paint spray

booths; for welding area ventilation; and a variety of other uses.

c. Precautions. Vapors are gaseous and tend to diffuse. Fumes are extremely light airborne particles and will spread or be carried away by drafts and air currents. It is therefore essential that undesirable drafts or air patterns be kept to a minimum in the vicinity of a hood opening. Capture velocities at the hood must be sufficient over the **entire** face of the hood. In many type installations, particularly in laboratory type buildings where it is impossible to predict the nature of all future operations, every effort must be made to prevent inadvertent mixing of fumes and vapors between hoods or within exhaust ductwork. Condensation within discharge ducts is common. Provisions must be made for draining and this can be done by sloping the duct and providing a drain at the low point in the duct. It is usually a good practice to provide a trap in these drains to prevent passage of air through the drain piping. In some cases the duct may be sloped to drain back to the hood. Before this is done the application should be thoroughly studied to determine if such a drip or drain will cause a hazard or interfere with the process. Corrosion within the hood, ductwork and exhaust fan is a common problem. The selection of materials and equipment should be based upon the process, application and desired life of the system. Fumes, gases and vapors often produce odors and may be toxic, noxious, flammable, explosive or corrosive. The location of the discharge from these ventilation systems should be carefully studied. Prevailing winds, the proximity of other buildings, air currents or winds set up by adjacent buildings, the location of outside air intakes in the same or adjacent buildings, and the materials of any nearby surface the discharge may impinge upon should all be taken into consideration when locating the discharge openings. Upon completion of a new system or alteration of an existing system, the entire system should be tested to insure the system is operating as intended. The extent of these tests depends upon the processes being conducted in the hoods. Where radioactive or toxic materials are involved, face velocities, air flow patterns, air volumes and drafts should be thoroughly tested and air sample testing is recommended.

4. Material Handling Systems.

a. General. The systems referred to in this paragraph are those intended to handle solid materials such as dusts, abrasive materials, chips, and fibers. These systems are generally found in industrial type buildings however certain laboratory type operations involve ventilation for dust removal as well as a limited amount of other material removal and collection. These systems are generally composed of a number of local hoods connected by ductwork to a material separator-collector, and includes an air moving device, usually a fan.

b. Hoods. The materials normally handled by this type of system are rather heavy (100 or more grains per cubic foot) and are expelled from a machine or process at a rather high velocity and in a given direction. Most of these materials, if not captured by such a system, will settle out of the surrounding atmosphere in a relatively short period of time. Finer dusts will however, remain airborne for longer periods and will be carried by normal air currents and drafts to the surrounding areas where they settle out when air current velocities are sufficiently low. Hoods for material handling systems must therefore be designed for the particular process, machine and material involved. Due to the mass of the material to be captured and its velocity upon leaving the machine or process, it is not practical to attempt to capture these particles by air velocity alone. The location and design of the hood becomes of utmost importance. The more completely a hood encloses a process the more efficient it will be in capturing the material ejected. The opening in the hood or enclosure must of course be located and sized so as to present no obstruction to the process or worker. Air flow through this opening or hood face should travel in the same general direction as the material ejected from the machine or process. In this way the air currents will not have to overcome the momentum of the particles of material but will instead take advantage of this momentum to assist in carrying the material into the ductwork. Air velocity in all portions of the hood must be sufficient to carry the material and not allow it to settle and accumulate. There are some processes or machines that cannot be enclosed. In these cases the

hood should be located to take advantage of the motion or travel of the material being ejected. The face velocity must then be sufficient to capture the material at its point of origin. There are as many types and designs of hoods as there are machines or processes. Data for design of many hoods is given in Chapter 4 and in the ASHRAE Guide and Data Books, and in the publication "Industrial Ventilation". The latter reference illustrates the recommended locations and configurations of many hoods as well as giving design data.

c. Ducts. Ducts used in material handling systems should be constructed of a heavy gage metal, terra-cotta pipe or other suitable material. Ducts should be round in cross-section with interior joints smooth. Branches should enter the main duct at a 45° angle or less. Elbows should have a long radius. Transitions in duct size should be smooth and gradual. Sizing of ducts must be such that velocities will not drop below those recommended for the material being handled. Clean-out plates or access should be provided at frequent intervals on straight runs and at each major change in direction except that it is not necessary where the flow is from horizontal to vertical down flow. Blast gates or valves should be provided close to connections to each machine to allow shutting off of an individual hood when not in use, unless the system is designed to operate without blast gates. Material conveying velocities for many materials and processes are shown in the ASHRAE Guide and Data Books. Sizing of ductwork for material handling requires special attention. Air quantities cannot be determined until all hood configurations are firmly set. A judgement must then be made as to which hoods will be in use simultaneously. The sizing of a branch duct to a single hood presents no problem. Ducts handling multiple hoods or branches must be carefully analyzed. Velocities must not be allowed to drop below the minimum recommended for the material being handled on one hand, and velocities must not be increased above reasonable limits due to noise, pressure drop and increased abrasive action on the other hand. Where provisions are required for future alterations or additions open end stub branches with blast gates or orifices may be used to aid in balancing air quantities. Where more than one type

material is being handled by a single duct the velocity must not drop below the highest velocity recommended for the materials being handled. The calculation of pressure loss within the duct system must include the entrance loss for the hood, resistance losses of the ducts, elbow, junctions and fittings, and acceleration or deceleration losses from velocity changes in the system.

d. Air Moving Device. The principle types of air moving equipment are as follows:

(1) Centrifugal fans are most frequently used due to system pressures involved. Where separators or collectors are involved it is usually advantageous to locate the fan on the clean air side of the separator. The paddle wheel or modified paddle wheel fan designs are heavily constructed and have few blades to make them more suitable if wear, corrosion, or accumulations are a factor. The higher efficiency backward curved blade designs are suitable where relatively clean, noncorrosive air is handled. Forward-curved blade designs have limited application due to the number, shape, and metal thickness of the short curved blades.

(2) Axial flow fans may be used for systems having low-pressure losses. Propeller or disc designs develop pressures under one inch water gage. The vane-axial designs develop higher pressures but are not recommended where pressures exceed 3 inches.

(3) The venturi-ejector is an inefficient method of air movement, but has the advantage of causing air flow without having the exhaust air pass through the air flow producing equipment. It minimizes the explosion or corrosion potentialities in certain types of systems.

e. Capacities. Fan capacities cannot be selected, nor can ducts be sized until the hoods contained in the system are designed. When hood configurations are firm, air velocities and quantities can be established for each hood or branch duct. In many material handling systems, such as in wood working or metal working shops, all hoods are not required to be in operation simultaneously. This is

the prime reason for installation of blast gates or valves in the ductwork as mentioned hereinbefore. A judgement must be made as to the percent of use of the various machines. The system must be analyzed carefully before determining the capacity of the air moving device. This determination will also determine the size of the air cleaning equipment to be selected. Belt driven fans most often are selected since they present means of adjusting air volume and pressure. Fans should be rated by the Air Moving and Conditioning Association (AMCA), and should be of the proper class for the operating conditions encountered.

f. Air Cleaning Equipment. Air cleaning equipment is available in a wide range of designs to meet the various requirements. This equipment can be divided into two general categories, air filters and dust collectors. Air filters are designed for removal of dusts and air contaminants which are very small in particle size and low in concentration and are not generally found in material handling systems of the order covered here. Sophisticated systems handling highly toxic or radioactive materials in fine particles may use filters. Dust collectors are usually designed for much heavier loads. Dust collection equipment is available in a wide variety of designs and principles and vary widely in first cost, operating cost, space requirements, arrangement and materials of construction. These types are described elsewhere in this manual.

5. Makeup Air Systems.

a. General. Makeup air is a term used to indicate the supply of outside air introduced into a building to replace air removed by exhaust ventilation and combustion processes. In some buildings where the quantity of exhaust air is small compared to the building volume the exhaust system will induce sufficient air flow into the building to replace that being exhausted and at the same time not produce adverse effects. These cases are rare particularly in modern buildings where construction is tight. Makeup air not only replaces the volume of air exhausted but can also be used to serve as supplemental, general ventilation for comfort. The volume of makeup air should equal

the volume of exhaust air in all parts of the building unless it is desirable to establish air flow patterns from one area of a building to another. The need for makeup air should not be based upon "air changes" figures since there is a great variation between new and old buildings, as well as difference in basic building types. A relatively old building with large window areas is "open" and air leakage is pronounced. Modern masonry buildings with little or no window areas are practically air tight and such a building would starve for air if natural infiltration were depended upon for makeup air. Makeup air is important for the following reasons:

(1) To insure that exhaust hoods operate properly. A lack of makeup air creates a negative pressure condition which increases the static pressure which the exhaust fans must overcome. This causes a reduction in exhaust volume and it is particularly serious with low pressure fans such as wall fans and roof exhauster. Decreased exhaust fan capacity in turn reduces hood face velocities. In cases where several exhaust fans are operating the "stronger" fan may actually cause reverse air flow through the "weaker" fan outlet.

(2) To insure the proper operation of natural draft stacks such as combustion flues and vents. It is not uncommon to find reverse air flows through combustion vents of small boilers, heaters and water heaters. This reverse flow carries products of combustion into the building and causes pilot lights to be blown out. Such a condition could be deadly since carbon monoxide could be carried into the building.

(3) To eliminate high-velocity cross drafts through windows and doors as well as from one room or area to another. These drafts not only interfere with the proper operation of the exhaust systems and hoods but also disperse contaminated air from one section of the building to another — a dangerous condition in many laboratory type buildings.

(4) To eliminate cold or hot drafts on the workers.

(5) To eliminate differential pressure on doors.

b. Application. One of the primary considerations in the design of makeup air systems is the location of the outside air intake. This intake should be located so that air, fumes, smokes, and other contaminated exhausts from the building, or from adjacent buildings, will not "short cycle" or enter the makeup air inlet. Prevailing winds should be noted. Intakes should be high enough to prevent the taking in of dust or dirt from the surrounding areas. Engine exhausts should not be located so the fumes can enter the intake. All outside air should be filtered before introducing it into the building. This eliminates unnecessary entry of dirt and insects, and protects surfaces of heat exchange equipment in the makeup air system. The makeup air system must be provided with a fan. Otherwise the building will be under a negative pressure since exhaust fans must pull the air through the resistance of filters, coils, and ductwork. Makeup air outlets should be located to distribute the air to all parts of the building as required to balance exhausts or establish air flow patterns as desired. In some cases these outlets may be located to provide cross ventilation or may be directed at a single location providing "spot cooling". In this way the makeup air is utilized in two ways. There are also cases where it is desirable to locate makeup air outlets near inlets to hoods of the exhaust system to prevent the exhaust system from pulling excessive "room air" out. This is sometimes done in air conditioned areas. If the makeup air is not conditioned it creates a small area in the immediate vicinity of the exhaust hood which is not as comfortable as the rest of the area. Where use of makeup air for general ventilation is desired the outlets should be located in the occupied or "living zone" of the building. That is the outlets should be below the 8 to 10 foot level. When makeup air is introduced into the occupied zone of the building it is usually heated or cooled to the temperature being maintained in the building and is not relied upon for heating or cooling the building.

c. Equipment. Types of makeup air equipment vary widely from special makeup air

units to conventional air handling equipment. In any case the equipment should include a fan and filters. Heating may be by steam or hot water coils, direct-fired heat exchangers using gas or oil and by open flame heaters. Care must be exercised in using hot water coils to prevent freezing of the water in cold weather when the system is down. Open flame heaters present problems with the products of combustion since the flame is in the makeup air stream. This type system is the least desirable and should be used only after careful consideration of the health and safety factors involved. Cooling of makeup air may be accomplished by using chilled water coils, direct expansion refrigeration coils, or in some localities evaporative cooling.

d. Cost of Conditioning Makeup Air. The term "conditioning" refers to heating or cooling of the air or both heating and cooling as required. It must be emphasized that makeup air will always enter the building by some means; otherwise the exhaust fans cannot function. Further, this air will be heated or cooled eventually by inefficient mixing, while still producing all the disadvantages in air leakage and inefficient exhaust ventilation. It is more economical to introduce the air through makeup air equipment whereby its temperature and distribution can be controlled. The publication "Industrial Ventilation" gives a method of calculating cost of heating makeup air.

6. Clean Rooms and Clean Work Areas.

a. General. The air about us contains large amounts of contaminants, both gaseous and particulate. Clean rooms and clean work areas as covered herein are concerned with the problem of particulate contamination. Increased contamination poses problems in the more sophisticated manufacturing, and assembly facilities, in laboratories and in other critical operations requiring extreme cleanliness. Operations of this nature are conducted where: (1) airborne particles are limited, (2) air flow patterns are selected, (3) temperature and humidity are controlled, (4) air pressure is regulated, (5) special materials and construction are employed, and (6) operating procedures are regulated. These spaces may be of a variety of configurations, types and classes. The

design, operation and maintenance of such facilities involves far more than ventilation alone, is quite involved and is therefore out of the scope of this manual. In addition to ventilation other specialties involved are air-conditioning, lighting, structural, painting or finishing, electrical, electronic specialties and others. This manual will only present familiarization to help those who are unfamiliar with such facilities, to better understand their use and complexity.

b. Need and Performance. The need for a clean room or clean work area and criteria for its performance is dependent upon the process or activity to take place within that space. It should be remembered that a clean room or clean work area will not clean an item placed in that space nor will it prevent contamination of the item by direct transfer from the workers hands or tools used to handle the part.

c. Air Flow Patterns. Clean spaces, particularly rooms, may have conventional air flow or laminar air flow. The term "conventional air flow" pertains to a system where supply air enters through grilles, registers or diffusers in the walls or ceiling and leaves the space via grilles or openings in the floor or walls of the space. Conventional air flow patterns are not linear, parallel or uniform in velocity therefore eddy currents are usually present. In laminar air flow patterns the air enters the space uniformly over one entire surface of the enclosed space such as a wall or the ceiling. The air then travels in parallel lines of flow and at a uniform velocity to the opposite surface of the space, where it leaves the space through a grilled surface or opening over the entire surface. The velocity of the air in laminar flow spaces is usually about 90 feet per minute. Variations of the laminar flow concept are often used. Probably the most frequent variation encountered is in the arrangement for air to leave a laminar flow space. In many rooms multiple grilles evenly spotted over a surface will be used for air to leave the room. In portable type clean spaces where plastic curtains are used as walls the air leaves the space by passing between the lower edge of the plastic curtain and the floor. In both of these arrangements flow is not truly laminar since air must change its direction upon striking the wall or

floor. However, the eddies caused by this change in direction and subsequent change in velocity are out of the general work area and are acceptable for many processes. Laminar flow may be vertical, entering at the top of the space and leaving at the bottom; or it may be horizontal. In horizontal laminar flow the flow must be across the work surface toward the worker. In an empty clean facility one arrangement is as good as the other. However when a facility is in use, occupied by the worker and/or his equipment, contamination is introduced internally and may be carried by the air flow patterns to various locations and items in the space.

d. Classes. As a means of classifying the performance of a clean room or clean work area three classes have been established. Federal Standard No. 209 defines these classes as follows:

- Class 100,000 — Particle count not to exceed 100,000 particles per cubic foot of a size 0.5 microns and larger, or 700 particles per cubic foot of a size 5.0 microns and larger.
- Class 10,000 — Particle count not to exceed 10,000 particles per cubic foot of a size 0.5 microns and larger, or 65 particles per cubic foot of a size 5.0 microns or larger.
- Class 100 — Particle count not to exceed 100 particles per cubic foot of a size 0.5 microns and larger.

e. Types of Spaces.

(1) Clean Rooms. Clean rooms are specially constructed permanent rooms and may have conventional or laminar air flow. Usually facilities of this type utilize laminar flow or a modified laminar flow air pattern. Many rooms are provided with air locks or for personnel or material entrance. These air locks or anterooms are clean spaces within themselves and are purged of contaminated air before being opened to allow passage into the clean room. Shoe cleaners and special clothing are often employed. Such rooms have closely controlled temperature and humidity.

In some facilities of this nature operations such as solvent cleaning are conducted. When vapors or fumes of this nature are generated within the room they must be removed and not recirculated. Hoods are provided at the location of the process to capture the vapors or fumes. It is important to exhaust as small amount of the room air as possible and still remove the vapors or fumes effectively. The more room air exhausted the more makeup air is required. Excess makeup air imposes unnecessary loads on the filters and air conditioning system. Clean rooms are always operated under a positive pressure to eliminate infiltration. Where laminar flow is employed one wall or the ceiling of the clean room is usually composed of approved fire resistant High Efficiency Particulate Air (HEPA) filters through which the air enters the room.

(2) Portable Clean Room. Portable type clean rooms are much less sophisticated than those described above. The term "portable" is somewhat misleading. There are a number of designs which fall into this category. One type could better be described as "Prefabricated". It is composed of insulated panels forming the exterior walls, floor and top. Equipment is selected and arranged for ease of installation. This type room may be disassembled and moved to various indoor locations. These rooms are not usually true laminar flow. Air is usually supplied through an approved fire resistive HEPA filter bank either in the ceiling or wall but not covering the entire surface. Air leaves the space through grilles located in the floor or walls. Another "portable" type clean room or clean work area is constructed with an approved fire resistive HEPA filter bank forming the ceiling and a plenum above the filters. (See Figure 3.1). The supply fan draws air through prefilters from the space surrounding the clean room or clean work area and discharges into the plenum. The HEPA filters, plenum, fan and prefilters are supported by tubular legs with casters on the foot of each leg. The walls of the room or space are composed of clear plastic curtains attached to the HEPA filter frame and extending down to within a few inches of the floor. These plastic curtains are fastened to one another on the vertical joints by zippers or other such means. These zippers also are used as a means of access into the space. The filtered air

travels from the HEPA filter ceiling down to the floor; thence across the floor and out from under the plastic side curtains into the space surrounding the portable clean room or clean work area. This type unit is used within an air-conditioned room and utilizes the cool air of that room. Units such as these are in wide use where extreme cleanliness is not required. This clean room or clean work area ceases to be such a room when the fan is off. Cleanliness is dependent upon the space enclosed by the curtains and filters to be under a positive pressure so all air flow is clean air which flows "out" of the space. When the fan is off contaminated air will infiltrate into the room.

(3) Clean Benches. Clean benches or work areas may be employed either within a clean room or in a contaminated space. It provides a limited work station while it is in operation. Clean benches consist of a hooded or partially enclosed bench with a HEPA filter bank forming the rear wall or the ceiling of the inclosure. (See Figure 3.2). A plenum encloses the intake side of the filters. A small fan and prefilters are provided. Air flow is through the HEPA filters, across the work surface toward the worker. The use of clean benches in lieu of clean rooms is recommended where the size of the work and degree of cleanliness permits.

f. Filters.

(1) HEPA Filters. High Efficiency Particulate Air Filters have an efficiency of, or in excess of 99.97 percent for 0.3 micron particles. This efficiency is determined by Dioctyl Phthalate (DOP) Test according to Military Standard MIL-STD-282. There must be no leakage around these filters. Care must be taken and tests run to determine if there is leakage between the filter rack and the filter frame, or between the filter media and the filter frame. Filters of this type are expensive and therefore should be protected by relatively inexpensive prefilters in order to extend their life.

(2) Prefilters. Prefilters may be of a number of types. Usually they consist of throw-away type filters or of disposable roll-up type filter media. The purpose of the prefilter is to

catch the relatively large particles of material in the air flow before they reach the HEPA filters thus prolonging the life of the HEPA filters.

g. Maintenance. Maintenance of the fans and prefilters of a clean space is no different than that of other fans and filters with one exception. Special care must be taken in removing and replacing prefilters to prevent dirt or contaminant particles being knocked off the prefilter and collecting on the down stream side of the prefilters, thus unnecessarily loading the HEPA filters. HEPA filters have a long life if properly protected. Replacement of HEPA filters is a task which must be done with extreme care. As mentioned before, tests must be run to detect leaks and care must be exercised to prevent damage to the HEPA filter media.

h. Operating Procedures. Operating procedures for clean spaces are usually worked out by those responsible for the process taking place. Clean space procedure is usually exacting and covers use of proper clothing, gloves, shoes, entry of personnel and materials and clean-up.

7. Central Systems.

a. General. The term "Central System" refers to a ventilation system which employs a single air moving device with ductwork and serves several areas or hoods within a building. More than one central system may be in a single building. A central system may be for exhaust, supply or makeup air. Ductwork is usually extensive and consists of a main duct and branch ducts serving the several areas or hoods.

b. Application. Central systems are commonly used for a variety of facilities. Most air conditioning and warm air heating systems are of the central type. Makeup air systems as generally envisioned herein are of the central system types. Central exhaust ventilation systems are frequently used for:

- (1) Material handling.
- (2) Heat removal.

- (3) General ventilation.
- (4) Toilet room exhausts.
- (5) Automotive garage engine exhaust.
- (6) Dilution ventilation.
- (7) Exhaust from several hoods of a single type process or from compatible processes.

c. Advantages. Central systems are generally lower in first cost than are local systems. A single large fan with its motor and drive and ductwork is less expensive than multiple fans and motors of a smaller size. Electrical service is usually less expensive since it is centralized. Usually less space is required for the larger fan and drive, although this is not always true.

d. Disadvantages. Central exhaust systems for laboratory and industrial type ventilation have several serious draw backs. Central exhaust systems are difficult to balance and to coordinate with the makeup air system since any change to one intake will effect all other intakes, thus creating cross air currents or air flow patterns which are not desirable. When multiple hoods are connected to a single duct mixing of the various vapors and fumes are likely to become a problem. This mixture may easily become corrosive, flammable, explosive or toxic creating a health hazard as well as decreasing equipment life. Laboratory and industrial facilities require frequent alteration. Alterations to a central system requires careful study and extensive engineering and testing. The capacity of the fan may be altered by changing the fan speed or the static pressure the fan must operate against. Addition or deletion of ductwork will require changes in capacity and may change the static pressure. Such changes may require a change in the motor horsepower. The entire system must be rebalanced whenever any portion of it is revised. These alteration problems apply to makeup air and exhaust systems alike. Balancing of supply air systems may be made easier by the use of constant volume dampers.

8. Single Systems.

a. General. The term "single system" as used herein refers to a ventilating system utilizing a single air moving device and serving a single area or hood. Such a system may be an exhaust, supply or makeup air system. Systems of this type do not require balancing within themselves although they must be of capacities to balance with other systems. Such systems usually have a limited amount of ductwork.

b. Application. Systems of this type may be used for air conditioning and warm air heating of small isolated areas, makeup air systems for a single room laboratory or shop of small size and for various types of exhaust systems. Single systems lend themselves to exhaust type systems and are used for:

- (1) Laboratory hoods.
- (2) Heat removal.
- (3) Dilution ventilation.
- (4) Toilet ventilation.
- (5) Intermittent operating systems.

c. Advantages. This type system employs small fans, motors and ductwork and can be fitted into buildings readily. Fans are frequently roof mounted. There is no mixing of fumes or vapors to cause hazards. Fans and ducts may be constructed of materials to suit the application and not the most hazardous condition as in central system. Ductwork can, in many instances, be run straight up through the roof and are short thereby reducing problems of condensation. When a system must be altered the smaller equipment is less expensive to replace. Multiple fans allow more flexibility of operation and maintenance procedures and require much less engineering effort for alterations.

d. Disadvantages. Roof mounted fans in large numbers can detract from a building's

appearance, and may also cause increased maintenance on the roof itself due to traffic walking on the roofing. Care should be exercised to insure that ductwork handling any toxic, noxious, flammable or explosive fumes or vapors be installed on the intake side of the fan to prevent spreading of the fumes or vapors through leaks in ductwork.

e. **Recommendations.** It is recommended that single type exhaust systems be

employed for laboratory type hoods. Industrial type facilities having processes which are not compatible should use single type exhaust systems. Single exhaust systems should be used to handle any toxic, noxious, flammable or explosive fumes or vapors. Fans should be located at the terminal end of the exhaust ducts whenever possible so ductwork will be maintained under a negative pressure.



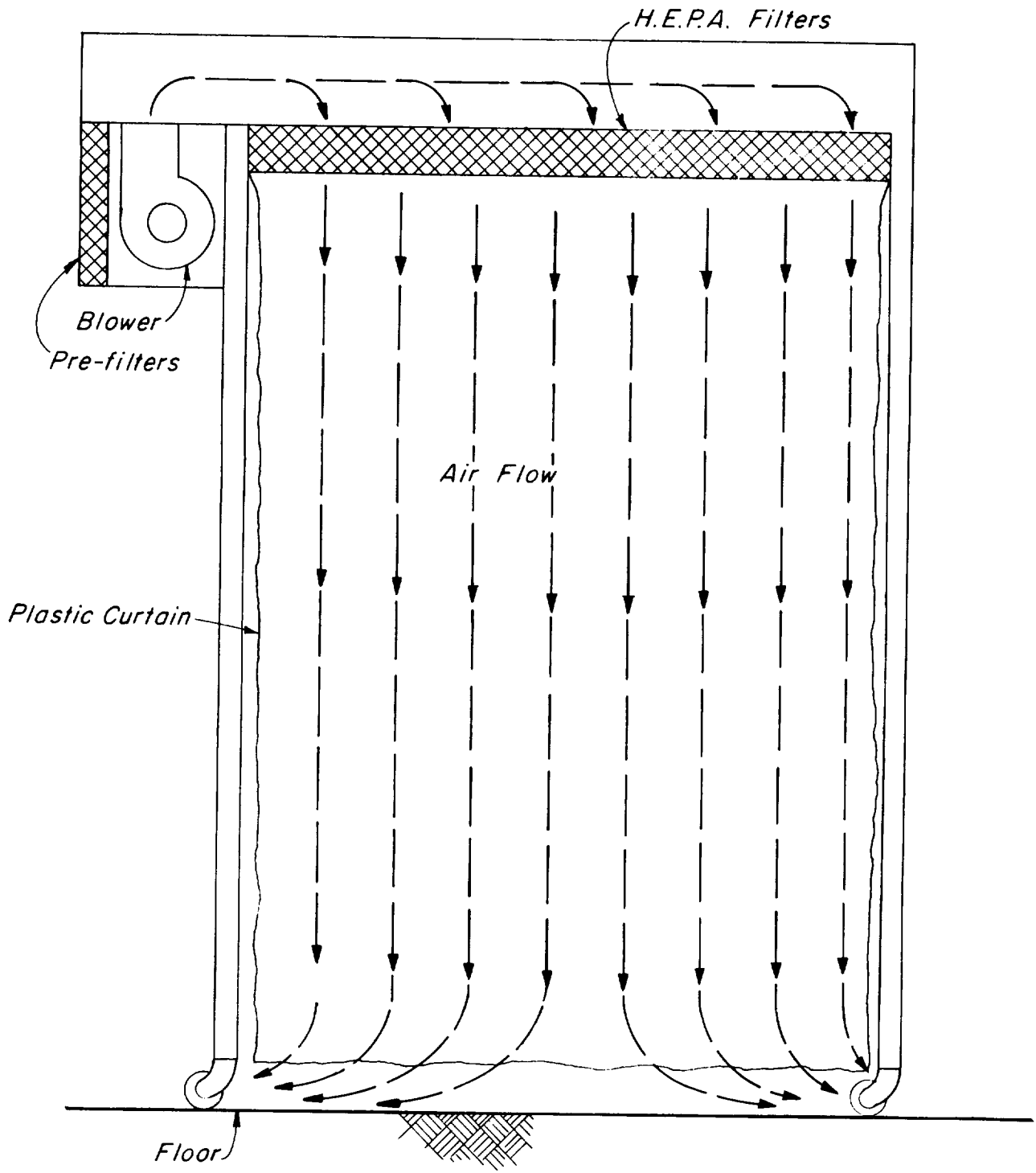

CURTAINED "LAMINAR" FLOW UNIT

Figure 3.1

Figure 3.2

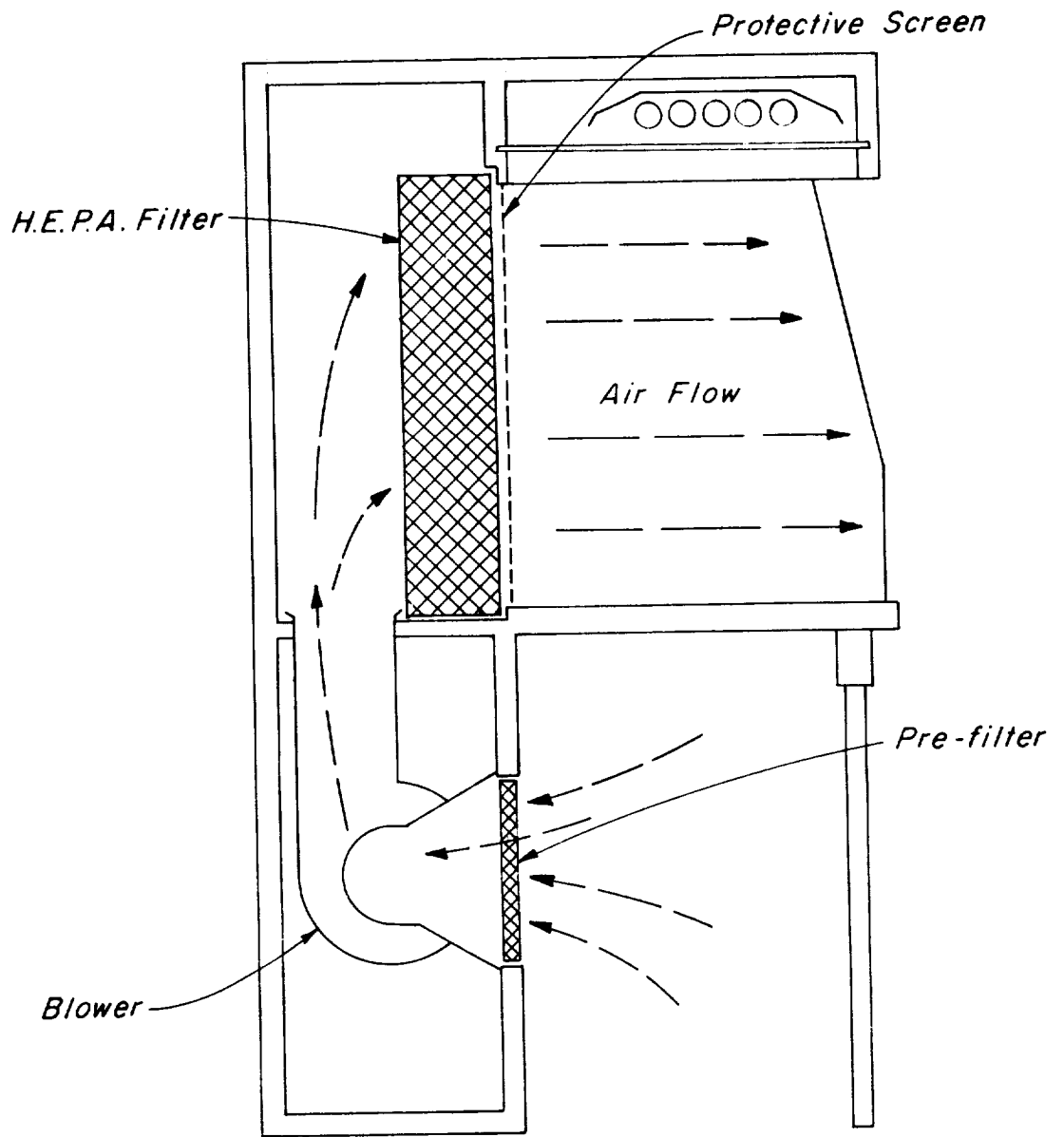

"LAMINAR" FLOW CLEAN BENCH
Figure 3.2

CHAPTER 4: HOODS AND EQUIPMENT

TABLE OF CONTENTS

Paragraph		Page
401	HOODS	4-1
1.	General	4-1
2.	Principles	4-1
3.	Canopy Hoods	4-1
4.	Laboratory Fume Hoods	4-2
5.	Open Surface Tank Hoods	4-6
6.	Flexible Branch Hoods	4-6
402	EQUIPMENT	4-7
1.	Air Moving Devices	4-7
2.	Motors and Drives	4-9
3.	Air Cleaning Equipment	4-9



CHAPTER 4: HOODS AND EQUIPMENT

401 HOODS

1. General. Proper design of exhaust hoods is essential if the ventilation system is to effectively control air contamination at its source with a minimum of air flow and power consumption. Complete technical data for design of exhaust hoods of the many types are out of the scope of this manual. Technical data to guide the hood designer can be found in the publication "Industrial Ventilation" and in the ASHRAE Guide and Data Books. General principles and considerations in determining the proper types of hoods are discussed herein.

2. Principles. Dust particles of the small micron size, even when propelled at very high velocities, travel a very short distance in air. Fine dust particles of the type that generally constitute a health hazard are referred to as "airborne." Vapors and gases, on the other hand, mix readily with air and follow air currents. Larger dust particles when released at high velocities do travel a considerable distance due to their mass and momentum. The theory of capture velocity depends upon the creation of an air flow at the source of the contaminant of sufficient velocity to capture the contaminant and carry it into the hood. Capture velocity is the velocity at any point in front of the hood or at the hood opening which is necessary to overcome opposing air currents and capture the contaminated air at that point by causing it to flow into the hood. Large dust particles released from a process at very high velocities cannot be captured unless they are directed into the hood when they are released. Hood design requires a basic knowledge of the process, the equipment and the contaminant. Cross currents of air flow must be reduced to a minimum. By the use of baffles or flanges the ill effects of drafts and cross flow of air currents can be reduced. These baffles or flanges can also reduce the scattering of larger dust particles as well as reduce the quantity of air to be exhausted. The more complete the enclosure, the more efficient the hood will operate. Openings should be as small as possible and located away from the path of the particles released. The exhaust duct connection should be located as close as practical to being in

the path of the released particles thus taking advantage of their mass and velocity. Where hoods are large and shallow the air flow tends to be concentrated in the vicinity of the exhaust duct connection. In such cases it is advisable to use multiple duct connections. It is only after the hood has been designed that air quantities can be determined. Recommended hood types and ventilation rates for some materials are given in the ASHRAE Guide and Data Books and in the publication "Industrial Ventilation."

3. Canopy Hoods. Canopy hoods are effective for control of hot processes and where sudden surges of hot gases and vapors are released. Canopy hoods should not be used where workers must work directly over the process such as with some tanks and vats. Such an installation would draw the contaminant across the worker rather than away from the worker. Canopy hoods also present problems where cranes or mechanical hoists must be used. Due to the nature of canopy hoods they require large volumes of air to be exhausted thus requiring large makeup air loads. By locating canopy hoods on a wall or by using baffles or sides to enclose the process to the maximum extent practical the hood can be made more efficient and large quantities of air saved instead of exhausted. Velocities decrease rapidly as the distance from the hood opening increases. Therefore canopy hoods should be located as low as possible over the process without obstructing head room. The hood should be designed to overlap the perimeter of the source of contaminant. It should be pointed out however, that exceptionally large volume hoods require less air volume than would be indicated by the capture velocity values recommended for small hoods. This is true for the following reasons.

- a. The presence of a large mass of air moving into the hood.
- b. The fact that the contaminant is under the influence of the hood for a much longer period of time than is the case with small hoods.
- c. The large volume of air creates dilution ventilation effects.

Canopy type hoods are frequently used as kitchen range hoods and for some types of furnaces. Lighting is frequently installed inside of hoods. Fixtures should be vapor proof and in some instances explosion proof if the process warrants it. Fire protection systems are installed in many kitchen range hoods. The fire protection system most frequently used is a steam smothering system. Valves and controls should be remotely located to be accessible in case of fire.

4. Laboratory Fume Hoods. Fume hoods are used to confine and remove odoriferous, toxic or corrosive fumes generated in the laboratory. Properly designed, installed and operated, fume hoods can accomplish this at relatively low face velocities. Proper installation must include proper design and installation of other systems such as building heating and air-conditioning systems, and makeup air systems. Unnecessary drafts and air flow patterns must be kept to a minimum. Cross drafts, in some cases as small as those caused by personnel walking past an open fume hood, can cause fumes to escape into the room. There are many types of laboratory fume hoods. For purposes of this manual laboratory fume hoods have been classified by the following air flow types: conventional air flow type; bypass air flow type; auxiliary supply air type; glove or dry box type. Most laboratory hoods will fall into one of these categories. The selection of the proper fume hood for a given laboratory is important. Hoods of this type are manufactured by a number of companies which specialize in this equipment. Not only is the type of air flow pattern important but materials of construction, lights, utility outlets, cleaning apparatus, drains, etc. must be considered.

a. Conventional Air Flow Type. The conventional air flow type hood consists of an enclosure with three fixed sides, a bottom and top. The front consists of a sash which is raised vertically or is split into two sections which slides horizontally. The hood is connected to the exhaust ductwork, the connection being on the top in most cases. With the sash tightly closed no air flows through the hood and the fan is starved for air. When the sash is opened slightly air is drawn in at a high face velocity causing eddies and drafts within

the hood. As the sash is opened further, the face velocity drops. This type of hood can only be used for certain types of laboratory work. The air exhausted is 100% room air. Makeup air must be supplied into the room in a quantity equal to exhaust air when the sash is open and is therefore excessive when the sash is closed. This type of installation is usually unsatisfactory and should be avoided. Figure 4.1 shows a conventional laboratory hood. Where hoods of this type are installed consideration should be given to the installation of automatic, weighted dampers in the exhaust duct to allow balancing of exhaust and makeup air.

b. Bypass Air Flow Type. The bypass air flow laboratory hood is an improvement to the conventional type. A plenum is added to the upper front of the hood and the sash rises into this plenum as it is opened. A grille for air intake is normally located on the front or top of this plenum. The plenum is arranged to cause air flow from the room into the face of the hood when the sash is open (similar to conventional type). When the sash is closed, air flow is from the room into the plenum and then into the upper front of the hood. A further improvement is the addition of a slot under the sash opening through which air can flow at all times. This air flow will sweep the bottom of the hood. A baffle is normally installed on the back of the hood to cause the air flow to be partially picked up from the bottom of the hood. Figure 4.2 illustrates this type of hood. The addition of this plenum allows 100% room air to flow through the hood at all times. The fan is no longer starved for air. Makeup air must still be introduced into the room. However, the quantity of exhaust air is constant, therefore makeup and exhaust air can be balanced at all times. An additional improvement found in this type hood is the "stream-lined" or "air-flow" design on the front which eliminates abrupt offsets and therefore reduces eddies. The face velocity for this type hood does vary with the sash position but to a much lesser degree than in the conventional hood. This type of hood is in wide use.

c. Auxiliary Supply Air Type. The auxiliary supply air type laboratory hood is still a further improvement in hood design. The plenum as

installed on the bypass air flow type has been enlarged and equipped with a supply air duct connection. The grille on the front of the plenum is arranged to discharge air downward in front of the hood face. The sash controls the air flow of the supply air introduced into the plenum by the duct. When the sash is closed, air from the supply duct flows through the plenum into the upper front of the hood. When the sash is opened the air from the supply duct flows through the plenum and is discharged downward through the grille and in front of the open hood face where it is drawn into the hood. Some room air is also drawn into the hood at all times. Figure 4.3 illustrates this type hood. With this type of hood 30 to 50 percent room air is exhausted and the balance is auxiliary supply air. This type hood has the advantage of a more constant face velocity. The air flow patterns in front of the hood are more easily controlled when the sash is open. Since most of the exhaust air is auxiliary supply or makeup air supplied direct to the hood it is often not necessary to heat or cool this air although its temperature should not be allowed to vary too far from room conditions. The amount of makeup air which must be introduced directly into the room is reduced. However, total makeup air quantity is **not** reduced, only the flow pattern and need for heating and cooling is changed. This type of hood makes the alteration of existing facilities easier due to ease of rebalancing of systems. In many places this type of hood is installed without auxiliary air supply ducts. In this case they use 100% room air and act as a "bypass air flow type" hood. The only advantage of this procedure is that it will allow future addition of auxiliary air supply without buying a new hood. When an auxiliary air supply hood is installed and used as a bypass air flow hood it is important to cap or otherwise close the duct connection. This will prevent dirt and dust accumulations from entering the hood.

d. Glove Boxes and Dry Boxes. Glove boxes and dry boxes present a different ventilation problem. When these facilities are closed and in use they are generally sealed and require little or no exhaust air or makeup air. However, when these are opened ventilation is required in sufficient quantity to prevent fumes, dusts, etc. from flowing into the

room. Generally the access door is small and face velocities of 50 to 100 f.p.m. are sufficient. The exhaust duct connection should be located away from the access door as far as possible. This causes air to flow into the box through the access door and away from the worker. Some dry boxes are of such a type and size that they require a worker to physically enter the dry box at times. Extreme caution should be taken to insure adequate air flow through the entire dry box so pockets of fumes cannot form. Where this type of installation is required special supply and exhaust systems should be installed for this purpose. Their use is intermittent but the volume of exhaust is generally too great to attempt using a fan serving other hoods. Makeup air must also be supplied during this time. Makeup air may not require heating or cooling, but filtering should be accomplished. Dry boxes of this type should be well purged and tested before allowing a worker to enter it. Flexible ductwork may be used to make supply and exhaust connections where permanent connections are not practical. However, if the fumes or vapors, etc. in the dry box are dangerous in any way, provisions for connecting ducts **without** first opening the dry box should be made. Blast gates or valves may be installed for this purpose.

e. California Hoods. California hoods are large hoods which are glass on all four sides and are equipped with sliding doors. From the ventilation standpoint these hoods are similar to the conventional air flow hood with still further disadvantages. It is not practical to exhaust sufficient air to maintain a sufficient face velocity when the hood has more than one open door. The large door openings (on 2 or 4 sides) are more susceptible to drafts and air flow patterns in the room, therefore maintaining the proper face velocity is even more critical. There is no easy solution to ventilation requirements for this type hood. At best certain compromises must be made. This includes the necessity for rigid rules for operation. One solution for balancing makeup air with exhaust air when the hood is closed, and makeup air is being supplied to the room, is to install an automatic or gravity type damper in the exhaust duct. This will allow exhaust air to flow through the hood when it is open but from the room when the hood is closed.

This damper is similar to those used with induced draft fans on boiler installations. It consists of an eccentrically hinged, weighted, damper which responds to pressure differentials.

f. **Walk-In-Hoods.** Walk-in-hoods can fit into any of the air flow characteristics. Some walk-in-hoods have sash that operate vertically while others have sliding doors similar to the California hood except the doors are on one side only. The problems with these hoods are of the same nature as those discussed hereinbefore except that sash or doors are larger. This makes the open face area larger thus requiring more exhaust and makeup air.

g. **Lights and Utilities.** While lighting and utilities are not directly connected to the ventilation problems it is well to mention them at this point. Interior lighting fixtures in hoods must be fume and vapor proof. It is usually a good practice to have lighting explosion proof since it is seldom positively known that explosive or flammable materials will not be used in the hood. Hoods require a variety of utility outlets such as water, compressed air, gas, and hydrogen; drains of various types; sinks and many other facilities. All of these are available. Controls should be located outside the hood sash or doors. Selection of these accessories depends upon the process to be performed.

h. **Local Fans.** Hoods are available with exhaust fans mounted on top or for mounting close-by. The use of this type fan is not generally recommended since the discharge ductwork from the fan is then under a positive pressure. Fumes or vapors may leak out of the ductwork causing problems. If fans must be located in a manner that requires ductwork to be under a positive pressure the ducts should be constructed with welded or soldered longitudinal and transverse joints. These joints should be given an initial leak test and be absolutely tight. Such ducts should also be periodically checked for leaks.

i. **Hoods for Radioactive or Highly Toxic Materials.**

(1) **General.** Ventilation of radioactive and highly toxic processes requires a knowledge of the hazards, the use of proven methods and adequate maintenance including monitoring. Hoods will generally be of one of the types previously discussed. The influence of eddy currents from air supply systems, the care in sizing and locating exhaust connections and the study of air flow patterns within the hood are much more involved than the rule of thumb design efforts for usual laboratory hoods where dilution ventilation greatly contributes to satisfactory control. Radioactive materials furnish the scientist with the most sensitive of all indicators for quantitative or production analysis. In order to rely upon the sensitivity of these materials it is absolutely necessary that no laboratory contamination occurs as a result of the processes employed. Even more important is the protection of the individual from radiation. Many of the materials used are alpha or weak beta emitters. However, material which emits strong gamma rays may also be required in the processes. Proper shielding by the use of leaded enclosures and lead glass is of prime importance. Materials of a radioactive nature in "high level" laboratories are usually handled in glove boxes equipped with remote controls for handling materials.

(2) **Labeling.** A system of labeling of hoods, as discussed in Chapter 8, should be employed to safeguard operating and maintenance personnel.

(3) **Precautions.** The following general list of precautions should be observed in the design and operation of hoods handling radioactive or highly toxic materials.

(a) **Operations** involving radioactive or high toxic materials should be enclosed to the maximum degree possible to reduce contaminated air volumes. The use of glove boxes minimizes air volumes and simplifies air cleaning problems.

(b) **The volume of air** withdrawn from the hood must be greater than the

volume of contaminated gases, fumes or dusts created in the hood.

(c) Where possible, radioactive aerosols should be removed by filtration as close to the hood as practical to prevent unnecessary contamination of ductwork and equipment.

(d) High velocities and cross drafts should be avoided since they tend to increase contamination and dust loading.

(e) Operations involving large amounts of wet digestion and volatilized acid or solvent treatment should be confined to one group of hoods insofar as practical.

(f) A supply of coolant may be necessary in the hood depending upon the flammable nature of the materials or process.

(g) Accessibility to allow decontamination of the hood should be provided.

(h) Face velocities for laboratory hoods should normally be in the range of 125–150 f.p.m. with a minimum face velocity of 100 f.p.m. These velocities are required to insure that no contaminant escapes into the room. Face velocities are minimum values, not average values, and should be maintained at all points of the face opening.

(i) Face velocities of hoods with adjustable fronts should be controlled within reasonable limits in order to reduce the disturbances of airborne materials within the hood. Bypass air flow or auxiliary supply air types of hoods provide this control.

(j) Hoods with high internal heat loads should be adjusted to exhaust the major portion of the air through the top slot.

(k) Where very high quantities of radioactive material or smaller quantities of highly radiotoxic materials are being handled, enclosed glove boxes should be used. An exhaust

volume of 50 to 100 c.f.m. is usually sufficient for glove boxes due to the tight construction of them. The airlocks needed with these hoods should be exhausted if they open directly into the room.

(l) Makeup air supply must be sufficient to balance with exhaust and to distribution of makeup air should be given close attention to eliminate cross drafts. Air flow should be from a clean area to the contaminated area.

(m) The use of prefilters in laboratory hoods for radioactive materials prevents contamination of exhaust ductwork. A gage should be installed to indicate the pressure drop across the filter to aid in determining when filters should be replaced. The type of filter used should be approved by environmental health personnel.

j. Perchloric Acid Hoods. When handling perchloric acid in a laboratory there is a constant danger of explosion. Insurance underwriters recommend that materials used in this type hood be nonporous and inorganic. Any cementing of joints should be solely limited to relatively impervious and inorganic material. The hoods should be designed to reduce to a minimum the turbulence of incoming air. In the design of hoods and ductwork, facilities should be provided for regular washdown procedures. If possible, the fan should be included in the washdown provisions. Perchloric acid hoods **must never** be manifolded into duct systems serving any other hood or equipment. The following is a list of precautions necessary to insure a safe and adequate perchloric acid ventilation hood.

(1) Do not use any other material in a hood designed specifically for perchloric acid. Do not use perchloric acid in a hood designed for other purposes. Identify these hoods and the associated equipment with large warning signs.

(2) The use of a movable sash on the hood opening is **not** recommended.

(3) Provide exhaust ventilation to maintain a hood face velocity of 150 f.p.m.

(4) Locate all utilities outside the hood.

(5) Materials of construction for this type of hood must be inorganic, acid resistant and relatively impervious. Stainless steel, type 316, is preferred. The use of asbestos cement, acid resistant stone-ware and inorganic ceramic coating such as porcelain are acceptable.

(6) Ease of cleaning is paramount using all welded construction for stainless steel with accessible rounded corners and joints or use inert cement for filling stone-ware joints. (Litharge-glycerine or tar are not satisfactory).

(7) The work surface should be water tight with a minimum of 1/2 inch dished front and sides and an integral trough at the rear to collect washdown water.

(8) Construct the hood and ductwork to allow easy visual inspection of hidden surfaces.

k. Laboratory Hood Face Velocities. Recommended face velocities for various types of hoods are given below. Hood face velocities in excess of 150 f.p.m. are likely to cause eddies and should be avoided.

(1) Hoods which handle fumes, vapors or gases which are a nuisance, corrosive or moderately toxic, or which handle tracer quantities of radioisotopes - 100 f.p.m. minimum.

(2) Hoods which handle fumes, vapors or gases which are highly toxic (TLV of 5 p.p.m. or less) or radioactive materials - 100 to 150 f.p.m.

(3) Hoods which handle perchloric acid - 150 f.p.m.

(4) Glove boxes or dry boxes - 50 to 100 c.f.m. per square foot of door opening.

(5) Hoods which handle submicron size dusts - 100 f.p.m. minimum.

(6) Hoods which handle ozone - 100 f.p.m. minimum.

l. Duct Velocities. Duct velocities for conveying gases, fumes, vapors and very fine dusts should be approximately 2,000 f.p.m. Velocities for conveying fine dry dusts should be approximately 3,000 f.p.m.

5. Open Surface Tank Hoods. There are many operations which require the use of tanks with the top open. Operations such as degreasing, plating and dipping are common. Some tanks such as solvent degreasing tanks should be covered when not in use due to the volatile nature of the solvent. Others remain open at all times. Canopy hoods should never be used for an application of this nature since the vapors would be pulled up into the face of a worker. Also canopy type hoods make the use of hoists over such tanks very difficult. Canopy hoods would also limit the height of the working space above the tank. Open surface tank hoods are usually one of two basic types - slotted plenums on the sides exhausting air which is pulled across the tank surface or the push-pull type where air is exhausted by a slotted hood on one side and makeup air is supplied on the other side. Air blown from a small opening retains its directional effect for a considerable distance beyond the plane of the opening. However, if the flow of air through the same opening were reversed so that the same volume of air is being drawn into the opening, the flow of air becomes almost completely non-directional. Due to this phenomenon the effectiveness of slotted exhaust hoods is limited by the width of the tank. Where tank width is such that pure exhaust ventilation is not practical the push-pull type hood may be used. The push-pull hood has the disadvantage, however, of air and vapors being deflected by any object being lowered into or raised from the tank or obstructing free air flow between the supply and exhaust slots. More detailed design data for this type of hood may be found in the publication "Industrial Ventilation" and in the ASHRAE Guide and Data Books.

6. Flexible Branch Hoods. Flexible branch hoods are commonly found in material handling systems and are also used for ventilation of pits or

manholes. Ventilation for pits and manholes generally consist of a system to supply clean fresh air into the pit or manhole which will displace contaminated air. There are some applications where it is desirable to exhaust contaminated air through the system allowing fresh air to enter through other openings. These systems are generally portable and consist of a fan, (filters are optional depending upon application) discharging into or taking suction from a plenum. One or more flexible ducts extend from the plenum to the point of use. Systems should have a diffuser or grille arrangement on the end of the flexible duct and a damper for volume control at the plenum. Material handling flexible branch systems are not portable but consist of a flexible duct connected to the central material handling system and a specially designed hood on the duct intake. These hoods are used where portable hand tools are employed and the operations cannot be confined to a single location. They are often used for welding, grinding and cutting operations. In order to handle the flexible duct and keep it out of the working area a system of weighted or spring compensated and hinged arms is used. The hood on the flexible duct should be designed for the particular operation. These hoods are sometimes arranged with quick clamping devices as a means of being connected to the duct. This allows changing hoods for different operations.

402 EQUIPMENT

1. Air Moving Devices. The air moving device is the heart of any ventilation system. Proper selection and proper operation of this device is essential to satisfactory performance of the entire system. Air moving devices may be one of several types of fans or may be an air ejector. Since fans are the most commonly used air moving device this discussion will be mainly involved with them. More detailed information and characteristic curves can be found in ASHRAE Guide and Data Books. All fans should be A.M.C.A. rated.

a. Fans. Fans can be divided into the following major groupings.

(1) Axial Fans.

(a) Propeller fans. Propeller fans are frequently used for general ventilation and for dilution ventilation.

(i) The disc or bucket blade type is used for moving clean air against no duct resistance.

(ii) The narrow or propeller type blade is used to move air against low static pressures. This type fan is frequently found in exhaust systems for spray booths.

(iii) Tubeaxial type (duct fan) is the same type as the narrow or propeller type except it is installed in a short section of round duct which improves the pressure characteristics. It is well suited for exhausting air containing fumes, pigments and other contaminants which might collect on the blades. Larger fans running at lower speeds will give less trouble where accumulations occur or where abrasion occurs than will a smaller fan running at high speeds.

(b) Vaneaxial Fan. The vaneaxial fan is a tubeaxial fan with guide vanes both upstream and downstream of the blades. It should be used only with clean air.

(2) Centrifugal Fans.

(a) Radial – Blade. The radial or straight blade centrifugal fan is the most commonly used fan for industrial type ventilation. They are used where there is material which is likely to clog the fan wheel. These fans are used for woodworking exhaust, buffing exhaust, and where there is a heavy dust load which must pass through the fan.

(b) Forward Curved–Blade. “Squirrel Cage” or forward curved blade fans are used in systems such as heating, air conditioning and in makeup air units. They are not recommended for exhaust systems handling dusts or fumes that would adhere to the blades and cause unbalance and cleaning problems.

(c) **Backward Inclined Blades.** Backward inclined blade fans should be used only with clean air since the blades are conducive to build-up of material when handling fumes or vapors.

(3) **Power Roof Ventilators.** The centrifugal type does not use a scroll housing but discharges around the periphery of the ventilator and usually in a downward direction, but may be obtained with upblast discharge. If used for exhausting fumes, vapors or dust a downward discharge may have serious deterioration effects on the roofing.

b. **Air Ejectors.** In certain types of installations it is not desirable to have the contaminated air pass through the fan. Corrosive, flammable or sticky materials may affect the fan operation. Ejectors may be used for handling these materials. In some pneumatic conveying or material handling systems it may be advantageous to prevent abrasion and clogging of fans by the use of an ejector. Ejectors are usually very low in efficiency (5 to 12%) and can be used only on low pressure systems (1-1/2 inch static pressure).

c. **Selection of Fans.** Proper selection of a fan for a system requires determination and evaluation of the following items of information:

- (1) Volume required (c.f.m.).
- (2) Static pressure of the system. (Inches of water gage).
- (3) Type of material to be handled through the fan.
 - (a) Fibrous material and heavy dustloading indicates the use of a radial blade fan.
 - (b) Ordinary service indicates a centrifugal type or axial flow depending upon the static pressure and the application.
- (4) If explosive or inflammable material is to be handled it will indicate the use of

spark-proof construction and explosion proof motor if the motor is in the air stream. Standards of the National Board of Fire Underwriters and the National Fire Protection Association should be followed.

(5) Types of drives must be considered. Direct driven exhausters offer a more compact assembly and assure constant fan speed since they eliminate belt slippage. Fan speeds, however, are limited to the available motor speeds. Replacement of a motor is more difficult since a special motor is usually required. Tip speeds of direct driven fans are often high which is conducive to a more noisy fan. Direct drives are normally restricted to small fans. Belt drives offer the advantage of quick and easy change of fan speeds which is important for balancing systems. Standard motors are generally used thus allowing quick and less expensive replacement. This arrangement also makes alterations of a system much easier.

(6) Space limitations and location of the space must be considered. Noise and vibration are important considerations. Either noise or vibration can be a significant nuisance.

(7) Operating temperatures will have an effect on the selection of fan bearings. Sleeve bearings are suitable up to 250°F. Ball bearings are suitable up to 550°F and special cooling devices are required at higher temperatures.

(8) Efficiency of the fan affects first cost as well as motor size and operating cost.

(9) Corrosive contaminants may require the use of special materials of construction or of special coatings.

d. **Parallel Fan Operation.** The use of two fans each separately driven and operating in parallel should be avoided under any conditions. Due to the dip in a centrifugal fan curve and the fact that small variations in speed may occur between the two fans, it is most likely that a "hunting" effect will result. This causes noise, vibration and reduced efficiency. Centrifugal fans are often operated in parallel when mounted on a

common shaft driven by a single motor and the fans are housed together in a single housing so they operate under the same static pressure. Such an arrangement eliminates shifting of motor loads and tends to create a balanced condition. However, an unbalanced condition can occur if the discharge of the two fans are not joined into a single duct or plenum. Separate discharge ducts from dual fans should be avoided.

e. Fan Installation. The following items should be considered when planning a fan installation.

(1) Locate the fan downstream from the dust collector if possible in order to minimize erosion and abrasion on the fan.

(2) Eliminate elbows and other inlet obstructions if at all possible. Sharp elbows at the fan inlet will seriously reduce the volume discharged.

(3) If possible select the discharge and rotation of the fan so that the discharge is in the direction desired, thus eliminating additional bends.

(4) Fans should be located for easy inspection and service.

(5) Spinning flow, experienced by fans exhausting from cyclone collectors, poor inlet boxes and multiple inlet ducts should be avoided. The use of splitters, guide vanes and "egg-crate" straighteners ahead of the fan will help reduce the effect.

2. Motors and Drives.

a. Motors. Where possible, standard motors with open enclosures should be used. These motors are available at a lower first cost. Their use makes replacement easier when it is necessary. Drip or splash proof enclosures should be used where there is any possibility of the motor becoming wet due to weather or wash down. Totally enclosed motors should be used in areas where dust or fumes could enter the motor housing. Explosion-proof

motors should be used where the motor is exposed to explosive or flammable vapors, gases or fumes. In any event standard speed motors are advisable. Motors for direct drive equipment are often specially made even though they have standard electrical characteristics and speeds. Special means for mounting to the driven machine and special shaft sizes and lengths are often used. Replacement of these motors presents problems of stocking motors or prolonged shut down of systems while a replacement motor is obtained. Care should be taken to insure the proper motor size is installed on a piece of equipment. Ampere readings and volt readings should be taken to determine if the motor selection is proper when initial tests are made on a system. These tests should be periodically repeated to insure proper operation. Motors which are overloaded will of course burn out quickly and equipment will not operate properly while running. Motors which are too large needlessly increase first cost and operating cost.

b. Drives. Belt drives are most frequently used on ventilation equipment. The motor sheave for these drives should be of the adjustable pitch type which will allow approximately 20% variation in speed adjustment. The sheave should be selected and sized for proper operation near the midpoint of its adjustment range. V-belt drives should be sized for not less than 150 percent of imposed load. Proper guards should enclose all V-belt drives.

3. Air Cleaning Equipment.

a. General. Air cleaning equipment is available in a wide range of designs to meet the various requirements. This equipment can be divided into two general categories, air filters and dust collectors. Air filters are designed for removal of dusts and air contaminants which are very small in particle size and low in concentration. Sophisticated systems handling highly toxic or radioactive materials in fine particles use filters. Dust collectors are usually designed for much heavier loads. Dust collection equipment is available in a wide variety of designs and principles and vary widely in first cost, operating cost, space requirements, arrangement and materials of construction. Figure

4.4 shows sizes of airborne contaminants. Factors influencing the selection of the dust collecting equipment are:

(1) **Efficiency of Collection Required.** The efficiency or degree of collection is dependent upon the nature of the contaminant, the location of the facility, and local and state laws or codes governing pollution. The salvage value, if any, of the material must be considered. The hazards to health or property and the nuisance characteristics of the contaminants must be examined. When these factors are evaluated a determination of the efficiency required can be made. A safe rule to follow when evaluating the above factors is to select the collection method that will allow the least possible amount of contaminant to escape and still be reasonable in first cost and maintenance as well as meet all Federal, local and state laws and codes governing pollution as required by NASA Handbook NHB 7320.1 "Facilities Engineering Handbook."

(2) **Size and Concentration of Contaminant Particles.** Characteristics of contaminants vary widely. Particle size as well as rate of generation or concentration must be considered.

(3) **Conveying Fluid Characteristics.** The conveying air or gas stream characteristics must be evaluated. High temperature gas streams of 180°F or above preclude the use of standard cotton media in fabric collectors; steam or condensed water vapor will cause plugging of air or dust passages in fabric and dry centrifugal collectors; chemical composition may attack fabric or metal in dry collectors or cause corrosion in wet collectors.

(4) **Contaminant Characteristics.** The nature of the contaminant will have a definite influence on the selection of collectors. Chemical composition may cause attack upon the collector elements or corrosion in wet collectors. Sticky materials can adhere to collector elements and plug the passages. Linty materials will adhere to certain types of collector elements. Abrasive materials in moderate to heavy concentrations will cause rapid wear particularly in dry centrifugal collectors. Particle size and shape may rule out certain collectors. The

combustible nature of the contaminant may dictate the type required.

(5) **Methods of Disposal.** Possible methods of disposing of collected material will vary with the nature of the material, the process involved, hazards presented, and the collector design. Dry collectors can be unloaded continuously or in batches through dump gates or other means. These materials can present a secondary dust problem unless careful thought is given to the disposal methods. Wet collectors can be unloaded continuously or in batches with the material being handled by conveyors or draining as a slurry. The secondary dust problem is eliminated, however disposal and handling of the wet material can present a material handling problem. Solids carry-over in waste-water can also present a problem of sewer or stream pollution if waste water is not properly clarified. The toxicity or radioactivity of the collected material will present a health problem to the worker as well as to the environment. Means of disposal in sealed containers and methods of filling and sealing of these containers must be considered. It is recommended that various equipment manufacturers be interviewed before selecting air cleaning equipment unless sufficient experience in collection of the type being considered is available.

b. **Filters.** Air filters are available in a number of different types, each type having its own capabilities, limitations and application. The selection of the proper filter type is more of an art than a science since clear cut guide lines are not often available. Types available can be categorized as throw-a-way; high or low velocity permanent washable; automatic viscous; automatic semi-dry; replaceable media; electrostatic; and HEPA. Too often filters are based upon a quick judgement and first cost basis, instead of a study of all the requirements, costs, and capabilities. Before the type of filter is selected the engineer should evaluate all of the following:

(1) What are the requirements of the process or area being served? What dust size and concentration is allowable? Are contaminants a health hazard?

(2) What are the dust conditions of the air prior to filtering? What is the maximum probable concentration and particle size which will affect filter loading? Are contaminants hazardous?

(3) How will the variation in static pressure between clean and dirty conditions affect the system? The capacity of some fans can be considerably changed by a slight change in system static pressure.

(4) What are the filter first cost?

(5) What are the maintenance costs? What are the operating costs?

(6) Are pre-filters desirable?

Of these items the first two are probably the most difficult to determine. Where a hazard is present, however, only high or ultra-high efficiency (HEPA) filters should be used. Where radioactive particles are present, only those filters designed and approved for use with radioactive material should be used. These filters must comply with all requirements of the U.S. Atomic Energy Commission. The Oak Ridge National Laboratory publication "Design, Construction, and Testing of High Efficiency Air Filtration Systems for Nuclear Application" should be used for guidance when selecting filters for highly toxic or radioactive material. Filters should be used only where the dust loading does not exceed 4 grains per 1,000 cubic feet of air. This concentration is generally considered non-visible. Loadings above 4 grains per 1,000 cubic feet usually result in a haze or definitely visible concentration. Atmospheric dust in rural, city and most industrial districts usually falls below this concentration. In 1968, the test techniques developed by the U.S. National Bureau of Standards (NBS) and the Air Filter Institute (AFI) were unified with minor changes into a single test procedure, "The ASHRAE Testing Standard for Air Cleaning Devices." In general, the ASHRAE Weight Arrestance Test parallels the AFI test, making use of a very similar test dust. The ASHRAE Atmospheric Dust Spot Efficiency test parallels the AFI and NBS Atmospheric Dust Spot Efficiency test. Values of one of these tests cannot be converted to the other.

A single procedure of testing cannot be applicable to all filters or uses. The ASHRAE Guide and Data Book, Equipment, deals in more depth with tests and filters. High Efficiency Particulate Air filters (HEPA) have an efficiency of, or in excess of 99.97 percent for 0.3 micron particles. This efficiency is determined by the DOP Test according to MIL-STD-282. Table 4.1 which follows is a guide only to aid in filter efficiency selection. Each application should be carefully studied. Another consideration in filter selection is the effect of pressure drop on system operation. It is not uncommon to find a variation in pressure drop as great as 3/4 inch W.G. between initial clean resistance and final dirty resistance of cartridge filters. Since most ventilation systems are of the low pressure type this variation of filter resistance will cause considerable variation in the air quantity moved. Increment filter loading in a maintenance program can reduce this variation. The use of automatic filters or electrostatic filters of the dry agglomerator type will maintain a fairly constant resistance. Maintenance cost is a prime consideration in making filter selection. Realistic labor costs for changing and/or cleaning filters as well as allowance for escalation of labor costs over the life of the system should be considered. Shut down time, length and frequency must be considered. Figure 11-18 in the publication "Industrial Ventilation" presents a comparison of important filter characteristics. Whenever filters are installed a suitable means of determining when the filter should be serviced should be installed. In most cases a manometer or a pressure gage are suitable for this purpose. The use of special filter types for unusual applications must be considered. It has been found that activated charcoal filters are helpful where ozone and some other gases are present.

c. Dust Collector Types.

(1) Electrostatic Precipitators. This type collector is in the high efficiency, high cost category and should not be confused with the electrostatic filter used in many air conditioning systems. The principle of operation is based upon the ability to negatively charge particles in the air stream which causes them to stick to the positively charged or grounded collector plates. Most

TABLE 4.1
GUIDE TO FILTER EFFICIENCY SELECTION

ASHRAE Weight Arrestance Percent	ASHRAE Atmos. Dust Spot Eff. Percent	Typical Applications
85	25	Effective as prefilters, used on some central heating, air conditioning and ventilating systems. Relative ineffective on smoke and staining particles.
90	35	Same as above but with greater effectiveness. Minimum for makeup air for paint spray booths. Somewhat effective on smoke and staining particles.
95	60	Building recirculated and makeup air systems, prefilters to high efficiency types. Effective on finer airborne dusts. Reduce smudge and stain materially. Slightly effect on fume and smoke; ineffective on tobacco smoke.
N.A.	80	Effective on all pollens, majority of particles causing smudge and stain, fumes, coal and oil smoke. Some filter types reasonably effective on bacteria. Partially effective on tobacco smoke.
N.A.	95	Very effective on particles causing smudge and stain, smoke, fumes. Highly effective on bacteria. Suitable for pharmaceutical preparation areas and controlled areas.
N.A.	98	Excellent protection against bacteria, smoke, fumes, and toxic dusts. Filters in this range are usually rated by DOP test method (MIL-STD-282).
—	—	HEPA Filters for radioactive and highly toxic dusts.

precipitators are arranged for horizontal air flow with velocities up to 600 f.p.m. Voltage differentials are in the order of 75,000 volts in most designs. In some units water is used to wash collected material off the collector plates into a collection bin. Generally it is possible to remove collected material from the collection bin without shutting the unit down. The electrostatic precipitator has a very low pressure drop effect on air flow. It is highly efficient and uniform in collection regardless of particle size even of down to sub-micron dusts. The units require considerable space and are high in cost where volumes are less than 50,000 c.f.m. This type unit is frequently used for high temperature gas cleaning such as from furnaces and boilers. They cannot be used where there is danger of explosion or flammable material in the gas.

(2) **Fabric Collectors.** Fabric collectors are in the high efficiency, medium cost category. Their filtering action is based upon the principle of building up a mat of material on the fabric, the mat then acting as the primary filtering media. These collectors do not operate at their top efficiency until they have been in operation for some time. The fabric, which is available in a variety of materials, is arranged in an envelope or stocking configuration. Air must pass through the fabric depositing the contaminant, thus building up a mat on the fabric. Removal or cleaning of the contaminant is usually accomplished by vibrating the fabric or by high pressure air "back flushing." In the less expensive units the collector must be shut down for cleaning. Such a shut down cycle may be necessary after 4 to 6 hours of operation depending upon loading. Shut down would be for a relatively short time but the process (or at least the ventilation for the process) will be shut down. Other designs operate continuously by sectionalizing the collector and cleaning one section at a time. A vertical arrangement of the fabric and a continuous "flushing" action such as a traveling ring blowing high pressure air allows continuous operation. The cleaning action, either by vibrating or by "back flushing" does not remove the entire mat to the point of destroying its efficiency. These collectors are efficient even on sub-micron dust. However, the air or gas being cleaned must be dry enough to prevent condensation or free moisture being

deposited on the fabric. Maximum temperature of the air or gas is a determining factor in the selection of the fabric to be used. Recommended temperatures are: up to 180°F, cotton; up to 200°F, wool; up to 275°F, various synthetics including nylon, orlon, glass cloth and fine metallic mesh; up to 550°F, glass cloth. Equipment cost is increased considerably by the choice of fabric. Static pressure and air flow through this type collector varies with the degree of loading or mat build-up. The removal of dust from the collector may cause a secondary dust problem during the disposal operation. Fabric type collectors generally require a large amount of space which may present a problem in application.

(3) **Dry Centrifugal Collectors.** This type of collector is probably the most frequently used in industry. The principle is based upon the use of centrifugal force to throw a dust particle to the periphery of the air stream where it will be separated from the air stream by impact on the sides or collection plates. This type of collector varies widely in efficiency and design. It will generally fall into the low cost, low maintenance, medium space requirement category.

(a) The cyclone collector is commonly used to collect coarse particles from an air stream such as collection systems for wood working and similar machine shops. It is also used as a pre-collector for a more efficient type of collector where fine and coarse particles are both transported by the air stream.

(b) High efficiency centrifugal collectors have been developed using higher centrifugal forces and velocities. These collectors do not reach the high efficiencies for small particles that is available in electrostatic precipitators or in wet type collectors or fabric collectors.

(c) Dry type dynamic precipitators are in the high efficiency group. This type unit consists of a specially designed fan blade and scroll. The dust passes through the fan and is precipitated by centrifugal force on the fan blades then disposed of through a passage in the scroll

leading to a collection bin. While this type has no static pressure loss the fan is not an efficient air moving device.

(d) Louver type collectors are also available. These units utilize multiple louver blades and rapid and frequent changes in air flow direction causing dust particles to impact on the louver blades. Efficiency increases as the number of louver blades increase and their spacing decreases. Maintenance costs increase as efficiency rises.

(4) Wet Type Collectors. There are many types and designs of wet collectors with efficiencies, first cost, operating cost and maintenance varying widely. Wet collectors have the ability to handle high temperature gases and moisture laden gases. In some cases where explosive or fire hazards exists the dangers may be reduced by the use of this type collector. The secondary dust problem is eliminated by the use of water to wet down the contaminant, however, water introduces other problems. The presence of water can cause or increase corrosion problems and may also require freeze protection in cold climates. The disposal or clarification of contaminated water must be considered in all cases. The quantity of water required for operation may also present a problem. All wet type collectors humidify the air stream passing through them. The effect of discharging air with a high humidity (increased possibility of condensation) on the surrounding structures and area must be considered.

(a) Chamber or spray tower collectors utilize the principle of impaction of dust particles on liquid droplets which are created by the nozzles. These droplets are separated from the air stream by centrifugal force or by impingement on eliminator blades.

(b) Packed towers use the principle of contact beds through which the gases and liquid pass concurrently. This type is widely used for removal of gases, vapors and mists. They will collect particulate matter but are not recommended for this purpose since the particles tend to plug the packing causing extremely high maintenance.

(c) Wet centrifugal collectors are a popular choice. Centrifugal force causes the dust particles to impinge on wetted surfaces. This type as a whole is more efficient than the chamber type, however, they are available in a wide variety of efficiencies and cost.

(5) Unit Collectors. Unit collectors were developed for use in isolated applications or where light intermittent loads occur. Unit collectors discharge the cleaned air back into the space, therefore, their limitations must be understood. Their capacity is usually limited to 200 to 1,000 c.f.m. They are intended for light intermittent loads and have a limited dust holding and storage capacity thus requiring more frequent cleaning and servicing. These collectors will remove particulate matter but do not remove vapors or odors. Their efficiency and the ability to remove fine dust particles should be closely studied since any escapement is discharged into the room. Unit collectors are frequently used for small operations involving grinders, cut-off saws, package filling and similar operations. This type of unit usually employs either air filters or fabric collectors in conjunction with settling chambers or centrifugal action as a means of cleaning. Unit collectors are not suitable for use with processes involving highly toxic materials. Where mildly toxic materials are involved they should only be used after thorough investigation and approval of environmental health and safety personnel. When used in this manner periodic checks of personnel exposed in this area should be made to determine if their health is being affected by exposure to collector discharge. Their cost is low and space requirements are small.

(6) Radioactive and Highly Toxic Materials. There are three major requirements for systems used to collect radioactive or highly toxic materials: 1) Units must be of a high efficiency type due to the extremely low tolerances for the amount and concentration of the effluent. Also the nature of some radioactive material is such that recovery of this material is economically desirable; 2) Low maintenance is of prime importance. When it is realized that the operation of changing the bags in a conventional fabric collector may expend the daily radiation tolerances of 20 or more men, the

importance of low frequency, speed and ease of maintenance is evident. Also low residual build-up of material in the collector is important since excessive quantities increase the radiation levels and reduce allowable working time; 3) The inability to dispose of quantities of radioactive or highly toxic materials by air, water or land presents a problem. These products shall be disposed of as directed in NASA Handbook NHB 7320.1, Facilities Engineering Handbook. The use of dry centrifugal type collectors is not recommended because of lack of efficiency. Fabric collectors using the reverse jet

type cleaning and wool felt media are frequently used. Of the wet type collector designs the orifice type is usually selected for this application. Wet type collectors are used when the temperature or moisture content of the air is high. Water prevents a secondary dust hazard and in some cases may aid in disposal. High voltage electrostatic units are used when the temperature eliminates the use of fabric collectors and the required efficiency is above that of wet collectors. Low voltage electrostatic units require too high a level of maintenance.

Figure 4.1

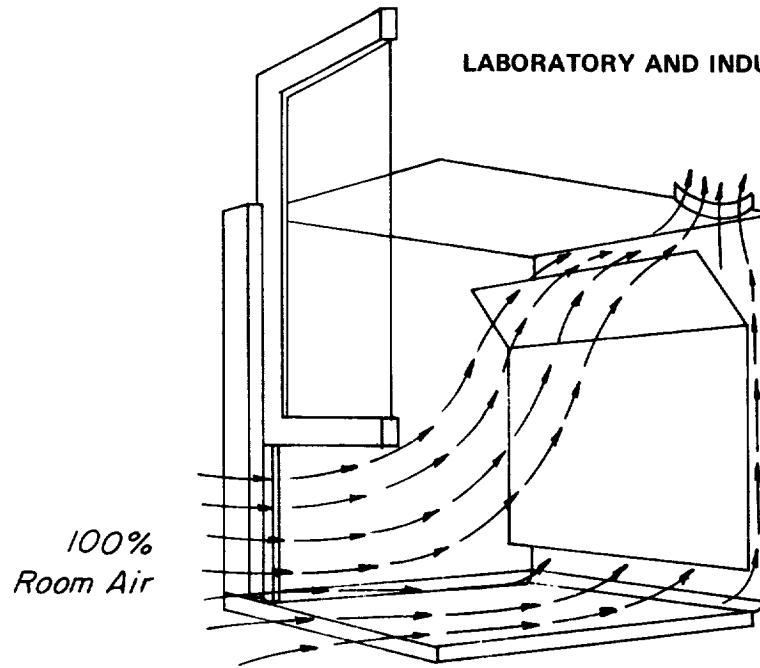

CONVENTIONAL HOOD

Figure 4.1

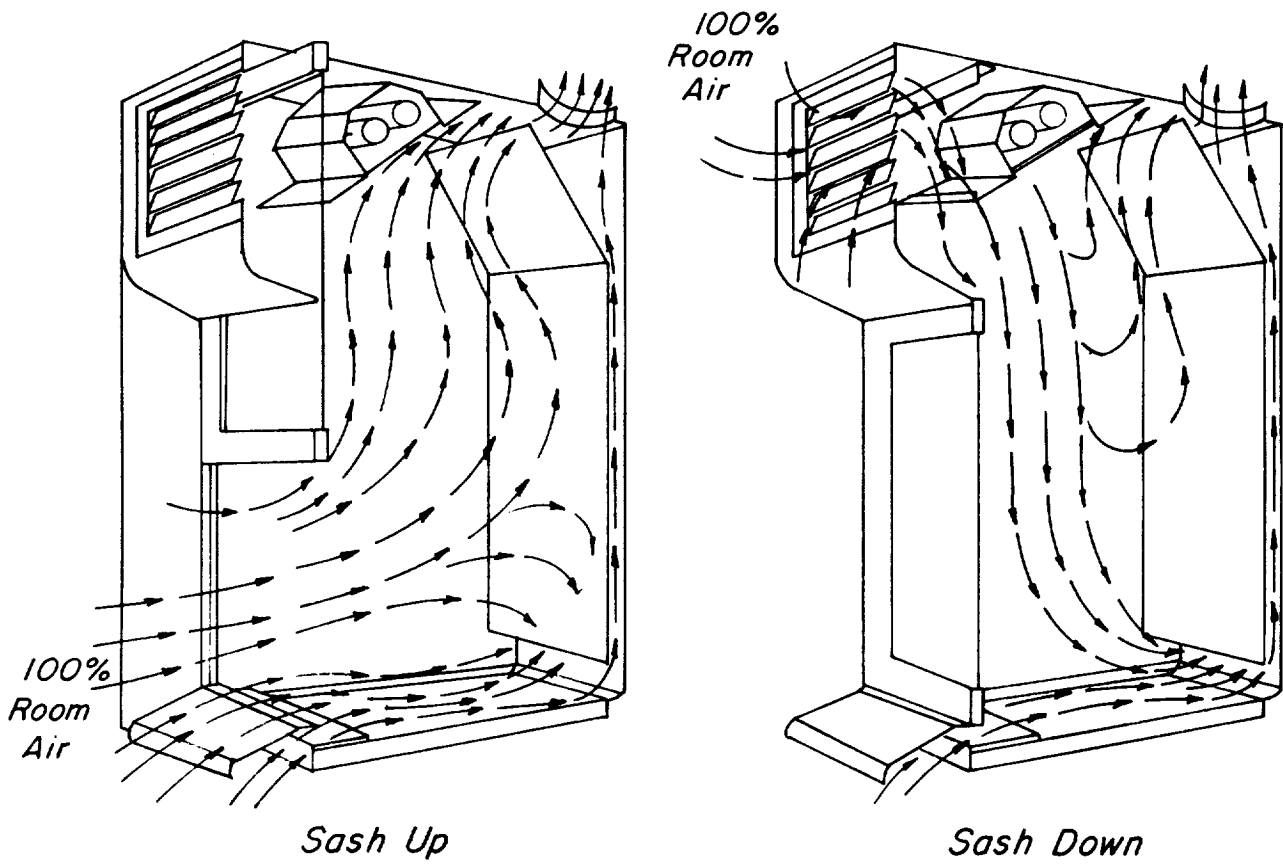

BY-PASS TYPE HOOD

Figure 4.2

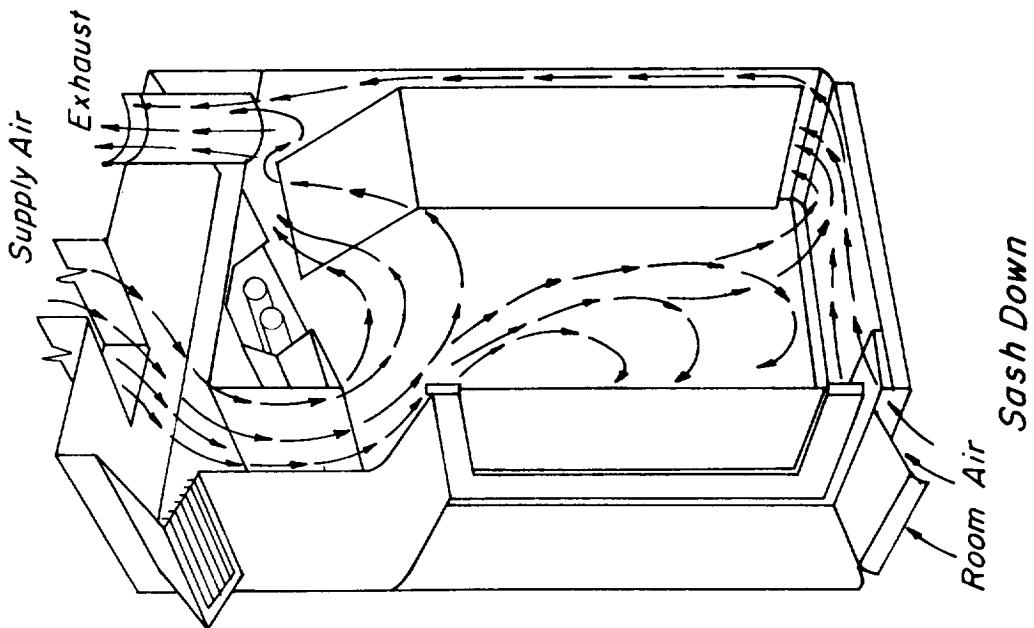
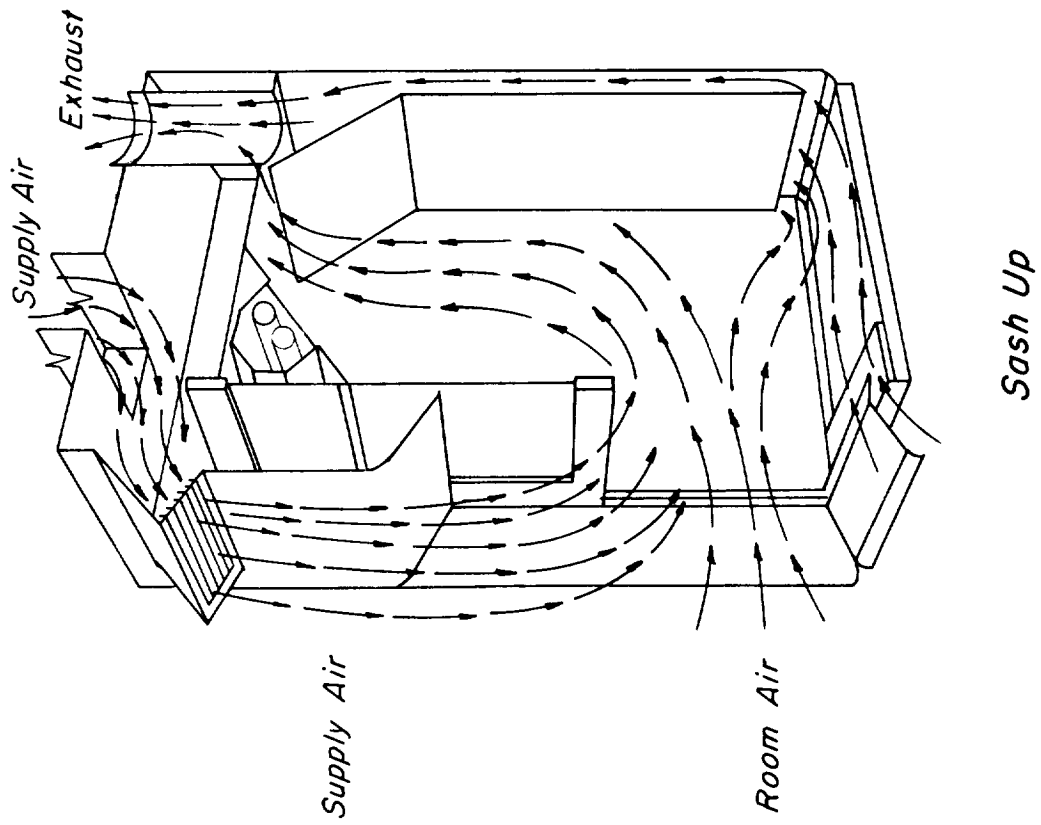

AUXILIARY AIR SUPPLY HOOD

Figure 4.3

Figure 4.4

SIZES OF AIR-BORNE CONTAMINANTS

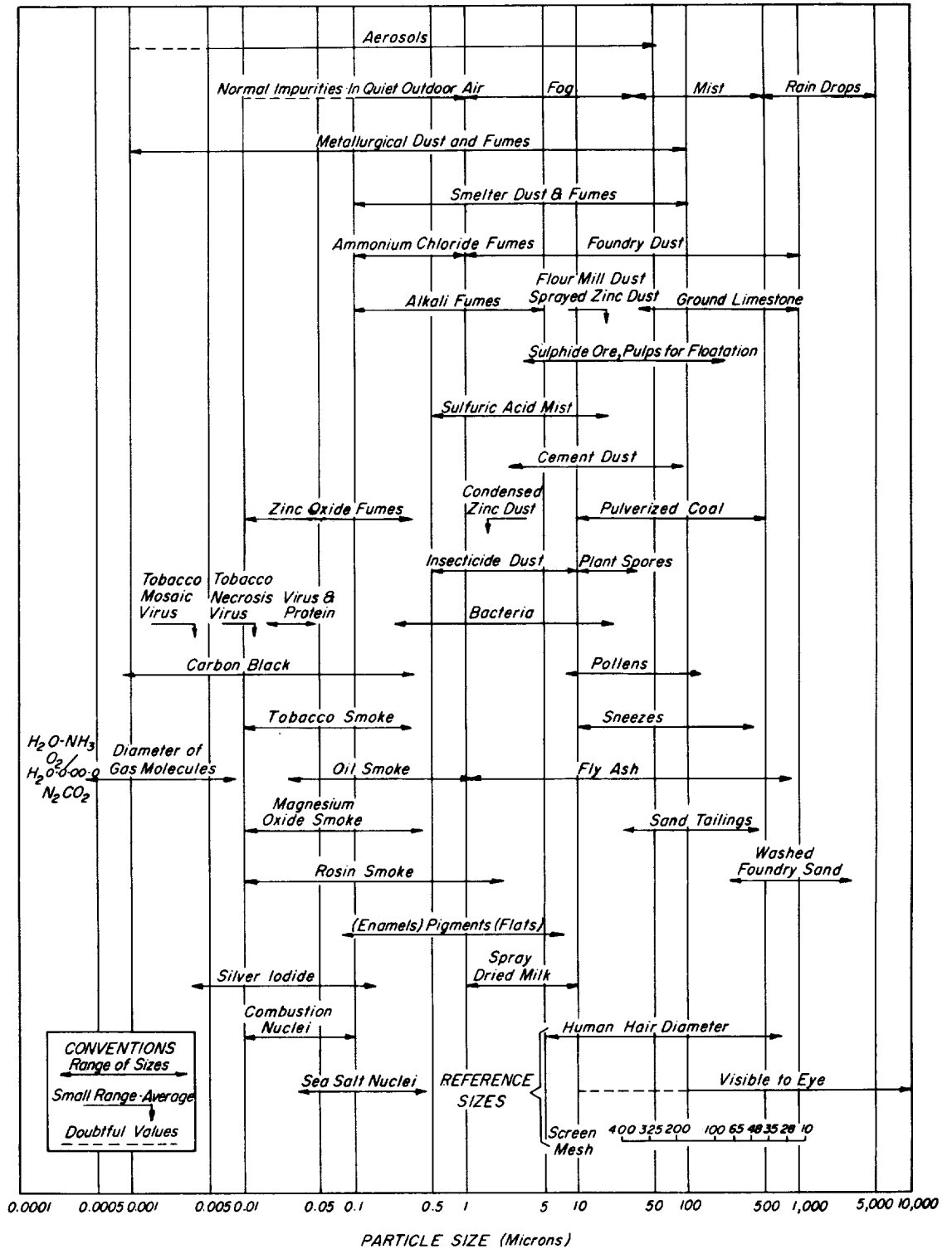

CHAPTER 5: APPLICATIONS

TABLE OF CONTENTS

Paragraph	Page
501 BATTERY ROOMS	5-1
502 PAINT SPRAY BOOTHS	5-1
1. General	5-1
2. Water Wash Type	5-1
3. Paint Arrestor Type	5-1
4. Dry Baffle Type	5-2
5. Exhaust Fans	5-2
6. Makeup Air	5-2
7. Discharge	5-2
8. Operation	5-2
9. Noise Control	5-2
503 WELDING HOODS	5-3
1. General	5-3
2. General Ventilation	5-3
504 MANHOLE OR PIT VENTILATION	5-3
505 VENTILATION FOR RADIOACTIVE AND HIGHLY TOXIC MATERIALS	5-4
1. General	5-4
2. Air Cleaning Facilities	5-4
3. Labeling	5-4
4. Precautions	5-5
506 PERCHLORIC ACID VENTILATION SYSTEMS	5-5
507 VACUUM SYSTEM DISCHARGE	5-5
508 MATERIAL HANDLING SYSTEMS	5-5
1. General	5-5
2. Conventional Duct Systems	5-6
3. Plenum System	5-7
509 SYSTEMS HANDLING FINE DUSTS	5-8
510 VACUUM SWEEPERS	5-8
511 VENTILATED STORAGE FACILITIES	5-9



512	KITCHEN VENTILATION SYSTEMS	5-9
1.	General	5-9
2.	Hoods	5-9
3.	Ductwork	5-9
4.	Fans	5-10
5.	Fire Extinguishing Equipment	5-10
6.	Operation and Maintenance	5-10

CHAPTER 5: APPLICATIONS

501 BATTERY ROOMS

Large banks of electrical storage batteries are frequently used as a standby source of power or for a supply of direct-current (DC) power. Types of batteries that are used may vary but most installations will require ventilation. Modern designs of sealed cells with spray-trap vents practically eliminate the presence of acid spray or mist in the battery room. However, oxygen and hydrogen liberated by a charging current in excess of that utilized for charging the plates, may form an explosive mixture. The rapid diffusion characteristic of hydrogen gas ordinarily prevents any dangerous concentration of this gas. While it is theoretically possible to control charging currents to eliminate this gasing, it has not been found practical. Battery rooms should therefore, be provided with mechanical ventilation. Common practice is to use dilution ventilation for this purpose. These gases are emitted only during the charging cycle. According to National Safety Council data sheet No. 246, hydrogen is emitted at a rate of 0.1474 cubic feet per ampere hour at normal temperature and pressure. The lower explosive limit for hydrogen in air is 4.1 percent. Hydrogen concentration should not exceed one percent by volume in air. A rule of thumb for ventilating battery rooms is to exhaust at the rate of 1 c.f.m. per square foot of floor area. Except for very crowded battery rooms and high charging rates this rule of thumb usually results in concentrations of 0.1 to 0.5 percent concentration. Makeup air must of course be supplied by a satisfactory means. Battery rooms should be maintained under a slight negative pressure as compared to the surrounding areas. This insures infiltration of air from surrounding area rather than exfiltration of contaminated air into cleaner spaces. Batteries operate more efficiently in warm environment than in cold environment. It has been determined that a room temperature of approximately 77°F is best suited for maximum battery efficiency. Therefore, makeup air supplied to the room should be heated during the colder weather. Due to the corrosive nature of acid vapors which may be in the contaminated air, acid resisting materials or acid resisting coatings are normally used in the air passages of the fan. Since the hydrogen gas emitted is of an explosive nature and acid

vapors are of a corrosive nature it is advisable to keep the fan motor out of the air stream. If the motor must be in the air stream, it should be explosion proof. The interior of the exhaust ductwork is sometimes painted with an acid resisting vinyl paint.

502 PAINT SPRAY BOOTHS

1. General. Booths for spray application of paints, varnishes, lacquers, enamels and other flammable materials are commonly used. Hazards are involved in installations of this nature due to the flammability of the materials used and also to the toxicity of these materials. Paint spray booths must comply with the requirements of National Fire Protection Association Pamphlet No. 33 "Spray Finishing". Paint spray booths can be divided into three basic types: Water Wash; Paint Arrestor; Dry Baffle. These types are based upon the method of removal of paint overspray from the air.

2. Water Wash Type. In order to minimize overspray deposits in exhaust ducts and reduce air pollution this type of booth is frequently used. This type of booth utilizes water spray nozzles or perforated pipes in conjunction with a series of baffles in a manner to thoroughly wash the exhaust air. The residue that is separated from the air is carried to a water tank where it is later removed as a sludge. This type of booth is used for medium to heavy loading or capacity. The air velocity normally encountered is 125 f.p.m. over the entire cross section of the booth. For heavy loading or greater painting capacity the velocity is increased to 150 f.p.m. and in extreme cases may be increased to 250 f.p.m. Air flow is horizontal in most booths although some booths employ a down draft where the floor is constructed of a grating and the water tank is extended under the entire grating. This type is particularly adapted to spray painting of large objects.

3. Paint Arrestor Type. This type of booth utilizes filters to remove paint overspray from the air. The arrestor pads or filters should be of fire resistant material and are discarded upon "filling" with paint. Arrestor pads are usually arranged in a vertical bank across the entire end of the spray

booth. Maintenance on this type of booth must be scheduled frequently depending upon the load. This type of booth is suitable for light intermittent loads. Air flow through the booth is normally 125 to 150 f.p.m. over the entire cross section. However there will be a tendency for the arrestor pads to fill in an area directly downstream from the spraying operation, thus causing uneven air flow through the pads and across the area of the booth.

4. Dry Baffle Type. The dry baffle type booth is used for quick drying materials and is the least expensive type. It is used for light painting loads and where high percentage of overspray removal is not required. From the standpoint of efficiency this is the least desirable of the three types of booths. Baffles are arranged in a sloping manner across one end of the booth and overspray is allowed to collect by impact upon these baffles. Some overspray passes through the baffles and may collect on the ductwork or exhaust fan or may be discharged to the outside. Baffles are removable and are replaced or cleaned when required. Air velocities in booths of this type should be approximately 125 f.p.m. but are allowed to drop to 100 f.p.m. and in some cases lower.

5. Exhaust Fans. Exhaust fans are usually of the axial flow propeller type mounted in a round duct which is usually vertical. The fan should be of spark-proof construction with a V-belt drive. Motors must always be mounted out of the air stream regardless of the type of motor. The build-up of paint which would occur on a motor in the air stream would interfere with the cooling of the motor causing it to overheat. The V-belt drive should be fully guarded to protect it from overspray. Fans are always mounted on the clean air side of the paint removal device.

6. Makeup Air. Some spray booths are open to the room in which they are housed. Other booths are closed and use filtered air for makeup. In either case makeup air must be supplied and heated to room temperature during cold weather. The booth (or the room in which it is housed if the booth is open) should be maintained under a slight negative pressure to prevent paint vapors from spreading to other areas. When air is supplied to a

closed booth it is usually supplied through a rack of filters arranged to distribute the air evenly across the entire width of the booth and preferably across the entire height. Ideally the air flow in an empty booth should be "laminar flow". This is not possible when the booth is in use since the object being painted and the operator are in the air stream and cause turbulence.

7. Discharge. The discharge or exhaust from paint spray booths must be carefully located to eliminate fire hazards or damage to the adjacent structures. The nuisance effect of the discharged vapors must be considered. Discharge ducts should be as short as possible extending from the booth to the outside by the most direct route. Air flow instruments should be provided to indicate if the proper amount of air is being moved. In some cases alarms may be advantageous to warn workers should the air flow drop below acceptable levels.

8. Operation. A paint spray booth is a form of hood. Like other ventilating hoods, the closer the hood intake is to the work the more efficient is the operation. The item being painted should therefore be located as close to water baffles, arrestor pad bank or baffles as is practical, and convenient. Paint overspray will have to travel only a short distance before separation in this arrangement. Where makeup air is introduced through a filter rack, air will be given sufficient space to become "laminar flow" insofar as possible. If velocities are too high excessive eddies are formed on the leaving air side of the item being painted. These eddies have been known to disturb the wet paint on the item being painted resulting in an inferior paint job. By locating the item as close to the arrestor as practical, velocities may be reduced, makeup air will be reduced and the quality of work improved.

9. Noise Control. Paint spray booths are often extremely noisy due to high speed fans and due to air turbulence caused by paint build-up on fan blades. Exposure to high noise levels for prolonged periods of time can result in permanent loss of hearing. Where sound levels in paint spray booths exceed 90 dBA exposure should be limited or ear protection provided. New paint spray booths

should have a maximum sound level of 85 dBA when installed.

503 WELDING HOODS

1. General. Ventilation used for welding may be accomplished by several methods. The method selected will depend to a large degree upon the nature of the job, its location, and convenience of the worker. Where it is reasonably possible, a form of local ventilation should be used; such as a booth, a local hood, or a welding bench. Where welding must be accomplished in a number of widely separated locations the use of general ventilation of the space is necessary.

a. Welding Bench. In shops where welding of small assemblies is being performed a welding bench is commonly used. The hood is usually located at the rear of the bench and has two horizontal slots, one above the other, located in the hood face. Air quantities should be 350 c.f.m. per linear foot of hood (or bench, since the hood should extend full length of the bench). The horizontal slots should be sized for an air velocity of 1,000 f.p.m. Air velocity in the hood plenum should not be greater than 1/2 of the slot velocity. Baffles at each end of the bench are helpful to channel air flow across the bench and also to shield fellow workers from the welding arc.

b. Booths. Booths are another commonly encountered method of ventilating a welding area. Air may be exhausted through the rear wall or the ceiling. Air flow should be arranged to carry the contaminated air back away from the worker and should be based on a minimum of 100 c.f.m. per square foot of face opening. The face opening should extend the full width of the booth.

c. Local Hoods. Many shops use a portable local hood connected by flexible duct to an exhaust system. This system utilizes less exhaust air than the other methods since the hood is usually relatively small. Since the connecting ductwork is flexible and portable, the welding operation may be performed at any point the duct and hood will reach. This type system frequently is installed with a system of weighted or spring balanced arms which

support the flexible duct and hold it in the position desired by the worker. Local hoods should be sized for a face velocity of 1,500 f.p.m. and the hood should be provided with flanges on all sides of not less than 3-inch width. Required air quantity varies with the distance the hood is placed from the work. A quantity of 1,000 c.f.m. is sufficient up to a distance of 12 inches between the welding and arc and the hood. This quantity may be reduced to 250 c.f.m. if all welding operations are within 6 inches of the hood face.

2. General Ventilation. Where procedures do not allow the use of hoods, benches or booths, general ventilation should be provided in the area. Minimum air quantities should be based upon the largest welding rod size to be used by each welder. For each welder employed, air quantities should be not less than 1,000 c.f.m. for 5/32-inch diameter rods, 1,500 c.f.m. for 3/16-inch diameter rods, 3,500 c.f.m. for 1/4-inch diameter rods, and 4,500 c.f.m. for 3/8-inch diameter rods. Where toxic materials are involved the air quantities should be increased.

504 MANHOLE OR PIT VENTILATION

Ventilation for a manhole or pit is provided for two reasons. Sufficient fresh air must be provided for maintenance personnel when they are working in the manhole or pit to supply their respiratory needs and to keep them reasonably comfortable. In some pits or manholes, such as steam manholes, ventilation is also provided to relieve heat or steam to protect equipment and to prevent a temperature build-up which will heat the ground to such an extent that grass and other vegetation cannot live. Ventilation methods may be portable or permanent. Portable manhole ventilation systems are usually used to supply respiratory requirements and aid comfort conditions for workers. Such systems usually consist of a centrifugal fan discharging into a plenum and flexible ducts extending from the plenum. Volume or shut-off dampers may be provided for each duct connection to the plenum if desired. Fan intakes may be screened to act as insect or bird screens and a safety guard, or may be provided with filters if desired. Most portable type fans are driven by

gasoline engines. Care must be taken in locating engine exhaust with respect to fan intake to avoid blowing exhaust gases into the manhole or pit. By supplying air directly into the manhole or pit it will displace any contaminated air or gases which have accumulated and may also be directed as desired by the worker. This procedure can be reversed to exhaust from the bottom of the manhole if desired or if the presence of undesirable gases or fumes is a known factor. Exhausting from the manhole does not provide effective comfort ventilation. Where permanent ventilation is provided it should consist of two ducts. One duct should extend to the bottom of the manhole and the other should terminate near the top. Both ducts should be provided with a gooseneck or weather cap above ground and should extend above any flood level which can be predicted. Ducts should preferably be located on opposite sides of the manhole or pit. Ventilation is obtained normally by gravity. The top of the pit can be made removable and can provide permanent ventilation. This type of pit cover is shown in Figure No. 5.1. Pits of this type are frequently used for steam or hot water distribution system. The removable top aids maintenance personnel. Before allowing personnel to enter deep pits, manholes or spaces where danger of accumulation of toxic or explosive gases exists, or where oxygen may be insufficient, the air should be tested. Procedures should be developed to require such testing before entry by work crews and maintenance personnel. Adequate instruments for testing should be available at all facilities.

505 VENTILATION FOR RADIOACTIVE AND HIGHLY TOXIC MATERIALS

1. General. Ventilation of radioactive and highly toxic processes requires a knowledge of the hazards, the use of proven methods and adequate maintenance, including monitoring. The entire system must operate as a coordinated unit. Where radioactive material is handled, proper radiation shielding must be provided as prescribed by AEC regulations. The requirements for cleaning of the polluted air or gas discharge will vary with the operation being conducted and in most cases the requirement will be considerably more rigid than required for normal industrial processes. Hood

details are covered in Chapter 4. The influence of eddy currents from air supply systems, the care in sizing and locating exhaust connections, the study of air flow patterns within the hood and the cleaning of exhaust gases are much more involved than the rule of thumb design efforts for usual laboratory ventilation.

2. Air Cleaning Facilities. Careful design is mandatory for makeup air exhaust systems and the selection of air cleaning equipment. Cleaning requirements for makeup air or supply air are often of a high order of efficiency. Exhaust air cleaning generally requires the use of high efficiency collectors, or filters backed up by HEPA or ultra-high efficiency designs. Wet dust collectors in place of inexpensive air filters may store material more safely and make contamination of an area less likely. However, the disposal system for the water used must be carefully considered. Reverse jet fabric arrestors may be warranted in place of the less expensive conventional fabric collectors since there is less area of air seals to leak and fewer elements to be replaced. Prefilters installed ahead of expensive HEPA filters are recommended to reduce the replacement cycle for HEPA filters, reducing handling, waste disposal and contamination problems. The exposure of maintenance personnel to the hazards of servicing and replacing air cleaning elements usually justifies the more expensive equipment. Where systems are handling radioactive or highly toxic materials, consideration should be given to having quality assurance testing of HEPA filters performed by an Atomic Energy Commission (AEC) Quality Assurance Station. This testing service is available through Filter Unit and Testing Service, U.S. Atomic Energy Commission. Quality assurance testing does not take the place of tests made by the manufacturer or of "in place" testing. These tests may be used as an acceptance test for HEPA filters and are "go" - "no go" type tests with no filter repair. The quality assurance testing is a check on the manufacturer and on shipping procedures and damage.

3. Labeling. A system of labeling of hoods, ducts, fans, air cleaning equipment and discharge openings should be employed to safeguard operating and maintenance personnel. Labeling of

any hazardous discharge, even though the air or gas has been processed through air cleaning equipment, should be conspicuous. Such discharges should be located and arranged in a manner to preclude possible injury to unsuspecting personnel who pass in the vicinity of the discharge.

4. Precautions. The following general list of precautions should be observed in the design and operation of systems handling radioactive or highly toxic materials. These precautions are in addition to those stated hereinbefore in Chapter 4.

a. The value of waste materials such as chips may be such that reclaiming facilities are warranted.

b. Accessibility to allow decontamination of the hood, ductwork and other items of equipment must be provided. Accessibility for servicing or replacement of air cleaning equipment is an absolute requirement.

c. The fan should be located in a manner to insure that all ductwork within the building will be under a negative pressure.

d. Filtration of makeup air is necessary to reduce airborne dust concentrations and thus increase the life of the high efficiency exhaust filters.

e. Where there is a possibility of spontaneous or continuous release of toxic materials, or where several hoods are connected to a single exhaust system, the exhaust fan should be operated continuously. Standby fan capacity should be considered to take over in case of breakdowns and during maintenance periods.

506 PERCHLORIC ACID VENTILATION SYSTEMS

Systems that handle perchloric acid are highly dangerous. Chapter 4 gives a list of precautions to be taken in this type facility. It is important that washdown procedures be developed and performed regularly and thoroughly. Exhaust ductwork should be kept as short and straight as possible and isolated

from all other exhaust systems. Horizontal runs of ductwork, manifolds and sharp turns should be avoided. The exhaust fan should handle this system only and should be constructed of acid resistant metals or protected by an inorganic coating. Air ejectors may be used. The fan should be lubricated with a fluorocarbon type grease. High efficiency water-type collectors are often installed as close to the hood as possible to minimize the accumulation of perchloric acid in the exhaust duct. The exhaust duct should terminate outside using a vertical discharge cap which extends well above the roof eddy zone.

507 VACUUM SYSTEM DISCHARGE

Vacuum systems are not generally considered ventilation systems. The technical aspects of design, operation and maintenance of vacuum systems can be very complex depending upon the degree of vacuum to be obtained. Vacuum pumps are available in many designs varying in method of operation and capacity. These vacuum systems do remove air, gases and vapors from a given chamber and in this respect only are they similar to ventilation systems. Since gases or vapors discharged by the vacuum system may be toxic, flammable or explosive, they must be coordinated with the ventilation systems. Discharges from vacuum systems should be located in a manner that will prevent the influence of air intakes from capturing the discharged gases or vapors. Prevailing winds should be considered. Most vacuum pumps discharge an oil mist mixed with the discharge gases. Discharge piping is frequently terminated in a gooseneck above the roof. If an oil separator is not used, this arrangement is apt to deposit a pool of oil on the roofing thus producing a fire hazard as well as deterioration to the roofing. Vacuum systems should never discharge on the inside of a building or under a window which may be opened.

508 MATERIAL HANDLING SYSTEMS

1. General. Material handling systems are discussed in Chapter 3 and hoods, fans and air cleaning equipment in Chapter 4. However, the selection of the type of duct system and method of design and operation have not been previously

covered. Detailed design procedures for the following types of duct systems can be found in the publication "Industrial Ventilation".

2. Conventional Duct Systems. Conventional duct systems, with branch ducts from each hood connecting to a main duct which is graduated in size, can be designed by two methods. The method of design selected will have a definite effect upon the method of operation and future use of the system. The methods are "Design Without Blast-Gate Adjustment" and "Design Utilizing Blast-Gate Adjustment". A complex material handling system is actually a group of simple exhaust systems connected to a common main duct. This type of system is necessary in order to distribute air flow between the various branches. Air will always take the path of least resistance. If the design does not provide for proper distribution, a natural balance of the air will occur. The air volume will distribute itself automatically according to resistance of the available flow paths so that the resistance through each path to the fan is equal. This distribution of air flow will not be correct insofar as volume is concerned (or velocity) unless the designer provides a means of obtaining the desired distribution with balanced resistance.

a. Air Balance Without Blast-Gate Adjustment. This method of design provides a balanced air distribution without the use of blast-gates and is often referred to as "static pressure balance method". The calculations for sizing ducts begins with the branch of greatest resistance and proceeds, branch to main, and section of main to section of main until it reaches the fan. At each point where two air streams meet, the static pressure necessary to achieve desired air flow in one stream must match the static pressure in the adjoining air stream. (This is the condition prevailing in any operating system whether air flow volume is as desired or not). Matching of the static pressure of the two air flow paths and the desired air flow volume is obtained by the proper selection of duct sizes and careful attention to design of all elbows and other duct fittings.

b. Air Balance Utilizing Blast-Gate Adjustment. This system of design relies upon the

use and adjustment of blast-gates or dampers to achieve the desired air flow in each branch. These blast-gates or dampers provide an adjustable means of imposing resistance in each branch. Design calculations, as in the previous method, begins at the branch of greatest resistance and the pressure drops calculated through the branch and through the various sections of the main duct to the fan. At each point where two air streams meet the desired volumes are added together and the duct is sized for this volume maintaining the required minimum velocity. No attempt is made to balance the static pressure in the two adjoining ducts. Choosing the branch with the highest resistance is of prime importance. If an error is made in this choice any branch with a resistance higher than the one chosen will not have the desired capacity even though the blast-gate is wide open. Therefore, a check of the resistance of all branches is essential.

c. Choice of Methods. In designing systems which will handle highly toxic materials the choice of designing without blast-gates eliminates the possibility of gate setting being tampered with by unauthorized personnel thus creating a hazard. Where systems will handle explosives, magnesium and radioactive materials; design without blast-gates is mandatory to eliminate the possibility of accumulation of material at blast-gates.

(1) Without Blast Gates. The following is a listing of merits and limitations of designing a system without blast-gate.

(a) Air volume cannot easily be changed.

(b) Flexibility is limited for alterations or future additions.

(c) Ductwork is normally constructed in sizes varying in increments of inches (3", 4", 5", 6", 8", etc.). In order to balance static pressure, ducts must be accurately sized and constructed and may be in odd sizes (3-1/2", 4-3/4", 7-1/4", 8-1/2", etc.).

(d) Choice of duct volumes cannot be changed. Where new or unknown

operation is involved the volume chosen may be incorrect.

(e) No unusual accumulation problems exist.

(f) Ductwork will not clog if velocities are chosen wisely.

(g) Where branches vary greatly in length, the velocity in the shorter branch must be considerably higher than in the long branch in order to balance static pressure. This higher velocity may create excessive noise or may cause increased wear of the duct if abrasive material is being transported.

(h) Design calculations must be very accurate and are time consuming.

(i) Total air volume may be slightly greater than design air volume due to added air handled to achieve balance.

(j) Incorrect choice of "branch with highest resistance" will show up in calculations.

(k) Layout of system must be in complete detail with all obstructions cleared and length of runs accurately determined. Installations must **exactly** follow layout.

(l) Operation of the system must be as conceived by the designer with strict controls to prevent tampering.

(m) Bent hoods or ducts will alter system operation.

(2) **With Blast Gates.** The following is a list of merits and limitations of systems designed for utilizing blast-gate adjustment.

(a) Air volume may be changed very easily either intentionally or by tampering.

(b) The system is reasonably flexible, allowing alterations and additions.

(c) Correction of improperly estimated flow volumes is easily accomplished.

(d) Partially closed blast-gates may cause erosion to slides and accumulation of material in the ducts. Accumulation of sticky or stringy materials present a build-up problem.

(e) Ductwork may plug if blast-gate adjustment is incorrect.

(f) Design calculations are relatively brief.

(g) Balance may be achieved with design air volume.

(h) Poor choice of "branch with greatest resistance" may be undiscovered causing the branches with greater resistance to be starved for air.

(i) Standard duct sizes may be used.

(j) Leeway is allowed for moderate variations in duct location to miss obstructions not known in design.

(k) Blast-gate adjustment can usually compensate for bent or damaged duct or hood.

3. Plenum System. Plenum type exhaust systems vary from the conventional type in that the main duct of a plenum system is a large, oversized duct usually of the same size from end to end. Air velocity in the plenum is low, allowing larger particles to settle out on the bottom of the plenum. The required material handling velocities are maintained only in the branch ducts. Cleaning equipment and the exhaust fan may connect to the plenum at any point from one end to the other. Various means of cleaning the plenum can be employed. Clean-out doors must be located at frequent intervals. Conveyors of the belt type or drag chain type or high velocity duct conveyor may be used as a cleaning method and may be continuous or intermittent. The following is a list of merits and limitations of the plenum system.

a. Branch ducts can be added, removed, or relocated at any convenient point along the main duct.

b. Branch ducts can be closed off and the air volume in the entire system reduced as long as minimum transport velocities are maintained in the remaining branches.

c. The main duct can act as a primary air cleaning device for large particles thereby reducing the load on the actual air cleaning equipment.

d. Reduced static pressure in the main duct may allow the use of a smaller fan motor.

e. Sticky, linty materials tend to clog the main duct.

f. Materials subject to direct or spontaneous combustion must be handled with care. Wood dust has been successfully handled; buffing dust and lint are not easily handled and are not recommended. Explosive dusts such as magnesium and titanium should not be handled in systems of this type.

g. The cost of this system is higher than a conventional system due to the cleaning equipment for the plenum and the size of the plenum as compared to ductwork.

509 SYSTEMS HANDLING FINE DUSTS

Material handling systems employed where fine dusts are present should receive special attention. Fine airborne dusts travel with air currents and diffuse readily, finding their way into cracks and corners and settling out wherever air velocity is low. Most dusts, as a minimum, have a nuisance factor, but many present very definite hazards. Many dusts present health hazards by entering the body through the respiratory tract. Of these, beryllium is one of the most dangerous although a number of others can cause serious illness. Other dusts enter the body through the skin causing inflammation and eruptions. Some may cause serious illness by entering through the digestive tract. Fire and explosions are frequent hazards due to dust, and

listed below are a few of the dusts in these categories:

- Antimony – Flammable
- Aluminum – Explosive
- Arsenic Compounds – Flammable
- Barium – Explosive
- Chloride of Lime – Explosive
- Magnesium – Explosive
- Phosphorus – Explosive
- Tetryl (Trinitrophenyl methylnitramine) – Explosive
- Titanium – Explosive
- Uranium – Pyrophoric

Fans in systems handling dusts should be of spark-proof construction. Motors should be out of the dust-laden atmosphere and preferably explosion proof. Air cleaning equipment must be carefully selected. High efficiency filters are often used for fine dusts, but their capacity is limited. Electrostatic precipitators are highly efficient but must not be used where flammable or explosive dusts are present. High efficiency wet type collectors are often used to reduce fire and explosive hazards. Secondary dust hazards must be considered. This is a particular hazard to maintenance personnel. Where fine dusts are collected in a dry state operating procedures should be formulated and enforced as to the method of disposal of the dust. Maintenance personnel should be provided with protective clothing and respiratory masks as required for their protection. Care must be taken to prevent dusts from re-entering the air stream or atmosphere while removing dust from the air cleaning device and in subsequent disposal. Provisions of NFPA publication No. 91, "Blower and Exhaust Systems," should be followed in all systems that handle dusts. Particular attention should be given to the requirements for explosion relief venting. Other NEPA standards are available on handling of combustible solids, dusts and explosives. Many of these pertain to the particular material being handled.

510 VACUUM SWEEPERS

Where buildings house laboratory or industrial ventilation which is employed in handling toxic, radioactive or other fine dusts; proper clean-up

equipment should be provided. Some fine dusts escape even the best ventilation systems. This dust will settle out in the rooms and corridors of the building. Clean-up personnel should be provided with a portable vacuum sweeper equipped with HEPA filters. These sweepers are commercially available. They are available mounted on wheels or a cart. Since dusts settle on floors and work tables, cabinet tops, etc., a definite clean-up procedure should be established. Workers in the area as well as clean-up crews should be kept familiar with clean-up policies. Certain materials and areas should be cleaned up by workers familiar with the material qualities and their proper handling, while other areas may be left to normal daily clean-up. Preparation of policies must be a joint effort of maintenance personnel and operating personnel.

511 VENTILATED STORAGE FACILITIES

There is a tendency in some laboratories to use fume hoods for chemical storage. This practice should be prohibited since a build-up of containers can obstruct the proper air flow and prevent proper clean-up. Ventilated storage cabinets should be provided for this purpose. Cabinets with holes or slots in the front or sides and connected to a ventilating fan is best for this purpose. In some cases it may be practical to connect such a cabinet to a fan serving a laboratory fume hood. However, the same precautions are necessary as in a central system where one fan handles two or more hoods. Mixtures of vapors or fumes from the hood and the cabinet can be dangerous. There are also some laboratories which utilize bottled gases. These bottles should be installed with ventilated hoods or cabinets or other ventilated spaces. Where bottles are connected with a single hood the same fan is frequently used for bottle cabinet or hood ventilation. Cabinets for chemical storage should be provided with velocities of 75 f.p.m. minimum through the openings and an air quantity sufficient to produce 30 air changes per hour within the cabinet when it is closed. Sufficient paths for air passage must be provided to prevent dead areas. Hoods over bottles should have face velocities of 80 to 100 f.p.m. Fans serving ventilated storage cabinets or hoods over gas bottles should operate

continuously – 24 hours a day. This requirement may preclude the use of a fan serving an adjacent laboratory hood.

512 KITCHEN VENTILATION SYSTEMS

1. General. Ventilation is the chief means used for removing kitchen heat, odors, smoke and airborne grease, and for preventing them from entering the dining area. All cooking facilities should be provided with hoods and mechanical exhaust systems. Commercial-type dishwashing facilities should be hooded with mechanical exhaust systems. Hoods over cooking equipment should comply with requirements of NFPA Standard No. 96.

2. Hoods. Design data for hoods over kitchen equipment can be found in the ASHRAE Guide and Data Books, the publication "Industrial Ventilation," or NFPA Standard No. 96. Face velocities for range hoods should be in the range of 75 to 100 f.p.m. Makeup air is often drawn from the dining area. Kitchens should be kept under a negative pressure to prevent heat, odors and smoke from spreading into the dining area. Hoods over cooking equipment should be equipped with approved grease filters installed on an incline of not less than 45° from the horizontal and with a drip tray below the lower edge of the filters.

3. Ductwork. Ductwork from cooking equipment should be suitable for handling air at 600°F and constructed of steel not lighter than 16 gage or stainless steel not lighter than 18 gage. Particular attention should be given to routing ducts in accordance with NFPA Standard No. 96. Termination of discharge ducts should be vertical if possible with clearances as required by NFPA Standard No. 96. All ductwork should be provided with access doors or panels at all changes in direction. Horizontal ducts should have access doors or panels at intervals not exceeding 20 feet. Access doors or panels should be located and sized to allow easy cleaning of ducts. All ductwork from kitchen equipment is subject to condensation, and provisions should be made for draining. Dampers should be kept to a minimum.

4. Fans. Exhaust fans and motors should be approved and rated for continuous operation. All wiring and electrical equipment should comply with NFPA Standard No. 70 (the National Electric Code). Where exhaust fans are mounted on the roof they should discharge vertically upward if possible. Downward discharge should not be used. Fan construction should be such that bearings are out of the airstream and access should be provided to allow cleaning. When the fan is not visible from the kitchen area a signal light should be installed to indicate fan operation. Consideration should be given to the use of a timer to continue fan operation for a period of two hours after cooking equipment is turned off to allow fat fryers and other appliances to cool.

5. Fire Extinguishing Equipment. NFPA Standard No. 96 requires both automatic fixed pipe

extinguishing system and portable extinguishers for Class B fires for hoods over cooking equipment. Serious consideration should be given to the installation of a fixed pipe system in the ductwork. Steam quenching systems are recommended since they are effective, require less maintenance than other types and cause slight damage when used. Automatic CO₂ systems or water sprinklers may be used. Fixed systems should be automatic but provided with emergency manual means of operation.

6. Operation and Maintenance. Operation and maintenance procedures should be developed and posted in the kitchen area. Procedures should conform to requirements of NFPA Standard No. 96 and Appendix C thereto.

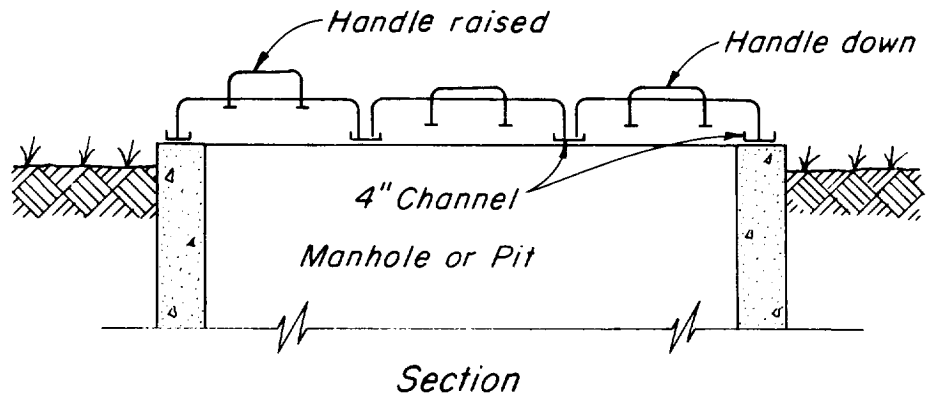
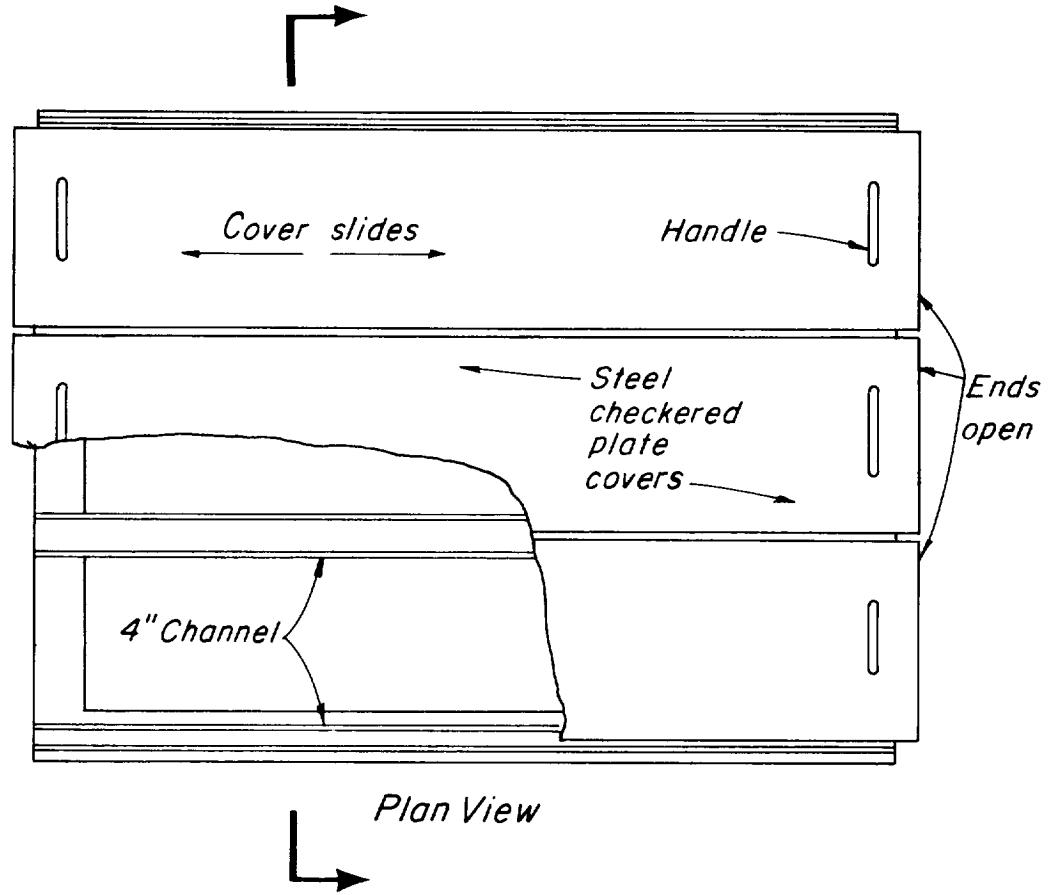

MANHOLE OR PIT COVER

Figure 5.1

CHAPTER 6: DESIGN

TABLE OF CONTENTS

Paragraph	Page
601 CRITERIA	6-1
1. General	6-1
2. Hazards	6-1
3. Maintenance and Flexibility	6-1
4. Fire Protection	6-1
5. Noise Levels	6-1
6. Systems Operation	6-1
602 SELECTION OF EQUIPMENT	6-2
603 MAKEUP AIR	6-1
1. General	6-2
2. Building System	6-2
604 INTAKES AND EXHAUSTS	6-3
1. General	6-3
2. Intakes	6-3
3. Exhausts	6-3
605 CAPTURE AND TRANSPORT VELOCITIES	6-4
606 MATERIALS OF CONSTRUCTION	6-4
607 CONTROLS AND INSTRUMENTATION	6-4
1. Controls	6-4
2. Instrumentation	6-4
608 POLLUTION CONTROLS	6-5
609 DUCT AND EQUIPMENT IDENTIFICATION	6-5
610 FLOW DIAGRAMS	6-5
611 SYSTEM TESTING AND BALANCING	6-6
612 MISCELLANEOUS ITEMS	6-6





CHAPTER 6: DESIGN

601 CRITERIA

1. General. Establishing criteria for a new facility is the first step in design. Frequently criteria is established by planning personnel with the assistance of supervisory personnel who will be connected with the operations to be performed in the completed facility. Too often the engineering personnel and the environmental health and safety personnel are not fully consulted. Such an oversight frequently leads to the establishment of unrealistic or excessively expensive heating, air conditioning and ventilating criteria. A form of "systems approach" must be considered. A basic understanding of the processes involved to produce environmental conditions and the relative cost of these processes is essential if good criteria is to be established. In short a realistic approach to environmental conditions must be taken but safety must not be compromised. The criteria established must state the requirements for temperature, humidity, exhaust, makeup air, cleanliness of air and the need for positive or negative pressures or air flow patterns in special cases.

2. Hazards. In determining the various conditions a study must be made of the hazards involved in the facility and the necessary protective measures that must be taken. A complete check of regulations, codes and local ordinances should be made. The hazards involved may be a determining factor in the location of the facility. In the case of highly explosive type operations this is evident. Exhaust emissions may be detrimental to persons passing by on the street or to adjacent facilities or surrounding areas. Noise may be an important deciding factor. Dirt, dust or blowing sand may affect the orientation of the facility or make treatment of the surrounding area necessary. The use of highly toxic, radioactive, explosive or flammable materials in the operations will have a heavy impact on ventilation requirements. Determination of which exhaust hoods may be connected to a central system and which must be single systems, must be made. Chapter 3 contains a discussion of this problem.

3. Maintenance and Flexibility. All facilities must be maintained. Many will require future

alterations to meet the changing requirements of today's technology. Access to mechanical equipment such as fans, filters, coils, and compressors is essential and is normally provided. However, thought must be given to providing access to ductwork, duct drains, local filters and roof mounted equipment. Space above building ceilings is often so crowded with ductwork, electrical conduit, and piping that future alterations are extremely difficult and expensive. It is often more economical to increase the floor to floor height of a building to allow room for simple straight installation of the various utilities than it is to crowd these utilities into small spaces. Laboratory type buildings should be planned with large chases between laboratories in which ductwork, filters, piping and other utilities can be located and will be accessible.

4. Fire Protection. Fire protection equipment to be installed in conjunction with a ventilating system should be determined in the early stages of criteria development. Safety personnel and those personnel having jurisdiction of fire protection systems for the facility should be consulted. N.F.P.A. standards should be followed in all cases. Consideration should be given to installation of sprinkler and wash down systems, carbon dioxide (CO₂), dry chemical, foam or other permanent type fire extinguishing systems to be installed in conjunction with the ventilation systems. Fire detection systems should be considered. Corrosive effects of gases, fumes and vapors must be considered in selection of systems. Special attention should be given to control of makeup air and exhaust systems in event of fire to control removal of smoke. The use of access doors for cleaning of ductwork should not be overlooked. The need for fire dampers as required by N.F.P.A. standards and consistent with construction of the facility should be determined. Suitable construction material criteria should be established to include which items of equipment should be explosion proof construction, fire resistant or fire retardant.

5. Noise Levels. Criteria should be developed for maximum noise levels allowable by ventilation systems. This criteria will have a limiting effect on duct air velocities, equipment operating speeds and selection of air diffusers and grilles.

Therefore, a realistic approach should be taken to prevent this criteria from unnecessarily increasing the project cost. The effect of noise on the personnel who will occupy the facility should be fully considered.

6. Systems Operation. After studying and evaluating the above points of consideration it is then necessary to formulate a method of systems operation to determine the types of systems to be used. Criteria should then be stated clearly so the design engineer will know and understand the requirements.

602 SELECTION OF EQUIPMENT

Using the criteria for a new facility a plan of the ventilating systems can be formulated. Ventilation systems, including makeup air, must be coordinated with other heating and air conditioning systems. A thorough check of codes, regulations and local ordinances should be made. Compliance with such codes, regulations and ordinances should be in accordance with NASA Handbook NHB 7320.1 "Facilities Engineering Handbook." Flow diagrams of all the air handling systems should then be formulated showing all desired air flow patterns and positive or negative pressure areas desired. Calculations can then be made to determine air quantities of both exhaust and makeup air. The flow diagrams can then be completed so air quantities balance. It should be kept in mind that air quantities for hoods cannot be determined until the hood type, characteristics and dimensions are fixed. Ventilation equipment selection can then be made from catalog data of manufacturers. Each item should be selected to determine the type of equipment, its availability, dimensions, capacities, motor horsepower and electrical characteristics. Actual selection from several manufacturers' catalogs will insure that the equipment is available in the type and capacity applicable. The use of unproven new types of equipment is often risky. Where the use of this type equipment is desirable the availability of parts and service should be carefully considered. Where such equipment is manufactured by only one or two manufacturers the economic stability of those manufacturers should be considered. Justification of the use of this

type equipment cannot be made without thorough investigation of these conditions. Control diagrams should be developed with the various items of equipment being coordinated with the other building systems. Flow diagrams should be thoroughly rechecked for errors, capacities, flow patterns, and other related features, and any alterations to the diagram should be made. Equipment should be checked to be sure it will fit into the allotted space with clearances and access provided for maintenance and replacement. Final plans should indicate locations of duct test holes, control instruments, access doors and any special instructions. Plans should show design capacities and design loads. It is frequently found that using personnel attempt to operate systems in a manner not intended by the designer simply because the user has not been informed of the intended use. Where systems are designed to operate under a special set of conditions (such as a material handling system designed for 75 percent of the hooded equipment being used with 25 percent shut off by blast gates) these conditions should be stated in the form of notes on the final drawings. Notes of this nature which are on the final drawings serve as a good reference to inform others as to the designer's concept of operation. Flow diagrams or control diagrams are a good place for such notes.

603 MAKEUP AIR

1. General. Wherever laboratory or industrial ventilation is used makeup air is required. This makeup air may be provided either through the building heating and air-conditioning system or through separate makeup air systems specifically designed for the purpose. In determining which method is to be used careful thought must be given to future requirements for the building and to the necessity for control of air flow patterns within the building.

2. Building System. If makeup air is supplied through the building heating and air-conditioning system the following points must be considered:

a. Makeup air should be filtered, heated, cooled, humidified or dehumidified as

required to maintain the building comfort conditions.

b. Air should be supplied to areas of the building requiring this air for comfort reasons and not for laboratory or industrial ventilation reasons.

c. Makeup air processed in this manner should not be supplied directly to auxiliary supply air hoods. Not only is the air needed for building comfort but its temperature and humidity conditions are not desirable for direct supply to a hood.

d. Since air is distributed according to comfort requirements air flow patterns established are not likely to be desirable.

e. This system does not lend itself to the flexibility normally required for alterations in the ventilating system.

f. This type system is lower in first cost since fewer pieces of equipment are required.

3. Separate System. Where separate makeup air systems are being considered the following points should be studied:

a. Makeup air should be filtered as required by the areas being served. The makeup air should be heated, or cooled to approximately room conditions. However, in mild climates this may not be required.

b. Makeup air can be supplied directly to the area requiring it for laboratory or industrial ventilation needs.

c. Air flow patterns can be controlled better since distribution is based upon ventilation requirements.

d. Air can be supplied directly to auxiliary air supply hoods.

e. This system is flexible and adaptable to future alterations of ventilating systems. Building

comfort conditions are not affected by changes in makeup air requirements.

f. More equipment is required and separate ductwork is used for distribution making first cost of this system higher.

604 INTAKES AND EXHAUSTS

1. General. Intakes and exhausts are often located where it is most convenient for the designer with little thought given to the results. Improper positioning of intake openings or exhaust outlets will introduce hazards into a building with no provisions made to cope with the results. In addition to bringing in fumes, vapors, smoke or odors originating from exhausts of the building, these same elements may come from adjacent facilities. Excessive dirt or dust, explosive or flammable vapors, excessive heat and other elements may be introduced by poor location of intakes.

2. Intakes. In locating makeup air intakes it is suggested that the surrounding facilities be examined first. Exhausts from other facilities may influence the intake location if these facilities are close-by or if they emit a heavy concentration of contaminant. Heavily traveled roadways introduce exhaust emissions which are undesirable. Pressure regulating stations on gas distribution systems sometimes allow escaping of gas from pressure regulating or relief valves. Exhausts from engine driven stationary equipment or from trucks at loading and unloading docks are often obnoxious. Intakes located close to the ground may draw in an excessive load of dirt or dust unless the surrounding area is treated. Intakes over large paved areas or roofs may take in excessive heat. Intakes in area ways may be subject to flooding or excessive dirt. The effect of prevailing winds may have some bearing upon the locations selected.

3. Exhausts. Coordination with selected intake locations is a prime consideration in the selection of exhaust locations. Exhausts must be located or constructed in a manner to prevent the gases being recirculated into the building. Adjacent buildings must also be considered. Exhausts located on the roof should discharge straight up if possible;

and should extend as high as practical. Fumes, vapors and gases should not be diverted downward onto roofs where they could damage roofing. Some fumes and vapors from exhaust stacks are hazardous. These stacks should extend well above the roof to prevent injury to personnel or materials of construction. A guide to stack height is given in the publication "Industrial Ventilation," Figure 6-23. Figure 8-3 of the same publication shows three methods of constructing stacks with vertical discharge. ASHRAE Guide and Data Books discuss stack heights and relative locations of air intakes and exhaust. Exhaust outlets are sometimes located in building walls. Care should be taken not to locate these outlets under windows or close to doors where exhaust gases could re-enter the building.

605 CAPTURE AND TRANSPORT VELOCITIES

ASHRAE Guide and Data Books furnish capture and transport velocities for a large variety of material and systems. Particular attention to capture velocities and to design of hoods and entrances is required for successful operation.

606 MATERIALS OF CONSTRUCTION

Ductwork is frequently constructed of galvanized sheet steel with flanged, riveted or soldered seams; or of black sheet steel with welded seams. Ductwork handling radioactive material is often constructed of 316 stainless steel with interior joints smooth to facilitate cleaning and decontamination. Similar materials are used for construction of hoods for industrial uses. Where corrosive fumes or vapors are to be handled other materials may be used. The materials of construction should be selected to be consistent with the substance to be handled. ASHRAE Guide and Data Books list the relative resistance to corrosion of many materials. Table 8-1 of the publication "Industrial Ventilation" gives properties of many plastics.

607 CONTROLS AND INSTRUMENTATION

1. Controls. Since laboratory and industrial ventilation systems run nearly continuously there is

limited need for controls. Controls required are for starting and stopping the systems; temperature and humidity controls for makeup air systems; and those controls required by electrical codes for safe operation of electrical equipment. Switches for starting and stopping of the systems should be located in a place where workers in the building do **not** have ready access. Systems should be started and stopped by authorized personnel only. Exhaust systems and makeup air systems within a complete system should be electrically interlocked so that one switch starts both systems. Temperature and humidity controls should be located in a manner to preclude tampering by unauthorized personnel. Locking type covers can be used to prevent tampering but this is not a fool-proof method. Sailswitches in the air stream used as a means of interlocking systems are prone to stick, clog or corrode, particularly in exhaust systems. Controls should never be located in ducts or hoods handling corrosive materials or dusts or other materials which are likely to foul the control.

2. Instrumentation. The extent of installation of instrumentation on ventilation systems varies widely. The more hazardous the material being handled the more instrumentation is justified. However, some instrumentation is necessary on all systems.

a. Filters. All filters should be provided with a means of determining the filter condition. This is normally accomplished by the installation of a manometer, however, differential pressure switches and flow meters can be used. Manometers are available in a number of designs; U-Tube, inclined-vertical, and inclined. Differential pressure switches of the bellows or diaphragm type are available. Aneroid pressures gages which utilize magnetic linkages are frequently used for differential pressure indication. Flow meters which use velocity pressure as a means of indication are also available. Regardless of the type of instrument used to indicate filter condition the instrument scale should be marked in the field with normal reading when the filters are clean and the reading which indicated filters require servicing.

b. Air Flow. In systems handling toxic, noxious, radioactive, explosive, corrosive, or

flammable fumes, vapors or gases, it is recommended that instrumentation be provided to indicate that the exhaust air system is operating. Lights connected to electrical starting or running circuits are not reliable. These lights may indicate motor operation electrically but cannot indicate air flow stoppage due to mechanical reasons. Light bulbs also burn out at frequent intervals. Switches are not recommended in exhaust systems. Dust and dirt will foul these instruments. Corrosive fumes or vapors will also damage them. Gages similar to "Magnehelic" manufactured by F.W. Dwyer Co. have been used with some success but are also subject to corrosive action. Manometers can be used in connection with a calibrated orifice or a run of ductwork however, these cannot be used in material handling systems. Instrument scales should be marked to show the reading which indicates normal air flow. Where such instrumentation is used it is usually desirable to have instruments sound an alarm in case of malfunction.

c. Detectors. Detectors are available to indicate the presence of a number of gases or vapors. Where highly toxic or hazardous material is being handled or there is danger of such material being present the use of detectors is justified. Alarms are usually installed in connection with detectors of this nature.

608 POLLUTION CONTROLS

Every precaution must be taken to eliminate exhausting polluted air to the atmosphere, or discharging contaminated water into ditches or streams. Local and state codes, regulations or ordinances may govern the extent to which pollution control must be exercised. Compliance with these codes, regulations and ordinances should be in accordance with NASA Handbook NHB 7320.1, "Facilities Engineering Handbook." Air cleaning devices should have as high an efficiency as possible consistent with the contaminant involved, its concentration, and the governing codes or laws. Water being discharged from air cleaning devices shall be filtered, routed to settling basins or otherwise treated before being discharged to ditches or streams.

609 DUCT AND EQUIPMENT IDENTIFICATION

Ducts and equipment handling hazardous material must be marked with identifying code as required by proposed NASA Handbook "Identification of Utility Systems." Where radioactive material is being handled ducts and equipment must be marked in accordance with AEC regulations. Special attention should be given to marking access doors or panels which maintenance personnel will use; such as, removable panels for access to filters. Exhaust ducts or stacks should be clearly marked and arranged to prevent contaminated air from being discharged onto nearby personnel.

610 FLOW DIAGRAMS

Flow diagrams which schematically indicate air flow within the building should be prepared as the design develops. These diagrams are usually block diagrams with one block representing each room. The arrangement, shape, and size of the blocks is determined by the designer and usually are arranged to indicate the various floor levels of a multi-story building. Solid lines with arrows are generally used to indicate air flow in ducts; dashed lines with arrows generally represent air flow within rooms or spaces, such as from a room to a corridor. Air quantities may be indicated by figures within a box in the line concerned. Fan symbols are used which pictorially symbolize the type fan used (centrifugal; roof exhauster; wall exhauster; propeller type; or other). Each block contains the room or space identification and may also contain design temperature and humidity conditions if desired. Heating coils or cooling coils and motor operated dampers may be indicated and labelled. The flow diagram should indicate the following information: 1) Air, cubic feet per minute, (c.f.m.) supplied to each space; 2) Air (c.f.m.) exhausted from each space; 3) Air (c.f.m.) returned through ducts from each space; 4) Air (c.f.m.) flowing between spaces either in ductwork or freely within the spaces; 5) The joining or separation of air streams or ductwork; 6) All air moving devices and their capacity in c.f.m.; 7) Hazardous conditions or precautions should be noted; 8) Exhaust discharge locations should be indicated (roof, wall, or other).

611 SYSTEM TESTING AND BALANCING

Efforts expended for system testing and balancing should be consistent with the type and complexity of the facility. Laboratory facilities are usually complex and should be thoroughly tested and balanced. Plans and specifications should be prepared to provide all necessary access, test holes, instrumentation, procedures and trained personnel as required to obtain a valid test and proper balance. Adequate inspection to insure the validity of these efforts should be provided. Consideration should be given to the use of professional testing and balancing organizations which are members of Associated Air Balance Council (AABC).

612 MISCELLANEOUS ITEMS

The miscellaneous items below are those easily overlooked during the design phase; and although all possible items are not included, they will serve as a reminder to the design engineer.

- a. Where roof mounted equipment is used, proper access should be provided for ease of maintenance. Protection, such as duckboards, should be provided as required for the roof to prevent damage due to traffic of maintenance personnel.
- b. Close attention should be given to access space for filter removal, filter bagging and cleaning of filter racks.
- c. Access panels and doors must be provided for duct mounted equipment. Panels or doors should be provided as needed in ducts, ceilings or walls.
- d. Fire dampers and access panels must be provided as required by N.F.P.A. and local fire codes.
- e. Control systems should be kept as simple as practical.
- f. Variable pitch sheaves should be provided for all belt driven fans.
- g. Guards should be provided for all belt drives. Holes should be provided in guards at

the driven equipment end to allow the use of a tachometer without removing the guard.

- h. Systems should be thoroughly tested upon completion. Tests should be conducted with all systems in operation.

- i. Test holes in ducts to allow sufficient readings to be taken with pitot tube or other instruments should be provided. Covers should be provided for all holes.

- j. Instrumentation should be provided in locations to allow easy reading of instrument scales.

- k. Where future expansion is a known factor, oversizing of equipment to facilitate expansion should be considered. Space should be provided for future equipment. Future equipment outlines should be shown on drawings to prevent the space being inadvertently used for other purposes.

- l. Flexible connections in piping and ductwork and vibration isolation units for equipment to prevent noise and vibration being conducted through the building should be provided. Sufficient anchors for piping where flexible joints are used should be provided.

- m. Drainage for ducts where condensation of vapors is possible should be provided.

- n. Ductwork for handling radioactive material in the airstream should be constructed of 316 stainless steel or similar material to allow easy cleaning.

- o. Ductwork and hoods constructed of polypropylene do not give adequate fire protection. Use of hoods or ducts made of this material must be carefully determined.

- p. All outside air taken into a system for distribution should be filtered.

- q. Where ozone is generated, ventilation to the outside is preferred.

r. Where pressurized gas cylinders are used in conjunction with laboratory hoods, the cylinders should be hooded.

s. Switches and lighting fixtures installed inside of laboratory hoods should be explosion proof.

t. Plans should contain notes explaining special operation conditions, sequences, control settings, etc.

u. Written control sequence should accompany all control plans.

v. Balanced flow diagrams should be provided for all systems.

CHAPTER 7: ALTERATIONS

TABLE OF CONTENTS

Paragraph	Page
701 GENERAL	7-1
702 BALANCE OF SYSTEMS	7-1
703 CAPACITY	7-1
704 HAZARDS	7-1
705 SELECTION OF EQUIPMENT	7-2
1. Existing Equipment	7-2
2. New Equipment	7-2
706 EQUIPMENT DATA AND FLOW DIAGRAMS	7-2
1. Equipment Data	7-2
2. Flow Diagrams	7-3





CHAPTER 7: ALTERATIONS

701 GENERAL

The task of altering an existing ventilation system is more difficult than the original design and construction in many ways. The engineer charged with designing an alteration must first of all have a good knowledge of the desired results and the means of obtaining them. Secondly he must be thoroughly familiar with the existing systems; their capacity, the original concept of design or design intent and the limitations of the existing equipment and systems. Installation of new equipment and ductwork is complicated by existing construction and limited access for working. Further complications may arise due to occupation of the building while alterations are in progress.

702 BALANCE OF SYSTEMS

A properly altered system will maintain the balance of makeup air and exhaust air within the building. Air flow patterns will remain unchanged except in that area where alterations are desired. To accomplish this a study of the existing air flow patterns must be made. A properly updated flow diagram is invaluable for this purpose. Changes in exhaust air from a given area must be accompanied by an equal change in makeup air to the same area. Creation of new areas of positive or negative pressures will change air flow patterns in adjacent areas. Such alterations must be carefully studied. An alteration which creates a new negative or positive area, such as the addition of a new hood without an equal increase in makeup air, will alter the capacity of all other systems serving that area. Such a change can conceivably cause a back draft in another system. The change creates additional static pressure against which all exhaust fans serving the area must work. Air flow patterns are thus changed. If existing duct systems are altered the entire system must be rebalanced. Changes in ductwork change the static pressure the fan is operating against thus changing the fan capacity. Correction by varying the fan revolutions per minute and horsepower may be possible. Files of existing equipment complete enough to show fan capacity curves or tables are highly desirable. Balancing of all new and old equipment which serve the area altered must be accomplished.

703 CAPACITY

System capacity and system balancing of all systems goes hand in hand. It must be remembered that installation of a new system or altering the capacity of an old system can have an effect on other systems. Frequently alterations require only small changes in fan capacity. The existing fan may be satisfactory in these cases, if the fan speed is properly adjusted. It is necessary to have available the "capacity—static pressure" curves or charts for the particular fan in question to make this determination. System static pressures should be carefully calculated with the new capacities. Entrance losses, losses through filters or air cleaners, and other losses, should be calculated. Motor size must be checked. Where an axial flow fan is involved the addition of static pressure will have a decided effect on fan capacity. Where a forward curved blade centrifugal fan is involved the "dip" in the fan "static pressure—capacity" curve must be considered. If the new static pressure falls in the area of this "dip" the fan may operate at either of **two** capacities. In such cases the fan "hunts", that is it will jump from one capacity to the other thus giving unsatisfactory results. A decrease in static pressure of the system will result in a higher fan capacity and in some cases higher horsepower. It can readily be seen that files of existing equipment characteristics are extremely valuable in evaluation of proposed alterations. Filters and air cleaning devices must be checked. A change in filter face velocity not only changes the pressure drop through the filter but changes the filter efficiency. An increase in air volume through a centrifugal type collector may reduce the efficiency of the collector. Similarly a decrease in air volume may reduce the centrifugal action causing a decrease in efficiency.

704 HAZARDS

When an alteration is required for a new or different process or project, a close examination of the new process and the existing materials of construction is required. Sealant and adhesive material as well as the metals or plastics used in the construction of the ventilation system must be analyzed. The requirement for corrosion resistant materials, spark—proof fan construction, explosion

proof motors, and other special requirements must not be overlooked. Where central exhaust systems are involved, it must be remembered that all portions of the system are subject to the exhaust products at each hood or inlet. The mixing of exhaust gases from the new process must be compatible with other processes on the same system. Residual contamination from previous processes may be present in sealants, filters or on metal surfaces. Changes in air flow patterns within the room or between rooms must be carefully planned. Environmental health or safety personnel should be consulted to determine if hazards exist. It is good practice to consult these specialists during the planning stage of any alteration. Overloading of building electrical circuits may also be classified as a hazard. Multiple alterations of a minor nature over a period of time have a way of being overlooked. Individual circuits are often checked but overall building loads are more difficult to determine and consume more times. Electrical service to the building as well as building circuits should be checked.

705 SELECTION OF EQUIPMENT

1. Existing Equipment. Proper types of equipment should be used whenever an alteration is made. The use of existing equipment for monetary savings is encouraged provided the equipment is proper for the use intended. The use of improper equipment is dangerous and is false economy. The following is a list of **improper** use of existing equipment. The list is by no means complete. Every effort must be made to eliminate similar improper equipment application.

- a. Use of axial flow fans when pressures involved are too high.
- b. Use of forward curved blade centrifugal fan in a material handling system where blades are likely to become clogged with material.
- c. The use of unit collectors where vapors are present.
- d. The use of standard fans where corrosive elements or flammable materials are to be handled.

e. The use of unprotected ductwork in corrosive atmospheres.

f. The use of "open" electric motors in a location subject to water spray, rain, splashing, or where heavy dust load is present.

g. The use of high speed or noisy fans in a quiet area.

h. The use of centrifugal fans of the wrong arrangement or rotation for the application.

2. New Equipment. New equipment is more likely to be properly selected for the application than is existing equipment. Space limitations often present a problem. Equipment arrangement and dimensions should be carefully checked to insure proper access for maintenance. Where clearances are insufficient the use of other fan arrangements, rotation or drives should be investigated. The use of roof mounted equipment may relieve a space problem. The use of **unproven** new types of equipment is often risky. Where the use of this type equipment is desirable the availability of parts and service and the economic stability of the manufacturer should be considered.

706 EQUIPMENT DATA AND FLOW DIAGRAMS

1. Equipment Data. When an attempt is made to evaluate an existing ventilation system, with the goal of altering it to perform a different function, the value of a good file on existing equipment is evident. Therefore, these files should be updated whenever alterations are made. Files on each building and system should be kept current reflecting the existing conditions. Files should contain the information shown below as a minimum.

a. **Fans** — Make; type; size; arrangement; rotation; type of drive; motor hp, electrical characteristics and type; tables or curves showing fan capacity vs. static pressure, horsepower and maintenance instructions.

b. **Filters** — Make; type; size; recommend face velocity range; pressure drop,

cleaning and maintenance instructions where applicable.

c. Electrostatic Precipitators — Make; type; model; size; capacity; face velocity range; performance specifications; dimensions; maintenance instructions; and electrical characteristics.

d. Separators — Make; type; size; model; capacity; range of air quantity or velocity; type fabric (if used); water requirements (if used); performance specifications; maintenance instructions, electrical characteristics (if applicable).

e. Hoods — Make; model; type; size; other catalog data of manufacturer if it is manufactured by a regular hood supply company.

f. Coils — Make; type; size; performance data (c.f.m.; g.p.m. of water or pounds

of steam; electrical data (if applicable); entering and leaving air conditions; B.T.U.; pressure drops, and face area).

g. Test Data. Fan r.p.m., c.f.m., electrical load, static pressure; filter pressure drop; and similar data on other system equipment.

2. Flow Diagrams. Flow diagrams should be brought up to date after each alteration. These diagrams should schematically show the information previously given in Chapter 6, "DESIGN". The value of an up-to-date flow diagram is evident when alteration planning is begun. It should therefore be brought up to date upon completion of the alteration.



CHAPTER 8: OPERATIONS AND MAINTENANCE

TABLE OF CONTENTS

Paragraph	Page
801 CONTROL AND COORDINATION	8-1
1. General	8-1
2. Surveillance	8-1
3. Operation	8-1
802 LABELING, REGISTERING AND FILES	8-1
1. General	8-1
2. Labels	8-1
3. Registering	8-2
4. Files	8-2
803 TESTING OF SYSTEMS	8-2
1. General	8-2
2. Initial Tests	8-2
3. Periodic Tests	8-3
4. Test Readings	8-4
804 HANDLING OF FILTERS	8-5
1. General	8-5
2. New Filters	8-5
3. Removal of Dirty Filters	8-5
4. Installation	8-6
5. Cleaning of Filters	8-6
805 DISPOSAL OF WASTE MATERIAL	8-6
806 IDENTIFICATION OF EQUIPMENT AND DUCTS	8-6
807 POSTING OF FLOW AND CONTROL DIAGRAMS	8-7
808 SCHEDULED MAINTENANCE	8-7





CHAPTER 8: OPERATIONS AND MAINTENANCE

801 CONTROL AND COORDINATION

1. General. Ventilation in laboratory or industrial facilities serves a variety of processes and personnel. There is a natural tendency of persons working in a facility to attempt to improve their own area of occupancy by making alterations to the existing ventilation system or by turning systems "on" or "off". The hazards of such unauthorized alterations and of improper operation of systems have been pointed out in previous chapters. Proper control and coordination of systems must be maintained. The burden of enforcing this control and coordination falls upon those responsible for operation and/or maintenance of the facilities and upon environmental health and safety personnel.

2. Surveillance. Continuing surveillance of ventilation systems is necessary to insure proper operation of systems and to discourage unauthorized tampering and alterations. In order to accomplish effective surveillance, operation and maintenance personnel must be trained to know and to recognize hazardous conditions, and to report these conditions when they are noticed. These personnel must, therefore, be thoroughly familiar with the facilities and should observe them frequently. Periodic inspection of ventilation systems should be made. In addition to the normal scheduled maintenance procedures such as lubrication, checking of drive belts, changing filters, etc.; maintenance personnel should make thorough inspections of the hoods and ducts. Inspectors should look for deficiencies such as obstructions, corrosion, leaks, damage, unauthorized air moving devices, unauthorized ducts, changed in settings of dampers or controls. Supervisors and using personnel should understand the importance of determining that ventilation hoods are operating in accordance with requirements for safety for their operation. Where it is determined that a hood or system is not operating within these requirements immediate action should be taken to insure safety. Shut down of a process may be required until proper ventilation is obtained. Improper operation or performance should be reported immediately. Environmental health and safety personnel should be immediately informed. Where questionable

performance occurs a determination of necessary corrective action should be made to insure proper action. This determination should be made jointly by maintenance personnel and environmental health and safety personnel.

3. Operation. Laboratory or industrial ventilation systems are designed to operate in conjunction with all other systems in the facility. Switches and controls for these systems should be located, or shielded in a manner to prevent tampering by unauthorized personnel. Systems should be started or stopped only by persons appointed to do so, who are cognizant of the coordination required with other systems and with the processes being conducted within the facility. In many facilities it is necessary to operate ventilation facilities 24 hours per day to prevent accumulation of objectionable or dangerous gases, fumes or vapors. In other facilities the ventilation systems may be turned off during periods of shut-down. Specific instructions in this regard should be posted. Controls and instruments should be marked to indicate their normal setting or reading.

802 LABELING, REGISTERING AND FILES

1. General. As an aid to control, coordination and maintenance of ventilating equipment, a system of checking equipment is essential. This checking system should include labeling of each piece of equipment in a system and registering that piece of equipment in a central filing system which contains all vital information concerning the equipment.

2. Labels. Labeling of equipment provides identification on the equipment to indicate that it is an authorized item of equipment. The label also should contain vital information to aid maintenance personnel in testing equipment. Labels with adhesive backing are preferable. Labels should be printed with blanks to be filled in to show the proper information.

a. Basic Information. The following information should be the minimum shown on each label.

(1) **Equipment No.** — This is a registration or identification number.

(2) **Description** — This should give the type of equipment such as; fan, laboratory hood, filter or other such description.

(3) **Location** — Building and room number or other location data.

(4) **Date of latest test.**

(5) **Remarks** — This space should be used to place any special qualifications or warnings. Perchloric acid hoods, hoods handling highly toxic or radioactive materials, and special cleaning instructions, are examples of situations where remarks are necessary.

b. Additional Information. Additional information may also be shown on the labels as an aid to operation and maintenance personnel.

(1) **System No.** — If systems are identified this will aid in equipment identification.

(2) **Motor HP and electrical data** (if applicable).

(3) **Design capacity** — This should indicate cubic feet per minute (c.f.m.), minimum face velocity, etc.

(4) **Pressure** — Proper static pressure readings at inlets and outlets or pressure differentials can be shown if applicable. Hood "suction" or "entrance loss" is helpful.

3. Registering. Each item of equipment should be registered. The registration should be entered in a file or book maintained in a central location by the persons responsible for surveillance and maintenance of the equipment. Registration data should duplicate that shown on the label as a minimum. Additional information may also be entered as desired. Registration may be maintained in conjunction with files on each piece of equipment.

4. Files. Complete and up to date files on each item of equipment and on each ventilating system should be maintained to aid in planning and design of alterations, in maintenance of equipment, and in testing of systems and equipment. Information which should be kept on file include:

a. Data shown on label and registration.

b. Plans of the ventilation system.

c. Flow diagrams for the system.

d. System control diagrams.

e. Engineering data on each item of equipment.

f. Capacity tables or charts.

g. Test records and readings. Original test data and the latest periodic test date and readings.

803 TESTING OF SYSTEMS

1. General. Ventilation systems should be given a thorough testing when they are first installed and placed into service. Thereafter, periodic tests should be conducted to insure proper operation. Simple ventilation systems which are not handling highly toxic, radioactive, highly flammable or explosive materials do not require extensive and complicated testing. The more complex or hazardous systems require more extensive and exacting tests. Both initial and periodic tests should be made in cooperation with the environmental health and safety personnel. The extent of the testing involved should be determined by these specialists.

2. Initial Tests. Upon completion of a new or altered ventilation system complete and comprehensive tests should be conducted. These tests should verify: 1) That exhaust volumes, makeup air volumes, distribution of air, air flow patterns and air balance are in agreement with the

design data; 2) That contamination control is effective; 3) That all items of ventilation equipment are performing properly. The first step in this procedure is to sketch the system showing size, length and relative location of all ducts, fittings and equipment in the system. This sketch will aid in determination of test point locations. Initial air measurements should include:

- a. Air velocity in each branch and in the main duct and the resulting air quantities.
- b. Static pressure measurements in each branch and in the main duct.
- c. Static pressure measurements (throat suction) at each exhaust opening or connection to a hood.
- d. Static and total pressure measurements at both fan inlet and outlet.
- e. Static and total pressure measurements at inlet and outlet of each air cleaning device.
- f. Face velocity measurements at the face of each laboratory type hood.

Measurement data will indicate any variation from design data and the need for balancing to obtain proper distribution. Transport and capture velocities can be verified for the material to be handled. Where imbalance is found corrections should be made and new test measurements made. All measurements and location of measuring points should be recorded and placed in the system file. Hood design checks should verify that the source of contamination is effectively hooded. Air analysis requirements will vary with the contaminant, using air sampling at various points where toxic, flammable, explosive or radioactive materials are to be handled. Where non-hazardous materials are being handled air analysis is not necessary, and visual observation for escapement will suffice. Smoke bombs or other smoke or vapor sources may be used to determine air flow patterns. Where exhaust ducts are under positive pressure they should be given a thorough leak check using smoke

or other means of determining leak locations. Fans, motors, drives, pumps, and other mechanical items of equipment should be checked for proper operation. Rotation, RPM, electrical power consumption (amperes), and similar features should be measured and checked against the manufacturers data to determine proper operation and capacity. These values should be recorded in the system file.

3. Periodic Tests. For most existing systems, elaborate air sampling studies and tests are not necessary at frequent intervals. Unless the process has changed, the hoods or enclosures altered, or major items of equipment changed; contamination should remain controlled as long as the equipment is properly operating. Proper operation of items of equipment such as fans, drives, pumps, filters, and collectors should be checked. Periodic tests should be made on a scheduled basis. The frequency of the tests will be dependent upon the complexity of the systems and the hazards involved. Determination of the frequency is a matter of judgement based upon past experience with the type hazards involved. Where contaminant has a nuisance value only, periodic checks semi-annually or annually may be sufficient. Where hazardous material is being handled test may be required quarterly. Except in extremely hazardous cases periodic checks on air flow can be made by checking a few pressure readings and velocity readings. If initial or previous test data has been recorded while the system is operating properly, hood suction readings can be made and compared with previous readings. This will give a reliable comparison of performance. A change in hood suction can only indicate a change in velocity in the branch and consequently a change in air volume removed from the hood. This relation is true unless system alterations have been made, the hood has been altered, or there are obstructions or accumulations in the hood or branch ahead of the point where the reading is made. Pressure readings vary as the square of the velocity or volume in question. A small change is magnified by comparison of pressure measurement readings. When marked changes in readings occur, investigation to determine the cause should immediately be started. When highly hazardous systems are involved, air flow pattern determination should be made in

addition to the above. Tests for leaks may also be appropriate. Periodic checks should always include a visual inspection of the system to determine points of possible failures. Belt drives should be carefully checked for wear and adjustment. Points requiring lubrication should be checked. Operation of instruments and controls should be verified as proper. Hoods, ducts, fans and air cleaning devices should be inspected for corrosion, fouling or damage. Labels and registration of equipment should always be verified.

4. Test Readings.

a. **Velocity Readings.** The most important measurement in testing a ventilation system is, in most cases, the measurement of air quantity. Most meters used for field measurements are velocity type meters. Therefore, it is necessary to obtain the cross-sectional area at the point of measurement as well as the average velocity at that point. The quantity of air can then be determined from the simple equation:

$$Q = VA$$

where Q = Quantity of air flowing, cubic feet per minute (c.f.m.)

A = Cross-sectional area of duct or hood at the point of measurement, square feet.

V = Average velocity, foot per minute (f.p.m.)

In taking these measurements certain precautions must be taken to eliminate inaccuracies which can easily creep into the results. Readings of low velocities at large cross-sectional areas is difficult. Most velocity meters are not accurate at very low velocities and drafts or cross currents of air may effect the readings. The configuration of many hoods and their location on machines makes accurate determination of face area and average velocity difficult in some applications. Machine operation may induce air flow or currents which do not appear when the machine is not running. Air quantity can, therefore, be more accurately

determined if the readings can be made in a duct serving the hood or inlet in question. (This does not mean that face velocity should not be read for laboratory hoods or other hoods with critical face velocity requirements). Average velocity determination should be made by taking a velocity traverse of the duct, averaging the readings taken. Velocity instruments measure the velocity only at a specific point in the air stream and, because the velocity varies from point to point, the accuracy of the reading will depend upon the number of elements into which the area is divided. Proper methods of making a traverse and taking readings are explained in the publication "Industrial Ventilation" and in the ASHRAE Guide and Data Books. Velocity readings taken at a ceiling diffuser or grille must be taken as directed by the manufacturer of the instrument used. Also these readings must be corrected by the "K" factor for that particular make and model of diffuser or grille. Actual face areas are difficult to determine unless data from the diffuser manufacturer is available. The use of cones to place over a diffuser or grille can be considerably more accurate. Homemade cones should not be used however, since slight back pressures, turbulence, or other interference can effect the volumes of air. There are manufactured cones and permanent air velocity measuring devices which can be used in critical locations. These devices and cones are engineered and tested to give fairly accurate results. Air straightening cores are used and points of air measurement for a traverse are accurately determined and consistent. Dust and corrosion however will damage permanent installations.

b. **Pressure Readings.** Static pressure and total pressure readings should be taken with a standard pitot tube and manometer or with a swing vane anemometer or thermal potentiometer with special tips. Fan static pressure should be calculated by subtracting the total pressure at the fan inlet from the static pressure at the fan outlet. Pressure measurements must not be made at the heel of an elbow or other point where the static pressure readings may be inaccurate due to turbulence. A minimum of four readings should be taken at uniform distances around the duct to determine an accurate average or indicate a discrepancy. The tip

of a pitot tube, if used, must point directly into the air stream as static pressure readings are affected considerably by angularity to the direction of flow. Openings in ducts must be drilled holes, free of burrs or projections on the inner surface. This is of particular importance if a swing vane anemometer or thermal potentiometer is used.

c. **Throat Suction Method.** The "Throat-Suction" or "Hood Suction" method of estimating air flow into an exhaust hood or duct is a quick, simple and practical method; particularly if the readings taken are for confirmation only and can be compared with previously taken accurate measurements. This method is based on the principle of the orifice — the inlet end of the duct simulating the orifice. It is a fairly accurate estimation of rate of air flow in branch exhaust ducts if the measurement can be made at a point one to three diameters of straight duct downstream from the throat of the exhaust inlet, and if an accurate analysis of the coefficient of entry can be made. This method of testing existing systems is outlined in the publication "Industrial Ventilation". Once determination of flow has been made with the proper air quantity and manometer readings taken and recorded, periodic checks may consist of taking manometer readings only and comparing them to the recorded values. If significant change in the readings is noted, investigation as to the cause should be made.

804 HANDLING OF FILTERS

1. General. Filters are installed in a ventilation system to remove contamination from the air. Unless these filters receive proper attention they cannot function as intended. Proper attention begins with the shipment of filters and includes storage, installation, removal, and cleaning or disposal.

2. New Filters. It must be assumed that new filters leave the manufacturers warehouse in good condition. (Except HEPA filters where quality assurance testing is required.) These filters may not arrive in good condition however. Cartons containing filters should be carefully inspected when they arrive and before they are accepted from the shipping agency. This does not mean that faulty

filters are never shipped from a manufacturer, but opening of cartons and individual inspection of each filter is not practical, nor does it lend itself to proper storage. Cartons should be examined for physical damage and for stains or water marks which may indicate they were exposed to damaging environment. Where such damage is found the shipping agency should be notified and agreement reached as to inspection and acceptance conditions. Filters must be stored in a dry area and protected from dirt and damage. Some manufacturers may place special storage and handling instructions on the carton. These instructions should always be followed. Improper handling may damage the filter frame or the filter media. Frame damage can normally be detected by visual inspection. Damage to filter media is not always detected so easily. High efficiency filters may require special test apparatus to find damage to the media. Quality assurance testing by AEC Quality Assurance Station as well as in-place testing should be considered. Maintenance personnel should be trained to handle filters carefully, particularly high efficiency types. Accidental damage may occur. Established maintenance procedures should be such that they will encourage personnel to report these accidents and not install the damaged filter as a cover up.

3. Removal of Dirty Filters. Each filter installation should be provided with means to determine when the filters should be serviced. These meters or devices should be observed on a scheduled basis often enough to allow servicing before the filters are clogged. Systems should be shut down for filter removal. Special care must be taken to prevent sloughing-off of contaminated material when removing filters. Filter racks should be cleaned, preferably by vacuuming. Any contamination on the leaving side of the filter rack or holding frame should be removed. If filters are the type which require calking to the rack, the old calking should be removed. Gaskets should be examined and repaired if required. If the system being serviced is one which handles toxic or radioactive material proper protective clothing and equipment must be used. This equipment should include suitable masks, clothing and breathing apparatus. Where radioactive material is involved the procedures, clothing and equipment must be in accordance with AEC requirements. The dirty filters should be placed into

a suitable container immediately to prevent contamination of the equipment area. Plastic bags may be used for many toxic materials. These containers should be tightly sealed and marked for proper disposal. Detailed procedures for replacement of filters handling highly toxic or radioactive material should be prepared by the maintenance personnel and the environmental health and safety personnel together.

4. Installation. After the dirty filters have been removed and the filter rack or holding frame cleaned the clean filters should be carefully inspected and installed. Special care should be taken to prevent damage to the filter media. Filters should fit tightly into racks or frames sealing air tight. Replaceable media type filters must be carefully handled and installed with the media tightly sealed to the frame. Some type filters require calking to the frame or rack to prevent leakage. Filters installed should always be the same type and efficiency as the type originally installed in the system unless a careful analysis has been made of the system and the filters. Changes such as filter types, models or efficiencies can cause problems due to changes in pressure drops, cleanliness, fit of filters to existing frames, or other conditions. Where filters are being replaced in clean spaces the filters should be tested to assure complete sealing between the filter frames and the filter holding rack. Tests of the media may also be required. Leaks should be calked or sealed as recommended by the manufacturer. When new filters have been installed and tested the manometer or other device to indicate filter pressure drop or condition should be checked for proper operation.

5. Cleaning of Filters. Washable type filters should be washed, inspected and coated with viscous material as recommended by the manufacturer. Storage racks should be provided for spare filters. These storage racks should be arranged to protect the filters from physical damage and to keep them in a clean condition while stored.

805 DISPOSAL OF WASTE MATERIAL

The problem of disposing of waste material from ventilation systems differs little from disposal of waste material from laboratory projects and

industrial processes. Many of the waste products present no hazards and may be disposed of in the normal manner at the site. Precautions should be taken however to prevent hazardous materials from entering normal waste facilities where they may cause injury to maintenance personnel or pollute the atmosphere or water. Hazardous solid materials should be collected in separate containers from normal waste. These containers should be closed and marked to indicate the hazard. Means of disposal will vary with the hazard and the available facilities. Liquid waste such as water from an air cleaning device or collector should enter a settling or neutralizing basin or be treated or filtered as appropriate for the hazard. After treatment or clarification to an extent that will relieve hazards, the liquid may be disposed of in the normal manner. Caution should be exercised however, in emptying liquid waste into a sanitary waste system. Many chemicals will damage the chemical or biological action used by sanitary treatment facilities, thus causing even greater disposal problems. Local codes and laws governing pollution should be observed in all cases.

806 IDENTIFICATION OF EQUIPMENT AND DUCTS

Identification of piping as an aid to operation and maintenance personnel has long been a standard practice. This identification not only designated various materials being conducted in the piping but also indicated the degree of hazard. Similar identification for laboratory and industrial ventilation ducts and equipment should be used as a protective measure for operation and maintenance personnel. Any ductwork, fan, air cleaning device, or exhaust outlet which conducts hazardous material should be marked to indicate the hazard. This identification is required by the proposed NASA Handbook "Identification of Utility Systems." Where radioactive material is being handled in the ductwork or by the equipment, marking must be accomplished in accordance with AEC regulations. Special attention should be given to marking access doors or panels for servicing of filters or air cleaning devices. All such access points into the system should be marked. Exhaust stacks should be identified to prevent personnel from unnecessarily exposing themselves to hazardous exhaust streams.

807 POSTING OF FLOW AND CONTROL DIAGRAMS

The advantages and uses of up-to-date flow and control diagrams for designing, altering, testing and balancing systems have been pointed out in previous paragraphs and chapters. These diagrams can also serve as a ready and convenient reference for the maintenance man on-the-job trying to correct a system malfunction. Flow and control diagrams should be readily available in the equipment room for each system. A written sequence of control should be available with the control diagram. The diagrams and control sequence may be in book or pamphlet form or may be posted on the equipment room wall. Many facilities are equipped with central control panels with space provided on the panel for these diagrams. Diagrams may be full size or may be photographically reduced to a convenient size. Lettering should be neat and clear and large enough to be clearly legible. Typing or mechanical lettering is preferable. The method of displaying the diagrams should allow notation and marks to be made on the diagram with pencil, and should also provide protection against dirt and damage. These diagrams provide a reference for the maintenance man to enable him to easily see what areas are served by a system; what equipment is included in each system; other systems which are interlocked with the system in question; control settings; air flow quantities; and the function of each control device. Notations can be made on these diagrams to aid in future servicing.

808 SCHEDULED MAINTENANCE

Proper use of scheduled or periodic maintenance can be a valuable aid to control of ventilation systems as well as being valuable preventive maintenance. Good scheduled maintenance involves more than servicing of filters, lubrication and belt adjustment. Maintenance personnel should be trained to observe and encouraged to visit areas other than mechanical equipment rooms and roofs where equipment is installed. Scheduled maintenance should include general observation and checking of the entire system. Listed below are some of the items that should be checked or observed that are often overlooked.

- a. Check for unusual vibrations.
- b. Check for corrosion and rust.
- c. Check for leaks in ductwork.
- d. Check for unusual wear.
- e. Check for loose screws and bolts.
- f. General observation for unauthorized equipment and changes.
- g. Check control settings.
- h. Evaluate the frequency of preventive maintenance versus actual conditions.

CHAPTER 9: A METHOD OF SYSTEM BALANCING

TABLE OF CONTENTS

Paragraph	Page
901 GENERAL	9-1
902 BASIC PRINCIPLES	9-1
903 PROPORTIONAL BALANCING PROCEDURE	9-2
1. Preparatory Steps	9-2
2. Preliminary Field Steps	9-2
3. Balancing	9-2



CHAPTER 9: A METHOD OF SYSTEM BALANCING

901 GENERAL

Methods of balancing duct systems are available in many publications. Most of these published methods deal with supply air systems rather than exhaust systems. The principles involved are no different. Pressures on the suction side of the exhaust fan are negative pressures whereas those on the discharge side, as in supply systems, are positive pressures. This method is written for an exhaust system but may be applied to a supply system if appropriate changes are made. Sheet Metal and Air Conditioning Contractors National Association's (SMACNA) "Manual for Balancing and Adjustment of Air Distribution Systems" and Associated Air Balance Council (AABC) "National Standards for Field Measurements and Instrumentation" are excellent references for balancing systems.

902 BASIC PRINCIPLES

The engineer designs a system to exhaust a required volume of air from each hood. The duct system components are sized to handle air without excessive negative pressure requirements for the fan. Under ideal conditions, the engineer can design a system which is self-balancing. That is, the pressure loss from the intake to the fan will be calculated to leave just enough pressure to overcome the entrance pressure loss through the hood. Since the duct system is field fabricated it is not possible to predict exactly the pressure requirements and, consequently, the air flow through each part of the system. For that reason, dampers are provided for final air flow adjustments. Fans usually operate at a constant speed and have characteristics such that for a given air flow rate the fan will operate at a given static pressure. If the pressure requirement changes, the quantity of air exhausted will also change. Each damper adjustment affects the pressure at the fan and the air flow through the system. The air flow into an individual hood cannot be adjusted without affecting the rest of the system. Therefore, the system must be balanced in accordance with some systematic procedure.

Figure 9-1 shows a fan and duct system and the pressure characteristics of that system. The duct system has four intakes with a damper in the

branch line. There is also a damper in the main duct between the fan and the first branch duct. Each part of the system has the characteristic that the pressure required to overcome the resistance of that section of the system varies as the square of the volume of air flowing through it. For example, Curve A shows the pressure characteristic of the last section of the duct from station 0 to station 1. As the flow increases from a value of eight units to a value of sixteen units, that is, as the flow doubles, the pressure requirement becomes four times as great and increases from one unit of pressure up to four units of pressure. As more sections are added to the duct system the same characteristic prevails. Curve C represents the system including the last three inlets and as the flow increases from eight to sixteen units the pressure requirement increases from three up to twelve units. Curve D shows the pressure requirement of the system from the inlet designated number 0 on to the inlet designated number 4 and this again has the square relation between the pressure requirement and the air flow. The entire system from station 0 to the fan is represented by Curve E and this includes the open damper in the duct system 4-5. If the damper in duct system 4-5 is partially closed a new system curve, Curve F, will be defined and the intersection of this curve with the fan curve will indicate the volume of air that will flow through the system. Notice that the relation between successive parts of the system upstream from the damper was not changed by varying the damper position. That is, the pressure requirement of the system section 0-2 is twice the pressure requirement of the system section 0-1 regardless of the position of the damper in duct system 4-5, and this relation is also independent of the total volume of air flowing. This illustrates a key point in proportionate balancing: Once the successive sections of a system are balanced or adjusted one to another, the relation of the two parts of the system will not be altered if those sections of the system are not further adjusted. For this reason in the proportional balancing procedure the inlet farthest from the fan is adjusted first, and it is adjusted to establish a ratio between a measured air flow at that point and the design air flow for that point. The next inlet nearest the fan is then adjusted until a ratio between an actual and design air flow is established

that is approximately the same as that established at the first inlet. The same relation between successive sections of the system also applies to entire branches of the system. That is, once two successive branches are adjusted the relation between the pressure requirements of the two branches that is established will not be altered by adjustments to the system downstream from those branches. A critical consideration in balancing is that inlets in the same branch be adjusted to the same ratio of actual to design air flow rate. Any ratio can be chosen as long as the same one is used for each inlet; however, a ratio near 1.0 is usually chosen since with a properly designed system this will result in the least adjustment of fan speed.

903 PROPORTIONAL BALANCING PROCEDURE

1. Preparatory Steps.

- a. Make sure that the system is finished and complete.
- b. Obtain the approved drawings showing each fan system and note the total flow for each system.
- c. Locate on the drawing each Main Duct* damper and each Branch Duct** damper.
- d. Prepare calculation and report sheets, record room location, inlet number, and design flow rate. See Figure 9-2.

* A Main Duct is defined as "A Duct that serves two or more branch ducts".

** A Branch Duct is defined as "A Duct that serves two or more inlets".

2. Preliminary Field Steps.

- a. Set all dampers throughout the system in open position.
- b. Start all fans. Check direction of rotation.
- c. Adjust fans if necessary to obtain the design air flow.

3. Balancing. Note the balancing work sheet, Figure No. 9-2. Space is provided for the numbering of the inlets. The work sheet should have the inlets numbered according to sequence and branch as shown in Figure 9-3. The farthest branch and the farthest inlet on the branch away from the fan will be inlet number one - on branch number one. The inlets are numbered consecutively working back **toward** the fan. It is very important that the inlets be numbered, tested, and adjusted in the described sequence. If this sequence is not followed, the procedure **will not** be valid.

- a. Spot check inlets along the branch to determine if enough air is being exhausted to give measurable readings.

- b. Measure velocities at inlet number one on farthest branch.

- c. Determine the average velocity and record the value in the Measured Velocity column marked Vel (M) under Adjustment I (Roman Numeral One). This indicates the first reading for that inlet.

- d. Determine the ratio of measured to design velocity and record R under Adjustment I and 1 B.

$$R = \frac{\text{Measured Velocity} = V(M)}{\text{Design Velocity} = V(D)}$$

- e. Proceed to the second inlet. Determine the average velocity $V(M)$ and Ratio (R) and record these values under Adjustment I and 2 A.

- f. Compare R values for 1 B and 2 A under Adjustment I. If the R values are not equal, adjust inlet number two so that R_2 will approach R_1 . **Do not** adjust outlet number one.

- g. After adjustment, Record $V(M)$ and R values for outlet number two under II and 2 A.

- h. Go back to inlet number one and measure $V(M)$. Record the $V(M)$ and R values under Adjustment II, 1 B. If R values shown under Adjustment II, 1 B and 2 A vary more than 0.1, they are not considered proportionally balanced one

to another; and further adjustment to inlet number two is needed. After each adjustment of inlet number two, record the new $V(M)$ and R values under 1 B and 2 A in each successive adjustment column. Once the prescribed limits are obtained, proceed to Step i.

i. After inlets 1 and 2 are satisfactorily balanced one to another, the final adjustment values of R and $V(M)$ from row 2 A shall be rewritten under column Adjustment I, Row 2 B.

j. Proceed to inlet number three. Measure $V(M)$ and record the $V(M)$ and R values under I, 3 A.

k. Compare 3 A and 2 B readings under Adjustment I. If necessary adjust inlet No. 3 (DO NOT ADJUST NO. 2 OR NO. 1) to obtain the same R value as shown for No. 2.

l. Any adjustments of inlet No. 3 will change the flow through inlets 2 and 1, however, as long as neither 2 nor 1 are adjusted they will remain proportionally balanced to each other. The final R value determined for inlet Nos. 2 and 3 will also apply to No. 1 and they will be proportionally balanced to each other.

m. Adjust inlet No. 4 so that its R value matches that of No. 3. Proceed in like manner to each inlet in the branch until all inlets are balanced proportionally to each other.

n. It is essential that once an inlet is proportionally balanced with the preceding inlet, no further adjustments be made to that or preceding inlets.

o. Balance each branch in a similar manner.

p. Measure air flow at a selected inlet in each of the two branches farthest from the fan. Adjust branch dampers until the R values for the selected inlets are equal. The two branch ducts are now proportionally balanced.

q. Adjust each branch to balance it proportionally with the preceding branch in the same manner that the inlets were balanced.

r. Check total air flow at the fan and adjust fan speed to obtain the correct total flow through the system.

Figure 9.1

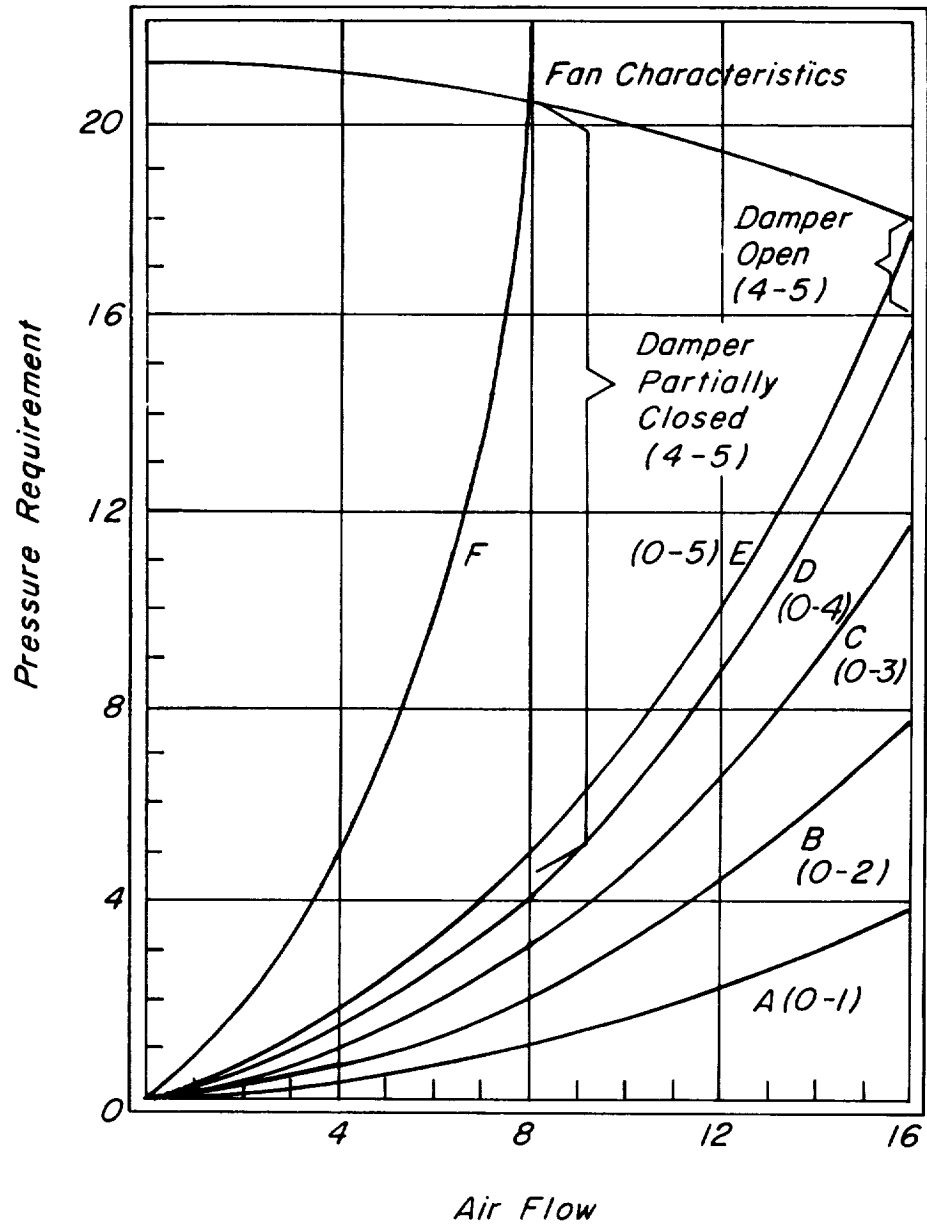
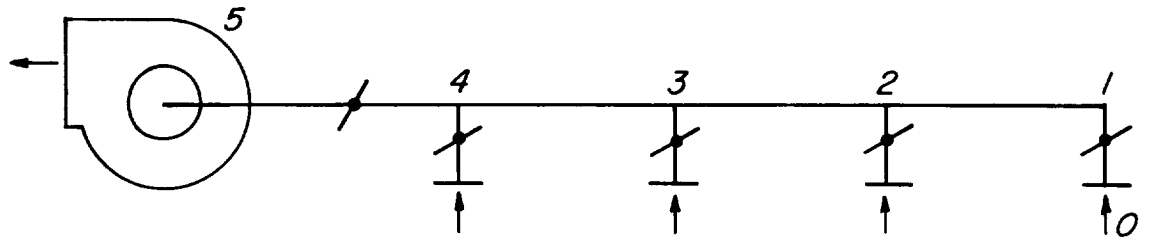

FAN AND SYSTEM CHARACTERISTICS

Figure 9.1

SYSTEM BALANCING WORKSHEET

Item No.	Room No.	Design		Adjustment									
				I		II		III		IV			
		Cfm.	Vel (D)*	Vel (M)*	R*	Vel (M)	R*	Vel (M)	R*	Vel (M)	R*		
1				1 B									
2				2 A 2 B									
3				3 A 3 B									
4				4 A 4 B									
5				5 A 5 B									
6				6 A 6 B									
7				7 A 7 B									
8				8 A 8 B									
9				9 A 9 B									
10				10 A 10 B									
11				11 A 11 B									
12				12 A 12 B									
13				13 A 13 B									
14				14 A 14 B									
15				15 A 15 B									

* D - Velocity at design condition R = M/D = Measured-to-design velocity ratio
 M - Measured velocity

Figure 9.2

Figure 9.3

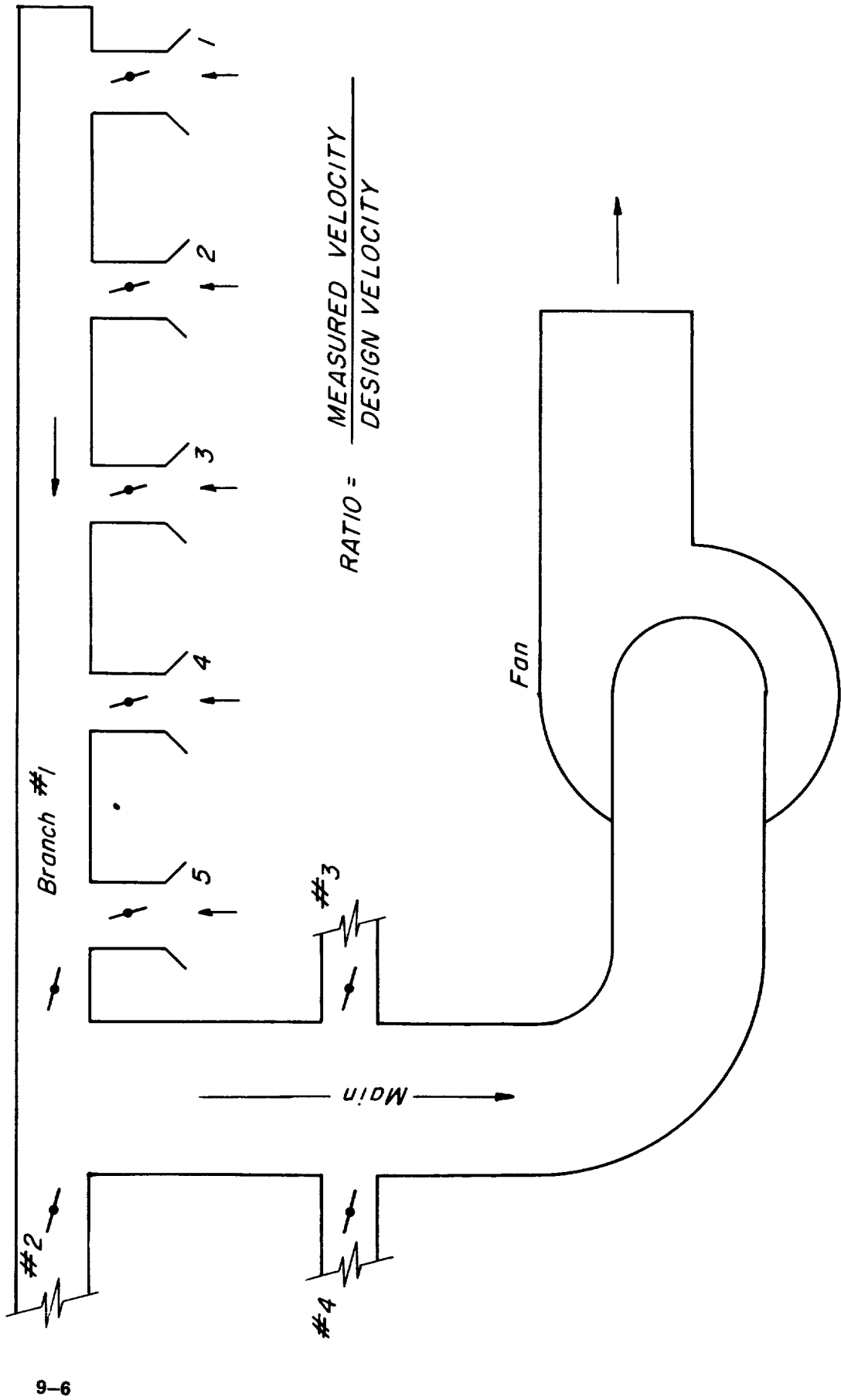

TYPICAL DUCT LAYOUT
Figure 9.3

CHAPTER 10: TESTING INSTRUMENTS

TABLE OF CONTENTS

Paragraph	Page
1001 PITOT TUBE	10-1
1002 MANOMETERS	10-1
1003 SWING VANE ANEMOMETER	10-1
1004 ROTATING VANE ANEMOMETER	10-1
1005 HEATED WIRE ANEMOMETER	10-1
1006 HEATED THERMOCUPLE ANEMOMETER	10-1
1007 SMOKE TUBES	10-1
1008 TRACER GAS-DILUTION	10-2
1009 ANEROID TYPE GAUGES	10-2
1010 BALANCING CONES	10-2
1011 PERMANENT VELOCITY MEASURING INSTRUMENTS	10-2
1012 INSTRUMENT SELECTION	10-2

CHAPTER 10: TESTING INSTRUMENTS

1001 PITOT TUBE

The pitot tube is the standard instrument for measurement of air velocity and pressure. The standard pitot tube needs no calibration if carefully made and velocity pressure readings obtained are accurate. The "Standard Test Code" published by Air Moving and Conditioning Association deals in detail with pitot tube specifications and application. Pitot tubes are best suited for reading air velocities above 800 f.p.m. Below this velocity other instruments are much more reliable. Pitot tubes are susceptible to clogging or plugging if used in an air stream with a heavy dust loading or high moisture content.

1002 MANOMETERS

The manometer is a simple and most common means of measuring partial vacuum and low pressure. It is a standard instrument and is often used to calibrate other instruments. The manometer consists of a U-shaped glass tube partly filled with liquid. The difference in the height of the two liquid columns denotes the difference in pressure on the two legs. Inclined manometers are commonly used to indicate pressure drop across filters as well as for measurement of static pressure, velocity pressure and total pressure in conjunction with a pitot tube.

1003 SWING VANE ANEMOMETER

The swing vane anemometer (such as Alnor Velometer) is extensively used in field measurements because of its portability, wide scale range and instantaneous reading features. The instrument has wide application and by using a number of fittings, can be used to check static pressures and velocities. The minimum velocity without special adaptation is 50 f.p.m. The instrument is fairly accurate and rugged, making it ideal for most field applications.

1004 ROTATING VANE ANEMOMETER

The standard rotating vane anemometer is accurate and can be used to measure air velocity in large openings of either supply or exhaust systems. The instrument constructed using a propeller or a

rotating vane connected through a gear train to a set of recording dials or gages. It reads linear feet of air passing in a measured time period (usually one minute). The instrument is made in various sizes; 3", 4" and 6" being the most popular. It has a useful range of 200 to 3,000 f.p.m. Specially built instruments are available for lower velocities. The rotating vane anemometer is not suited for general use of measuring velocities in ducts due to the instrument size. The standard instrument is not direct reading and requires a timed reading which introduces another source of error. The instrument is fragile and cannot be used in dusty or corrosive atmospheres.

1005 HEATED WIRE ANEMOMETER

The heated wire anemometer depends upon the variation of the electrical resistance of a wire with temperature. This type of instrument can also be used to measure the temperature of the air stream, and static pressures. Velocity measurement can be made from 10 f.p.m. to 8,000 f.p.m. and temperature measurements of 0 to 225°F. Instruments of this type are made for either permanent installation or portable use. The probe of portable instruments is subject to fouling by dust and corrosion. The instrument requires calibration at regular intervals.

1006 HEATED THERMOCOUPLE ANEMOMETER

This type instrument is based upon the principle that heat removal by an air stream passing a heated object is related to the velocity of the air stream. A number of this type of instrument are available commercially. Low velocities in the range of 10 – 25 f.p.m. can be estimated. The response is fairly rapid, being approximately one minute or less. Power is derived from batteries or an electrical outlet and transformer. Instruments of this type are most suited for measurements of low velocities, room air currents and hood face velocities.

1007 SMOKE TUBES

Low velocity measurements may be made by timing the travel of smoke clouds. This type of measurement is limited to velocities below 150

f.p.m. since higher velocities diffuse the smoke too rapidly. Smoke tubes or candles are commercially available for this use. This type measurement can be used for estimated flows only. Smoke candles are incendiary and thus can not be used in flammable atmospheres.

1008 TRACER GAS—DILUTION

The principle of dilution is sometimes used to determine rate of air flow. A tracer or test gas is continuously metered into a hood or duct opening along with the entering air stream. After thorough mixing air samples are collected at a point downstream and the concentration of test gas in the exit stream determined. The rate of air flow is calculated from the degree of dilution noted in the exit and feed gas concentrations.

1009 ANEROID TYPE GAUGES

This type of gauge is used as a field instrument for measuring static pressure, velocity or total pressure with a pitot tube, or for single tube static pressure measurement. A number of manufacturers offer this type gauge. Magnehelic, as manufactured by F. W. Dwyer Co., is probably the best known. These gauges are subject to mechanical failure and require periodic calibration checks and recalibration.

1010 BALANCING CONES

Measurement of air velocity from a ceiling diffuser or a register is a difficult and frustrating task. Proper "K" values for air flow must be obtained for the particular diffuser or register; fittings for the measuring instrument must be positioned exactly as prescribed by the instrument manufacturer, and free areas must be accurately obtained. Where measurement is being made at facilities which have been in use for some time it is extremely doubtful that "K" values and free areas data will be available. The use of balancing cones or hoods for measurements of this type is an old practice. This practice has been clouded with controversy as to its reliability and accuracy. Cones or hoods have been generally homemade with little or no testing. In many cases a single cone was used for almost any capacity. Cones caused back pressure

and turbulence which changed the volume of air supplied by the diffuser. The turbulence was carried through the cone to its outlet making accurate measurement impossible. Balancing cones are commercially available today. These cones come in several sizes for various ranges of capacity and incorporate a straightening core to reduce air turbulence. These cones are an improvement over the "homemade cone" of the past. Measurement of air velocity within a duct is considered much more reliable, but is not always possible or practical. Use of these cones is more reliable, however, than expedient of guessing at percent of free area of a register or the "K" factor for a diffuser. Accuracy obtained by using commercially available cones is sufficient for most ventilation applications.

1011 PERMANENT VELOCITY MEASURING INSTRUMENTS

Measurement of air velocity at frequent intervals may be required in some highly hazardous locations. Consideration should be given to the installation of permanent instruments for this measurement. A number of types of instruments are available. Installations of this type are not practical however, if these systems have a heavy dust loading or corrosive atmosphere. Either of these conditions will soon damage any permanent probe or tube in the duct.

1012 INSTRUMENT SELECTION

The selection of the proper instrument for the measurement involved is important. There is no one universal instrument for all cases. The publication "Industrial Ventilation" and the ASHRAE Guide and Data Books give various characteristics for air velocity measuring instruments. Instruments must be maintained and calibrated, otherwise they are of no value. Careful consideration must be given to obtaining the required instruments at each installation. The ASHRAE Guide and Data Books and Section 9 of the publication "Industrial Ventilation" give more detailed information on all instruments mentioned herein. Both references furnish comparison tables and limitations of the instruments.