

BINARY OPTICS AT HUGHES DANBURY OPTICAL SYSTEMS

February 1993

James Logue and Michael Power
Hughes Danbury Optical Systems, Inc.
100 Wooster Heights Road
Danbury, CT, 06810

ABSTRACT

An overview of binary optics development at Hughes Danbury Optical Systems is presented. Design software used for mask design is presented. A brief discussion of fabrication follows. Two examples of actual projects are used to highlight the discussion: 1) a large aspheric lens and 2) a set of grating and lenslet arrays.

1.0 INTRODUCTION

Binary Optics components are fabricated to provide support to various programs at Hughes Danbury Optical Systems (HDOS). We have the capability to design and fabricate lenses, lens arrays, gratings, grating arrays, null correctors, and custom elements for special applications.

This paper will review the design and fabrication capability at HDOS. First, the software supporting mask design and the conversion of optic prescriptions into e-beam (MEBES) format for mask fabrication will be reviewed. Second, the fabrication of the binary optic from the e-beam masks will be covered. Lastly, two examples will be presented, highlighting the process flow we use to design and fabricate binary optics. The first example is a large aspheric lens and the second example is a set of grating and lens arrays.

2.0 SOFTWARE FOR MASK DESIGN

Software has been developed at HDOS to convert optical designs into e-beam (MEBES) data files.¹ Computer Aided Design (CAD) software (MicroStation PC) is used to design the mask set for a binary optic. This involves defining the placement of the MEBES files describing the optic and placement of alignment and fiducial marks. CAD data can be converted into MEBES format and vice-versa. Figure 1 shows the basic components and data flows of the binary optics design software. All of this software has been integrated to run on a 486-PC bases workstation.

The design conversion software is a set of FORTRAN subroutines and drivers that can be linked to customized interface subroutines which define the interface with an optic design. Two custom subroutine are required - one to compute the phase at a given position and one to set the design parameters for the phase equations in the first module. For example, a program to compute MEBES data for zone plates has a subroutine called PHASE(X,Y) to compute the phase of the zone plate at (X,Y) and a subroutine called DEFINE to set the wavelength and focal length of the zone plate for the user. These two custom subroutines, PHASE(X,Y) and DEFINE, are linked into the binary optics software library to create a program, ZONEMEBES, which generates MEBES files for zone plates.

We have developed custom interfaces with HDOS lens design software to support the generation of MEBES data for zone plates, aspheric lenses, gratings, Zernike surfaces, and b-spline surfaces. On one occasion, a special interface was developed to generate MEBES masks for a polar-log transform lens.²

Mask layout and design is done using CAD software. HDOS is currently using Intergraph's MicroStation PC. This program has multi-level design capability and supports cell libraries. We have created a cell library containing all of our standard alignment and calibration patterns. As shown in the following examples, this package helps us to rapidly design a complex mask set.

¹. James Logue and Marilyn L. Chisholm, "General approaches to mask design for binary optics", Holographic Optics: Optically and Computer Generated, Ivan N. Cindrich, Sing H. Lee, Eds., Proc. SPIE 1052, 19-24 (1989).

². David A. Zweig, Michael P. Power, Thomas J. McHugh, and James E. Logue, "Geometric transformations using binary optics", OSA Annual Meeting, 1989 Technical Digest Series, Vol. 18 (Optical Society of America, Washington, D.C., 1989).

The design laid out in MicroStation PC can be extracted by level and converted into MEBES format using the same conversion software described above to support generation of optical MEBES data. In this case, the custom subroutines are designed to extract and convert CAD commands into MEBES format.

MicroStation PC is also used to examine MEBES data and to generate check plots and blueprints. Conversion software has been developed to translate MEBES data into MicroStation CAD format. This allows us to capture and inspect MEBES data, either for checking MEBES data generated from optic prescriptions or for inspecting and capturing data provided to us in MEBES format.

Our binary optics design software and the CAD software run on a 486-PC based workstation with the following components.

- 9-track tape drive (1600/3200 BPI)
- hi-resolution VGA color monitor
- 660 MB hard drive
- HP LaserJet III printer
- Hughes network interface

3.0 BINARY OPTICS FABRICATION

In the fabrication area we use a basic set of equipment that is customized to handle the various substrate materials, sizes, and shapes which are defined by the design requirements of the particular optic being generated. Figure 2 shows the basic process flow using this equipment.

Cleanroom Class 10000	Laminar Hoods Class 1000, Chemical Hoods
Headway Spinner	Photoresist application on substrate
Cleanroom Ovens	Prebake/Postbake
Modified MJB3 Karl Suss Mask Aligner	Photolithographic Alignment/Exposure
Veeco 3" Ion Miller	Etching of the masked steps
Alpha-step; Dektak	Profilometers
Optical microscopes; SEM	Inspection

Over the years we have worked with a wide variety of materials.

crystal quartz	fused silica	BK7 BaF3	ZKN7	Ge	ZnSe ZnS
GaAs	Silicon	CdTe	Mica	dielectrics	etc.

Each material requires developing a particular process recipe that includes choice of photoresist, determination of etch rate, aspect ratios (resist/substrate), exposure/development latitudes (resist/substrate; linewidth/depth/area), special interface layers, jigs and fixturing, etc. We have done the bulk of our etching of binary optics using an ion miller which utilizes a neutral Ar⁺ ion beam which generally eliminates the need to determine process chemistries as we change from one material to another. This is a multi-staged system capable of milling at multiple angles relative to normal. We also incorporate various in-situ monitoring schemes along with extensive use of profilometry to calibrate/control geometries of the etch process on each substrate.

4.0 EXAMPLE 1: LARGE ASPHERIC LENS

This section describes the design and fabrication of a large aspheric lens. The lens prescription is

$$f(r) = 3.38 r - 3.36e-3 r^3 + 1.40e-6 r^5, \text{ (r in mm)}$$

$$r_{\max} = 32.8 \text{ mm.}$$

Analysis of the phase equation above yields the minimum feature size and the estimated amount MEBES data required for each mask.

MASK #	MINIMUM FEATURE SIZE (MICRONS)	ESTIMATED DATA VOLUME (MB)
1	11.7	28
2	5.8	56
3	2.9	112
4	1.5	224

The data volumes are based on using a 0.2 micron address resolution for the MEBES data. This is sufficient to resolve the 1.5 micron lines on the fourth

mask. All four masks will be made using a 0.2 micron resolution to provide exact level-to-level alignment in the lens data.

The data volume required for this lens presented us with a problem. The maximum MEBES file size supported by our software is 64 MB.³ This forced us to partition the lens data for the third and fourth masks as shown in Figure 3. This works well, as long as all quadrant data is explicitly generated by the aspheric lens conversion program. On our first attempt, in an attempt to save time, we used the aspheric conversion program to generate one quadrant of data (FILE 1). We asked the mask vendor to use MEBES utility software to generate the missing quadrants for the third mask by taking advantage of the axial symmetry of the lens data about its center. Unfortunately, the resulting mask contained minuscule roundoff errors which had been introduced by the utility software chosen by the mask vendor. After fabricating the lens, a shadow image was noticed in the image of the test system using the binary aspheric lens. This was traced back to an apparent phase shift in the fourth quadrant of the lens. We believe that this was due to roundoff errors in the data for FILE 4 for the third mask.

For all four MEBES masks, calibration and alignment marks were placed using MicroStation PC. These marks were used for mask-to-mask alignment, mask-to-substrate alignment, and feature size calibration. HDOS conversion software was used to extract the mask information from the CAD files and convert it into MEBES files for mask fabrication. Additionally, the mask layouts were printed out for use as specifications to the mask vendor (see Figure 4).

In keeping with the theme of pointing out some of the pitfalls we have encounter in designing and fabricating a wide variety of binary optics, we encountered a problem with double exposure of the resist in the center zones of this optic after the first level etch had defined the fresnel zones and the second mask was being exposed. This was caused by a reflection of the focused rays from the back surface of the optic. This led to the requirement of using a blocking layer between the resist and the optic to prevent this back reflection. We had used this particular scheme in the past to provide an enhanced image of the previously exposed layer for alignment purposes of the next mask, especially for very narrow linewidths or when the etch depth is very shallow, such that it is hard to see the original image through the subsequent mask or resist layer.

³. Actually MEBES files can be as large as 128 MB, but we have limited ourselves to 64 MB for now.

5.0 EXAMPLE 2: GRATING AND LENSLET ARRAYS

This section describes the design and fabrication of two lenslet arrays and a set of four grating arrays. All six arrays are hexagonal arrays on 5 mm centers. Each lenslet array contains 23 lenses, selected from three different aspheric lenses, each 5 mm in diameter, with the following prescriptions.

$$\begin{aligned}\text{Ia: } f(r) &= 92.8 r - 2.87e-2 r^3 + 1.52e-5 r^5, \text{ (r in mm)} \\ \text{Ib: } f(r) &= 66.5 r - 2.57e-2 r^3 + 1.54e-5 r^5 \\ \text{II: } f(r) &= 20.7 r - 2.85e-3 r^3 - 2.37e-6 r^5\end{aligned}$$

The grating arrays consist of 12 or 17 gratings, all different, placed on the same hexagonal grid used for the lenslet array. Each grating array also contains four targets aligned to the type Ia and Ib lenses.

The main complication in this job was handling the many data files required. Including the lens data files, grating data files, and calibration/alignment data files, there were 67 data files to be placed on 6 MEBES masks (see Figures 5 and 6). MicroStation PC was used to design the mask layouts and insure mask-to-mask alignment for the lenslet arrays and lens-to-target/grating alignment between the lenslet and grating arrays. Additionally, the six grating and lenslet arrays were placed in pairs on three MEBES masks to optimize mask costs. Additional marks defining the cut lines for each array had to be placed with the calibration and alignment marks. The convenience of using integrated software on a single workstation made this job relatively easy, since blueprints and checkplots could be generated at all stages of the design to insure that the masks would be correct on the first attempt.

In the fabrication of this set of optics, we encountered another problem due to material properties that sometimes present unique challenges when the system requirements call for changes in either the substrate material or the geometry (size, shape, thickness, etc.) of the particular optic. Here the rate of etching of the resist relative to the etch depth in the substrate was relatively high due in part to poor heat transfer from the substrate and to a minor extent to the substrate material makeup, which required extensive rework of the resist process; as the linewidth to depth ratios also varied widely over the total area of the arrays. This type of problem is overcome by maintaining an extensive set of resist recipes and continually updating resists and resist property definitions as new products emerge on the market. Over the years we have done extensive work in all types of device processing outside the realm of binary optics and have developed methodologies that are easily traded off against each other to solve problems that are encountered in the fabrication of binary optics.

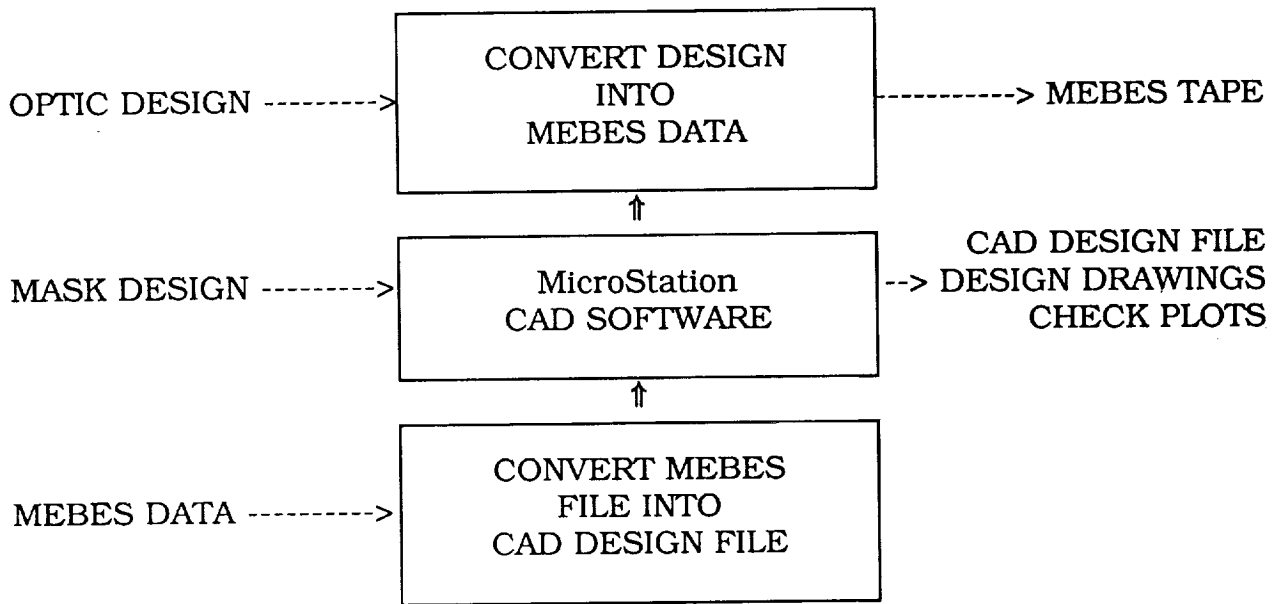

FIGURE 1. BINARY OPTICS MASK DESIGN SOFTWARE BLOCK DIAGRAM

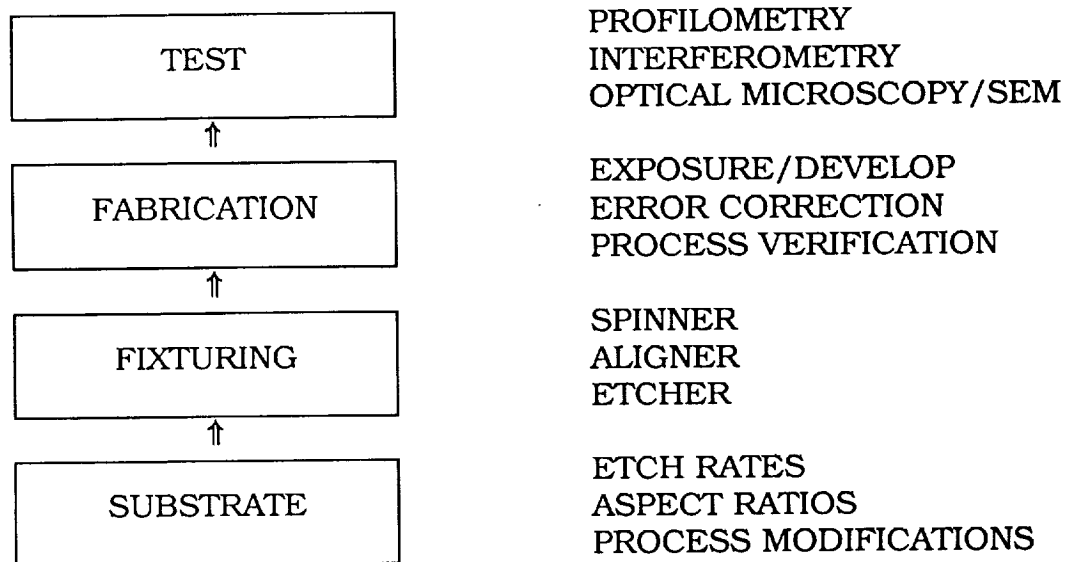
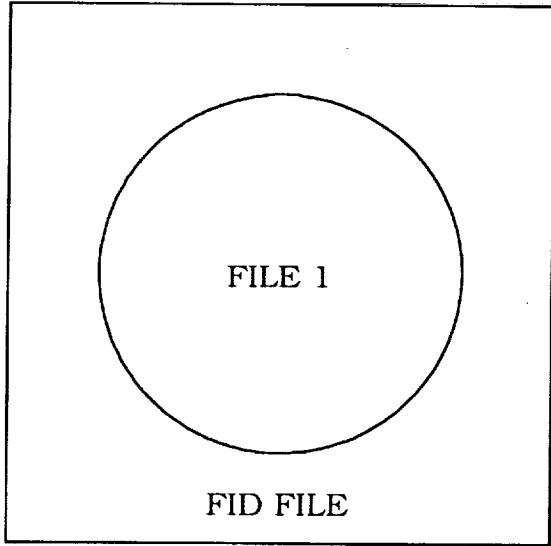
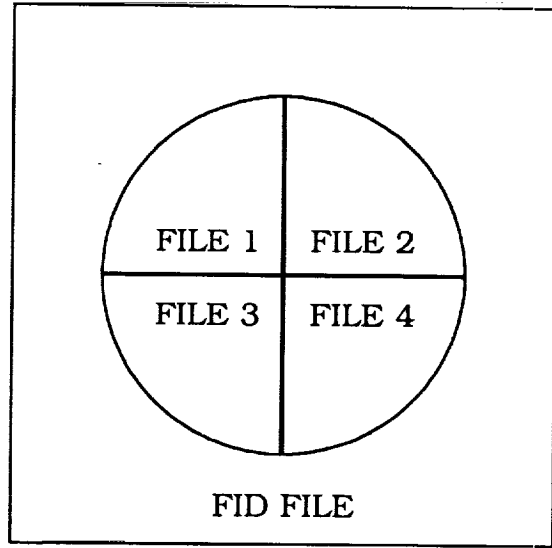

FIGURE 2. BASIC OPTIC FABRICATION PROCESS FLOW



MASKS 1 & 2



MASKS 3 & 4

FIGURE 3. LARGE ASPHERIC LENS DATA PARTITIONS

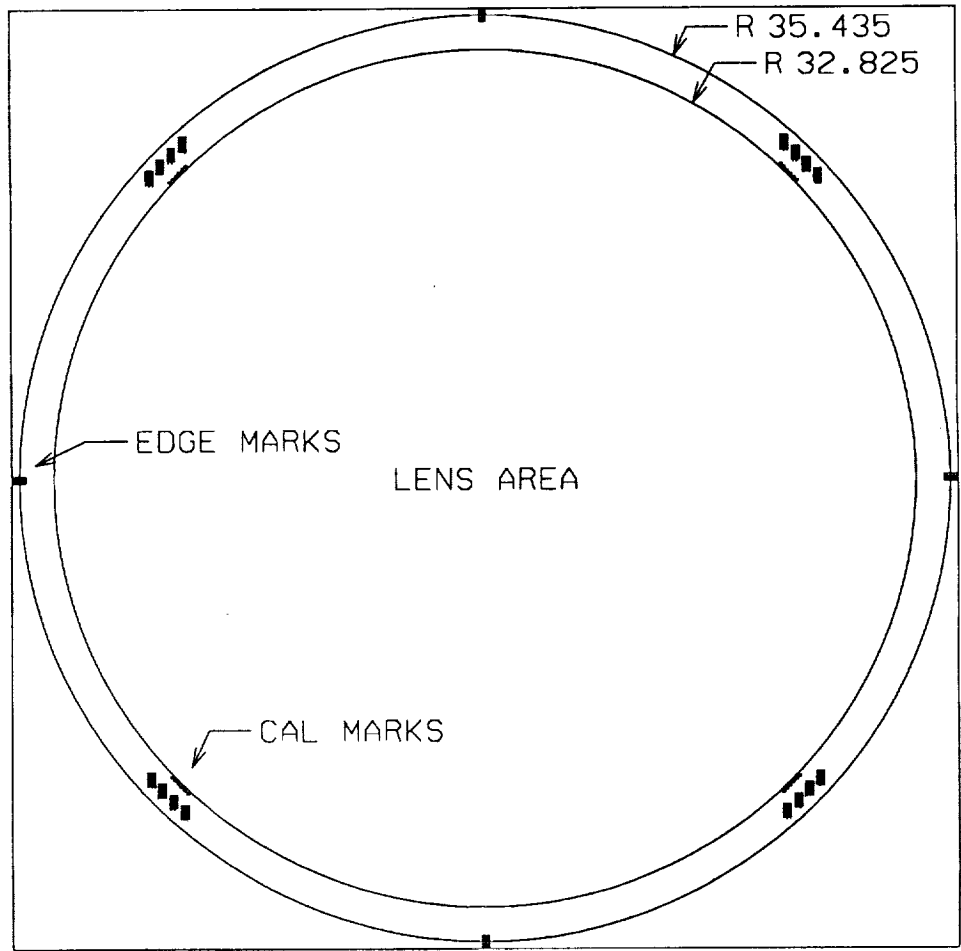
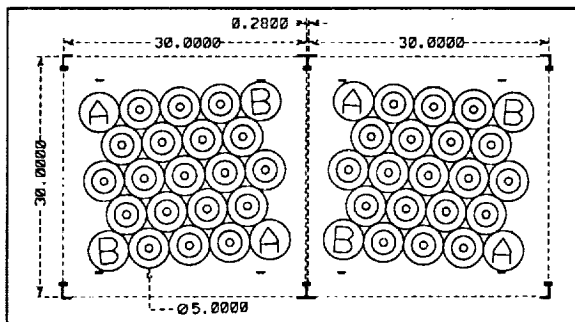
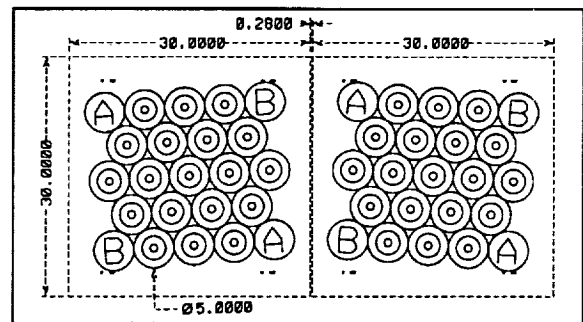

FIGURE 4. SAMPLE MASK LAYOUT FOR A LARGE ASPHERIC LENS



MASK 1



MASK 2

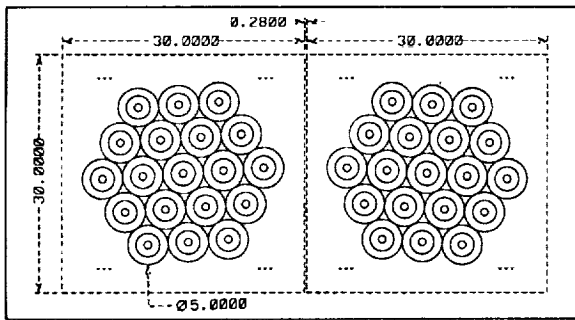

MASK 3

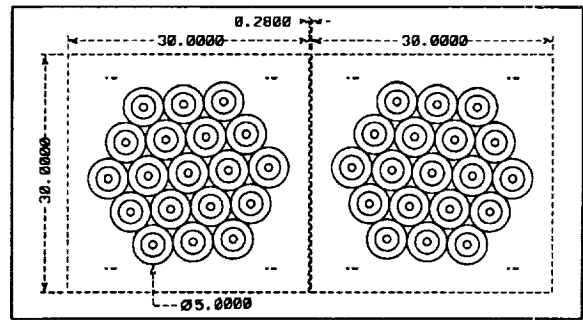

MASK 4

FIGURE 5. MASK LAYOUTS FOR LENSLET ARRAYS

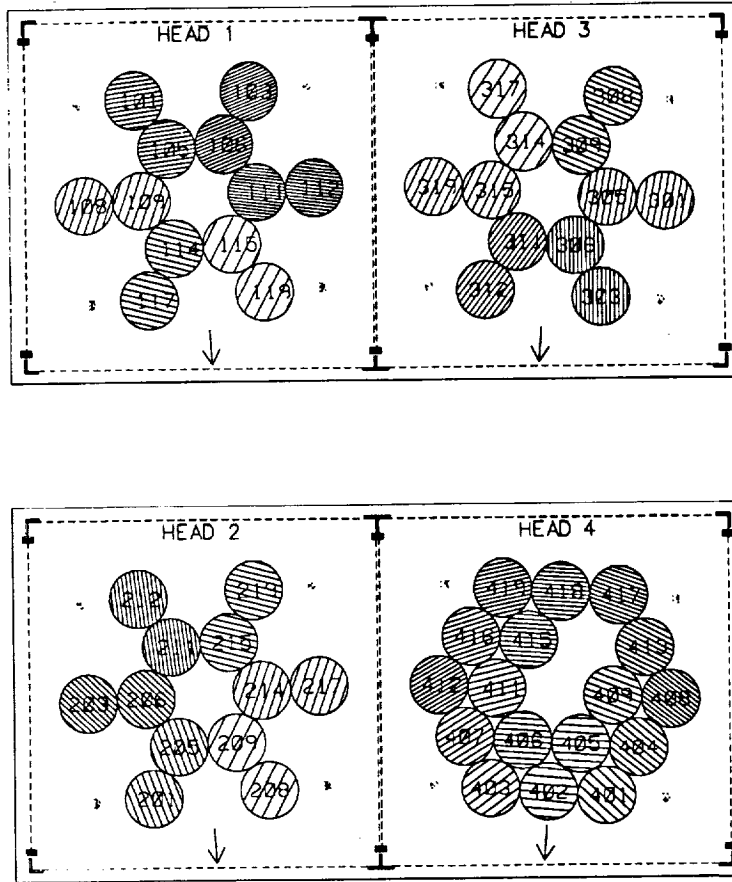

FIGURE 6. MASK LAYOUTS FOR GRATING ARRAYS

