

**1993 NASA-ODU AMERICAN SOCIETY  
FOR ENGINEERING EDUCATION  
(ASEE) SUMMER FACULTY  
FELLOWSHIP PROGRAM**

Compiled by: Surendra N. Tiwari  
ASEE Co-Director

and

Deborah B. Young  
Administrative Assistant

(NASA-CR-191544) THE 1993 NASA-ODU  
AMERICAN SOCIETY FOR ENGINEERING  
EDUCATION (ASEE) SUMMER FACULTY  
FELLOWSHIP PROGRAM Final Report, 7  
Jun. - 13 Aug. 1993 (Old Dominion  
Univ.) 238 p

N94-27893  
--THRU--  
N94-27930  
Unclas

G3/80 0209790



**Old Dominion University  
Norfolk, Virginia**



NASA Contractor Report 191544  
Grant NGT-47-003-029  
December 1993



**1993**

**FINAL ADMINISTRATIVE REPORT**

**NASA/ASEE SUMMER FACULTY FELLOWSHIP PROGRAM**

Langley Research Center  
Hampton, Virginia  
and  
Old Dominion University  
Norfolk, Virginia

**SUBMITTED TO:**

Ms. Sherri McGee  
NASA Headquarters  
Washington, DC

Dr. Samuel E. Massenberg  
Director for Education  
and

Mr. Robert L. Yang  
Assistant University Affairs Officer  
Office of Education  
Langley Research Center  
Hampton, Virginia

**ADMINISTRATIVE STAFF:**

Dr. Surendra N. Tiwari, ASEE Co-Director  
Eminent Professor  
Department of Mechanical Engineering  
Old Dominion University

Ms. Deborah B. Young  
ASEE Administrative Assistant  
Old Dominion University

December 1993



## TABLE OF CONTENTS

		<u>Page</u>
Section I	Organization and Management .....	1
Section II	Recruitment and Selection of Fellows .....	3
	Returning Fellows .....	3
	First Year Fellows .....	3
Section III	Stipend and Travel .....	8
Section IV	1993 ASEE SFFP Activities .....	8
	Lecture Series .....	8
	Picnic .....	8
	Unsolicited Proposal Seminar .....	8
	Seminar/Banquet .....	9
	ASEE Activities Committee .....	9
Section V	Research Participation .....	10
	Fellows by Division .....	10
	Fellows by Degree Area .....	11
	Extensions .....	11
	Attendance at Short Courses, Seminars, and Conferences .....	12
	Papers Presented .....	13
	Anticipated Papers .....	14
	Anticipated Research Proposals .....	15
	Funded Research Proposals .....	16
	Section VI	Summary of Program Evaluation .....
Fellows' Survey .....		18
Fellows' Comments .....		24
Fellows' Recommendations .....		24
Summary of Associates' Evaluation .....		26
Research Associates' Comments .....		26
Research Associates' Recommendations .....		26
Section VII	Conclusions and Recommendations .....	28
	Conclusions .....	28
	Recommendations .....	29
Appendix I	1993 Participants .....	30

	<b><u>Page</u></b>
Appendix II	Technical Lecture Series - Presentations by Research Fellows ..... 34
	Technical Lecture Series ..... 35
	Technical Lecture Series Program Sample ..... 36
	Presentations by Research Fellows ..... 38
Appendix III	Group Picture of Research Fellows ..... 39
	Group Picture ..... 40
	List of Attendees ..... 41
Appendix IV	Distribution of Fellows by Directorate ..... 42
Appendix V	Distribution of Fellows Ethnicity/Female ..... 44
Appendix VI	Distribution of Fellows by Ethnicity/Male ..... 46
Appendix VII	Distribution of Fellows by University Rank ..... 48
Appendix VIII	Distribution of Fellows by University ..... 50
Appendix IX	Sample Questionnaires ..... 52
Appendix X	Abstracts - Research Fellows ..... 64
Appendix XI	Program Orientation Evaluation Report ..... 200
Appendix XII	Unsolicited Proposal Seminar Evaluation Report ... 210
Appendix XIII	Policies, Practices, and Procedures Manual ..... 213

## LIST OF TABLES

<b><u>Table No.</u></b>		<b><u>Page</u></b>
1	Distribution by Year in Program .....	4
2	Distribution by University .....	5
3	Distribution by Selection .....	6
4	Distribution by Funding .....	7

## LIST OF ABSTRACTS - RESEARCH FELLOWS

	<u>Page</u>
HYBRID TECHNIQUES FOR COMPLEX AEROSPACE ELECTROMAGNETICS PROBLEMS by JAMES T. Aberle, Arizona State University	65
RIAD VISUAL IMAGING BRANCH ASSESSMENT by Sherilee F. Beam, Hampton University .....	68
ON IDENTIFIED PREDICTIVE CONTROL by Jan T. Bialasiewicz, University of Colorado .....	71
EFFECTS OF PHYSICAL AGING ON LONG-TERM BEHAVIOR OF COMPOSITES by L. Catherine Brinson, Northwestern University ..	74
PROTON IRRADIATION ON MATERIALS by C. Ken Chang, Christopher Newport University .....	78
A COMPREHENSIVE COMPARISON OF TURBULENCE MODELS IN THE FAR WAKE by John M. Cimbala, Pennsylvania State University	80
AN EXPERIMENTAL INVESTIGATION OF FATIGUE DAMAGE IN ALUMINUM 2024-T3 ALLOYS by Milton W. Ferguson, Norfolk State University .....	83
BRAIN WAVE CORRELATES OF ATTENTIONAL STATES: EVENT RELATED POTENTIALS AND QUANTITATIVE EEG ANALYSIS DURING PERFORMANCE OF COGNITIVE AND PERCEPTUAL TASKS by Frederick G. Freeman, Old Dominion University .....	85
INVESTIGATION OF AERODYNAMIC DESIGN ISSUES WITH REGIONS OF SEPARATED FLOW by Thomas A. Gally, Texas A&M University .....	89
MICROSPHERES FOR LASER VELOCIMETRY IN HIGH TEMPERATURE WIND TUNNEL by Anthony Ghorieshi, Wilkes University .	91
NEW MONOMERS FOR HIGH PERFORMANCE POLYMERS by Roy F. Gratz, Mary Washington College .....	100
NEURAL CONTROL OF MAGNETIC SUSPENSION SYSTEMS by W. Steven Gray, Drexel University .....	102
LOCATING TIE-POINTS ON A GRID by James S. Green, Moravian College .....	104



	<u>Page</u>
SPACECRAFT OPTICAL DISK RECORDER MEMORY BUFFER CONTROL by Robert F. Hodson, Christopher Newport University . . . . .	109
SYSTEM IDENTIFICATION OF THE LARGE-ANGLE MAGNETIC SUSPENSION TEST FACILITY (LAMSTF) by Jen-Kuang Huang, Old Dominion University . . . . .	114
KINETIC PARAMETERS FROM THERMOGRAVIMETRIC ANALYSIS by Richard L. Kiefer, College of William and Mary . . . . .	116
THE MOLECULAR MATCHING PROBLEM by Rex K. Kincaid, College of William and Mary . . . . .	120
A NUMERICAL STUDY OF MIXING AND COMBUSTION IN HYPER-VELOCITY FLOWS THROUGH A SCRAMJET COMBUSTOR MODEL by Ramesh Krishnamurthy, Old Dominion University . . . . .	123
EXPERIMENTAL APPARATUS FOR OPTIMIZATION OF FLAP POSITION FOR A THREE-ELEMENT AIRFOIL MODEL by Drew Landman, Old Dominion University . . . . .	126
AN OVERVIEW ON DEVELOPMENT OF NEURAL NETWORK TECHNOLOGY by Chun-Shin Lin, University of Missouri-Columbia . . . . .	129
MECHANICALLY FASTENED COMPOSITE LAMINATES SUBJECTED TO COMBINED BEARING-BYPASS AND SHEAR LOADING by Erdogan Madenci, University of Arizona . . . . .	130
RADIATIONS FROM HOT NUCLEI by F. Bary Malik, Southern Illinois University . . . . .	137
REVIEW AND ANALYSIS OF DENSE LINEAR SYSTEM SOLVER PACKAGE FOR DISTRIBUTED MEMORY MACHINES by Hira N. Narang, Tuskegee University . . . . .	140
STRATEGIC PLAN FOR EDUCATION by Sandra B. Proctor, Norfolk State University . . . . .	146
WING DESIGN FOR A CIVIL TILTROTOR TRANSPORT AIRCRAFT: A PRELIMINARY STUDY by Masoud Rais-Rohani, Mississippi State University . . . . .	147
A SIMULATION OF GPS AND DIFFERENTIAL GPS SENSORS by James M. Rankin, St. Cloud State University . . . . .	149

	<b><u>Page</u></b>
AERODYNAMIC HEATING IN HYPERSONIC FLOWS by C. Subba Reddy, Virginia State University .....	154
AERONAUTICAL ENGINEERING AS A CONTEXT FOR A COURSE IN MATHEMATICS by George T. Rublein, College of William and Mary	156
DEVELOPMENT OF METHODOLOGIES FOR THE ESTIMATION OF THERMAL PROPERTIES ASSOCIATED WITH AEROSPACE VEHICLES by Elaine P. Scott, Virginia Polytechnic Institute and State University	158
EVALUATION OF HIGH TEMPERATURE SUPERCONDUCTIVE THERMAL BRIDGES FOR SPACE-BORNE CRYOGENIC INFRARED DETECTORS by Elaine P. Scott, Virginia Polytechnic Institute and State University .....	162
ORGANIZATIONAL DEVELOPMENT: A PLANNED CHANGE EFFORT IN THE MANAGEMENT SUPPORT DIVISION AT NASA LANGLEY RESEARCH CENTER by Denise V. Siegfeldt, Florida Institute of Technology .....	166
A TRI-STATE OPTICAL SWITCH FOR LOCAL AREA NETWORK COMMUNICATIONS by Garfield B. Simms, Hampton University . . .	170
A STUDY OF SPACE STATION <u>FREEDOM</u> REDESIGN AND VARIOUS EARTH OBSERVING SATELLITE SYSTEMS by S. Ballou Skinner, University of South Carolina/Coastal Carolina College .....	177
FIBER OPTIC SENSORS FOR CORROSION DETECTION by Alphonso C. Smith, Hampton University .....	179
INVESTIGATION OF SPECTRAL ANALYSIS TECHNIQUES FOR RANDOMLY SAMPLED VELOCIMETRY DATA by Dave Sree, Tuskegee University .....	183
COMPARATIVE ANALYSIS OF DIFFERENT CONFIGURATIONS OF PLC-BASED SAFETY SYSTEMS FROM RELIABILITY POINT OF VIEW by Moez A. Tapia, University of Miami .....	187
PROPERTY ENHANCEMENT OF POLYIMIDE FILMS VIA THE INCORPORATION OF LANTHANIDE METAL IONS by David W. Thompson, College of William and Mary .....	189
ADP ANALYSIS PROJECT FOR THE HUMAN RESOURCES MANAGE- MENT DIVISION by Robert L. Tureman, Paul D. Camp Community College .....	190

**Page**

SPACE TRANSPORTATION VEHICLE DESIGN EVALUATION USING SATURATED DESIGNS by Resit Unal, Old Dominion University . . .	192
PREDICTION OF LEADING-EDGE TRANSITION AND RELAMINARIZATION PHENOMENA ON A SUBSONIC MULTI-ELEMENT HIGH-LIFT SYSTEM by Cornelis P. van Dam, University of California . . . .	194
COMPUTATION OF TRANSONIC VISCOUS FLOW PAST THE NTF 65-DEGREE DELTA WING by Chivey C. Wu, California State University . . . . .	196



## **SECTION 1**

### **ORGANIZATION AND MANAGEMENT**

The 1993 Old Dominion University (ODU)-NASA Langley Research Center (LaRC) Summer Faculty Fellowship Research Program, the thirtieth such institute to be held at LaRC, was planned by a committee consisting of the University Co-Director, LaRC Staff Assistants (SAs) from the research Directorates, and the University Affairs Office (UAO), under the auspices of the Office of Education.

An initial assessment of each applicant's credentials was made by the University Co-Director and the NASA LaRC Assistant University Affairs Officer. The purpose of this assessment was to ascertain to which Division the applicant's credentials should be circulated for review. Once this determination was made, an application distribution meeting was scheduled with the SAs where applications were distributed and instructions concerning the selection process were discussed. At a later date, the SAs notified the ASEE office of the selections made within their Directorate.

The University Co-Director then contacted each selected Fellow by phone extending the individual a verbal appointment, which was followed up with a formal letter of confirmation. Individuals were given ten days to respond in writing to the appointment. Once the letters of acceptance were received, a roster was sent to each SA advising them of their Fellows for the summer program.

Each Fellow accepting the appointment was provided with material relevant to housing, travel, payroll distribution, and the orientation. Each Fellow, in advance of commencing the program, was contacted by his or her Research Associate or representative of the branch.

For the first time with the ASEE program, each Fellow and Research Associate received a 1993.1 ASEE Policies, Practices, and Procedures Manual which clarified many commonly asked questions up front regarding the roles, responsibilities, policies, and procedures of both parties. This manual was very beneficial and will be updated annually to be used in the years to come (Appendix XIII).

At the Orientation meeting, Mr. Edwin J. Prior, Deputy Director for the Office of Education, officially started the first day of the summer program by welcoming everyone to LaRC. He was followed by Mr. Robert L. Yang, Assistant University Affairs Officer, who presented the LaRC and schedule overview. A program breakout session was next on the agenda, enabling the ASEE administrative staff to meet with the 1993 Fellows to discuss administrative procedures and answer any questions that came to mind.

Next, the Fellows were invited to tour several of the LaRC facilities which included the Aircraft Landing Dynamics Facility and the Transonic Dynamics Tunnel. Following the tours, the Fellows returned to the H.J.E. Reid Conference Center where they were greeted by their LaRC Associate who then escorted them to their respective work sites. An evaluation of the orientation meeting was completed; refer to Section VI for results.

Throughout the program, the University Co-Director served as the principal liaison person and had frequent contacts with the Fellows. The University Co-Director also served as the principal administrative officer. At the conclusion of the program, each Fellow submitted an abstract describing his/her accomplishments. Each Fellow gave a talk on his/her research within the Division. The Directorate SAs then forwarded to the Co-Director the names of the Fellows recommended within their Directorate for the Final Presentations. Twelve excellent papers were presented to the Fellows, Research Associates, and invited guests.

Each Fellow and Research Associate was asked to complete a questionnaire provided for the purpose of evaluating the summer program.

## **SECTION II**

### **RECRUITMENT AND SELECTION OF FELLOWS**

#### **Returning Fellows**

An invitation to apply and possibly participate in the Old Dominion University (ODU)-NASA Langley Research Center (LaRC) Program was extended to the individuals who held 1992 fellowship appointments and were eligible to participate for a second year. Twenty-two individuals responded to the invitation and twelve were selected (Table 1). Eight applications were received from Fellows from previous years. Four were selected.

#### **First Year Fellows**

Although ASEE distributed a combined brochure of the summer programs, many personal letters were mailed to deans and department heads of various engineering schools in the East, South, and Midwest, by Dr. Surendra N. Tiwari of Old Dominion University and Mr. John H. Spencer of Hampton University (HU) requesting their assistance in bringing to the attention of their faculties the ODU/HU-NASA LaRC program. In addition to the above, a number of departments of chemistry, physics, computer science, and mathematics at colleges (including community colleges) and universities in the State of Virginia, as well as, neighboring states were contacted regarding this program. Although minority schools in Virginia and neighboring states were included in the mailing, the Co-Director from HU sent over three hundred letters to deans and department heads, and to all of the minority institutions across the United States soliciting participants (Table 2). These efforts resulted in a total of one-hundred and seven formal applications indicating the ODU/HU-NASA LaRC program as their first choice, and a total of fifty-four applications indicating the aforementioned as their second choice. The total number of applications received came to one-hundred sixty-one (Table 3).

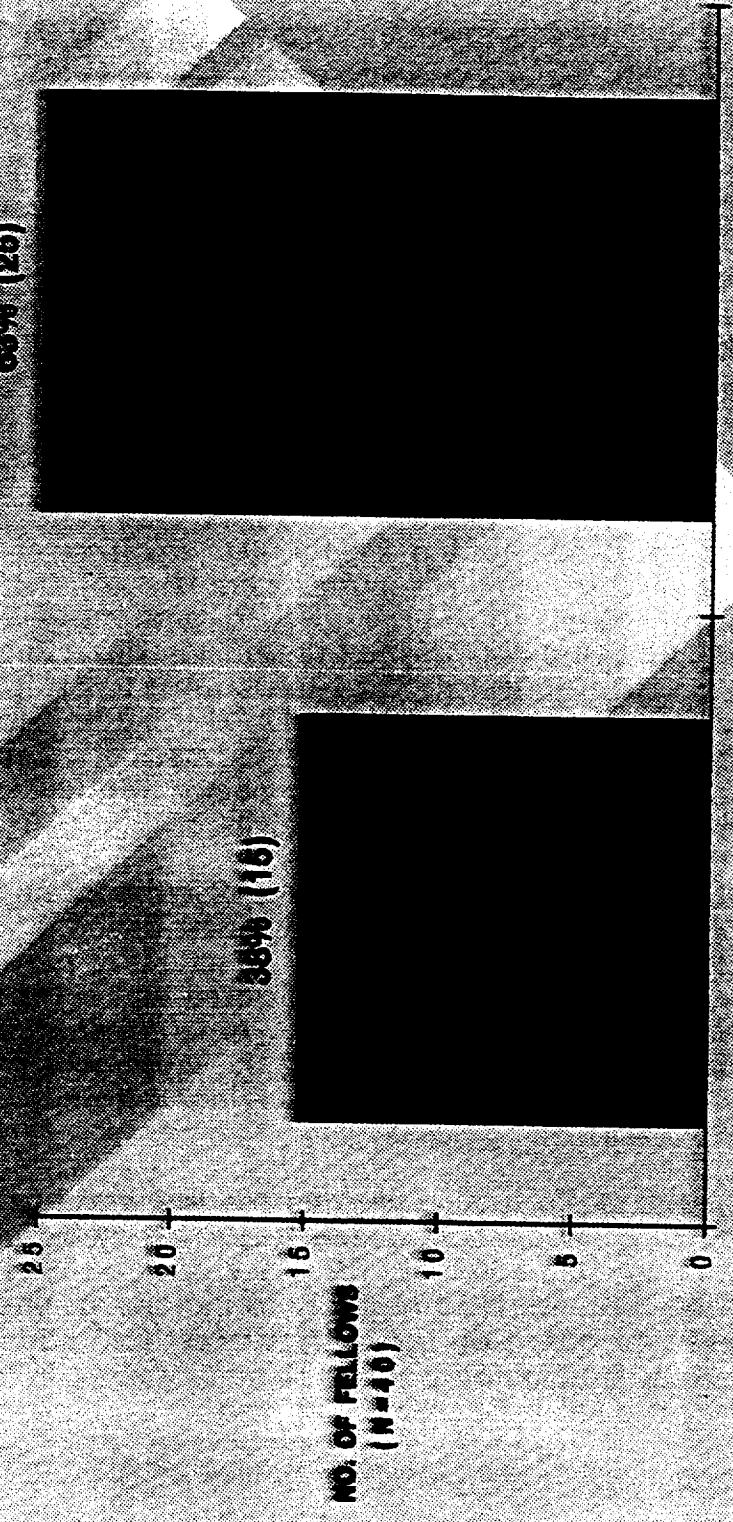
Forty applicants formally accepted the invitation to participate in the program. Four applicants declined the invitation. A few Fellows delayed their response while waiting for other possible offers from other programs. The top researchers tend to apply to more than one program, and will make their selection based on research interest and stipend. Twenty-six positions were initially budgeted by NASA Headquarters. Fourteen positions were funded by the LaRC Divisions (Table 4).

The average age of the participants was 42.6.

# THE I - DIS (INTERDISCIPLINARY) BY THE PROGRAM OF 1993 ASHE

63% (26)

38% (16)



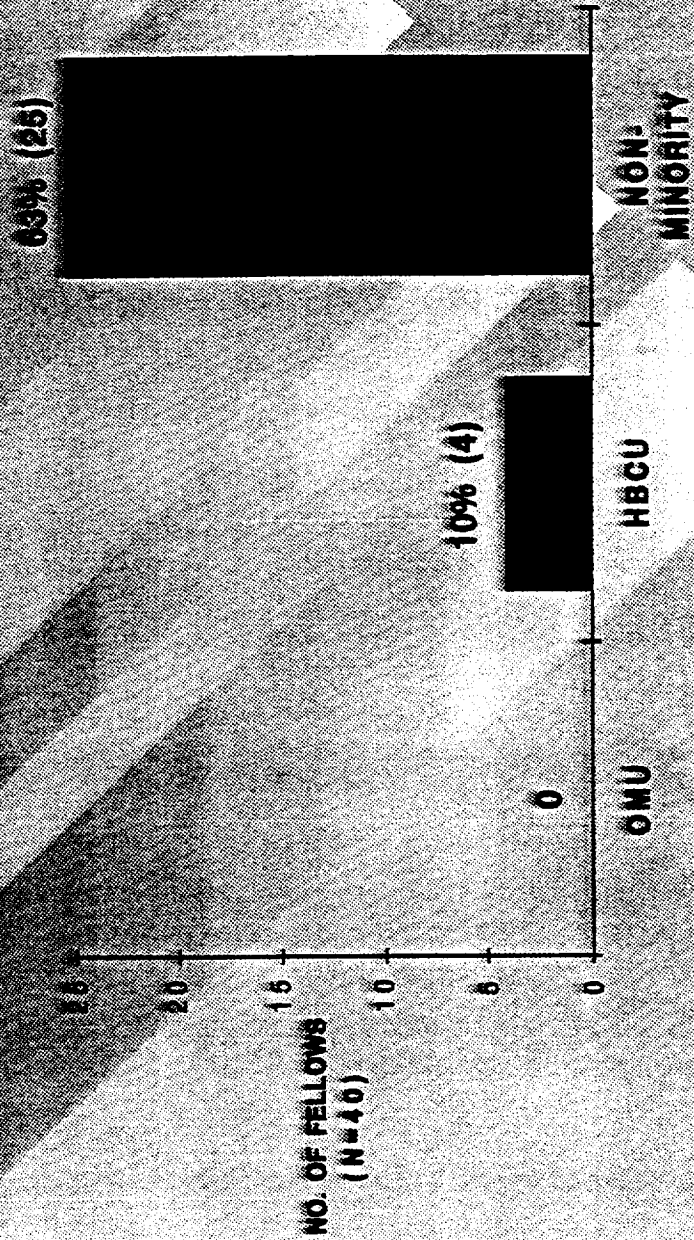
NO. OF FELLOWS  
(N=40)

Returnee

First Year

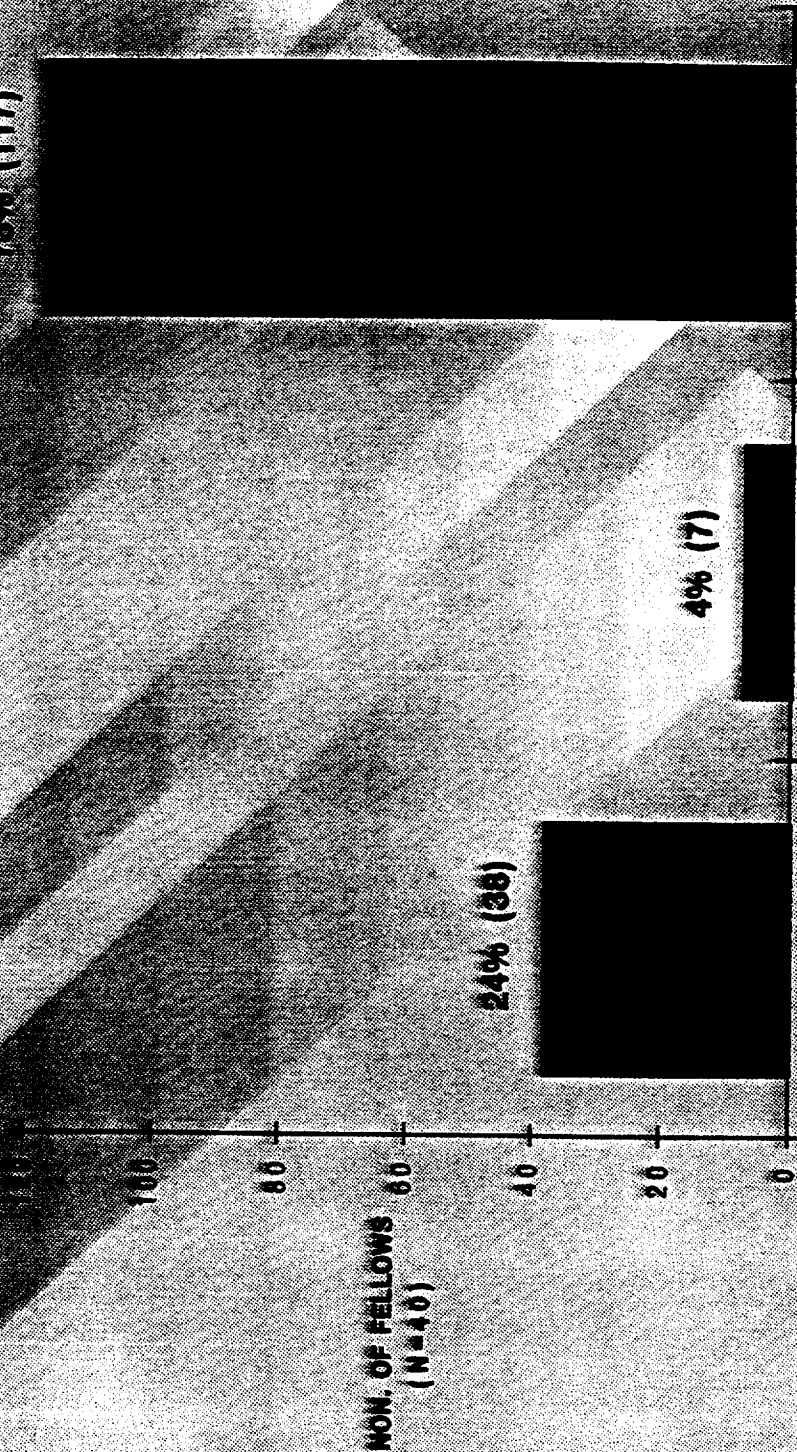
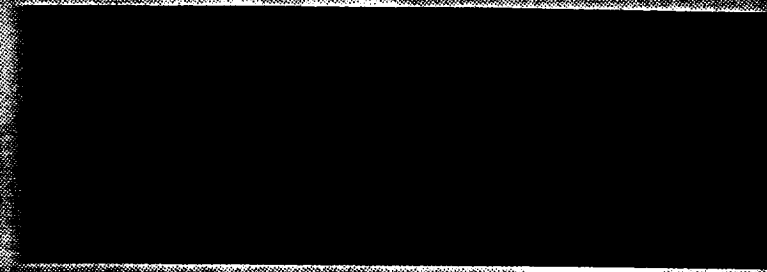


**TABLE 2. DISTRIBUTION OF 1998 FELLOWS (SEE PARAGRAPH 19)**



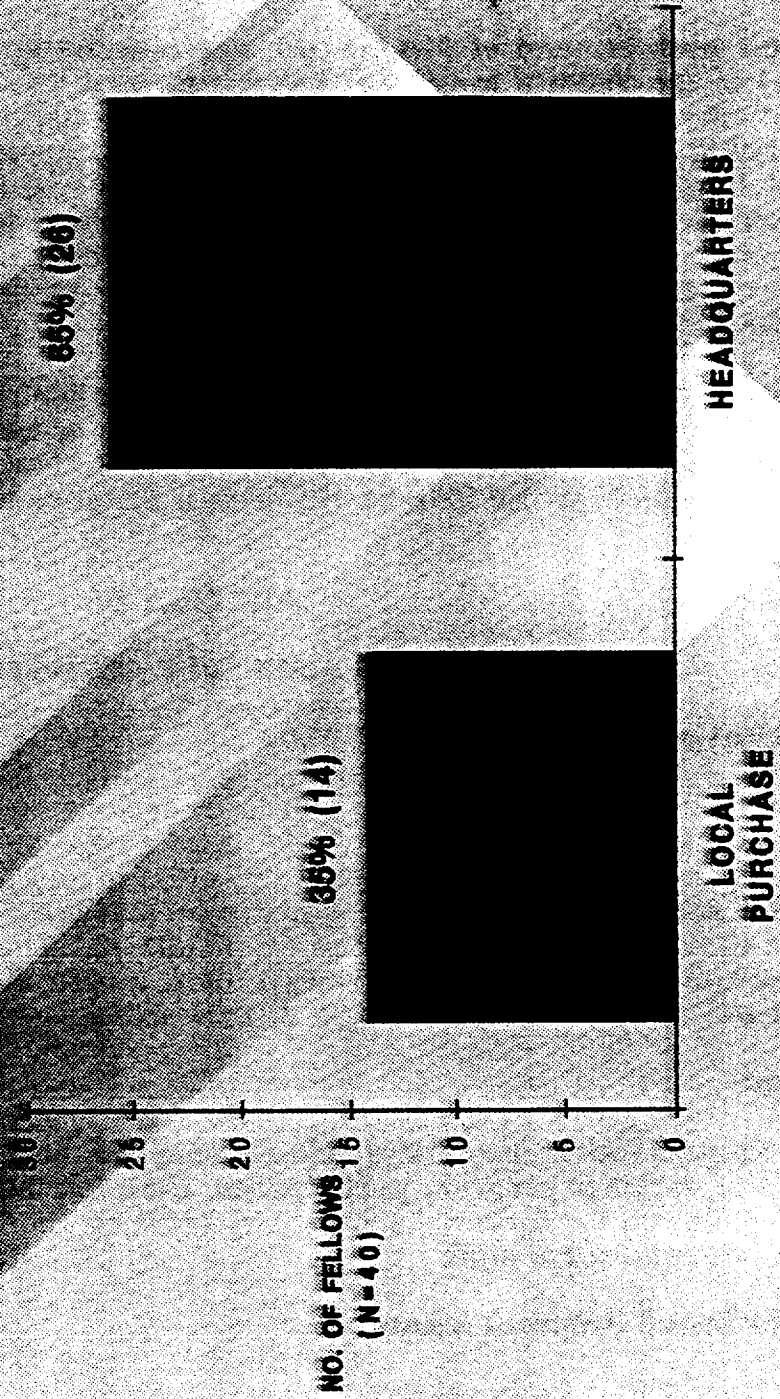
**TABLE 3 - DISTRIBUTION OF  
03 ACADE (SFFP) RECEPTION**

75% (117)



NON. OF FELLOWS  
(N=40)

# TABLE 4 - DISTRIBUTION OF 1993 FEE (SERVICES) FUNDING



## **SECTION III**

### **STIPEND AND TRAVEL**

A ten week stipend of \$10,000.00 was awarded to each Fellow. Although 51% of the Fellows indicated that the stipend was not the primary motivator in their participating in the ASEE program, only 32% indicated this amount as being adequate (Survey-Section VI). This stipend still falls short of matching what most professors could have earned based on their university academic salaries. The decision to participate in the summer faculty research program clearly reflects the willingness of the Fellow to make some financial sacrifice in order to have the experience of working with NASA's finest scientists and researchers.

Mileage or air fare expenses incurred by the Fellows from their institution to Hampton, Virginia, as well as their return trip, were reimbursed in accordance with current ODU regulations. A relocation allowance of \$1,000 was provided for the Fellows traveling a distance of 50 miles or more.

## **SECTION IV**

### **1993 ASEE SFFP ACTIVITIES**

#### **Technical Lecture Series**

Due to the past success, the Technical Lecture Series was again scheduled for this summer's program. There were a total of six lectures with five given by invited Langley scientists and researchers and one given by an outside guest speaker (Appendix II). For the second year, a Program was prepared and distributed at each lecture (Appendix II). The Program included biographical information on the speaker, a brief abstract of the technical lecture, and the announcement of the next lecture.

#### **Picnic**

An annual University Affairs Office picnic was held on Friday, June 25, 1993, for the summer program participants, their families, and invited guests. This allowed for informal interaction between the Fellows, as well as, with the administrative staff.

#### **Unsolicited Proposal Seminar**

An Unsolicited Proposal Seminar was held for the Fellows and invited university guests on Thursday, August 12, 1993. The Assistant University Affairs Officer, Robert L. Yang, along with other invited guest speakers representing NASA and selected universities, presented an overview of the

proper procedures to adhere to in submitting an unsolicited proposal to NASA. The program covered both the NASA and university perspectives. This was the first time this particular forum was used and was received very well by the Fellows and other guests (Appendix XII).

### **Seminar/Banquet**

On Wednesday, July 28, 1993, a seminar/banquet was held for the Fellows and their spouses. The banquet took place at the beautiful Langley Air Force Base Officer's Club. ASEE end of the program information and group pictures were presented to each Fellow at the banquet.

### **ASEE Activities Committee**

An ASEE Activities Committee was formed to plan social outings for the program participants and their families. The head of this committee developed a newsletter to share planned events, as well as local events, festivals, entertainment, and so forth. This was very well received by the Fellows, particularly those from outside the Tidewater area.

## SECTION V

### RESEARCH PARTICIPATION

The ODU-LaRC Summer Research Program, as in past years, placed the greatest emphasis on research aspects of the program. Included in this report are abstracts from the Fellows showing their accomplishments during the summer. These abstracts, together with the comments of the LaRC Research Associates with whom the Fellows worked very closely, provide convincing evidence of the continued success of this part of the program. The Fellow's comments during the evaluation of the program indicated their satisfaction with their research projects, as well as, with the facilities available to them.

The research projects undertaken by the Fellows were greatly diversified as is reflected in their summer research assignments. Their assignments were as follows:

<b>Number of Fellows Assigned</b>	<b>Division</b>
2	Applied Aerodynamics Division
2	Analysis and Computation Division
1	Flight Applications Division
1	Flight Electronics Division
2	Facilities Engineering Division
4	Fluid Mechanics Division
2	Flight Management Division
3	Guidance and Control Division
1	Human Resources Management Division
3	Instrument Research Division
1	Information Systems Division
1	Management Support Division
5	Materials Division
1	Office of Education
1	Research Information and Applications
2	Structural Dynamics Division
1	Space Technology Initiative Office
3	Structural Mechanics Division
3	Space Systems Division
1	Space Station Freedom Office

Thirty-six (90%) of the participants were holders of the doctorate degree. Four (10%) held masters degrees. The group was again highly diversified with respect to background. Following are the areas in which the last degree was earned:

<b>Number</b>	<b>Area of Degree</b>
1	Aeronautics
2	Aerospace Engineering
1	Agricultural and Mechanical Engineering
2	Applied Mechanics
4	Chemistry (includes 1 organic and 1 nuclear)
2	Computer Science
1	Education and Instructional Media
6	Electrical Engineering
1	Electrical Engr. and Automation Control
2	Engineering
1	Engineering Management
1	Engineering Mechanics
1	Estimation and Control
1	Management
2	Mathematics
5	Mechanical Engineering
1	Operations Research
1	Philosophy (Information Science)
3	Physics
1	Psychology
1	Social and Philosophical Foundations of Education

### **Extensions**

A portion of the funds remaining in the travel and relocation budget was used to grant extensions to nine Fellows in the program. To be considered for the extension, the Fellows submitted a statement of justification which was supported by the Research Associate. The requests were reviewed by the University Co-Director and the Assistant University Affairs Officer. The following individuals were granted a one week extension:

Dr. Thomas Gally  
 Dr. Anthony Ghorieshi  
 Dr. Jen-Kuang Huang  
 Dr. Ramesh Krishnamurthy  
 Dr. Erdogan Madenci  
 Dr. Subba Reddy  
 Dr. George Rublein  
 Mr. Robert Tureman  
 Dr. Cornelis Van Dam

## **Attendance at Short Courses, Seminars, and Conferences**

During the course of the summer there were a number of short courses, seminars, and conferences, in which the subject matter had relevance to the Fellows' research projects. A number of Fellows requested approval to attend one or more of these conferences as it was their considered opinion that the knowledge gained by their attendance would be of value to their research projects. Those Fellows who did attend had the approval of both the Research Associate and the University Co-Director.

The following is a listing of those Fellows attending either a short course, seminar, or conference:

**James T. Aberle:** IEEE Antenna and Propagation Society International Symposium, Ann Arbor, MI.

**Frederick G. Freeman:** Seminar on Neural Networks and Fuzzy Logic, NASA Langley Research Center.

**Thomas A. Gally:** AIAA Computational Fluid Dynamics Conference, Orlando, FL.

**J. Anthony Ghorieshi:** Conference on "Potential Impacts of Advanced Aerodynamics Technology on Air Transportation Systems Productivity", NASA Langley Research Center.

**W. Steven Gray:** Seminars on "Nonlinear Flight Control Using Neural Networks and Feedback Linearization", "A Digital Phase-Lead Controller for a Magnetic Levitation System", and "Design of a Neural Network Computer for Control Applications." Short course on "Sliding Mode Control with Gaussian Networks."

**F. Bary Malik:** Invited talks at (1) International Workshop on Condensed Matter Theories, Pakistan, and (2) European Physical Society's Conference on Atomic and Nuclear Clusters, Greece.

**Masoud Rais-Rohani:** Course-Transition to PATRAN 3 for PATRAN 2.5 Users.

**Denise V. Siegfeldt:** Seminar on Diversity 2000: The Challenge of Successfully Managing Our Human Resources, NASA Langley Research Center.

**Garfield B. Simms:** Short Course-Fiber Optics and Optical Detectors.

**Cornelis P. van Dam:** AIAA 29th Fluid Dynamics Conference.



## Papers Presented

**James T. Aberle:** "Hybrid Techniques for Complex Electromagnetics Problems", Applied Computational Electromagnetics Society, IEEE Transactions on Antennas and Propagation.

**Sherilee F. Beam:** "Research Information and Applications Division Visual Imaging Branch Assessment" (inter-division), NASA Langley Research Center.

**L. Catherine Brinson:** "Effects of Physical Aging on Long-Term Behavior of Composites."

**John M. Cimbala:** Submitted "A Comprehensive Comparison of Turbulence Models in the Far Wake" to American Physical Society Division of Fluid Mechanics Annual Meeting, Albuquerque, NM.

**Frederick G. Freeman:** Submitted "Event Related Potentials to Attended and Unattended Stimuli During a Vigilance Task" to the Neuroscience Society.

**J. Anthony Ghorieshi:** "Microspheres for Laser Velocimetry in High Temperature Wind Tunnels."

**W. Steven Gray:** "Gain Scheduling Controllers for a Magnetic Levitation System", by D. Lane, W. S. Gray, and O. Gonzalez, 1994 IEEE ACC; "Sliding Mode Controllers for a Magnetic Levitation System", by R. McConnell, W. S. Gray, and O. Gonzalez, 1994 IEEE ACC; "Controllers for a 2-D Magnetic Levitation System", by W. S. Gray and O. Gonzalez, 1994 IEEE ACC.

**Robert F. Hodson:** "An ASIC Memory Buffer Controller for a High-Speed Disk System", 5th Annual NASA Symposium on VLSI Design, Albuquerque, NM.

**Jen-Kuang Huang:** "Identification of Linear Unstable Systems from Closed-Loop Data", AIAA Structures, Structural Dynamics, and Materials Conference, 1994.

**Rex K. Kincaid:** "The Molecular Matching Problem", ORSA/TIMS CSTS Conference, Jan. 1994.

**Ramesh Krishnamurthy:** "A Numerical Study of Mixing a Combustion in Hypervelocity Flows Through a Scramjet Combustor Model", AIAA Conference, 1994.

**Erdogan Madenci:** "Mechanical Joints Subjected to Combined Bearing-Bypass and Shear Loadings", AIAA Journal.

### **Papers Presented (Continued):**

**F. Bary Malik:** "Equations for Pair Correlation Function for a Finite Fermion System", accepted for publication in Condensed Matter Theories, Vol. 9. "Emission of Clusters from Hot Nuclei", Zeitschrift fur Physik.

**Sandra B. Proctor:** NASA Langley's "Strategic Plan for Education."

**Masoud Rais-Rohani:** "Wing Design for the Civil Tiltrotor Transport Aircraft: A Preliminary Study", abstract submitted to the 35th AIAA/ASME/ASCE/AHS/ASC Structures, Structural Dynamics, and Materials Conference.

**James M. Rankin:** "GPS and Differential GPS: An Error Model for Sensor Simulation", 1994 IEEE Position, Location, and Navigation Symposium (PLANS).

**Denise V. Siegfeldt:** "Organizational Development: A Planned Change Effort in the Management Support Division of NASA Langley Research Center", to be submitted to the Association of Management.

**Dave Sree:** "On the Measurement of Turbulent Spectra From Non-Poisson Distributed Randomly Sampled Laser Velocimetry Data", AIAA Meeting, 1994. "Spectral Enhancement of Randomly Sampled Signals by Pre-Filtering Techniques", ASME Fluids Engineering Conference, Lake Tahoe, 1994.

**Resit Unal:** "Design for Quality Using Response Surface Methods", submitted to Engineering Management Journal. "Aerodynamic Configuration Design Using Response Surface Methods", AIAA Aircraft Design Conference, 1993.

**Cornelis P. van Dam:** Conference paper, AIAA paper no. 93-3140, AIAA 29th Fluid Dynamics Conference, 1993. Conference paper, AIAA paper no. 93-3533, AIAA Applied Aerodynamics Conference, 1993.

### **Anticipated Papers**

**John M. Cimbala:** Plans to submit a journal paper on results of research.

**Hira N. Narang:** Plan to submit a NASA technical report on results of research.

**C. Subba Reddy:** "Aerodynamic Heating in Hypersonic Flows-Experimental Data Reduction", to be submitted to a conference.

### **Anticipated Papers (Continued):**

**George T. Rublein:** Will be publishing a book entitled, "Mathematics for Powered Flight."

**Alphonso C. Smith:** SPIE - Smart Materials and Structures Conference.

**Robert L. Tureman:** Working on a paper for submission to ACM SIGCSE.

**Cornelis P. van Dam:** Preparing a journal article to be submitted to the Journal of Aircraft.

### **Anticipated Research Proposals**

**James T. Aberle:** "Hybrid Techniques for Complex Aerospace Electromagnetics Problems", NASA AMRB.

**Sherilee F. Beam:** Cooperative agreement between Hampton University and LaRC RIAD.

**L. Catherine Brinson:** "Modelling of Long-Term Effects of Chemical and Physical Aging of Polymer Composites", NASA.

**Thomas A. Gally:** "Investigation into Design Methodologies for Airfoils/Wings at Separated or Near-Separated Flight Conditions", NASA LaRC.

**W. Steven Gray:** "Feedback Linearizing Controllers for Guidance, Homing, and Intercept Problems", NASA LaRC, Guidance and Control Division.

"Nonlinear Controllers for a 2-D Magnetic Levitation System", National Science Foundation, Engineering Systems Division.

**Robert F. Hodson:** "SODR Memory Buffer Control ASIC", Christopher Newport University.

**Drew Landman:** Submitted an informal proposal to NASA LaRC.

**Erdogan Madenci:** "Analysis of Mechanical Joints with Multi-Fasteners", NASA LaRC.

**F. Bary Malik:** Preparing a proposal for submission to NASA LaRC.

**Hira N. Narang:** Submitting proposals to DOE and NASA.

**Masoud Rais-Rohani:** "Wing Design for the Civil Tiltrotor Transport Aircraft", to be submitted to NASA LaRC.

### **Anticipated Research Proposals (Continued):**

**James M. Rankin:** "Validation of GPS Error Models", NASA LaRC. "Spatial Error Correlation in GPS", NASA LaRC.

**C. Subba Reddy:** "Aerodynamic Heating in Hypersonic Flows-Experimental Data Reduction", NASA LaRC.

**George T. Rublein:** Interdisciplinary Curricula Materials, National Science Foundation.

**Alphonso C. Smith:** "Evaluation of High Temperature Alloy Materials for Use in Diesel Engines' Cylinder Heads", Department of the Army.

**Dave Sree:** " Investigation of Spectral Analysis Techniques and Turbulence Scales for Randomly Sampled Laser Velocimetry Data", NASA LaRC.

**Resit Unal:** "Multidisciplinary Design Optimization for Space Transportation Vehicles", NASA LaRC.

**Cornelis P. van Dam:** "Study of the Mutual Interaction Between a Wing Wake and An Encountering Airplane", NASA LaRC.

### **Funded Research Proposals**

**L. Catherine Brinson:** "Constitutive Modelling of Shape Memory Alloys", National Science Foundation.

**C. Ken Chang:** "Shielding From Space Radiations", NASA LaRC.

**Frederick G. Freeman:** "EEG and Vigilance Task Performance", NASA.

**W. Steven Gray:** "Neural Control of Magnetic Suspension Systems for Aerospace Applications", NASA LaRC.

**Jen-Kuang Huang:** "Identification and Control of Large-Angle Magnetic Suspension Test Facility", NASA LaRC.

**F. Bary Malik:** "XVI. Condensed Matter Theories", Army Research Office. "XVIII. Nathiagali Summer College", National Science Foundation.

## **SECTION VI**

### **SUMMARY OF PROGRAM EVALUATION**

A program evaluation questionnaire was given to each Fellow and to each Research Associate involved with the program. A sample of each questionnaire is in Appendix IX of this report. The questions and the results are given beginning on the next page 32 of 40 evaluations were returned (80%).

**A. Program Objectives**

1. Are you thoroughly familiar with the research objectives of the research (laboratory) division you worked with this summer?

Very much so	<u>24</u>	(75%)
Somewhat	<u>7</u>	(22%)
Minimally	<u>1</u>	(3%)

2. Do you feel that you were engaged in research of importance to your Center and to NASA?

Very much so	<u>31</u>	(97%)
Somewhat	<u>0</u>	
Minimally	<u>1</u>	(3%)

3. Is it probable that you will have a continuing research relationship with the research (laboratory) division that you worked with this summer?

Very much so	<u>27</u>	(84%)
Somewhat	<u>5</u>	(16%)
Minimally	<u>0</u>	

4. My research colleague and I have discussed follow-up work including preparation of a proposal to support future studies at my home institution, or at a NASA laboratory.

Yes 26 (81%)      No 6 (19%)

5. What is the level of your personal interest in maintaining a continuing research relationship with the research (laboratory) division that you worked with this summer?

Very much so	<u>31</u>	(97%)
Somewhat	<u>1</u>	(3%)
Minimally	<u>0</u>	

**B. Personal Professional Development**

1. To what extent do you think your research interests and capabilities have been affected by this summer's experience? You may check more than one.

Reinvigorated	<u>16</u>	(50%)
Redirected	<u>11</u>	(34%)
Advanced	<u>20</u>	(63%)
Just maintained	<u>2</u>	(6%)
Unaffected	<u>          </u>	

2. How strongly would you recommend this program to your faculty colleagues as a favorable means of advancing their personal professional development as researchers and teachers?

With enthusiasm	<u>25</u>	(78%)
Positively	<u>7</u>	(22%)
Without enthusiasm	<u>          </u>	
Not at all	<u>          </u>	

3. How will this experience affect your teaching in ways that will be valuable to your students? You may check more than one.

By integrating new information into courses	<u>23</u>	(72%)
By starting new courses	<u>2</u>	(6%)
By sharing your research experience	<u>24</u>	(75%)
By revealing opportunities for future employment in government agencies	<u>10</u>	(31%)
By deepening your own grasp and enthusiasm	<u>14</u>	(44%)
Will affect my teaching little, if at all	<u>1</u>	(3%)

4. Do you have reason to believe that those in your institution who make decisions on promotion and tenure will give you credit for selection and participation in this highly competitive national program?

Yes 25 (78%) No 5 (16%) Maybe 2 (6%)

**C. Administration**

1. How did you learn about the Program? Check appropriate response.

Received announcement in the mail	<u>17</u>	(53%)
Read about in a professional publication	<u>1</u>	( 3%)
Heard about it from a colleague	<u>14</u>	(44%)
Other (Explain below)	<u>3</u>	( 9%)
<u>Previous participation</u>		
<u>At a conference from NASA scientists</u>		

2. Did you also apply to other summer faculty programs?

Yes 9 (28%) No 23 (72%)

<u>1 ( 3%)</u>	DOE
<u>5 (16%)</u>	Another NASA Center
<u>3 ( 9%)</u>	Air Force
<u>4 (13%)</u>	Army
<u>5 (16%)</u>	Navy

3. Did you receive an additional offer of appointment from one or more of the above? If so, please indicate from which.

Yes \_\_\_\_\_ No 32 (100%)

4. Did you develop new areas of research interests as a result of your interaction with your Center and laboratory colleagues?

Many	<u>9</u>	(28%)
A few	<u>23</u>	(72%)
None	_____	

5. Would the amount of the stipend (\$1,000 per week) be a factor in your returning as an ASEE Fellow next summer?

Yes 22 (69%) No 10 (31%)

If not, why? Interest is in doing research; Reasonable, could be a little higher; Adequate, but not primary concern; Relocation allowance could be a little higher due to the cost of relocating a family; More money tends to attract higher paid senior professors from "Big name



institutions” which would drive out the junior faculty and those from smaller schools; I’ve learned a lot even though the stipend was a pay cut; Should be differences in salary for different level professors; the quality of the work and the possibility of pursuing funded work is more important.

6. Did you receive any informal or formal instructions about submission of research proposals to continue your research at your home institution?

Yes   25   (78%)      No   7   (22%)

7. Was the housing and programmatic information supplied prior to the start of this summer’s program adequate for your needs?

Yes   24   (75%)      No   2   (6%)      N/A (19%)

8. Was the contact with your research colleague prior to the start of the program adequate?

Yes   29   (91%)      No   3   (9%)

9. How do you rate the seminar program?

Excellent	<u>  8  </u>	(25%)
Very good	<u> 19 </u>	(59%)
Good	<u>  5 </u>	(16%)
Fair	<u>     </u>	
Poor	<u>     </u>	

10. In terms of the activities that were related to your research assignment, how would you describe them on the following scale?

Activity	Time Was			
	Adequate	Too Brief	Excessive	Ideal
Research	10 (31%)	8 (25%)	0	13 (44%)
Lectures	22 (69%)	1 ( 3%)	4 (13%)	5 (16%)
Tours	15 (47%)	10 (31%)	1 ( 3%)	4 (13%)
Social/Recreational	22 (69%)	2 ( 6%)	0	6 (19%)
Meetings	26 (78%)	1 ( 3%)	0	3 ( 9%)

11. What is your overall evaluation of the program?

Excellent	<u>25</u>	(78%)
Very good	<u>6</u>	(19%)
Good	<u>1</u>	( 3%)
Fair	<u>        </u>	
Poor	<u>        </u>	

12. If you can, please identify one or two significant steps to improve the program.

See Fellows' Comments and Recommendations

13. For second-year Fellows only. Please use this space for suggestions on improving the second year.

See Fellows' Comments and Recommendations

#### D. Stipend

1. To assist us in planning for appropriate stipends in the future, would you indicate your salary at your home institution?

\$ 47,800 per Academic year 28 or Full year 1.  
 Median Range (97%) (1%)

2. Is the amount of the stipend the primary motivator to your participation in the ASEE Summer Faculty Fellowship Program?

Yes 1 (3%) No 17 (53%) In Part 14 (44%)

3. What, in your opinion, is an adequate stipend for the ten-week program during the summer of 1994?

\$10K-9 (32%); \$11-3 (11%); \$12K-10 (36%); \$13K-2 (7%); \$14K-1 (4%); \$15K-3 (11%); Should be based on a percentage of academic salary; Should be based on academic rank and meet or exceed normal salary.

**E. American Society for Engineering Education (ASEE) Membership Information**

1. Are you currently a member of the American Society for Engineering Education?

Yes 9 (28%)                      No 23 (72%)

2. Would you like to receive information pertaining to membership in the ASEE?

Yes 20 (63%)                      No 11 (34%)

Not applicable to professional field 1 (3%)

## **Fellows' Comments**

The ASEE program has been an excellent experience for me. It is extremely well organized and administered. It provided a unique opportunity to focus my long term research interests and to secure funding support. The ASEE program is an excellent example of where the Federal Government, and NASA in particular, has made an important contribution to keeping American technology and science first rate. I strongly recommend this program to all of my academic colleagues. This program has been valuable in finding support for my graduate students and motivating them to do quality research. The program has a wonderful staff. Provides a good opportunity for faculty and researchers to work together. The end of the year seminar/banquet was a nice closing activity and it could be expanded more. A great summer-thank you for the wonderful opportunity. An excellent program that is well supported by NASA and ODU. Congratulations to Dr. Tiwari, Ms. Debbie Young, and all the other people who have made this such an enjoyable experience. This program has helped me to bridge the gap from mechanical design to experimental fluid mechanics. Thanks for a great opportunity. The best and most enjoyable part of the program is the research interaction with colleagues in the laboratory. It was a very stimulating summer. I hate to leave. Everyone has been cooperative, cordial, and helpful. This project is well underway and I would not have made anything like this progress without the persistent help of a lot of people here. In terms of housing opportunities, the list of rooms to rent was great! Please continue that! It is so much easier and nicer than an empty apt. or hotel room. Restricted hours are understandable, but unfortunate. Excellent program-keep it the same. I can think of no needed improvements. Flexibility is very important and the leadership's attitude towards research was the determining factor for this year's excellent management.

## **Fellows' Recommendations**

- Strongly recommend incorporating a formal mechanism, within the ASEE program, for bringing and supporting graduate students because it is likely the student will participate in future projects supported by the Center.
- Encourage ASEE staff to visit participants' home institutions to raise the faculty awareness of the ASEE program and to see if there are universities which will benefit more than others. It seems as if the same universities participate over and over and they are the only ones to benefit.
- It would be nice to meet other faculty members and their families earlier in the program. Provide better opportunities to meet by introductions at the picnic and organizing other family oriented social functions.
- Go back to the luncheons after the lectures.

- Hold the grants workshop earlier so ideas can be incorporated during the summer.
- 1) Instead of presentations at the end of the session, give a status report half way through or just publish a list of papers and have interested parties contact researchers. 2) Eliminate the presentations at the end of the program due to time needed to wrap up research.
- Possibly send the stipend checks through the mail or have at the lectures.
- Please send a copy of the report indicating the results the teacher from New York obtained as a result of his survey.
- Ten weeks is a very short time for doing research, so I would like to see that some of the activities be reduced or even skipped so that we can concentrate on research work: Skip orientation and tours and reduce the number of lectures.
- Have cookies, donuts, and coffee at all seminars.
- Let participants know of extensions earlier.
- Solve the problem of funding new grants by setting aside a sum of money (preferably as a part of the ASEE program) to be used as “seed money” to facilitate the funding of new grants.
- 1) Increase the program to 14 or 15 weeks and allow longer hours.  
2) Allow after hours work.
- Allow more flexibility with regard to time period, especially for 2nd or 3rd year Fellows-10 weeks is a long time to be away from graduate students.
- Announce short courses and eminent guest lectures in a newsletter to ASEE members.
- A visit with Fellows from other Centers would be interesting.
- Provide more travel/relocation funds. Have taxes withheld.
- Combine the lectures with a tour of the facility.
- Organize the activities committee the first day.
- Expose 2nd year Fellows to other potential sponsors.
- Arrange visits for Fellows to visit each others sites to see first hand the research being done.

## **SUMMARY OF ASSOCIATES' EVALUATION**

The following comments and recommendations were taken from the questionnaire distributed to the ASEE Associates requesting them to evaluate the overall performance of their ASEE Fellow. Most all of the Associates responding indicated an overwhelming satisfaction with the Fellow's knowledge of their subject, diligence, interest in assignment, and enthusiasm.

### **Research Associates' Comments**

Did considerable background work prior to arrival and will receive a grant, funding permitting.

This program is very valuable to me. It gives me the opportunity to work with new university faculty and to extend my branch's external activities and contacts.

Exceptionally prepared for work to be done. As a result of research done, a design was submitted for fabrication. We hope to fund a follow-on grant.

Outstanding technical expertise-a significant asset to the research area of interest. It is unusual to have such a close match in objectives/knowledge.

I have and wish to continue devoting part of my efforts to the ASEE program during the summers.

Progressed beyond my expectations-he had a huge task before him.

It seemed to work very well-Bob Yang was super in helping us through the paperwork.

Fellow had excellent capability technically and interfaced with Branch well. Made system work without a flaw. Was very well prepared for his assignment.

### **Research Associates' Recommendations**

- I like the program the way it is.
- Make it 12 weeks.
- Develop some activities for the families of the Fellows.
- Recommend less time spent on seminars, tours, paperwork, and more time in the lab.

- A pot of “seed” money should be available to fund startup grants until regular program funds can be obtained.
- It would be nice if all Fellows could get a list of other Fellows early and also, have the picnic earlier so they can meet and get to know each other.
- There should be a mechanism for NASA scientist to spend time in industry/university (short-term) just like this summer fellowship program.

## SECTION VII

### CONCLUSIONS AND RECOMMENDATIONS

#### Conclusions

Comments from the Research Fellows and the Research Associates, indicate a continued high level of satisfaction with the program. The Fellows feel that the research is important to them in terms of professional growth, and important to the Center and NASA as a whole. The Associates indicated the importance of the research to the Center, and 100% of those responding stated they were very interested in serving as a Research Associate again in the future (28 out of 40 responded-70%).

Early communication, prior to the start of the program between the Fellow and the Associate, enabled 75% of the Fellows to feel they were thoroughly familiar with the research objectives of their Division.

The probability of continued research relationships is up to 84%, which is a twelve percent jump over 72% in 1992 and a seventeen percent increase over 1991. Eighty-one percent of the Research Fellows discussed follow-up work and submitted proposals for future research which is an increase over 1992 (78%) and 1991 (71%).

Personal interest on the part of the Research Fellow in maintaining a continuing research relationship with their research Division remained at 97% for the second year.

Statements from the Fellows indicate that the amount of the stipend is not the important factor when deciding to participate in the program.

Communication between the Associate, Fellow, and administrative staff improved as a result of the 1993.1 Policies, Practices, and Procedures Manual, and as a result of pre-program contact. Ninety-six percent of the Associates indicated their Fellow was adequately prepared for their research assignment.

Most comments from both the Fellows and the Research Associates were positive. The two main recurring comments were:

- (1) Allow more flexibility regarding the hours worked, i.e.-after hours and weekend access and,
- (2) Allow for a more flexible start and end date for the Fellows.



## **Recommendations**

### **A. Program Office**

Certain recommendations that are primarily the responsibilities of the Program Office are listed below:

1. Continue to encourage pre-program contact between the Fellows and Associates. The contacts should occur between March and May.
2. Continue with the distribution of the Policies, Practices, and Procedures Manual which will be updated annually (provided on the day of Orientation).
3. Make Fellows aware of the Technical Library's capability to do extensive computer literature searches. This information is available in the Policies, Practices, and Procedures Manual.

### **B. Research Organizations**

The following recommendations pertain to different research units at LaRC.

1. Establish a work area with necessary supplies and equipment prior to the Fellow's arrival (by the third or fourth week in May).
2. Arrange for required computer access by the Research Fellow (during the first week of arrival of the Fellows).
3. Encourage Fellows to bring their Graduate Students and/or Research Assistants to LaRC for a convenient time period.

### **C. Improvements in Programs/Activities**

Attempts should be made for continuous improvements of activities and plans to make the program meaningful and effective. Certain pilot activities should be initiated to improve the program and services. The present recommendation is to revise the questionnaires provided to Fellows and Associates to obtain specific information for statistical evaluations.

**APPENDIX I**  
**PARTICIPANTS - ASEE/NASA LANGLEY**  
**SUMMER FACULTY RESEARCH PROGRAM**

## 1993 NASA Langley ASEE Summer Faculty Fellowship Program Participants

### Name and Institution

James T. Aberle  
Arizona State University

Sherilee F. Beam (R)  
Hampton University

Jan T. Bialasiewicz  
University of Colorado-Denver

L. Catherine Brinson  
Northwestern University

C. Ken Chang  
Christopher Newport University

John M. Cimbala  
Pennsylvania State University

Milton W. Ferguson (R)  
Norfolk State University

Frederick G. Freeman  
Old Dominion University

Thomas A. Gally  
Texas A&M University

Anthony Ghorieshi (R)  
Wilkes University

Roy F. Gratz  
Mary Washington University

William S. Gray (R)  
Drexel University

James S. Green  
Moravian College

Robert F. Hodson (R)  
Christopher Newport University

Jen-Kuang Huang  
Old Dominion University

### NASA Associate and Division

Fred B. Beck  
Guidance and Control

Jerry Hansbrough  
Research Info & Applications

Lucas G. Horta  
Structural Dynamics

Thomas S. Gates  
Materials

Wayne S. Slemp  
Materials

Ajay Kumar  
Fluid Mechanics

Min Namkung  
Instrument Research

Alan T. Pope  
Flight Management

James M. Luckring  
Applied Aerodynamics

Warren C. Kelliher  
Facilities Engineering

Paul M. Hergenrother  
Materials

Pamela J. Haley  
Information Systems

Kathy Stacy  
Analysis and Computation

Thomas A. Shull  
Flight Electronics

Nelson J. Groom  
Guidance and Control

**Name and Institution**

Richard L. Kiefer  
College of William and Mary

Rex Kincaid (R)  
Purdue University

Ramesh Krishnamurthy  
Old Dominion University

Drew Landman  
Old Dominion University

Chun-Shin Lin  
University of Missouri-Columbia

Erdogan Madenci  
University of Arizona

Fazley B. Malik (R)  
S. Illinois University-Carbondale

Hira N. Narang  
Tuskegee University

Sandra B. Proctor  
Norfolk State University

Masoud Rais-Rohani  
Mississippi State University

James M. Rankin  
St. Cloud State University

C. Subba Reddy  
Virginia State University

George T. Rublein  
College of William and Mary

Elaine P. Scott  
VA Tech Institute and State University

Denise V. Siegfeldt (R)  
Troy State University-Naval Base

**NASA Associate and Division**

Sheila T. Thibeault  
Materials

Jaroslav Sobieski  
Structural Dynamics

Griffin Y. Anderson  
Fluid Mechanics

John C. Lin  
Fluid Mechanics

Edwin B. Dean  
Space Tech. Initiative Office

James H. Starnes  
Structural Mechanics

Lawrence W. Townsend  
Space Systems

Jay Lambiotte  
Analysis and Computation

Samuel E. Massenberg  
Office of Education

Donald J. Baker  
Structural Mechanics

Randy L. Harris  
Flight Management

Thomas J. Horvath  
Space Systems Division

James G. Batterson  
Guidance and Control

Charles J. Camarda  
Structural Mechanics

Howard Puckett  
Management Support

**Name and Institution**

Garfield B. Simms  
Hampton University

Ballou S. Skinner (R)  
University of South Carolina

Alphonso C. Smith  
Hampton University

Dave Sree (R)  
Tuskegee University

Motez Tapia  
University of Miami

David W. Thompson  
College of William and Mary

Robert L. Tureman  
Paul D. Camp Community College

Resit Unal  
Old Dominion University

Cornelis P. Van Dam  
University of California

Chivey Wu  
California State University-LA

**NASA Associate and Division**

Robert S. Rogowski  
Instrument Research

Roger A. Breckenridge  
Space Station Freedom Office

Robert S. Rogowski  
Instrument Research

Scott O. Kjelgaard  
Fluid Mechanics

Vernon W. Wessell  
Facilities Engineering

Anne K. St. Clair  
Materials

James F. Meyers  
Human Resources Management

Douglas O. Stanley  
Space Systems

Cynthia C. Lee  
Flight Applications

L. Elwood Putnam  
Applied Aerodynamics

**APPENDIX II**  
**LECTURE SERIES**  
**PRESENTATIONS BY RESEARCH FELLOWS**

1993

NASA/ASEE Summer Faculty Fellowship Program  
and Langley Aerospace Research Summer Scholars Program

TECHNICAL LECTURE SERIES

Location: Activities Center Auditorium, Bldg. 1222

Time: 10:00 a.m. - 10:45 a.m. - Lecture

10:45 a.m. - 11:00 a.m. - Questions and Answer

<b><u>DATE</u></b>	<b><u>TOPIC</u></b>	<b><u>SPEAKER</u></b>
June 14	Dynamics and Control of Coupled Multi-Body Spacecraft	Dr. Raymond C. Montgomery Guidance & Control Division Flight Systems Directorate
June 21	Assembly and Deployment of Space Structures	Dr. Mark S. Lake Structural Mechanics Division Structures Directorate
June 28	Ozone, Climate, and Global Change	Dr. Joel S. Levine Atmospheric Sciences Division Space Directorate
July 12	Instrument Balloon Experiment (IBEX)	Dr. Ira G. Nolt Flight Electronics Division Electronics Directorate
July 19	High-Performance Computing and Communications	Dr. Thomas A. Zang Fluid Mechanics Division Aeronautics Directorate
July 26	The Common Housefly as a Powerplant for the World's Smallest Aircraft	Mr. Don Emmick President Fly-By-Night Airplane Company

5/18/93

**NASA Langley Research Center**

**ASEE Summer Faculty Fellowship Program**

**and**

**Langley Aerospace Research Summer**

**Scholars (LARSS) Program**

**TECHNICAL LECTURE SERIES**

**NEXT LECTURE**

June 28, 1993

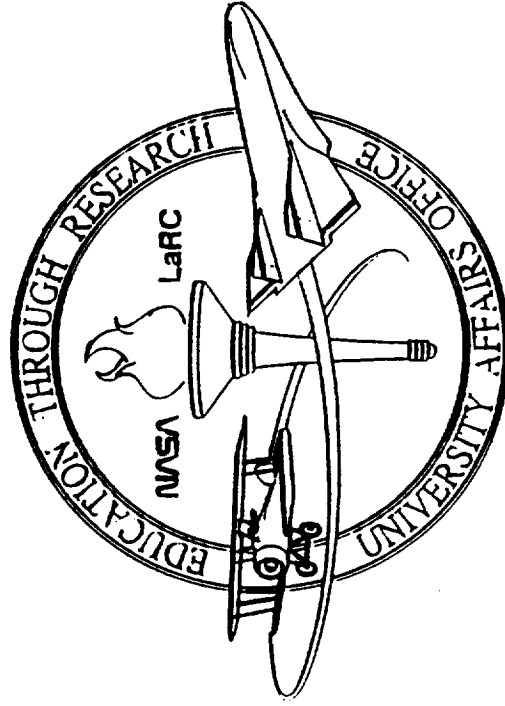
**OZONE, CLIMATE, AND GLOBAL CHANGE**

presented by

Dr. Joel S. Levine

Space Directorate

Atmospheric Sciences Division



**June 21, 1993**



**Assembly and Deployment of Space Structures**  
presented by  
**Mark S. Lake**  
**Structures Directorate**  
**Structural Mechanics Division**

An overview of fifteen years of research in the assembly and deployment of space structures is presented. The overview provides a historical perspective on the evolution of NASA's requirements for in-space assembly and deployment of structures, and an illustration of how these changing needs have provided focus for Langley's basic research program. Requirements for the development and testing of flight-quality structural hardware are explained, and prototype hardware is presented for handling and viewing.

Three in-space construction approaches are discussed: manual assembly by astronauts in extravehicular activity (EVA), automated assembly by robots, and automated deployment. Past test programs are reviewed including EVA construction of the primary truss structure for Space Station Freedom and EVA and robotic construction of large precision segmented reflectors. Finally, current and future research activities are discussed.

**Dr. Mark S. Lake**

- Received a B.S. in Aeronautical and Astronautical Engineering from the University of Illinois, a M.S. in Mechanical Engineering from Old Dominion University, and a Ph.D. in Aerospace Engineering from North Carolina State University.
- Joined NASA LaRC in 1981 on the Cooperative Education Program, began full-time employment in 1984.
- Research activities include the design, analysis, and testing of advanced concepts for spacecraft and launch vehicle structures with emphasis on lightweight truss structures.
- Has accumulated over 40 hours of simulated EVA time in the Space Shuttle Extravehicular Mobility Unit (EMU-space suit) during underwater structural assembly testing.

**NASA Langley Research Center  
American Society for Engineering Education Summer Faculty Fellowship Program  
Final Presentation Agenda**

**H.J.E. Reid Conference Center, Building 1222  
Wednesday, August 11, 1993, and Thursday, August 12, 1993**

<b><u>Time</u></b>	<b><u>Name/Division/University</u></b>	<b><u>Topic</u></b>
<b>Wednesday, August 11, 1993</b>		
9:00	Welcome	Assistant University Affairs Officer
9:05	Dr. Thomas Gally/AAD Texas A&M University	"Investigation of Aerodynamic Design Issues with Regions of Separated Flow"
9:30	Dr. Alphonso Smith/IRD Hampton University	"Fiber Optic Sensors for Corrosion Detection"
10:00	Dr. Jen-Kuang Huang/GCD Old Dominion University	"System Identification of the Large-Angle Magnetic Suspension Test Facility (LAMSTF)"
10:30	Dr. Catherine Brinson/MD Northwestern University	"Effects of Physical Aging on Long-Term Behavior of Composites"
11:00	Dr. Chivey Wu/AAD California State University-LA	"Navier-Stokes Computations for A 65° Delta Wing with a Sharp Leading Edge"
11:30	Dr. Resit Unal/SSD Old Dominion University	"Multidisciplinary Design Optimization Using Saturated Designs"
12:00	Adjourn	
<b>Thursday, August 12, 1993</b>		
9:00	Welcome	Assistant University Affairs Officer
9:05	Dr. Rex Kincaid/SDyD College of William & Mary	"The Molecular Matching Problem"
9:30	Dr. James Green/ACD Maravian College	"Image Pattern Recognition Approaches in Support of Data Analysis"
10:00	Mr. Robert Tureman/HRMD Paul D. Camp Community College	"Human Resources' ADP Analysis Project"
10:30	Dr. Drew Landman/FldMD Old Dominion University	"Experimental Apparatus for Optimizations of Flap Position for a Three-Element Airfoil Model"
11:00	Dr. Robert Hodson/FED Christopher Newport University	"Application Specific Integrated Circuits"
11:30	Dr. James Rankin/FltMD St. Cloud State University	"GPS and Differential GPS: An Error Model for Sensor Simulation"
12:00	Adjourn for Lunch	
1:00	<b>Unsolicited Proposal Seminar</b>	

**APPENDIX III**  
**GROUP PICTURE OF RESEARCH FELLOWS**

ORIGINAL PAGE  
BLACK AND WHITE PHOTOGRAPH



Those pictured in group photograph from left to right are:

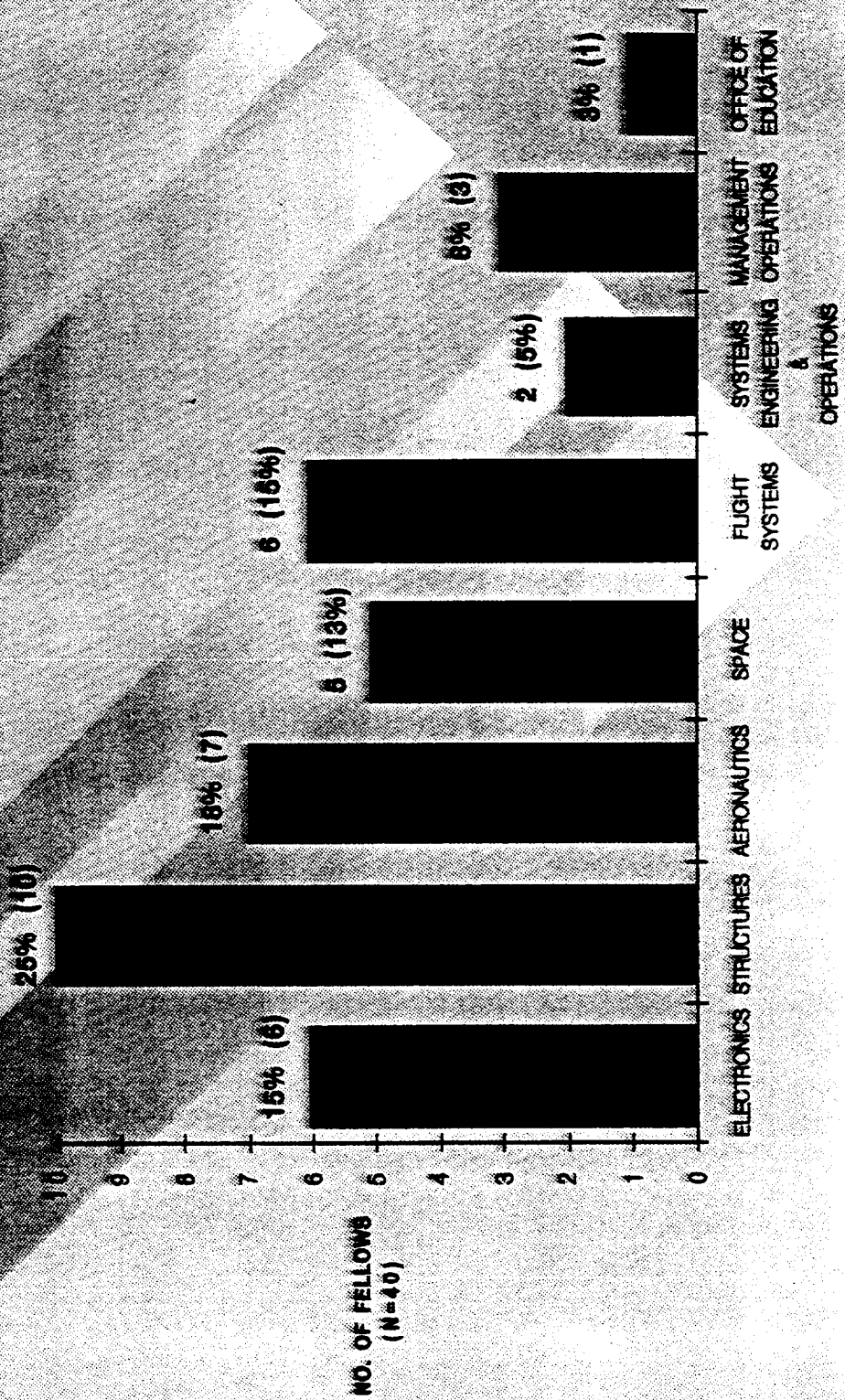
Masoud Rais-Rohani, Jeffrey Bellinger, Chun-Shin Lin, Sherilee Beam, Steven Gray, Denise Siegfeldt, Chivey Wu, Sandra Proctor, Elaine Scott, Frederick Freeman, Erdogan Madenci, James Green, Jan Bialasiewicz, David Thompson, Catherine Brinson, Roy Gratz, Milton Ferguson, Hira Narang, Richard Kiefer, Rex Kincaid, Ballou Skinner, Robert Tureman, Moiez Tapia, Drew Landman, Thomas Gally, John Cimbala, Anthony Ghorieshi, C. Subba Reddy, Ramesh Krishnamurthy, Dave Sree, James Rankin

Not Pictured:

James Aberle, Ken Chang, Robert Hodson, Jen-Kuang Huang, Bary Malik, George Rublein, Garfield Simms, Alphonso Smith, Resit Unal, Cornelis Van Dam

**APPENDIX IV**  
**DISTRIBUTION OF FELLOWS BY DIRECTORATE**

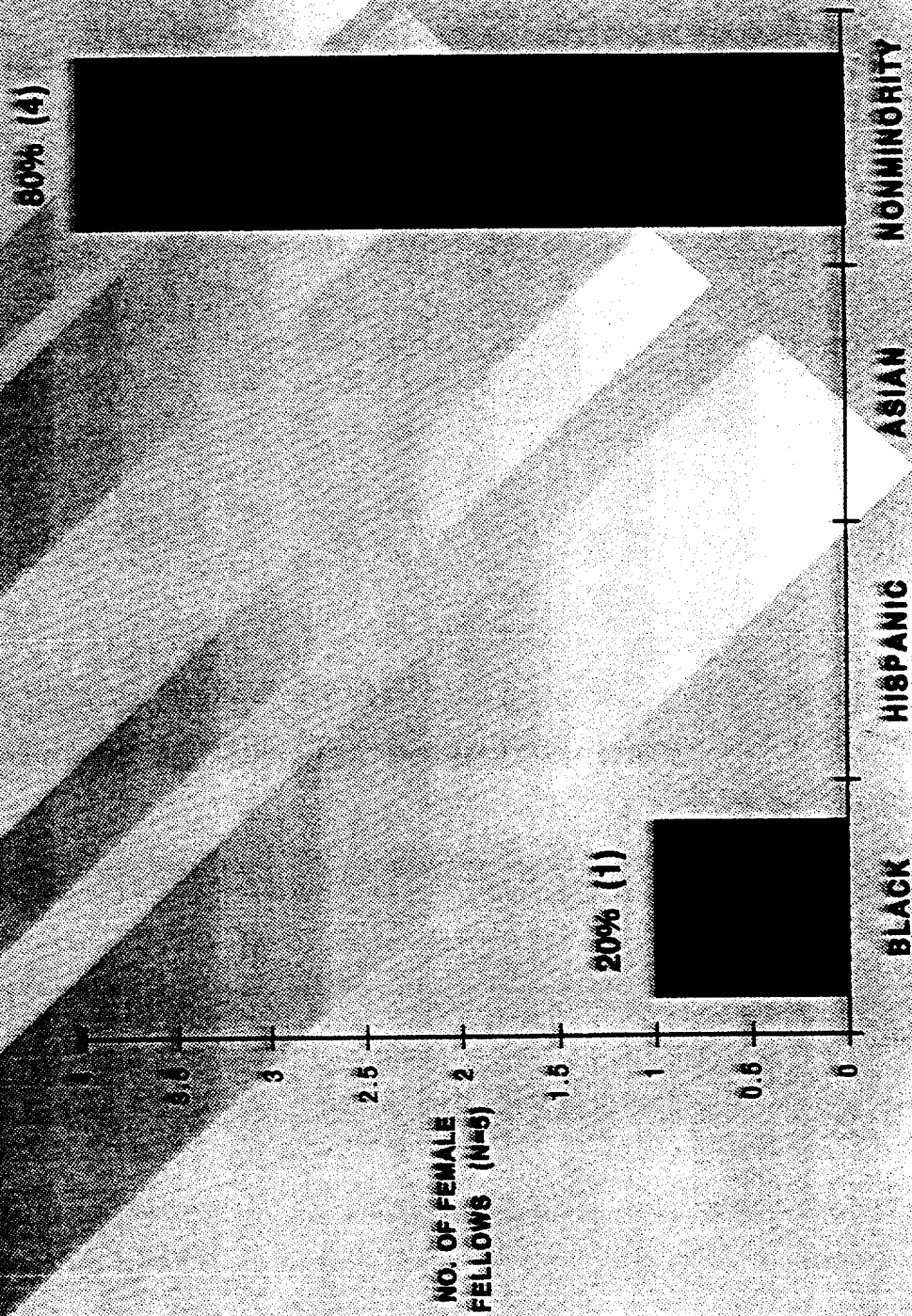
# DISTRIBUTION OF 1997 ASEE (SRSD) FELLOWS BY DIRECTORATE



**APPENDIX V**  
**DISTRIBUTION OF FELLOWS BY ETHNICITY/FEMALE**

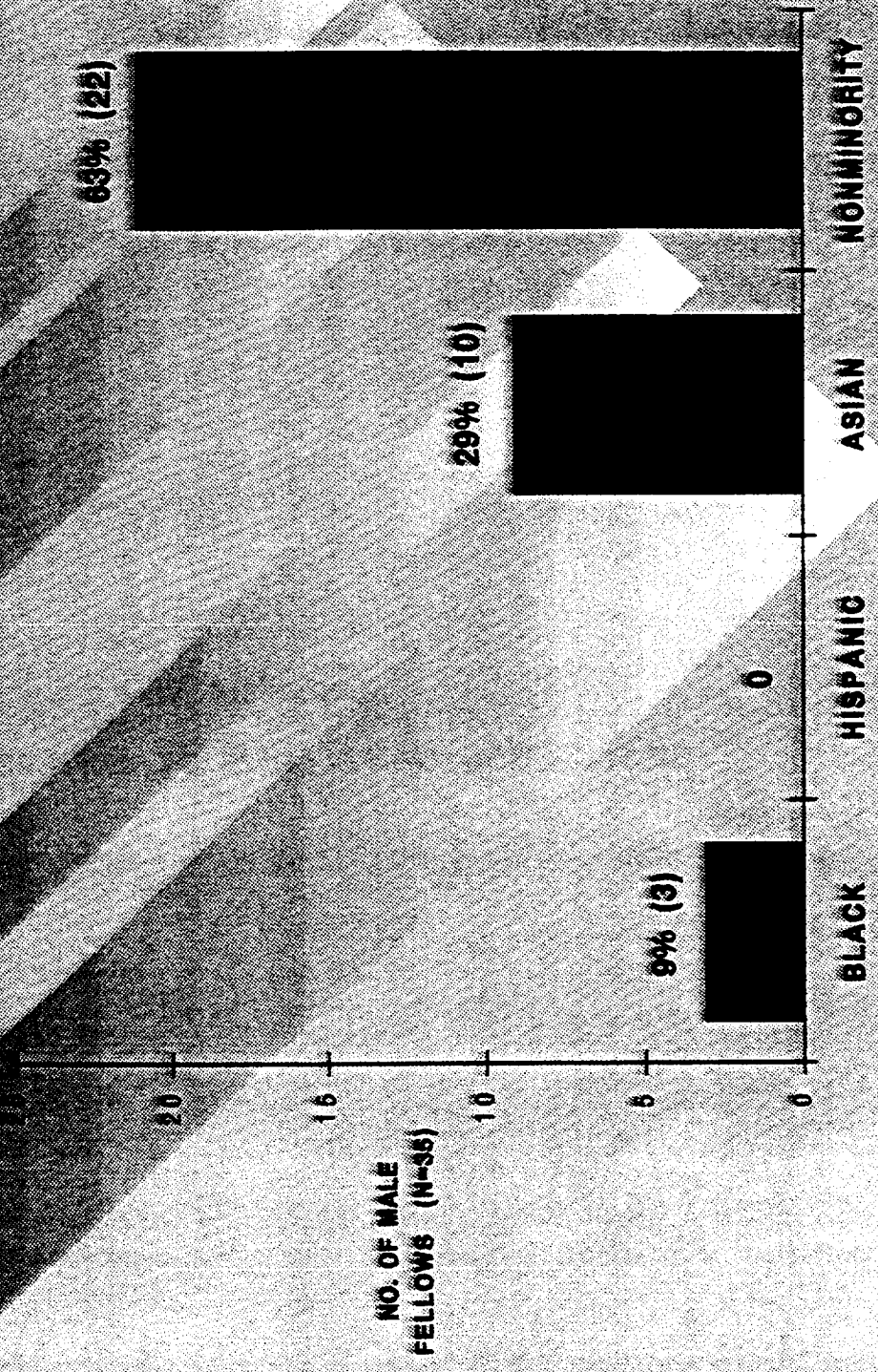


**DISTRIBUTION OF 1993 ASEE  
(NSFP) FEMALE FELLOWS  
BY ETHNICITY**



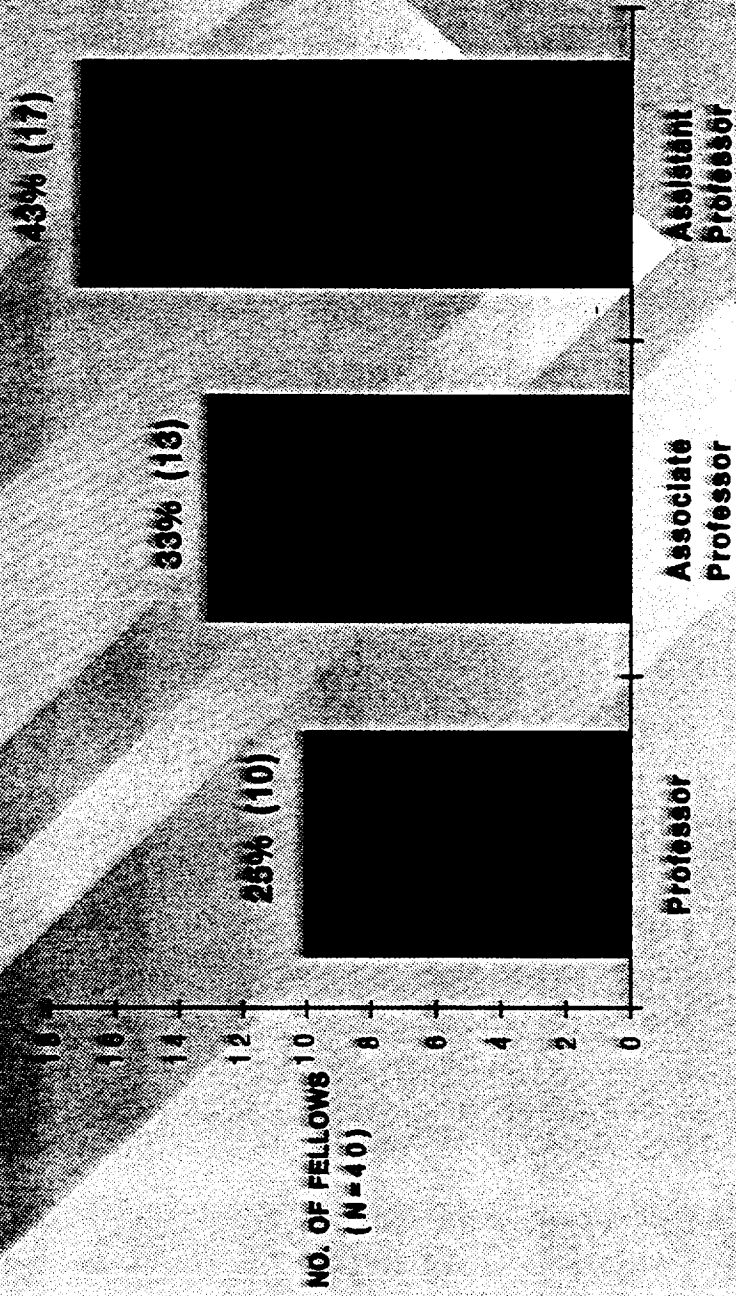
**APPENDIX VI**  
**DISTRIBUTION OF FELLOWS BY ETHNICITY/MALE**

# CONTRIBUTION OF 2003 ASEE (SMP) MALE FELLOWS BY ETHNICITY



**APPENDIX VII**  
**DISTRIBUTION OF FELLOWS BY UNIVERSITY RANK**

# DISTRIBUTION OF 1993 FELLOWS BY UNIVERSITY RANK



**APPENDIX VIII**  
**DISTRIBUTION OF FELLOWS BY UNIVERSITY**

**1993 ASEE SUMMER FACULTY FELLOWSHIP PROGRAM  
INSTITUTION PARTICIPATION**

<u>UNIVERSITY/COLLEGE</u>	<u>NO. OF FELLOWS</u>
Arizona State University	1
California State University-LA	1
Christopher Newport University	2
College of William and Mary	3
Drexel University	1
*Hampton University	3
Maravian College	1
Mary Washington College	1
Mississippi State University	1
*Norfolk State University	2
Northwestern University	1
Old Dominion University	5
Paul D. Camp Community College	1
Pennsylvania State University	1
Purdue University	1
S. Illinois University-Carbondale	1
St. Cloud State University	1
Texas A&M University	1
Troy State University-Naval Base	1
*Tuskegee University	2
University of Arizona	1
University of California	1
University of Colorado-Denver	1
University of Miami	1
University of Missouri-Columbia	1
University of South Carolina	1
Virginia Polytechnic Institute and State University	1
*Virginia State University	1
Wilkes University	<u>1</u>
<b>Total Number of Fellows</b>	<b>40</b>
<b>Total Number of Institutions Represented</b>	<b>29</b>
*Indicates a Historically Black College or University (HBCU).	

**APPENDIX IX**  
**SAMPLE QUESTIONNAIRES**



**American Society for Engineering Education**  
**NASA/ASEE Summer Faculty Fellowship Program**  
**Evaluation Questionnaire**

**(Faculty Fellows are asked to respond to the following questions.)**

Name: \_\_\_\_\_

Birthdate: \_\_\_\_\_

Social Security Number: \_\_\_\_\_

Permanent Mailing Address: \_\_\_\_\_

\_\_\_\_\_

\_\_\_\_\_

\_\_\_\_\_

Home Institution: \_\_\_\_\_

NASA Center and (Laboratory) Division: \_\_\_\_\_

Name of Research Associate: \_\_\_\_\_

Brief Descriptive Title of Research Topic: \_\_\_\_\_

\_\_\_\_\_

**American Society for Engineering Education**  
**NASA/ASEE Summer Faculty Fellowship Program**  
**Evaluation Questionnaire**

**(Faculty Fellows are asked to respond to the following questions and  
return to Debbie Young at Mail Stop 400 no later than Friday,  
August 13, 1993.)**

Name: \_\_\_\_\_

Birthdate: \_\_\_\_\_

Social Security Number: \_\_\_\_\_

Permanent Mailing Address: \_\_\_\_\_

\_\_\_\_\_  
\_\_\_\_\_  
\_\_\_\_\_

Home Institution: \_\_\_\_\_

NASA Center and (Laboratory) Division: \_\_\_\_\_

Name of Research Associate: \_\_\_\_\_

Brief Descriptive Title of Research Topic: \_\_\_\_\_

\_\_\_\_\_

**A. Program Objectives**

1. Are you thoroughly familiar with the research objectives of the research (laboratory) division you worked with this summer?

Very much so \_\_\_\_\_  
Somewhat \_\_\_\_\_  
Minimally \_\_\_\_\_

2. Do you feel that you were engaged in research of importance to your Center and to NASA?

Very much so \_\_\_\_\_  
Somewhat \_\_\_\_\_  
Minimally \_\_\_\_\_

3. Is it probable that you will have a continuing research relationship with the research (laboratory) division that you worked with this summer?

Very much so \_\_\_\_\_  
Somewhat \_\_\_\_\_  
Minimally \_\_\_\_\_

4. My research colleague and I have discussed follow-up work including preparation of a proposal to support future studies at my home institution, or at a NASA laboratory.

Yes \_\_\_\_\_ No \_\_\_\_\_

5. What is the level of your personal interest in maintaining a continuing research relationship with the research (laboratory) division that you worked with this summer?

Very much so \_\_\_\_\_  
Somewhat \_\_\_\_\_  
Minimally \_\_\_\_\_

**B. Personal Professional Development**

1. To what extent do you think your research interests and capabilities have been affected by this summer's experience? You may check more than one.

- Reinvigorated \_\_\_\_\_
- Redirected \_\_\_\_\_
- Advanced \_\_\_\_\_
- Just maintained \_\_\_\_\_
- Unaffected \_\_\_\_\_

2. How strongly would you recommend this program to your faculty colleagues as a favorable means of advancing their personal professional development as researchers and teachers?

- With enthusiasm \_\_\_\_\_
- Positively \_\_\_\_\_
- Without enthusiasm \_\_\_\_\_
- Not at all \_\_\_\_\_

3. How will this experience affect your teaching in ways that will be valuable to your students? You may check more than one.

- By integrating new information into courses \_\_\_\_\_
- By starting new courses \_\_\_\_\_
- By sharing your research experience \_\_\_\_\_
- By revealing opportunities for future employment in government agencies \_\_\_\_\_
- By deepening your own grasp and enthusiasm \_\_\_\_\_
- Will affect my teaching little, if at all \_\_\_\_\_

4. Do you have reason to believe that those in your institution who make decisions on promotion and tenure will give you credit for selection and participation in this highly competitive national program?

Yes \_\_\_\_\_ No \_\_\_\_\_

**C. Administration**

1. How did you learn about the Program? Check appropriate response.

- Received announcement in the mail \_\_\_\_\_
- Read about in a professional publication \_\_\_\_\_
- Heard about it from a colleague \_\_\_\_\_
- Other (Explain below) \_\_\_\_\_
- \_\_\_\_\_
- \_\_\_\_\_
- \_\_\_\_\_

2. Did you also apply to other summer faculty programs?

Yes \_\_\_\_\_ No \_\_\_\_\_

- \_\_\_\_\_ DOE
- \_\_\_\_\_ Another NASA Center
- \_\_\_\_\_ Air Force
- \_\_\_\_\_ Army
- \_\_\_\_\_ Navy

3. Did you receive an additional offer of appointment from one or more of the above? If so, please indicate from which.

Yes \_\_\_\_\_ No \_\_\_\_\_

\_\_\_\_\_

4. Did you develop new areas of research interests as a result of your interaction with your Center and laboratory colleagues?

- Many \_\_\_\_\_
- A few \_\_\_\_\_
- None \_\_\_\_\_

5. Would the amount of the stipend (\$1,000 per week) be a factor in your returning as an ASEE Fellow next summer?

Yes \_\_\_\_\_ No \_\_\_\_\_

If not, why? \_\_\_\_\_

\_\_\_\_\_

6. Did you receive any informal or formal instructions about submission of research proposals to continue your research at your home institution?

Yes \_\_\_\_\_ No \_\_\_\_\_

7. Was the housing and programmatic information supplied prior to the start of this summer's program adequate for your needs?

Yes \_\_\_\_\_ No \_\_\_\_\_

8. Was the contact with your research colleague prior to the start of the program adequate?

Yes \_\_\_\_\_ No \_\_\_\_\_

9. How do you rate the seminar program?

Excellent \_\_\_\_\_  
 Very good \_\_\_\_\_  
 Good \_\_\_\_\_  
 Fair \_\_\_\_\_  
 Poor \_\_\_\_\_

10. In terms of the activities that were related to your research assignment, how would you describe them on the following scale?

Check one per activity		Time Was			
Activity	Adequate	Too Brief	Excessive	Ideal	
Research					
Lectures					
Tours					
Social/Recreational					
Meetings					

11. What is your overall evaluation of the program?

Excellent \_\_\_\_\_  
 Very good \_\_\_\_\_  
 Good \_\_\_\_\_  
 Fair \_\_\_\_\_  
 Poor \_\_\_\_\_

12. If you can, please identify one or two significant steps to improve the program.

---

---

---

---

13. For second-year Fellows only. Please use this space for suggestions on improving the second year.

---

---

---

---

**D. Stipend**

1. To assist us in planning for appropriate stipends in the future, would you indicate your salary at your home institution?

\$ \_\_\_\_\_ per Academic year \_\_\_\_\_ or Full year \_\_\_\_\_.  
(Please check one.)

2. Is the amount of the stipend the primary motivator to your participation in the ASEE Summer Faculty Fellowship Program?

Yes \_\_\_\_\_ No \_\_\_\_\_ In Part \_\_\_\_\_

3. What, in your opinion, is an adequate stipend for the ten-week program during the summer of 1994?

\$ \_\_\_\_\_

**E. American Society for Engineering Education (ASEE) Membership Information**

1. Are you currently a member of the American Society for Engineering Education?

Yes \_\_\_\_\_ No \_\_\_\_\_

2. Would you like to receive information pertaining to membership in the ASEE?

Yes \_\_\_\_\_ No \_\_\_\_\_





**1993 NASA/ASEE SUMMER FACULTY FELLOWSHIP RESEARCH PROGRAM**

**QUESTIONNAIRE FOR RESEARCH ASSOCIATES**

Please complete and return to Surendra N. Tiwari by Friday, Sept. 10, 1993, MS 400. Thank you.

Research Fellow's Name \_\_\_\_\_

Research Associate's Name \_\_\_\_\_

1. Was your Fellow adequately prepared for his/her research assignment?

Yes          No          (Circle One)

Comments: \_\_\_\_\_  
 \_\_\_\_\_  
 \_\_\_\_\_  
 \_\_\_\_\_

2. In the rating scale below, please give your opinion on how your Fellow approached his/her research assignment.

	<b>Outstanding</b>	<b>Above Avg.</b>	<b>Avg.</b>	<b>Fair to Good</b>	<b>Poor</b>
a. Knowledge of subject					
b. Diligence					
c. Interest in Assignment					
d. Enthusiasm					

3. Did your Fellow accomplish the research goals established by you for the ten week period?

Yes          No          (Circle One)

Comments: \_\_\_\_\_  
\_\_\_\_\_  
\_\_\_\_\_  
\_\_\_\_\_

4. Was there any change in assignment from that expected by your Fellow?

Yes          No          (Circle One)

If yes, please give reason(s) for change: \_\_\_\_\_  
\_\_\_\_\_  
\_\_\_\_\_  
\_\_\_\_\_

5. Would you be interested in serving as a Research Associate again?

Yes          No          (Circle One)

Comments: \_\_\_\_\_  
\_\_\_\_\_  
\_\_\_\_\_  
\_\_\_\_\_

6. How did your Fellow compare overall with other faculty researchers you have worked with? (Please check one)

Equal to the Best       Very Good       Above Average       Average       Below Average

7. Was there discussion of any type of follow on research for the future, specifically regarding submission of a proposal?

Yes      No      (Circle One)

Comments: \_\_\_\_\_  
\_\_\_\_\_  
\_\_\_\_\_  
\_\_\_\_\_

8. Would you recommend your Fellow for employment in your organization?

Yes      No      (Circle One)

Comments: \_\_\_\_\_  
\_\_\_\_\_  
\_\_\_\_\_  
\_\_\_\_\_

9. Please give recommendations for improving the program.

Comments: \_\_\_\_\_  
\_\_\_\_\_  
\_\_\_\_\_  
\_\_\_\_\_

**APPENDIX X**  
**ABSTRACTS - RESEARCH FELLOWS**

# HYBRID TECHNIQUES FOR COMPLEX AEROSPACE ELECTROMAGNETICS PROBLEMS

**Jim Aberle, Ph.D.**  
**Assistant Professor**  
**Department of Electrical Engineering**  
**Arizona State University**  
**Tempe, AZ 85287-5706**

## **Abstract**

Important aerospace electromagnetics problems include the evaluation of antenna performance on aircraft, and the prediction and control of the aircraft's electromagnetic signature. Due to the ever increasing complexity and expense of aircraft design, aerospace engineers have become increasingly dependent on computer solutions. Traditionally, computational electromagnetics (CEM) has relied primarily on four disparate techniques: the method of moments (MoM), the finite-difference time-domain (FDTD) technique, the finite element method (FEM), and high frequency asymptotic techniques (HFAT) such as ray tracing. Each of these techniques has distinct advantages and disadvantages, and no single technique is capable of accurately solving all problems of interest on computers that are available now or will be available in the foreseeable future. As a result, new approaches that overcome the deficiencies of traditional techniques are beginning to attract a great deal of interest in the CEM community. Among these new approaches are hybrid methods which combine two or more of these techniques into a coherent model. During the ASEE Summer Faculty Fellowship Program a hybrid FEM/MoM computer code was developed and applied to a geometry containing features found on many modern aircraft.

## **INTRODUCTION**

The Antenna and Microwave Research Branch (AMRB) at LaRC has identified prediction of the radiation characteristics of antennas on composite aircraft as a research topic of major importance to the aerospace industry over the next decade. Evaluation of these radiation characteristics requires the development of accurate and efficient numerical models. Unfortunately, numerical models based solely on one of the four traditional CEM methods are likely to perform poorly on this task. The problems of interest exhibit a combination of features which include radiation, geometrical complexity, complex materials and large electrical size. While the four traditional CEM techniques (MoM, FDTD, FEM and HFAT) are each well-suited to specific features of these problems, none of these techniques is well-suited to handle all of these features. An overview of the characteristics of the four traditional CEM techniques is given in Table I. Most research to date has focused on using MoM to treat such problems. It has been found that excessive computation times and large matrix condition numbers become troublesome above about 200 MHz. In addition, MoM cannot handle the geometric and material complexity often found in modern aircraft. The other three traditional techniques suffer from their own limitations. However, by combining two or more of these traditional techniques in a coherent hybrid model, wherein each component technique is applied to the part of the problem to which it is best suited, we expect to overcome these limitations. The result would be the development of accurate and efficient simulation tools for these problems.

Previous work on hybrid techniques has concentrated on the combination of MoM and HFAT, and the combination of FEM and MoM. The MoM/HFAT hybrids have enabled workers to model radiating structures on electrically large bodies. However, these

methods are limited by the geometrical and material complexity of the structure. The FEM/MoM hybrids have enabled workers to model geometrically and materially complex radiating structures. The limitation of these hybrids is the electrical size of the object, which generally must be less than several tens of wavelengths. In present FEM/MoM hybrids, MoM is used only as a means of treating the radiation property of EM fields in lieu of an absorbing boundary condition (ABC). Research conducted this summer at LaRC has focused on extending FEM/MoM hybrids to problems that feature both complex structures that are well-suited for FEM, and simpler radiating structures that are well suited for MoM. The long term goal of this research is to develop a hybrid FEM/MoM/HFAT technique that can accurately and efficiently solve the problem of complex radiating structures on electrically large structures comprising composite materials.

## RESEARCH ACCOMPLISHMENTS

A computer code designed specifically to evaluate the scattering width of the geometry shown in Figure 1 has been implemented. The structure illustrated in Figure 1 includes the following salient features: a geometrically and materially complex cavity region that is well suited for solution via FEM, and simple slot and strip radiators that are well suited for solution via MoM. Such features are common on aircraft. For example, we may be interested in the effect of a nearby jet engine cavity on the radiation pattern of a blade antenna. The insights gained in developing the code for this relatively simple problem will assist researchers in developing similar codes for more complex structures. In addition, many of the specific subroutines developed for this problem, particularly the custom iterative solver, can be directly incorporated into future hybrid codes for more complex problems.

The steps required in the development of the hybrid code for the geometry shown in Figure 1 were development of a MoM solution for the slot and strip radiators, development of an FEM solution for the cavity region, derivation of the system of equations governing the hybrid solution for the geometry, development of a custom iterative solver for this system of equations, and computer implementation of the hybrid solution.

The FEM/MoM hybrid technique requires solution of a linear system comprising a partially sparse, partially dense matrix. The sparse part of the matrix arises from the FEM part of the solution and is, in general, much larger than the dense part of the matrix which results from the MoM part of the solution. Sparse linear systems are well-suited for solution via iterative methods such as the biconjugate gradient algorithm. Significant savings in computation time as well as computer memory can be realized by storing the sparse matrix in profile or banded form and performing operations only on the non-zero elements of the matrix. Unfortunately, such time and memory reduction schemes cannot be used when the matrix is partially dense. For this reason, a custom biconjugate gradient solver has been developed. Use of this custom solver resulted in computation time savings of 100 times or more over dense matrix techniques.

## FUTURE RESEARCH

Future research will concentrate on hybridizing the existing FEM/MoM hybrid code with an appropriate HFAT. Incorporation of HFAT into the hybrid code will allow treatment of complex radiating structures on electrically large composite aircraft. Such a hybrid FEM/MoM/HFAT code would be a valuable tool for the aerospace industry.

FEATURE	TECHNIQUE			
	MoM	FDTD	FEM	HFAT
Radiation	easy	need ABC	need ABC	easy
Geometrical complexity	hard	easy	easy	impossible
Material complexity	hard	easy	easy	hard
Large electrical size	hard	hard	hard	easy
Non-linearities	impossible	easy	impossible	impossible

Table 1. Overview of CEM methods.

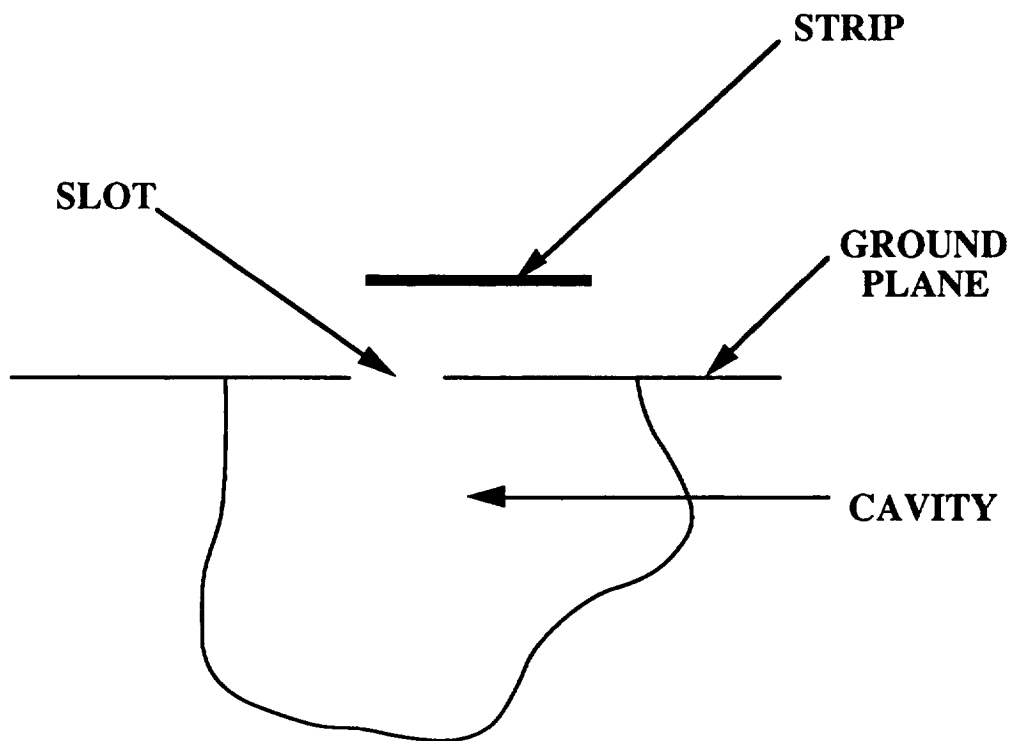


Figure 1. Geometry of strip above a cavity-backed slot.

**RIAD VISUAL IMAGING BRANCH ASSESSMENT**

by

**Professor Sherilee F. Beam  
Mass Media Arts Department  
Hampton University  
Hampton, VA 23668**

**INTRODUCTION**

Every year the demand to visualize research efforts increases. The visualization provides the means to effectively analyze data and present the results. The technology support for visualization is constantly changing, improving and being made available to users everywhere. As such, many researchers are entering into the practice of doing their own visualization in house--sometimes successfully, sometimes not.

In an effort to keep pace with the visualization needs of researchers, the Visual Imaging Branch of the Research, Information and Applications Division at NASA Langley Research Center has conducted an investigation into the current status of imaging technology and imaging production throughout the various research branches at the center. This investigation will allow the Branch to evaluate its current resources and personnel in an effort to identify future directions for meeting the needs of the researchers at the Center. The investigation team, which consisted of the ASEE fellow, the Head of the Video Section and the Head of the Photo Section developed an interview format that could be accomplished during a short interview period with researchers, and yet still provide adequate statistics about items such as in-house equipment and usage. The team met personally with over 120 researchers from 20 different branches at the Center. On the average, each of the meetings lasted approximately an hour and a half and were conducted in an open-dialogue format.

**SYNOPSIS**

It's evident that researchers prefer to have their own imaging technology on site for a number of reasons. If the equipment is in-house, they are able to control its availability. They also have direct input to the type of equipment purchased. Younger researchers tend to have a different attitude about the imaging techniques and process than their older counterparts. Because the equipment has become easier to obtain and use, they often feel they can do what they need themselves.

There is a difference between imaging techniques for technical purposes and those for presentation purposes: one is analysis and study; the other is most often for external information dissemination. On the whole, the researchers acknowledge this difference. Generally, they use their imaging technology for analyzing data or for technical presentations, which are most often internal for their peers or management. As such, the attention to technical content is highly detailed and complete for their audience. However, since it is not a priority, the aesthetics of the presentation may be lacking. With the increasing awareness of video technical reports, more will be produced. Researchers wonder how they will be classified. As peer reviewers themselves publish in this format, the acceptability will broaden. Most researchers recognize the need for producing general audience projects for information dissemination and/or advocacy purposes, especially with NASA's current emphasis on technology transfer. As a matter of fact, almost all of the groups expressed an interest in pursuing a production of this nature, using both still photography and video. Since they are engaged in research, they want the process to be smooth and not take up a lot of their time; otherwise, they will avoid assistance and attempt to do a project in-house. Archival methods vary and are haphazard in most cases. Although all researchers agree that archiving results, photos, productions, etc. is important, their methods vary. The primary request in this area is to be able to electronically archive and access negatives and photographs.

Repeatedly, researchers have commented on the tremendous amount of visual imaging technology and professional personnel throughout the field, but they are concerned with the "shot gun" effect that still exists. It was suggested that a central location could act as a clearing house to



discuss requests. Until they see a photo-layout or video production done by someone else, many are not aware of the level of quality that exists here.

At some point during the course of research, all groups have had support from the Photo Section, and half of them had support from the Video Section. For the most part, anyone who had used Branch services within the last several years gave high marks for response time and quality. Although a researcher may not have had a positive experience in the past when using services in the Photo or Video section, seldom did anyone use an outside service. Usually, they found a way to do it themselves or did without the service. In almost every case, the number one request related to future support from the Visual Imaging Branch is for a means to transfer computer files electronically to facilities, where the files can be processed (if necessary), enhanced, used for production, or turned into a hard copy format, and then returned to the researcher via the same method of transfer. They are not interested in searching for the particular service they need, nor physically going to that location. Also high on the wish list is someone to help them when they are interested in using visual imaging services elsewhere at the Center.

### **RECOMMENDATIONS**

Since there is such a large number of researchers using their own equipment for still, video, or graphics production in some form, input from the Branch about acquisition is prudent. As they are concerned with maintaining the quality and integrity of the image, they need to be aware of the best possible equipment their budgets will allow. Having the Branch involved as a consultant will save them the trouble of obtaining equipment information or meeting with the salespeople. Workshop sessions in all areas of imaging, with basic "how to" tips, could improve what they are currently doing. Many of researchers eventually want to do full-blown productions, which may require incorporating something they have generated in-house. Getting involved at the front end will provide more positive results for both the researcher and the Branch.

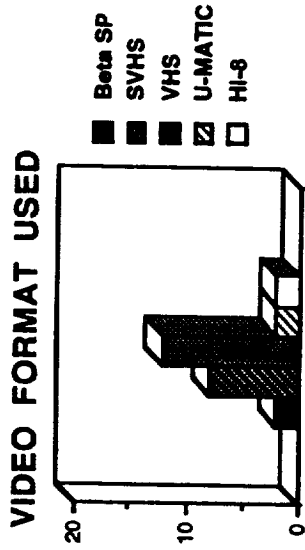
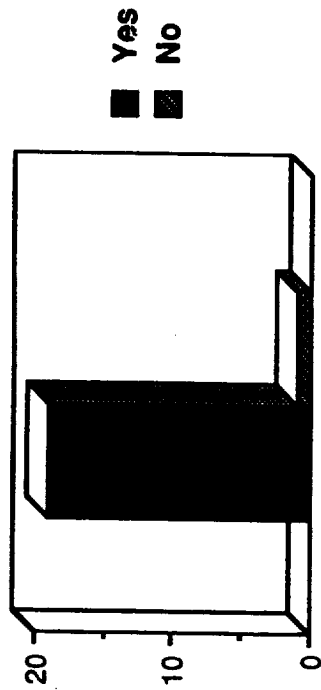
Better coordination and consolidation among all of the imaging facilities and personnel throughout the Center is required. At this time, it would be impossible to have all the facilities or personnel in one location; however, communication among these facilities and the people who operate them is essential. Having a focal point of contact with information on all available facilities and personnel is necessary for the researcher who wishes to initiate a project. Since convenience for the researcher is a high priority, streamlining the process will make it more attractive to use. This point of contact should be able to coordinate efforts of facilities within the Directorates of Management Operations (RIAD), Electronics (ACD) and Systems Engineering and Operations (FENG) as they are needed for the researcher's project. Each of these areas provides unique services to the researcher and can be more tightly integrated to facilitate their use. The current Video Users Group is outdated and ineffective, and a new group, which specifically represents all active video and electronic imaging support areas throughout the Center should be organized. This group would need to meet regularly and establish lines of communication. Each support area (RIAD, ACD, FENG) should understand the functions of the other areas and how they mesh together, and from that, develop the focal point of contact for researchers who need visual imaging support.

With the heavy demand to transfer files for image analysis and enhancement, CD-Rom access and production will be essential in the future. Exploring the option of using a fiber optics network is a consideration.

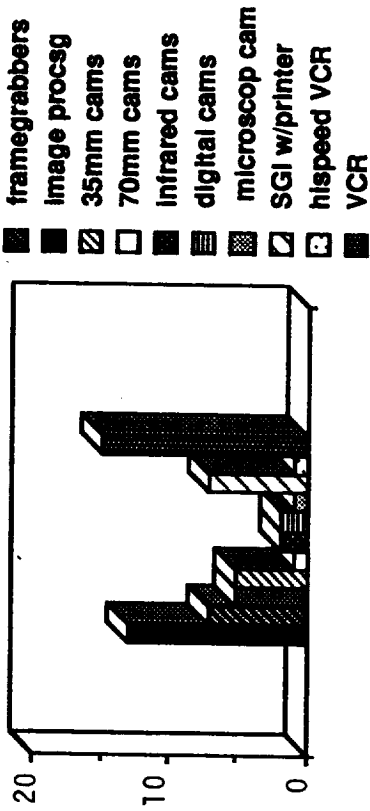
The Division should consider another survey to assess the need for visualization in a research report, from the point of view of the receiver. There are individuals in the research community who believe the visual imaging aspects of a project report are unnecessary. However, the receivers, whether they are technical or lay audiences, would request and, therefore, justify the need for the visual imaging.

Imaging technology and visualization at Langley Research Center is going to continue to grow, because the demand for it will continue to grow. At present, it is imperative to unite the state-of-the-art resources and highly qualified personnel. Decisions regarding equipment and facilities should be influenced by the customers--the research community--and their changing needs.

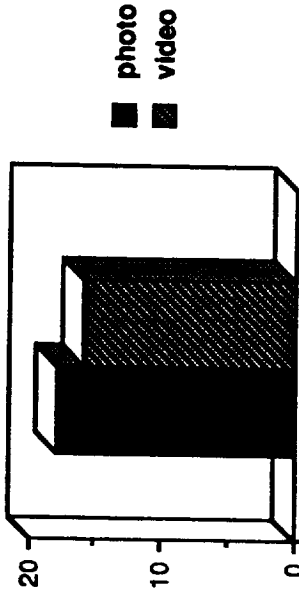
### IMAGING CAPABILITY IN-HOUSE



### EQUIPMENT IN-HOUSE



### REQUESTS FOR FUTURE SERVICES



## ON IDENTIFIED PREDICTIVE CONTROL

by

Jan T. Bialasiewicz  
Associate Professor

University of Colorado at Denver  
Department of Electrical Engineering  
Denver, Colorado 80217-3364

### 1. INTRODUCTION

Self-tuning control algorithms are potential successors to manually tuned PID controllers traditionally used in process control applications. A very attractive design method for self-tuning controllers, which has been developed over recent years, is the long-range predictive control (LRPC). The success of LRPC is due to its effectiveness with plants of unknown order and dead-time which may be simultaneously nonminimum phase and unstable or have multiple lightly damped poles (as in the case of flexible structures or flexible robot arms).

LRPC is a receding horizon strategy and can be, in general terms, summarized as follows. Using assumed long-range (or multi-step) cost function the optimal control law is found in terms of: (1) unknown parameters of the predictor model of the process, (2) current input-output sequence, (3) future reference signal sequence. The common approach is to assume that the input-output process model is known or separately identified and then to find parameters of the predictor model. Once these are known, the optimal control law determines control signal at the current time  $t$  which is applied at the process input and the whole procedure is repeated at the next time instant.

Most of the recent research in this field is apparently centered around the LRPC formulation developed by Clarke *et al.* [1, 2], known as Generalized Predictive Control (GPC). GPC uses ARIMAX/CARIMA model of the process in its input-output formulation. An excellent presentation of predictive controller design in a unified fashion is given by Soeterboek [5] and an interesting application is presented by Soeterboek *et al.* [6].

In this paper, the GPC formulation is used but the process predictor model is derived from the state space formulation of the ARIMAX model and is directly identified over the receding horizon, i.e., using current input-output sequence. The underlying technique in the design of Identified Predictive Control (IPC) algorithm is the identification algorithm of observer/Kalman filter Markov parameters developed by Juang *et al.* [3] at NASA Langley Research Center and successfully applied to identification of flexible structures.

### 2. MODEL OF THE PROCESS

Consider the following locally linearized input-output model of a process under sampled-data control :

$$y(t) = [A(q^{-1})\Delta]^{-1} B(q^{-1})\Delta u(t) + v(t) \quad (1)$$

with

$$v(t) = [A(q^{-1})\Delta]^{-1} \xi(t) \quad (2)$$

where the process input  $u(t) \in R^r$ , the process output  $y(t) \in R^m$ ,  $\xi(t)$  is white noise with variance  $\sigma^2$ , and  $A(q^{-1})$  and  $B(q^{-1})$  are polynomial matrices in unit delay operator  $q^{-1}$ , and  $\Delta = \Delta(q^{-1}) = 1 - q^{-1}$ . The same model can be found by representing the standard state space model with output noise as

$$\begin{aligned} x(t) &= Ax(t) + B\Delta^{-1}(\Delta u(t)) \\ y(t) &= Cx(t) + v(t) \end{aligned} \quad (3)$$

or

$$\begin{aligned} x(t) &= \underline{A}x(t) + \underline{B}\Delta u(t) \\ y(t) &= \underline{C}x(t) + v(t) \end{aligned} \quad \begin{aligned} (4a) \\ (4b) \end{aligned}$$

Thus, the ARIMAX/CARIMA model is represented in state space by a model with output noise and incremental control input and is the starting point in this research.

### 3. PREDICTIVE CONTROL ALGORITHM

In its standard formulation, predictive control algorithm is based on the following minimum variance j-step-ahead predictor  $\hat{y}(t+j)$  of the process output  $y(t)$  given by equations (1) and (2):

$$\begin{aligned} \hat{y}(t+j) &= G_0\Delta u(t+j-1) + G_1\Delta u(t+j-2) + \dots + G_{j-1}\Delta u(t) \\ &\quad + \bar{G}_j(q^{-1})\Delta u(t-1) + F_j(q^{-1})y(t) \\ &\stackrel{df}{=} \tilde{G}_j(q^{-1})\Delta u(t+j-1) + \bar{G}_j(q^{-1})\Delta u(t-1) + F_j(q^{-1})y(t) \end{aligned} \quad (5)$$

where  $\tilde{G}_j(q^{-1})$ ,  $\bar{G}_j(q^{-1})$  and  $F_j(q^{-1})$  are polynomial matrices. In this equation,  $\hat{y}(t+j)$  is expressed as a function of future incremental control inputs, past incremental control inputs and present and past outputs.

The control sequence  $\tilde{u}$  is determined as one minimizing a quadratic cost function given as

$$J(k) = \sum_{j=N_s}^N e^T(t+j)e(t+j) + \lambda \sum_{j=1}^{NU} \Delta u^T(t+j-1)\Delta u(t+j-1) \quad (6)$$

where

- $\lambda$  is the nonnegative weighting factor identical for all inputs for simplicity,
- $N_s$  is the starting horizon of prediction,
- $NU$  is the control horizon identical for all inputs for simplicity,
- $e(t+j)$  is the predicted system error defined by

$$e(k+j) \stackrel{df}{=} w(k+j) - \hat{y}(k+j) \quad (7)$$

with  $\{w(k+j); j=1, 2, \dots\}$  being the future reference vector sequence.

Defining  $\tilde{u}^T \stackrel{df}{=} [\Delta u^T(t) \quad \Delta u^T(t+1) \quad \dots \quad \Delta u^T(t+N-1)]$ , the solution for  $J_{\min}$  giving the optimal control is

$$\tilde{u} = (\underline{G}^T G + \lambda I)^{-1} \underline{G}^T (w - F) \quad (8)$$

where



## EFFECTS OF PHYSICAL AGING ON LONG-TERM BEHAVIOR OF COMPOSITES

by  
Professor L. Catherine Brinson  
Mechanical Engineering Department  
Northwestern University  
Evanston, IL 60202-3111

### Abstract

The HSCT plane, envisioned to have a lifetime of over 60,000 flight hours and to travel at speeds in excess of Mach 2, is the source of intensive study at NASA. In particular, polymer matrix composites are being strongly considered for use in primary and secondary structures due to their high strength to weight ratio and the options of property tailoring. However, an added difficulty in the use of polymer based materials is that their properties change significantly over time (especially at the elevated temperatures that will be experienced during flight) and prediction of properties based on irregular thermal and mechanical loading is extremely difficult.

This study focused on one aspect of long-term polymer composite behavior: physical aging. When a polymer is cooled to below its glass transition temperature, the material is not in thermodynamic equilibrium and the free volume and enthalpy evolve over time to approach their equilibrium values. During this time, the mechanical properties change significantly and this change is termed *physical aging*. This work begins with a review of the concepts of physical aging on a pure polymer system. The effective time theory, which can be used to predict long term behavior based on short term data, is mathematically formalized. The effects of aging to equilibrium are proven and discussed. The theory developed for polymers is then applied to first to a unidirectional composite, then to a general laminate. Comparison to experimental data is excellent. It is shown that the effects of aging on the long-term properties of composites can be counter-intuitive, stressing the importance of the development and use of a predictive theory to analyze structures.

### Physical Aging of Polymers

The traditional means to explore the effects of physical aging on mechanical properties is through a series of sequenced creep and recovery tests. In these tests, the specimen is initially quenched from above the glass transition to a temperature below  $T_g$ . The time the material exists below its glass transition is referred to as the aging time,  $t_e$ . As aging time progresses, a series of short (in comparison to the elapsed aging time) creep tests are run to extract the momentary creep compliance of the material. A creep test is one in which the load is held constant and the strain is measured as a function of time. Aging proceeds on a log-time scale, as can be seen in Figure 1. The momentary curves are all identical in shape, shifted only across the log-time scale from one another with a shift factor,  $a_{t_e}$ . Note that the material gets stiffer (or less compliant) as aging time progresses. If the shift factor is plotted as a function of aging time on a double-log scale, it is found to map a straight line with a slope of  $\mu$  as shown in Figure 2. The shift rate,  $\mu$ , can then be considered to be a material constant.

The momentary material properties can then be shown to vary with aging time according to

$$S(t) = S_0 e^{(t/\tau(t_e))^\beta}$$

$$\tau(t_e) = \tau(t_{ref}) \cdot \left( \frac{t_e}{t_{ref}} \right)^\mu \quad (1)$$

where  $S_0$ , is the initial compliance,  $\beta$  a shape parameter,  $\tau$  the relaxation time,  $t_{ref}$  the reference aging time.

### Effective Time Theory

If the loading time of a material is not short in comparison to the previous aging time, then aging proceeds even as the test progresses. Thus, if the beginning aging time is  $t_e$ , at some time later during the test the aging time is  $t + t_e$ , where  $t$  is the test time. Taking the initial aging time  $t_e$  to be the reference aging time, the shift factor,  $a$ , at any instant in time can be defined based on  $\mu$ . Thus in any time increment  $dt$  at time  $t$ , all relaxation times are  $1/a$  slower and the time increment is  $1/a$  less eventful than if aging time had not been increasing. The "effective" time increment can then be defined

$$d\lambda = a(t)dt, \quad a(t) = \left( \frac{t_e}{t_e + t} \right)^\mu \quad (2)$$

and the total test time can be reduced to the “effective time”,  $\lambda$

$$\lambda = \int_0^t a(\xi) d\xi. \quad (3)$$

Using the effective time in place of real time in Equation (1) results in prediction of long-term material response based only on material parameters determined from short term tests. Figure 3 illustrates the effective time theory prediction of long-term material response. Note that the compliance deviates sharply from the exponential momentary curve as the test time approaches and exceeds the initial aging time. Figure 4 illustrates the role of the shift rate,  $\mu$ , in the long-term response of a material. Note that the larger values of  $\mu$  lead to a stiffer response at longer times. Thus the shift rate can be used as a screening parameter for selection of materials, higher shift rates being preferable for structural applications.

### **Aging to Equilibrium**

If the material is being loaded at temperatures close to its glass transition, the material can age into equilibrium during a relatively short time frame. According to experimental evidence on a polymer by McKenna and preliminary evidence by Gates on a composite, when the equilibrium aging time,  $t_e^*$ , is exceeded the shift rate does not become zero but decreases by an order of magnitude. In general,  $\mu \approx 1$  before  $t_e^*$  and  $\mu \approx 0.1$  after  $t_e^*$ . In this study the basic concepts of aging and effective time were mathematically formalized to handle this case. The specific formulae will be published elsewhere. Figure 5 shows the results of the long-term predictions along with short-term data from McKenna. Note that if the material is loaded with an initial aging time less than  $t_e^*$ , the response initially follows the momentary curve; then begins to deviate (becoming much stiffer than the momentary curve predicts) as the test time approaches initial aging time; then as the test time and initial aging time combined exceed  $t_e^*$ , the material has “aged into equilibrium” and the response follows parallel to the momentary curve once again. Since the material is aging at a much reduced rate after  $t_e^*$ , accumulating time no longer has the effect of causing the material to remain much stiffer than the momentary response. In the long term response of a material aged into equilibrium, the compliance increases in an exponential manner. Further experiments to verify these results are planned on composites. The implication here is that in a structural situation the material should never be permitted to reach temperatures close enough to  $T_g$  such that aging into equilibrium is possible.

### **Aging and Long Term Response of a Lamina**

In an off-axis lamina, the properties in the loading direction can be determined from the properties in the fiber direction,  $S_{ij}$ , through the traditional transformation

$$\{\epsilon\} = [\bar{S}(t)]\{\sigma\}; \bar{S}_{ij}(t) = f(\theta, S_{ij}). \quad (4)$$

The transverse compliance,  $S_{22}$ , and the shear compliance,  $S_{66}$ , are the only terms of the compliance matrix that are matrix dominated and therefore subject to physical aging. Note that each of these compliance terms will have its own set of defining material parameters ( $S_0, \beta, \tau(t_{ref}), \mu$ ). Consequently, due to the complex interaction of all these terms, the long-term compliance of a lamina with a given fiber angle cannot be intuitively predicted.

The long-term response of a lamina can, however, be determined by applying physical aging concepts to update the relaxation time and effective time individually for the shear and transverse compliance, then performing the transformations of equation (4). Note that equation (4) holds only for the case of constant loading. A future extension to this work will be implementation of the theory into a convolution integral form constitutive law for viscoelasticity. To illustrate the complexity of long term lamina response, consider Figure 6, where the long term load-direction compliance is plotted for a variety of fiber angles. The results coincide precisely with experimental data (not shown) up to  $10^6$  seconds, after which there are no further experimental data points. Note that at short times, the  $90^\circ$  lamina is the most compliant as would be expected, but as time progresses the  $45^\circ$  lamina becomes actually more compliant than the  $90^\circ$ . This occurs because even though the shift rates of the transverse and shear compliance were taken to be the same for this illustration (in fact, they differ) and thus the effective time for both terms is identical, the  $S_{66}$  term which dominates the  $45^\circ$  response is more compliant in the long term than the  $S_{22}$  term.

### **Aging of a Laminate**

The last portion of this work examined the response of composite laminates to physical aging. This was accomplished by incorporating the process of physical aging of a lamina (from the previous section) into standard lamination theory. This work is still ongoing, but a sample result is shown in Figure 7. Here the change in compliance of a quasi-isotropic laminate,  $[0/\pm 45/90]_S$ , is given over a long time range. Note that the compliance is now plotted on a semi-log scale since the changes in compliance are not as dramatic with fiber domi-

nated lay-ups. Notice, however, that the stiffnesses change by 8%-12% over a 10 year period, which is certainly significant for most structural applications, HSCT not excluded. Continuing work will examine sensitivity of the composite response to small changes of angle in the 0° lamina and investigate the effects of temperature on long-term aging of composites. Stress level dependencies will also be examined.

**References**

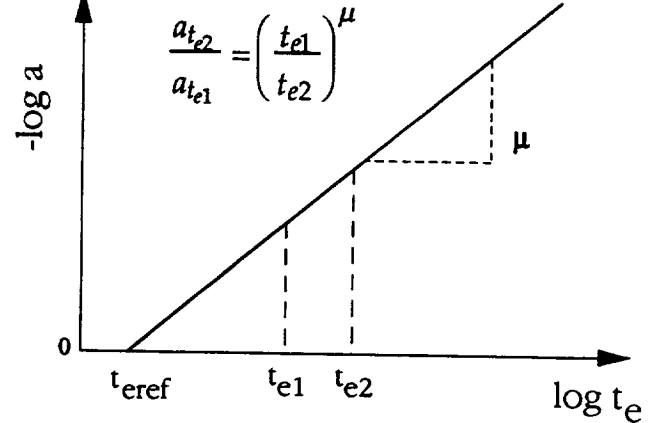
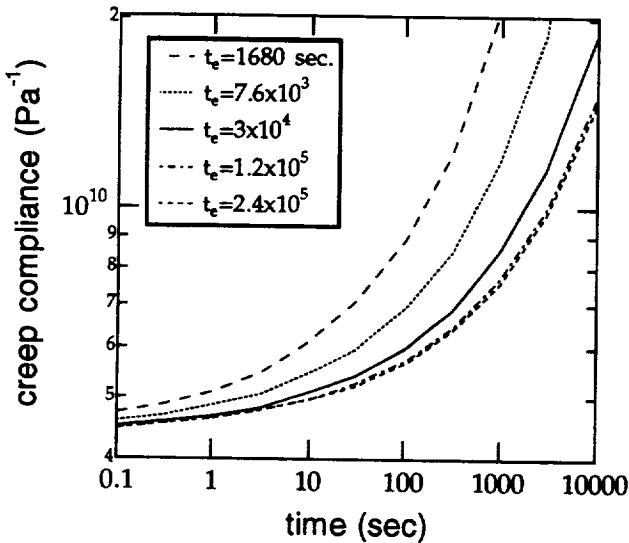
Gates, T. S. and Feldman, M., "The Effects of Stress and Physical Aging on the Creep Compliance of a Polymeric Composite," *34th AIAA SDM Conference*, vol. AIAA-93-1575-CP, Part 4, April 19-22, 1993, pp. 2348-2356.

Halpin, J. C., *Primer on Composite Materials Analysis*. Technomic Publishing Co., Lancaster. 2nd Edition, 1992.

Hastie, R. L. J., *The Effect of Physical Aging on the Creep Response of a Thermoplastic Composite*. Ph.D., Virginia Tech, 1991.

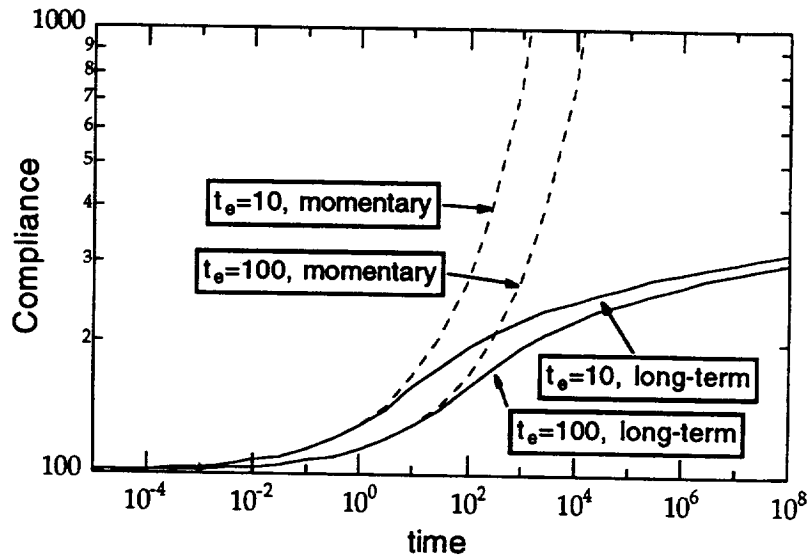
Lee, A. and McKenna, G. B., "The Physical Ageing Response of an Epoxy Glass Subjected to Large Stresses," *Polymer* 31, 1990, pp. 423-430.

Sruik, L. C. E., *Physical Aging in Amorphous Polymers and Other Materials*. Elsevier Scientific Publishing Co., New York. 1978.



**Figure 1:** Momentary creep curves with progressing aging time; McKenna data on epoxy.

**Figure 2:** Definition of Shift Rate



**Figure 3:** Comparison of long-term and momentary response



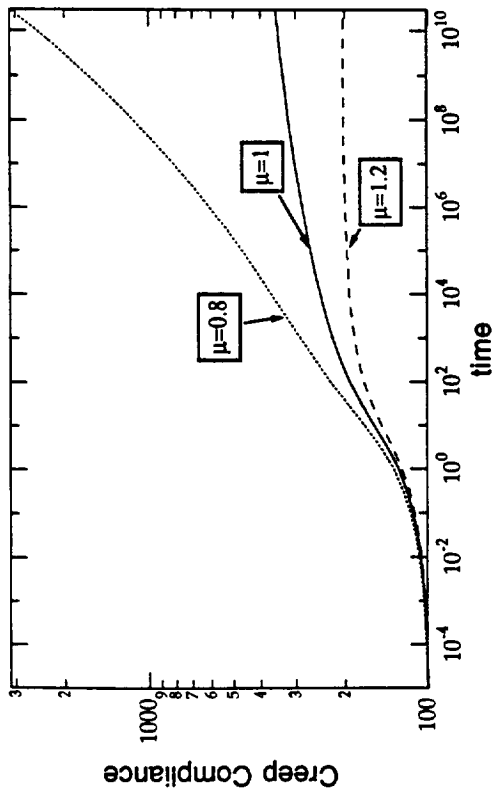


Figure 4: Effect of different shift rates on the long-term material response

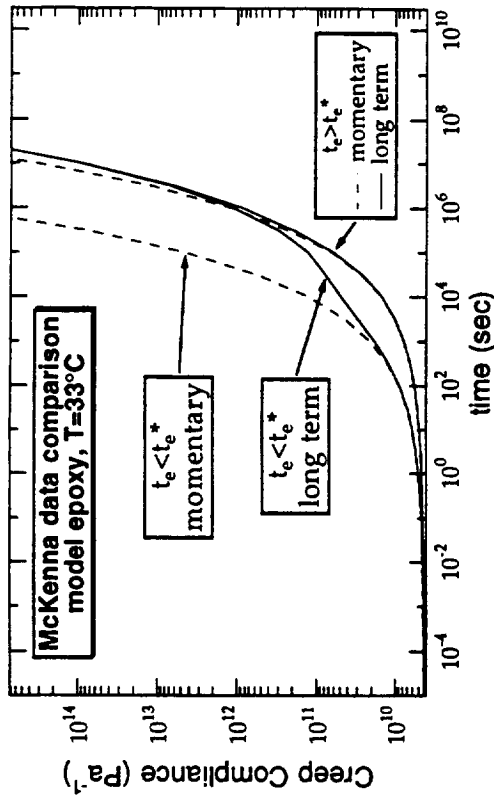


Figure 5: Momentary and long term response when aged to equilibrium

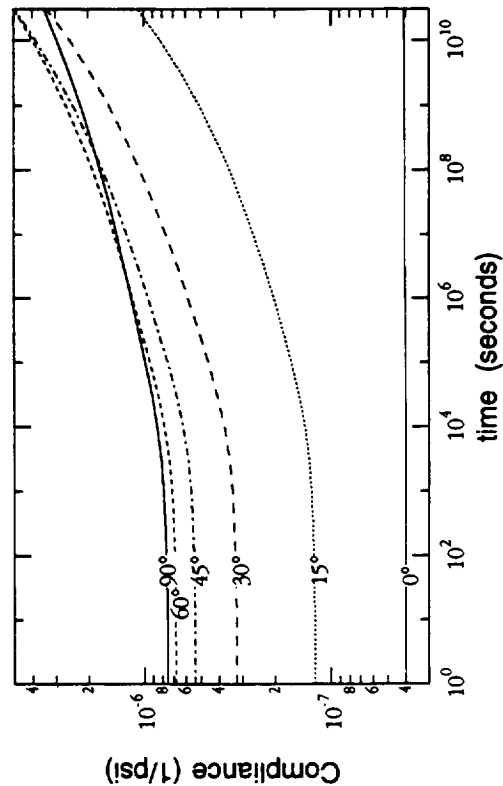


Figure 6: Comparison of the effect of aging on the long term compliance for varying fiber angles. Hastie data, on IM7/8320 with  $\mu_6 = \mu_2 = 0.77$ .

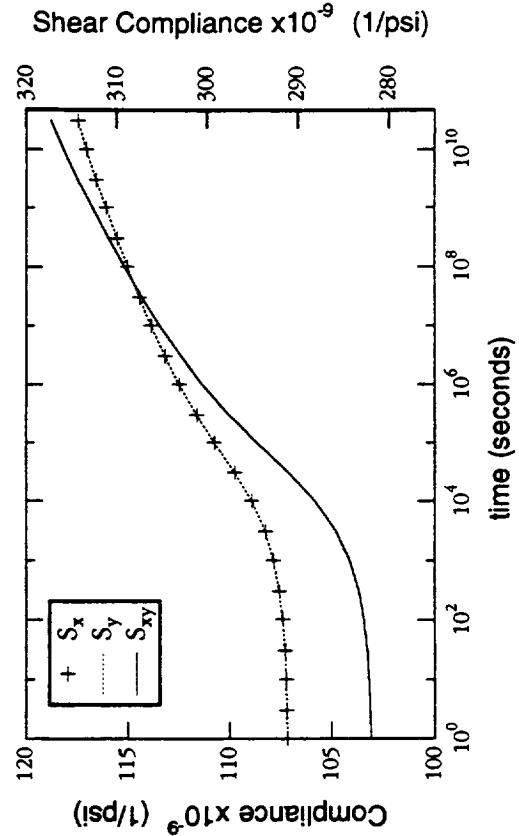


Figure 7: Change in compliance of quasi-isotropic laminate of IM7/8320.

**PROTON IRRADIATION ON MATERIALS**

by

Professor C. Ken Chang  
Department of Biology, Chemistry,  
and Environmental Science  
Christopher Newport University  
Newport News, Virginia 23606

**ABSTRACT**

A computer code is developed by utilizing a radiation transport code developed at NASA Langley Research Center to study the proton radiation effects on materials which have potential application in NASA's future space missions.

The code covers the proton energy from 0.01 Mev to 100 Gev and is sufficient for energetic protons encountered in both low earth and geosynchronous orbits. With some modification, the code can be extended for particles heavier than proton as the radiation source.

The code is capable of calculating the range, stopping power, exit energy, energy deposition coefficients, dose and cumulative dose along the path of the proton in a target material. The target material can be any combination of the elements with atomic number ranging from 1 to 92, or any compound with known chemical composition. The generated cross section for a material is stored and is reused in future to save computer time.

This information can be utilized to calculate the proton dose a material would receive in an orbit when the radiation environment is known. It can also be used to determine, in the laboratory, the parameters such as beam current of proton and irradiation time to attain the desired dosage for accelerated ground testing of any material.

It is hoped that the present work be extended to include polymeric and composite materials which are prime candidates for use as coating, electronic components and structure building. It is also desirable to determine, for ground testing these materials, the laboratory parameters in order to simulate the dose they would receive in space environments.

A sample print-out for water subject to 1.5 Mev proton is included as a reference.

\*\*\*\*\* WATER

ATOMIC NUMBERS = 1.000 8.000 0.000 0.000 0.000

STOICHIOMETRIC COEFFICIENTS = 2.000 1.000 0.000 0.000 0.000

ATOMIC DENSITIES, ATOMS/GM = 0.669E+23 0.334E+23 0.000E+00 0.000E+00 0.000E+00

TARGET THICKNESS, MIL; DENSITY, G/CM3 = 0.400E+01 1.000  
RANGE OF PROTON IN G/CM2 & MIL; ENERGY, MEV = 0.454E-02 0.179E+01 1.500

ONE PROTON PER CM2 ON TARGET

DISTANCE MIL	STOP. PWR MEV/G/CM2	PROTON E MEV	DOSE MEV	CUMM DOSE MEV	DOSE RAD	CUMM DOSE RAD
0.000E+00	0.196E+03	0.150E+01	0.505E-01	0.505E-01	0.796E-07	0.796E-07
0.100E+00	0.201E+03	0.145E+01	0.518E-01	0.102E+00	0.816E-07	0.806E-07
0.200E+00	0.207E+03	0.140E+01	0.533E-01	0.156E+00	0.839E-07	0.817E-07
0.300E+00	0.213E+03	0.134E+01	0.549E-01	0.210E+00	0.864E-07	0.829E-07
0.400E+00	0.219E+03	0.129E+01	0.566E-01	0.267E+00	0.892E-07	0.841E-07
0.500E+00	0.227E+03	0.123E+01	0.586E-01	0.326E+00	0.924E-07	0.855E-07
0.600E+00	0.235E+03	0.117E+01	0.609E-01	0.387E+00	0.959E-07	0.870E-07
0.700E+00	0.245E+03	0.111E+01	0.635E-01	0.450E+00	0.100E-06	0.886E-07
0.800E+00	0.256E+03	0.104E+01	0.666E-01	0.517E+00	0.105E-06	0.904E-07
0.900E+00	0.269E+03	0.977E+00	0.702E-01	0.587E+00	0.111E-06	0.925E-07
0.100E+01	0.284E+03	0.906E+00	0.744E-01	0.661E+00	0.117E-06	0.947E-07
0.110E+01	0.302E+03	0.832E+00	0.793E-01	0.741E+00	0.125E-06	0.972E-07
0.120E+01	0.323E+03	0.753E+00	0.854E-01	0.826E+00	0.135E-06	0.100E-06

# A Comprehensive Comparison of Turbulence Models in the Far Wake

by

Professor John M. Cimbala  
 Mechanical Engineering Department  
 The Pennsylvania State University  
 University Park, PA 16802

## Abstract

In the present study, the far wake was examined numerically using an implicit, upwind, finite-volume, compressible Navier-Stokes code. The numerical grid started at 500 equivalent circular cylinder diameters in the wake, and extended to 4000 equivalent diameters. By concentrating only on the far wake, the numerical difficulties and fine mesh requirements near the wake-generating body were eliminated. At the time of this writing, results for the  $K-\epsilon$  and  $K-\omega$  turbulence models at low Mach number have been completed, and show excellent agreement with previous incompressible results and far-wake similarity solutions. The code is presently being used to compare the performance of various other turbulence models, including Reynolds stress models and the new anisotropic two-equation turbulence models being developed at NASA Langley. By increasing our physical understanding of the deficiencies and limits of these models, it is hoped that improvements to the universality of the models can be made. Future plans include examination of two-dimensional *momentumless* wakes as well.

## Introduction

**Purpose** The author is an experimentalist by background, so the primary purpose of this ASEE Summer Faculty Fellowship was for him to obtain some experience with computational fluid dynamics (CFD). Towards this end, the two-dimensional far wake was chosen as a good test flow on which to practice computations and learn more about turbulence modeling. The author will remain here at NASA Langley during the academic year 1993-94 (on sabbatical leave) to continue these studies and to perform numerical calculations on other flows as well.

**Flow Field** The turbulent far wake of a two-dimensional body was chosen since there has been extensive experimental study of this flow, and since there is a known analytical solution very far downstream<sup>1</sup>. If turbulence in the wake could be properly modeled, a CFD code would predict both spreading rate and velocity profiles which would match those of experiment. Unfortunately, even for such a simple flow, none of the popular turbulence models in use today yield CFD predictions which match experimental results. For example, the standard two-equation turbulence models ( $K-\epsilon$  and  $K-\omega$ ) perform reasonably well at predicting the mean velocity and turbulent kinetic energy profile shapes in the two-dimensional far wake, but they do a poor job at predicting the *spreading rate* of the far wake<sup>2</sup>.

In the present study, the wake-generating body was not included in the computational space; rather, the inlet was chosen at a location far enough downstream where the wake is already fully developed. This choice enabled comparison of the performance of turbulence models, without the requirement of a huge number of grid points. The inlet conditions were taken from the experimental data of Browne, Antonia, and Shah<sup>3,4</sup>, who conducted extensive measurements in the far wake of a circular cylinder.

**Grid** The numerical grid began at approximately 500 equivalent circular cylinder diameters downstream of the wake-generating body, where the wake is already fully developed. 101 grid points were sufficient in the streamwise ( $x$ ) direction, and 51 in the normal ( $y$ ) direction. Parametric studies of grid resolution showed that neither a  $201 \times 51$  grid (twice the number of grid points in the  $x$  direction) nor a  $101 \times 101$  grid (twice the number of grid points in the  $y$  direction) had any significant effect on the results. The  $101 \times 51$  grid corresponded to an executable program which was small enough ( $< 10$  Mwords) to run on NASA Langley's Cray Y-MP ("sabre") interactively. In the code, both  $x$  and  $y$  were normalized by  $b_0$ , the wake half width at the inlet.  $b$  is defined as the  $y$  location where the mean streamwise velocity is half-way between its minimum at the centerline and its maximum in the freestream. The grid was stretched geometrically in the  $y$  direction from  $y/b_0 = 0$  (centerline) to  $y/b_0 \approx 10$  times the *local* wake half width,  $b$ , which was assumed to grow as  $\sqrt{x}$ , as is known from both experiment and similarity solutions of the far wake. The grid was also stretched in the  $x$  direction as  $\sqrt{x}$ . For the case studied here, the inlet corresponded to a distance of 100 inlet wake half widths from the wake-generating body. The grid extended therefore from  $x/b_0 = 100$  to  $x/b_0 = 800$ , which is equivalent to 500 to 4000 circular cylinder diameters. A plot of the grid is shown in Figure 1.

**CFD Code** The code used in the present study was written by Joe Morrison, and is an implicit, upwind, finite-volume, compressible Navier-Stokes code. Details about the numerical scheme and the performance of the code are

described in Morrison<sup>5</sup> and Morrison and Gatski<sup>6</sup>. Although the code was written for compressible flows, the Mach number was set very low (typically 0.2 or lower) so that the effects of compressibility were negligible. (This was verified by repeating the calculations at several Mach numbers.) All calculations to date have been steady-state, and have been restricted to two dimensions, although the code is capable of solving three-dimensional, time-dependent flows.

## Results

To date, the code has been run with both the K- $\epsilon$  and K- $\omega$  turbulence models. Self-similar wake profiles were obtained by the following scheme:

1. The best available data<sup>2,3</sup> were supplied at the inlet of the computational domain (i.e. at  $x/b_0 = 100$ ).
2. The code was run until convergence. However, the downstream profiles (U, V, K, and either  $\epsilon$  or  $\omega$ , depending on which turbulence model was used) did not attain self-similarity with the profiles supplied as inlet conditions. Note that this was not entirely unexpected, since some of the input variables (particularly dissipation  $\epsilon$  and pressure P) are extremely difficult to measure, and were not correct self-similar profiles at the start.
3. The profiles at a downstream station of  $x/b_0 = 400$  were re-normalized and fed back into the code as modified inlet conditions. The code was then run again, using these modified inlet conditions, and using the output from the previous run as the initial guess for the new run (to speed up convergence).
4. Step 3 was repeated several times (typically six or seven runs were required) until the entire solution converged. In other words, when the correct inlet profiles for a self-similar far wake were specified as inlet conditions, the wake developed further downstream in an exactly self-similar manner, consistent with the specified inlet conditions.

Upon convergence of the solution, plots of the normalized profiles of U, K,  $\epsilon$ , and  $\omega$  at every x location collapsed onto the same curves, indicating complete self-similarity. Examination of the spreading rate of the wake could then be performed. Results for the K- $\epsilon$  turbulence model are shown in Figures 2 and 3. Figure 2 shows how the centerline velocity defect decays as  $\sqrt{x}$ , while the wake half width grows as  $\sqrt{x}$ . Figure 3 shows the curve fit used to determine the nondimensional spreading rate for the wake. The spreading rate was found to be 0.257. For comparison, Wilcox<sup>2</sup> found a spreading rate of 0.256 using the same turbulence model, but assuming a self-similar solution from the start. This agreement is encouraging since no such assumption was necessary in the present calculations; i.e. the self-similar state was predicted by the full Navier-Stokes code, provided that the inlet conditions were correct.

## Conclusions and Plans for Future Work

At the time of this writing, it has been verified that the CFD code being used can accurately predict the growth of a simple shear flow, such as a turbulent far wake. The solutions, though consistent with previous calculations of others, do not match experimentally observed growth rates. The reason for this discrepancy is not due to the code itself, but rather to non-universality of the turbulence models. In other words, the turbulence models do not contain enough information to adequately model the physics of the flow, and thus the numerical predictions are only as good as the turbulence model itself. This is an ideal situation for comparison of various turbulence models.

In the next few months, several other turbulence models will be tested on this same flow field. These will include the more sophisticated Reynolds stress models and the new anisotropic two-equation turbulence models being developed at NASA Langley<sup>7</sup>. Only by increasing our physical understanding of the deficiencies and limits of these models can improvements to the universality of the models be made. Future plans include examination of the two-dimensional *momentumless* wake as well. This case is even more difficult to predict numerically, since the mean shear decays extremely rapidly downstream.

## References

1. Schlichting, H. *Boundary Layer Theory* (1962) 6th ed., McGraw-Hill, New York.
2. Wilcox, D. C. *Turbulence Modeling for CFD* (1993) DCW Industries, Inc., La Canada, CA.
3. Browne, L. W. B., Antonia, R. A. Anisotropy of the Temperature Dissipation in a Turbulent Wake, *J. Fluid Mech.* (1986) 163, pp. 393-403.
4. Antonia, R. A. and Browne, L. W. B., Shah, D. A. Turbulent Energy Dissipation in a Wake, *J. Fluid Mech.* (1987) 179, pp. 307-326.
5. Morrison, J. H. (1992) A Compressible Navier-Stokes Solver with Two-Equation and Reynolds Stress Turbulence Closure Models, NASA Cont. Rep. 4440.
6. Morrison, J. H. and Gatski, T. B. (1993) *Bull. Am. Phys. Soc.*, 38.
7. Gatski, T. B. (1993) Private Communication, NASA Langley Research Center.

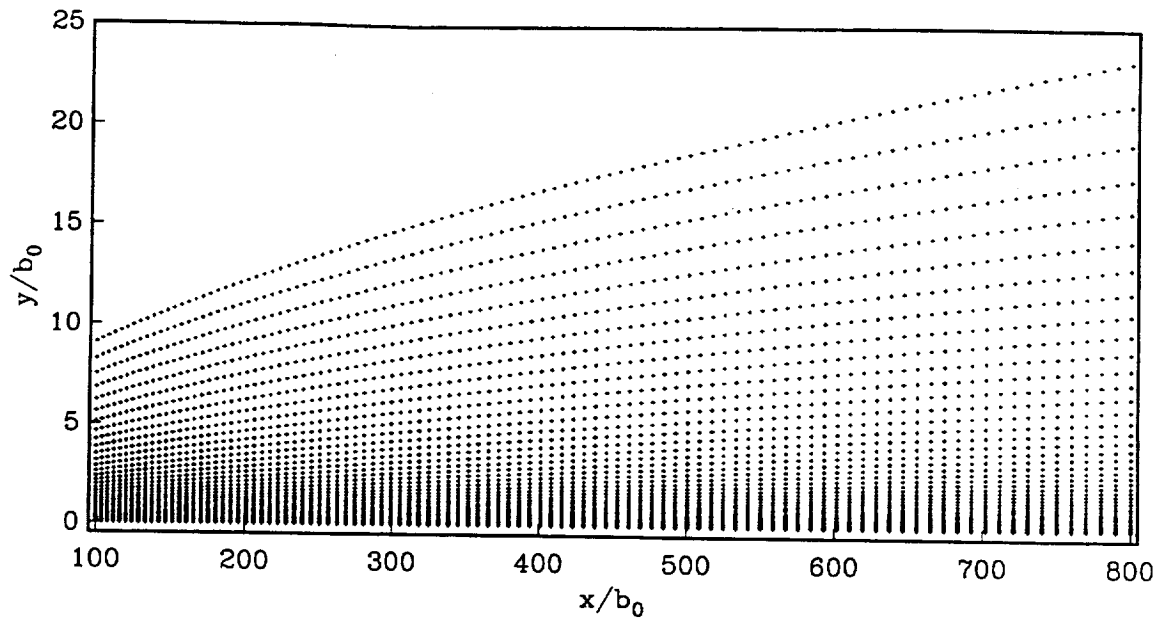


Figure 1. Grid generated for turbulence model study; 2-D wake.

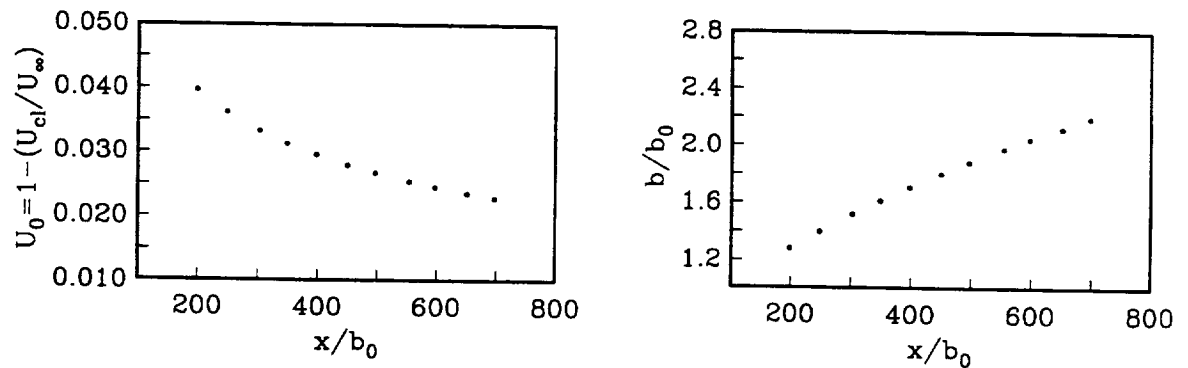


Figure 2. Streamwise development of velocity defect and wake halfwidth.

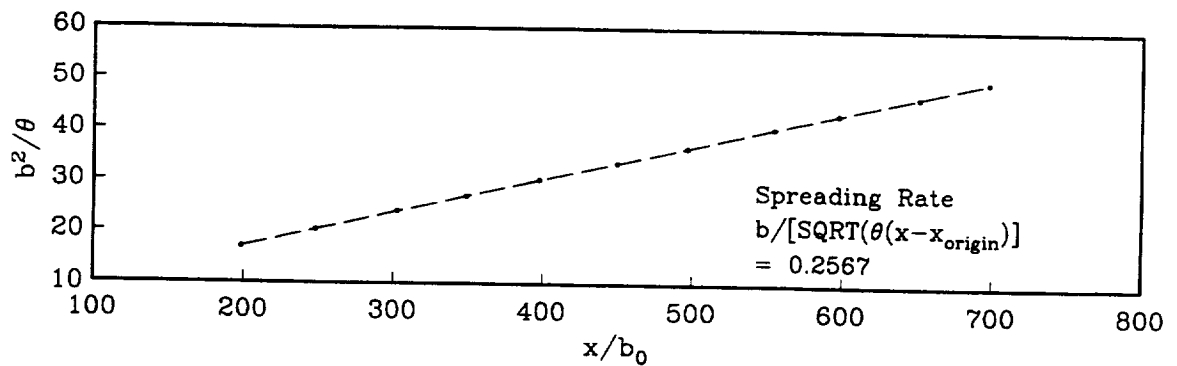


Figure 3. Curve fit for calculation of wake spreading rate.

AN EXPERIMENTAL INVESTIGATION OF FATIGUE DAMAGE IN  
ALUMINUM 2024-T3 ALLOYS

by

Professor Milton W. Ferguson  
Department of Chemistry and Physics  
Norfolk State University  
Norfolk, Virginia 23504

Aluminum alloys are finding increasing use in the aerospace and automobile industries due to their attractive low density-high modulus and low density-high strength characteristics. Unfortunately, cyclic stress-strain deformation alters the microstructure of the material. These structural changes can lead to fatigue damage and ultimately service failure. Therefore, in order to assess the integrity of the alloy, a correlation between fatigue damage and a measurable microstructural property is needed.

Aluminum 2024-T3, a commonly used commercial alloy, contains many grains (individual crystals) of various orientations. The sizes and orientations of these grains are known to affect the strength, hardness, and magnetic permeability of polycrystalline alloys and metals (ref. 1); therefore, perhaps a relationship between a grain property and the fatigue state can be established. Tension-compression cycling in aluminum alloys can also induce changes in their dislocation densities. These changes can be studied from measurements of the the electrical resistivities of the materials. Consequently, the goals of this investigation were:

1. To study the grain orientation of aluminum 2024-T3 and to seek a correlation between the grain orientation and the fatigue state of the material.
2. To measure the electrical resistivities of fatigued samples of aluminum 2024-T3 and to interpret the findings.

X-ray diffraction analysis is an indicator of structural changes in materials due to deformations (ref. 2). However, in the present investigation, normal x-ray scans of aluminum 2024-T3 samples fatigued from 1,000 cycles to 300,000 cycles remained virtually unchanged. An especially sensitive technique for crystal structure analysis, the x-ray rocking curve (XRC), was then used to characterize the samples. The XRC is initiated by scanning the sample to find the Bragg angles. Subsequently, the

sample is mounted on a goniometer at a particular Bragg angle and irradiated by a highly monochromatic x-ray beam while being rotated ("rocked") step by step about this angle. A plot of the reflecting power as a function of the angle between the sample surface and the incident x-ray is the rocking curve. The width of the rocking curve is a direct measure of the range of orientation of the grains present in the irradiated area of the sample. An increase in the width can also be correlated to an increase in the excess dislocation density of the material.

The electrical resistivity measurements were made using a "linear four-point probe". A direct current passed between two of the probes causes a potential difference between the other two probes. The resistivity is proportional to the ratio of the potential difference to the current, the proportional factor being dependent on the geometry of the probe array and the sample (ref. 3).

Fatiguing is believed to increase the excess dislocation density in the sample, thereby, causing the width of the rocking curve to increase with an increase in the number of fatigue cycles. Unexpectedly, the width of the XRC decreased. One explanation is that the samples annealed themselves after the fatiguing process, causing a reordering of the atoms into less distorted grains. The electrical resistivity measurements supported this explanation by decreasing as the fatigue state increased. Work is in progress to evaluate the effects of lapping on the width of the rocking curves and the resistivities of the samples.

#### References

1. B. D. Cullity, Elements of X-ray Diffraction, Addison-Wesley (1978).
2. J. Chaudhuri, V. Gondhalekar, A. Inchekel, and J. E. Talia, "X-Ray Rocking Curve Analysis of the Aging and Deformation Characteristics in the Al-Li Alloy," SAE Paper No. 891057, 1989.
3. F. M. Smits, "Measurement of Sheet Resistivities with the Four-Point Probe," The Bell System Technical Journal, May 1953, p. 711.



**Brain Wave Correlates of Attentional States:  
Event Related Potentials and Quantitative EEG Analysis  
During Performance of Cognitive and Perceptual Tasks**

by

Professor Frederick G. Freeman  
Department of Psychology  
Old Dominion University  
Norfolk, VA 23529

**Abstract**

The increased use of automation in the cockpits of commercial planes has dramatically decreased the workload requirements of pilots, enabling them to function more efficiently and with a higher degree of safety. Unfortunately, advances in technology have led to an unexpected problem: the decreased demands on pilots have increased the probability of inducing "hazardous states of awareness". A hazardous state of awareness is defined as a decreased level of alertness or arousal which makes an individual less capable of reacting to unique or emergency types of situations. These states tend to be induced when an individual is not actively processing information. Under such conditions a person is likely to let his/her mind wander, either to internal states or to irrelevant external conditions. As a result, they are less capable of reacting quickly to emergency situations. Since emergencies are relatively rare, and since the highly automated cockpit requires progressively decreasing levels of engagement, the probability of being seduced into a lowered state of awareness is increasing. This further decreases the readiness of the pilot to react to unique circumstances such as system failures. The HEM Lab at NASA-Langley Research Center has been studying how these states of awareness are induced and what the physiological correlates of these different states are. Specifically, they have been interested in studying electroencephalographic (EEG) measures of different states of alertness to determine if such states can be identified and hopefully, avoided.

The study of EEG in the HEM lab has involved two basic aspects of brain waves. First, there is the quantitative analysis of EEG recorded from 21 different electrode sites on the scalp. Basically, EEG is recorded and a Fast Fourier Analysis is performed on the recordings. When someone is drowsy, alpha waves (8-13 Hz) are typically seen, especially over the occipital lobe of the brain. When a person is awake and aroused, beta waves (13-30 Hz) are observed. With the use of the EEG brain mapper in the HEM Lab, different patterns of arousal across the cortex can be assessed and related to different categories of alertness.

The second basic aspect of brain waves are event related potentials (ERPs). These are electrical responses to discrete visual or auditory conditions presented to the subject as task-relevant or task-irrelevant stimuli. Over the course of 500-1000

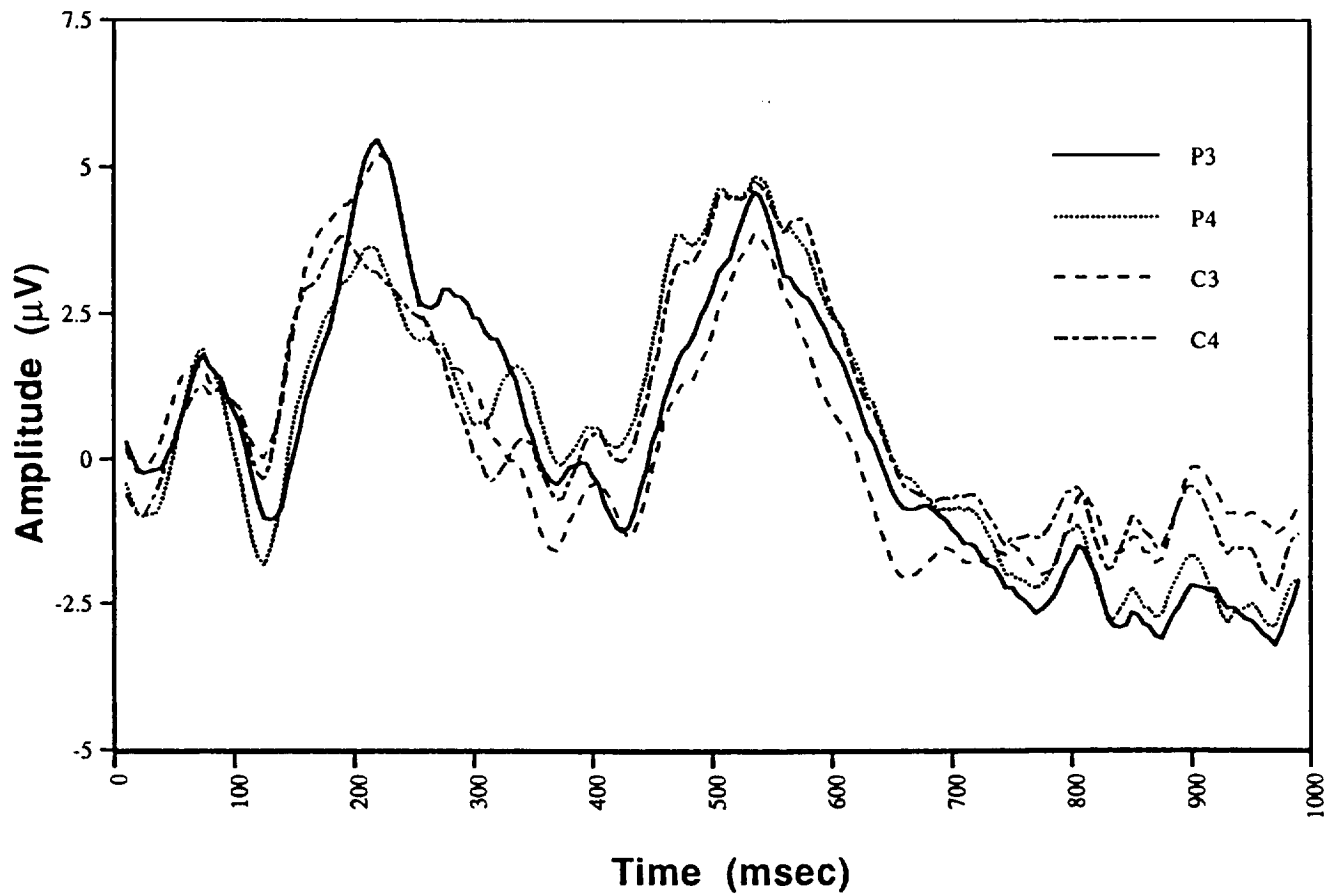
msec, different waveforms can be seen which reflect levels of attention and awareness.

The project worked on this summer involved analyzing the EEG and the ERP data collected while subjects performed under two conditions. Each condition required subjects to perform a relatively boring vigilance task. The purpose of using these tasks was to induce a decreased state of awareness while still requiring the subject to process information. Each task involved identifying an infrequently presented target stimulus. In addition to the task requirements, irrelevant tones were presented in the background. Research has shown that even though these stimuli are not attended, ERPs to them can still be elicited. The amplitude of the ERP waves has been shown to change as a function of a person's level of alertness. ERPs were also collected and analyzed for the target stimuli for each task. Brain maps were produced based on the ERP voltages for the different stimuli. In addition to the ERPs, a quantitative EEG (QEEG) was performed on the data using a Fast Fourier technique to produce a power spectral analysis of the EEG. This analysis was conducted on the continuous EEG while the subjects were performing the tasks. Finally, a QEEG was performed on periods during the task when subjects indicated that they were in an altered state of awareness. During the tasks, subjects were asked to indicate by pressing a button when they realized their level of task awareness had changed. EEG epochs were collected for times just before and just after subjects made this response. The purpose of this final analysis was to determine whether or not subjective indices of level of awareness could be correlated with different patterns of EEG.

In Figures 1 and 2 can be seen some representative results. ERPs to the target stimuli can be seen in Figure 1. The four lines represent recordings from different cortical sites. "C" stands for electrode placements over the central part of the skull while "P" stands for placements over the parietal lobes. Odd numbers are for placements over the left hemisphere and even numbers the right hemisphere. The data demonstrate a larger positive wave around 200 msec over the right hemisphere. In Figure 2 is shown a representative epoch of the EEG and accompanying maps recorded during one of the tasks. The maps demonstrate the amount of power in each wave band. Lighter areas of the maps indicate more power for the band.

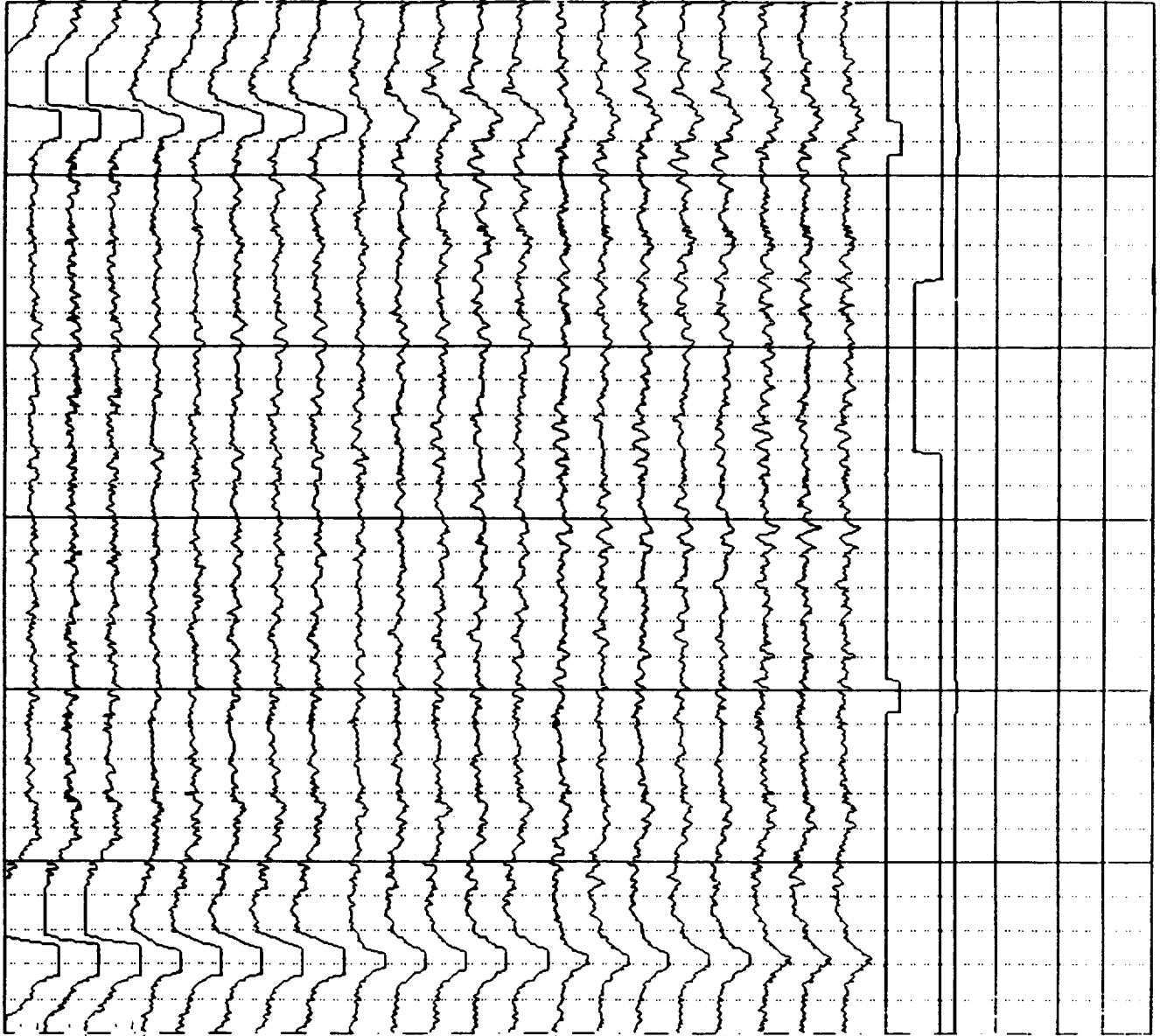
The research described represents part of a systematic investigation concerning "hazardous states of awareness". Future research will involve different methodologies for assessing subjective states and correlating them with EEG and behavioral measures.

## ERPs Perceptual Task Target Stimulus

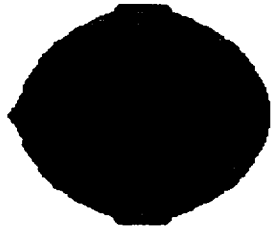


75uV  
1.0sec beckman.o

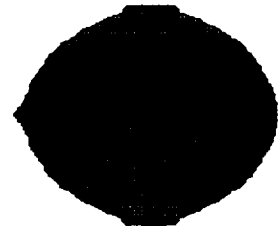
00:00:27



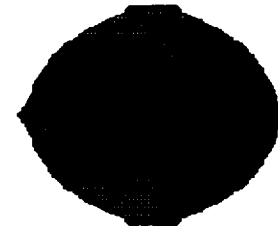
delta



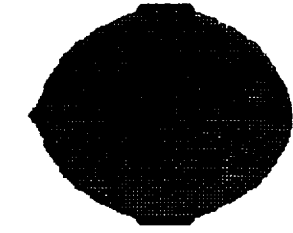
theta



alpha



beta



## Investigation of Aerodynamic Design Issues with Regions of Separated Flow

by

Dr. Tom Gally  
Aerospace Engineering Department  
Texas A&M University  
College Station, TX 77843

### Abstract

Existing aerodynamic design methods have generally concentrated on the optimization of airfoil or wing shapes to produce a minimum drag while satisfying some basic constraints such as lift, pitching moment or thickness. Since the minimization of drag almost always precludes the existence of separated flow, the evaluation and validation of these design methods for their robustness and accuracy when separated flow is present has not been aggressively pursued. However, two new applications for these design tools may be expected to include separated flow and the issues of aerodynamic design with this feature must be addressed.

The first application of the aerodynamic design tools is the design of airfoils or wings to provide an optimal performance over a wide range of flight conditions (multi-point design). While the definition of "optimal performance" in the multi-point setting is currently being hashed out, it is recognized that given a wide enough range of flight conditions, it will not be possible to ensure a minimum drag constraint at all conditions, and in fact some amount of separated flow (presumably small) may have to be allowed at the more demanding flight conditions. Thus a multi-point design method must be tolerant of the existence of separated flow and may include some controls upon its extent.

The second application is in the design of wings with extended high speed buffet boundaries of their flight envelopes. Buffet occurs on a wing when regions of flow separation have grown to the extent that their time varying pressures induce possible destructive effects upon the wing structure or adversely effect either the aircraft controllability or the passenger comfort. A conservative approach to the expansion of the buffet flight boundary is to simply expand the flight envelope of non-separated flow under the assumption that buffet will also thus be alleviated. However, having the ability to design a wing with separated flow and thus to control the location, extent and severity of the separated flow regions may allow aircraft manufacturers to gain an advantage in the early design stages of an aircraft, when configuration changes are relatively inexpensive to make.

The goal of my summer research at NASA Langley Research Center (LaRC) was twofold: first, to investigate a particular airfoil design problem observed under conditions of strong shock induced flow separation on the upper surface of an airfoil at transonic conditions; and second, to suggest and investigate design methodologies for the prediction (or detection) and control of flow separation. The context of both investigations was to use an existing 2-D Navier-Stokes<sup>1</sup> flow solver and the constrained direct/iterative surface curvature (CDISC)<sup>2-3</sup> design algorithm developed at LaRC. As a lead in to the primary tasks, it was necessary to gain a familiarity with both the design method and the computational analysis and to perform the FORTRAN coding needed to couple them together.

The airfoil design problem of interest had been observed by Yu and Campbell<sup>4</sup> using the same flow solver with an unconstrained version of the design algorithm called simply DISC<sup>2</sup>. The problem occurred when attempted to design an airfoil to a given pressure distribution obtained from a known airfoil geometry and at a flight condition where a significant amount of shock induced separation was present. Thus, this design attempt was a test to see if the known geometry could be regenerated from its pressure distribution by the design method. The resulting designed surface closely matched the target surface except for an additional hump on the new surface in the region of the shock and separated flow. Yu hypothesized that this feature was an attempt by the design algorithm to enclose the separation flow recirculation within the airfoil surface and that this new surface geometry was a permissible (although not desirable) alternate solution to the inverse design problem. Further, Yu suggested that the CDISC design concept which uses linear assumptions to relate changes in

streamline curvature to changes in desired pressure or pressure gradients may not be used in regions where the flow streamlines do not follow the surface shape, i.e. separated flow regions.

While this explanation seems physically plausible and may be a contributing factor to the observed phenomena, the current investigation indicates that a more likely explanation for the surface hump feature was a more common problem; that of using localized surface irregularities to force a particular shock location. In the current investigation, the hump feature obtained by Yu could be recreated only sporadically and appears to be sensitive to small changes in target pressure distribution. In particular, the hump feature only appeared when small differences between target and design shock locations and/or shock pressure gradients resulted in large surface curvature changes of opposite sign to be applied by the design method. Thus, the design method attempts to locally distort the airfoil surface to control the position and features of the shock. Differing methods were tried which alleviated the sensitivity of the design method to exactly match either pressures or pressure gradients in the shock jump. All of these changes reduced or removed the hump feature while still yielding good agreement between desired and target pressures. The conclusion is that the enclosure of separation regions is general behavior and further, since the conditions considered were more severe than those of Yu, the CDISC design algorithms do not have an observed problem in separated flow regions.

The next task of developing design methods which include separated flow constraints began with considering the simplest problem of specifying fully attached flow as a design constraint. A logic flow chart was developed and from it was identified specific topics which need to be addressed. The first of these is the efficient prediction of profile or shock induced separation from only a pressure profile, and inversely, the specification of a pressure profile to avoid separation. For the case of profile separation, the methods of Stratford<sup>5,6</sup> for incompressible flow are generally believed to be adequate although some "tuning" of parameters may be necessary to match specific situations. Keith et al.<sup>7</sup> have suggested a compressibility modification to Stratford's separation criteria. However, the Stratford separation criteria predicts separation in almost all shock/boundary layer interactions, even those for which experiment or analysis do not show separation. A number of modifications to the basic method have been made to improve the correlation to analysis. As present, no single method has worked in all situations, but it seems likely that one of the modifications could be selected and internally adjusted during an analysis to provide good agreement.

#### References

- 1) Swanson, R. C. and Turkel, E., "Artificial Dissipation and Central Difference Schemes for the Euler and Navier-Stokes Equations," AIAA Paper 87-1107-CP, June 1987.
- 2) Campbell, R. L. and Smith, L. A., "A Hybrid Algorithm for Transonic Airfoil and Wing Design," AIAA Paper 87-2552-CP, Aug. 1987.
- 3) Campbell, R. L., "An Approach to Constrained Aerodynamic Design with Application to Airfoils," NASA Technical Paper 3260, November 1992.
- 4) Yu, N. J. and Campbell, R. L., "Transonic Airfoil and Wing Design using Navier-Stokes Codes," AIAA Paper 92-2651, Aug. 1992.
- 5) Stratford, B. S., "The Prediction of Separation of the Turbulent Boundary Layer," *Journal of Fluid Mechanics*, Vol. 5, Part 1, pp. 1-16, Jan. 1959.
- 6) Stratford, B. S., "An Experimental Flow with Zero Skin Friction throughout its Region of Pressure Rise," *Journal of Fluid Mechanics*, Vol. 5, Part 1, pp. 17-35, Jan. 1959.
- 7) Keith, J. S., Ferguson, D. R., Merkle, C. L., Heck, P. H., and Lahti, D. J., "Analytical Method for Predicting the Pressure Distribution About a Nacelle at Transonic Speeds," NASA CR-2217, March 1973.

**Microspheres for Laser Velocimetry in High Temperature Wind Tunnel**

by

Professor Anthony Ghorieshi  
Mechanical and Material Engineering Department  
Wilkes University  
Wilkes-Barre, PA 18766

The introduction of non-intrusive measurement techniques in wind tunnel experimentation has been a turning point in error free data acquisition. Laser velocimetry has been progressively implemented and utilized in various wind tunnels; e.g. subsonic, transonic, and supersonic. The success of the laser velocimeter technique is based on an accurate measurement of scattered light by seeding particles introduced into the flow stream in the wind tunnel. Therefore, application of appropriate seeding particles will affect, to a large extent the acquired data. The seeding material used depends on the type of experiment being run. Among the seeding material for subsonic tunnel are kerosene, Kaolin, and polystyrene. Polystyrene is known to be the best because of being solid particles, having high index of refraction, capable of being made both spherical and monodisperse. However for high temperature wind tunnel testing seeding material must have an additional characteristic that is high melting point. Typically metal oxide Powders such as  $Al_2O_3$  with melting point 3660 °F is being used. The metal oxides are however polydispersed, have a high density, and a tendency to form large agglomerate that does not closely follow the flow velocity. The addition of flame phase silica to metal oxide helps to breaks up the agglomerates, however, still results in a narrow band of polydispersed seeding. The less desirable utility of metal oxide in high temperature wind tunnels necessities the search for a better alternative particle seeding which this paper addresses.

The Laser Velocimetry (L. V.) characteristic of polystyrene makes it a prime candidate as a base material in achieving the high temperature particle seeding inexpensively. While polystyrene monodisperse seeding particle reported (1-2) has been successful in subsonic wind tunnel, but lacks the high melting point and thus is not practically usable in high temperature wind tunnel.

It is well known that rise in melting point of polystyrene can be achieved by cross-linking technique(3). Since polystyrene already posses all the desired characteristics for LV, to circumvent the low melting point, cross-linking technique was investigated.

**CROSS-LINKED POLYSTYRENE PREPARATION**

The ingredients in mixture are water as medium, magnesium sulfate electrolyte, styrene monomer, divinylbenzene (DVB) as cross-linking agent, and potassium Persulfate as initiator. The lack of established formulations for mixture opens the way for trial and error process. Therefore a polymerization process was chosen as starting point as follows:

1. A water bath filled with tap water was heated to reach 65°C, a pyrex reaction kettle was filled with 2370 (ml) high purity distilled water, 56 (ml) magnesium sulfate, 265 (ml) styrene and a volume of divinylbenzene as part of styrene volume. An agitator is placed in the reactor before it was covered.
2. The reactor is placed in the water bath for 40 minutes. During this period nitrogen gas is flowing through the mixture to purge oxygen with the agitator turning at a rate of 150 rpm.
3. Potassium Persulfate solution was added to the reactor at 65°C.
4. For cross-linking to take place, the mixture was run for 18 hours. At the end of this period the reactor was removed from the water bath and filtered through 100 mesh cheese cloth into a clean storage container.

The simplicity and very low cost of producing the seeding particles make this process, practically a "do-it-yourself" manufacturing, which is very attractive when compared to the commercial market of several hundreds of dollars per pound. However, this process is still in developing stages, and has a long way to be transferred from a trial and error process to a straight forward, well-established process. A well-established process requires known formulation of material solution for desired particle size in conjunction with detail specification of ever changing environmental parameters. The trial and error nature of this procedure require a large number of experimentation therefore twenty-four hours run were adopted. In general rate of success was 12.5% that is relatively good as first set of experimentation considering high number of affecting factors. They include five material solutions; water, magnesium sulfate, styrene, divinylbenzene, potassium persulfate, and at least five environmental factors that controls the condition in which beads are being produced: temperature of mixture, rotation rate of agitator, rate of flow of nitrogen into the mixture, kind and placement of the stirrer, and required time for desired bead size.

## RESULTS

The trial and error nature of this process were the cause of many surprises and produced from very thin transparent latex sheets' pieces too soft and delicate to snow like white flacks, and to golf ball size styrene spheres.

Early in the experimentation it was decided to keep all the parameters the same and vary the amount of divinylbenzene. The volume amount of divinylbenzene (DVB) has been varied from 5% to 0.1% of styrene volume. Experimentation using DVB 2% of styrene volume produced some beads, figure 1, while a close up view is shown in figure 2. In order to determine the melting point a sample was tested in Differential Scanning Calorimeter (DSC), figure 3, which illustrates there is not a melting point in the temperature range tested and in fact cross-linking has been accomplished even though at temperature of 103.61°C it has a phase two change. At this temperature the white sample changes to brown, at which it stays throughout until it decays. The temperature range of 0°C to 300 °C is the expected range of temperature in the wind tunnel. For comparison proposes, a sample of polystyrene was prepared and tested in DSC, figure 4, which indicates melting temperature of 193°C. Even though this run showed that the cross-linking is possible, the beads were too attached and crumbled together. They form a worm like shape even through among them existed individual spherical beads. Hence



the batch was generally not usable. To clarify this point a sample of non cross-linked polystyrene is shown in figure 5, which illustrates the polystyrene beads are monodisperse spherical shape of  $0.95 \mu$  diameter, on average.

Even though all the parameters except for DVB were kept constant, the results of the runs were not similar and at times there were not any beads produced at all or products existed in worm like form. This situation made most of the batches not usable. Another aspect of this process is the time it takes to finish a run, namely 18 hours on average, which limits the number of the runs that could be made. The reason for all this inconsistencies is related to fluctuations of environmental parameters, even though care was taken to keep them constant as well as it could be done. Affect of the factors such as vibration of bath tub, outside temperature etc. contributed to these fluctuation.

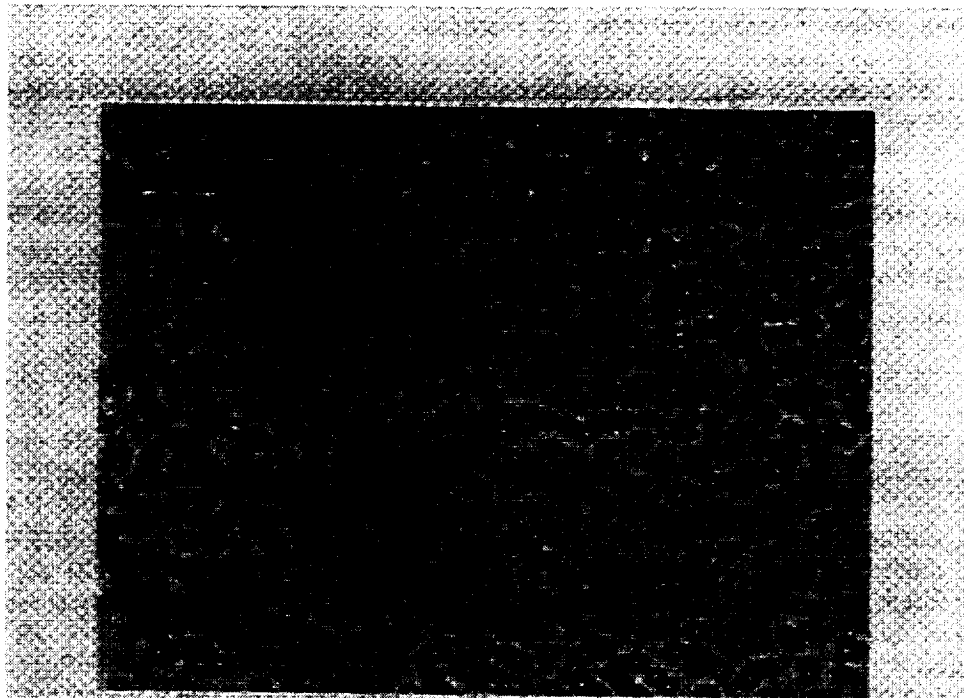
A major surprise was a run with DVB volume only 0.2% of styrene volume. The run was monitored every 2 hours for the first and last 8 hours. The sample taken after 4 hours clearly showed that beads were formed, figure 6. This figure indicates that beads are spherical. A computer based particle sizing technique was used to determine the size of the seeding spheres. Figure 7 demonstrates the monodispersity of the beads with average diameter of  $0.95 \mu$ . This run was sampled after 22 hours and contrary to forming larger and better product, there were only a few good beads shown distinctively, the rest being much smaller beads crumbled together or overlaid each other which made the result of this run an unusable batch, figure 8. For comparing purposes this run was repeated with exact amounts and monitored at the same intervals. Surprisingly, the 4 hours sample did not show any formulation of beads, figure 9. The 6 hours sample showed worm like beads formation, figure 10. The 19 hours sample illustrated the formation of beads, figure 11, however not as good as expected. The monodispersity of this sample is illustrated in figure 12. The beads are of size  $0.7 \mu$  and monodisperse. In general last two aforementioned runs indicate how sensitive the process is to unforeseen change.

## CONCLUSION

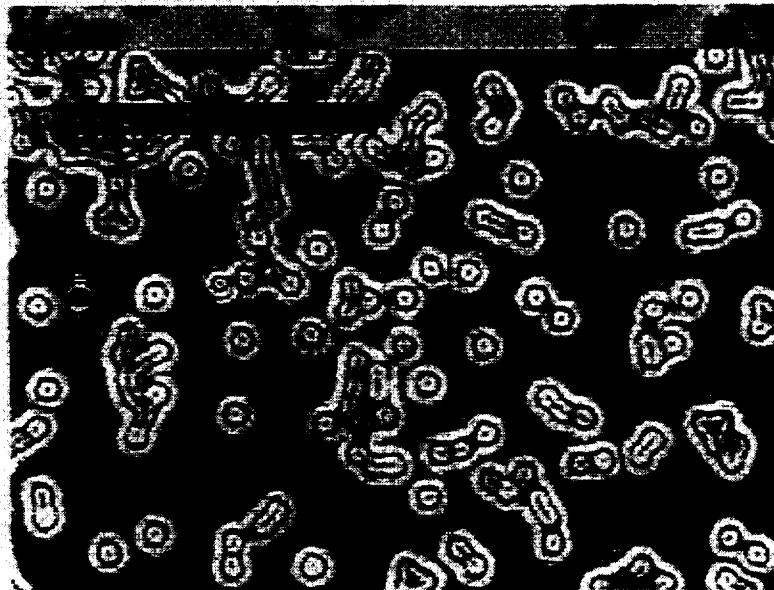
It was experimentally demonstrated that cross-linking of polystyrene does produce seeding particle for high temperature wind tunnel. Indeed among several runs that were made a few batch resulted in spherical beads with no melting point in the desired range of  $0^{\circ}\text{C}$  to  $300^{\circ}\text{C}$ . Considering the cost of the commercially available beads (a few dollar in oppose to hundreds of dollars per ten grams), good L. V. characteristics, and lightness in compare with metal oxides, the cross-linked polystyrenes particles makes a superior seeding candidate for high temperature and low temperature wind tunnels.

## REFERENCES

1. Nichols, Jr., C.E., "Preparation of Polystyrene Microspheres for Laser Velocimetry in Wind Tunnel", NASA Technical Memorandum, 89163, Jun(1987).
2. Ghorieshi, J. A., "Wind Tunnel Seeding Particles for Laser Velocimetry", NASA publication, Hampton, VA(1992).
3. Personal conversation with Warren C. Kelliher, Facility Engineering Division, NASA, Hampton, VA(1993)



**Figure 1. A sample of cross-linked beads using 5ml DvB**



**Figure 2. A close up of figure 1**

Sample: X-LINKED #1  
Size: 4.0000 mg  
Method: RT-300 20°C/MIN

DSC

File: 1341.01  
Operator: KAREN WHITLEY  
Run Date: 06/21/93 09:24

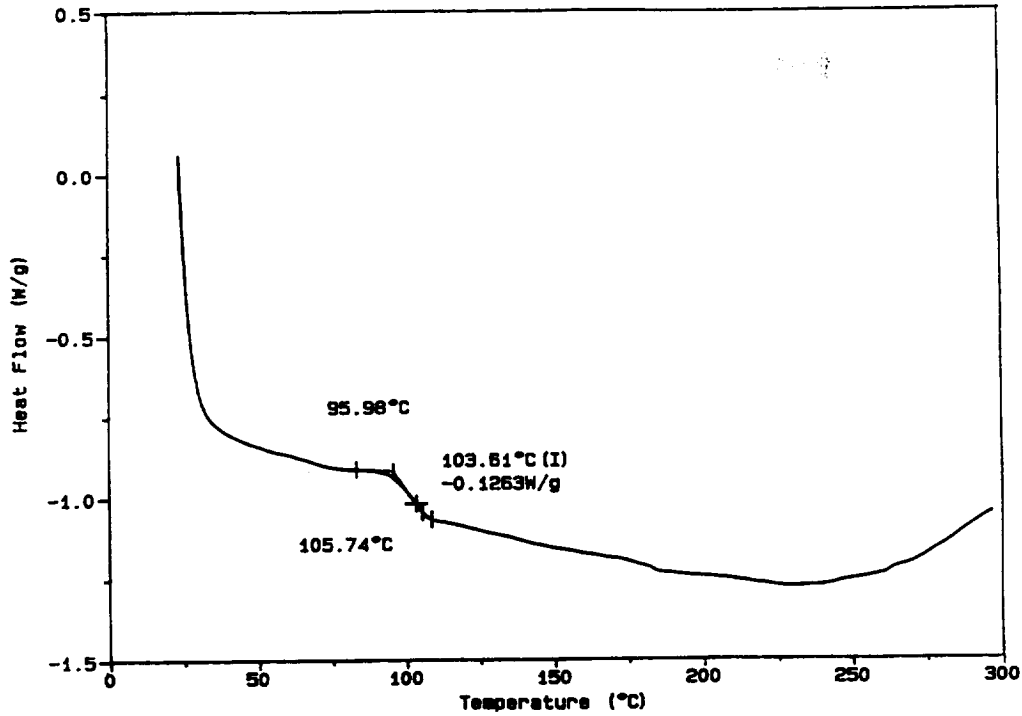


Figure 3. Cross-linked polystyrene temperature variation curve indicating no melting point

Sample: POLYSTYRENE  
Size: 4.8000 mg  
Method: RT-300 20°C/MIN

DSC

File: 1340.01  
Operator: KAREN WHITLEY  
Run Date: 06/18/93 14:51

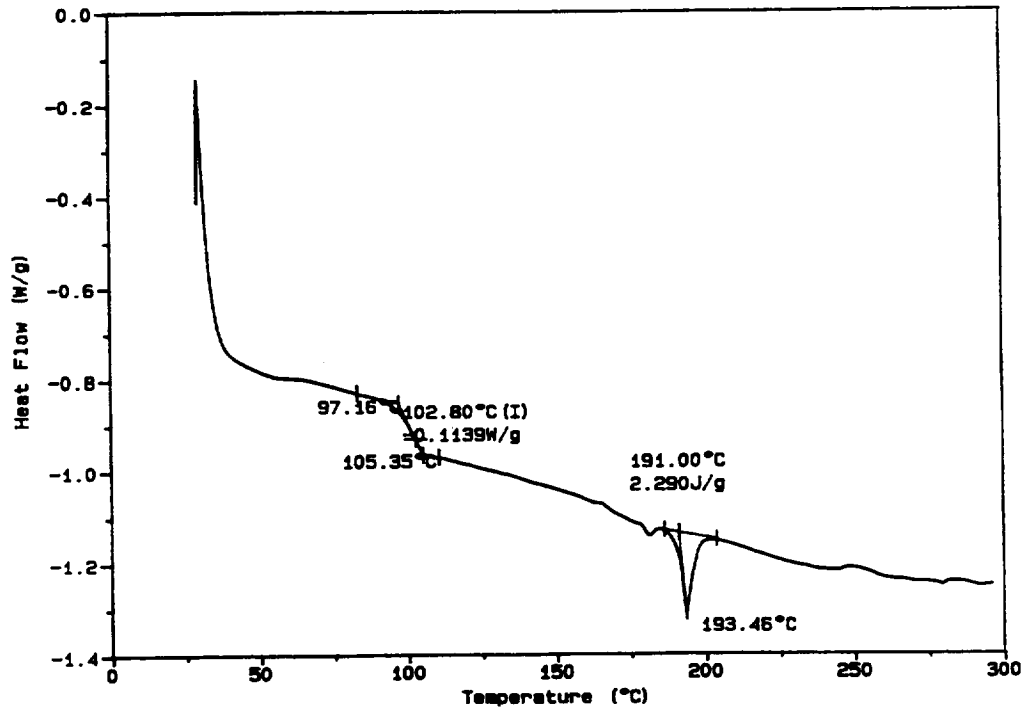
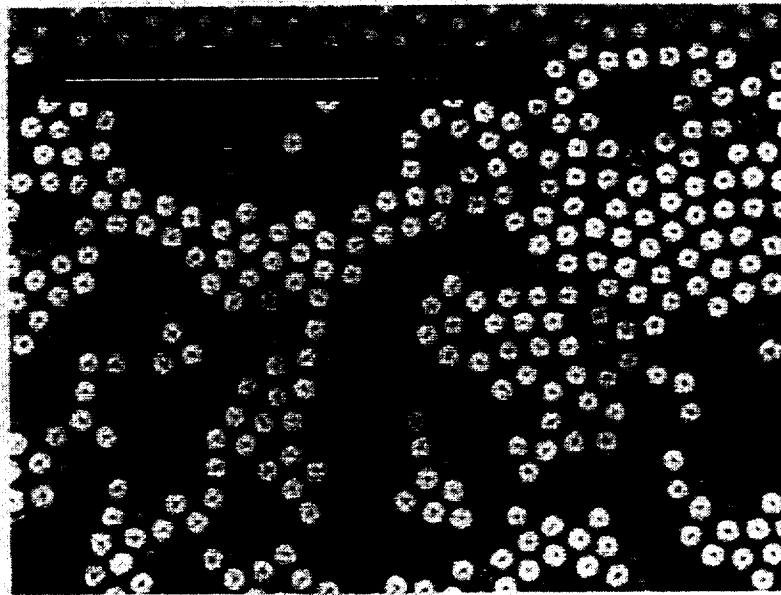
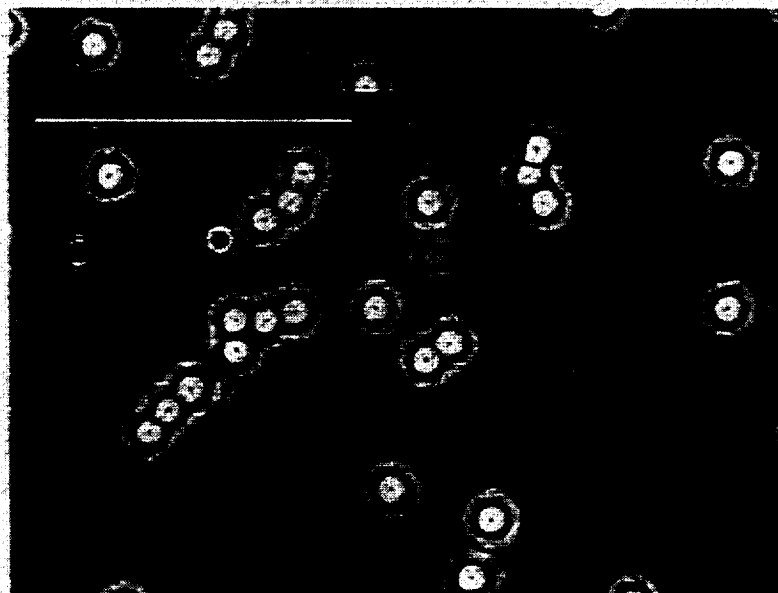


Figure 4. Polystyrene temperature variation curve indicating melting point of 193°C

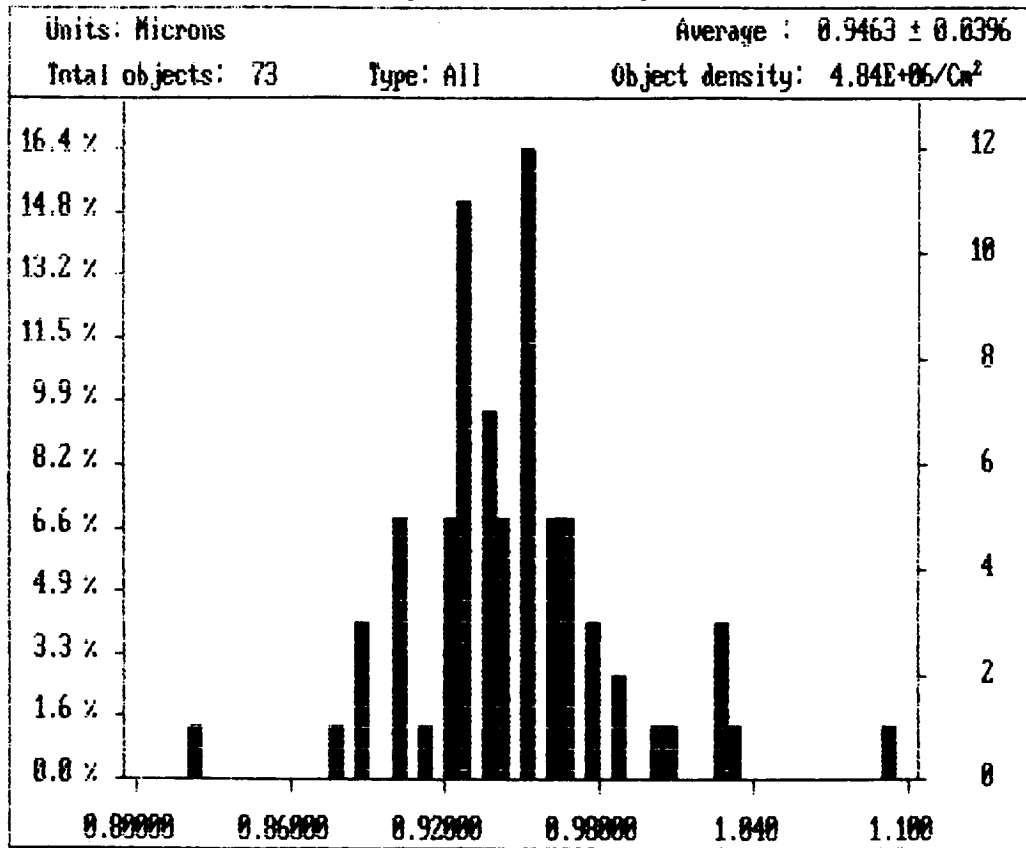


**Figure 5. Monodisperse spherical polystyrene beads of 0.95  $\mu$**



**Figure 6. Monodisperse, micro spheres cross-linked polystyrene beads**

Bar Histogram of Size (avg. ferets)



**Figure 7. Percent of various size beads produced, illustrating monodispersity beads size 0.95 μ (on average)**



Figure 8. A 22-hour sample showing few particles

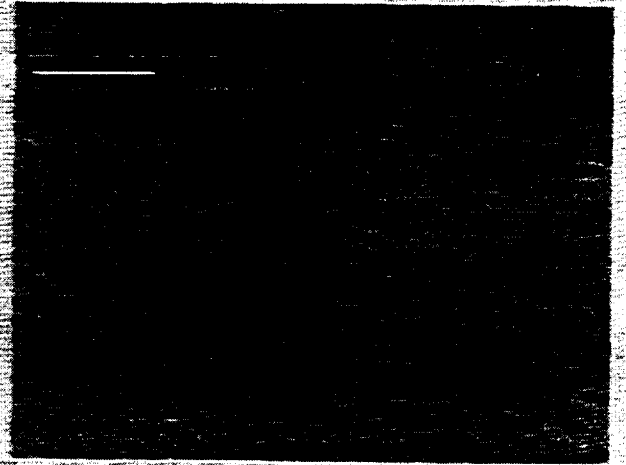


Figure 9. A 4-hour sample showing no particles

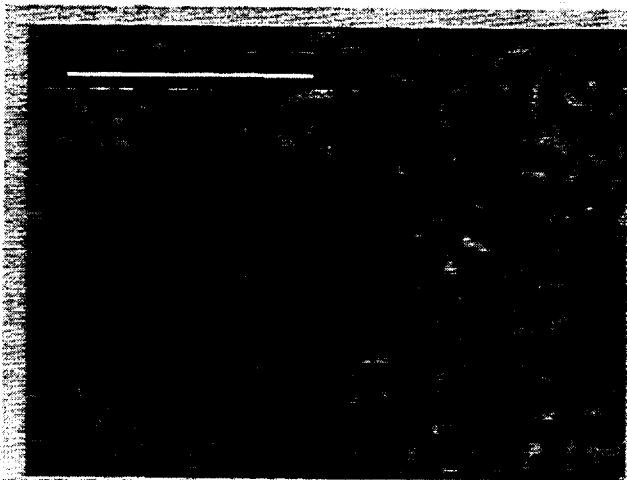


Figure 10. Wormlike formation of cross-linked polystyrene after 6 hours

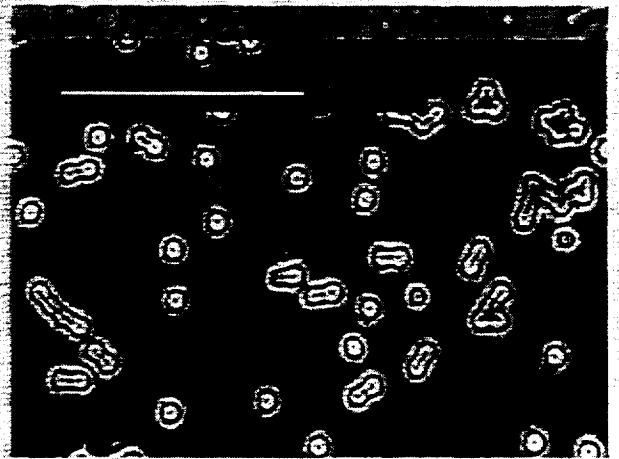
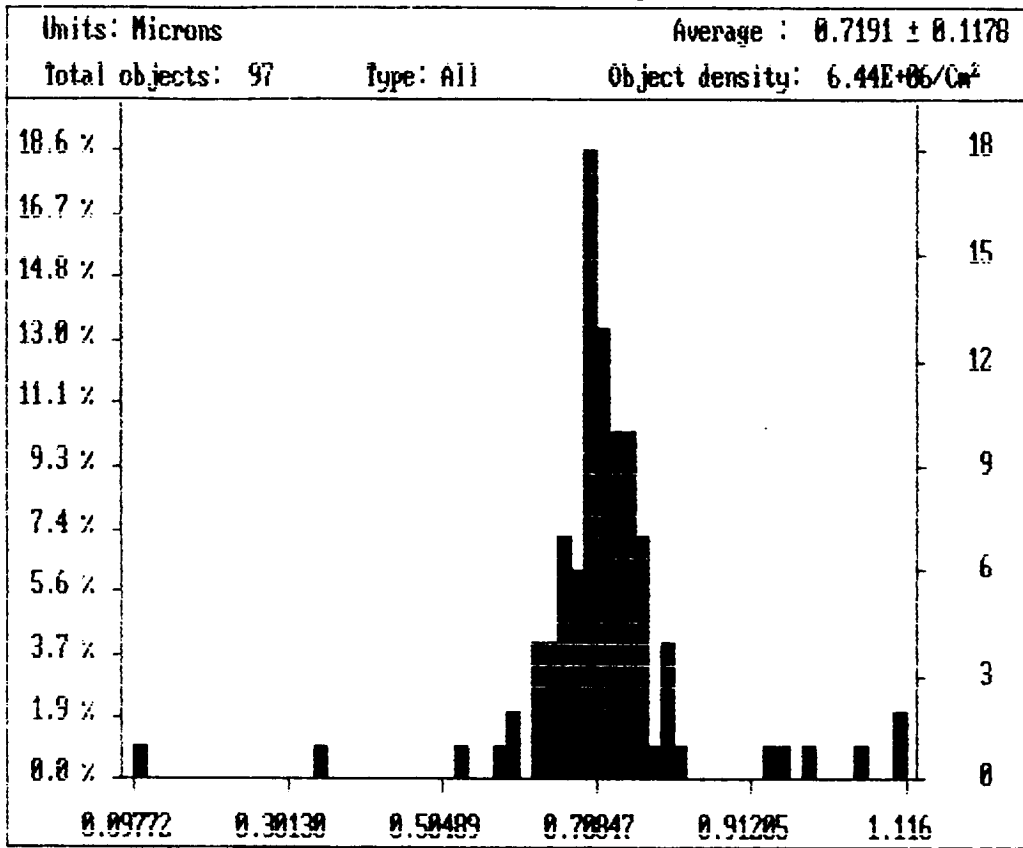


Figure 11. Monodisperse, spherical cross-linked polystyrene of size  $0.7 \mu$

Bar Histogram of Size (avg. ferets)



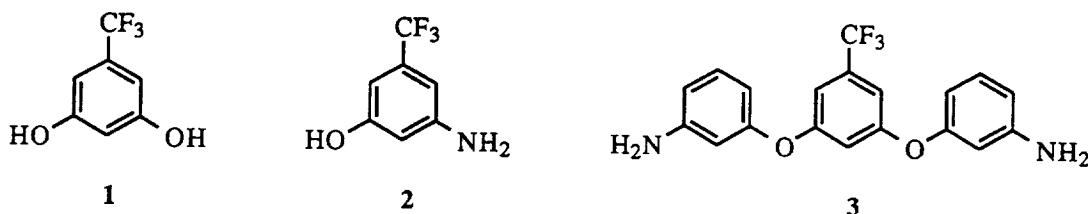
**Figure 12. Percent of various size beads produced, illustrating monodispersity of bead size 0.7  $\mu$  (on average)**

## NEW MONOMERS FOR HIGH PERFORMANCE POLYMERS

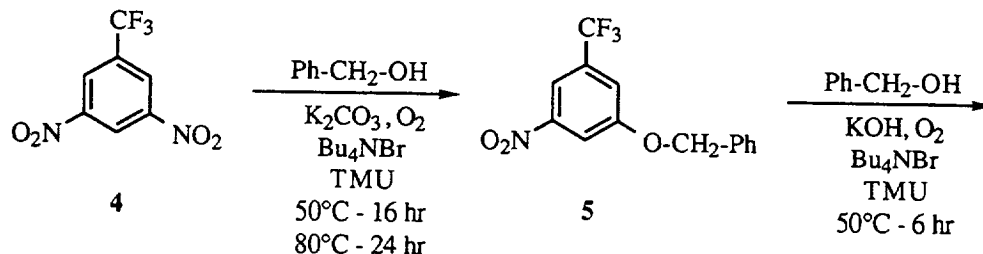
Roy F. Gratz, Professor  
 Department of Chemistry  
 Mary Washington College  
 Fredericksburg, VA 22401-5358

This laboratory has been concerned with the development of new polymeric materials with high thermo-oxidative stability for use in the aerospace and electronics industries. Currently, there is special emphasis on developing matrix resins and composites for the high speed civil transport (HSCT) program. This application requires polymers that have service lifetimes of 60,000 hr at 350°F (177°C) and that are readily processible into void-free composites, preferably by melt-flow or powder techniques that avoid the use of high boiling solvents. Recent work has focussed on copolymers which have thermally stable imide groups separated by flexible arylene ether linkages (1,2), some with trifluoromethyl groups attached to the aromatic rings (3). The presence of trifluoromethyl groups in monomers and polymers often improves their solubility and processibility.

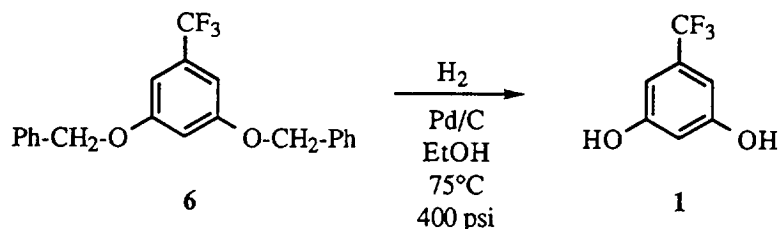
The goal of this research was to synthesize several new monomers containing pendant trifluoromethyl groups and to incorporate these monomers into new imide/arylene ether copolymers. Initially, work was begun on the synthesis of three target compounds. The first two, 3,5-dihydroxybenzotrifluoride, **1**, and 3-amino-5-hydroxybenzotrifluoride, **2**, are intermediates in the synthesis of more complex monomers. The third, 3,5-bis[3-amino-phenoxy]benzotrifluoride, **3**, is an interesting diamine that could be incorporated into a polyimide directly.



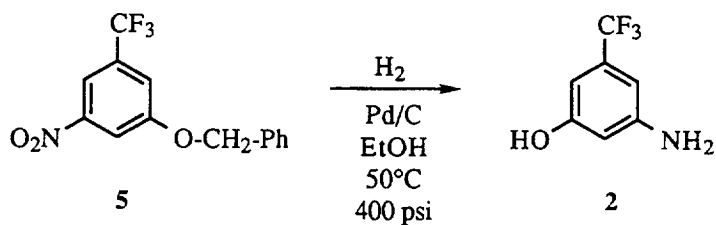
Two syntheses of 3,5-dihydroxybenzotrifluoride, **1**, are reported in the literature (4,5) beginning with commercially available 3,5-dinitrobenzotrifluoride, **4**. Both involve four steps, including reactions that tend to give low yields of the desired products. Based on a literature procedure (6), a new synthetic route to **1** has been devised involving stepwise replacement of the nitro groups of **4** with benzyloxy groups to give the benzyl ethers, **5** and **6**. The solvent for the reaction is tetramethylurea (TMU). Hydrogenolysis of **6** to give **1** completes the convenient three step synthesis.







Two methods for preparing 3-amino-5-hydroxybenzotrifluoride, 2, from 3,5-dinitrobenzotrifluoride, 4, have also been reported in the literature (4,7). Both methods involve three steps, including low yield reactions. By taking advantage of the fact that the benzyl ether of 3-benzyloxy-5-nitrobenzotrifluoride, 5, is cleaved at the same time the nitro group of 5 is being reduced by catalytic hydrogenation, a straightforward two step synthesis of 2 was accomplished.



An attempt to prepare 3,5-bis[3-aminophenoxy]benzotrifluoride, 3, in one step by substitution of both nitro groups of 3,5-dinitrobenzotrifluoride, 4, with the sodium salt of 3-aminophenol using the general procedure of reference (3) was unsuccessful. A two step procedure similar to that used to make 3,5-dibenzyloxybenzotrifluoride, 6, may produce the desired product and should be tried.

Future work in this area should include scaling up the syntheses of 1 and 2 and investigating the substitution of more common solvents for TMU. Standard techniques (1,2,3) could then be used to incorporate these structures into diamine and dianhydride monomers for the preparation of new polyimides.

- (1) Jensen, B. J.; Hergenrother, P. M.; Bass, R. G. *High Perform. Polym.*, **1991**, 3, 3.
- (2) Jensen, B. J.; Hergenrother, P. M.; Bass, R. G. *High Perform. Polym.*, **1991**, 3, 13.
- (3) Havens, S. J.; Hergenrother, P. M. *High Perform. Polym.*, **1993**, 5, 15.
- (4) Whalley, W. B. *J. Chem. Soc.*, **1949**, 3016.
- (5) Whalley, W. B. *J. Chem. Soc.*, **1951**, 3235.
- (6) Effenberger, F.; Koch, M.; Streicher, W. *Chem. Ber.*, **1991**, 124, 163.
- (7) Hauptschein, M.; Saggiomo, A. J.; Stokes, C. S. *J. Am. Chem. Soc.*, **1955**, 77, 2284.

## Neural Control of Magnetic Suspension Systems

Professor W. Steven Gray  
Department of Electrical and Computer Engineering  
Drexel University  
Philadelphia, Pennsylvania 19104

### Abstract

Magnetic suspension and balance systems have been investigated and utilized in a variety of application areas for more than fifty years (see [5] for a comprehensive bibliography). These applications include magnetic suspension wind tunnels for aerodynamic testing, magnetically levitated bearings and rotors for high performance machines, magnetic suspension and melting of metal ingots for die casting, and magnetically levitated vehicles. With recent advances in superconductor technology and sensor design, new applications areas are beginning to emerge in space science, and vacuum and surface physics.

Since magnetic suspension systems are naturally unstable in open loop, a reliable stabilizing controller is an integral part of their design. In applications where plant uncertainty is low, measurement quality is high, and linear control techniques are directly applicable, the design process is well defined and usually successful. For example, in traditional wind tunnel applications where a model containing a magnetic core is suspended in an equilibrium state for aerodynamic testing, the designer has significant knowledge and control of the environment in which the suspension system is to operate. The mass and geometry of the model are precisely known, instrumentation of the system is usually very complete, and environmental disturbances, for example to the optical position sensors, can be controlled to a large degree. Furthermore, for small and large air-gap systems where the model is to be suspended in quasi-steady-state about one or more operating points, a linear controller can normally be manually tuned to yield a functional design.

Linear control techniques are usually inadequate for a large air-gap system which is to be operated dynamically over a large neighborhood of an equilibrium point. This is primarily due to the strong nonlinearities associated with the plant. Furthermore, the stabilization and control of a nonlinear plant in the presence of uncertainty is largely an open problem at present. In the last few years, an alternative approach to nonlinear compensation has begun to emerge based on research concerning artificial neural networks in the context of controls. (For a good overview of the area see [3].) The basic idea behind this approach is that an array of simple nonlinear devices referred to as neurons can be interconnected via a *generic* learning algorithm, for example back-propagation, so as to emulate a dynamic or static nonlinear input-output map. The learned map can be either the input-output behavior of the plant or that of a nonlinear compensator which has been taught to deliver a desired closed-loop response. The primary advantages to such an approach are:

- Precise knowledge of the plant is not a prerequisite for training a neural network;
- Desired closed-loop performance can be directly specified and attained with arbitrary precision (though at the expense of increasing controller complexity);

- Compensator complexity for most real-time applications is manageable with existing digital technology (programmable VLSI neural network chips are just beginning to become available);
- On-line learning can be used to adjust for time variations in the plant's input-output behavior.

The purpose of this research program is to design, build and test (in cooperation with NASA personnel from the NASA Langley Research Center) neural controllers for two different small air-gap magnetic suspension systems. The general objective of the program is to study neural network architectures for the purpose of control in an experimental setting and to demonstrate the feasibility of the concept. The specific objectives of the research program are:

- To demonstrate through simulation and experimentation the feasibility of using neural controllers to stabilize a nonlinear magnetic suspension system;
- To investigate through simulation and experimentation the performance of neural controllers designs under various types of parametric and nonparametric uncertainty;
- To investigate through simulation and experimentation various types of neural architectures for real-time control with respect to performance and complexity;
- To benchmark in an experimental setting the performance of neural controllers against other types of existing linear and nonlinear compensator designs.

To date, the first one-dimensional, small air-gap magnetic suspension system has been built, tested and delivered to the NASA Langley Research Center. The device is currently being stabilized with a digital linear phase-lead controller. The neural controller hardware is under construction. Two different neural network paradigms are under consideration, one based on hidden layer feedforward networks trained via back propagation and one based on using Gaussian radial basis functions trained by analytical methods related to stability conditions. Some advanced nonlinear control algorithms using feedback linearization [1,2] and sliding mode control [4] are in simulation studies.

## References

- [1] B. Fernández, "Robust Feedback Linearization Through Sliding Mode Control," in *Proc. 29th IEEE CDC*, Honolulu, HI, pp. 3398-3399, 1990.
- [2] A. Isidori, *Nonlinear Control Systems*, 2<sup>nd</sup> Edition, Heidelberg: Springer-Verlag, 1989.
- [3] K. S. Narendra and K. Parthasarathy, "Identification and Control of Dynamical Systems Using Neural Networks," *IEEE Trans. Neural Networks*, vol. 1, pp. 4-27, 1990.
- [4] J. E. Slotine and W. Li, *Applied Nonlinear Control*, Englewood Cliffs: Prentice Hall, 1991.
- [5] M. H. Tuttle, D. L. Moore, and R. A. Kilgore, eds., *Magnetic Suspension and Balance Systems, A Comprehensive, Annotated Bibliography*, NASA Technical Memorandum 4318, NASA Langley Research Center, 1991.

## Locating tie-points on a grid

Jim Green  
Associate Professor  
Computer Science Dept.  
Moravian College  
Bethlehem, PA 18018

A robust software method is described for analyzing a digitized image of a calibration grid in order to determine the location of the intersections of its grid lines or tie-points.

Light sheets are used in wind tunnels to selectively illuminate seeded particle air flows in order to capture off surface phenomena. The sheets are photographed by cameras from points outside of the tunnel windstream and are distorted by the combined effects of camera perspective, lens aberrations, and the like. Calibration grids, photographed in the wind tunnel at the same position and plane as the light sheets, provide the basis for compensating for such distortion. [1]

The intersection points of the grid image are used as tie-points for a 2-D polynomial fit and subsequent warping of the light sheet images to remove the effects of the distortions. Previously, tie points have been measured manually, but, with over a few hundred points this is both a tedious and time consuming task.

A raw grid image is often characterized by variations in shading, extraneous off-grid imagery, and poor line definition as shown in figures 1 and 2. Image pattern recognition begins with image enhancement which, simply put, suppresses noise or unwanted features while enhancing desired features. The image with the target grid is first masked to remove any extraneous image objects that may impact subsequent processing by altering the masked area to levels as close to the background level as possible.

The image is then processed to eliminate regional shading variations while also reversing the image, if necessary, to make the grid lines get the numerically higher values. Regional variations are minimized by subtracting a heavily smoothed or averaged image, which has a predominance of low frequency components, from either the original or a slightly smoothed image. The result is an image which retains the local, high frequency, components, (i.e. the lines), while suppressing the shading variation.

Having prepared the image, the strategy at this point is to get an approximate idea where the grid lines fall and of their number.

Near the top of the masked area a sub area band of the image is delineated which is 32 pixels high and equal in width to the grid image. Each 32 pixel column of this sub area is summed to form a horizontal summation array. In those parts of this array that

correspond to places where vertical lines exist the array values are sharply higher. The array is relatively insensitive to horizontal lines. The array values are truncated to remove background values.

The vertical lines of the grid in the sub area corresponding to the summation array are located by locating the peak positions in the array as shown in figure 3.

A similar process is used along the left-hand side of the grid to determine the position of the horizontal lines. Once each line has been located at some point along its length, a basis exists for estimating the position of each line intersection or tie point. The task becomes one of more precisely locating the lines at those points where they intersect. Figure 4.

No allowance has been made thus far for the angles or distortions in the line images, therefore, estimates of horizontal and vertical points are more accurate near where they were collected and less so with distance from the measurement locations. The measurements may be improved by going to each estimated position of a tie point and doing a more direct measurement in that locale.

Local searches for the actual intersection points are conducted within small windows about each estimated intersection position. As each position is accurately identified the difference or error between the estimated and actual position is used to improve the estimate of the next subsequent position. This error correction technique makes the location of even very distorted grid tie-points possible.

In the local search the horizontal and vertical lines are, again, dealt with separately. On each axis within the window the pixel values are again summed along the axis of interest. These values are again saved in an array but since only one center value is desired a weighted mean value of the array is used as the center position.

It is possible that at certain points of the original image the line definition is so poor that an accurate measure of the position of some tie points is doubtful. In such instances position information of neighboring tie points can be used to augment or even replace a poor measure. This interpolation can be done using a least squares fit of the data. Caution must be exercised, however because, except over short spans, the image positions of the tie points cannot be assumed to be strictly linear.

Once the tie-point positions have been determined they are used, along with ideal values, to calculate 2-D polynomial coefficients of the desired order to warp the image into the form of the ideal. See figures 5 and 6.

1. Stacy, Kathryn; Severance, Kurt; and Childers, Brooks A.: Computer-Aided Light Sheet Flow Visualization, AIAA 24th Fluid Dynamics Conference (Orlando, Florida), July 6, 1993.

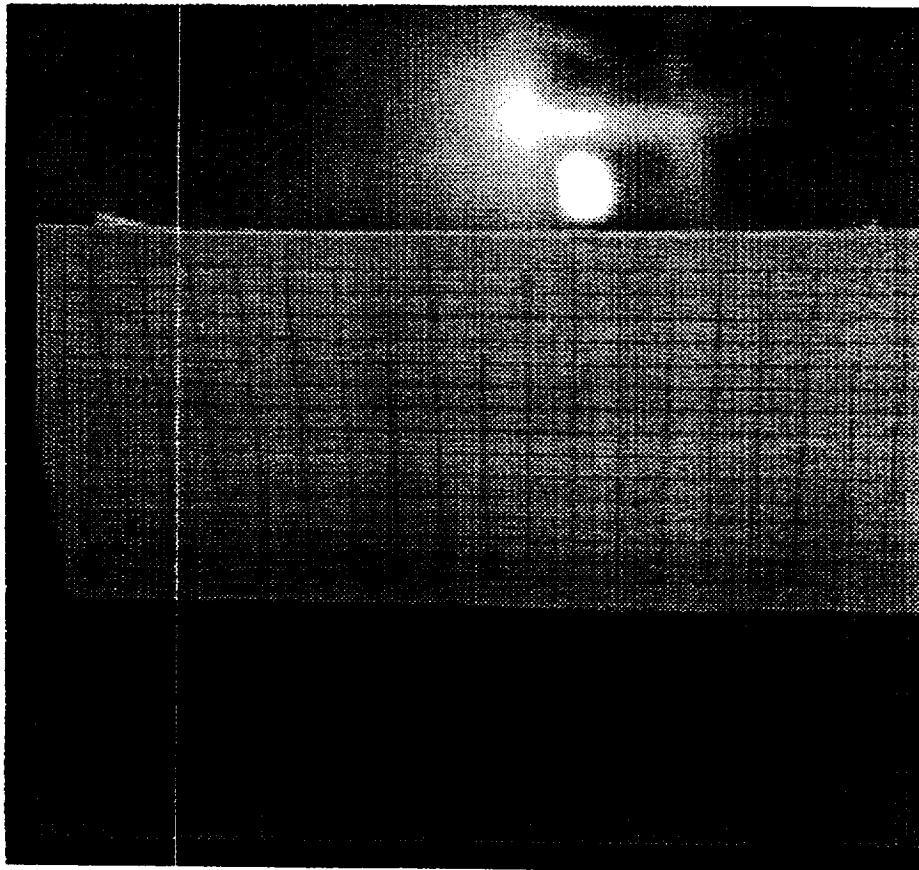


Figure 1. Calibration grid with distortion.

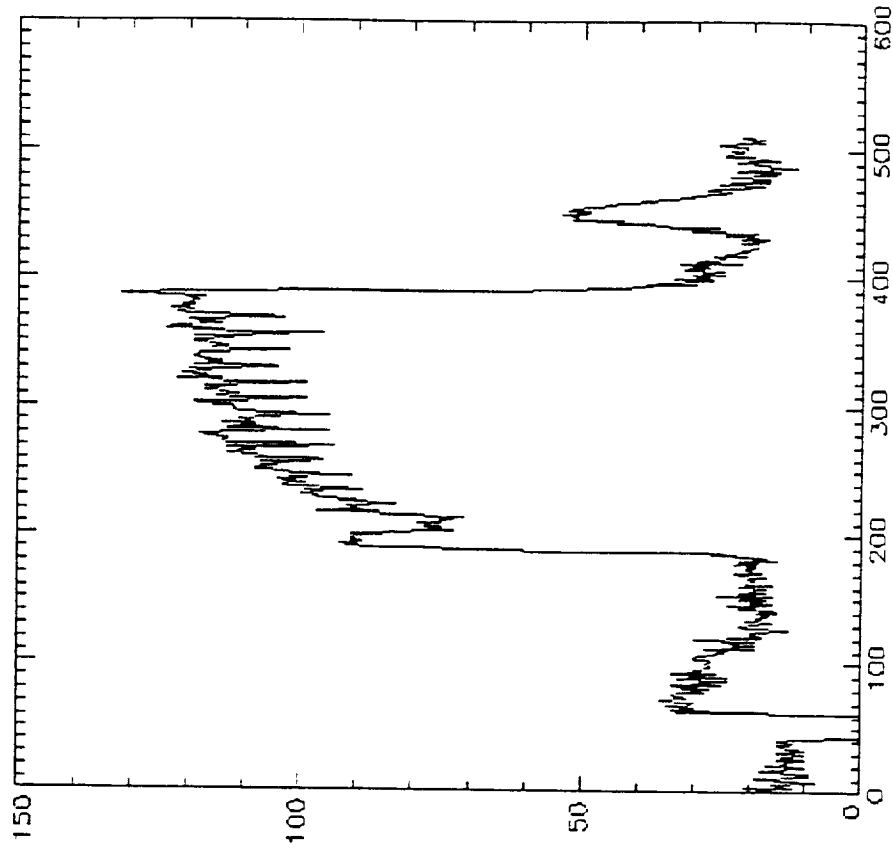


Figure 2. Scan line detail along white line shown in figure 1.

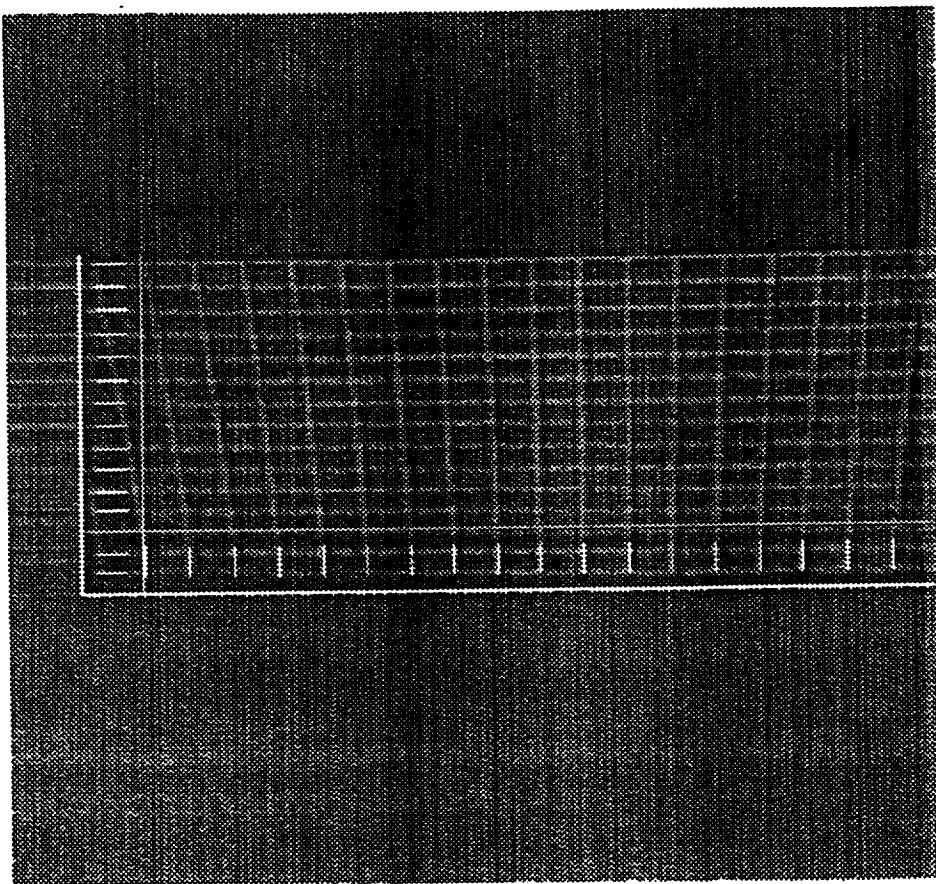


Figure 4. Overlay of enhanced grid line image with line markers in the regions where they are measured.

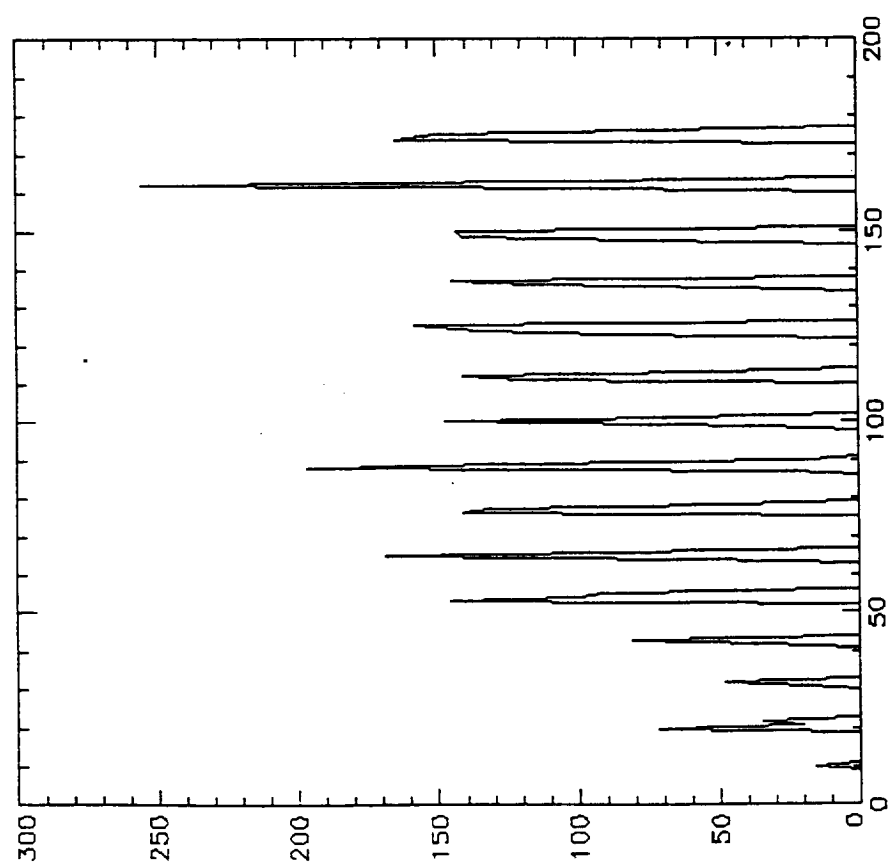


Figure 3. Horizontal summation array. Peaks correspond to vertical lines.

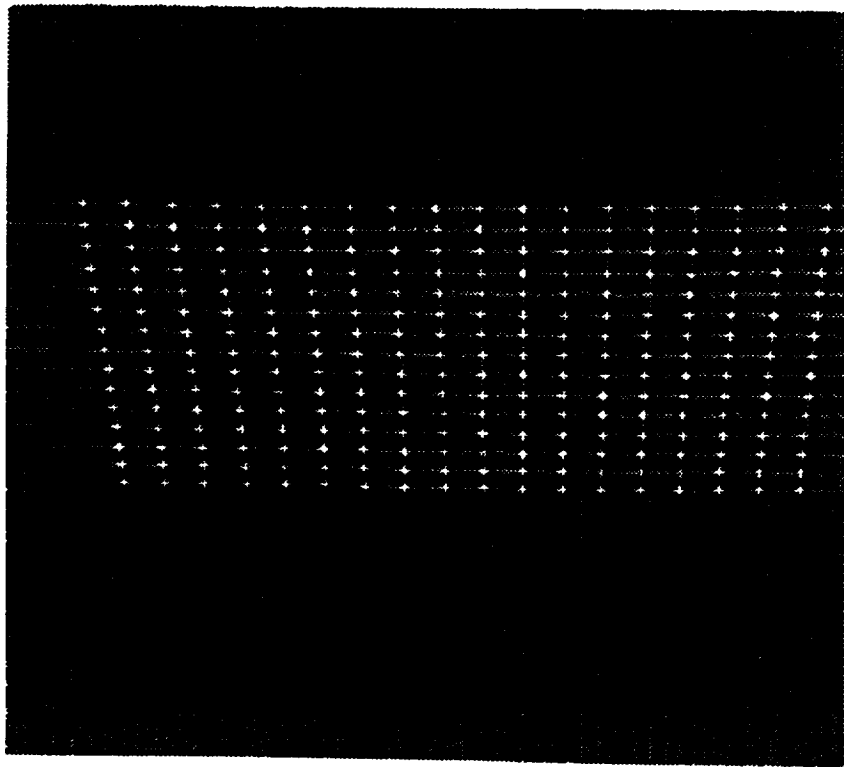


Figure 5. Enhanced image overlain with markers at individual tie-points.

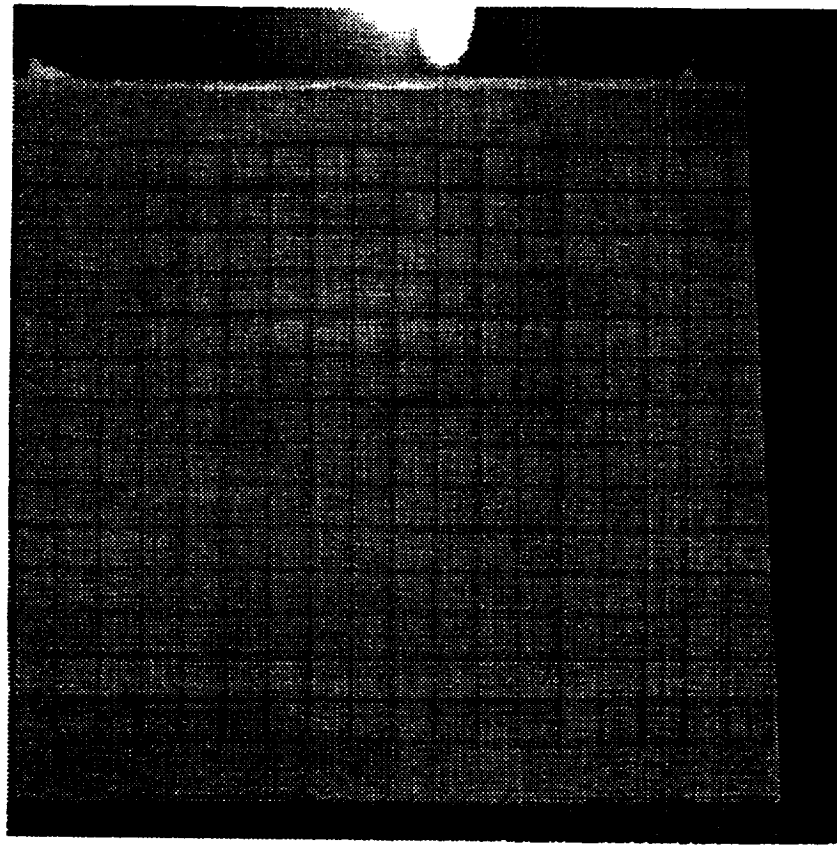


Figure 6. Calibration grid warped to remove distortion.



# Spacecraft Optical Disk Recorder Memory Buffer Control

by

Robert F. Hodson

Department of Physics & Computer Science  
Christopher Newport University  
Newport News, VA 23606

## Abstract

This paper discusses the research completed under the NASA-ASEE summer faculty fellowship program. The project involves development of an Application Specific Integrated Circuit (ASIC) to be used as a Memory Buffer Controller (MBC) in the Spacecraft Optical Disk System (SODR). The SODR system has demanding capacity and data rate specifications requiring specialized electronics to meet processing demands. The system is being designed to support Gigabit transfer rates with Terabit storage capability. The complete SODR system is design to exceed the capability of all existing mass storage systems today. The ASIC development for SODR consist of developing a 144 pin CMOS device to perform format conversion and data buffering. The final simulations of the MBC were completed during this summer's NASA-ASEE fellowship along with design preparations for fabrication to be performed by an ASIC manufacturer.

## I. Project Goals

The goal of this project is to develop an Application Specific Integrated Circuit (ASIC) for use in the control electronics of the Spacecraft Optical Disk Recorder (SODR). Specifically, this project is to design an extendable memory buffer controller ASIC for rate matching between a system Input/Output port and the SODR's device interface.

The aforementioned goal can be partitioned into the following sub-goals:

- 1) Completion of ASIC design and simulation,
- 2) ASIC Fabrication (@ ASIC manufacturer),
- 3) ASIC Testing (NASA/LaRC, CNU).

## II. Project Description

My research activities during my NASA-ASEE fellowship have been part of the SODR project in the Flight Electronics Division. The SODR project will develop a space qualified optical disk storage system for mass storage and high data rate applications. The system architecture calls for a reconfigurable and extendable optical disk storage system. A multiport system will support terabit capacity and gigabit transfer rates. The disk drive (two devices) requirements call for 10 Gbytes of disk capacity and sustained data rates of 300 Mbps. The high level SODR system architecture is shown in Figure 1.

The specific system being developed in this project is the Memory Buffer Controller (MBC). The function of the MBC is to interface a system I/O port to a SODR device (note each optical disk drive is two devices). Since the instantaneous data rates of the I/O port and the SODR device may vary, a buffer memory is required for data rate matching between these two interfaces.

The current MBC system design calls for an 8-bit data path which is cascadable to support a 32-bit HPPI (High Performance Parallel Interface) data I/O port. The HPPI data port (or multiple HPPI data ports) will be the data I/O path for the SODR system. The MCB's SODR device interface is currently designed to support SCSI II protocol (16-bit, fast). Both interfaces selected have ANSI standards and support the high data rates specified by the SODR system requirements.

Functionally, the MBC ASIC decomposes into the following sections:

- 1) The HPPI source and destination interface,
- 2) The SCSI II interface to the optical disk recorder,
- 3) The Group Controller interface for MBC control and testing,
- 4) The memory buffer interface,
- 5) The MBC system controller.

Figure 2 shows the MBC ASIC with all the major interfaces in a 32-bit I/O port configuration.

### **III. NASA-ASEE Summer Research Activities**

This summer activities are part of my second NASA-ASEE fellowship. The research started last summer with activities which included:

- 1) System architecture development,
- 2) Interface definitions,
- 3) Memory subsystem design & simulation,
- 4) Control algorithm development.

This summer provided the opportunity to simulate the system design. Digital simulations of the MBC system were performed using the Cadence Design Tools and the Verilog-XL simulator. Extensive tests were run to verify correct operation under a variety of conditions. Functional test were performed under minimum/typical/maximum timing conditions. Test vectors for manufacturer testing were also generated. Critical timing issues were resolved and preparation for manufacturer's sign-off were made. In the near future the MBC ASIC will be sent to US2 for fabrication. The final product will be a 144 pin custom CMOS ASIC with a 50 MHz maximum clock frequency.

Post layout simulations and post fabrication testing still remain to be done and are planned for this Fall. This summer's NASA-ASEE fellowship has grown into additional grant work with NASA and has furthered the relationship between NASA and Christopher Newport University.

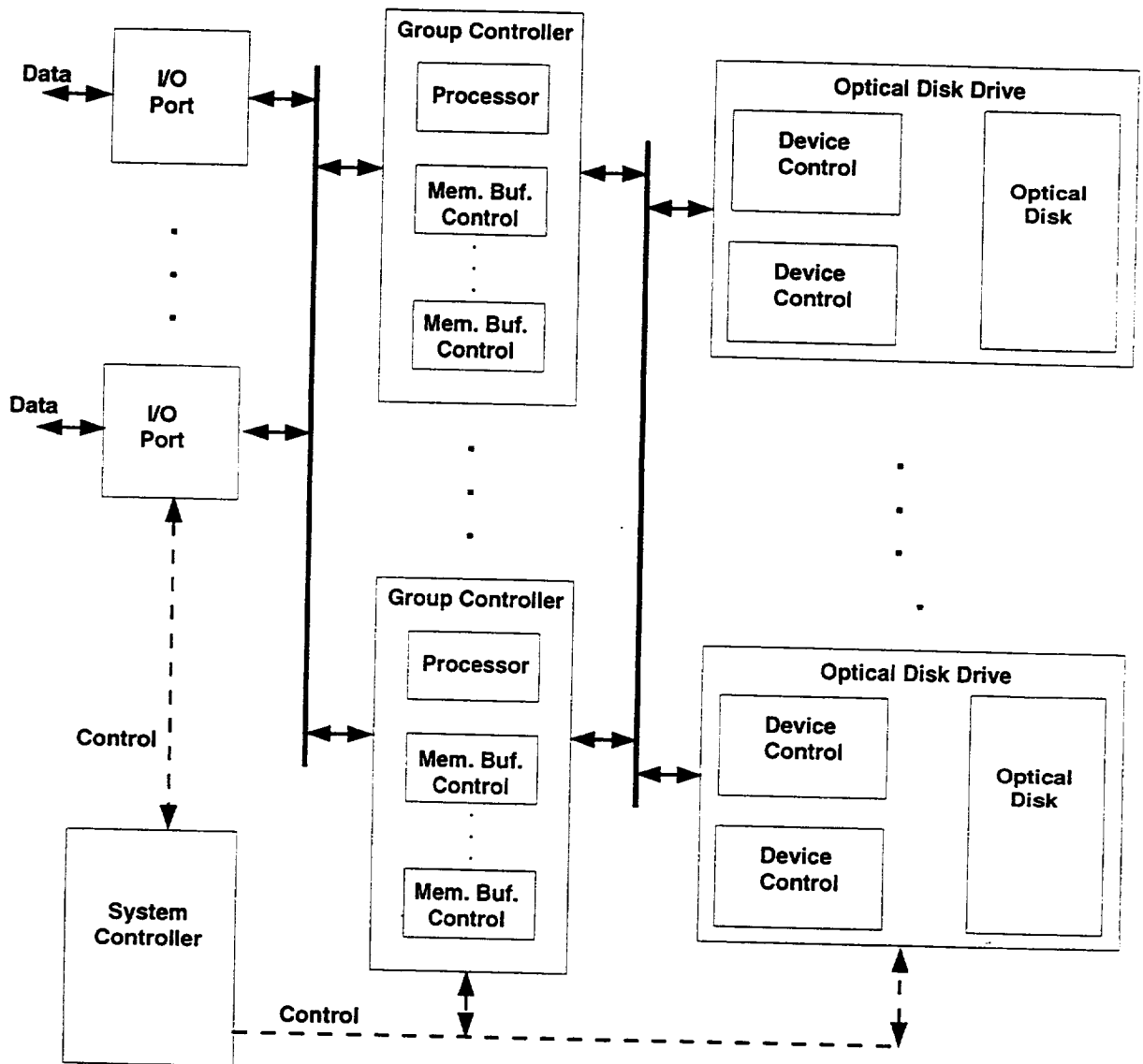
The MBC ASIC is the first custom integrated circuit being developed by the Flight Electronics Division. Therefore almost as important as the device itself, is the process used to design it. Many lessons were learned in the development process which will make future ASIC development much easier. Problems in the design flow have been identified and are being addressed for future projects. Issues of testability, fault coverage and configuration management have been raised by the development of the MBC ASIC. Future projects are sure to benefit from the knowledge gained through the design of this system.

#### **IV. ASEE Related Issues**

In addition to my research activities, I had the opportunity to use a powerful set of design tools for ASIC development. The use of these tools will extend to the classroom for both undergraduate and graduate courses. Contacts made during my NASA-ASEE fellowship have, in-part, made it possible to bring these tools into a university environment.

#### **V. Acknowledgments**

Special thanks to Tom Shull (my associate), Steve Jurczyk, and other members of the SODR team for their help and encouragement.



**Figure 1. SODR System Architecture**

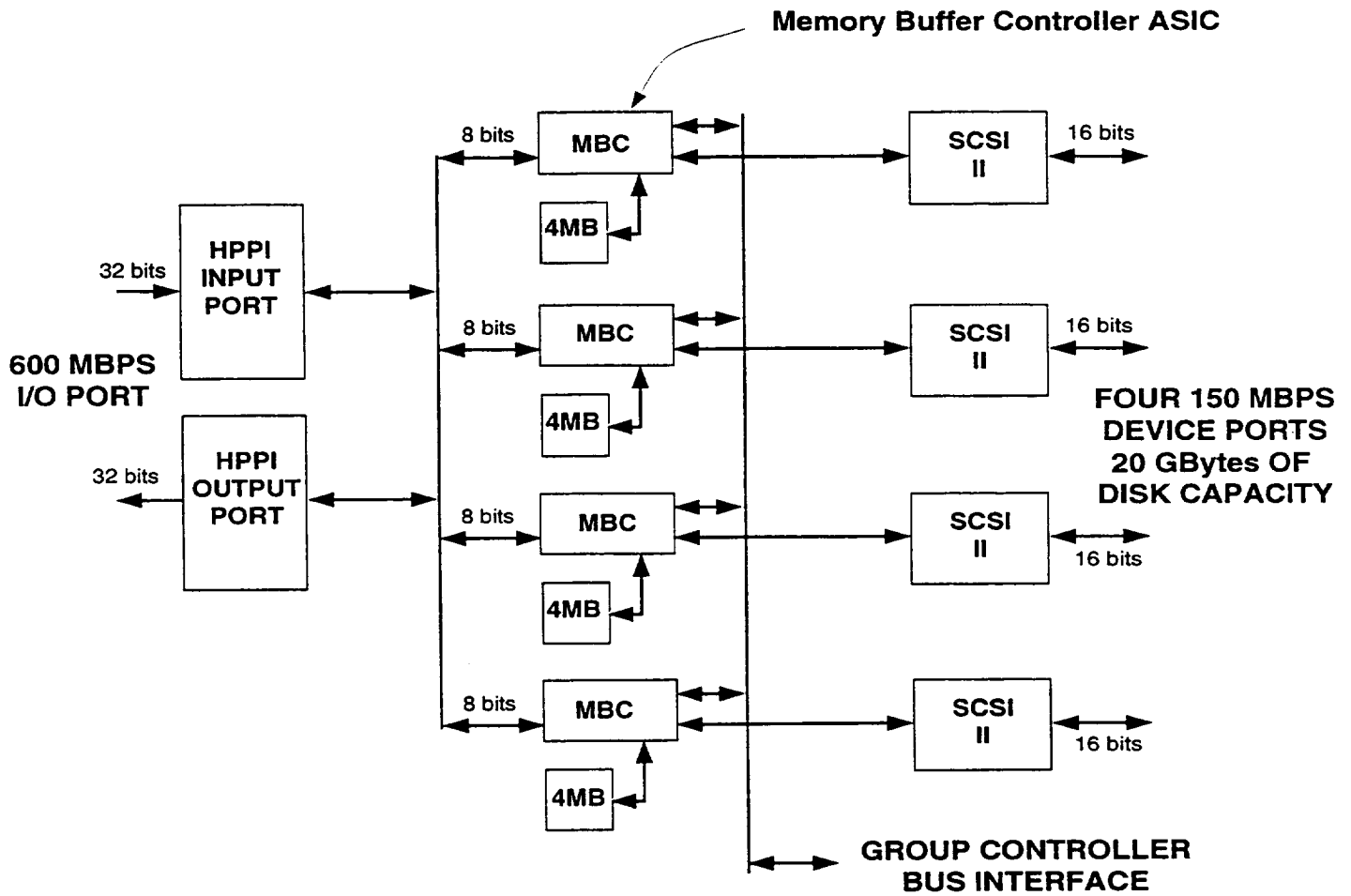


Figure 2. MBC with 32-bit HPPI and 16-bit SCSI

**SYSTEM IDENTIFICATION OF THE LARGE-ANGLE  
MAGNETIC SUSPENSION TEST FACILITY (LAMSTF)**

by

Professor Jen-Kuang Huang  
Department of Mechanical Engineering  
Old Dominion University  
Norfolk, Virginia 23529-0247

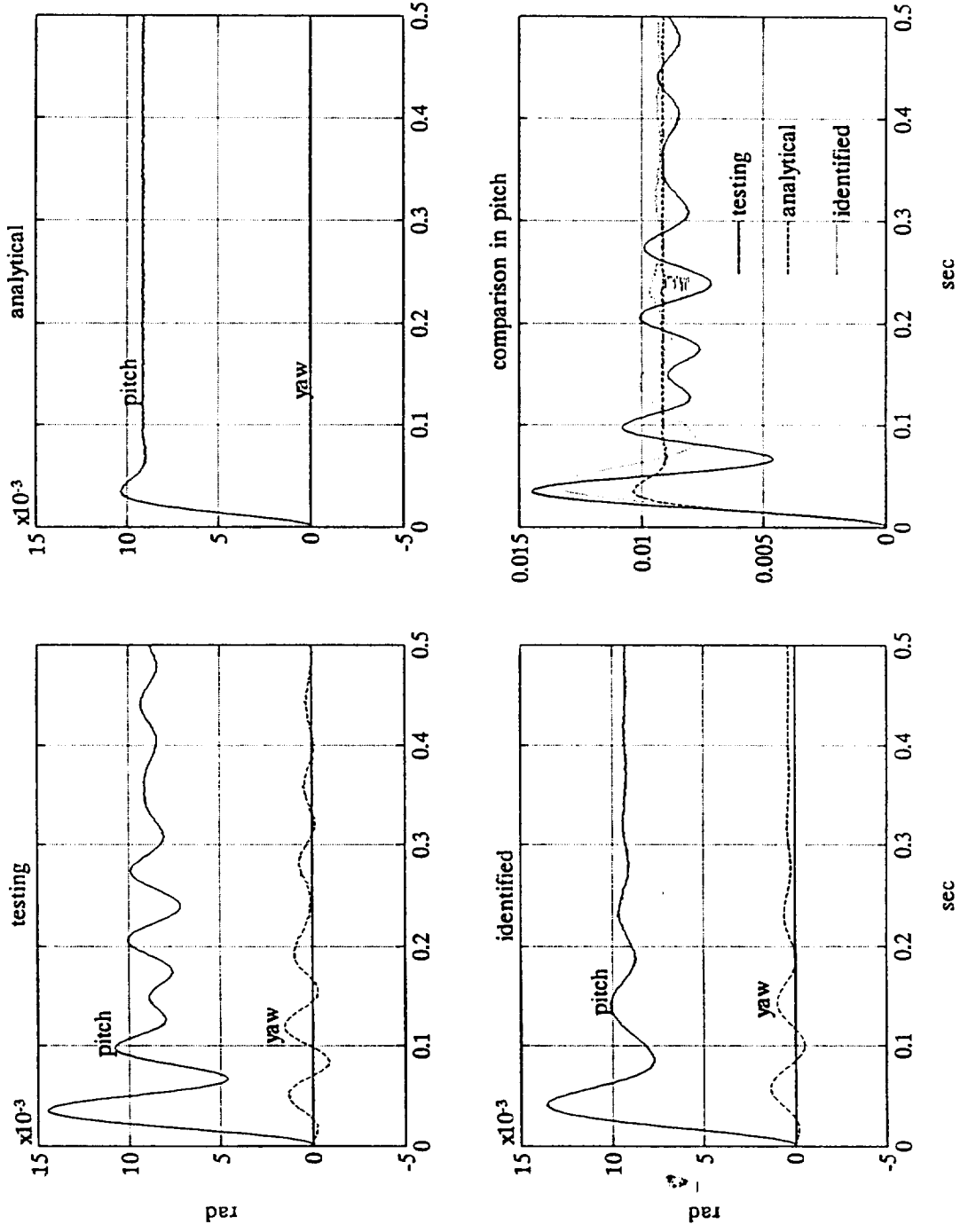
**Abstract**

The Large-Angle Magnetic Suspension Test Facility (LAMSTF), a laboratory-scale research project to demonstrate the magnetic suspension of objects over wide ranges of attitudes, has been developed. This system represents a scaled model of a planned Large-Gap Magnetic Suspension System (LGMSS). The LAMSTF system consists of a planar array of five copper electromagnets which actively suspend a small cylindrical permanent magnet. The cylinder is a rigid body and can be controlled to move in five independent degrees of freedom. Five position variables are sensed indirectly by using infra-red light-emitting diodes and light-receiving phototransistors. The motion of the suspended cylinder is in general nonlinear and hence only the linear, time-invariant perturbed motion about an equilibrium state is considered.

One of the main challenges in this project is the control of the suspended element over a wide range of orientations. An accurate dynamic model plays an essential role in controller design. The analytical model of the LAMSTF system includes highly unstable real poles (about 10 Hz) and low-frequency flexible modes (about 0.16 Hz). Projection filters are proposed to identify the state space model from closed-loop test data in time domain. A canonical transformation matrix is also derived to transform the identified state space model into the physical coordinate.

The LAMSTF system is stabilized by using a linear quadratic regulator (LQR) feedback controller. The rate information is obtained by calculating the back difference of the sensed position signals. The reference inputs contain five uncorrelated random signals. The control input and the system response are recorded as input/output data to identify the system directly from the projection filters. The sampling time is 4 ms and the data length is 24 sec. Preliminary results demonstrate that the identified model is fairly accurate in predicting the step responses for different controllers while the analytical model has a deficiency in the pitch axis (see the following figure).

# Comparison (Step Response with Dynamic Controller)



## Kinetic Parameters from Thermogravimetric Analysis

Richard L. Kiefer  
Department of Chemistry  
College of William and Mary  
Williamsburg, VA 23187

**Introduction**

High performance polymeric materials are finding increased use in aerospace applications. Proposed high speed aircraft will require materials to withstand high temperatures in an oxidative atmosphere for long periods of time. It is essential that accurate estimates be made of the performance of these materials at the given conditions of temperature and time. Temperatures of 350° F (177° C) and times of 60,000 to 100,000 hours are anticipated. In order to survey a large number of high performance polymeric materials on a reasonable time scale, some form of accelerated testing must be performed.

A knowledge of the rate of a process can be used to predict the lifetime of that process. Thermogravimetric analysis (TGA) has frequently been used to determine kinetic information for degradation reactions in polymeric materials. Flynn and Wall studied a number of methods for using TGA experiments to determine kinetic information in polymer reactions.<sup>1</sup> Figure 1 shows a typical TGA graph with the mass and the derivative plotted against the temperature. Kinetic parameters, such as the apparent activation energy and the frequency factor, can be determined in such experiments. Recently, researchers at the McDonnell Douglas Research Laboratory suggested that a graph of the logarithm of the frequency factor against the apparent activation energy can be used to predict long-term thermo-oxidative stability for polymeric materials<sup>2</sup>. Such a graph has been called a kinetic map. In this study, thermogravimetric analyses were performed in air to study the thermo-oxidative degradation of several high performance polymers and to plot their kinetic parameters on a kinetic map.

**Kinetic Map**

The kinetic map, shown in Figure 2, assumes that the reactions involved follow first order kinetics and the Arrhenius reaction model. The solid lines, called aging limits, serve as benchmarks against which the experimental values are compared. For a first order reaction,

$$\frac{dV(t)}{dt} = -kV(t)$$

where  $V(t)$  is the concentration of the reacting specie at time,  $t$ , and  $k$  is the rate



$$k_o = \frac{\ln\left(\frac{V}{V_o}\right)}{-t} e^{\frac{E}{RT}}$$

where  $V_o$  is the initial concentration. Now, one can pick a specific reaction temperature,  $T$ , a fraction of conversion or degradation of the polymer, and the time,  $t$ , required to reach that conversion. The upper line in Figure 2 assumes a fractional conversion of 0.01, i.e.,  $V/V_o = 0.99$ , a temperature,  $T$ , of 450 K (350° F), and a time,  $t$ , of 60,000 hours. Values of  $k_o$  are calculated for several reasonable values of  $E$ , and the line is drawn. The lower line assumes room temperature with the other parameters the same.

### Experimental

The kinetic parameters were determined by running dynamic TGA experiments for each material studied at 6 different heating rates, 1, 2, 4, 8, 10, and 15° C/min. It has been shown that the derivative of the mass loss curve as a function of temperature during a TGA experiment with a linear heating rate is<sup>3</sup>

$$\frac{dV}{dT} = \frac{k_o V_o}{m} \exp\left[-\frac{E}{RT} - \frac{k_o RT^2}{mE} e^{-\frac{E}{RT}}\right]$$

where  $m$  is the linear heating rate, and the other quantities are defined above. The derivative reaches a maximum during the rapid degradation of the material at high temperature, as seen in Figure 1. The temperature at which this occurs,  $T_{max}$ , can be determined by setting the second derivative to zero, i.e.,  $d^2V/dT^2 = 0$ . Solving for  $k_o$  at this point gives

$$k_o = \frac{mE}{RT^2} e^{\frac{E}{RT}}$$

Plotting  $\ln(m/T_{max}^2)$  against  $1/T_{max}$  yields a straight line with slope =  $-E/R$ , and intercept =  $\ln(k_o R/E)$ . Thus, both kinetic parameters are determined for such a graph.

The TGA experiments were performed on a Seiko TG/DTA 200 thermogravimetric analyzer. Several materials were analyzed: LaRC-IA, a polyimide developed in the Polymeric Materials Branch at the Langley Research Center; PETI, the same polyimide with a phenylethynl endcap and a composite, IM7/K3B, made with IM7 carbon fibers and K3B commercial thermoplastic. Two forms of PETI were analyzed, they differed in the number of mass units of oligomer between endcaps. One had 9000, the other had 6000, and they are specified below as PETI-9 and PETI-6. The LaRC-IA and PETI samples were obtained as powders and were used as received. The composite was ground to a powder fine enough to pass through an 80 mesh screen. Dry ice was ground with the composite to prevent heat buildup

during the grinding process. The powder was dried overnight in a vacuum oven.

Data from the TG analyzer were transferred to a personal computer for smoothing and analysis. Values of  $T_{\max}$  for a specific sample were determined for each heating rate. The slope of the line on the  $\ln(\text{heat rate}/T_{\max}^2)$  vs  $1/T_{\max}$  plot was determined by a linear least squares analysis. The results are tabulated in Table 1, and plotted on Figure 2.

In theory, materials whose kinetic parameters fall on or to the right of the upper aging line will suffer no more than 1% degradation during 60,000 hours at 350° F. On this basis, the composite, IM7/K3B, is apparently the best of the materials tested. However, it is the only composite material used. A better comparison with the other materials would be with the pure K3B resin. At best, kinetic mapping can only serve as a preliminary screening for materials. Aging tests must still be done though the kinetic map could eliminate some materials before such tests.

## References

1. Flynn, J. H. and Wall, L. A., "General Treatment of the Thermogravimetry of Polymers", *J. Res. NBS-A*, **70A**, 487 (1966).
2. Michael A. Grayson, McDonnell Douglas Research Laboratory, St Louis, MO, private communication.
3. K. H. van Heek, H. Juntgen, and W. Peters, *Berichte der Bunsengesellschaft fur Physikalische Chemie*, **71(1)**, 113, (1967).

**Table 1**

### Kinetic Parameters of Several Materials

<u>Material</u>	<u>E (kJ/mol)</u>	<u><math>k_0</math> (min<sup>-1</sup>)</u>	<u>log <math>k_0</math></u>
LaRC-IA	131	$5.84 \times 10^6$	6.77
PETI-9	106	$1.66 \times 10^5$	5.22
PETI-6	134	$6.86 \times 10^6$	6.83
IM7/K3B	165	$2.84 \times 10^9$	9.45

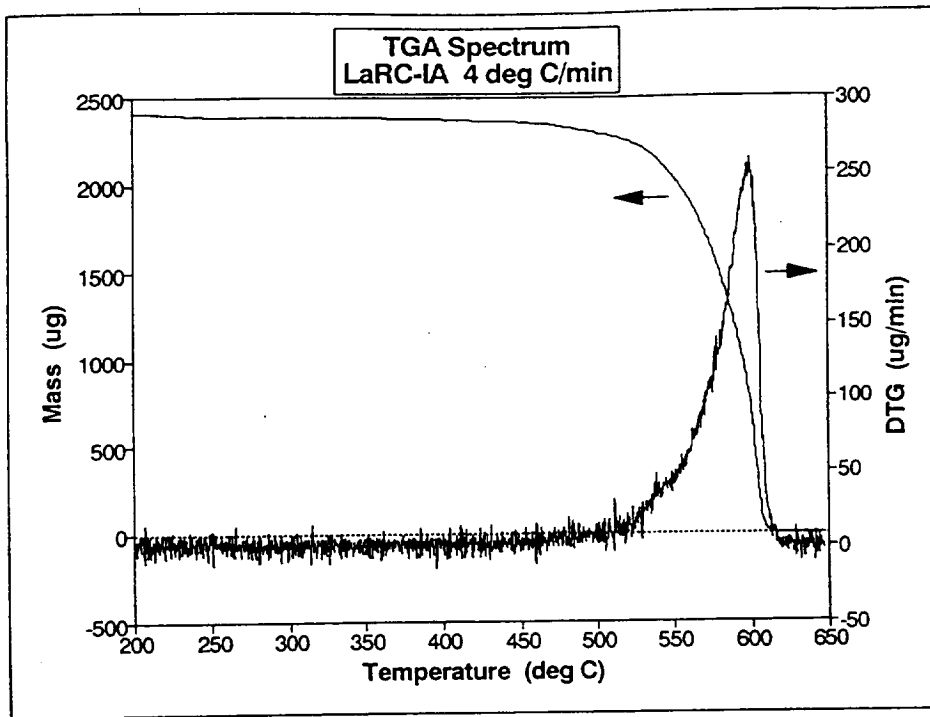


Figure 1. A TGA spectrum for LaRC-IA powder at a heating rate of 4° C/min.

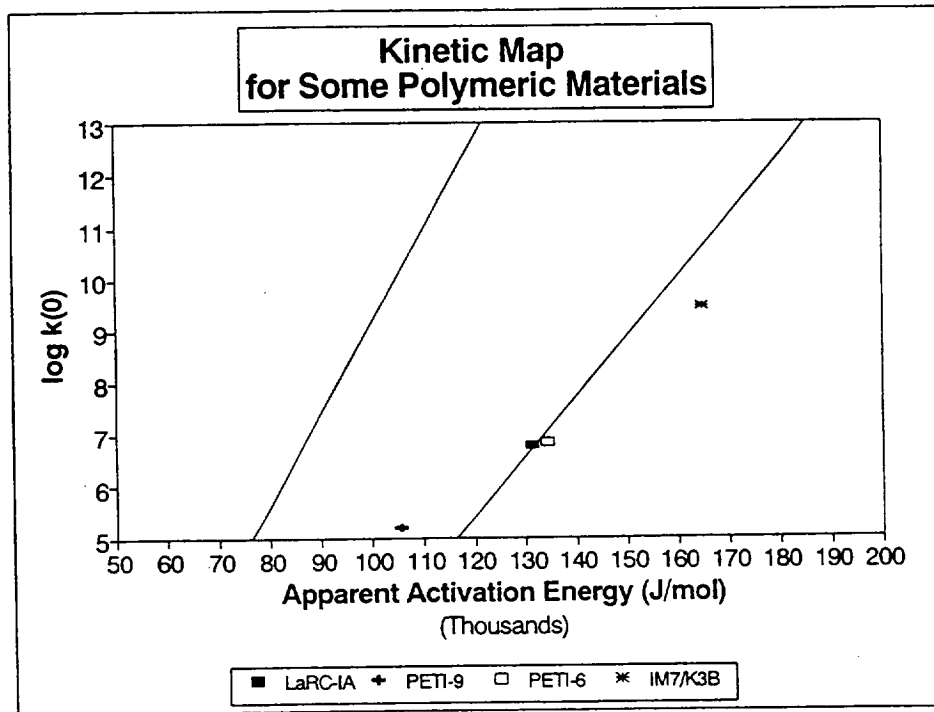


Figure 2. A kinetic map for several polymeric materials.

## THE MOLECULAR MATCHING PROBLEM

by

Professor Rex K. Kincaid  
 Department of Mathematics  
 The College of William and Mary  
 Williamsburg, VA 23187

## Abstract

Molecular chemistry contains many difficult optimization problems that have begun to attract the attention of optimizers in the Operations Research community. Problems including protein folding, molecular conformation, molecular similarity, and molecular matching have been addressed. Minimum energy conformations for simple molecular structures such as water clusters, Lennard-Jones microclusters, and short polypeptides have dominated the literature to date. However, a variety of interesting problems exist and we focus here on a molecular structure matching (MSM) problem.

Consider two molecular structures,  $A$  and  $B$ , of similar size. We are asked to determine how similar the two structures are. One of the molecular structures, say  $A$ , and its inter-atomic distance matrix  $D_A$  is known a priori. The only information known for the second structure,  $B$ , is its inter-atomic distance matrix  $D_B$ . If the two molecular structures have the same number of atoms then the objective is to find a permutation (represented by a permutation matrix  $P$ ) of the rows and columns of  $D_B$ , so that the absolute value of the entry-wise matrix difference,  $D_A - PD_B P^T$ , is as small as possible. In the case when there exists a permutation yielding a difference of zero, then the two molecules are identical (up to rotations and translations). The MSM problem was first studied by Barakat and Dean (1990a,b).

In the ensuing presentation we will focus solely on the structural matching problem when the two molecular structures have the same number of atoms. Similar techniques can be applied to the case when the molecular structures are unequal in size. In particular, we will study randomly generated structures generated in the unit cube and two DHFR protein structures (*L. casei* and *E. coli*) obtained from the Brookhaven protein data bank. First, we formulate the MSM problem as a 0/1 nonlinear integer programming problem and discuss the performance of a linearization technique due to Oral and Kettani (1992). Next, a tabu search heuristic is described and its performance summarized.

A 0/1 nonlinear integer program can be constructed for the MSM problem. The 0/1 decision variables  $p_{ij}$  are the entries in the permutation matrix  $P$ . In addition to the 0/1 restriction, each row and column of  $P$  must have exactly one entry with a value of 1. This is reflected in the following constraints.

$$\sum_{i=1}^n p_{ij} = 1 \text{ for all } j = 1..n \text{ and } \sum_{j=1}^n p_{ij} = 1 \text{ for all } i = 1..n. \quad (1)$$

The entries in the matrix  $D_A$  and  $D_B$  represent the euclidean distances between the atoms (or points in  $\mathcal{R}^3$ ). As a result the distance matrices are symmetric with zero entries on the main diagonal. Two objective functions are considered;

$$(2) \min \sum_{i=1}^{n-1} \sum_{j=i+1}^n |d_{ij}^A - \sum_{k=1}^n \sum_{l=1}^n p_{ik} d_{kl}^B p_{jl}| \text{ and } (3) \min \sum_{i=1}^{n-1} \sum_{j=i+1}^n (d_{ij}^A - \sum_{k=1}^n \sum_{l=1}^n p_{ik} d_{kl}^B p_{jl})^2.$$

Objective function (2) appears to be simpler, in that, when expanded, the resulting polynomial is of degree two. However, the absolute value terms are difficult to implement in most standard optimization packages. Objective function (3), when expanded, results in a fourth order polynomial. This polynomial can be dramatically simplified by imposing the 0/1 restrictions and the constraints (1). In fact, all third and fourth order terms vanish and we are left with a 2nd degree polynomial. Consequently we use (3) so that we can avoid the absolute value terms of (2). The resulting 0/1 quadratic integer program (QIP) will have  $n^2$  decision variables and  $2n$  linear constraints.

One approach to solve this 0/1 QIP (or at least provide an upper bound on the optimal objective function for the heuristic search) is to first linearize the quadratic objective function so that a 0/1 integer linear

program (ILP) results. By doing this we now have a variety of commercially available linear programming (LP) and branch and bound codes at our disposal. The LP codes can solve the 0/1 ILP if we relax the 0/1 restrictions. That is, if we replace  $p_{ij} = 0, 1$  with  $p_{ij} \geq 0$  and  $p_{ij} \leq 1$ . The hope is that the optimal solution to the LP relaxation will have many of the  $p_{ij}$  close to 0 or 1 and that this solution can be used as a *hot start* for the heuristic search procedures. If this does not happen the branch and bound codes will provide feasible solutions (and perhaps optimal solutions), but at a much greater computational effort.

Several linearizations procedures exist for quadratic 0/1 integer program with linear constraints. We have chosen the most compact formulation available (due to Oral and Kettani 1992) since we hope to be able to solve relatively large problems. Their linearization of our problem results in  $2n^2$  decision variables and  $n^2 + 2n$  regular constraints plus  $n^2$  upper bound constraints of the form  $p_{ij} \leq 1$  (non-negativity of the decision variables is assumed by all commercial codes).

The above techniques were tested on  $n = 10$  and  $n = 20$  size problems. The second being an 800 variable 440 constraint (with 400 upper bounds) size linear program. Both of the LP relaxations yielded optimal solutions with  $p_{ij}$  near  $1/n$  for nearly all  $i$  and  $j$ . That is, almost none of the decision variables were close to 0 or 1. Consequently, this method did not yield an effective way to generate starting solutions for the heuristic algorithm. When  $n = 10$  the branch and bound method of LINDO was used and a feasible solution to the 0/1 ILP (and 0/1 QIP) was found. It was not the optimal solution. When  $n = 20$  LINDO was unable to solve the LP relaxation and the CPLEX code at Purdue University was used to determine the optimal solution. A branch and bound method has not been attempted for the  $n = 20$  problem. Hence, it is still unknown whether the branch and bound method will yield good starting points for the heuristic algorithm.

Tabu Search (TS) incorporates conditions for strategically constraining and freeing the search process, as well as memory functions of varying time spans to intensify and diversify the search. The search proceeds from one solution to another via a move function and attempts to avoid entrapment in local optima by constructing a *tabu list* which is simply a list of previously selected moves. These previously selected moves are then deleted from the set of potential moves associated with the current solution. The underlying assumption is that prohibiting the repetition of moves will prevent the return to earlier local optima.

For our purposes, the heuristic embedded in the TS will be a local improvement scheme. Beginning with an initial feasible solution to an optimization problem, the local improvement procedure attempts to improve upon the trial solution by making small (incremental) changes. A rearrangement operation is applied until a perturbed configuration with an improved objective function value is discovered. The improved arrangement becomes the new trial solution, and the process is repeated until no further incremental improvements can be made. The basic solution approach for TS consists of a *construction* phase that generates a starting solution (hopefully from the 01 ILP) and an *improvement* phase that seeks to iteratively improve upon the starting solution. After *max\_it* iterations of the improvement phase we do one of the following; *intensify* the search by restarting the improvement phase at the current best solution; or *diversify* the search by restarting the improvement phase in an unexplored region of the solution space; or *stop* and display the best solution found. For additional information about TS see Glover (1990), Kelly et al (1991), and Kincaid and Berger (1993).

Several TS codes were written in Fortran 77 by the author. Tables 1 and 2 summarize the TS results for randomly generated data when  $n = 10$  and  $n = 20$ . Column 4 lists the number of tabu moves. Column 5 lists the number of these moves that yielded the best objective function value yet encountered in the search and whose tabu status was over-ridden. Column 6 is *yes* if the recency-based diversification scheme was needed, and *no* otherwise. Column 7 is *yes* if the frequency-based diversification scheme was needed, and *no* otherwise. The parameter *memsiz* refers to the number of moves kept on the tabu list, while *stop* is the number of attempts allowed to escape from a local optimum. The maximum number of neighborhood searches allowed is given by *maxit*. All computational times reported are for a 386-based microcomputer without a math-coprocessor running at 16 MHz. The two DHFR protein structures—L. casei and E. coli—have 159 and 162 atoms respectively. A 20 atom portion of the L. casei protein was used to generate a series of test problems and the resulting MSM was found to be much more difficult than the randomly generated ones.

### References

- Barakat, M.T. and P.M. Dean, "Molecular Structure Matching by Simulated Annealing. I. A Comparison Between Different Cooling Schedules." *J. of Computer-Aided Molecular Design*, **4**, 1990, 295-316.
- \_\_\_\_\_, II. An Exploration of the Evolution of Configuration Landscape Problems," *J. of Computer-Aided Molecular Design*, **4**, 1990, 317-330.
- Glover, F., "Tabu Search: A Tutorial," *Interfaces*, **20**, 1990, 74-94.
- Kelly, J.P, M. Laguna, and F. Glover, "A Study of the Diversification Strategies for the Quadratic Assignment Problem," Working Paper, University of Colorado at Boulder, 1991.
- Kincaid, R.K. and R.T. Berger, "The Damper Placement Problem on Space Truss Structures," accepted s.t. revisions *Location Science* 1993.
- Oral, M. and O. Kettani, "Reformulating Nonlinear Combinatorial Optimization Problems for Higher Computational Efficiency," *European J. of Operational Research*, **58**, 1992, 236-249.

#	itrs.	time (m)	tabu	asp.	d1	d2
1	7	0.14	0	0	no	no
2	7	0.15	0	0	no	no
3	6	0.12	0	0	no	no
4	18	0.35	67	0	no	no
5	21	0.41	69	0	no	no
6	5	0.10	0	0	no	no
7	7	0.14	0	0	no	no
8	6	0.12	0	0	no	no
9	7	0.14	0	0	no	no
10	8	0.16	0	0	no	no

Table 1.  $n = 10$  tabu search results.

#	itrs.	time (m)	tabu	asp.	d1	d2
1	20	1.54	9	0	no	no
2	21	1.61	18	2	no	no
3*	68	5.26	339	5	yes	no
4	15	1.15	6	0	no	no
5	118	9.25	959	13	yes	yes
6	36	2.78	96	7	no	no
7	16	1.23	2	0	no	no
8	17	1.30	3	0	no	no
9	27	2.08	8	3	no	no
10+	134	10.51	1052	23	yes	no

(\*) stop =  $n$  (+) maxit = 100

Table 2.  $n = 20$  tabu search results: memsiz =  $n$ , stop =  $2n$ , maxit = 50.

# **A NUMERICAL STUDY OF MIXING AND COMBUSTION IN HYPERVELOCITY FLOWS THROUGH A SCRAMJET COMBUSTOR MODEL**

by

Professor Ramesh Krishnamurthy  
Department of Mechanical Engineering and Mechanics  
Old Dominion University  
Norfolk, Virginia 23529

## **Abstract**

Interest in high speed, air-breathing propulsion systems such as scramjets has revived in recent years fueled to a large extent by the National Aerospace Plane (NASP) program. These vehicles are expected to fly trans-atmospheric and as a consequence, the Mach number level within the engine/combustor would be rather high ( $M > 5$ ). Ground based testing of such scramjet engines requires a facility that can not only achieve the right Mach number, but also have the proper pressures and temperatures to simulate the combustion processes. At present, only pulse type facilities can provide such high enthalpy flows. The newest of these is the free-piston shock tunnel, T5 located at GALCIT. Recently, a generic combustor model was tested in T5, and the experimental data from that study is analyzed in the present report.

The available experimental data from T5 are essentially the static pressures on the injection wall and the one opposite to it. Thus a principal aim of the present study was to validate the available experimental data by using a proven CFD tool and to then investigate the performance characteristics of the combustor model, such as, the mixing efficiency and combustion efficiency. For this purpose, in this study, the code GASP [1] has been used.

A schematic of the combustor model is shown in Figure 1. The flow is supersonic along the length of the combustor. Earlier investigations have revealed that for the  $15^\circ$  fuel injection considered here, the recirculation zone near the injector is negligibly small. Thus the governing equations that were solved were the Parabolized form of the Navier-Stokes (PNS) equations. The finite-rate chemical reactions of gaseous hydrogen and air are modeled by the seven species, seven reactions model of Drummond, Rogers and Hussaini [2]. The grid used was three dimensional. No slip boundary conditions were enforced on all the solid walls, and the centerline of the floor of the combustor was taken to be an axis of symmetry. The flow was taken to be turbulent right from the leading edge of the combustor walls.

Based on the information provided above, the time-varying form of the governing equations were integrated until convergence to a steady state was obtained. Some selected results are presented and discussed next.

Figures 2 and 3 show comparisons between computations and experimental data obtained in this study, for the static pressure distributions on the lower and upper walls of the combustor, respectively. The agreement is seen to be satisfactory. In T5, measurements were done at two different levels of pressure. One set of measurements (Low Pressure) were made under test conditions corresponding to a nominal static pressure at the combustor inlet of 18.3 kPa. The other set (High Pressure) corresponded to a nominal inlet static pressure of 43.9 kPa. At low pressure, both "hot" and cold hydrogen injection runs were made, whereas at high pressure only runs with hot hydrogen injection were performed. Thus we need to examine two issues related to the combustor performance. One is a comparison between hot and cold injection results and the other is the comparison between high and low pressure results.

The performance comparisons will be made in terms of two parameters -- Mixing and Combustion efficiencies. Mixing efficiency is a number between 0 and 1, and is defined as the fraction of the least available reactant that can undergo complete reaction, without further mixing. Combustion efficiency is the fraction of the least available reactant that has reacted completely. Figure 4 shows a plot of mixing and combustion efficiencies for hot and cold injection cases. It is clear that cold injection has higher mixing and combustion efficiencies. This can be attributed to the higher value of the ratio of jet to free stream velocity for cold injection. Figure 5 illustrates the comparison of mixing and combustion efficiencies between high and low pressure results with hot injection. High pressure is seen to result in higher mixing and combustion efficiencies. This results from two effects. One is the higher jet penetration and the other is due to the higher value of the ( $H_2$  -- Air) equivalence ratio for the high pressure case.

Further work needs to be done to refine the grid and also to examine the issue of spatial uniformity of the injectant concentration distribution in the cross-flow plane.

#### References:

1. Walters, R. W., Slack, D. C., Cinella, P., Applebaum, M., and Frost, C., "A Users Guide to GASP", NASA Langley Research Center/Virginia Polytechnic Institute and State University, Revision 0, 1990.
2. Drummond, J. P., Rogers, R. C., and Hussaini, M. Y., "A Detailed Numerical Model of a Supersonic Reacting Mixing Layer", AIAA Paper 86-1427, June 1986.



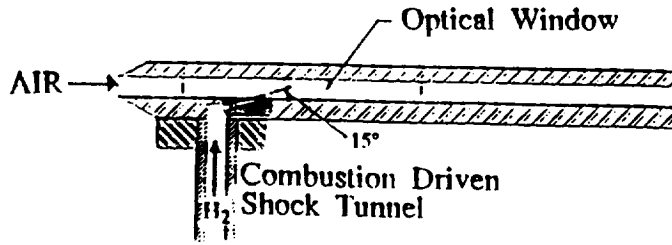


Fig. 1 A schematic of the Rectangular Combustor Model ( 1 in. x 2in. x 28 in. )

COMPARISONS OF CFD RESULTS WITH T5 DATA

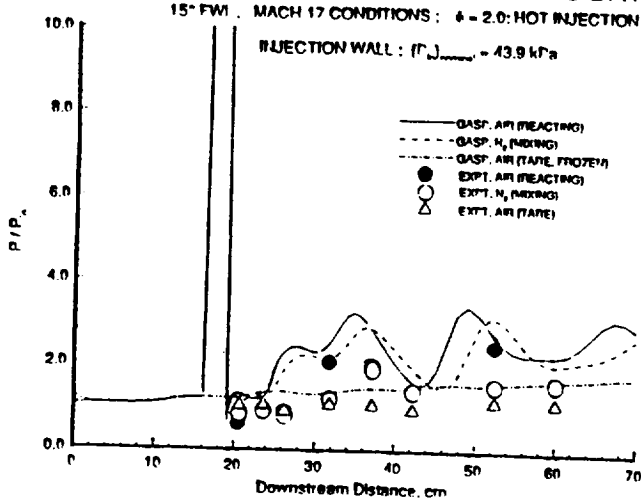


Fig. 2 Static Pressure Distribution on the Centerline of the Injection Wall

COMPARISONS OF CFD RESULTS WITH T5 DATA

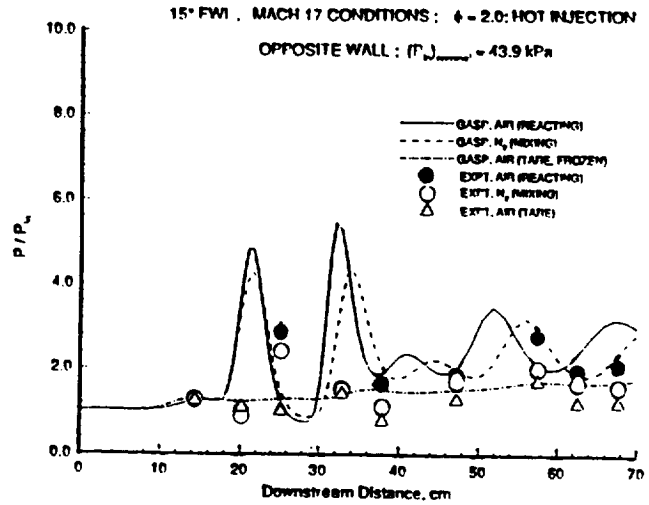


Fig. 3 Static Pressure Distribution on the Centerline of the Opposite Wall

CFD RESULTS

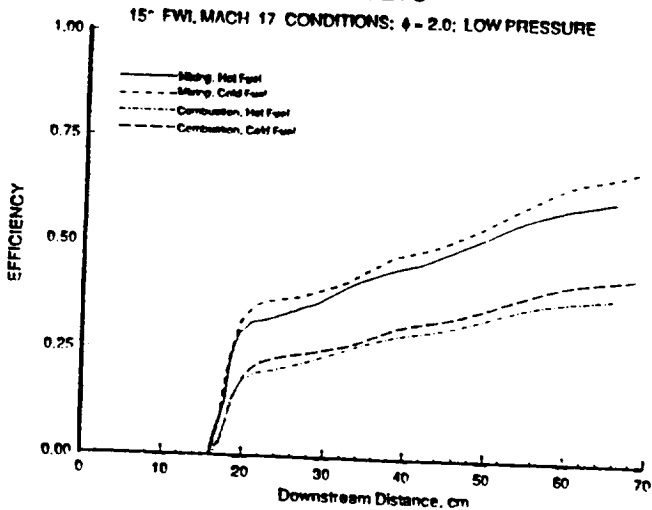


Fig. 4 Variation of the Mixing and Combustion Efficiencies: Hot vs. Cold Injection

CFD RESULTS

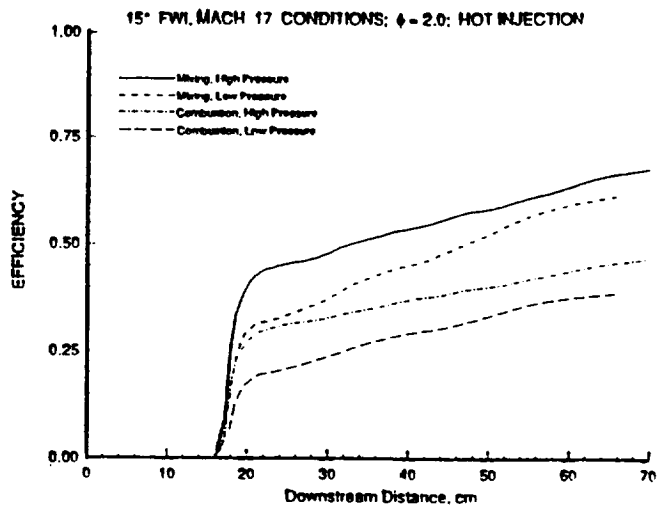


Fig. 5 Variation of the Mixing and Combustion Efficiencies: High vs. Low Pressure

**Experimental Apparatus for Optimization of Flap Position for a Three-Element Airfoil Model**

by

Professor Drew Landman  
Department of Engineering Technology  
Old Dominion University  
Norfolk, VA 23529

**Abstract:** It is proposed to design and build a wind tunnel model comprising a Douglas Aircraft Company three-element high-lift airfoil with internal actuators to move the flap vertically and horizontally under computer control. The model will be used to find the optimum flap location for a fixed angle of attack, slat position and flap deflection angle. The model will span the full tunnel width and lift will be measured by integration of pressure readings taken from midspan taps. It is proposed to conduct experiments in the NASA Langley EFPB 2' x 3' low speed wind tunnel. This report serves as a project overview and a review of work completed to date through funding by the 1993 NASA/ASEE Summer Faculty Fellowship Program.

**Introduction:** The impetus for this project stems from advances in high lift system design coupled with an increasing interest in wind tunnel productivity. A large part of the time currently spent during wind tunnel testing is due to model configuration changes. The elimination of a significant portion of this time would allow more time for experimentation. Further, if model geometry could be changed during a run, new procedures for seeking the optimum geometry may be possible.

One of the long term goals of this project is to extend the technology developed to the NASA Langley Low Turbulence Pressure Tunnel (LTPT), used for higher Reynolds number testing. The remote actuation concept is particularly inviting in a pressurized tunnel since the pressurization cycle time between configuration changes can be eliminated.

It is hoped that a better understanding of the flow physics of a 3 element high lift system will be gained through experimentation with a matrix of flap gap and overhang values. The model can be set for a fixed angle of attack and flap deflection angle, and then a great quantity of data can be generated quickly and automatically.

**Project Outline:** The project requires work in the following areas: mechanical design, wind tunnel instrumentation, computer control, optimization, fluid mechanics, and high lift aerodynamics. This multidisciplinary requirement provides a natural progression towards the goal of a working wind tunnel model.

The first step is to design the mechanical system that will actuate the flap. This first phase was completed this summer. The system was designed to move the flap through a working range of gap and overhang values. Deflection under load was calculated and minimized for maximum positional accuracy. Actuators were located inside the model and external brackets made as slender as possible and streamlined to provide minimum obstruction to flow. At the present time an actuator stage is being constructed for testing.

After the mechanical design specifications have been met, the computer control system can be assembled. It is proposed to use DC gearmotors to move the flap brackets. Control will be through a standard interface in a PC or a Sun workstation. This setup will facilitate the easy interface of existing data acquisition software (LABVIEW) and hardware, with model geometry control.

With control in place, optimization is the next goal. Operational and optimization procedures will have to be developed. When a procedure is established, interfacing custom programs with the data acquisition software (LABVIEW) and the motor control software (source in BASIC, C etc.) will make it possible to optimize the flap position. Optimum might be taken to imply maximum lift coefficient, maximum L/D, minimum drag etc., depending on the requirements imposed.

Finally, a detailed study of the flow physics will be conducted for the optimized position. Results should be correlated with data expected from a fixed model and CFD results. It is hoped that this analysis, and indeed the new test method and procedure, will lead to a better understanding of high lift aerodynamics.

#### **List of Figures:**

Figure 1 - a section through the wing showing the slat, main element, and flap configuration

Figure 2 - a three dimensional conceptual drawing showing the two degree of freedom actuator stage used to move the flap.

Figure 3 - a view of a portion of the bottom of the wing showing gearmotor location and an actuator stage

Figure 1

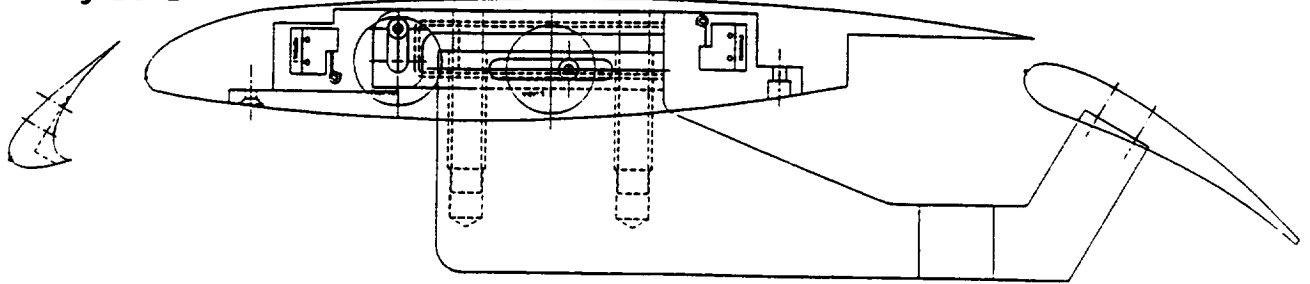


Figure 2

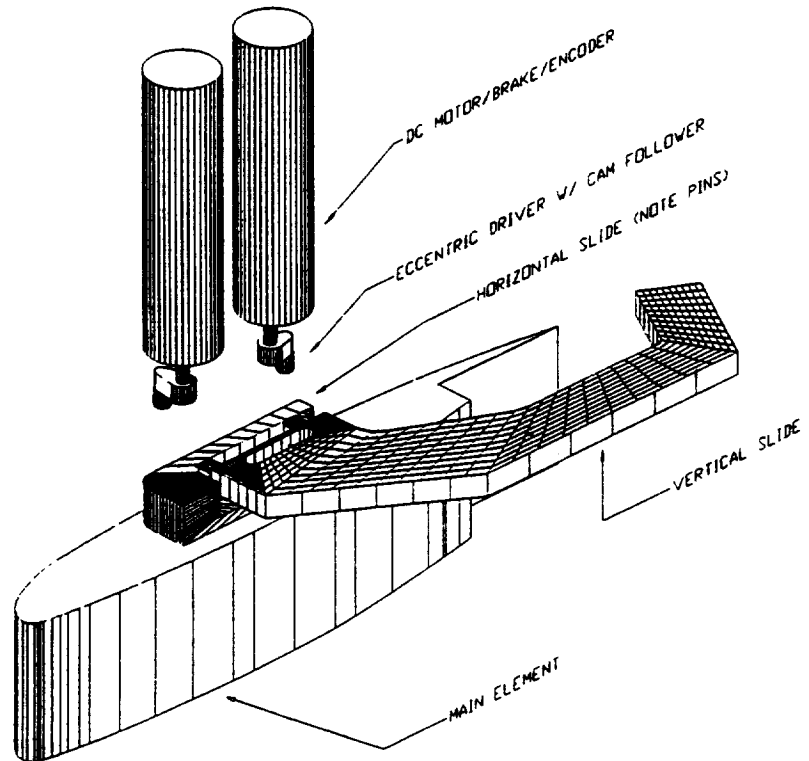
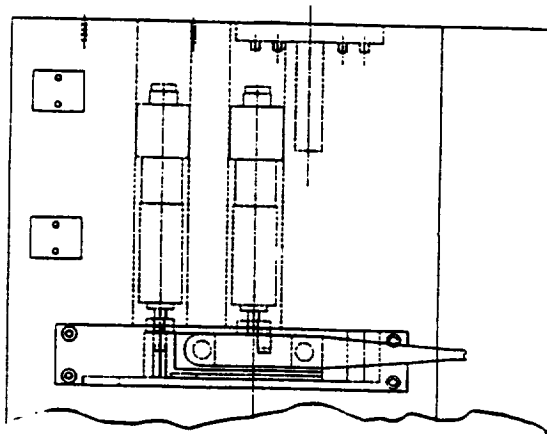


Figure 3



**An Overview on Development of Neural Network Technology**

by

Professor Chun-Shin Lin  
Electrical and Computer Engineering  
University of Missouri-Columbia  
Columbia, MO 65211

**Abstract**

The study has been to obtain a bird's-eye view of the current neural network technology and the neural network research activities in NASA. The purpose was two fold. One was to provide a reference document for NASA researchers who want to apply neural network techniques to solve their problems. Another one was to report our survey results regarding NASA research activities and provide a view on what NASA is doing, what potential difficulty exists and what NASA can/should do. In ten week study period, we interviewed ten neural network researchers in the Langley Research Center and sent out 36 survey forms to researchers at the Johnson Space Center, Lewis Research Center, Ames Research Center and Jet Propulsion Laboratory. We also sent out 60 similar forms to educators and corporation researchers to collect general opinions regarding this field. Twenty-eight survey forms, 11 from NASA researchers and 17 from outside, were returned. Survey results were reported in our final report. In the final report, we first provided an overview on the neural network technology. We reviewed ten neural network structures, discussed the applications in five major areas, and compared the analog, digital and hybrid electronic implementation of neural networks. In the second part, we summarized known NASA neural network research studies and reported the results of the questionnaire survey. Survey results show that most studies are still in the development and feasibility study stage. We compared the techniques, application areas, researchers' opinions on this technology, and many aspects between NASA and non-NASA groups. We also summarized their opinions on difficulties encountered. Applications are considered the top research priority by most researchers. Hardware development and learning algorithm improvement are the next. The lack of financial and management support is among the difficulties in research study. All researchers agree that the use of neural networks could result in cost saving. Fault tolerance has been claimed as one important feature of neural computing. However, the survey indicates that very few studies address this issue. Fault tolerance is important in space mission and aircraft control. We believe that it is worthy for NASA to devote more efforts into the utilization of this feature.

# **MECHANICALLY FASTENED COMPOSITE LAMINATES SUBJECTED TO COMBINED BEARING-BYPASS AND SHEAR LOADING**

by

Professor Erdogan Madenci  
Department of Aerospace and Mechanical Engineering  
University of Arizona  
Tucson, Arizona 85721

## **Abstract**

Bolts and rivets provide a means of load transfer in the construction of aircraft. However, they give rise to stress concentrations and are often the source and location of static and fatigue failures. Furthermore, fastener holes are prone to cracks during take-off and landing. These cracks present the most common origin of structural failures in aircraft. Therefore, accurate determination of the contact stresses associated with such loaded holes in mechanically fastened joints is essential to reliable strength evaluation and failure prediction.

As the laminate is subjected to loading, the contact region, whose extent is not known, develops between the fastener and the hole boundary. The fastener exerts loading on the hole boundary through this contact region, which consists of slip and no-slip zones due to friction, Figure 1. The presence of the unknown contact stress distribution over the contact region between the pin and the composite laminate, material anisotropy, friction between the pin and the laminate, pin-hole clearance, combined bearing-bypass and shear loading, and finite geometry of the laminate result in a complex non-linear problem. In the case of bearing-bypass loading in compression, this non-linear problem is further complicated by the presence of dual contact regions.

Previous research concerning the analysis of mechanical joints subjected to combined bearing-bypass and shear loading is non-existent. In the case of bearing-bypass loading only, except for the study conducted by Naik and Crews (1991), others employed the concept of superposition which is not valid for this non-linear problem. Naik and Crews applied a linear finite element analysis with conditions along the pin-hole contact region specified as displacement constraint equations. The major shortcoming of this method is that the variation of the contact region as a function of the applied load should be known a priori. Also, their analysis is limited to symmetric geometry and material systems, and frictionless boundary conditions. Since the contact stress distribution and the contact region are not known a priori, they did not directly impose the boundary conditions appropriate for modelling the contact and on-contact regions between the fastener and the hole. Furthermore, finite element analysis is not suitable for iterative design calculations for optimizing laminate construction in the presence of fasteners under complex loading conditions.

In this study, the solution method developed by Madenci and Ileri (1992a,b) has been extended to determine the contact stresses in mechanical joints under (a) combined bearing-bypass and shear loading, (b) bearing-bypass loading in compression resulting in dual contact regions.

In the absence of shear loading, bypass loading has a significant effect on the contact stresses and contact angle. As shown in Figure 2, the peak stresses and the contact angle decrease for increasing bypass loading. The influence of shear loading is captured in Figure 3. It results in an asymmetric stress variation with higher peak value than that of without shear loading. However, the effect of shear loading on the remaining stress components and the contact angle is negligible. The influence of bypass loading in the presence of shear loading is shown in Figure 4. As expected, the variation of contact stresses is asymmetric and that the contact angle decreases for increasing bypass loading. Bearing-bypass loading in compression results in two contact regions, side-A and side-B corresponding to the applied and bypass loads, respectively. For a bearing-bypass ratio of 2, the contact stresses and the contact angles are presented in Figure 5. A significant portion of the contact region is in compression and that the stress concentration is lower than that of the unloaded hole case. In this study, the specimen geometry is specified by these parameters:  $L=292$  mm,  $H=203$  mm,  $R=25.4$  mm,  $I=191$  mm,  $h=101.5$  mm,  $\lambda=.508$  mm. The material is quasi-isotropic with lamina properties:  $E_L=37.2$  GPa,  $E_T=12.3$  GPa,  $G_{LT}=3.93$  GPa,  $\nu=.3$ .

It can be concluded that the effect of bypass loading and bearing-bypass loading in compression is favorable for efficient joint design. However, the presence of shear loading results in a higher tangential peak stress; thus, it reduces the strength of the joint. Also, these results illustrate the capability of this solution method for computing contact stresses in pin-loaded holes under various loading conditions while capturing the effects of friction, free edges, end distance, pin-hole clearance, and material anisotropy on the contact stresses.

#### References:

- Naik, R. and Crews, J. H., Jr., 1991, "Stress Analysis Method for Clearance-Fit Joints with Bearing-Bypass Loading," *AIAA Journal*, Vol. 29, pp. 89-95.
- Madenci, E. and Ileri, L., 1992a, "Analytical Determination of Contact Stresses in Mechanically Fastened Composite Laminates with Finite Boundaries," *International Journal of Solids and Structures* (in press).
- Madenci, E. and Ileri, L., 1992b, "Contact Stresses and Stress Intensity Factors for a Pin-Loaded Hole with Edge Cracks in Finite Orthotropic Laminates," *ASME Journal of Applied Mechanics* (accepted for publication).

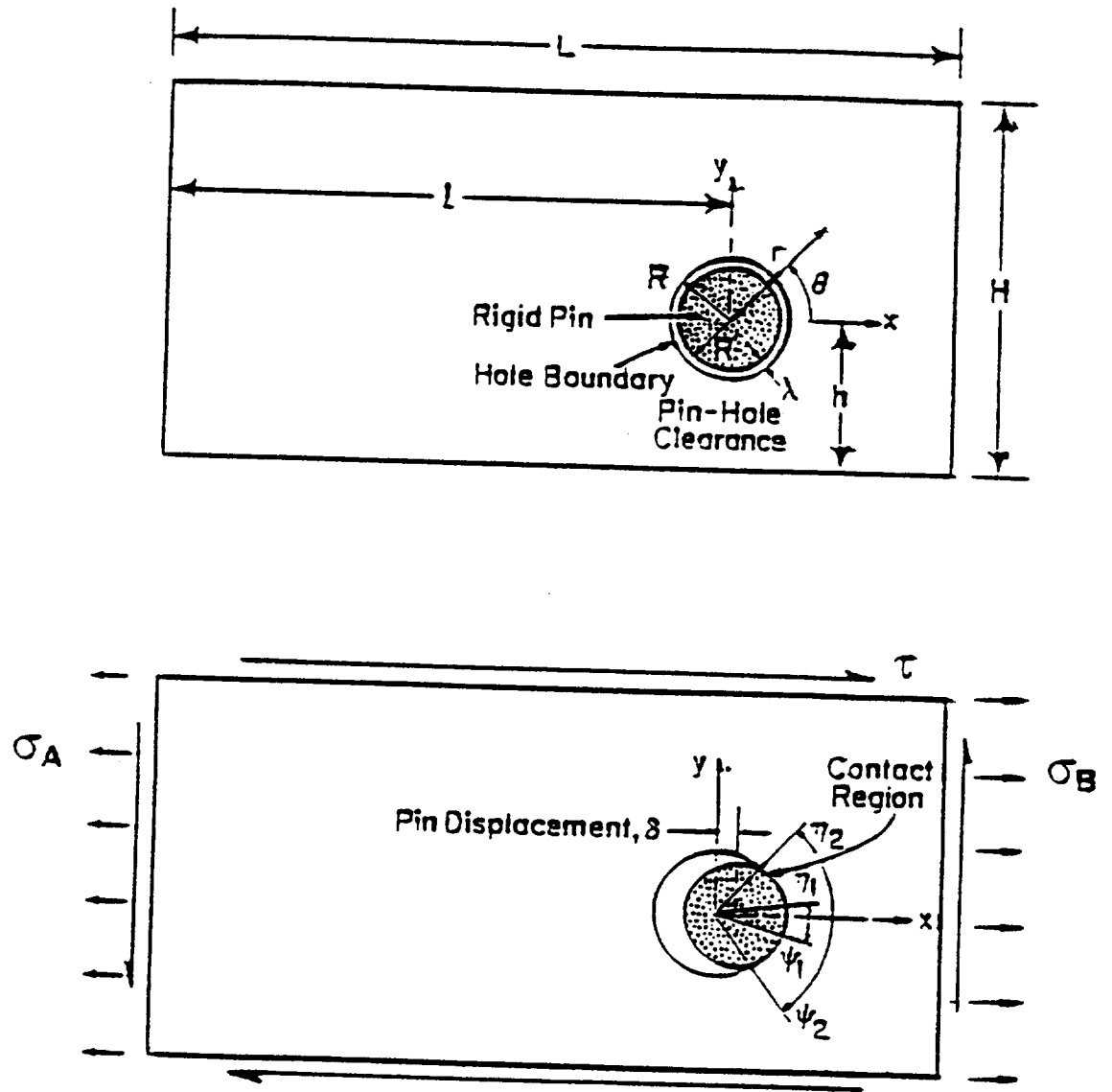


Figure 1 Position of the fastener before and after deformation



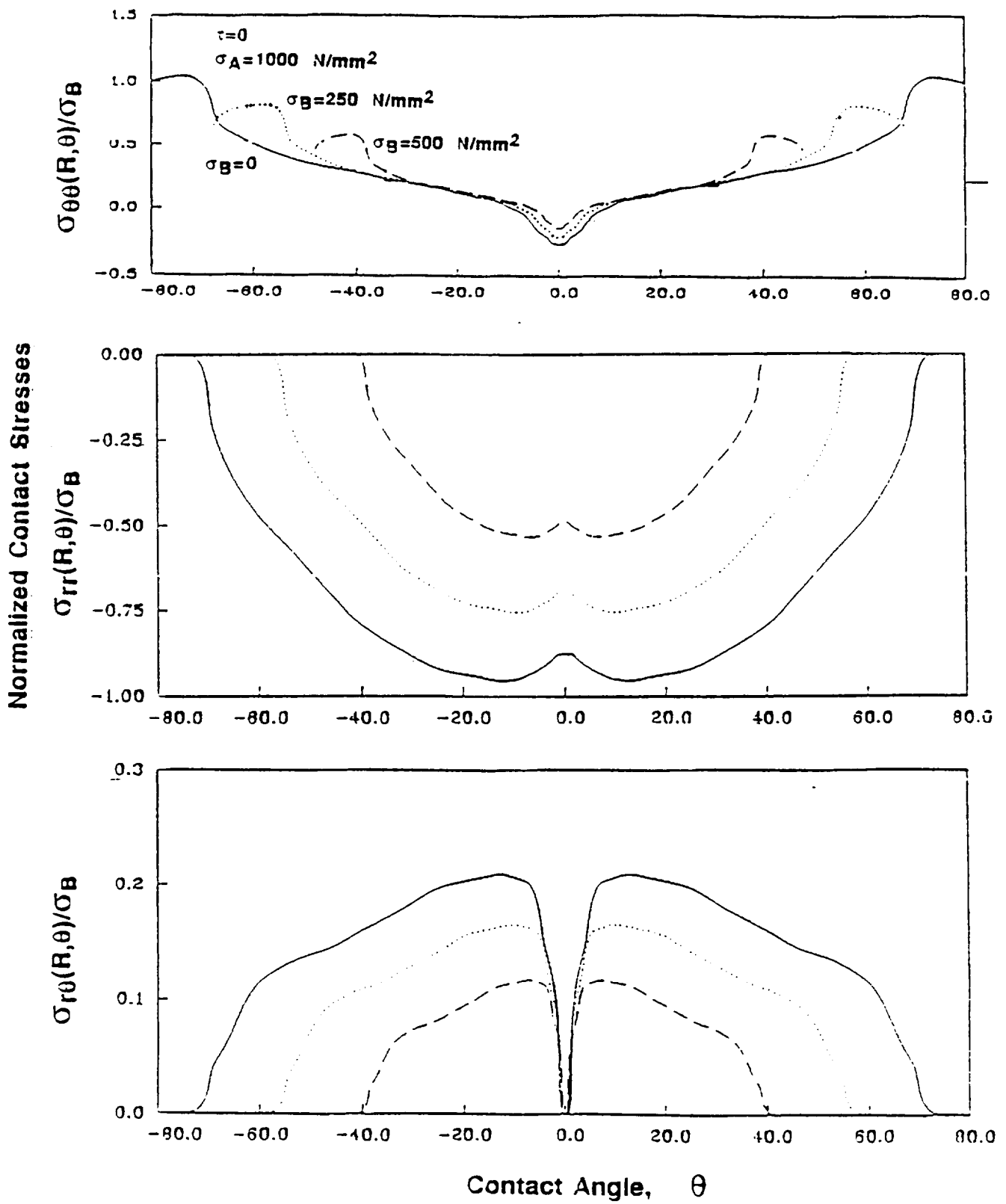


Figure 2 Variation of contact stresses for a range of bypass loads in the absence of shear loading

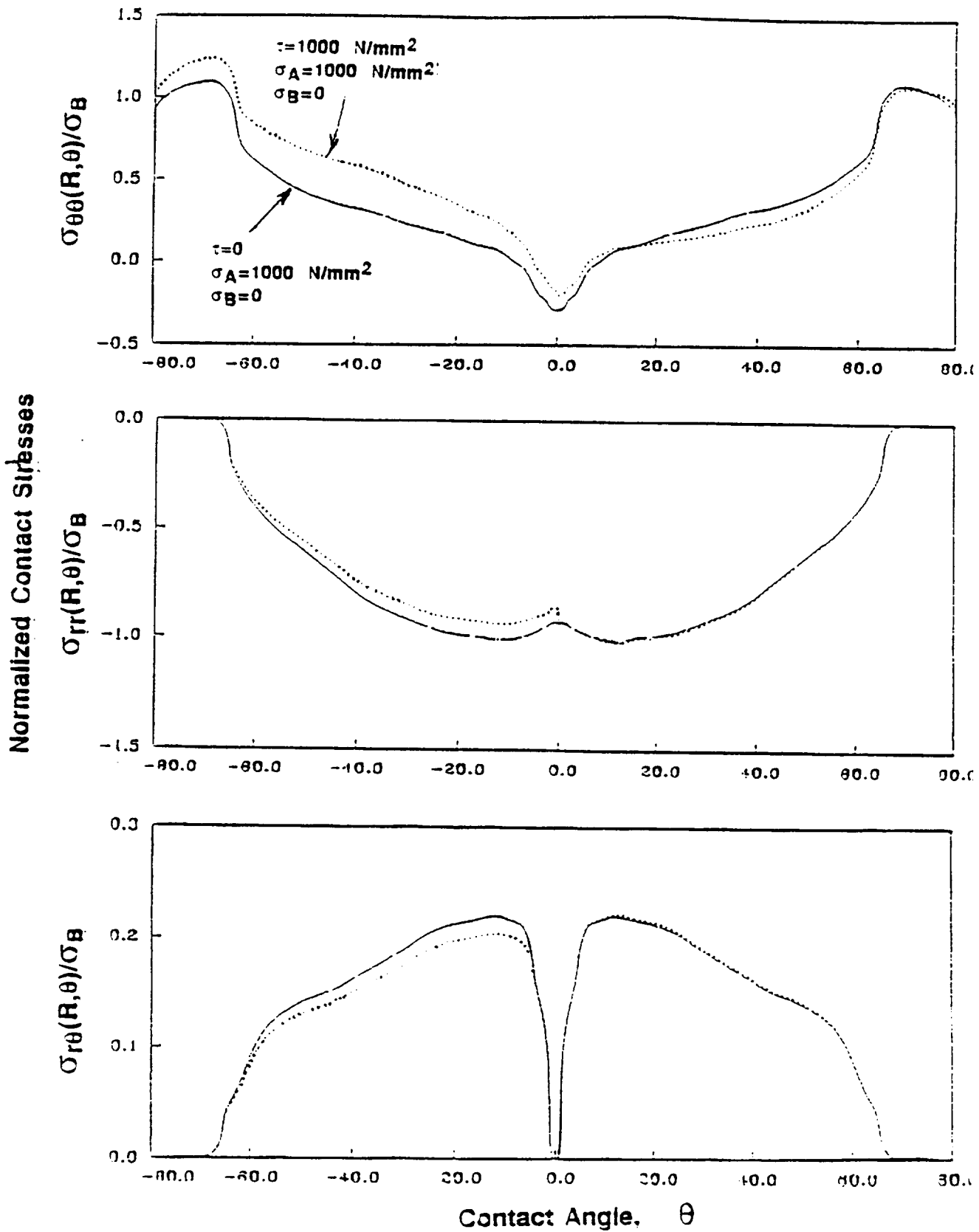


Figure 3 The effect of shear loading on the contact stresses in the absence of bypass loading

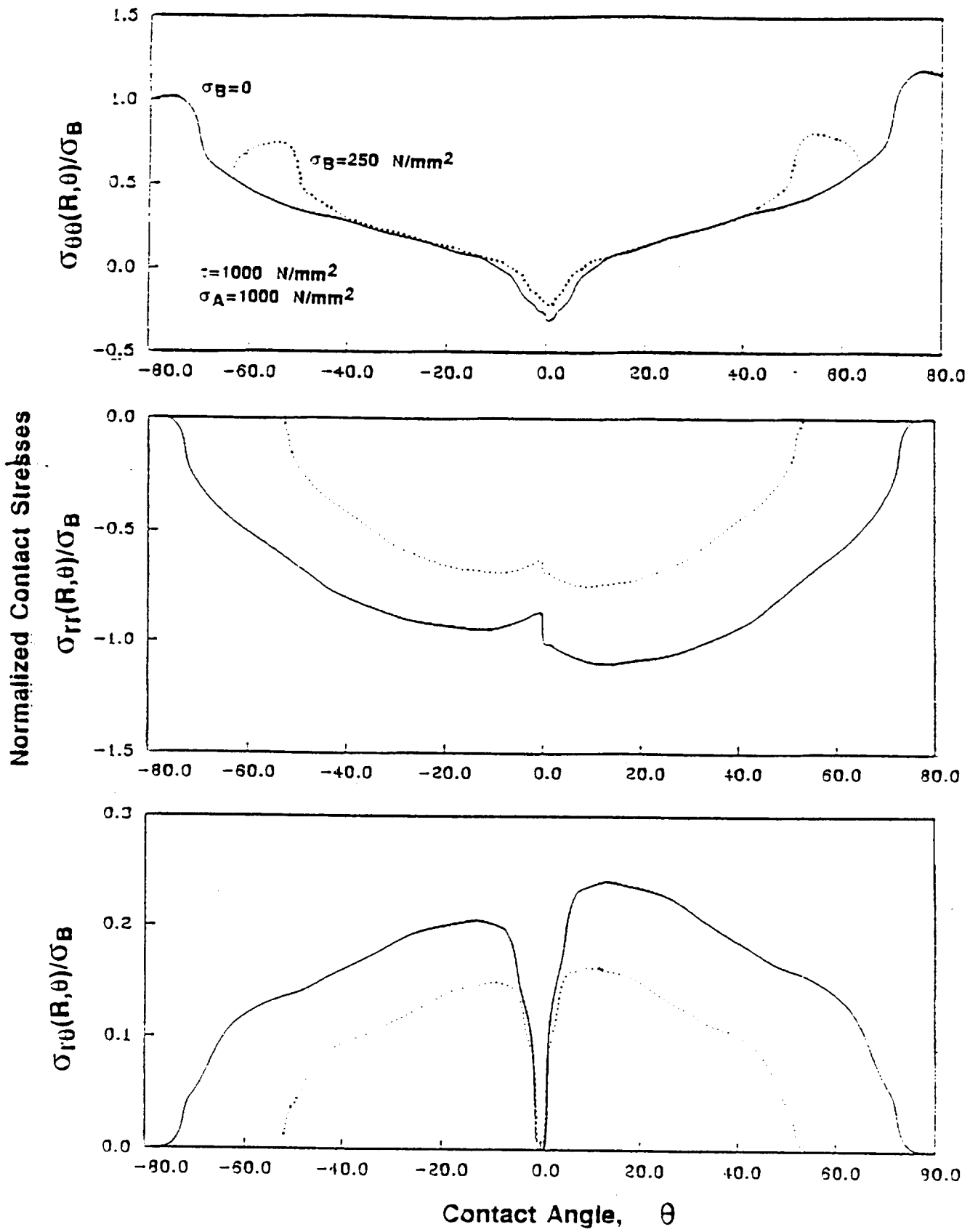


Figure 4 Variation of contact stresses for combined bearing-bypass and shear loading

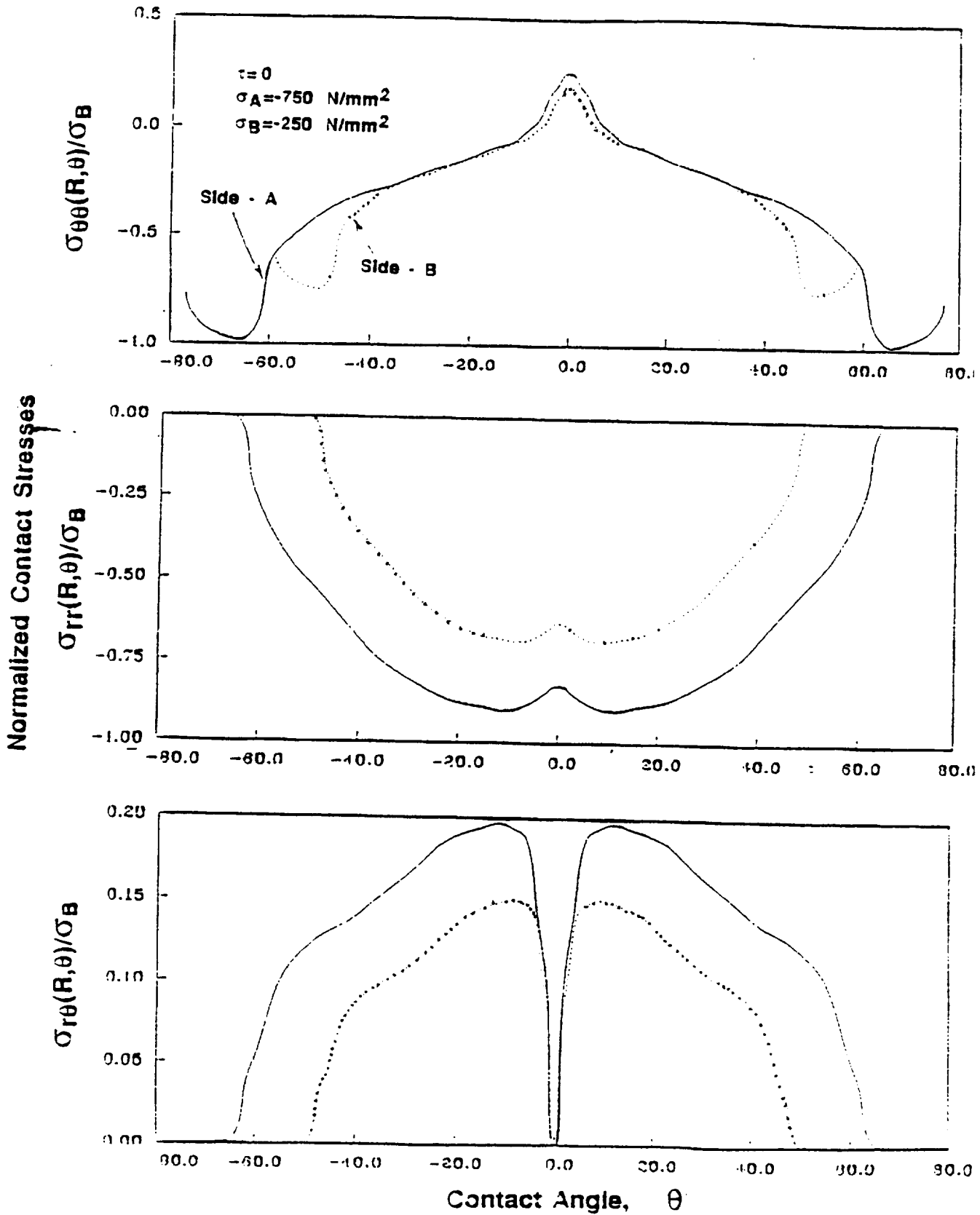


Figure 5 Variation of contact stresses on each side of the fastener when bearing-bypass loading is in compression

## RADIATIONS FROM HOT NUCLEI

Professor F. Bary Malik  
Physics Department  
Southern Illinois University  
Carbondale, IL 62901

### Abstract

The investigation indicates that nuclei with excitation energy of a few hundred MeV to BeV are more likely to radiate hot nuclear clusters than neutrons. These daughter clusters could, further, de-excite emitting other hot nuclei, and the chain continues until these nuclei cool off sufficiently to evaporate primarily neutrons. A few GeV excited nuclei could radiate elementary particles preferentially over neutrons.

Impact of space radiation with materials (for example, spacecraft) produces highly excited nuclei which cool down emitting electromagnetic and particle radiations. At a few MeV excitation energy neutron emission becomes more dominant than gamma-ray emission and one often attributes the cooling to take place by successive neutron decay. However, a recent experiment [1] studying the cooling process of 396 MeV excited  $^{190}\text{Hg}$  casts some doubt on this thinking, and the purpose of this investigation is to explore the possibility of other types of nuclear emission which might out-compete with neutron evaporation.

Our earlier investigation [2] on the fragmentation of  $^{16}\text{O}$  by protons done in connection with cosmic elemental abundance studies indicates that a significant part of fragmentation occurs through a statistical process that envisages formation of an intermediate excited compound system. This decays to two fragments. The study done for a few tens to a few hundreds of MeV incident proton energies reveals two interesting points (Table 1): (a) emission of nuclei heavier than neutrons, protons, and alphas may be more probable, and (b) these nuclei are emitted preferentially in excited states which may further emit gamma rays and/or other nuclear radiation.

We extend the study to calculate the emission probabilities of hot heavy nuclei relative to neutrons from 396 MeV  $^{190}\text{Hg}$ . At this excitation, the transmission coefficient in the final channel between a daughter and the parent could be set to one [3], and the decay probability,  $P(I, U)$  is simply governed by available phase phase and given by

$$P(I, U) \sim \int \rho_1(U_1) \rho_2(E - U_1) dU_1 \quad (1)$$

where  $U$  and  $U_1$  are, respectively, excitation energies of a parent and one of its

daughter nuclei.  $E$  is the total available energy which is also the domain of integration.  $\rho_1$  and  $\rho_2$  are the level density functions of two final fragments. We have evaluated equation (1) using Fong's approximation [4] for the emission of neutrons and other nuclei and present some typical results in Table 2. We find that (a) emission probabilities of many heavy clusters exceed that of neutrons by several orders of magnitude, (b) these clusters are preferentially emitted in excited states, and (c) with considerable kinetic energies. These reactions are exothermic since  $Q$  values are positive. These hot emitted clusters could further radiate other heavy nuclei, for example, Gd in Table 2 has enough excitation to radiate C, O, etc. This "chain" continues until one of the products cools off sufficiently to emit preferentially neutrons.

At 4 GeV excitation of  $^{190}\text{Hg}$ , the  $\Lambda$  and  $\Delta$  emissions compete with that of neutrons; however, hot cluster radiations dominate.

1. S. Beierdorf, R. A. Esterlund, M. Knaack, P. Petzelt, F. P. Hessberger, V. Ninov, and A. Luetgen, Preprint (1992).
2. B. Comani-Tabrizi and F. B. Malik, J. Phys. G.: Nucl. Phys **8**, 1447 (1982).
3. F. B. Malik, Invited talk at 2. international conference on atomic and nuclear clusters, Greece, July 1993.
4. P. Fong, Statistical Theory of Nuclear Fission (Gordon and Breach, New York, 1969).

**Table 1:** Decay Widths in MeV of  $^{17}\text{F}$  to Fragments Listed in Columns 2-5 for Incident Proton Energies Noted in Column 1.

$E_p$ (MeV)	$p + ^{16}\text{O}$	$n + ^{16}\text{F}$	$^4\text{He} + ^{13}\text{N}$	$^5\text{Li} + ^{12}\text{C}$	$^8\text{B} + ^9\text{Be}$
34	3.8	0.05	0.64	0.41	0.04
38	4.2	0.06	0.60	0.39	0.05
42	1.0	0.06	0.38	1.80	0.04

**Table 2:** Decay Probabilities Noted in Last Column of 396 MeV Excited  $^{190}\text{Hg}$  to Pairs Listed in Column 1. Columns 2-3 List Q-Value, Excitation Energy (EX.EN), and Kinetic Energy (K. E) Associated With Each Pair.

Daughters	Q (MeV)	EX.EN (MeV)	K. E (MeV)	Yields
$^{94}\text{Zr} + ^{96}\text{Zr}$	141	383	154	$6.7 \times 10^{85}$
$^{50}\text{Ca} + ^{140}\text{Nd}$	93	369	126	$2.7 \times 10^{84}$
$^{42}\text{S} + ^{48}\text{Gd}$	61	351	115	$1.0 \times 10^{84}$
$n + ^{189}\text{Hg}$	- 8.0	388	0	$1.0 \times 10^{77}$

**REVIEW AND ANALYSIS OF DENSE LINEAR SYSTEM SOLVER PACKAGE FOR  
DISTRIBUTED MEMORY MACHINES**

by

H. N. Narang  
Dept. of Computer Science  
Tuskegee University  
Tuskegee, AL 36088

**ABSTRACT**

A dense linear system solver package recently developed at the University of Texas at Austin for distributed memory machine (e.g. Intel Paragon) has been reviewed and analyzed. The package contains about 45 software routines, some written in FORTRAN, and some in C-language, and forms the basis for parallel/distributed solutions of systems of linear equations encountered in many problems of scientific and engineering nature. The package, being studied by the Computer Applications Branch of the Analysis and Computation Division, may provide a significant computational resource for NASA scientists and engineers in parallel/distributed computing.

Since the package is new and not well tested or documented, many of its underlying concepts and implementations were unclear; our task was to review, analyze, and critique the package as a step in the process that will enable scientists and engineers to apply it to the solution of their problems.

All routines in the package were reviewed and analyzed. Underlying theory or concepts which exist in the form of published papers or technical reports, or memos, were either obtained from the author, or from the scientific literature; and general algorithms, explanations, examples, and critiques have been provided to explain the workings of these programs. Wherever the things were still unclear, communications were made with the developer (author), either by telephone or by electronic mail, to understand the workings of the routines. Whenever possible, tests were made to verify the concepts and logic employed in their implementations. A detailed report is being separately documented to explain the workings of these routines.

**INTRODUCTION**

The solutions of linear systems of equations is needed in many science and engineering applications which include structural mechanics, fluid dynamics, chemical reactions, heat transfer, weather prediction, and climate modeling. Many physical phenomena which model a system of ordinary or partial differential equations eventually lead to the solution of a linear system of equations when discretized.

For many years, computer codes have been developed to solve these systems of equations and made available in the form of standard software packages such as LINPACK and LAPACK. Both



these packages are based on BLAS1, BLAS2, BLAS3 (Basic Linear Algebra Subprograms) which mathematicians developed over 15 years to do matrix computations [13, 20, 32, 35, 36, 38]. Whereas, LINPACK [14, 15, 37, 38, 42] provides codes for solving these systems of equations on uniprocessor machines, LAPACK [3, 7, 8, 9, 14, 15, 23, 32, 34, 37] contains the software routines to solve these systems on shared memory multiprocessors and supercomputers. Attempts have recently been made [2, 3, 4, 5, 6, 8, 9, 10, 11, 12, 15, 16, 18, 19, 21, 22, 23, 24, 27, 28, 31, 33, 34, 40, 44]) to develop the software packages to solve these systems on distributed memory machines such as Intel's hypercubes and a network of machines. The anticipation is that future trends of the scientific computations will be on distributed memory machines and/or on network of smaller machines, and hence, this thrust in the development of codes for these architectures.

Although one can program distributed memory machines to solve scientific problems, the state of the art has not developed to the extent that the programmer does not have to be concerned about the machine architecture and its implications for algorithm selection and implementation. To advance the state of this art, as well as to apply the existing art to various scientific and engineering applications, the Langley Research Center, as part of the High Performance Computing and Communication Program, acquired an experimental machine called Paragon. This is developed by Intel Corporation of Oregon and is designed to interconnect hundreds of processors in a rectangular mesh network. Each of the processors has its own memory (32 MB), and the system can simultaneously and cooperatively solve many applications on a subset of the total number of processors (called partition) for each application [41, 43].

The machine, along with the other software, came with a software package called MPLINPACK or Multiple Processors Linear Equations Solver Package. This software has proven to be very efficient on the Paragon. Our objective was to review and analyze, the software modules to better understand the underlying theory and implementation features that are responsible for its efficiency.

There are about 45 modules written both in FORTRAN and C-languages, which can be categorized into five classes - Data Distribution Routines, Data Communication Routines, Computation Routines, Global Combination Routines, and Auxiliary Routines. These were reviewed and analyzed. Sample tests were run to validate and further understand the underlying theory and concepts for some of the modules.

In certain modules, the concepts were so new or recent that the information was only available through private technical reports or memos from the author (Professor Robert Van de Geign at the University of Texas at Austin). In particular, the concept of TREE, CTREE in information broadcasting [17, 25, 41], Efficient Global Combine Operations [18, 19], and the implementation of FORCE-type messages [26, 43] in certain communication routines were researched and discussions made with the developer, as well as researchers in CAB and Intel Corporation scientists to understand and analyze these routines. A detailed technical report is being published and will be made available to the staff of CAB and other interested researchers.

An interesting problem came up when acceptance tests, consisting of a large system of equations (of the order of 9000 x 9000) were being conducted by Mr. Bulle of CAB on a rectangular grid of nodes for this machine (Paragon). It was discovered that the performance of the system was much better on an elongated grid (2 x 32 grid) than on its transposed grid (32 x 2 grid). After careful analysis, and discussions with the author (developer), we learned that the software employed Gauss elimination (row) procedure and used different techniques of information communication in one direction of the grid (across the columns) than in the other direction (down the columns). That is, the information (pivot row indices, column and row factored panels) broadcast across the column nodes is done in pipelined (ring) fashion, whereas the information (pivot element and pivot row indices) broadcast down the column nodes uses the CTREE technique. Since the CTREE broadcast technique is slower than the pipelining technique, the fewer node rows in a grid would give better performance.

### ACKNOWLEDGEMENTS

The author is thankful to Mr. Richard Bulle of CAB, ACD, NASA Langley Research Center for many useful discussions, Dr. Jules Lambiotte, Head, Computer Applications Branch, NASA Langley Research Center for the opportunity to work on the project, and Dr. R. A. Van de Geijn of the Computer Science Department, University of Texas at Austin for many discussions, clarifications, and for providing the necessary literature and technical reports.

### REFERENCES

1. Chu, E.; and George, A.: QR Factorization of a Dense Matrix on a Hypercube Multiprocessor; SIAM J. Sci. Stat. Computing, Vol. 11, No. 5, pp. 990-1028, September 1990.
2. Choi, J.; Donzarra, J. J.; and Walker, D. W.: The Design of Scalable Libraries for Distributed Memory Concurrent Computers. Proceedings of the Workshop on Environments and Tools for Parallel Scientific Computing, Saint Hilaire du Touvet, France, September 7-8, 1992.
3. Anderson, E., et al: Basic Linear Algebra Communication Subprograms. Proceedings of the Sixth Distributed Memory Computing Conference, pp. 287-290, IEEE Press, 1991.
4. Li, G. and Coleman, T. F.: A Parallel Triangular Solver for a Distributed Memory Multiprocessor. SIAM J. Science Stat. Computing, Vol. 9, No. 1, pp. 485-502, 1990.
5. Anderson, E. and et al: A Look at Scalable Dense Linear Algebra Libraries. J. H. Saltz, Editor. Proceedings of the 1992 Scalable High Performance Computing Conference, IEEE Press, 1992.
6. Anderson et al: LAPACK for Distributed Memory Architectures: Progress Report, Parallel Processing for Scientific Computing, Fifth SIAM Conference, SIAM Press, 1990.

7. Anderson, E., et al: LAPACK User's Guide. SIAM Press, Philadelphia, PA, 1992.
8. Anderson, E., et al: A Portable Linear Algebra Library for High Performance Computers. In Proceedings of Supercomputing, 1990, pages 1-10, IEEE Press, (also available as LAPACK Working Note #20, 1990).
9. Donzarra, J. J. and Ostrouchou, S.: LAPACK Working Note #24: Block Factorization Algorithms on the Intel iPSC/860, Tech. Report CS-90-115, University of Tennessee at Knoxville, Computer Science Department, October 1990.
10. Geijn, R. A. van de: Massively Parallel LINPACK Benchmark on the Intel Touchstone Delta and iPSC/860 Systems. Computer Science Report TR-91-28, University of Texas at Austin, 1991.
11. Dongarra, J. J.; and Van de Geijn, R. A.: Reduction to Condensed Form of Eigenvalue Problem on Distributed Memory Architectures. LAPACK Working Note #30, Tech. Report, CS-91-130, University of Tennessee at Knoxville, 1991.
12. Dongarra, J. J.: A Workshop on BLACS. LAPACK Working Note #34, Tech. Report CS-91-134, University of Tennessee, 1991.
13. Dongarra, J. J., et al: A Set of Level 3 Basic Linear Algebra Subprograms. ACM Transactions on Mathematical Software 16 (1), 1-17, 1990.
14. Dongarra, J. J. et al: Implementing Linear Algebra Algorithms for Dense Matrices on a Vector Pipeline Machine. SIAM Review, Vol. 26, #1, pp. 91-112, 1984.
15. Gallivan, K. A., et al: Parallel Algorithms for Dense Linear Algebra Computations. SIAM Review, 33, pp. 54-135, 1990.
16. Dammel, J. W., et al: Block LU Factorization. LAPACK Working Note #40, University of Tennessee, 1992.
17. Barnett, M., et al: Optimal Broadcasting in Mesh-Connected Architectures. Tech. Report, TR-91-38, University of Texas at Austin, December 4, 1991.
18. Van de Geijn, R. A. : On Global Combine Operations. LAPACK Working Note #29, Tech. Report CS-91-129, University of Tennessee, 1991.
19. Van de Geign, R. A.: Efficient Global Combine Operations. In Sixth Distributed Memory Computing Conference Proceedings, pp. 291-294, IEEE Press, 1991.
20. Choi, J., et al: Level 3 BLAS for Distributed Memory Concurrent Computers. Proceedings of the Workshop on Environments and Tools for Parallel Scientific Computing, St. Hilaire du Touvet, France, Septe. 7-8, 1992.

21. Anderson, E., et al: Performance of LAPACK: A Portable Library of Numerical Linear Algebra Routines. LAPACK Working Note #44, Tech. Report CS-92-156, University of Tennessee, 1992
22. Dongarra, J. J., et al: An Object Oriented Design for High Performance Linear Algebra on Distributed Memory Architectures. Tech. Report, Oak Ridge National Lab., 1993
23. Anderson, E., et al: Prospectus for an Extension to LAPACK: A Portable Linear Algebra Library for High Performance Computers. LAPACK Working Note #26, CS-90-118, University of Tennessee, 1991.
24. Dammal, J. and Kahan, W.: On Designing High Performance Numerical Libraries. LAPACK Working Note #39, University of Tennessee, 1991.
25. Ho, C. T., and Johnsson, S. L.: Distributed Routing Algorithms for Personalized Communications in Hypercubes. In Proceedings of 1986 International Conference on Parallel Processing, pp. 640-648, IEE Press, 1986.
26. Bokhari, S. H.: Complete Exchange on the iPSC 860, ICASE, Tech. Report 91-4, NASA LaRC, Hampton, VA, January 1991. Memory Multiprocessors. SIAM J. Sci. Stat. Computing, #3, pp. 558-587, 1988.
27. Heath, M. T., and Romine, C. H.: Parallel Solution of Triangular Systems on Distributed Memory Multiprocessors. SIAM J. Sci. Stat. Computing, #3, pp. 558-587, 1988.
28. Geist, G. A., and Romine, C. H.: LU Factorization on Distributed Memory Multiprocessor Architectures. SIAM J. Sci. Stat. Comput., Vol. 9, #4, July 1988.
29. Dongarra, J. J., et al: The IBM RISC System/6000 and Linear Algebra Operations. Oak Ridge National Lab. Tech. Report ORNL/TM 11768, pp. 13-24, Dec. 1991.
30. Gallivan, K.: Impact of Hierarchical Memory Systems on Linear Algebra Algorithm Design. Int. J. of Supercomputer Applications, Vol. 2, #1, pp. 12-48, 1989.
31. Choi, J., et al: ScaLAPACK: A Scalable Library for Distributed Memory Concurrent Computers. In Proceedings of the Fourth Symposium on the Massively Parallel Computation (Frontiers' 1992), McLean, VA, October 19-21, 1992. (Also available as LAPACK Working Note #55, University of Tennessee)
32. Dammal, J. W.; Higham, N. J.: Stability of Block Algorithms with Fast Level 3 BLAS. LAPACK Working Note #22, pp. 1-25, University of Tennessee, 1990
33. Choi, J., et al: PUMMA: Parallel Universal Matrix Multiplication Algorithms on Distributed Memory Concurrent Computers. Tech. Report, Oak Ridge National Lab, 1993.

34. Dongarra, J. J.: Two-Dimensional Linear Algebra Communication Subprograms. LAPACK Working Note #37, Tech. Report CS-91-138, University of Tennessee, 1991.
35. Lawson, C. L. et al: Basic Linear Algebra Subprograms for FORTRAN Usage. ACM Trans. Math Soft. 5, pp. 308-323, 1979.
36. Dongarra, J. J.: An Extended Set of FORTRAN Basic Linear Algebra Subprograms. ACM Trans. Math. Soft., Vol. 14, #1, pp. 1-17, 1988.
37. Ortega, James M.: Int. to Parallel and Vector Solutions of Linear Systems. Plenum Press, New York, 1988.
38. Coleman, T. E.; Loan, C. V.: Handbook for Matrix Computations. SIAM Press, Philadelphia, 1988.
39. Dongarra, J. J. and Van de Geijn, R. A.: Reduction to Condensed Form for the Eigen Value Problem on Distributed Memory Architectures. LAPACK Working Note #30, University of Tennessee, 1991.
40. Dongarra, J. J.: Performance of Various Computers Using Standard Linear Equations Software. Tech. Report CS-89-85, University of Tennessee, 1993.
41. Paragon OSF/1, Users Guide, Intel Corporation, 1993.
42. Dongarra, J. J.: LINPACK Working Note #9, Preliminary LINPACK User's Guide, Argonne National Lab., 1977.
43. Paragon OSF/1 C System Calls, Reference Manual, Intel Corporation, 1993.
44. Cosnard, M. , et al: Parallel Gaussian Elimination on a MIMD Computer. Parallel Computing, #6, pp. 275-296, 1988.

# **STRATEGIC PLAN FOR EDUCATION**

by  
Professor Sandra B. Proctor  
School of Social Work  
Norfolk State University  
Norfolk, Virginia 23504

## **ABSTRACT**

### **Introduction**

NASA centers around the country have been asked to prepare a Strategic Plan for Education that will serve to focus and guide each Center's future direction for education. Centers have been allowed the flexibility to conceptualize and operationalize those education-related goals, objectives, and activities deemed pertinent for the Center and its customers. Of crucial importance in the strategic planning process in general is the recognition of the nexus between those center specific goals and objectives and those promulgated by NASA Headquarters. The centerpiece of this planning activity embodies not only the NASA related goals and objectives, but also those identified by the President's committee for the development of national education goals and those developed by the Federal Coordinating Council for Science, Engineering, and Technology.

### **Summary**

The Office of Education at NASA Langley and this researcher engaged in a planned and systematic examination of Langley's educational role. Utilizing several categories of diverse respondents, interview schedules were devised that would elicit specific data. A sample of approximately fifty or more randomly selected individuals were interviewed including all levels of NASA Langley personnel, students, summer faculty, graduate and undergraduate students, and non-NASA personnel. Interviewees were asked to respond to a series of questions that addressed NASA Langley's role in education.

Findings generated encompassed a wide range of viewpoints relative to goals, objectives, and future directions for the Office of Education.

Data gleaned from the interviews also revealed qualities of effective internships for students and faculty and ways that these professional experiences could be improved. Concomitantly, these findings and a review of salient literature will be analyzed qualitatively and form the basis for the Strategic Plan.

**WING DESIGN FOR A CIVIL TILTROTOR TRANSPORT AIRCRAFT:  
A PRELIMINARY STUDY**

by

Professor Masoud Rais-Rohani  
Aerospace Engineering Department  
Mississippi State University  
Mississippi State, MS 39762

**Abstract**

A preliminary study was conducted on the design of the wing-box structure for a civil tiltrotor transport aircraft. The wing structural weight is to be minimized subject to structural and aeroelastic constraints. The composite wing-box structure is composed of skin, stringers, ribs and spars. The design variables include skin ply thicknesses and orientations, and spar cap and stringer cross-sectional areas. With the total task defined, an initial study was conducted to learn more about the intricate dynamic and aeroelastic characteristics of the tiltrotor aircraft and their roles in the wing design. Also, some work was done on the wing finite-element modeling (via PATRAN) which would be used in structural analysis and optimization. Initial studies indicate that in order to limit the wing/rotor aeroelastic and dynamic interactions in the preliminary design, the cruise speed, rotor system and wing geometric attributes must all be held fixed.

**Introduction**

The tiltrotor aircraft is a flight vehicle which combines the efficient take-off, landing, hover and low speed characteristics of a helicopter with the efficient high-speed cruise characteristics of an airplane.<sup>1</sup> With the success of Bell XV-15 program and its derivative the Bell-Boeing V-22, the tiltrotor concept has been seriously considered for civilian applications.<sup>2</sup> The civil tiltrotor transport aircraft is required to carry 40 passengers (8,000 lb) and cruise at 375 Knots with a range of 600 N. Miles. The tiltrotor aircraft is among many V/STOL configurations (e.g., tiltwing, variable-diameter rotor, etc.) that have been considered for civil transport application in the past few years; however, in terms of rapid payload delivery and fuel consumption versus the disk loading and in terms of manufacturability, the tiltrotor is judged as being the most efficient design.<sup>3</sup>

The preliminary efforts in this study have been focused on two tasks: (1) To perform a literature review to learn more about the unique dynamic and aeroelastic characteristics of the tiltrotor configuration and the procedures to analyze them; and (2) To work on the structural modeling and analysis techniques necessary in the tiltrotor wing design optimization. This abstract highlights the important aspects of each task performed.

**Wing Design Problem**

The design objective is to determine the optimum set of structural parameters that minimize the wing structural weight while satisfying all structural and aeroelastic constraints. The wing geometry is to be the same as that defined in a recent Bell Helicopter Textron study.<sup>4</sup> The wing box structural components (i.e., skin, stringers, spars, and ribs) are all made of graphite-epoxy composites. The wing design variables include skin ply thicknesses and orientations, and stringer and spar cap areas. These design variables would allow the tailoring of the composite materials to meet the design requirements most efficiently.

Since the civil tiltrotor aircraft must fly much faster than its military counterpart (i.e., V-22), total drag in general and compressibility drag in particular become important design drivers. The wing airfoil section on V-22 has a thickness to chord ratio of 23%. The structural design requirements on the civil tiltrotor are less stringent than those for the V-22; hence, a thinner

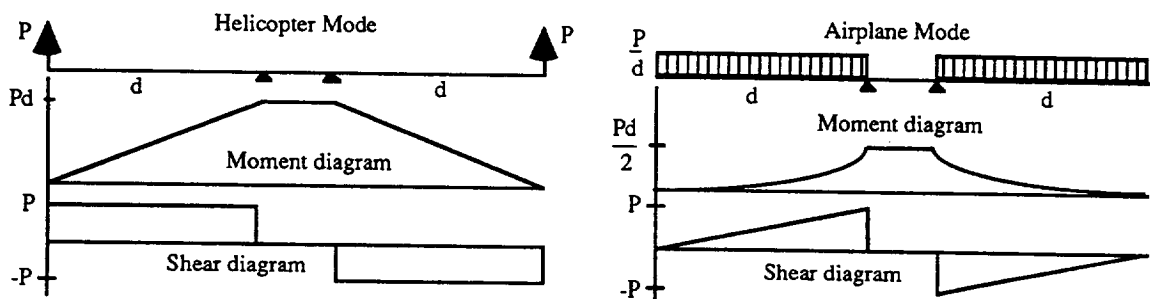
airfoil would satisfy the structural design requirements while reducing the compressibility drag. The goal is to use an 18% thick supercritical airfoil for the civil tiltrotor wing to increase the drag-divergence Mach number and lower the compressibility drag. The wing structural design is based on the limit load factors in helicopter and airplane modes stated in FAR: Part XX (Interim Airworthiness Criteria: Powered Lift Transport Category Aircraft). The 2.0-g vertical jump take-off loads create the highest wing root bending moments as shown in the figure below—setting the requirements for wing strength in the form of maximum stress constraints on the stringers and the spar caps, and maximum strain constraints on the skin plies.

The large proprotor at each wing tip, resembling more like a helicopter rotor than an airplane propeller, produces high dynamic and aerodynamic loads. Furthermore, rotor hub and blade motions along with wing flexibility produce dynamic and aeroelastic couplings that may lead to several instabilities. The instabilities associated with the tiltrotor configuration may be classified as: (1) Mechanical instabilities; and (2) Aeroelastic instabilities. The heavy masses placed at the wing tips reduce the wing bending and torsion frequencies. The wing motions in bending and torsion (symmetric or antisymmetric) set off motions in the rotor hub. The rotor hub motions can cause the blades to depattern which cause further vibration of the rotor hub leading to mechanical instability and an eventual destructive failure. To eliminate this form of instability, the blade natural frequencies in the plane of rotation must be greater than rotor speed.<sup>3</sup> In the airplane mode, the oscillatory aerodynamic and dynamic forces generated by the rotors combined with the flexibility of the wing may tilt the axis of rotation causing the rotor to whirl. This whirling motion changes the fixed-wing aeroelastic flutter to what is known as whirl flutter. To eliminate this form of instability, the wing natural frequencies (mainly torsion) must be kept away from the rotor natural frequencies. Also, more importantly, the wing beamwise bending and torsional frequencies must be kept separated.<sup>5</sup> In this study, in order to limit the wing/rotor dynamic and aeroelastic interactions, the cruise speed, rotor system and wing geometry are all held fixed. Hence, the wing box stiffness is dictated by the aeroelastic instability boundary. The guidelines established in Ref. 4 will be used to create proper design constraints for aeroelastic stability and natural frequency placements.

Some work has also been done on the generation of the finite-element model of the wing/pylon using PATRAN. This model along with material property information will be used in MSC/NASTRAN for the static and dynamic structural analyses of the wing model. Following the completion of this task, and the proper formulation of aeroelastic and structural constraints, the design optimization will proceed.

## References

1. Mark, H. and Lynn R.R., "Aircraft Without Airports-Changing the Way Men Fly," VERTIFLITE, Vol. 34, No. 3, 1988.
2. "Civil Tiltrotor Missions and Applications: A Research Study," Boeing Commercial Aircraft Company, Renton, WA, NASA-CR-177452, Summary Final Report, July 1987.
3. Loewy, R.G., "Aeroelasticity and the Tiltrotor VTOL Aircraft," VERTIFLITE, Vol. 38, No. 3, 1992.
4. Rogers, C. and Reisdorfer, D., "Advanced Material and Structural Concepts, Civil Tiltrotor Point Design-Model 940A," NASA-CR-191446, 1992.
5. Nixon, M.W., "Parametric Studies for Tiltrotor Aeroelastic Stability in High-Speed Flight," Proceedings of the 33rd AIAA/ASME/ASCE/AHS/ASC Structures, Structural Dynamics and Materials Conference, Dallas, Texas, April 13-15, 1992, Part 4, pp. 2027-2037.



Shear and Moment Variations for the Same Total Lift



## A SIMULATION OF GPS AND DIFFERENTIAL GPS SENSORS

by

Dr. James M. Rankin, P.E.  
 Electrical Engineering Department  
 St. Cloud State University  
 St. Cloud, MN 56301

**Introduction**

The Global Positioning System (GPS) is a revolutionary advance in navigation. Users can determine latitude, longitude, and altitude by receiving range information from at least four satellites. The statistical accuracy of the user's position is directly proportional to the statistical accuracy of the range measurement. Range errors are caused by clock errors, ephemeris errors, atmospheric delays, multipath errors and receiver noise. Selective Availability which the military uses to intentionally degrade accuracy for non-authorized users is a major error source. The proportionality constant relating position errors to range errors is the Dilution of Precision (DOP) which is a function of the satellite geometry.

Receivers separated by relatively short distances have the same satellite and atmospheric errors. Differential GPS (DGPS) removes these errors by transmitting pseudorange corrections from a fixed receiver to a mobile receiver. The corrected pseudorange at the moving receiver is now corrupted only by errors from the receiver clock, multipath, and measurement noise.

This paper describes a software package that models position errors for various GPS and DGPS systems. The error model is used in the Real-Time Simulator and Cockpit Technology workstation simulations at the NASA-Langley Research Center. The GPS/DGPS sensor can simulate enroute navigation, instrument approaches, or on-airport navigation.

**Pseudorange Errors**

Pseudorange, a noisy estimate of range, is a measurement of the travel time for the satellite signals. The Course/Acquisition (C/A) code and Precision (P) code are the satellite signals used for the pseudorange measurement. The pseudorange,  $\rho$  model

$$\rho = r + \delta_{eph} + \delta_{iono} + \delta_{trop} + \delta_{SA} + cT + \delta_{mp} + v_{rcvr}$$

includes actual range ( $r$ ) plus ephemeris ( $\delta_{eph}$ ), ionosphere ( $\delta_{iono}$ ), troposphere ( $\delta_{trop}$ ), SA ( $\delta_{SA}$ ), clock ( $cT$ ), multipath ( $\delta_{mp}$ ), and measurement ( $v_{rcvr}$ ) errors. A measurement of the carrier phase can also be used to determine range. The carrier phase measurement (in meters) is

$$\lambda\phi = r - d_{iono} + d_{trop} + \delta_{SV} + \delta_{SA} + \lambda N + \delta_{mp} + v_{carrier}$$

The carrier phase measurement has an integer ambiguity,  $\lambda N$ , that reflects uncertainty about the exact number of wavelengths traveled. By maintaining carrier lock, the value of  $N$  can be determined. (Ionosphere delay is negative for phase and positive for code. )

The ephemeris, ionosphere, troposphere, SA, and multipath errors are modeled as Gauss-Markov, correlated noise processes. These processes have an exponential autocorrelation function,  $R(\tau) = \sigma^2 e^{-\beta|\tau|}$ . The standard deviation and time constants are listed in Table 1. Gauss-Markov terms are simulated by the difference equation

$$x_{k+1} = e^{-\beta \Delta T} x_k + w_k$$

where  $x$  is the parameter being simulated and  $w$  is Gaussian white noise.

Measurement noise is modeled as Gaussian white noise. Code correlators track to 1% of its signal width ( $1\sigma$ ). Carrier phase measurements are accurate to 1% of its wavelength. Measurement noise parameters are shown in Table 2.

### Receiver Models

Pseudorange accuracy is dependent on the satellite signals measured and the receiver sophistication. Since the error sources are independent of each other, the pseudorange error is the sum of errors from each noise source. The pseudorange autocorrelation for a stand-alone C/A code receiver is shown with SA off (in Figure 1) and SA on (in Figure 2). When SA is on, using more sophisticated receivers will not reduce errors significantly.

A DGPS system removes the SA and atmospheric errors that are common in receivers separated by less than 20 km. The remaining errors are due to multipath and measurement noise. The differentially corrected code and carrier phase measurements are

$$\begin{aligned} \bar{p} &= r + cT + (\delta_{mp} + v_{code})_{rcvr} - (\delta_{mp} + v_{code})_{base} \\ \lambda\phi &= r + cT + (\delta_{mp} + v_{carrier})_{mobile} - (\delta_{mp} + v_{carrier})_{base} + \lambda N \end{aligned}$$

### Dilution of Precision (DOP)

DOP values are calculated from the direction cosine vectors pointing from the receiver to the SATs. Statistical error on the X-axis is described as  $\sigma_x = \text{XDOP} * \sigma_p$  where  $\sigma_p$  is the pseudorange error. YDOP and VDOP correspond to the Y and Z axes. HDOP is the horizontal DOP formed by combining X and Y into a radial 2D error. DOP values for Denver Stapleton airport are shown in Table 3. The values were calculated from the model every 10 seconds for one day.

### Software Implementation

The GPS error model is written in C. `gps_init()` initializes the data parameters used in the GPS simulation. `gps_()` is a 1 Hz routine that provides XYZ errors. The user can select from nine GPS/DGPS modes and enable/disable SA. The `calcdop_()` routine calculates XDOP, YDOP, and VDOP. A 24 SAT constellation is simulated using circular orbits and a spherical earth. The DOP values are determined using an all-in-view strategy with an elevation mask of 5 degrees above the horizon. Figure 3 shows the GPS error algorithm.

The horizontal accuracy at the  $2\sigma$  (95%) level is shown in Table 4 for the GPS and DGPS systems modeled. The table assumes an HDOP of 1.6.

### References

- 1) R. Grover Brown and Patrick Y.C. Hwang. "Introduction to Random Signals and Applied Kalman Filtering, 2nd ed." John Wiley & Sons. New York, NY, 1992.
- 2) Technical Characteristics of the NAVSTAR GPS, North Atlantic Treaty Organization (NATO) Navstar GPS Technical Support Group. June 1991.
- 3) Kremer, G; Kalafus, R; Loomis, P; and Reynolds, J. "The Effect of Selective Availability on Differential GPS Corrections". Navigation. Vol. 37, Spring 1990.
- 4) Cannon, M.E., and LaChapelle, G. "Analysis of a High-Performance C/A-Code GPS Receiver in Kinematic Mode". Navigation, Vol. 39, No. 3, Fall 1992.

Error parameter	Standard Dev. ( $1\sigma$ , meters)	Time Constant ( $1/\beta$ , seconds)
Ephemeris	3	1800
Ionosphere	5	1800
Troposphere	2	3600
Multipath, C/A	5	600
Multipath, P	1	600
Multipath, L1 carrier	0.048	600
Integer ambiguity	1	1000
Selective Availability	30	180

Table 1. Gauss-Markov parameters for correlated noise sources.

Model	Standard Deviation (meters)
C/A code, standard corr.	3.0
C/A code, narrow corr.	0.1
P code	0.3
L1 Carrier	0.0019

Table 2. Measurement noise statistics.

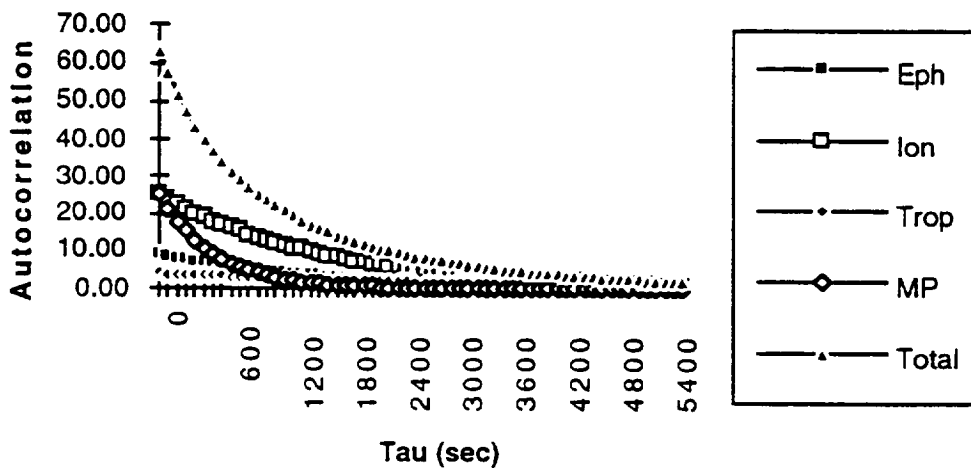
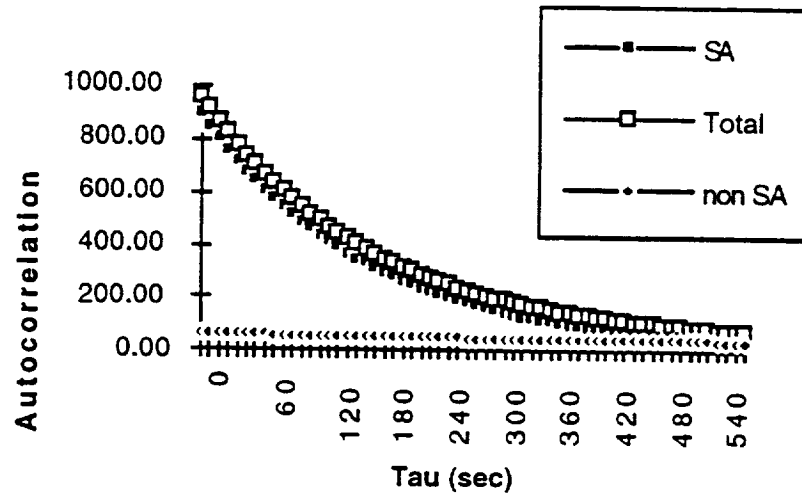


Figure 1. Autocorrelation of C/A code noise parameters (except Selective Availability)



2. Autocorrelation of C/A code noise including Selective Availability

Figure

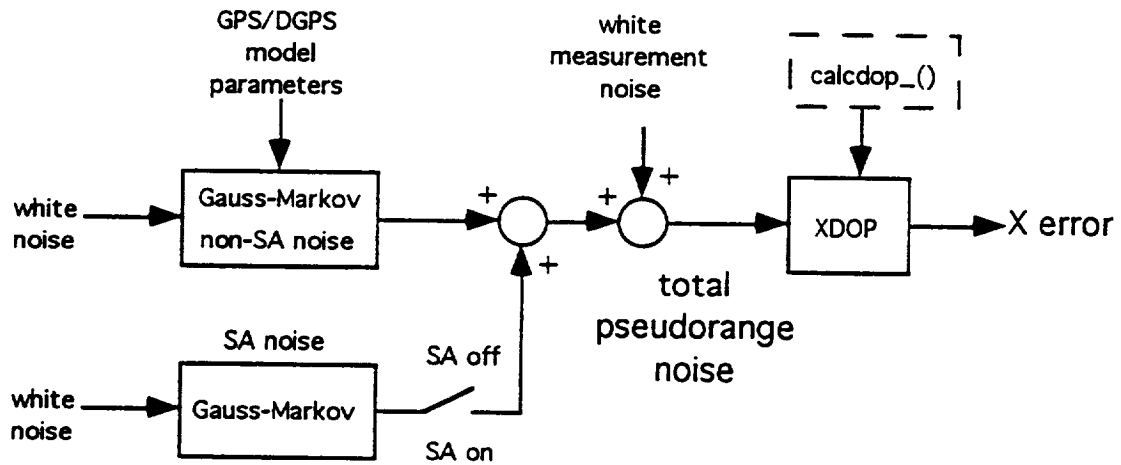


Figure 3. GPS error algorithm for X-axis. (Y and Z axis are similar)

	Average	Minimum	Maximum
XDOP	0.7	0.5	0.9
YDOP	0.8	0.5	1.6
VDOP	1.1	0.7	1.8
HDOP	1.6	1.0	2.9
GDOP	2.1	1.4	4.1

Table 3. DOP values at Denver Stapleton airport. Calculated every ten seconds for one day.

GPS/DGPS RECEIVERS	SA off	SA on
GPS - C/A code wide correlator	27.2	99.8
GPS - C/A code narrow correlator	19.7	98.0
GPS - C/A code & carrier phase	13.9	97.0
GPS - P code	12.0	96.7
DGPS - C/A code wide correlator	-	18.7
DGPS - C/A code narrow correlator	-	1.2
DGPS - P code	-	3.4
DGPS - C/A code & carrier phase	-	0.2

Table 4. Horizontal accuracy for GPS/DGPS receivers ( 95% ) (HDOP=1.6)

**AERODYNAMIC HEATING IN HYPERSONIC FLOWS**

**By  
C. Subba Reddy  
Engineering Technology Dept.  
Virginia State University  
Petersburg, VA 23806**

**ABSTRACT**

**Aerodynamic heating in hypersonic space vehicles is an important factor to be considered in their design. Therefore the designers of such vehicles need reliable heat transfer data in this respect for a successful design. Such data is usually produced by testing the models of hypersonic surfaces in wind tunnels. Most of the hypersonic test facilities at present are conventional blow-down tunnels whose run times are of the order of several seconds. The surface temperatures on such models are obtained using standard techniques such as thin-film resistance gages, thin-skin transient calorimeter gages and coaxial thermocouple or video acquisition systems such as phosphor thermography and infrared thermography. The data so collected is usually reduced assuming that the model behaves like a semi-infinite solid (SIS) with constant properties and heat transfer is by one-dimensional conduction only. This simplifying assumption may be valid in cases where models are thick, run-times short and thermal diffusivities small. In many instances, however, when these conditions are not met, the assumption may lead to significant errors in the heat transfer results. The purpose of the present paper is to investigate this aspect. Specifically, the objectives are: (1) to determine the limiting conditions under which a model can be considered a semi-infinite body, (2) to estimate the extent of errors involved in the reduction of the data if the models violate the assumption, and (3) to come up with correlation factors which when multiplied by the results obtained under the SIS assumption will provide the results under the actual conditions.**

**To achieve the above goals, the transient one-dimensional conduction equation in a semi-infinite medium with a convective boundary is analytically solved and temperature history graph is produced. From this graph, the minimum thickness of the model for which it can be considered SIS for a given run-time or vice versa is determined. This is done by arbitrarily assuming that the model behaves like SIS if the rise of the temperature ( from the initial uniform temperature) on the back side of the model is less than one percent of the rise on the front (heating) side of the model. From this limiting condition, a plot of critical thickness versus critical run-time is generated for a given material and wind tunnel conditions. This curve would be useful in designing test models and run-times such that the SIS premise is not violated. Conversely, if the model thickness and material, run-time and wind tunnel conditions are known, the percent deviation from the ideal conditions can determined.**

**In order to account for the finite size of the model under actual conditions, the one-dimensional transient heat conduction problem in a finite slab with one side subjected to convective boundary and other insulated is analytically solved. The results are compared to the solution obtained under the ideal conditions; the difference in the heat transfer results is correlated to the percent deviation of the model from the ideal conditions, and the correction factors are developed. These factors are expected to be valuable tools to experimental researcher in estimating realistic aerodynamic heat transfer coefficients and heating rates under the actual conditions and applying them with confidence in designing hypersonic vehicles.**

Aeronautical Engineering as a Context for a Course in Mathematics

by

George Rublein

Department of Mathematics

College of William and Mary

Williamsburg, VA 23185

During the tenure of this fellowship, the author began the development of a highly non-traditional approach for a mathematics course intended for undergraduates who are non-science concentrators.

At many institutions, these students are compelled, for one reason or another, to take a course in mathematics. Such a student who is at once mathematically ambitious and capable will sometimes take a course in beginning calculus. Others less well endowed find minimal methods of satisfying the requirement.

Typical examples are high school level course in trigonometry or algebra. Perhaps a statistics course of some sort, or a so-called finite mathematics course. It is a well-established fact that the majority of students who emerge from such courses are left with a bad taste in their mouths.

The author has undertaken another approach akin to the version of mathematics that working engineers use. Their perception of mathematics is, in the main, an entirely pragmatic one. For an engineer, mathematics is not organized by the unifying characteristics that are the framework of mathematicians. An engineer uses enough of a technique to solve a problem and then the technique is left until needed for the next problem.

It is not the contention of the author that mathematics for professional engineers should be taught in the fragmented way it is actually used. The efficiency and unity of the discipline that are ingrained in every mathematician are most likely the best guides for conveying serious mathematics to serious users. There are simply too many applications of mathematics to trust it to an exposition by example.

But only the rare non-science student is a serious user. This means that while individual topics in a terminal mathematics course are supplied with 'realistic' applications, there is no useable motivation for the entire undertaking. Thus does the student conspire with the instructor: I am taking this course because I have to, I will never use it, and I don't understand how anybody else uses it.

Indeed, this a view taken by many students already in high-school. One potential consumer for the course under design is the prospective middle school teacher. As undergraduates, these students are unlikely to get any sense of the role of mathematics in the



modern world. They are trained in their college course(s) that mathematics is one topic after another in the text book. And that is the way they teach *their* pupils in school, with catastrophic results for those who need to take mathematics in high-school.

That part of the material developed so far is still in draft stage. The working idea is to display some obvious, though perhaps mysterious, aspect of powered flight, and then expose a mathematical technique that might be used to help understand the problem. True to the code, any such technique is developed only so far as it is needed. There is no formalism, only an attempt to show students that working things out on paper is cheaper than a multitude of experiments.

In the end, the author expects to construct a text that is not beginning physics and certainly not beginning aeronautical engineering. No problem is undertaken unless it is both obvious and contains some mathematics that is accessible to intelligent though untrained students.

To date, we have worked out, or partially worked out the following topics.

1. Cross winds, parallelogram addition and vector decomposition.
2. Navigational headings, compass arithmetic. Polar coordinates.
3. Moments, center of gravity, requiring in messy cases some numerical integration.
4. Combining compasses on the surface of the earth. Map projections, geometry. Great circles as distinguished from navigational headings.
5. Wind distributions. Optimal orientation of runways. More numerical integration.

It remains to open the dynamical can of worms. This is obviously going to be very difficult. But there is a lovely lesson: mathematicians and engineers do not know everything they would like to know about fluid flow.

It is the author's belief that powered flight, as a physical phenomenon, remains a great mystery to most lay people. It is actually a great mystery to most mathematicians. If one could succeed in exposing something of this mystery and also exposing the usefulness of mathematics in that context, a good course in mathematics may result.

**Development of Methodologies for the Estimation  
of Thermal Properties Associated with Aerospace Vehicles**

by

Professor Elaine P. Scott  
Department of Mechanical Engineering  
Virginia Polytechnic Institute and State University  
Blacksburg, VA 24061-0238

**ABSTRACT**

Thermal stress analyses are an important aspect in the development of aerospace vehicles such as the National Aero-Space Plane (NASP) and the High-Speed Civil Transport (HSCT) at the National Aeronautics and Space Administration Langley Research Center (NASA-LaRC). These analyses require knowledge of the temperature within the structures which consequently necessitates the need for thermal property data. The initial goal of this research effort was to develop a methodology for the estimation of thermal properties of aerospace structural materials at room temperature and to develop a procedure to optimize the estimation process. This estimation procedure was implemented utilizing a general purpose finite element code. In addition, an optimization procedure was developed and implemented to determine critical experimental parameters to optimize the estimation procedure. Finally, preliminary experiments were conducted at the Aircraft Structures Branch (ASB) laboratory.

**INTRODUCTION**

Researchers within the ASB at NASA-LaRC are currently investigating the thermal stresses associated with aerospace structures. In these studies, the temperature distribution within the material must be known, and it can be determined using a mathematical model of the system which in turn requires knowledge of the thermal properties of the structural materials. Many of these properties are unknown and/or difficult to determine, and important considerations, such as anisotropic behavior, complex geometries, and extreme temperature ranges, must be taken into account.

The strategy used for this investigation was to start with a simple problem and increase its complexity incrementally. Therefore, the initial objective was to develop a methodology for the estimation of the thermal properties of isotropic materials at room temperature and to design optimal experiments to determine these properties. The research plan involved the utilization of a general purpose finite element code currently used by the ASB, called EAL<sup>1</sup>, in the estimation procedure, the design of in-house experimentation at the ASB laboratory, and the provision for flexibility and adaptability to allow for future evaluation of complex materials and structures over extreme temperature ranges. The primary significance of this work is that it enables accurate thermal modelling which can later be used for thermal stress analysis. In addition, the methodology utilized permits the design of optimal experiments for the estimation of thermal properties, and provides LaRC researchers greater flexibility and time efficiency

through the adaptability of the procedure and the development of in-house experiments. Furthermore, the methodologies developed as a result of this research can also be utilized in the development of estimation procedures for the determination of structural properties.

### ESTIMATION PROCEDURE

The estimation procedure is based on the minimization of an objective function which contains experimental and calculated temperature data with respect to the unknown thermal properties. The objective function was simply defined as a least squares function which contains the difference between calculated and measured temperatures. The minimization procedure used was based on the Gauss minimization method, which was modified using the Box-Kanemasu Modification<sup>2</sup>. Inherent in the minimization procedure are sensitivity coefficients which are the derivatives of temperature with respect to changes in the property under consideration. The calculated temperatures were obtained from a mathematical model of the system. In this model, one-dimensional heat transfer was assumed with known temperature and heat flux boundary conditions. The resulting temperature distribution was calculated using EAL.

### EXPERIMENTAL DESIGN AND OPTIMIZATION

A simple geometry using flat plate samples was chosen for the experimental design. A thin resistance heater was used to supply the heat flux boundary condition. To ensure symmetry, the heater was sandwiched between two composite samples of equal thickness. Thermocouples were placed on either side on the heater to measure temperature, and the composite sandwich was placed between two copper blocks with thermocouples on either side of the samples. The copper blocks were used to approximate a constant temperature boundary condition. The entire assembly was held together in a simple press and placed in a uniform temperature oven. A schematic of the experimental setup is shown in Figure 1.

Prior to implementation of the experimental procedure, the experimental parameters, including the total experimental time, the heating time and the sensor location, were determined using an optimization procedure which maximized the sensitivity of temperature to changes in the thermal properties. The optimal parameters were obtained by maximizing the determinant of a matrix containing the product of time averaged sensitivity coefficients.

### RESULTS AND DISCUSSION

The estimation procedure was developed using EAL. Initially, simulated experimental data with and without added random errors were used to test the procedure. The experimental optimization procedure was then implemented, and the results for the determination of the optimal heating time and sensor location are shown in Figures 2 and 3, respectively. Finally, preliminary experiments were conducted using 5260/IM7 composite samples. Future work will include the analysis of the experimental data using the estimation procedure for the estimation of the thermal properties, and the modification of the procedure to estimate anisotropic thermal properties over extreme temperature ranges.

### REFERENCES

1. Whetstone, W.D., 1983, EISI-EAL Engineering Analysis Language, Engineering Information Systems, Inc., San Jose, CA.
2. Beck, J.V., and Arnold, K.J., 1977, Parameter Estimation in Engineering and Science, John Wiley and Sons, NY.

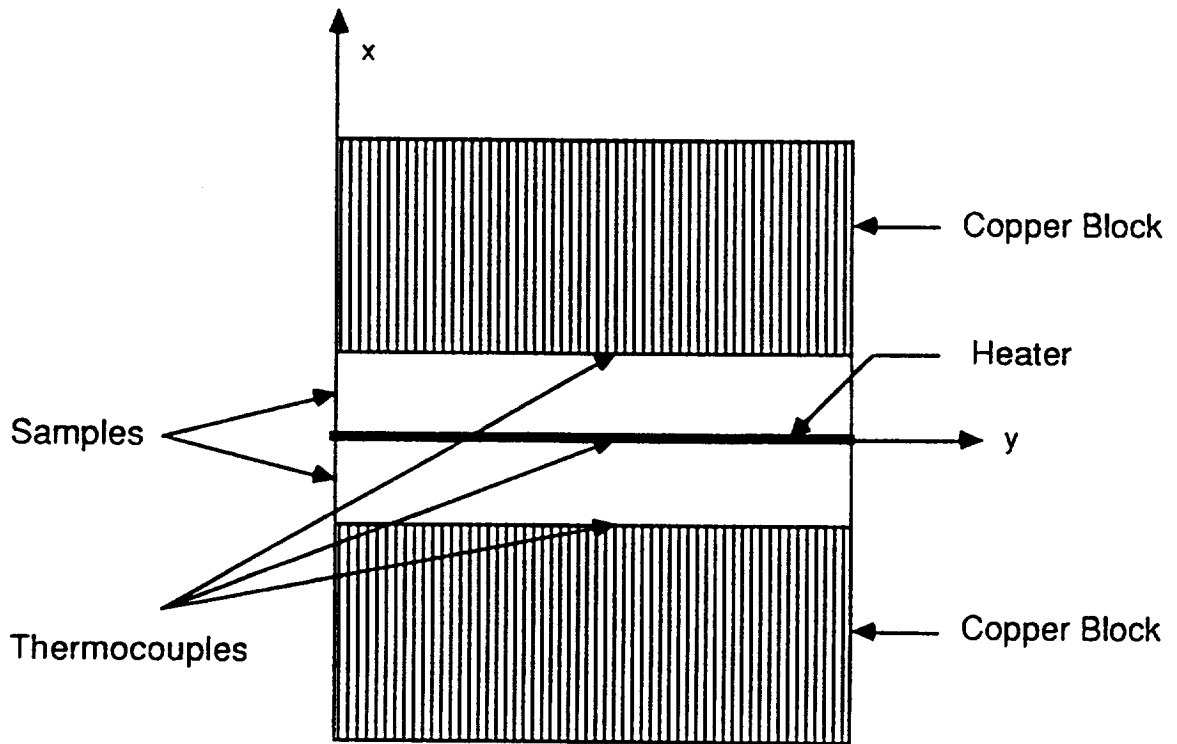


Figure 1. Experimental Set-up.

Determinant,  $D$ , for Various Heating Times  
( $x^+ = 0.0$ )

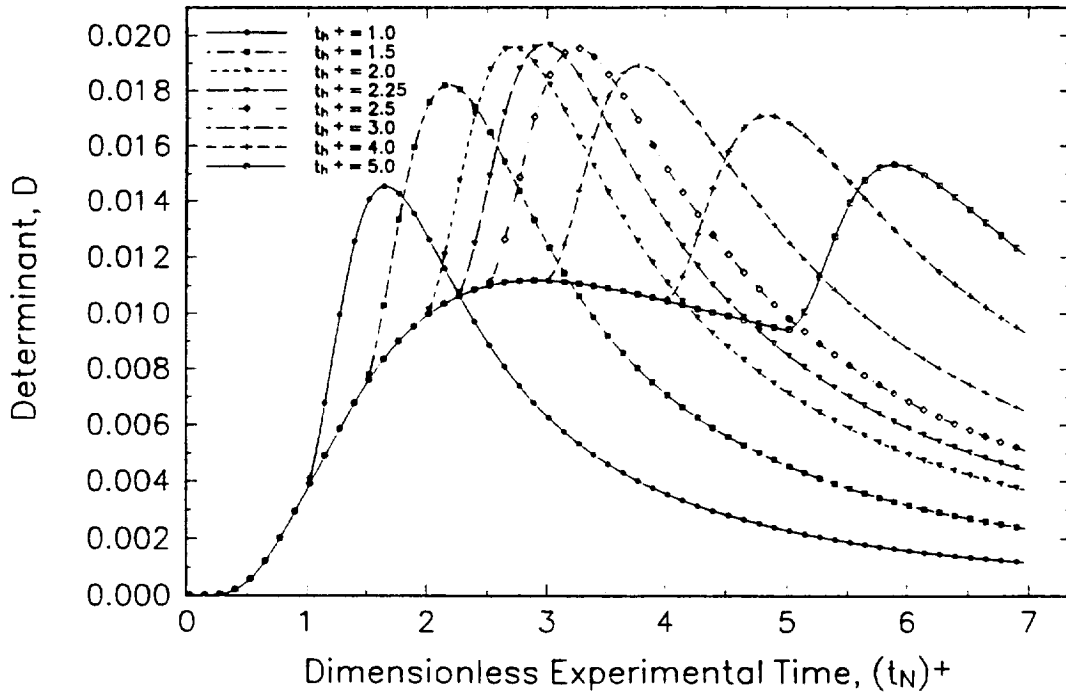


Figure 2. Determination of Optimal Heating Time,  $t_h^+$  ( $\alpha t/L^2$ ;  $\alpha$  = thermal diffusivity,  $t$  = time,  $L$  = sample thickness), from the Maximum Determinant,  $D_{max}$ .

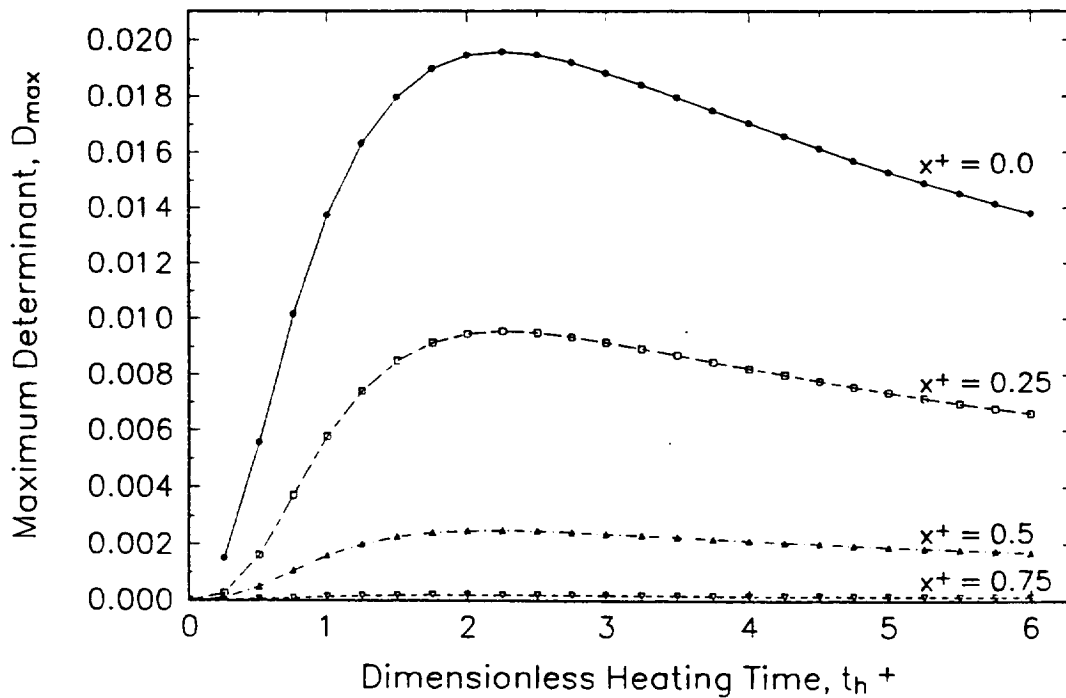


Figure 3. Determination of Optimal Sensor Location,  $x^+$  ( $x/L$ ;  $x$  = sensor location,  $L$  = sample thickness), from the Maximum Determinant,  $D_{max}$ .

# **Evaluation of High Temperature Superconductive Thermal Bridges for Space-Borne Cryogenic Infrared Detectors**

by

Professor Elaine P. Scott  
Department of Mechanical Engineering  
Virginia Polytechnic Institute and State University  
Blacksburg, VA 24061-0238

## **ABSTRACT**

The focus of this research is on the reduction of the refrigeration requirements for infrared sensors operating in space through the use of high temperature superconductive (HTS) materials as electronic leads between the cooled sensors and the relatively warmer data acquisition components. Specifically, this initial study was directed towards the design of an experiment to quantify the thermal performance of these materials in the space environment. First, an intensive review of relevant literature was undertaken, and then design requirements were formulated. From this background information, a preliminary experimental design was developed. Additional studies will involve a thermal analysis of the experiment and further modifications of the experimental design.

## **INTRODUCTION**

Infrared sensors are currently being used to monitor the concentration of various chemical radicals in the upper atmosphere in an overall effort to study the condition of and changes in the earth's environment. Liquid helium cryogenic refrigeration systems are used to provide cooling for the sensors, and consequently, cryogenic evaporation is the primary limiting factor in the lifetime of these satellite systems. One area in which thermal losses can be reduced is within the electrical connections between the cryogenically cooled infrared sensors and the relatively warmer data acquisition system.

This study is focused on the use of high temperature superconductive (HTS) electronic leads in place of the commonly used manganin leads as a means of reducing the refrigeration load. The overall goal of this ongoing research effort is to quantitatively compare the thermal performance of HTS materials with manganin wires for use in space. The initial objective was to develop a preliminary experimental design which satisfies the primary requirements for the experiment. The research strategy was to design an experiment which allowed for the direct comparison of the cooling requirements of the HTS and the manganin leads and also allowed for the determination of the thermal conductivity of the HTS material in the space environment.

The research plan for these initial studies first involved an intensive review of relevant literature, and in addition, the finite element software to be used in future thermal analysis of the experimental design was determined and studied. This background information was then used to formulate a list of requirements and constraints for the proposed experiment. Commercial vendors were then contacted to

determine the feasibility of certain design components and the availability of equipment items. Finally, based on requirements and constraints and on commercial vendors' recommendations, a preliminary experimental design was formulated.

### EXPERIMENTAL REQUIREMENTS AND CONSTRAINTS

Based on the stated objectives and relevant background information, the experimental requirements include 1) identical systems for the HTS materials and the manganin wires, 2) thermal isolation of these systems, 3) minimum non-conductive heat losses, 4) maximum and minimum source temperatures at approximately 80K and 4K, 5) isolated measurement of refrigerant consumption at cold tips for each system, 6) structural supports to withstand vibrational loads during launching, 7) a minimum of 100 detector leads to simulate the electrical requirements of typical infrared detectors, 8) 6" long leads, and 9) a measurable heat flux at the warmer temperature source to determine thermal conductivity. Some of the design objectives are limited by the constraints of the spaceflight mission. These constraints include 1) payload size, 2) available power and current, 3) weight constraints, 4) maximum vibrational loads during lift-off, 5) mission lifetime, and 7) experimental budget.

### PRELIMINARY EXPERIMENTAL DESIGN

The preliminary experimental plan is shown in Figure 1. It features three identical systems differing only in the electronic lead material. Two of these systems are comprised of two different types of superconductor/substrate combinations and the other system is composed of manganin wires. As indicated in Detail B, each of the three test materials is clamped between three identical cold tips at 4K, while a heating element is used at the other end to supply a heat flux condition at approximately 80K. Temperature sensors are located along the test materials and at each end. A single cryogenic cooler equipped with three cold tips is used to supply the refrigeration effect. A single dewar system with three separate flow meters to the three cold tips will allow for the measurement of the required heat flow for each test sample. The three test samples are encased in a single vacuum environment to minimize convective losses. To reduce vibrational problems, an ionic vacuum pump will be used. Radiation losses and interactions will be minimized through the use of separate radiation shields around each sample. Finally, structural supports (not shown), made from a material such as a fiberglass composite, are to be included.

The electronic leads will consist of 100 individual leads for each type of material. In the case of the manganin leads, 40 AWG wires encased in a thin layer of Kapton will be used. The HTS materials will be printed on one side of the substrate material, as shown in Figure 2.

### FUTURE STUDIES

Continuation of this work will include the development and analysis of a thermal model of the experimental design, the identification of sources for the experimental components, an analysis of the support requirements for the test leads, and the modification of the design as warranted with the acquisition of new information. The completion of the design is targeted towards a 1996 Space Shuttle mission.

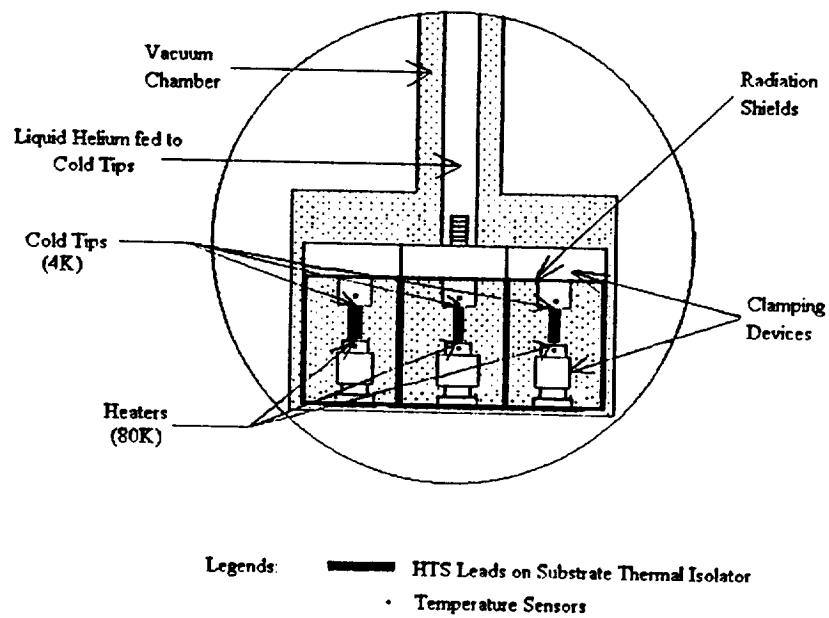
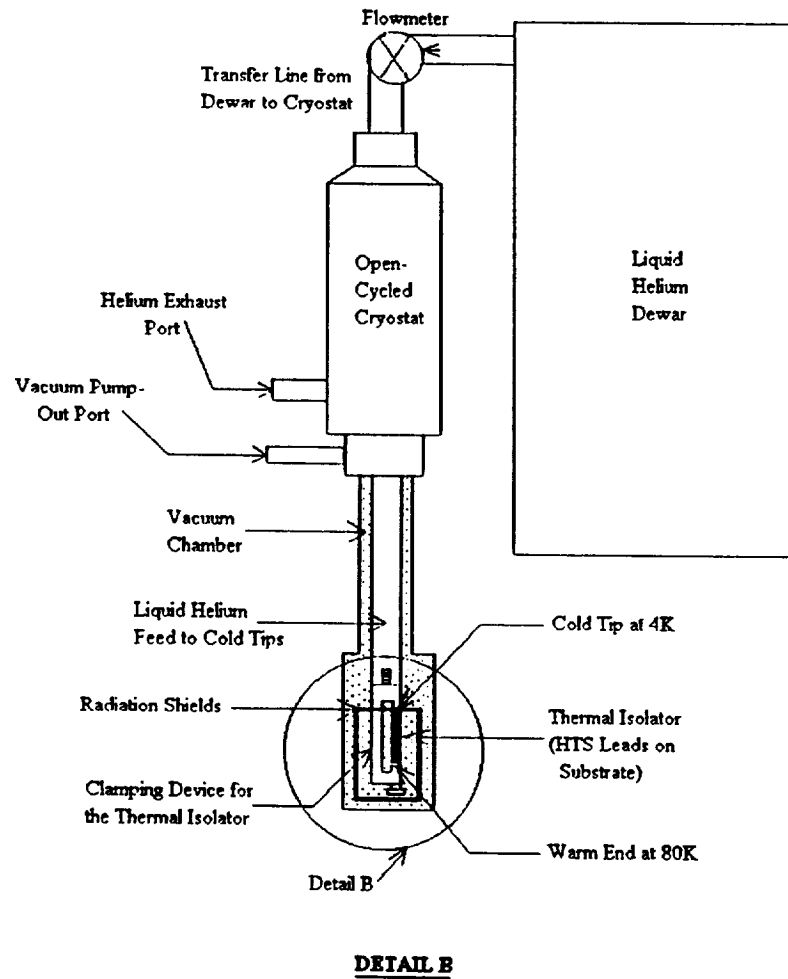
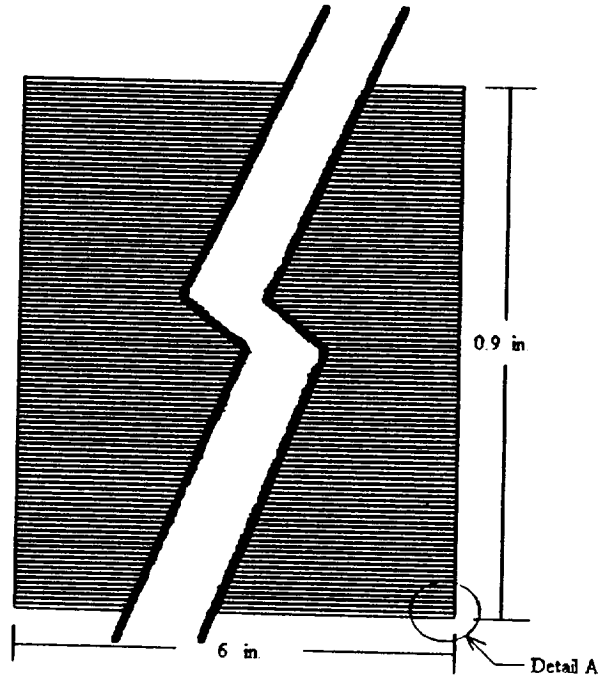




Figure 1. Preliminary Design of Experiment for the Thermal Comparison of Electronic Lead Materials



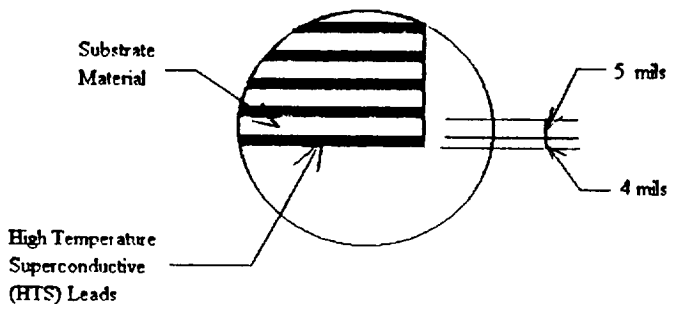


Legend:  High Temperature Superconducting Leads  
 Substrate Material

Notes: 1. Not to Scale  
 2. 100 HTS leads are printed on a substrate (6.0 in. x 0.9 in).

Detail A

Top View



Profile View

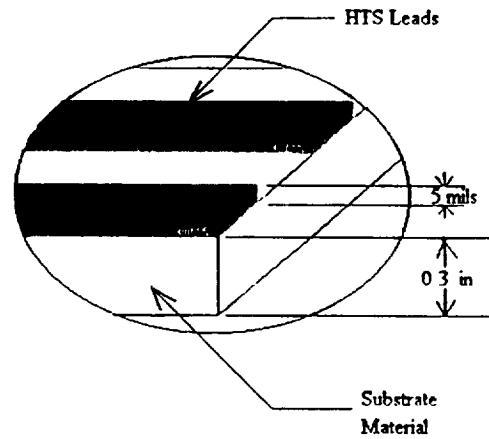


Figure 2. High Temperature Superconductive Leads Printed on the Substrate

# ORGANIZATIONAL DEVELOPMENT: A PLANNED CHANGE EFFORT IN THE MANAGEMENT SUPPORT DIVISION AT NASA LANGLEY RESEARCH CENTER

by

Professor Denise V. Siegfeldt  
School of Business, Tidewater Graduate Center  
Florida Institute of Technology  
Fort Eustis, VA 23604

(Prepared in collaboration with Howard R. Puckett, Jr., Assistant Chief, Management Support Division, NASA Langley Research Center)

## ABSTRACT

This abstract describes an organizational development project which was initiated at NASA Langley Research Center in the Management Support Division (MSD). Organization development (OD) is a planned change effort which involves "the application of a *system approach* to the functional, structural, technical, and personal relationships in an organization."<sup>1</sup> The purpose of the project was to identify key problems that existed in the Division, to develop feasible solutions to the problems, to implement these solutions, and ultimately, to improve "the effectiveness of the organization and its members."<sup>2</sup>

MSD consists of a Division Office, and three Branches: Logistics Management, Security Services, and Institutional Support (see Figure 1). The MSD currently employs 50 civil servants and is supported by 160 man years of effort under its current contractor, Mason & Hanger Services, Inc. The MSD civil servants and contractors are housed in 17 different buildings throughout the Center, which has reportedly contributed to a breakdown in communication. This OD effort was limited to the 50 MSD civil servants. Over the past 4 months, major changes have taken place within MSD, including retirements, promotions, transfers, and temporary details.

The OD planned change effort was based upon the action research model, which consists of eight major steps.<sup>3</sup> "Action research involves collecting information about the organization, feeding this information back to the client system, and developing and implementing action programs to improve system performance."<sup>4</sup>

Initially, this researcher met with the MSD Chief and Assistant Chief to determine their goals for the OD effort, visited various MSD offices, and became familiar with the organization's structure, functions, leadership, employees, and culture. These management officials provided visible support for the OD effort, which greatly enhanced the success of the project. An MSD Organizational Assessment Questionnaire (OAQ) consisting of five open-ended questions (see Figure 2) was subsequently developed and administered to each of the MSD civil servants to gather information needed to diagnose the organizational functioning of the Division. The employees were requested to respond anonymously to the questions.

Twenty-four MSD employees returned their completed OAQ's, yielding a 48 percent rate of return. Narrative comments from the completed OAQ's were compiled for each question, and major themes were derived. The survey was effective in eliciting employee perceptions and attitudes toward their jobs, leaders and supervisors, co-workers, opportunities for advancement, rewards and recognition, work environment, equipment, communications, morale, motivation, training, staffing, funding, and organizational structure. Due to space limitations, only the key findings of the MSD OAQ's will be reported.

MSD OAQ results revealed that the work itself was the most preferred aspect of working in MSD, followed by the employees within the Division, and supervision/leadership mentioned third. Lack of communication, and supervision/leadership were equally cited as being the least preferred aspects of working in MSD, followed by organizational structure. The discrepancy in viewpoints on supervision/leadership could be largely attributed to the fact that MSD employees report to different Branch managers or supervisors. Poor funding and lack of training were viewed as the greatest job impediments. The perceived lack of training was frequently attributed to poor funding, especially for travel. Employees cited increased funding and improved communications within MSD as the two major areas where improvements could be made to help them perform their jobs more effectively, and to increase their job satisfaction. Additional areas cited included leadership, work, attitudes, rewards, and teamwork. Seven of the 24 OAQ respondents provided additional comments on the OAQ for question number 5, with the most frequent comments pertaining to leadership, employee morale/motivation, comments about the survey, and communication.

Each employee was provided with a copy of the narrative comments that were compiled from the completed MSD OAQ's, and a Follow-Up MSD Organizational Assessment Questionnaire (OAQ) to answer (see Figure 3). The purpose of the Follow-Up OAQ was to elicit feedback on the original MSD OAQ responses. There was a 30 percent response rate on the second questionnaire. Employees generally agreed that the OAQ responses were accurate, although some indicated that they were not necessarily true for the entire organization. Perceptions that were noted by employees which were not covered in the original OAQ results typically involved comments about the survey, or survey expectations. The overwhelming majority of the respondents indicated that lack of communication was the "number one" problem in MSD. Additional problems noted in the Follow-Up OAQ included poor morale, lack of confidentiality, favoritism, inadequate staff, and insufficient funding. Employees provided solutions for some of the problems, particularly communication. Communication breakdowns are often "a precipitant factor behind many other problems,"<sup>5</sup> such as poor morale.

In keeping with the intent of the Total Quality Management effort at the Center, a Quality Action Team consisting of eight volunteers was formed. The team was established to help identify the two or three major problems to address in MSD, based on OAQ results; to identify and analyze root causes; and to develop a course of action for resolving, or at least improving, these problems. Spin-off benefits from team participation, such as bolstered employee morale, enhanced competence, and increased motivation, are expected.<sup>6</sup> Two meetings have been held to date, and additional meetings are scheduled until the action plan is finalized and submitted by the team. This researcher will return to MSD throughout the year to assist the team, implement OD interventions that are needed, and develop a proposal to evaluate the outcome and impact of the change effort 1 year from now. Additional interventions may be implemented following the evaluation procedure.

## References

<sup>1</sup>Donald F. Harvey, and Donald R. Brown, *An Experiential Approach to Organizational Development*, 4th ed. (Englewood Cliffs, NJ: Prentice Hall, 1992), 59.

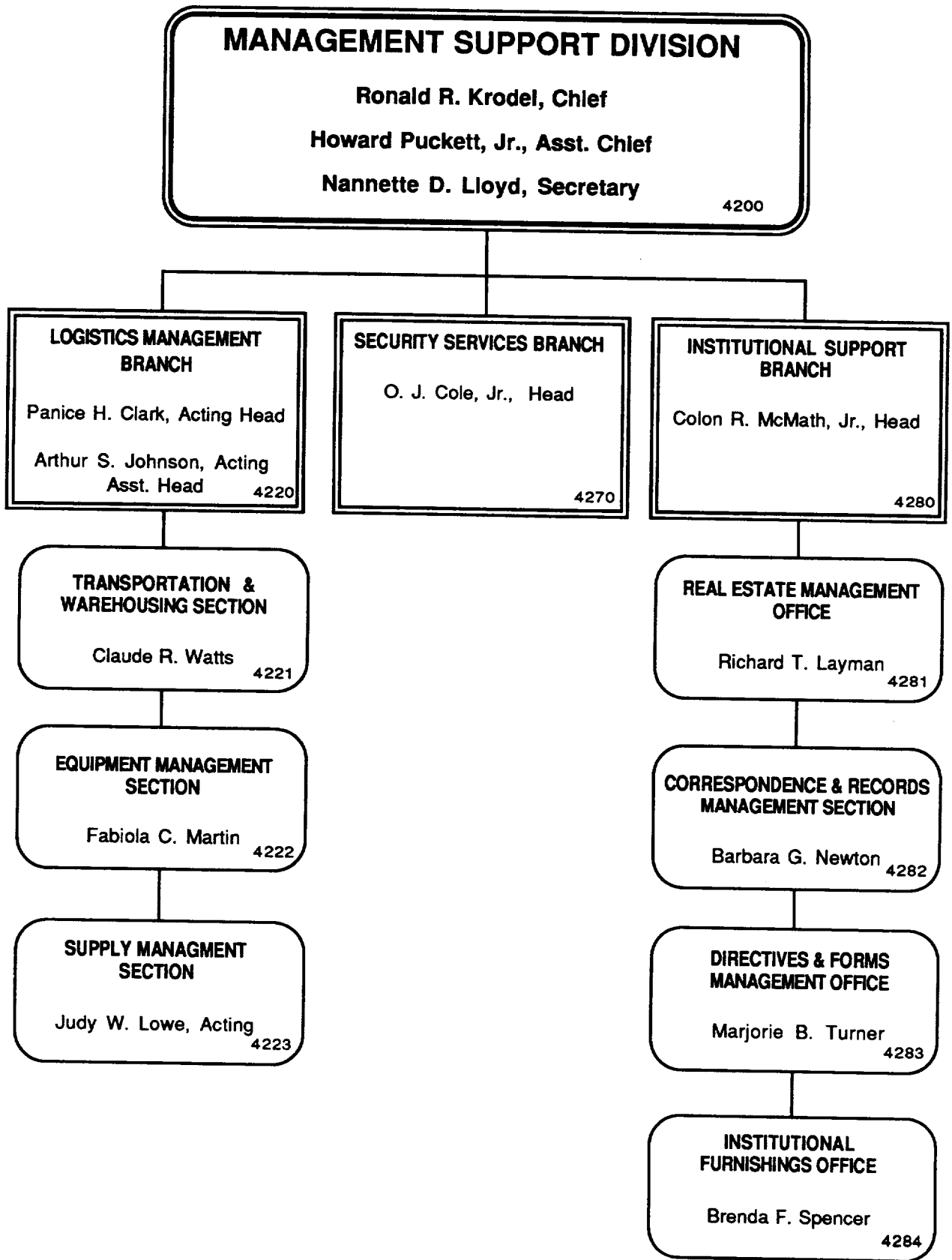
<sup>2</sup>*Ibid.*, 5.

<sup>3</sup>Thomas G. Cummings, and Edgar Huse, *Organizational Development and Change*, 4th ed. (St. Paul, MN: West Publishing, 1989), 48.

<sup>4</sup>Harvey, *An Experiential Approach*, 60-61.

<sup>5</sup>Kenneth R. Gilberg, "Open Communications Provide Key to Good Employee Relations," *Supervision* 54 (April): 8-9.

<sup>6</sup>Henry L. Lefevre, *Quality Service Pays: Six Keys to Success* (Milwaukee, WI: Quality Press, 1989), 294.



8/5/93

Figure 1

**MSD Organizational Assessment Questionnaire (OAQ)**

1. What do you like most about working in the Management Support Division?
2. What do you like least about working in the Management Support Division, and why?
3. What do you see as the greatest impediment in preventing you from performing your job as well as you would like?
4. What do you believe can be done within the system to help make you a more satisfied employee?
5. Are there any additional comments that you would like to make?

**Figure 2**

**Follow-Up MSD Organizational Assessment Questionnaire (OAQ)**

1. Are the comments an accurate reflection of the employee perceptions concerning the Management Support Division?
2. Identify and elaborate on any perceptions that you have, both positive and negative, which are not covered in the comments.
3. What do you feel is the "number one" problem in the Management Support Division? What solution(s) do you propose for the problem?

**Figure 3**

A Tri-State Optical Switch for Local Area  
Network Communications

Garfield Simms, Assistant professor  
Hampton University, Department of Mathematics  
Hampton, Virginia

**Abstract:** This novel structure is a heterojunction phototransistor which can be used as an emitter-detector, and when placed in a quiescent mode, the device becomes a passive transmitter. By varying the voltage bias, this novel device will switch between all three modes of operation. Such a device has broad application in network environments with operation speeds of less than 50MHz and distances of less than 1km, e.g. automobiles, airplanes, and intra-instrumentation [7]. During this period, the emission mode for this device was studied and mathematically modeled.

**Introduction**

Shown in Fig. 1, the device is a heterojunction phototransistor. It consists of four epitaxial layers grown on a semiconducting substrate. A buffer can be grown to insure layer quality. Essentially, this device has a bipolar transistor configuration in which region (A) contains the emitter, region (B) is the base, and region (C) is the collector.

Typically, emission and detection are not embodied in the same device because of low detection response. Therefore, a key feature to the implementation of this structure is the Franz-Keldysh effect [3,7]. By placing a high electric field across the depletion width, approximately  $10^4$  V/cm, a small shift in the absorption edge occurs as shown in Fig. 2. Because of the absorption characteristics in GaAs, a small shift induces a large change in the absorption coefficient. Thus, by modulating an applied voltage to the device, the absorption coefficient is increased or decreased. Thereby, the device is altered from a detecting state to a passive state. (A slight pre-bias may be applied to improve the switching times.)

The emission mode of the device occurs by placing a forward bias across the emitter junction. The resulting emission characteristics are shown in Fig. 3. In general, the emission pattern is non-coherent and is characterized as Lambertian. A portion of the light is transmitted perpendicularly through the top of the device, and other components are confined and transmitted laterally towards the edges of the device. The following is a mathematical model for that emission.

**Mathematical Description**

The method of analysis used was similar to that for a cylindrical waveguide with an active cladding [2,5,8]. The similarities exist in that both have a Lambertian source distribution within the waveguide. Also, light can undergo total internal reflection and be transmitted laterally through the waveguide as shown in Fig. 4. As a result, Maxwell's equations will include a source term ( $J$ ) which significantly complicates their solutions.

The two main equations are

$$\nabla \times E = i \sqrt{\frac{\mu_0}{\epsilon_0}} k H \quad (1)$$

$$\nabla \times H = J - i \sqrt{\frac{\epsilon_0}{\mu_0}} k n^2 H \quad (2)$$

and for an unpolarized source in a non-magnetic material

$$\mathbf{J} = \sigma \mathbf{E} \quad (3)$$

where  $\sigma$  is the conductivity,  $k$  is the wavenumber, and  $n$  is the index of refraction. Also, we can assume that the electric field ( $\mathbf{E}$ ) and magnetic field ( $\mathbf{H}$ ) can be written as

$$\mathbf{E} = \mathbf{e}(x,y) e^{-i\beta z} e^{i\omega t} \quad (4)$$

$$\mathbf{H} = \mathbf{h}(x,y) e^{-i\beta z} e^{i\omega t} \quad (5)$$

and

$$\mathbf{e}(x,y) = \mathbf{e}_t + \mathbf{e}_z \quad (6)$$

$$\mathbf{h}(x,y) = \mathbf{h}_t + \mathbf{h}_z \quad (7)$$

where the fields can be separated into a transverse (t) and longitudinal component ( $\hat{z}$ ) [8]. We have been able to derive the  $\mathbf{e}$  and  $\mathbf{h}$  fields for the emission mode of the tri-state switch as

$$\mathbf{e}_t = \frac{\frac{i}{k} \sqrt{\frac{\epsilon_0}{\mu_0}}}{\frac{1}{k} \sqrt{\frac{\epsilon_0}{\mu_0}} (k^2 n_2^2 - \beta^2) + i\sigma} \left[ \beta \nabla_t h_z - k \sqrt{\frac{\epsilon_0}{\mu_0}} \hat{z} \times \nabla_t h_z \right] \quad (8)$$

$$\mathbf{h}_t = \frac{\frac{i}{k} \sqrt{\frac{\epsilon_0}{\mu_0}}}{\frac{1}{k} \sqrt{\frac{\epsilon_0}{\mu_0}} (k^2 n_2^2 - \beta^2) + i\sigma} \left[ \beta \nabla_t h_z + k n_2^2 \sqrt{\frac{\epsilon_0}{\mu_0}} \hat{z} \times \nabla_t e_z + i\sigma \hat{z} \times \nabla_t e_z \right] \quad (9)$$

note that both expressions are a function of only the longitudinal components. Therefore, by deriving the longitudinal expressions  $e_z$  and  $h_z$ , we can fully describe the wave propagation within the diode.

By solving the homogeneous part of Maxwell's equation [2,3,9,10]

$$\nabla^2 \mathbf{E} = -k^2 n^2 \mathbf{E} \quad (10)$$

in which  $\frac{\partial}{\partial y} \neq 0$ , we can derive a relationship for the components in the three regions of the waveguide

$$\mathbf{e}_z = \left\{ \begin{array}{ll} [C_1 \cos(\gamma y) + C_2 \sin(\gamma y)] C_6 e^{-Lx} & x \geq t_g \\ [C_1 \cos(\gamma y) + C_2 \sin(\gamma y)] (C_3 \cos(mx) + C_4 \sin(mx)) & 0 \leq x \leq t_g \\ [C_1 \cos(\gamma y) + C_2 \sin(\gamma y)] C_5 e^{Lx} & x \leq 0 \end{array} \right\} \quad (11)$$

where

$$m = \sqrt{p^2 - \gamma^2} \quad (12)$$

$$L = \sqrt{q^2 + \gamma^2} \quad (13)$$

$$p = \sqrt{k^2 n_2^2 - \beta^2} \quad (14)$$

and

$$p = \sqrt{\beta^2 - k^2 n^2} \quad (15)$$

where  $n_{\text{outer}}$  represents the index of refraction in regions (A) and (C), and  $\gamma$  is a constant related to the type of mode and mode number. (A similar expression for  $q$  is expected.) By imposing the conditions of continuity at the interface

$C_3 = C_5 = \frac{m}{L} C_4$ , and a transcendental equation in  $\beta$ , the propagation constant, is derived

$$\text{Tan}(mt_g) = \frac{2mL}{m^2 - L^2} \quad (16)$$

to which a solution has not yet been obtained.

### Conclusion

The emission mode of this novel structure has been partly modeled. A solution to the transcendental equation remains. The approach leading to this solution has not been typically used to describe semiconductor waveguides. However, in each case, the equations collapse to established forms for the source free condition [1,4,8]. Thus, by substitution of  $e_z$  and  $h_z$  into equations (8) and (9), the wave propagation within the tri-state switch is completely described.

### References

1. M. Born and E. Wolf: *Principles of Optics*. 6th ed. (Pergamon Press Inc., New York 1986).
2. C. Egalon, 'Injection Efficiency of Bound Modes'. The College of William and Mary, Williamsburg, Virginia, PhD dissertation 1990.
3. R. Hunsperger: *Integrated Optics Theory and Technology*. 3rd ed. (Springer Verlag, New York 1991).
4. P. Lorrain: *Electromagnetic Fields and Waves*. 3rd ed. (W. H. Freeman and Co., New York 1988).
5. D. Marcuse: *Theory of Dielectric Optical Waveguides*. (Academic Press, New York 1974).
6. E. Rainville: *Elementary Differential Equations*. 6th ed. (Macmillian Publishing Co., Inc., New York 1981).
7. G. Simms, 'A Broad Area Feedthrough Light Emitting Diode for Bidirectional Communication on Optical Fiber Transmission Lines'. The University of Delaware, Newark, Delaware, PhD dissertation 1992.
8. A. Snyder and J. Love: *Optical Waveguide Theory*. (Chapman and Hall, New York 1983).
9. T. Tamir: *Guided-Wave Optoelectronics*. (Springer Verlag, New York 1988).
10. A. Yariv: *Optical Electronics*. 3rd ed. (College Publishing, New York 1985).



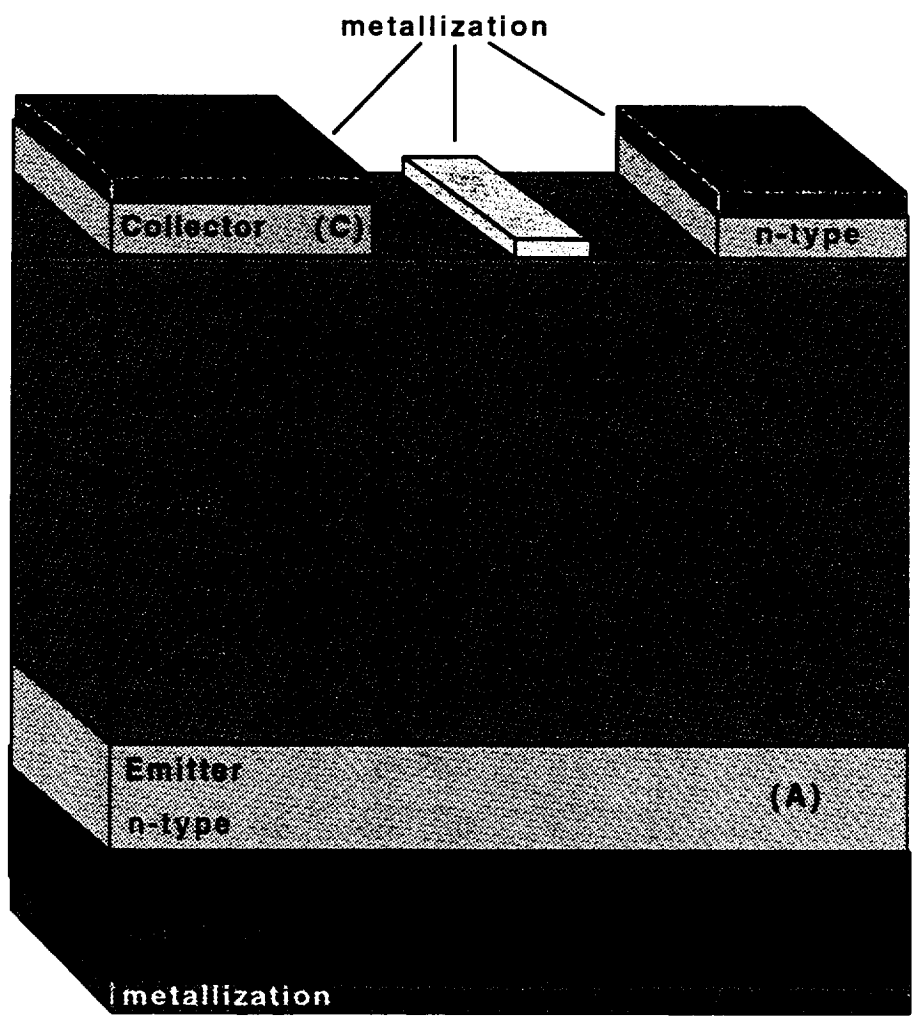


Figure 1: The tri-state optical switch. A heterojunction phototransistor consisting of four epitaxial layers. The diode is represented in a bipolar junction configuration.

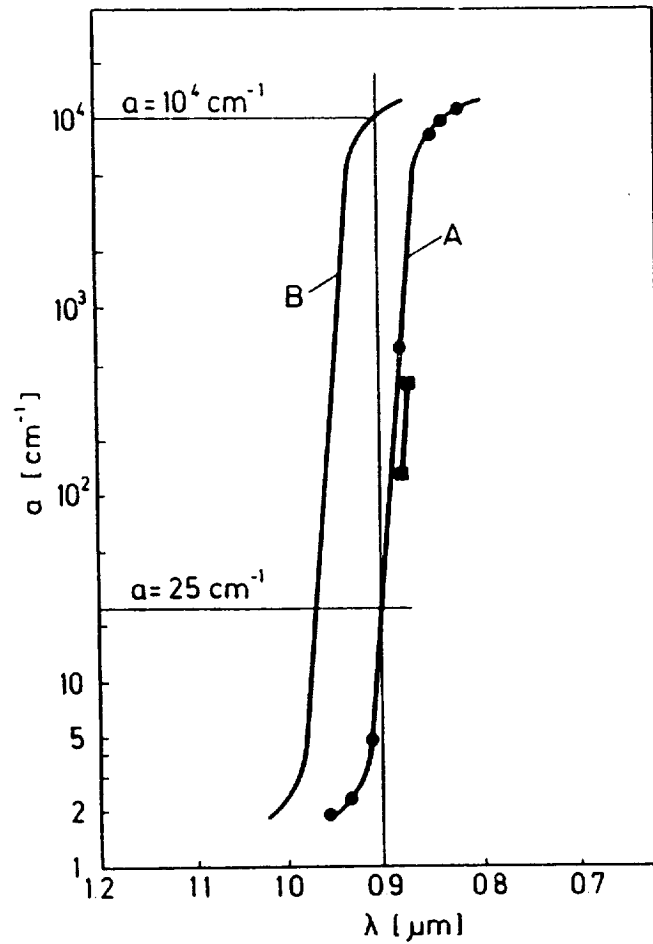


Figure 2: The Franz-Keldysh effect in GaAs. At zero bias, the absorption coefficient  $\alpha=25\text{cm}^{-1}$ . When a high electric field is applied, the absorption coefficient shifts to  $\alpha=10^4\text{cm}^{-1}$ .

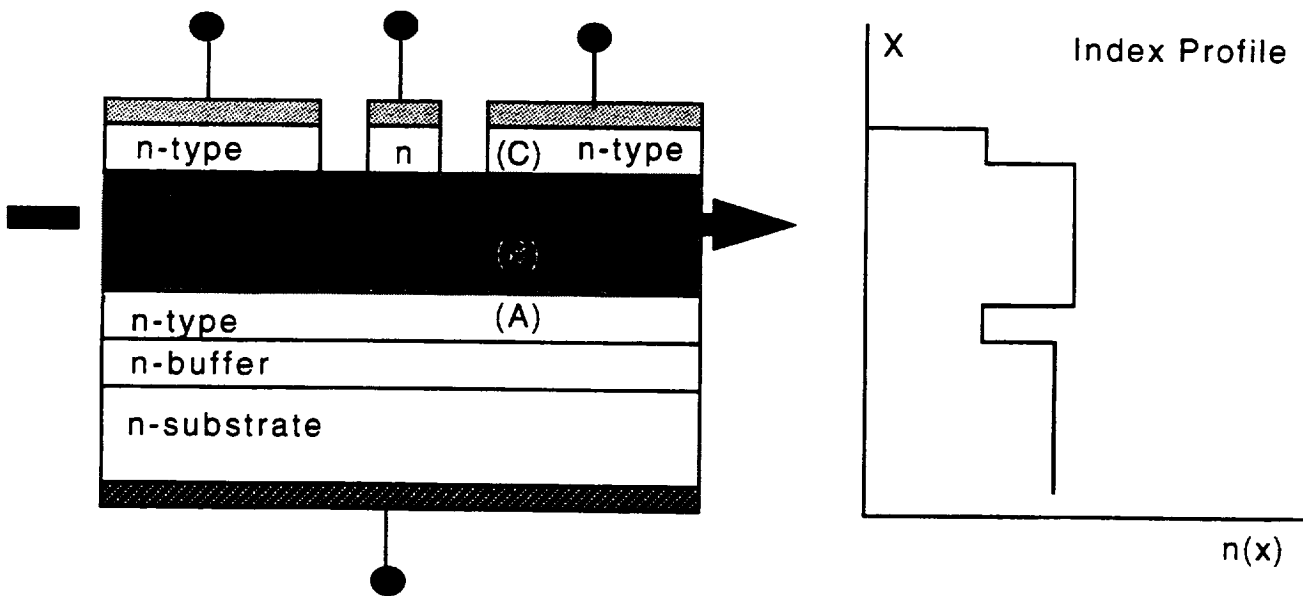
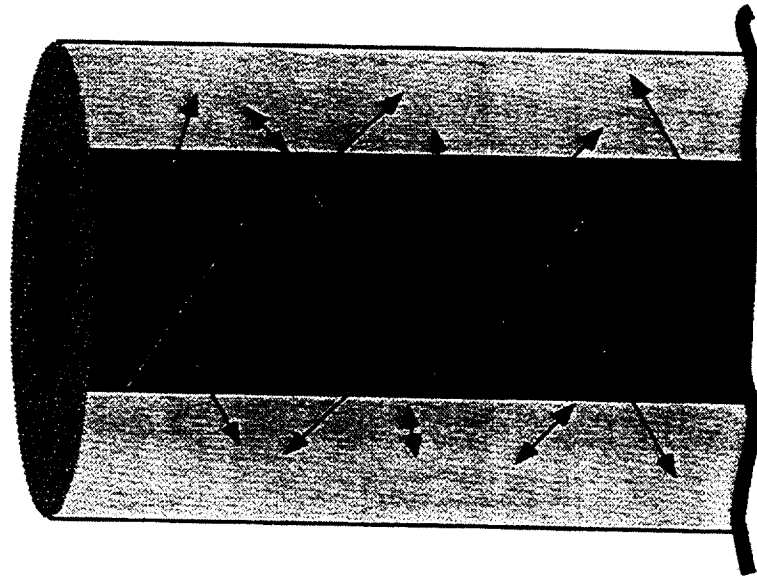
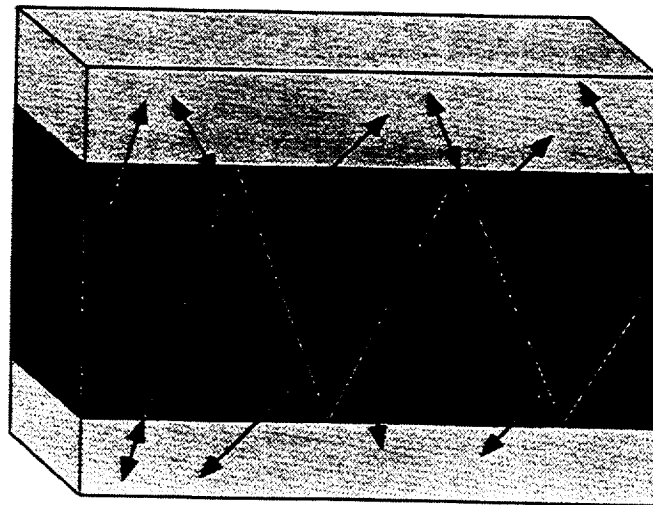


Figure 3: Shown above is the emission pattern that occurs at the emitter junction of the tri-state switch. Light is emitted equally in all directions. Some of the light is confined and channeled towards the edge of the device. The confinement is a result of the variation in the index of refraction.



(A)



(B)

Figure 4: (A) A cylindrical waveguide in which the interface/cladding region is active. Light is coupled into the core and emitted through the distal and proximal ends of the fiber. (B) A rectangular waveguide in which a source is located at one of the interfaces. Likewise, light is coupled into the core and transmitted laterally.

A STUDY OF SPACE STATION FREEDOM REDESIGN AND VARIOUS  
EARTH OBSERVING SATELLITE SYSTEMS

by  
S. Ballou Skinner, Ph.D.  
Professor of Physics  
The University of South Carolina/Coastal Carolina College  
Conway, South Carolina 29526

As a brief acknowledgment, I express my appreciation to the NASA/ASEE Summer Faculty Fellowship Program and to Dr. Roger Breckenridge, Assistant Chief of the Advanced Space Concepts Division (ASCD) for the opportunity of spending an enjoyable, productive, and rewarding summer studying Langley Research Center's (LaRC) role in the redesign of the Space Station Freedom and in the process of choosing payload and satellite configuration for various past, present, and future Earth observing missions. The NASA/ASEE Fellowship gave me access to the publication and materials from the ASCD and the LaRC Technical Library as well as to the expertise of the scientists and engineers of the Center. The information acquired in the study will be integrated into an honor course entitled "Space Exploration," which I teach at The University of South Carolina-Coastal Carolina College.

At the time of this writing, three options (A-1, B, C) and one variation on an option (A-2) have been given to President Clinton by the Space Station Redesign team. Options A-1 and C have been eliminated, while options A-2 and B are still being considered. The result may be a hybrid of options A-2 and B. Option A-2 is a modular approach given latitude to substitute for Freedom components. It is virtually identical to A-1 except that it uses Freedom components instead of Bus-1, which is an off-the-shelf Department of Defense Satellite that already is a Shuttle - quality payload capable of providing subsystems such as propulsion, electrical power, guidance, navigation and control, and communication and data management. Option A-2 draws on current space station hardware design and includes a small U. S. Laboratory along with the European and Japanese pressurized modules. It has less truss [three sections (S2, M1, P1) have been deleted] and includes a simplified electrical power system and data management system. Oxygen could be reused with the help of available Russian equipment. The Canadian robotic manipulator has been eliminated. A big problem is clearance between solar arrays when an orbiter docks. Option B is similar to the baseline, i.e., it is based on Freedom components. Section P2 has been deleted from the baseline truss as well as alpha joints and resource nodes. The Option B team based at LaRC saved billions of dollars by reducing the amount of hardware attached outside the pressured modules and simplifying the data management system while sticking essentially with the basic Freedom design. I feel that no matter which design is selected for Freedom, ASCD has played and will play an important role in its final development (including configuration evolution and subsystem growth requirements).

In order to better understand the space-based Earth observing systems, I studied NASA Reference Publication 1009, "An Introduction to Orbit Dynamics and the application to Satellite-Based Earth Monitoring Missions," by David Brooks of LaRC and research the following satellite programs for appropriate information such as purpose, launch vehicle, payload instrumentations, costs, etc.:

1. U.S. Global Change Research Program (USGCRP)
2. Earth Observing System (EOS)
3. Solid Earth Science Missions (SESM)
  - a. Magnetic Satellite (MAGSAT)
  - b. Laser Geodynamics Satellite (LAGEOS I and II)
  - c. Magnetic Field Experiment (MFE/Magnolia)
  - d. Application and Research Involving Technologies Observing the Earth's Field from Low Earth Orbiting Satellite (ARISTOTELES)
  - e. Gravity and Magnetic Earthprobe Studies (GAMES)
  - f. Geomagnetic Observing System (GOS)

Of the missions listed under 3 above, I studied GAMES in the most detail. GAMES is a viable geopotential fields mission to replace ARISTOTELES. It is a high-value, low-cost mission that will have a pegasus launch. It will be equipped with magnetometers like the ones used on the MFE/magnolia mission. Accelerometers will be on the spacecraft to measure drag. It will measure gravity via long wavelength with a GPS receiver and short wavelength with a subsatellite tracker (0.01E gradiometer). Subsatellite performance analysis via the modeling approach has been done at LaRC to define the flight characteristics of the passive aerodynamically stabilized subsatellite and to evaluate its compliance with mission requirements. The analysis conducted to date show that for Mission 1 ("Primary Mission") a passive aerodynamically stabilized, magnetically damped subsatellite meets the feasibility requirement of steady state performance, deployment damping, and orbit lifetime. For Mission 2 ("Extended Mission") deployment damping and orbit lifetime requirements are met; however, the steady state attitude oscillations at 450 km far exceed the +/- 9 degrees requirement.

Two ongoing operational missions I examined were the Upper Atmosphere Research Satellite (UARS) and the Ocean Topography Experiments (TOPEX/Poseidon).

Finally, I investigated the proposed Advanced Research and Development/Small, Expendable Launch Vehicles (AR&D/SELV) Initiative.

## FIBER OPTIC SENSORS FOR CORROSION DETECTION

By

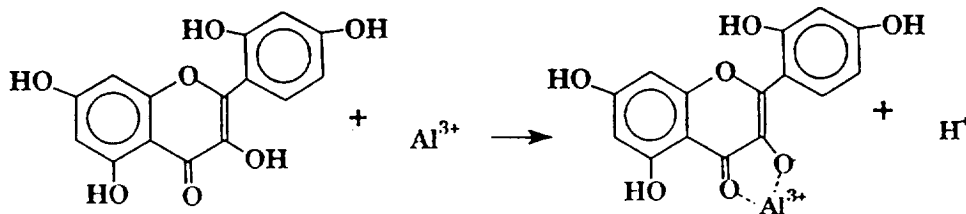
Professor Alphonso C. Smith  
 Department of Engineering  
 Hampton University  
 Hampton, VA 23668

## ABSTRACT

The development of fiber optic sensors<sup>[1-8]</sup> for the detection of a variety of material parameters has grown tremendously over the past several years. Additionally, the potential for analytical applications of fiber optic sensors have become more and more widely used. pH sensors have also been developed using fiber optic techniques to detect fluorescence characteristics from immobilized fluorogenic reagent chemicals.

The primary purpose of this research was to investigate the feasibility of using fiber optic sensors to detect the presence of  $Al^{3+}$  ions made in the process of environmental corrosion of aluminum materials. The  $Al^{3+}$  ions plus a variety of other type of metal ions can be detected using analytical techniques along with fiber optic sensors

In order to acquire some background data on the use of fiber optic sensors that could be used for corrosion detection, experiments were conducted in the laboratory using morin as a fluorogenic reagent. Morin is a chemical that is widely used for fluorimetric analysis of aluminum and other metals. It is only weakly fluorimetric by itself but forms highly fluorimetric complexes in the presence of  $Al^{3+}$  ions. The morin molecule has been extensively studied<sup>[8-10]</sup> and is used for analytical work, involving fluorimetric analysis of aluminum and other metals. It is also used for the spectrometric analysis of metals that do not form fluorescent complexes. This molecule comes under the flavonoids family. Hydroxyflavones belong to a vast class of flavonoid compounds - aromatic phenols of the general structure  $C_6 - C_3 - C_6$ . The flavonoids themselves can be identified through the characteristic color or fluorescence reaction with metals under suitable conditions. The fluorescence and color of the metal complexes formed depend on the number and position of the hydroxyl groups in the flavone molecule. The hydroxyl groups at the 3, 5, 2' - positions show the greatest effect on the fluorescence. Thus, morin (3, 5, 7, 2', 4'-pentahydroxyflavone) and datiscetin (3, 5, 7, 2'- tetrahydroxyflavone) have been used the most and these compounds have been found to be the most reactive and sensitive reagents among the flavones. These molecules contain a highly conjugated aromatic system, and consequently exhibit intense and characteristic absorption spectra. Flavones and flavonols generally exhibit two regions of intense absorption which fall in the ranges of 320-380 nm (Band I) and (240-270 nm (Band II). The addition of certain reagents to solutions of the flavones shifts the position of the absorption band maximum. Complex-formation by flavonoids with aluminum has long been used for the detection of certain hydroxy groups in these compounds. The flavonols form complexes with aluminum which are stable even in dilute hydrochloric acid. The complexation of the 3-hydroxyl group with metal ions, results in a structure as shown below which produces fluorescence that is detectable using fiber optic sensing techniques.



For this experiment morin was used in solution with aluminum nitrate to form a complexation process with  $Al^{3+}$  ions. A sample solution of morin and aluminum nitrate as shown in Figure 1 was excited with a UV light source, using separate monochromators for the excitation and emission radiation. For a selected excitation wave length of 416 nm a 12 inch length of sodium lime glass was used as a sensor. The sensor was immersed in a glass container enclosing the solution of morin and aluminum nitrate. The solution was excited with the UV source in a direction perpendicular to the axis of the glass sensor. Figure 2 shows the emission spectra centered at approximately 520 nm The emission spectra data was obtained for the detected fluorescence light focused through the monochromator used for emission detection and into the photomultiplier tube(PMT). The multimeter as shown in Figure 1 was used to measure the relative intensity of the light output from the photomultiplier tube as a function of wave length.

In this experiment it was determined that fiber optic sensing of fluorescence is rather easy to detect in a laboratory environment, using a solution of fluorescein reagent with a chemical to produce an abundance of  $Al^{3+}$  ions to complex with the reagent. Further studies will have to be conducted to determine the detectability limits, and the practicality of this application to structures where corrosion is activated in an environmental condition where the chemistry of active surfaces could change with time. Furthermore, several metal ions forms luminescent metals - chelate complexes. However, the relative non-specificity of many chelates and the similarity of fluorescence spectra of metal chelates of a given chelating agent, could hamper the selectivity of some experimental methods. This would be especially true in an uncontrolled environment that would exist in most practical applications of fiber optic sensing. As an example some chelating molecules forms fluorescent chelates with different metal ions. Therefore one would have to be sure that a separation procedure could be performed in order to determine the presence of one metal ion in the presence of another. Because of the rather large differences between the fluorescence lifetimes (several nanoseconds) any interference in signal detection could be resolved by using phase-resolved fluorescence spectroscopy (PRFS). This technique would help to enhance the signal to noise ratio due to background interferences and thus collectively help improve the measurement techniques.

#### REFERENCES

1. Brown, Stuart A.: "Optrodes" Anal. Chem. 53, 1616A-1618A (1981).
2. Saari, Linda A. and Seitz, W. Rudolf: "pH Sensor Based on Immobilized Fluoresceinamine" Anal. Chem. 54, 821-823(1982).
3. Saari, Linda, A. and Seitz, W. Rudolf: "Immobilized Morin as Fluorescence Sensor for Determination of Aluminum(III)", Anal. Chem. 55, 667-670 (1983).
4. Verorken, A. J. M.; Goos, C. M. A. A. and Hukkelhoven, M. W. A. C.: "Aluminum-Coated Cell for Fluorescence Signal Enhancement", Anal. Chem. 55, 2464-2466(1983).
5. Seitz, W. Rudolf: "Chemical Sensors Based on Fiber Optics", Anal. Chem. 56, 16A-34A(1984).
6. Saari, Linda A. and Seitz, W. Rudolf: "Optical Sensors for Beryllium Based on Immobilized Morin Fluorescence", Analyst 109, 655-657(1984).
7. Weaver, M. R. and Harris, J. M.: "In Situ Fluorescence Studies of Aluminum In complexation by 8 - Hydroxyquinoline Covalently Bound to Silica" Anal. Chem. 61, 1001-1010(1989).
8. Baldwin, Francesco: "Recent Progress in Fiber Optic pH Sensing" SPIE 1368, 184-190(1990).
9. Katyal, Mohan and Prakash, Shri: "Analytical Reactions of Hydroxyflavones", Talanta 24, 367-375(1977).
10. Katyal, Mohan: "Flavones as Analytical Reagents - A Review", Talanta 15, 95-106(1968).



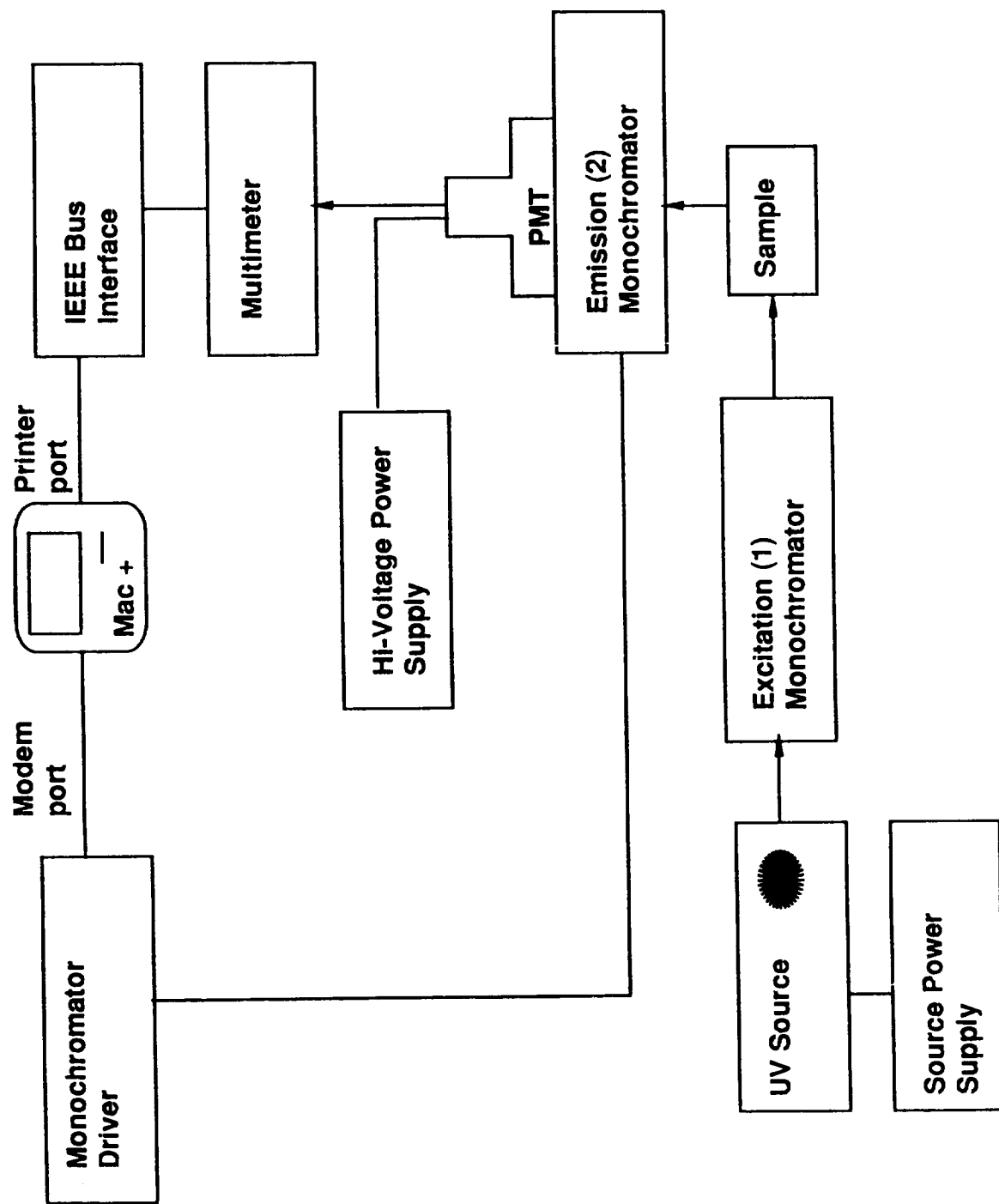
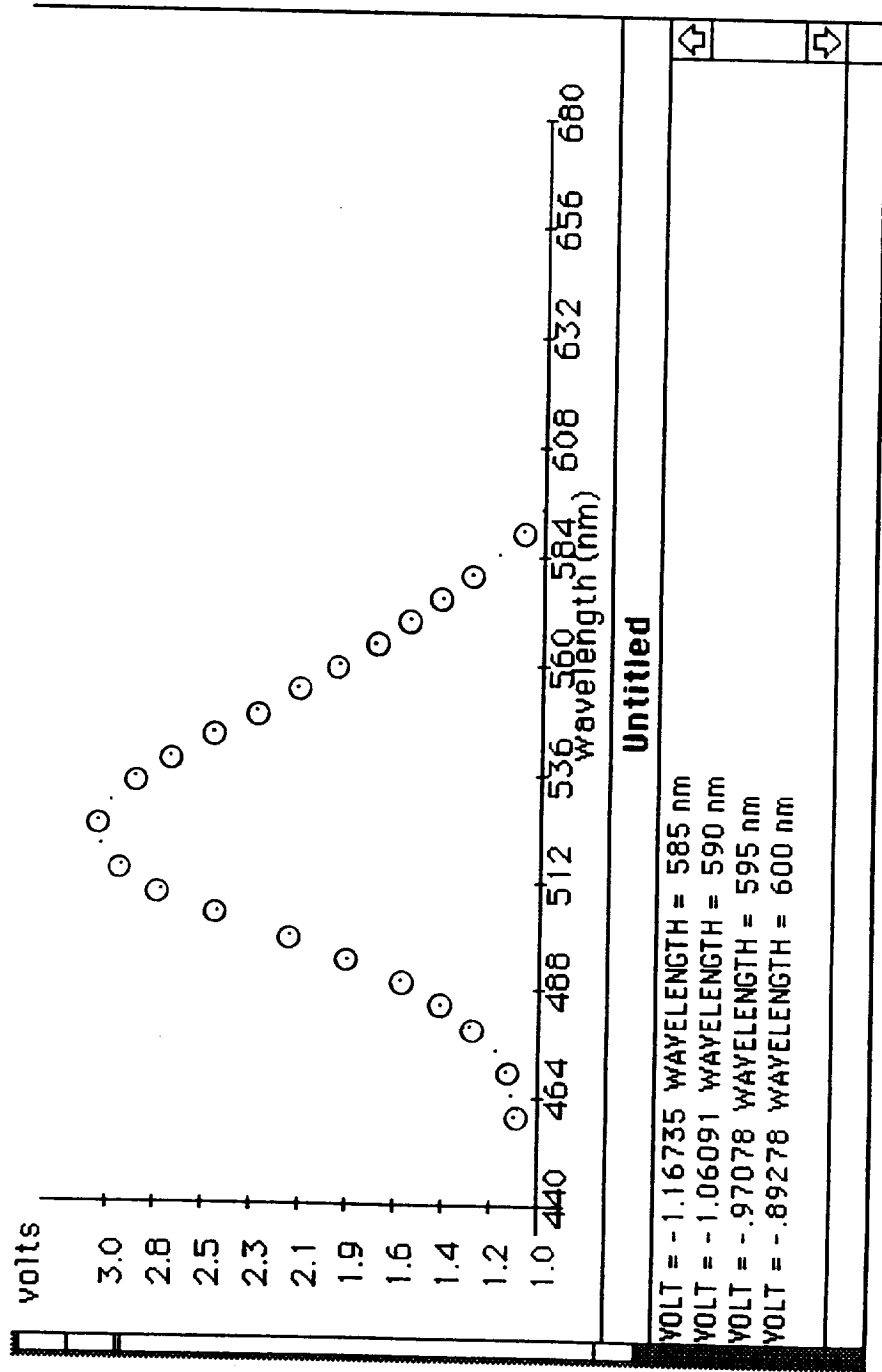


Fig. 1 Schematic Diagram of Automated Fluoremeter Experimental Setup



**Fig. 2 Experimental Data**

INVESTIGATION OF SPECTRAL ANALYSIS TECHNIQUES  
FOR RANDOMLY SAMPLED VELOCIMETRY DATA

by

Dave Sree  
Department of Aerospace & Mechanical Engineering  
Tuskegee University, Tuskegee, AL 36088

## ABSTRACT

It is well known that velocimetry (LV) generates individual realization velocity data that are randomly or unevenly sampled in time. Spectral analysis of such data to obtain the turbulence spectra, and hence turbulence scales information, requires special techniques. The "slotting" technique of Mayo et al [1], also described by Roberts and Ajmani [2], and the "Direct Transform" method of Gaster and Roberts [3] are well known in the LV community. The slotting technique is faster than the direct transform method in computation. There are practical limitations, however, as to how a high frequency an accurate estimate can be made for a given mean sampling rate. These high frequency estimates are important in obtaining the microscale information of turbulence structure. It has been found from previous studies [1-4] that reliable spectral estimates can be made up to about the mean sampling frequency (mean data rate) or less. If the data were evenly sampled, the frequency range would be half the sampling frequency (i.e. up to Nyquist frequency); otherwise, aliasing problem would occur. The mean data rate and the sample size (total number of points) basically limit the frequency range. Also, there are large variabilities or errors associated with the high frequency estimates from randomly sampled signals. Roberts and Ajmani [5] have proposed certain pre-filtering techniques to reduce these variabilities, but at the cost of low frequency estimates. The prefiltering acts as a high-pass filter. Further, Shapiro and Silverman [6] showed theoretically that, for Poisson sampled signals, it is possible to obtain alias-free spectral estimates far beyond the mean sampling frequency. But the question is, how far? During his tenure under 1993 NASA-ASEE Summer Faculty Fellowship Program, the author has investigated from his studies on the spectral analysis techniques for randomly sampled signals that the spectral estimates can be enhanced or improved up to about 4-5 times the mean sampling frequency by using a suitable prefiltering technique. But, this increased bandwidth comes at the cost of the lower frequency estimates. The studies further showed that large data sets of the order of 100,000 points, or more, high data rates, and Poisson sampling are very crucial for obtaining reliable spectral estimates from randomly sampled data, such as LV data. Some of the results of the current study are presented here.

Figures 1-2 show examples of the sine wave investigation. In Fig. 1, a 5000 Hz sine signal was sampled randomly (Poisson) at a mean frequency of only 100 Hz. The results show that the signal is easily detected even though the sampling frequency is 50 times less than the signal frequency. In Fig. 2, the case has been extended to a 10,000 Hz sine wave sampled at only 100 Hz (100 times less). Again, the signal is detected, though with some increased side noise.

Figure 3 shows the normalized spectral (power spectral density, PSD) estimates obtained for a simulated first-order spectrum (FOS) example. The FOS is considered here because it simulates closely a typical one-dimensional turbulence spectrum. PSD estimates were obtained for both unfiltered (circles) and prefiltered (squares) data. It can be seen from the results that, with prefiltering, the spectral estimates have been improved up to about 4-5 times the mean sampling frequency. The original unfiltered data provides reasonable estimates only up to about the mean sampling frequency or less. The high-pass filtering effect on the prefiltered data can be clearly seen from the results.

Figure 4 shows the normalized PSD estimates from Poisson and non-Poisson samples of a simulated FOS. It can be seen from the results that the estimates from non-Poisson samples deviate considerably from the true values, but do give useful information below about half the mean sampling frequency. The study further showed that the data from non-Poisson sampling were not amenable to spectral improvements by prefiltering techniques.

Further research is required to determine the effects of particle dynamics, nonhomogeneous seeding, velocity bias, etc. on the spectral estimates and to establish the accuracies and the confidence limits of these techniques. Research is also needed to extend the spectral analysis techniques to obtain cross-correlation and cross-power spectral estimates from randomly sampled 2-D/3-D LV experimental data.

#### REFERENCES

1. Mayo, Jr. W. T.; Shay, M. T.; and Riter, S.: "The Development of New Digital Data Processing Techniques for Turbulence Measurements with a Laser Velocimeter." Report No. AD-784-891, AEDC-TR-53, Texas A&M University, 1974.
2. Roberts, J. B.; and Ajmani, D. B. S.: "Spectral Analysis of Randomly Sampled Signals Using a Correlation-Based Slotting Technique." IEE Proc., 133, Pt. F, No. 2, pp. 153, 1986.
3. Gaster, M.; and Roberts, J. B.: "Spectral Analysis of Randomly Sampled Records by a Direct Transform Method." Proc. R. Soc. Lond. A., 354, pp. 27, 1977.
4. Srikantaiah, D. V.; and Coleman, H. W.: "Turbulence Spectra from Individual Realization Laser Velocimetry Data." Expts. in Fluids, 3, pp. 35, 1985.
5. Roberts, J. B.; and Ajmani, D. B. S.: "Variance Reducing Techniques for the Spectral Analysis of Randomly Sampled Signals." Proc. Intl. Specialists Meeting on the Use of Computers in Laser velocimetry, ISL, St. Louis, France, 1987.
6. Shapiro, H. S.; and Silverman, S. A.: "Alias-free Sampling of Random Noise." J. Soc. Ind. App. Math., 8, pp. 225, 1960.

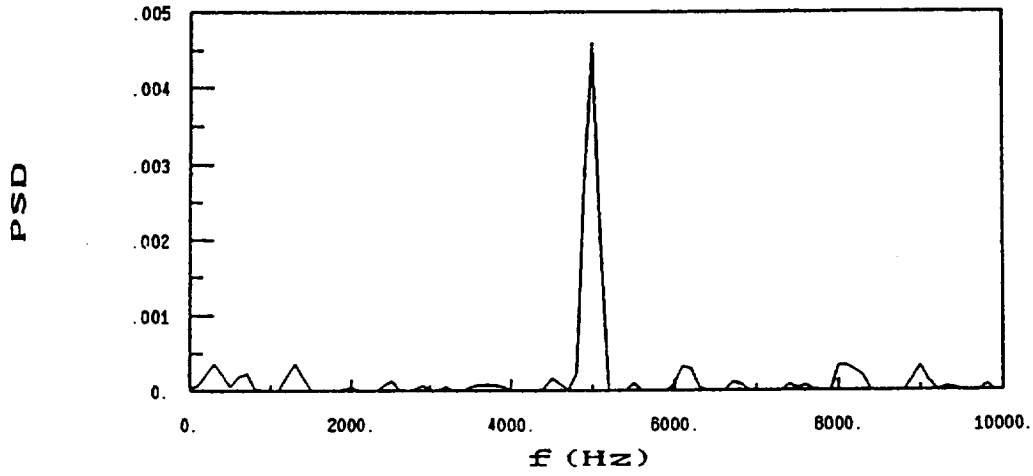


Fig. 1 Example of a 5000 Hz sine wave sampled (Poisson) at a mean sampling rate of 100 Hz. The signal is detected by the slotting technique of spectral analysis even though the sampling rate is 50 times less than the signal frequency. (PSD = Power Spectral Density)

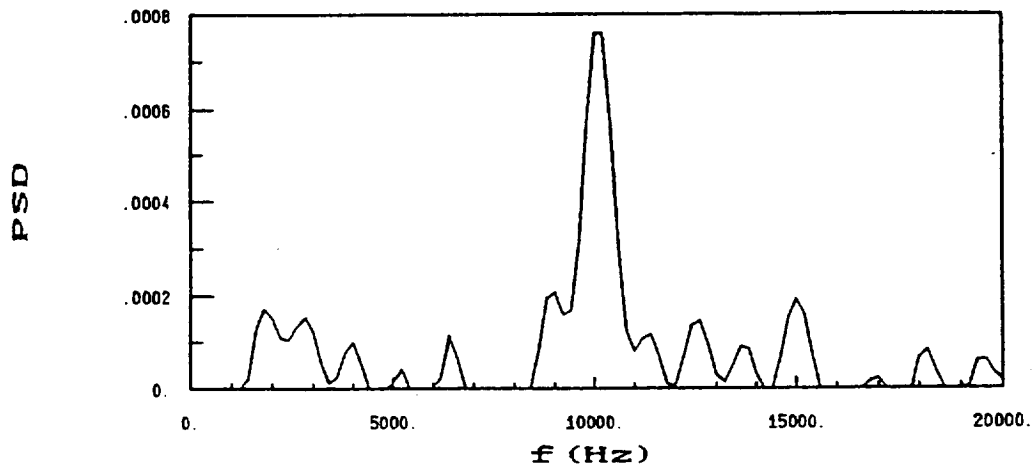


Fig. 2 Example of a 10,000 Hz sine wave sampled (Poisson) at a mean sampling rate of only 100 Hz (100 times less). The signal is still detected fairly by the slotting technique.

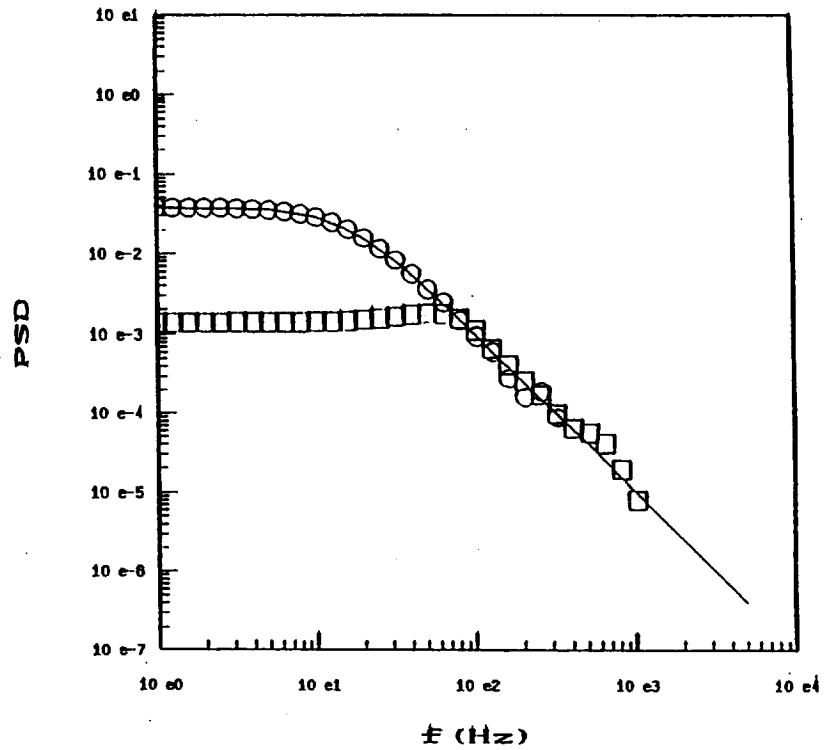


Fig. 3 Example of a simulated first-order spectrum (FOS) sampled at a mean sampling rate of 200 Hz. Solid line represents the theoretical spectrum. Circles denote the spectral estimates of the original unfiltered data and squares that of the prefiltered data. Note the high-pass filtering effect and the improvement of the spectral estimates up to about 4-5 times the sampling frequency.

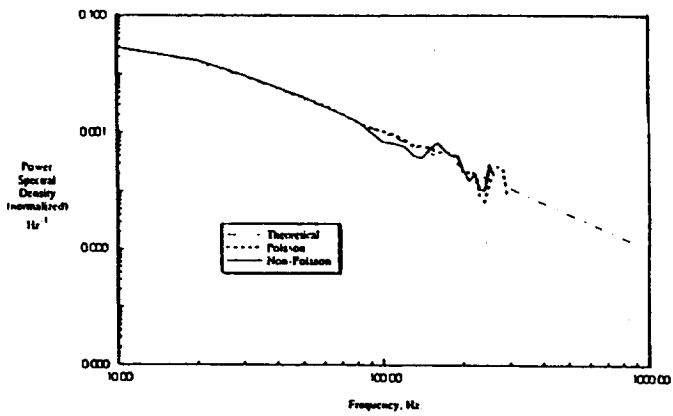


Figure 4. Power Spectra of Poisson and Non-Poisson Data of a Simulated First-Order Spectrum. Data Rate = 200/s.

**COMPARATIVE ANALYSIS OF DIFFERENT CONFIGURATIONS OF  
PLC-BASED SAFETY SYSTEMS FROM RELIABILITY  
POINT OF VIEW**

Moiez A. Tapia, Ph.D.

Professor of Electrical and Computer Engineering  
University of Miami  
P. O. Box 248294  
Coral Gables, Florida 33124-8294

Supervised by

V. William Wessel, Head  
Risk Management Branch  
Systems Safety, Quality and Reliability Division

**Abstract**

The report presents the study of a comparative analysis of distinct multiplex and fault-tolerant configurations for a PLC-based safety system from a reliability point of view. It considers simplex, duplex and fault-tolerant triple redundancy configurations. The standby unit in case of a duplex configuration has a failure rate which is  $k$  times the failure rate of the standby unit, the value of  $k$  varying from 0 to 1. For distinct values of MTTR and MTTF of the main unit, MTBF and availability for these configurations are calculated. The effect of duplexing only the PLC module or only the sensors and the actuators module, on the MTBF of the configuration, is also presented. The results are summarized and merits and demerits of various configurations under distinct environments are discussed.

**Summary of Results**

The MTBF of the wind tunnel safety was estimated to be about 100 hours, those for the PLC module and sensors/actuators module were estimated to be 250 and 168 hours, respectively. The factor by which the simplex system MTBF increases by using redundancy is dependent on the value of the MTTR. It is given in the table below. (All the tables in this section assume 100% use factor.)

**Table 1**

MTTR (HOURS):	4	24	168	720
Duplex (Cold, $k = 0.1$ ):	24.6	5.7	2.5	2.0
Duplex (Hot, $k = 1$ )	14	3.6	1.8	1.6
3MR	5	1.5	.93	.86

Duplexing only the PLC module leads to an increase in the system MTBF by a factor given in the table below:

(Recall estimated MTTF values. For PLC module: 250 hours; for sensors/actuators module: 168 hours; for the whole simplex system: 100 hours).

**Table 2**

MTTR (HOURS):	4	24	168	720
Duplex (Cold, $k = 0.1$ ):	1.66	1.60	1.47	1.41
Duplex (Hot, $k = 1$ )	1.65	1.54	1.37	1.31

Duplexing only the sensors/actuators module leads to an increase in the system MTBF by a factor given in the table below.

(Recall estimated MTTF values. For PLC module: 250 hours; for sensors/actuators module: 168 hours; for the whole simplex system: 100 hours).

**Table 3**

MTTR (HOURS):	4	24	168	720
Duplex (Cold, $k = 0.1$ ):	2.41	2.14	1.74	1.62
Duplex (Hot, $k = 1$ )	2.35	1.95	1.53	1.42

Observe that partial duplexing leads to a modest increase in the system MTBF. Duplexing only the PLC module leads to a smaller increase than what we would get if we duplex only the sensors/actuators module.

**Duplexing only the processor, memory, and interface modules and leaving the input/output and sensors/actuators modules simplex leads to virtually no increase in the system MTBF.**



## Property Enhancement of Polyimide Films Via the Incorporation of Lanthanide Metal Ions

by

Professor David W. Thompson  
Department of Chemistry  
College of William and Mary  
Williamsburg, Virginia 23185

### ABSTRACT

Lanthanide metal ions have been incorporated into the polyimide derived from 2,2-bis(3,4-dicarboxyphenyl)hexafluoropropane dianhydride (6FDA) and 1,3-bis(aminophenoxy)benzene (APB) in an attempt to produce molecular level metal-polymer composites. The lanthanide series of metal ions (including aluminum, scandium, and yttrium) provide discrete and stable metal ions in the 3+ oxidation state. Throughout the series there is a uniform variation in ionic size ranging from 50 pm for aluminum to a maximum of 103.4 pm for cerium and gradually decreasing again to 84.8 pm for lutetium. The high charge-to-size ratio for these ions as well as the ability to obtain large coordination numbers makes them excellent candidates for interacting with the polymer substructure.

The distinct lack of solubility of simple lanthanide salts such as the acetates and halides has made it difficult to obtain metal ions distributed in the polymer framework as discrete ions or metal complexes rather than microcomposites of metal clusters. (Lanthanum nitrates are quite soluble, but the presence of the strongly oxidizing nitrate ion leads to serious degradation of the polymer upon thermal curing. This work has been successful at extending the range of soluble metals salts by using chelating agents derived from the  $\beta$ -diketones dipivaloylmethane, dibenzoylmethane, trifluoroacetylacetone, and hexafluoroacetylacetone. Metal acetates which are insoluble in dimethylacetamide dissolve readily in the presence of the diketones. Addition of the polyimide yields a homogeneous resin which is then cast into a clear film. Upon curing clear films have been obtained with the dibenzoylmethane and trifluoroacetylacetone ligands. The dipivaloylmethane precipitates the metal during the film casting process, and hexafluoroacetylacetone gives cured films which are deformed and brittle. These clear films are being evaluated for the effect of the metal ions on the coefficient of thermal expansion, resistance to atomic oxygen, and on selective gas permeability.

Much more commonly than above, polyimide films are prepared by casting the film as the poly(amic acid) precursor which is then converted to the imidized form during the thermal cure cycle. Very limited success has been achieved in the past in adding lanthanide metal ions to the amide precursors because of gellation and lack of solubility. With the use of the diketone ligands cited above, the solubility and gellation problems were overcome. However, the films after curing were clear but unacceptably brittle. Attempts to overcome this cure embrittlement problem are in progress.

**ADP Analysis Project  
for the  
Human Resources Management Division**

**by**

**Professor Robert L. Tureman, Jr.  
Computer Information Systems Department  
Paul D. Camp Community College  
Suffolk, VA 23434**

**ABSTRACT** - The ADP (Automated Data Processing) Analysis Project was conducted for the Human Resources Management Division (HRMD) of NASA's Langley Research Center. The three major areas of work in the project were computer support, automated inventory analysis, and an ADP study for the Division. The goal of the computer support work was to determine automation needs of Division personnel and help them solve computing problems. The goal of automated inventory analysis was to find a way to analyze installed software and usage on a Macintosh. Finally, the ADP functional systems study for the Division was designed to assess future HRMD needs concerning ADP organization and activities.

**INTRODUCTION** - The Human Resource Management Division of NASA's Langley Research Center has seen rapid growth in the use of automation in the past few years. This has been escalated by the growing use and interest in desktop computing. Division computing resources are already used at near capacity. The ADP Analysis Project provided immediate short term help with computing work and started a longer range examination of the ADP process. The overall objective of the project was to help the Division expand its computing capabilities and understanding.

**PROJECT ACTIVITY** - There were three major areas of work in the project: computer support, automated inventory analysis, and an ADP study for the Division. This project used resources from the Evaluation and Information Center (EIC), special project documentation and software resources available in the Division and from the research Fellow's personal library. In addition, the work was dependent upon the insights and perceptions of Division personnel into their particular job functions and organizational needs.

The goal of the computer support work was to determine needs of Division personnel and help them solve computing problems. This included assisting specialists in analyzing computer work, analyzing software and hardware problems and offering solutions, assisting in small group training for a new online capability and performing research on computing topics of interest to specialists and staff members. The topics explored and documented included reviews of available

Macintosh software and information concerning the possibilities for cross-platform transfer of a Pascal program, namely from the DOS environment to the Macintosh.

Automated inventory analysis was the second major part of the project. The goal of this work was to find a way to analyze what software is installed on a Macintosh computer and determine software usage. Research showed that the Norton Utilities for the Macintosh produced a report with the content needed to perform the analysis. A procedure was developed to allow a cooperative education student to extract the inventory for each Macintosh and save it in a postscript file. After this, a program was developed to extract the currently installed software, including system startup programs. In addition, the program passively analyzed software usage by looking at creation date and file type, which is explicit in the Macintosh environment. Of course, this only logged hard disk activity and therefore does not create a definitive log as an active process would. However, it did offer some clues as to actual use of the system and will help HRMD formulate questions as they make decisions concerning limited computer and software resources. The programs were developed in Turbo Pascal and produced a report in an average of 29.3 seconds per user on a 386 in the final run for the machines studied in the Division. Future work will involve the transfer of these programs to the Macintosh.

The ADP (Automated Data Processing) functional systems study for the Division involved developing information gathering tools and collecting data to assess the future needs concerning ADP organization and activities. Sixteen key Division personnel were selected to be included in the work, covering the areas of management, specialists and support personnel. Information was collected using an objective tool and a personal interview. The interview lasted just over an hour on average per participant. A report detailing and analyzing the collected data was developed for the Division. The report details skills, characteristics and some job functions that the Division sees as important in the ADP organization. It also presents short term and longer range issues that need to be addressed. Finally, some recommendations are presented concerning alternative approaches to reach ADP objectives.

**APPLICATION TO HRMD** - The intent of the computer support work was to help HRMD personnel become more adept in analyzing and solving computer related problems. In all cases, an attempt was made to transfer the knowledge to HRMD personnel to have an effect on the organization's total computing skill. The inventory analysis programs, procedures and reports have been set up so they can be available for use by the Division. Finally, the ADP study will be used by the Associate Chief and other management staff to make plans for the future of ADP in the Division.

**CONCLUDING REMARKS** - The Division continues to place a priority on proper application of computing skill to job related tasks. This work has enhanced current Division skills and provided planning which can be used by management to direct future activities.

## SPACE TRANSPORTATION VEHICLE DESIGN EVALUATION USING SATURATED DESIGNS

Resit Unal  
Associate Professor  
Old Dominion University  
Norfolk, VA 23529

An important objective in the preliminary design and evaluation of space transportation vehicles is to find the best values of design variables that optimize the performance characteristic (e.g. dry weight). For a given configuration, the vehicle performance can be determined by the use of complex sizing and performance evaluation computer programs. These complex computer programs utilize iterative algorithms and they are generally too expensive and/or difficult to use directly in multidisciplinary design optimization. An alternative is to use response surface methodology (RSM) and obtain quadratic polynomial approximations to the functional relationships between performance characteristics and design variables [2]. In RSM, these approximation models are then used to determine optimum design parameter values and for rapid sensitivity studies.

Constructing a second-order model requires that "n" design parameters be studied at least at 3 levels (values) so that the coefficients in the model can be estimated.

Therefore,  $3^n$  factorial experiments (point designs or observations) may be necessary. For small values of "n" such as two or three, this design works well. However, when a large number of design parameters are under study, the number of design points required for a full-factorial design may become excessive.

Fortunately, these quadratic polynomial approximations can be obtained by selecting an efficient design matrix using central composite designs (CCD) from design of experiments theory [3,7]. Each unique point design from the CCD matrix is then conducted using computerized analysis tools (e.g. POST, CONSIZ, etc.). In the next step, least squares regression analysis is used to calculate the quadratic polynomial coefficients from the data.

However, in some multidisciplinary applications involving a large number of design variables and several disciplines, the computerized performance synthesis programs may get too time consuming and expensive to run even with the use of efficient central composite designs. In such cases, it may be preferable to keep the number of design points to an absolute minimum and trade some model accuracy with cost. For this purpose, another class of experimental designs, called saturated D-optimal designs may be utilized for generating a matrix of vehicle designs. A design is called saturated when the number of design points is exactly equal to the number of terms in the model to be fitted [4,5]. As a result, saturated designs require the absolute minimum number of design points  $((n+1)(n+2)/2)$  to estimate the quadratic polynomial model coefficients.

Saturated designs can be generated using the D-optimality criterion. A good saturated design should give rise to least squares estimates with minimum generalized variance. To achieve this, the determinant  $|X'X|$ , which is a measure of variance, should be as large as possible [1,6]. Designs that maximize  $|X'X|$  are referred to as D-optimal designs.

D-optimal designs are constructed by selecting an optimal set of points from a candidate set that one wish to consider. The D-optimal design is made up of points from the candidate set using an exchange algorithm to maximize the determinant of  $X'X$ . However,

this is a very difficult problem due to the large number of variables which must be handled ( $np$ ) and due to the complicated nature of the objective function  $X'X$ , especially the existence of several local maxima [1,4].

A number of authors developed algorithms and obtained D-optimal designs for specific models using mathematical programming methods to optimize the determinant  $|X'X|$  [1,3,6,9]. Box and Draper list several saturated quadratic designs for "n" variables and suggest optimal settings of the design points by using the D-optimality criterion of maximizing the determinant  $|X'X|$  for the cases of  $n=2$  and 3 variables [1,3]. Box and Draper generalized these designs for  $n \geq 4$  [1]. There is some argument in the literature about the D-optimality of these generalized designs when  $n \geq 4$ , in the sense of maximizing  $|X'X|$  [3,4,5]. Box and Draper pointed out that Dubova and Federov had found a better design for  $n=4$  [1,3]. However, Box and Draper argue that their generalized designs provide saturated designs with reasonably high D-efficiency when the number of variables exceeds four [1,3] and these designs should work well.

On the limiting side, D-optimal designs do not contain an equal number of high-level, medium-level and low-level values. Classical designs like, orthogonal arrays and central composite designs are based on balanced and orthogonal mathematical patterns, while D-optimal designs are straight optimizations of a criterion based on the model to be fit [10]. There appears to be no guarantee that the result is actually optimal since the search for D-optimal designs is fraught with local and multiple optima problems [4]. However, these designs appear to work reasonably well in initial screening situations in which it is expected that there will only be a few important parameters [10]. As a result, saturated D-optimal designs may be used in lieu of central composite designs when there are large number of variables under study and experimental point design effort is very expensive.

#### References:

1. Box, M.J. and Draper, R.D., 1974, "On-Minimum Point Second-Order Designs," Technometrics, Vol. 16, No. 4, November.
2. Craig, J.A., 1978, "D-Optimal Design Method: Final Report and User's Manual," USAF Contract F33615-78-C-3011, FZM-6777, General Dynamics, Fort Worth Division.
3. Khuri, A.I., and Cornell, J.A., 1987, Response Surfaces: Designs and Analyses, Marcel Dekker Inc., New York.
4. Lucas, J.M., 1974, "Optimum Composite Designs," Technometrics, Vol. 16, No. 4, November.
5. Mitchell, T.J., 1974, "Computer Construction of 'D-Optimal' First Order Designs," Technometrics, Vol. 16, No. 2, May.
6. Mitchell, T.J., 1974, "An Algorithm for the Construction of 'D-Optimal' Experimental Designs," Technometrics, Vol. 16, No. 2, May.
7. Myers, R.H., 1971, Response Surface Methodology, Virginia Commonwealth University, Allyn and Bacon Inc., Boston Mass.
8. Schnackel, J. and Dovenmuehle, R., 1990, "Statistical Experimental Design and its Role in Aerospace Vehicle Design Efforts," AIAA-90-1809, February.
9. St. John, R.C., 1975, "D-Optimality for Regression Designs: A Review," Technometrics, Vol. 17, No. 1, February.
10. D.K. Lin, 1993, "Another Look at First-Order Saturated Designs: The p-efficient Designs," Technometrics, Vol. 35, No. 3, August .

# PREDICTION OF LEADING-EDGE TRANSITION AND RELAMINARIZATION PHENOMENA ON A SUBSONIC MULTI-ELEMENT HIGH-LIFT SYSTEM

by

Professor C. P. van Dam  
Department of Mechanical and Aeronautical Engineering  
University of California  
Davis, CA 95616

## Abstract

Boundary-layer transition and relaminarization may have a critical effect on the flow development about multi-element high-lift systems of subsonic transport jets with swept wings. The purpose of my research this summer is to study these transition phenomena in the leading-edge region of the various elements of a high-lift system. The flow phenomena studied include transition of the attachment-line flow, relaminarization, and crossflow instability and transition. The calculations are based on pressure distributions measured in flight on the NASA Transport Systems Research Vehicle (Boeing 737-100) at a wing station where the flow approximated infinite swept wing conditions. The results indicate that significant regions of laminar flow can exist on all flap elements in flight. In future flight experiments (planned for January-February, 1994) the extent of these regions, the transition mechanisms and the effect of laminar flow on the high-lift characteristics of the multi-element system will be further explored.

## Project Background and Results

The aerodynamic design of an effective high-lift system remains as challenging today as it was twenty years ago when A.M.O. Smith wrote his enlightening papers on high-lift aerodynamics.<sup>1,2</sup> Modern jet transports require complex multi-element high-lift systems to meet stringent performance criteria during takeoff and landing. In the current competitive market place, new transport-jet designs are driven to simpler, more efficient high-lift systems that provide improved aerodynamic performance in terms of increased maximum lift coefficient,  $C_{L_{max}}$ , increased  $L/D$ , or increased lift coefficient,  $C_L$ , for a given angle of attack and flap setting.<sup>3</sup> Solving the aerodynamic design problem of high-lift systems has been a difficult task primarily because of the limited understanding of the flow physics associated with such systems.

The flow field around a high-aspect-ratio swept wing with its multi-element high-lift system deployed is characterized by a number of aerodynamic phenomena which are highly interrelated and complex in nature. Smith<sup>1,2</sup> concentrated in his papers on the aerodynamic processes that occur in flows past two-dimensional multi-element airfoils at high-lift conditions. These phenomena include inviscid- and viscous-flow interactions between the various elements, boundary-layer transition, and flow separation. Currently many of these flow phenomena can be analyzed fairly accurately with two-dimensional computational methods based on the full Navier-Stokes equations<sup>4,5,6</sup> or a reduced set of these equations (e.g., Euler equations coupled with boundary-layer equations<sup>7</sup>). Unfortunately our understanding of these phenomena in three dimensions is less extensive than of the two-dimensional phenomena; the main reasons being a lack of detailed flow measurements for three-dimensional high-lift flows and a lack of computational methods that can adequately compute (separated) viscous flows past wings with deployed multi-element high-lift systems. Three-dimensional flow phenomena such as (1) transition of the attachment-line boundary layers, (2) relaminarization of turbulent flow in the leading-edge regions of the elements and (3) crossflow instability and transition of the laminar flow downstream of the attachment lines, among others can be significant in the aerodynamic design and analysis of a high-lift system.<sup>8</sup>

The influence of the boundary-layer state in the leading-edge region on high-lift

performance is illustrated for a single-element swept lifting surface in Fig.1. Loss of laminar flow due to attachment-line contamination at high Reynolds numbers can result in a noticeable drop in maximum lift as shown in Fig.1. This adverse scale effect on lift makes it difficult to extrapolate maximum-lift data from low (wind-tunnel) Reynolds-number to high (flight) Reynolds-number conditions. In addition, note that even at full-scale flight conditions the smaller elements of the high-lift system may be operating at low (chord) Reynolds numbers where their flows are dominated by laminar bubbles. Therefore, determining the transition location and understanding the mechanisms that govern transition are crucial to the accurate prediction of high-lift system performance.

As part of the subsonic transport high-lift research program, a flight experiment is being conducted using the NASA Langley Transport Systems Research Vehicle (TRSV) to obtain detailed high-lift flow measurements at full-scale high-Reynolds-number conditions. The purpose of my efforts this summer is to study leading-edge transition and relaminarization phenomena for this typical subsonic transport high-lift system using flight-measured pressure distributions. The results of this study are being used to define transition instrumentation on future flights planned for January-February 1994. The results indicate that significant regions of laminar flow can exist on all five elements of the high-lift system at full-scale flight conditions and indicate the importance of measuring the state of the boundary layer in the leading-edge region of the various elements because of its dominant role in determining the high-lift performance characteristics. Many of the results are reported in the paper that was presented at the AIAA Fluid Dynamics Conference.<sup>9</sup>

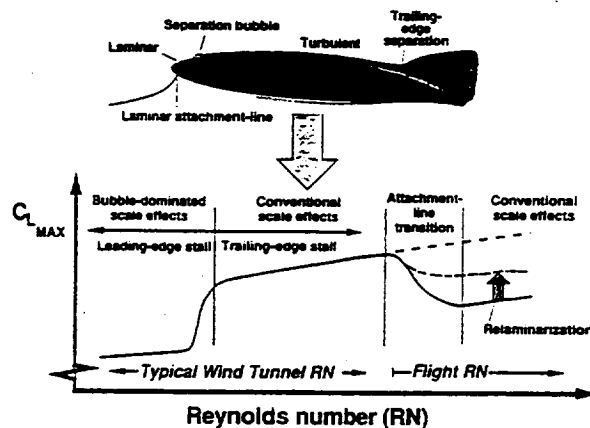


Fig.1 Effect of attachment-line transition and relaminarization on maximum lift coefficient for a single-element lifting surface.

<sup>1</sup>Smith, A. M. O., "Aerodynamics of High-Lift Airfoil Systems," in *Fluid Dynamics of Aircraft Stalling*, AGARD CP-102, Nov. 1972, pp. 10/1-27.

<sup>2</sup>Smith, A. M. O., "High-Lift Aerodynamics," *Journal of Aircraft*, Vol. 12, No. 6, June 1975, pp. 501-530.

<sup>3</sup>Garner, P. L., Meredith, P. T., and Stoner, R. C., "Areas for Future CFD Development as Illustrated by Transport Aircraft Applications," AIAA Paper 91-1527-CP, June 1991.

<sup>4</sup>Mavripilis, D., "Turbulent Flow Calculations using Unstructured and Adaptive Meshes," ICASE Report 90-61, NASA CR 182102, Sept. 1990.

<sup>5</sup>Rogers, S. E., "Progress in High-Lift Aerodynamic Calculations," AIAA Paper 93-0194, Jan. 1993.

<sup>6</sup>Anderson, W. K., and Bonhaus, D. L., "Navier-Stokes Computations and Experimental Comparisons for Multi-Element Airfoil Configurations," AIAA Paper 93-0645, Jan. 1993.

<sup>7</sup>Drela, M., "Newton Solution of Coupled Viscous/Inviscid Multi-Element Airfoil Flows," AIAA Paper 90-1470, June 1990.

<sup>8</sup>Hardy, B. C., "An Experimental Investigation of Attachment-Line Transition on the Slat of a Combat Aircraft Model," in *High-Lift Systems Aerodynamics*, AGARD CP-415, Oct. 1992, pp. 18/1-11.

<sup>9</sup>van Dam, C. P., Vijgen, P. M. H. W., Yip, L. P., Potter, R. C., "Leading-Edge Transition and Relaminarization Phenomena on a Subsonic High-lift System," AIAA Paper 93-3140, July 1993.

**COMPUTATION OF TRANSONIC VISCOUS FLOW  
PAST THE NTF 65-DEGREE DELTA WING**

by

Professor Chivey Wu  
Department of Mechanical Engineering  
California State University  
Los Angeles, CA90032

Abstract

This project is a continuation of the work performed in the summers of 1991 and 1992, during which a 9-block structured grid for the computational domain around each of the four NTF 65-degree Delta Wing models with the sting mount were created. The objective of the project is to validate and supplement the test data on the wing models by computing the viscous flow field about the models.

The CFL3D code, which solves the full Navier-Stokes equations with an implicit upwind finite-volume scheme, has been employed to perform the viscous flow simulation. Preliminary solution to the small radius-leading edge wing model has been obtained for the following transonic cases, all at a Reynold's number of  $9 \times 10^6$ :

<u>Mach</u>	<u>Angle of Attack</u>	<u>Turbulence Model</u>	<u>Lift Coeff</u>	<u>Drag Coeff</u>
0.85	12°	(Laminar)	0.530	0.109
0.8	6°	(Laminar)	0.257	0.026
0.8	6°	Baldwin-Lomax	0.242	0.022

Results of a typical case are presented in Figures 1 to 3. In this case, separation occurs along the leading edges and a pair of primary vortices are formed on the upper surface. Streamlines and pressure variation in the vortices are depicted in Figure 1. Formation of a secondary and a tertiary vortex beneath each primary vortex is also predicted. In Figure 2, the pressure contours on both the upper and lower surfaces of the wing model and the sting joint are traced. The low pressure region along the leading edge on the upper surface also indicates the formation of the vortices.

The wing models were tested in the NTF 8-foot Transonic Wind Tunnel in summer of 1991, and spanwise pressure distribution were obtained for numerous test cases. Figure 3 shows fairly good agreement between the computed result and the experimental data for the present case. The numerical simulation is able to predict the general location and strength of the primary vortex, but does not quite match the sharp pressure gradient in the vortex as indicated by the experimental data. This discrepancy is also observed in all other cases computed. It is believed that this discrepancy can be eliminated by adding or redistributing more grid points near the location where the vortex occurs. This is being attempted.



NTP 65-deg DELTA WING

Small Radius-L.E.

$M=0.85$ ,  $\text{Alpha}=12$  deg,  $\text{Re}=9m$

Laminar Solution

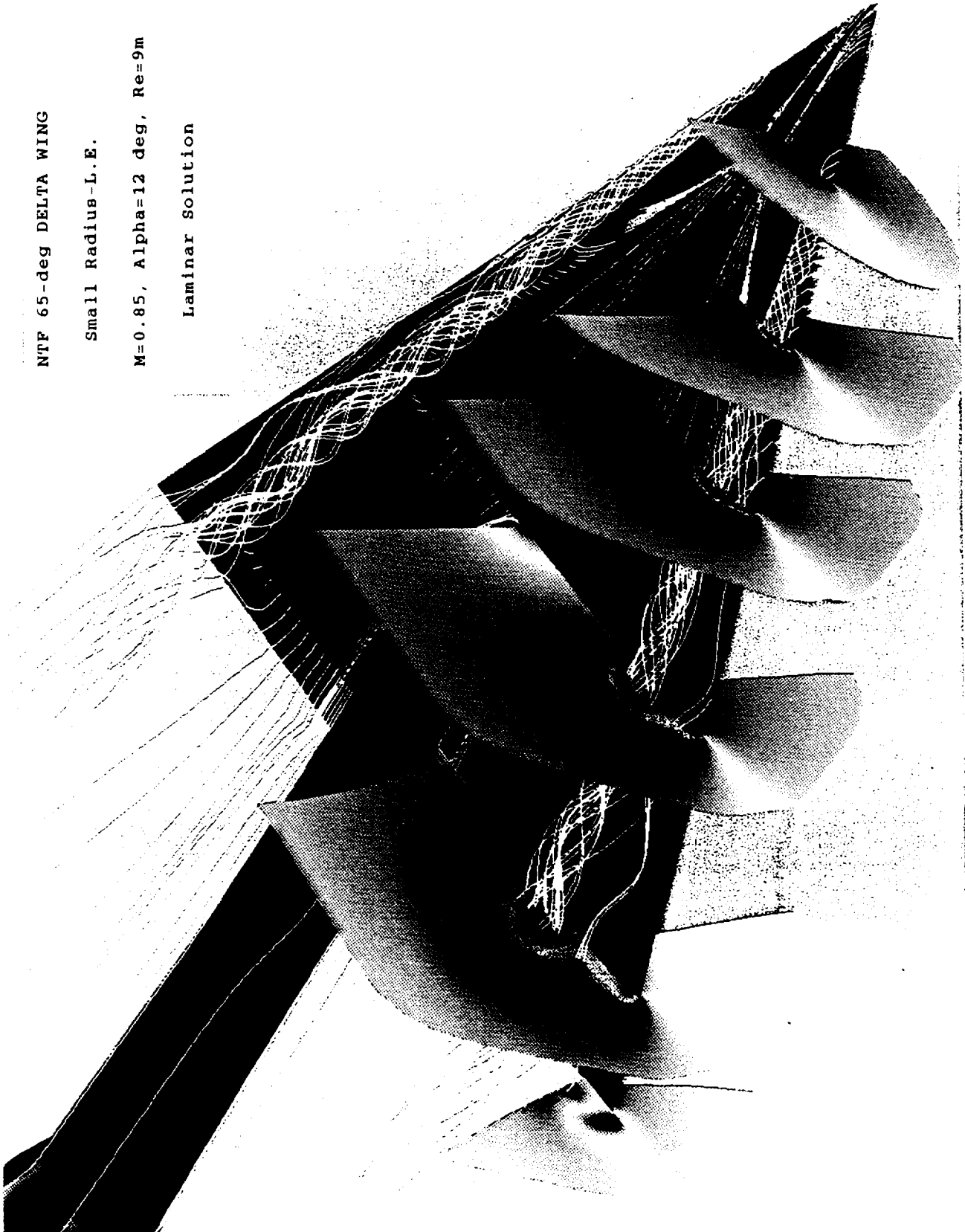


Fig. 1 Pressure Coefficient Contours and Line Trace in Vortex

NTF 65-deg DELTA WING

Small Radius - L.E.

$M=0.85$ ,  $\text{Alpha}=12$  deg,  $Re=9$  in

Laminar Solution:  $C_p$ -Dist.

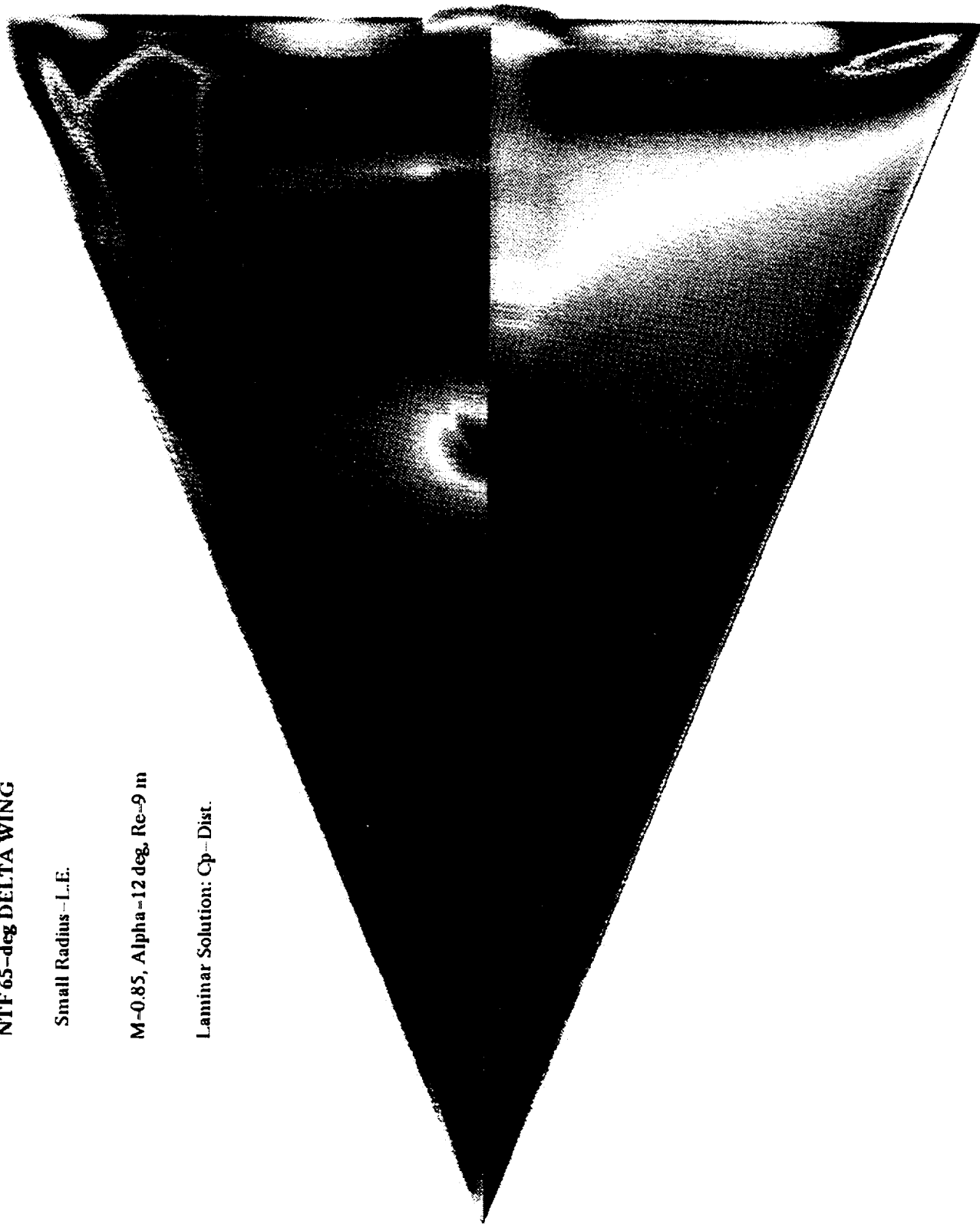


Fig 2. Pressure Coefficient Contours on Wing Surface

# 65° Delta Wing Spanwise Pressure Coefficients

Small Radius L.E.

— CFL3D - Laminar-Upper Surface  
 ..... CFL3D - Laminar-Lower Surface  
 ● Expt. Data-Upper Surface  
 ○ Expt. Data-Lower Surface  
 $M_\infty = 0.85$   
 $\Gamma_{critical} = 9 \times 10^6$   
 $\alpha = 12^\circ$

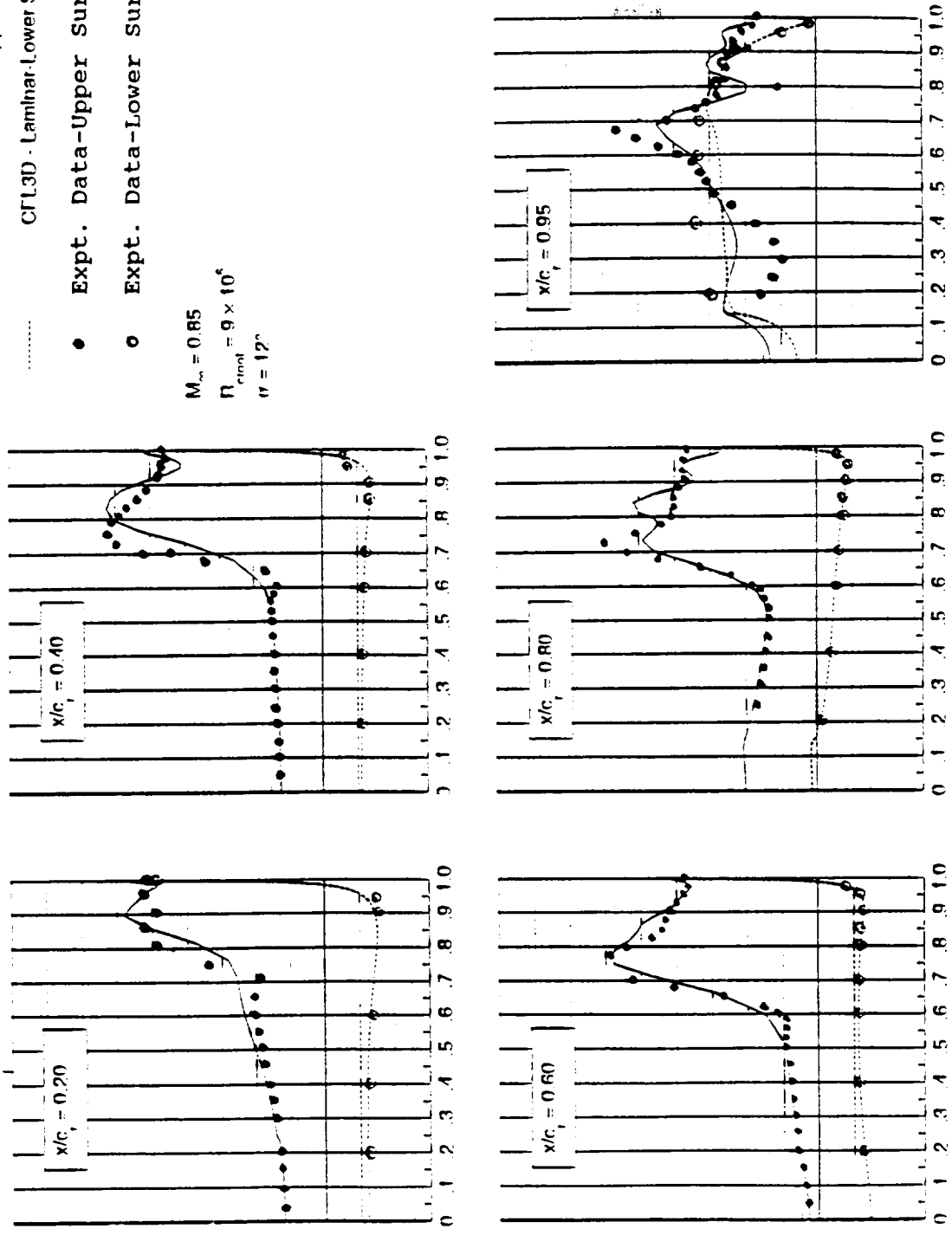


Fig 3. Comparison of Computed Cp-Distribution with NTF Data

**APPENDIX XI**  
**PROGRAM ORIENTATION EVALUATION REPORT**

**1993 American Society for Engineering Education (ASEE)  
Summer Faculty Fellowship Program**

**Orientation Evaluation Report**

**June 7, 1993**

Submitted by: Dr. Surendra N. Tiwari  
1993 NASA/ASEE Program Co-Director

Prepared by: Deborah B. Young  
ASEE Administrative Assistant

**1993 American Society for Engineering Education (ASEE)  
Summer Faculty Fellowship Program  
Orientation Evaluation**

**STATISTICS AT A GLANCE**

19 out of 29 Orientation Evaluations were returned. This indicates a 66% rate of return.

**A. Overall Organization**

- 1 - 0% Poor
- 2 - 0% Fair
- 3 - 0% Average
- 4 - 32% Good
- 5 - 74% Excellent

**B. Pre-Conference Notification**

- 1 - 0% Poor
- 2 - 5% Fair
- 3 - 0% Average
- 4 - 47% Good
- 5 - 47% Excellent

**C. Information and Knowledge Gained**

- 1 - 0% Poor
- 2 - 0% Fair
- 3 - 16% Average
- 4 - 37% Good
- 5 - 47% Excellent

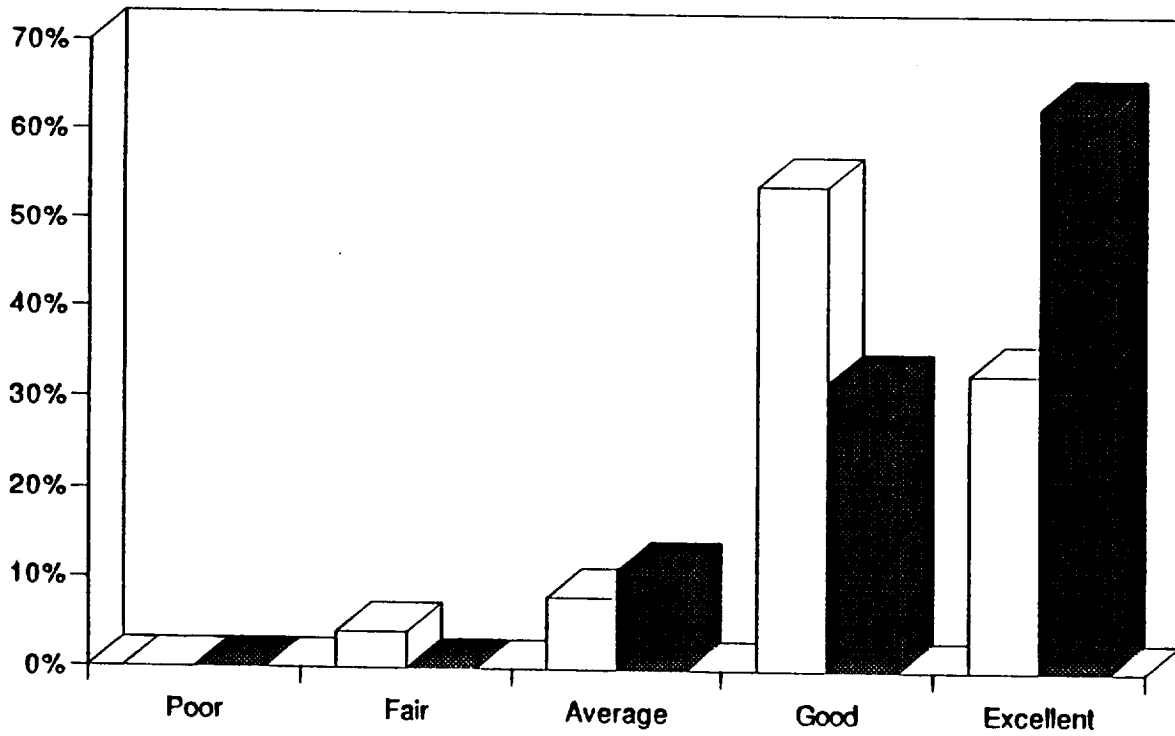
**D. Program Breakout Session**

- 1 - 0% Poor
- 2 - 5% Fair
- 3 - 0% Average
- 4 - 37% Good
- 5 - 58% Excellent

**E. General Orientation Rating**

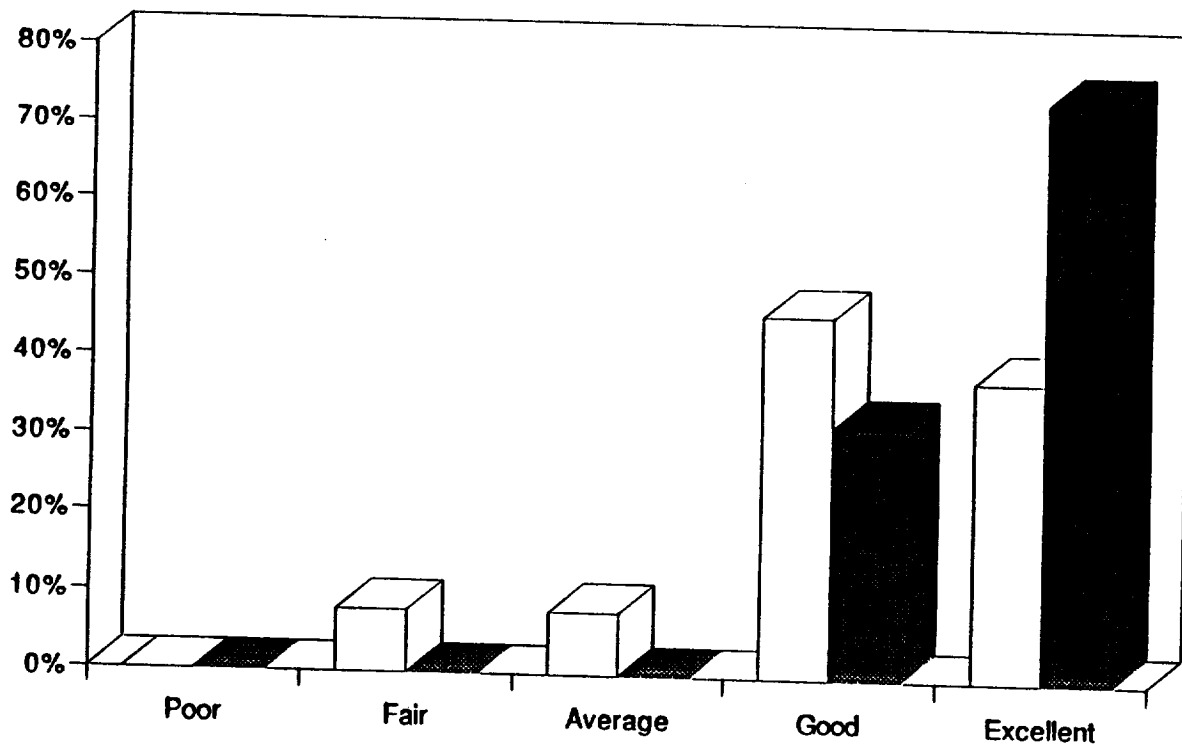
- 1 - 0% Poor
- 2 - 0% Fair
- 3 - 11% Average
- 4 - 32% Good
- 5 - 63% Excellent

### GENERALL ORIENTATION RATING 1992-1993



□ 1992 Stats   ■ 1993 Stats

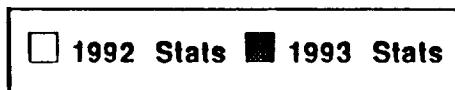
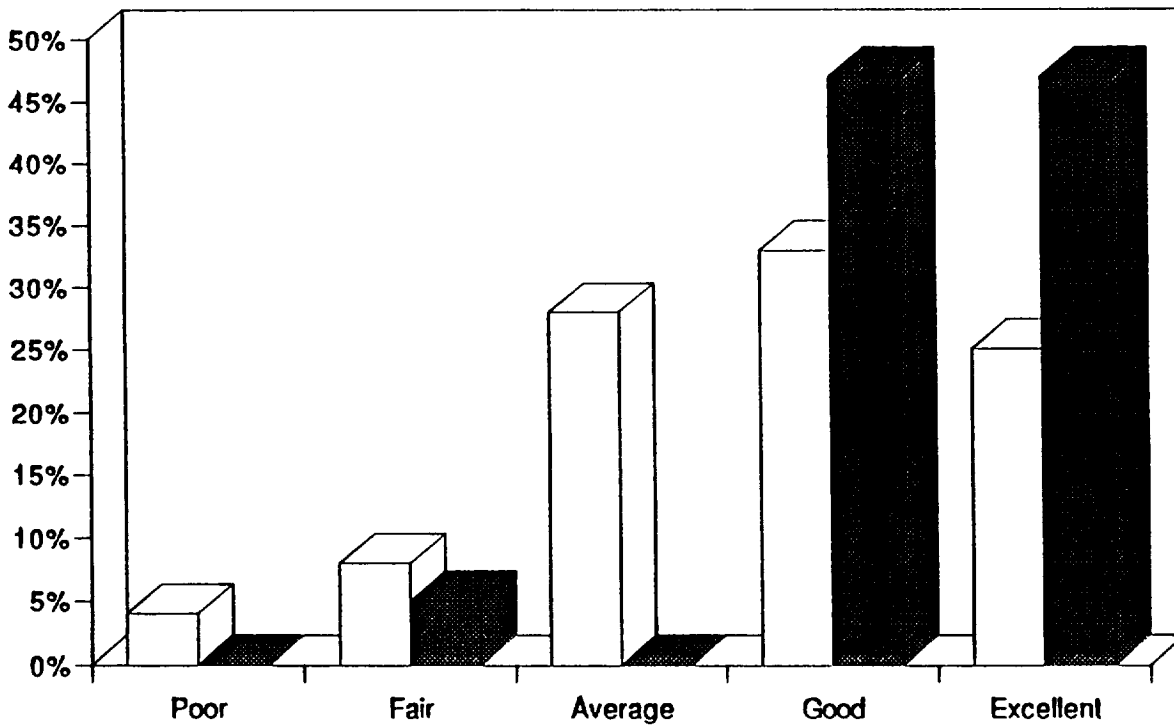
### OVERALL ORGANIZATION 1992-1993



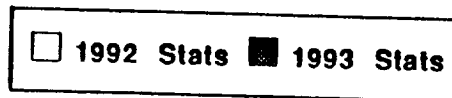
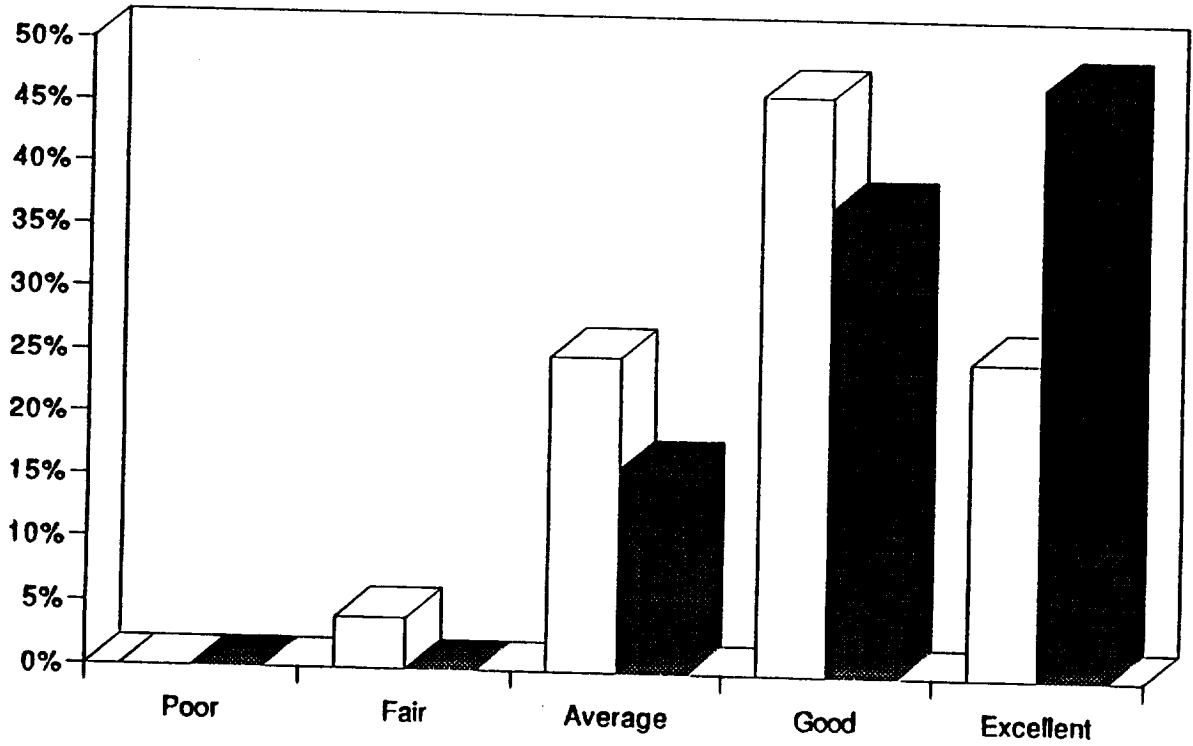
□ 1992 Stats   ■ 1993 Stats



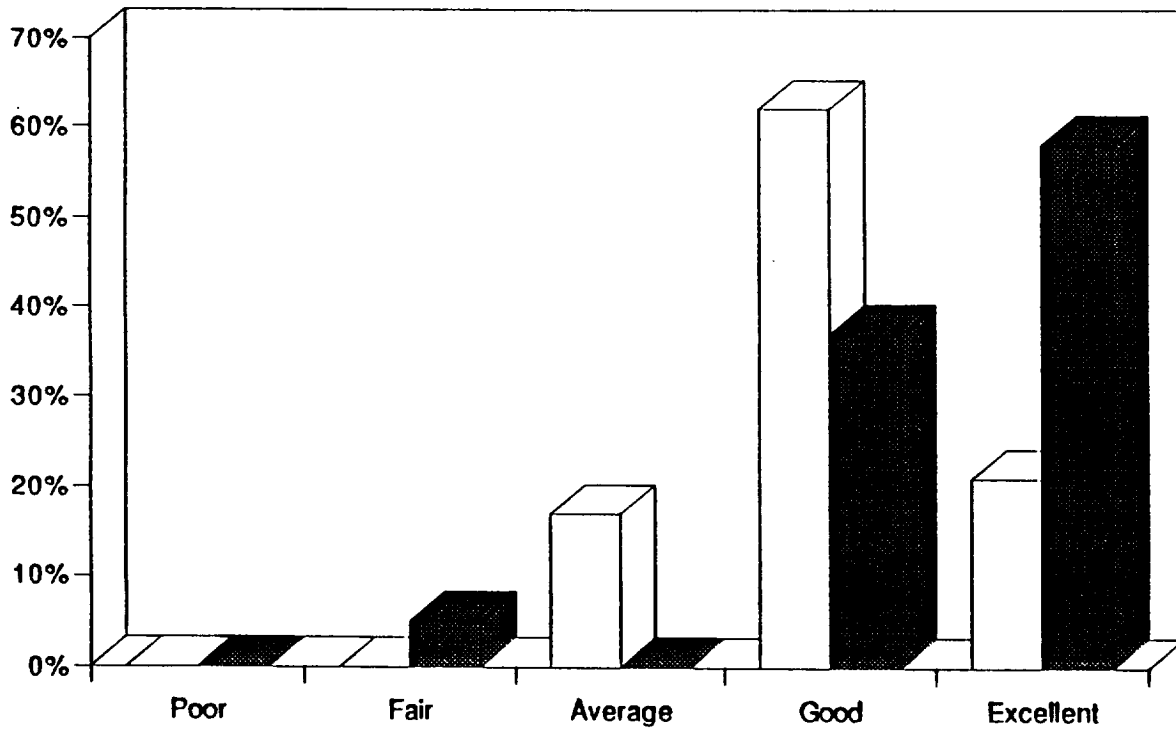
### PRE-CONFERENCE NOTIFICATION 1992-1993



## INFORMATION AND KNOWLEDGE GAINED 1992-1993



**PROGRAM BREAKOUT SESSION 1992-1993**



□ 1992 Stats   ■ 1993 Stats

**1993 American Society for Engineering Education (ASEE)  
Summer Faculty Fellowship Program  
Orientation Evaluation Comments  
June 7, 1993**

**A. Overall Organization**

Program started on time and moved at a good pace.  
The packet answered most of my questions.

**B. Pre-Conference Notification**

My letter from the program head helped me to know what to expect.  
I met with my Associate early so I could begin work the first week of the session on my tasks.

**C. Information and Knowledge Gained at the Orientation**

No comments.

**D. Program Breakout Session**

More question and answer time would be helpful.  
The tour added a lot.

**E. In General How Do You Rate This Orientation**

Greatly improved over last year.  
Information on taxation would have been helpful.

**Remarks**

Interesting and Informative.  
Everyone was pleasant.  
Well Done!  
I suggest ASEE Fellows be given a roster so we can get to know one another.  
I would not change a thing.  
Encourage participants to meet each other using self introductions.  
Evaluation should have specific questions regarding the tour.  
Tours crowded-smaller groups.  
More Q & A time for those who want it and let others leave.  
Map of the LaRC area and LAFB indicating important places (i.e. - post office, etc.) would be great.

**1993 American Society for Engineering Education (ASEE)  
Summer Faculty Fellowship Program  
Orientation Evaluation  
Recommendations**

1. Allow for more Question and Answer time during the breakout session.
2. In the information packet, provide a more detailed map of LaRC indicating important areas (i.e.-credit union, post office/mail room/mail boxes, cafeteria, etc.).
3. Smaller tour groups.
4. Add tour questions to the orientation evaluation questionnaire.

**APPENDIX XII**  
**UNSOLICITED PROPOSAL SEMINAR EVALUATION REPORT**

# 1993 UNSOLICITED PROPOSAL SEMINAR EVALUATION REPORT

## STATISTICS AT A GLANCE

Thirteen Seminar evaluations were returned.

### **A. Timely Notification**

- 1 - Poor - 0%
- 2 - Fair - 8%
- 3 - Average - 0%
- 4 - Good - 42%
- 5 - Excellent - 50%

### **B. Presentation Clear and Concise**

- 1 - Poor - 0%
- 2 - Fair - 0%
- 3 - Average - 0%
- 4 - Good - 15%
- 5 - Excellent - 85%

### **C. Speakers Having Good Command**

- 1 - Poor - 0%
- 2 - Fair - 0%
- 3 - Average - 0%
- 4 - Good - 8%
- 5 - Excellent - 92%

### **D. Information and Knowledge Gained**

- 1 - Poor - 0%
- 2 - Fair - 0%
- 3 - Average - 0%
- 4 - Good - 49%
- 5 - Excellent - 61%

### **E. Panelist Responses**

- 1 - Poor - 0%
- 2 - Fair - 0%
- 3 - Average - 0%
- 4 - Good - 23%
- 5 - Excellent - 77%

### **F. Overall Organization**

- 1 - Poor - 0%
- 2 - Fair - 0%
- 3 - Average - 0%
- 4 - Good - 15%
- 5 - Excellent - 85%

## **1993 UNSOLICITED PROPOSAL SEMINAR EVALUATION REPORT**

### **Remarks**

Should be earlier.

Should be 5 to 7 weeks into the summer.

Could have been a little earlier so we could be better preparing technical monitors for possible grants.

Very informative.

The seminar was definitely worth attending.

I learned a lot.

Extremely practical and helpful to future PI's.

Bring in some experts in NASA on the panel who have received proposals.

They may be able to give some ideas for successful proposal writing.

### **Recommendations**

1. Have the seminar about mid way through the program.
2. Invite NASA experts who have reviewed proposals to discuss what they look for.
3. Invite the Fellows' grants officers from their institutions and possibly, their deans.



**APPENDIX XIII**  
**POLICIES, PRACTICES, AND PROCEDURES MANUAL**

**NASA Langley Research Center  
American Society for Engineering Education (ASEE)  
Summer Faculty Fellowship Program**

**1993.1 POLICIES, PRACTICES,  
AND  
PROCEDURES MANUAL**



**A Handbook for ASEE Participants**

## Table of Contents

Introduction .....	ii
Definitions .....	1
Accepting a Fellowship and Beginning Tenure .....	2
Stipend .....	3
Relocation Allowance and Travel .....	4
Insurance .....	5
Taxes .....	5
Leave .....	6
Housing .....	7
Technical Lecture Series .....	7
Activities Committee .....	7
Security .....	8
Occupational Health Services .....	8
Mail Room .....	9
Library .....	10
Cafeteria .....	11
Activities Center .....	11

## **Introduction**

---

Since 1964, the National Aeronautics and Space Administration (NASA) has supported a program of summer faculty fellowships for engineering and science educators. In a series of collaborations between NASA research and development Centers, colleges, and universities, engineering and science faculty members spend ten weeks working with professional peers on research.

The ASEE Program is administered by a collaborating university. Either a Co-Director from Old Dominion University or Hampton University, on alternate years, works with the NASA LaRC University Affairs Officer, who is the Technical Monitor.

Three primary elements of the ASEE Program are (1) a research project in cooperation with a NASA Associate, (2) a study program consisting of technical lectures and seminars given by distinguished scientists and engineers from NASA, education, or industry, and (3) a technical presentation and paper. Additional elements of this program include tours of LaRC wind tunnels, computational facilities, and laboratories. Library and computer facilities will be available for all participants.

The objectives of the program are (1) to further the professional knowledge of qualified engineering and science faculty members, (2) to stimulate an exchange of ideas between teaching participants and employees of NASA, (3) to enrich and refresh the research and teaching activities of participants' institutions, and (4) to contribute to the research objectives of the Center.

The Policies, Practices, and Procedures Manual sets forth the conditions of your award, your responsibilities as an ASEE Fellow, and the procedures observed by the Universities and the University Affairs Office (UAO) in supporting and implementing your summer research program.

## **1.0 Definitions**

---

### **1.1 ASEE Summer Fellow**

As an ASEE Summer Fellow you are a faculty member, competitively selected by the Langley Directorates in a national competition, who has been offered a fellowship to perform scholarly research on a problem of interest to NASA Langley Research Center in the ASEE Summer Faculty Fellowship Program.

You enjoy the status and privileges of a guest summer faculty Fellow at LaRC. You are not an employee of LaRC or the sponsoring Directorate and do not perform personal services for either organization.

### **1.2 Langley Research Center**

For the purposes of the ASEE Program, the terms "Center" and "LaRC" are used to refer to NASA's Langley Research Center.

### **1.3 ASEE Associate**

An ASEE Associate is the scientist or engineer at the Center with whom you will work most closely. All matters relating to your research program will fall under his or her purview. The Associate also assists, as needed, in securing space, equipment, or technical support.

### **1.4 ASEE Co-Director**

The ASEE Co-Director from Old Dominion University (ODU), working in conjunction with the LaRC University Affairs Officer as Technical Monitor, is responsible for the proper administration of the ASEE Program. The Co-Director is available to discuss all aspects of the program with you, and he is your prime contact person in the UAO.

### **1.5 ASEE Administrative Assistant**

The ASEE Administrative Assistant is a support-staff member working closely with the ASEE Co-Director in the administration of the program, and acting as his representative in his absence. The Administrative Assistant is also available to answer any questions.

### **1.6 Approval**

Throughout this handbook, various procedures are cited that require the approval of the Co-Director. The use of the word "approval" means written approval. Any document requiring the Co-Director's approval will have the concurrence of the appropriate Associate. Any actions taken on the basis of

verbal concurrence are not binding on the Co-Director unless followed by appropriate written authorization.

## **2.0 Accepting a Fellowship and Beginning Tenure**

### **2.1 Notification of a Fellowship**

You will be notified of your ASEE Fellowship by an official selection letter that states the conditions of your fellowship, information concerning your stipend, and the period of your tenure at LaRC.

### **2.2 Acceptance Letter**

Once you receive your selection letter, please notify us of your decision to accept or decline the fellowship not later than the date specified in your award letter. If your acceptance letter is not received by the specified date, your fellowship may be withdrawn.

If you are requesting an alternate start or end date, please do so in your acceptance letter. The approval of both the Co-Director and the Directorate with whom you will be working is required before your tenure may officially begin. These approvals are necessary to ensure compliance with the Center's scheduling of research and its availability of support facilities.

You must also return the completed Form 531 in order to facilitate a security background check.

### **2.3 Information Package**

Included with your selection letter is an Information Package. The purpose of this package is to provide you with information which will facilitate your stay at LaRC. Included in this package is the following:

- (a) Policies, Practices, and Procedures Manual
- (b) Name Check Request, NASA Form 531 and Sample
- (c) LaRC Vehicle Code Brochure
- (d) NASA Fact Sheet
- (e) Map of the Area
- (f) Directions to NASA
- (g) Housing Information
- (h) Brochures for Area Attractions
- (i) Travel Expense Voucher
- (j) Tentative Timeline
- (k) Return Envelope

## **2.4 Working with the ASEE Associate**

You are expected to maintain close contact with your assigned Associate who will offer guidance in all aspects of your technical activities and assistance in acquiring research support facilities.

## **2.5 Change of ASEE Associate**

If for any reason your assigned ASEE Associate changes, you must notify the Co-Director immediately in writing. The change will not be effective until the Co-Director and UAO have concurred with the request.

## **2.6 Conforming to Center Policies**

ASEE Fellows are expected to conform to all established policies and procedures of the sponsoring Center as they pertain to guest researchers and the safety and health of individuals working at the Center.

## **3.0 Stipend**

---

### **3.1 Stipend Amount**

The amount of your stipend is \$1,000.00 per week. Stipends are paid on the basis of a 5-day work week and are issued bi-weekly, beginning the second Friday of the ASEE Program. Therefore, all ASEE Fellows should be prepared to provide for themselves financially the first two weeks of the program (Refer to Section 4.0).

### **3.2 Acceptance Letter**

Your acceptance letter must be received by the Co-Director before stipend payments can be authorized.

### **3.3 Locator Form**

In your orientation package you receive on the day of your arrival, you will receive a Locator Form. This form must be completed and returned to the Administrative Assistant as soon as possible following your arrival. On this form, you will be requested to supply your local address and phone number, a person to contact in case of an emergency, and your actual physical location on Center, including Mail Stop, building number, room number, and extension. **This office should be notified immediately if any changes are made once this form has been turned in.**

### **3.4 Receiving Stipend Payments**

Your biweekly stipend payments are not available for deposit by electronic funds transfer (EFT). They must be picked up in person from the ASEE Administrative Assistant. In order to receive your stipend payment, you must bring your badge for proof of identification and sign the form confirming receipt of payment.

Final stipend payment will be made only after you have submitted your Final Report, the Program Questionnaire, the Final Report Forms, the Final Checkout Form with appropriate signatures, your badge and pass, and any additional information required. If you will not be on Center the last day when stipend checks are available, submit to the Co-Director a signed memo indicating the address to which your check is to be mailed.

### **3.5 Langley Federal Credit Union (LFCU)**

LFCU has agreed to offer you stipend check cashing privileges. Due to their policy, you will be unable to open an account or cash personal checks.

## **4.0 Relocation Allowance and Travel**

---

### **4.1 Relocation Allowance**

A relocation allowance of \$1,000 will be provided to any Fellow whose home address is more than 50 miles from NASA Langley Research Center. This is provided to assist in the additional expenses incurred in relocating to the Tidewater area. No additional receipts are required.

### **4.2 Travel Reimbursement**

Fellows are reimbursed for their travel under the following terms:

- Round trip coach air fare (receipt required) or,
- Round trip mileage up to the cost of coach air fare.

Meals and overnight accommodations are the Fellow's responsibility. The travel expense form provided in this package should be filled out and returned to the Administrative Assistant at the Orientation in order to ensure prompt processing. Both the relocation allowance and travel reimbursement will be provided at the next pay date following submission of your information if time allows.



## **5.0 Insurance**

---

### **5.1 Health and Medical Insurance**

It is the responsibility of the ASEE Fellow to have the appropriate health and medical insurance coverage. The ASEE Program does not provide any insurance coverage. Experience has shown that coverage for you and your dependents is extremely beneficial. Unless you already have insurance coverage, you are advised to weigh carefully the cost/risk factor in reaching a decision to participate in this program.

### **5.2 Worker's Compensation Type Insurance**

ASEE Fellows are not covered by any type of Worker's Compensation Insurance through the ASEE Program. If injured while on duty, however slight, immediately notify your Associate and the Co-Director at (804) 864-5215. Medical help is provided in the Clinic-Occupational Health Services Facility. Hours of operation are from 7 a.m. to 4:30 p.m. In any medical emergency, dial extension (804) 864-2222 or go directly to Building 1149.

### **5.3 Automobile Insurance and Driver's License**

You must have a valid driver's license, automobile insurance, and a current inspection sticker certifying your automobile is safe.

## **6.0 Taxes**

---

### **6.1 Federal Tax Liability of United States Citizens**

Since you are not an employee of NASA LaRC or ODU, but are an ASEE Fellow and considered self employed, neither the UAO nor ODU withhold taxes from stipend payments to you. You will receive from the university, a form 1099 indicating your total stipend.

You should refer to the pertinent tax publications and plan ahead to meet any tax obligations, both federal and state, if applicable, and file your returns as required by Federal law. The responsibility for the payment of your income taxes rests solely with you. The UAO and ODU cannot provide information or consultation concerning income taxes.

### **6.2 Social Security Taxes**

Since you are not an employee of NASA LaRC or ODU, but are an ASEE Fellow and considered self employed, neither the UAO nor ODU withhold Social Security Taxes from your stipend payments. You should refer to the pertinent publications on Social Security Taxes to determine whether you have incurred any tax obligation. Although Social Security Taxes are not

withheld from stipend payments, you are nonetheless required to have an assigned Social Security Number.

### **6.3 State Tax Liability**

You may be liable for state income taxes and should file the appropriate tax return in compliance with the laws of the state in which you reside. You should consult a local government tax authority at the beginning of tenure for further details concerning this liability.

## **7.0 Leave**

---

### **7.1 Leave**

As a guest researcher in the ten-week ASEE Program, you are not eligible for annual leave, sick leave, or personal leave.

If there are reasons why you need to be absent from work during the summer research experience, there are a few steps you must take **prior** to the absence. First, you must clear this absence with your LaRC Associate. Next, submit a memo to the ASEE Co-Director indicating your Associate's concurrence, requesting approval for your absence. This is to include any conferences or presentations of papers. If this absence is directly related to your summer research and a memo to that effect is submitted by your Associate, then time approved can be considered a part of your ten week tenure. If you are approved to attend a conference not related to your summer research, then the time away **must be made up** before receiving your final stipend check. **If you are aware, prior to the start of the summer program, of a meeting or conference you desire to attend during the ten-week period, we ask that you request approval for this absence as soon as possible to allow for timely processing.**

### **7.2 Work Hours**

The typical work schedule is from 8 a.m. to 4:30 p.m. Once you arrive on Center, you will need to conform to the schedule applicable to your Division, as schedules may vary.

### **7.3 Working After Hours**

In order for you to work after hours, several steps must be taken. You must first have the approval of your Associate. Your Associate must submit to security a request for you to work after hours. Also, your Form 531 and the background check must have been completed.

## **8.0 Housing**

### **8.1 Housing Package**

The ASEE Office provides information on short-term leasing to those Fellows who require housing while in the ASEE Program. Included with your award letter is a Housing Package with pertinent information.

### **8.2 Disclaimer**

It is the Fellow's responsibility to contact the apartment complex, etc., to finalize all housing arrangements. You are strongly encouraged to make these arrangements as early as possible since short term leases are in great demand during the summer due to the influx of people into the area. **Neither ASEE, NASA, ODU, nor any staff representatives shall intercede in the lease agreement made between the tenant and the landlord.** This information is provided for the sole purpose of assisting you in making your transition to the Tidewater area easier. Once again, the only form of financial assistance provided for your housing is the relocation allowance (See Section 4.1). It is recommended that as soon as you know your departure date, you submit this information **in writing** to the complex management.

## **9.0 Technical Lecture Series**

### **9.1 Attendance**

Weekly attendance at the Technical Lecture Series by all Fellows is **strongly** encouraged. The purpose of the Lecture Series is to expand the knowledge of the professors with hopes of enhancing their classroom teaching and to give a greater knowledge of NASA's special research activities being conducted at the Center.

### **9.2 Distribution of Information**

The weekly Lecture Series will also be used as an avenue to distribute pertinent program information.

## **10.0 Activities Committee**

A voluntary activities committee will be formed at the onset of the program. This committee will plan various after work activities for the Fellows and their families. Participation in any activity is solely on a voluntary basis, and neither NASA nor Old Dominion University assume any responsibility for any events.

## **11.0 Security**

---

### **11.1 Badge and Pass Office**

Personnel from the Security Office will be processing applications for temporary visitor badges. Badges will be distributed at the orientation.

### **11.2 Langley ASEE Summer Faculty Fellows**

Each ASEE participant must show proof of their identity before a badge is provided (i.e. - driver's license).

## **12.0 Occupational Health Services**

---

### **12.1 Safety Program**

The objective of this program is to ensure each Fellow a safe and healthful working environment that is free from unacceptable hazards which could result in property damage, injury, or loss of life. The Langley Safety Manual is a compilation of documents which sets forth procedures pertinent to the safety operations of the Langley Research Center.

Each facility/building has a designated Facility Safety Head and Facility Coordinator (published in the LaRC Telephone Directory) responsible for ensuring adherence to safety rules and regulations.

### **12.2 Hazardous Communications Training**

All Fellows are required to receive Hazardous Communications Training. This training provides awareness of dealing with chemicals which are physical or health hazards.

### **12.3 Safety Clearance Procedures**

These procedures are used to ensure personnel or equipment safety during installation, maintenance, or in any situation where an equipment configuration must be temporarily maintained for the protection of personnel or equipment. The red-tag may be placed upon any device which could, if actuated, cause personnel or property to be endangered. The red-tag may also be used to forbid entrance to dangerous areas.

No person, regardless of position or authority, is to operate any switch, valve, or equipment which has a red-tag attached to it, nor will such tag be removed except as directed by an authorized authority.

## **12.4 Accident Reporting**

Fellows shall immediately report all job-related accidents, injuries, diseases or illnesses to the supervisor and the Risk Management Branch, Systems Safety, Quality and Reliability Division (SSQRD), (804) 864-SAFE ((804) 864-7233).

Obtain medical treatment from the Occupational Medical Center, Building 1149, or call extension (804) 864-2222 for emergency medical assistance.

## **12.5 Personnel Certification**

It is LaRC policy to certify Fellows performing tasks which could be potentially hazardous to either the individual, or co-workers. These requirements vary with the type of activity being performed, and consequently are described in detail in the LaRC Safety Manual dealing with the specific topic/hazard.

Particular research assignments may require training, certification, and medical surveillance requirements. Examples of these types of research assignments are chemical, radiation and/or pyrotechnic operations.

## **13.0 Mail Room**

---

### **13.1 Official Mail**

The LaRC mail system is only to be used for official mail. All offices are assigned a Mail Stop to which mail is routed. ASEE Fellows typically share a Mail Stop with their Associates. Two mail deliveries are made each day to in/out boxes located near the mail stop custodian. Distribution of packages and boxes which are too large for internal mail distribution are made to a designated table located in each facility.

Messenger envelopes are used to send mail internally. Before placing the envelope in the mail system cross out the previous name and Mail Stop, fill in the addressee's name and Mail Stop. Internal mail can not be delivered without a Mail Stop.

If you change your work site, it is your responsibility to complete NASA Langley Form 41, "Langley Research Center (LaRC) Directory Change Notice," (located in the back of the Langley Telephone Directory). This form is used to place your name on internal mailing lists, and is necessary that this information be kept up-to-date.

## **13.2 Personal Mail**

Personal mail may be placed in the U.S. Post Office boxes located in front of the Cafeteria and Langley Federal Credit Union. Additionally, the Langley Exchange Shop, located in the cafeteria, will mail your personal packages.

### **13.3 Additional Items to Remember:**

- Do not use official Government envelopes for personal mail.
- For fastest delivery by the post office; address envelopes in all capital letters, no punctuation, and use state abbreviations.
- Each piece of outgoing mail requiring postage must be stamped with the mail stop of the originating organization for identification.
- Do not use NASA Langley Research Center as a mailing address for personal mail.
- Do not send personal mail (cards, chain letters, job resume, etc.) in the internal mail delivery system.
- When addressing messenger envelopes, use first and last name. Do not use nicknames.
- Do not use room numbers in place of mail stops on messenger envelopes.
- Mail Stops are required for delivery of internal mail.

If you have any questions, please call the Mail Manager, (804) 864-6034.

## **14.0 Library**

The NASA Langley Technical Library holds more than a million titles, including books, documents, journals, and audiovisual materials. Coverage is limited to the areas of aeronautics, space science and technology, engineering, physics and chemistry, electronics and control, structural mechanics and materials, atmospheric sciences, computer science, and administration and management.

To attain access to library services, the employee's name must be listed on the official ASEE and LARSS rosters issued by the University Affairs Office. Basic services include literature searches on NASA RECON and CD-ROM databases, photocopying, and the loan of books and documents. All loan materials are due in the library two weeks prior to the conclusion of the program.

## **15.0 Cafeteria**

---

### **15.1 NASA Exchange Cafeteria**

Location:	16 Taylor Drive, Building 1213
Hours of Service:	Monday thru Friday
Breakfast:	6:15 a.m. - 8:15 a.m.
Lunch:	10:45 a.m. - 1:15 p.m.
Holidays:	Closed

### **15.2 Additional Items to Remember**

Busiest Time: 11:30 a.m. to 12:15 p.m.

Reservations: None Accepted between 11:30 a.m. to 12:30 p.m.  
Large groups after 12:30 p.m.

### **15.2 Check Writing Policies**

Maximum amount checks are cashed for is \$20.00. Participants must have a badge and obtain management approval.

### **15.3 Area Tickets Available**

Discount tickets for Busch Gardens, Water Country, Kings Dominion, AMC Theaters, and Colonial Williamsburg can be obtained at the Exchange Shop in the Cafeteria. If you are interested in tickets, call (804) 864-1585.

## **16.0 Activities Center**

---

### **16.1 Conference Center**

The Conference Manager serves as a consultant and advisor for conferences and technical meetings. Reservations can be made for the auditorium, the Langley, Hampton, and Wythe Rooms in Building 1222 at 14 Langley Boulevard through the Conference Manager. Also, there are conference Centers at 3 S. Wright Street and Room 200 in the 7 x 10 Facility at 17 W. Taylor Road. For reservations, call (804) 864-6362.

## **16.2 Picnic Shelters**

There are two picnic shelters on the grounds of the Reid Conference Center that can be reserved for office picnics. You are welcome to use a table anytime one is available. For reservations, call (804) 864-6369.

## **16.3 LaRC-sponsored clubs:**

Aerobic Club  
Astronomy Club  
Conservation Club  
History and Archeology Club  
Radio Model Club  
Science Fiction Club  
Tennis Club

Amateur Radio Club  
Bass Club  
Garden Club  
Karate Club  
Runners Club  
Softball League  
Volleyball League

## **16.4 Additional Information**

If you would like to see exhibits on NASA or view the featured film in an IMAX theater, you can visit the new Virginia Air and Space Center in downtown Hampton.



REPORT DOCUMENTATION PAGE			Form Approved OMB No. 0704-0188	
Public reporting burden for this collection of information is estimated to average 1 hour per response, including the time for reviewing instructions, searching existing data sources, gathering and maintaining the data needed, and completing and reviewing the collection of information. Send comments regarding this burden estimate or any other aspect of this collection of information, including suggestions for reducing this burden, to Washington Headquarters Services, Directorate for Information Operations and Reports, 1215 Jefferson Davis Highway, Suite 1204, Arlington, VA 22202-4302, and to the Office of Management and Budget, Paperwork Reduction Project (0704-0188), Washington, DC 20503.				
1. AGENCY USE ONLY (Leave blank)	2. REPORT DATE December 1993	3. REPORT TYPE AND DATES COVERED Contractor Report-June 7-Aug 13, 1993		
4. TITLE AND SUBTITLE 1993 NASA-ODU American Society for Engineering Education (ASEE) Summer Faculty Fellowship Program			5. FUNDING NUMBERS G NGT-47-003-029	
6. AUTHOR(S) Surendra N. Tiwari and Deborah B. Young (Compilers)				
7. PERFORMING ORGANIZATION NAME(S) AND ADDRESS(ES) Old Dominion University Norfolk, VA 23508			8. PERFORMING ORGANIZATION REPORT NUMBER	
9. SPONSORING/MONITORING AGENCY NAME(S) AND ADDRESS(ES) National Aeronautics and Space Administration Langley Research Center Hampton, VA 23681-0001			10. SPONSORING/MONITORING AGENCY REPORT NUMBER NASA CR-191544	
11. SUPPLEMENTARY NOTES Langley Technical Monitor - Robert L. Yang				
12a. DISTRIBUTION/AVAILABILITY STATEMENT Unclassified - unlimited Subject Category - 80			12b. DISTRIBUTION CODE	
13. ABSTRACT (Maximum 200 words) Since 1964, the National Aeronautics and Space Administration (NASA) has supported a program of summer faculty fellowships for engineering and science educators. In a series of collaborations between NASA research and development centers and nearby universities, engineering faculty members spend 10 weeks working with professional peers on research. The Summer Faculty Program Committee of the American Society for Engineering Education supervises the programs. Objectives: (1) To further the professional knowledge of qualified engineering and science faculty members; (2) To stimulate and exchange ideas between participants and NASA; (3) To enrich and refresh the research and teaching activities of participants' institutions; (4) To contribute to the research objectives of the NASA center. Program Description: College or university faculty members will be appointed as Research Fellows to spend 10 weeks in cooperative research and study at the NASA Langley Research Center. The Fellow will devote approximately 90 percent of the time to a research problem and the remaining time to a study program. The study program will consist of lectures and seminars on topics of interest or that are directly relevant to the Fellow's research topics. The lectures and seminar leaders will be distinguished scientists and engineers from NASA, education, or industry.				
14. SUBJECT TERMS ASEE-NASA Summer Faculty Fellowship Program ASEE-NASA Administrative Report			15. NUMBER OF PAGES 238	
			16. PRICE CODE A11	
17. SECURITY CLASSIFICATION OF REPORT Unclassified	18. SECURITY CLASSIFICATION OF THIS PAGE Unclassified	19. SECURITY CLASSIFICATION OF ABSTRACT Unclassified	20. LIMITATION OF ABSTRACT	





