

JOSEPHSON JUNCTION SPECTRUM ANALYZER FOR MILLIMETER AND SUBMILLIMETER WAVELENGTHS

S.Y.Larkin, S.E.Anischenko, P.V.Khabayev.

State Research Center "Fonon". 37, Pobedy Ave., KPI, Kiev, 252056 Ukraine.

ABSTRACT

A prototype of the Josephson-effect spectrum analyzer developed for the millimeter-wave band is described. The measurement results for spectra obtained in the frequency band from 50 to 250 GHz are presented.

INTRODUCTION

Spectroscopic studies in millimeter-wave and submillimeter-wave bands are faced a lot of problems when the techniques initially developed for lower or higher frequencies are applied in this intermediate spectral band. On the one hand, the efficiency of heterodyne RF mixing technique decreases rapidly with the decrease of wavelength and this technique also fails to provide continuous measurements in the whole band. On the other hand, the measurements of more continuous spectra can be carried out by extending the optical techniques using diffraction gratings and Michelson interferometers to millimeter-wave band, but the efficiency of these optical techniques decreases with the increase of wavelength due to diffraction losses.

A new spectroscopic technique based on the AC Josephson effect in superconducting junctions was proposed earlier [1,2] and developed afterwards [3] and some experiments were done to estimate the applicability of this technique in general spectroscopic measurements of submillimeter-wave and millimeter-wave radiation. In this technique a frequency scanning is accomplished by changing the voltage on the junction and fast spectral measurements are in principle possible by the technique. These features are very attractive for the high-speed millimeter-wave spectra in the frequency band of 30-300 GHz and should be analyzed with rather moderate spectral resolution of 2 GHz but with characteristic time interval about 10 ms.

THEORY

When weak electromagnetic radiation with the spectral distribution of intensity $S(f)$ is applied to the Josephson junction, its current-voltage curve (I-V curve) is changed (Fig.1a). When the Josephson junction is described by the resistively-shunted-junction (RSJ) model, the difference $\Delta I(V)=I(V)-I_0(V)$ between the current values with and without incident radiation is shown to be related with the radiation spectrum by the Hilbert transform [1]:

$$S(f) \cong K \int_{-\infty}^{+\infty} \frac{g(u) du}{u - hf / 2eV} \quad (1)$$

where $g(V)=k*\Delta I(V)*I(V)*V$ is the response function (Fig.1b).

Thus, the spectral analysis consists of two parts: at first one should measure the I-V curves of the Josephson junction both with and without incident radiation and then apply the Hilbert transform to measured response function $g(V)$. A spectral line for the 70 GHz monochromatic signal obtained with the use of Hilbert transform is shown in Fig.1c. The

operational principle in some respect is similar to that of the Fourier-transform-spectroscopy. The main difference between two techniques lies in the following: for the Hilbert-transform-spectroscopy, the first integral transformation of spectrum into electric signal occurs directly in the solid-state detector, but in the FTS this transformation takes place in the detector-comprising optico-mechanical interferometer. This difference results in some advantages of the HT spectroscopy as compared with the FT spectroscopy: a potentiality of the high-speed spectroscopy is one of them.

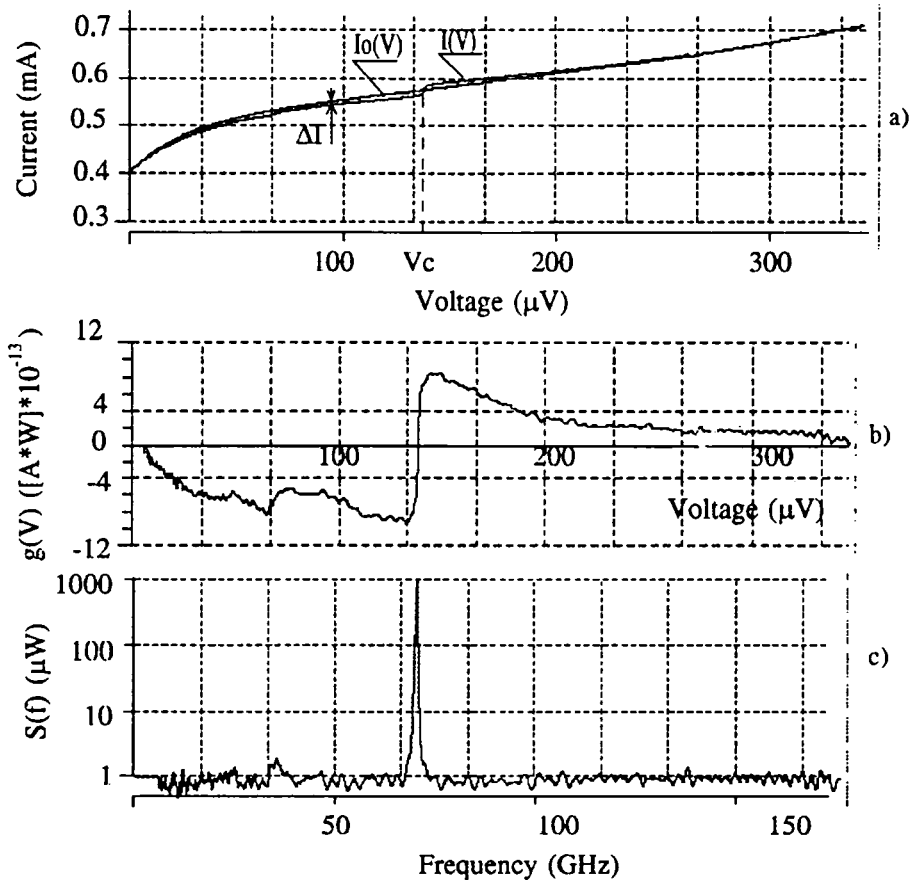

Fig.1. Spectral measurements of 70 GHz monochromatic signal

The main advantage of this technique is due to its possibility to provide the wide-band (about a decade) millimeter measurements using only one measuring channel.

The following restriction for this spectroscopic method should be mentioned. This method rests on the assumption that the amplitude of the current induced in the junction is comparable to the amplitude of the fluctuating current i_r . In this case a response of the junction can be expressed as [4]

$$resp = \frac{\bar{v} - \bar{v}^{(A)}}{a^2(\Omega)} = \frac{1}{8\bar{v}^2} \operatorname{Re} \frac{1}{\delta - j\gamma} \quad (2)$$

where: \bar{v} and $\bar{v}^{(A)}$ are respectively the voltages on the Josephson junction with and without incident radiation; $a(\Omega)$ is the amplitude of the induced current; $\Omega = 2e\bar{v} / \hbar$ is the frequency of the incident radiation; $\delta = \bar{v} - \omega$ is a mistuning for the Josephson frequency ω ; γ is a parameter characterizing fluctuations of the junction.

Analytically the response of the junction may be given as [1]:

$$\Delta i(\bar{v}, \Omega) = \frac{a^2(\Omega)}{8\bar{v}} \left[\frac{\bar{v} + \Omega}{(\bar{v} + \Omega)^2 + \gamma^2} + \frac{\bar{v} - \Omega}{(\bar{v} - \Omega)^2 + \gamma^2} \right] \quad (3)$$

The next conclusion follows herefrom. The inherent fluctuations of the Josephson junction bring into existence the quadratic change of shape of its I-V curve under weak incident radiation. That is to say that this change is proportional to square of the induced current amplitude $a^2(\Omega)$. What this means is that at first in case of weak radiation there appear a feature in shape of a bend in the I-V curve instead of the Shapiro step. This feature or a response of the Josephson junction is governed by the equation [4]:

$$resp = \frac{1}{8\bar{v}^2} \operatorname{Re} \left[\frac{1}{\omega - \bar{v} - j\gamma} - \frac{1}{\omega - \bar{v} + j\gamma} \right] \quad (4)$$

Fig.2 shows different shapes of feature of the I-V curve under changing the incident power of the harmonic radiation. From this figure we notice that within the feature region the dynamic resistance of irradiated junction varies through a range:

$$0 \leq R_d \leq R_d^{(A)} \quad (5)$$

where $R_d \cong 0$ is consistent with the Shapiro step; $R_d^{(A)}$ is a dynamic resistance of the Josephson junction without incident radiation.

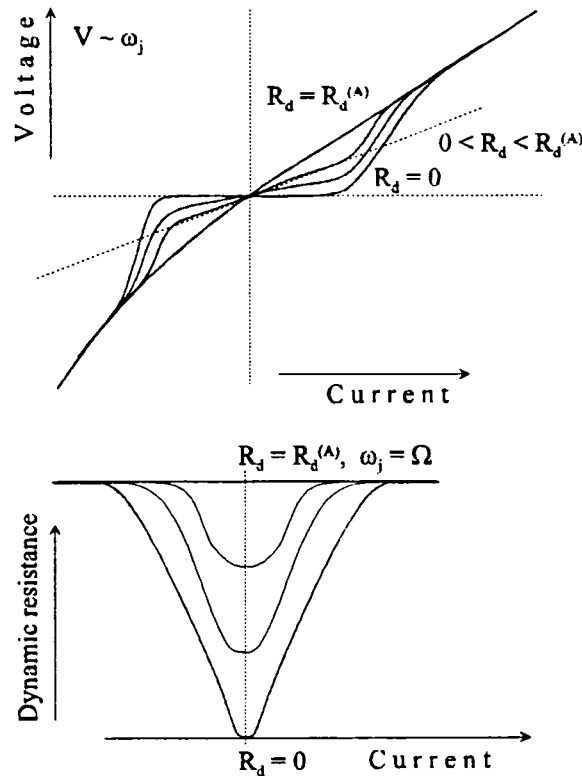

Fig.2. The dynamic resistance dependence of the incident power of harmonic radiation in the neighbourhood of the central point of the feature zone.

The implication of this analysis we use for the development of the Josephson spectrometer is that a dynamic range of the incident power is limited at the top. The induced current amplitude may not exceed a fixed quantity wherein the dynamic resistance is equal to 0. A practical implementation of this restriction is carried out by analyzing the dynamic resistance in every point of the I-V curve within a corresponding frequency range and attenuation of the incident power if the dynamic resistance becomes equal to 0.

EXPERIMENTAL SET-UP

Fig.3 shows a block diagram of the experimental set-up. The set-up consists of four main units:

1. A Cryogenic block.
2. An Analog signal processing unit.
3. A high speed communications interface with the quick DAC and ADC.
4. A quasi-optical microwave transmission line.

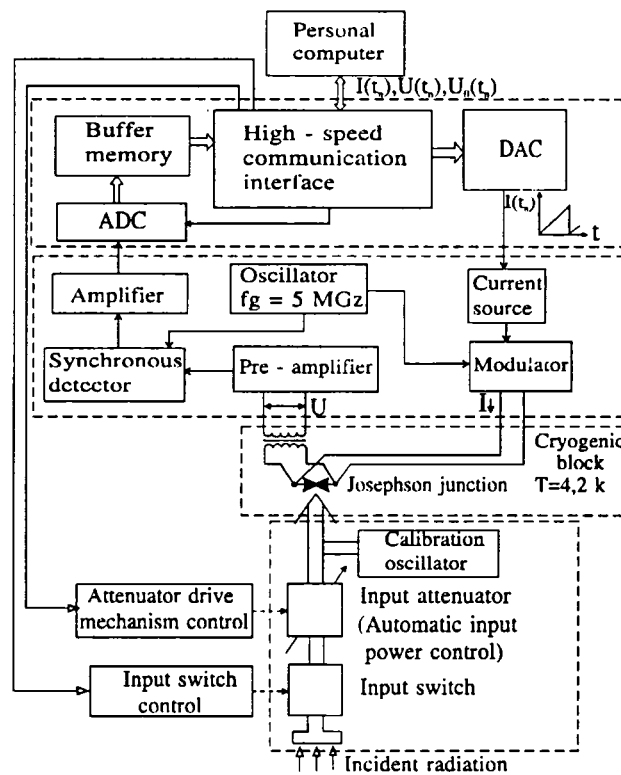

Fig.3. Block diagram of the experimental set-up.

The spectrum analyzer performance is controlled by the personal computer. Operating software for measuring the spectra depends on signal type. When studying the determinate processes the I-V curve measurements are followed by signal spectrum recovery at once. The recovery time is no more than 20 s. The spectrum calibration with respect to the frequency and power is performed by the calibrating signal which frequency is beyond the frequency range being under consideration. When quick-changed random signals such as the microwave radiation of the thermonuclear plasma are analyzed a set of the I-V curves is taken and stored in the computer memory. The time is taken for one I-V curve to be measured does not exceed 20 μs . After stopping the signal action or a

required number of the I-V curves are measured, the computer recovers the slide-spectra followed by their storage in memory.

The 14-bit DAC is controlled by the computer via the high-speed communications interface. The DAC in combination with the current source forms the current ramp $I(t_n)$ as a bias of the junction operating point. The shape of the junction response voltage $U(t_n)$ is similar to its I-V curve. This signal is amplified and sampled by the high-speed 16-bit ADC. To reduce noise the analog signals are processed at 5 MHz modulation frequency. A transformer that has a helium level of cooling is used for matching the low-resistive Josephson junction (R_n is about 1 Ohm) with the amplifier input resistance. The measured response signal is stored in a buffer memory for the time when the successive I-V measurements are made, then it is directed into the computer via the high-speed communications interface.

The spectrum is obtained by a personal computer in accordance with Eq.1 having extracted the experimental data $I(t_n)$, $V_o(t_n)$, $V(t_n)$ from its memory and using the canonical discrete Hilbert transform algorithm.

From Eq. (1) and the equations attending its derivation it follows that the canonical algorithm for Hilbert-spectroscopy prescribes execution of seven successive steps:

Step 1. Input of the sequence of counts y_2 , representing the I-V curve $y_2=f(x)$ of the junction disturbed by the external microwave signal.

Step 2. Input of the sequence of counts y_1 , representing the basic I-V curve $y_1=f(x)$ of the screened junction.

Step 3. Formation of the inverted sequence z_2 , representing the inverted I-V curve $z_2=g(y_2)$ of the disturbed junction.

Step 4. Formation of the inverted sequence z_1 , representing the inverted basic I-V curve $z_1=g(y_1)$.

Step 5. Formation of the coloring function $wgh(x)$ equal to element-by-element product of the inverted basic I-V curve by the sequence of the independent variable y counts (the segment of the natural set of numbers).

Step 6. Formation of the difference function $dz=z_2-z_1$ and its coloring to yield the form $dlt=dzx*wtgh$ suitable for transformation.

Step 7. Execution of the Hilbert transform of the coloring difference function with the transformation core size specified by the operator.

The final transformation product forms the equidistant sequence of counts of the estimated signal energy spectrum for the irradiated junction under the test determination of I-V values $y_2=f(x)$.

It should be noted that the synthesized canonical form of the Hilbert spectroscopy algorithm can be used with both non-coherent and monochromatic signals under the test conditions. For the latter, the algorithm is realized by passing Step 5 and Step 6 that foresee the difference function coloring to equalize the non-uniformity of the Josephson junction sensitivity over the operating frequency band.

Fig. 4 shows a block-schematic diagram of the microwave transmission-line. When designing this system we made a choice of the quasi-optical components due to existence of some basic problems. They are:

- wide range of frequencies being investigated, from 50 to 350 GHz;
- high frequency resolution that is about 2 GHz;
- linearity of an amplitude-frequency characteristic (bandpass flatness no more than 2 dB);
- difficulty to match the high waveguide resistance with the low resistance of the Josephson junction over a wide frequency band.

The hollow square metal-dielectric waveguide with appropriate electromagnetic focusing is utilized as a system for radiation channeling from the input antenna to the Josephson junction. The input switch and attenuator provided with the personal computer

control are employed to adjust the incident power at the Josephson junction and to take measure I-V curves of irradiated junction. The designed microwave unit allows the following parameters to be realized in the frequency range from 50 to 400 GHz:

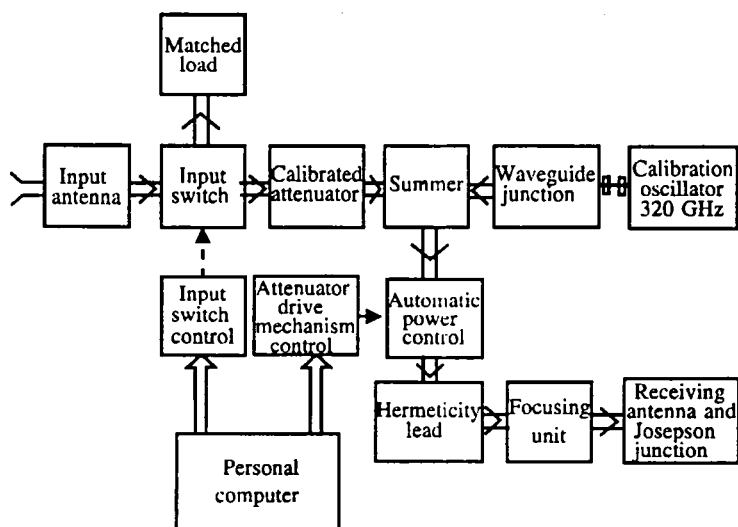

Fig.4. Block schematic diagram of the quasi-optical microwave transmission line.

- bandpass flatness of the amplitude-frequency characteristic is no more than 2 dB;
- longitudinal losses along 1.5 m are no more than 0.6 dB/m;
- attenuation at the low frequency range margin is no more than 6 dB;
- adjusting level for the input power is 50 dB.

The high-stability calibrating oscillator with the input power of $1 \mu\text{W}$ at a frequency of 320 GHz is incorporated into the microwave transmission line via the directional coupler for calibrating the spectrum analyzer during the measurement process.

Designed microwave transmission line has some advantages over the other cryogenic microwave systems. The cryogenic receiver manufactured on the basis of it allows to work with any transport Dewar flasks and simplifies procedure of preparing the cryogenic block to the measurements. The time interval for this procedure is about 2 minutes.

The matching structure was developed to match the best the low impedance Josephson junction with an impedance of the metal-dielectric waveguide within the wide frequency range [3]. This structure (see Fig. 5) consists of the planar tapered V-antenna, the impedance transformer and planar integrated low temperature niobium junction, was properly calculated and the necessary layout was designed. The antenna feed-point impedance is adjusted to the junction normal resistance of about 1 Ohm by the multi-layered structure consisting of the broadband taper between a quasi-coplanar strip line and a parallel plate line. The substrate material is a sapphire. The main parameters of the Josephson junction are:

- normal resistance is 0.5 ... 1.5 Ohm;
- critical current is 0.2 ... 0.4 ma;
- junction area is about $0.5 \mu\text{m}^2$.

The I-V curve for unperturbed junction (see Fig.6) is not similar to that of the Josephson junction in RSJ model but nevertheless Josephson behavior is observed for the frequencies within the band from 30 to 500 GHz.

The multi-layered structure appears to be a disadvantage because it is too hard to manufacture such high-temperature samples with the two-step junction or bicrystal junction that answer the best the resistively-shunted-junction model. Another disadvantage of the multi-layered structure consists in poor correspondence of the weak

superconductivity mechanism to the resistively-shunted-junction model that is a basis of our methodological approaches due to high capacitance of the junction.

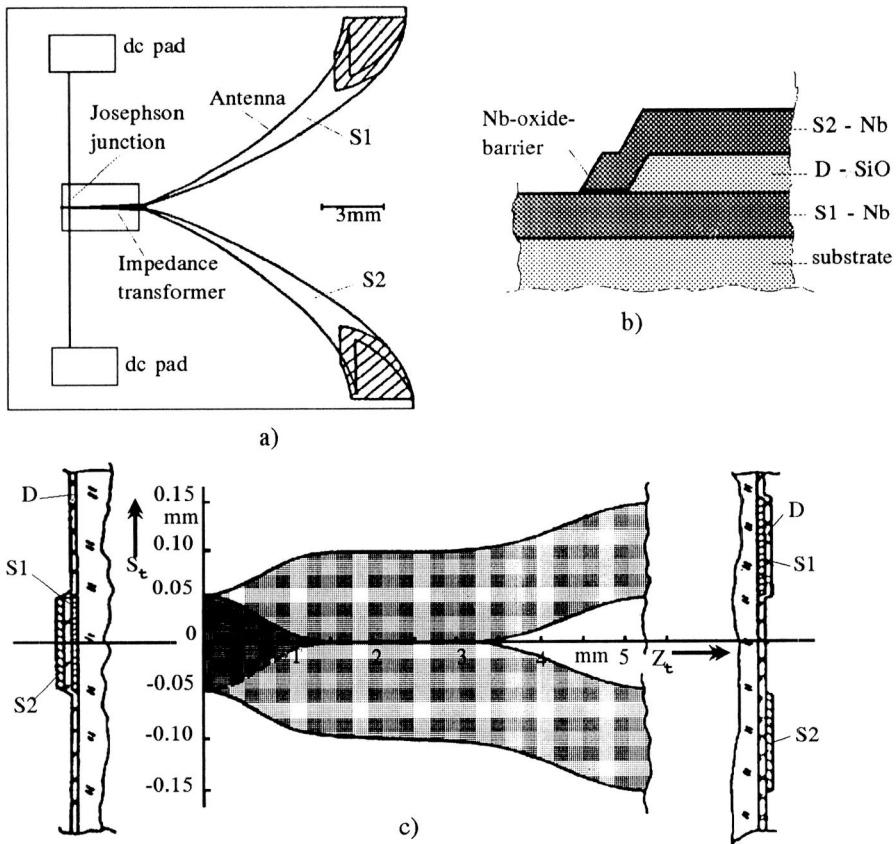

Fig.5. a) Layout of the broadband receiving antenna with the Josephson junction;
 b) Structure of the Josephson junction;
 c) Layout of the broadband impedance transformer.

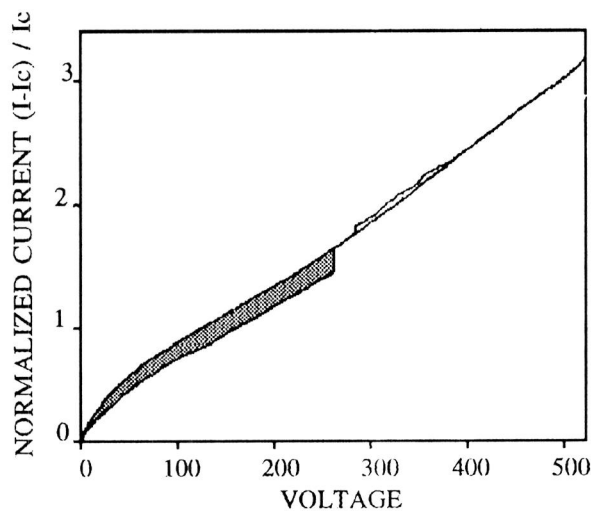

Fig.6. I-V curves of the Josephson junction with and without incident radiation.

RESULTS

The set-up described above allowed the analysis of the complex line spectra to be performed over the frequencies from 40 to 250 GHz with the frequency resolution being not worse than 2 GHz and the sensitivity being not less than 10^{-13} W/ $\sqrt{\text{Hz}}$.

The most characteristic results have been obtained when complex polyharmonic signals were passed to the spectrum analyzer input.

Fig. 7 shows the signal spectrum taken from the Josephson junction co-irradiated by the non-coherent laboratory back-ward-wave oscillators. The output power levels of the oscillators are from 0.01 to 1 mW. Therefore the attenuation level was adjusted more than 30 dB to reach the dynamic range of the junction. The frequency resolution is about 2 GHz.

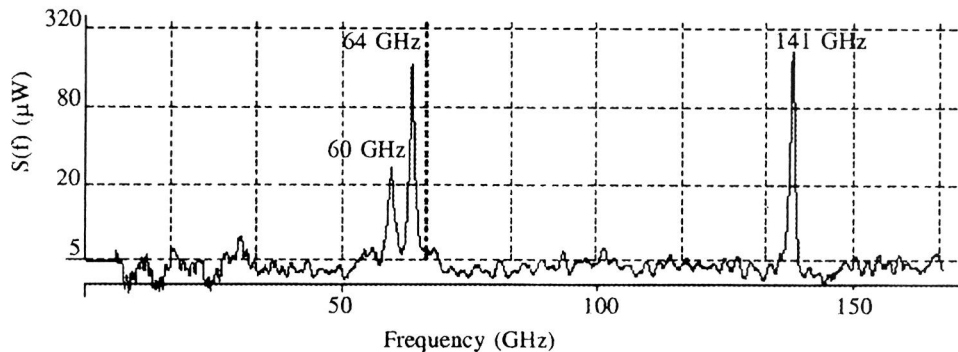

Fig.7. Spectral measurements of mixed three monochromatic signals.

Fig. 8 presents the spectrum of five non-coherent laboratory back-ward-wave oscillators.

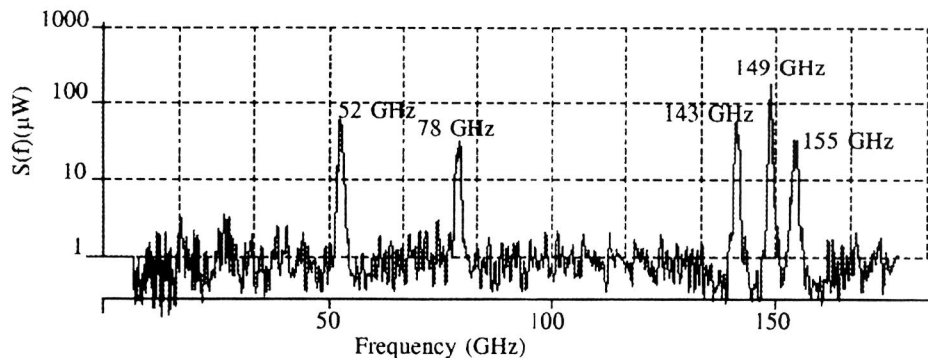

Fig.8. Spectral measurements of mixed five monochromatic signals.

Fig. 9 shows the signal spectrum obtained from the 9 GHz driving oscillator with the 14 times avalanche diode multiplier. Inspection of the spectrum reveals that its structure is vertical lines with pronounced fundamental frequency $f_m = 126$ GHz and several lateral harmonics separated by 9 GHz.

The incident power at the fundamental frequency f_m exceeds the dynamic range for the specimens of this type. Therefore, the lateral harmonics which frequencies are less than f_m , are poorly observed. This is confirmed by the I-V curve of the Josephson junction irradiated by the avalanche diode oscillator signal with the vertical line spectrum (see Fig.6). From Fig.9 it is evident that a significant nonlinearity in the initial part of the

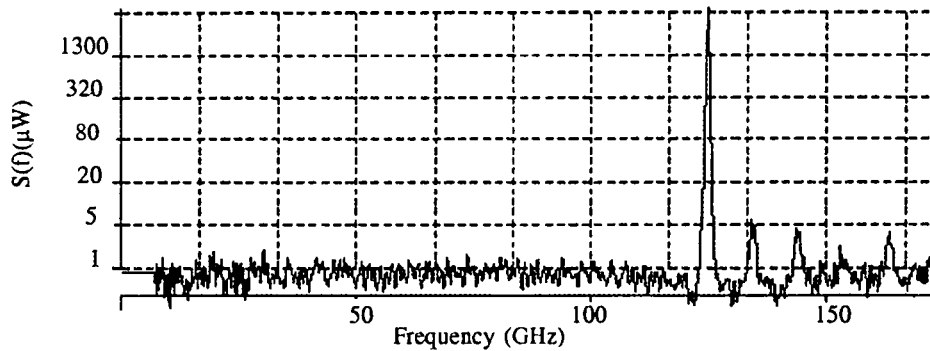

Fig.9. Spectrum of the signal obtained from the 9 GHz driving oscillator with the 14 times avalanche diode multiplier.

I-V curve leads to both the effect of the junction response signal from the frequency f_m upon those from the frequencies that are less than f_m (dashed area), and limitation of the dynamic power range up to 20 dB.

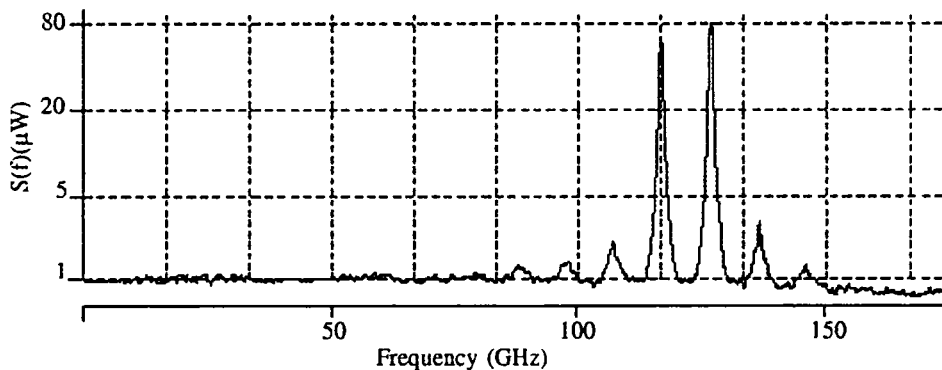

Fig.10. See text.

Fig. 10 shows the signal spectrum obtained from the same oscillator but with the notch-filter for the fundamental harmonic. In this case a dynamic range of the junction is not exceeded and the spectrum obtained really corresponds to the factual one.

REFERENCES

- [1] Yu.Ya.Divin,O.Yu.Polyanski,A.Ya.Schulman. Incoherent radiation spectroscopy by means of the Josephson effect, Sov. Tech. Phys. Lett., 1980, 6, 454-455.
- [2] Yu.Ya.Divin,O.Yu.Polyanski,A.Ya.Schulman. Incoherent radiation spectroscopy based on ac Josephson effect, IEEE Trans.Magnetics.,1983, 19, 613-615.
- [3] J.H.Hinken et al. Computer-controlled mm- & submm-wave Josephson spectrometer with planar integrated front end. Pros. 18th Europ.Microwave Conf.,1988, 177-182.
- [4] K.K.Likharev, B.T.Ulrich. Systems with Josephson Contacts. Moscow: Moscow State University Publishing House, 1978.