

Experimental Surface Pressure Data Obtained on 65° Delta Wing Across Reynolds Number and Mach Number Ranges

Volume 3—Medium-Radius Leading Edge

Julio Chu and James M. Luckring

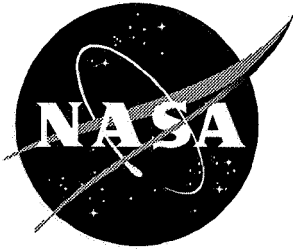

Experimental Surface Pressure Data Obtained on 65° Delta Wing Across Reynolds Number and Mach Number Ranges

Volume 3—Medium-Radius Leading Edge

Julio Chu and James M. Luckring
Langley Research Center • Hampton, Virginia

The use of trademarks or names of manufacturers in this report is for accurate reporting and does not constitute an official endorsement, either expressed or implied, of such products or manufacturers by the National Aeronautics and Space Administration.

Available electronically at the following URL address: <http://techreports.larc.nasa.gov/ltrs/ltrs.html>

Printed copies available from the following:

NASA Center for AeroSpace Information
800 Elkridge Landing Road
Linthicum Heights, MD 21090-2934
(301) 621-0390

National Technical Information Service (NTIS)
5285 Port Royal Road
Springfield, VA 22161-2171
(703) 487-4650

Summary

An experimental wind tunnel test of a 65° delta wing model with interchangeable leading edges was conducted in the Langley National Transonic Facility (NTF). The objective was to investigate the effects of Reynolds and Mach numbers on slender-wing leading-edge vortex flow with four values of wing leading-edge bluntness. The data presented in volume 3 of this report are for the medium-radius leading edge equivalent to 0.15 percent of the mean aerodynamic chord. The data for the sharp leading edge and the small- and large-radius leading edges are presented in volumes 1, 2, and 4, respectively, of this report. Experimentally obtained pressure data for the medium-radius leading edge are presented without analysis in tabulated and graphical formats across a Reynolds number range of 6×10^6 to 120×10^6 at a Mach number of 0.85, and across a Mach number range of 0.4 to 0.9 at Reynolds numbers of 6×10^6 , 60×10^6 , and 120×10^6 . Normal-force and pitching-moment coefficient plots for these Reynolds number and Mach number ranges are also presented.

Introduction

Wing leading-edge vortex flow on slender wings has been a subject of study at aeronautical research laboratories (refs. 1–6) for many years. The wing upper surface pressure loading induced by the leading-edge vortex has been shown to provide a significant vortex-lift increment at moderate to high angles of attack for slender wings. (See ref. 7.) Application of vortical flow benefits has been primarily directed toward military use for which designs have been investigated that enhance transonic maneuverability for tactical supercruisers using vortex lift (refs. 8 and 9) or that suppress the vortex flow for those conditions where it is undesirable. (See ref. 10.) However, commercial application of vortex flow is evident in the ability of the *Concorde* to achieve high lift during takeoff and landing.

The majority of previous leading-edge vortex flow studies have been conducted on sharp leading-edge wings, where the primary separation line may be assumed to be located at the leading edge. This assumption permits inviscid vortex sheet approximations in analytical modeling and should minimize the dependency of the experimental data on Reynolds number. (See refs. 3–6 and 8.) However, vortical flow investigations on blunt leading-edge wings have been less comprehensive. (See refs. 2, 3, and 11.) The flow around blunt leading edges is inherently dominated by viscous effects and presents a significant challenge for empirical, analytical, or computational analysis. The primary separation line location and the vortex strength for a blunt leading edge are known to be dependent on Reynolds number. This

sensitivity to Reynolds number also occurs with flow reattachments and subsequent development of secondary vortices regardless of leading-edge bluntness. (See refs. 10 and 12.)

Accordingly, the National Aeronautics and Space Administration (NASA) Langley Research Center (LaRC) has attempted to augment the existing database (refs. 11 and 13) for the effects of leading-edge bluntness across a broad Reynolds number range and to facilitate the development of suitable scaling techniques in characterizing the complex leading-edge flows. The approach was to investigate the basic nature of the surface pressure on a slender wing with various values of the leading-edge radius. The experiment was conducted on a planar delta wing with a leading-edge sweep of 65° across broad Reynolds number and Mach number ranges at the Langley National Transonic Facility (NTF). The model was fabricated with removable leading edges to permit testing of four leading-edge sets. The sets were designated as sharp, small, medium, and large, which corresponded to values of leading-edge radii normalized by the mean aerodynamic chord of 0, 0.05, 0.15, and 0.30 percent, respectively.

The experimental data for the medium-radius leading edge are presented in volume 3 of this report. The data for the sharp leading edge and for the small- and large-radius leading edges are presented in volumes 1, 2, and 4, respectively, of this report. Wing pressure data are presented along with normal-force and pitching-moment coefficient data. Note that the primary objective of the force measurements was to monitor the safety of the model support system during the experiment; hence, the accuracy of the force measurements was of secondary importance.

Symbols

a, b, c, d	coefficients in first-blending function ϕ (appendix A)
b	wing span, 24 in.
C_m	pitching-moment coefficient about moment reference point, $\frac{\text{Pitching moment}}{q_\infty S \bar{c}}$
C_N	normal-force coefficient, $\frac{\text{Normal force}}{q_\infty S}$
C_p	pressure coefficient, $\frac{p - p_\infty}{q_\infty}$
c_R	root chord, 25.734 in.
\bar{c}	mean aerodynamic chord, 17.156 in.

F_N	normal force, lbf
l, m, n	coefficients in second-blending function ψ (appendix A)
M_Y	pitching moment, in-lbf
M_∞	free-stream Mach number
p	local pressure, psia
p_∞	free-stream static pressure, psia
p_T	free-stream total pressure, psia
q_∞	free-stream dynamic pressure, psf
R	Reynolds number
r	local radius
S	wing area, 2.145 ft ²
t_T	total temperature, °F
U	uncertainty
x	distance from apex, positive downstream, in.
x_0	initial longitudinal coordinate of blending function ϕ , in. (appendix A)
x_1	endpoint longitudinal coordinate of blending function ϕ , in. (appendix A)
y	spanwise distance from apex, positive right, in.
z	distance above X-Y plane, positive upward, in.
α	angle of attack, deg
η	$\frac{2y}{b_1}$
ξ	nondimensional distance parameter
ϕ	first-blending function (appendix A)
ψ	second-blending function (appendix A)

Abbreviations:

ESP	electronically scanned pressure
l	lower
L.E., le	leading edge
mac	mean aerodynamic chord
NTF	National Transonic Facility
starb'd	starboard
u	upper
l	local

Facility

The test was conducted in the Langley National Transonic Facility (NTF). The facility is a fan-driven, closed-circuit, cryogenic transonic pressure wind tunnel.

(See fig. 1.) The test section is 8.2 ft high by 8.2 ft wide by 25 ft long with a slotted ceiling and floor.

The NTF operating capability has a nominal Mach number range of 0.2 to 1.2, total pressure range of 15 to 120 psia, and total temperature range of -260°F to 150°F. The test gas may be dry air or nitrogen. A maximum unit Reynolds of $146 \times 10^6 \text{ ft}^{-1}$ is achieved at a Mach number of 1.0. Independent control of pressure, temperature, fan speed, and inlet guide vane angle permits Mach number, Reynolds number, and dynamic pressure to be varied independently within the wind tunnel operational envelope.

To reduce turbulence, four antiturbulence screens were installed in the settling chamber, and a 15:1 contraction from settling chamber to nozzle throat was provided. To minimize wall interference, the test section floor and ceiling were set at 0°, model support walls at -1.76°, and reentry flaps at 0°. Acoustic treatment upstream and downstream of the fan was incorporated to reduce fan noise. More details of the wind tunnel physical characteristics and operations can be found in reference 14.

Model Description and Test Apparatus

The basic layout of the delta wing model is shown in figure 2(a). The wing has a leading-edge sweep of 65°, no twist or camber, and four sets of interchangeable leading edges, which attach to the flat plate part of the wing. The four leading-edge streamwise contours are illustrated in figure 2(b). The model root chord is 25.734 in., the wing span is 24 in., and the maximum wing thickness is 0.875 in. The wing was fabricated from VascoMax C-200,¹ which is suitable for cryogenic operations, and had a surface finish specification of 8 microinches. Figure 2(c) is a photograph of three of the leading-edge sets; one set is attached to the flat plate part of the model. With the exception of the seam at the plane of symmetry, where the left and right side leading edge sections are joined, each interchangeable leading-edge set (which includes part of the outboard trailing edge) was fabricated as one continuous piece of hardware. This eliminated the surface discontinuity typically associated with an upper and lower leading-edge surface parting line.

The wing and sting surfaces are represented by a fully analytical function with continuity through the second derivative and, hence, curvature. However, the wing-sting intersection line exhibits a discontinuity in slope across it. The leading- and trailing-edge cross-sectional shapes are constant spanwise except for a region near the wingtip where the two shapes intersect. A

¹Trademark of Teledyne Vasco.

detailed geometric description of the various regions of the delta wing and sting (fig. 3) is presented in appendix A. Unless otherwise noted, all quantities have been normalized by the wing root chord.

The model was supported (fig. 4(a)) at the aft end by the model sting, 10°-bent sting, and stub sting. The total model support system confined the center of rotation of the model to the center of the test section. The bent sting extended the positive angle-of-attack range up to approximately 30°.

The model had 183 surface static pressure ports with each having an inside diameter of 0.010 in. The orifice size selection was based on prior cryogenic model-testing experience (ref. 15) at the Langley 0.3-Meter Transonic Cryogenic Tunnel (0.3-m TCT). The majority of the ports were located on the upper surface of the right side (i.e., starboard side) of the model. They were located at nondimensional longitudinal stations of $x/c_R = 0.20, 0.40, 0.60, 0.80,$ and 0.95 . (See fig. 2(a).) At each chord station, the orifices were situated at constant fractions of the local semispan so that they were aligned along rays emanating from the wing apex. The upper surface orifices were located every 5 percent of the local semispan out to one half of the local semispan, beyond which, they were spaced every 2.5 percent of the local semispan. The lower surface pressure ports were located on the left side (i.e., port side) of the model at the same longitudinal stations as on the starboard side. At each chord station, the lower surface orifices were located at local semispan stations of 0.20, 0.40, 0.60, 0.70, 0.80, 0.85, 0.90, and 0.95. In addition, orifices were located directly on both the port and starboard leading edges (except for the sharp leading-edge set) at every 10-percent root chord as well as at the 0.95-chord station. Pressure port location dimensions are shown in tables 1, 2, and 3. Locations that did not have pressure ports are indicated by dashed-line entries.

Instrumentation

Surface static pressure measurements were obtained with four 48-port, 30-psid electronically scanned pressure (ESP) modules. Because of limited volume within the model and its immediate vicinity, the ESP modules were secured inside the enclosure of the wind tunnel pitch system downstream of the stub sting. These modules were placed in a heated container to ensure operation in a cryogenic environment. All model pressure tubes were routed downstream through the sting system and connected to the ESP modules.

Cryogenically rated strain gages configured for two moment bridges were installed on the model sting. These gages were used to monitor model support system safety

during the test. One bridge was located at the wing trailing-edge longitudinal station and the second 4 in. downstream of the wing trailing edge. In figure 4(b), note gage locations at the two rings around the sting just aft of the wing trailing edge. These gages were configured to Poisson ratio full bridges and were shielded from the free stream by a protective chemical coating. Normal force and pitching moment were calculated from measurements of these gages and reported as nondimensional coefficients.

Model angle of attack was determined from the wind tunnel arc-sector angles measured during the test and from sting bending characteristics that were obtained during pretest loadings. The sting fairing cavity volume was insufficient for installation of a fully heated onboard accelerometer package to measure inertial model angles during cryogenic operations.

Measurement Accuracy

The Beattie-Bridgman gas model (ref. 16) and the quoted specifications for the instrumentation were applied to approximate the accuracies of the test parameters and the aerodynamic coefficients. The technique of Kline and McClintock, as specified by Holman (ref. 17), was used to calculate the coefficient accuracies. The uncertainties U of the measurements of the normal-force coefficient C_N , pitching-moment coefficient C_m , pressure coefficient C_p , and free-stream Mach number M_∞ depend on the uncertainties of their respective primary measurements. Estimates of measurement accuracies are presented in appendix B.

The quoted accuracy of an ESP module is ± 0.1 percent of the instrument maximum pressure. Therefore, the accuracy of the 30-psid ESP modules used in this test is ± 0.03 psid.

Data Reduction and Corrections

Data reduction methods used for the pressure data and wind tunnel parameters were those outlined in reference 16. To obtain force and moment data, the strain gages on the sting were treated as two-component strain gage balances in the data reduction procedure. (See ref. 18.) Because the Reynolds number range was achieved at only two test temperatures for the various total pressures, aeroelastic effects (i.e., model deformation due to pressure) can distort the true Reynolds number effects. However, the aeroelastic effect on the aerodynamic data is small because of the relatively high stiffness resulting from the model thickness and low-aspect-ratio planform as well as the support system structure as illustrated in figure 4(a). Measurements for

an inverted model attitude were not taken, and a nominal flow angularity correction of $+0.13^\circ$ (upflow) was applied to the reported angles of attack.

Test Program

Figure 5 shows the combinations of Reynolds numbers and free-stream Mach numbers used for the test. The test matrix shows that a Mach number of 0.85 was selected for the study of the Reynolds number effects and that Reynolds numbers of 6×10^6 , 60×10^6 , and 120×10^6 were selected for the study of Mach number effects. Note that a coarse Reynolds number study can be made for Mach numbers of 0.40 and 0.60. All data were obtained with free boundary layer transition.

Data Presentation

Pressure data measured on the delta wing are presented for each data point in tabular and graphical formats in appendixes C–H. Normal-force and pitching-moment data for each angle of attack are presented in figures 6–9. The moment reference point was located at two thirds of the root chord aft of the wing apex. The angle of attack ranged nominally from -1° to 27° .

Wing pressure coefficients are tabulated for each data point and accompanied by a surface pressure distribution plot and a leading-edge pressure plot. The degree of similarity between the port and starboard leading-edge pressure plots indicates the extent of flow symmetry. Note that a coefficient value represented by a series of asterisks in tables C1–C3, D1–D3, E1–E11, F1–F4,

G1–G4, and H1–H4 is either an unrecorded or an apparently erroneous pressure port measurement.

The pressure coefficient data test matrix is presented in table 4. Data across Reynolds number ranges at Mach numbers of 0.40, 0.60, and 0.85 are given in appendixes C, D, and E, respectively, and data across Mach number ranges for Reynolds numbers of 6×10^6 , 60×10^6 , and 120×10^6 are given in appendixes F, G, and H, respectively.

Summary Remarks

Pressure data obtained from a 65° delta wing with the medium-radius leading edge (i.e., 0.15 percent of mac) are presented in the form of surface pressure plots and leading-edge pressure plots for a Reynolds number range of 6×10^6 to 120×10^6 at a Mach number of 0.85 and a Mach number range of 0.40 to 0.90 at Reynolds numbers of 6×10^6 , 60×10^6 , and 120×10^6 . Although upper and lower surface pressures were measured on opposite sides of the model, model symmetry permitted pressure distribution plots to be superimposed on a sketch of the half wing. The plots of the leading-edge pressures indicate the extent of flow symmetry by comparing port and starboard leading-edge pressures. Normal-force and pitching-moment coefficient plots for Reynolds number and Mach number ranges are also presented.

NASA Langley Research Center
Hampton, VA 23681-0001
August 11, 1995

Table 1. Wing Upper Surface Pressure Port Locations on Starboard Side

η	x/c_R of—									
	0.20		0.40		0.60		0.80		0.95	
	x, in.	y, in.	x, in.	y, in.	x, in.	y, in.	x, in.	y, in.	x, in.	y, in.
0.050	5.147	0.120	10.294	0.240	15.440	0.360	-----	-----	-----	-----
.100	↓	.240	↓	.480	↓	.720	-----	-----	-----	-----
.150	↓	.360	↓	.720	↓	1.080	-----	-----	-----	-----
.200	↓	.480	↓	.960	↓	1.440	-----	-----	24.447	2.280
.250	-----	-----	↓	1.200	↓	1.800	20.587	2.400	↓	2.850
.300	5.147	.720	↓	1.440	↓	2.160	↓	2.880	↓	3.420
.350	↓	.840	↓	1.680	↓	2.520	↓	3.360	↓	3.990
.400	↓	.960	↓	1.920	↓	2.880	↓	3.840	↓	4.560
.450	↓	1.080	↓	2.160	↓	3.240	↓	4.320	↓	5.130
.500	↓	1.200	↓	2.400	↓	3.600	↓	4.800	↓	5.700
.525	-----	-----	↓	2.520	↓	3.780	↓	5.040	↓	5.985
.550	5.147	1.320	↓	2.640	↓	3.960	↓	5.280	↓	6.270
.575	-----	-----	↓	2.760	↓	4.140	↓	5.520	↓	6.550
.600	5.147	1.440	↓	2.880	↓	4.320	↓	5.760	↓	6.840
.625	-----	-----	-----	-----	↓	4.500	↓	6.000	↓	7.125
.650	5.147	1.560	10.294	3.120	↓	4.680	↓	6.240	↓	7.410
.675	-----	-----	↓	3.240	↓	4.860	↓	6.480	↓	7.695
.700	5.147	1.680	↓	3.360	↓	5.040	↓	6.720	↓	7.980
.725	-----	-----	↓	3.480	↓	5.220	↓	6.960	↓	8.265
.750	5.147	1.800	↓	3.600	-----	-----	↓	7.200	↓	8.550
.775	-----	-----	↓	3.720	15.440	5.580	↓	7.440	↓	8.835
.800	5.147	1.920	↓	3.840	↓	5.760	↓	7.680	↓	9.120
.825	-----	-----	↓	3.960	↓	5.940	↓	7.920	↓	9.405
.850	5.147	2.040	↓	4.080	↓	6.120	↓	8.160	↓	9.690
.875	-----	-----	↓	4.200	↓	6.300	↓	8.400	↓	9.975
.900	5.147	2.160	↓	4.320	↓	6.480	↓	8.640	↓	10.260
.925	-----	-----	↓	4.440	↓	6.660	↓	8.880	↓	10.545
.950	5.147	2.280	↓	4.560	↓	6.840	↓	9.120	↓	10.830
.975	-----	-----	↓	4.680	↓	7.020	↓	9.360	↓	11.115
1.000	5.147	2.400	↓	4.800	↓	7.200	↓	9.600	↓	11.400

Table 2. Wing Lower Surface Pressure Port Locations on Port Side

η	x/c_R of—									
	0.20		0.40		0.60		0.80		0.95	
	x, in.	y, in.	x, in.	y, in.	x, in.	y, in.	x, in.	y, in.	x, in.	y, in.
-0.200	5.147	-0.480	10.294	-0.960	15.440	-1.440	-----	-----	24.447	-2.280
-.400	↓	-.960	↓	-1.920	↓	-2.880	20.587	-3.840	↓	-4.560
-.600		-1.440	↓	-2.880	↓	-4.320	↓	-5.760	↓	-6.840
-.700		-1.680	↓	-3.360	↓	-5.040	↓	-6.720	↓	-7.980
-.800		-1.920	↓	-3.840	↓	-5.760	↓	-7.680	↓	-9.120
-.850		-2.040	↓	-4.080	↓	-6.120	↓	-8.160	↓	-9.690
-.900		-2.160	↓	-4.320	↓	-6.480	↓	-8.640	↓	-10.260
-.950	↓	-2.280	↓	-4.560	↓	-6.840	↓	-9.120	↓	-10.830
-.975	-----	-----	↓	-4.680	↓	-7.020	↓	-9.360	↓	-11.115
-1.000	5.147	-2.400	↓	-4.800	↓	-7.200	↓	-9.600	↓	-11.400

Table 3. Wing Leading-Edge Pressure Port Locations on Starboard Side

η	x/c_R of—									
	0.10		0.30		0.50		0.70		0.90	
	x, in.	y, in.	x, in.	y, in.	x, in.	y, in.	x, in.	y, in.	x, in.	y, in.
1.000	2.573	1.200	7.720	3.600	12.867	6.000	18.014	8.400	23.161	10.800

Table 4. Pressure Coefficient Data for Medium-Radius Leading Edge

Appendix table	Run	Mach	R_{mac}	q_{∞} , psf	t_p , °F
C1	3	0.40	6×10^6	387	120
C2	21	↓	60	950	-250
C3	29	↓	73	1150	-250
D1	4	0.60	6	555	120
D2	23	↓	60	1344	-250
D3	30	↓	101	2265	-250
E1	7	0.85	6	722	120
E2	10	↓	12	1444	120
E3	11	↓	24	690	-250
E4	12	↓	36	1035	↓
E5	13	↓	48	1380	↓
E6	14	↓	60	1725	↓
E7	19	↓	72	2068	↓
E8	20	↓	84	2413	↓
E9	15	↓	96	2756	↓
E10	16	↓	108	3099	↓
E11	17	↓	120	3442	↓
F1	5	0.80	6	692	120
F2	6	.83	↓	710	↓
F3	8	.87	↓	733	↓
F4	9	.90	↓	750	↓
G1	24	.80	60	1659	-250
G2	25	.83	↓	1699	↓
G3	27	.87	↓	1749	↓
G4	28	.90	↓	1785	↓
H1	31	.80	120	3312	↓
H2	34	.83	↓	3391	↓
H3	33	.87	↓	3491	↓
H4	32	.90	↓	3561	↓

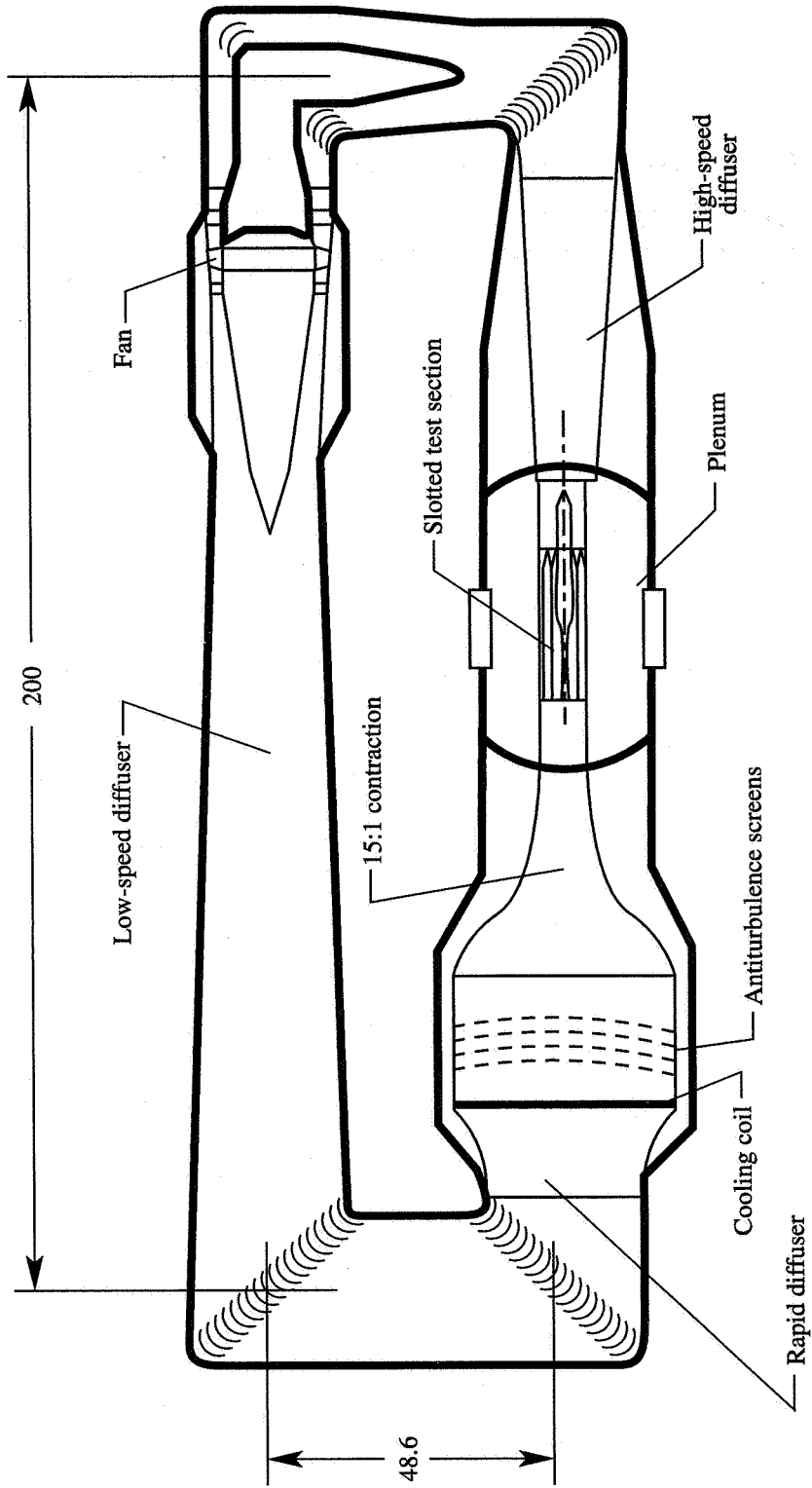
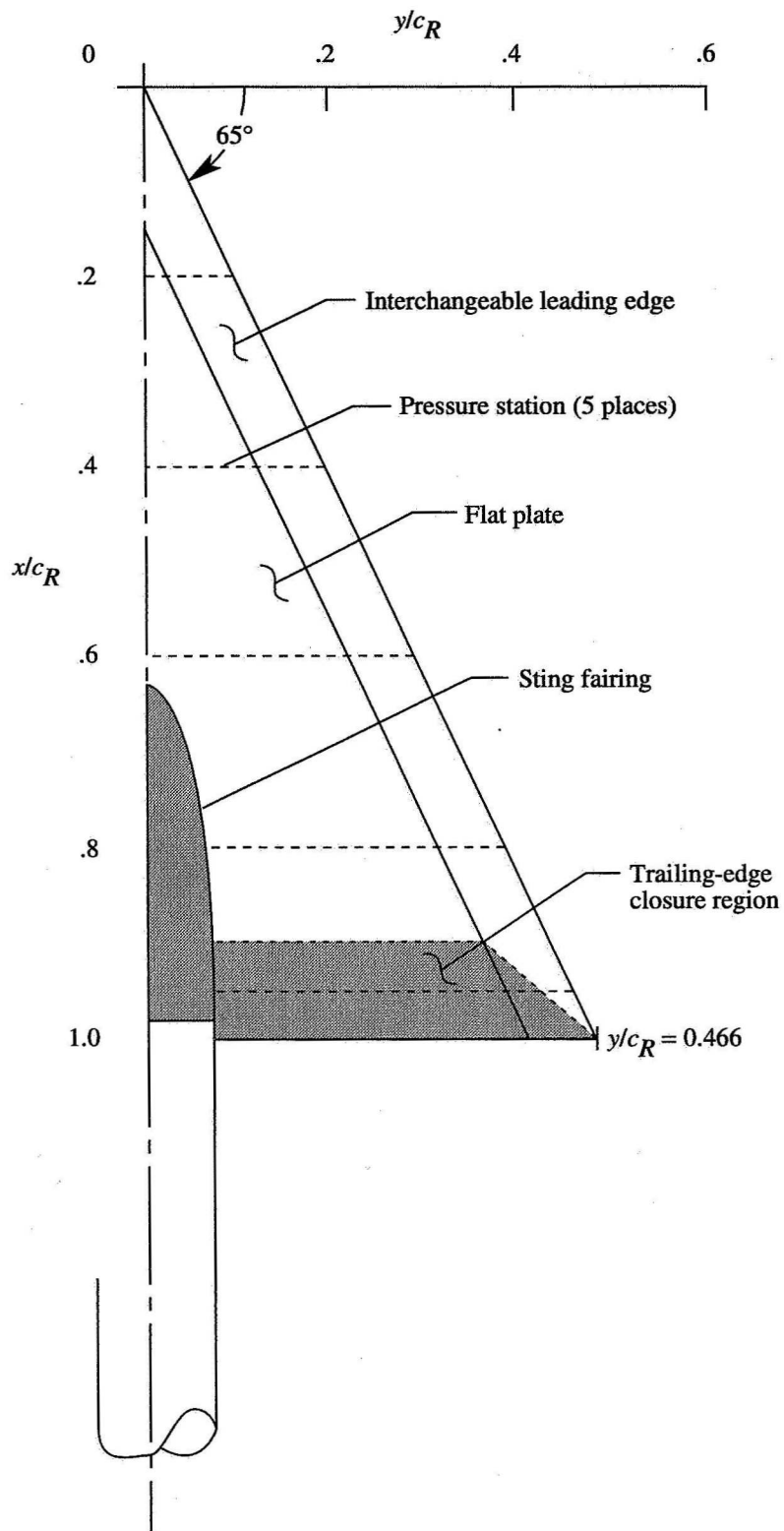
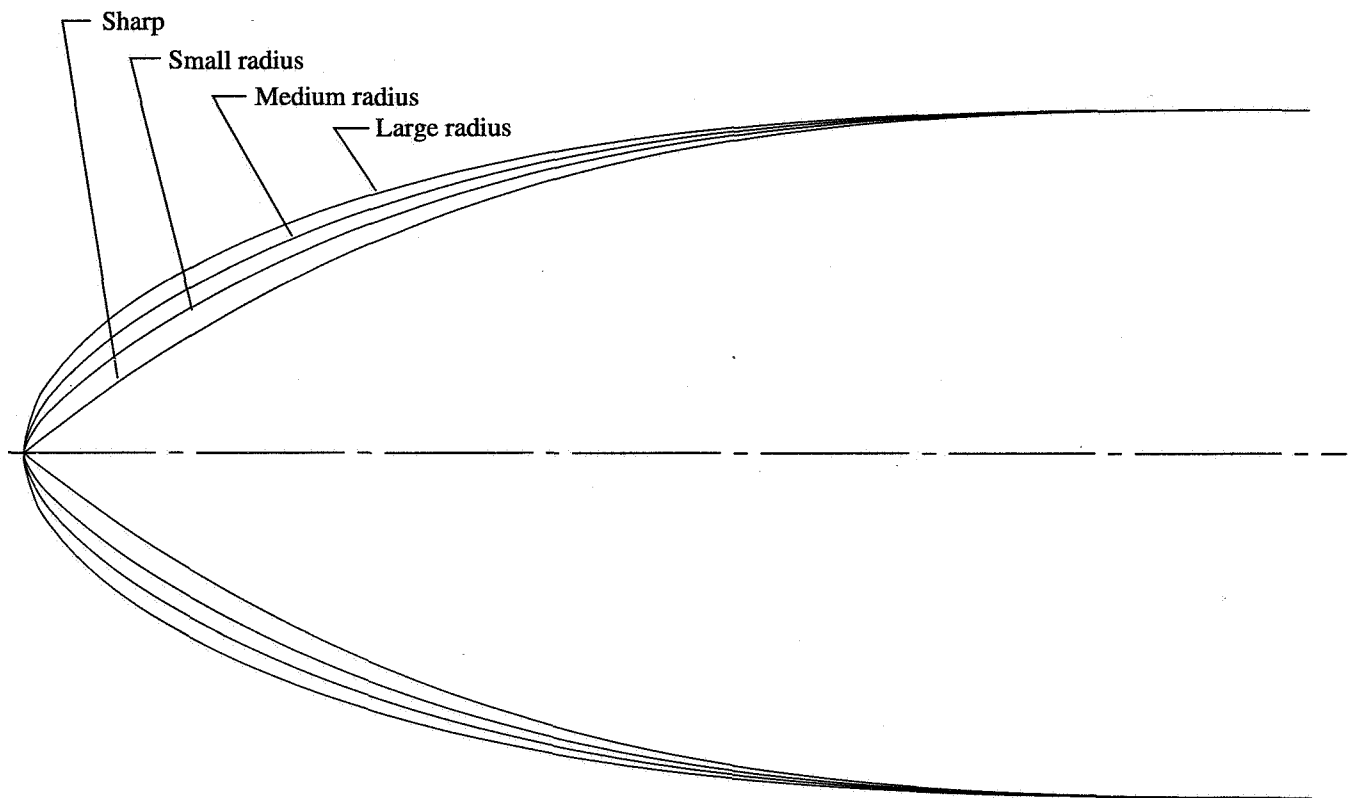

Figure 1. Langley National Transonic Facility circuit. Linear dimensions are in feet.



(a) Model configuration.

Figure 2. Delta wing model.



(b) Streamwise leading-edge contours (not to scale).

Figure 2. Continued.

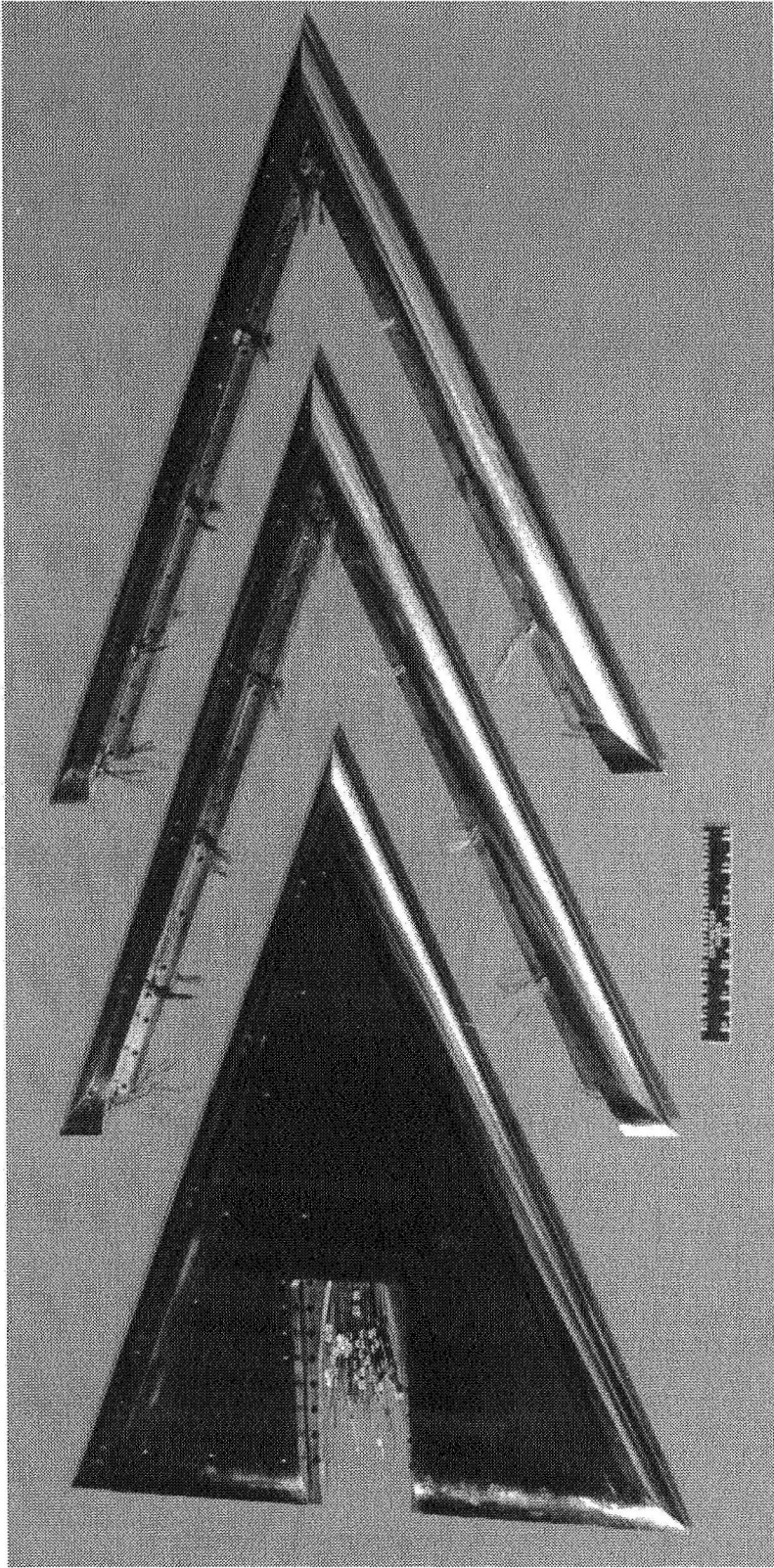

(c) Model with three leading-edge sets.

Figure 2. Concluded.

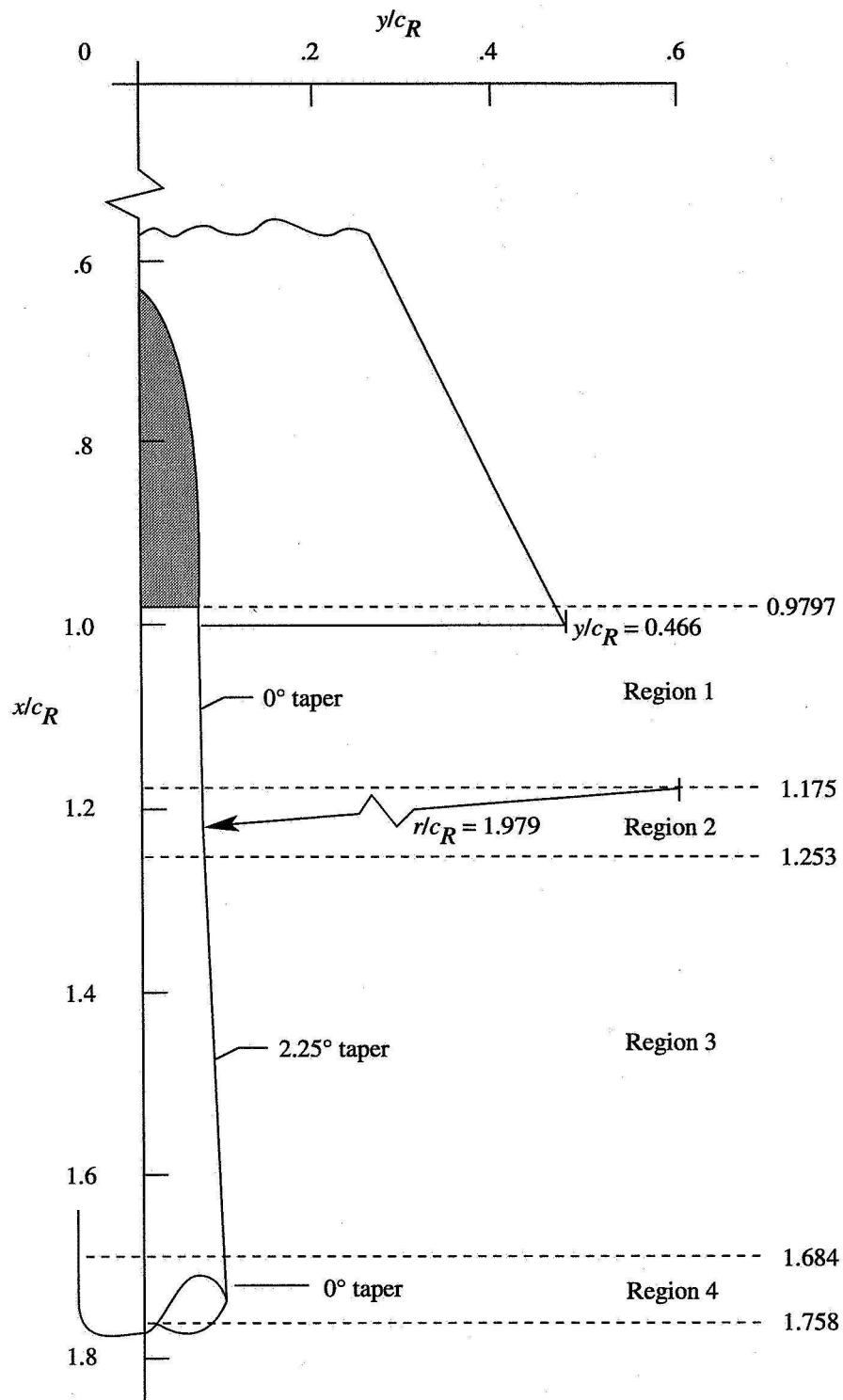
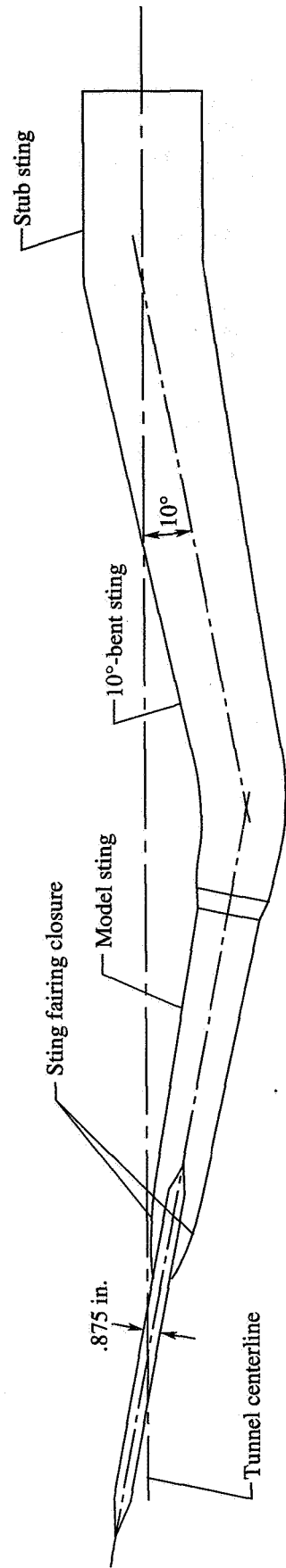

Figure 3. Delta wing model fore-sting detail.



(a) Model and sting system profile.

Figure 4. The 65° delta wing model assembly and support system.



L-91-6963

(b) Installation in Langley National Transonic Facility.

Figure 4. Concluded.

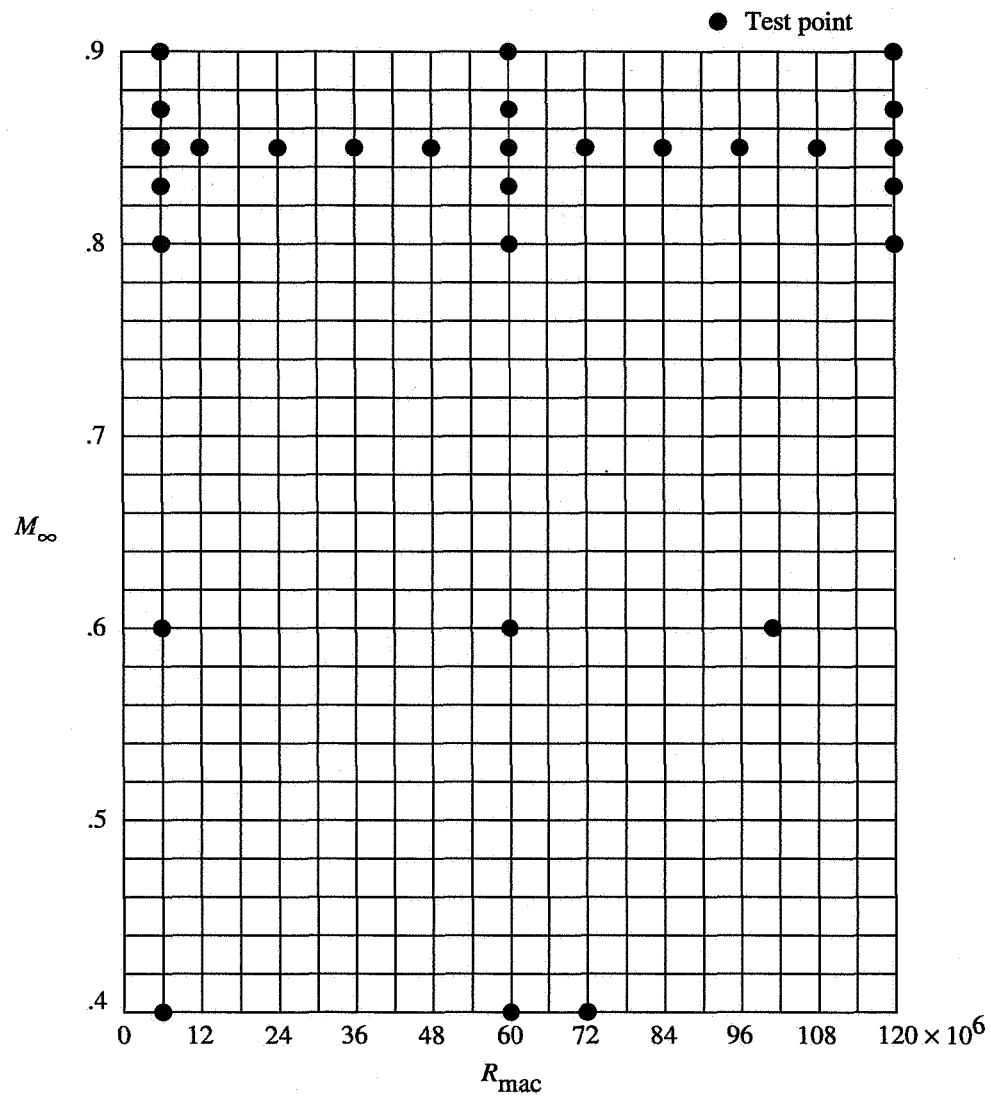
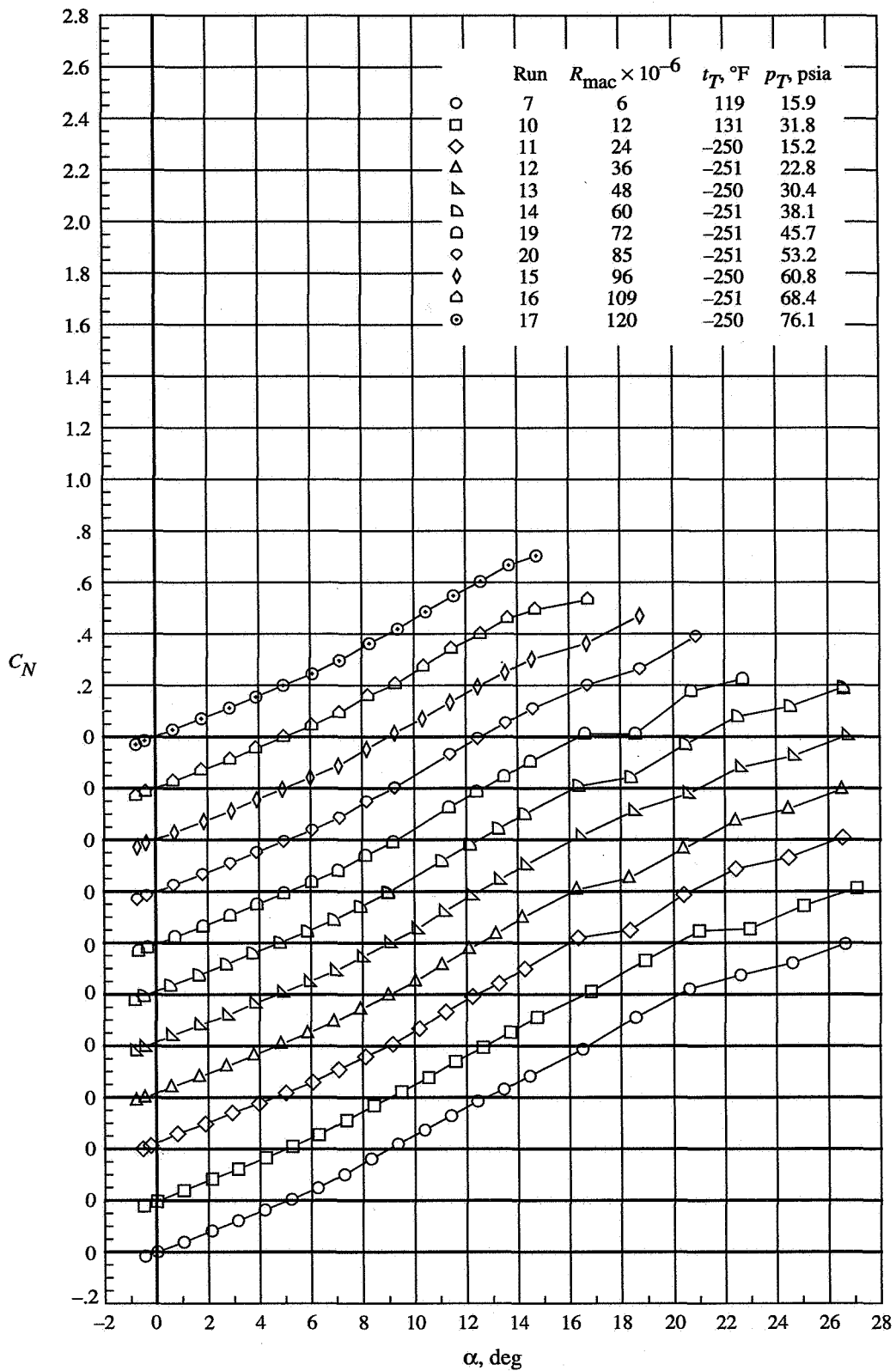
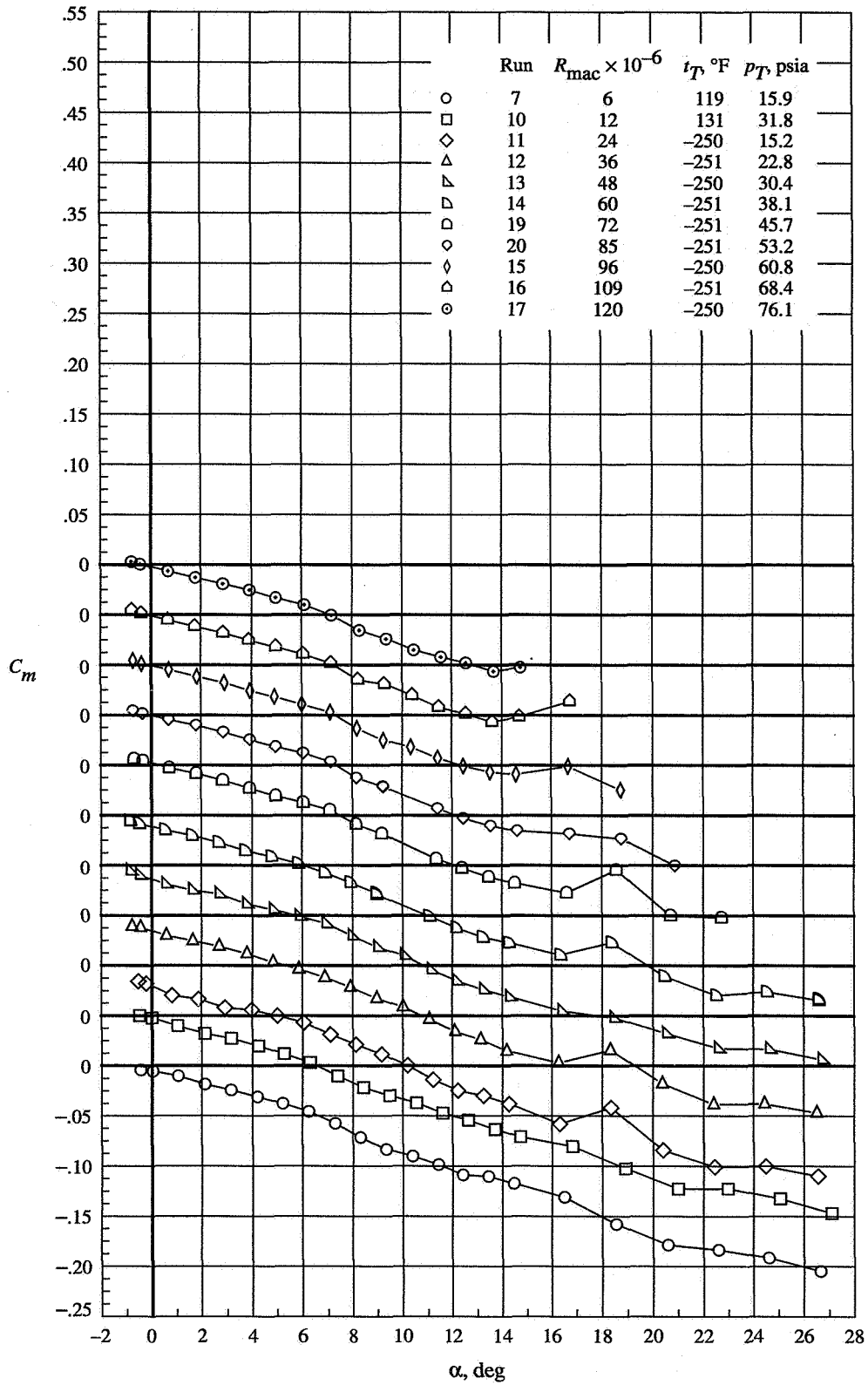

Figure 5. Test matrix for 65° delta wing with medium-radius leading edge.



(a) C_N versus α .

Figure 6. Normal-force and pitching-moment coefficients for angles of attack for wing with medium-radius leading edge. $M_\infty \approx 0.85$.



(b) C_m versus α .

Figure 6. Concluded.

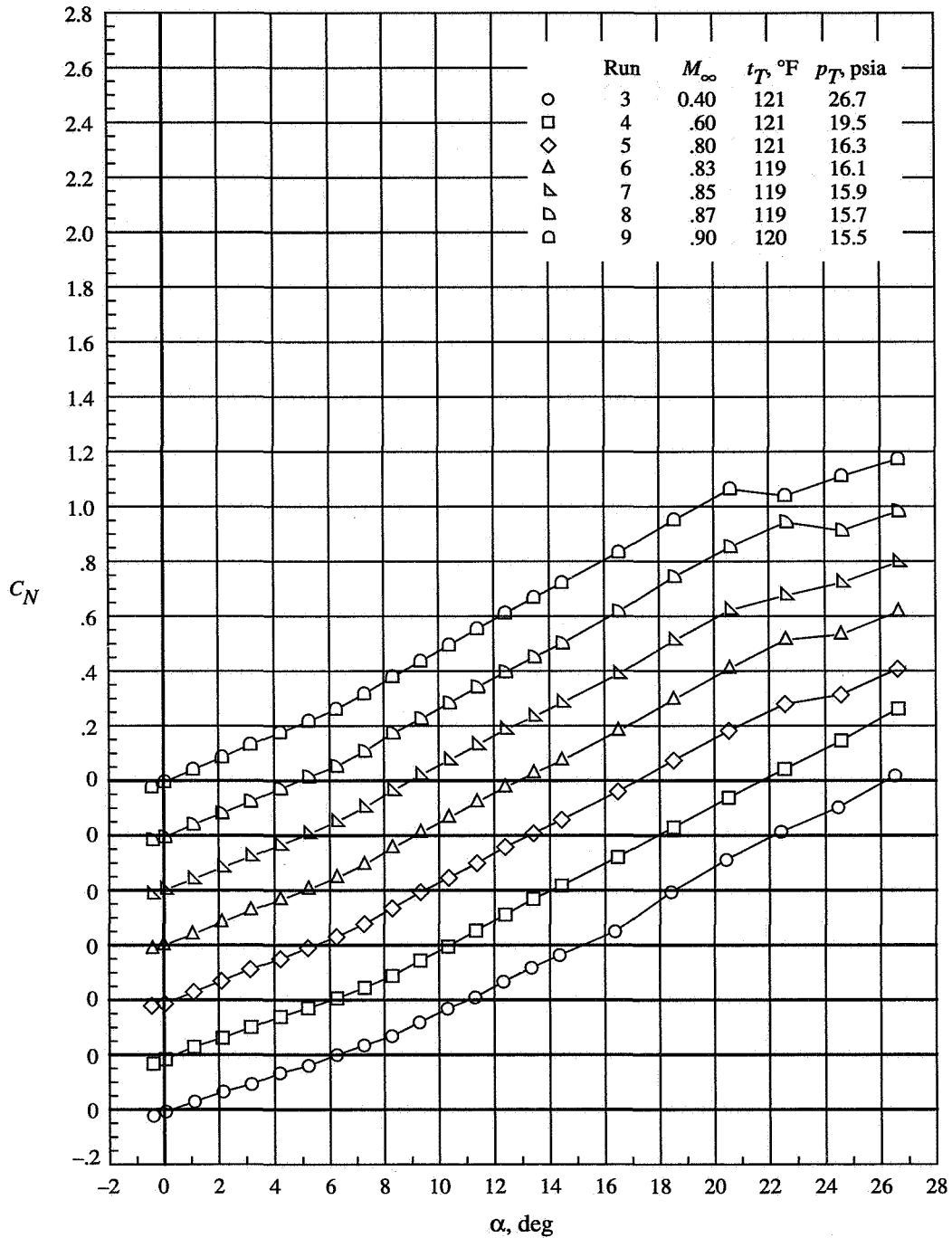

(a) C_N versus α .

Figure 7. Normal-force and pitching-moment coefficients for angles of attack for wing with medium-radius leading edge. $R_{mac} \approx 6 \times 10^6$.

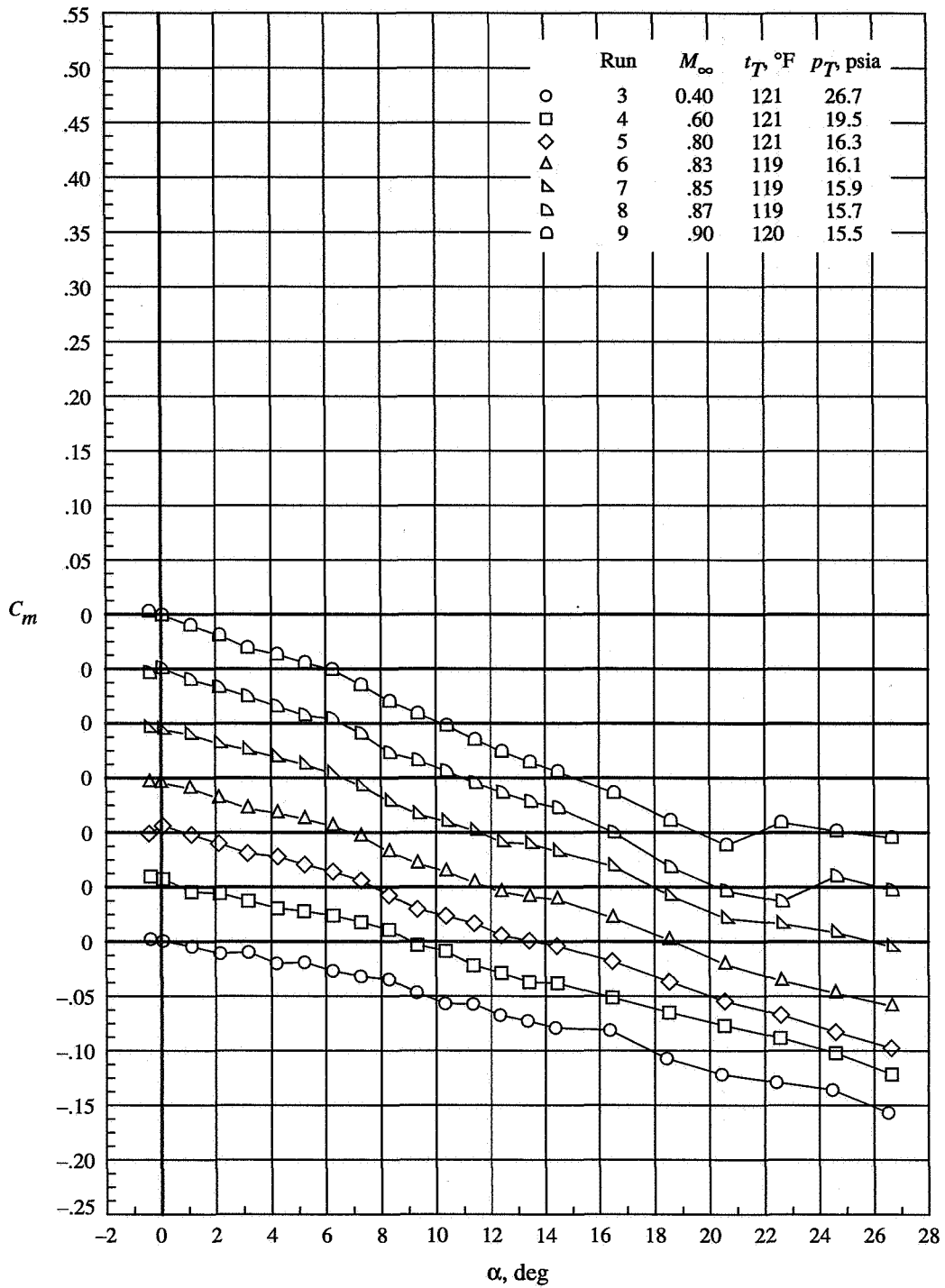

(b) C_m versus α .

Figure 7. Concluded.

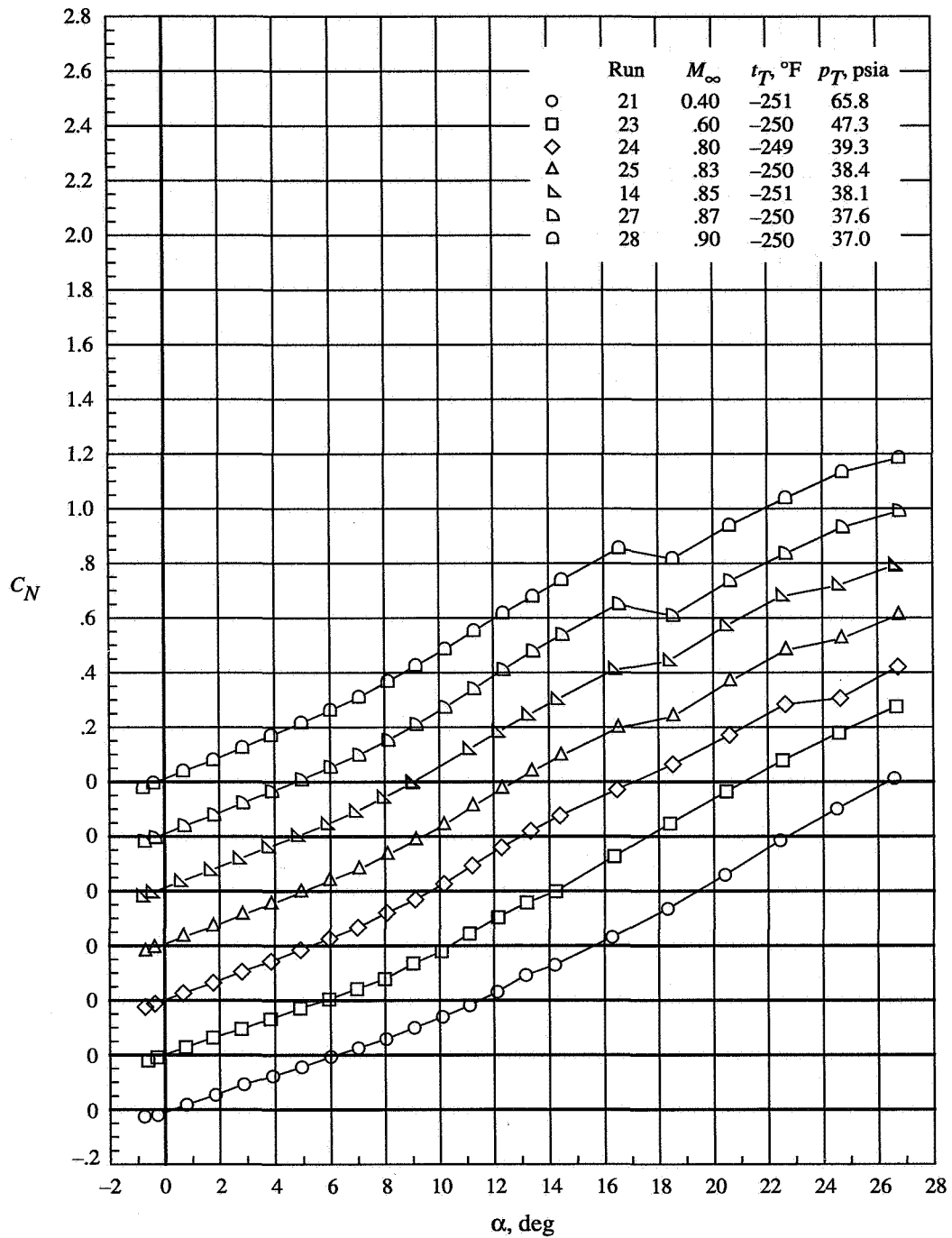

(a) C_N versus α .

Figure 8. Normal-force and pitching-moment coefficients at angles of attack for wing with medium-radius leading edge.
 $R_{\text{mac}} \approx 60 \times 10^6$.

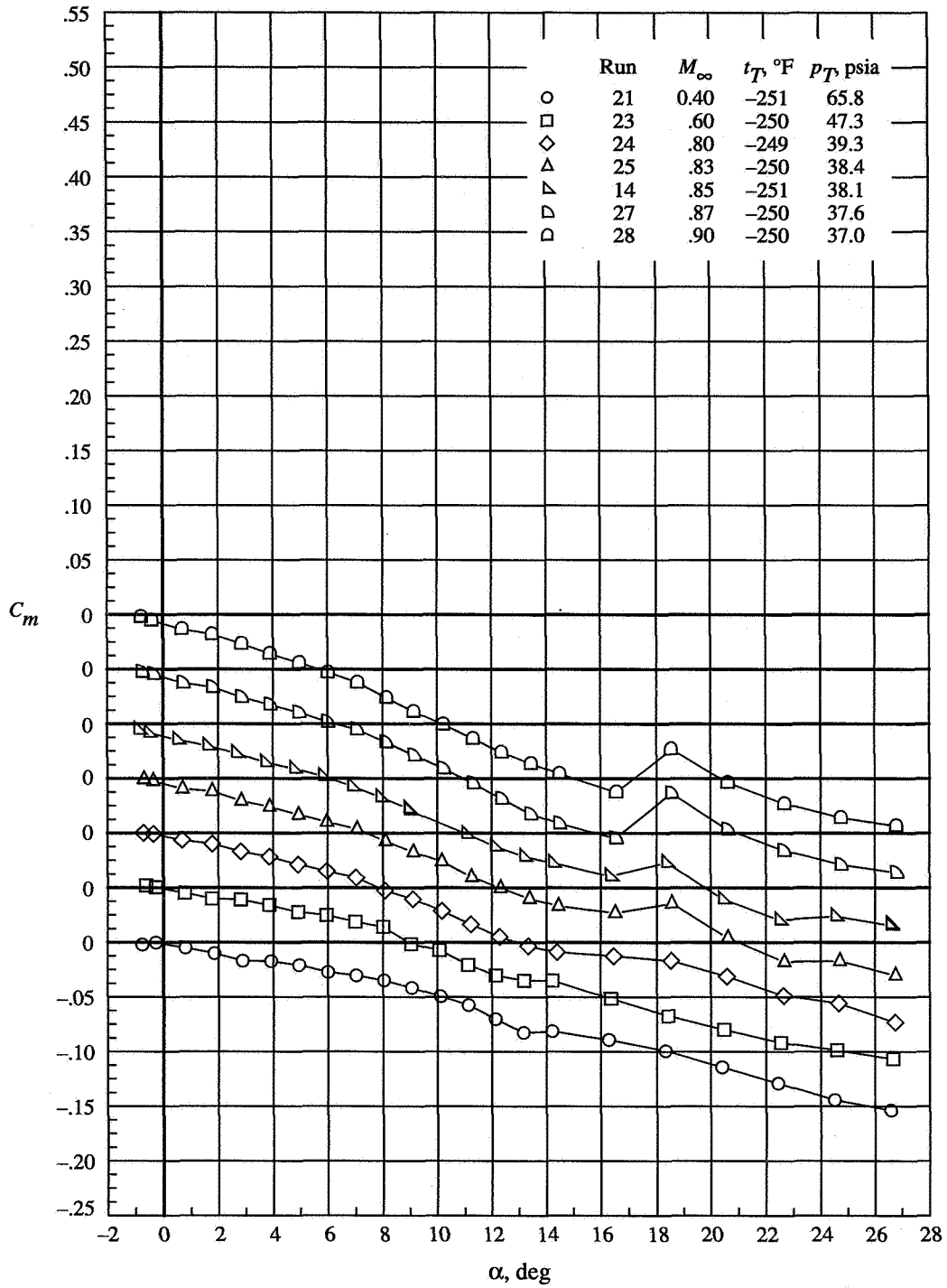

(b) C_m versus α .

Figure 8. Concluded.

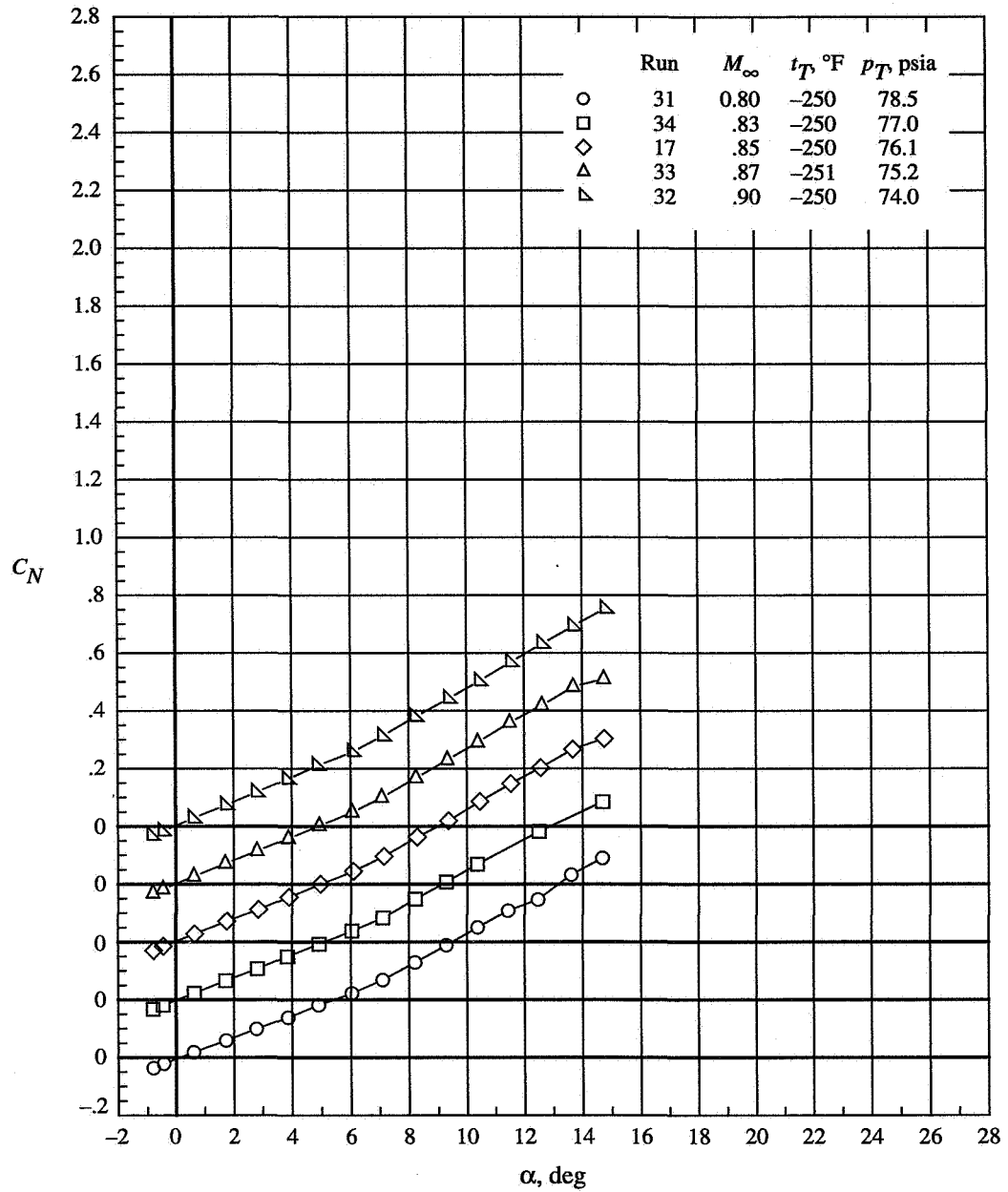

(a) C_N versus α .

Figure 9. Normal-force and pitching-moment coefficients at angles of attack for wing with medium-radius leading edge.
 $R_{mac} \approx 120 \times 10^6$.

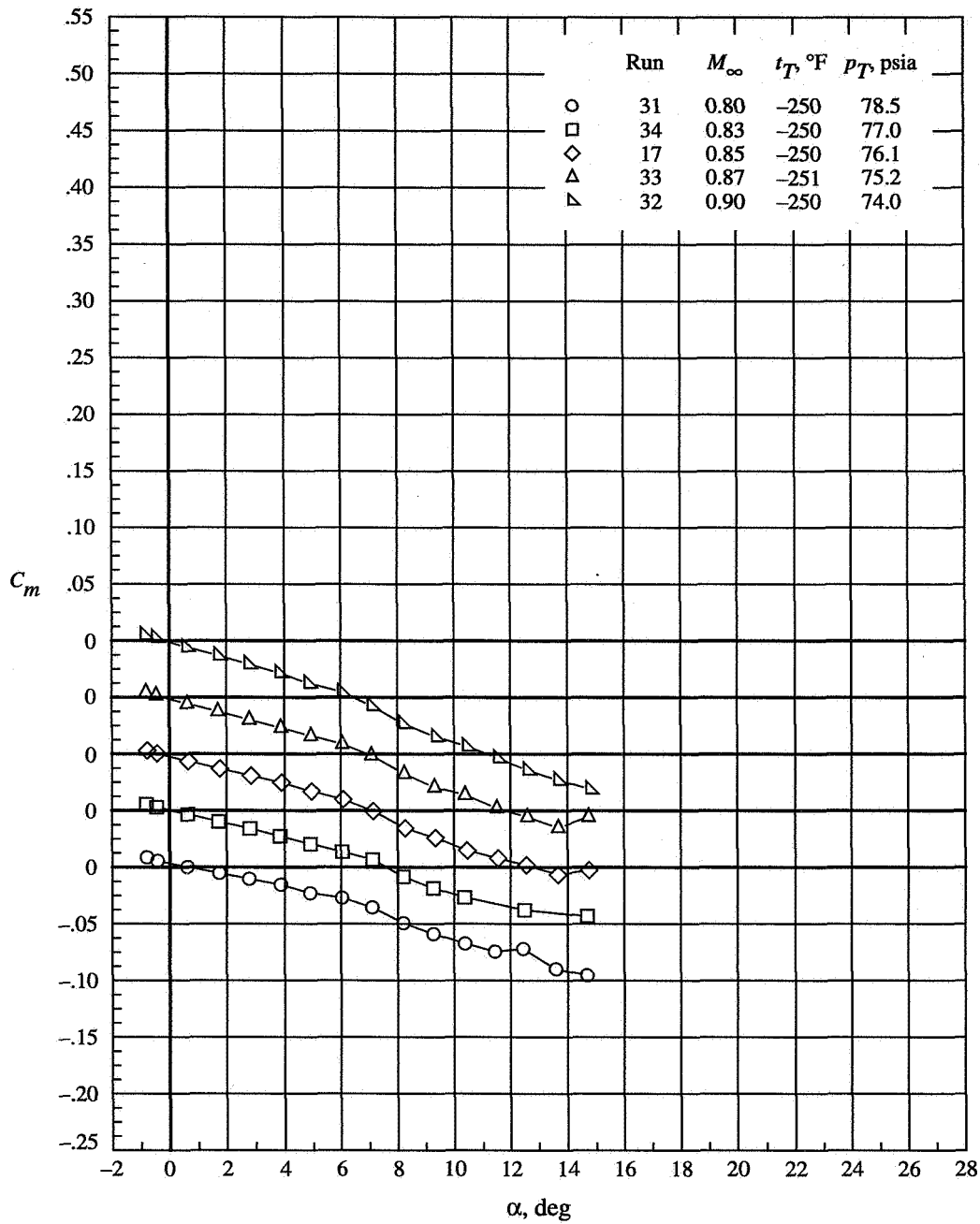

(b) C_m versus α .

Figure 9. Concluded.

Appendix A

Delta Wing and Near-Field Sting Analytical Definition

General equations were used to define the leading-edge semithickness, the flat plate semithickness, the trailing-edge closure semithickness, and the transverse radius of the sting fairing. The equation ϕ defines the particular shape of interest (e.g., the leading-edge contour) and the equation ψ defines the boundary conditions (at $\xi = 1$) for ϕ . Details are as follows:

$$\xi = (x - x_0)/x_1 \quad (\text{A1})$$

$$\phi(\xi) = \pm x_1 \left(a\sqrt{\xi} + b\xi + c\xi^2 + d\xi^3 \right) \quad (0 \leq \xi \leq 1) \quad (\text{A2})$$

$$\psi(\xi) = \pm x_1 \left[\frac{l}{x_1} + m(\xi - 1) + \frac{nx_1}{2}(\xi - 1)^2 \right] \quad (1 \leq \xi) \quad (\text{A3})$$

The second-blending function ψ is defined such that

$$\psi|_{\xi=1} = l \quad \frac{d\psi}{dx}|_{\xi=1} = m \quad \frac{d^2\psi}{dx^2}|_{\xi=1} = n$$

The two functions ϕ and ψ are illustrated in figure A1 for the leading-edge semithickness case where $x_0 = x_{le}$.

The general analytical expressions for the coefficients in equation (A2) follow:

$$\begin{aligned} a &= \sqrt{\frac{2r}{x_1}} \\ b &= -\frac{15}{8}a + 3\frac{l}{x_1} - 2m + \frac{nx_1}{2} \\ c &= \frac{5}{4}a - 3\frac{l}{x_1} + 3m - nx_1 \\ d &= -\frac{3}{8}a + \frac{l}{x_1} - m + \frac{nx_1}{2} \end{aligned}$$

With these expressions

$$\phi(1) = \psi(1) \quad \phi'(1) = \psi'(1) \quad \phi''(1) = \psi''(1)$$

and the leading-edge radius at $\xi = 0$ is r . Curvature is also continuous at $\xi = 1$.

For the delta wing model of this study, the flat plate part represented by ψ results in both m and n being zero. The reduced coefficients are

$$\begin{aligned} a &= \sqrt{\frac{2r}{x_1}} \\ b &= -\frac{15}{8}a + 3\frac{l}{x_1} \\ c &= \frac{5}{4}a - 3\frac{l}{x_1} \\ d &= -\frac{3}{8}a + \frac{l}{x_1} \end{aligned}$$

For a sharp leading edge, the radius $r = 0$ and the coefficients further reduce to

$$\begin{aligned} a &= 0 \\ b &= 3\frac{l}{x_1} \\ c &= -3\frac{l}{x_1} \\ d &= \frac{l}{x_1} \end{aligned}$$

Specific numerical values follow for the delta wing in subsequent discussions.

Leading Edges

The streamwise leading-edge contours are designed to give leading-edge radii of 0, 0.05, 0.15, and 0.30 percent of the mean aerodynamic chord and to match the flat plate wing at a streamwise distance of 15 percent of the root chord aft of the leading edge with continuity through the second derivative. The longitudinal coordinate of the leading edge is x_{le} and the leading-edge contour is described by equation (A2), the coefficients in table A1, and the following definitions:

$$\begin{aligned} x_0 &= x_{le} \\ x_1 &= 0.15 \end{aligned}$$

Flat Plate

The flat plate center part of the wing has a uniform thickness. The equation for the semithickness is as follows:

$$\begin{aligned} x_0 &= x_{le} + 0.15 \\ x_1 &= 0.9 - x_0 \end{aligned}$$

$$\phi(\xi) = \pm 0.0170008 \quad (0 \leq \xi \leq 1)$$

Trailing-Edge Closure Region

The streamwise trailing-edge closure is designed to produce a sharp trailing edge and to match the flat plate wing at the 90-percent root chord station with continuity through the second derivative. The closure is described by equation (A2), the coefficients in table A2, and the following definitions:

$$x_0 = 1$$

$$x_1 = 0.10$$

Sting Fairing

The sting is a body of revolution and the sting fairing is designed to emerge from the wing slightly aft of the 60-percent root chord station and to match the constant-radius part of the sting slightly ahead of the wing trailing edge. The transverse radius of the sting fairing is

described by equation (A2), the coefficients in table A3, and the following definitions:

$$x_0 = 0.61057051$$

$$x_1 = 0.36916023$$

Fore-Sting

As shown in figure 3, the downstream continuation of the sting in the near field of the wing is referred to as the fore-sting. It can be subdivided into the four regions listed in table A4 for the purpose of defining the sting transverse radius ϕ . In region 2, the sting transverse radius increases by the radius of curvature equal to 1.979 from $x/c_R = 1.175$. (See fig. 3.) Beyond region 4, the actual sting geometry becomes more complex. For computational purposes, the sting could be either extended as is or closed out in a convenient fashion.

Table A1. Leading-Edge Coefficients for Equation (A2)

r/\bar{c} , percent	a	b	c	d
0	0	$3d$	$-b$	0.1133386669
.05	0.06666666666667	0.21501600073802	-0.25668266740469	.08833866691267
.15	.11547005383792	.12350964979191	-.19567843344062	.07003739672345
.30	.16329931618554	.03382978289013	-.13589185550609	.05210142334309

Table A2. Trailing-Edge Coefficients for Equation (A2)

r/\bar{c} , percent	a	b	c	d
0	0	$3d$	$-b$	0.17000800036901

Table A3. Sting Fairing Coefficients for Equation (A2)

r/\bar{c} , percent	a	b	c	d
0.27910261994295	0.10040234847327	0.33279822819157	-0.39554969598736	0.13603332984884

Table A4. Fore-Sting Transverse Radius ϕ

Region	Taper, deg	x/c_R	ϕ
1	0	From 0.9797	0.06412
		To 1.175	0.06412
2		From 1.175	0.06412
		To 1.253	0.06564
3	2.25	From 1.253	0.06564
		To 1.684	0.08258
4	0	From 1.684	0.08258
		To 1.758	0.08258

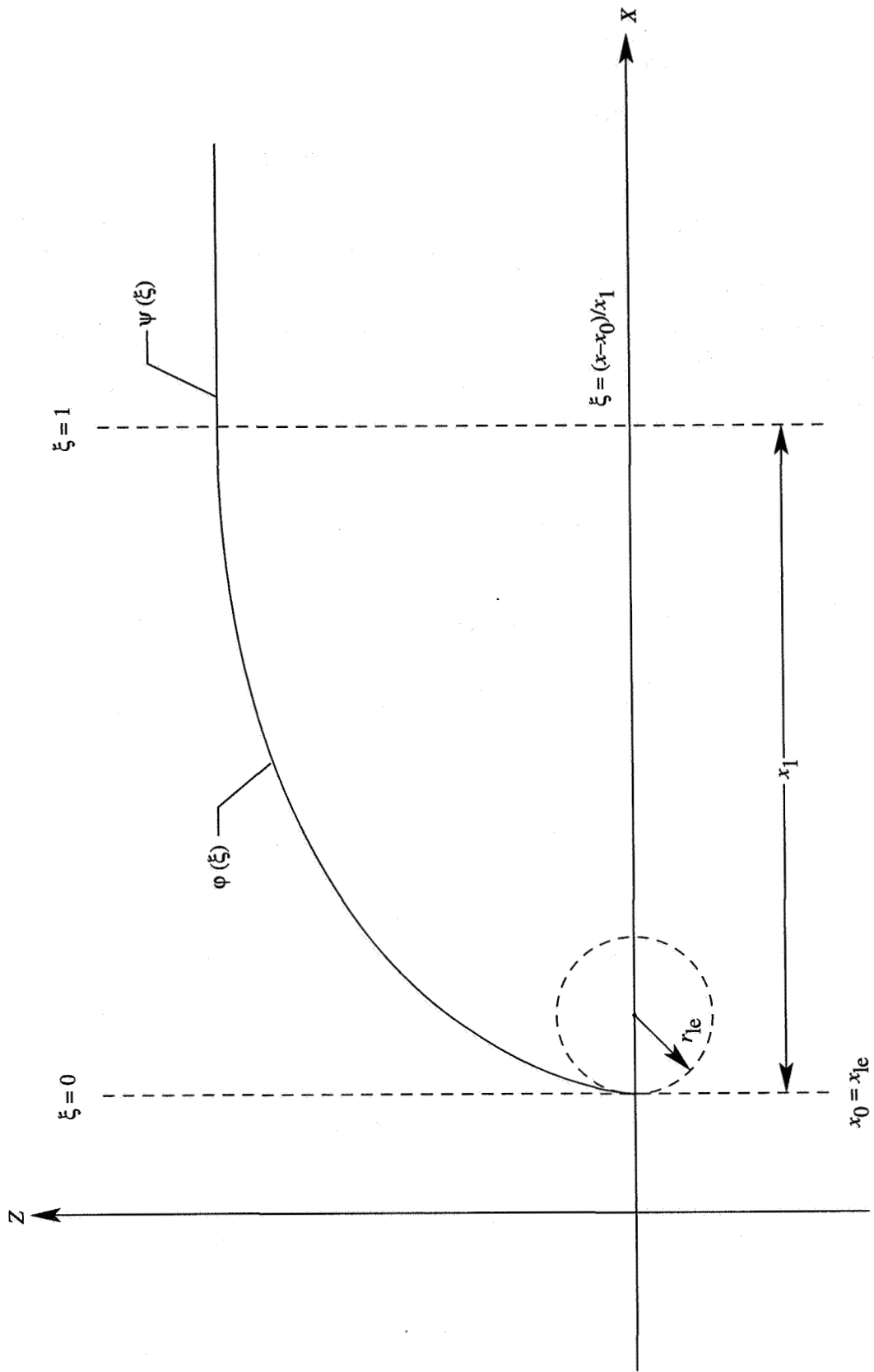

Figure A1. Delta wing semithickness functions.

Appendix B

Data Uncertainty

The uncertainties U of the measurements of the normal-force coefficient C_N , pitching-moment coefficient C_m , pressure coefficient C_p , and free-stream Mach number M_∞ depend on the uncertainties of their respective primary measurements.

The coefficients C_N , C_m , and C_p (Mach number is discussed separately) are derived by

$$C_N = \frac{F_N}{q_\infty S} \quad (B1)$$

$$C_m = \frac{M_Y}{q_\infty S \bar{c}} \quad (B2)$$

$$C_p = \frac{p - p_\infty}{q_\infty} \quad (B3)$$

The primary measurements used to define these coefficients are the normal force F_N , pitching moment M_Y , surface local static pressure p , free-stream static pressure p_∞ , and free-stream total pressure p_T . The free-stream static pressure and the free-stream total pressure are used to compute the free-stream Mach number, which, in turn, is used to compute the free-stream dynamic pressure q_∞ .

The free-stream dynamic pressure that accounts for the compressibility effect in high-speed flow is defined as

$$q_\infty = \frac{1}{2} \gamma p_\infty M_\infty^2 \quad (B4)$$

where γ denotes the ratio of specific heats. Substitutions for the dynamic pressure in the normal-force, pitching-moment, and pressure coefficient equations (B1), (B2), and (B3), respectively, give

$$C_N = \frac{F_N}{\frac{1}{2} \gamma p_\infty M_\infty^2 S} \quad (B5)$$

$$C_m = \frac{M_Y}{\frac{1}{2} \gamma p_\infty M_\infty^2 S \bar{c}} \quad (B6)$$

$$C_p = \frac{p - p_\infty}{\frac{1}{2} \gamma p_\infty M_\infty^2} \quad (B7)$$

The Mach number, which is not a primary measurement, is derived from the free-stream static and total pressures and the ratio of specific heats. Thus,

$$M_\infty = \left\{ \frac{2}{\gamma - 1} \left[\left(\frac{p_\infty}{p_T} \right)^{-(\gamma - 1)/\gamma} - 1 \right] \right\}^{1/2} \quad (B8)$$

The coefficients are then functions of the following measured variables: the normal force, the pitching moment, the local pressure, the free-stream static pressure, and the free-stream Mach number; the Mach number is a function of the free-stream static pressure and the free-stream total pressure (i.e., stagnation pressure). The uncertainties $U(\cdot)$ of these primary measured variables are presented in table B1.

Table B1. Data Uncertainties

Variable	Uncertainty
$U(F_N)$, lbf	<24.0
$U(M_Y)$, in-lbf	<46.8
$U(p)$, lbf/in ²	<0.03
$U(p_T)$, lbf/in ²	<0.01
$U(p_\infty)$, lbf/in ²	<0.02

The probability of the value of each uncertainty being correct is assumed to be the same. From reference 17, the uncertainty for each of the coefficients of equations (B5)–(B8) with the same probability is

$$U(C_N) = \left\{ \left[\frac{\partial C_N}{\partial F_N} U(F_N) \right]^2 + \left[\frac{\partial C_N}{\partial p_\infty} U(p_\infty) \right]^2 + \left[\frac{\partial C_N}{\partial M_\infty} U(M_\infty) \right]^2 \right\}^{1/2} \quad (B9)$$

$$U(C_m) = \left\{ \left[\frac{\partial C_m}{\partial M_Y} U(M_Y) \right]^2 + \left[\frac{\partial C_m}{\partial p_\infty} U(p_\infty) \right]^2 + \left[\frac{\partial C_m}{\partial M_\infty} U(M_\infty) \right]^2 \right\}^{1/2} \quad (B10)$$

$$U(C_p) = \left\{ \left[\frac{\partial C_p}{\partial p} U(p) \right]^2 + \left[\frac{\partial C_p}{\partial p_\infty} U(p_\infty) \right]^2 + \left[\frac{\partial C_p}{\partial M_\infty} U(M_\infty) \right]^2 \right\}^{1/2} \quad (B11)$$

$$U(M_\infty) = \left\{ \left[\frac{\partial M_\infty}{\partial p_\infty} U(p_\infty) \right]^2 + \left[\frac{\partial M_\infty}{\partial p_T} U(p_T) \right]^2 \right\}^{1/2} \quad (B12)$$

Equations (B5)–(B8) are used to obtain the sensitivity of the derived quantity with respect to each of the primary measurements. The uncertainty in Mach number is first determined with the nominal wind tunnel static and total pressures for representative Reynolds and Mach numbers. The sensitivity factors (i.e., quantities in partial derivatives) change as the values of the primary measure-

ments change based on test Reynolds and Mach numbers. The contributions of the static pressure and total pressure measurement to the calculated uncertainty in Mach number, normal-force coefficient, pitching-moment coefficient, and pressure coefficient are listed in tables B2–B5.

Table B2. Contribution of Primary Measurements to Mach Number Uncertainty

M_∞	R_{mac}	p_T psia	t_T °F	$\frac{\partial M_\infty}{\partial p_\infty} U(p_\infty)$	$\frac{\partial M_\infty}{\partial p_T} U(p_T)$	$U(M_\infty)$
0.40	6×10^6	66	120	-0.0004	0.0002	0.0005
.60	6	19.5	120	-.0003	.0002	.0003
.85	120	76	-250	-.0002	.0001	.0003
.90	6	15.5	120	-.0003	.0001	.0003

Table B3. Contribution of Primary Measurements to Normal-Force Coefficient Uncertainty

M_∞	R_{mac}	p_T psia	t_T °F	α , deg	$\frac{\partial C_N}{\partial F_N} U(F_N)$	$\frac{\partial C_N}{\partial p_\infty} U(p_\infty)$	$\frac{\partial C_N}{\partial M_\infty} U(M_\infty)$	$U(C_N)$
0.40	6×10^6	66.0	120	4.84	0.01187	-0.00003	0.00037	0.0119
				9.95	0.01189	-0.00008	-0.00080	0.0119
				20.17	0.01189	-0.00019	-0.00202	0.0121
0.60	6×10^6	19.5	120	4.99	0.02020	-0.00004	-0.00019	0.0202
				10.14	0.02020	-0.00009	-0.00045	0.0202
				20.26	0.02021	-0.00022	-0.00106	0.0202
0.85	120×10^6	76.0	-250	4.95	0.00323	-0.00005	-0.00012	0.0032
				10.34	0.00322	-0.00012	-0.00030	0.0032
				14.57	0.00323	-0.00017	-0.00044	0.0033
0.90	6×10^6	15.5	120	5.06	0.01501	-0.00007	-0.00015	0.0150
				10.20	0.01500	-0.00016	-0.00034	0.0150
				20.33	0.01503	-0.00034	-0.00074	0.0150

Table B4. Contribution of Primary Measurements to Pitching-Moment Coefficient Uncertainty

M_∞	R_{mac}	p_T , psia	t_T , °F	α , deg	$\frac{\partial C_m}{\partial M_Y} U(M_Y)$	$\frac{\partial C_m}{\partial p_\infty} U(p_\infty)$	$\frac{\partial C_m}{\partial M_\infty} U(M_\infty)$	$U(C_m)$
0.40	6×10^6	66.0	120	4.84	0.00000	0.00000	0.00005	0.0000
				9.95	0.00000	0.00001	0.00012	0.0001
				20.17	0.00000	0.00003	0.00027	0.0003
0.60	6×10^6	19.5	120	4.99	0.00000	0.00001	0.00003	0.0000
				10.14	0.00000	0.00001	0.00007	0.0001
				20.26	0.00000	0.00003	0.00014	0.0001
0.85	120×10^6	76.0	-250	4.95	0.00000	0.00001	0.00002	0.0000
				10.34	0.00000	0.00002	0.00005	0.0001
				14.57	0.00000	0.00003	0.00006	0.0001
0.90	6×10^6	15.5	120	5.06	0.00000	0.00001	0.00003	0.0000
				10.20	0.00000	0.00003	0.00007	0.0001
				20.33	0.00000	0.00007	0.00015	0.0002

Table B5. Contribution of Primary Measurements to Pressure Coefficient Uncertainty

M_∞	R_{mac}	p_T , psia	t_T , °F	α , deg	$\frac{\partial C_p}{\partial p} U(p)$	$\frac{\partial C_p}{\partial p_\infty} U(p_\infty)$	$\frac{\partial C_p}{\partial M_\infty} U(M_\infty)$	$U(C_p)$
0.40	6×10^6	66.0	120	4.84	0.00458	0.00001	0.01066	0.0116
				9.95	0.00459	0.00002	0.01077	0.0117
				20.17	0.00459	0.00007	0.01101	0.0119
0.60	6×10^6	19.5	120	4.99	0.00780	0.00002	0.00231	0.0081
				10.14	0.00780	0.00005	0.00238	0.0082
				20.26	0.00780	0.00010	0.00249	0.0082
0.85	120×10^6	76.0	-250	4.95	0.00125	0.00000	0.00062	0.0014
				10.34	0.00124	0.00001	0.00062	0.0014
				14.57	0.00125	0.00001	0.00063	0.0014
0.90	6×10^6	15.5	120	5.06	0.00580	0.00002	0.00064	0.0058
				10.20	0.00579	0.00006	0.00068	0.0058
				20.33	0.00580	0.00007	0.00070	0.0058

Appendix C

Experimental Surface Pressure Data for 65° Delta Wing, $M_\infty = 0.40$

The experimental surface pressure data for the 65° delta wing at constant $M_\infty = 0.40$ are summarized in tables C1–C3. Because of the extensive data contained in these tables, they have not been included in the printed copy of the paper but are available electronically from the Langley Technical Report Server (LTRS). Open the files with the following Uniform Resource Locator (URL):

<ftp://techreports.larc.nasa.gov/pub/techreports/larc/96/NASA-96-tm4645vol3appC.ps.Z>

Appendix D

Experimental Surface Pressure Data for 65° Delta Wing, $M_\infty = 0.60$

The experimental surface pressure data for the 65° delta wing at constant $M_\infty = 0.60$ are summarized in tables D1–D3. Because of the extensive data contained in these tables, they have not been included in the printed copy of the paper but are available electronically from the Langley Technical Report Server (LTRS). Open the files with the following Uniform Resource Locator (URL):

<ftp://techreports.larc.nasa.gov/pub/techreports/larc/96/NASA-96-tm4645vol3appD.ps.Z>

Appendix E

Experimental Surface Pressure Data for 65° Delta Wing, $M_\infty = 0.85$

The experimental surface pressure data for the 65° delta wing at constant $M_\infty = 0.85$ are summarized in tables E1–E11. Because of the extensive data contained in these tables, they have not been included in the printed copy of the paper but are available electronically from the Langley Technical Report Server (LTRS). Open the files with the following Uniform Resource Locator (URL):

<ftp://techreports.larc.nasa.gov/pub/techreports/larc/96/NASA-96-tm4645vol3appE.ps.Z>

Appendix F

Experimental Surface Pressure Data for 65° Delta Wing, $R_{\text{mac}} = 6 \times 10^6$

The experimental surface pressure data for the 65° delta wing at constant $R_{\text{mac}} = 6 \times 10^6$ are summarized in tables F1–F4. Because of the extensive data contained in these tables, they have not been included in the printed copy of the paper but are available electronically from the Langley Technical Report Server (LTRS). Open the files with the following Uniform Resource Locator (URL):

<ftp://techreports.larc.nasa.gov/pub/techreports/larc/96/NASA-96-tm4645vol3appF.ps.Z>

Appendix G

Experimental Surface Pressure Data for 65° Delta Wing, $R_{\text{mac}} = 60 \times 10^6$

The experimental surface pressure data for the 65° delta wing at constant $R_{\text{mac}} = 60 \times 10^6$ are summarized in tables G1–G4. Because of the extensive data contained in these tables, they have not been included in the printed copy of the paper but are available electronically from the Langley Technical Report Server (LTRS). Open the files with the following Uniform Resource Locator (URL):

<ftp://techreports.larc.nasa.gov/pub/techreports/larc/96/NASA-96-tm4645vol3appG.ps.Z>

Appendix H

Experimental Surface Pressure Data for 65° Delta Wing, $R_{\text{mac}} = 120 \times 10^6$

The experimental surface pressure data for the 65° delta wing at constant $R_{\text{mac}} = 120 \times 10^6$ are summarized in tables H1–H4. Because of the extensive data contained in these tables, they have not been included in the printed copy of the paper but are available electronically from the Langley Technical Report Server (LTRS). Open the files with the following Uniform Resource Locator (URL):

<ftp://techreports.larc.nasa.gov/pub/techreports/larc/96/NASA-96-tm4645vol3appH.ps.Z>

References

1. Winter, H.: *Flow Phenomena on Plates and Airfoils of Short Span*. NACA TM-798, 1936.
2. Wilson, Herbert A.; and Lovell, J. Calvin: *Full-Scale Investigation of the Maximum Lift and Flow Characteristics of an Airplane Having Approximately Triangular Plan Form*. NACA RM L6K20, 1947.
3. Örnberg, Torsten: *A Note On the Flow Around Delta Wings*. KTH-Aero TN 38, Div. of Aeronautics, R. Inst. of Technology (Stockholm), 1954.
4. Lawford, J. A.: *Low-Speed Wind Tunnel Experiments on a Series of Sharp-Edged Delta Wings—Part II. Surface Flow Patterns and Boundary Layer Transition Measurements*. Tech. Note Aero. 2954, R. Aircr. Establ., Mar. 1964.
5. Hummel, Ing. Dietrich: *On the Vortex Formation Over a Slender Wing at Large Angles of Incidence. High Angle of Attack Aerodynamics*, AGARD-CP-247, Jan. 1979, pp. 15-1-15-17.
6. Vorropoulos, G.; and Wendt, J. F.: *Laser Velocimetry Study of Compressibility Effects on the Flow Field of a Delta Wing. Aerodynamics of Vortical Type Flows in Three Dimensions*, AGARD-CP-342, July 1983, pp. 9-1-9-13. (Available from DTIC as AD A135 157.)
7. Poisson-Quinton, P.: *Slender Wings for Civil and Military Aircraft*. *Israel J. Technol.*, vol. 16, no. 3, 1978, pp. 97-131.
8. Skow, A. M.; and Erickson, G. E.: *Modern Fighter Aircraft Design for High-Angle-of-Attack Maneuvering. High Angle-of-Attack Aerodynamics*, AGARD-LS-121, Dec. 1982, pp. 4-1-4-59.
9. Polhamus, E. C.: *Applying Slender Wing Benefits to Military Aircraft*. *J. Aircr.*, vol. 21, no. 8, Aug. 1984, pp. 545-559.
10. Polhamus, E. C.; and Gloss, B. B.: *Configuration Aerodynamics. High Reynolds Number Research*, NASA CP-2183, 1980, pp. 217-234.
11. Henderson, William P.: *Effects of Wing Leading-Edge Radius and Reynolds Number on Longitudinal Aerodynamic Characteristics of Highly Swept Wing-Body Configurations at Subsonic Speeds*. NASA TN D-8361, 1976.
12. Howe, J. T.: *Some Fluid Mechanical Problems Related to Subsonic and Supersonic Aircraft*. NASA SP-183, 1969.
13. Henderson, William P.: *Studies of Various Factors Affecting Drag Due to Lift at Subsonic Speeds*. NASA TN D-3584, 1966.
14. Fuller, Dennis E.: *Guide for Users of the National Transonic Facility*. NASA TM-83124, 1981.
15. Plentovich, E. B.: *The Application to Airfoils of a Technique for Reducing Orifice-Induced Pressure Error at High Reynolds Numbers*. NASA TP-2537, 1986.
16. Hall, Robert M.; and Adcock, Jerry B.: *Simulation of Ideal-Gas Flow by Nitrogen and Other Selected Gases at Cryogenic Temperatures*. NASA TP-1901, 1981.
17. Holman, Jack Philip: *Experimental Methods for Engineers*. 4th ed., McGraw-Hill Book Co., 1984, pp. 46-99.
18. Foster, Jean M.; and Adcock, Jerry B.: *User's Guide for the National Transonic Facility Data System*. NASA TM-100511, 1987.

REPORT DOCUMENTATION PAGE			Form Approved OMB No. 0704-0188	
Public reporting burden for this collection of information is estimated to average 1 hour per response, including the time for reviewing instructions, searching existing data sources, gathering and maintaining the data needed, and completing and reviewing the collection of information. Send comments regarding this burden estimate or any other aspect of this collection of information, including suggestions for reducing this burden, to Washington Headquarters Services, Directorate for Information Operations and Reports, 1215 Jefferson Davis Highway, Suite 1204, Arlington, VA 22202-4302, and to the Office of Management and Budget, Paperwork Reduction Project (0704-0188), Washington, DC 20503.				
1. AGENCY USE ONLY (Leave blank)	2. REPORT DATE February 1996	3. REPORT TYPE AND DATES COVERED Technical Memorandum		
4. TITLE AND SUBTITLE Experimental Surface Pressure Data Obtained on 65° Delta Wing Across Reynolds Number and Mach Number Ranges Volume 3—Medium-Radius Leading Edge			5. FUNDING NUMBERS WU 505-59-54-01	
6. AUTHOR(S) Julio Chu and James M. Luckring				
7. PERFORMING ORGANIZATION NAME(S) AND ADDRESS(ES) NASA Langley Research Center Hampton, VA 23681-0001			8. PERFORMING ORGANIZATION REPORT NUMBER L-17411C	
9. SPONSORING/MONITORING AGENCY NAME(S) AND ADDRESS(ES) National Aeronautics and Space Administration Washington, DC 20546-0001			10. SPONSORING/MONITORING AGENCY REPORT NUMBER NASA TM-4645, Vol. 3	
11. SUPPLEMENTARY NOTES				
12a. DISTRIBUTION/AVAILABILITY STATEMENT Unclassified—Unlimited Subject Category 02 Availability: NASA CASI (301) 621-0390			12b. DISTRIBUTION CODE	
13. ABSTRACT (Maximum 200 words) An experimental wind tunnel test of a 65° delta wing model with interchangeable leading edges was conducted in the Langley National Transonic Facility (NTF). The objective was to investigate the effects of Reynolds and Mach numbers on slender-wing leading-edge vortex flows with four values of wing leading-edge bluntness. Experimentally obtained pressure data are presented without analysis in tabulated and graphical formats across a Reynolds number range of 6×10^6 to 120×10^6 at a Mach number of 0.85 and across a Mach number range of 0.4 to 0.9 at Reynolds numbers of 6×10^6 , 60×10^6 , and 120×10^6 . Normal-force and pitching-moment coefficient plots for these Reynolds number and Mach number ranges are also presented.				
14. SUBJECT TERMS Aerodynamics; Delta wing; Reynolds number; Leading-edge bluntness; Vortex flow; Cryogenic testing			15. NUMBER OF PAGES 37	
			16. PRICE CODE A03	
17. SECURITY CLASSIFICATION OF REPORT Unclassified	18. SECURITY CLASSIFICATION OF THIS PAGE Unclassified	19. SECURITY CLASSIFICATION OF ABSTRACT Unclassified	20. LIMITATION OF ABSTRACT	

Appendix C

Experimental Surface Pressure Data for 65° Delta Wing, $M_\infty = 0.40$

The experimental surface pressure data for the 65° delta wing at constant $M_\infty = 0.40$ are summarized in tables C1–C3. Because of the extensive data contained in these tables, they have not been included in the printed copy of the paper but are available electronically from the Langley Technical Report Server (LTRS). Open the files with the following Uniform Resource Locator (URL):

<ftp://techreports.larc.nasa.gov/pub/techreports/larc/96/NASA-96-tm4645vol3appC.ps.Z>

Table C1. Tabulations and Plots of Surface Pressure Coefficients.

η	x/c_R .2	$C_{p,u}$	x/c_R .4	$C_{p,u}$	x/c_R .6	$C_{p,u}$	x/c_R .8	$C_{p,u}$	x/c_R .95	$C_{p,u}$
0.050	-0.0001	-0.0012	0.1048	0.1048	0.1048	0.1048	0.1048	0.1048	0.1048	0.1048
0.100	-0.0068	0.0055	0.0883	0.0883	0.0883	0.0883	0.0883	0.0883	0.0883	0.0883
0.150	-0.0143	0.0065	0.0749	0.0749	0.0749	0.0749	0.0749	0.0749	0.0749	0.0749
0.200	-0.0123	0.0075	0.0628	0.0628	0.0628	0.0628	0.0628	0.0628	0.0628	0.0628
0.250	*****	0.0011	0.0488	-0.0866	-0.2690	-0.2690	-0.2690	-0.2690	-0.2690	-0.2690
0.300	-0.0223	0.0098	0.0401	-0.0768	-0.2856	-0.2856	-0.2856	-0.2856	-0.2856	-0.2856
0.350	*****	-0.0009	0.0281	-0.0683	-0.2889	-0.2889	-0.2889	-0.2889	-0.2889	-0.2889
0.400	-0.0323	0.0044	0.0329	-0.0631	-0.3013	-0.3013	-0.3013	-0.3013	-0.3013	-0.3013
0.450	-0.0406	-0.0073	0.0234	-0.0606	-0.3043	-0.3043	-0.3043	-0.3043	-0.3043	-0.3043
0.500	-0.0507	0.0044	0.0140	-0.0582	-0.3102	-0.3102	-0.3102	-0.3102	-0.3102	-0.3102
0.525	*****	-0.0010	0.0103	-0.0598	-0.3118	-0.3118	-0.3118	-0.3118	-0.3118	-0.3118
0.550	-0.0523	-0.0016	0.0033	-0.0620	-0.3108	-0.3108	-0.3108	-0.3108	-0.3108	-0.3108
0.575	*****	-0.0036	0.0113	-0.0543	-0.3199	-0.3199	-0.3199	-0.3199	-0.3199	-0.3199
0.600	-0.0576	-0.0136	-0.0033	-0.0583	-0.3183	-0.3183	-0.3183	-0.3183	-0.3183	-0.3183
0.625	*****	*****	-0.0037	-0.0559	-0.3290	-0.3290	-0.3290	-0.3290	-0.3290	-0.3290
0.650	-0.0582	-0.0296	-0.0078	-0.0535	-0.3261	-0.3261	-0.3261	-0.3261	-0.3261	-0.3261
0.675	*****	-0.0364	-0.0079	-0.0622	-0.3178	-0.3178	-0.3178	-0.3178	-0.3178	-0.3178
0.700	-0.0531	-0.0419	-0.0049	-0.0582	-0.3180	-0.3180	-0.3180	-0.3180	-0.3180	-0.3180
0.725	*****	-0.0450	*****	-0.0561	-0.3220	-0.3220	-0.3220	-0.3220	-0.3220	-0.3220
0.750	-0.0453	-0.0535	*****	-0.0594	-0.3113	-0.3113	-0.3113	-0.3113	-0.3113	-0.3113
0.775	*****	-0.0574	-0.0379	-0.0629	-0.3035	-0.3035	-0.3035	-0.3035	-0.3035	-0.3035
0.800	-0.0314	-0.0629	-0.0564	-0.0785	*****	*****	*****	*****	*****	*****
0.825	*****	-0.0644	-0.0572	-0.0837	-0.3360	-0.3360	-0.3360	-0.3360	-0.3360	-0.3360
0.850	-0.0071	-0.0587	-0.0792	-0.0962	-0.3626	-0.3626	-0.3626	-0.3626	-0.3626	-0.3626
0.875	*****	-0.0526	-0.0752	-0.1062	-0.4196	-0.4196	-0.4196	-0.4196	-0.4196	-0.4196
0.900	0.0244	-0.0342	-0.0717	-0.1155	-0.5198	-0.5198	-0.5198	-0.5198	-0.5198	-0.5198
0.925	*****	-0.0176	-0.0526	-0.1077	-0.8236	-0.8236	-0.8236	-0.8236	-0.8236	-0.8236
0.950	0.0709	0.0168	-0.0252	-0.0802	-0.4779	-0.4779	-0.4779	-0.4779	-0.4779	-0.4779
0.975	*****	0.0676	0.0316	-0.0230	-0.2497	-0.2497	-0.2497	-0.2497	-0.2497	-0.2497
1.000	0.1895	0.1678	0.1370	0.1321	0.0798	0.0798	0.0798	0.0798	0.0798	0.0798
-0.200	-0.0300	-0.0111	0.0488	*****	-0.2470	-0.2470	-0.2470	-0.2470	-0.2470	-0.2470
-0.400	-0.0575	-0.0098	0.0102	-0.0743	-0.2950	-0.2950	-0.2950	-0.2950	-0.2950	-0.2950
-0.600	-0.0872	-0.0378	-0.0126	-0.0730	-0.3094	-0.3094	-0.3094	-0.3094	-0.3094	-0.3094
-0.700	-0.0861	-0.0720	-0.0350	-0.0775	-0.3436	-0.3436	-0.3436	-0.3436	-0.3436	-0.3436
-0.800	-0.0765	-0.0999	-0.0827	-0.0937	-0.3719	-0.3719	-0.3719	-0.3719	-0.3719	-0.3719
-0.850	-0.0622	-0.1036	-0.1056	-0.1317	-0.4238	-0.4238	-0.4238	-0.4238	-0.4238	-0.4238
-0.900	*****	-0.0967	-0.1243	-0.1641	-0.5961	-0.5961	-0.5961	-0.5961	-0.5961	-0.5961
-0.950	0.0154	-0.0526	-0.0949	-0.1518	-0.5033	-0.5033	-0.5033	-0.5033	-0.5033	-0.5033
-0.975	*****	-0.0014	-0.0458	-0.0999	-0.3022	-0.3022	-0.3022	-0.3022	-0.3022	-0.3022
-1.000	0.1803	0.1690	0.1371	0.1271	0.0869	0.0869	0.0869	0.0869	0.0869	0.0869

Medium Radius L.E.
 Run No. = 3, Point No. = 37
 $C_N = -0.023$, $C_m = 0.0024$
 $\alpha = -0.4^\circ$, $M_\infty = 0.400$
 $R_{mac} = 6.0 \times 10^6$

Leading Edge Pressures

- starboard
- port

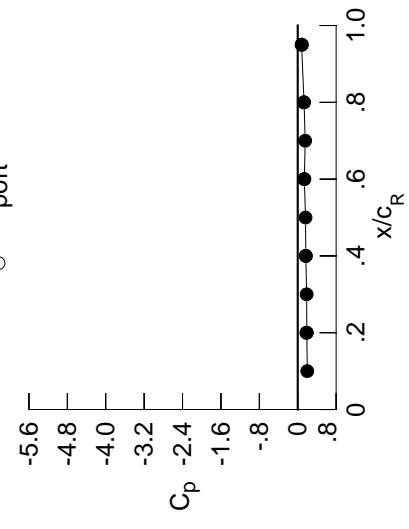

x/c_R	starb'd C_p	port C_p
0.10	0.1991	*****
0.20	0.1895	0.1803
0.30	0.1853	*****
0.40	0.1678	0.1690
0.50	0.1628	*****
0.60	0.1370	0.1371
0.70	0.1555	*****
0.80	0.1321	0.1271
0.90	*****	*****
0.95	0.0798	0.0869

Surface Pressures

- upper, starboard
- lower, port

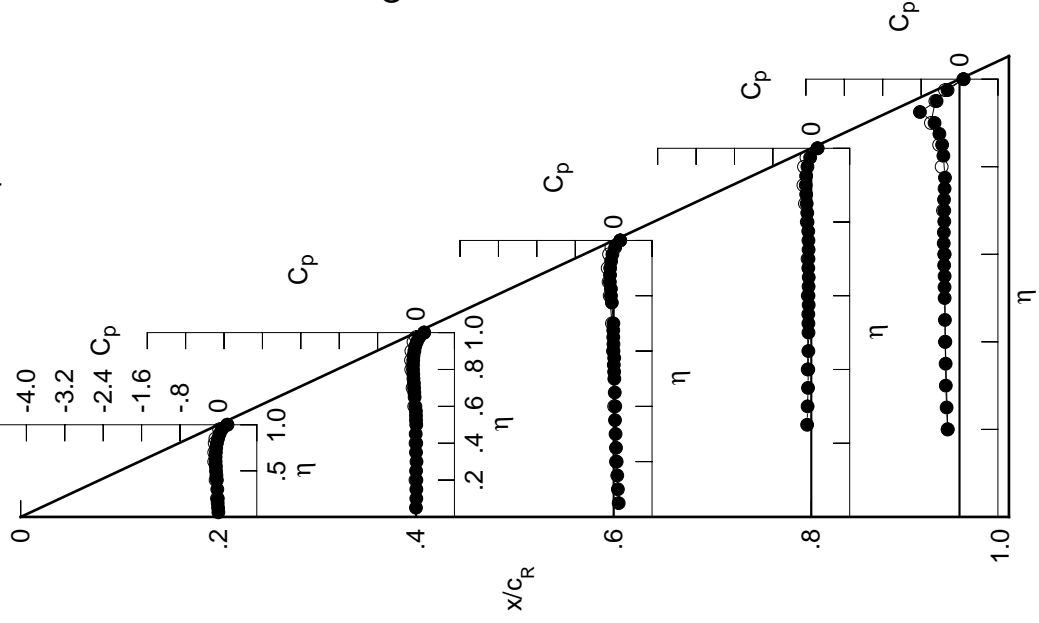
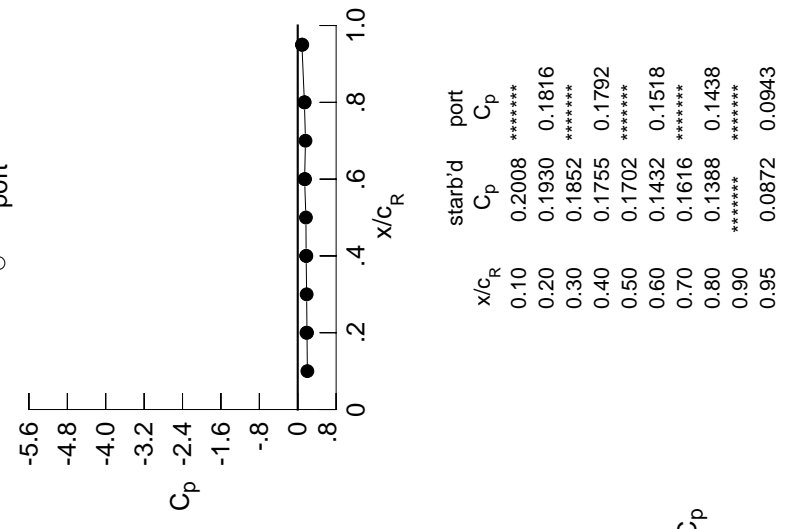

Table C1. Continued.

η	x/c_R .2	x/c_R .4	x/c_R .6	x/c_R .8	x/c_R .95
	$C_{p,u}$	$C_{p,u}$	$C_{p,u}$	$C_{p,u}$	$C_{p,u}$
0.050	-0.0140	-0.0048	0.1002	*****	*****
0.100	-0.0158	0.0011	0.0797	*****	*****
0.150	-0.0228	-0.0022	0.0699	*****	*****
0.200	-0.0208	-0.0031	0.0509	*****	-0.2517
0.250	*****	-0.0019	0.0494	-0.0928	-0.2704
0.300	-0.0343	-0.0040	0.0269	-0.0826	-0.2877
0.350	*****	-0.0047	0.0236	-0.0771	-0.2894
0.400	-0.0420	-0.0087	0.0220	-0.0692	-0.3045
0.450	-0.0530	-0.0086	0.0178	-0.0633	-0.3033
0.500	-0.0625	-0.0078	0.0112	-0.0659	-0.3153
0.525	*****	-0.0069	-0.0010	-0.0657	-0.3031
0.550	-0.0612	-0.0133	0.0009	-0.0634	-0.3152
0.575	*****	-0.0121	-0.0004	-0.0635	-0.3133
0.600	-0.0720	-0.0118	-0.0100	-0.0598	-0.3189
0.625	*****	*****	-0.0099	-0.0668	-0.3249
0.650	-0.0714	-0.0464	-0.0148	-0.0642	-0.3226
0.675	*****	-0.0464	-0.0114	-0.0695	-0.3216
0.700	-0.0697	-0.0490	-0.0175	-0.0670	-0.3161
0.725	*****	-0.0593	*****	-0.0645	-0.3244
0.750	-0.0578	-0.0718	*****	-0.0631	-0.3194
0.775	*****	-0.0747	-0.0565	-0.0706	-0.3057
0.800	-0.0503	-0.0813	-0.0674	-0.0891	*****
0.825	*****	-0.0768	-0.0776	-0.0926	-0.3441
0.850	-0.0239	-0.0838	-0.0887	-0.1103	-0.3702
0.875	*****	-0.0677	-0.0982	-0.1243	-0.4215
0.900	0.0049	-0.0608	-0.0926	-0.1306	-0.5349
0.925	*****	-0.0376	-0.0754	-0.1305	-0.8388
0.950	0.0516	-0.0099	-0.0534	-0.1060	-0.4934
0.975	*****	0.0417	0.0037	-0.0558	-0.2708
1.000	0.1930	0.1755	0.1432	0.1388	0.0872
	$C_{p,l}$	$C_{p,l}$	$C_{p,l}$	$C_{p,l}$	$C_{p,l}$
-0.200	-0.0287	-0.0085	0.0565	*****	-0.2462
-0.400	-0.0457	-0.0035	0.0113	-0.0741	-0.3024
-0.600	-0.0774	-0.0333	-0.0059	-0.0699	-0.3155
-0.700	-0.0736	-0.0607	-0.0273	-0.0774	-0.3474
-0.800	-0.0597	-0.0863	-0.0684	-0.0890	-0.3767
-0.850	-0.0436	-0.0859	-0.0923	-0.1183	-0.4258
-0.900	*****	-0.0765	-0.1023	-0.1487	-0.5864
-0.950	0.0389	-0.0276	-0.0681	-0.1290	-0.4940
-0.975	*****	0.0259	-0.0152	-0.0713	-0.2852
-1.000	0.1816	0.1792	0.1518	0.1438	0.0943

Medium Radius L.E.
 Run No. = 3, Point No. = 38
 $C_N = -0.008$, $C_m = 0.0008$
 $\alpha = 0.1^\circ$, $M_\infty = 0.400$
 $R_{mac} = 5.9 \times 10^6$

Leading Edge Pressures
 ● starboard
 ○ port



x/c_R	starb'd C_p	port C_p
0.10	0.2008	*****
0.20	0.1930	0.1816
0.30	0.1852	*****
0.40	0.1755	0.1792
0.50	0.1702	*****
0.60	0.1432	0.1518
0.70	0.1616	*****
0.80	0.1388	0.1438
0.90	*****	*****
0.95	0.0872	0.0943

Table C1. Continued.

η	x/c_R	$C_{p,u}$	x/c_R	$C_{p,u}$	x/c_R	$C_{p,u}$	x/c_R	$C_{p,u}$	x/c_R	$C_{p,u}$
0.050	0.2	-0.0299	0.4	-0.0209	0.6	0.0874	0.8	0.0668	0.95	0.0668
0.100		-0.0330		-0.0147		0.0743		0.0307		0.0306
0.150		-0.0409		-0.0157		0.0514		0.0104		0.0185
0.200		-0.0432		-0.0173		0.0432		0.0019		0.3431
0.250		*****		-0.0203		0.0354		-0.0303		-0.3690
0.300		-0.0542		-0.0142		0.0193		-0.0596		-0.4185
0.350		*****		-0.0238		0.0132		-0.0640		-0.4185
0.400		-0.0697		-0.0210		0.0106		-0.0720		-0.4518
0.450		-0.0799		-0.0297		0.0052		-0.0724		-0.5505
0.500		-0.0885		-0.0237		-0.0068		-0.0744		-0.5505
0.525		*****		-0.0288		-0.0110		-0.0724		-0.5505
0.550		-0.0873		-0.0301		-0.0176		-0.0763		-0.5505
0.575		*****		-0.0337		-0.0134		-0.0670		-0.5505
0.600		-0.1006		-0.0308		-0.0249		-0.0740		-0.5505
0.625		*****		*****		-0.0282		-0.0717		-0.5505
0.650		-0.1046		-0.0710		-0.0312		-0.0724		-0.5505
0.675		*****		-0.0804		-0.0349		-0.0817		-0.5505
0.700		-0.1041		-0.0851		-0.0346		-0.0781		-0.5505
0.725		*****		-0.0873		*****		-0.0729		-0.5505
0.750		-0.0972		-0.1015		*****		-0.0819		-0.5505
0.775		*****		-0.1077		-0.0818		-0.0877		-0.5505
0.800		-0.0914		-0.1182		-0.1067		-0.0955		-0.5505
0.825		*****		-0.1216		-0.1045		-0.1273		-0.5505
0.850		-0.0705		-0.1240		-0.1322		-0.1407		-0.5505
0.875		*****		-0.1161		-0.1368		-0.1581		-0.5505
0.900		-0.0443		-0.1122		-0.1431		-0.1701		-0.5505
0.925		*****		-0.0994		-0.1314		-0.1816		-0.5505
0.950		-0.0023		-0.0731		-0.1227		-0.1606		-0.5505
0.975		*****		-0.0257		-0.0710		-0.1272		-0.5505
1.000		0.1739		0.1472		0.1222		0.1152		0.0952
η	$C_{p,l}$	$C_{p,l}$	$C_{p,l}$	$C_{p,l}$	$C_{p,l}$	$C_{p,l}$	$C_{p,l}$	$C_{p,l}$	$C_{p,l}$	$C_{p,l}$
-0.200	-0.0062	0.0161	0.0668	0.0668	0.0668	0.0668	0.0668	0.0668	0.0668	0.0668
-0.400	-0.0246	0.0158	0.0307	0.0307	0.0307	0.0307	0.0307	0.0307	0.0307	0.0307
-0.600	-0.0446	-0.0053	0.0104	-0.0561	-0.3185	-0.3185	-0.3185	-0.3185	-0.3185	-0.3185
-0.700	-0.0376	-0.0318	-0.0019	-0.0596	-0.3431	-0.3431	-0.3431	-0.3431	-0.3431	-0.3431
-0.800	-0.0178	-0.0481	-0.0303	-0.0640	-0.3690	-0.3690	-0.3690	-0.3690	-0.3690	-0.3690
-0.850	0.0003	-0.0428	-0.0517	-0.0870	-0.4185	-0.4185	-0.4185	-0.4185	-0.4185	-0.4185
-0.900	*****	-0.0239	-0.0543	-0.1065	-0.5505	-0.5505	-0.5505	-0.5505	-0.5505	-0.5505
-0.950	0.0880	0.0296	-0.0079	-0.0720	-0.4518	-0.4518	-0.4518	-0.4518	-0.4518	-0.4518
-0.975	*****	0.0885	0.0511	-0.0048	-0.2358	-0.2358	-0.2358	-0.2358	-0.2358	-0.2358
-1.000	0.1810	0.1691	0.1387	0.1387	0.1387	0.1387	0.1387	0.1387	0.1387	0.0952

Medium Radius L.E.
 Run No. = 3, Point No. = 39
 $C_N = 0.028$, $C_m = -0.0045$
 $\alpha = 1.1^\circ$, $M_\infty = 0.400$
 $R_{mac} = 5.9 \times 10^6$

Leading Edge Pressures

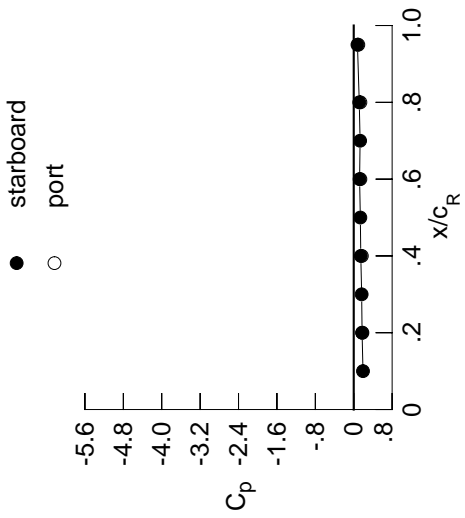

x/c_R	starb'd C_p	port C_p
0.10	0.1928	*****
0.20	0.1739	0.1810
0.30	0.1652	*****
0.40	0.1472	0.1691
0.50	0.1375	*****
0.60	0.1222	0.1387
0.70	0.1325	*****
0.80	0.1152	0.1387
0.90	*****	*****
0.95	0.0777	0.0952

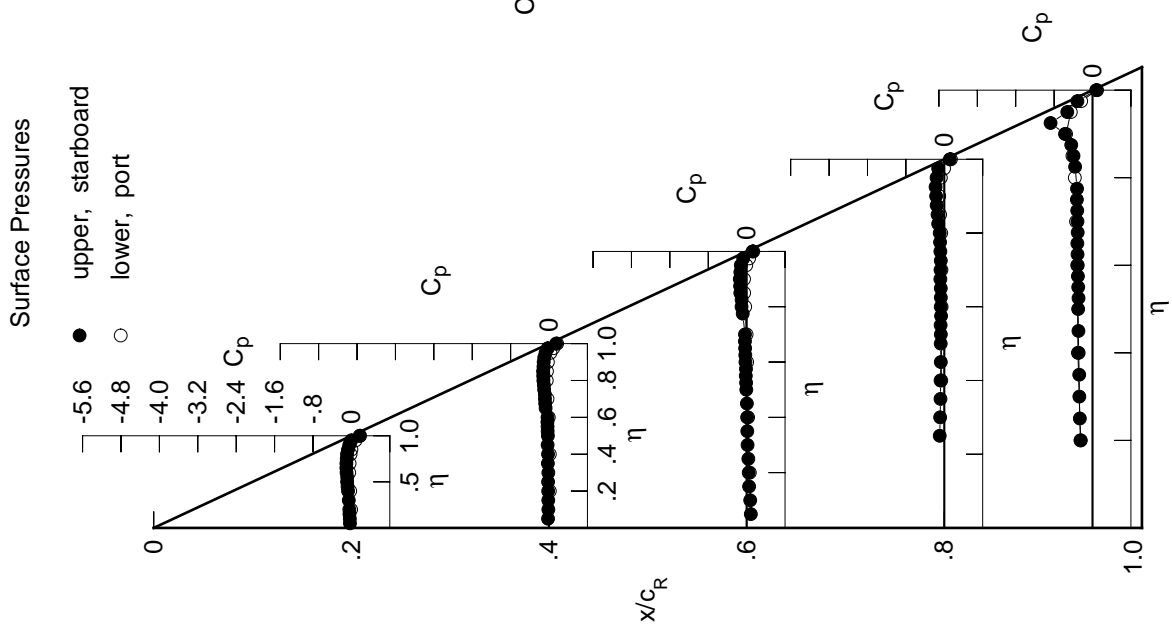

Table C1. Continued.

η	x/c_R	x/c_R	x/c_R	x/c_R	x/c_R	x/c_R	x/c_R
	$C_{p,u}$	$C_{p,u}$	$C_{p,u}$	$C_{p,u}$	$C_{p,u}$	$C_{p,u}$	$C_{p,u}$
0.050	-0.0528	-0.0386	0.0778	*****	*****	*****	*****
0.100	-0.0490	-0.0304	0.0615	*****	*****	*****	*****
0.150	-0.0591	-0.0304	0.0447	*****	*****	*****	*****
0.200	-0.0624	-0.0342	0.0322	*****	*****	*****	-0.2489
0.250	*****	-0.0369	0.0223	-0.0994	-0.2560	*****	*****
0.300	-0.0696	-0.0351	0.0065	-0.0948	-0.2659	*****	*****
0.350	*****	-0.0416	-0.0027	-0.0875	-0.2678	*****	*****
0.400	-0.0861	-0.0433	-0.0028	-0.0873	-0.2771	*****	*****
0.450	-0.0988	-0.0524	-0.0119	-0.0770	-0.2762	*****	*****
0.500	-0.1091	-0.0483	-0.0198	-0.0838	-0.2840	*****	*****
0.525	*****	-0.0528	-0.0298	-0.0795	-0.2768	*****	*****
0.550	-0.1085	-0.0607	-0.0324	-0.0853	-0.2821	*****	*****
0.575	*****	-0.0653	-0.0357	-0.0789	-0.2816	*****	*****
0.600	-0.1256	-0.0652	-0.0412	-0.0883	-0.2859	*****	*****
0.625	*****	*****	-0.0485	-0.0823	-0.2892	*****	*****
0.650	-0.1298	-0.0806	-0.0538	-0.0858	-0.2897	*****	*****
0.675	*****	-0.0909	-0.0568	-0.1034	-0.2806	*****	*****
0.700	-0.1370	-0.1033	-0.0617	-0.0908	-0.2820	*****	*****
0.725	*****	-0.1102	*****	-0.0928	-0.2829	*****	*****
0.750	-0.1332	-0.1337	*****	-0.1028	-0.2759	*****	*****
0.775	*****	-0.1361	-0.0982	-0.1155	-0.2590	*****	*****
0.800	-0.1268	-0.1509	-0.1236	-0.1256	*****	*****	*****
0.825	*****	-0.1593	-0.1345	-0.1335	-0.2885	*****	*****
0.850	-0.1118	-0.1607	-0.1649	-0.1580	-0.3017	*****	*****
0.875	*****	-0.1631	-0.1764	-0.1892	-0.3773	*****	*****
0.900	-0.0931	-0.1628	-0.1852	-0.2116	-0.4872	*****	*****
0.925	*****	-0.1570	-0.1859	-0.2259	-0.9122	*****	*****
0.950	-0.0619	-0.1353	-0.1778	-0.2183	-0.5728	*****	*****
0.975	*****	-0.1106	-0.1497	-0.1978	-0.3784	*****	*****
1.000	0.1278	0.0717	0.0489	0.0213	0.0116	*****	*****
	$C_{p,l}$	$C_{p,l}$	$C_{p,l}$	$C_{p,l}$	$C_{p,l}$	$C_{p,l}$	$C_{p,l}$
-0.200	0.0157	0.0260	0.0763	*****	-0.2634	*****	*****
-0.400	-0.0007	0.0339	0.0435	-0.0584	-0.3062	*****	*****
-0.600	-0.0153	0.0141	0.0244	-0.0453	-0.3265	*****	*****
-0.700	-0.0035	-0.0021	0.0162	-0.0473	-0.3364	*****	*****
-0.800	0.0203	-0.0127	-0.0040	-0.0514	-0.3502	*****	*****
-0.850	0.0420	-0.0009	-0.0223	-0.0570	-0.3886	*****	*****
-0.900	*****	0.0216	-0.0113	-0.0698	-0.5020	*****	*****
-0.950	0.1303	0.0781	0.0444	-0.0211	-0.4020	*****	*****
-0.975	*****	0.1346	0.1035	0.0484	-0.1882	*****	*****
-1.000	0.1364	0.1012	0.0547	0.0591	0.0480	*****	*****

Medium Radius L.E.
 Run No. = 3, Point No. = 40
 $C_N = 0.065$, $C_m = -0.0107$
 $\alpha = 2.2^\circ$, $M_\infty = 0.400$
 $R_{mac} = 5.9 \times 10^6$

Leading Edge Pressures

● starboard
 ○ port

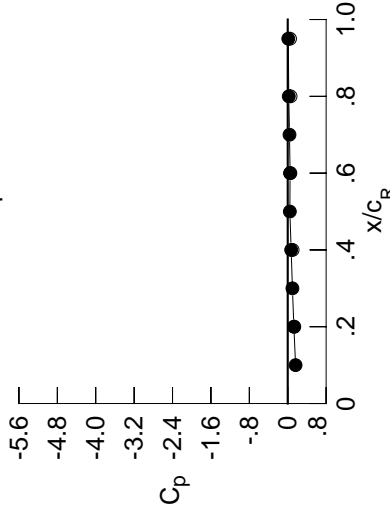

x/c_R	starb'd C_p	port C_p
0.10	0.1636	*****
0.20	0.1278	0.1364
0.30	0.0977	*****
0.40	0.0717	0.1012
0.50	0.0441	*****
0.60	0.0489	0.0547
0.70	0.0367	*****
0.80	0.0213	0.0591
0.90	*****	*****
0.95	0.0116	0.0480

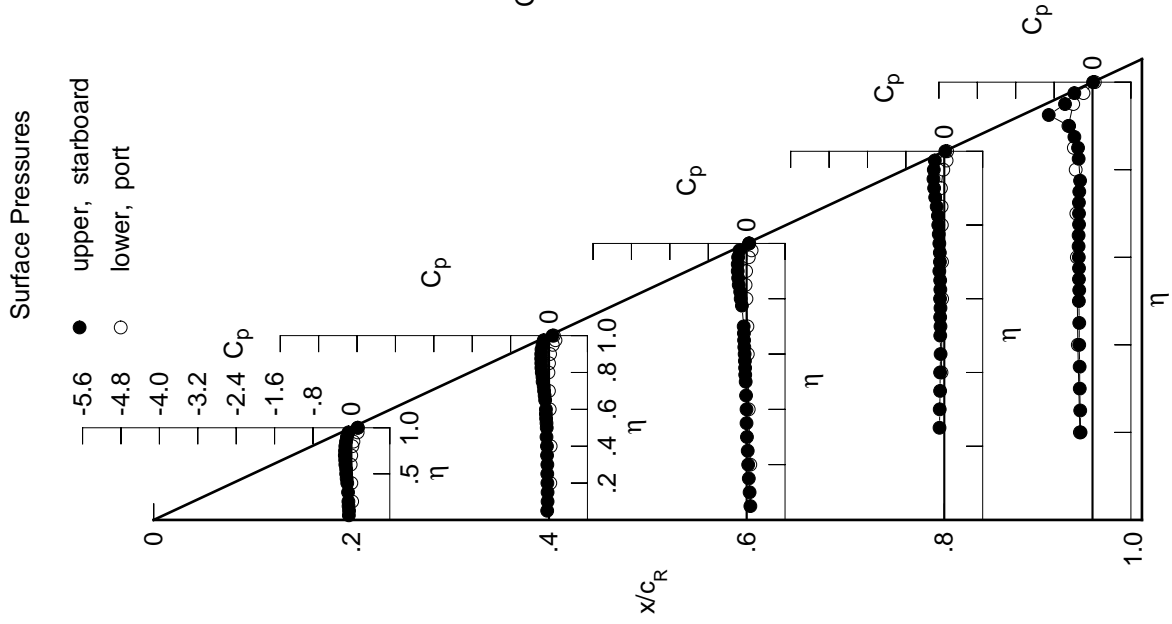
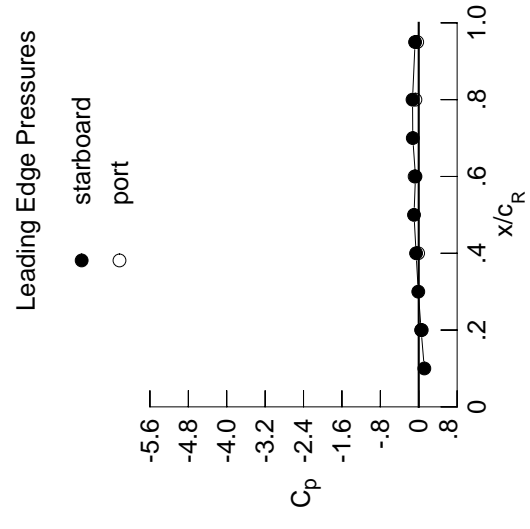

Table C1. Continued.

η	x/c_R .2	x/c_R .4	x/c_R .6	x/c_R .8	x/c_R .95
	$C_{p,u}$	$C_{p,u}$	$C_{p,u}$	$C_{p,u}$	$C_{p,u}$
0.050	-0.0675	-0.0477	0.0662	*****	*****
0.100	-0.0675	-0.0451	0.0535	*****	*****
0.150	-0.0787	-0.0437	0.0352	*****	*****
0.200	-0.0811	-0.0508	0.0222	*****	-0.2417
0.250	*****	-0.0523	0.0142	-0.1075	-0.2502
0.300	-0.0930	-0.0506	-0.0003	-0.0977	-0.2568
0.350	*****	-0.0554	-0.0125	-0.0923	-0.2607
0.400	-0.1112	-0.0570	-0.0139	-0.0871	-0.2661
0.450	-0.1188	-0.0614	-0.0217	-0.0831	-0.2657
0.500	-0.1309	-0.0657	-0.0347	-0.0903	-0.2711
0.525	*****	-0.0709	-0.0430	-0.0895	-0.2648
0.550	-0.1347	-0.0811	-0.0469	-0.0902	-0.2708
0.575	*****	-0.0828	-0.0441	-0.0856	-0.2753
0.600	-0.1538	-0.0857	-0.0600	-0.0937	-0.2779
0.625	*****	*****	-0.0614	-0.0966	-0.2807
0.650	-0.1615	-0.1056	-0.0708	-0.0979	-0.2803
0.675	*****	-0.1162	-0.0735	-0.1068	-0.2720
0.700	-0.1697	-0.1319	-0.0861	-0.1055	-0.2691
0.725	*****	-0.1400	*****	-0.1045	-0.2684
0.750	-0.1708	-0.1649	*****	-0.1146	-0.2599
0.775	*****	-0.1739	-0.1219	-0.1289	-0.2431
0.800	-0.1690	-0.1898	-0.1501	-0.1433	*****
0.825	*****	-0.1993	-0.1632	-0.1517	-0.2695
0.850	-0.1584	-0.2085	-0.2025	-0.1846	-0.2835
0.875	*****	-0.2153	-0.2203	-0.2198	-0.3672
0.900	-0.1424	-0.2211	-0.2452	-0.2487	-0.4835
0.925	*****	-0.2229	-0.2429	-0.2751	-0.9256
0.950	-0.1251	-0.2090	-0.2579	-0.2851	-0.6082
0.975	*****	-0.2021	-0.2397	-0.2805	-0.4419
1.000	0.0497	-0.0549	-0.0680	-0.1293	-0.0764
	$C_{p,l}$	$C_{p,l}$	$C_{p,l}$	$C_{p,l}$	$C_{p,l}$
-0.200	0.0337	0.0423	0.0851	*****	-0.2611
-0.400	0.0244	0.0472	0.0582	-0.0496	-0.3124
-0.600	0.0181	0.0393	0.0396	-0.0360	-0.3338
-0.700	0.0333	0.0242	0.0314	-0.0366	-0.3499
-0.800	0.0610	0.0229	0.0213	-0.0315	-0.3689
-0.850	0.0814	0.0383	0.0186	-0.0351	-0.4055
-0.900	*****	0.0653	0.0297	-0.0315	-0.4918
-0.950	0.1648	0.1224	0.0875	0.0208	-0.3753
-0.975	*****	0.1691	0.1426	0.0920	-0.1564
-1.000	0.0624	-0.0125	-0.0852	-0.0692	-0.0322

Medium Radius L.E.
 Run No. = 3, Point No. = 41
 $C_N = 0.092$, $C_m = -0.0096$
 $\alpha = 3.2^\circ$, $M_\infty = 0.400$
 $R_{mac} = 5.9 \times 10^6$



Leading Edge Pressures

x/c_R	starboard C_p	port C_p
0.10	0.1168	*****
0.20	0.0497	0.0624
0.30	-0.0095	*****
0.40	-0.0549	-0.0125
0.50	-0.0983	*****
0.60	-0.0680	-0.0852
0.70	-0.1240	*****
0.80	-0.1293	-0.0692
0.90	*****	*****
0.95	-0.0764	-0.0322

Table C1. Continued.

η	x/c_R	x/c_R	x/c_R	x/c_R	x/c_R	x/c_R	x/c_R
	$C_{p,u}$	$C_{p,u}$	$C_{p,u}$	$C_{p,u}$	$C_{p,u}$	$C_{p,u}$	$C_{p,u}$
0.050	-0.0829	-0.0607	0.0626	*****	*****	*****	*****
0.100	-0.0805	-0.0593	0.0457	*****	*****	*****	*****
0.150	-0.0968	-0.0624	0.0287	*****	*****	*****	*****
0.200	-0.0980	-0.0615	0.0148	*****	*****	*****	*****
0.250	*****	-0.0623	0.0045	-0.1105	-0.2463	-0.2400	-0.2400
0.300	-0.1148	-0.0638	-0.0116	-0.0996	-0.2503	-0.2503	-0.2503
0.350	*****	-0.0725	-0.0224	-0.0982	-0.2448	-0.2448	-0.2448
0.400	-0.1315	-0.0717	-0.0220	-0.0940	-0.2598	-0.2598	-0.2598
0.450	-0.1431	-0.0854	-0.0356	-0.0871	-0.2555	-0.2555	-0.2555
0.500	-0.1549	-0.0819	-0.0441	-0.0948	-0.2616	-0.2616	-0.2616
0.525	*****	-0.0910	-0.0540	-0.0970	-0.2551	-0.2551	-0.2551
0.550	-0.1610	-0.0975	-0.0629	-0.0974	-0.2591	-0.2591	-0.2591
0.575	*****	-0.1011	-0.0610	-0.0927	-0.2620	-0.2620	-0.2620
0.600	-0.1838	-0.1083	-0.0720	-0.1030	-0.2654	-0.2654	-0.2654
0.625	*****	*****	-0.0805	-0.1035	-0.2681	-0.2681	-0.2681
0.650	-0.1942	-0.1317	-0.0893	-0.1074	-0.2666	-0.2666	-0.2666
0.675	*****	-0.1390	-0.0937	-0.1200	-0.2601	-0.2601	-0.2601
0.700	-0.2058	-0.1617	-0.1019	-0.1180	-0.2589	-0.2589	-0.2589
0.725	*****	-0.1687	*****	-0.1177	-0.2558	-0.2558	-0.2558
0.750	-0.2122	-0.1973	*****	-0.1337	-0.2446	-0.2446	-0.2446
0.775	*****	-0.2103	-0.1491	-0.1457	-0.2237	-0.2237	-0.2237
0.800	-0.2150	-0.2280	-0.1821	-0.1659	*****	*****	*****
0.825	*****	-0.2454	-0.1996	-0.1794	-0.2470	-0.2470	-0.2470
0.850	-0.2098	-0.2589	-0.2436	-0.2102	-0.2717	-0.2717	-0.2717
0.875	*****	-0.2726	-0.2686	-0.2517	-0.3560	-0.3560	-0.3560
0.900	-0.2022	-0.2809	-0.2975	-0.2922	-0.4827	-0.4827	-0.4827
0.925	*****	-0.2971	-0.3111	-0.3317	-0.9482	-0.9482	-0.9482
0.950	-0.2002	-0.2901	-0.3405	-0.3540	-0.6504	-0.6504	-0.6504
0.975	*****	-0.3118	-0.3442	-0.3759	-0.5033	-0.5033	-0.5033
1.000	-0.0637	-0.2357	-0.2435	-0.3413	-0.2129	-0.2129	-0.2129
-0.200	0.0555	0.0601	0.1030	*****	-0.2623	-0.2623	-0.2623
-0.400	0.0471	0.0669	0.0678	-0.0403	-0.3184	-0.3184	-0.3184
-0.600	0.0433	0.0543	0.0564	-0.0279	-0.3432	-0.3432	-0.3432
-0.700	0.0630	0.0512	0.0494	-0.0193	-0.3613	-0.3613	-0.3613
-0.800	0.0921	0.0531	0.0458	-0.0146	-0.3782	-0.3782	-0.3782
-0.850	0.1130	0.0719	0.0505	-0.0125	-0.4110	-0.4110	-0.4110
-0.900	*****	0.1006	0.0627	-0.0009	-0.4852	-0.4852	-0.4852
-0.950	0.1884	0.1524	0.1235	0.0571	-0.3420	-0.3420	-0.3420
-0.975	*****	0.1892	0.1662	0.1209	-0.1226	-0.1226	-0.1226
-1.000	-0.0486	-0.1814	-0.2990	-0.2718	-0.1400	-0.1400	-0.1400

Medium Radius L.E.
 Run No. = 3, Point No. = 42
 $C_N = 0.132$, $C_m = -0.0200$
 $\alpha = 4.2^\circ$, $M_\infty = 0.400$
 $R_{mac} = 5.9 \times 10^6$

Leading Edge Pressures

- starboard
- port

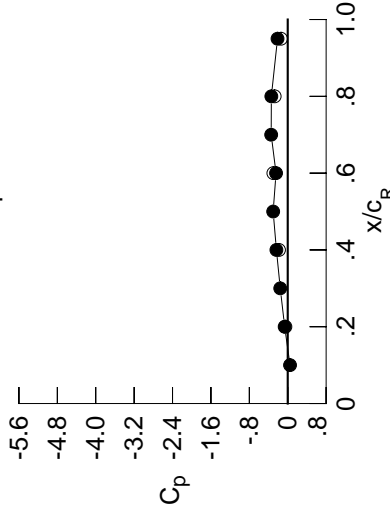

x/c_R	starb'd C_p	port C_p
0.10	0.0479	*****
0.20	-0.0637	-0.0486
0.30	-0.1557	*****
0.40	-0.2357	-0.1814
0.50	-0.3036	*****
0.60	-0.2435	-0.2990
0.70	-0.3445	*****
0.80	-0.3413	-0.2718
0.90	*****	*****
0.95	-0.2129	-0.1400

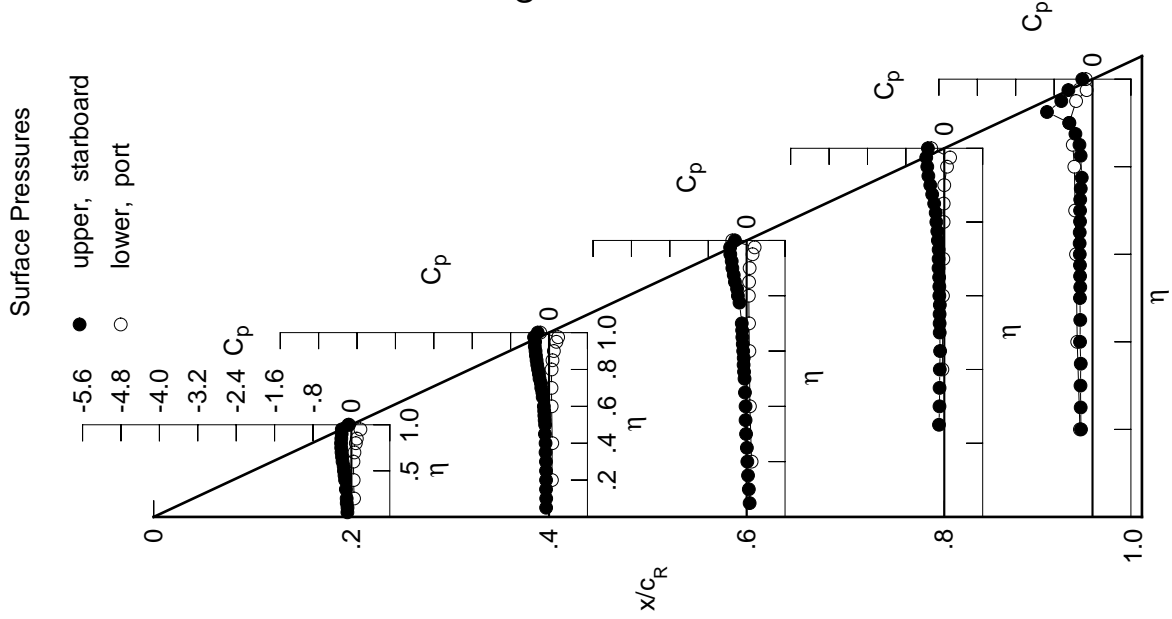

Table C1. Continued.

η	x/c_R	$C_{p,u}$	x/c_R	$C_{p,u}$	x/c_R	$C_{p,u}$	x/c_R	$C_{p,u}$	x/c_R	$C_{p,u}$
0.050	0.2	-0.1026	0.4	-0.0726	0.6	0.0571	0.8	0.0571	0.95	0.0571
0.100		-0.1011		-0.0698		0.0341		0.0341		0.0341
0.150		-0.1105		-0.0704		0.0250		0.0250		0.0250
0.200		-0.1158		-0.0758		0.0027		0.0027		0.0027
0.250		0.2379		-0.0772		-0.0026		-0.1106		-0.2379
0.300		-0.1309		-0.0796		-0.0253		-0.1097		-0.2402
0.350		0.2487		-0.0841		-0.0321		-0.1023		-0.2387
0.400		-0.1559		-0.0882		-0.0329		-0.1007		-0.2506
0.450		-0.1643		-0.1015		-0.0456		-0.0907		-0.2467
0.500		-0.1796		-0.0999		-0.0579		-0.1016		-0.2546
0.525		0.2485		-0.1099		-0.0664		-0.1047		-0.2485
0.550		-0.1842		-0.1142		-0.0733		-0.1062		-0.2481
0.575		0.2481		-0.1222		-0.0773		-0.1041		-0.2495
0.600		-0.2135		-0.1267		-0.0883		-0.1129		-0.2521
0.625		0.2600		0.2600		-0.0964		-0.1144		-0.2600
0.650		-0.2278		-0.1528		-0.1052		-0.1171		-0.2538
0.675		0.2538		-0.1705		-0.1133		-0.1356		-0.2470
0.700		-0.2445		-0.1844		-0.1204		-0.1288		-0.2447
0.725		0.2447		-0.2010		0.2453		-0.1342		-0.2453
0.750		-0.2521		-0.2320		0.2371		-0.1489		-0.2371
0.775		0.2371		-0.2419		-0.1736		-0.1652		-0.2147
0.800		-0.2621		-0.2749		-0.2089		-0.1892		0.2621
0.825		0.1892		-0.2901		-0.2384		-0.1983		-0.2280
0.850		-0.2624		-0.3126		-0.2848		-0.2426		-0.2528
0.875		0.2528		-0.3301		-0.3213		-0.2892		-0.3339
0.900		-0.2659		-0.3463		-0.3571		-0.3358		-0.4730
0.925		0.4730		-0.3738		-0.3866		-0.3965		-0.9535
0.950		-0.2817		-0.3837		-0.4314		-0.4319		-0.6819
0.975		0.6819		-0.4322		-0.4645		-0.4845		-0.5546
1.000		-0.2103		-0.4702		-0.4838		-0.6317		-0.3745
		0.3745		$C_{p,l}$		$C_{p,l}$		$C_{p,l}$		$C_{p,l}$
-0.200		0.0723		0.0763		0.1165		0.1165		-0.2721
-0.400		0.0688		0.0895		0.0824		-0.0341		-0.3230
-0.600		0.0726		0.0753		0.0756		-0.0109		-0.3531
-0.700		0.0939		0.0754		0.0708		-0.0085		-0.3731
-0.800		0.1246		0.0849		0.0715		0.0040		-0.3915
-0.850		0.1439		0.1055		0.0782		0.0096		-0.4164
-0.900		0.1347		0.1347		0.0961		0.0285		-0.4777
-0.950		0.2071		0.1775		0.1520		0.0874		-0.3088
-0.975		0.1964		0.1964		0.1850		0.1447		-0.0888
-1.000		-0.1909		-0.4093		-0.5890		-0.5433		-0.2789

Medium Radius L.E.
 Run No. = 3, Point No. = 43
 $C_N = 0.160$, $C_M = -0.0189$
 $\alpha = 5.2^\circ$, $M_\infty = 0.400$
 $R_{mac} = 6.0 \times 10^6$

Leading Edge Pressures

- starboard
- port

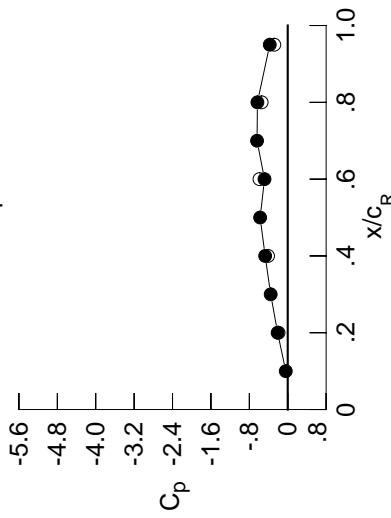

x/c_R	starb'd C_p	port C_p
0.10	-0.0407	0.0407
0.20	-0.2103	0.2103
0.30	-0.3551	0.3551
0.40	-0.4702	0.4702
0.50	-0.5748	0.5748
0.60	-0.4838	0.4838
0.70	-0.6391	0.6391
0.80	-0.6317	0.6317
0.90	-0.5433	0.5433
0.95	-0.3745	0.3745

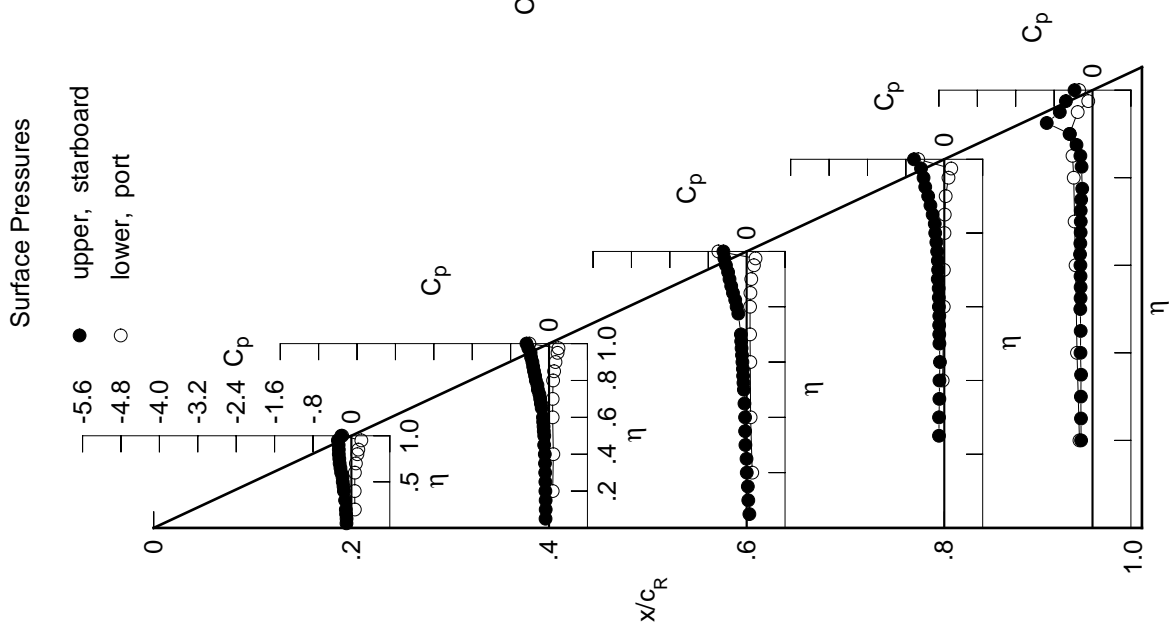

Table C1. Continued.

η	x/c_R .2	x/c_R .4	x/c_R .6	x/c_R .8	x/c_R .95
	$C_{p,u}$	$C_{p,u}$	$C_{p,u}$	$C_{p,u}$	$C_{p,u}$
0.050	-0.1149	-0.0924	0.0434	*****	*****
0.100	-0.1190	-0.0824	0.0285	*****	*****
0.150	-0.1310	-0.0836	0.0121	*****	*****
0.200	-0.1363	-0.0881	-0.0030	*****	-0.2386
0.250	*****	-0.0920	-0.0157	-0.1207	-0.2411
0.300	-0.1506	-0.0956	-0.0365	-0.1128	-0.2401
0.350	*****	-0.0991	-0.0413	-0.1094	-0.2393
0.400	-0.1757	-0.1059	-0.0509	-0.1050	-0.2445
0.450	-0.1945	-0.1139	-0.0578	-0.0999	-0.2487
0.500	-0.2028	-0.1211	-0.0720	-0.1098	-0.2496
0.525	*****	-0.1252	-0.0806	-0.1091	-0.2481
0.550	-0.2131	-0.1378	-0.0913	-0.1140	-0.2436
0.575	*****	-0.1417	-0.0927	-0.1131	-0.2474
0.600	-0.2446	-0.1529	-0.1094	-0.1206	-0.2497
0.625	*****	*****	-0.1134	-0.1263	-0.2472
0.650	-0.2623	-0.1802	-0.1301	-0.1301	-0.2472
0.675	*****	-0.1961	-0.1327	-0.1504	-0.2369
0.700	-0.2813	-0.2142	-0.1454	-0.1482	-0.2337
0.725	*****	-0.2327	*****	-0.1530	-0.2333
0.750	-0.2983	-0.2694	*****	-0.1668	-0.2291
0.775	*****	-0.2823	-0.2040	-0.1871	-0.2043
0.800	-0.3140	-0.3171	-0.2445	-0.2112	*****
0.825	*****	-0.3378	-0.2722	-0.2265	-0.2070
0.850	-0.3217	-0.3717	-0.3326	-0.2730	-0.2261
0.875	*****	-0.3934	-0.3720	-0.3269	-0.3009
0.900	-0.3343	-0.4234	-0.4178	-0.3864	-0.4378
0.925	*****	-0.4523	-0.4588	-0.4543	-0.9193
0.950	-0.3732	-0.4845	-0.5224	-0.5128	-0.6889
0.975	*****	-0.5518	-0.5940	-0.6020	-0.5931
1.000	-0.3900	-0.7579	-0.7798	-0.9745	-0.5610
	$C_{p,l}$	$C_{p,l}$	$C_{p,l}$	$C_{p,l}$	$C_{p,l}$
-0.200	0.0971	0.0912	0.1254	*****	-0.2786
-0.400	0.0930	0.1032	0.0976	-0.0289	-0.3294
-0.600	0.0981	0.0954	0.0860	-0.0007	-0.3615
-0.700	0.1222	0.0978	0.0899	0.0005	-0.3825
-0.800	0.1526	0.1118	0.0941	0.0224	-0.3995
-0.850	0.1708	0.1335	0.1022	0.0301	-0.4224
-0.900	*****	0.1600	0.1218	0.0531	-0.4744
-0.950	0.2156	0.1935	0.1717	0.1112	-0.2800
-0.975	*****	0.1917	0.1843	0.1569	-0.0616
-1.000	-0.3731	-0.6867	-0.9349	-0.8816	-0.4554

Medium Radius L.E.
 Run No. = 3, Point No. = 44
 $C_N = 0.199$, $C_M = -0.0266$
 $\alpha = 6.2^\circ$, $M_\infty = 0.400$
 $R_{mac} = 6.0 \times 10^6$

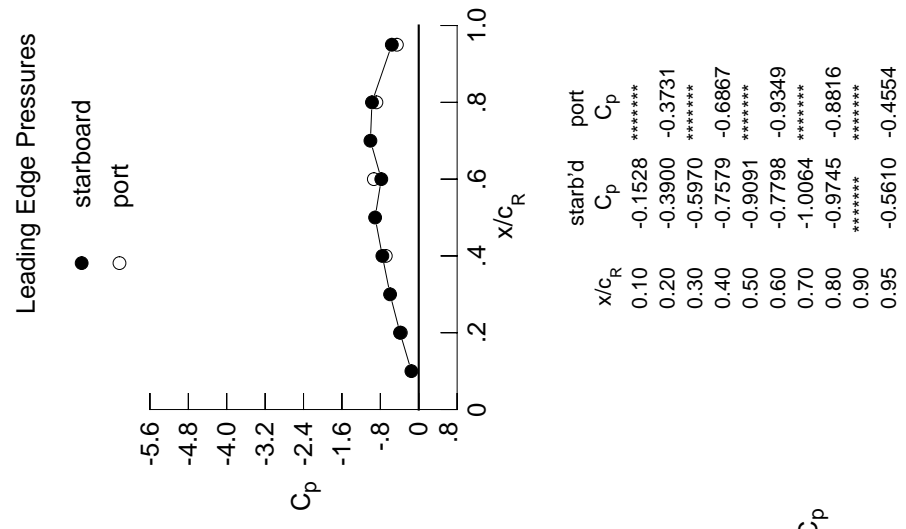
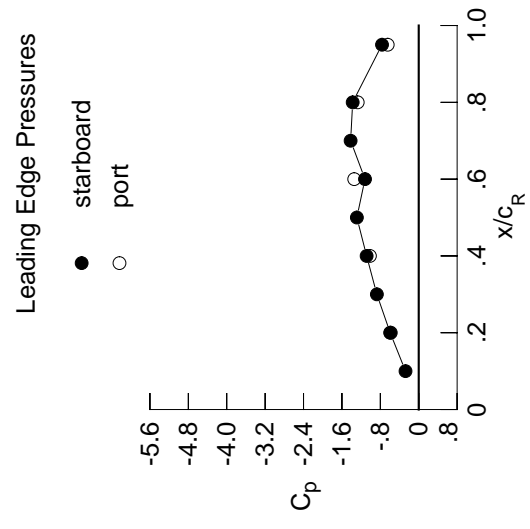

Table C1. Continued.

η	x/C_R	x/C_R	x/C_R	x/C_R	x/C_R	x/C_R	x/C_R
	$C_{p,u}$	$C_{p,u}$	$C_{p,u}$	$C_{p,u}$	$C_{p,u}$	$C_{p,i}$	$C_{p,i}$
0.050	-0.1359	-0.1013	0.0403	*****	*****	0.1168	0.1402
0.100	-0.1336	-0.0958	0.0178	*****	*****	0.1152	0.1090
0.150	-0.1469	-0.0965	0.0058	*****	*****	0.1249	0.1172
0.200	-0.1528	-0.0971	-0.0102	*****	-0.2380	0.1495	0.1219
0.250	*****	-0.1043	-0.0212	-0.1225	-0.2336	0.1782	0.1378
0.300	-0.1681	-0.1060	-0.0433	-0.1139	-0.2391	0.1923	0.1592
0.350	*****	-0.1122	-0.0480	-0.1096	-0.2371	*****	0.1837
0.400	-0.1967	-0.1209	-0.0577	-0.1076	-0.2480	0.2188	0.2031
0.450	-0.2108	-0.1357	-0.0694	-0.1080	-0.2497	*****	0.1761
0.500	-0.2276	-0.1339	-0.0850	-0.1154	-0.2521	-0.5828	-1.0172
0.525	*****	-0.1479	-0.0930	-0.1166	-0.2480	0.1761	0.1754
0.550	-0.2399	-0.1542	-0.1070	-0.1222	-0.2477	-0.5828	-1.0172
0.575	*****	-0.1631	-0.1067	-0.1246	-0.2521	0.1761	0.1754
0.600	-0.2738	-0.1751	-0.1272	-0.1294	-0.2476	0.1761	0.1754
0.625	*****	*****	-0.1293	-0.1383	-0.2548	0.1761	0.1754
0.650	-0.2932	-0.2044	-0.1495	-0.1455	-0.2521	0.1761	0.1754
0.675	*****	-0.2234	-0.1520	-0.1636	-0.2390	0.1761	0.1754
0.700	-0.3181	-0.2411	-0.1704	-0.1672	-0.2354	0.1761	0.1754
0.725	*****	-0.2592	*****	-0.1690	-0.2345	0.1761	0.1754
0.750	-0.3374	-0.3032	*****	-0.1927	-0.2261	0.1761	0.1754
0.775	*****	-0.3198	-0.2325	-0.2124	-0.1991	0.1761	0.1754
0.800	-0.3613	-0.3576	-0.2779	-0.2346	*****	0.1761	0.1754
0.825	*****	-0.3833	-0.3050	-0.2532	-0.1778	0.1761	0.1754
0.850	-0.3805	-0.4218	-0.3684	-0.2971	-0.1966	0.1761	0.1754
0.875	*****	-0.4582	-0.4186	-0.3577	-0.2532	0.1761	0.1754
0.900	-0.4059	-0.4926	-0.4798	-0.4251	-0.3823	0.1761	0.1754
0.925	*****	-0.5380	-0.5345	-0.5073	-0.8348	0.1761	0.1754
0.950	-0.4636	-0.5846	-0.6197	-0.5927	-0.6631	0.1761	0.1754
0.975	*****	-0.6887	-0.7315	-0.7144	-0.6122	0.1761	0.1754
1.000	-0.5951	-1.0854	-1.1195	-1.3762	-0.7648	0.1761	0.1754
$C_{p,i}$	$C_{p,i}$	$C_{p,i}$	$C_{p,i}$	$C_{p,i}$	$C_{p,i}$	$C_{p,i}$	$C_{p,i}$
-0.200	0.1168	0.1089	0.1402	*****	-0.2768	0.1761	0.1754
-0.400	0.1152	0.1250	0.1090	-0.0140	-0.3317	0.1761	0.1754
-0.600	0.1249	0.1172	0.1062	0.0074	-0.3634	0.1761	0.1754
-0.700	0.1495	0.1219	0.1080	0.0184	-0.3947	0.1761	0.1754
-0.800	0.1782	0.1378	0.1152	0.0345	-0.4105	0.1761	0.1754
-0.850	0.1923	0.1592	0.1295	0.0502	-0.4275	0.1761	0.1754
-0.900	*****	0.1837	0.1480	0.0760	-0.4678	0.1761	0.1754
-0.950	0.2188	0.2031	0.1877	0.1307	-0.2541	0.1761	0.1754
-0.975	*****	0.1761	0.1754	0.1610	-0.0405	0.1761	0.1754
-1.000	-0.5828	-1.0172	-1.3436	-1.2709	-0.6468	0.1761	0.1754

Medium Radius L.E.
 Run No. = 3, Point No. = 45
 $C_N = 0.234$, $C_m = -0.0318$
 $\alpha = 7.3^\circ$, $M_\infty = 0.400$
 $R_{mac} = 5.9 \times 10^6$



Leading Edge Pressures

x/C_R	starb'd C_p	port C_p
0.10	-0.2752	*****
0.20	-0.5951	-0.5828
0.30	-0.8723	*****
0.40	-1.0854	-1.0172
0.50	-1.2891	*****
0.60	-1.1195	-1.3436
0.70	-1.4188	*****
0.80	-1.3762	-1.2709
0.90	*****	*****
0.95	-0.7648	-0.6468

Table C1. Continued.

η	x/c_R	$C_{p,u}$	x/c_R	$C_{p,u}$	x/c_R	$C_{p,u}$	x/c_R	$C_{p,u}$	x/c_R	$C_{p,u}$
0.050	0.2	-0.1526	0.4	-0.1072	0.6	0.0360	0.8	0.0360	0.95	0.0360
0.100		-0.1516		-0.1067		0.0077		0.0077		0.0077
0.150		-0.1625		-0.1084		0.0020		0.0020		0.0020
0.200		-0.1663		-0.1123		-0.0199		-0.0199		-0.0199
0.250		0.2323		-0.1149		-0.0268		-0.1274		-0.2329
0.300		-0.1878		-0.1207		-0.0527		-0.1244		-0.2383
0.350		0.2360		-0.1297		-0.0593		-0.1153		-0.2360
0.400		-0.2169		-0.1378		-0.0659		-0.1152		-0.2442
0.450		-0.2323		-0.1531		-0.0822		-0.1121		-0.2495
0.500		-0.2509		-0.1590		-0.0994		-0.1251		-0.2604
0.525		0.2609		-0.1673		-0.1101		-0.1238		-0.2609
0.550		-0.2660		-0.1782		-0.1216		-0.1288		-0.2649
0.575		0.2735		-0.1866		-0.1245		-0.1287		-0.2735
0.600		-0.3043		-0.2024		-0.1469		-0.1418		-0.2776
0.625		0.2854		0.2854		-0.1547		-0.1505		-0.2854
0.650		-0.3286		-0.2293		-0.1755		-0.1577		-0.2864
0.675		0.2890		-0.2512		-0.1883		-0.1850		-0.2890
0.700		-0.3578		-0.2693		-0.2006		-0.1984		-0.2914
0.725		0.3011		-0.2944		0.2052		-0.3011		-0.3011
0.750		-0.3846		-0.3329		0.2392		-0.2929		-0.2929
0.775		0.2486		-0.4141		-0.4001		-0.3066		-0.2787
0.800		0.2043		0.2043		-0.4327		-0.3399		-0.2922
0.825		-0.4430		-0.4784		-0.4057		-0.3241		-0.1982
0.850		0.2155		-0.5188		-0.4701		-0.3804		-0.2155
0.875		-0.2968		-0.4822		-0.5685		-0.5383		-0.4529
0.900		0.6605		0.6605		-0.6275		-0.6099		-0.5564
0.925		-0.5850		-0.5509		-0.7193		-0.6657		-0.5850
0.950		0.6107		-0.8450		-0.8785		-0.8417		-0.6107
0.975		-1.0082		-1.4684		-1.5171		-1.8505		-1.0082
1.000		0.8736		0.8736		0.8736		0.8736		0.8736
-0.200		0.1422		0.1297		0.1599		0.1599		-0.2806
-0.400		0.1391		0.1447		0.1262		-0.0020		-0.3243
-0.600		0.1499		0.1388		0.1248		0.0254		-0.3579
-0.700		0.1766		0.1463		0.1273		0.0307		-0.3916
-0.800		0.2034		0.1640		0.1367		0.0520		-0.4154
-0.850		0.2143		0.1852		0.1530		0.0704		-0.4302
-0.900		0.2130		0.2024		0.1675		0.0984		-0.4583
-0.950		0.2130		0.2051		0.1938		0.1470		-0.2265
-0.975		0.2265		0.1468		0.1576		0.1544		-0.0234
-1.000		-0.8306		-1.4060		-1.8340		-1.7376		-0.8736

Medium Radius L.E.
 Run No. = 3, Point No. = 46
 $C_N = 0.268$, $C_m = -0.0346$
 $\alpha = 8.3^\circ$, $M_\infty = 0.400$
 $R_{mac} = 6.0 \times 10^6$

Leading Edge Pressures

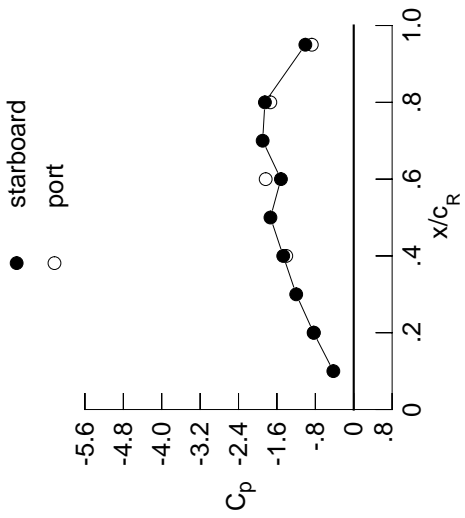

x/c_R	starb'd C_p	port C_p
0.10	-0.4245	0.0000
0.20	-0.8360	-0.8306
0.30	-1.1982	0.0000
0.40	-1.4684	-1.4060
0.50	-1.7349	0.0000
0.60	-1.5171	-1.8340
0.70	-1.8974	0.0000
0.80	-1.8505	-1.7376
0.90	0.0000	0.0000
0.95	-1.0082	-0.8736

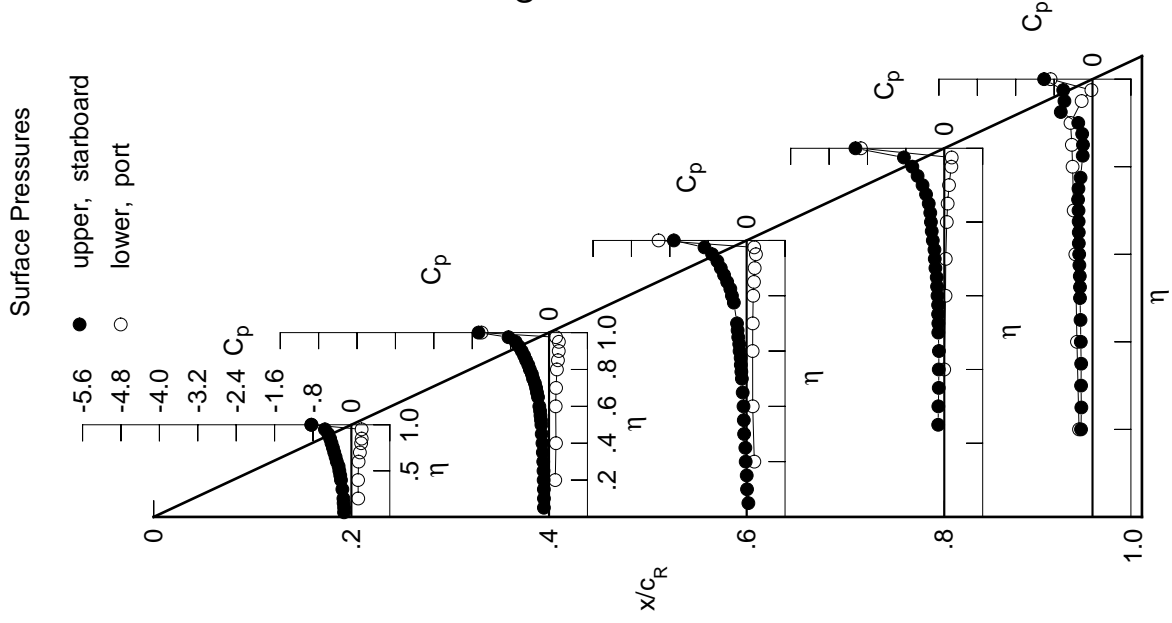
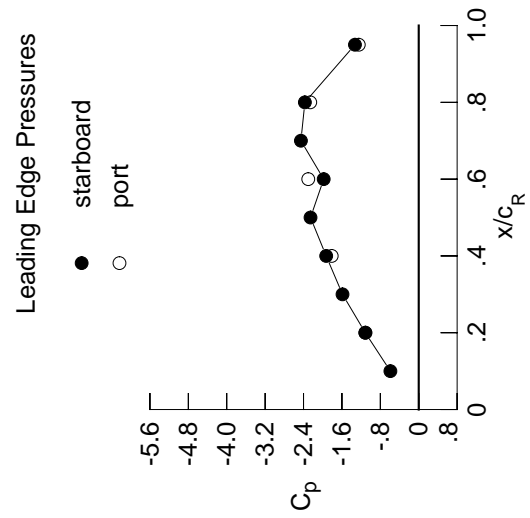

Table C1. Continued.

η	x/c_R	x/c_R	x/c_R	x/c_R	x/c_R	x/c_R	x/c_R
	$C_{p,u}$	$C_{p,u}$	$C_{p,u}$	$C_{p,u}$	$C_{p,u}$	$C_{p,i}$	$C_{p,i}$
0.050	-0.1609	-0.1227	0.0233	*****	*****	*****	*****
0.100	-0.1671	-0.1194	0.0041	*****	*****	*****	*****
0.150	-0.1827	-0.1211	-0.0129	*****	*****	*****	*****
0.200	-0.1887	-0.1297	-0.0308	*****	*****	-0.2505	*****
0.250	*****	-0.1319	-0.0399	-0.1360	-0.2410	*****	*****
0.300	-0.2083	-0.1369	-0.0604	-0.1312	-0.2390	*****	*****
0.350	*****	-0.1482	-0.0695	-0.1265	-0.2407	*****	*****
0.400	-0.2390	-0.1570	-0.0819	-0.1275	-0.2449	*****	*****
0.450	-0.2572	-0.1765	-0.0960	-0.1242	-0.2511	*****	*****
0.500	-0.2778	-0.1855	-0.1132	-0.1358	-0.2644	*****	*****
0.525	*****	-0.1955	-0.1250	-0.1287	-0.2703	*****	*****
0.550	-0.2937	-0.2092	-0.1448	-0.1364	-0.2802	*****	*****
0.575	*****	-0.2176	-0.1458	-0.1283	-0.2941	*****	*****
0.600	-0.3359	-0.2317	-0.1725	-0.1406	-0.3114	*****	*****
0.625	*****	*****	-0.1894	-0.1459	-0.3201	*****	*****
0.650	-0.3650	-0.2660	-0.2218	-0.1498	-0.3249	*****	*****
0.675	*****	-0.2848	-0.2360	-0.1950	-0.3191	*****	*****
0.700	-0.3994	-0.3049	-0.2668	-0.2434	-0.3553	*****	*****
0.725	*****	-0.3286	*****	-0.2959	-0.4211	*****	*****
0.750	-0.4331	-0.3713	*****	-0.3612	-0.5204	*****	*****
0.775	*****	-0.4004	-0.3293	-0.4207	-0.5151	*****	*****
0.800	-0.4725	-0.4440	-0.3644	-0.4135	*****	*****	*****
0.825	*****	-0.4880	-0.3790	-0.3976	-0.3157	*****	*****
0.850	-0.5098	-0.5326	-0.4390	-0.4109	-0.2629	*****	*****
0.875	*****	-0.5935	-0.5019	-0.4241	-0.2477	*****	*****
0.900	-0.5653	-0.6503	-0.5894	-0.4544	-0.2617	*****	*****
0.925	*****	-0.7250	-0.6800	-0.5497	-0.3043	*****	*****
0.950	-0.6674	-0.8171	-0.8218	-0.7020	-0.4720	*****	*****
0.975	*****	-1.0112	-1.0318	-0.9447	-0.6321	*****	*****
1.000	-1.1132	-1.9283	-1.9799	-2.3718	-1.3285	*****	*****
-0.200	$C_{p,i}$	$C_{p,i}$	$C_{p,i}$	$C_{p,i}$	$C_{p,i}$	$C_{p,i}$	$C_{p,i}$
-0.400	0.1650	0.1461	0.1724	*****	-0.2845	*****	*****
-0.600	0.1639	0.1642	0.1417	0.0104	-0.3169	*****	*****
-0.700	0.1712	0.1582	0.1425	0.0439	-0.3158	*****	*****
-0.800	0.1970	0.1688	0.1483	0.0529	-0.3277	*****	*****
-0.850	0.2213	0.1879	0.1599	0.0801	-0.3638	*****	*****
-0.900	0.2294	0.2039	0.1737	0.0931	-0.3873	*****	*****
-0.950	*****	0.2142	0.1868	0.1217	-0.4166	*****	*****
-0.975	0.1985	0.1977	0.1927	0.1585	-0.1816	*****	*****
-1.000	*****	0.1043	0.1255	0.1406	-0.0006	*****	*****
		-1.1093	-1.8128	-2.3013	-2.2599	-1.2488	*****

Medium Radius L.E.
 Run No. = 3, Point No. = 47
 $C_N = 0.318$, $C_m = -0.0465$
 $\alpha = 9.3^\circ$, $M_\infty = 0.400$
 $R_{mac} = 5.9 \times 10^6$



x/c_R	starb'd C_p	port C_p
0.10	-0.5904	*****
0.20	-1.1132	-1.1093
0.30	-1.5879	*****
0.40	-1.9283	-1.8128
0.50	-2.2545	*****
0.60	-1.9799	-2.3013
0.70	-2.4546	*****
0.80	-2.3718	-2.2599
0.90	*****	*****
0.95	-1.3285	-1.2488

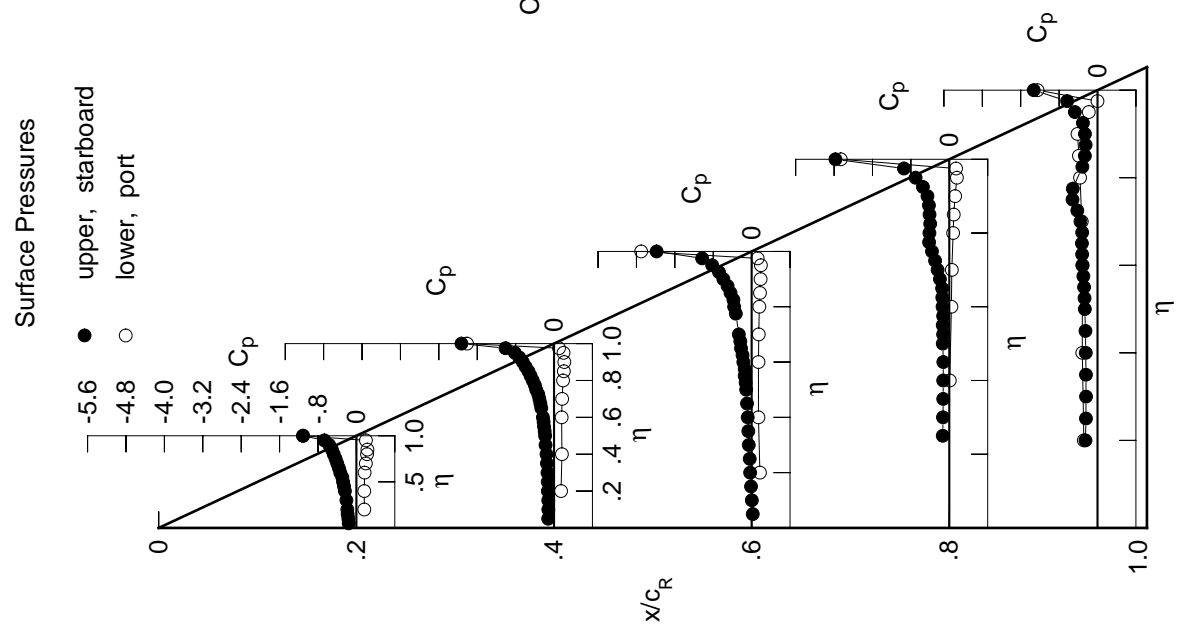
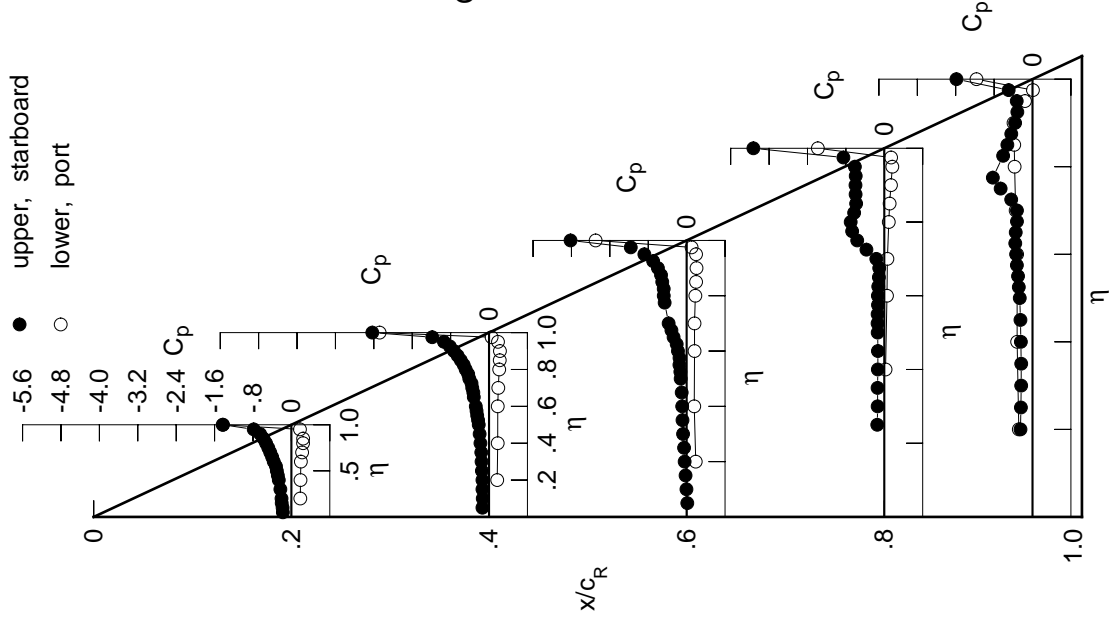

Table C1. Continued.

η	x/c_R	$C_{p,u}$	x/c_R	$C_{p,u}$	x/c_R	$C_{p,u}$	x/c_R	$C_{p,u}$	x/c_R	$C_{p,u}$
0.050	0.1774	-0.1380	0.0137	*****	0.1855	0.1702	0.1898	*****	-0.2853	
0.100	-0.1832	-0.1308	-0.0039	*****	0.1895	0.1807	0.1584	0.0264	-0.3203	
0.150	-0.2017	-0.1374	-0.0225	*****	0.1979	0.1818	0.1645	0.0560	-0.3209	
0.200	-0.2057	-0.1379	-0.0413	*****	0.2230	0.1925	0.1640	0.0647	-0.3514	
0.250	*****	-0.1487	-0.0536	-0.1465	-0.2431	0.2119	0.1813	0.0938	-0.3726	
0.300	-0.2295	-0.1559	-0.0742	-0.1383	0.2450	0.2233	0.1967	0.1114	-0.3806	
0.350	*****	-0.1612	-0.0866	-0.1401	*****	0.2275	0.2056	0.1393	-0.3956	
0.400	-0.2626	-0.1794	-0.0928	-0.1341	-0.2426	0.1784	0.1866	0.1962	-0.1569	
0.450	-0.2826	-0.1956	-0.1032	-0.1329	-0.2512	*****	0.0535	0.1032	0.1412	
0.500	-0.3035	-0.2144	-0.1248	-0.1376	-0.2655	-1.4317	-2.2794	-1.8963	-1.3842	
0.525	*****	-0.2278	-0.1311	-0.1399	-0.2854	-1.000	-1.4317	-2.2794	-1.8963	
0.550	-0.3218	-0.2461	-0.1504	-0.1392	-0.3016	0.1784	0.1866	0.1962	-0.1569	
0.575	*****	-0.2598	-0.1490	-0.1311	-0.3254	0.1784	0.1866	0.1962	-0.1569	
0.600	-0.3675	-0.2761	-0.1810	-0.1340	-0.3415	0.1784	0.1866	0.1962	-0.1569	
0.625	*****	*****	-0.2070	-0.1253	-0.3595	0.1784	0.1866	0.1962	-0.1569	
0.650	-0.4011	-0.3178	-0.2717	-0.1129	-0.3494	0.1784	0.1866	0.1962	-0.1569	
0.675	*****	-0.3272	-0.3167	-0.1057	-0.3237	0.1784	0.1866	0.1962	-0.1569	
0.700	-0.4410	-0.3500	-0.3752	-0.1661	-0.3238	0.1784	0.1866	0.1962	-0.1569	
0.725	*****	-0.3649	*****	-0.3721	-0.4438	0.1784	0.1866	0.1962	-0.1569	
0.750	-0.4819	-0.4113	*****	-0.5642	-0.6641	0.1784	0.1866	0.1962	-0.1569	
0.775	*****	-0.4346	-0.4585	-0.6696	-0.8266	0.1784	0.1866	0.1962	-0.1569	
0.800	-0.5282	-0.4861	-0.4768	-0.6997	*****	0.1784	0.1866	0.1962	-0.1569	
0.825	*****	-0.5284	-0.4778	-0.6281	-0.6119	0.1784	0.1866	0.1962	-0.1569	
0.850	-0.5800	-0.5886	-0.5078	-0.5861	-0.5240	0.1784	0.1866	0.1962	-0.1569	
0.875	*****	-0.6547	-0.5339	-0.5975	-0.4422	0.1784	0.1866	0.1962	-0.1569	
0.900	-0.6506	-0.7311	-0.5987	-0.6001	-0.3622	0.1784	0.1866	0.1962	-0.1569	
0.925	*****	-0.8164	-0.6972	-0.5955	-0.3162	0.1784	0.1866	0.1962	-0.1569	
0.950	-0.7852	-0.9391	-0.8808	-0.6127	-0.3287	0.1784	0.1866	0.1962	-0.1569	
0.975	*****	-1.1830	-1.1638	-0.8518	-0.4965	0.1784	0.1866	0.1962	-0.1569	
1.000	-1.4243	-2.4324	-2.4188	-2.7276	-1.5847	0.1784	0.1866	0.1962	-0.1569	

Surface Pressures



Medium Radius L.E.
 Run No. = 3, Point No. = 48
 $C_N = 0.368$, $C_m = -0.0568$
 $\alpha = 10.3^\circ$, $M_\infty = 0.400$
 $R_{mac} = 6.0 \times 10^6$

Leading Edge Pressures

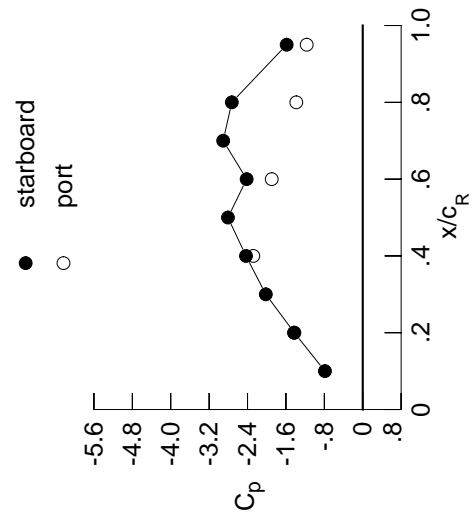

x/c_R	starb'd C_p	port C_p
0.10	-0.7868	*****
0.20	-1.4243	-1.4317
0.30	-2.0189	*****
0.40	-2.4324	-2.2794
0.50	-2.8079	*****
0.60	-2.4188	-1.8963
0.70	-2.9071	*****
0.80	-2.7276	-1.3842
0.90	*****	*****
0.95	-1.5847	-1.1669

Table C1. Continued.

η	x/c_R	x/c_R	x/c_R	x/c_R	x/c_R	x/c_R	x/c_R
	$C_{p,u}$	$C_{p,u}$	$C_{p,u}$	$C_{p,u}$	$C_{p,u}$	$C_{p,i}$	$C_{p,i}$
0.050	-0.1948	-0.1507	0.0007	*****	*****	*****	*****
0.100	-0.2005	-0.1512	-0.0237	*****	*****	*****	*****
0.150	-0.2214	-0.1542	-0.0399	*****	*****	*****	*****
0.200	-0.2306	-0.1569	-0.0548	*****	*****	*****	*****
0.250	*****	-0.1648	-0.0676	-0.1557	-0.2317	-0.2486	-0.2486
0.300	-0.2535	-0.1682	-0.0902	-0.1485	-0.2298	-0.2317	-0.2317
0.350	*****	-0.1766	-0.1050	-0.1463	-0.2218	-0.2298	-0.2298
0.400	-0.2895	-0.2005	-0.1114	-0.1347	-0.2738	-0.2218	-0.2218
0.450	-0.3103	-0.2269	-0.1158	-0.1311	-0.3069	-0.2738	-0.2738
0.500	-0.3351	-0.2539	-0.1277	-0.1519	-0.3291	-0.3069	-0.3069
0.525	*****	-0.2704	-0.1384	-0.1824	-0.3280	-0.3291	-0.3291
0.550	-0.3538	-0.3006	-0.1724	-0.2278	-0.2913	-0.3280	-0.3280
0.575	*****	-0.3166	-0.2119	-0.2645	-0.2638	-0.2913	-0.2913
0.600	-0.4032	-0.3518	-0.3015	-0.2642	-0.2585	-0.2638	-0.2638
0.625	*****	*****	-0.3746	-0.2311	-0.2703	-0.2585	-0.2585
0.650	-0.4404	-0.4140	-0.4326	-0.2154	-0.2857	-0.2703	-0.2703
0.675	*****	-0.4231	-0.3768	-0.2203	-0.2998	-0.2857	-0.2857
0.700	-0.4856	-0.4307	-0.3305	-0.2139	-0.3324	-0.2998	-0.2998
0.725	*****	-0.4390	*****	-0.2055	-0.3863	-0.3324	-0.3324
0.750	-0.5308	-0.4729	*****	-0.2221	-0.4472	-0.3863	-0.3863
0.775	*****	-0.4854	-0.3941	-0.2727	-0.4821	-0.4472	-0.4472
0.800	-0.5858	-0.5320	-0.4347	-0.4386	*****	-0.4821	-0.4821
0.825	*****	-0.5732	-0.4484	-0.7037	-0.4879	*****	*****
0.850	-0.6485	-0.6319	-0.5109	-0.8510	-0.4453	-0.4879	-0.4879
0.875	*****	-0.6958	-0.5892	-0.7990	-0.4555	-0.4453	-0.4453
0.900	-0.7359	-0.7794	-0.8585	-0.7473	-0.5150	-0.4555	-0.4555
0.925	*****	-0.8716	-1.3139	-0.7935	-0.6233	-0.5150	-0.5150
0.950	-0.8849	-1.0537	-1.4904	-1.0117	-0.5948	-0.6233	-0.6233
0.975	*****	-1.6623	-1.4103	-0.9672	-0.5299	-0.5948	-0.5948
1.000	-1.7341	-2.3031	-1.3282	-1.0592	-0.6783	-0.5299	-0.5299
-0.200	$C_{p,i}$	$C_{p,i}$	$C_{p,i}$	$C_{p,i}$	$C_{p,i}$	$C_{p,i}$	$C_{p,i}$
-0.400	0.2036	0.1928	0.2017	*****	-0.2878	0.2017	0.2017
-0.600	0.2118	0.2049	0.1792	0.0354	-0.3228	0.1792	0.1792
-0.700	0.2234	0.2048	0.1775	0.0684	-0.3487	0.1775	0.1775
-0.800	0.2460	0.2141	0.1902	0.0768	-0.3570	0.1902	0.1902
-0.850	0.2615	0.2354	0.2024	0.1082	-0.3707	0.2024	0.2024
-0.900	0.2585	0.2444	0.2163	0.1265	-0.3815	0.2163	0.2163
-0.950	*****	0.2382	0.2225	0.1548	-0.3953	0.2225	0.2225
-0.975	*****	0.1531	0.1737	0.2044	0.1763	0.1737	0.1737
-1.000	*****	0.0032	0.1016	0.1463	0.0052	0.1016	0.1016
		-1.7814	-2.4199	-1.3712	-0.9503	-0.6077	-0.6077

Medium Radius L.E.
 Run No. = 3, Point No. = 49
 $C_N = 0.409$, $C_M = -0.0572$
 $\alpha = 11.3^\circ$, $M_\infty = 0.400$
 $R_{mac} = 6.0 \times 10^6$

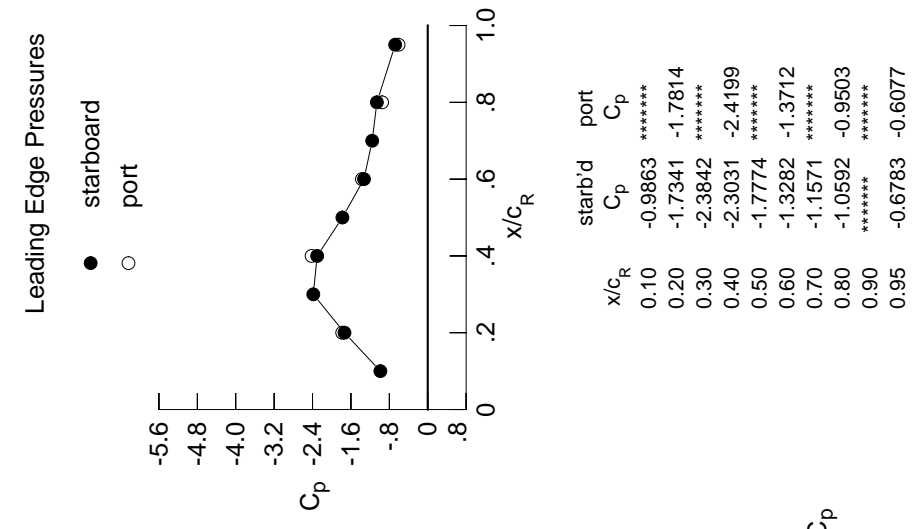

x/c_R	starb'd C_p	port C_p
0.10	-0.9863	*****
0.20	-1.7341	-1.7814
0.30	-2.3842	*****
0.40	-2.3031	-2.4199
0.50	-1.7774	*****
0.60	-1.3282	-1.3712
0.70	-1.1571	*****
0.80	-1.0592	-0.9503
0.90	*****	*****
0.95	-0.6783	-0.6077

Table C1. Continued.

η	x/c_R	x/c_R	x/c_R	x/c_R	x/c_R	x/c_R	x/c_R
	$C_{p,u}$	$C_{p,u}$	$C_{p,u}$	$C_{p,u}$	$C_{p,u}$	$C_{p,u}$	$C_{p,u}$
0.050	-0.2147	-0.1741	-0.0202	*****	*****	*****	*****
0.100	-0.2136	-0.1643	-0.0411	*****	*****	*****	*****
0.150	-0.2440	-0.1711	-0.0523	*****	*****	*****	*****
0.200	-0.2511	-0.1765	-0.0771	*****	*****	*****	-0.2660
0.250	*****	-0.1803	-0.0902	-0.1712	-0.2471	*****	*****
0.300	-0.2838	-0.1855	-0.1092	-0.1566	-0.2530	*****	*****
0.350	*****	-0.1940	-0.1200	-0.1565	-0.2751	*****	*****
0.400	-0.3245	-0.2034	-0.1220	-0.1522	-0.2965	*****	*****
0.450	-0.3448	-0.2456	-0.1522	-0.1626	-0.3109	*****	*****
0.500	-0.3673	-0.2865	-0.1842	-0.1909	-0.3149	*****	*****
0.525	*****	-0.3340	-0.2034	-0.2164	-0.3001	*****	*****
0.550	-0.3908	-0.3708	-0.2251	-0.2399	-0.2799	*****	*****
0.575	*****	-0.4126	-0.2333	-0.2522	-0.2721	*****	*****
0.600	-0.4384	-0.4422	-0.2848	-0.2476	-0.2643	*****	*****
0.625	*****	*****	-0.2959	-0.2433	-0.2832	*****	*****
0.650	-0.4812	-0.4692	-0.3666	-0.2344	-0.2885	*****	*****
0.675	*****	-0.4678	-0.4047	-0.2425	-0.3113	*****	*****
0.700	-0.5304	-0.4796	-0.4514	-0.2340	-0.3523	*****	*****
0.725	*****	-0.5102	*****	-0.2345	-0.4401	*****	*****
0.750	-0.5840	-0.5635	*****	-0.2735	-0.5591	*****	*****
0.775	*****	-0.5733	-0.4184	-0.3847	-0.6453	*****	*****
0.800	-0.6482	-0.6119	-0.4564	-0.6577	*****	*****	*****
0.825	*****	-0.6450	-0.4869	-0.9596	-0.6716	*****	*****
0.850	-0.7275	-0.6891	-0.5544	-1.1011	-0.5965	*****	*****
0.875	*****	-0.7405	-0.8235	-1.0114	-0.5341	*****	*****
0.900	-0.8308	-0.8721	-1.2361	-0.8764	-0.5040	*****	*****
0.925	*****	-1.0639	-1.5934	-0.8671	-0.4852	*****	*****
0.950	-1.0204	-1.2901	-1.5731	-0.9387	-0.4136	*****	*****
0.975	*****	-1.5819	-1.4249	-0.9108	-0.3707	*****	*****
1.000	-2.1043	-2.7146	-1.3054	-0.9407	-0.4708	*****	*****
-0.200	0.2323	0.2152	0.2222	*****	-0.2835	*****	*****
-0.400	0.2375	0.2295	0.1961	0.0474	-0.3233	*****	*****
-0.600	0.2482	0.2305	0.1993	0.0816	-0.3438	*****	*****
-0.700	0.2689	0.2402	0.2075	0.0933	-0.3581	*****	*****
-0.800	0.2796	0.2594	0.2229	0.1245	-0.3790	*****	*****
-0.850	0.2659	0.2675	0.2373	0.1410	-0.3940	*****	*****
-0.900	*****	0.2528	0.2368	0.1697	-0.4011	*****	*****
-0.950	0.1187	0.1740	0.2089	0.1861	-0.1554	*****	*****
-0.975	*****	-0.0086	0.0931	0.1480	0.0067	*****	*****
-1.000	-2.1672	-1.6961	-1.1695	-0.7965	-0.4325	*****	*****

Medium Radius L.E.
 Run No. = 3, Point No. = 50
 $C_N = 0.466$, $C_m = -0.0674$
 $\alpha = 12.3^\circ$, $M_\infty = 0.400$
 $R_{mac} = 6.0 \times 10^6$

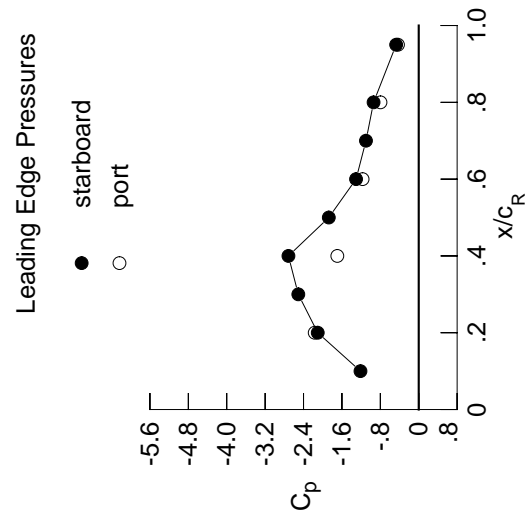

x/c_R	starb'd C_p	port C_p
0.10	-1.2139	*****
0.20	-2.1043	-2.1672
0.30	-2.5088	*****
0.40	-2.7146	-1.6961
0.50	-1.8734	*****
0.60	-1.3054	-1.1695
0.70	-1.0988	*****
0.80	-0.9407	-0.7965
0.90	*****	*****
0.95	-0.4708	-0.4325

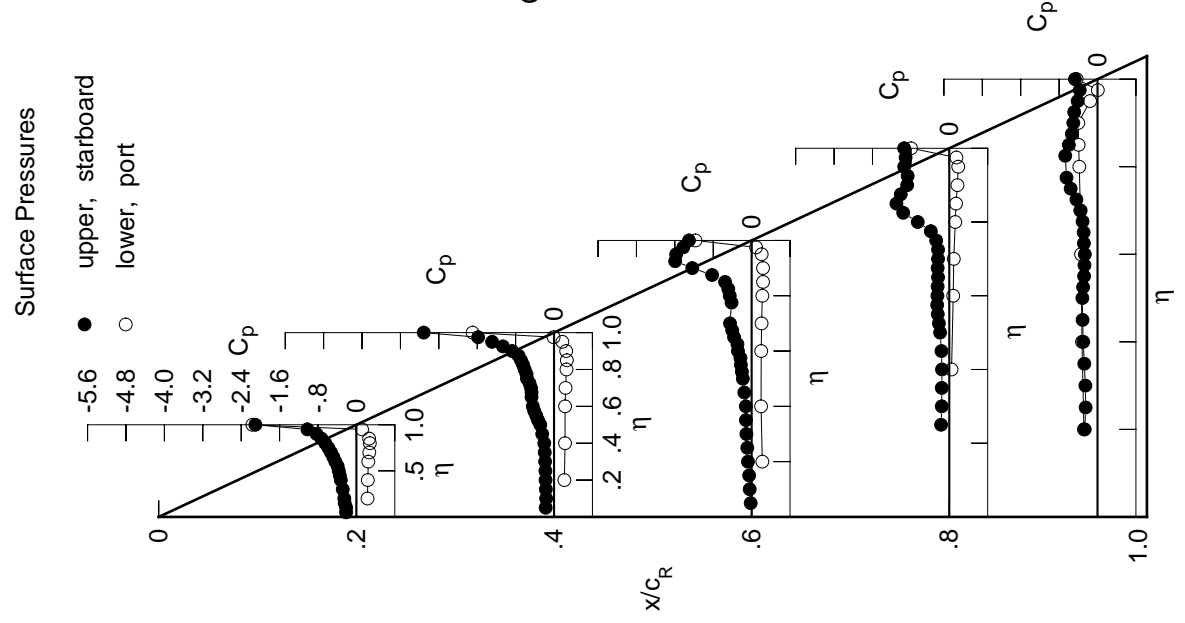
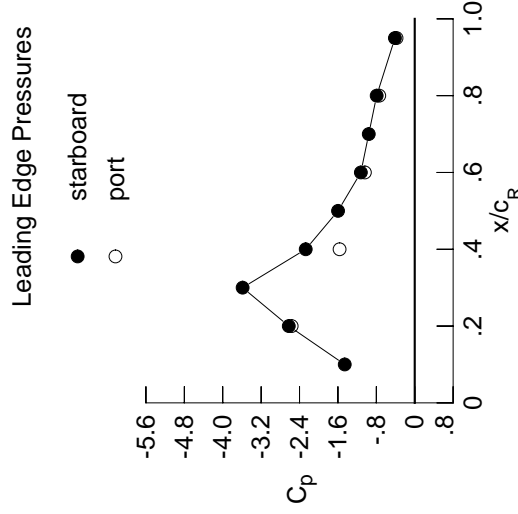

Table C1. Continued.

η	x/c_R .2	x/c_R .4	x/c_R .6	x/c_R .8	x/c_R .95
	$C_{p,u}$	$C_{p,u}$	$C_{p,u}$	$C_{p,u}$	$C_{p,u}$
0.050	-0.2285	-0.1942	-0.0349	*****	*****
0.100	-0.2299	-0.1875	-0.0578	*****	*****
0.150	-0.2636	-0.1928	-0.0763	*****	*****
0.200	-0.2757	-0.1912	-0.0964	*****	-0.2711
0.250	*****	-0.2048	-0.1103	-0.1780	-0.2519
0.300	-0.3175	-0.2029	-0.1363	-0.1670	-0.2549
0.350	*****	-0.2072	-0.1476	-0.1632	-0.2686
0.400	-0.3591	-0.2209	-0.1572	-0.1578	-0.2822
0.450	-0.3812	-0.2481	-0.1721	-0.1783	-0.2818
0.500	-0.4055	-0.2753	-0.1935	-0.2143	-0.2484
0.525	*****	-0.3141	-0.2240	-0.1987	-0.2540
0.550	-0.4308	-0.3674	-0.2845	-0.1860	-0.2670
0.575	*****	-0.4144	-0.3428	-0.1728	-0.2926
0.600	-0.4829	-0.4734	-0.3756	-0.1730	-0.3111
0.625	*****	*****	-0.3373	-0.1711	-0.3352
0.650	-0.5266	-0.6529	-0.3226	-0.1681	-0.3605
0.675	*****	-0.7393	-0.3028	-0.1820	-0.3989
0.700	-0.5741	-0.7711	-0.3081	-0.2190	-0.4983
0.725	*****	-0.7516	*****	-0.3345	-0.6339
0.750	-0.6343	-0.7476	*****	-0.5914	-0.7634
0.775	*****	-0.7398	-0.4496	-0.9427	-0.8086
0.800	-0.7103	-0.7612	-0.7490	-1.2245	*****
0.825	*****	-0.7389	-1.1767	-1.3358	-0.6424
0.850	-0.8101	-0.7145	-1.4874	-1.1747	-0.5218
0.875	*****	-0.7153	-1.5737	-0.9304	-0.4876
0.900	-0.9404	-0.7552	-1.5235	-0.8751	-0.4869
0.925	*****	-1.1008	-1.4016	-0.8423	-0.4780
0.950	-1.1972	-2.1184	-1.3167	-0.8030	-0.3879
0.975	*****	-2.1575	-1.2297	-0.7806	-0.3375
1.000	-2.6237	-2.2709	-1.1227	-0.7932	-0.4124
	$C_{p,l}$	$C_{p,l}$	$C_{p,l}$	$C_{p,l}$	$C_{p,l}$
-0.200	0.2609	0.2355	0.2368	*****	-0.2897
-0.400	0.2613	0.2503	0.2118	0.0642	-0.3359
-0.600	0.2753	0.2530	0.2196	0.0942	-0.3318
-0.700	0.2925	0.2624	0.2232	0.1058	-0.3628
-0.800	0.2925	0.2773	0.2399	0.1335	-0.3925
-0.850	0.2687	0.2841	0.2531	0.1539	-0.4007
-0.900	*****	0.2620	0.2508	0.1798	-0.3976
-0.950	0.0777	0.1640	0.2085	0.1882	-0.1463
-0.975	*****	-0.0375	0.0818	0.1416	0.0097
-1.000	-2.5640	-1.5652	-1.0384	-0.7393	-0.3794

Medium Radius L.E.
 Run No. = 3, Point No. = 51
 $C_N = 0.517$, $C_m = -0.0726$
 $\alpha = 13.3^\circ$, $M_\infty = 0.400$
 $R_{mac} = 6.0 \times 10^6$



x/c_R	starbd C_p	port C_p
0.10	-1.4583	*****
0.20	-2.6237	-2.5640
0.30	-3.5857	*****
0.40	-2.2709	-1.5652
0.50	-1.5979	*****
0.60	-1.1227	-1.0384
0.70	-0.9577	*****
0.80	-0.7932	-0.7393
0.90	*****	*****
0.95	-0.4124	-0.3794

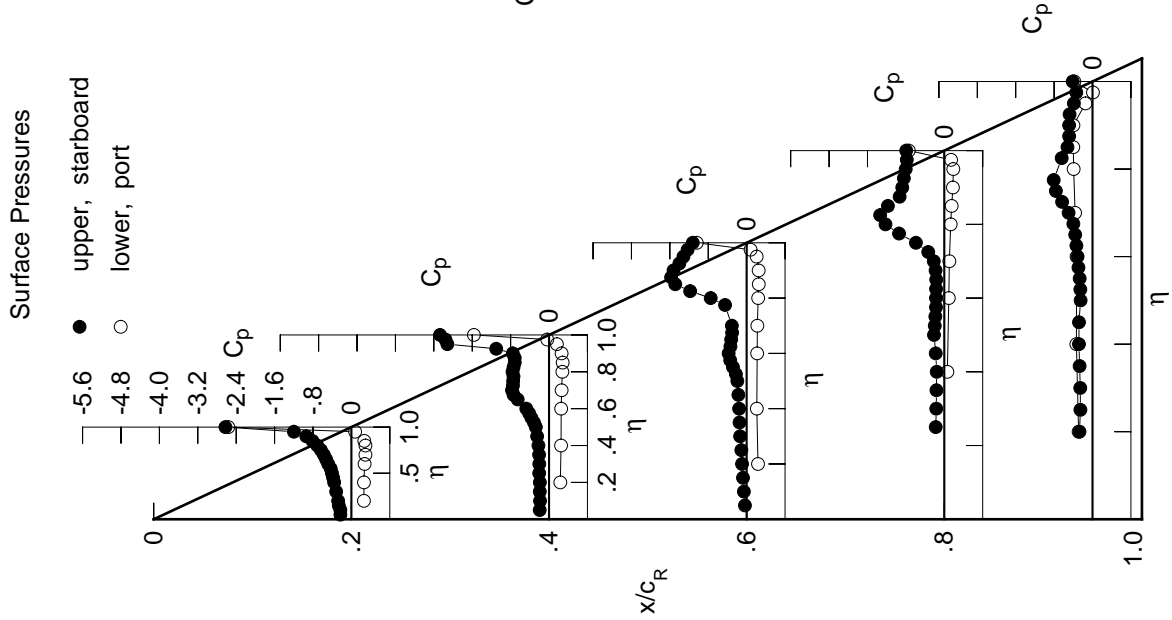
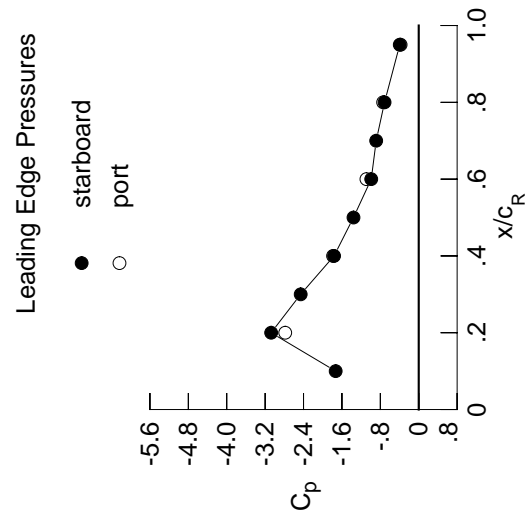

Table C1. Continued.

η	x/c_R	$C_{p,u}$	x/c_R	$C_{p,u}$	x/c_R	$C_{p,u}$	x/c_R	$C_{p,u}$	x/c_R	$C_{p,u}$
0.050	0.2	-0.2448	0.4	-0.2146	0.6	-0.0493	0.8	0.0000	0.95	0.0000
0.100	0.2	-0.2472	0.4	-0.2092	0.6	-0.0665	0.8	0.0000	0.95	0.0000
0.150	0.2	-0.2738	0.4	-0.2156	0.6	-0.0915	0.8	0.0000	0.95	0.0000
0.200	0.2	-0.3025	0.4	-0.2240	0.6	-0.1062	0.8	0.0000	0.95	0.0000
0.250	0.2	0.0000	0.4	-0.2321	0.6	-0.1211	0.8	-0.1800	0.95	-0.2739
0.300	0.2	-0.3498	0.4	-0.2254	0.6	-0.1420	0.8	-0.1703	0.95	-0.2767
0.350	0.2	0.0000	0.4	-0.2402	0.6	-0.1543	0.8	-0.1761	0.95	-0.2814
0.400	0.2	-0.4016	0.4	-0.2468	0.6	-0.1854	0.8	-0.1964	0.95	-0.2501
0.450	0.2	-0.4339	0.4	-0.2708	0.6	-0.2418	0.8	-0.1690	0.95	-0.2562
0.500	0.2	-0.4579	0.4	-0.2953	0.6	-0.2321	0.8	-0.1666	0.95	-0.2955
0.525	0.2	0.0000	0.4	-0.3533	0.6	-0.2282	0.8	-0.1528	0.95	-0.3211
0.550	0.2	-0.4731	0.4	-0.4558	0.6	-0.2239	0.8	-0.1564	0.95	-0.3399
0.575	0.2	0.0000	0.4	-0.5959	0.6	-0.2228	0.8	-0.1399	0.95	-0.3700
0.600	0.2	-0.5195	0.4	-0.6720	0.6	-0.2280	0.8	-0.1531	0.95	-0.3953
0.625	0.2	0.0000	0.4	0.0000	0.6	-0.2242	0.8	-0.1629	0.95	-0.4311
0.650	0.2	-0.5659	0.4	-0.4862	0.6	-0.2294	0.8	-0.1977	0.95	-0.4918
0.675	0.2	0.0000	0.4	-0.4715	0.6	-0.2374	0.8	-0.2941	0.95	-0.5585
0.700	0.2	-0.6196	0.4	-0.4826	0.6	-0.2738	0.8	-0.4661	0.95	-0.6573
0.725	0.2	0.0000	0.4	-0.4815	0.6	0.0000	0.8	-0.7341	0.95	-0.7430
0.750	0.2	-0.6882	0.4	-0.5098	0.6	0.0000	0.8	-1.0496	0.95	-0.7772
0.775	0.2	-0.4960	0.4	-0.4992	0.6	-1.1252	0.8	-1.2854	0.95	-0.7364
0.800	0.2	-0.7763	0.4	-0.4992	0.6	-1.5829	0.8	-1.2802	0.95	0.0000
0.825	0.2	0.0000	0.4	-0.7220	0.6	-1.8066	0.8	-1.0339	0.95	-0.5166
0.850	0.2	-0.8882	0.4	-1.2765	0.6	-1.7618	0.8	-0.8450	0.95	-0.4760
0.875	0.2	0.0000	0.4	-1.8922	0.6	-1.4836	0.8	-0.8178	0.95	-0.4540
0.900	0.2	-1.0393	0.4	-2.0953	0.6	-1.2929	0.8	-0.8105	0.95	-0.4489
0.925	0.2	0.0000	0.4	-1.9776	0.6	-1.2335	0.8	-0.7525	0.95	-0.4506
0.950	0.2	-1.3374	0.4	-1.8110	0.6	-1.1395	0.8	-0.7241	0.95	-0.3584
0.975	0.2	0.0000	0.4	-1.7114	0.6	-1.0822	0.8	-0.7062	0.95	-0.3223
1.000	0.2	-3.0747	0.4	-1.7642	0.6	-0.9892	0.8	-0.7124	0.95	-0.3956
-0.200	0.2	0.2809	0.4	0.2641	0.6	0.2536	0.8	0.2536	0.95	-0.2973
-0.400	0.2	0.2882	0.4	0.2675	0.6	0.2293	0.8	0.0724	0.95	-0.3292
-0.600	0.2	0.2994	0.4	0.2742	0.6	0.2326	0.8	0.1021	0.95	-0.3680
-0.700	0.2	0.3165	0.4	0.2822	0.6	0.2432	0.8	0.1163	0.95	-0.4011
-0.800	0.2	0.3069	0.4	0.2976	0.6	0.2584	0.8	0.1485	0.95	-0.4238
-0.850	0.2	0.2828	0.4	0.2971	0.6	0.2675	0.8	0.1685	0.95	-0.4182
-0.900	0.2	0.0000	0.4	0.2643	0.6	0.2580	0.8	0.1891	0.95	-0.4077
-0.950	0.2	0.0399	0.4	0.1380	0.6	0.1987	0.8	0.1904	0.95	-0.1450
-0.975	0.2	0.0000	0.4	-0.1040	0.6	0.0489	0.8	0.1305	0.95	0.0061
-1.000	0.2	-2.7817	0.4	-1.7849	0.6	-1.0893	0.8	-0.7412	0.95	-0.3780

Medium Radius L.E.
 Run No. = 3, Point No. = 52
 $C_N = 0.563$, $C_m = -0.0790$
 $\alpha = 14.3^\circ$, $M_\infty = 0.400$
 $R_{mac} = 6.0 \times 10^6$



x/c_R	starb'd C_p	port C_p
0.10	-1.7302	0.0000
0.20	-3.0747	-2.7817
0.30	-2.4596	0.0000
0.40	-1.7642	-1.7849
0.50	-1.3596	0.0000
0.60	-0.9892	-1.0893
0.70	-0.8860	0.0000
0.80	-0.7124	-0.7412
0.90	0.0000	0.0000
0.95	-0.3956	-0.3780

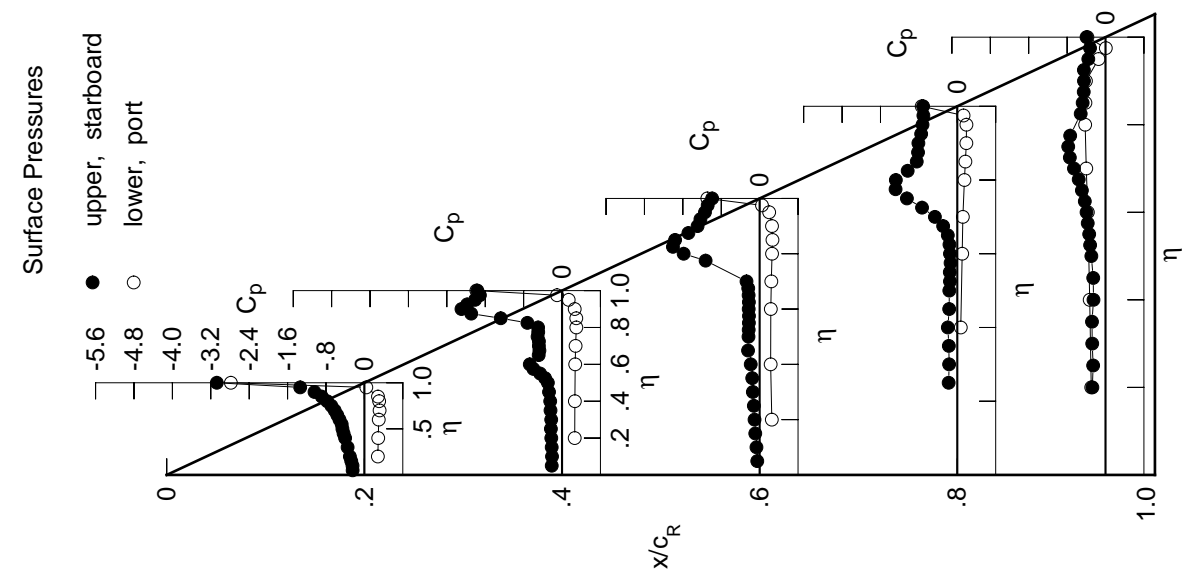

Table C1. Continued.

η	x/c_R	$C_{p,u}$	x/c_R	$C_{p,u}$	x/c_R	$C_{p,u}$	x/c_R	$C_{p,u}$	x/c_R	$C_{p,u}$
0.050	0.2	-0.2958	0.4	-0.2740	0.6	-0.0765	0.8	0.0765	0.95	0.0765
0.100		-0.2928		-0.2714		-0.0955		-0.0955		-0.0955
0.150		-0.3158		-0.2749		-0.1179		-0.1179		-0.1179
0.200		-0.3500		-0.2814		-0.1363		-0.1363		-0.1363
0.250		*****		-0.2903		-0.1498		-0.1938		-0.2768
0.300		-0.4104		-0.2936		-0.1931		-0.1955		-0.2999
0.350		*****		-0.3123		-0.2430		-0.2055		-0.2625
0.400		-0.5205		-0.3945		-0.2131		-0.1750		-0.2714
0.450		-0.5587		-0.4509		-0.2131		-0.1689		-0.3213
0.500		-0.6027		-0.3724		-0.2286		-0.1620		-0.3778
0.525		*****		-0.3718		-0.2343		-0.1679		-0.4163
0.550		-0.6363		-0.3724		-0.2464		-0.1801		-0.4502
0.575		*****		-0.3682		-0.2415		-0.2069		-0.5149
0.600		-0.6823		-0.3750		-0.2798		-0.2719		-0.5741
0.625		*****		*****		-0.3133		-0.3916		-0.6631
0.650		-0.7270		-0.3801		-0.4153		-0.5645		-0.7338
0.675		*****		-0.3798		-0.5716		-0.8140		-0.7803
0.700		-0.7704		-0.4066		-0.8368		-1.0708		-0.8224
0.725		*****		-0.5067		*****		-1.2615		-0.8370
0.750		-0.8361		-0.8667		*****		-1.3025		-0.7837
0.775		*****		-1.4704		-1.8791		-1.1401		-0.6402
0.800		-0.9240		-2.1095		-1.8247		-0.8588		*****
0.825		*****		-2.4312		-1.4195		-0.7541		-0.4735
0.850		-1.0444		-2.4445		-1.2390		-0.7421		-0.4453
0.875		*****		-2.1772		-1.2320		-0.7430		-0.4198
0.900		-1.2348		-1.8472		-1.2286		-0.7224		-0.4171
0.925		*****		-1.7417		-1.1566		-0.6756		-0.4305
0.950		-2.2367		-1.6346		-1.1350		-0.6507		-0.3397
0.975		*****		-1.5539		-1.1173		-0.6314		-0.3095
1.000		-3.0510		-1.5357		-1.0227		-0.6400		-0.3589
-0.200		0.3338		0.3033		0.2819		0.2819		0.2819
-0.400		0.3393		0.3135		0.2596		0.0883		0.3530
-0.600		0.3468		0.3145		0.2643		0.1256		0.4250
-0.700		0.3571		0.3247		0.2765		0.1335		0.4667
-0.800		0.3298		0.3292		0.2879		0.1711		0.4630
-0.850		0.2881		0.3186		0.2923		0.1885		0.4374
-0.900		*****		0.2683		0.2707		0.2087		0.4089
-0.950		-0.0558		0.1066		0.1794		0.1933		0.1336
-0.975		*****		-0.1717		-0.0069		0.1161		0.0026
-1.000		-3.2307		-1.5461		-1.0899		-0.6430		-0.3729

Medium Radius L.E.
 Run No. = 3, Point No. = 53
 $C_N = 0.649$, $C_M = -0.0812$
 $\alpha = 16.4^\circ$, $M_\infty = 0.400$
 $R_{mac} = 6.0 \times 10^6$

Leading Edge Pressures

● starboard
 ○ port

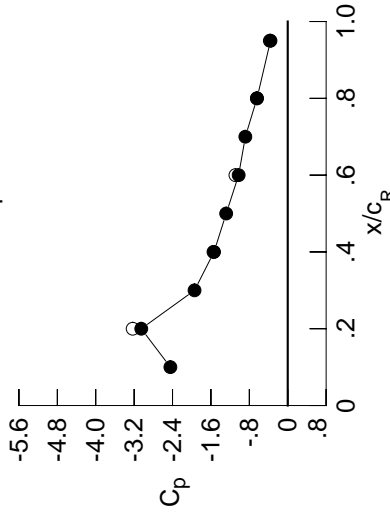

x/c_R	starb'd C_p	port C_p
0.10	-2.4448	*****
0.20	-3.0510	-3.2307
0.30	-1.9413	*****
0.40	-1.5357	-1.5461
0.50	-1.2821	*****
0.60	-1.0227	-1.0899
0.70	-0.8830	*****
0.80	-0.6400	-0.6430
0.90	*****	*****
0.95	-0.3589	-0.3729

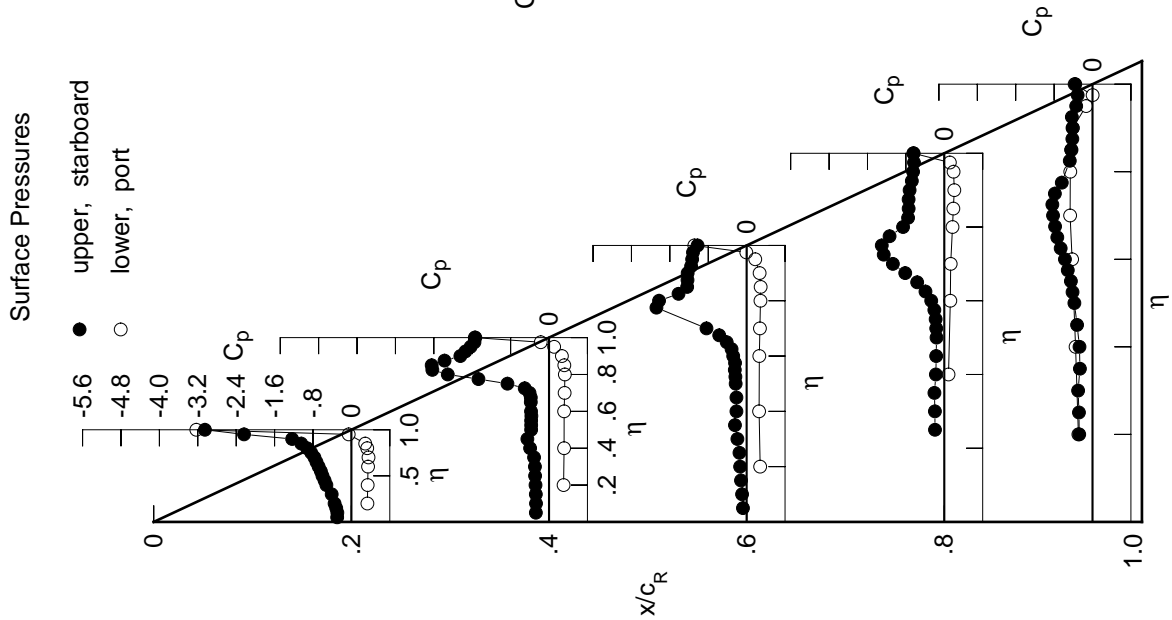
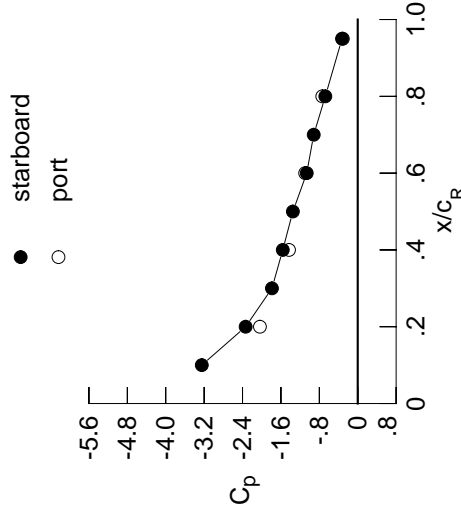

Table C1. Continued.

η	x/c_R	$C_{p,u}$	x/c_R	$C_{p,u}$	x/c_R	$C_{p,u}$	x/c_R	$C_{p,u}$	x/c_R	$C_{p,u}$
0.050	0.2	-0.3738	0.4	-0.3414	0.6	-0.1172	0.8	0.1172	0.95	0.2831
0.100		-0.3720		-0.3312		-0.1362		0.1362		0.2831
0.150		-0.3934		-0.3406		-0.1512		0.1512		0.2831
0.200		-0.4080		-0.3377		-0.1753		0.1753		0.2818
0.250		*****		-0.3660		-0.2151		-0.2153		0.2912
0.300		-0.4807		-0.4406		-0.2383		-0.2249		0.2957
0.350		*****		-0.3971		-0.2278		-0.2033		0.2589
0.400		-0.6276		-0.3962		-0.2383		-0.1926		0.3044
0.450		-0.7485		-0.3993		-0.2455		-0.1952		0.3548
0.500		-0.8622		-0.3980		-0.2794		-0.2311		0.4222
0.525		*****		-0.4017		-0.3049		-0.2644		0.4742
0.550		-0.6971		-0.4088		-0.3548		-0.3357		0.5342
0.575		-0.4080		-0.4092		-0.4352		-0.6260		0.6260
0.600		-0.6646		-0.4213		-0.5566		-0.5903		0.7122
0.625		*****		*****		-0.7185		-0.7936		0.8151
0.650		-0.6755		-0.5739		-1.0114		-1.0271		0.8831
0.675		*****		-0.7893		-1.3302		-1.2642		0.8974
0.700		-0.7224		-1.2029		-1.6489		-1.4020		0.8760
0.725		*****		-1.7358		*****		-1.3930		0.7637
0.750		-0.6698		-2.3317		*****		-1.2170		0.5511
0.775		*****		-2.6868		-1.7317		-0.9349		0.4132
0.800		-0.9283		-2.6890		-1.4027		-0.7967		0.5444
0.825		*****		-2.1993		-1.2946		-0.7787		0.4098
0.850		-2.8760		-1.8537		-1.2990		-0.7701		0.3873
0.875		*****		-1.8046		-1.3058		-0.7782		0.3707
0.900		-2.8302		-1.7957		-1.2725		-0.7545		0.3811
0.925		*****		-1.7012		-1.1853		-0.7086		0.3879
0.950		-2.4001		-1.6283		-1.1625		-0.6798		0.3197
0.975		*****		-1.5979		-1.1502		-0.6705		0.2865
1.000		-2.3352		-1.5620		-1.0622		-0.6751		0.3271
-0.200		$C_{p,l}$		0.3489		0.3206		0.2831		$C_{p,l}$
-0.400		0.3933		0.3552		0.3013		0.1238		0.3384
-0.600		0.3979		0.3572		0.2997		0.1561		0.4169
-0.700		0.3988		0.3617		0.3061		0.1666		0.4577
-0.800		0.3576		0.3573		0.3168		0.2003		0.4394
-0.850		0.3024		0.3368		0.3164		0.2160		0.4049
-0.900		*****		0.2660		0.2778		0.2264		0.3620
-0.950		-0.0871		0.0701		0.1514		0.1839		0.0936
-0.975		*****		-0.2404		-0.0712		0.0687		0.0219
-1.000		-2.0378		-1.4312		-1.0952		-0.7382		0.3108

Medium Radius L.E.
 Run No. = 3, Point No. = 54
 $C_N = 0.793$, $C_M = -0.1071$
 $\alpha = 18.4^\circ$, $M_\infty = 0.400$
 $R_{mac} = 6.0 \times 10^6$

Leading Edge Pressures



x/c_R	starb'd C_p	port C_p
0.10	-3.2487	*****
0.20	-2.3352	-2.0378
0.30	-1.7869	*****
0.40	-1.5620	-1.4312
0.50	-1.3511	*****
0.60	-1.0622	-1.0952
0.70	-0.9171	*****
0.80	-0.6751	-0.7382
0.90	*****	*****
0.95	-0.3271	-0.3108

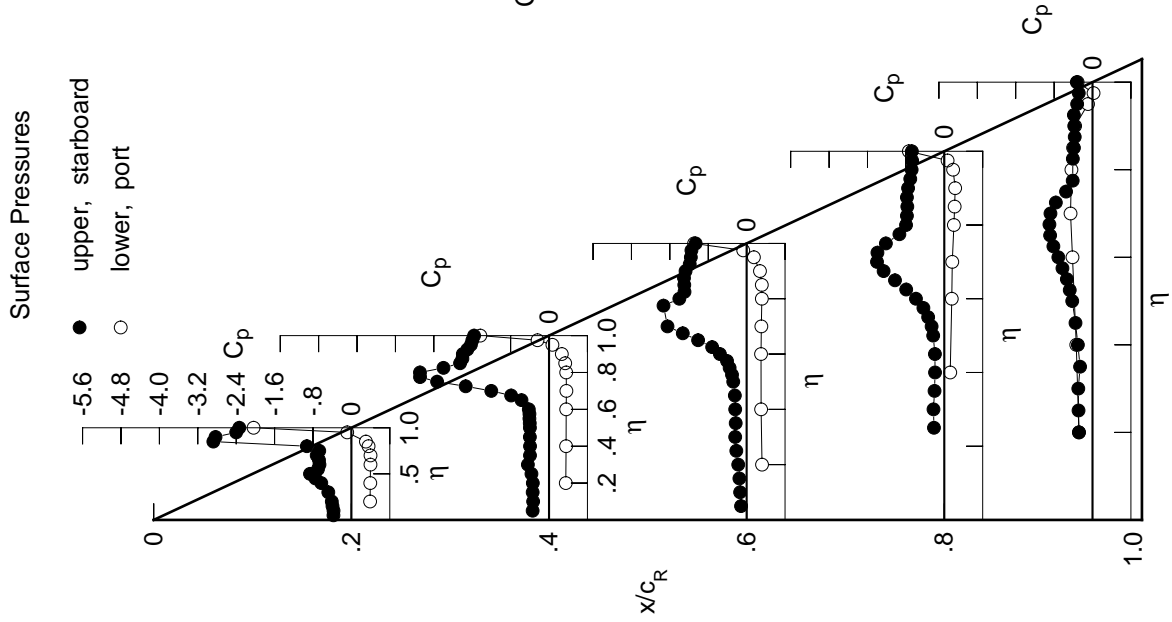
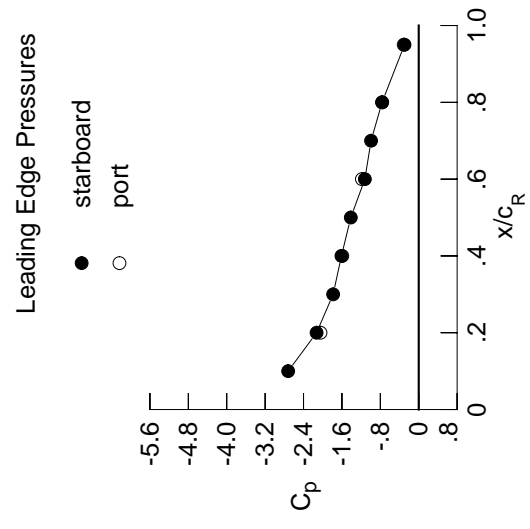

Table C1. Continued.

η	x/c_R	$C_{p,u}$	x/c_R	$C_{p,u}$	x/c_R	$C_{p,u}$	x/c_R	$C_{p,u}$	x/c_R	$C_{p,u}$
0.050		-0.4663	0.4080	-0.1563	0.8	0.2782				
0.100		-0.4677	0.3986	-0.1741	0.8	0.2864				
0.150		-0.4832	0.4032	-0.1927	0.8	0.2955				
0.200		-0.5023	0.4270	-0.2237	0.8	0.2861				
0.250		*****	-0.4557	-0.2534	0.8	0.3027				
0.300		-0.6735	-0.4450	-0.2714	0.8	0.3479				
0.350		*****	-0.4484	-0.2797	0.8	0.4330				
0.400		-0.6010	-0.4512	-0.2947	0.8	0.5063				
0.450		-0.6142	-0.4673	-0.3283	0.8	0.7037				
0.500		-0.6399	-0.4765	-0.4195	0.8	0.8107				
0.525		*****	-0.5018	-0.4989	0.8	0.9072				
0.550		-0.6382	-0.5484	-0.6159	0.8	0.9373				
0.575		*****	-0.6174	-0.7654	0.8	0.8623				
0.600		-0.6253	-0.7449	-1.0236	0.8	0.7124				
0.625		*****	*****	-1.2681	0.8	0.5016				
0.650		-0.6106	-1.3215	-1.6062	0.8	0.4258				
0.675		*****	-1.7635	-1.8777	0.8	0.4310				
0.700		-1.0482	-2.2509	-2.0403	0.8	0.9006				
0.725		*****	-2.6243	*****	0.8	0.4123				
0.750		-2.4814	-2.8303	*****	0.8	0.3829				
0.775		*****	-2.6117	-1.5263	0.8	0.3564				
0.800		-3.0647	-2.1309	-1.3671	0.8	0.3534				
0.825		*****	-1.8865	-1.3377	0.8	0.3493				
0.850		-2.8928	-1.8624	-1.3505	0.8	0.2982				
0.875		*****	-1.8715	-1.3713	0.8	0.2729				
0.900		-2.4315	-1.8422	-1.3324	0.8	0.2965				
0.925		*****	-1.7384	-1.2524	0.8	0.2985				
0.950		-2.2518	-1.6890	-1.2296	0.8	0.3544				
0.975		*****	-1.6543	-1.2160	0.8	0.4484				
1.000		-2.1282	-1.6101	-1.1221	0.8	0.4800				
-0.200		$C_{p,l}$	$C_{p,l}$	$C_{p,l}$	$C_{p,l}$	$C_{p,l}$	$C_{p,l}$	$C_{p,l}$	$C_{p,l}$	$C_{p,l}$
-0.400		0.4342	0.3851	0.3562	0.8	0.3947				
-0.600		0.4401	0.3979	0.3339	0.8	0.3431				
-0.700		0.4380	0.3920	0.3363	0.8	0.2412				
-0.800		0.4298	0.3969	0.3416	0.8	0.1730				
-0.800		0.3655	0.3797	0.3427	0.8	0.0733				
-0.850		0.2932	0.3452	0.3351	0.8	0.0207				
-0.900		*****	0.2484	0.2798	0.8	0.0298				
-0.950		-0.1769	0.0027	0.1115	0.8	0.0207				
-0.975		*****	-0.3701	-0.1547	0.8	0.0207				
-1.000		-2.0467	-1.5928	-1.1839	0.8	0.3124				

Medium Radius L.E.
 Run No. = 3, Point No. = 55
 $C_N = 0.911$, $C_m = -0.1217$
 $\alpha = 20.4^\circ$, $M_\infty = 0.400$
 $R_{mac} = 6.0 \times 10^6$



x/c_R	starb'd C_p	port C_p
0.10	-2.7202	*****
0.20	-2.1282	-2.0467
0.30	-1.7831	*****
0.40	-1.6101	-1.5928
0.50	-1.4154	*****
0.60	-1.1221	-1.1839
0.70	-0.9932	*****
0.80	-0.7636	-0.7609
0.90	*****	*****
0.95	-0.2965	-0.3124

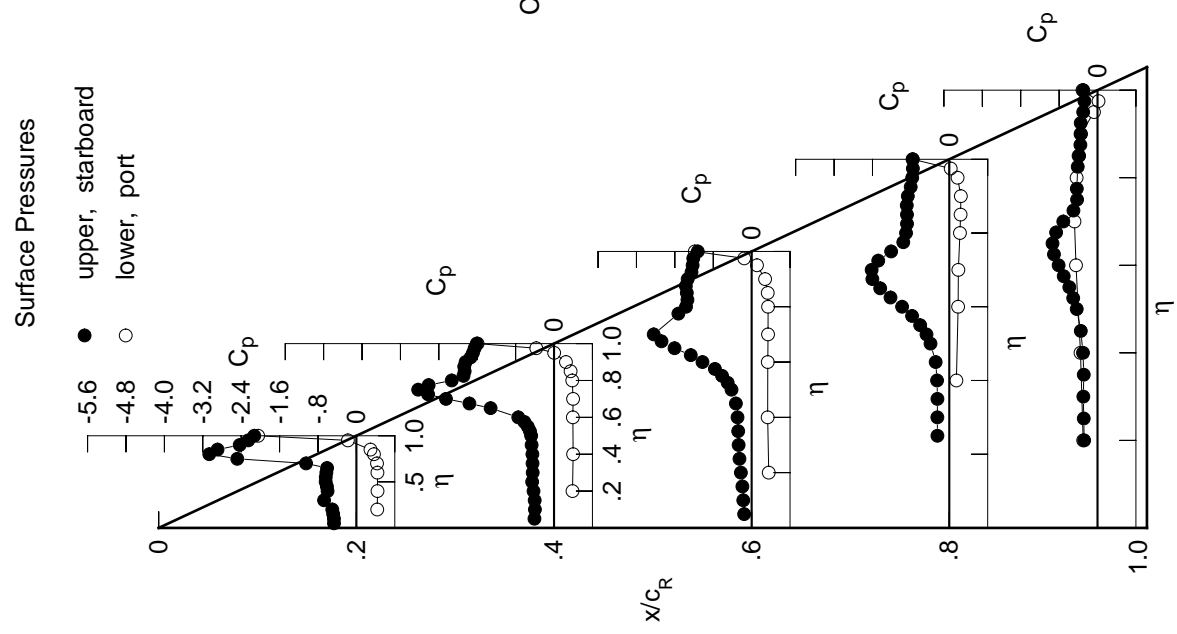
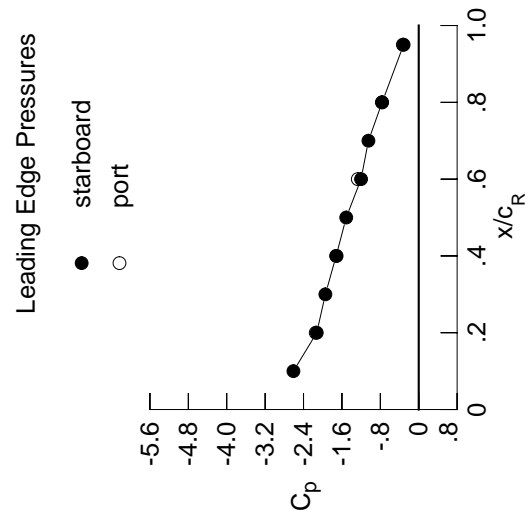

Table C1. Continued.

η	x/c_R	$C_{p,u}$	x/c_R	$C_{p,u}$	x/c_R	$C_{p,u}$	x/c_R	$C_{p,u}$	x/c_R	$C_{p,u}$
0.050	0.2	-0.5507	0.4	-0.4723	0.6	-0.1889	0.8	0.3900	0.95	0.3085
0.100		-0.5452		-0.4614		-0.2087		0.3671		-0.3085
0.150		-0.5832		-0.4770		-0.2329		0.3709		0.4628
0.200		-0.6728		-0.5081		-0.2680		0.3740		0.4763
0.250		*****		-0.4976		-0.2858		0.3678		-0.4263
0.300		-0.6195		-0.4989		-0.3126		0.3508		0.3814
0.350		*****		-0.5102		-0.3317		0.2771		0.3250
0.400		-0.6409		-0.5215		-0.3752		0.1612		-0.0597
0.450		-0.6607		-0.5540		-0.4425		-0.2382		0.0129
0.500		-0.6596		-0.6212		-0.6106		-0.7670		-0.3303
0.525		*****		-0.6984		-0.7425				
0.550		-0.6284		-0.8222		-0.9233				
0.575		*****		-0.9869		-1.1309				
0.600		-0.6531		-1.2492		-1.4415				
0.625		*****		*****		-1.7019				
0.650		-1.1125		-2.0595		-1.9987				
0.675		*****		-2.5194		-2.1624				
0.700		-2.4401		-2.8946		-2.1731				
0.725		*****		-2.9861		*****				
0.750		-3.5373		-2.7437		*****				
0.775		*****		-2.2149		-1.4402				
0.800		-3.5633		-1.9705		-1.4014				
0.825		*****		-1.9443		-1.3710				
0.850		-2.7697		-1.9512		-1.3856				
0.875		*****		-1.9725		-1.4052				
0.900		-2.4618		-1.9123		-1.3698				
0.925		*****		-1.8053		-1.3072				
0.950		-2.2653		-1.7748		-1.2920				
0.975		*****		-1.7517		-1.2900				
1.000		-2.1250		-1.7205		-1.2016				
-0.200		$C_{p,l}$		$C_{p,l}$		$C_{p,l}$		$C_{p,l}$		$C_{p,l}$
-0.400		0.4859		0.4307		0.3900		0.3085		0.3085
-0.600		0.4878		0.4344		0.3671		0.1771		-0.3617
-0.700		0.4740		0.4295		0.3709		0.2099		-0.4628
-0.800		0.4547		0.4263		0.3740		0.2185		-0.4763
-0.850		0.3689		0.3989		0.3678		0.2484		-0.4263
-0.900		0.2682		0.3507		0.3508		0.2584		-0.3814
-0.950		*****		0.2240		0.2771		0.2530		-0.3250
-0.975		-0.2787		-0.0721		0.0682		0.1612		-0.0597
-1.000		*****		-0.5012		-0.2382		-0.0077		0.0129
		-2.1453		-1.7111		-1.2695		-0.7670		-0.3303

Medium Radius L.E.
 Run No. = 3, Point No. = 56
 $C_N = 1.013$, $C_m = -0.1288$
 $\alpha = 22.4^\circ$, $M_\infty = 0.400$
 $R_{mac} = 6.0 \times 10^6$



x/c_R	starb'd C_p	port C_p
0.10	-2.6103	*****
0.20	-2.1250	-2.1453
0.30	-1.9445	*****
0.40	-1.7205	-1.7111
0.50	-1.5105	*****
0.60	-1.2016	-1.2695
0.70	-1.0477	*****
0.80	-0.7622	-0.7670
0.90	*****	*****
0.95	-0.3150	-0.3303

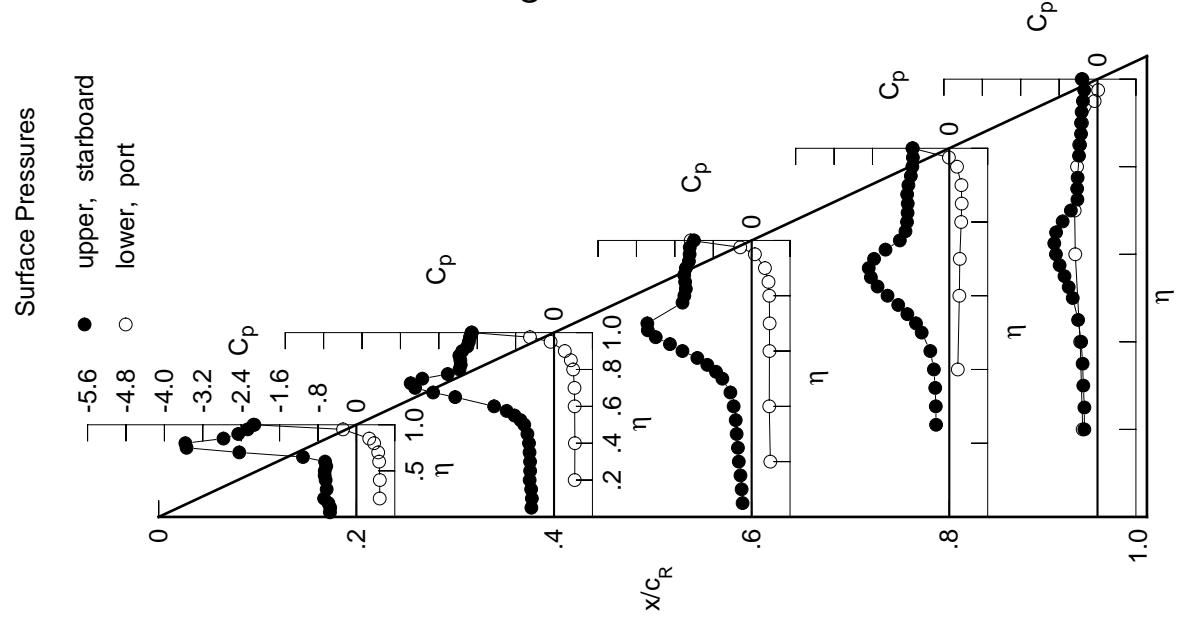
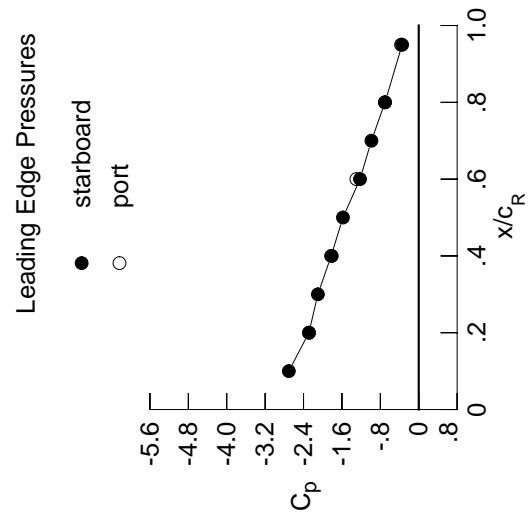

Table C1. Continued.

η	x/c_R	$C_{p,u}$	x/c_R	$C_{p,u}$	x/c_R	$C_{p,u}$	x/c_R	$C_{p,u}$	x/c_R	$C_{p,u}$
0.050		-0.6317	0.2	-0.5289	0.4	-0.2162	0.6	0.2162	0.8	0.3066
0.100		-0.6300		-0.5188		-0.2340		-0.2340		-0.3360
0.150		-0.7148		-0.5311		-0.2534		-0.2534		-0.3472
0.200		-0.7158		-0.5697		-0.2780		-0.2780		-0.3762
0.250		*****		-0.5573		-0.3336		-0.3336		-0.4343
0.300		-0.7045		-0.5735		-0.3572		-0.3572		-0.5255
0.350		*****		-0.5844		-0.3923		-0.3923		-0.6445
0.400		-0.7288		-0.6237		-0.4585		-0.4585		-0.7182
0.450		-0.7347		-0.6934		-0.5835		-0.5835		-0.7826
0.500		-0.7299		-0.8436		-0.8208		-0.8208		-0.8372
0.525		*****		-0.9867		-1.0038		-1.0038		-0.8623
0.550		-0.7417		-1.1775		-1.2206		-1.2206		-0.8605
0.575		*****		-1.4388		-1.4585		-1.4585		-0.8299
0.600		-0.9918		-1.7620		-1.7799		-1.7799		-0.6760
0.625		*****		*****		-2.0060		-2.0060		-0.5349
0.650		-1.9426		-2.6066		-2.2285		-2.2285		-0.4216
0.675		*****		-2.9801		-2.2772		-2.2772		-0.4165
0.700		-3.3237		-3.1196		-2.1689		-2.1689		-0.4155
0.725		*****		-2.9076		*****		-1.10586		-0.4024
0.750		-4.1432		-2.4467		*****		-0.8493		-0.3914
0.775		*****		-2.0865		-1.4304		-0.7932		-0.3726
0.800		-3.4628		-2.0383		-1.4156		-0.7877		-0.3674
0.825		*****		-2.0227		-1.3958		-0.7667		-0.3516
0.850		-2.7121		-2.0479		-1.4010		-0.7592		-0.3271
0.875		*****		-2.0551		-1.4102		-0.7597		-0.3231
0.900		-2.6060		-1.9887		-1.3796		-0.7469		-0.3461
0.925		*****		-1.8996		-1.3193		-0.7188		*****
0.950		-2.4024		-1.8730		-1.3140		-0.6885		*****
0.975		*****		-1.8689		-1.3050		-0.6891		*****
1.000		-2.2881		-1.8252		-1.2234		-0.7020		*****
-0.200		*****		*****		*****		*****		*****
-0.400		0.5322		0.4711		0.4235		0.3236		*****
-0.600		0.5321		0.4770		0.3969		0.1920		0.4166
-0.700		0.5100		0.4618		0.4013		0.2371		0.4846
-0.800		0.4753		0.4574		0.4039		0.2393		0.4951
-0.850		0.3657		0.4106		0.3914		0.2684		0.4249
-0.900		0.2515		0.3513		0.3636		0.2737		0.3787
-0.950		*****		0.2008		0.2753		0.2622		0.3158
-0.975		*****		-0.3887		-0.1441		0.0318		0.1540
-1.000		*****		-0.6238		-0.3065		-0.0275		-0.0036
		-2.2840		-1.8120		-1.2989		-0.7056		-0.3687

Medium Radius L.E.
 Run No. = 3, Point No. = 57
 $C_N = 1.102$, $C_M = -0.1358$
 $\alpha = 24.5^\circ$, $M_\infty = 0.400$
 $R_{mac} = 6.0 \times 10^6$



x/c_R	starb'd C_p	port C_p
0.10	-2.7064	*****
0.20	-2.2881	-2.2840
0.30	-2.1010	*****
0.40	-1.8252	-1.8120
0.50	-1.5783	*****
0.60	-1.2234	-1.2989
0.70	-0.9853	*****
0.80	-0.7020	-0.7056
0.90	*****	*****
0.95	-0.3461	-0.3687

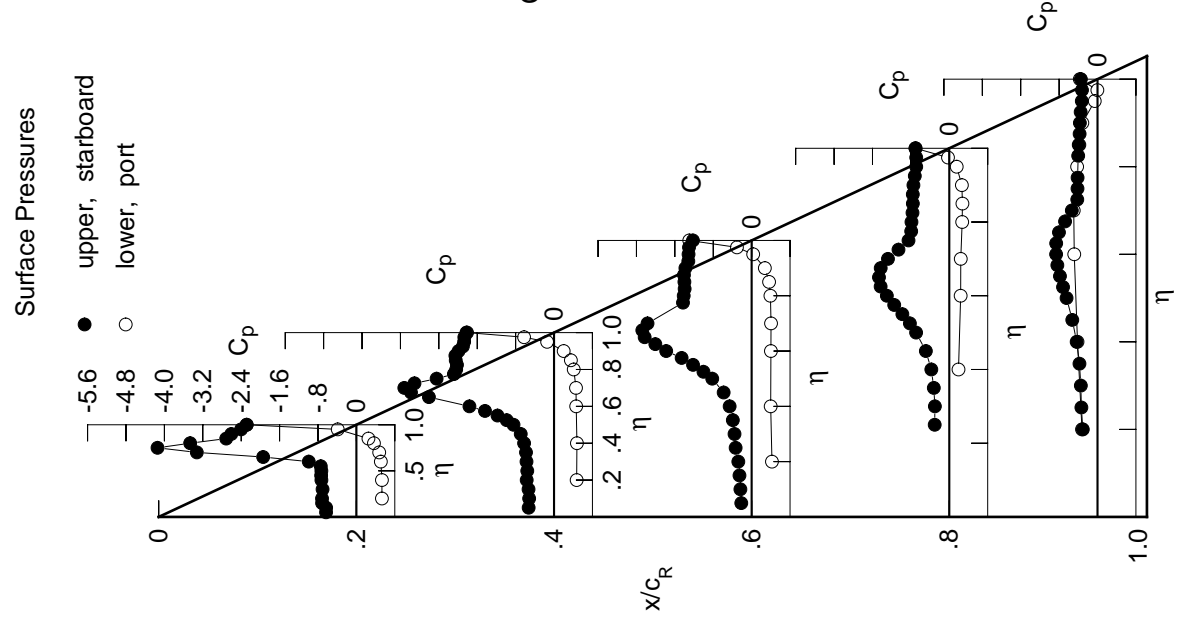
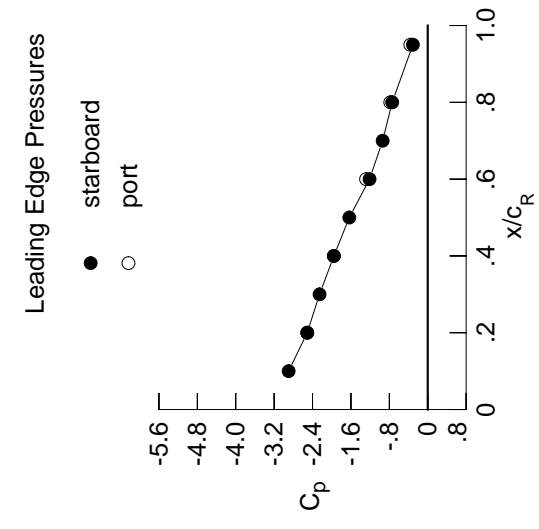

Table C1. Concluded.

η	x/c_R	$C_{p,u}$	x/c_R	$C_{p,u}$	x/c_R	$C_{p,u}$	x/c_R	$C_{p,u}$
0.050	0.2	-0.7204	0.4	-0.5952	0.6	-0.2476	0.8	0.95
0.100		-0.7248		-0.5852		-0.2698		
0.150		-0.8164		-0.5854		-0.2925		
0.200		-0.8194		-0.6364		-0.3220		
0.250		*****		-0.6514		-0.3491		-0.3089
0.300		-0.8128		-0.6519		-0.4031		-0.3803
0.350		*****		-0.6898		-0.4608		-0.4035
0.400		-0.8365		-0.7575		-0.5859		-0.4317
0.450		-0.8500		-0.8899		-0.7608		-0.5042
0.500		-0.8824		-1.1279		-1.0555		-0.5991
0.525		*****		-1.3330		-1.2650		-0.7196
0.550		-1.0203		-1.5839		-1.5085		-0.7813
0.575		*****		-1.8930		-1.7459		-0.8300
0.600		-1.5658		-2.2426		-2.0405		-0.8686
0.625		*****		*****		-2.2058		-0.8835
0.650		-2.7795		-3.0091		-2.3207		-0.8664
0.675		*****		-3.2191		-2.2655		-0.8106
0.700		-4.0892		-3.1374		-2.0745		-0.6986
0.725		*****		-2.7582		*****		-0.5843
0.750		-4.3548		-2.3258		*****		-0.4757
0.775		*****		-2.1554		-1.3991		-0.4472
0.800		-3.0665		-2.1400		-1.3894		-0.4570
0.825		*****		-2.1361		-1.3617		*****
0.850		-2.8682		-2.1581		-1.3714		-0.4759
0.875		*****		-2.1610		-1.3730		-0.4562
0.900		-2.7526		-2.0956		-1.3504		-0.4338
0.925		*****		-2.0162		-1.2912		-0.4239
0.950		-2.6103		-1.9974		-1.2725		-0.4204
0.975		*****		-1.9902		-1.2902		-0.3666
1.000		-2.5107		-1.9553		-1.2119		-0.3317
								-0.3089
-0.200		$C_{p,l}$		$C_{p,l}$		$C_{p,l}$		$C_{p,l}$
-0.400		0.5821		0.5154		0.4599		0.3265
-0.600		0.5777		0.5200		0.4388		0.2264
-0.700		0.5426		0.5036		0.4371		0.2587
-0.800		0.4969		0.4874		0.4380		0.2645
-0.850		0.3593		0.4250		0.4162		0.2889
-0.900		0.2216		0.3470		0.3798		0.2918
-0.950		*****		0.1691		0.2723		0.2672
-0.975		-0.5147		-0.2256		-0.0011		0.1294
-1.000		*****		-0.7604		-0.3654		-0.0325
		-2.5092		-1.9580		-1.2847		-0.7802
								-0.3630

Medium Radius L.E.
 Run No. = 3, Point No. = 58
 $C_N = 1.217$, $C_m = -0.1568$
 $\alpha = 26.5^\circ$, $M_\infty = 0.400$
 $R_{mac} = 6.0 \times 10^6$



x/c_R	starb'd C_p	port C_p
0.10	-2.8980	*****
0.20	-2.5107	-2.5092
0.30	-2.2539	*****
0.40	-1.9553	-1.9580
0.50	-1.6335	*****
0.60	-1.2119	-1.2847
0.70	-0.9393	*****
0.80	-0.7403	-0.7802
0.90	*****	*****
0.95	-0.3089	-0.3630

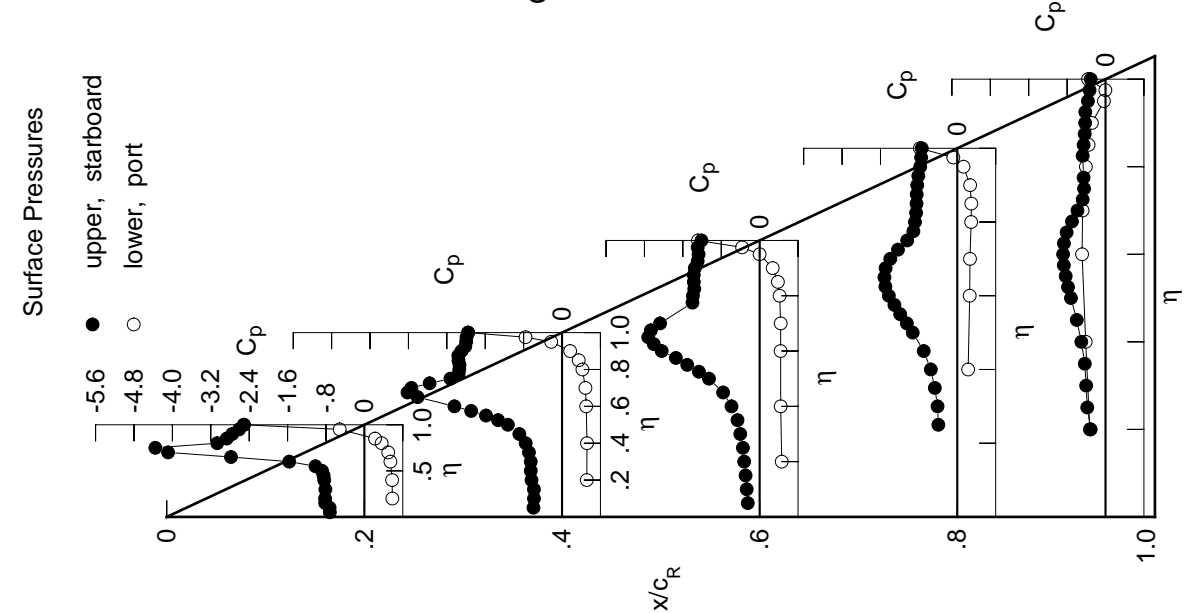
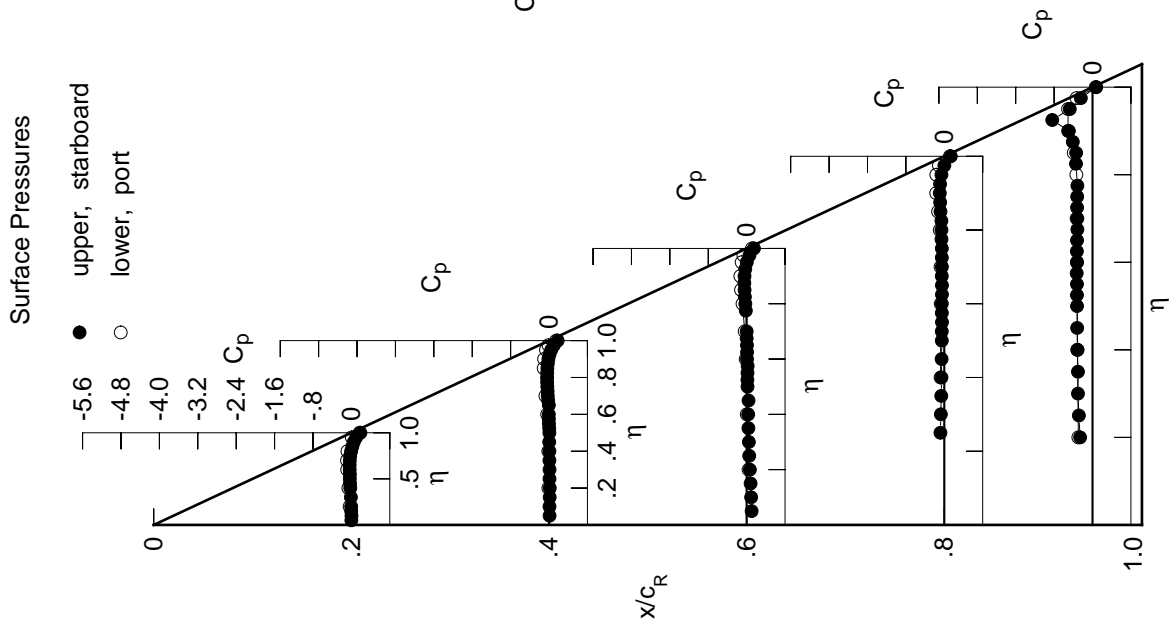

Table C2. Tabulations and Plots of Surface Pressure Coefficients.

η	x/c_R .2	x/c_R .4	x/c_R .6	x/c_R .8	x/c_R .95
	$C_{p,u}$	$C_{p,u}$	$C_{p,u}$	$C_{p,u}$	$C_{p,u}$
0.050	-0.0005	0.0109	0.1043	0.2583	0.2583
0.100	0.0013	0.0093	0.0939	0.2841	0.2841
0.150	-0.0038	0.0134	0.0824	0.3029	0.3029
0.200	-0.0043	0.0149	0.0671	0.3032	0.3032
0.250	0.0000	0.0097	0.0535	0.3155	0.3155
0.300	-0.0105	0.0103	0.0466	0.3199	0.3199
0.350	0.0000	0.0082	0.0365	0.3221	0.3221
0.400	-0.0229	0.0082	0.0320	0.3238	0.3238
0.450	-0.0277	0.0044	0.0396	0.3241	0.3241
0.500	-0.0327	0.0071	0.0183	0.3258	0.3258
0.525	0.0000	0.0031	0.0161	0.3255	0.3255
0.550	-0.0313	-0.0024	0.0178	0.3224	0.3224
0.575	0.0000	-0.0031	0.0211	0.3150	0.3150
0.600	-0.0354	-0.0052	0.0079	0.3163	0.3163
0.625	0.0000	0.0000	0.0094	0.3220	0.3220
0.650	-0.0361	-0.0042	0.0073	0.3188	0.3188
0.675	0.0000	-0.0177	0.0005	0.3156	0.3156
0.700	-0.0339	-0.0252	0.0005	0.0593	0.0593
0.725	0.0000	-0.0298	0.0000	0.0512	0.0512
0.750	-0.0241	-0.0353	0.0000	0.0581	0.0581
0.775	0.0000	-0.0389	-0.0165	0.0601	0.0601
0.800	-0.0055	-0.0411	-0.0275	0.0601	0.0601
0.825	0.0000	-0.0378	-0.0365	0.0795	0.0795
0.850	0.0192	-0.0347	-0.0433	0.0795	0.0795
0.875	0.0000	-0.0256	-0.0481	0.0852	0.0852
0.900	0.0500	-0.0128	-0.0441	0.0935	0.0935
0.925	0.0000	0.0097	-0.0287	0.0878	0.0878
0.950	0.0989	0.0475	0.0023	0.0590	0.04740
0.975	0.0000	0.1017	0.0592	0.0019	0.2435
1.000	0.1881	0.1796	0.1523	0.1352	0.0771
	$C_{p,l}$	$C_{p,l}$	$C_{p,l}$	$C_{p,l}$	$C_{p,l}$
-0.200	-0.0364	-0.0131	0.0399	0.2952	0.2952
-0.400	-0.0627	-0.0150	0.0028	0.3129	0.3129
-0.600	-0.0875	-0.0392	0.0202	0.0738	0.3209
-0.700	-0.0910	-0.0751	-0.0405	0.0777	0.3303
-0.800	-0.0826	0.0000	-0.0858	0.0944	0.3371
-0.850	0.0000	-0.1110	-0.1167	0.1289	0.3923
-0.900	0.0000	-0.1035	-0.1323	0.1674	0.5087
-0.950	0.0083	-0.0641	-0.1041	0.1658	0.5096
-0.975	0.0000	-0.0111	-0.0674	0.1120	0.3339
-1.000	0.1713	0.1499	0.1110	0.1166	0.0669

Medium Radius L.E.
 Run No. = 21, Point No. = 407
 $C_N = -0.025$, $C_m = -0.0021$
 $\alpha = -0.8^\circ$, $M_\infty = 0.398$
 $R_{mac} = 60.6 \times 10^6$



Leading Edge Pressures

● starboard
 ○ port

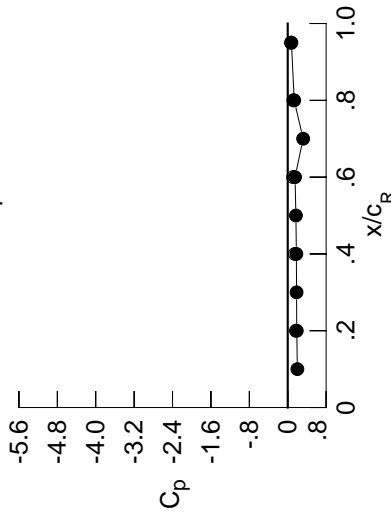

x/c_R	starb'd C_p	port C_p
0.10	0.2006	0.1713
0.20	0.1881	0.1499
0.30	0.1841	0.1703
0.40	0.1796	0.1110
0.50	0.1703	0.3206
0.60	0.1523	0.1352
0.70	0.3206	0.1166
0.80	0.1352	0.0771
0.90	0.0771	0.0669
0.95	0.0771	0.0669

Table C2. Continued.

η	x/c_R .2	x/c_R .4	x/c_R .6	x/c_R .8	x/c_R .95
	$C_{p,u}$	$C_{p,u}$	$C_{p,u}$	$C_{p,u}$	$C_{p,u}$
0.050	-0.0051	0.0072	0.1026	0.1026	0.1026
0.100	-0.0030	0.0050	0.0908	0.0908	0.0908
0.150	-0.0093	0.0093	0.0803	0.0803	0.0803
0.200	-0.0083	0.0106	0.0654	0.0654	-0.2553
0.250	0.0065	0.0065	0.0510	0.0510	-0.2820
0.300	-0.0151	0.0058	0.0429	-0.0726	-0.3004
0.350	0.0000	0.0043	0.0336	-0.0673	-0.3015
0.400	-0.0288	0.0028	0.0289	-0.0602	-0.3133
0.450	-0.0332	0.0000	0.0364	-0.0586	-0.3176
0.500	-0.0393	0.0025	0.0139	-0.0548	-0.3204
0.525	0.0000	-0.0033	0.0119	-0.0554	-0.3229
0.550	-0.0373	-0.0083	0.0135	-0.0521	-0.3218
0.575	0.0000	-0.0089	0.0166	-0.0527	-0.3259
0.600	-0.0427	-0.0115	0.0034	-0.0546	-0.3242
0.625	0.0000	0.0000	0.0055	-0.0518	-0.3236
0.650	-0.0440	-0.0101	0.0016	-0.0529	-0.3210
0.675	0.0000	-0.0237	-0.0050	-0.0559	-0.3128
0.700	-0.0416	-0.0310	-0.0063	-0.0551	-0.3125
0.725	0.0000	-0.0377	0.0000	-0.0548	-0.3188
0.750	-0.0333	-0.0422	0.0000	-0.0566	-0.3139
0.775	0.0000	-0.0469	-0.0236	-0.0627	-0.3082
0.800	-0.0160	-0.0498	-0.0359	-0.0677	0.0000
0.825	0.0000	-0.0478	-0.0448	-0.0659	-0.3376
0.850	0.0082	-0.0454	-0.0539	-0.0871	-0.3331
0.875	0.0000	-0.0382	-0.0588	-0.0950	-0.4064
0.900	0.0383	-0.0262	-0.0572	-0.1058	-0.4926
0.925	0.0000	-0.0029	-0.0424	-0.1019	-0.8517
0.950	0.0847	0.0318	-0.0140	-0.0753	-0.4873
0.975	0.0000	0.0885	0.0442	-0.0164	-0.2606
1.000	0.1962	0.1906	0.1730	0.1542	0.0920
	$C_{p,l}$	$C_{p,l}$	$C_{p,l}$	$C_{p,l}$	$C_{p,l}$
-0.200	-0.0315	-0.0090	0.0436	0.0436	-0.2992
-0.400	-0.0549	-0.0125	0.0074	-0.0757	-0.3109
-0.600	-0.0776	-0.0341	-0.0160	-0.0715	-0.3226
-0.700	-0.0806	-0.0663	-0.0345	-0.0748	-0.3321
-0.800	-0.0691	0.0000	-0.0776	-0.0898	-0.3397
-0.850	0.0000	-0.0998	-0.1067	-0.1205	-0.3931
-0.900	0.0000	-0.0898	-0.1196	-0.1558	-0.5080
-0.950	0.0249	-0.0478	-0.0873	-0.1488	-0.5012
-0.975	0.0000	0.0061	-0.0476	-0.0917	-0.3217
-1.000	0.1808	0.1644	0.1283	0.1367	0.0779

Surface Pressures

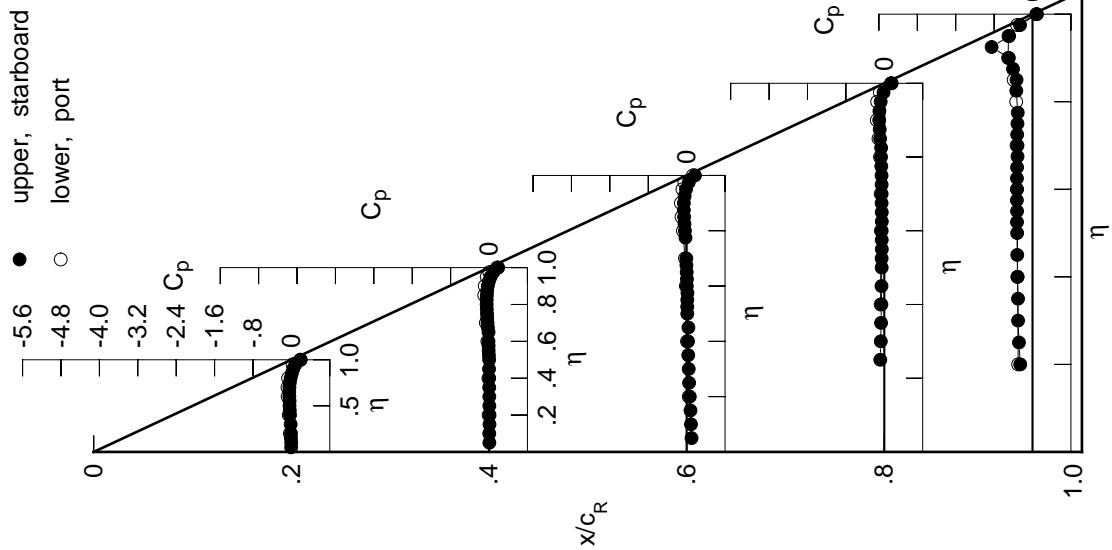

Medium Radius L.E.
 Run No. = 21, Point No. = 408
 $C_N = -0.020$, $C_m = -0.0003$
 $\alpha = -0.3^\circ$, $M_\infty = 0.398$
 $R_{mac} = 59.5 \times 10^6$

Leading Edge Pressures

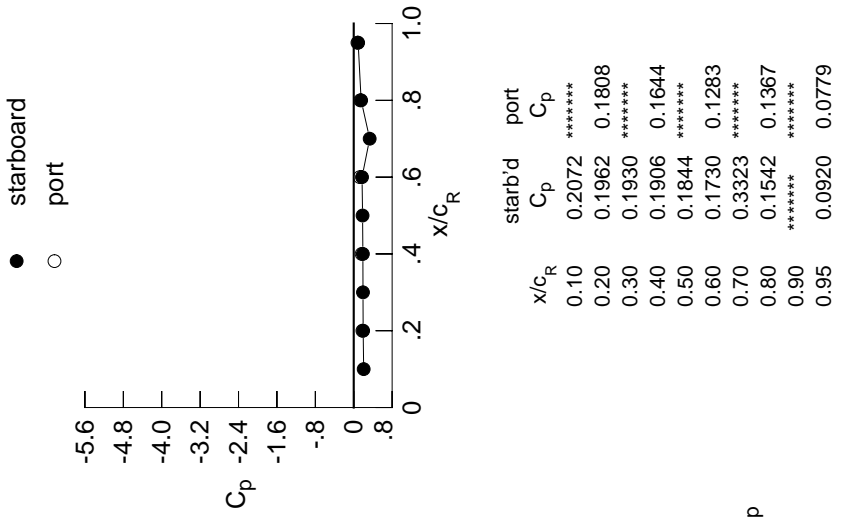

x/c_R	starb'd C_p	port C_p
0.10	0.2072	0.1808
0.20	0.1962	0.1808
0.30	0.1930	0.1808
0.40	0.1906	0.1644
0.50	0.1844	0.1844
0.60	0.1730	0.1283
0.70	0.3323	0.3323
0.80	0.1542	0.1367
0.90	0.0920	0.0779

Table C2. Continued.

η	$x/c_R = .2$		$x/c_R = .4$		$x/c_R = .6$		$x/c_R = .8$		$x/c_R = .95$	
	$C_{p,u}$	$C_{p,u}$	$C_{p,u}$	$C_{p,u}$	$C_{p,u}$	$C_{p,u}$	$C_{p,u}$	$C_{p,u}$	$C_{p,u}$	$C_{p,u}$
0.050	-0.0253	-0.0079	0.0913	0.0913	0.0913	0.0913	0.0913	0.0913	0.0913	0.0913
0.100	-0.0232	-0.0104	0.0796	0.0796	0.0796	0.0796	0.0796	0.0796	0.0796	0.0796
0.150	-0.0290	-0.0067	0.0682	0.0682	0.0682	0.0682	0.0682	0.0682	0.0682	0.0682
0.200	-0.0292	-0.0055	0.0539	0.0539	0.0539	0.0539	0.0539	0.0539	0.0539	0.0539
0.250	*****	-0.0109	0.0388	0.0388	0.0388	0.0388	0.0388	0.0388	0.0388	0.0388
0.300	-0.0363	-0.0111	0.0320	0.0320	0.0320	0.0320	0.0320	0.0320	0.0320	0.0320
0.350	*****	-0.0138	0.0193	0.0193	0.0193	0.0193	0.0193	0.0193	0.0193	0.0193
0.400	-0.0532	-0.0144	0.0153	0.0153	0.0153	0.0153	0.0153	0.0153	0.0153	0.0153
0.450	-0.0588	-0.0193	0.0240	0.0240	0.0240	0.0240	0.0240	0.0240	0.0240	0.0240
0.500	-0.0658	-0.0171	-0.0003	-0.0003	-0.0003	-0.0003	-0.0003	-0.0003	-0.0003	-0.0003
0.525	*****	-0.0227	-0.0030	-0.0030	-0.0030	-0.0030	-0.0030	-0.0030	-0.0030	-0.0030
0.550	-0.0666	-0.0293	-0.0038	-0.0038	-0.0038	-0.0038	-0.0038	-0.0038	-0.0038	-0.0038
0.575	*****	-0.0315	0.0010	0.0010	0.0010	0.0010	0.0010	0.0010	0.0010	0.0010
0.600	-0.0740	-0.0341	-0.0127	-0.0127	-0.0127	-0.0127	-0.0127	-0.0127	-0.0127	-0.0127
0.625	*****	*****	-0.0131	-0.0131	-0.0131	-0.0131	-0.0131	-0.0131	-0.0131	-0.0131
0.650	-0.0781	-0.0355	-0.0177	-0.0177	-0.0177	-0.0177	-0.0177	-0.0177	-0.0177	-0.0177
0.675	*****	-0.0513	-0.0248	-0.0248	-0.0248	-0.0248	-0.0248	-0.0248	-0.0248	-0.0248
0.700	-0.0792	-0.0602	-0.0263	-0.0263	-0.0263	-0.0263	-0.0263	-0.0263	-0.0263	-0.0263
0.725	*****	-0.0693	*****	*****	*****	*****	*****	*****	*****	*****
0.750	-0.0733	-0.0766	*****	*****	*****	*****	*****	*****	*****	*****
0.775	*****	-0.0845	-0.0509	-0.0509	-0.0509	-0.0509	-0.0509	-0.0509	-0.0509	-0.0509
0.800	-0.0596	-0.0909	-0.0665	-0.0665	-0.0665	-0.0665	-0.0665	-0.0665	-0.0665	-0.0665
0.825	*****	-0.0916	-0.0805	-0.0805	-0.0805	-0.0805	-0.0805	-0.0805	-0.0805	-0.0805
0.850	-0.0382	-0.0939	-0.0945	-0.0945	-0.0945	-0.0945	-0.0945	-0.0945	-0.0945	-0.0945
0.875	*****	-0.0890	-0.1033	-0.1033	-0.1033	-0.1033	-0.1033	-0.1033	-0.1033	-0.1033
0.900	-0.0114	-0.0814	-0.1099	-0.1099	-0.1099	-0.1099	-0.1099	-0.1099	-0.1099	-0.1099
0.925	*****	-0.0645	-0.1011	-0.1011	-0.1011	-0.1011	-0.1011	-0.1011	-0.1011	-0.1011
0.950	0.0319	-0.0315	-0.0826	-0.0826	-0.0826	-0.0826	-0.0826	-0.0826	-0.0826	-0.0826
0.975	*****	0.0172	-0.0318	-0.0318	-0.0318	-0.0318	-0.0318	-0.0318	-0.0318	-0.0318
1.000	0.1936	0.1871	0.1785	0.1785	0.1785	0.1785	0.1785	0.1785	0.1785	0.1785
	$C_{p,l}$	$C_{p,l}$	$C_{p,l}$	$C_{p,l}$	$C_{p,l}$	$C_{p,l}$	$C_{p,l}$	$C_{p,l}$	$C_{p,l}$	$C_{p,l}$
-0.200	-0.0098	0.0067	0.0556	0.0556	0.0556	0.0556	0.0556	0.0556	0.0556	0.0556
-0.400	-0.0306	0.0098	0.0200	0.0200	0.0200	0.0200	0.0200	0.0200	0.0200	0.0200
-0.600	-0.0462	-0.0113	0.0010	0.0010	0.0010	0.0010	0.0010	0.0010	0.0010	0.0010
-0.700	-0.0430	-0.0377	-0.0122	-0.0122	-0.0122	-0.0122	-0.0122	-0.0122	-0.0122	-0.0122
-0.800	-0.0261	*****	-0.0460	-0.0460	-0.0460	-0.0460	-0.0460	-0.0460	-0.0460	-0.0460
-0.850	*****	-0.0522	-0.0663	-0.0663	-0.0663	-0.0663	-0.0663	-0.0663	-0.0663	-0.0663
-0.900	*****	-0.0340	-0.0681	-0.0681	-0.0681	-0.0681	-0.0681	-0.0681	-0.0681	-0.0681
-0.950	0.0795	0.0178	-0.0203	-0.0203	-0.0203	-0.0203	-0.0203	-0.0203	-0.0203	-0.0203
-0.975	*****	0.0808	0.0282	0.0282	0.0282	0.0282	0.0282	0.0282	0.0282	0.0282
-1.000	0.1866	0.1797	0.1480	0.1480	0.1480	0.1480	0.1480	0.1480	0.1480	0.1480

Medium Radius L.E.
 Run No. = 21, Point No. = 409
 $C_N = 0.018$, $C_m = -0.0050$
 $\alpha = 0.8^\circ$, $M_\infty = 0.398$
 $R_{mac} = 60.9 \times 10^6$

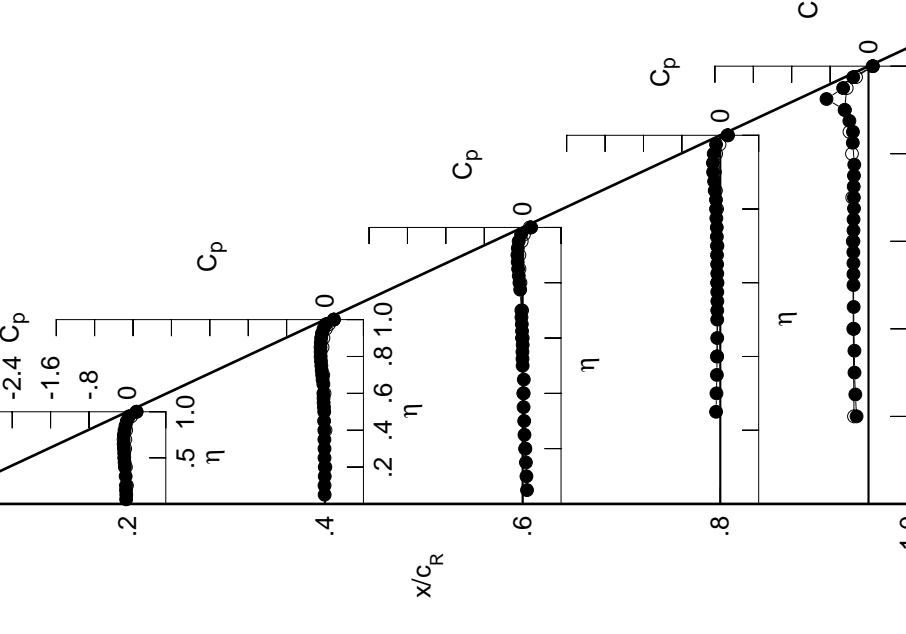
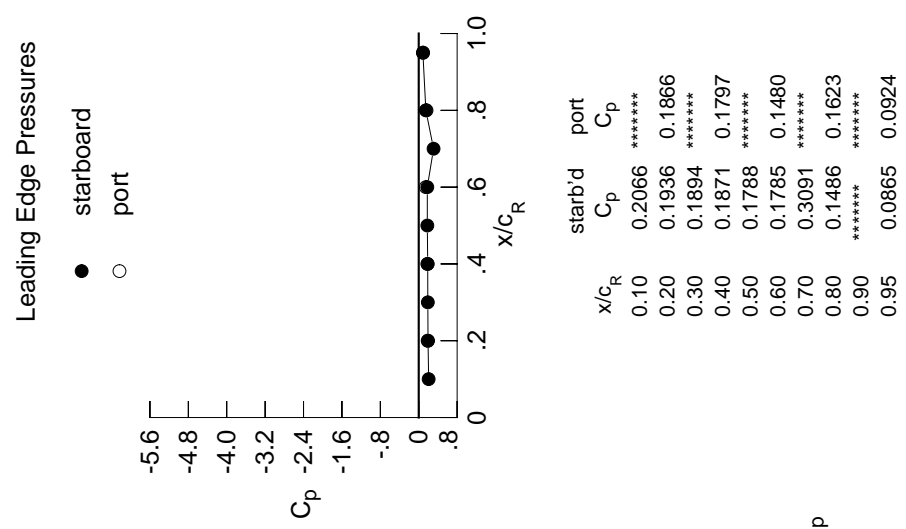

x/c_R	starb'd C_p	port C_p
0.10	0.2066	*****
0.20	0.1936	0.1866
0.30	0.1894	*****
0.40	0.1871	0.1797
0.50	0.1788	*****
0.60	0.1785	0.1480
0.70	0.3091	*****
0.80	0.1486	0.1623
0.90	*****	*****
0.95	0.0865	0.0924

Table C2. Continued.

η	x/c_R .2	x/c_R .4	x/c_R .6	x/c_R .8	x/c_R .95
	$C_{p,u}$	$C_{p,u}$	$C_{p,u}$	$C_{p,u}$	$C_{p,u}$
0.050	-0.0440	-0.0218	0.0822	*****	*****
0.100	-0.0412	-0.0247	0.0705	*****	*****
0.150	-0.0477	-0.0211	0.0596	*****	*****
0.200	-0.0476	-0.0206	0.0448	*****	-0.2452
0.250	*****	-0.0257	0.0286	-0.0959	-0.2689
0.300	-0.0540	-0.0255	0.0205	-0.0865	-0.2869
0.350	*****	-0.0289	0.0101	-0.0780	-0.2884
0.400	-0.0739	-0.0306	0.0031	-0.0743	-0.3010
0.450	-0.0817	-0.0374	0.0117	-0.0726	-0.3038
0.500	-0.0908	-0.0346	-0.0147	-0.0717	-0.3077
0.525	*****	-0.0425	-0.0161	-0.0716	-0.3076
0.550	-0.0931	-0.0484	-0.0176	-0.0697	-0.3082
0.575	*****	-0.0513	-0.0145	-0.0715	-0.3122
0.600	-0.1039	-0.0548	-0.0288	-0.0751	-0.3108
0.625	*****	*****	-0.0291	-0.0727	-0.3088
0.650	-0.1100	-0.0580	-0.0342	-0.0767	-0.3067
0.675	*****	-0.0750	-0.0438	-0.0795	-0.2973
0.700	-0.1158	-0.0875	-0.0462	-0.0824	-0.2973
0.725	*****	-0.0977	*****	-0.0847	-0.3017
0.750	-0.1119	-0.1063	*****	-0.0874	-0.2971
0.775	*****	-0.1179	-0.0750	-0.0984	-0.2900
0.800	-0.1010	-0.1276	-0.0946	-0.1080	*****
0.825	*****	-0.1320	-0.1125	-0.1107	-0.3220
0.850	-0.0840	-0.1377	-0.1325	-0.1426	-0.3207
0.875	*****	-0.1376	-0.1469	-0.1628	-0.3998
0.900	-0.0631	-0.1351	-0.1599	-0.1894	-0.5038
0.925	*****	-0.1228	-0.1576	-0.2027	-0.9140
0.950	-0.0251	-0.0987	-0.1478	-0.1967	-0.5673
0.975	*****	-0.0602	-0.1111	-0.1650	-0.3659
1.000	0.1582	0.1312	0.1087	0.0733	0.0485
	$C_{p,l}$	$C_{p,l}$	$C_{p,l}$	$C_{p,l}$	$C_{p,l}$
-0.200	0.0106	0.0261	0.0683	*****	-0.3036
-0.400	-0.0072	0.0284	0.0349	-0.0571	-0.3234
-0.600	-0.0162	0.0118	0.0188	-0.0479	-0.3326
-0.700	-0.0090	-0.0100	0.0079	-0.0447	-0.3457
-0.800	0.0138	*****	-0.0181	-0.0474	-0.3508
-0.850	*****	-0.0102	-0.0290	-0.0638	-0.4004
-0.900	*****	0.0140	-0.0230	-0.0723	-0.4913
-0.950	0.1238	0.0704	0.0342	-0.0327	-0.4133
-0.975	*****	0.1329	0.0862	0.0431	-0.2103
-1.000	0.1595	0.1367	0.0994	0.1091	0.0683

Medium Radius L.E.

Run No. = 21, Point No. = 410

$C_N = 0.054$, $C_m = -0.0101$

$\alpha = 1.8^\circ$, $M_\infty = 0.397$

$R_{mac} = 61.5 \times 10^6$

Leading Edge Pressures

● starboard
○ port

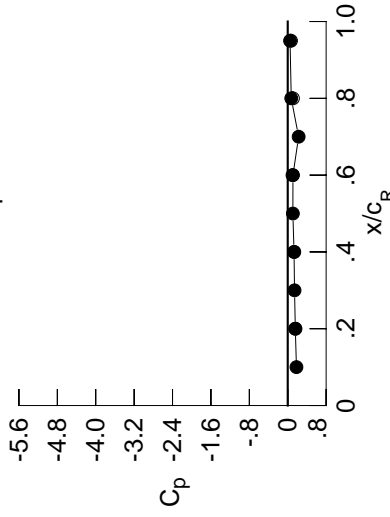

x/c_R	starb'd C_p	port C_p
0.10	0.1814	*****
0.20	0.1582	0.1595
0.30	0.1416	*****
0.40	0.1312	0.1367
0.50	0.1072	*****
0.60	0.1087	0.0994
0.70	0.2269	*****
0.80	0.0733	0.1091
0.90	*****	*****
0.95	0.0485	0.0683

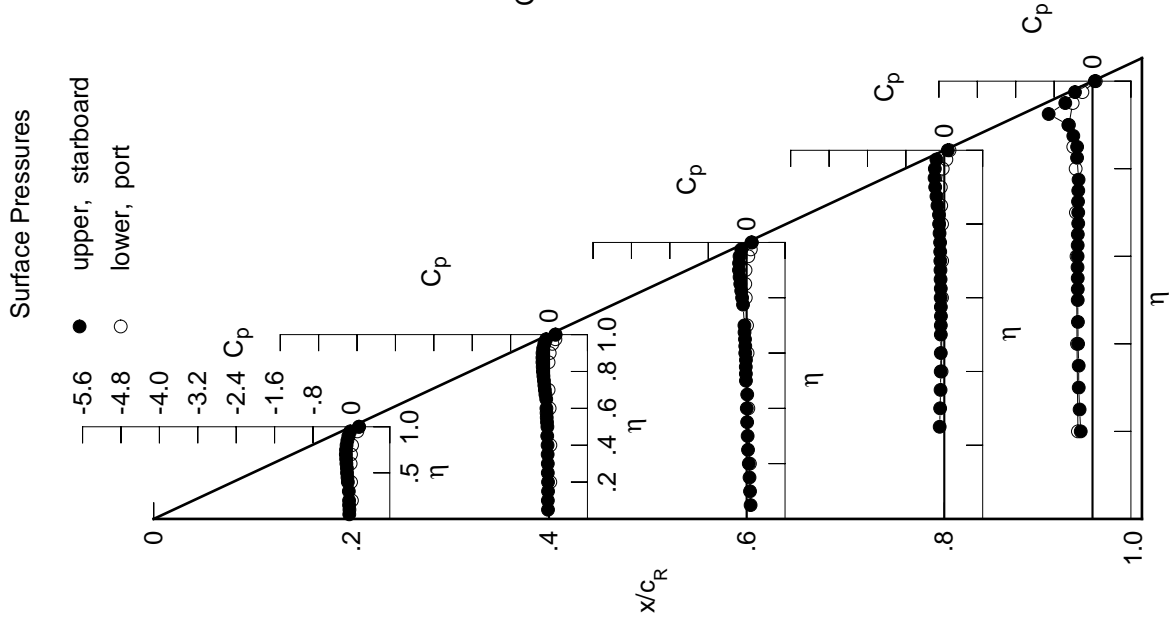

Table C2. Continued.

η	$x/c_R = .2$		$x/c_R = .4$		$x/c_R = .6$		$x/c_R = .8$		$x/c_R = .95$	
	$C_{p,u}$	$C_{p,u}$	$C_{p,u}$	$C_{p,u}$	$C_{p,u}$	$C_{p,u}$	$C_{p,u}$	$C_{p,u}$	$C_{p,u}$	$C_{p,u}$
0.050	-0.0658	-0.0396	0.0687	*****	*****	*****	*****	*****	*****	
0.100	-0.0622	-0.0419	0.0576	*****	*****	*****	*****	*****	*****	
0.150	-0.0692	-0.0385	0.0461	*****	*****	*****	*****	*****	*****	
0.200	-0.0705	-0.0393	0.0297	*****	*****	*****	*****	*****	*****	
0.250	*****	-0.0443	0.0149	-0.1025	-0.2655	-0.2445	-0.2445	-0.2445	-0.2445	
0.300	-0.0773	-0.0442	0.0075	-0.0942	-0.2797	-0.2655	-0.2655	-0.2655	-0.2655	
0.350	*****	-0.0487	-0.0056	-0.0874	-0.2814	-0.2797	-0.2797	-0.2797	-0.2797	
0.400	-0.0984	-0.0511	-0.0107	-0.0833	-0.2923	-0.2814	-0.2814	-0.2814	-0.2814	
0.450	-0.1087	-0.0590	-0.0058	-0.0827	-0.2977	-0.2923	-0.2923	-0.2923	-0.2923	
0.500	-0.1189	-0.0575	-0.0303	-0.0820	-0.3000	-0.2977	-0.2977	-0.2977	-0.2977	
0.525	*****	-0.0651	-0.0343	-0.0835	-0.3018	-0.3000	-0.3000	-0.3000	-0.3000	
0.550	-0.1244	-0.0721	-0.0353	-0.0826	-0.3004	-0.3018	-0.3018	-0.3018	-0.3018	
0.575	*****	-0.0763	-0.0326	-0.0833	-0.3047	-0.3004	-0.3004	-0.3004	-0.3004	
0.600	-0.1377	-0.0811	-0.0483	-0.0869	-0.3033	-0.3047	-0.3047	-0.3047	-0.3047	
0.625	*****	*****	-0.0493	-0.0850	-0.3020	-0.3033	-0.3033	-0.3033	-0.3033	
0.650	-0.1467	-0.0859	-0.0554	-0.0902	-0.3019	-0.3020	-0.3020	-0.3020	-0.3020	
0.675	*****	-0.1045	-0.0654	-0.0947	-0.2922	-0.3019	-0.3019	-0.3019	-0.3019	
0.700	-0.1548	-0.1170	-0.0699	-0.0970	-0.2943	-0.2922	-0.2922	-0.2922	-0.2922	
0.725	*****	-0.1313	*****	-0.1015	-0.2964	-0.2943	-0.2943	-0.2943	-0.2943	
0.750	-0.1565	-0.1434	*****	-0.1061	-0.2918	-0.2964	-0.2964	-0.2964	-0.2964	
0.775	*****	-0.1601	-0.1051	-0.1189	-0.2839	-0.2918	-0.2918	-0.2918	-0.2918	
0.800	-0.1499	-0.1721	-0.1283	-0.1313	*****	-0.2839	-0.2839	-0.2839	-0.2839	
0.825	*****	-0.1814	-0.1492	-0.1364	-0.3194	*****	*****	*****	*****	
0.850	-0.1378	-0.1899	-0.1753	-0.1738	-0.3210	-0.3194	-0.3194	-0.3194	-0.3194	
0.875	*****	-0.1968	-0.1975	-0.2000	-0.4062	-0.3210	-0.3210	-0.3210	-0.3210	
0.900	-0.1233	-0.1994	-0.2188	-0.2367	-0.5166	-0.4062	-0.4062	-0.4062	-0.4062	
0.925	*****	-0.1955	-0.2272	-0.2600	-0.9467	-0.5166	-0.5166	-0.5166	-0.5166	
0.950	-0.0968	-0.1807	-0.2296	-0.2691	-0.6000	-0.9467	-0.9467	-0.9467	-0.9467	
0.975	*****	-0.1606	-0.2130	-0.2541	-0.4046	-0.6000	-0.6000	-0.6000	-0.6000	
1.000	0.0829	0.0127	-0.0239	-0.0727	-0.0238	-0.4046	-0.4046	-0.4046	-0.4046	
-0.200	$C_{p,l}$	$C_{p,l}$	$C_{p,l}$	$C_{p,l}$	$C_{p,l}$	$C_{p,l}$	$C_{p,l}$	$C_{p,l}$	$C_{p,l}$	
-0.400	0.0313	0.0405	0.0783	*****	*****	-0.3085	-0.3085	-0.3085	-0.3085	
-0.600	0.0157	0.0463	0.0480	-0.0510	-0.3317	*****	*****	*****	*****	
-0.700	0.0119	0.0342	0.0347	-0.0373	-0.3398	-0.3317	-0.3317	-0.3317	-0.3317	
-0.800	0.0239	0.0169	0.0293	-0.0320	-0.3523	-0.3398	-0.3398	-0.3398	-0.3398	
-0.850	0.0505	*****	0.0092	-0.0289	-0.3571	-0.3523	-0.3523	-0.3523	-0.3523	
-0.900	*****	0.0299	0.0052	-0.0395	-0.4029	-0.3571	-0.3571	-0.3571	-0.3571	
-0.950	*****	0.0581	0.0183	-0.0380	-0.4810	-0.4029	-0.4029	-0.4029	-0.4029	
-0.975	0.1599	0.1145	0.0797	0.0116	-0.3727	-0.4810	-0.4810	-0.4810	-0.4810	
-1.000	*****	0.1702	0.1289	0.0860	-0.1646	-0.3727	-0.3727	-0.3727	-0.3727	
	0.0822	0.0247	-0.0376	-0.0206	-0.0045	-0.1646	-0.1646	-0.1646	-0.1646	

Medium Radius L.E.
 Run No. = 21, Point No. = 411
 $C_N = 0.093$, $C_m = -0.0170$
 $\alpha = 2.9^\circ$, $M_\infty = 0.398$
 $R_{mac} = 60.6 \times 10^6$

Leading Edge Pressures

● starboard
 ○ port

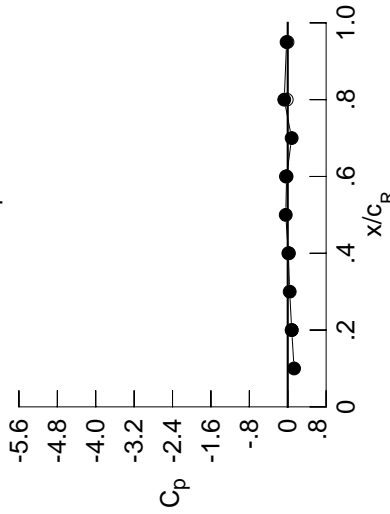

x/c_R	starb'd C_p	port C_p
0.10	0.1324	*****
0.20	0.0829	0.0822
0.30	0.0406	*****
0.40	0.0127	0.0247
0.50	-0.0418	*****
0.60	-0.0239	-0.0376
0.70	0.0814	*****
0.80	-0.0727	-0.0206
0.90	*****	*****
0.95	-0.0238	-0.0045

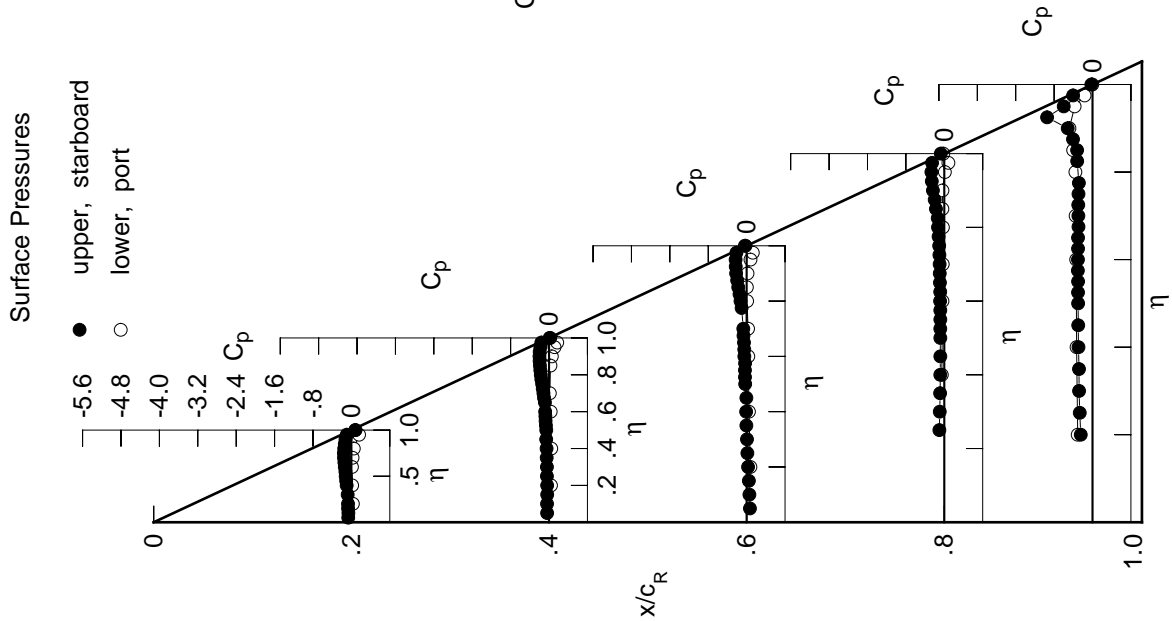

Table C2. Continued.

η	$x/c_R = .2$		$x/c_R = .4$		$x/c_R = .6$		$x/c_R = .8$		$x/c_R = .95$	
	$C_{p,u}$	$C_{p,u}$	$C_{p,u}$	$C_{p,u}$	$C_{p,u}$	$C_{p,u}$	$C_{p,u}$	$C_{p,u}$	$C_{p,u}$	$C_{p,u}$
0.050	-0.0838	-0.0543	0.0601	*****	*****	*****	*****	*****	*****	*****
0.100	-0.0811	-0.0552	0.0490	*****	*****	*****	*****	*****	*****	*****
0.150	-0.0890	-0.0530	0.0354	*****	*****	*****	*****	*****	*****	*****
0.200	-0.0895	-0.0536	0.0199	*****	*****	*****	*****	*****	*****	*****
0.250	*****	-0.0584	0.0045	-0.1093	-0.2608	*****	*****	*****	*****	*****
0.300	-0.0974	-0.0612	-0.0037	-0.1003	-0.2754	*****	*****	*****	*****	*****
0.350	*****	-0.0651	-0.0172	-0.0930	-0.2749	*****	*****	*****	*****	*****
0.400	-0.1209	-0.0688	-0.0241	-0.0899	-0.2890	*****	*****	*****	*****	*****
0.450	-0.1329	-0.0760	-0.0187	-0.0904	-0.2911	*****	*****	*****	*****	*****
0.500	-0.1463	-0.0772	-0.0434	-0.0910	-0.2952	*****	*****	*****	*****	*****
0.525	*****	-0.0846	-0.0489	-0.0912	-0.2956	*****	*****	*****	*****	*****
0.550	-0.1543	-0.0939	-0.0512	-0.0913	-0.2961	*****	*****	*****	*****	*****
0.575	*****	-0.0982	-0.0495	-0.0932	-0.2992	*****	*****	*****	*****	*****
0.600	-0.1710	-0.1047	-0.0652	-0.0984	-0.2991	*****	*****	*****	*****	*****
0.625	*****	*****	-0.0669	-0.0967	-0.2983	*****	*****	*****	*****	*****
0.650	-0.1823	-0.1121	-0.0748	-0.1015	-0.2964	*****	*****	*****	*****	*****
0.675	*****	-0.1314	-0.0848	-0.1074	-0.2884	*****	*****	*****	*****	*****
0.700	-0.1955	-0.1474	-0.0910	-0.1118	-0.2897	*****	*****	*****	*****	*****
0.725	*****	-0.1635	*****	-0.1173	-0.2908	*****	*****	*****	*****	*****
0.750	-0.1992	-0.1786	*****	-0.1231	-0.2835	*****	*****	*****	*****	*****
0.775	*****	-0.1976	-0.1338	-0.1389	-0.2754	*****	*****	*****	*****	*****
0.800	-0.1983	-0.2162	-0.1608	-0.1552	*****	*****	*****	*****	*****	*****
0.825	*****	-0.2287	-0.1868	-0.1612	-0.3117	*****	*****	*****	*****	*****
0.850	-0.1921	-0.2428	-0.2185	-0.2045	-0.3172	*****	*****	*****	*****	*****
0.875	*****	-0.2552	-0.2490	-0.2381	-0.4064	*****	*****	*****	*****	*****
0.900	-0.1867	-0.2649	-0.2770	-0.2837	-0.5245	*****	*****	*****	*****	*****
0.925	*****	-0.2688	-0.2952	-0.3184	-0.9737	*****	*****	*****	*****	*****
0.950	-0.1725	-0.2654	-0.3146	-0.3414	-0.6362	*****	*****	*****	*****	*****
0.975	*****	-0.2691	-0.3209	-0.3541	-0.4645	*****	*****	*****	*****	*****
1.000	-0.0200	-0.1484	-0.2045	-0.2817	-0.1504	*****	*****	*****	*****	*****
	$C_{p,l}$	$C_{p,l}$	$C_{p,l}$	$C_{p,l}$	$C_{p,l}$	$C_{p,l}$	$C_{p,l}$	$C_{p,l}$	$C_{p,l}$	$C_{p,l}$
-0.200	0.0515	0.0582	0.0912	*****	*****	*****	*****	*****	*****	*****
-0.400	0.0382	0.0631	0.0599	-0.0421	-0.3391	*****	*****	*****	*****	*****
-0.600	0.0389	0.0539	0.0510	-0.0276	-0.3484	*****	*****	*****	*****	*****
-0.700	0.0533	0.0412	0.0469	-0.0208	-0.3593	*****	*****	*****	*****	*****
-0.800	0.0830	*****	0.0337	-0.0119	-0.3645	*****	*****	*****	*****	*****
-0.850	*****	0.0636	0.0342	-0.0172	-0.4073	*****	*****	*****	*****	*****
-0.900	*****	0.0941	0.0538	-0.0083	-0.4757	*****	*****	*****	*****	*****
-0.950	0.1845	0.1482	0.1158	0.0485	-0.3389	*****	*****	*****	*****	*****
-0.975	*****	0.1905	0.1579	0.1191	-0.1277	*****	*****	*****	*****	*****
-1.000	-0.0282	-0.1246	-0.2367	-0.2144	-0.1131	*****	*****	*****	*****	*****

Medium Radius L.E.
 Run No. = 21, Point No. = 412
 $C_N = 0.123$, $C_m = -0.0173$
 $\alpha = 3.9^\circ$, $M_\infty = 0.398$
 $R_{mac} = 60.4 \times 10^6$

Leading Edge Pressures

- starboard
- port

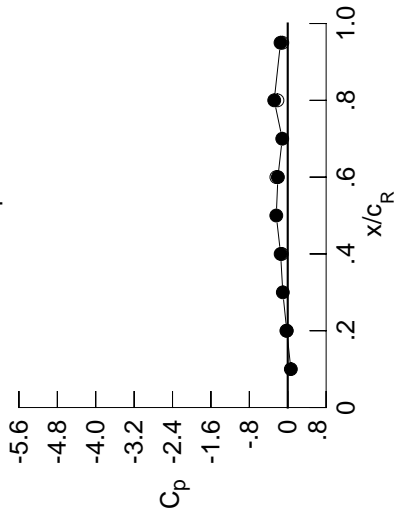

x/c_R	starb'd C_p	port C_p
0.10	0.0649	*****
0.20	-0.0200	-0.0282
0.30	-0.1025	*****
0.40	-0.1484	-0.1246
0.50	-0.2388	*****
0.60	-0.2045	-0.2367
0.70	-0.1142	*****
0.80	-0.2817	-0.2144
0.90	*****	*****
0.95	-0.1504	-0.1131

Surface Pressures

- upper, starboard
- lower, port

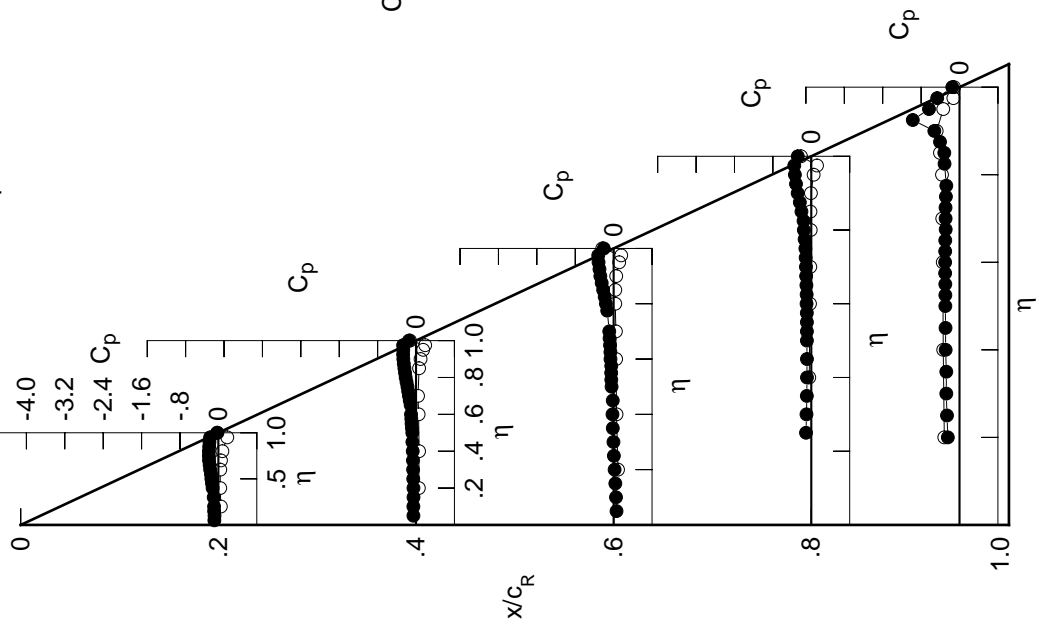

Table C2. Continued.

η	$x/c_R = .2$		$x/c_R = .4$		$x/c_R = .6$		$x/c_R = .8$		$x/c_R = .95$	
	$C_{p,u}$	$C_{p,l}$	$C_{p,u}$	$C_{p,l}$	$C_{p,u}$	$C_{p,l}$	$C_{p,u}$	$C_{p,l}$	$C_{p,u}$	$C_{p,l}$
0.050	-0.0982	-0.0643	0.0529	*****	*****	*****	*****	*****	*****	*****
0.100	-0.0967	-0.0679	0.0409	*****	*****	*****	*****	*****	*****	*****
0.150	-0.1031	-0.0666	0.0293	*****	*****	*****	*****	*****	*****	*****
0.200	-0.1062	-0.0664	0.0114	*****	*****	*****	*****	*****	*****	*****
0.250	*****	-0.0714	-0.0017	-0.1133	-0.2527	*****	*****	*****	*****	*****
0.300	-0.1149	-0.0734	-0.0138	-0.1041	-0.2666	*****	*****	*****	*****	*****
0.350	*****	-0.0776	-0.0259	-0.0979	-0.2663	*****	*****	*****	*****	*****
0.400	-0.1407	-0.0827	-0.0344	-0.0944	-0.2777	*****	*****	*****	*****	*****
0.450	-0.1559	-0.0916	-0.0284	-0.0941	-0.2815	*****	*****	*****	*****	*****
0.500	-0.1700	-0.0932	-0.0561	-0.0957	-0.2854	*****	*****	*****	*****	*****
0.525	*****	-0.1030	-0.0608	-0.0981	-0.2858	*****	*****	*****	*****	*****
0.550	-0.1796	-0.1118	-0.0638	-0.0980	-0.2844	*****	*****	*****	*****	*****
0.575	*****	-0.1179	-0.0621	-0.1013	-0.2891	*****	*****	*****	*****	*****
0.600	-0.1992	-0.1238	-0.0788	-0.1053	-0.2880	*****	*****	*****	*****	*****
0.625	*****	*****	-0.0817	-0.1062	-0.2868	*****	*****	*****	*****	*****
0.650	-0.2144	-0.1347	-0.0913	-0.1108	-0.2865	*****	*****	*****	*****	*****
0.675	*****	-0.1552	-0.1026	-0.1188	-0.2774	*****	*****	*****	*****	*****
0.700	-0.2310	-0.1748	-0.1128	-0.1221	-0.2778	*****	*****	*****	*****	*****
0.725	*****	-0.1913	*****	-0.1314	-0.2790	*****	*****	*****	*****	*****
0.750	-0.2404	-0.2115	*****	-0.1382	-0.2714	*****	*****	*****	*****	*****
0.775	*****	-0.2344	-0.1604	-0.1564	-0.2595	*****	*****	*****	*****	*****
0.800	-0.2442	-0.2551	-0.1899	-0.1744	*****	*****	*****	*****	*****	*****
0.825	*****	-0.2729	-0.2224	-0.1848	-0.2921	*****	*****	*****	*****	*****
0.850	-0.2448	-0.2927	-0.2586	-0.2324	-0.3033	*****	*****	*****	*****	*****
0.875	*****	-0.3129	-0.2964	-0.2740	-0.3975	*****	*****	*****	*****	*****
0.900	-0.2491	-0.3292	-0.3356	-0.3283	-0.5218	*****	*****	*****	*****	*****
0.925	*****	-0.3449	-0.3674	-0.3761	-0.9853	*****	*****	*****	*****	*****
0.950	-0.2512	-0.3540	-0.4001	-0.4170	-0.6659	*****	*****	*****	*****	*****
0.975	*****	-0.3872	-0.4394	-0.4577	-0.5209	*****	*****	*****	*****	*****
1.000	-0.1562	-0.3633	-0.4474	-0.5699	-0.3131	*****	*****	*****	*****	*****
-0.200	0.0714	0.0744	0.1036	*****	-0.3161	*****	*****	*****	*****	*****
-0.400	0.0601	0.0807	0.0737	-0.0336	-0.3404	*****	*****	*****	*****	*****
-0.600	0.0667	0.0756	0.0678	-0.0159	-0.3529	*****	*****	*****	*****	*****
-0.700	0.0835	0.0656	0.0656	-0.0062	-0.3646	*****	*****	*****	*****	*****
-0.800	0.1137	*****	0.0578	0.0052	-0.3687	*****	*****	*****	*****	*****
-0.850	*****	0.0957	0.0629	0.0065	-0.4075	*****	*****	*****	*****	*****
-0.900	*****	0.1266	0.0867	0.0228	-0.4643	*****	*****	*****	*****	*****
-0.950	0.2037	0.1738	0.1458	0.0826	-0.3049	*****	*****	*****	*****	*****
-0.975	*****	0.2021	0.1757	0.1425	-0.0944	*****	*****	*****	*****	*****
-1.000	-0.1708	-0.3191	-0.5041	-0.4735	-0.2559	*****	*****	*****	*****	*****

Medium Radius L.E.

Run No. = 21, Point No. = 413

$C_N = 0.156$, $C_m = -0.0210$

$\alpha = 4.9^\circ$, $M_\infty = 0.398$

$R_{mac} = 60.3 \times 10^6$

Leading Edge Pressures

● starboard
○ port

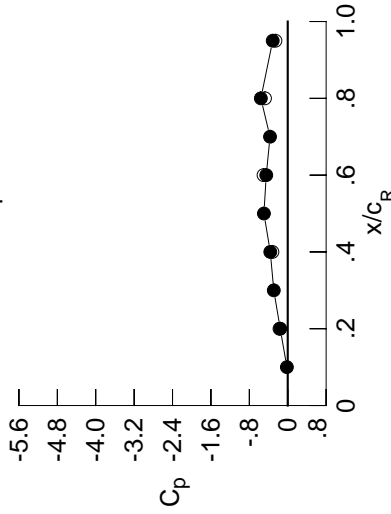

x/c_R	starb'd C_p	port C_p
0.10	-0.0175	*****
0.20	-0.1562	-0.1708
0.30	-0.2907	*****
0.40	-0.3633	-0.3191
0.50	-0.4959	*****
0.60	-0.4474	-0.5041
0.70	-0.3690	*****
0.80	-0.5599	-0.4735
0.90	*****	*****
0.95	-0.3131	-0.2559

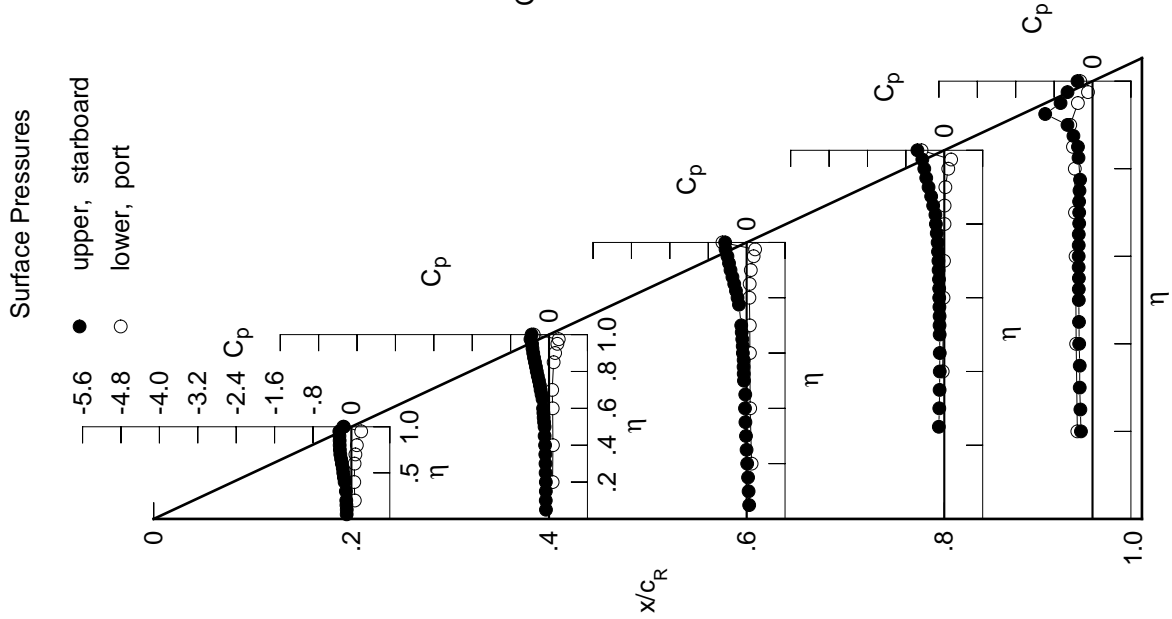
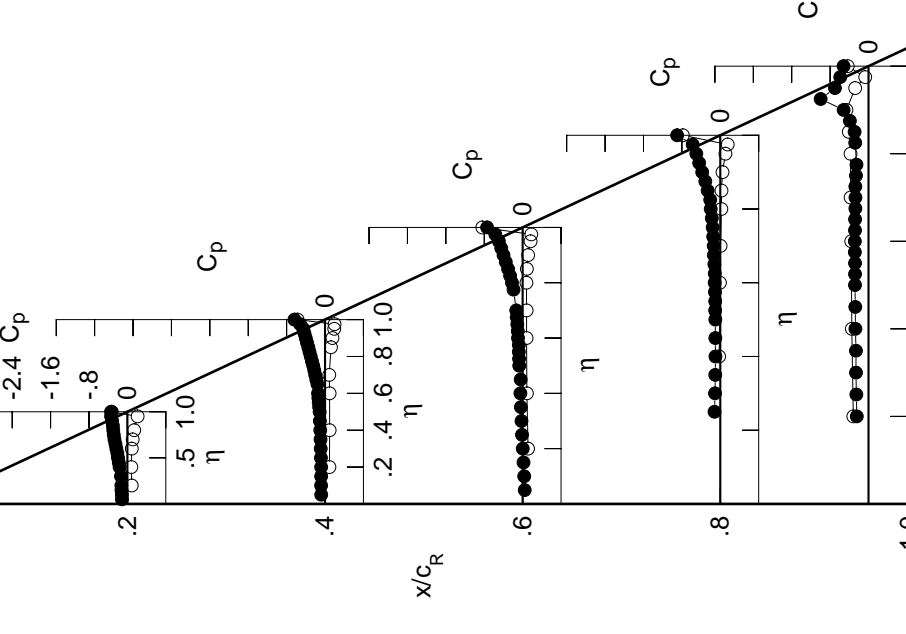
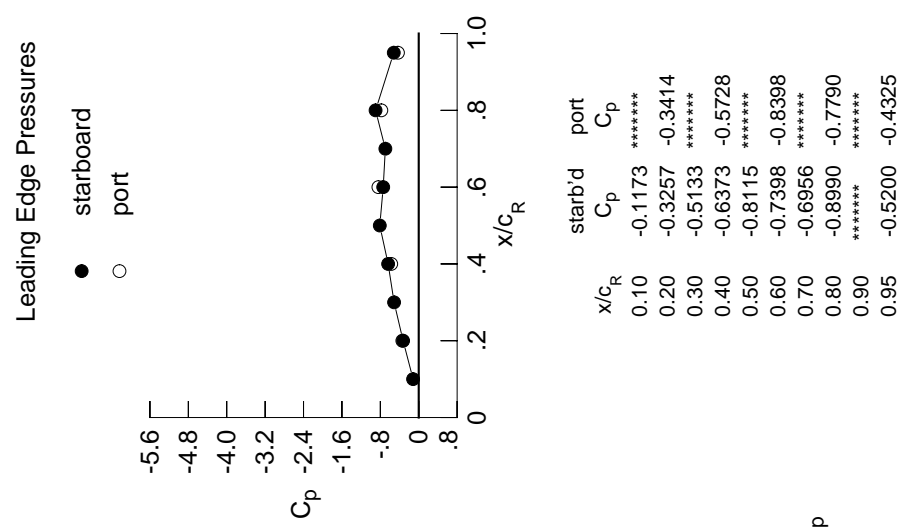

Table C2. Continued.

η	$x/c_R = .2$		$x/c_R = .4$		$x/c_R = .6$		$x/c_R = .8$		$x/c_R = .95$	
	$C_{p,u}$	$C_{p,u}$	$C_{p,u}$	$C_{p,u}$	$C_{p,u}$	$C_{p,u}$	$C_{p,u}$	$C_{p,u}$	$C_{p,u}$	$C_{p,u}$
0.050	-0.1133	-0.0790	0.0433	*****	*****	*****	*****	*****	*****	
0.100	-0.1144	-0.0817	0.0327	*****	*****	*****	*****	*****	*****	
0.150	-0.1231	-0.0806	0.0187	*****	*****	*****	*****	*****	*****	
0.200	-0.1254	-0.0805	0.0021	*****	*****	*****	*****	*****	*****	
0.250	*****	-0.0857	-0.0131	*****	*****	*****	*****	*****	-0.2438	
0.300	-0.1347	-0.0899	-0.0240	-0.1198	-0.1100	-0.2607	*****	*****	-0.2539	
0.350	*****	-0.0940	-0.0368	-0.1047	-0.2613	*****	*****	*****	-0.2607	
0.400	-0.1630	-0.0996	-0.0464	-0.1009	-0.2727	*****	*****	*****	-0.2613	
0.450	-0.1792	-0.1083	-0.0411	-0.1034	-0.2753	*****	*****	*****	-0.2727	
0.500	-0.1956	-0.1128	-0.0710	-0.1036	-0.2813	*****	*****	*****	-0.2753	
0.525	*****	-0.1222	-0.0747	-0.1072	-0.2807	*****	*****	*****	-0.2813	
0.550	-0.2089	-0.1315	-0.0794	-0.1059	-0.2805	*****	*****	*****	-0.2807	
0.575	*****	-0.1395	-0.0790	-0.1109	-0.2843	*****	*****	*****	-0.2805	
0.600	-0.2303	-0.1456	-0.0958	-0.1166	-0.2845	*****	*****	*****	-0.2843	
0.625	*****	*****	-0.1010	-0.1148	-0.2817	*****	*****	*****	-0.2845	
0.650	-0.2487	-0.1587	-0.1109	-0.1228	-0.2802	*****	*****	*****	-0.2817	
0.675	*****	-0.1816	-0.1234	-0.1333	-0.2733	*****	*****	*****	-0.2802	
0.700	-0.2694	-0.2040	-0.1327	-0.1368	-0.2723	*****	*****	*****	-0.2733	
0.725	*****	-0.2242	*****	-0.1477	-0.2741	*****	*****	*****	-0.2723	
0.750	-0.2837	-0.2467	*****	-0.1587	-0.2618	*****	*****	*****	-0.2741	
0.775	*****	-0.2733	-0.1895	-0.1767	-0.2503	*****	*****	*****	-0.2618	
0.800	-0.2944	-0.2985	-0.2222	-0.1989	*****	*****	*****	*****	-0.2503	
0.825	*****	-0.3244	-0.2609	-0.2097	-0.2767	*****	*****	*****	-0.1989	
0.850	-0.3027	-0.3474	-0.3029	-0.2629	-0.2893	*****	*****	*****	-0.2767	
0.875	*****	-0.3762	-0.3512	-0.3118	-0.3883	*****	*****	*****	-0.3029	
0.900	-0.3184	-0.4012	-0.3981	-0.3772	-0.5188	*****	*****	*****	-0.3118	
0.925	*****	-0.4282	-0.4452	-0.4400	-0.9968	*****	*****	*****	-0.3981	
0.950	-0.3401	-0.4520	-0.4956	-0.4992	-0.6995	*****	*****	*****	-0.4400	
0.975	*****	-0.5182	-0.5689	-0.5750	-0.5885	*****	*****	*****	-0.4992	
1.000	-0.3257	-0.6373	-0.7398	-0.8990	-0.5200	*****	*****	*****	-0.5750	
-0.200	$C_{p,l}$	$C_{p,l}$	$C_{p,l}$	$C_{p,l}$	$C_{p,l}$	$C_{p,l}$	$C_{p,l}$	$C_{p,l}$	$C_{p,l}$	
-0.400	0.0904	0.0913	0.1131	*****	-0.3169	*****	*****	*****	-0.3169	
-0.600	0.0820	0.0963	0.0887	-0.0238	-0.3482	*****	*****	*****	-0.3169	
-0.700	0.0918	0.0949	0.0814	-0.0070	-0.3600	*****	*****	*****	-0.3482	
-0.800	0.1104	0.0884	0.0826	0.0065	-0.3726	*****	*****	*****	-0.3600	
-0.850	0.1421	*****	0.0791	0.0221	-0.3741	*****	*****	*****	-0.3726	
-0.900	*****	0.1239	0.0876	0.0248	-0.4108	*****	*****	*****	-0.3741	
-0.950	*****	0.1546	0.1145	0.0462	-0.4590	*****	*****	*****	-0.4108	
-0.975	0.2132	0.1920	0.1660	0.1071	-0.2773	*****	*****	*****	-0.4590	
-1.000	*****	0.1987	0.1802	0.1548	-0.0689	*****	*****	*****	-0.1071	
	-0.3414	-0.5728	-0.8398	-0.7790	-0.4325	*****	*****	*****	-0.1548	

Medium Radius L.E.
 Run No. = 21, Point No. = 414
 $C_N = 0.194$, $C_m = -0.0274$
 $\alpha = 6.0^\circ$, $M_\infty = 0.398$
 $R_{mac} = 60.0 \times 10^6$



x/c_R	starb'd C_p	port C_p
0.10	-0.1173	*****
0.20	-0.3257	-0.3414
0.30	-0.5133	*****
0.40	-0.6373	-0.5728
0.50	-0.8115	*****
0.60	-0.7398	-0.8398
0.70	-0.6956	*****
0.80	-0.8990	-0.7790
0.90	*****	*****
0.95	-0.5200	-0.4325

Table C2. Continued.

η	$x/c_R = .2$		$x/c_R = .4$		$x/c_R = .6$		$x/c_R = .8$		$x/c_R = .95$	
	$C_{p,u}$	$C_{p,l}$	$C_{p,u}$	$C_{p,l}$	$C_{p,u}$	$C_{p,l}$	$C_{p,u}$	$C_{p,l}$	$C_{p,u}$	$C_{p,l}$
0.050	-0.1276	-0.0887	0.0372	*****	*****	*****	*****	*****	*****	*****
0.100	-0.1298	-0.0921	0.0241	*****	*****	*****	*****	*****	*****	*****
0.150	-0.1372	-0.0902	0.0115	*****	*****	*****	*****	*****	*****	*****
0.200	-0.1411	-0.0916	-0.0044	*****	*****	*****	*****	*****	*****	*****
0.250	*****	-0.0978	-0.0212	-0.1216	-0.1216	-0.1216	-0.1216	-0.2456	-0.2456	-0.2456
0.300	-0.1517	-0.1012	-0.0320	-0.1137	-0.1137	-0.1137	-0.1137	-0.2567	-0.2567	-0.2567
0.350	*****	-0.1073	-0.0471	-0.1082	-0.1082	-0.1082	-0.1082	-0.2546	-0.2546	-0.2546
0.400	-0.1821	-0.1139	-0.0542	-0.1052	-0.1052	-0.1052	-0.1052	-0.2652	-0.2652	-0.2652
0.450	-0.1992	-0.1247	-0.0528	-0.1071	-0.1071	-0.1071	-0.1071	-0.2672	-0.2672	-0.2672
0.500	-0.2176	-0.1298	-0.0817	-0.1111	-0.1111	-0.1111	-0.1111	-0.2735	-0.2735	-0.2735
0.525	*****	-0.1402	-0.0869	-0.1131	-0.1131	-0.1131	-0.1131	-0.2731	-0.2731	-0.2731
0.550	-0.2345	-0.1509	-0.0915	-0.1154	-0.1154	-0.1154	-0.1154	-0.2731	-0.2731	-0.2731
0.575	*****	-0.1590	-0.0934	-0.1179	-0.1179	-0.1179	-0.1179	-0.2755	-0.2755	-0.2755
0.600	-0.2584	-0.1661	-0.1105	-0.1255	-0.1255	-0.1255	-0.1255	-0.2763	-0.2763	-0.2763
0.625	*****	*****	-0.1184	-0.1265	-0.1265	-0.1265	-0.1265	-0.2752	-0.2752	-0.2752
0.650	-0.2814	-0.1830	-0.1270	-0.1352	-0.1352	-0.1352	-0.1352	-0.2739	-0.2739	-0.2739
0.675	*****	-0.2066	-0.1416	-0.1435	-0.1435	-0.1435	-0.1435	-0.2650	-0.2650	-0.2650
0.700	-0.3060	-0.2302	-0.1527	-0.1517	-0.1517	-0.1517	-0.1517	-0.2677	-0.2677	-0.2677
0.725	*****	-0.2544	*****	-0.1624	-0.1624	-0.1624	-0.1624	-0.2681	-0.2681	-0.2681
0.750	-0.3260	-0.2795	*****	-0.1746	-0.1746	-0.1746	-0.1746	-0.2609	-0.2609	-0.2609
0.775	*****	-0.3087	-0.2158	-0.1971	-0.1971	-0.1971	-0.1971	-0.2487	-0.2487	-0.2487
0.800	-0.3431	-0.3405	-0.2542	-0.2190	-0.2190	-0.2190	-0.2190	*****	*****	*****
0.825	*****	-0.3695	-0.2941	-0.2338	-0.2338	-0.2338	-0.2338	-0.2674	-0.2674	-0.2674
0.850	-0.3607	-0.4021	-0.3472	-0.2905	-0.2905	-0.2905	-0.2905	-0.2782	-0.2782	-0.2782
0.875	*****	-0.4359	-0.3994	-0.3480	-0.3480	-0.3480	-0.3480	-0.3748	-0.3748	-0.3748
0.900	-0.3880	-0.4719	-0.4614	-0.4235	-0.4235	-0.4235	-0.4235	-0.5131	-0.5131	-0.5131
0.925	*****	-0.5106	-0.5182	-0.5016	-0.5016	-0.5016	-0.5016	-0.9998	-0.9998	-0.9998
0.950	-0.4316	-0.5546	-0.5933	-0.5811	-0.5811	-0.5811	-0.5811	-0.7329	-0.7329	-0.7329
0.975	*****	-0.6560	-0.7028	-0.6951	-0.6951	-0.6951	-0.6951	-0.6522	-0.6522	-0.6522
1.000	-0.5255	-0.9707	-1.0827	-1.2928	-1.2928	-1.2928	-1.2928	-0.7585	-0.7585	-0.7585
-0.200	$C_{p,l}$	$C_{p,l}$	$C_{p,l}$	$C_{p,l}$	$C_{p,l}$	$C_{p,l}$	$C_{p,l}$	$C_{p,l}$	$C_{p,l}$	$C_{p,l}$
-0.400	0.1119	0.1092	0.1286	*****	*****	*****	*****	-0.3186	-0.3186	-0.3186
-0.600	0.1056	0.1152	0.1033	-0.1033	-0.1033	-0.1033	-0.1033	-0.3488	-0.3488	-0.3488
-0.700	0.1187	0.1160	0.0989	0.0060	-0.0060	-0.0060	-0.0060	-0.3648	-0.3648	-0.3648
-0.800	0.1385	0.1137	0.1018	0.0194	-0.0194	-0.0194	-0.0194	-0.3761	-0.3761	-0.3761
-0.850	0.1689	*****	0.1034	0.0415	-0.0415	-0.0415	-0.0415	-0.3781	-0.3781	-0.3781
-0.900	*****	0.1516	0.1143	0.0464	-0.0464	-0.0464	-0.0464	-0.4082	-0.4082	-0.4082
-0.950	0.2176	0.2023	0.1828	0.1414	0.0721	-0.0721	-0.0721	-0.4460	-0.4460	-0.4460
-0.975	*****	0.1851	0.1751	0.1602	-0.1602	-0.1602	-0.1602	-0.2468	-0.2468	-0.2468
-1.000	-0.5487	-0.8820	-1.2462	-1.1736	-1.1736	-1.1736	-1.1736	-0.6474	-0.6474	-0.6474

Medium Radius L.E.
 Run No. = 21, Point No. = 415
 $C_N = 0.226$, $C_m = -0.0304$
 $\alpha = 7.0^\circ$, $M_\infty = 0.398$
 $R_{mac} = 60.0 \times 10^6$

Leading Edge Pressures

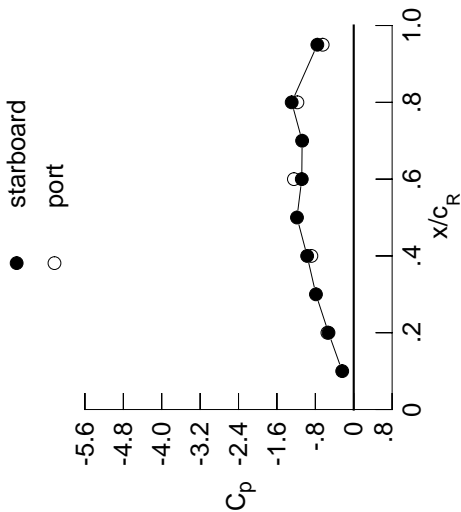

x/c_R	starb'd C_p	port C_p
0.10	-0.2399	*****
0.20	-0.5255	-0.5487
0.30	-0.7873	*****
0.40	-0.9707	-0.8820
0.50	-1.1820	*****
0.60	-1.0827	-1.2462
0.70	-1.0749	*****
0.80	-1.2928	-1.1736
0.90	*****	*****
0.95	-0.7585	-0.6474

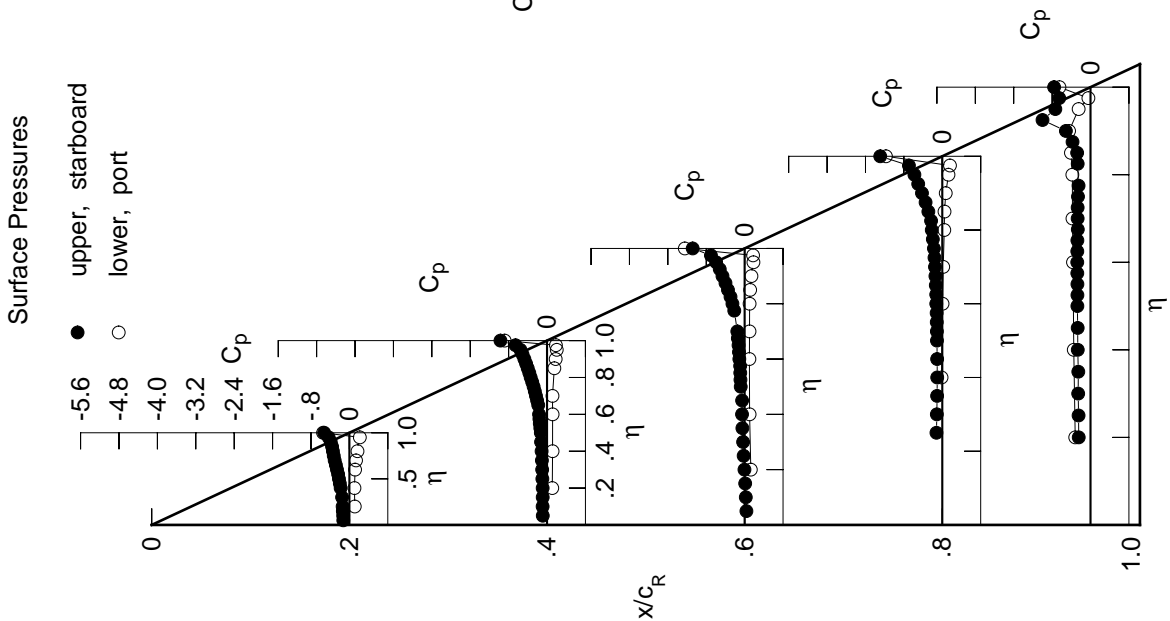
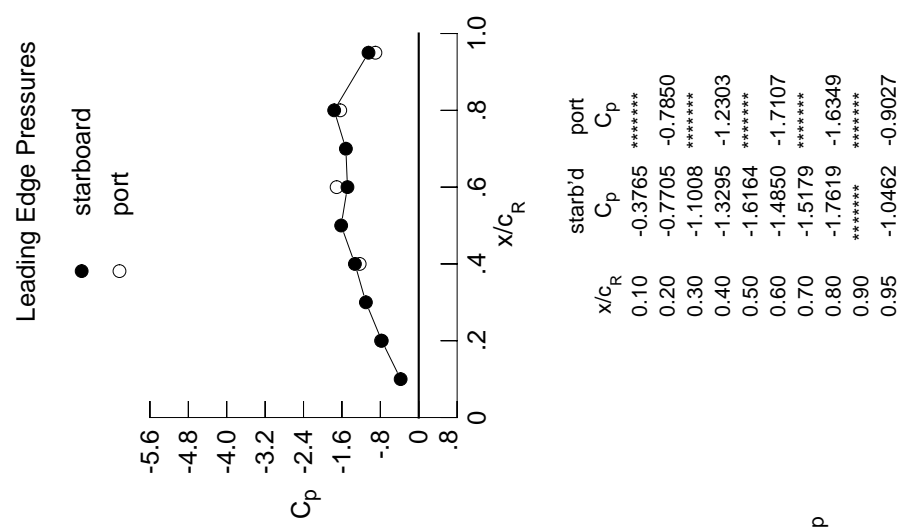

Table C2. Continued.

η	$x/c_R = .2$		$x/c_R = .4$		$x/c_R = .6$		$x/c_R = .8$		$x/c_R = .95$	
	$C_{p,u}$	$C_{p,u}$	$C_{p,u}$	$C_{p,u}$	$C_{p,u}$	$C_{p,u}$	$C_{p,u}$	$C_{p,u}$	$C_{p,u}$	$C_{p,u}$
0.050	-0.1410	-0.0995	0.0300	0.0300	0.0300	0.0300	0.0300	0.0300	0.0300	0.0300
0.100	-0.1450	-0.1037	0.0180	0.0180	0.0180	0.0180	0.0180	0.0180	0.0180	0.0180
0.150	-0.1543	-0.1027	0.0041	0.0041	0.0041	0.0041	0.0041	0.0041	0.0041	0.0041
0.200	-0.1581	-0.1042	-0.0120	-0.0120	-0.0120	-0.0120	-0.0120	-0.0120	-0.0120	-0.0120
0.250	*****	-0.1100	-0.0291	-0.1277	-0.1277	-0.1277	-0.1277	-0.1277	-0.1277	-0.1277
0.300	-0.1692	-0.1156	-0.0400	-0.1173	-0.1173	-0.1173	-0.1173	-0.1173	-0.1173	-0.1173
0.350	*****	-0.1204	-0.0542	-0.1142	-0.1142	-0.1142	-0.1142	-0.1142	-0.1142	-0.1142
0.400	-0.2014	-0.1296	-0.0656	-0.1116	-0.1116	-0.1116	-0.1116	-0.1116	-0.1116	-0.1116
0.450	-0.2204	-0.1404	-0.0647	-0.1136	-0.1136	-0.1136	-0.1136	-0.1136	-0.1136	-0.1136
0.500	-0.2416	-0.1471	-0.0941	-0.1177	-0.1177	-0.1177	-0.1177	-0.1177	-0.1177	-0.1177
0.525	*****	-0.1585	-0.1000	-0.1201	-0.1201	-0.1201	-0.1201	-0.1201	-0.1201	-0.1201
0.550	-0.2605	-0.1702	-0.1065	-0.1226	-0.1226	-0.1226	-0.1226	-0.1226	-0.1226	-0.1226
0.575	*****	-0.1781	-0.1069	-0.1299	-0.1299	-0.1299	-0.1299	-0.1299	-0.1299	-0.1299
0.600	-0.2882	-0.1887	-0.1272	-0.1352	-0.1352	-0.1352	-0.1352	-0.1352	-0.1352	-0.1352
0.625	*****	*****	-0.1332	-0.1358	-0.1358	-0.1358	-0.1358	-0.1358	-0.1358	-0.1358
0.650	-0.3160	-0.2076	-0.1470	-0.1473	-0.1473	-0.1473	-0.1473	-0.1473	-0.1473	-0.1473
0.675	*****	-0.2326	-0.1614	-0.1587	-0.1587	-0.1587	-0.1587	-0.1587	-0.1587	-0.1587
0.700	-0.3445	-0.2583	-0.1752	-0.1671	-0.1671	-0.1671	-0.1671	-0.1671	-0.1671	-0.1671
0.725	*****	-0.2852	*****	-0.1807	-0.1807	-0.1807	-0.1807	-0.1807	-0.1807	-0.1807
0.750	-0.3699	-0.3121	*****	-0.1952	-0.1952	-0.1952	-0.1952	-0.1952	-0.1952	-0.1952
0.775	*****	-0.3479	-0.2453	-0.2203	-0.2203	-0.2203	-0.2203	-0.2203	-0.2203	-0.2203
0.800	-0.3942	-0.3826	-0.2853	-0.2422	-0.2422	-0.2422	-0.2422	-0.2422	-0.2422	-0.2422
0.825	*****	-0.4206	-0.3317	-0.2601	-0.2601	-0.2601	-0.2601	-0.2601	-0.2601	-0.2601
0.850	-0.4214	-0.4570	-0.3896	-0.3210	-0.3210	-0.3210	-0.3210	-0.3210	-0.3210	-0.3210
0.875	*****	-0.5015	-0.4533	-0.3854	-0.3665	-0.3665	-0.3665	-0.3665	-0.3665	-0.3665
0.900	-0.4611	-0.5455	-0.5269	-0.4729	-0.4729	-0.4729	-0.4729	-0.4729	-0.4729	-0.4729
0.925	*****	-0.6003	-0.6007	-0.5648	-1.0039	-1.0039	-1.0039	-1.0039	-1.0039	-1.0039
0.950	-0.5308	-0.6620	-0.6992	-0.6690	-0.6690	-0.6690	-0.6690	-0.6690	-0.6690	-0.6690
0.975	*****	-0.8080	-0.8515	-0.8252	-0.7262	-0.7262	-0.7262	-0.7262	-0.7262	-0.7262
1.000	-0.7705	-1.3295	-1.4850	-1.7619	-1.7619	-1.7619	-1.7619	-1.7619	-1.7619	-1.7619
-0.200	$C_{p,l}$	$C_{p,l}$	$C_{p,l}$	$C_{p,l}$	$C_{p,l}$	$C_{p,l}$	$C_{p,l}$	$C_{p,l}$	$C_{p,l}$	$C_{p,l}$
-0.400	0.1319	0.1245	0.1415	0.1415	0.1415	0.1415	0.1415	0.1415	0.1415	0.1415
-0.600	0.1274	0.1327	0.1160	0.0030	-0.3527	-0.3527	-0.3527	-0.3527	-0.3527	-0.3527
-0.700	0.1423	0.1352	0.1148	0.0160	-0.3662	-0.3662	-0.3662	-0.3662	-0.3662	-0.3662
-0.800	0.1630	0.1342	0.1172	0.0337	-0.3826	-0.3826	-0.3826	-0.3826	-0.3826	-0.3826
-0.850	0.1917	*****	0.1222	0.0546	-0.3801	-0.3801	-0.3801	-0.3801	-0.3801	-0.3801
-0.900	*****	0.1744	0.1356	0.0651	-0.4078	-0.4078	-0.4078	-0.4078	-0.4078	-0.4078
-0.950	0.2132	0.1986	0.1610	0.0927	-0.4356	-0.4356	-0.4356	-0.4356	-0.4356	-0.4356
-0.975	0.2132	0.2057	0.1904	0.1447	-0.2200	-0.2200	-0.2200	-0.2200	-0.2200	-0.2200
-1.000	0.1588	0.1588	0.1571	0.1548	-0.0267	-0.0267	-0.0267	-0.0267	-0.0267	-0.0267
-1.000	-0.7850	-1.2303	-1.7107	-1.6349	-0.9027	-0.9027	-0.9027	-0.9027	-0.9027	-0.9027

Medium Radius L.E.
 Run No. = 21, Point No. = 416
 $C_N = 0.259$, $C_m = -0.0349$
 $\alpha = 8.0^\circ$, $M_\infty = 0.398$
 $R_{mac} = 59.9 \times 10^6$



x/c_R	starb'd C_p	port C_p
0.10	-0.3765	*****
0.20	-0.7705	-0.7850
0.30	-1.1008	*****
0.40	-1.3295	-1.2303
0.50	-1.6164	*****
0.60	-1.4850	-1.7107
0.70	-1.5179	*****
0.80	-1.7619	-1.6349
0.90	*****	*****
0.95	-1.0462	-0.9027

Table C2. Continued.

η	$x/c_R = .2$		$x/c_R = .4$		$x/c_R = .6$		$x/c_R = .8$		$x/c_R = .95$	
	$C_{p,u}$	$C_{p,u}$	$C_{p,u}$	$C_{p,u}$	$C_{p,u}$	$C_{p,u}$	$C_{p,u}$	$C_{p,u}$	$C_{p,u}$	$C_{p,u}$
0.050	-0.1547	-0.1110	0.0232	*****	*****	*****	*****	*****	*****	
0.100	-0.1619	-0.1161	0.0094	*****	*****	*****	*****	*****	*****	
0.150	-0.1723	-0.1149	-0.0067	*****	*****	*****	*****	*****	*****	
0.200	-0.1776	-0.1179	-0.0219	*****	*****	*****	*****	*****	-0.2611	
0.250	*****	-0.1256	-0.0391	-0.1335	-0.2548	*****	*****	*****	-0.2548	
0.300	-0.1896	-0.1301	-0.0510	-0.1250	-0.2558	*****	*****	*****	-0.2558	
0.350	*****	-0.1365	-0.0677	-0.1207	-0.2517	*****	*****	*****	-0.2517	
0.400	-0.2238	-0.1459	-0.0769	-0.1194	-0.2589	*****	*****	*****	-0.2589	
0.450	-0.2456	-0.1597	-0.0771	-0.1216	-0.2595	*****	*****	*****	-0.2595	
0.500	-0.2677	-0.1668	-0.1091	-0.1269	-0.2665	*****	*****	*****	-0.2665	
0.525	*****	-0.1797	-0.1157	-0.1303	-0.2691	*****	*****	*****	-0.2691	
0.550	-0.2903	-0.1928	-0.1224	-0.1330	-0.2684	*****	*****	*****	-0.2684	
0.575	*****	-0.2023	-0.1249	-0.1388	-0.2740	*****	*****	*****	-0.2740	
0.600	-0.3207	-0.2140	-0.1481	-0.1470	-0.2733	*****	*****	*****	-0.2733	
0.625	*****	*****	-0.1558	-0.1510	-0.2742	*****	*****	*****	-0.2742	
0.650	-0.3530	-0.2354	-0.1696	-0.1626	-0.2747	*****	*****	*****	-0.2747	
0.675	*****	-0.2624	-0.1857	-0.1755	-0.2685	*****	*****	*****	-0.2685	
0.700	-0.3875	-0.2888	-0.2016	-0.1891	-0.2699	*****	*****	*****	-0.2699	
0.725	*****	-0.3187	*****	-0.2038	-0.2731	*****	*****	*****	-0.2731	
0.750	-0.4199	-0.3505	*****	-0.2244	-0.2691	*****	*****	*****	-0.2691	
0.775	*****	-0.3911	-0.2780	-0.2475	-0.2622	*****	*****	*****	-0.2622	
0.800	-0.4522	-0.4313	-0.3207	-0.2723	*****	*****	*****	*****	*****	
0.825	*****	-0.4732	-0.3715	-0.2926	-0.2621	*****	*****	*****	-0.2621	
0.850	-0.4910	-0.5199	-0.4363	-0.3535	-0.2673	*****	*****	*****	-0.2673	
0.875	*****	-0.5731	-0.5100	-0.4238	-0.3554	*****	*****	*****	-0.3554	
0.900	-0.5469	-0.6304	-0.5961	-0.5240	-0.5002	*****	*****	*****	-0.5002	
0.925	*****	-0.7002	-0.6898	-0.6337	-1.0003	*****	*****	*****	-1.0003	
0.950	-0.6464	-0.7868	-0.8152	-0.7648	-0.8073	*****	*****	*****	-0.8073	
0.975	*****	-0.9802	-1.0171	-0.9714	-0.8050	*****	*****	*****	-0.8050	
1.000	-1.0469	-1.7651	-1.9538	-2.3351	-1.3949	*****	*****	*****	-1.3949	
-0.200	$C_{p,l}$	0.1541	0.1437	0.1549	*****	*****	*****	*****	-0.3056	
-0.400	$C_{p,l}$	0.1501	0.1516	0.1312	0.0073	-0.3527	*****	*****	-0.3527	
-0.600	$C_{p,l}$	0.1685	0.1539	0.1321	0.0292	-0.3722	*****	*****	-0.3722	
-0.700	$C_{p,l}$	0.1879	0.1567	0.1344	0.0467	-0.3881	*****	*****	-0.3881	
-0.800	$C_{p,l}$	0.2151	*****	0.1428	0.0702	-0.3834	*****	*****	-0.3834	
-0.850	$C_{p,l}$	*****	0.1961	0.1566	0.0817	-0.4080	*****	*****	-0.4080	
-0.900	$C_{p,l}$	*****	0.2145	0.1798	0.1117	-0.4241	*****	*****	-0.4241	
-0.950	$C_{p,l}$	0.2015	0.2011	0.1921	0.1540	-0.1933	*****	*****	-0.1933	
-0.975	$C_{p,l}$	*****	0.1199	0.1293	0.1396	-0.0108	*****	*****	-0.0108	
-1.000	$C_{p,l}$	-1.0960	-1.6546	-2.2943	-2.1839	-1.2269	*****	*****	-1.2269	

Medium Radius L.E.
 Run No. = 21, Point No. = 417
 $C_N = 0.300$, $C_m = -0.0417$
 $\alpha = 9.1^\circ$, $M_\infty = 0.398$
 $R_{mac} = 60.2 \times 10^6$

Leading Edge Pressures

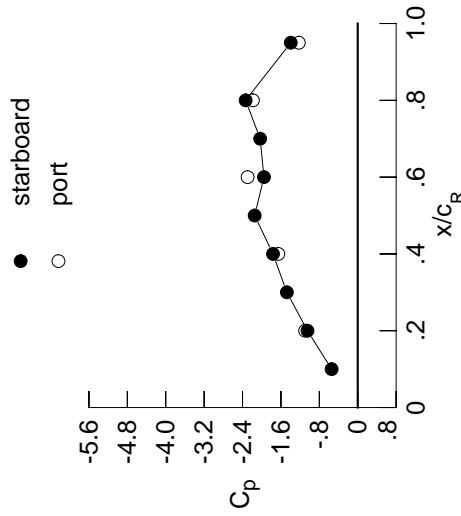

x/c_R	starb'd C_p	port C_p
0.10	-0.5444	*****
0.20	-1.0469	-1.0960
0.30	-1.4763	*****
0.40	-1.7651	-1.6546
0.50	-2.1471	*****
0.60	-1.9538	-2.2943
0.70	-2.0330	*****
0.80	-2.3351	-2.1839
0.90	*****	*****
0.95	-1.3949	-1.2269

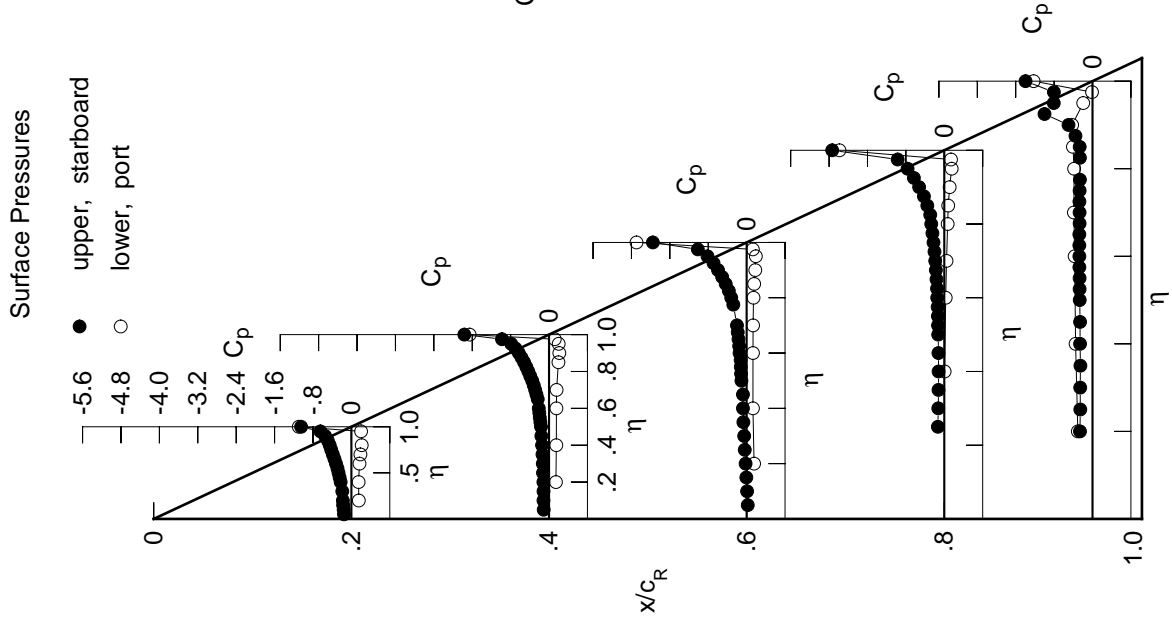
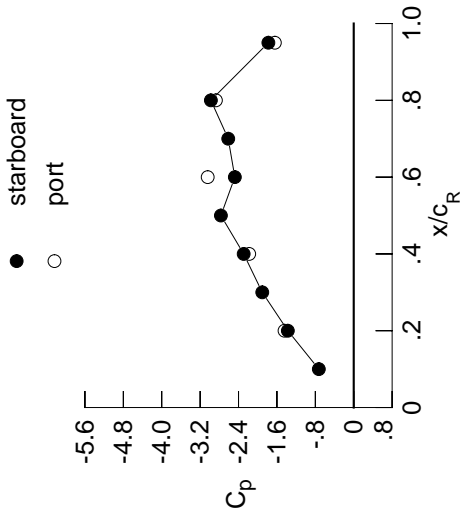

Table C2. Continued.

η	$x/c_R = .2$		$x/c_R = .4$		$x/c_R = .6$		$x/c_R = .8$		$x/c_R = .95$	
	$C_{p,u}$	$C_{p,u}$	$C_{p,u}$	$C_{p,u}$	$C_{p,u}$	$C_{p,u}$	$C_{p,u}$	$C_{p,u}$	$C_{p,u}$	$C_{p,u}$
0.050	-0.1666	-0.1204	0.0182	*****	*****	*****	*****	*****	*****	*****
0.100	-0.1750	-0.1249	0.0045	*****	*****	*****	*****	*****	*****	*****
0.150	-0.1889	-0.1264	-0.0123	*****	*****	*****	*****	*****	*****	*****
0.200	-0.1947	-0.1285	-0.0279	*****	*****	*****	*****	*****	*****	-0.2661
0.250	*****	-0.1359	-0.0470	-0.1363	-0.1363	-0.1363	-0.1363	-0.1363	-0.1363	-0.2585
0.300	-0.2085	-0.1429	-0.0590	-0.1291	-0.1291	-0.1291	-0.1291	-0.1291	-0.1291	-0.2564
0.350	*****	-0.1509	-0.0743	-0.1247	-0.1247	-0.1247	-0.1247	-0.1247	-0.1247	-0.2498
0.400	-0.2443	-0.1614	-0.0865	-0.1242	-0.1242	-0.1242	-0.1242	-0.1242	-0.1242	-0.2554
0.450	-0.2672	-0.1774	-0.0888	-0.1279	-0.1279	-0.1279	-0.1279	-0.1279	-0.1279	-0.2584
0.500	-0.2922	-0.1878	-0.1215	-0.1336	-0.1336	-0.1336	-0.1336	-0.1336	-0.1336	-0.2649
0.525	*****	-0.2009	-0.1287	-0.1375	-0.1375	-0.1375	-0.1375	-0.1375	-0.1375	-0.2694
0.550	-0.3176	-0.2149	-0.1389	-0.1400	-0.1400	-0.1400	-0.1400	-0.1400	-0.1400	-0.2696
0.575	*****	-0.2249	-0.1405	-0.1486	-0.1486	-0.1486	-0.1486	-0.1486	-0.1486	-0.2784
0.600	-0.3518	-0.2385	-0.1669	-0.1580	-0.1580	-0.1580	-0.1580	-0.1580	-0.1580	-0.2789
0.625	*****	*****	-0.1753	-0.1655	-0.1655	-0.1655	-0.1655	-0.1655	-0.1655	-0.2811
0.650	-0.3894	-0.2624	-0.1942	-0.1800	-0.1800	-0.1800	-0.1800	-0.1800	-0.1800	-0.2876
0.675	*****	-0.2914	-0.2117	-0.1968	-0.1968	-0.1968	-0.1968	-0.1968	-0.1968	-0.2874
0.700	-0.4288	-0.3198	-0.2303	-0.2146	-0.2146	-0.2146	-0.2146	-0.2146	-0.2146	-0.2923
0.725	*****	-0.3512	*****	-0.2348	-0.2348	-0.2348	-0.2348	-0.2348	-0.2348	-0.2971
0.750	-0.4684	-0.3859	*****	-0.2581	-0.2581	-0.2581	-0.2581	-0.2581	-0.2581	-0.2953
0.775	*****	-0.4288	-0.3112	-0.2841	-0.2841	-0.2841	-0.2841	-0.2841	-0.2841	-0.2876
0.800	-0.5103	-0.4775	-0.3549	-0.3042	-0.3042	-0.3042	-0.3042	-0.3042	-0.3042	*****
0.825	*****	-0.5275	-0.4076	-0.3259	-0.3259	-0.3259	-0.3259	-0.3259	-0.3259	-0.2677
0.850	-0.5612	-0.5805	-0.4781	-0.3801	-0.3801	-0.3801	-0.3801	-0.3801	-0.3801	-0.2745
0.875	*****	-0.6450	-0.5621	-0.4521	-0.4521	-0.4521	-0.4521	-0.4521	-0.4521	-0.3392
0.900	-0.6349	-0.7135	-0.6650	-0.5646	-0.5646	-0.5646	-0.5646	-0.5646	-0.5646	-0.4732
0.925	*****	-0.8044	-0.7765	-0.6949	-0.6949	-0.6949	-0.6949	-0.6949	-0.6949	-0.9454
0.950	-0.7698	-0.9172	-0.9320	-0.8561	-0.8561	-0.8561	-0.8561	-0.8561	-0.8561	-0.8153
0.975	*****	-1.1649	-1.1893	-1.1182	-0.8650	-0.8650	-0.8650	-0.8650	-0.8650	-0.8650
1.000	-1.3724	-2.2925	-2.4771	-2.9760	-1.7783	-1.7783	-1.7783	-1.7783	-1.7783	-1.7783
-0.200	$C_{p,l}$	0.1639	0.1724	*****	*****	*****	*****	*****	*****	-0.2962
-0.400	0.1757	0.1736	0.1487	0.0221	-0.3478	-0.3478	-0.3478	-0.3478	-0.3478	-0.3478
-0.600	0.1945	0.1776	0.1521	0.0463	-0.3691	-0.3691	-0.3691	-0.3691	-0.3691	-0.3691
-0.700	0.2133	0.1820	0.1575	0.0641	-0.3862	-0.3862	-0.3862	-0.3862	-0.3862	-0.3862
-0.800	0.2367	*****	0.1655	0.0898	-0.3834	-0.3834	-0.3834	-0.3834	-0.3834	-0.3834
-0.850	*****	0.2185	0.1802	0.1024	-0.4014	-0.4014	-0.4014	-0.4014	-0.4014	-0.4014
-0.900	*****	0.2288	0.1976	0.1322	-0.4074	-0.4074	-0.4074	-0.4074	-0.4074	-0.4074
-0.950	0.1831	0.1901	0.1879	0.1603	-0.1652	-0.1652	-0.1652	-0.1652	-0.1652	-0.1652
-0.975	*****	0.0642	0.0865	0.1153	0.0006	0.0006	0.0006	0.0006	0.0006	0.0006
-1.000	-1.4415	-2.1776	-3.0426	-2.8715	-1.6436	-1.6436	-1.6436	-1.6436	-1.6436	-1.6436

Medium Radius L.E.
 Run No. = 21, Point No. = 418
 $C_N = 0.340$, $C_m = -0.0494$
 $\alpha = 10.1^\circ$, $M_\infty = 0.398$
 $R_{mac} = 60.5 \times 10^6$

Leading Edge Pressures



x/c_R	starb'd C_p	port C_p
0.10	-0.7276	*****
0.20	-1.3724	-1.4415
0.30	-1.9055	*****
0.40	-2.2925	-2.1776
0.50	-2.7673	*****
0.60	-2.4771	-3.0426
0.70	-2.6147	*****
0.80	-2.9760	-2.8715
0.90	*****	*****
0.95	-1.7783	-1.6436

Surface Pressures

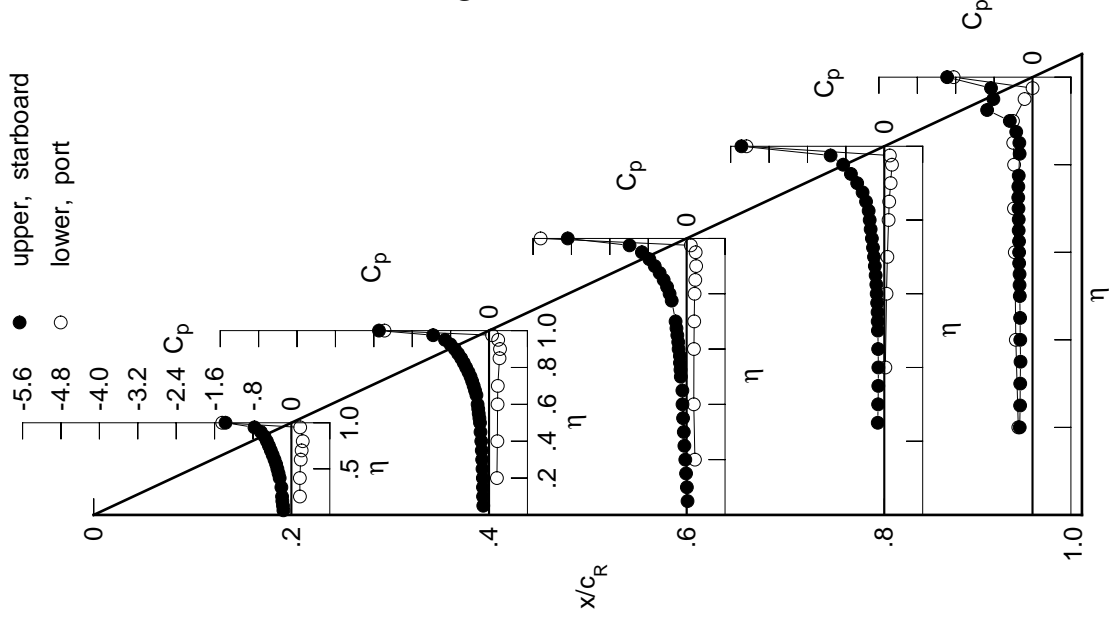

Table C2. Continued.

η	$x/c_R = .2$		$x/c_R = .4$		$x/c_R = .6$		$x/c_R = .8$		$x/c_R = .95$	
	$C_{p,u}$	$C_{p,u}$	$C_{p,u}$	$C_{p,u}$	$C_{p,u}$	$C_{p,u}$	$C_{p,u}$	$C_{p,u}$	$C_{p,u}$	$C_{p,u}$
0.050	-0.1793	-0.1323	0.0110	*****	*****	*****	*****	*****	*****	*****
0.100	-0.1873	-0.1346	-0.0034	*****	*****	*****	*****	*****	*****	*****
0.150	-0.2045	-0.1364	-0.0192	*****	*****	*****	*****	*****	*****	*****
0.200	-0.2128	-0.1408	-0.0364	*****	*****	*****	*****	*****	*****	-0.2738
0.250	*****	-0.1516	-0.0558	-0.1427	-0.2639	*****	*****	*****	*****	*****
0.300	-0.2301	-0.1566	-0.0688	-0.1358	-0.2615	*****	*****	*****	*****	*****
0.350	*****	-0.1667	-0.0858	-0.1317	-0.2544	*****	*****	*****	*****	*****
0.400	-0.2673	-0.1770	-0.0988	-0.1317	-0.2599	*****	*****	*****	*****	*****
0.450	-0.2893	-0.1982	-0.1021	-0.1347	-0.2596	*****	*****	*****	*****	*****
0.500	-0.3168	-0.2099	-0.1364	-0.1423	-0.2680	*****	*****	*****	*****	*****
0.525	*****	-0.2269	-0.1461	-0.1446	-0.2712	*****	*****	*****	*****	*****
0.550	-0.3452	-0.2407	-0.1561	-0.1500	-0.2761	*****	*****	*****	*****	*****
0.575	*****	-0.2528	-0.1622	-0.1549	-0.2858	*****	*****	*****	*****	*****
0.600	-0.3820	-0.2658	-0.1910	-0.1654	-0.2928	*****	*****	*****	*****	*****
0.625	*****	*****	-0.2043	-0.1755	-0.2952	*****	*****	*****	*****	*****
0.650	-0.4248	-0.2947	-0.2259	-0.1952	-0.3069	*****	*****	*****	*****	*****
0.675	*****	-0.3211	-0.2492	-0.2283	-0.3184	*****	*****	*****	*****	*****
0.700	-0.4695	-0.3519	-0.2714	-0.2612	-0.3462	*****	*****	*****	*****	*****
0.725	*****	-0.3833	*****	-0.2969	-0.3822	*****	*****	*****	*****	*****
0.750	-0.5171	-0.4224	*****	-0.3318	-0.4011	*****	*****	*****	*****	*****
0.775	*****	-0.4688	-0.3552	-0.3607	-0.3999	*****	*****	*****	*****	*****
0.800	-0.5673	-0.5225	-0.3936	-0.3711	*****	*****	*****	*****	*****	*****
0.825	*****	-0.5780	-0.4420	-0.3942	-0.3615	*****	*****	*****	*****	*****
0.850	-0.6325	-0.6419	-0.5146	-0.4229	-0.3631	*****	*****	*****	*****	*****
0.875	*****	-0.7167	-0.6079	-0.4701	-0.3776	*****	*****	*****	*****	*****
0.900	-0.7232	-0.8009	-0.7286	-0.5779	-0.4601	*****	*****	*****	*****	*****
0.925	*****	-0.9075	-0.8604	-0.7350	-0.8806	*****	*****	*****	*****	*****
0.950	-0.8947	-1.0508	-1.0511	-0.9340	-0.8381	*****	*****	*****	*****	*****
0.975	*****	-1.3558	-1.3674	-1.2637	-0.9404	*****	*****	*****	*****	*****
1.000	-1.7182	-2.8918	-3.0295	-3.7348	-2.2504	*****	*****	*****	*****	*****
-0.200	$C_{p,l}$	0.1994	0.1854	0.1867	*****	0.2896	*****	*****	*****	*****
-0.400	$C_{p,l}$	0.1975	0.1913	0.1645	0.0340	-0.3416	*****	*****	*****	*****
-0.600	$C_{p,l}$	0.2167	0.1971	0.1672	0.0597	-0.3585	*****	*****	*****	*****
-0.700	$C_{p,l}$	0.2349	0.2020	0.1753	0.0781	-0.3760	*****	*****	*****	*****
-0.800	$C_{p,l}$	0.2524	*****	0.1819	0.1055	-0.3751	*****	*****	*****	*****
-0.850	$C_{p,l}$	*****	0.2339	0.1960	0.1180	-0.3946	*****	*****	*****	*****
-0.900	$C_{p,l}$	*****	0.2343	0.2079	0.1464	-0.3939	*****	*****	*****	*****
-0.950	$C_{p,l}$	0.1568	0.1721	0.1768	0.1593	-0.1425	*****	*****	*****	*****
-0.975	$C_{p,l}$	*****	0.0001	0.0362	0.0831	0.0052	*****	*****	*****	*****
-1.000	$C_{p,l}$	-1.8082	-2.7073	-3.8425	-3.5872	-2.0376	*****	*****	*****	*****

Medium Radius L.E.

Run No. = 21, Point No. = 419

$C_N = 0.382$, $C_m = -0.0575$

$\alpha = 11.1^\circ$, $M_\infty = 0.398$

$R_{mac} = 60.1 \times 10^6$

Leading Edge Pressures

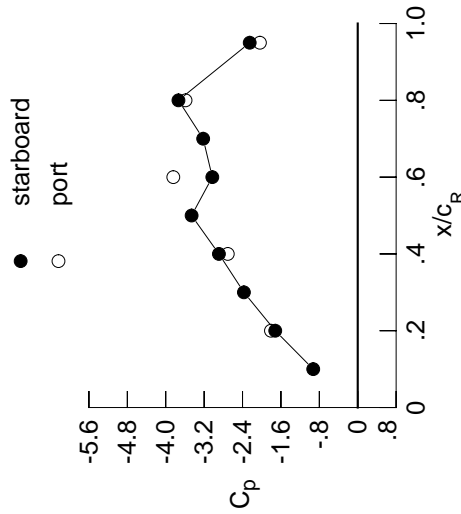

x/c_R	starb'd C_p	port C_p
0.10	-0.9272	*****
0.20	-1.7182	-1.8082
0.30	-2.3710	*****
0.40	-2.8918	-2.7073
0.50	-3.4611	*****
0.60	-3.0295	-3.8425
0.70	-3.2198	*****
0.80	-3.7348	-3.5872
0.90	*****	*****
0.95	-2.2504	-2.0376

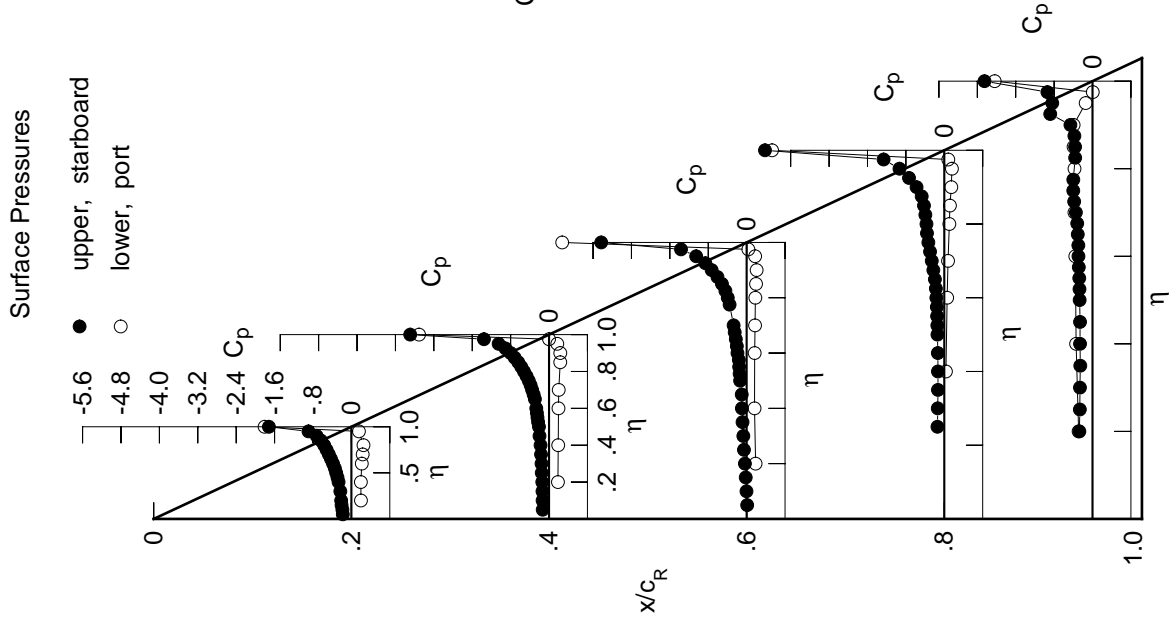

Table C2. Continued.

η	$x/c_R = .2$		$x/c_R = .4$		$x/c_R = .6$		$x/c_R = .8$		$x/c_R = .95$	
	$C_{p,u}$	$C_{p,u}$	$C_{p,u}$	$C_{p,u}$	$C_{p,u}$	$C_{p,u}$	$C_{p,u}$	$C_{p,u}$	$C_{p,u}$	$C_{p,u}$
0.050	-0.1915	-0.1429	0.0037	*****	*****	*****	*****	*****	*****	
0.100	-0.1966	-0.1440	-0.0098	*****	*****	*****	*****	*****	*****	
0.150	-0.2193	-0.1463	-0.0271	*****	*****	*****	*****	*****	*****	
0.200	-0.2295	-0.1514	-0.0449	*****	*****	*****	*****	*****	-0.2854	
0.250	*****	-0.1632	-0.0658	-0.1489	-0.1489	-0.1489	-0.1489	-0.1489	-0.2755	
0.300	-0.2495	-0.1698	-0.0786	-0.1438	-0.1438	-0.1438	-0.1438	-0.1438	-0.2682	
0.350	*****	-0.1820	-0.0949	-0.1406	-0.1406	-0.1406	-0.1406	-0.1406	-0.2577	
0.400	-0.2889	-0.1972	-0.1093	-0.1408	-0.1408	-0.1408	-0.1408	-0.1408	-0.2648	
0.450	-0.3131	-0.2181	-0.1111	-0.1438	-0.1438	-0.1438	-0.1438	-0.1438	-0.2668	
0.500	-0.3415	-0.2368	-0.1503	-0.1485	-0.1485	-0.1485	-0.1485	-0.1485	-0.2723	
0.525	*****	-0.2543	-0.1603	-0.1526	-0.1526	-0.1526	-0.1526	-0.1526	-0.2774	
0.550	-0.3728	-0.2715	-0.1761	-0.1539	-0.1539	-0.1539	-0.1539	-0.1539	-0.2860	
0.575	*****	-0.2847	-0.1852	-0.1588	-0.1588	-0.1588	-0.1588	-0.1588	-0.3035	
0.600	-0.4141	-0.3000	-0.2222	-0.1609	-0.1609	-0.1609	-0.1609	-0.1609	-0.3134	
0.625	*****	*****	-0.2411	-0.1653	-0.1653	-0.1653	-0.1653	-0.1653	-0.3078	
0.650	-0.4603	-0.3305	-0.2750	-0.1934	-0.1934	-0.1934	-0.1934	-0.1934	-0.3023	
0.675	*****	-0.3577	-0.3086	-0.2633	-0.2633	-0.2633	-0.2633	-0.2633	-0.3004	
0.700	-0.5123	-0.3853	-0.3365	-0.3239	-0.3239	-0.3239	-0.3239	-0.3239	-0.3420	
0.725	*****	-0.4169	*****	-0.3533	-0.3533	-0.3533	-0.3533	-0.3533	-0.4005	
0.750	-0.5672	-0.4555	*****	-0.4198	-0.4198	-0.4198	-0.4198	-0.4198	-0.5441	
0.775	*****	-0.5051	-0.4187	-0.5386	-0.5386	-0.5386	-0.5386	-0.5386	-0.7152	
0.800	-0.6270	-0.5623	-0.4503	-0.5753	-0.5753	-0.5753	-0.5753	-0.5753	*****	
0.825	*****	-0.6275	-0.4842	-0.5255	-0.5255	-0.5255	-0.5255	-0.5255	-0.6032	
0.850	-0.7044	-0.6989	-0.5415	-0.5573	-0.5573	-0.5573	-0.5573	-0.5573	-0.5456	
0.875	*****	-0.7874	-0.6349	-0.5884	-0.5884	-0.5884	-0.5884	-0.5884	-0.5290	
0.900	-0.8148	-0.8829	-0.7708	-0.6162	-0.6162	-0.6162	-0.6162	-0.6162	-0.5303	
0.925	*****	-1.0140	-0.9330	-0.6738	-0.6738	-0.6738	-0.6738	-0.6738	-0.6003	
0.950	-1.0247	-1.1855	-1.1590	-0.9070	-0.9070	-0.9070	-0.9070	-0.9070	-0.7793	
0.975	*****	-1.5559	-1.5439	-1.3366	-0.9999	-0.9999	-0.9999	-0.9999	-0.9999	
1.000	-2.1080	-3.5331	-3.5415	-4.5500	-4.5500	-4.5500	-4.5500	-4.5500	-2.7783	
-0.200	0.2223	0.2034	0.2033	*****	*****	*****	*****	*****	-0.2808	
-0.400	0.2192	0.2121	0.1823	0.0493	0.0493	0.0493	0.0493	0.0493	-0.3324	
-0.600	0.2398	0.2167	0.1841	0.0763	0.0763	0.0763	0.0763	0.0763	-0.3323	
-0.700	0.2552	0.2215	0.1944	0.0962	0.0962	0.0962	0.0962	0.0962	-0.3424	
-0.800	0.2668	*****	0.2002	0.1233	0.1233	0.1233	0.1233	0.1233	-0.3453	
-0.850	*****	0.2472	0.2118	0.1367	0.1367	0.1367	0.1367	0.1367	-0.3684	
-0.900	*****	0.2382	0.2177	0.1611	0.1611	0.1611	0.1611	0.1611	-0.3597	
-0.950	0.1243	0.1459	0.1583	0.1552	0.1552	0.1552	0.1552	0.1552	-0.1124	
-0.975	*****	-0.0727	-0.0236	0.0436	0.0436	0.0436	0.0436	0.0436	0.0089	
-1.000	-2.2126	-3.3065	-4.7255	-4.3726	-4.3726	-4.3726	-4.3726	-4.3726	-2.5106	

Medium Radius L.E.
 Run No. = 21, Point No. = 420
 $C_N = 0.431$, $C_m = -0.0702$
 $\alpha = 12.1^\circ$, $M_\infty = 0.398$
 $R_{mac} = 59.5 \times 10^6$

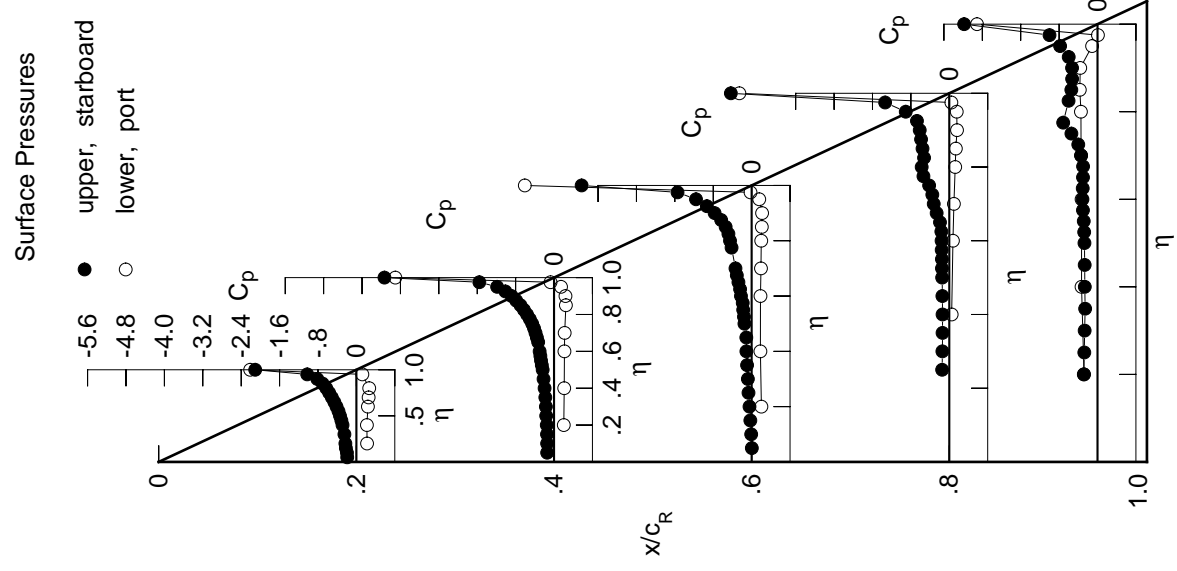
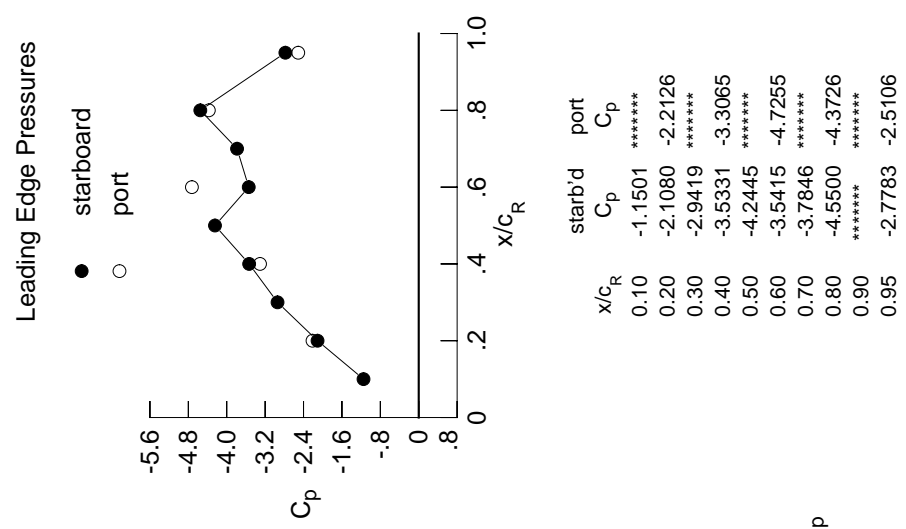

Table C2. Continued.

η	$x/c_R = .2$		$x/c_R = .4$		$x/c_R = .6$		$x/c_R = .8$		$x/c_R = .95$	
	$C_{p,u}$	$C_{p,u}$	$C_{p,u}$	$C_{p,u}$	$C_{p,u}$	$C_{p,u}$	$C_{p,u}$	$C_{p,u}$	$C_{p,u}$	$C_{p,u}$
0.050	-0.2059	-0.1565	-0.0124	*****	*****	*****	*****	*****	*****	*****
0.100	-0.2096	-0.1593	-0.0238	*****	*****	*****	*****	*****	*****	*****
0.150	-0.2295	-0.1577	-0.0411	*****	*****	*****	*****	*****	*****	*****
0.200	-0.2511	-0.1631	-0.0606	*****	*****	*****	*****	*****	*****	-0.3013
0.250	*****	-0.1772	-0.0806	-0.1683	-0.1683	-0.1683	-0.1683	-0.1683	-0.1683	-0.2973
0.300	-0.2765	-0.1872	-0.0969	-0.1629	-0.1629	-0.1629	-0.1629	-0.1629	-0.1629	-0.2869
0.350	*****	-0.2007	-0.1126	-0.1604	-0.1604	-0.1604	-0.1604	-0.1604	-0.1604	-0.2717
0.400	-0.3145	-0.2196	-0.1259	-0.1582	-0.1582	-0.1582	-0.1582	-0.1582	-0.1582	-0.2795
0.450	-0.3386	-0.2469	-0.1262	-0.1600	-0.1600	-0.1600	-0.1600	-0.1600	-0.1600	-0.2943
0.500	-0.3690	-0.2727	-0.1629	-0.1711	-0.1711	-0.1711	-0.1711	-0.1711	-0.1711	-0.2994
0.525	*****	-0.2951	-0.1751	-0.1819	-0.1819	-0.1819	-0.1819	-0.1819	-0.1819	-0.2824
0.550	-0.4021	-0.3162	-0.1940	-0.1955	-0.1955	-0.1955	-0.1955	-0.1955	-0.1955	-0.2791
0.575	*****	-0.3320	-0.2117	-0.2080	-0.2080	-0.2080	-0.2080	-0.2080	-0.2080	-0.3037
0.600	-0.4448	-0.3490	-0.2664	-0.2061	-0.2061	-0.2061	-0.2061	-0.2061	-0.2061	-0.3268
0.625	*****	*****	-0.3020	-0.1900	-0.1900	-0.1900	-0.1900	-0.1900	-0.1900	-0.3469
0.650	-0.4973	-0.3830	-0.3485	-0.1791	-0.1791	-0.1791	-0.1791	-0.1791	-0.1791	-0.3571
0.675	*****	-0.4062	-0.3827	-0.1625	-0.1625	-0.1625	-0.1625	-0.1625	-0.1625	-0.3542
0.700	-0.5552	-0.4327	-0.4086	-0.1343	-0.1343	-0.1343	-0.1343	-0.1343	-0.1343	-0.3478
0.725	*****	-0.4589	*****	-0.1122	-0.1122	-0.1122	-0.1122	-0.1122	-0.1122	-0.3433
0.750	-0.6189	-0.4963	*****	-0.1536	-0.1536	-0.1536	-0.1536	-0.1536	-0.1536	-0.3691
0.775	*****	-0.5428	-0.5626	-0.4249	-0.4249	-0.4249	-0.4249	-0.4249	-0.4249	-0.5171
0.800	-0.6890	-0.6042	-0.6408	-0.8594	-0.8594	-0.8594	-0.8594	-0.8594	-0.8594	*****
0.825	*****	-0.6747	-0.7172	-1.1830	-0.8871	-0.8871	-0.8871	-0.8871	-0.8871	*****
0.850	-0.7823	-0.7546	-0.7468	-1.2883	-0.9137	-0.9137	-0.9137	-0.9137	-0.9137	*****
0.875	*****	-0.8597	-0.7887	-1.2174	-0.8170	-0.8170	-0.8170	-0.8170	-0.8170	*****
0.900	-0.9142	-0.9720	-0.8497	-1.1579	-0.6681	-0.6681	-0.6681	-0.6681	-0.6681	*****
0.925	*****	-1.1250	-0.9488	-1.2731	-0.6082	-0.6082	-0.6082	-0.6082	-0.6082	*****
0.950	-1.1673	-1.3314	-1.1599	-1.3055	-0.5367	-0.5367	-0.5367	-0.5367	-0.5367	*****
0.975	*****	-1.7688	-1.6033	-1.0695	-0.4689	-0.4689	-0.4689	-0.4689	-0.4689	*****
1.000	-2.5589	-4.3477	-3.7583	-1.9202	-0.7757	-0.7757	-0.7757	-0.7757	-0.7757	*****
η	$C_{p,l}$	$C_{p,l}$	$C_{p,l}$	$C_{p,l}$	$C_{p,l}$	$C_{p,l}$	$C_{p,l}$	$C_{p,l}$	$C_{p,l}$	$C_{p,l}$
-0.200	0.2439	0.2234	0.2198	*****	*****	*****	*****	*****	*****	-0.2900
-0.400	0.2426	0.2312	0.2008	0.0634	-0.3402	-0.3402	-0.3402	-0.3402	-0.3402	-0.3402
-0.600	0.2627	0.2374	0.2040	0.0914	-0.3494	-0.3494	-0.3494	-0.3494	-0.3494	-0.3494
-0.700	0.2758	0.2426	0.2142	0.1134	-0.3512	-0.3512	-0.3512	-0.3512	-0.3512	-0.3512
-0.800	0.2812	*****	0.2203	0.1451	-0.3478	-0.3478	-0.3478	-0.3478	-0.3478	-0.3478
-0.850	*****	0.2595	0.2296	0.1599	-0.3739	-0.3739	-0.3739	-0.3739	-0.3739	-0.3739
-0.900	*****	0.2386	0.2273	0.1879	-0.3769	-0.3769	-0.3769	-0.3769	-0.3769	-0.3769
-0.950	0.0847	0.1149	0.1434	0.1887	-0.1405	-0.1405	-0.1405	-0.1405	-0.1405	-0.1405
-0.975	*****	-0.1548	-0.0813	0.1031	-0.0026	-0.0026	-0.0026	-0.0026	-0.0026	-0.0026
-1.000	-2.6785	-3.9342	-4.8649	-1.8472	-0.7697	-0.7697	-0.7697	-0.7697	-0.7697	-0.7697

Medium Radius L.E.

Run No. = 21, Point No. = 421

$C_N = 0.492$, $C_m = -0.0828$

$\alpha = 13.2^\circ$, $M_\infty = 0.397$

$R_{mac} = 59.2 \times 10^6$

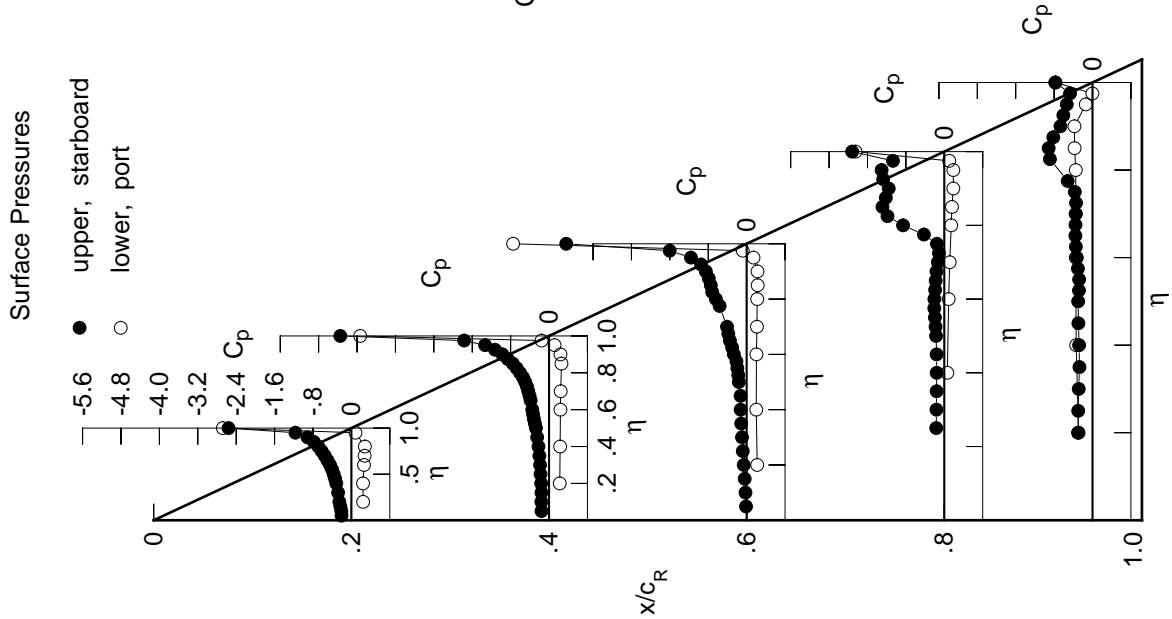
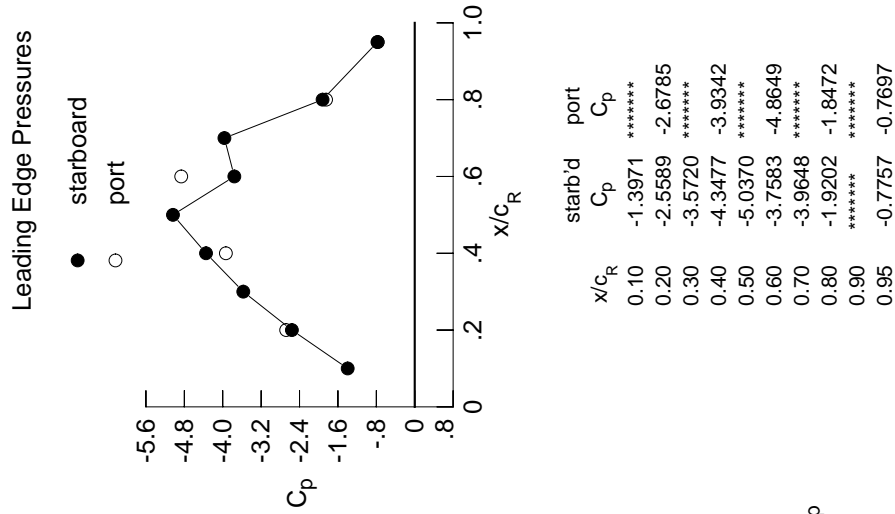
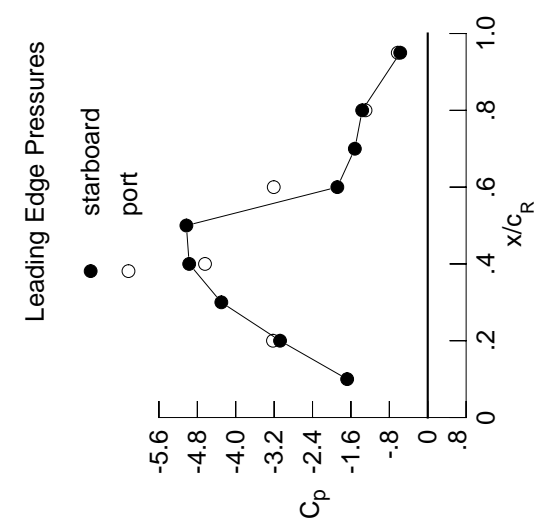

Table C2. Continued.

η	$x/c_R = .2$		$x/c_R = .4$		$x/c_R = .6$		$x/c_R = .8$		$x/c_R = .95$	
	$C_{p,u}$	$C_{p,u}$	$C_{p,u}$	$C_{p,u}$	$C_{p,u}$	$C_{p,u}$	$C_{p,u}$	$C_{p,u}$	$C_{p,u}$	$C_{p,u}$
0.050	-0.2211	-0.1749	-0.0277	*****	*****	*****	*****	*****	*****	*****
0.100	-0.2210	-0.1764	-0.0411	*****	*****	*****	*****	*****	*****	*****
0.150	-0.2410	-0.1738	-0.0572	*****	*****	*****	*****	*****	*****	*****
0.200	-0.2669	-0.1785	-0.0766	*****	*****	*****	*****	*****	*****	-0.3074
0.250	*****	-0.1912	-0.0971	-0.1827	-0.1827	-0.1827	-0.1827	-0.1827	-0.1827	-0.3075
0.300	-0.3060	-0.2020	-0.1145	-0.1761	-0.1761	-0.1761	-0.1761	-0.1761	-0.1761	-0.2991
0.350	*****	-0.2187	-0.1318	-0.1711	-0.1711	-0.1711	-0.1711	-0.1711	-0.1711	-0.2925
0.400	-0.3438	-0.2422	-0.1421	-0.1705	-0.1705	-0.1705	-0.1705	-0.1705	-0.1705	-0.3116
0.450	-0.3679	-0.2780	-0.1363	-0.1818	-0.1818	-0.1818	-0.1818	-0.1818	-0.1818	-0.3085
0.500	-0.3979	-0.3167	-0.1824	-0.1960	-0.1960	-0.1960	-0.1960	-0.1960	-0.1960	-0.3134
0.525	*****	-0.3485	-0.1951	-0.1911	-0.1911	-0.1911	-0.1911	-0.1911	-0.1911	-0.3297
0.550	-0.4322	-0.3765	-0.2179	-0.1867	-0.1867	-0.1867	-0.1867	-0.1867	-0.1867	-0.3418
0.575	*****	-0.3995	-0.2389	-0.1846	-0.1846	-0.1846	-0.1846	-0.1846	-0.1846	-0.3555
0.600	-0.4765	-0.4224	-0.2717	-0.1890	-0.1890	-0.1890	-0.1890	-0.1890	-0.1890	-0.3625
0.625	*****	*****	-0.2557	-0.1972	-0.1972	-0.1972	-0.1972	-0.1972	-0.1972	-0.3758
0.650	-0.5341	-0.4651	-0.2621	-0.2082	-0.2082	-0.2082	-0.2082	-0.2082	-0.2082	-0.3919
0.675	*****	-0.4817	-0.2855	-0.2153	-0.2153	-0.2153	-0.2153	-0.2153	-0.2153	-0.4142
0.700	-0.5984	-0.5008	-0.3332	-0.2207	-0.2207	-0.2207	-0.2207	-0.2207	-0.2207	-0.4755
0.725	*****	-0.5225	*****	-0.2460	-0.2460	-0.2460	-0.2460	-0.2460	-0.2460	-0.5696
0.750	-0.6717	-0.5533	*****	-0.3480	-0.3480	-0.3480	-0.3480	-0.3480	-0.3480	-0.6360
0.775	*****	-0.5948	-0.7864	-0.6329	-0.6329	-0.6329	-0.6329	-0.6329	-0.6329	-0.6743
0.800	-0.7532	-0.6542	-0.8362	-0.9864	*****	*****	*****	*****	*****	*****
0.825	*****	-0.7275	-0.9837	-1.2801	-0.6784	*****	*****	*****	*****	*****
0.850	-0.8635	-0.8051	-1.3563	-1.3461	-0.6574	*****	*****	*****	*****	*****
0.875	*****	-0.9326	-1.7642	-1.1516	-0.5872	*****	*****	*****	*****	*****
0.900	-1.0199	-1.0599	-1.7767	-0.9595	-0.5106	*****	*****	*****	*****	*****
0.925	*****	-1.2334	-1.4738	-0.9242	-0.4788	*****	*****	*****	*****	*****
0.950	-1.3224	-1.4728	-1.5546	-0.9177	-0.4147	*****	*****	*****	*****	*****
0.975	*****	-1.9630	-1.8538	-0.8401	-0.3459	*****	*****	*****	*****	*****
1.000	-3.0767	-4.9696	-1.8835	-1.3655	-0.5728	*****	*****	*****	*****	*****
-0.200	$C_{p,l}$	$C_{p,l}$	$C_{p,l}$	$C_{p,l}$	$C_{p,l}$	$C_{p,l}$	$C_{p,l}$	$C_{p,l}$	$C_{p,l}$	$C_{p,l}$
-0.400	0.2683	0.2457	0.2375	*****	-0.3021	*****	*****	*****	*****	*****
-0.600	0.2683	0.2553	0.2193	0.0720	-0.3502	*****	*****	*****	*****	*****
-0.700	0.2964	0.2661	0.2374	0.0968	-0.3861	*****	*****	*****	*****	*****
-0.800	0.2937	*****	0.2478	0.1501	-0.4140	*****	*****	*****	*****	*****
-0.850	*****	0.2732	0.2578	0.1656	-0.4295	*****	*****	*****	*****	*****
-0.900	*****	0.2381	0.2574	0.1916	-0.4185	*****	*****	*****	*****	*****
-0.950	0.0382	0.0799	0.1685	0.1926	-0.1633	*****	*****	*****	*****	*****
-0.975	*****	-0.2431	-0.0495	0.1151	-0.0178	*****	*****	*****	*****	*****
-1.000	-3.2236	-4.6397	-3.2076	-1.2962	-0.6238	*****	*****	*****	*****	*****

Medium Radius L.E.
 Run No. = 21, Point No. = 422
 $C_N = 0.530$, $C_m = -0.0815$
 $\alpha = 14.2^\circ$, $M_\infty = 0.398$
 $R_{mac} = 59.2 \times 10^6$



x/c_R	starb'd C_p	port C_p
0.10	-1.6782	*****
0.20	-3.0767	-3.2236
0.30	-4.3003	*****
0.40	-4.9696	-4.6397
0.50	-5.0282	*****
0.60	-1.8835	-3.2076
0.70	-1.5182	*****
0.80	-1.3655	-1.2962
0.90	*****	*****
0.95	-0.5728	-0.6238

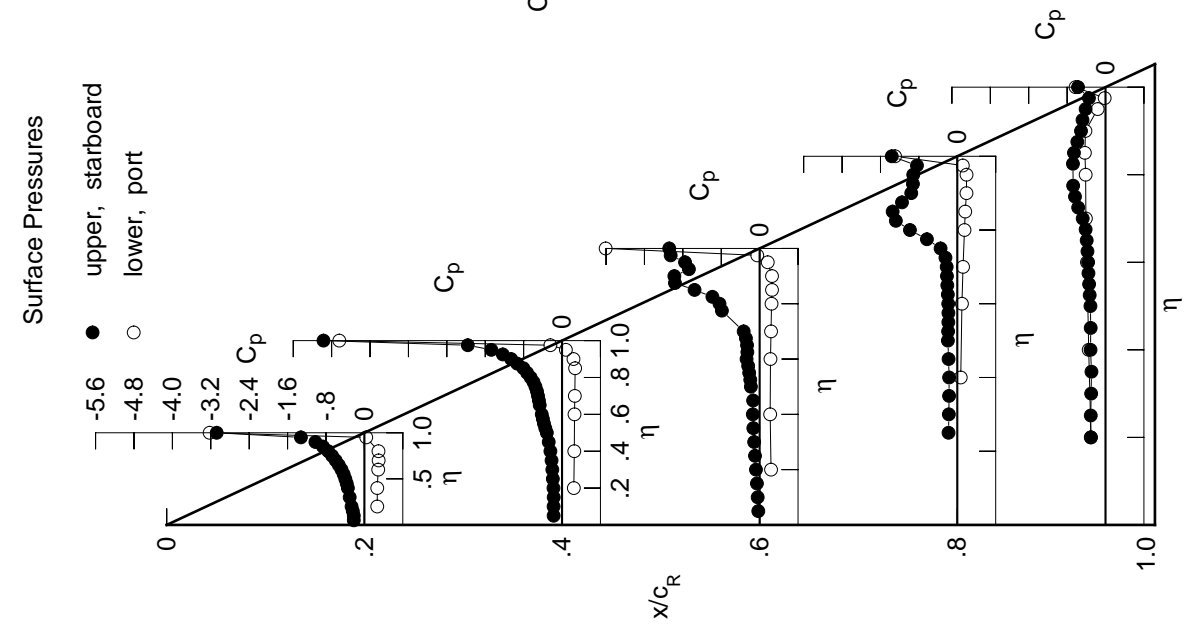
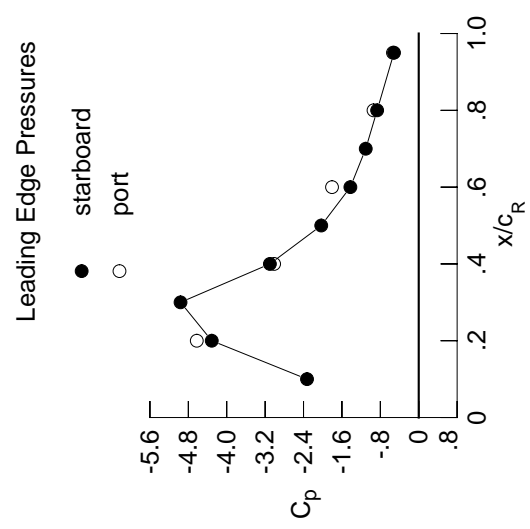

Table C2. Continued.

η	$x/c_R = .2$		$x/c_R = .4$		$x/c_R = .6$		$x/c_R = .8$		$x/c_R = .95$	
	$C_{p,u}$	$C_{p,u}$	$C_{p,u}$	$C_{p,u}$	$C_{p,u}$	$C_{p,u}$	$C_{p,u}$	$C_{p,u}$	$C_{p,u}$	$C_{p,u}$
0.050	-0.2612	-0.2300	-0.0685	*****	*****	*****	*****	*****	*****	*****
0.100	-0.2568	-0.2336	-0.0821	*****	*****	*****	*****	*****	*****	*****
0.150	-0.2726	-0.2309	-0.0977	*****	*****	*****	*****	*****	*****	*****
0.200	-0.2967	-0.2334	-0.1198	*****	*****	*****	*****	*****	*****	-0.3054
0.250	*****	-0.2425	-0.1381	-0.1991	-0.1849	-0.3394	*****	*****	*****	-0.3126
0.300	-0.3782	-0.2493	-0.1489	-0.1849	-0.1849	-0.3394	*****	*****	*****	-0.3394
0.350	*****	-0.2559	-0.1791	-0.1838	-0.3404	*****	*****	*****	*****	-0.3404
0.400	-0.4296	-0.2960	-0.2003	-0.1733	-0.3623	*****	*****	*****	*****	-0.3623
0.450	-0.4537	-0.3786	-0.1942	-0.1713	-0.3798	*****	*****	*****	*****	-0.3798
0.500	-0.4823	-0.3915	-0.2341	-0.1743	-0.4017	*****	*****	*****	*****	-0.4017
0.525	*****	-0.3901	-0.2537	-0.1706	-0.4234	*****	*****	*****	*****	-0.4234
0.550	-0.5141	-0.3968	-0.2774	-0.1710	-0.4431	*****	*****	*****	*****	-0.4431
0.575	*****	-0.4210	-0.2901	-0.1737	-0.4884	*****	*****	*****	*****	-0.4884
0.600	-0.5579	-0.4708	-0.3217	-0.1890	-0.5183	*****	*****	*****	*****	-0.5183
0.625	*****	*****	-0.3143	-0.2122	-0.5619	*****	*****	*****	*****	-0.5619
0.650	-0.6203	-0.5628	-0.3374	-0.2721	-0.6081	*****	*****	*****	*****	-0.6081
0.675	*****	-0.6307	-0.3650	-0.4086	-0.6324	*****	*****	*****	*****	-0.6324
0.700	-0.6949	-0.7437	-0.4180	-0.6122	-0.6552	*****	*****	*****	*****	-0.6552
0.725	*****	-0.9077	*****	-0.8718	-0.6779	*****	*****	*****	*****	-0.6779
0.750	-0.7880	-1.0478	*****	-1.0792	-0.6750	*****	*****	*****	*****	-0.6750
0.775	*****	-1.0349	-1.3060	-1.2200	-0.6711	*****	*****	*****	*****	-0.6711
0.800	-0.8941	-0.9024	-1.7746	-1.1675	*****	*****	*****	*****	*****	-0.6711
0.825	*****	-0.8314	-2.0153	-0.9941	-0.6125	*****	*****	*****	*****	-0.6125
0.850	-1.0445	-1.0220	-1.8551	-0.7544	-0.5618	*****	*****	*****	*****	-0.5618
0.875	*****	-1.8296	-1.5142	-0.6631	-0.5183	*****	*****	*****	*****	-0.5183
0.900	-1.2554	-2.5423	-1.3743	-0.6534	-0.4795	*****	*****	*****	*****	-0.4795
0.925	*****	-2.6205	-1.3370	-0.6225	-0.4627	*****	*****	*****	*****	-0.4627
0.950	-1.6677	-2.2629	-1.2551	-0.5850	-0.3872	*****	*****	*****	*****	-0.3872
0.975	*****	-2.0158	-1.1786	-0.5401	-0.3267	*****	*****	*****	*****	-0.3267
1.000	-4.3119	-3.1011	-1.4244	-0.8664	-0.5156	*****	*****	*****	*****	-0.5156
-0.200	$C_{p,l}$	$C_{p,l}$	$C_{p,l}$	$C_{p,l}$	$C_{p,l}$	$C_{p,l}$	$C_{p,l}$	$C_{p,l}$	$C_{p,l}$	$C_{p,l}$
-0.400	0.3218	0.2929	0.2721	*****	-0.3187	*****	*****	*****	*****	-0.3187
-0.600	0.3207	0.3038	0.2543	0.0928	-0.3630	*****	*****	*****	*****	-0.3630
-0.700	0.3359	0.3108	0.2601	0.1170	-0.4373	*****	*****	*****	*****	-0.4373
-0.800	0.3353	0.3157	0.2705	0.1401	-0.4746	*****	*****	*****	*****	-0.4746
-0.850	0.3122	*****	0.2758	0.1689	-0.4577	*****	*****	*****	*****	-0.4577
-0.900	*****	0.3077	0.2811	0.1832	-0.4550	*****	*****	*****	*****	-0.4550
-0.950	*****	0.2549	0.2685	0.2067	-0.4232	*****	*****	*****	*****	-0.4232
-0.975	-0.0795	0.0612	0.1657	0.1948	-0.1516	*****	*****	*****	*****	-0.1516
-1.000	*****	-0.2944	-0.0444	0.1095	-0.0118	*****	*****	*****	*****	-0.0118
	-4.6238	-3.0132	-1.8067	-0.9420	-0.5371	*****	*****	*****	*****	-0.5371

Medium Radius L.E.
 Run No. = 21, Point No. = 423
 $C_N = 0.632$, $C_m = -0.0892$
 $\alpha = 16.3^\circ$, $M_\infty = 0.397$
 $R_{mac} = 59.3 \times 10^6$



x/c_R	starb'd C_p	port C_p
0.10	-2.3268	*****
0.20	-4.3119	-4.6238
0.30	-4.9620	*****
0.40	-3.1011	-3.0132
0.50	-2.0310	*****
0.60	-1.4244	-1.8067
0.70	-1.1041	*****
0.80	-0.8664	-0.9420
0.90	*****	*****
0.95	-0.5156	-0.5371

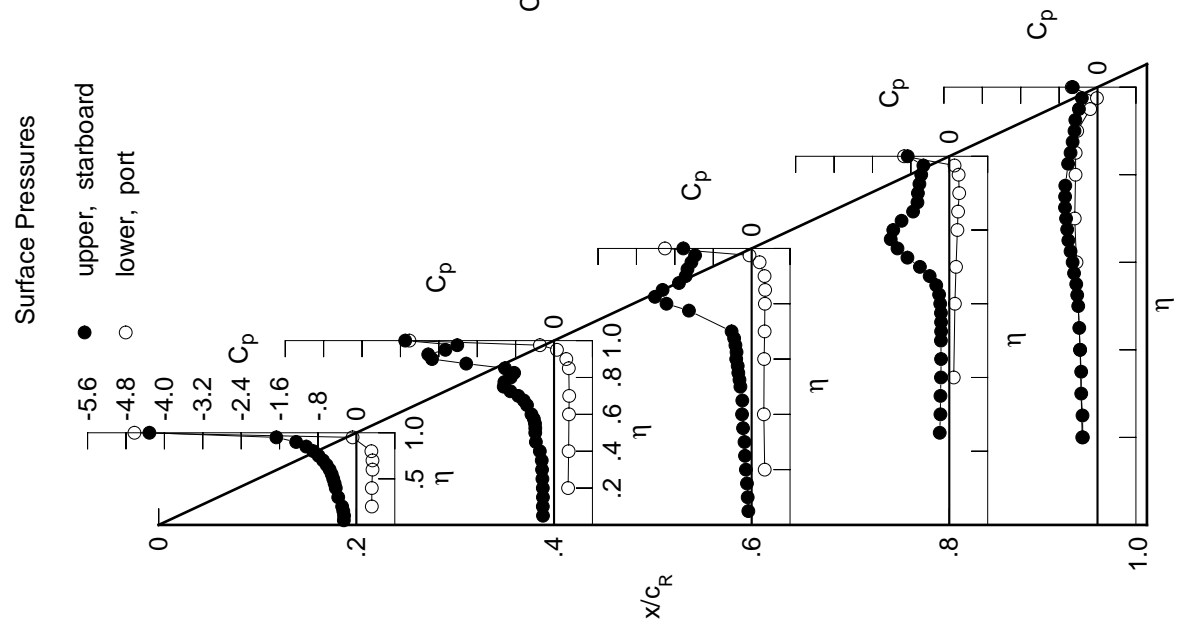
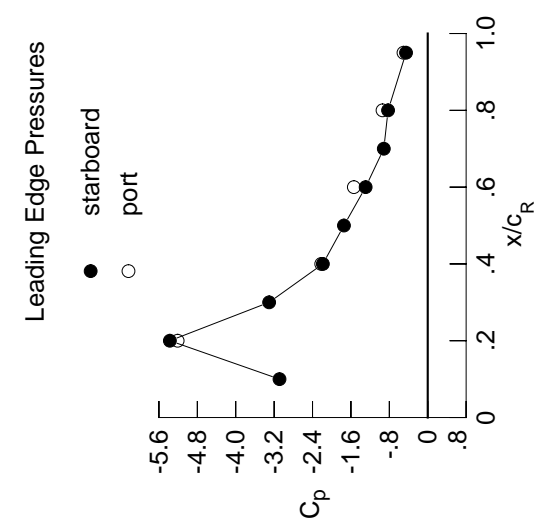

Table C2. Continued.

η	$x/c_R = 0.2$		$x/c_R = 0.4$		$x/c_R = 0.6$		$x/c_R = 0.8$		$x/c_R = 0.95$	
	$C_{p,u}$	$C_{p,u}$	$C_{p,u}$	$C_{p,u}$	$C_{p,u}$	$C_{p,u}$	$C_{p,u}$	$C_{p,u}$	$C_{p,u}$	$C_{p,u}$
0.050	-0.3168	-0.2970	-0.0992	*****	*****	*****	*****	*****	*****	*****
0.100	-0.3109	-0.3017	-0.1155	*****	*****	*****	*****	*****	*****	*****
0.150	-0.3241	-0.3009	-0.1311	*****	*****	*****	*****	*****	*****	*****
0.200	-0.3355	-0.2997	-0.1487	*****	*****	*****	*****	*****	*****	*****
0.250	*****	-0.3059	-0.1636	-0.2226	-0.3109	*****	*****	*****	*****	-0.2862
0.300	-0.4454	-0.3118	-0.1816	-0.2091	-0.3514	*****	*****	*****	*****	*****
0.350	*****	-0.3489	-0.2074	-0.2082	-0.3659	*****	*****	*****	*****	*****
0.400	-0.5635	-0.3705	-0.2529	-0.2116	-0.3918	*****	*****	*****	*****	*****
0.450	-0.5885	-0.4523	-0.2543	-0.2179	-0.4141	*****	*****	*****	*****	*****
0.500	-0.6161	-0.5523	-0.2734	-0.2313	-0.4518	*****	*****	*****	*****	*****
0.525	*****	-0.5214	-0.2752	-0.2395	-0.4880	*****	*****	*****	*****	*****
0.550	-0.6461	-0.4772	-0.2804	-0.2675	-0.5155	*****	*****	*****	*****	*****
0.575	*****	-0.4529	-0.2941	-0.3116	-0.5736	*****	*****	*****	*****	*****
0.600	-0.6795	-0.4495	-0.3655	-0.3897	-0.6086	*****	*****	*****	*****	*****
0.625	*****	*****	-0.4213	-0.4949	-0.6494	*****	*****	*****	*****	*****
0.650	-0.7543	-0.4365	-0.5919	-0.6322	-0.6834	*****	*****	*****	*****	*****
0.675	*****	-0.4487	-0.8240	-0.8063	-0.6943	*****	*****	*****	*****	*****
0.700	-0.8508	-0.4836	-1.1096	-0.9635	-0.7063	*****	*****	*****	*****	*****
0.725	*****	-0.6112	*****	-1.0830	-0.7142	*****	*****	*****	*****	*****
0.750	-0.9715	-1.0306	*****	-1.1042	-0.6975	*****	*****	*****	*****	*****
0.775	-1.17379	-1.9872	-1.0822	-0.6664	*****	*****	*****	*****	*****	*****
0.800	-1.0904	-2.4025	-1.8989	-0.9394	*****	*****	*****	*****	*****	*****
0.825	*****	-2.7139	-1.5806	-0.7771	-0.5680	*****	*****	*****	*****	*****
0.850	-1.2561	-2.7193	-1.3070	-0.6755	-0.5202	*****	*****	*****	*****	*****
0.875	*****	-2.4355	-1.2849	-0.6468	-0.4818	*****	*****	*****	*****	*****
0.900	-1.5250	-2.0811	-1.2811	-0.6425	-0.4521	*****	*****	*****	*****	*****
0.925	*****	-1.9347	-1.2404	-0.6212	-0.4369	*****	*****	*****	*****	*****
0.950	-2.0286	-1.8008	-1.1851	-0.5875	-0.3592	*****	*****	*****	*****	*****
0.975	*****	-1.6701	-1.1231	-0.5662	-0.2939	*****	*****	*****	*****	*****
1.000	-5.3724	-2.1847	-1.2939	-0.8261	-0.4519	*****	*****	*****	*****	*****
-0.200	$C_{p,l}$	$C_{p,l}$	$C_{p,l}$	$C_{p,l}$	$C_{p,l}$	$C_{p,l}$	$C_{p,l}$	$C_{p,l}$	$C_{p,l}$	$C_{p,l}$
-0.400	0.3746	0.3375	0.3045	*****	-0.3282	*****	*****	*****	*****	*****
-0.600	0.3746	0.3475	0.2879	0.1161	-0.3822	*****	*****	*****	*****	*****
-0.700	0.3842	0.3521	0.2943	0.1408	-0.4702	*****	*****	*****	*****	*****
-0.800	0.3739	0.3548	0.3032	0.1624	-0.4987	*****	*****	*****	*****	*****
-0.850	0.3272	*****	0.3052	0.1893	-0.4587	*****	*****	*****	*****	*****
-0.900	*****	0.3267	0.3056	0.2028	-0.4420	*****	*****	*****	*****	*****
-0.950	*****	0.2563	0.2809	0.2191	-0.3952	*****	*****	*****	*****	*****
-0.975	-0.2063	0.0367	0.1510	0.1865	-0.1206	*****	*****	*****	*****	*****
-1.000	*****	-0.3307	-0.0843	0.0749	0.0020	*****	*****	*****	*****	*****
	-5.2105	-2.2182	-1.5395	-0.9417	-0.5050	*****	*****	*****	*****	*****

Medium Radius L.E.
 Run No. = 21, Point No. = 424
 $C_N = 0.736$, $C_m = -0.0994$
 $\alpha = 18.3^\circ$, $M_\infty = 0.398$
 $R_{mac} = 59.6 \times 10^6$



x/c_R	starb'd C_p	port C_p
0.10	-3.0883	*****
0.20	-5.3724	-5.2105
0.30	-3.3042	*****
0.40	-2.1847	-2.2182
0.50	-1.7459	*****
0.60	-1.2939	-1.5395
0.70	-0.9150	*****
0.80	-0.8261	-0.9417
0.90	*****	*****
0.95	-0.4519	-0.5050

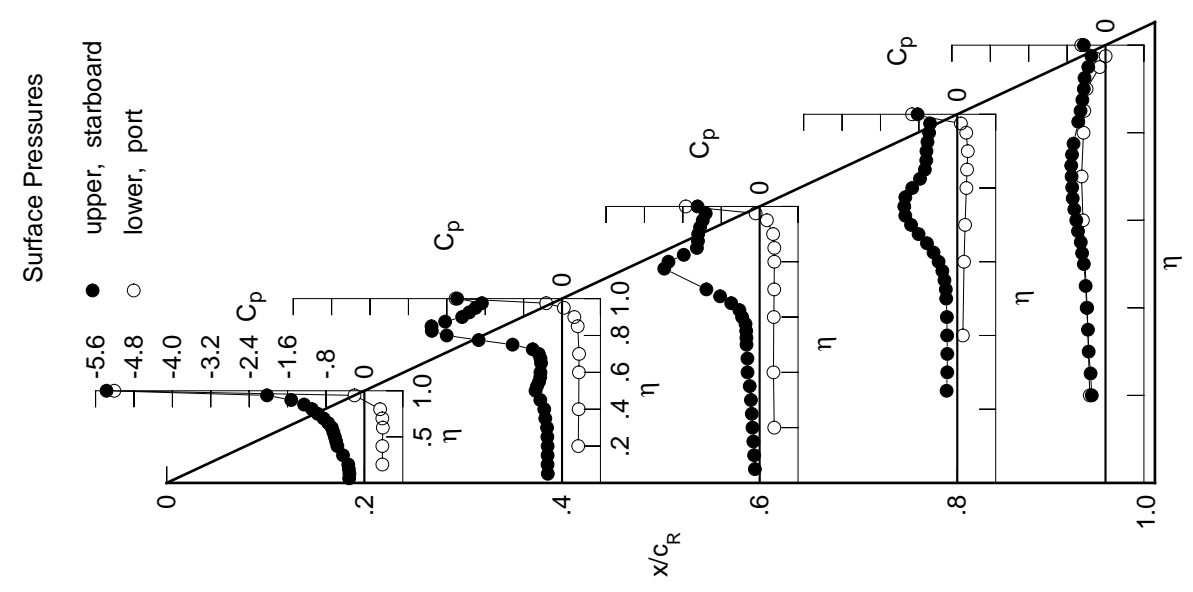
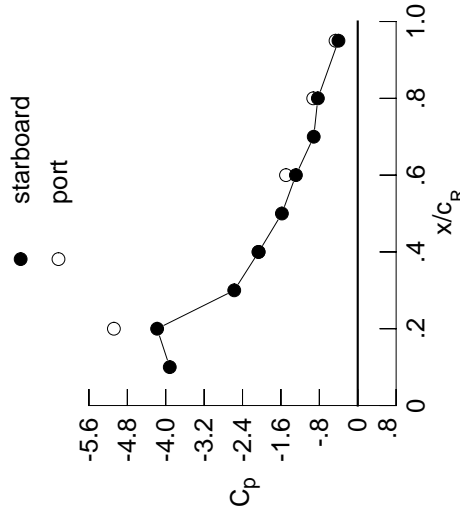

Table C2. Continued.

η	$x/c_R = .2$		$x/c_R = .4$		$x/c_R = .6$		$x/c_R = .8$		$x/c_R = .95$	
	$C_{p,u}$	$C_{p,u}$	$C_{p,u}$	$C_{p,u}$	$C_{p,u}$	$C_{p,u}$	$C_{p,u}$	$C_{p,u}$	$C_{p,u}$	$C_{p,u}$
0.050	-0.3962	-0.3716	-0.1380	*****	*****	*****	*****	*****	*****	*****
0.100	-0.3876	-0.3776	-0.1548	*****	*****	*****	*****	*****	*****	*****
0.150	-0.4050	-0.3749	-0.1687	*****	*****	*****	*****	*****	*****	*****
0.200	-0.4112	-0.3697	-0.1841	*****	*****	*****	*****	*****	*****	-0.3084
0.250	*****	-0.3788	-0.2035	-0.2637	-0.3220	*****	*****	*****	*****	*****
0.300	-0.5154	-0.4042	-0.2234	-0.2508	-0.3646	*****	*****	*****	*****	*****
0.350	*****	-0.4549	-0.2633	-0.2575	-0.3867	*****	*****	*****	*****	*****
0.400	-0.6641	-0.5432	-0.2990	-0.2695	-0.4299	*****	*****	*****	*****	*****
0.450	-0.6560	-0.5106	-0.2964	-0.3061	-0.4719	*****	*****	*****	*****	*****
0.500	-0.7068	-0.4844	-0.3448	-0.3837	-0.5387	*****	*****	*****	*****	*****
0.525	*****	-0.5136	-0.3741	-0.4377	-0.5903	*****	*****	*****	*****	*****
0.550	-0.8722	-0.5264	-0.4206	-0.5278	-0.6297	*****	*****	*****	*****	*****
0.575	*****	-0.5331	-0.4927	-0.6351	-0.7010	*****	*****	*****	*****	*****
0.600	-1.0156	-0.5755	-0.6582	-0.7705	-0.7404	*****	*****	*****	*****	*****
0.625	*****	*****	-0.7953	-0.9004	-0.7845	*****	*****	*****	*****	*****
0.650	-1.0661	-0.7943	-1.0755	-1.0324	-0.8106	*****	*****	*****	*****	*****
0.675	*****	-1.0360	-1.3899	-1.1451	-0.8125	*****	*****	*****	*****	*****
0.700	-1.0205	-1.3995	-1.6699	-1.2207	-0.8079	*****	*****	*****	*****	*****
0.725	*****	-1.8519	*****	-1.2396	-0.7898	*****	*****	*****	*****	*****
0.750	-1.0010	-2.3287	*****	-1.1789	-0.7288	*****	*****	*****	*****	*****
0.775	*****	-2.6965	-1.8505	-1.0713	-0.6449	*****	*****	*****	*****	*****
0.800	-1.0945	-2.8131	-1.4684	-0.8932	*****	*****	*****	*****	*****	*****
0.825	*****	-2.5840	-1.2800	-0.7910	-0.4965	*****	*****	*****	*****	*****
0.850	-2.0182	-2.2327	-1.2482	-0.7468	-0.4620	*****	*****	*****	*****	*****
0.875	*****	-2.0714	-1.2652	-0.7288	-0.4267	*****	*****	*****	*****	*****
0.900	-3.0544	-2.0149	-1.2466	-0.7230	-0.3904	*****	*****	*****	*****	*****
0.925	*****	-1.9051	-1.2201	-0.7004	-0.3864	*****	*****	*****	*****	*****
0.950	-2.8842	-1.7978	-1.2059	-0.6636	-0.3246	*****	*****	*****	*****	*****
0.975	*****	-1.7159	-1.1573	-0.6424	-0.2664	*****	*****	*****	*****	*****
1.000	-4.1791	-2.0628	-1.2880	-0.8307	-0.4017	*****	*****	*****	*****	*****
-0.200	$C_{p,l}$	$C_{p,l}$	$C_{p,l}$	$C_{p,l}$	$C_{p,l}$	$C_{p,l}$	$C_{p,l}$	$C_{p,l}$	$C_{p,l}$	$C_{p,l}$
-0.400	0.4273	0.3810	0.3391	*****	*****	*****	*****	*****	*****	-0.3215
-0.600	0.4271	0.3903	0.3231	0.1423	-0.3836	*****	*****	*****	*****	*****
-0.700	0.4312	0.3923	0.3266	0.1689	-0.4770	*****	*****	*****	*****	*****
-0.800	0.4094	0.3890	0.3357	0.1881	-0.5016	*****	*****	*****	*****	*****
-0.850	0.3421	*****	0.3311	0.2156	-0.4498	*****	*****	*****	*****	*****
-0.900	*****	0.3360	0.3234	0.2248	-0.4253	*****	*****	*****	*****	*****
-0.950	*****	0.2427	0.2809	0.2329	-0.3667	*****	*****	*****	*****	*****
-0.975	-0.2896	-0.0207	0.1137	0.1748	-0.0940	*****	*****	*****	*****	*****
-1.000	*****	-0.4320	-0.1643	0.0317	0.0084	*****	*****	*****	*****	*****
	-5.0801	-2.0686	-1.4947	-0.9269	-0.4622	*****	*****	*****	*****	*****

Medium Radius L.E.
 Run No. = 21, Point No. = 425
 $C_N = 0.860$, $C_m = -0.1144$
 $\alpha = 20.4^\circ$, $M_\infty = 0.397$
 $R_{mac} = 59.5 \times 10^6$

Leading Edge Pressures



x/c_R	starb'd C_p	port C_p
0.10	-3.9162	*****
0.20	-4.1791	-5.0801
0.30	-2.5726	*****
0.40	-2.0628	-2.0686
0.50	-1.5799	*****
0.60	-1.2880	-1.4947
0.70	-0.9166	*****
0.80	-0.8307	-0.9269
0.90	*****	*****
0.95	-0.4017	-0.4622

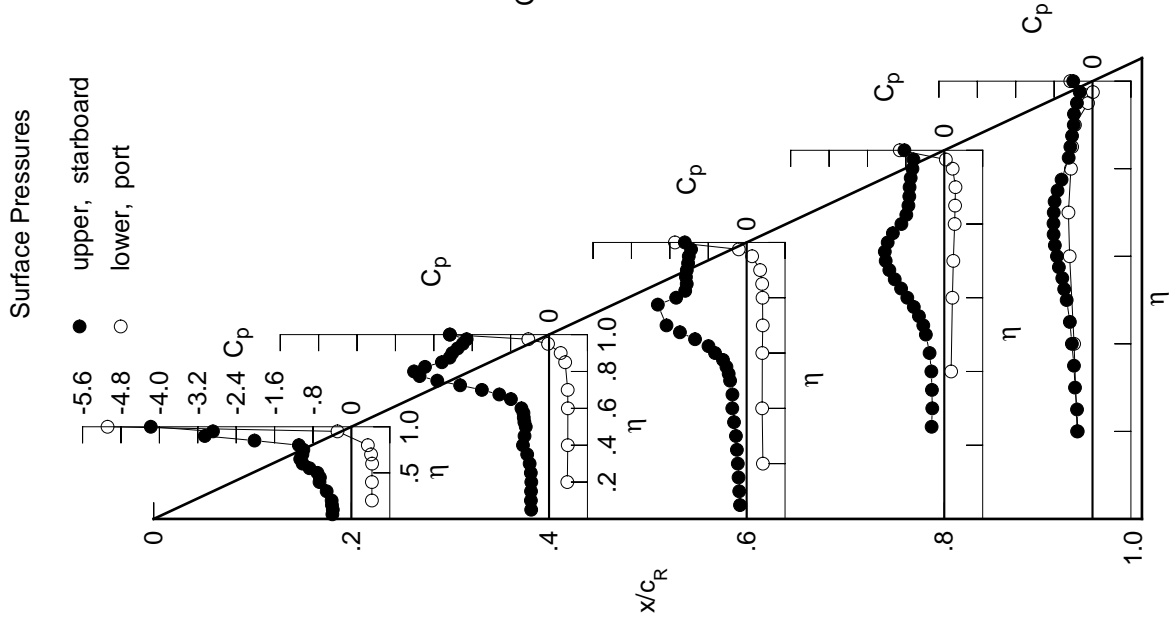
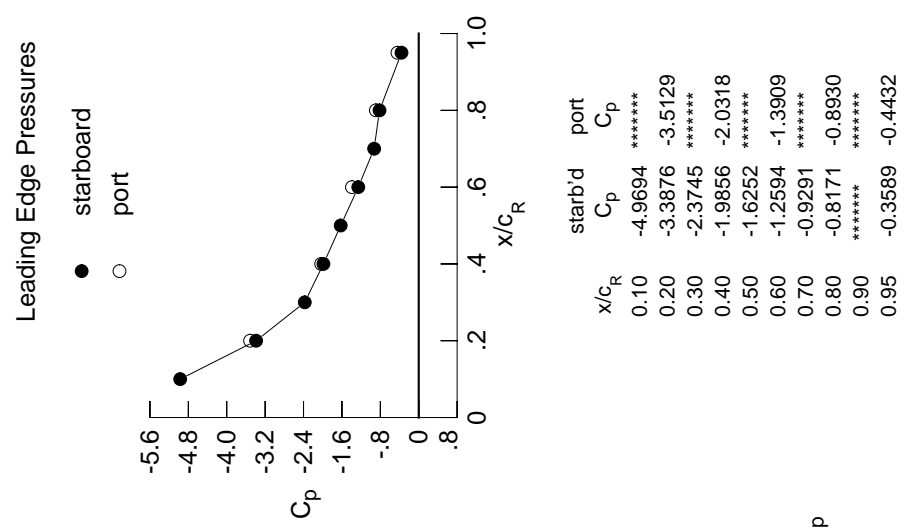

Table C2. Continued.

η	$x/c_R = .2$		$x/c_R = .4$		$x/c_R = .6$		$x/c_R = .8$		$x/c_R = .95$	
	$C_{p,u}$	$C_{p,u}$	$C_{p,u}$	$C_{p,u}$	$C_{p,u}$	$C_{p,u}$	$C_{p,u}$	$C_{p,u}$	$C_{p,l}$	$C_{p,l}$
0.050	-0.4967	-0.4443	-0.1785	*****	*****	*****	*****	*****	*****	*****
0.100	-0.4899	-0.4428	-0.1922	*****	*****	*****	*****	*****	*****	*****
0.150	-0.5083	-0.4413	-0.2094	*****	*****	*****	*****	*****	*****	*****
0.200	-0.5235	-0.4369	-0.2275	*****	*****	*****	*****	*****	*****	*****
0.250	*****	-0.4608	-0.2501	-0.3015	-0.3435	*****	*****	*****	*****	*****
0.300	-0.6234	-0.5382	-0.2773	-0.2942	-0.3683	*****	*****	*****	*****	*****
0.350	*****	-0.5343	-0.3236	-0.3066	-0.3923	*****	*****	*****	*****	*****
0.400	-0.7436	-0.5218	-0.3588	-0.3301	-0.4482	*****	*****	*****	*****	*****
0.450	-0.9191	-0.5323	-0.3852	-0.3982	-0.5103	*****	*****	*****	*****	*****
0.500	-0.8083	-0.5544	-0.5021	-0.5267	-0.6057	*****	*****	*****	*****	*****
0.525	*****	-0.5961	-0.5936	-0.6191	-0.6717	*****	*****	*****	*****	*****
0.550	-0.7495	-0.6475	-0.7212	-0.7414	-0.7281	*****	*****	*****	*****	*****
0.575	*****	-0.7189	-0.8919	-0.8832	-0.8053	*****	*****	*****	*****	*****
0.600	-0.7506	-0.8538	-1.1761	-1.0360	-0.8590	*****	*****	*****	*****	*****
0.625	*****	*****	-1.4128	-1.1737	-0.9021	*****	*****	*****	*****	*****
0.650	-0.7329	-1.4142	-1.7435	-1.2960	-0.9265	*****	*****	*****	*****	*****
0.675	*****	-1.8993	-2.0307	-1.3851	-0.9074	*****	*****	*****	*****	*****
0.700	-0.7486	-2.4219	-2.1442	-1.4236	-0.8774	*****	*****	*****	*****	*****
0.725	*****	-2.8774	*****	-1.3969	-0.8159	*****	*****	*****	*****	*****
0.750	-2.1289	-3.1356	*****	-1.2834	-0.6998	*****	*****	*****	*****	*****
0.775	*****	-2.9239	-1.6523	-1.1183	-0.5622	*****	*****	*****	*****	*****
0.800	-3.4771	-2.3240	-1.3765	-0.9144	*****	*****	*****	*****	*****	*****
0.825	*****	-2.0368	-1.3162	-0.8187	-0.4227	*****	*****	*****	*****	*****
0.850	-3.4902	-2.0102	-1.3062	-0.7925	-0.4125	*****	*****	*****	*****	*****
0.875	*****	-2.0272	-1.3169	-0.7773	-0.3872	*****	*****	*****	*****	*****
0.900	-3.1448	-1.9896	-1.3086	-0.7748	-0.3599	*****	*****	*****	*****	*****
0.925	*****	-1.8625	-1.2498	-0.7507	-0.3624	*****	*****	*****	*****	*****
0.950	-2.6994	-1.8013	-1.1989	-0.7146	-0.3202	*****	*****	*****	*****	*****
0.975	*****	-1.7601	-1.1688	-0.6955	-0.2615	*****	*****	*****	*****	*****
1.000	-3.3876	-1.9856	-1.2594	-0.8171	-0.3589	*****	*****	*****	*****	*****
-0.200	$C_{p,l}$	$C_{p,l}$	$C_{p,l}$	$C_{p,l}$	$C_{p,l}$	$C_{p,l}$	$C_{p,l}$	$C_{p,l}$	$C_{p,l}$	$C_{p,l}$
-0.400	0.4798	0.4253	0.3748	*****	*****	*****	*****	*****	*****	*****
-0.600	0.4785	0.4317	0.3601	0.1732	-0.3876	*****	*****	*****	*****	*****
-0.700	0.4735	0.4307	0.3615	0.1966	-0.4792	*****	*****	*****	*****	*****
-0.800	0.4415	0.4240	0.3690	0.2166	-0.4949	*****	*****	*****	*****	*****
-0.850	0.3531	*****	0.3592	0.2401	-0.4306	*****	*****	*****	*****	*****
-0.900	*****	0.3420	0.3438	0.2477	-0.3991	*****	*****	*****	*****	*****
-0.950	*****	0.2230	0.2855	0.2477	-0.3333	*****	*****	*****	*****	*****
-0.975	-0.3550	-0.0861	0.0835	0.1647	-0.0681	*****	*****	*****	*****	*****
-1.000	*****	-0.5439	-0.2285	-0.0070	0.0109	*****	*****	*****	*****	*****
	-3.5129	-2.0318	-1.3909	-0.8930	-0.4432	*****	*****	*****	*****	*****

Medium Radius L.E.
 Run No. = 21, Point No. = 426
 $C_N = 0.986$, $C_m = -0.1291$
 $\alpha = 22.4^\circ$, $M_\infty = 0.398$
 $R_{mac} = 59.6 \times 10^6$



x/c_R	starb'd C_p	port C_p
0.10	-4.9694	*****
0.20	-3.3876	-3.5129
0.30	-2.3745	*****
0.40	-1.9856	-2.0318
0.50	-1.6252	*****
0.60	-1.2594	-1.3909
0.70	-0.9291	*****
0.80	-0.8171	-0.8930
0.90	*****	*****
0.95	-0.3589	-0.4432

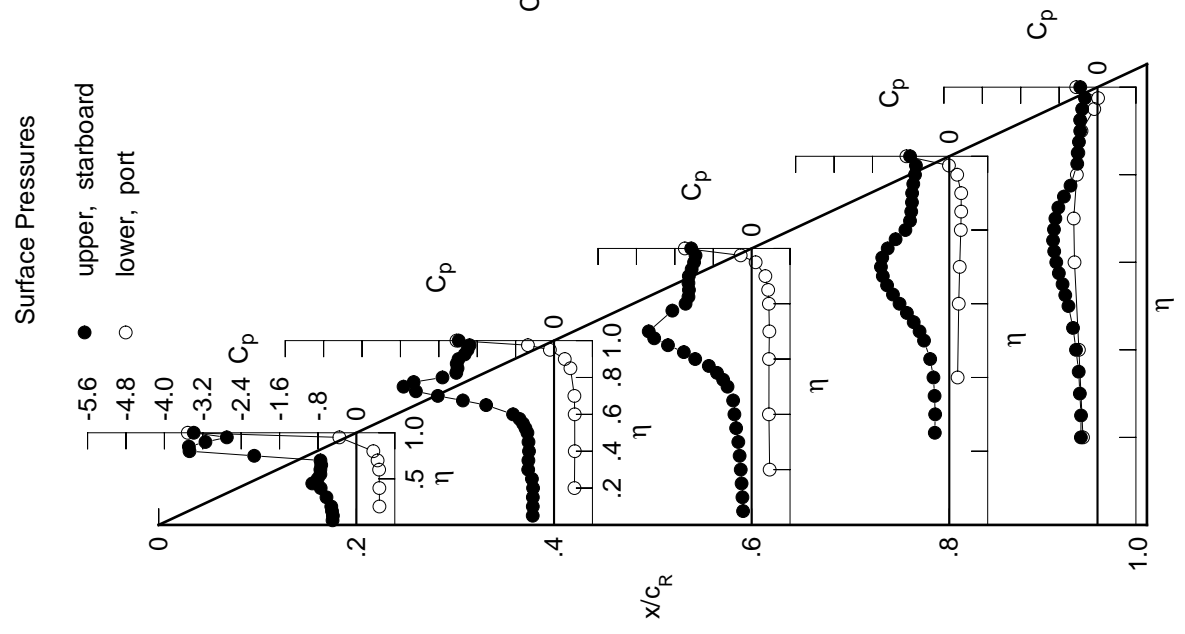
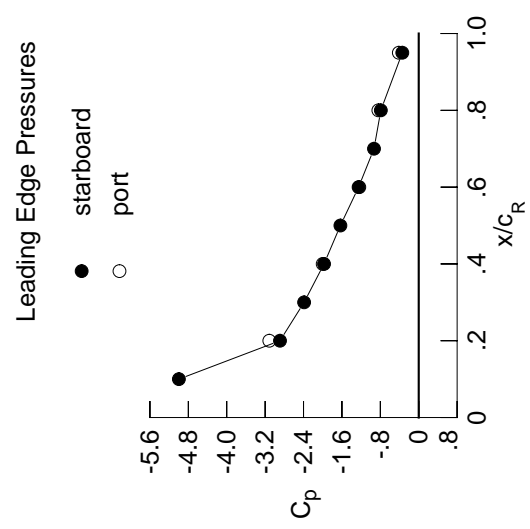

Table C2. Continued.

η	$x/c_R = .2$		$x/c_R = .4$		$x/c_R = .6$		$x/c_R = .8$		$x/c_R = .95$	
	$C_{p,u}$	$C_{p,u}$	$C_{p,u}$	$C_{p,u}$	$C_{p,u}$	$C_{p,u}$	$C_{p,u}$	$C_{p,u}$	$C_{p,u}$	$C_{p,u}$
0.050	-0.5987	-0.5113	-0.2112	*****	*****	*****	*****	*****	*****	*****
0.100	-0.5942	-0.5121	-0.2294	*****	*****	*****	*****	*****	*****	*****
0.150	-0.6096	-0.5078	-0.2469	*****	*****	*****	*****	*****	*****	*****
0.200	-0.6637	-0.4999	-0.2686	*****	*****	*****	*****	*****	*****	-0.3780
0.250	*****	-0.5378	-0.2948	-0.3521	-0.3888	*****	*****	*****	*****	-0.3888
0.300	-0.7613	-0.6018	-0.3244	-0.3517	-0.4029	*****	*****	*****	*****	-0.4029
0.350	*****	-0.5965	-0.3654	-0.3792	-0.4234	*****	*****	*****	*****	-0.4234
0.400	-0.7790	-0.6063	-0.4255	-0.4240	-0.4879	*****	*****	*****	*****	-0.4879
0.450	-0.7554	-0.6449	-0.5104	-0.5283	-0.5667	*****	*****	*****	*****	-0.5667
0.500	-0.7670	-0.7294	-0.7210	-0.6991	-0.6796	*****	*****	*****	*****	-0.6796
0.525	*****	-0.8383	-0.8743	-0.8110	-0.7489	*****	*****	*****	*****	-0.7489
0.550	-0.7662	-0.9741	-1.0623	-0.9442	-0.8042	*****	*****	*****	*****	-0.8042
0.575	*****	-1.1566	-1.2991	-1.0902	-0.8746	*****	*****	*****	*****	-0.8746
0.600	-0.7544	-1.4348	-1.6189	-1.2355	-0.9155	*****	*****	*****	*****	-0.9155
0.625	*****	*****	-1.8551	-1.3564	-0.9417	*****	*****	*****	*****	-0.9417
0.650	-0.9793	-2.2614	-2.1370	-1.4399	-0.9427	*****	*****	*****	*****	-0.9427
0.675	*****	-2.7983	-2.3045	-1.4934	-0.8987	*****	*****	*****	*****	-0.8987
0.700	-2.1746	-3.1959	-2.2591	-1.4938	-0.8385	*****	*****	*****	*****	-0.8385
0.725	*****	-3.2961	*****	-1.4343	-0.7471	*****	*****	*****	*****	-0.7471
0.750	-3.8071	-3.0047	*****	-1.2826	-0.5999	*****	*****	*****	*****	-0.5999
0.775	*****	-2.4038	-1.5099	-1.1017	-0.4731	*****	*****	*****	*****	-0.4731
0.800	-4.1353	-2.0907	-1.3417	-0.9158	*****	*****	*****	*****	*****	-0.9158
0.825	*****	-2.0541	-1.3092	-0.8521	-0.4330	*****	*****	*****	*****	-0.4330
0.850	-3.4271	-2.0551	-1.2845	-0.8348	-0.4296	*****	*****	*****	*****	-0.4296
0.875	*****	-2.0731	-1.2910	-0.8255	-0.4117	*****	*****	*****	*****	-0.4117
0.900	-2.9379	-2.0281	-1.2879	-0.8196	-0.3828	*****	*****	*****	*****	-0.3828
0.925	*****	-1.9203	-1.2482	-0.8011	-0.3987	*****	*****	*****	*****	-0.3987
0.950	-2.5824	-1.8701	-1.2120	-0.7588	-0.3472	*****	*****	*****	*****	-0.3472
0.975	*****	-1.8423	-1.1973	-0.7262	-0.2777	*****	*****	*****	*****	-0.2777
1.000	-2.8907	-1.9731	-1.2531	-0.7896	-0.3423	*****	*****	*****	*****	-0.3423
-0.200	$C_{p,l}$	$C_{p,l}$	$C_{p,l}$	$C_{p,l}$	$C_{p,l}$	$C_{p,l}$	$C_{p,l}$	$C_{p,l}$	$C_{p,l}$	$C_{p,l}$
-0.400	0.5329	0.4709	0.4125	*****	*****	*****	*****	*****	*****	-0.3000
-0.600	0.5267	0.4754	0.3977	0.2029	-0.3978	*****	*****	*****	*****	-0.3978
-0.700	0.5118	0.4706	0.3989	0.2258	-0.4856	*****	*****	*****	*****	-0.4856
-0.800	0.4659	0.4568	0.4018	0.2436	-0.4898	*****	*****	*****	*****	-0.4898
-0.850	0.3537	*****	0.3846	0.2648	-0.4152	*****	*****	*****	*****	-0.4152
-0.900	*****	0.3455	0.3609	0.2677	-0.3789	*****	*****	*****	*****	-0.3789
-0.950	*****	0.2020	0.2873	0.2580	-0.3048	*****	*****	*****	*****	-0.3048
-0.975	-0.4493	-0.1535	0.0552	0.1503	-0.0466	*****	*****	*****	*****	-0.0466
-1.000	*****	-0.6572	-0.2812	-0.0484	0.0112	*****	*****	*****	*****	0.0112
	-3.1131	-2.0008	-1.2384	-0.8407	-0.4143	*****	*****	*****	*****	-0.4143

Medium Radius L.E.
 Run No. = 21, Point No. = 427
 $C_N = 1.101$, $C_m = -0.1444$
 $\alpha = 24.5^\circ$, $M_\infty = 0.397$
 $R_{mac} = 59.5 \times 10^6$



x/c_R	starb'd C_p	port C_p
0.10	-4.9969	*****
0.20	-2.8907	-3.1131
0.30	-2.3879	*****
0.40	-1.9731	-2.0008
0.50	-1.6321	*****
0.60	-1.2531	-1.2384
0.70	-0.9318	*****
0.80	-0.7896	-0.8407
0.90	*****	*****
0.95	-0.3423	-0.4143

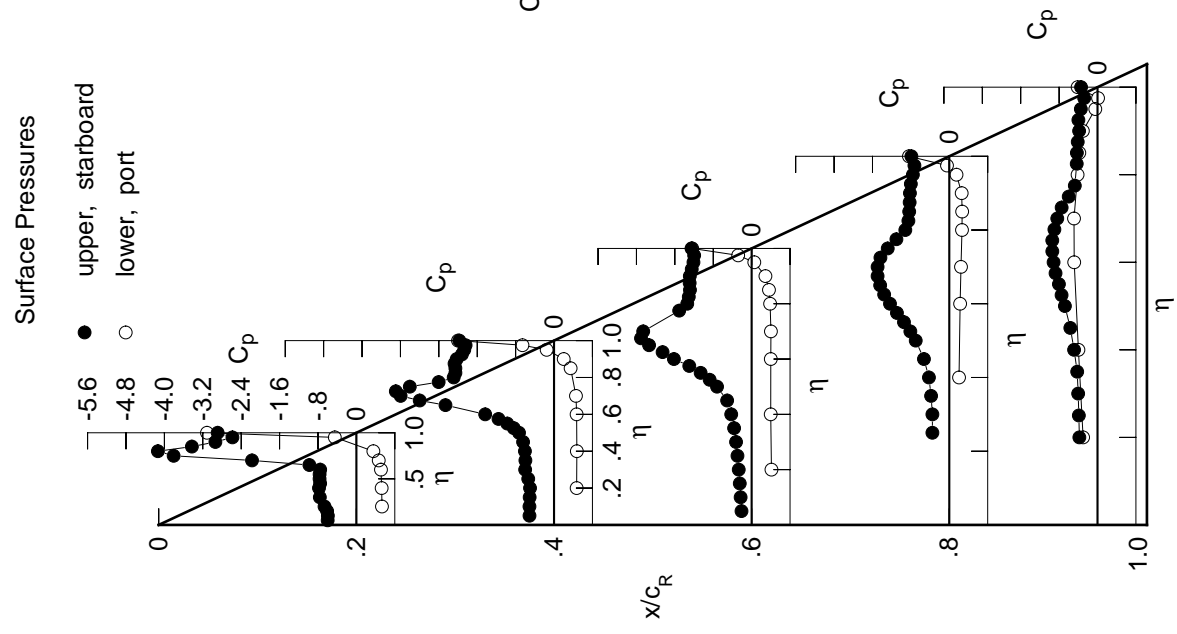
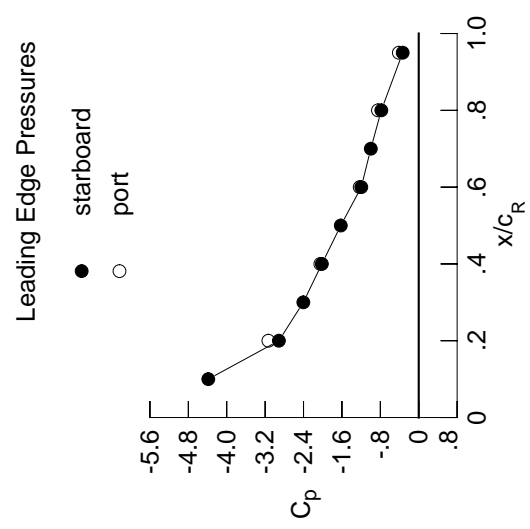

Table C2. Concluded.

η	x/c_R .2	x/c_R .4	x/c_R .6	x/c_R .8	x/c_R .95
	$C_{p,u}$	$C_{p,u}$	$C_{p,u}$	$C_{p,u}$	$C_{p,u}$
0.050	-0.7109	-0.5883	-0.2470	*****	*****
0.100	-0.7031	-0.5906	-0.2667	*****	*****
0.150	-0.7350	-0.5884	-0.2865	*****	*****
0.200	-0.7684	-0.5839	-0.3124	*****	-0.3874
0.250	*****	-0.6072	-0.3443	-0.4180	-0.4257
0.300	-0.8865	-0.6533	-0.3823	-0.4335	-0.4479
0.350	*****	-0.7030	-0.4365	-0.4856	-0.4743
0.400	-0.8449	-0.7512	-0.5208	-0.5576	-0.5469
0.450	-0.8552	-0.8579	-0.6522	-0.7008	-0.6358
0.500	-0.8765	-1.0502	-0.9363	-0.8956	-0.7567
0.525	*****	-1.2414	-1.1369	-1.0093	-0.8195
0.550	-0.9377	-1.4724	-1.3638	-1.1290	-0.8667
0.575	*****	-1.7453	-1.6245	-1.2462	-0.9188
0.600	-1.2773	-2.0990	-1.9395	-1.3535	-0.9429
0.625	*****	*****	-2.1375	-1.4221	-0.9445
0.650	-2.3426	-2.9181	-2.3245	-1.4602	-0.9238
0.675	*****	-3.2876	-2.3750	-1.4662	-0.8584
0.700	-3.6553	-3.3662	-2.2209	-1.4286	-0.7795
0.725	*****	-3.1155	*****	-1.3449	-0.6737
0.750	-4.3469	-2.6363	*****	-1.1866	-0.5332
0.775	*****	-2.2293	-1.4179	-1.0208	-0.4361
0.800	-3.4433	-2.1405	-1.3136	-0.9039	*****
0.825	*****	-2.1334	-1.2856	-0.8777	-0.4258
0.850	-3.0902	-2.1377	-1.2634	-0.8711	-0.4297
0.875	*****	-2.1504	-1.2592	-0.8628	-0.4133
0.900	-2.9190	-2.1004	-1.2573	-0.8646	-0.3884
0.925	*****	-2.0130	-1.2270	-0.8573	-0.4012
0.950	-2.7010	-1.9741	-1.1950	-0.8083	-0.3642
0.975	*****	-1.9511	-1.1764	-0.7575	-0.3015
1.000	-2.9139	-2.0180	-1.1965	-0.7794	-0.3344
	$C_{p,l}$	$C_{p,l}$	$C_{p,l}$	$C_{p,l}$	$C_{p,l}$
-0.200	0.5798	0.5135	0.4472	*****	-0.2922
-0.400	0.5707	0.5158	0.4329	0.2342	-0.3863
-0.600	0.5430	0.5047	0.4313	0.2554	-0.4755
-0.700	0.4829	0.4843	0.4309	0.2713	-0.4733
-0.800	0.3443	*****	0.4049	0.2888	-0.3901
-0.850	*****	0.3382	0.3701	0.2876	-0.3514
-0.900	*****	0.1649	0.2771	0.2660	-0.2722
-0.950	-0.5690	-0.2437	0.0052	0.1290	-0.0280
-0.975	*****	-0.8005	-0.3715	-0.1052	0.0042
-1.000	-3.1318	-2.0492	-1.2293	-0.8497	-0.4146

Medium Radius L.E.
 Run No. = 21, Point No. = 428
 $C_N = 1.213$, $C_m = -0.1537$
 $\alpha = 26.6^\circ$, $M_\infty = 0.398$
 $R_{mac} = 59.5 \times 10^6$



x/c_R	starb'd C_p	port C_p
0.10	-4.3843	*****
0.20	-2.9139	*****
0.30	-2.4039	*****
0.40	-2.0180	-2.0492
0.50	-1.6241	*****
0.60	-1.1965	-1.2293
0.70	-0.9986	*****
0.80	-0.7794	-0.8497
0.90	*****	*****
0.95	-0.3344	-0.4146

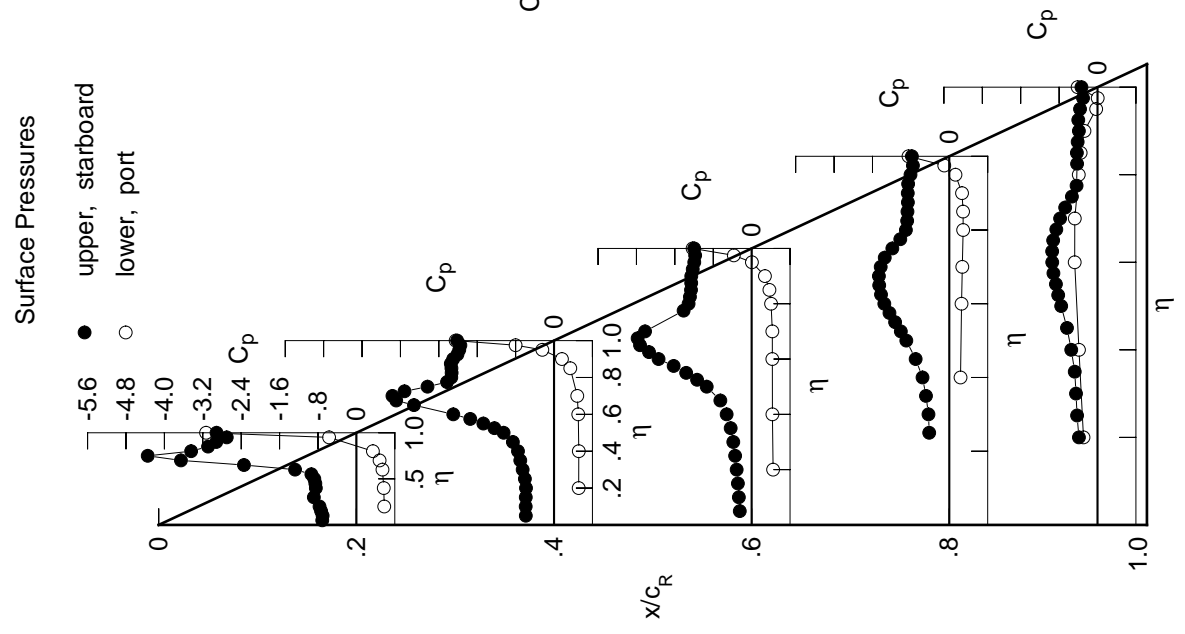
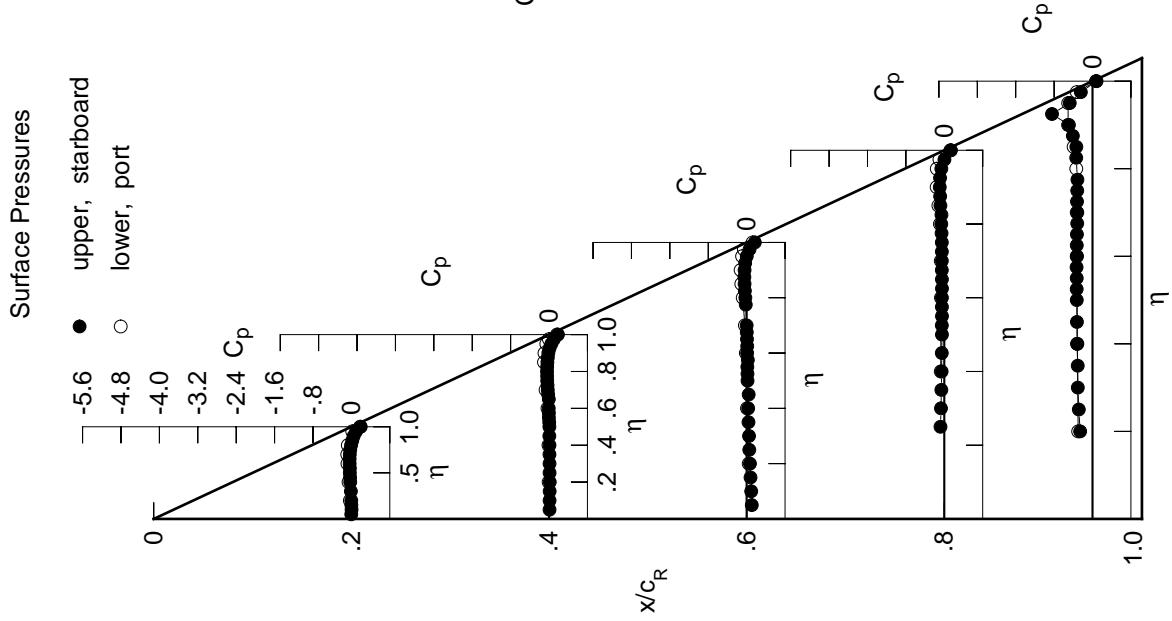

Table C3. Tabulations and Plots of Surface Pressure Coefficients.

η	$x/c_R = .2$		$x/c_R = .4$		$x/c_R = .6$		$x/c_R = .8$		$x/c_R = .95$	
	$C_{p,u}$	$C_{p,u}$	$C_{p,u}$	$C_{p,u}$	$C_{p,u}$	$C_{p,u}$	$C_{p,u}$	$C_{p,u}$	$C_{p,u}$	$C_{p,u}$
0.050	-0.0020	0.0106	0.1074	*****	*****	*****	*****	*****	*****	*****
0.100	0.0029	0.0116	0.0955	*****	*****	*****	*****	*****	*****	*****
0.150	-0.0003	0.0127	0.0812	*****	*****	*****	*****	*****	*****	*****
0.200	-0.0023	0.0152	0.0690	*****	*****	*****	*****	*****	*****	-0.2574
0.250	*****	0.0109	0.0553	-0.0791	-0.2857	*****	*****	*****	*****	-0.2857
0.300	-0.0106	0.0106	0.0493	-0.0688	-0.3065	*****	*****	*****	*****	-0.3065
0.350	*****	0.0087	0.0384	-0.0608	-0.3084	*****	*****	*****	*****	-0.3084
0.400	-0.0236	0.0100	0.0321	-0.0551	-0.3213	*****	*****	*****	*****	-0.3213
0.450	-0.0274	0.0062	0.0423	-0.0521	-0.3245	*****	*****	*****	*****	-0.3245
0.500	-0.0328	0.0071	0.0187	-0.0492	-0.3284	*****	*****	*****	*****	-0.3284
0.525	*****	0.0043	0.0177	-0.0514	-0.3298	*****	*****	*****	*****	-0.3298
0.550	-0.0310	-0.0033	0.0143	-0.0477	-0.3290	*****	*****	*****	*****	-0.3290
0.575	*****	-0.0030	0.0244	-0.0494	-0.3316	*****	*****	*****	*****	-0.3316
0.600	-0.0364	-0.0065	0.0098	-0.0492	-0.3295	*****	*****	*****	*****	-0.3295
0.625	*****	*****	0.0120	-0.0479	-0.3281	*****	*****	*****	*****	-0.3281
0.650	-0.0370	-0.0049	0.0071	-0.0500	-0.3251	*****	*****	*****	*****	-0.3251
0.675	*****	-0.0183	0.0031	-0.0513	-0.3181	*****	*****	*****	*****	-0.3181
0.700	-0.0339	-0.0260	0.0001	-0.0516	-0.3168	*****	*****	*****	*****	-0.3168
0.725	*****	-0.0314	*****	-0.0508	-0.3234	*****	*****	*****	*****	-0.3234
0.750	-0.0242	-0.0379	*****	-0.0514	-0.3187	*****	*****	*****	*****	-0.3187
0.775	*****	-0.0393	-0.0182	-0.0568	-0.3147	*****	*****	*****	*****	-0.3147
0.800	-0.0064	-0.0418	-0.0269	-0.0621	*****	*****	*****	*****	*****	*****
0.825	*****	-0.0392	-0.0369	-0.0591	-0.3395	*****	*****	*****	*****	-0.3395
0.850	0.0185	-0.0342	-0.0436	-0.0808	-0.3364	*****	*****	*****	*****	-0.3364
0.875	*****	-0.0256	-0.0474	-0.0863	-0.4100	*****	*****	*****	*****	-0.4100
0.900	0.0482	-0.0145	-0.0433	-0.0948	-0.4916	*****	*****	*****	*****	-0.4916
0.925	*****	0.0098	-0.0312	-0.0880	-0.8442	*****	*****	*****	*****	-0.8442
0.950	0.0971	0.0487	0.0020	-0.0614	-0.4747	*****	*****	*****	*****	-0.4747
0.975	*****	0.1014	0.0607	0.0033	-0.2432	*****	*****	*****	*****	-0.2432
1.000	0.1942	0.1855	0.1701	0.1380	0.0834	*****	*****	*****	*****	0.0834
η	$C_{p,l}$	$C_{p,l}$	$C_{p,l}$	$C_{p,l}$	$C_{p,l}$	$C_{p,l}$	$C_{p,l}$	$C_{p,l}$	$C_{p,l}$	$C_{p,l}$
-0.200	-0.0319	-0.0088	0.0434	*****	-0.2991	*****	*****	*****	*****	-0.2991
-0.400	-0.0588	-0.0122	0.0071	-0.0737	-0.3159	*****	*****	*****	*****	-0.3159
-0.600	-0.0827	-0.0331	-0.0167	-0.0695	-0.3235	*****	*****	*****	*****	-0.3235
-0.700	-0.0863	-0.0719	-0.0366	-0.0734	-0.3288	*****	*****	*****	*****	-0.3288
-0.800	-0.0744	*****	-0.0813	-0.0915	-0.3382	*****	*****	*****	*****	-0.3382
-0.850	*****	-0.1055	-0.1114	-0.1224	-0.3939	*****	*****	*****	*****	-0.3939
-0.900	*****	-0.0955	-0.1257	-0.1593	-0.5095	*****	*****	*****	*****	-0.5095
-0.950	0.0176	-0.0569	-0.0956	-0.1569	-0.5075	*****	*****	*****	*****	-0.5075
-0.975	*****	-0.0028	-0.0587	-0.1008	-0.3284	*****	*****	*****	*****	-0.3284
-1.000	0.1818	0.1635	0.1231	0.1284	0.0729	*****	*****	*****	*****	0.0729

Medium Radius L.E.
 Run No. = 29 , Point No. = 576
 $C_N = -0.020$, $C_m = -0.0048$
 $\alpha = -0.6^\circ$, $M_\infty = 0.399$
 $R_{mac} = 72.7 \times 10^6$



Leading Edge Pressures

● starboard
 ○ port

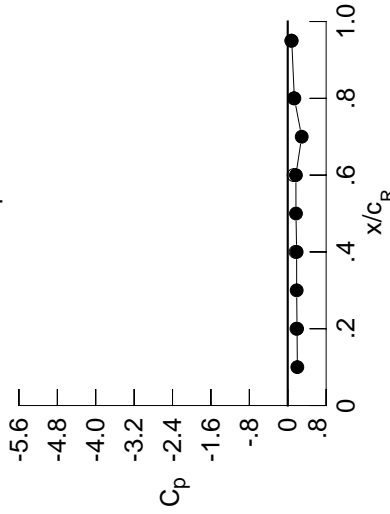

x/c_R	starb'd C_p	port C_p
0.10	0.2002	*****
0.20	0.1942	0.1818
0.30	0.1861	*****
0.40	0.1855	0.1635
0.50	0.1716	*****
0.60	0.1701	0.1231
0.70	0.2910	*****
0.80	0.1380	0.1284
0.90	*****	*****
0.95	0.0834	0.0729

Table C3. Continued.

η	$x/c_R = .2$		$x/c_R = .4$		$x/c_R = .6$		$x/c_R = .8$		$x/c_R = .95$	
	$C_{p,u}$	$C_{p,u}$	$C_{p,u}$	$C_{p,u}$	$C_{p,u}$	$C_{p,u}$	$C_{p,u}$	$C_{p,u}$	$C_{p,u}$	$C_{p,u}$
0.050	-0.0086	0.0050	0.1032	*****	*****	*****	*****	*****	*****	
0.100	-0.0041	0.0062	0.0911	*****	*****	*****	*****	*****	*****	
0.150	-0.0083	0.0070	0.0776	*****	*****	*****	*****	*****	*****	
0.200	-0.0096	0.0089	0.0640	*****	*****	*****	*****	*****	*****	
0.250	*****	0.0052	0.0504	-0.0816	-0.2840	*****	*****	*****	*****	
0.300	-0.0172	0.0054	0.0449	-0.0715	-0.3039	*****	*****	*****	*****	
0.350	*****	0.0034	0.0329	-0.0642	-0.3052	*****	*****	*****	*****	
0.400	-0.0317	0.0028	0.0274	-0.0578	-0.3175	*****	*****	*****	*****	
0.450	-0.0362	-0.0001	0.0364	-0.0562	-0.3223	*****	*****	*****	*****	
0.500	-0.0422	-0.0008	0.0136	-0.0518	-0.3268	*****	*****	*****	*****	
0.525	*****	-0.0029	0.0109	-0.0556	-0.3281	*****	*****	*****	*****	
0.550	-0.0409	-0.0107	0.0099	-0.0506	-0.3270	*****	*****	*****	*****	
0.575	*****	-0.0114	0.0176	-0.0533	-0.3305	*****	*****	*****	*****	
0.600	-0.0478	-0.0137	0.0026	-0.0537	-0.3283	*****	*****	*****	*****	
0.625	*****	*****	0.0041	-0.0524	-0.3261	*****	*****	*****	*****	
0.650	-0.0488	-0.0131	0.0012	-0.0539	-0.3226	*****	*****	*****	*****	
0.675	*****	-0.0274	-0.0046	-0.0563	-0.3155	*****	*****	*****	*****	
0.700	-0.0462	-0.0366	-0.0066	-0.0556	-0.3154	*****	*****	*****	*****	
0.725	*****	-0.0418	*****	-0.0566	-0.3197	*****	*****	*****	*****	
0.750	-0.0369	-0.0499	*****	-0.0559	-0.3158	*****	*****	*****	*****	
0.775	*****	-0.0521	-0.0275	-0.0632	-0.3104	*****	*****	*****	*****	
0.800	-0.0203	-0.0545	-0.0382	-0.0688	*****	*****	*****	*****	*****	
0.825	*****	-0.0541	-0.0486	-0.0679	-0.3365	*****	*****	*****	*****	
0.850	0.0039	-0.0514	-0.0574	-0.0888	-0.3356	*****	*****	*****	*****	
0.875	*****	-0.0431	-0.0616	-0.0995	-0.4098	*****	*****	*****	*****	
0.900	0.0320	-0.0334	-0.0600	-0.1079	-0.4926	*****	*****	*****	*****	
0.925	*****	-0.0094	-0.0496	-0.1045	-0.8549	*****	*****	*****	*****	
0.950	0.0809	0.0273	-0.0181	-0.0787	-0.4879	*****	*****	*****	*****	
0.975	*****	0.0810	0.0384	-0.0192	-0.2601	*****	*****	*****	*****	
1.000	0.2001	0.1955	0.1894	0.1513	0.0902	*****	*****	*****	*****	
-0.200	$C_{p,l}$	$C_{p,l}$	$C_{p,l}$	$C_{p,l}$	$C_{p,l}$	$C_{p,l}$	$C_{p,l}$	$C_{p,l}$	$C_{p,l}$	
-0.400	-0.0251	-0.0047	0.0472	*****	-0.2997	*****	*****	*****	*****	
-0.600	-0.0515	-0.0060	0.0115	-0.0710	-0.3167	*****	*****	*****	*****	
-0.700	-0.0741	-0.0619	-0.0293	-0.0695	-0.3299	*****	*****	*****	*****	
-0.800	-0.0608	*****	-0.0722	-0.0848	-0.3394	*****	*****	*****	*****	
-0.850	*****	-0.0908	-0.0996	-0.1133	-0.3953	*****	*****	*****	*****	
-0.900	*****	-0.0785	-0.1103	-0.1469	-0.5077	*****	*****	*****	*****	
-0.950	0.0359	-0.0360	-0.0751	-0.1376	-0.4945	*****	*****	*****	*****	
-0.975	*****	0.0236	-0.0338	-0.0766	-0.3106	*****	*****	*****	*****	
-1.000	0.1894	0.1773	0.1400	0.1489	0.0855	*****	*****	*****	*****	

Medium Radius L.E.
 Run No. = 29 , Point No. = 577
 $C_N = -0.010$, $C_m = -0.0044$
 $\alpha = -0.3^\circ$, $M_\infty = 0.399$
 $R_{mac} = 72.7 \times 10^6$

Leading Edge Pressures

● starboard
 ○ port

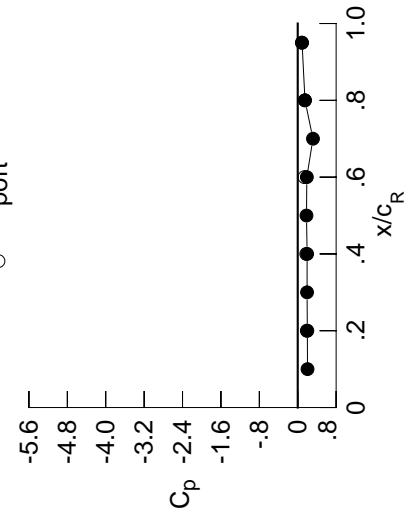

x/c_R	starb'd C_p	port C_p
0.10	0.2037	*****
0.20	0.2001	0.1894
0.30	0.1945	*****
0.40	0.1955	0.1773
0.50	0.1826	*****
0.60	0.1894	0.1400
0.70	0.3173	*****
0.80	0.1513	0.1489
0.90	*****	*****
0.95	0.0902	0.0855

Surface Pressures

● upper, starboard
 ○ lower, port

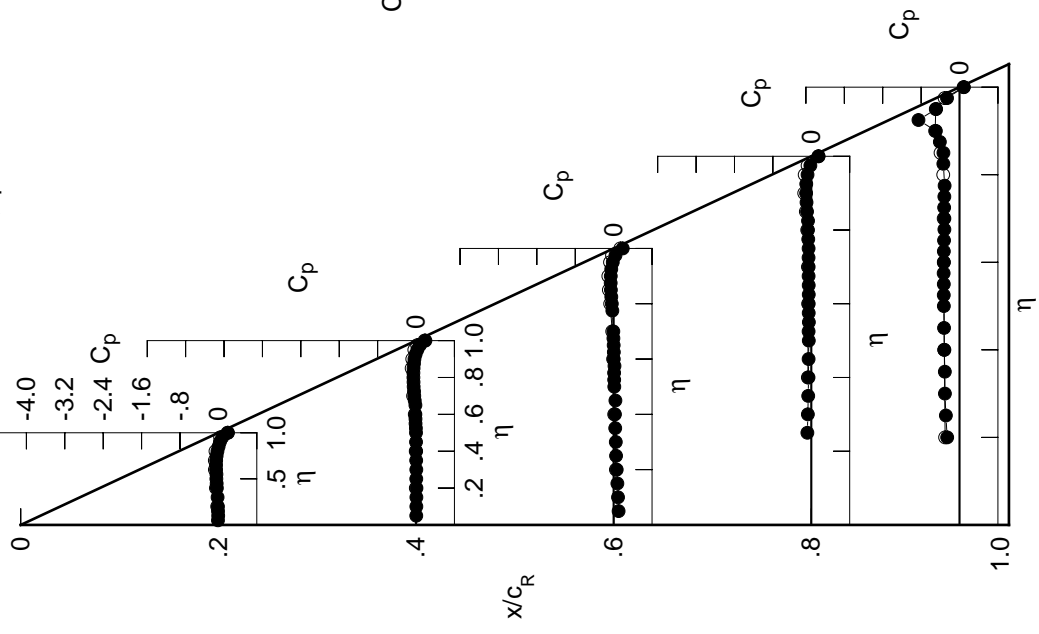

Table C3. Continued.

η	$x/c_R = .2$		$x/c_R = .4$		$x/c_R = .6$		$x/c_R = .8$		$x/c_R = .95$	
	$C_{p,u}$	$C_{p,u}$	$C_{p,u}$	$C_{p,u}$	$C_{p,u}$	$C_{p,u}$	$C_{p,u}$	$C_{p,u}$	$C_{p,u}$	$C_{p,u}$
0.050	-0.0291	-0.0089	0.0939	0.0939	0.0939	0.0939	0.0939	0.0939	0.0939	0.0939
0.100	-0.0229	-0.0088	0.0817	0.0817	0.0817	0.0817	0.0817	0.0817	0.0817	0.0817
0.150	-0.0257	-0.0068	0.0682	0.0682	0.0682	0.0682	0.0682	0.0682	0.0682	0.0682
0.200	-0.0281	-0.0063	0.0531	0.0531	0.0531	0.0531	0.0531	0.0531	0.0531	0.0531
0.250	0.0000	-0.0106	0.0408	0.0408	0.0408	0.0408	0.0408	0.0408	0.0408	0.0408
0.300	-0.0370	-0.0115	0.0325	0.0325	0.0325	0.0325	0.0325	0.0325	0.0325	0.0325
0.350	0.0000	-0.0118	0.0222	0.0222	0.0222	0.0222	0.0222	0.0222	0.0222	0.0222
0.400	-0.0541	-0.0141	0.0149	0.0149	0.0149	0.0149	0.0149	0.0149	0.0149	0.0149
0.450	-0.0598	-0.0178	0.0254	0.0254	0.0254	0.0254	0.0254	0.0254	0.0254	0.0254
0.500	-0.0672	-0.0190	-0.0009	-0.0603	-0.0603	-0.0603	-0.0603	-0.0603	-0.0603	-0.0603
0.525	0.0000	-0.0214	-0.0016	-0.0637	-0.0637	-0.0637	-0.0637	-0.0637	-0.0637	-0.0637
0.550	-0.0679	-0.0308	-0.0037	-0.0597	-0.0597	-0.0597	-0.0597	-0.0597	-0.0597	-0.0597
0.575	0.0000	-0.0317	0.0039	-0.0621	-0.0621	-0.0621	-0.0621	-0.0621	-0.0621	-0.0621
0.600	-0.0768	-0.0356	-0.0131	-0.0637	-0.0637	-0.0637	-0.0637	-0.0637	-0.0637	-0.0637
0.625	0.0000	0.0000	-0.0115	-0.0635	-0.0635	-0.0635	-0.0635	-0.0635	-0.0635	-0.0635
0.650	-0.0803	-0.0351	-0.0153	-0.0642	-0.0642	-0.0642	-0.0642	-0.0642	-0.0642	-0.0642
0.675	0.0000	-0.0524	-0.0211	-0.0671	-0.0671	-0.0671	-0.0671	-0.0671	-0.0671	-0.0671
0.700	-0.0805	-0.0620	-0.0254	-0.0679	-0.0679	-0.0679	-0.0679	-0.0679	-0.0679	-0.0679
0.725	0.0000	-0.0703	0.0000	-0.0701	-0.0701	-0.0701	-0.0701	-0.0701	-0.0701	-0.0701
0.750	-0.0748	-0.0799	0.0000	-0.0725	-0.0725	-0.0725	-0.0725	-0.0725	-0.0725	-0.0725
0.775	0.0000	-0.0846	-0.0511	-0.0792	-0.0792	-0.0792	-0.0792	-0.0792	-0.0792	-0.0792
0.800	-0.0601	-0.0904	-0.0658	-0.0893	-0.0893	-0.0893	-0.0893	-0.0893	-0.0893	-0.0893
0.825	0.0000	-0.0923	-0.0800	-0.0889	-0.0889	-0.0889	-0.0889	-0.0889	-0.0889	-0.0889
0.850	-0.0389	-0.0931	-0.0933	-0.1157	-0.1157	-0.1157	-0.1157	-0.1157	-0.1157	-0.1157
0.875	0.0000	-0.0881	-0.1018	-0.1291	-0.1291	-0.1291	-0.1291	-0.1291	-0.1291	-0.1291
0.900	-0.0142	-0.0823	-0.1071	-0.1465	-0.1465	-0.1465	-0.1465	-0.1465	-0.1465	-0.1465
0.925	0.0000	-0.0634	-0.1008	-0.1504	-0.1504	-0.1504	-0.1504	-0.1504	-0.1504	-0.1504
0.950	0.0293	-0.0318	-0.0763	-0.1333	-0.1333	-0.1333	-0.1333	-0.1333	-0.1333	-0.1333
0.975	0.0000	0.0181	-0.0277	-0.0832	-0.0832	-0.0832	-0.0832	-0.0832	-0.0832	-0.0832
1.000	0.1946	0.1896	0.1931	0.1477	0.1477	0.1477	0.1477	0.1477	0.1477	0.1477
	$C_{p,l}$	$C_{p,l}$	$C_{p,l}$	$C_{p,l}$	$C_{p,l}$	$C_{p,l}$	$C_{p,l}$	$C_{p,l}$	$C_{p,l}$	$C_{p,l}$
-0.200	-0.0046	0.0138	0.0592	0.0592	0.0592	0.0592	0.0592	0.0592	0.0592	0.0592
-0.400	-0.0290	0.0114	0.0248	0.0248	0.0248	0.0248	0.0248	0.0248	0.0248	0.0248
-0.600	-0.0428	-0.0041	0.0050	0.0050	0.0050	0.0050	0.0050	0.0050	0.0050	0.0050
-0.700	-0.0397	-0.0346	-0.0087	-0.0547	-0.0547	-0.0547	-0.0547	-0.0547	-0.0547	-0.0547
-0.800	-0.0200	0.0000	-0.0432	-0.0641	-0.0641	-0.0641	-0.0641	-0.0641	-0.0641	-0.0641
-0.850	0.0000	-0.0472	-0.0625	-0.0868	-0.0868	-0.0868	-0.0868	-0.0868	-0.0868	-0.0868
-0.900	0.0000	-0.0275	-0.0625	-0.1072	-0.1072	-0.1072	-0.1072	-0.1072	-0.1072	-0.1072
-0.950	0.0869	0.0232	-0.0140	-0.0805	-0.0805	-0.0805	-0.0805	-0.0805	-0.0805	-0.0805
-0.975	0.0000	0.0888	0.0350	-0.0110	-0.2565	-0.2565	-0.2565	-0.2565	-0.2565	-0.2565
-1.000	0.1903	0.1824	0.1479	0.1596	0.1596	0.1596	0.1596	0.1596	0.1596	0.1596

Medium Radius L.E.
 Run No. = 29 , Point No. = 578
 $C_N = 0.024$, $C_m = -0.0092$
 $\alpha = 0.8^\circ$, $M_\infty = 0.399$
 $R_{mac} = 72.9 \times 10^6$

Leading Edge Pressures

● starboard
 ○ port

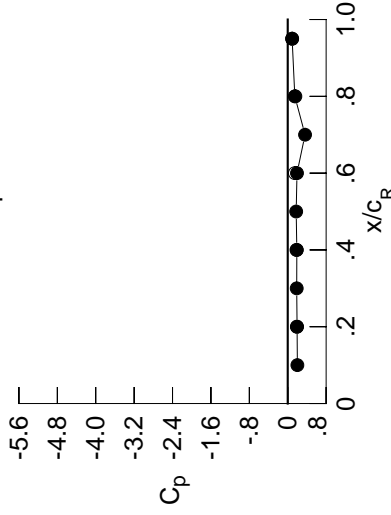

x/c_R	starb'd C_p	port C_p
0.10	0.2009	0.1903
0.20	0.1946	0.1824
0.30	0.1870	0.1761
0.40	0.1896	0.1479
0.50	0.1761	0.3612
0.60	0.1931	0.1477
0.70	0.3612	0.1596
0.80	0.1477	0.0931
0.90	0.0931	0.0916
0.95	0.0916	0.0931

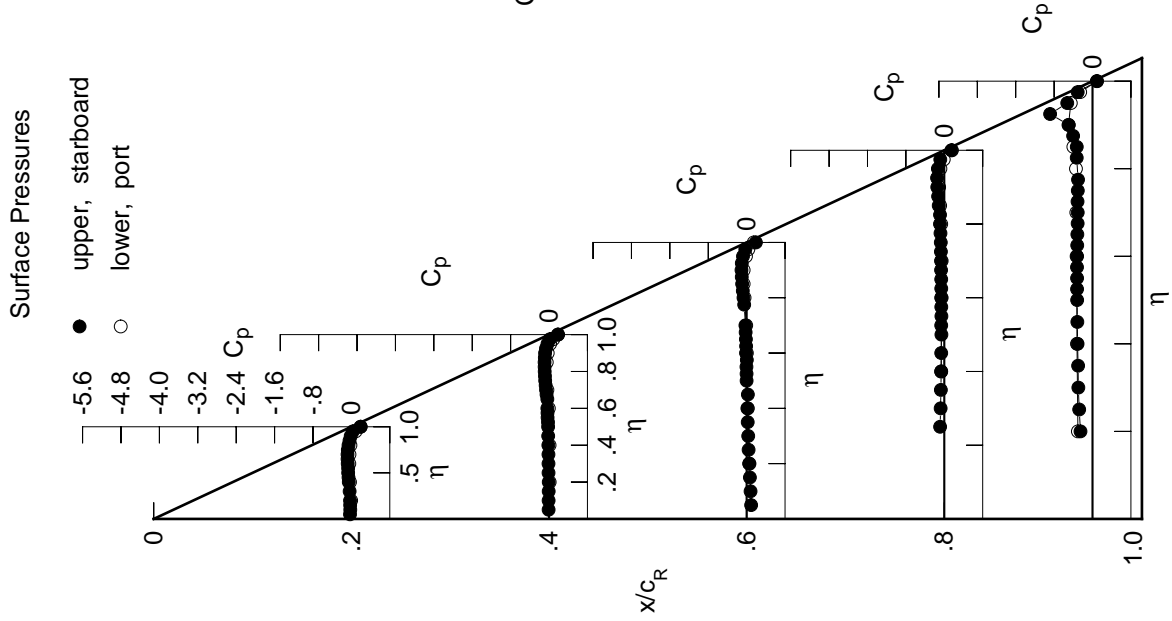

Table C3. Continued.

η	x/c_R .2	x/c_R .4	x/c_R .6	x/c_R .8	x/c_R .95
	$C_{p,u}$	$C_{p,u}$	$C_{p,u}$	$C_{p,u}$	$C_{p,u}$
0.050	-0.0446	-0.0221	0.0841	*****	*****
0.100	-0.0402	-0.0225	0.0722	*****	*****
0.150	-0.0434	-0.0207	0.0590	*****	*****
0.200	-0.0474	-0.0198	0.0451	*****	-0.2480
0.250	*****	-0.0245	0.0302	-0.0929	-0.2725
0.300	-0.0557	-0.0254	0.0230	-0.0829	-0.2898
0.350	*****	-0.0281	0.0110	-0.0764	-0.2915
0.400	-0.0752	-0.0301	0.0031	-0.0707	-0.3044
0.450	-0.0823	-0.0345	0.0119	-0.0693	-0.3087
0.500	-0.0914	-0.0367	-0.0119	-0.0683	-0.3132
0.525	*****	-0.0397	-0.0154	-0.0711	-0.3137
0.550	-0.0940	-0.0507	-0.0173	-0.0685	-0.3144
0.575	*****	-0.0505	-0.0111	-0.0710	-0.3167
0.600	-0.1054	-0.0571	-0.0279	-0.0733	-0.3149
0.625	*****	*****	-0.0266	-0.0730	-0.3128
0.650	-0.1118	-0.0577	-0.0328	-0.0758	-0.3101
0.675	*****	-0.0770	-0.0392	-0.0793	-0.3032
0.700	-0.1152	-0.0880	-0.0458	-0.0810	-0.3010
0.725	*****	-0.0986	*****	-0.0836	-0.3042
0.750	-0.1116	-0.1115	*****	-0.0879	-0.2996
0.775	*****	-0.1189	-0.0764	-0.0971	-0.2940
0.800	-0.1011	-0.1288	-0.0940	-0.1102	*****
0.825	*****	-0.1332	-0.1126	-0.1105	-0.3223
0.850	-0.0837	-0.1391	-0.1303	-0.1425	-0.3233
0.875	*****	-0.1383	-0.1457	-0.1626	-0.4049
0.900	-0.0637	-0.1369	-0.1574	-0.1867	-0.5045
0.925	*****	-0.1231	-0.1594	-0.1998	-0.9197
0.950	-0.0267	-0.0956	-0.1449	-0.1944	-0.5682
0.975	*****	-0.0599	-0.1080	-0.1574	-0.3609
1.000	0.1610	0.1316	0.1200	0.0786	0.0575
	$C_{p,l}$	$C_{p,l}$	$C_{p,l}$	$C_{p,l}$	$C_{p,l}$
-0.200	0.0155	0.0291	0.0699	*****	-0.3073
-0.400	-0.0047	0.0287	0.0383	-0.0557	-0.3291
-0.600	-0.0134	0.0178	0.0217	-0.0446	-0.3361
-0.700	-0.0058	-0.0064	0.0116	-0.0408	-0.3428
-0.800	0.0190	*****	-0.0139	-0.0446	-0.3508
-0.850	*****	-0.0056	-0.0257	-0.0595	-0.3994
-0.900	*****	0.0199	-0.0173	-0.0682	-0.4891
-0.950	0.1309	0.0758	0.0397	-0.0291	-0.4109
-0.975	*****	0.1399	0.0904	0.0459	-0.2065
-1.000	0.1572	0.1335	0.0924	0.1023	0.0638

Medium Radius L.E.
 Run No. = 29 , Point No. = 579
 $C_N = 0.060$, $C_m = -0.0129$
 $\alpha = 1.8^\circ$, $M_\infty = 0.399$
 $R_{mac} = 72.7 \times 10^6$

Leading Edge Pressures

● starboard
 ○ port

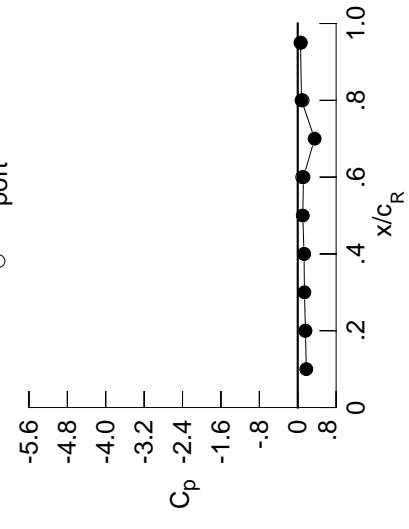

x/c_R	starb'd C_p	port C_p
0.10	0.1781	*****
0.20	0.1610	0.1572
0.30	0.1395	*****
0.40	0.1316	0.1335
0.50	0.1051	*****
0.60	0.1200	0.0924
0.70	0.3522	*****
0.80	0.0786	0.1023
0.90	*****	*****
0.95	0.0575	0.0638

Surface Pressures

● upper, starboard
 ○ lower, port

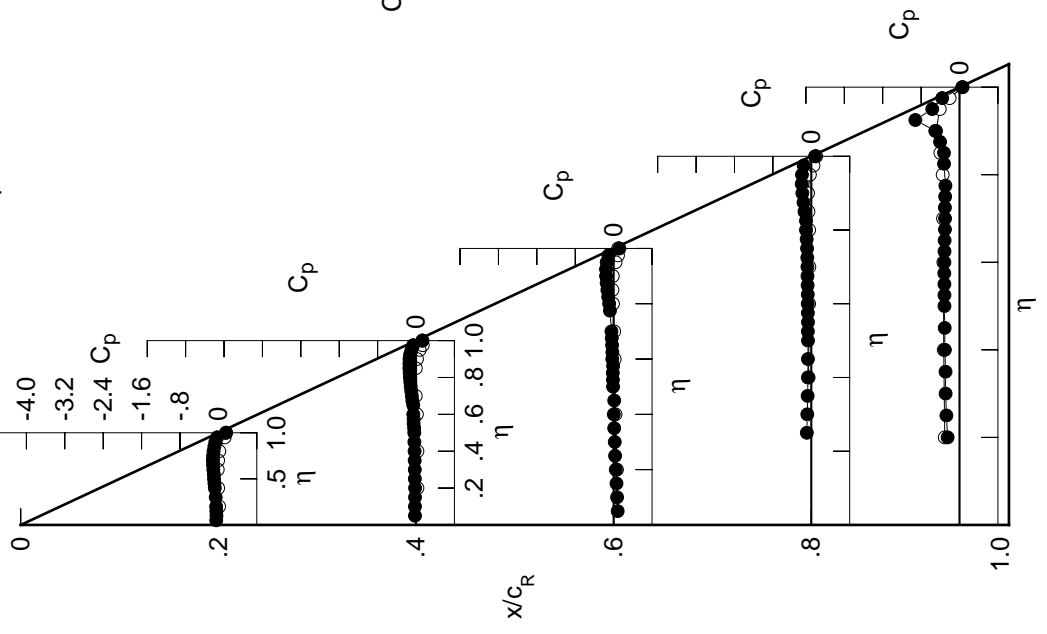
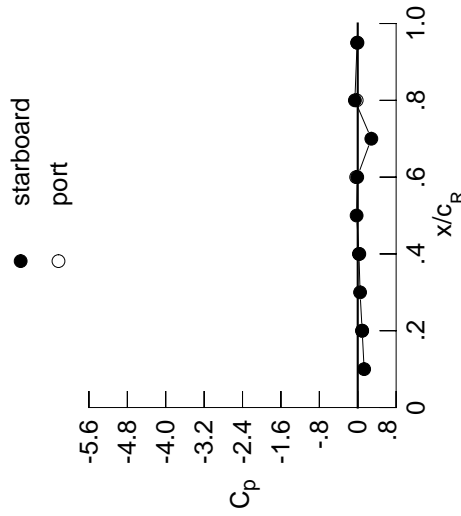

Table C3. Continued.

η	$x/c_R = .2$		$x/c_R = .4$		$x/c_R = .6$		$x/c_R = .8$		$x/c_R = .95$	
	$C_{p,u}$	$C_{p,l}$	$C_{p,u}$	$C_{p,l}$	$C_{p,u}$	$C_{p,l}$	$C_{p,u}$	$C_{p,l}$	$C_{p,u}$	$C_{p,l}$
0.050	-0.0612	-0.0362	0.0750	0.0750	0.0750	0.0750	0.0750	0.0750	0.0750	0.0750
0.100	-0.0566	-0.0360	0.0648	0.0648	0.0648	0.0648	0.0648	0.0648	0.0648	0.0648
0.150	-0.0614	-0.0359	0.0483	0.0483	0.0483	0.0483	0.0483	0.0483	0.0483	0.0483
0.200	-0.0636	-0.0343	0.0361	0.0361	0.0361	0.0361	0.0361	0.0361	0.0361	0.0361
0.250	0.0000	-0.0380	0.0209	-0.0973	0.0209	-0.0973	0.0209	-0.0973	0.0209	-0.2646
0.300	-0.0750	-0.0396	0.0134	-0.0888	0.0134	-0.0888	0.0134	-0.0888	0.0134	-0.2812
0.350	0.0000	-0.0425	0.0012	-0.0813	0.0012	-0.0813	0.0012	-0.0813	0.0012	-0.2844
0.400	-0.0963	-0.0456	-0.0077	-0.0773	-0.0077	-0.0773	-0.0077	-0.0773	-0.0077	-0.2964
0.450	-0.1049	-0.0504	0.0021	-0.0762	0.0021	-0.0762	0.0021	-0.0762	0.0021	-0.3018
0.500	-0.1161	-0.0539	-0.0266	-0.0750	-0.0266	-0.0750	-0.0266	-0.0750	-0.0266	-0.3054
0.525	0.0000	-0.0580	-0.0278	-0.0788	-0.0278	-0.0788	-0.0278	-0.0788	-0.0278	-0.3080
0.550	-0.1215	-0.0675	-0.0325	-0.0760	-0.0325	-0.0760	-0.0325	-0.0760	-0.0325	-0.3061
0.575	0.0000	-0.0720	-0.0246	-0.0805	-0.0246	-0.0805	-0.0246	-0.0805	-0.0246	-0.3100
0.600	-0.1350	-0.0758	-0.0433	-0.0821	-0.0433	-0.0821	-0.0433	-0.0821	-0.0433	-0.3086
0.625	0.0000	0.0000	-0.0426	-0.0823	-0.0426	-0.0823	-0.0426	-0.0823	-0.0426	-0.3061
0.650	-0.1436	-0.0828	-0.0482	-0.0859	-0.0482	-0.0859	-0.0482	-0.0859	-0.0482	-0.3033
0.675	0.0000	-0.1010	-0.0580	-0.0896	-0.0580	-0.0896	-0.0580	-0.0896	-0.0580	-0.2963
0.700	-0.1508	-0.1158	-0.0640	-0.0927	-0.0640	-0.0927	-0.0640	-0.0927	-0.0640	-0.2958
0.725	0.0000	-0.1286	0.0000	-0.0980	0.0000	-0.0980	0.0000	-0.0980	0.0000	-0.2970
0.750	-0.1509	-0.1428	0.0000	-0.1022	0.0000	-0.1022	0.0000	-0.1022	0.0000	-0.2919
0.775	0.0000	-0.1545	-0.1033	-0.1143	-0.1033	-0.1143	-0.1033	-0.1143	-0.1033	-0.2841
0.800	-0.1448	-0.1677	-0.1233	-0.1277	-0.1233	-0.1277	-0.1233	-0.1277	-0.1233	-0.2844
0.825	0.0000	-0.1763	-0.1458	-0.1313	-0.1458	-0.1313	-0.1458	-0.1313	-0.1458	-0.3140
0.850	-0.1314	-0.1850	-0.1699	-0.1691	-0.1699	-0.1691	-0.1699	-0.1691	-0.1699	-0.3198
0.875	0.0000	-0.1911	-0.1897	-0.1964	-0.1897	-0.1964	-0.1897	-0.1964	-0.1897	-0.4073
0.900	-0.1186	-0.1942	-0.2099	-0.2294	-0.2099	-0.2294	-0.2099	-0.2294	-0.2099	-0.5136
0.925	0.0000	-0.1877	-0.2188	-0.2517	-0.2188	-0.2517	-0.2188	-0.2517	-0.2188	-0.9475
0.950	-0.0920	-0.1692	-0.2170	-0.2593	-0.2170	-0.2593	-0.2170	-0.2593	-0.2170	-0.5965
0.975	0.0000	-0.1527	-0.1986	-0.2434	-0.1986	-0.2434	-0.1986	-0.2434	-0.1986	-0.3998
1.000	0.0924	0.0257	-0.0107	-0.0694	-0.0107	-0.0694	-0.0107	-0.0694	-0.0107	-0.0132
-0.200	$C_{p,l}$	$C_{p,l}$	$C_{p,l}$	$C_{p,l}$	$C_{p,l}$	$C_{p,l}$	$C_{p,l}$	$C_{p,l}$	$C_{p,l}$	$C_{p,l}$
-0.400	0.0359	0.0464	0.0835	0.0835	0.0835	0.0835	0.0835	0.0835	0.0835	-0.3131
-0.600	0.0175	0.0476	0.0508	0.0508	0.0508	0.0508	0.0508	0.0508	0.0508	-0.3340
-0.700	0.0142	0.0387	0.0380	0.0380	0.0380	0.0380	0.0380	0.0380	0.0380	-0.3425
-0.800	0.0256	0.0184	0.0312	0.0279	0.0312	0.0279	0.0312	0.0279	0.0312	-0.3477
-0.850	0.0542	0.0000	0.0107	-0.0251	0.0107	-0.0251	0.0107	-0.0251	0.0107	-0.3561
-0.900	0.0000	0.0314	0.0065	-0.0353	0.0065	-0.0353	0.0065	-0.0353	0.0065	-0.4030
-0.950	0.0000	0.0611	0.0209	-0.0348	0.0209	-0.0348	0.0209	-0.0348	0.0209	-0.4805
-0.975	0.1637	0.1169	0.0826	0.0149	0.0826	0.0149	0.0826	0.0149	0.0826	-0.3729
-1.000	0.0000	0.1755	0.1314	0.0893	0.1314	0.0893	0.1314	0.0893	0.1314	-0.1619
	0.0894	0.0328	-0.0331	-0.0213	-0.0331	-0.0213	-0.0331	-0.0213	-0.0331	-0.0059

Medium Radius L.E.
 Run No. = 29 , Point No. = 580
 $C_N = 0.091$, $C_m = -0.0151$
 $\alpha = 2.8^\circ$, $M_\infty = 0.399$
 $R_{mac} = 72.9 \times 10^6$

Leading Edge Pressures



x/c_R	starb'd C_p	port C_p
0.10	0.1335	0.0894
0.20	0.0924	0.0894
0.30	0.0485	0.0894
0.40	0.0257	0.0328
0.50	-0.0232	0.0328
0.60	-0.0107	-0.0331
0.70	0.2830	0.0328
0.80	-0.0594	-0.0213
0.90	0.0000	0.0000
0.95	-0.0132	-0.0059

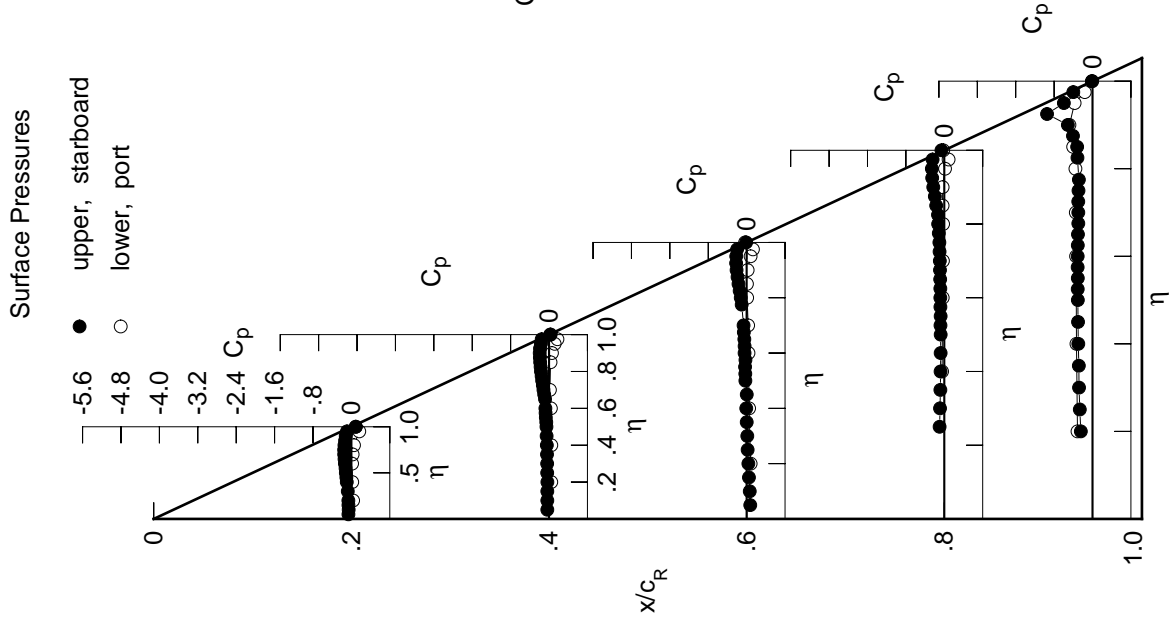
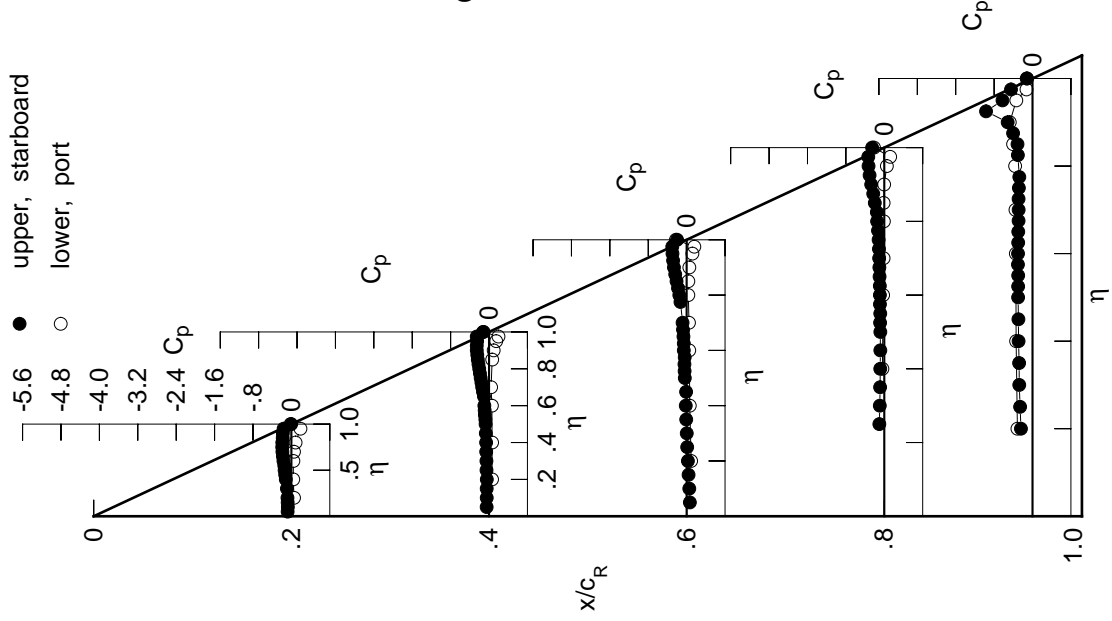

Table C3. Continued.

η	x/c_R .2	x/c_R .4	x/c_R .6	x/c_R .8	x/c_R .95
	$C_{p,u}$	$C_{p,u}$	$C_{p,u}$	$C_{p,u}$	$C_{p,u}$
0.050	-0.0785	-0.0494	0.0674	*****	*****
0.100	-0.0735	-0.0480	0.0553	*****	*****
0.150	-0.0778	-0.0488	0.0402	*****	*****
0.200	-0.0817	-0.0468	0.0264	*****	-0.2410
0.250	*****	-0.0530	0.0112	-0.1033	-0.2585
0.300	-0.0931	-0.0543	0.0025	-0.0937	-0.2759
0.350	*****	-0.0591	-0.0088	-0.0875	-0.2790
0.400	-0.1169	-0.0605	-0.0182	-0.0840	-0.2905
0.450	-0.1290	-0.0674	-0.0113	-0.0820	-0.2940
0.500	-0.1419	-0.0718	-0.0387	-0.0824	-0.3000
0.525	*****	-0.0764	-0.0426	-0.0870	-0.2989
0.550	-0.1481	-0.0870	-0.0458	-0.0840	-0.2985
0.575	*****	-0.0911	-0.0402	-0.0905	-0.3034
0.600	-0.1654	-0.0977	-0.0590	-0.0916	-0.3019
0.625	*****	*****	-0.0592	-0.0930	-0.2981
0.650	-0.1766	-0.1054	-0.0663	-0.0982	-0.2968
0.675	*****	-0.1260	-0.0759	-0.1025	-0.2903
0.700	-0.1872	-0.1422	-0.0851	-0.1072	-0.2889
0.725	*****	-0.1585	*****	-0.1115	-0.2906
0.750	-0.1913	-0.1742	*****	-0.1182	-0.2838
0.775	*****	-0.1894	-0.1284	-0.1315	-0.2754
0.800	-0.1892	-0.2040	-0.1532	-0.1493	*****
0.825	*****	-0.2200	-0.1798	-0.1549	-0.3048
0.850	-0.1811	-0.2345	-0.2104	-0.1977	-0.3125
0.875	*****	-0.2449	-0.2378	-0.2308	-0.4046
0.900	-0.1780	-0.2550	-0.2650	-0.2728	-0.5175
0.925	*****	-0.2562	-0.2825	-0.3064	-0.9680
0.950	-0.1626	-0.2484	-0.2951	-0.3277	-0.6254
0.975	*****	-0.2556	-0.2993	-0.3340	-0.4478
1.000	-0.0050	-0.1242	-0.1995	-0.2538	-0.1209
	$C_{p,l}$	$C_{p,l}$	$C_{p,l}$	$C_{p,l}$	$C_{p,l}$
-0.200	0.0551	0.0630	0.0940	*****	-0.3145
-0.400	0.0390	0.0642	0.0653	-0.0394	-0.3414
-0.600	0.0415	0.0597	0.0547	-0.0237	-0.3475
-0.700	0.0544	0.0430	0.0486	-0.0145	-0.3556
-0.800	0.0869	*****	0.0353	-0.0081	-0.3624
-0.850	*****	0.0653	0.0354	-0.0133	-0.4046
-0.900	*****	0.0971	0.0562	-0.0034	-0.4734
-0.950	0.1890	0.1499	0.1198	0.0538	-0.3373
-0.975	*****	0.1968	0.1600	0.1227	-0.1255
-1.000	-0.0162	-0.1138	-0.2240	-0.2135	-0.1131

Surface Pressures



Medium Radius L.E.
 Run No. = 29, Point No. = 581
 $C_N = 0.123$, $C_m = -0.0176$
 $\alpha = 3.9^\circ$, $M_\infty = 0.399$
 $R_{mac} = 72.9 \times 10^6$

Leading Edge Pressures

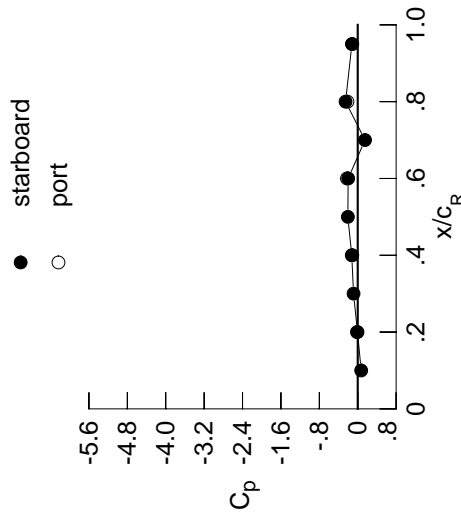

x/c_R	starb'd C_p	port C_p
0.10	0.0721	*****
0.20	-0.0050	-0.0162
0.30	-0.0876	*****
0.40	-0.1242	-0.1138
0.50	-0.2059	*****
0.60	-0.1995	-0.2240
0.70	0.1522	*****
0.80	-0.2538	-0.2135
0.90	*****	*****
0.95	-0.1209	-0.1131

Table C3. Continued.

η	$x/c_R = .2$		$x/c_R = .4$		$x/c_R = .6$		$x/c_R = .8$		$x/c_R = .95$	
	$C_{p,u}$	$C_{p,l}$	$C_{p,u}$	$C_{p,l}$	$C_{p,u}$	$C_{p,l}$	$C_{p,u}$	$C_{p,l}$	$C_{p,u}$	$C_{p,l}$
0.050	-0.0954	-0.0634	0.0589	*****	*****	*****	*****	*****	*****	*****
0.100	-0.0917	-0.0626	0.0462	*****	*****	*****	*****	*****	*****	*****
0.150	-0.0954	-0.0622	0.0314	*****	*****	*****	*****	*****	*****	*****
0.200	-0.1001	-0.0607	0.0165	*****	*****	*****	*****	*****	*****	*****
0.250	*****	-0.0670	0.0018	-0.1084	-0.1084	-0.1084	-0.1084	-0.2544	-0.2544	-0.2544
0.300	-0.1128	-0.0699	-0.0072	-0.1000	-0.1000	-0.1000	-0.1000	-0.2672	-0.2672	-0.2672
0.350	*****	-0.0741	-0.0202	-0.0938	-0.0938	-0.0938	-0.0938	-0.2697	-0.2697	-0.2697
0.400	-0.1382	-0.0767	-0.0298	-0.0888	-0.0888	-0.0888	-0.0888	-0.2818	-0.2818	-0.2818
0.450	-0.1526	-0.0847	-0.0230	-0.0909	-0.0909	-0.0909	-0.0909	-0.2855	-0.2855	-0.2855
0.500	-0.1673	-0.0897	-0.0513	-0.0898	-0.0898	-0.0898	-0.0898	-0.2914	-0.2914	-0.2914
0.525	*****	-0.0964	-0.0563	-0.0952	-0.0952	-0.0952	-0.0952	-0.2903	-0.2903	-0.2903
0.550	-0.1779	-0.1075	-0.0605	-0.0923	-0.0923	-0.0923	-0.0923	-0.2900	-0.2900	-0.2900
0.575	*****	-0.1126	-0.0556	-0.0991	-0.0991	-0.0991	-0.0991	-0.2948	-0.2948	-0.2948
0.600	-0.1973	-0.1210	-0.0742	-0.1012	-0.1012	-0.1012	-0.1012	-0.2930	-0.2930	-0.2930
0.625	*****	*****	-0.0767	-0.1035	-0.1035	-0.1035	-0.1035	-0.2906	-0.2906	-0.2906
0.650	-0.2119	-0.1309	-0.0840	-0.1083	-0.1083	-0.1083	-0.1083	-0.2875	-0.2875	-0.2875
0.675	*****	-0.1536	-0.0974	-0.1147	-0.1147	-0.1147	-0.1147	-0.2822	-0.2822	-0.2822
0.700	-0.2269	-0.1719	-0.1066	-0.1201	-0.1201	-0.1201	-0.1201	-0.2813	-0.2813	-0.2813
0.725	*****	-0.1908	*****	-0.1280	-0.1280	-0.1280	-0.1280	-0.2808	-0.2808	-0.2808
0.750	-0.2352	-0.2106	*****	-0.1368	-0.1368	-0.1368	-0.1368	-0.2702	-0.2702	-0.2702
0.775	*****	-0.2299	-0.1570	-0.1518	-0.1518	-0.1518	-0.1518	-0.2622	-0.2622	-0.2622
0.800	-0.2396	-0.2507	-0.1850	-0.1710	-0.1710	-0.1710	-0.1710	-0.2622	-0.2622	-0.2622
0.825	*****	-0.2700	-0.2177	-0.1791	-0.1791	-0.1791	-0.1791	-0.2906	-0.2906	-0.2906
0.850	-0.2382	-0.2879	-0.2538	-0.2284	-0.2284	-0.2284	-0.2284	-0.3051	-0.3051	-0.3051
0.875	*****	-0.3066	-0.2892	-0.2693	-0.2693	-0.2693	-0.2693	-0.4001	-0.4001	-0.4001
0.900	-0.2450	-0.3258	-0.3269	-0.3209	-0.3209	-0.3209	-0.3209	-0.5205	-0.5205	-0.5205
0.925	*****	-0.3371	-0.3602	-0.3670	-0.3670	-0.3670	-0.3670	-0.9899	-0.9899	-0.9899
0.950	-0.2465	-0.3436	-0.3865	-0.4072	-0.4072	-0.4072	-0.4072	-0.6607	-0.6607	-0.6607
0.975	*****	-0.3787	-0.4237	-0.4428	-0.4428	-0.4428	-0.4428	-0.5105	-0.5105	-0.5105
1.000	-0.1458	-0.3443	-0.4674	-0.5323	-0.5323	-0.5323	-0.5323	-0.2796	-0.2796	-0.2796
-0.200	$C_{p,l}$	0.0757	0.0796	0.1062	*****	*****	*****	-0.3179	-0.3179	-0.3179
-0.400	$C_{p,l}$	0.0622	0.0823	0.0790	-0.0283	-0.3457	-0.3457	-0.3457	-0.3457	-0.3457
-0.600	$C_{p,l}$	0.0690	0.0798	0.0710	-0.0126	-0.3546	-0.3546	-0.3546	-0.3546	-0.3546
-0.700	$C_{p,l}$	0.0852	0.0682	0.0675	-0.0001	-0.3621	-0.3621	-0.3621	-0.3621	-0.3621
-0.800	$C_{p,l}$	0.1179	*****	0.0608	0.0105	-0.3663	-0.3663	-0.3663	-0.3663	-0.3663
-0.850	$C_{p,l}$	*****	0.0988	0.0656	0.0099	-0.4061	-0.4061	-0.4061	-0.4061	-0.4061
-0.900	$C_{p,l}$	*****	0.1323	0.0913	0.0255	-0.4635	-0.4635	-0.4635	-0.4635	-0.4635
-0.950	$C_{p,l}$	0.2086	0.1771	0.1484	0.0854	-0.3036	-0.3036	-0.3036	-0.3036	-0.3036
-0.975	$C_{p,l}$	*****	0.2067	0.1775	0.1455	-0.0925	-0.0925	-0.0925	-0.0925	-0.0925
-1.000	$C_{p,l}$	-0.1667	-0.3318	-0.5095	-0.4691	-0.2582	-0.2582	-0.2582	-0.2582	-0.2582

Medium Radius L.E.

Run No. = 29 , Point No. = 582

$C_N = 0.160$, $C_m = -0.0237$

$\alpha = 4.9^\circ$, $M_\infty = 0.399$

$R_{mac} = 72.6 \times 10^6$

Leading Edge Pressures

● starboard
○ port

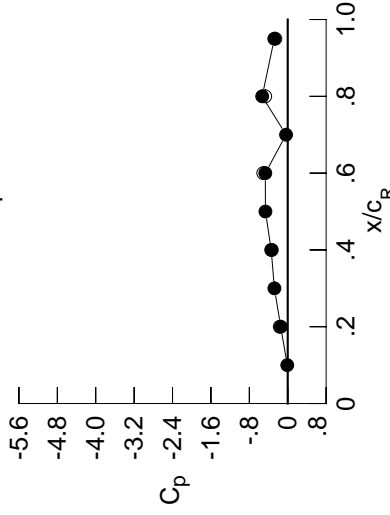

x/c_R	starb'd C_p	port C_p
0.10	-0.0097	*****
0.20	-0.1458	-0.1667
0.30	-0.2778	*****
0.40	-0.3443	-0.3318
0.50	-0.4647	*****
0.60	-0.4674	-0.5095
0.70	-0.0348	*****
0.80	-0.5323	-0.4691
0.90	*****	*****
0.95	-0.2796	-0.2582

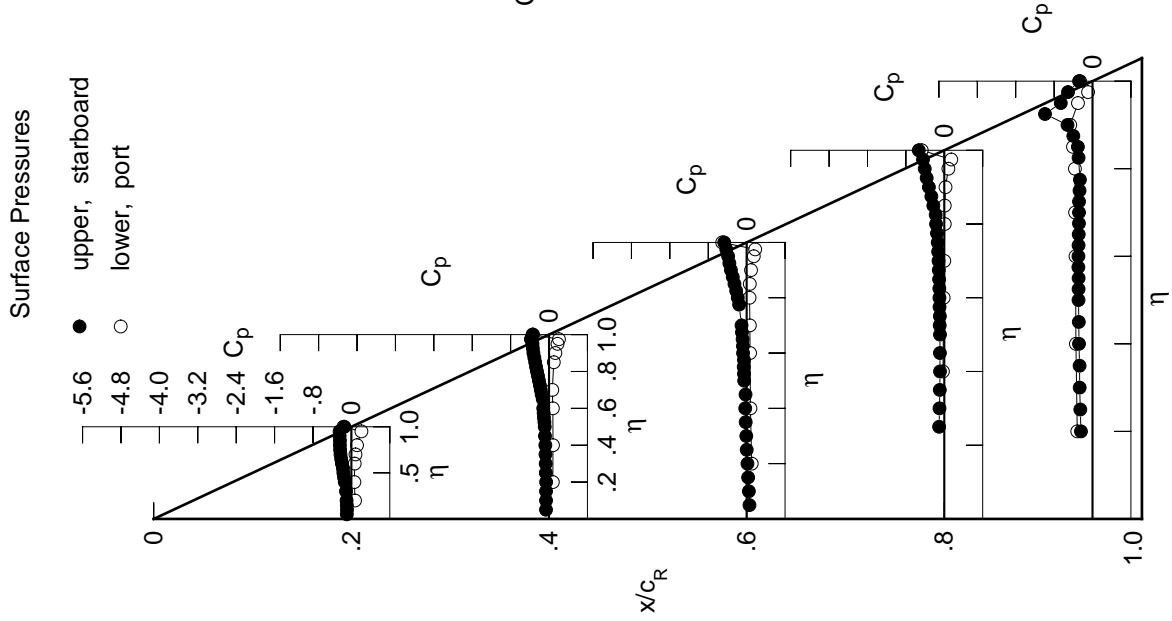
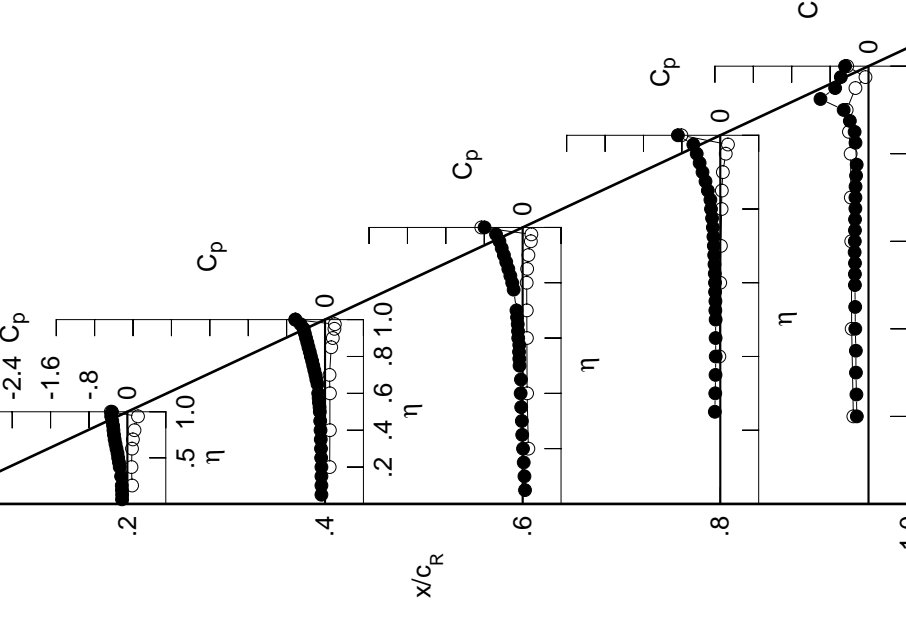
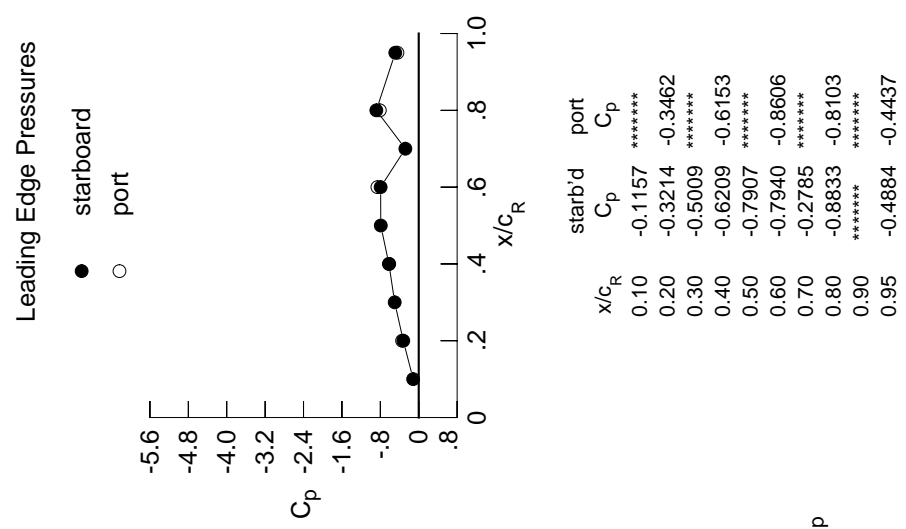

Table C3. Continued.

η	$x/c_R = .2$		$x/c_R = .4$		$x/c_R = .6$		$x/c_R = .8$		$x/c_R = .95$	
	$C_{p,u}$	$C_{p,u}$	$C_{p,u}$	$C_{p,u}$	$C_{p,u}$	$C_{p,u}$	$C_{p,u}$	$C_{p,u}$	$C_{p,u}$	$C_{p,u}$
0.050	-0.1117	-0.0752	0.0497	*****	*****	*****	*****	*****	*****	
0.100	-0.1095	-0.0751	0.0380	*****	*****	*****	*****	*****	*****	
0.150	-0.1135	-0.0753	0.0220	*****	*****	*****	*****	*****	*****	
0.200	-0.1171	-0.0749	0.0078	*****	*****	*****	*****	*****	-0.2430	
0.250	*****	-0.0810	-0.0087	-0.1137	-0.2516	*****	*****	*****	*****	
0.300	-0.1316	-0.0842	-0.0167	-0.1051	-0.2617	*****	*****	*****	*****	
0.350	*****	-0.0888	-0.0303	-0.0990	-0.2631	*****	*****	*****	*****	
0.400	-0.1602	-0.0937	-0.0413	-0.0949	-0.2753	*****	*****	*****	*****	
0.450	-0.1750	-0.1004	-0.0355	-0.0973	-0.2772	*****	*****	*****	*****	
0.500	-0.1923	-0.1089	-0.0647	-0.0966	-0.2829	*****	*****	*****	*****	
0.525	*****	-0.1145	-0.0694	-0.1031	-0.2834	*****	*****	*****	*****	
0.550	-0.2054	-0.1274	-0.0754	-0.1015	-0.2814	*****	*****	*****	*****	
0.575	*****	-0.1334	-0.0706	-0.1086	-0.2885	*****	*****	*****	*****	
0.600	-0.2276	-0.1423	-0.0919	-0.1107	-0.2860	*****	*****	*****	*****	
0.625	*****	*****	-0.0962	-0.1140	-0.2823	*****	*****	*****	*****	
0.650	-0.2469	-0.1566	-0.1022	-0.1210	-0.2806	*****	*****	*****	*****	
0.675	*****	-0.1808	-0.1163	-0.1269	-0.2739	*****	*****	*****	*****	
0.700	-0.2654	-0.2000	-0.1285	-0.1346	-0.2725	*****	*****	*****	*****	
0.725	*****	-0.2232	*****	-0.1436	-0.2705	*****	*****	*****	*****	
0.750	-0.2793	-0.2456	*****	-0.1547	-0.2592	*****	*****	*****	*****	
0.775	*****	-0.2682	-0.1870	-0.1713	-0.2466	*****	*****	*****	*****	
0.800	-0.2905	-0.2951	-0.2178	-0.1932	*****	*****	*****	*****	*****	
0.825	*****	-0.3181	-0.2558	-0.2056	-0.2710	*****	*****	*****	*****	
0.850	-0.2983	-0.3445	-0.2985	-0.2590	-0.2897	*****	*****	*****	*****	
0.875	*****	-0.3691	-0.3419	-0.3077	-0.3891	*****	*****	*****	*****	
0.900	-0.3154	-0.3964	-0.3904	-0.3706	-0.5176	*****	*****	*****	*****	
0.925	*****	-0.4207	-0.4359	-0.4307	-1.0008	*****	*****	*****	*****	
0.950	-0.3377	-0.4441	-0.4840	-0.4914	-0.6955	*****	*****	*****	*****	
0.975	*****	-0.5093	-0.5547	-0.5620	-0.5767	*****	*****	*****	*****	
1.000	-0.3214	-0.6209	-0.7940	-0.8833	-0.4884	*****	*****	*****	*****	
-0.200	$C_{p,l}$	$C_{p,l}$	$C_{p,l}$	$C_{p,l}$	$C_{p,l}$	$C_{p,l}$	$C_{p,l}$	$C_{p,l}$	$C_{p,l}$	
-0.400	0.0972	0.0966	0.1195	*****	*****	-0.3158	*****	*****	*****	
-0.600	0.0854	0.1010	0.0930	-0.0189	-0.3510	*****	*****	*****	*****	
-0.700	0.0961	0.1014	0.0887	-0.0014	-0.3602	*****	*****	*****	*****	
-0.800	0.1145	0.0933	0.0867	0.0126	-0.3688	*****	*****	*****	*****	
-0.850	0.1482	*****	0.0839	0.0276	-0.3717	*****	*****	*****	*****	
-0.900	*****	0.1292	0.0934	0.0322	-0.4079	*****	*****	*****	*****	
-0.950	0.2206	0.1960	0.1714	0.1132	-0.2718	*****	*****	*****	*****	
-0.975	*****	0.2038	0.1820	0.1599	-0.0634	*****	*****	*****	*****	
-1.000	-0.3462	-0.6153	-0.8606	-0.8103	-0.4437	*****	*****	*****	*****	

Medium Radius L.E.
 Run No. = 29 , Point No. = 583
 $C_N = 0.195$, $C_m = -0.0282$
 $\alpha = 6.0^\circ$, $M_\infty = 0.399$
 $R_{mac} = 72.7 \times 10^6$



x/c_R	starb'd C_p	port C_p
0.10	-0.1157	*****
0.20	-0.3214	-0.3462
0.30	-0.5009	*****
0.40	-0.6209	-0.6153
0.50	-0.7907	*****
0.60	-0.7940	-0.8606
0.70	-0.2785	*****
0.80	-0.8833	-0.8103
0.90	*****	*****
0.95	-0.4884	-0.4437

Table C3. Continued.

η	$x/c_R = .2$		$x/c_R = .4$		$x/c_R = .6$		$x/c_R = .8$		$x/c_R = .95$	
	$C_{p,u}$	$C_{p,u}$	$C_{p,u}$	$C_{p,u}$	$C_{p,u}$	$C_{p,u}$	$C_{p,u}$	$C_{p,u}$	$C_{p,u}$	$C_{p,u}$
0.050	-0.1233	-0.0846	0.0440	*****	*****	*****	*****	*****	*****	*****
0.100	-0.1226	-0.0848	0.0313	*****	*****	*****	*****	*****	*****	*****
0.150	-0.1275	-0.0860	0.0149	*****	*****	*****	*****	*****	*****	*****
0.200	-0.1331	-0.0866	0.0001	*****	*****	*****	*****	*****	*****	*****
0.250	*****	-0.0912	-0.0154	-0.1164	-0.2496	*****	*****	*****	*****	*****
0.300	-0.1485	-0.0958	-0.0234	-0.1082	-0.2562	*****	*****	*****	*****	*****
0.350	*****	-0.1016	-0.0390	-0.1026	-0.2568	*****	*****	*****	*****	*****
0.400	-0.1787	-0.1071	-0.0491	-0.1000	-0.2671	*****	*****	*****	*****	*****
0.450	-0.1953	-0.1152	-0.0458	-0.1009	-0.2678	*****	*****	*****	*****	*****
0.500	-0.2139	-0.1237	-0.0753	-0.1028	-0.2744	*****	*****	*****	*****	*****
0.525	*****	-0.1315	-0.0821	-0.1083	-0.2738	*****	*****	*****	*****	*****
0.550	-0.2310	-0.1457	-0.0873	-0.1084	-0.2728	*****	*****	*****	*****	*****
0.575	*****	-0.1524	-0.0840	-0.1143	-0.2787	*****	*****	*****	*****	*****
0.600	-0.2554	-0.1618	-0.1036	-0.1192	-0.2766	*****	*****	*****	*****	*****
0.625	*****	*****	-0.1099	-0.1216	-0.2744	*****	*****	*****	*****	*****
0.650	-0.2788	-0.1782	-0.1179	-0.1284	-0.2721	*****	*****	*****	*****	*****
0.675	*****	-0.2038	-0.1326	-0.1381	-0.2664	*****	*****	*****	*****	*****
0.700	-0.3020	-0.2274	-0.1477	-0.1463	-0.2644	*****	*****	*****	*****	*****
0.725	*****	-0.2503	*****	-0.1585	-0.2648	*****	*****	*****	*****	*****
0.750	-0.3211	-0.2784	*****	-0.1710	-0.2534	*****	*****	*****	*****	*****
0.775	*****	-0.3042	-0.2125	-0.1904	-0.2404	*****	*****	*****	*****	*****
0.800	-0.3384	-0.3361	-0.2476	-0.2144	*****	*****	*****	*****	*****	*****
0.825	*****	-0.3653	-0.2907	-0.2273	-0.2586	*****	*****	*****	*****	*****
0.850	-0.3555	-0.3973	-0.3403	-0.2864	-0.2762	*****	*****	*****	*****	*****
0.875	*****	-0.4309	-0.3916	-0.3429	-0.3769	*****	*****	*****	*****	*****
0.900	-0.3842	-0.4653	-0.4525	-0.4178	-0.5120	*****	*****	*****	*****	*****
0.925	*****	-0.5037	-0.5130	-0.4916	-1.0019	*****	*****	*****	*****	*****
0.950	-0.4292	-0.5444	-0.5818	-0.5729	-0.7241	*****	*****	*****	*****	*****
0.975	*****	-0.6471	-0.6906	-0.6819	-0.6399	*****	*****	*****	*****	*****
1.000	-0.5248	-0.9481	-1.1749	-1.2727	-0.7246	*****	*****	*****	*****	*****
-0.200	$C_{p,l}$	$C_{p,l}$	$C_{p,l}$	$C_{p,l}$	$C_{p,l}$	$C_{p,l}$	$C_{p,l}$	$C_{p,l}$	$C_{p,l}$	$C_{p,l}$
-0.400	0.1198	0.1167	0.1340	*****	*****	-0.3139	*****	*****	*****	*****
-0.600	0.1099	0.1203	0.1096	-0.0078	-0.3529	*****	*****	*****	*****	*****
-0.700	0.1238	0.1234	0.1051	0.0123	-0.3630	*****	*****	*****	*****	*****
-0.800	0.1432	0.1180	0.1071	0.0281	-0.3721	*****	*****	*****	*****	*****
-0.850	0.1755	*****	0.1074	0.0457	-0.3733	*****	*****	*****	*****	*****
-0.900	*****	0.1564	0.1190	0.0533	-0.4065	*****	*****	*****	*****	*****
-0.950	0.2252	0.2082	0.1881	0.1789	-0.4443	*****	*****	*****	*****	*****
-0.975	*****	0.1914	0.1788	0.1357	-0.2420	*****	*****	*****	*****	*****
-1.000	-0.5456	-0.9177	-1.2519	-1.1937	-0.6544	*****	*****	*****	*****	*****

Medium Radius L.E.
 Run No. = 29 , Point No. = 584
 $C_N = 0.229$, $C_m = -0.0329$
 $\alpha = 7.0^\circ$, $M_\infty = 0.399$
 $R_{mac} = 72.8 \times 10^6$

Leading Edge Pressures

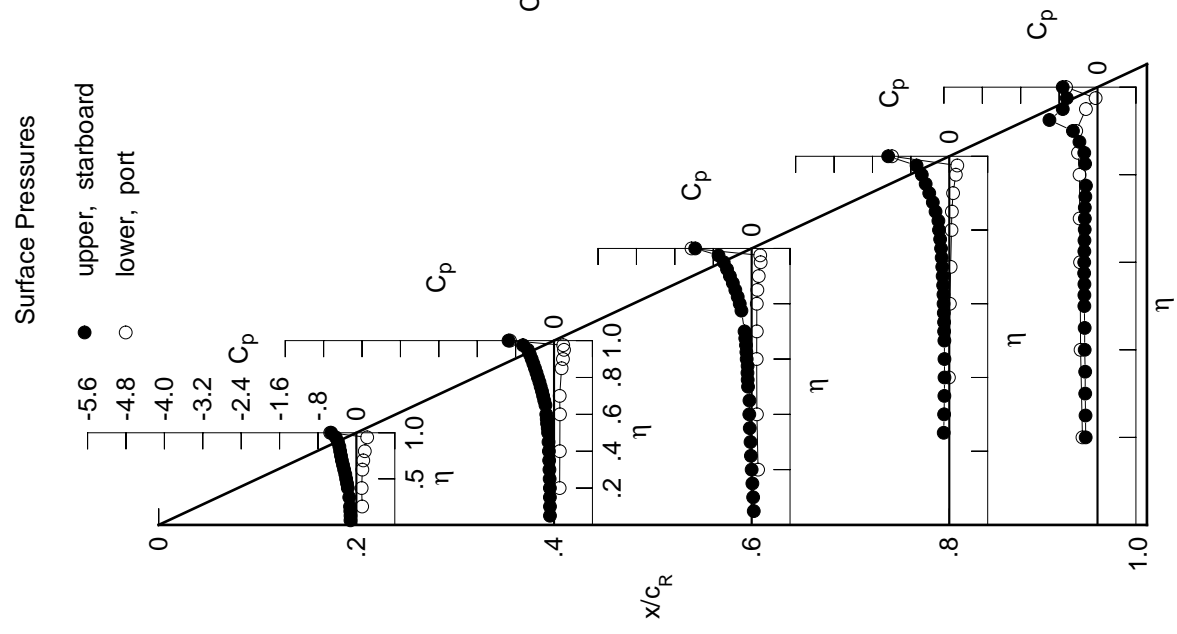
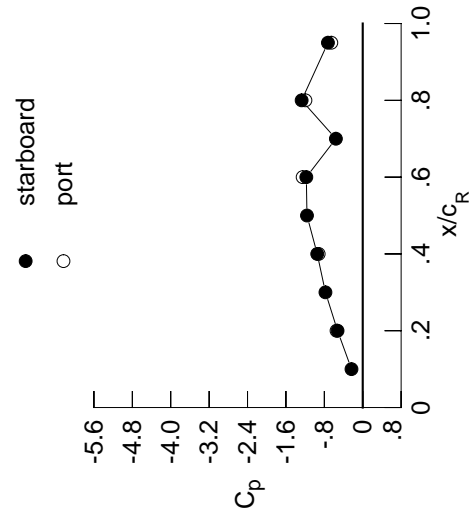

x/c_R	starb'd C_p	port C_p
0.10	-0.2341	*****
0.20	-0.5248	-0.5456
0.30	-0.7767	*****
0.40	-0.9481	-0.9177
0.50	-1.1618	*****
0.60	-1.1749	-1.2519
0.70	-0.5594	*****
0.80	-1.2727	-1.1937
0.90	*****	*****
0.95	-0.7246	-0.6544

Table C3. Continued.

η	$x/c_R = .2$		$x/c_R = .4$		$x/c_R = .6$		$x/c_R = .8$		$x/c_R = .95$	
	$C_{p,u}$	$C_{p,u}$	$C_{p,u}$	$C_{p,u}$	$C_{p,u}$	$C_{p,u}$	$C_{p,u}$	$C_{p,u}$	$C_{p,u}$	$C_{p,u}$
0.050	-0.1400	-0.0980	0.0350	0.0350	0.0350	0.0350	0.0350	0.0350	0.0350	0.0350
0.100	-0.1414	-0.0991	0.0217	0.0217	0.0217	0.0217	0.0217	0.0217	0.0217	0.0217
0.150	-0.1480	-0.1011	0.0039	0.0039	0.0039	0.0039	0.0039	0.0039	0.0039	0.0039
0.200	-0.1524	-0.1012	-0.0108	-0.0108	-0.0108	-0.0108	-0.0108	-0.0108	-0.0108	-0.0108
0.250	*****	-0.1079	-0.0267	-0.0267	-0.0267	-0.0267	-0.0267	-0.0267	-0.0267	-0.0267
0.300	-0.1683	-0.1134	-0.0359	-0.0359	-0.0359	-0.0359	-0.0359	-0.0359	-0.0359	-0.0359
0.350	*****	-0.1196	-0.0509	-0.0509	-0.0509	-0.0509	-0.0509	-0.0509	-0.0509	-0.0509
0.400	-0.2015	-0.1248	-0.0635	-0.0635	-0.0635	-0.0635	-0.0635	-0.0635	-0.0635	-0.0635
0.450	-0.2206	-0.1356	-0.0604	-0.0604	-0.0604	-0.0604	-0.0604	-0.0604	-0.0604	-0.0604
0.500	-0.2421	-0.1461	-0.0909	-0.0909	-0.0909	-0.0909	-0.0909	-0.0909	-0.0909	-0.0909
0.525	*****	-0.1538	-0.0979	-0.0979	-0.0979	-0.0979	-0.0979	-0.0979	-0.0979	-0.0979
0.550	-0.2608	-0.1675	-0.1040	-0.1040	-0.1040	-0.1040	-0.1040	-0.1040	-0.1040	-0.1040
0.575	*****	-0.1771	-0.1022	-0.1022	-0.1022	-0.1022	-0.1022	-0.1022	-0.1022	-0.1022
0.600	-0.2886	-0.1882	-0.1246	-0.1246	-0.1246	-0.1246	-0.1246	-0.1246	-0.1246	-0.1246
0.625	*****	*****	-0.1308	-0.1308	-0.1308	-0.1308	-0.1308	-0.1308	-0.1308	-0.1308
0.650	-0.3161	-0.2060	-0.1395	-0.1395	-0.1395	-0.1395	-0.1395	-0.1395	-0.1395	-0.1395
0.675	*****	-0.2339	-0.1571	-0.1571	-0.1571	-0.1571	-0.1571	-0.1571	-0.1571	-0.1571
0.700	-0.3445	-0.2592	-0.1724	-0.1724	-0.1724	-0.1724	-0.1724	-0.1724	-0.1724	-0.1724
0.725	*****	-0.2854	*****	*****	-0.1792	-0.1792	-0.1792	-0.1792	-0.1792	-0.1792
0.750	-0.3697	-0.3167	*****	*****	-0.1973	-0.1973	-0.1973	-0.1973	-0.1973	-0.1973
0.775	*****	-0.3472	-0.2458	-0.2458	-0.2156	-0.2156	-0.2156	-0.2156	-0.2156	-0.2156
0.800	-0.3948	-0.3841	-0.2843	-0.2843	-0.2414	-0.2414	-0.2414	-0.2414	-0.2414	-0.2414
0.825	*****	-0.4198	-0.3321	-0.3321	-0.2578	-0.2578	-0.2578	-0.2578	-0.2578	-0.2578
0.850	-0.4215	-0.4586	-0.3881	-0.3881	-0.3218	-0.3218	-0.3218	-0.3218	-0.3218	-0.3218
0.875	*****	-0.5006	-0.4519	-0.4519	-0.3849	-0.3849	-0.3849	-0.3849	-0.3849	-0.3849
0.900	-0.4643	-0.5471	-0.5227	-0.5227	-0.4709	-0.4709	-0.4709	-0.4709	-0.4709	-0.4709
0.925	*****	-0.6005	-0.6014	-0.6014	-0.5627	-0.5627	-0.5627	-0.5627	-0.5627	-0.5627
0.950	-0.5361	-0.6608	-0.6933	-0.6933	-0.6684	-0.6684	-0.6684	-0.6684	-0.6684	-0.6684
0.975	*****	-0.8078	-0.8491	-0.8491	-0.8219	-0.8219	-0.8219	-0.8219	-0.8219	-0.8219
1.000	-0.7815	-1.3244	-1.6583	-1.6583	-1.7651	-1.7651	-1.7651	-1.7651	-1.7651	-1.7651
-0.200	$C_{p,l}$	$C_{p,l}$	$C_{p,l}$	$C_{p,l}$	$C_{p,l}$	$C_{p,l}$	$C_{p,l}$	$C_{p,l}$	$C_{p,l}$	$C_{p,l}$
-0.400	0.1390	0.1319	0.1460	0.1460	0.1460	0.1460	0.1460	0.1460	0.1460	0.1460
-0.600	0.1310	0.1371	0.1213	0.1213	0.0025	0.0025	-0.3573	-0.3573	-0.3573	-0.3573
-0.700	0.1474	0.1420	0.1208	0.1208	0.0216	0.0216	-0.3714	-0.3714	-0.3714	-0.3714
-0.800	0.1667	0.1385	0.1231	0.1231	0.0402	0.0402	-0.3808	-0.3808	-0.3808	-0.3808
-0.850	0.1984	*****	0.1268	0.1268	0.0596	0.0596	-0.3803	-0.3803	-0.3803	-0.3803
-0.900	*****	0.1789	0.1401	0.1401	0.0699	0.0699	-0.4090	-0.4090	-0.4090	-0.4090
-0.950	*****	0.2043	0.1665	0.1665	0.0983	0.0983	-0.4365	-0.4365	-0.4365	-0.4365
-0.975	0.2183	0.2090	0.1946	0.1946	0.1485	0.1485	-0.2175	-0.2175	-0.2175	-0.2175
-1.000	*****	0.1609	0.1573	0.1573	0.1567	0.1567	-0.0236	-0.0236	-0.0236	-0.0236
-1.000	-0.8038	-1.3023	-1.7510	-1.7510	-1.6736	-1.6736	-0.9262	-0.9262	-0.9262	-0.9262

Medium Radius L.E.
 Run No. = 29 , Point No. = 585
 $C_N = 0.262$, $C_m = -0.0365$
 $\alpha = 8.0^\circ$, $M_\infty = 0.399$
 $R_{mac} = 72.7 \times 10^6$

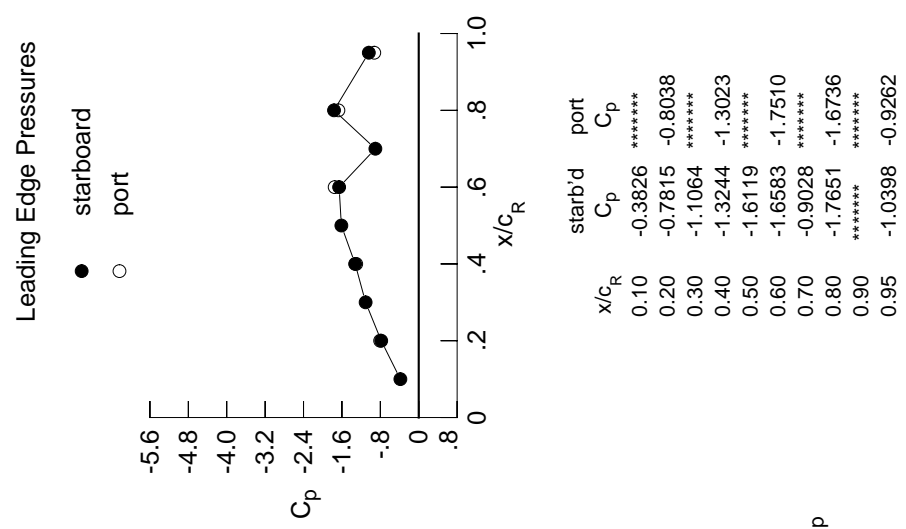
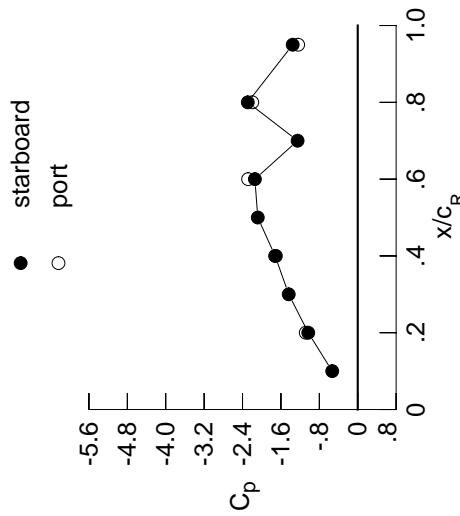

Table C3. Continued.

η	$x/c_R = .2$		$x/c_R = .4$		$x/c_R = .6$		$x/c_R = .8$		$x/c_R = .95$	
	$C_{p,u}$	$C_{p,u}$	$C_{p,u}$	$C_{p,u}$	$C_{p,u}$	$C_{p,u}$	$C_{p,u}$	$C_{p,u}$	$C_{p,u}$	$C_{p,u}$
0.050	-0.1514	-0.1070	0.0292	*****	*****	*****	*****	*****	*****	
0.100	-0.1558	-0.1099	0.0161	*****	*****	*****	*****	*****	*****	
0.150	-0.1624	-0.1110	-0.0028	*****	*****	*****	*****	*****	*****	
0.200	-0.1687	-0.1129	-0.0169	*****	*****	*****	*****	*****	-0.2597	
0.250	*****	-0.1207	0.0348	-0.1277	-0.2547	*****	*****	*****	*****	
0.300	-0.1863	-0.1243	-0.0436	-0.1200	-0.2536	*****	*****	*****	*****	
0.350	*****	-0.1326	-0.0604	-0.1143	-0.2501	*****	*****	*****	*****	
0.400	-0.2204	-0.1395	-0.0726	-0.1135	-0.2616	*****	*****	*****	*****	
0.450	-0.2404	-0.1509	-0.0704	-0.1165	-0.2605	*****	*****	*****	*****	
0.500	-0.2640	-0.1634	-0.1024	-0.1198	-0.2679	*****	*****	*****	*****	
0.525	*****	-0.1718	-0.1098	-0.1264	-0.2665	*****	*****	*****	*****	
0.550	-0.2853	-0.1863	-0.1174	-0.1284	-0.2661	*****	*****	*****	*****	
0.575	*****	-0.1962	-0.1164	-0.1359	-0.2728	*****	*****	*****	*****	
0.600	-0.3164	-0.2082	-0.1403	-0.1417	-0.2720	*****	*****	*****	*****	
0.625	*****	*****	-0.1476	-0.1474	-0.2700	*****	*****	*****	*****	
0.650	-0.3482	-0.2291	-0.1582	-0.1580	-0.2704	*****	*****	*****	*****	
0.675	*****	-0.2586	-0.1777	-0.1692	-0.2679	*****	*****	*****	*****	
0.700	-0.3809	-0.2855	-0.1948	-0.1818	-0.2679	*****	*****	*****	*****	
0.725	*****	-0.3147	*****	-0.1991	-0.2720	*****	*****	*****	*****	
0.750	-0.4127	-0.3493	*****	-0.2179	-0.2652	*****	*****	*****	*****	
0.775	*****	-0.3834	-0.2724	-0.2394	-0.2615	*****	*****	*****	*****	
0.800	-0.4449	-0.4260	-0.3146	-0.2658	*****	*****	*****	*****	*****	
0.825	*****	-0.4667	-0.3661	-0.2843	-0.2574	*****	*****	*****	*****	
0.850	-0.4820	-0.5132	-0.4298	-0.3486	-0.2654	*****	*****	*****	*****	
0.875	*****	-0.5630	-0.5016	-0.4183	-0.3594	*****	*****	*****	*****	
0.900	-0.5386	-0.6210	-0.5861	-0.5150	-0.5052	*****	*****	*****	*****	
0.925	*****	-0.6897	-0.6781	-0.6242	-1.0219	*****	*****	*****	*****	
0.950	-0.6384	-0.7723	-0.7972	-0.7516	-0.8159	*****	*****	*****	*****	
0.975	*****	-0.9638	-0.9946	-0.9529	-0.8004	*****	*****	*****	*****	
1.000	-1.0302	-1.7209	-2.1425	-2.2907	-1.3548	*****	*****	*****	*****	
$C_{p,l}$	$C_{p,l}$	$C_{p,l}$	$C_{p,l}$	$C_{p,l}$	$C_{p,l}$	$C_{p,l}$	$C_{p,l}$	$C_{p,l}$	$C_{p,l}$	
-0.200	0.1586	0.1495	0.1597	*****	-0.3061	*****	*****	*****	*****	
-0.400	0.1528	0.1545	0.1362	0.0127	-0.3562	*****	*****	*****	*****	
-0.600	0.1717	0.1612	0.1351	0.0343	-0.3732	*****	*****	*****	*****	
-0.700	0.1909	0.1606	0.1393	0.0627	-0.3837	*****	*****	*****	*****	
-0.800	0.2188	*****	0.1454	0.0751	-0.3823	*****	*****	*****	*****	
-0.850	*****	0.1997	0.1601	0.0875	-0.4058	*****	*****	*****	*****	
-0.900	*****	0.2193	0.1844	0.1175	-0.4229	*****	*****	*****	*****	
-0.950	0.2079	0.2063	0.1967	0.1591	-0.1901	*****	*****	*****	*****	
-0.975	*****	0.1246	0.1318	0.1450	-0.0068	*****	*****	*****	*****	
-1.000	-1.0830	-1.7053	-2.2841	-2.1964	-1.2408	*****	*****	*****	*****	

Medium Radius L.E.
 Run No. = 29 , Point No. = 586
 $C_N = 0.297$, $C_m = -0.0412$
 $\alpha = 9.0^\circ$, $M_\infty = 0.399$
 $R_{mac} = 72.7 \times 10^6$

Leading Edge Pressures



x/c_R	starb'd C_p	port C_p
0.10	-0.5316	*****
0.20	-1.0302	-1.0830
0.30	-1.4373	*****
0.40	-1.7209	-1.7053
0.50	-2.0821	*****
0.60	-2.1425	-2.2841
0.70	-1.2524	*****
0.80	-2.2907	-2.1964
0.90	*****	*****
0.95	-1.3548	-1.2408

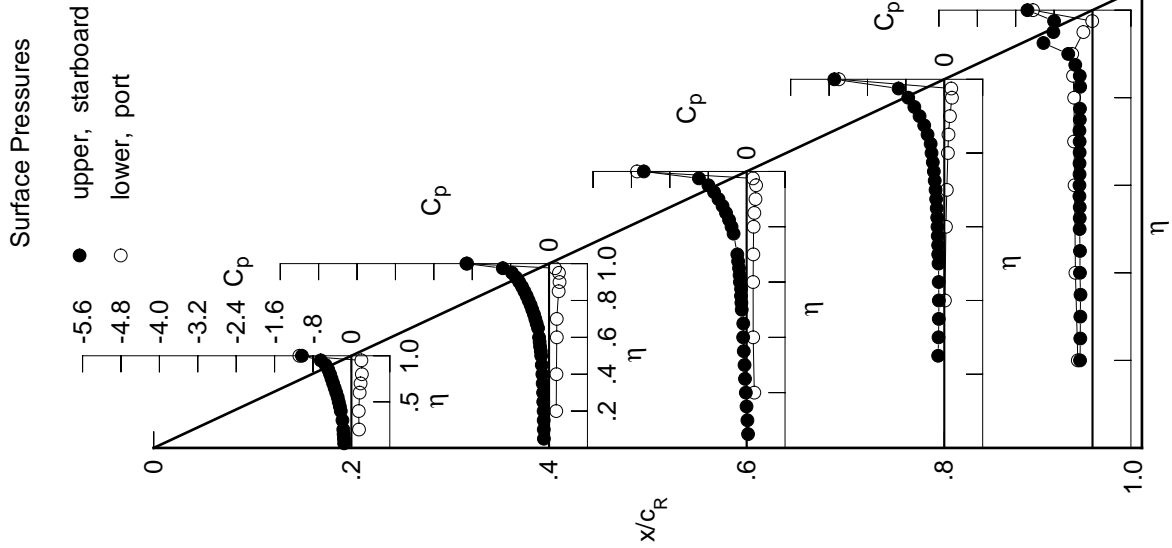
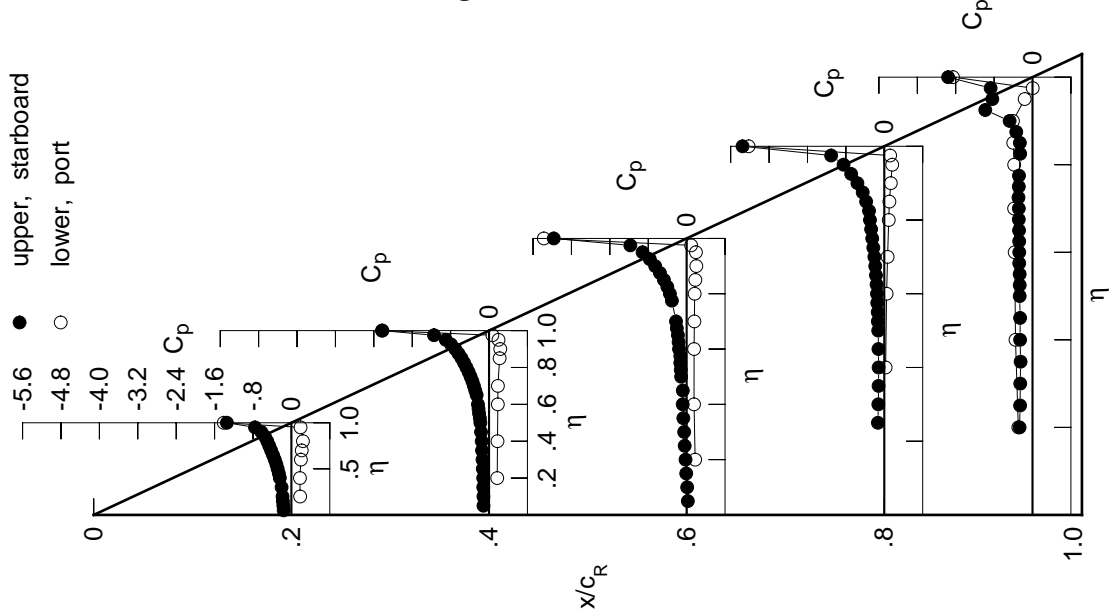

Table C3. Continued.

η	$x/c_R = .2$		$x/c_R = .4$		$x/c_R = .6$		$x/c_R = .8$		$x/c_R = .95$	
	$C_{p,u}$	$C_{p,u}$	$C_{p,u}$	$C_{p,u}$	$C_{p,u}$	$C_{p,u}$	$C_{p,u}$	$C_{p,u}$	$C_{p,u}$	$C_{p,u}$
0.050	-0.1605	-0.1163	0.0248	*****	*****	*****	*****	*****	*****	*****
0.100	-0.1678	-0.1169	0.0109	*****	*****	*****	*****	*****	*****	*****
0.150	-0.1780	-0.1209	-0.0090	*****	*****	*****	*****	*****	*****	*****
0.200	-0.1841	-0.1213	-0.0231	*****	*****	*****	*****	*****	*****	-0.2695
0.250	*****	-0.1297	-0.0412	-0.1326	-0.2580	*****	*****	*****	*****	*****
0.300	-0.2039	-0.1360	-0.0511	-0.1238	-0.2554	*****	*****	*****	*****	*****
0.350	*****	-0.1457	-0.0685	-0.1194	-0.2479	*****	*****	*****	*****	*****
0.400	-0.2407	-0.1527	-0.0823	-0.1187	-0.2583	*****	*****	*****	*****	*****
0.450	-0.2615	-0.1665	-0.0800	-0.1216	-0.2581	*****	*****	*****	*****	*****
0.500	-0.2867	-0.1807	-0.1142	-0.1265	-0.2669	*****	*****	*****	*****	*****
0.525	*****	-0.1914	-0.1230	-0.1342	-0.2664	*****	*****	*****	*****	*****
0.550	-0.3126	-0.2076	-0.1319	-0.1368	-0.2676	*****	*****	*****	*****	*****
0.575	*****	-0.2186	-0.1320	-0.1463	-0.2764	*****	*****	*****	*****	*****
0.600	-0.3464	-0.2312	-0.1585	-0.1521	-0.2763	*****	*****	*****	*****	*****
0.625	*****	*****	-0.1672	-0.1602	-0.2772	*****	*****	*****	*****	*****
0.650	-0.3833	-0.2579	-0.1813	-0.1733	-0.2808	*****	*****	*****	*****	*****
0.675	*****	-0.2864	-0.2038	-0.1880	-0.2857	*****	*****	*****	*****	*****
0.700	-0.4228	-0.3153	-0.2218	-0.2061	-0.2859	*****	*****	*****	*****	*****
0.725	*****	-0.3462	*****	-0.2284	-0.2924	*****	*****	*****	*****	*****
0.750	-0.4614	-0.3844	*****	-0.2512	-0.2857	*****	*****	*****	*****	*****
0.775	*****	-0.4251	-0.3072	-0.2746	-0.2817	*****	*****	*****	*****	*****
0.800	-0.5021	-0.4702	-0.3484	-0.2987	*****	*****	*****	*****	*****	*****
0.825	*****	-0.5196	-0.4027	-0.3184	-0.2569	*****	*****	*****	*****	*****
0.850	-0.5507	-0.5728	-0.4726	-0.3785	-0.2635	*****	*****	*****	*****	*****
0.875	*****	-0.6353	-0.5564	-0.4495	-0.3385	*****	*****	*****	*****	*****
0.900	-0.6259	-0.7036	-0.6552	-0.5698	-0.4768	*****	*****	*****	*****	*****
0.925	*****	-0.7913	-0.7675	-0.6900	-0.9844	*****	*****	*****	*****	*****
0.950	-0.7583	-0.9005	-0.9179	-0.8487	-0.8365	*****	*****	*****	*****	*****
0.975	*****	-1.1467	-1.1740	-1.1078	-0.8732	*****	*****	*****	*****	*****
1.000	-1.3440	-2.2310	-2.7680	-2.9525	-1.7581	*****	*****	*****	*****	*****
-0.200	$C_{p,l}$	0.1825	0.1705	0.1773	*****	-0.2956	$C_{p,l}$	0.1825	0.1705	0.1773
-0.400	$C_{p,l}$	0.1784	0.1760	0.1539	0.0276	-0.3545	$C_{p,l}$	0.1784	0.1760	0.1539
-0.600	$C_{p,l}$	0.1976	0.1834	0.1549	0.0479	-0.3713	$C_{p,l}$	0.1976	0.1834	0.1549
-0.700	$C_{p,l}$	0.2161	0.1845	0.1609	0.0687	-0.3830	$C_{p,l}$	0.2161	0.1845	0.1609
-0.800	$C_{p,l}$	0.2406	*****	0.1676	0.0925	-0.3815	$C_{p,l}$	0.2406	*****	0.1676
-0.850	$C_{p,l}$	*****	0.2209	0.1811	0.1067	-0.4008	$C_{p,l}$	*****	0.2209	0.1811
-0.900	$C_{p,l}$	*****	0.2341	0.2013	0.1364	-0.4070	$C_{p,l}$	*****	0.2341	0.2013
-0.950	$C_{p,l}$	0.1906	0.1967	0.1933	0.1646	-0.1630	$C_{p,l}$	0.1906	0.1967	0.1933
-0.975	$C_{p,l}$	*****	0.0696	0.0936	0.1213	0.0044	$C_{p,l}$	*****	0.0696	0.0936
-1.000	$C_{p,l}$	-1.4089	-2.2210	-2.9750	-2.8270	-1.6564	$C_{p,l}$	-1.4089	-2.2210	-2.9750

Surface Pressures



Medium Radius L.E.
 Run No. = 29 , Point No. = 587
 $C_N = 0.336$, $C_m = -0.0479$
 $\alpha = 10.0^\circ$, $M_\infty = 0.399$
 $R_{mac} = 72.6 \times 10^6$

Leading Edge Pressures

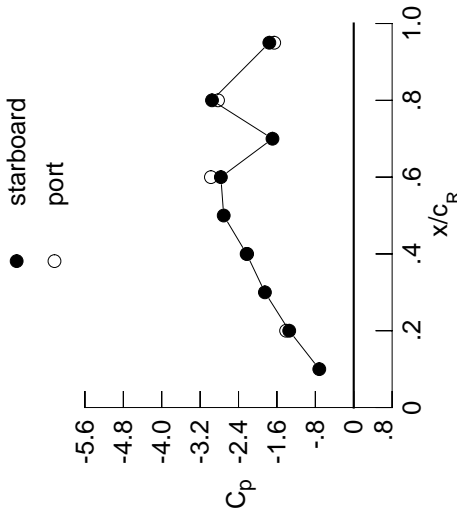

x/c_R	starb'd C_p	port C_p
0.10	-0.7178	*****
0.20	-1.3440	-1.4089
0.30	-1.8508	*****
0.40	-2.2310	-2.2210
0.50	-2.7092	*****
0.60	-2.7680	-2.9750
0.70	-1.6925	*****
0.80	-2.9525	-2.8270
0.90	*****	*****
0.95	-1.7581	-1.6564

Table C3. Continued.

η	$x/c_R = .2$		$x/c_R = .4$		$x/c_R = .6$		$x/c_R = .8$		$x/c_R = .95$	
	$C_{p,u}$	$C_{p,u}$	$C_{p,u}$	$C_{p,u}$	$C_{p,u}$	$C_{p,u}$	$C_{p,u}$	$C_{p,u}$	$C_{p,u}$	$C_{p,u}$
0.050	-0.1743	-0.1260	0.0166	*****	*****	*****	*****	*****	*****	*****
0.100	-0.1816	-0.1281	0.0029	*****	*****	*****	*****	*****	*****	*****
0.150	-0.1945	-0.1321	-0.0172	*****	*****	*****	*****	*****	*****	*****
0.200	-0.2044	-0.1361	-0.0322	*****	*****	*****	*****	*****	*****	-0.2764
0.250	*****	-0.1439	-0.0510	-0.1380	-0.1380	-0.1380	-0.1380	-0.1380	-0.1380	-0.2652
0.300	-0.2232	-0.1518	-0.0623	-0.1318	-0.1318	-0.1318	-0.1318	-0.1318	-0.1318	-0.2585
0.350	*****	-0.1622	-0.0797	-0.1275	-0.1275	-0.1275	-0.1275	-0.1275	-0.1275	-0.2509
0.400	-0.2603	-0.1711	-0.0936	-0.1260	-0.1260	-0.1260	-0.1260	-0.1260	-0.1260	-0.2599
0.450	-0.2844	-0.1879	-0.0946	-0.1305	-0.1305	-0.1305	-0.1305	-0.1305	-0.1305	-0.2607
0.500	-0.3122	-0.2039	-0.1296	-0.1357	-0.1357	-0.1357	-0.1357	-0.1357	-0.1357	-0.2709
0.525	*****	-0.2154	-0.1399	-0.1430	-0.1430	-0.1430	-0.1430	-0.1430	-0.1430	-0.2713
0.550	-0.3407	-0.2324	-0.1507	-0.1465	-0.1465	-0.1465	-0.1465	-0.1465	-0.1465	-0.2735
0.575	*****	-0.2443	-0.1540	-0.1544	-0.1544	-0.1544	-0.1544	-0.1544	-0.1544	-0.2830
0.600	-0.3774	-0.2596	-0.1835	-0.1636	-0.1636	-0.1636	-0.1636	-0.1636	-0.1636	-0.2869
0.625	*****	*****	-0.1946	-0.1727	-0.1727	-0.1727	-0.1727	-0.1727	-0.1727	-0.2878
0.650	-0.4194	-0.2868	-0.2133	-0.1914	-0.1914	-0.1914	-0.1914	-0.1914	-0.1914	-0.2974
0.675	*****	-0.3178	-0.2379	-0.2158	-0.2158	-0.2158	-0.2158	-0.2158	-0.2158	-0.3167
0.700	-0.4643	-0.3474	-0.2604	-0.2466	-0.2466	-0.2466	-0.2466	-0.2466	-0.2466	-0.3377
0.725	*****	-0.3800	*****	-0.2815	-0.2815	-0.2815	-0.2815	-0.2815	-0.2815	-0.3654
0.750	-0.5107	-0.4203	*****	-0.3180	-0.3180	-0.3180	-0.3180	-0.3180	-0.3180	-0.3776
0.775	*****	-0.4634	-0.3455	-0.3426	-0.3426	-0.3426	-0.3426	-0.3426	-0.3426	-0.3802
0.800	-0.5608	-0.5156	-0.3853	-0.3584	*****	*****	*****	*****	*****	*****
0.825	*****	-0.5722	-0.4365	-0.3761	-0.3418	-0.3418	-0.3418	-0.3418	-0.3418	-0.3418
0.850	-0.6221	-0.6335	-0.5110	-0.4168	-0.4168	-0.4168	-0.4168	-0.4168	-0.4168	-0.3433
0.875	*****	-0.7078	-0.6042	-0.4692	-0.4692	-0.4692	-0.4692	-0.4692	-0.4692	-0.3665
0.900	-0.7153	-0.7900	-0.7192	-0.5807	-0.5807	-0.5807	-0.5807	-0.5807	-0.5807	-0.4633
0.925	*****	-0.8954	-0.8526	-0.7346	-0.7346	-0.7346	-0.7346	-0.7346	-0.7346	-0.9117
0.950	-0.8840	-1.0333	-1.0342	-0.9310	-0.9310	-0.9310	-0.9310	-0.9310	-0.9310	-0.8390
0.975	*****	-1.3375	-1.3492	-1.2510	-0.9337	-0.9337	-0.9337	-0.9337	-0.9337	-0.9337
1.000	-1.6928	-2.8289	-3.1570	-3.6817	-2.1965	-2.1965	-2.1965	-2.1965	-2.1965	-2.1965
-0.200	$C_{p,l}$	0.2049	0.1886	0.1916	*****	*****	*****	*****	*****	-0.2871
-0.400	$C_{p,l}$	0.2002	0.1951	0.1699	0.0401	-0.3490	-0.3490	-0.3490	-0.3490	-0.3490
-0.600	$C_{p,l}$	0.2207	0.2037	0.1713	0.0627	-0.3604	-0.3604	-0.3604	-0.3604	-0.3604
-0.700	$C_{p,l}$	0.2374	0.2049	0.1782	0.0842	-0.3745	-0.3745	-0.3745	-0.3745	-0.3745
-0.800	$C_{p,l}$	0.2573	*****	0.1853	0.1089	-0.3744	-0.3744	-0.3744	-0.3744	-0.3744
-0.850	$C_{p,l}$	*****	0.2370	0.1986	0.1224	-0.3937	-0.3937	-0.3937	-0.3937	-0.3937
-0.900	$C_{p,l}$	*****	0.2406	0.2127	0.1508	-0.3918	-0.3918	-0.3918	-0.3918	-0.3918
-0.950	$C_{p,l}$	0.1648	0.1777	0.1814	0.1634	-0.1413	-0.1413	-0.1413	-0.1413	-0.1413
-0.975	$C_{p,l}$	*****	0.0071	0.0420	0.0884	0.0080	0.0080	0.0080	0.0080	0.0080
-1.000	$C_{p,l}$	-1.7802	-2.8054	-3.7697	-3.5624	-3.5624	-3.5624	-3.5624	-3.5624	-3.5624

Medium Radius L.E.
 Run No. = 29 , Point No. = 588
 $C_N = 0.378$, $C_m = -0.0559$
 $\alpha = 11.1^\circ$, $M_\infty = 0.399$
 $R_{mac} = 72.6 \times 10^6$

Leading Edge Pressures

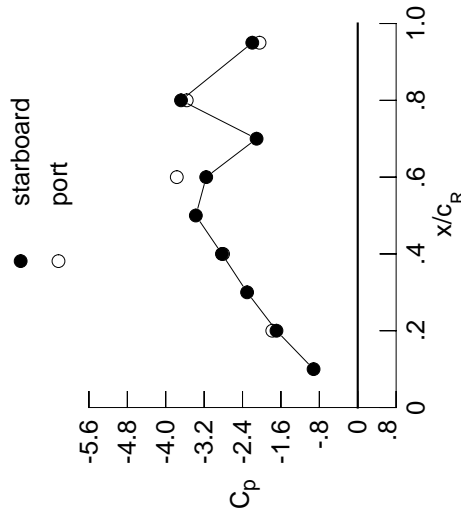

x/c_R	starb'd C_p	port C_p
0.10	-0.9203	*****
0.20	-1.6928	-1.7802
0.30	-2.3050	*****
0.40	-2.8289	-2.8054
0.50	-3.3727	*****
0.60	-3.1570	-3.7697
0.70	-2.1074	*****
0.80	-3.6817	-3.5624
0.90	*****	*****
0.95	-2.1965	-2.0455

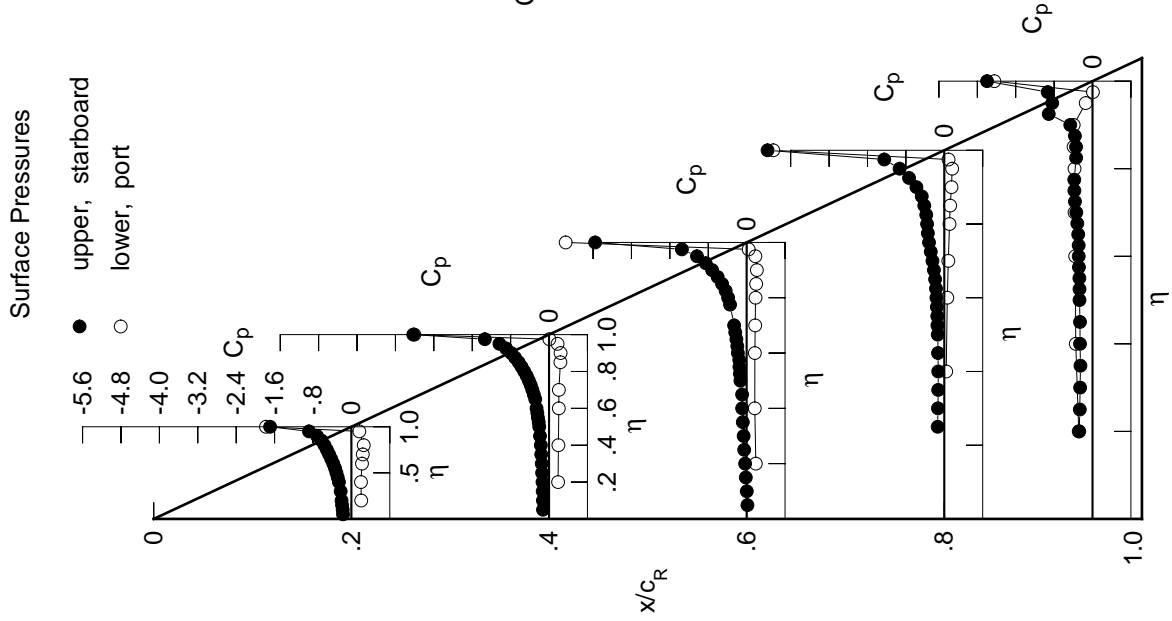
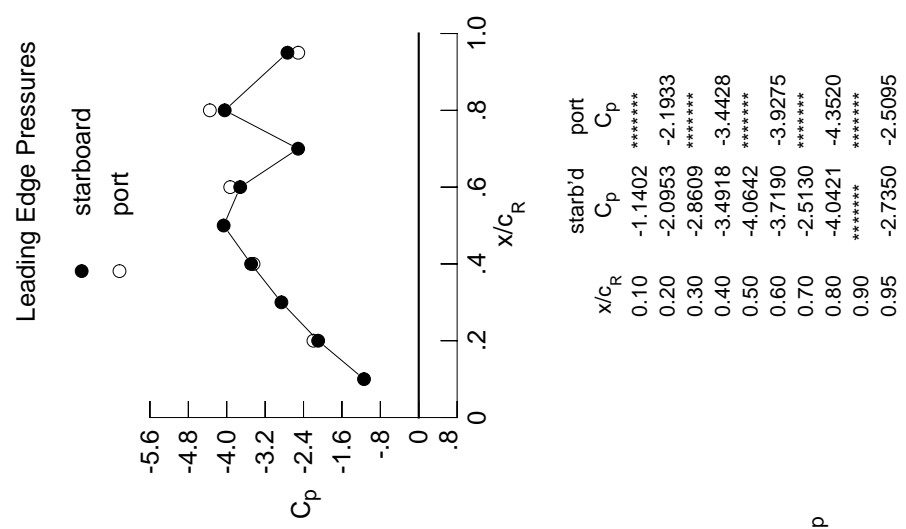

Table C3. Continued.

η	$x/c_R = .2$		$x/c_R = .4$		$x/c_R = .6$		$x/c_R = .8$		$x/c_R = .95$	
	$C_{p,u}$	$C_{p,u}$	$C_{p,u}$	$C_{p,u}$	$C_{p,u}$	$C_{p,u}$	$C_{p,u}$	$C_{p,u}$	$C_{p,u}$	$C_{p,u}$
0.050	-0.1857	-0.1383	0.0106	*****	*****	*****	*****	*****	*****	
0.100	-0.1899	-0.1368	-0.0025	*****	*****	*****	*****	*****	*****	
0.150	-0.2073	-0.1407	-0.0224	*****	*****	*****	*****	*****	*****	
0.200	-0.2194	-0.1460	-0.0401	*****	*****	*****	*****	*****	-0.2844	
0.250	*****	-0.1558	-0.0590	-0.1446	-0.1446	-0.1446	-0.1446	-0.1446	-0.2743	
0.300	-0.2451	-0.1646	-0.0710	-0.1380	-0.1380	-0.1380	-0.1380	-0.1380	-0.2651	
0.350	*****	-0.1770	-0.0893	-0.1348	-0.1348	-0.1348	-0.1348	-0.1348	-0.2547	
0.400	-0.2832	-0.1886	-0.1046	-0.1342	-0.1342	-0.1342	-0.1342	-0.1342	-0.2630	
0.450	-0.3067	-0.2079	-0.1041	-0.1386	-0.1386	-0.1386	-0.1386	-0.1386	-0.2623	
0.500	-0.3362	-0.2289	-0.1423	-0.1418	-0.1418	-0.1418	-0.1418	-0.1418	-0.2727	
0.525	*****	-0.2431	-0.1551	-0.1494	-0.1494	-0.1494	-0.1494	-0.1494	-0.2738	
0.550	-0.3681	-0.2618	-0.1683	-0.1506	-0.1506	-0.1506	-0.1506	-0.1506	-0.2799	
0.575	*****	-0.2752	-0.1759	-0.1566	-0.1566	-0.1566	-0.1566	-0.1566	-0.2977	
0.600	-0.4076	-0.2910	-0.2128	-0.1595	-0.1595	-0.1595	-0.1595	-0.1595	-0.3066	
0.625	*****	*****	*****	-0.2293	-0.1632	-0.1632	-0.1632	-0.1632	-0.3019	
0.650	-0.4543	-0.3230	-0.2595	-0.1864	-0.1864	-0.1864	-0.1864	-0.1864	-0.2962	
0.675	*****	-0.3532	-0.2916	-0.2438	-0.2438	-0.2438	-0.2438	-0.2438	-0.3097	
0.700	-0.5052	-0.3804	-0.3199	-0.3047	-0.3047	-0.3047	-0.3047	-0.3047	-0.3534	
0.725	*****	-0.4140	*****	-0.3554	-0.4312	-0.4312	-0.4312	-0.4312	-0.3554	
0.750	-0.5601	-0.4553	*****	-0.4292	-0.4292	-0.4292	-0.4292	-0.4292	-0.5656	
0.775	*****	-0.5011	-0.4076	-0.5115	-0.6673	-0.6673	-0.6673	-0.6673	*****	
0.800	-0.6197	-0.5586	-0.4379	-0.5372	*****	*****	*****	*****	*****	
0.825	*****	-0.6232	-0.4785	-0.4974	-0.5524	-0.5524	-0.5524	-0.5524	-0.5524	
0.850	-0.6953	-0.6936	-0.5398	-0.5208	-0.5099	-0.5099	-0.5099	-0.5099	-0.5099	
0.875	*****	-0.7802	-0.6367	-0.5636	-0.4959	-0.4959	-0.4959	-0.4959	-0.4959	
0.900	-0.8081	-0.8785	-0.7691	-0.5925	-0.4986	-0.4986	-0.4986	-0.4986	-0.4986	
0.925	*****	-1.0048	-0.9295	-0.6866	-0.6416	-0.6416	-0.6416	-0.6416	-0.6416	
0.950	-1.0172	-1.1723	-1.1494	-0.9326	-0.8183	-0.8183	-0.8183	-0.8183	-0.8183	
0.975	*****	-1.5421	-1.5286	-1.3452	-1.0073	-1.0073	-1.0073	-1.0073	-1.0073	
1.000	-2.0953	-3.4918	-3.7190	-4.0421	-2.7350	-2.7350	-2.7350	-2.7350	-2.7350	
-0.200	$C_{p,l}$	0.2287	0.2102	0.2078	*****	*****	*****	*****	-0.2769	
-0.400	$C_{p,l}$	0.2248	0.2160	0.1891	0.0579	-0.3380	-0.3380	-0.3380	-0.3380	
-0.600	$C_{p,l}$	0.2449	0.2242	0.1901	0.0799	-0.3368	-0.3368	-0.3368	-0.3368	
-0.700	$C_{p,l}$	0.2604	0.2268	0.1969	0.1031	-0.3431	-0.3431	-0.3431	-0.3431	
-0.800	$C_{p,l}$	0.2741	*****	0.2042	0.1272	-0.3479	-0.3479	-0.3479	-0.3479	
-0.850	$C_{p,l}$	*****	0.2518	0.2152	0.1419	-0.3681	-0.3681	-0.3681	-0.3681	
-0.900	$C_{p,l}$	*****	0.2451	0.2226	0.1668	-0.3606	-0.3606	-0.3606	-0.3606	
-0.950	$C_{p,l}$	0.1323	0.1544	0.1660	0.1615	-0.1104	-0.1104	-0.1104	-0.1104	
-0.975	$C_{p,l}$	*****	-0.0618	-0.0151	0.0512	0.0138	0.0138	0.0138	0.0138	
-1.000	$C_{p,l}$	-2.1933	-3.4428	-3.9275	-4.3520	-2.5095	-2.5095	-2.5095	-2.5095	

Medium Radius L.E.
 Run No. = 29 , Point No. = 589
 $C_N = 0.427$, $C_m = -0.0680$
 $\alpha = 12.1^\circ$, $M_\infty = 0.399$
 $R_{mac} = 72.6 \times 10^6$



x/c_R	starb'd C_p	port C_p
0.10	-1.1402	*****
0.20	-2.0953	-2.1933
0.30	-2.8609	*****
0.40	-3.4918	-3.4428
0.50	-4.0642	*****
0.60	-3.7190	-3.9275
0.70	-2.5130	*****
0.80	-4.0421	-4.3520
0.90	*****	*****
0.95	-2.7350	-2.5095

Table C3. Continued.

η	$x/c_R = .2$		$x/c_R = .4$		$x/c_R = .6$		$x/c_R = .8$		$x/c_R = .95$	
	$C_{p,u}$	$C_{p,u}$	$C_{p,u}$	$C_{p,u}$	$C_{p,u}$	$C_{p,u}$	$C_{p,u}$	$C_{p,u}$	$C_{p,u}$	$C_{p,u}$
0.050	-0.2021	-0.1537	-0.0047	*****	*****	*****	*****	*****	*****	*****
0.100	-0.2030	-0.1523	-0.0180	*****	*****	*****	*****	*****	*****	*****
0.150	-0.2196	-0.1535	-0.0370	*****	*****	*****	*****	*****	*****	*****
0.200	-0.2412	-0.1584	-0.0557	*****	*****	*****	*****	*****	*****	*****
0.250	*****	-0.1731	-0.0760	-0.1630	-0.2949	*****	*****	*****	*****	-0.3009
0.300	-0.2707	-0.1821	-0.0885	-0.1580	-0.2843	*****	*****	*****	*****	*****
0.350	*****	-0.1974	-0.1068	-0.1556	-0.2710	*****	*****	*****	*****	*****
0.400	-0.3091	-0.2127	-0.1233	-0.1541	-0.2777	*****	*****	*****	*****	*****
0.450	-0.3320	-0.2372	-0.1217	-0.1568	-0.2861	*****	*****	*****	*****	*****
0.500	-0.3629	-0.2650	-0.1591	-0.1614	-0.3035	*****	*****	*****	*****	*****
0.525	*****	-0.2814	-0.1724	-0.1724	-0.3039	*****	*****	*****	*****	*****
0.550	-0.3969	-0.3043	-0.1882	-0.1773	-0.2919	*****	*****	*****	*****	*****
0.575	*****	-0.3209	-0.1989	-0.1946	-0.2947	*****	*****	*****	*****	*****
0.600	-0.4408	-0.3372	-0.2517	-0.2108	-0.3055	*****	*****	*****	*****	*****
0.625	*****	*****	-0.2863	-0.2085	-0.3176	*****	*****	*****	*****	*****
0.650	-0.4921	-0.3726	-0.3324	-0.2001	-0.3266	*****	*****	*****	*****	*****
0.675	*****	-0.4000	-0.3754	-0.1881	-0.3329	*****	*****	*****	*****	*****
0.700	-0.5499	-0.4248	-0.4050	-0.1746	-0.3325	*****	*****	*****	*****	*****
0.725	*****	-0.4553	*****	-0.1775	-0.3448	*****	*****	*****	*****	*****
0.750	-0.6128	-0.4943	*****	-0.1773	-0.3942	*****	*****	*****	*****	*****
0.775	*****	-0.5408	-0.5393	-0.2145	-0.5646	*****	*****	*****	*****	*****
0.800	-0.6829	-0.6015	-0.5889	-0.5501	*****	*****	*****	*****	*****	*****
0.825	*****	-0.6734	-0.6432	-1.1136	-0.9108	*****	*****	*****	*****	*****
0.850	-0.7725	-0.7531	-0.7109	-1.3342	-0.9397	*****	*****	*****	*****	*****
0.875	*****	-0.8541	-0.7709	-1.1522	-0.8741	*****	*****	*****	*****	*****
0.900	-0.9074	-0.9681	-0.8472	-1.0380	-0.7278	*****	*****	*****	*****	*****
0.925	*****	-1.1171	-0.9620	-1.2517	-0.6303	*****	*****	*****	*****	*****
0.950	-1.1602	-1.3199	-1.1843	-1.3000	-0.5445	*****	*****	*****	*****	*****
0.975	*****	-1.7584	-1.6026	-1.0524	-0.4706	*****	*****	*****	*****	*****
1.000	-2.5463	-4.0127	-4.1648	-2.0748	-0.7770	*****	*****	*****	*****	*****
-0.200	$C_{p,l}$	$C_{p,l}$	$C_{p,l}$	$C_{p,l}$	$C_{p,l}$	$C_{p,l}$	$C_{p,l}$	$C_{p,l}$	$C_{p,l}$	$C_{p,l}$
-0.400	0.2515	0.2306	0.2259	*****	*****	*****	*****	*****	*****	-0.2830
-0.600	0.2479	0.2373	0.2080	0.0728	-0.3404	*****	*****	*****	*****	*****
-0.700	0.2680	0.2464	0.2102	0.0959	-0.3441	*****	*****	*****	*****	*****
-0.800	0.2796	0.2477	0.2175	0.1215	-0.3414	*****	*****	*****	*****	*****
-0.850	0.2863	*****	0.2251	0.1502	-0.3336	*****	*****	*****	*****	*****
-0.900	*****	0.2640	0.2333	0.1658	-0.3591	*****	*****	*****	*****	*****
-0.950	*****	0.2443	0.2331	0.1934	-0.3612	*****	*****	*****	*****	*****
-0.975	0.0927	0.1208	0.1482	0.1922	-0.1251	*****	*****	*****	*****	*****
-1.000	*****	-0.1480	-0.0783	0.1016	0.0111	*****	*****	*****	*****	*****
	-2.6468	-4.1061	-3.9269	-1.9061	-0.8133	*****	*****	*****	*****	*****

Medium Radius L.E.
 Run No. = 29 , Point No. = 590
 $C_N = 0.488$, $C_m = -0.0818$
 $\alpha = 13.1^\circ$, $M_\infty = 0.399$
 $R_{mac} = 72.7 \times 10^6$

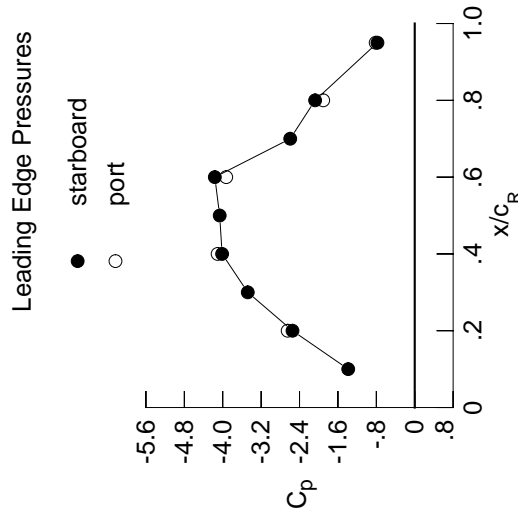

x/c_R	starb'd C_p	port C_p
0.10	-1.3852	*****
0.20	-2.5463	-2.6468
0.30	-3.4781	*****
0.40	-4.0127	-4.1061
0.50	-4.0635	*****
0.60	-4.1648	-3.9269
0.70	-2.5938	*****
0.80	-2.0748	-1.9061
0.90	*****	*****
0.95	-0.7770	-0.8133

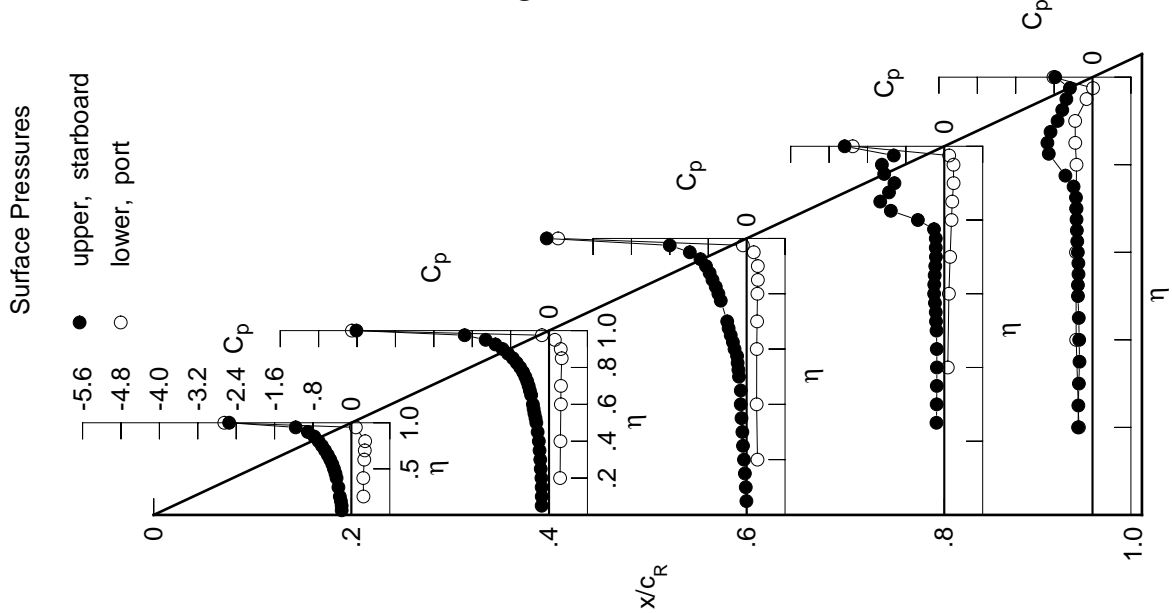
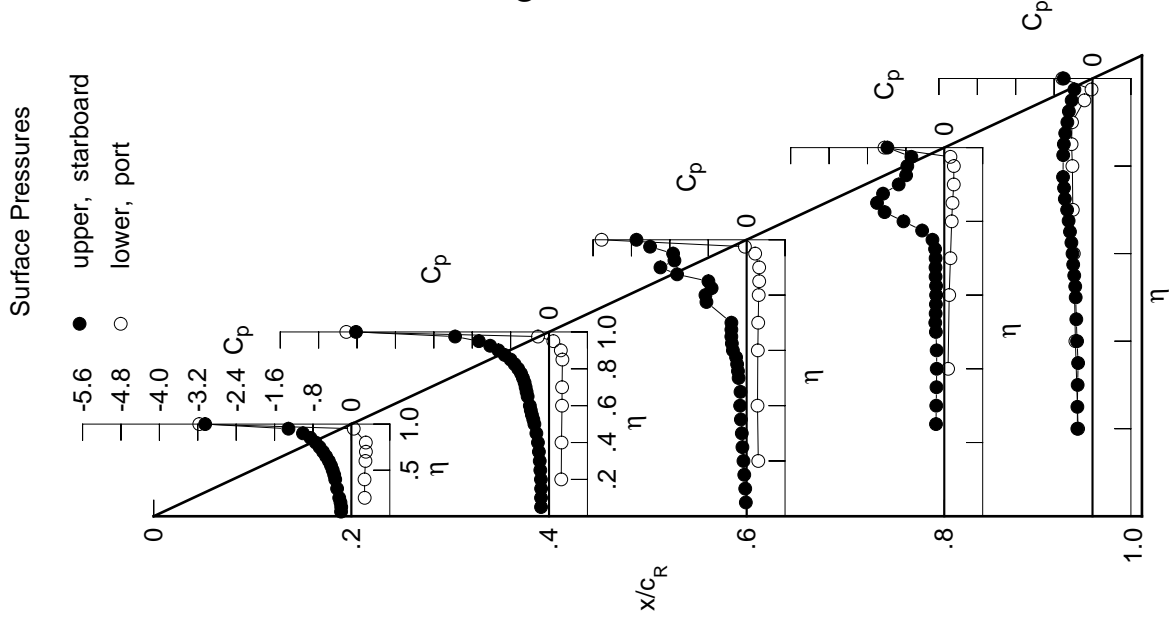
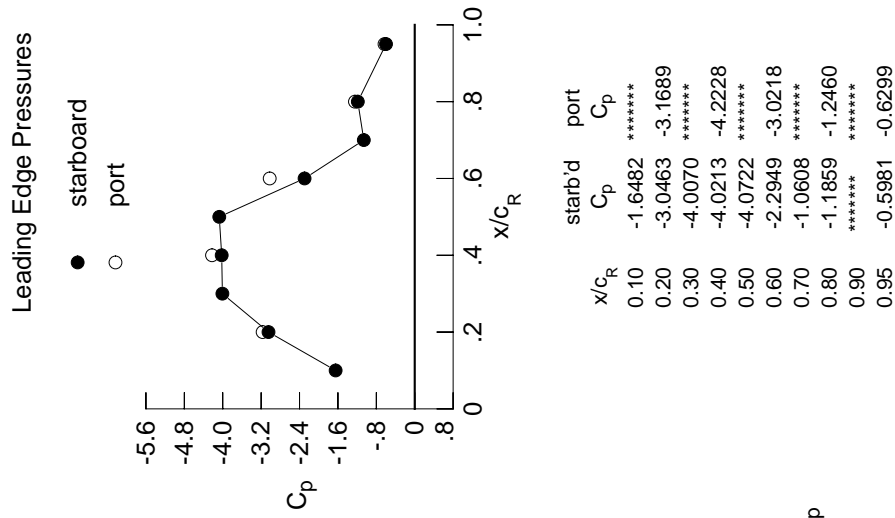

Table C3. Continued.

η	$x/c_R = .2$		$x/c_R = .4$		$x/c_R = .6$		$x/c_R = .8$		$x/c_R = .95$	
	$C_{p,u}$	$C_{p,d}$	$C_{p,u}$	$C_{p,d}$	$C_{p,u}$	$C_{p,d}$	$C_{p,u}$	$C_{p,d}$	$C_{p,u}$	$C_{p,d}$
0.050	-0.2150	-0.1663	-0.0168	*****	*****	*****	*****	*****	*****	*****
0.100	-0.2118	-0.1661	-0.0295	*****	*****	*****	*****	*****	*****	*****
0.150	-0.2270	-0.1646	-0.0495	*****	*****	*****	*****	*****	*****	*****
0.200	-0.2540	-0.1689	-0.0667	*****	*****	*****	*****	*****	*****	*****
0.250	*****	-0.1813	-0.0878	-0.1728	-0.1728	-0.1728	-0.1728	-0.1728	-0.1728	-0.1728
0.300	-0.2972	-0.1937	-0.1008	-0.1675	-0.1675	-0.1675	-0.1675	-0.1675	-0.1675	-0.1675
0.350	*****	-0.2111	-0.1201	-0.1636	-0.1636	-0.1636	-0.1636	-0.1636	-0.1636	-0.1636
0.400	-0.3366	-0.2312	-0.1357	-0.1577	-0.1577	-0.1577	-0.1577	-0.1577	-0.1577	-0.1577
0.450	-0.3583	-0.2642	-0.1283	-0.1589	-0.1589	-0.1589	-0.1589	-0.1589	-0.1589	-0.1589
0.500	-0.3894	-0.3044	-0.1670	-0.1755	-0.1755	-0.1755	-0.1755	-0.1755	-0.1755	-0.1755
0.525	*****	-0.3282	-0.1807	-0.1883	-0.1883	-0.1883	-0.1883	-0.1883	-0.1883	-0.1883
0.550	-0.4246	-0.3564	-0.1981	-0.1796	-0.1796	-0.1796	-0.1796	-0.1796	-0.1796	-0.1796
0.575	*****	-0.3801	-0.2196	-0.1743	-0.1743	-0.1743	-0.1743	-0.1743	-0.1743	-0.1743
0.600	-0.4698	-0.4000	-0.2861	-0.1705	-0.1705	-0.1705	-0.1705	-0.1705	-0.1705	-0.1705
0.625	*****	*****	-0.3082	-0.1714	-0.1714	-0.1714	-0.1714	-0.1714	-0.1714	-0.1714
0.650	-0.5272	-0.4454	-0.3194	-0.1815	-0.1815	-0.1815	-0.1815	-0.1815	-0.1815	-0.1815
0.675	*****	-0.4673	-0.3183	-0.1833	-0.1833	-0.1833	-0.1833	-0.1833	-0.1833	-0.1833
0.700	-0.5910	-0.4874	-0.3180	-0.1811	-0.1811	-0.1811	-0.1811	-0.1811	-0.1811	-0.1811
0.725	*****	-0.5090	*****	-0.1917	-0.1917	-0.1917	-0.1917	-0.1917	-0.1917	-0.1917
0.750	-0.6632	-0.5440	*****	-0.2466	-0.2466	-0.2466	-0.2466	-0.2466	-0.2466	-0.2466
0.775	*****	-0.5840	-0.8373	-0.4612	-0.4612	-0.4612	-0.4612	-0.4612	-0.4612	-0.4612
0.800	-0.7441	-0.6429	-0.8584	-0.8503	-0.8503	-0.8503	-0.8503	-0.8503	-0.8503	-0.8503
0.825	*****	-0.7175	-0.7295	-1.2440	-1.2440	-1.2440	-1.2440	-1.2440	-1.2440	-1.2440
0.850	-0.8519	-0.8017	-0.7967	-1.4016	-1.4016	-1.4016	-1.4016	-1.4016	-1.4016	-1.4016
0.875	*****	-0.9241	-1.4489	-1.2756	-1.2756	-1.2756	-1.2756	-1.2756	-1.2756	-1.2756
0.900	-1.0087	-1.0545	-1.7958	-0.9501	-0.9501	-0.9501	-0.9501	-0.9501	-0.9501	-0.9501
0.925	*****	-1.2262	-1.5042	-0.7949	-0.7949	-0.7949	-0.7949	-0.7949	-0.7949	-0.7949
0.950	-1.3109	-1.4617	-1.5319	-0.7702	-0.7702	-0.7702	-0.7702	-0.7702	-0.7702	-0.7702
0.975	*****	-1.9567	-2.0117	-0.6857	-0.6857	-0.6857	-0.6857	-0.6857	-0.6857	-0.6857
1.000	-3.0463	-4.0213	-2.2949	-1.1859	-1.1859	-1.1859	-1.1859	-1.1859	-1.1859	-1.1859
-0.200	$C_{p,l}$	0.2765	0.2542	0.2425	*****	*****	*****	*****	*****	*****
-0.400		0.2740	0.2598	0.2263	0.0789	0.0789	0.0789	0.0789	0.0789	0.0789
-0.600		0.2931	0.2700	0.2330	0.1023	0.1023	0.1023	0.1023	0.1023	0.1023
-0.700		0.3022	0.2718	0.2407	0.1282	0.1282	0.1282	0.1282	0.1282	0.1282
-0.800		0.3011	*****	0.2509	0.1543	0.1543	0.1543	0.1543	0.1543	0.1543
-0.850		*****	0.2782	0.2615	0.1715	0.1715	0.1715	0.1715	0.1715	0.1715
-0.900		*****	0.2454	0.2610	0.1978	0.1978	0.1978	0.1978	0.1978	0.1978
-0.950		0.0488	0.0894	0.1773	0.1990	0.1990	0.1990	0.1990	0.1990	0.1990
-0.975		*****	-0.2299	-0.0361	0.1280	0.1280	0.1280	0.1280	0.1280	0.1280
-1.000		-3.1689	-4.2228	-3.0218	-1.2460	-1.2460	-1.2460	-1.2460	-1.2460	-1.2460

Medium Radius L.E.
 Run No. = 29, Point No. = 591
 $C_N = 0.520$, $C_m = -0.0783$
 $\alpha = 14.1^\circ$, $M_\infty = 0.399$
 $R_{mac} = 72.5 \times 10^6$



x/c_R	starb'd C_p	port C_p
0.10	-1.6482	*****
0.20	-3.0463	-3.1689
0.30	-4.0070	*****
0.40	-4.0213	-4.2228
0.50	-4.0722	*****
0.60	-2.2949	-3.0218
0.70	-1.0608	*****
0.80	-1.1859	-1.2460
0.90	*****	*****
0.95	-0.5981	-0.6299

Table C3. Continued.

η	$x/c_R = .2$		$x/c_R = .4$		$x/c_R = .6$		$x/c_R = .8$		$x/c_R = .95$	
	$C_{p,u}$	$C_{p,u}$	$C_{p,u}$	$C_{p,u}$	$C_{p,u}$	$C_{p,u}$	$C_{p,u}$	$C_{p,u}$	$C_{p,u}$	$C_{p,u}$
0.050	-0.2550	-0.2242	-0.0605	*****	*****	*****	*****	*****	*****	*****
0.100	-0.2480	-0.2238	-0.0743	*****	*****	*****	*****	*****	*****	*****
0.150	-0.2585	-0.2229	-0.0941	*****	*****	*****	*****	*****	*****	*****
0.200	-0.2847	-0.2239	-0.1123	*****	*****	*****	*****	*****	*****	*****
0.250	*****	-0.2347	-0.1312	-0.1924	-0.3108	*****	*****	*****	*****	*****
0.300	-0.3709	-0.2434	-0.1387	-0.1806	-0.3272	*****	*****	*****	*****	*****
0.350	*****	-0.2547	-0.1660	-0.1753	-0.3305	*****	*****	*****	*****	*****
0.400	-0.4194	-0.2878	-0.1827	-0.1656	-0.3602	*****	*****	*****	*****	*****
0.450	-0.4396	-0.3599	-0.1712	-0.1686	-0.3682	*****	*****	*****	*****	*****
0.500	-0.4684	-0.3877	-0.2301	-0.1666	-0.3942	*****	*****	*****	*****	*****
0.525	*****	-0.3914	-0.2543	-0.1673	-0.4140	*****	*****	*****	*****	*****
0.550	-0.5016	-0.4172	-0.2653	-0.1641	-0.4332	*****	*****	*****	*****	*****
0.575	*****	-0.4724	-0.2632	-0.1671	-0.4799	*****	*****	*****	*****	*****
0.600	-0.5467	-0.5378	-0.2895	-0.1773	-0.5062	*****	*****	*****	*****	*****
0.625	*****	*****	-0.2783	-0.2017	-0.5505	*****	*****	*****	*****	*****
0.650	-0.6103	-0.6289	-0.2949	-0.2653	-0.5964	*****	*****	*****	*****	*****
0.675	*****	-0.6779	-0.3287	-0.3978	-0.6313	*****	*****	*****	*****	*****
0.700	-0.6867	-0.6899	-0.3875	-0.5998	-0.6568	*****	*****	*****	*****	*****
0.725	*****	-0.6998	*****	-0.8557	-0.6882	*****	*****	*****	*****	*****
0.750	-0.7777	-0.7668	*****	-1.0654	-0.6809	*****	*****	*****	*****	*****
0.775	*****	-0.8642	-1.3023	-1.2048	-0.6869	*****	*****	*****	*****	*****
0.800	-0.8829	-0.9114	-1.7440	-1.1808	*****	*****	*****	*****	*****	*****
0.825	*****	-1.0142	-1.9812	-1.0410	-0.6104	*****	*****	*****	*****	*****
0.850	-1.0273	-1.3516	-1.8820	-0.7981	-0.5553	*****	*****	*****	*****	*****
0.875	*****	-1.8143	-1.6008	-0.6805	-0.5102	*****	*****	*****	*****	*****
0.900	-1.2365	-2.1009	-1.3892	-0.6723	-0.4781	*****	*****	*****	*****	*****
0.925	*****	-2.2602	-1.3366	-0.6474	-0.4823	*****	*****	*****	*****	*****
0.950	-1.6460	-2.2959	-1.2446	-0.5967	-0.3959	*****	*****	*****	*****	*****
0.975	*****	-2.0867	-1.1558	-0.5540	-0.3404	*****	*****	*****	*****	*****
1.000	-4.2388	-3.0940	-1.4839	-0.8647	-0.5322	*****	*****	*****	*****	*****
-0.200	$C_{p,l}$	$C_{p,l}$	$C_{p,l}$	$C_{p,l}$	$C_{p,l}$	$C_{p,l}$	$C_{p,l}$	$C_{p,l}$	$C_{p,l}$	$C_{p,l}$
-0.400	0.3248	0.2982	0.2742	*****	*****	*****	*****	*****	*****	*****
-0.600	0.3235	0.3045	0.2587	0.0998	-0.3602	*****	*****	*****	*****	*****
-0.700	0.3401	0.3153	0.2633	0.1221	-0.4302	*****	*****	*****	*****	*****
-0.800	0.3393	0.3194	0.2721	0.1467	-0.4642	*****	*****	*****	*****	*****
-0.850	0.3175	*****	0.2784	0.1713	-0.4497	*****	*****	*****	*****	*****
-0.900	*****	0.3108	0.2835	0.1880	-0.4481	*****	*****	*****	*****	*****
-0.950	0.0660	0.0654	0.1733	0.1984	-0.1449	*****	*****	*****	*****	*****
-0.975	*****	-0.2895	-0.0337	0.1099	-0.0044	*****	*****	*****	*****	*****
-1.000	-4.2103	-3.4009	-1.7341	-0.9828	-0.5539	*****	*****	*****	*****	*****

Medium Radius L.E.
 Run No. = 29 , Point No. = 592
 $C_N = 0.628$, $C_m = -0.0897$
 $\alpha = 16.2^\circ$, $M_\infty = 0.399$
 $R_{mac} = 72.7 \times 10^6$

Leading Edge Pressures

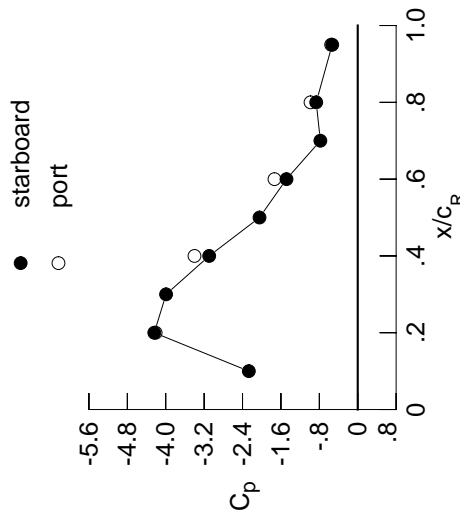

x/c_R	starb'd C_p	port C_p
0.10	-2.2687	*****
0.20	-4.2388	-4.2103
0.30	-3.9929	*****
0.40	-3.0940	-3.4009
0.50	-2.0467	*****
0.60	-1.4839	-1.7341
0.70	-0.7788	*****
0.80	-0.8647	-0.9828
0.90	*****	*****
0.95	-0.5322	-0.5539

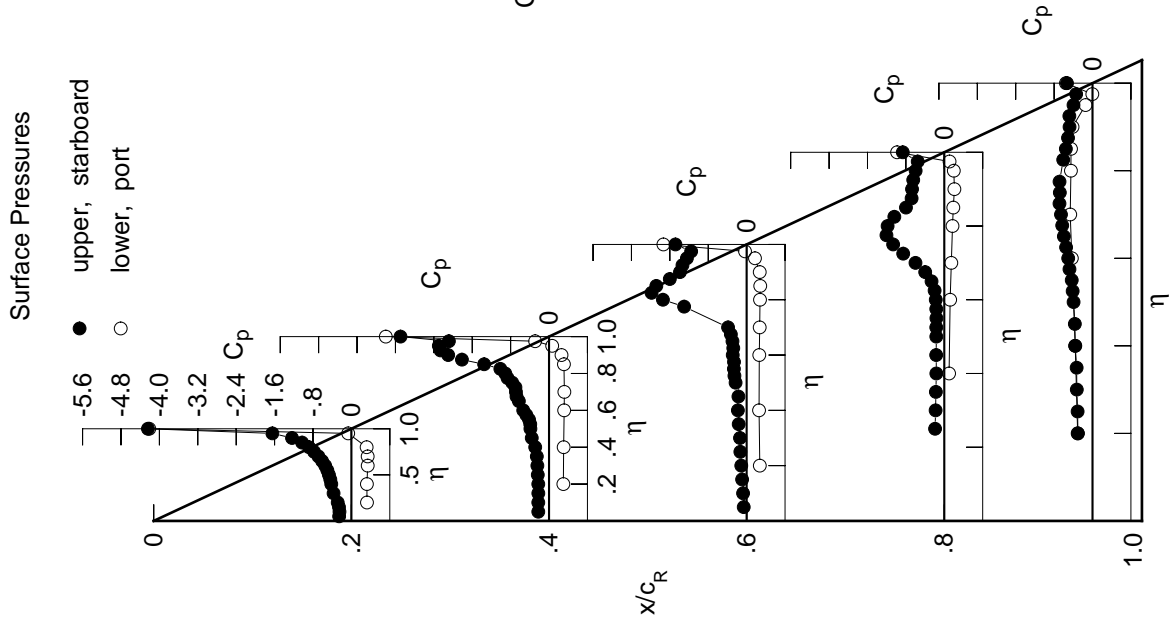
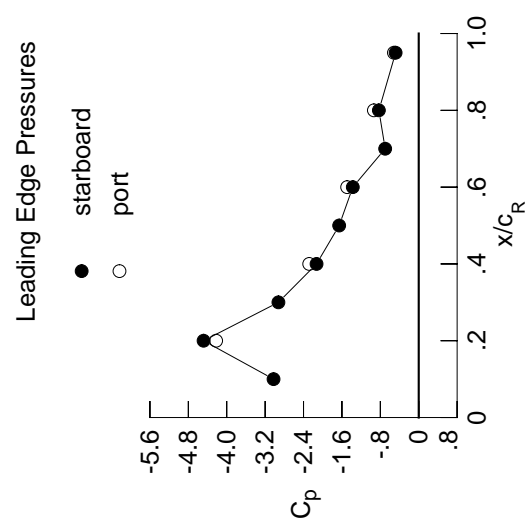

Table C3. Continued.

η	$x/c_R = .2$		$x/c_R = .4$		$x/c_R = .6$		$x/c_R = .8$		$x/c_R = .95$	
	$C_{p,u}$	$C_{p,u}$	$C_{p,u}$	$C_{p,u}$	$C_{p,u}$	$C_{p,u}$	$C_{p,u}$	$C_{p,u}$	$C_{p,u}$	$C_{p,u}$
0.050	-0.3147	-0.2930	-0.0927	*****	*****	*****	*****	*****	*****	*****
0.100	-0.3047	-0.2959	-0.1091	*****	*****	*****	*****	*****	*****	*****
0.150	-0.3131	-0.2943	-0.1269	*****	*****	*****	*****	*****	*****	*****
0.200	-0.3288	-0.2954	-0.1430	*****	*****	*****	*****	*****	*****	-0.2923
0.250	*****	-0.3016	-0.1583	-0.2151	-0.3123	*****	*****	*****	*****	-0.3123
0.300	-0.4476	-0.3069	-0.1725	-0.1988	-0.3495	*****	*****	*****	*****	-0.3495
0.350	*****	-0.3357	-0.2340	-0.2119	-0.3588	*****	*****	*****	*****	-0.3588
0.400	-0.5555	-0.4187	-0.2564	-0.2205	-0.3878	*****	*****	*****	*****	-0.3878
0.450	-0.5752	-0.5215	-0.2150	-0.2083	-0.4034	*****	*****	*****	*****	-0.4034
0.500	-0.6067	-0.4114	-0.2449	-0.2070	-0.4615	*****	*****	*****	*****	-0.4615
0.525	*****	-0.4035	-0.2516	-0.2239	-0.4989	*****	*****	*****	*****	-0.4989
0.550	-0.6375	-0.4153	-0.2625	-0.2519	-0.5316	*****	*****	*****	*****	-0.5316
0.575	*****	-0.4141	-0.2701	-0.3054	-0.5967	*****	*****	*****	*****	-0.5967
0.600	-0.6745	-0.4184	-0.3450	-0.3906	-0.6312	*****	*****	*****	*****	-0.6312
0.625	*****	*****	-0.3969	-0.5109	-0.6738	*****	*****	*****	*****	-0.6738
0.650	-0.7446	-0.4199	-0.5575	-0.6615	-0.7055	*****	*****	*****	*****	-0.7055
0.675	*****	-0.4445	-0.7885	-0.8404	-0.7198	*****	*****	*****	*****	-0.7198
0.700	-0.8444	-0.5197	-1.0726	-1.0011	-0.7294	*****	*****	*****	*****	-0.7294
0.725	*****	-0.7405	*****	-1.1175	-0.7405	*****	*****	*****	*****	-0.7405
0.750	-0.9654	-1.2698	*****	-1.1339	-0.7170	*****	*****	*****	*****	-0.7170
0.775	*****	-1.9241	-1.9595	-1.0853	-0.6928	*****	*****	*****	*****	-0.6928
0.800	-1.0901	-2.4192	-1.8451	-0.9233	*****	*****	*****	*****	*****	-0.9233
0.825	*****	-2.6046	-1.4897	-0.7531	-0.5902	*****	*****	*****	*****	-0.5902
0.850	-1.2547	-2.5577	-1.2497	-0.6732	-0.5358	*****	*****	*****	*****	-0.5358
0.875	*****	-2.2987	-1.2550	-0.6568	-0.4978	*****	*****	*****	*****	-0.4978
0.900	-1.5024	-2.0272	-1.2530	-0.6559	-0.4632	*****	*****	*****	*****	-0.4632
0.925	*****	-1.8925	-1.2282	-0.6338	-0.4610	*****	*****	*****	*****	-0.4610
0.950	-2.2072	-1.7698	-1.1933	-0.5959	-0.3708	*****	*****	*****	*****	-0.3708
0.975	*****	-1.6585	-1.1357	-0.5741	-0.3104	*****	*****	*****	*****	-0.3104
1.000	-4.4828	-2.1290	-1.3733	-0.8300	-0.4813	*****	*****	*****	*****	-0.4813
-0.200	$C_{p,l}$	$C_{p,l}$	$C_{p,l}$	$C_{p,l}$	$C_{p,l}$	$C_{p,l}$	$C_{p,l}$	$C_{p,l}$	$C_{p,l}$	$C_{p,l}$
-0.400	0.3806	0.3452	0.3083	*****	-0.3287	*****	*****	*****	*****	-0.3287
-0.600	0.3795	0.3506	0.2938	0.1227	-0.3834	*****	*****	*****	*****	-0.3834
-0.700	0.3896	0.3598	0.2976	0.1444	-0.4660	*****	*****	*****	*****	-0.4660
-0.800	0.3775	0.3598	0.3055	0.1677	-0.4905	*****	*****	*****	*****	-0.4905
-0.850	0.3321	*****	0.3090	0.1918	-0.4522	*****	*****	*****	*****	-0.4522
-0.900	*****	0.3319	0.3089	0.2067	-0.4383	*****	*****	*****	*****	-0.4383
-0.950	*****	0.2641	0.2873	0.2230	-0.3929	*****	*****	*****	*****	-0.3929
-0.975	-0.1980	0.0442	0.1596	0.1906	-0.1184	*****	*****	*****	*****	-0.1184
-1.000	*****	-0.3213	-0.0741	0.0777	0.0053	*****	*****	*****	*****	0.0053
	-4.2205	-2.2819	-1.4911	-0.9347	-0.5165	*****	*****	*****	*****	-0.5165

Medium Radius L.E.
 Run No. = 29 , Point No. = 593
 $C_N = 0.737$, $C_m = -0.0995$
 $\alpha = 18.2^\circ$, $M_\infty = 0.399$
 $R_{mac} = 72.6 \times 10^6$



x/c_R	starb'd C_p	port C_p
0.10	-3.0246	*****
0.20	-4.4828	-4.2205
0.30	-2.9229	*****
0.40	-2.1290	-2.2819
0.50	-1.6576	*****
0.60	-1.3733	-1.4911
0.70	-0.6988	*****
0.80	-0.8300	-0.9347
0.90	*****	*****
0.95	-0.4813	-0.5165

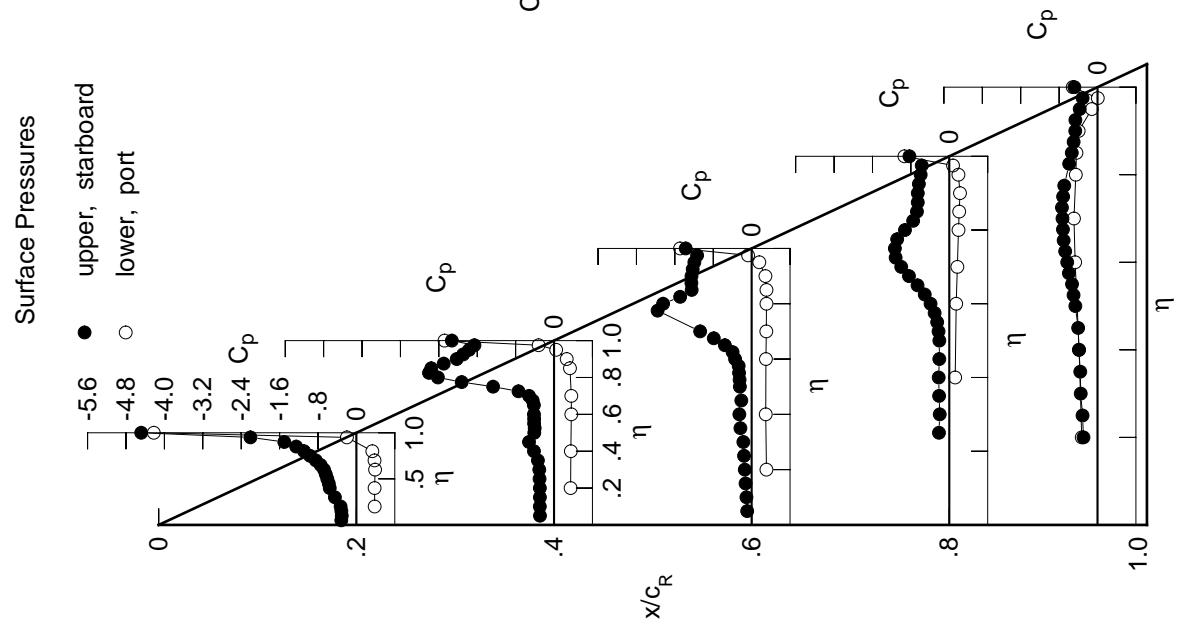
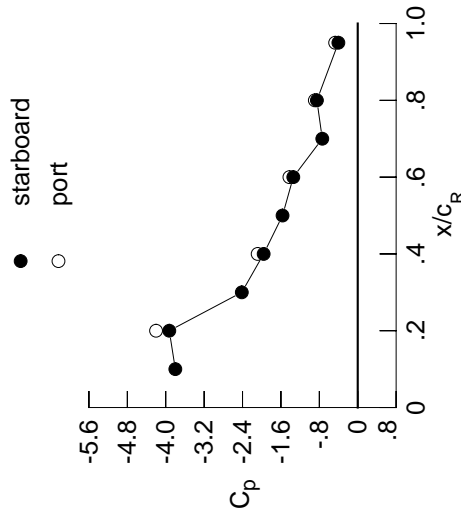

Table C3. Continued.

η	$x/c_R = .2$		$x/c_R = .4$		$x/c_R = .6$		$x/c_R = .8$		$x/c_R = .95$	
	$C_{p,u}$	$C_{p,u}$	$C_{p,u}$	$C_{p,u}$	$C_{p,u}$	$C_{p,u}$	$C_{p,u}$	$C_{p,u}$	$C_{p,u}$	$C_{p,u}$
0.050	-0.3938	-0.3652	-0.1298	*****	*****	*****	*****	*****	*****	*****
0.100	-0.3831	-0.3649	-0.1459	*****	*****	*****	*****	*****	*****	*****
0.150	-0.3946	-0.3646	-0.1640	*****	*****	*****	*****	*****	*****	*****
0.200	-0.3997	-0.3618	-0.1768	*****	*****	*****	*****	*****	*****	-0.2980
0.250	*****	-0.3659	-0.1946	-0.2513	-0.3095	*****	*****	*****	*****	*****
0.300	-0.5207	-0.3969	-0.2163	-0.2393	-0.3526	*****	*****	*****	*****	*****
0.350	*****	-0.4945	-0.2728	-0.2432	-0.3776	*****	*****	*****	*****	*****
0.400	-0.6635	-0.4805	-0.2838	-0.2566	-0.4214	*****	*****	*****	*****	*****
0.450	-0.6778	-0.4516	-0.2653	-0.2929	-0.4567	*****	*****	*****	*****	*****
0.500	-0.7781	-0.4573	-0.3215	-0.3592	-0.5282	*****	*****	*****	*****	*****
0.525	*****	-0.4685	-0.3584	-0.4139	-0.5752	*****	*****	*****	*****	*****
0.550	-0.9241	-0.4868	-0.4142	-0.4921	-0.6202	*****	*****	*****	*****	*****
0.575	*****	-0.5009	-0.4870	-0.6024	-0.6949	*****	*****	*****	*****	*****
0.600	-0.8393	-0.5360	-0.6712	-0.7394	-0.7428	*****	*****	*****	*****	*****
0.625	*****	*****	-0.8241	-0.8926	-0.7912	*****	*****	*****	*****	*****
0.650	-0.7911	-0.7765	-1.1160	-1.0369	-0.8207	*****	*****	*****	*****	*****
0.675	*****	-1.0764	-1.4480	-1.1677	-0.8274	*****	*****	*****	*****	*****
0.700	-0.8191	-1.5289	-1.7205	-1.2523	-0.8206	*****	*****	*****	*****	*****
0.725	*****	-2.0444	*****	-1.2751	-0.7953	*****	*****	*****	*****	*****
0.750	-0.8804	-2.5497	*****	-1.2049	-0.7162	*****	*****	*****	*****	*****
0.775	*****	-2.8299	-1.8473	-1.0647	-0.6196	*****	*****	*****	*****	*****
0.800	-1.0958	-2.8254	-1.4529	-0.8616	*****	*****	*****	*****	*****	*****
0.825	*****	-2.4390	-1.2790	-0.7525	-0.4655	*****	*****	*****	*****	*****
0.850	-2.5930	-2.0838	-1.2598	-0.7333	-0.4435	*****	*****	*****	*****	*****
0.875	*****	-1.9953	-1.2784	-0.7286	-0.4097	*****	*****	*****	*****	*****
0.900	-3.3219	-1.9599	-1.2620	-0.7247	-0.3772	*****	*****	*****	*****	*****
0.925	*****	-1.8415	-1.2234	-0.6956	-0.3885	*****	*****	*****	*****	*****
0.950	-2.9020	-1.7445	-1.1976	-0.6697	-0.3197	*****	*****	*****	*****	*****
0.975	*****	-1.6725	-1.1538	-0.6551	-0.2646	*****	*****	*****	*****	*****
1.000	-3.9260	-1.9602	-1.3427	-0.8504	-0.4029	*****	*****	*****	*****	*****
-0.200	$C_{p,l}$	$C_{p,l}$	$C_{p,l}$	$C_{p,l}$	$C_{p,l}$	$C_{p,l}$	$C_{p,l}$	$C_{p,l}$	$C_{p,l}$	$C_{p,l}$
-0.400	0.4376	0.3910	0.3444	*****	*****	*****	*****	*****	*****	-0.3197
-0.600	0.4339	0.3946	0.3298	0.1513	-0.3867	*****	*****	*****	*****	*****
-0.700	0.4384	0.3996	0.3341	0.1734	-0.4786	*****	*****	*****	*****	*****
-0.800	0.4148	0.3957	0.3386	0.1961	-0.4991	*****	*****	*****	*****	*****
-0.850	0.3489	*****	0.3362	0.2183	-0.4467	*****	*****	*****	*****	*****
-0.900	*****	0.3426	0.3286	0.2299	-0.4210	*****	*****	*****	*****	*****
-0.950	*****	0.2510	0.2899	0.2385	-0.3625	*****	*****	*****	*****	*****
-0.975	-0.2760	-0.0108	0.1257	0.1810	-0.0898	*****	*****	*****	*****	*****
-1.000	*****	-0.4163	-0.1482	0.0368	0.0125	*****	*****	*****	*****	*****
	-4.2017	-2.0845	-1.4232	-0.8933	-0.4702	*****	*****	*****	*****	*****

Medium Radius L.E.
 Run No. = 29 , Point No. = 594
 $C_N = 0.856$, $C_m = -0.1137$
 $\alpha = 20.3^\circ$, $M_\infty = 0.400$
 $R_{mac} = 72.6 \times 10^6$

Leading Edge Pressures



x/c_R	starb'd C_p	port C_p
0.10	-3.8001	*****
0.20	-3.9260	-4.2017
0.30	-2.4154	*****
0.40	-1.9602	-2.0845
0.50	-1.5667	*****
0.60	-1.3427	-1.4232
0.70	-0.7386	*****
0.80	-0.8504	-0.8933
0.90	*****	*****
0.95	-0.4029	-0.4702

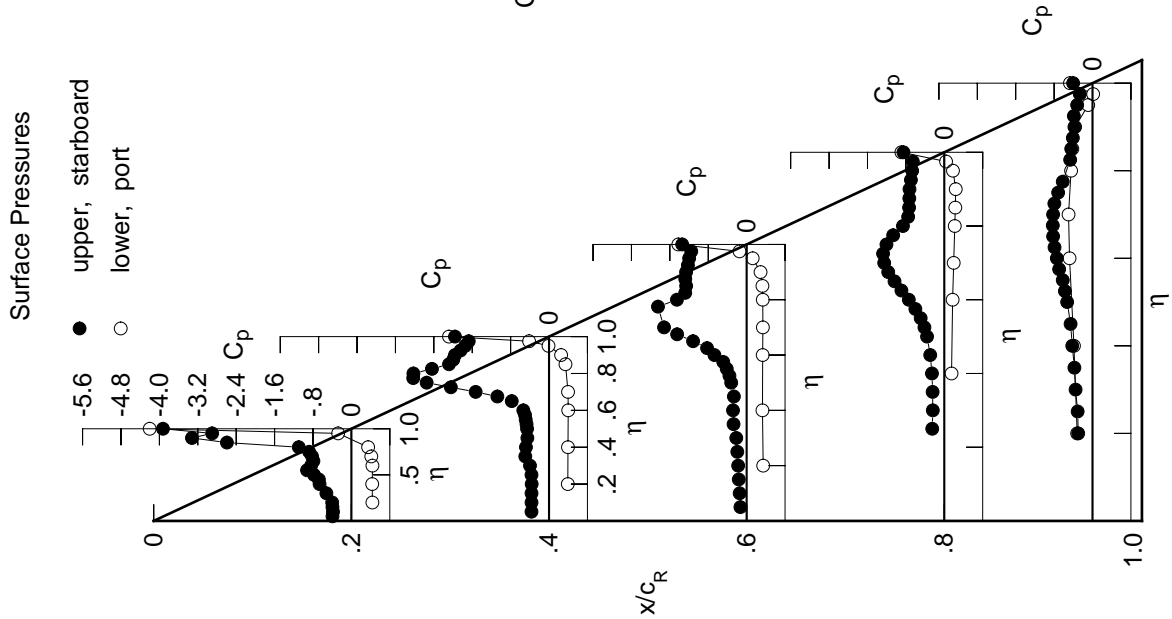
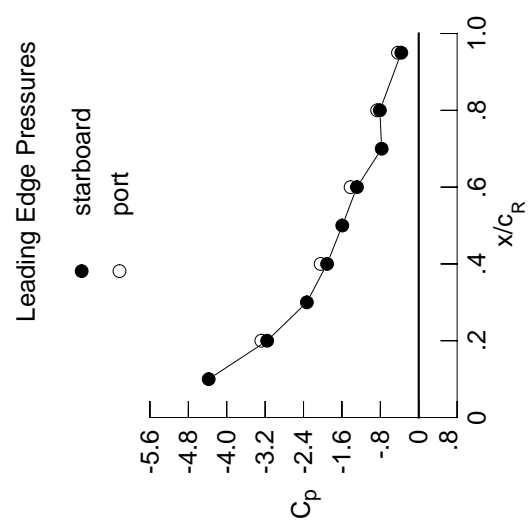

Table C3. Continued.

η	$x/c_R = .2$		$x/c_R = .4$		$x/c_R = .6$		$x/c_R = .8$		$x/c_R = .95$	
	$C_{p,u}$	$C_{p,u}$	$C_{p,u}$	$C_{p,u}$	$C_{p,u}$	$C_{p,u}$	$C_{p,u}$	$C_{p,u}$	$C_{p,u}$	$C_{p,u}$
0.050	-0.4926	-0.4369	-0.1679	*****	*****	*****	*****	*****	*****	
0.100	-0.4820	-0.4314	-0.1827	*****	*****	*****	*****	*****	*****	
0.150	-0.4941	-0.4343	-0.2013	*****	*****	*****	*****	*****	*****	
0.200	-0.5045	-0.4256	-0.2148	*****	*****	*****	*****	*****	-0.3507	
0.250	*****	-0.4595	-0.2385	-0.2929	-0.3495	*****	*****	*****	*****	
0.300	-0.6176	-0.5366	-0.2663	-0.2886	-0.3725	*****	*****	*****	*****	
0.350	*****	-0.5042	-0.3191	-0.3019	-0.3961	*****	*****	*****	*****	
0.400	-0.8472	-0.4966	-0.3379	-0.3306	-0.4551	*****	*****	*****	*****	
0.450	-0.7279	-0.5113	-0.3482	-0.4025	-0.5136	*****	*****	*****	*****	
0.500	-0.6975	-0.5347	-0.4791	-0.5305	-0.6171	*****	*****	*****	*****	
0.525	*****	-0.5735	-0.5770	-0.6250	-0.6769	*****	*****	*****	*****	
0.550	-0.7009	-0.6301	-0.7065	-0.7394	-0.7303	*****	*****	*****	*****	
0.575	*****	-0.7068	-0.8763	-0.8755	-0.8073	*****	*****	*****	*****	
0.600	-0.7040	-0.8497	-1.1645	-1.0180	-0.8523	*****	*****	*****	*****	
0.625	*****	*****	-1.3949	-1.1594	-0.8909	*****	*****	*****	*****	
0.650	-0.6553	-1.4566	-1.7214	-1.2646	-0.9059	*****	*****	*****	*****	
0.675	*****	-1.9638	-2.0011	-1.3421	-0.8888	*****	*****	*****	*****	
0.700	-0.8202	-2.4983	-2.1085	-1.3696	-0.8543	*****	*****	*****	*****	
0.725	*****	-2.9480	*****	-1.3419	-0.7969	*****	*****	*****	*****	
0.750	-2.6179	-3.1893	*****	-1.2185	-0.6829	*****	*****	*****	*****	
0.775	*****	-2.9355	-1.6042	-1.0522	-0.5604	*****	*****	*****	*****	
0.800	-3.5563	-2.3181	-1.3382	-0.8657	*****	*****	*****	*****	*****	
0.825	*****	-2.0208	-1.2907	-0.7898	-0.4318	*****	*****	*****	*****	
0.850	-3.4781	-1.9945	-1.2774	-0.7705	-0.4265	*****	*****	*****	*****	
0.875	*****	-2.0055	-1.2886	-0.7646	-0.4005	*****	*****	*****	*****	
0.900	-3.0131	-1.9737	-1.2768	-0.7662	-0.3629	*****	*****	*****	*****	
0.925	*****	-1.8361	-1.2196	-0.7413	-0.3710	*****	*****	*****	*****	
0.950	-2.6002	-1.7574	-1.1769	-0.7095	-0.3174	*****	*****	*****	*****	
0.975	*****	-1.7165	-1.1508	-0.6921	-0.2618	*****	*****	*****	*****	
1.000	-3.1580	-1.9099	-1.2870	-0.8099	-0.3634	*****	*****	*****	*****	
-0.200	$C_{p,l}$	0.4339	0.3781	*****	-0.2976	*****	*****	*****	*****	
-0.400	0.4830	0.4365	0.3661	0.1831	-0.3746	*****	*****	*****	*****	
-0.600	0.4777	0.4380	0.3684	0.2049	-0.4595	*****	*****	*****	*****	
-0.700	0.4439	0.4281	0.3710	0.2268	-0.4747	*****	*****	*****	*****	
-0.800	0.3558	*****	0.3604	0.2475	-0.4175	*****	*****	*****	*****	
-0.850	*****	0.3450	0.3440	0.2562	-0.3899	*****	*****	*****	*****	
-0.900	*****	0.2277	0.2856	0.2555	-0.3241	*****	*****	*****	*****	
-0.950	-0.3481	-0.0828	0.0773	0.1708	-0.0625	*****	*****	*****	*****	
-0.975	*****	-0.5374	-0.2457	-0.0062	0.0173	*****	*****	*****	*****	
-1.000	-3.2789	-2.0439	-1.4193	-0.8653	-0.4320	*****	*****	*****	*****	

Medium Radius L.E.
 Run No. = 29 , Point No. = 595
 $C_N = 0.987$, $C_m = -0.1282$
 $\alpha = 22.4^\circ$, $M_\infty = 0.399$
 $R_{mac} = 72.6 \times 10^6$



x/c_R	starb'd C_p	port C_p
0.10	-4.3757	*****
0.20	-3.1580	-3.2789
0.30	-2.3316	*****
0.40	-1.9099	-2.0439
0.50	-1.5926	*****
0.60	-1.2870	-1.4193
0.70	-0.7718	*****
0.80	-0.8099	-0.8653
0.90	*****	*****
0.95	-0.3634	-0.4320

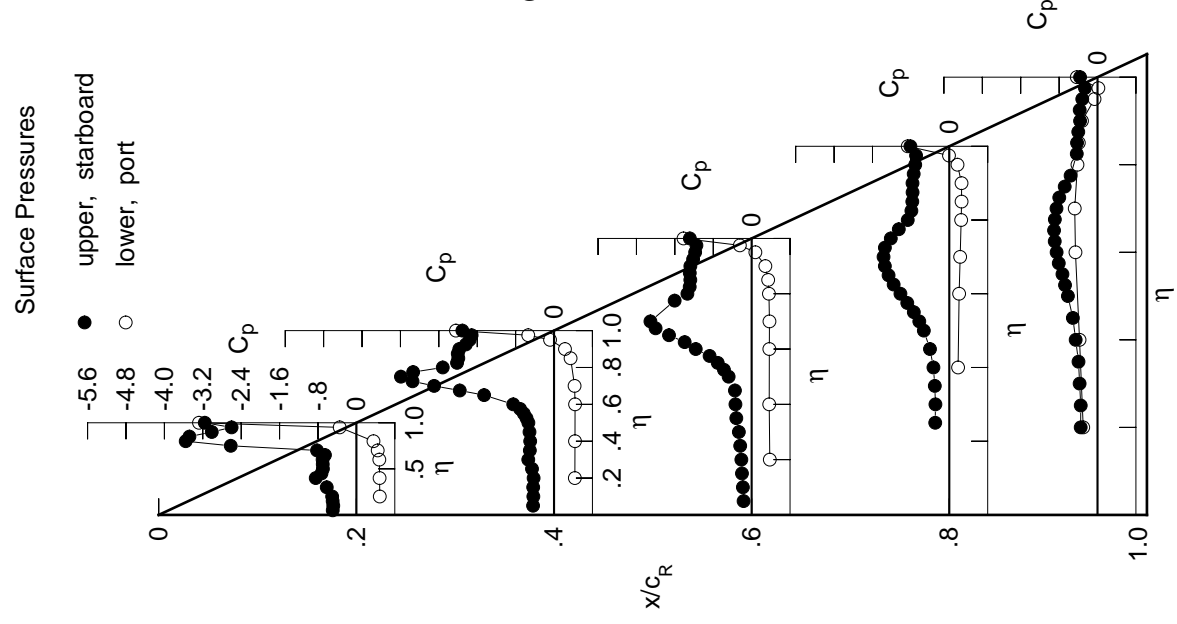
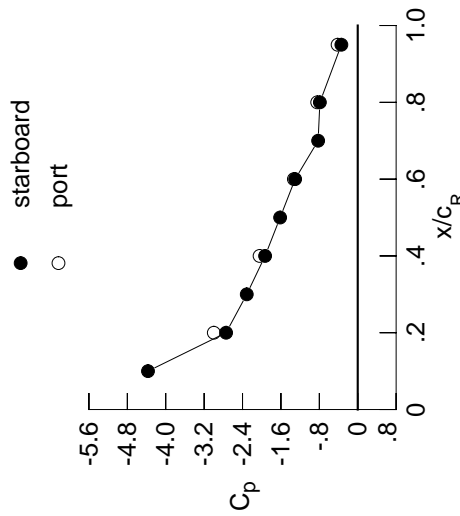

Table C3. Continued.

η	$x/c_R = .2$		$x/c_R = .4$		$x/c_R = .6$		$x/c_R = .8$		$x/c_R = .95$	
	$C_{p,u}$	$C_{p,u}$	$C_{p,u}$	$C_{p,u}$	$C_{p,u}$	$C_{p,u}$	$C_{p,u}$	$C_{p,u}$	$C_{p,u}$	$C_{p,u}$
0.050	-0.5978	-0.5059	-0.2035	*****	*****	*****	*****	*****	*****	*****
0.100	-0.5913	-0.5038	-0.2216	*****	*****	*****	*****	*****	*****	*****
0.150	-0.5932	-0.4986	-0.2407	*****	*****	*****	*****	*****	*****	*****
0.200	-0.6298	-0.4949	-0.2598	*****	*****	*****	*****	*****	*****	-0.3687
0.250	*****	-0.5693	-0.2863	-0.3342	-0.3803	*****	*****	*****	*****	-0.3803
0.300	-0.8061	-0.5730	-0.3082	-0.3366	-0.3939	*****	*****	*****	*****	-0.3939
0.350	*****	-0.5685	-0.3615	-0.3638	-0.4166	*****	*****	*****	*****	-0.4166
0.400	-0.7182	-0.5832	-0.4417	-0.4079	-0.4826	*****	*****	*****	*****	-0.4826
0.450	-0.7275	-0.6270	-0.5093	-0.5100	-0.5577	*****	*****	*****	*****	-0.5577
0.500	-0.7479	-0.7156	-0.7037	-0.6800	-0.6808	*****	*****	*****	*****	-0.6808
0.525	*****	-0.8173	-0.8583	-0.7988	-0.7449	*****	*****	*****	*****	-0.7449
0.550	-0.7381	-0.9542	-1.0494	-0.9307	-0.8033	*****	*****	*****	*****	-0.8033
0.575	*****	-1.1397	-1.2803	-1.0857	-0.8764	*****	*****	*****	*****	-0.8764
0.600	-0.7298	-1.4201	-1.6040	-1.2338	-0.9172	*****	*****	*****	*****	-0.9172
0.625	*****	*****	-1.8420	-1.3744	-0.9444	*****	*****	*****	*****	-0.9444
0.650	-1.0787	-2.2644	-2.1159	-1.4666	-0.9440	*****	*****	*****	*****	-0.9440
0.675	*****	-2.8145	-2.2894	-1.5213	-0.9034	*****	*****	*****	*****	-0.9034
0.700	-2.4309	-3.2192	-2.2421	-1.5199	-0.8383	*****	*****	*****	*****	-0.8383
0.725	*****	-3.3177	*****	-1.4548	-0.7463	*****	*****	*****	*****	-0.7463
0.750	-3.8922	-3.0279	*****	-1.3026	-0.5931	*****	*****	*****	*****	-0.5931
0.775	*****	-2.4024	-1.4905	-1.1053	-0.4610	*****	*****	*****	*****	-0.4610
0.800	-4.0918	-2.0743	-1.3495	-0.9165	*****	*****	*****	*****	*****	-0.9165
0.825	*****	-2.0360	-1.3278	-0.8433	-0.4061	*****	*****	*****	*****	-0.4061
0.850	-3.3645	-2.0399	-1.3116	-0.8257	-0.4176	*****	*****	*****	*****	-0.4176
0.875	*****	-2.0604	-1.3210	-0.8113	-0.3978	*****	*****	*****	*****	-0.3978
0.900	-2.8545	-2.0140	-1.3121	-0.8015	-0.3627	*****	*****	*****	*****	-0.3627
0.925	*****	-1.8991	-1.2671	-0.7792	-0.3672	*****	*****	*****	*****	-0.3672
0.950	-2.5054	-1.8463	-1.2271	-0.7434	-0.3334	*****	*****	*****	*****	-0.3334
0.975	*****	-1.8216	-1.2109	-0.7228	-0.2749	*****	*****	*****	*****	-0.2749
1.000	-2.7427	-1.9296	-1.3041	-0.7886	-0.3408	*****	*****	*****	*****	-0.3408
-0.200	$C_{p,l}$	$C_{p,l}$	$C_{p,l}$	$C_{p,l}$	$C_{p,l}$	$C_{p,l}$	$C_{p,l}$	$C_{p,l}$	$C_{p,l}$	$C_{p,l}$
-0.400	0.5391	0.4786	0.4187	*****	*****	*****	*****	*****	*****	-0.2855
-0.600	0.5315	0.4797	0.4038	0.2137	-0.3841	*****	*****	*****	*****	-0.3841
-0.700	0.5160	0.4761	0.4051	0.2332	-0.4694	*****	*****	*****	*****	-0.4694
-0.800	0.4685	0.4604	0.4033	0.2570	-0.4730	*****	*****	*****	*****	-0.4730
-0.850	0.3560	*****	0.3871	0.2712	-0.4032	*****	*****	*****	*****	-0.4032
-0.900	*****	0.3462	0.3606	0.2765	-0.3697	*****	*****	*****	*****	-0.3697
-0.950	*****	0.2024	0.2851	0.2655	-0.2975	*****	*****	*****	*****	-0.2975
-0.975	-0.4411	-0.1586	0.0417	0.1553	-0.0435	*****	*****	*****	*****	-0.0435
-1.000	-2.9987	-2.0447	-1.3300	-0.8444	-0.4192	*****	*****	*****	*****	-0.4192

Medium Radius L.E.
 Run No. = 29 , Point No. = 596
 $C_N = 1.101$, $C_m = -0.1397$
 $\alpha = 24.4^\circ$, $M_\infty = 0.399$
 $R_{mac} = 72.6 \times 10^6$

Leading Edge Pressures



x/c_R	starb'd C_p	port C_p
0.10	-4.3695	*****
0.20	-2.7427	-2.9987
0.30	-2.3117	*****
0.40	-1.9296	-2.0447
0.50	-1.6166	*****
0.60	-1.3041	-1.3300
0.70	-0.8252	*****
0.80	-0.7886	-0.8444
0.90	*****	*****
0.95	-0.3408	-0.4192

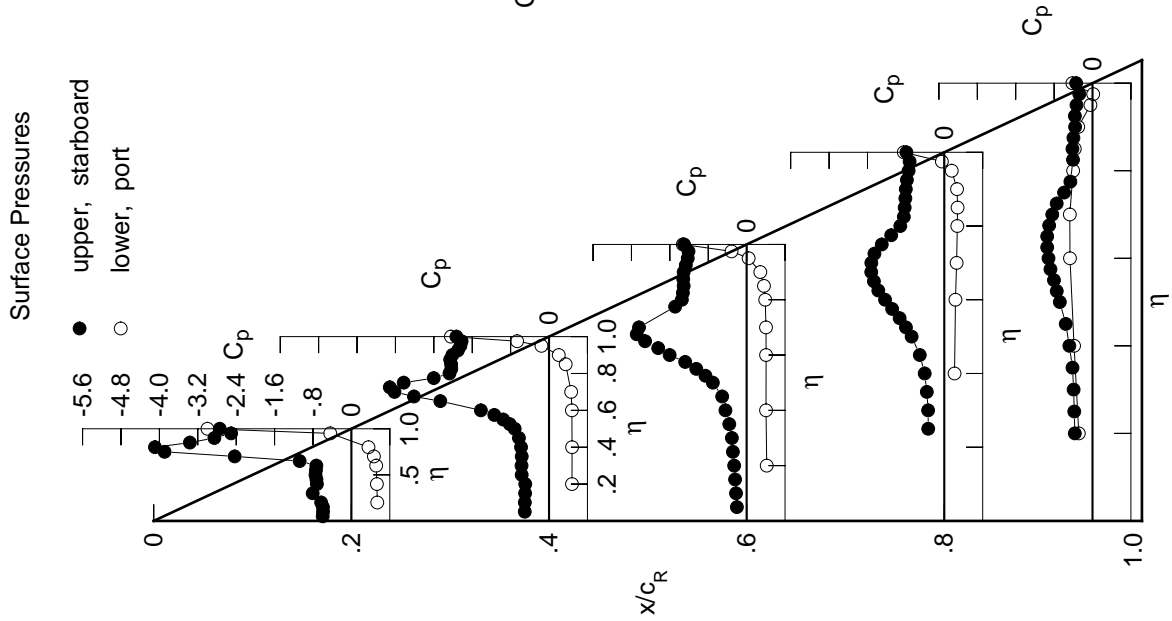
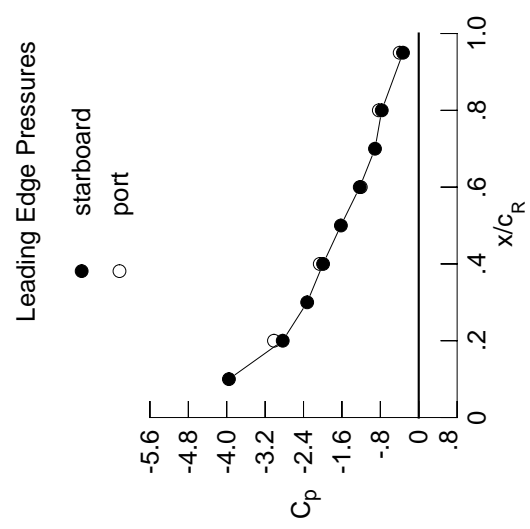

Table C3. Concluded.

η	$x/c_R = .2$		$x/c_R = .4$		$x/c_R = .6$		$x/c_R = .8$		$x/c_R = .95$	
	$C_{p,u}$	$C_{p,u}$	$C_{p,u}$	$C_{p,u}$	$C_{p,u}$	$C_{p,u}$	$C_{p,u}$	$C_{p,u}$	$C_{p,l}$	$C_{p,l}$
0.050	-0.7008	-0.5752	-0.2385	*****	*****	*****	*****	*****	*****	*****
0.100	-0.6991	-0.5742	-0.2560	*****	*****	*****	*****	*****	*****	*****
0.150	-0.7193	-0.5737	-0.2786	*****	*****	*****	*****	*****	*****	*****
0.200	-0.7825	-0.5672	-0.3030	*****	*****	*****	*****	*****	-0.3823	*****
0.250	*****	-0.6014	-0.3347	-0.4012	-0.4157	*****	*****	*****	-0.4157	*****
0.300	-0.8092	-0.6676	-0.3712	-0.4160	-0.4397	*****	*****	*****	-0.4397	*****
0.350	*****	-0.6788	-0.4248	-0.4712	-0.4658	*****	*****	*****	-0.4658	*****
0.400	-0.8264	-0.7126	-0.5115	-0.5448	-0.5362	*****	*****	*****	-0.5362	*****
0.450	-0.8438	-0.8178	-0.6408	-0.6858	-0.6308	*****	*****	*****	-0.6308	*****
0.500	-0.8664	-1.0120	-0.9260	-0.8857	-0.7510	*****	*****	*****	-0.7510	*****
0.525	*****	-1.1995	-1.1276	-1.0042	-0.8195	*****	*****	*****	-0.8195	*****
0.550	-0.9331	-1.4283	-1.3568	-1.1219	-0.8659	*****	*****	*****	-0.8659	*****
0.575	*****	-1.6992	-1.6165	-1.2501	-0.9238	*****	*****	*****	-0.9238	*****
0.600	-1.3000	-2.0591	-1.9278	-1.3585	-0.9504	*****	*****	*****	-0.9504	*****
0.625	*****	*****	-2.1164	-1.4457	-0.9550	*****	*****	*****	-0.9550	*****
0.650	-2.3667	-2.9066	-2.2998	-1.4847	-0.9340	*****	*****	*****	-0.9340	*****
0.675	*****	-3.2977	-2.3390	-1.4952	-0.8688	*****	*****	*****	-0.8688	*****
0.700	-3.6545	-3.3790	-2.1839	-1.4581	-0.7915	*****	*****	*****	-0.7915	*****
0.725	*****	-3.1194	*****	-1.3690	-0.6816	*****	*****	*****	-0.6816	*****
0.750	-4.3019	-2.6215	*****	-1.2121	-0.5381	*****	*****	*****	-0.5381	*****
0.775	*****	-2.1896	-1.4122	-1.0366	-0.4273	*****	*****	*****	-0.4273	*****
0.800	-3.3108	-2.1049	-1.3013	-0.9061	*****	*****	*****	*****	*****	*****
0.825	*****	-2.0993	-1.2785	-0.8765	-0.4111	*****	*****	*****	-0.4111	*****
0.850	-3.0174	-2.1098	-1.2557	-0.8700	-0.4199	*****	*****	*****	-0.4199	*****
0.875	*****	-2.1177	-1.2499	-0.8646	-0.4038	*****	*****	*****	-0.4038	*****
0.900	-2.8686	-2.0712	-1.2454	-0.8668	-0.3793	*****	*****	*****	-0.3793	*****
0.925	*****	-1.9912	-1.2213	-0.8596	-0.4012	*****	*****	*****	-0.4012	*****
0.950	-2.6614	-1.9583	-1.1922	-0.8037	-0.3544	*****	*****	*****	-0.3544	*****
0.975	*****	-1.9401	-1.1804	-0.7538	-0.2928	*****	*****	*****	-0.2928	*****
1.000	-2.8337	-1.9929	-1.2286	-0.7708	-0.3277	*****	*****	*****	-0.3277	*****
-0.200	$C_{p,l}$	0.5905	0.5228	0.4595	*****	*****	*****	*****	-0.2859	*****
-0.400	$C_{p,l}$	0.5739	0.5245	0.4408	0.2403	-0.3787	*****	*****	-0.3787	*****
-0.600	$C_{p,l}$	0.5456	0.5121	0.4389	0.2647	-0.4691	*****	*****	-0.4691	*****
-0.700	$C_{p,l}$	0.4861	0.4881	0.4414	0.2790	-0.4632	*****	*****	-0.4632	*****
-0.800	$C_{p,l}$	0.3485	*****	0.4077	0.2950	-0.3839	*****	*****	-0.3839	*****
-0.850	$C_{p,l}$	*****	0.3404	0.3719	0.2908	-0.3468	*****	*****	-0.3468	*****
-0.900	$C_{p,l}$	*****	0.1668	0.2769	0.2682	-0.2706	*****	*****	-0.2706	*****
-0.950	$C_{p,l}$	-0.5576	-0.2410	0.0096	0.1312	-0.0233	*****	*****	-0.0233	*****
-0.975	$C_{p,l}$	*****	-0.7935	-0.3652	-0.0994	0.0098	*****	*****	0.0098	*****
-1.000	$C_{p,l}$	-3.0157	-2.0614	-1.2073	-0.8310	-0.3966	*****	*****	-0.3966	*****

Medium Radius L.E.
 Run No. = 29 , Point No. = 597
 $C_N = 1.211$, $C_m = -0.1495$
 $\alpha = 26.5^\circ$, $M_\infty = 0.400$
 $R_{mac} = 72.6 \times 10^6$



x/c_R	starb'd C_p	port C_p
0.10	-3.9544	*****
0.20	-2.8337	-3.0157
0.30	-2.3240	*****
0.40	-1.9929	-2.0614
0.50	-1.6216	*****
0.60	-1.2286	-1.2073
0.70	-0.9109	*****
0.80	-0.7708	-0.8310
0.90	*****	*****
0.95	-0.3277	-0.3966

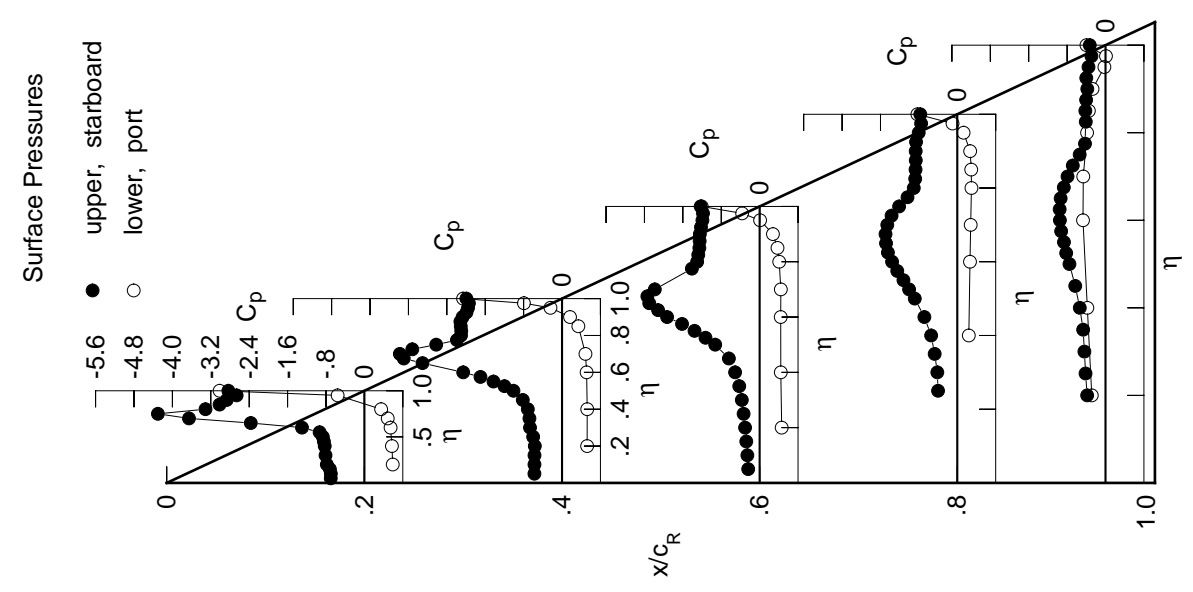

Appendix D

Experimental Surface Pressure Data for 65° Delta Wing, $M_\infty = 0.60$

The experimental surface pressure data for the 65° delta wing at constant $M_\infty = 0.60$ are summarized in tables D1–D3. Because of the extensive data contained in these tables, they have not been included in the printed copy of the paper but are available electronically from the Langley Technical Report Server (LTRS). Open the files with the following Uniform Resource Locator (URL):

<ftp://techreports.larc.nasa.gov/pub/techreports/larc/96/NASA-96-tm4645vol3appD.ps.Z>

Table D1. Tabulations and Plots of Surface Pressure Coefficients.

η	x/c_R .2	$C_{p,u}$	x/c_R .4	$C_{p,u}$	x/c_R .6	$C_{p,u}$	x/c_R .8	$C_{p,u}$	x/c_R .95
0.050		-0.0149	-0.0030	0.1048	0.1048	0.1048	0.1048	0.1048	0.1048
0.100		-0.0144	0.0024	0.0885	0.0885	0.0885	0.0885	0.0885	0.0885
0.150		-0.0196	-0.0012	0.0801	0.0801	0.0801	0.0801	0.0801	0.0801
0.200		-0.0175	0.0010	0.0645	0.0645	0.0645	0.0645	0.0645	0.0645
0.250		0.0000	-0.0032	0.0528	-0.1030	-0.2867	-0.2867	-0.2867	-0.2867
0.300		-0.0272	-0.0004	0.0428	-0.0917	-0.3120	-0.3120	-0.3120	-0.3120
0.350		0.0000	-0.0033	0.0316	-0.0804	-0.3185	-0.3185	-0.3185	-0.3185
0.400		-0.0370	-0.0013	0.0256	-0.0772	-0.3325	-0.3325	-0.3325	-0.3325
0.450		-0.0427	-0.0047	0.0237	-0.0785	-0.3356	-0.3356	-0.3356	-0.3356
0.500		-0.0519	-0.0050	0.0094	-0.0674	-0.3491	-0.3491	-0.3491	-0.3491
0.525		0.0000	-0.0050	0.0085	-0.0688	-0.3497	-0.3497	-0.3497	-0.3497
0.550		-0.0603	-0.0133	0.0062	-0.0681	-0.3506	-0.3506	-0.3506	-0.3506
0.575		0.0000	-0.0108	0.0100	-0.0703	-0.3586	-0.3586	-0.3586	-0.3586
0.600		-0.0609	-0.0164	0.0036	-0.0672	-0.3613	-0.3613	-0.3613	-0.3613
0.625		0.0000	0.0000	-0.0014	-0.0639	-0.3638	-0.3638	-0.3638	-0.3638
0.650		-0.0596	-0.0359	-0.0015	-0.0672	-0.3633	-0.3633	-0.3633	-0.3633
0.675		0.0000	-0.0409	-0.0078	-0.0698	-0.3573	-0.3573	-0.3573	-0.3573
0.700		-0.0573	-0.0469	-0.0068	-0.0652	-0.3606	-0.3606	-0.3606	-0.3606
0.725		0.0000	-0.0555	0.0000	-0.0691	-0.3526	-0.3526	-0.3526	-0.3526
0.750		-0.0473	-0.0572	0.0000	-0.0689	-0.3435	-0.3435	-0.3435	-0.3435
0.775		0.0000	-0.0638	-0.0418	-0.0692	-0.3294	-0.3294	-0.3294	-0.3294
0.800		-0.0331	-0.0669	-0.0509	-0.0785	0.0000	0.0000	0.0000	0.0000
0.825		0.0000	-0.0638	-0.0594	-0.0902	-0.3555	-0.3555	-0.3555	-0.3555
0.850		-0.0111	-0.0637	-0.0659	-0.1044	-0.3930	-0.3930	-0.3930	-0.3930
0.875		0.0000	-0.0532	-0.0699	-0.1134	-0.4635	-0.4635	-0.4635	-0.4635
0.900		0.0206	-0.0408	-0.0677	-0.1187	-0.5827	-0.5827	-0.5827	-0.5827
0.925		0.0000	-0.0213	-0.0515	-0.1169	-0.8918	-0.8918	-0.8918	-0.8918
0.950		0.0686	0.0140	-0.0260	-0.0874	-0.4618	-0.4618	-0.4618	-0.4618
0.975		0.0000	0.0654	0.0295	-0.0285	-0.2306	-0.2306	-0.2306	-0.2306
1.000		0.1902	0.1782	0.1318	0.1325	0.0811	0.0811	0.0811	0.0811

η	$C_{p,l}$	x/c_R .2	$C_{p,l}$	x/c_R .4	$C_{p,l}$	x/c_R .6	$C_{p,l}$	x/c_R .8	$C_{p,l}$	x/c_R .95
-0.200	-0.0399	-0.0200	0.0528	0.0528	0.0528	0.0528	0.0528	0.0528	0.0528	0.0528
-0.400	-0.0647	-0.0132	0.0072	-0.0849	-0.3259	-0.3259	-0.3259	-0.3259	-0.3259	-0.3259
-0.600	-0.0933	-0.0384	-0.0171	-0.0839	-0.3470	-0.3470	-0.3470	-0.3470	-0.3470	-0.3470
-0.700	-0.0940	-0.0790	-0.0317	-0.0853	-0.3944	-0.3944	-0.3944	-0.3944	-0.3944	-0.3944
-0.800	-0.0818	-0.1054	-0.0850	-0.0992	-0.4335	-0.4335	-0.4335	-0.4335	-0.4335	-0.4335
-0.850	-0.0621	-0.1080	-0.1105	-0.1387	-0.4917	-0.4917	-0.4917	-0.4917	-0.4917	-0.4917
-0.900	0.0000	-0.0981	-0.1209	-0.1715	-0.6763	-0.6763	-0.6763	-0.6763	-0.6763	-0.6763
-0.950	0.0125	-0.0512	-0.0958	-0.1600	-0.4737	-0.4737	-0.4737	-0.4737	-0.4737	-0.4737
-0.975	0.0000	-0.0020	-0.0469	-0.1116	-0.2819	-0.2819	-0.2819	-0.2819	-0.2819	-0.2819
-1.000	0.1786	0.1652	0.1372	0.1245	0.0811	0.0811	0.0811	0.0811	0.0811	0.0811

Medium Radius L.E.
 Run No. = 4, Point No. = 59
 $C_N = -0.029$, $C_m = 0.0070$
 $\alpha = -0.4^\circ$, $M_\infty = 0.599$
 $R_{mac} = 6.0 \times 10^6$

Leading Edge Pressures

- starboard
- port

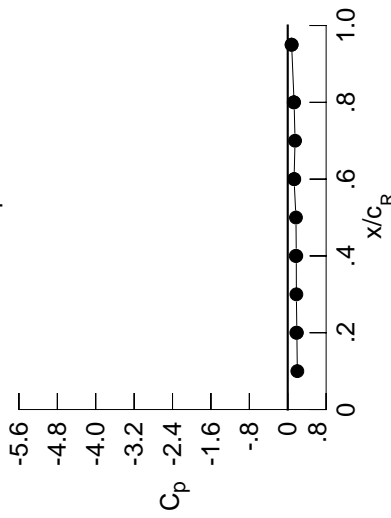

x/c_R	starb'd C_p	port C_p
0.10	0.1998	0.1998
0.20	0.1902	0.1786
0.30	0.1799	0.1786
0.40	0.1782	0.1652
0.50	0.1713	0.1652
0.60	0.1318	0.1372
0.70	0.1525	0.1525
0.80	0.1325	0.1245
0.90	0.0811	0.0811
0.95	0.0811	0.0811

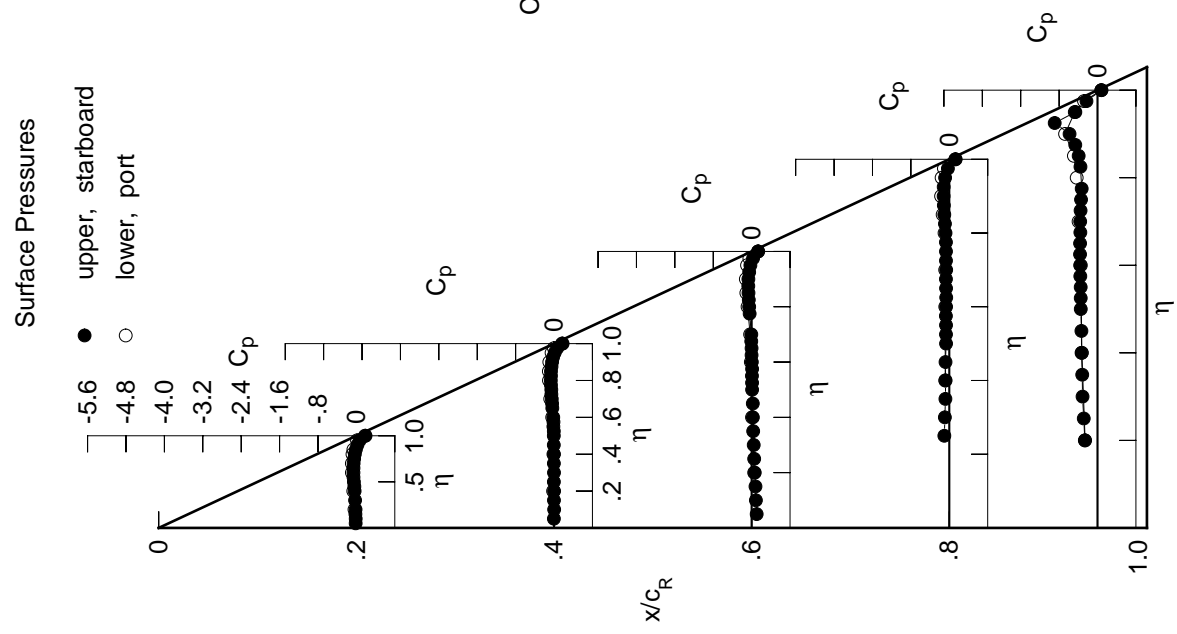
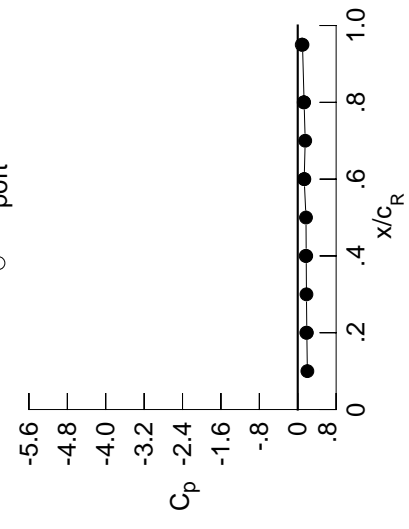

Table D1. Continued.

η	x/c_R .2	x/c_R .4	x/c_R .6	x/c_R .8	x/c_R .95
	$C_{p,u}$	$C_{p,u}$	$C_{p,u}$	$C_{p,u}$	$C_{p,u}$
0.050	-0.0151	0.0003	0.1041	*****	*****
0.100	-0.0143	0.0007	0.0882	*****	*****
0.150	-0.0180	0.0002	0.0776	*****	*****
0.200	-0.0213	0.0011	0.0640	*****	-0.2643
0.250	*****	-0.0019	0.0529	-0.1027	-0.2848
0.300	-0.0286	0.0010	0.0414	-0.0871	-0.3105
0.350	*****	-0.0038	0.0308	-0.0810	-0.3160
0.400	-0.0376	-0.0005	0.0288	-0.0773	-0.3326
0.450	-0.0436	-0.0083	0.0246	-0.0779	-0.3331
0.500	-0.0525	-0.0026	0.0090	-0.0668	-0.3455
0.525	*****	-0.0070	0.0111	-0.0690	-0.3482
0.550	-0.0580	-0.0100	0.0046	-0.0656	-0.3493
0.575	*****	-0.0107	0.0099	-0.0697	-0.3570
0.600	-0.0616	-0.0135	0.0031	-0.0679	-0.3595
0.625	*****	*****	-0.0006	-0.0635	-0.3630
0.650	-0.0608	-0.0366	-0.0013	-0.0684	-0.3602
0.675	*****	-0.0373	-0.0079	-0.0678	-0.3559
0.700	-0.0588	-0.0501	-0.0050	-0.0681	-0.3580
0.725	*****	-0.0518	*****	-0.0662	-0.3515
0.750	-0.0470	-0.0587	*****	-0.0684	-0.3406
0.775	*****	-0.0614	-0.0392	-0.0675	-0.3258
0.800	-0.0336	-0.0674	-0.0507	-0.0807	*****
0.825	*****	-0.0619	-0.0586	-0.0906	-0.3530
0.850	-0.0113	-0.0604	-0.0636	-0.1013	-0.3941
0.875	*****	-0.0506	-0.0724	-0.1137	-0.4636
0.900	0.0206	-0.0397	-0.0671	-0.1177	-0.5767
0.925	*****	-0.0208	-0.0502	-0.1157	-0.8984
0.950	0.0677	0.0128	-0.0245	-0.0877	-0.4605
0.975	*****	0.0651	0.0292	-0.0269	-0.2357
1.000	0.1895	0.1767	0.1348	0.1326	0.0994
	$C_{p,l}$	$C_{p,l}$	$C_{p,l}$	$C_{p,l}$	$C_{p,l}$
-0.200	-0.0414	-0.0195	0.0532	*****	-0.2574
-0.400	-0.0652	-0.0128	0.0100	-0.0854	-0.3230
-0.600	-0.0931	-0.0280	-0.0183	-0.0806	-0.3438
-0.700	-0.0939	-0.0793	-0.0278	-0.0862	-0.3923
-0.800	-0.0804	-0.1051	-0.0849	-0.0979	-0.4324
-0.850	-0.0623	-0.1096	-0.1096	-0.1394	-0.4897
-0.900	*****	-0.0987	-0.1235	-0.1716	-0.6752
-0.950	0.0128	-0.0534	-0.0947	-0.1606	-0.4715
-0.975	*****	-0.0025	-0.0458	-0.1118	-0.2822
-1.000	0.1780	0.1660	0.1365	0.1252	0.0834

Medium Radius L.E.
 Run No. = 4, Point No. = 60
 $C_N = -0.033$, $C_m = 0.0098$
 $\alpha = -0.4^\circ$, $M_\infty = 0.599$
 $R_{mac} = 6.0 \times 10^6$

Leading Edge Pressures
 ● starboard
 ○ port



x/c_R	starb'd C_p	port C_p
0.10	0.2005	*****
0.20	0.1895	0.1780
0.30	0.1816	*****
0.40	0.1767	0.1660
0.50	0.1720	*****
0.60	0.1348	0.1365
0.70	0.1557	*****
0.80	0.1326	0.1252
0.90	*****	*****
0.95	0.0994	0.0834

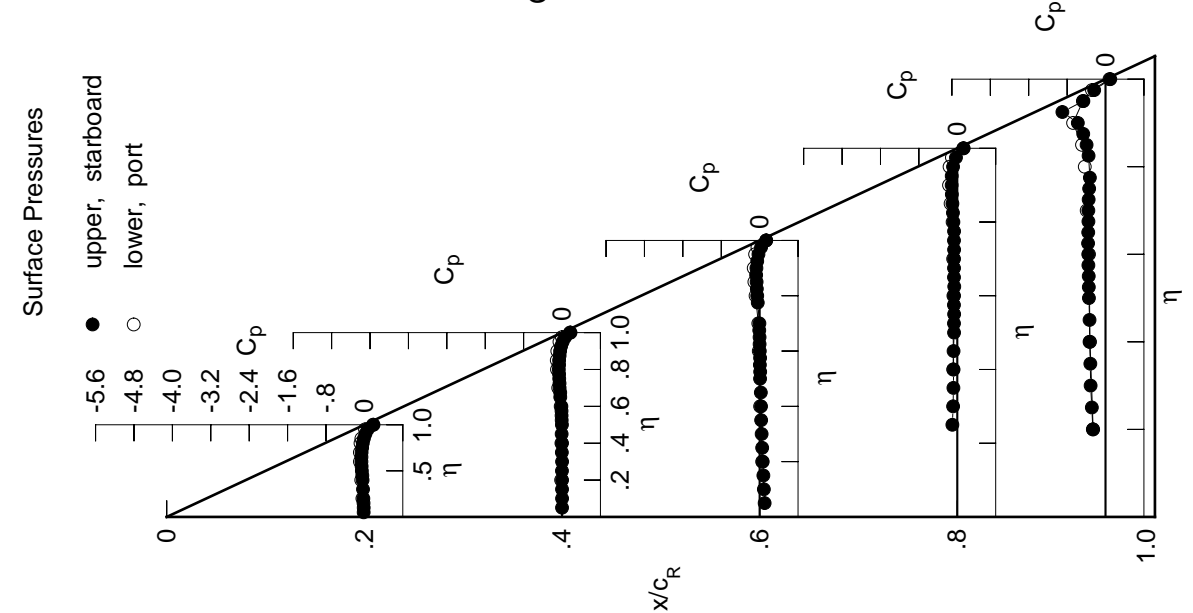
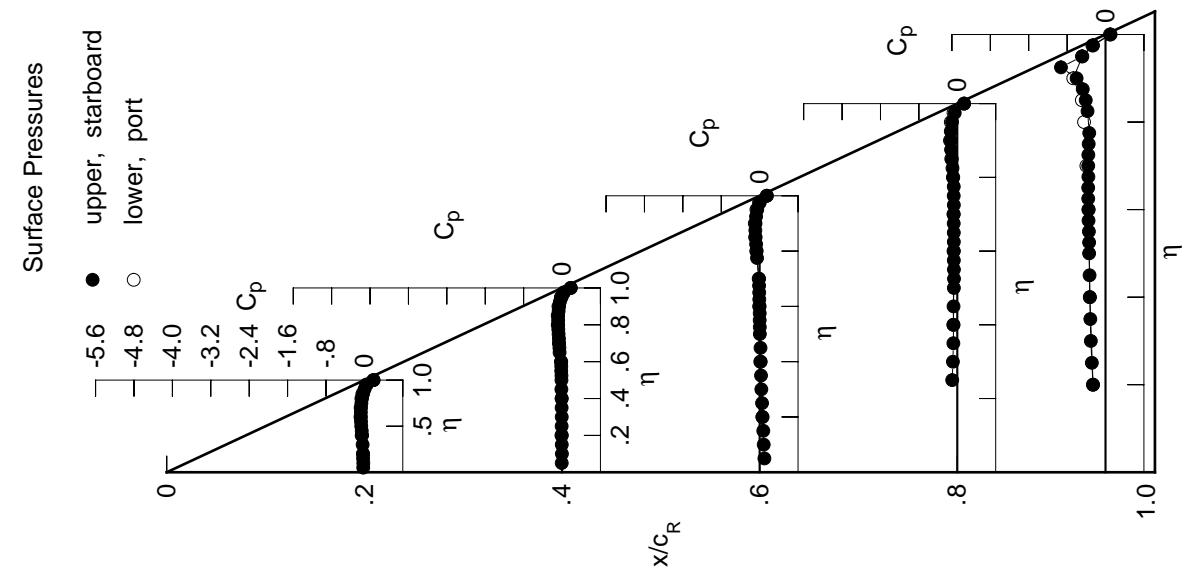
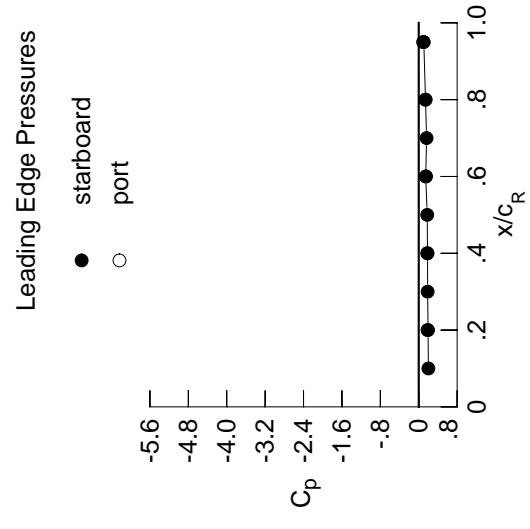

Table D1. Continued.

η	x/c_R .2	x/c_R .4	x/c_R .6	x/c_R .8	x/c_R .95
	$C_{p,u}$	$C_{p,u}$	$C_{p,u}$	$C_{p,u}$	$C_{p,u}$
0.050	-0.0242	-0.0061	0.0993	*****	*****
0.100	-0.0224	-0.0023	0.0851	*****	*****
0.150	-0.0272	-0.0053	0.0758	*****	*****
0.200	-0.0266	-0.0050	0.0594	*****	-0.2615
0.250	*****	-0.0084	0.0504	-0.1060	-0.2844
0.300	-0.0365	-0.0067	0.0356	-0.0911	-0.3059
0.350	*****	-0.0089	0.0287	-0.0812	-0.3162
0.400	-0.0476	-0.0077	0.0223	-0.0796	-0.3259
0.450	-0.0550	-0.0134	0.0186	-0.0787	-0.3321
0.500	-0.0659	-0.0118	0.0043	-0.0712	-0.3419
0.525	*****	-0.0121	0.0028	-0.0692	-0.3419
0.550	-0.0701	-0.0167	0.0005	-0.0703	-0.3465
0.575	*****	-0.0161	0.0015	-0.0722	-0.3532
0.600	-0.0733	-0.0169	-0.0003	-0.0727	-0.3564
0.625	*****	*****	-0.0068	-0.0720	-0.3600
0.650	-0.0739	-0.0511	-0.0086	-0.0731	-0.3605
0.675	*****	-0.0548	-0.0117	-0.0743	-0.3567
0.700	-0.0723	-0.0633	-0.0108	-0.0735	-0.3598
0.725	*****	-0.0651	*****	-0.0720	-0.3576
0.750	-0.0626	-0.0723	*****	-0.0747	-0.3503
0.775	*****	-0.0779	-0.0540	-0.0740	-0.3393
0.800	-0.0502	-0.0799	-0.0628	-0.0839	*****
0.825	*****	-0.0807	-0.0736	-0.1003	-0.3740
0.850	-0.0289	-0.0810	-0.0832	-0.1145	-0.4120
0.875	*****	-0.0716	-0.0894	-0.1294	-0.4737
0.900	0.0023	-0.0608	-0.0854	-0.1386	-0.6021
0.925	*****	-0.0445	-0.0746	-0.1348	-0.9280
0.950	0.0476	-0.0076	-0.0497	-0.1105	-0.4886
0.975	*****	0.0400	0.0015	-0.0540	-0.2601
1.000	0.1940	0.1831	0.1455	0.1416	0.1054
	$C_{p,l}$	$C_{p,l}$	$C_{p,l}$	$C_{p,l}$	$C_{p,l}$
-0.200	-0.0312	-0.0118	0.0573	*****	-0.2590
-0.400	-0.0572	-0.0080	0.0136	-0.0817	-0.3269
-0.600	-0.0805	-0.0231	-0.0106	-0.0776	-0.3503
-0.700	-0.0783	-0.0622	-0.0196	-0.0797	-0.3986
-0.800	-0.0624	-0.0893	-0.0699	-0.0911	-0.4469
-0.850	-0.0427	-0.0897	-0.0934	-0.1254	-0.4940
-0.900	*****	-0.0745	-0.1010	-0.1525	-0.6722
-0.950	0.0358	-0.0251	-0.0673	-0.1350	-0.4821
-0.975	*****	0.0286	-0.0132	-0.0780	-0.2740
-1.000	0.1834	0.1773	0.1523	0.1416	0.0913

Medium Radius L.E.
 Run No. = 4, Point No. = 61
 $C_N = -0.017$, $C_m = 0.0076$
 $\alpha = 0.0^\circ$, $M_\infty = 0.599$
 $R_{mac} = 6.0 \times 10^6$



x/c_R	starbd C_p	port C_p
0.10	0.2018	*****
0.20	0.1940	0.1834
0.30	0.1857	*****
0.40	0.1831	0.1773
0.50	0.1768	*****
0.60	0.1455	0.1523
0.70	0.1631	*****
0.80	0.1416	0.1416
0.90	*****	*****
0.95	0.1054	0.0913

Table D1. Continued.

η	$x/c_R = .2$		$x/c_R = .4$		$x/c_R = .6$		$x/c_R = .8$		$x/c_R = .95$	
	$C_{p,u}$	$C_{p,u}$	$C_{p,u}$	$C_{p,u}$	$C_{p,u}$	$C_{p,u}$	$C_{p,u}$	$C_{p,u}$	$C_{p,u}$	$C_{p,u}$
0.050	-0.0436	-0.0231	0.0873	0.0873	0.0873	0.0873	0.0873	0.0873	0.0873	0.0873
0.100	-0.0420	-0.0173	0.0755	0.0755	0.0755	0.0755	0.0755	0.0755	0.0755	0.0755
0.150	-0.0443	-0.0221	0.0654	0.0654	0.0654	0.0654	0.0654	0.0654	0.0654	0.0654
0.200	-0.0454	-0.0199	0.0462	0.0462	0.0462	0.0462	0.0462	0.0462	0.0462	0.0462
0.250	*****	-0.0228	0.0410	-0.1123	0.0410	-0.1123	0.0410	-0.1123	0.0410	-0.2561
0.300	-0.0517	-0.0231	0.0212	-0.0984	0.0212	-0.0984	0.0212	-0.0984	0.0212	-0.2974
0.350	*****	-0.0226	0.0178	-0.0910	0.0178	-0.0910	0.0178	-0.0910	0.0178	-0.3045
0.400	-0.0714	-0.0282	0.0090	-0.0883	0.0090	-0.0883	0.0090	-0.0883	0.0090	-0.3171
0.450	-0.0838	-0.0295	0.0049	-0.0877	0.0049	-0.0877	0.0049	-0.0877	0.0049	-0.3197
0.500	-0.0910	-0.0318	-0.0096	-0.0825	-0.0096	-0.0825	-0.0096	-0.0825	-0.0096	-0.3334
0.525	*****	-0.0321	-0.0124	-0.0813	-0.0124	-0.0813	-0.0124	-0.0813	-0.0124	-0.3310
0.550	-0.0976	-0.0366	-0.0144	-0.0825	-0.0144	-0.0825	-0.0144	-0.0825	-0.0144	-0.3391
0.575	*****	-0.0379	-0.0160	-0.0868	-0.0160	-0.0868	-0.0160	-0.0868	-0.0160	-0.3389
0.600	-0.1030	-0.0309	-0.0184	-0.0838	-0.0184	-0.0838	-0.0184	-0.0838	-0.0184	-0.3474
0.625	*****	*****	-0.0218	-0.0833	-0.0218	-0.0833	-0.0218	-0.0833	-0.0218	-0.3514
0.650	-0.1065	-0.0865	-0.0276	-0.0876	-0.0276	-0.0876	-0.0276	-0.0876	-0.0276	-0.3523
0.675	*****	-0.0868	-0.0321	-0.0895	-0.0321	-0.0895	-0.0321	-0.0895	-0.0321	-0.3543
0.700	-0.1128	-0.0918	-0.0333	-0.0875	-0.0333	-0.0875	-0.0333	-0.0875	-0.0333	-0.3599
0.725	*****	-0.0975	*****	-0.0892	-0.0892	-0.0892	-0.0892	-0.0892	-0.0892	-0.3660
0.750	-0.0994	-0.1047	*****	-0.0899	-0.0899	-0.0899	-0.0899	-0.0899	-0.0899	-0.3627
0.775	*****	-0.1132	-0.0798	-0.0962	-0.0962	-0.0962	-0.0962	-0.0962	-0.0962	-0.3613
0.800	-0.0916	-0.1159	-0.1016	-0.0999	-0.1016	-0.0999	-0.1016	-0.0999	-0.1016	-0.3660
0.825	*****	-0.1226	-0.1096	-0.1355	-0.1096	-0.1355	-0.1096	-0.1355	-0.1096	-0.3961
0.850	-0.0727	-0.1278	-0.1199	-0.1500	-0.1199	-0.1500	-0.1199	-0.1500	-0.1199	-0.4394
0.875	*****	-0.1191	-0.1360	-0.1623	-0.1360	-0.1623	-0.1360	-0.1623	-0.1360	-0.4928
0.900	-0.0472	-0.1181	-0.1350	-0.1808	-0.1350	-0.1808	-0.1350	-0.1808	-0.1350	-0.6330
0.925	*****	-0.1025	-0.1325	-0.1879	-0.1325	-0.1879	-0.1325	-0.1879	-0.1325	-0.8815
0.950	-0.0043	-0.0710	-0.1177	-0.1738	-0.1177	-0.1738	-0.1177	-0.1738	-0.1177	-0.5097
0.975	*****	-0.0321	-0.0697	-0.1289	-0.0697	-0.1289	-0.0697	-0.1289	-0.0697	-0.3027
1.000	0.1773	0.1580	0.1213	0.1153	0.1213	0.1153	0.1213	0.1153	0.1213	0.0931
-0.200	$C_{p,l}$	0.0126	0.0088	0.0704	0.0088	0.0704	0.0088	0.0704	0.0088	-0.2695
-0.400	$C_{p,l}$	-0.0306	0.0136	0.0258	-0.0737	0.0258	-0.0737	0.0258	-0.0737	-0.3341
-0.600	$C_{p,l}$	-0.0516	-0.0056	0.0105	-0.0658	0.0105	-0.0658	0.0105	-0.0658	-0.3560
-0.700	$C_{p,l}$	-0.0433	-0.0341	-0.0010	-0.0645	-0.0341	-0.0645	-0.0341	-0.0645	-0.3885
-0.800	$C_{p,l}$	-0.0218	-0.0517	-0.0382	-0.0657	-0.0382	-0.0657	-0.0382	-0.0657	-0.4234
-0.850	$C_{p,l}$	0.0000	-0.0459	-0.0553	-0.0959	-0.0459	-0.0959	-0.0459	-0.0959	-0.4897
-0.900	$C_{p,l}$	*****	-0.0247	-0.0522	-0.1119	-0.0522	-0.1119	-0.0522	-0.1119	-0.6365
-0.950	$C_{p,l}$	-0.0829	0.0325	-0.0072	-0.0777	-0.0072	-0.0777	-0.0072	-0.0777	-0.4482
-0.975	$C_{p,l}$	*****	0.0883	0.0516	-0.0127	-0.0127	-0.0127	-0.0127	-0.0127	-0.2266
-1.000	$C_{p,l}$	0.1784	0.1657	0.1361	0.1319	0.1361	0.1319	0.1361	0.1319	0.0877

Medium Radius L.E.
 Run No. = 4, Point No. = 62
 $C_N = 0.029$, $C_m = -0.0043$
 $\alpha = 1.1^\circ$, $M_\infty = 0.599$
 $R_{mac} = 6.0 \times 10^6$

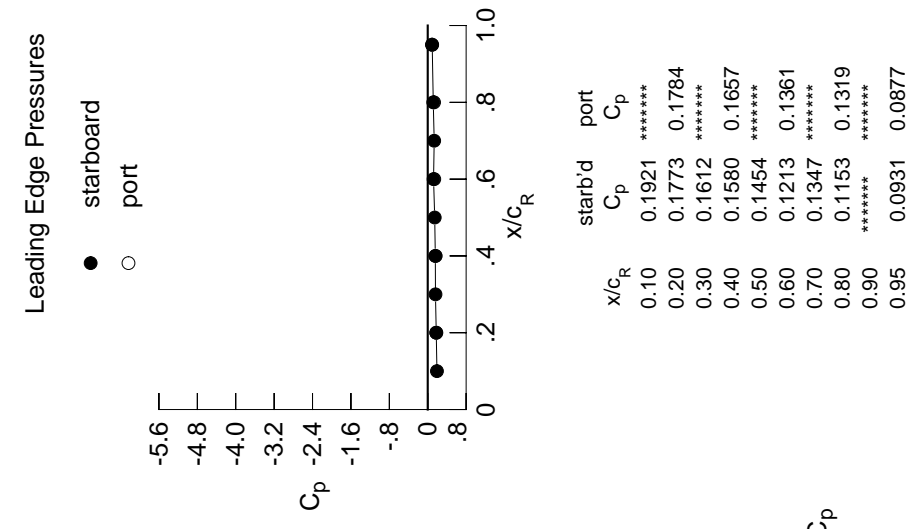
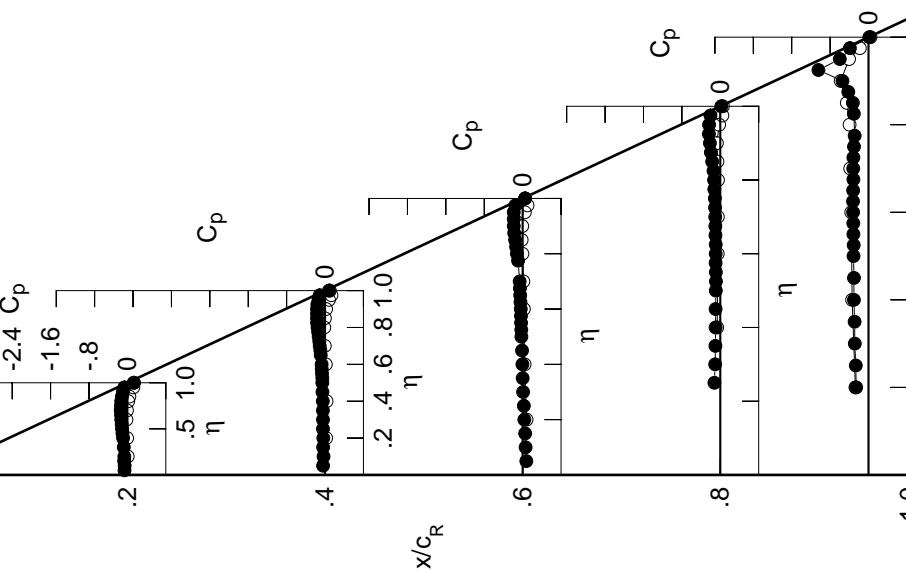
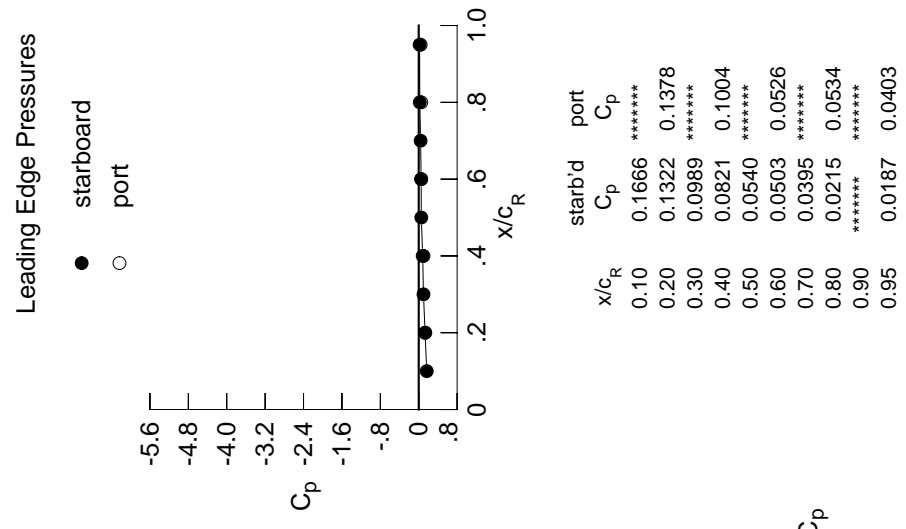

Table D1. Continued.

η	x/c_R	$C_{p,u}$	x/c_R	$C_{p,u}$	x/c_R	$C_{p,u}$	x/c_R	$C_{p,u}$
0.050	0.2	-0.0603	0.4	-0.0406	0.6	0.0765	0.8	0.0765
0.100		-0.0569		-0.0316		0.0614		0.0614
0.150		-0.0669		-0.0399		0.0529		0.0529
0.200		-0.0639		-0.0363		0.0352		0.0352
0.250		*****		-0.0431		0.0252		-0.1227
0.300		-0.0749		-0.0427		0.0096		-0.1065
0.350		*****		-0.0446		0.0003		-0.1014
0.400		-0.0898		-0.0467		-0.0050		-0.3040
0.450		-0.1025		-0.0536		-0.0129		-0.0977
0.500		-0.1113		-0.0568		-0.0267		-0.0928
0.525		*****		-0.0563		-0.0280		-0.0907
0.550		-0.1181		-0.0634		-0.0331		-0.0925
0.575		*****		-0.0689		-0.0349		-0.0972
0.600		-0.1283		-0.0709		-0.0391		-0.0955
0.625		*****		*****		-0.0444		-0.0950
0.650		-0.1320		-0.0897		-0.0514		-0.1007
0.675		*****		-0.0967		-0.0568		-0.1034
0.700		-0.1402		-0.1113		-0.0626		-0.1055
0.725		*****		-0.1200		*****		-0.1088
0.750		-0.1343		-0.1324		*****		-0.1126
0.775		*****		-0.1432		-0.0950		-0.1246
0.800		-0.1287		-0.1557		-0.1191		-0.1292
0.825		*****		-0.1648		-0.1362		-0.1419
0.850		-0.1150		-0.1667		-0.1570		-0.1691
0.875		*****		-0.1672		-0.1761		-0.1964
0.900		-0.0939		-0.1665		-0.1852		-0.2161
0.925		*****		-0.1610		-0.1852		-0.2373
0.950		-0.0621		-0.1354		-0.1855		-0.2339
0.975		*****		-0.1108		-0.1513		-0.2045
1.000		0.1322		0.0821		0.0503		0.0215
-0.200		$C_{p,l}$		$C_{p,l}$		$C_{p,l}$		$C_{p,l}$
-0.400		0.0065		0.0228		0.0819		0.0819
-0.600		-0.0054		0.0313		0.0405		-0.0647
-0.700		-0.0085		0.0159		0.0245		-0.0526
-0.800		0.0176		-0.0157		-0.0046		-0.0478
-0.850		0.0406		-0.0035		-0.0208		-0.0593
-0.900		*****		0.0217		-0.0084		-0.0707
-0.950		0.1243		0.0820		0.0453		-0.0241
-0.975		*****		0.1336		0.1027		0.0429
-1.000		0.1378		0.1004		0.0526		0.0534

Medium Radius L.E.
 Run No. = 4, Point No. = 63
 $C_N = 0.061$, $C_m = -0.0057$
 $\alpha = 2.1^\circ$, $M_\infty = 0.599$
 $R_{mac} = 6.0 \times 10^6$



x/c_R	starb'd C_p	port C_p
0.10	0.1666	*****
0.20	0.1322	0.1378
0.30	0.0989	*****
0.40	0.0821	0.1004
0.50	0.0540	*****
0.60	0.0503	0.0526
0.70	0.0395	*****
0.80	0.0215	0.0534
0.90	*****	*****
0.95	0.0187	0.0403

Table D1. Continued.

η	x/c_R	x/c_R	x/c_R	x/c_R	x/c_R	x/c_R	x/c_R
	$C_{p,u}$	$C_{p,u}$	$C_{p,u}$	$C_{p,u}$	$C_{p,u}$	$C_{p,i}$	$C_{p,i}$
0.050	-0.0788	-0.0496	0.0689	0.0689	0.0689	0.0950	0.0950
0.100	-0.0760	-0.0480	0.0544	0.0544	0.0544	0.0554	0.0554
0.150	-0.0798	-0.0554	0.0443	0.0443	0.0443	0.0405	0.0405
0.200	-0.0832	-0.0518	0.0254	0.0254	0.0254	0.0208	0.0208
0.250	*****	-0.0543	0.0164	0.0164	0.0164	0.0172	0.0172
0.300	-0.0965	-0.0567	-0.0004	-0.1110	-0.2761	0.0128	0.0128
0.350	*****	-0.0598	-0.0097	-0.1056	-0.2800	0.0279	0.0279
0.400	-0.1135	-0.0632	-0.0158	-0.1039	-0.2949	0.0570	0.0570
0.450	-0.1229	-0.0697	-0.0227	-0.1055	-0.2892	0.0816	0.0816
0.500	-0.1354	-0.0726	-0.0378	-0.0988	-0.3022	*****	0.0672
0.525	*****	-0.0783	-0.0438	-0.0995	-0.2983	0.1610	0.1610
0.550	-0.1443	-0.0837	-0.0457	-0.1019	-0.3027	*****	0.1251
0.575	*****	-0.0885	-0.0487	-0.1046	-0.3031	0.1702	0.1702
0.600	-0.1566	-0.0924	-0.0540	-0.1061	-0.3066	0.0679	0.0679
0.625	*****	*****	-0.0623	-0.1050	-0.3083	-0.0123	-0.0123
0.650	-0.1654	-0.1140	-0.0669	-0.1109	-0.3064	-0.0939	-0.0939
0.675	*****	-0.1224	-0.0773	-0.1146	-0.3005	0.0859	0.0859
0.700	-0.1737	-0.1379	-0.0799	-0.1193	-0.3045	0.1432	0.1432
0.725	*****	-0.1507	*****	-0.1218	-0.2988	0.0859	0.0859
0.750	-0.1732	-0.1673	*****	-0.1295	-0.2837	0.0909	0.0909
0.775	*****	-0.1784	-0.1237	-0.1375	-0.2609	0.1432	0.1432
0.800	-0.1705	-0.1947	-0.1479	-0.1528	*****	0.0859	0.0859
0.825	*****	-0.2085	-0.1717	-0.1646	-0.2738	0.0859	0.0859
0.850	-0.1609	-0.2176	-0.1964	-0.1995	-0.3033	0.0859	0.0859
0.875	*****	-0.2198	-0.2221	-0.2304	-0.4008	0.0859	0.0859
0.900	-0.1465	-0.2277	-0.2399	-0.2643	-0.5339	0.0859	0.0859
0.925	*****	-0.2265	-0.2512	-0.2934	-1.0642	0.0859	0.0859
0.950	-0.1264	-0.2125	-0.2577	-0.3030	-0.6376	0.0859	0.0859
0.975	*****	-0.2048	-0.2496	-0.2984	-0.4523	0.0859	0.0859
1.000	0.0585	-0.0428	-0.0609	-0.1349	-0.0793	0.0859	0.0859

Medium Radius L.E.
 Run No. = 4, Point No. = 64
 $C_N = 0.100$, $C_m = -0.0125$
 $\alpha = 3.2^\circ$, $M_\infty = 0.599$
 $R_{mac} = 6.0 \times 10^6$

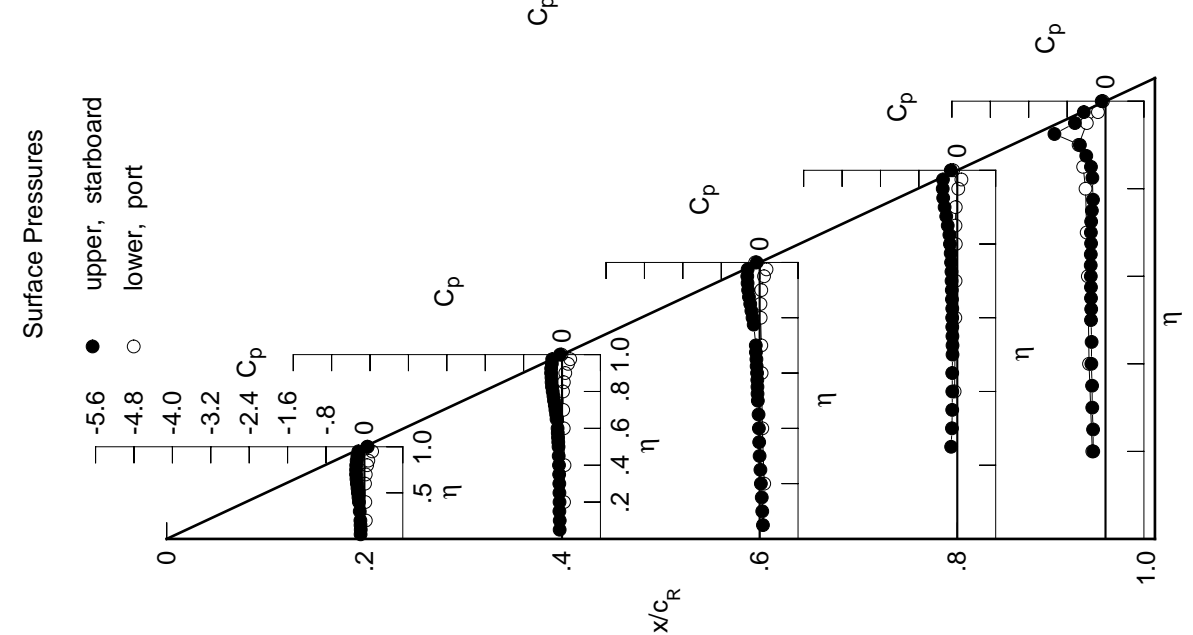

Leading Edge Pressures
 ● starboard
 ○ port

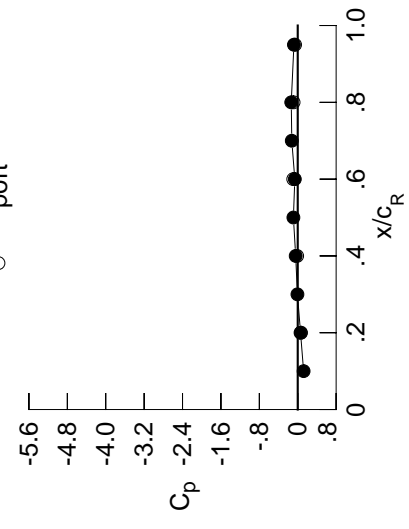

x/c_R	starb'd C_p	port C_p
0.10	0.1225	*****
0.20	0.0585	0.0679
0.30	-0.0062	*****
0.40	-0.0428	-0.0123
0.50	-0.0901	*****
0.60	-0.0609	-0.0939
0.70	-0.1238	*****
0.80	-0.1349	-0.0865
0.90	*****	*****
0.95	-0.0793	-0.0548

Table D1. Continued.

η	x/c_R	$C_{p,u}$	x/c_R	$C_{p,u}$	x/c_R	$C_{p,u}$	x/c_R	$C_{p,u}$	x/c_R	$C_{p,u}$
0.050	0.0965	-0.0658	0.0568	0.0568	0.0568	0.0568	0.0568	0.0568	0.0568	0.0568
0.100	-0.0936	-0.0649	0.0419	0.0419	0.0419	0.0419	0.0419	0.0419	0.0419	0.0419
0.150	-0.1018	-0.0707	0.0281	0.0281	0.0281	0.0281	0.0281	0.0281	0.0281	0.0281
0.200	-0.1048	-0.0690	0.0148	0.0148	0.0148	0.0148	0.0148	0.0148	0.0148	0.0148
0.250	0.0000	-0.0733	0.0057	-0.1341	-0.1341	-0.1341	-0.1341	-0.1341	-0.1341	-0.1341
0.300	-0.1155	-0.0747	-0.0125	-0.1209	-0.1209	-0.1209	-0.1209	-0.1209	-0.1209	-0.1209
0.350	0.0000	-0.0778	-0.0241	-0.1117	-0.1117	-0.1117	-0.1117	-0.1117	-0.1117	-0.1117
0.400	-0.1358	-0.0811	-0.0300	-0.1103	-0.1103	-0.1103	-0.1103	-0.1103	-0.1103	-0.1103
0.450	-0.1514	-0.0886	-0.0367	-0.1095	-0.1095	-0.1095	-0.1095	-0.1095	-0.1095	-0.1095
0.500	-0.1626	-0.0951	-0.0560	-0.1107	-0.1107	-0.1107	-0.1107	-0.1107	-0.1107	-0.1107
0.525	0.0000	-0.0972	-0.0578	-0.1089	-0.1089	-0.1089	-0.1089	-0.1089	-0.1089	-0.1089
0.550	-0.1739	-0.1056	-0.0639	-0.1128	-0.1128	-0.1128	-0.1128	-0.1128	-0.1128	-0.1128
0.575	0.0000	-0.1095	-0.0684	-0.1172	-0.1172	-0.1172	-0.1172	-0.1172	-0.1172	-0.1172
0.600	-0.1885	-0.1169	-0.0726	-0.1172	-0.1172	-0.1172	-0.1172	-0.1172	-0.1172	-0.1172
0.625	0.0000	0.0000	-0.0801	-0.1177	-0.1177	-0.1177	-0.1177	-0.1177	-0.1177	-0.1177
0.650	-0.1994	-0.1375	-0.0895	-0.1237	-0.1237	-0.1237	-0.1237	-0.1237	-0.1237	-0.1237
0.675	0.0000	-0.1520	-0.0980	-0.1325	-0.1325	-0.1325	-0.1325	-0.1325	-0.1325	-0.1325
0.700	-0.2120	-0.1685	-0.1056	-0.1333	-0.1333	-0.1333	-0.1333	-0.1333	-0.1333	-0.1333
0.725	0.0000	-0.1823	0.0000	-0.1413	-0.1413	-0.1413	-0.1413	-0.1413	-0.1413	-0.1413
0.750	-0.2157	-0.2020	0.0000	-0.1484	-0.1484	-0.1484	-0.1484	-0.1484	-0.1484	-0.1484
0.775	0.0000	-0.2177	-0.1538	-0.1612	-0.1612	-0.1612	-0.1612	-0.1612	-0.1612	-0.1612
0.800	-0.2194	-0.2380	-0.1814	-0.1769	-0.1769	-0.1769	-0.1769	-0.1769	-0.1769	-0.1769
0.825	0.0000	-0.2578	-0.2099	-0.1931	-0.1931	-0.1931	-0.1931	-0.1931	-0.1931	-0.1931
0.850	-0.2156	-0.2668	-0.2402	-0.2264	-0.2264	-0.2264	-0.2264	-0.2264	-0.2264	-0.2264
0.875	0.0000	-0.2819	-0.2753	-0.2704	-0.2704	-0.2704	-0.2704	-0.2704	-0.2704	-0.2704
0.900	-0.2082	-0.2921	-0.3040	-0.3104	-0.3104	-0.3104	-0.3104	-0.3104	-0.3104	-0.3104
0.925	0.0000	-0.3058	-0.3256	-0.3539	-0.3539	-0.3539	-0.3539	-0.3539	-0.3539	-0.3539
0.950	-0.2022	-0.2960	-0.3490	-0.3801	-0.3801	-0.3801	-0.3801	-0.3801	-0.3801	-0.3801
0.975	0.0000	-0.3207	-0.3598	-0.4019	-0.4019	-0.4019	-0.4019	-0.4019	-0.4019	-0.4019
1.000	-0.0543	-0.2186	-0.2405	-0.3646	-0.3646	-0.3646	-0.3646	-0.3646	-0.3646	-0.3646
	$C_{p,l}$	$C_{p,l}$	$C_{p,l}$	$C_{p,l}$	$C_{p,l}$	$C_{p,l}$	$C_{p,l}$	$C_{p,l}$	$C_{p,l}$	$C_{p,l}$
-0.200	0.0474	0.0576	0.1071	0.0000	0.0000	0.0000	0.0000	0.0000	0.0000	0.0000
-0.400	0.0401	0.0619	0.0696	-0.0455	-0.0455	-0.0455	-0.0455	-0.0455	-0.0455	-0.0455
-0.600	0.0398	0.0574	0.0540	-0.0322	-0.0322	-0.0322	-0.0322	-0.0322	-0.0322	-0.0322
-0.700	0.0559	0.0483	0.0542	-0.0241	-0.0241	-0.0241	-0.0241	-0.0241	-0.0241	-0.0241
-0.800	0.0869	0.0509	0.0455	-0.0129	-0.0129	-0.0129	-0.0129	-0.0129	-0.0129	-0.0129
-0.850	0.1103	0.0685	0.0473	-0.0135	-0.0135	-0.0135	-0.0135	-0.0135	-0.0135	-0.0135
-0.900	0.0000	0.1006	0.0679	-0.0014	-0.0014	-0.0014	-0.0014	-0.0014	-0.0014	-0.0014
-0.950	0.1823	0.1535	0.1240	0.0564	0.0564	0.0564	0.0564	0.0564	0.0564	0.0564
-0.975	0.0000	0.1867	0.1669	0.1160	0.1160	0.1160	0.1160	0.1160	0.1160	0.1160
-1.000	-0.0422	-0.1851	-0.3186	-0.3056	-0.3056	-0.3056	-0.3056	-0.3056	-0.3056	-0.3056

Medium Radius L.E.
 Run No. = 4, Point No. = 65
 $C_N = 0.138$, $C_m = -0.0194$
 $\alpha = 4.2^\circ$, $M_\infty = 0.599$
 $R_{mac} = 6.0 \times 10^6$

Leading Edge Pressures

- starboard
- port

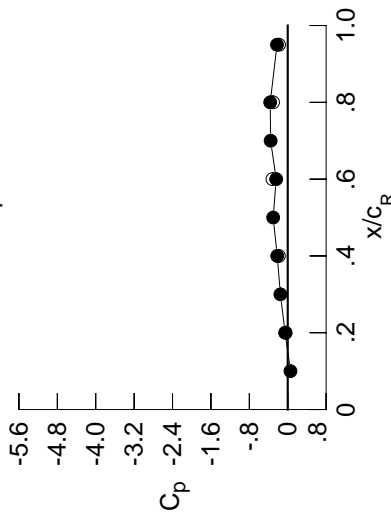

x/c_R	starb'd C_p	port C_p
0.10	0.0571	0.0571
0.20	-0.0543	-0.0422
0.30	-0.1527	0.0000
0.40	-0.2186	-0.1851
0.50	-0.3030	0.0000
0.60	-0.2405	-0.3186
0.70	-0.3562	0.0000
0.80	-0.3646	-0.3056
0.90	0.0000	0.0000
0.95	-0.2234	-0.1810

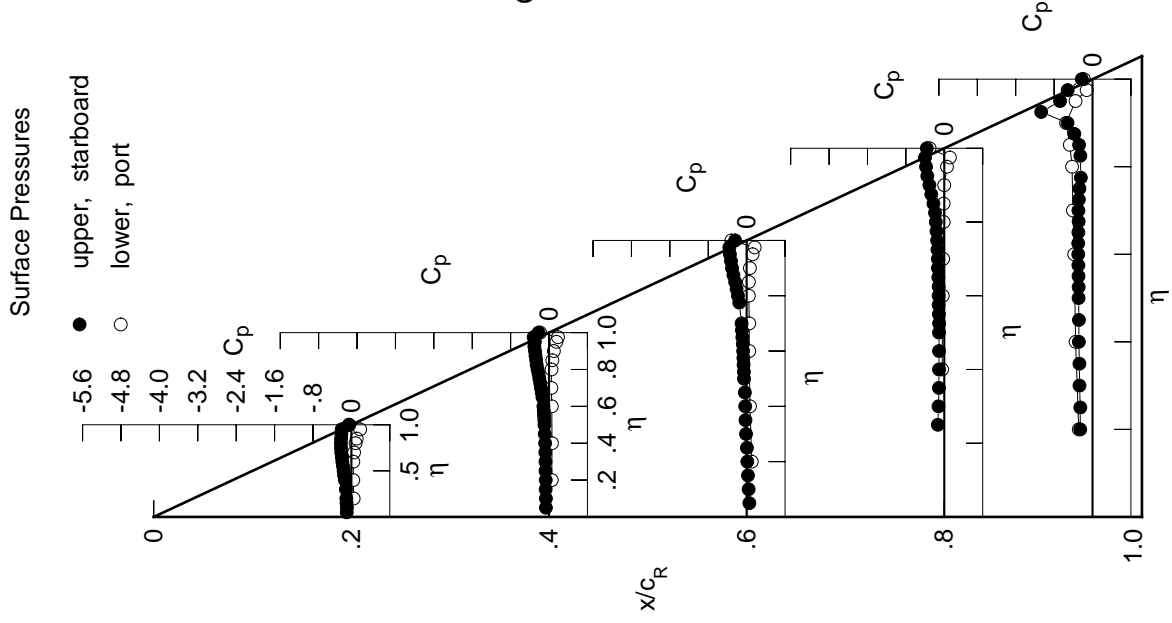

Table D1. Continued.

η	x/c_R	x/c_R	x/c_R	x/c_R	x/c_R	x/c_R	x/c_R
	$C_{p,u}$	$C_{p,u}$	$C_{p,u}$	$C_{p,u}$	$C_{p,u}$	$C_{p,i}$	$C_{p,i}$
0.050	-0.1189	-0.0804	0.0489	*****	*****	0.0669	0.0727
0.100	-0.1121	-0.0787	0.0324	*****	*****	0.0609	0.0863
0.150	-0.1182	-0.0821	0.0222	*****	*****	0.0666	0.0772
0.200	-0.1236	-0.0831	0.0035	*****	-0.2547	0.0844	0.0704
0.250	*****	-0.0841	-0.0055	-0.1389	-0.2516	0.1167	0.0796
0.300	-0.1358	-0.0887	-0.0249	-0.1256	-0.2643	0.1405	0.1010
0.350	*****	-0.0937	-0.0354	-0.1172	-0.2650	*****	0.1321
0.400	-0.1577	-0.0979	-0.0423	-0.1164	-0.2778	0.1948	0.1775
0.450	-0.1729	-0.1080	-0.0492	-0.1215	-0.2781	0.1948	0.1789
0.500	-0.1852	-0.1153	-0.0679	-0.1141	-0.2826	0.1948	0.1789
0.525	*****	-0.1182	-0.0718	-0.1165	-0.2859	0.1948	0.1789
0.550	-0.1990	-0.1271	-0.0799	-0.1201	-0.2808	0.1948	0.1789
0.575	*****	-0.1299	-0.0813	-0.1254	-0.2877	0.1948	0.1789
0.600	-0.2178	-0.1385	-0.0920	-0.1279	-0.2847	0.1948	0.1789
0.625	*****	*****	-0.0974	-0.1299	-0.2880	0.1948	0.1789
0.650	-0.2320	-0.1642	-0.1058	-0.1376	-0.2835	0.1948	0.1789
0.675	*****	-0.1762	-0.1176	-0.1415	-0.2737	0.1948	0.1789
0.700	-0.2492	-0.1964	-0.1262	-0.1513	-0.2753	0.1948	0.1789
0.725	*****	-0.2125	*****	-0.1528	-0.2677	0.1948	0.1789
0.750	-0.2581	-0.2372	*****	-0.1648	-0.2557	0.1948	0.1789
0.775	*****	-0.2518	-0.1807	-0.1799	-0.2234	0.1948	0.1789
0.800	-0.2653	-0.2823	-0.2128	-0.2032	*****	0.1948	0.1789
0.825	*****	-0.2996	-0.2424	-0.2183	-0.2192	0.1948	0.1789
0.850	-0.2685	-0.3214	-0.2820	-0.2571	-0.2497	0.1948	0.1789
0.875	*****	-0.3395	-0.3221	-0.3069	-0.3426	0.1948	0.1789
0.900	-0.2694	-0.3591	-0.3606	-0.3580	-0.4820	0.1948	0.1789
0.925	*****	-0.3782	-0.3964	-0.4145	-1.0407	0.1948	0.1789
0.950	-0.2808	-0.3871	-0.4374	-0.4574	-0.6950	0.1948	0.1789
0.975	*****	-0.4385	-0.4763	-0.5049	-0.5658	0.1948	0.1789
1.000	-0.1831	-0.4367	-0.4634	-0.6412	-0.3858	0.1948	0.1789
-0.200	$C_{p,i}$	$C_{p,i}$	$C_{p,i}$	$C_{p,i}$	$C_{p,i}$	$C_{p,i}$	$C_{p,i}$
-0.400	0.0669	0.0727	0.1161	*****	-0.2911	0.0669	0.0727
-0.600	0.0609	0.0863	0.0846	-0.0379	-0.3606	0.0609	0.0863
-0.700	0.0666	0.0772	0.0740	-0.0191	-0.3904	0.0666	0.0772
-0.800	0.0844	0.0704	0.0721	-0.0094	-0.4195	0.0844	0.0704
-0.850	0.1167	0.0796	0.0675	0.0039	-0.4387	0.1167	0.0796
-0.900	0.1405	0.1010	0.0747	0.0057	-0.4779	0.1405	0.1010
-0.950	*****	0.1321	0.0968	0.0245	-0.5425	*****	0.1321
-0.975	0.2010	0.1775	0.1507	0.0841	-0.3218	0.2010	0.1775
-1.000	0.1948	0.1789	0.1351	-0.0930	*****	0.1948	0.1789
	-0.1701	-0.3936	-0.5858	-0.5692	-0.3265	-0.1701	-0.3936

Medium Radius L.E.
 Run No. = 4, Point No. = 66
 $C_N = 0.170$, $C_M = -0.0220$
 $\alpha = 5.2^\circ$, $M_\infty = 0.599$
 $R_{mac} = 6.0 \times 10^6$

Leading Edge Pressures

● starboard
 ○ port

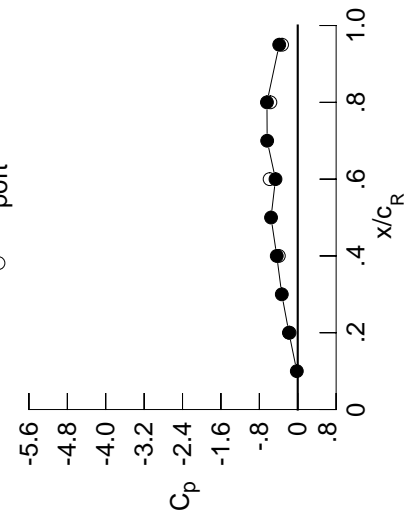

x/c_R	starb'd C_p	port C_p
0.10	-0.0192	*****
0.20	-0.1831	-0.1701
0.30	-0.3322	*****
0.40	-0.4367	-0.3936
0.50	-0.5561	*****
0.60	-0.4634	-0.5858
0.70	-0.6369	*****
0.80	-0.6412	-0.5692
0.90	*****	*****
0.95	-0.3858	-0.3265

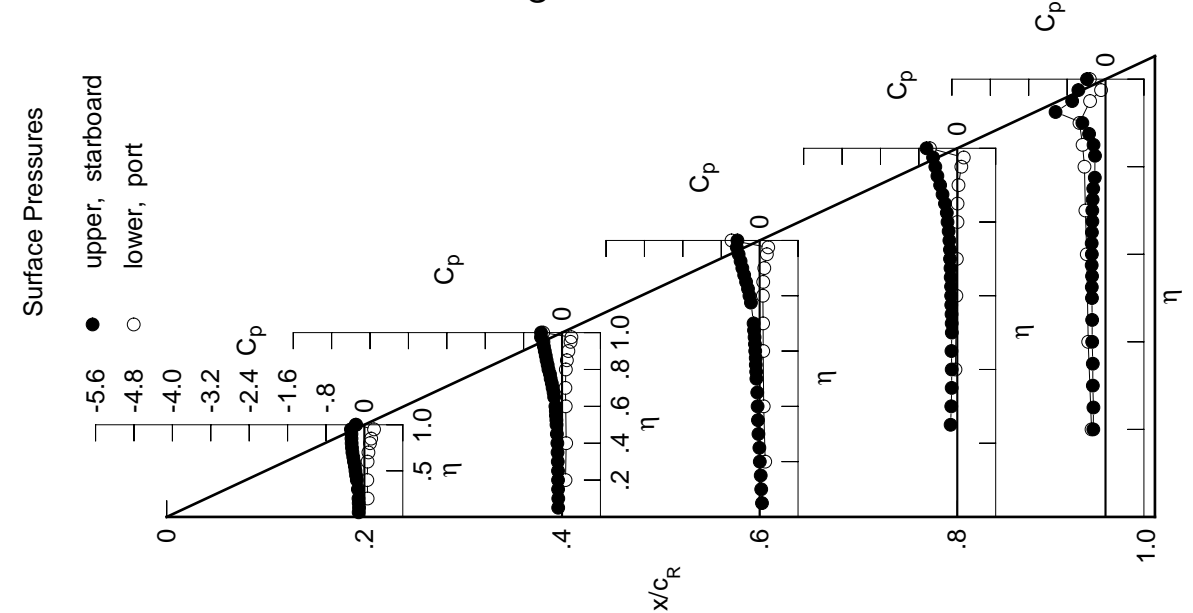

Table D1. Continued.

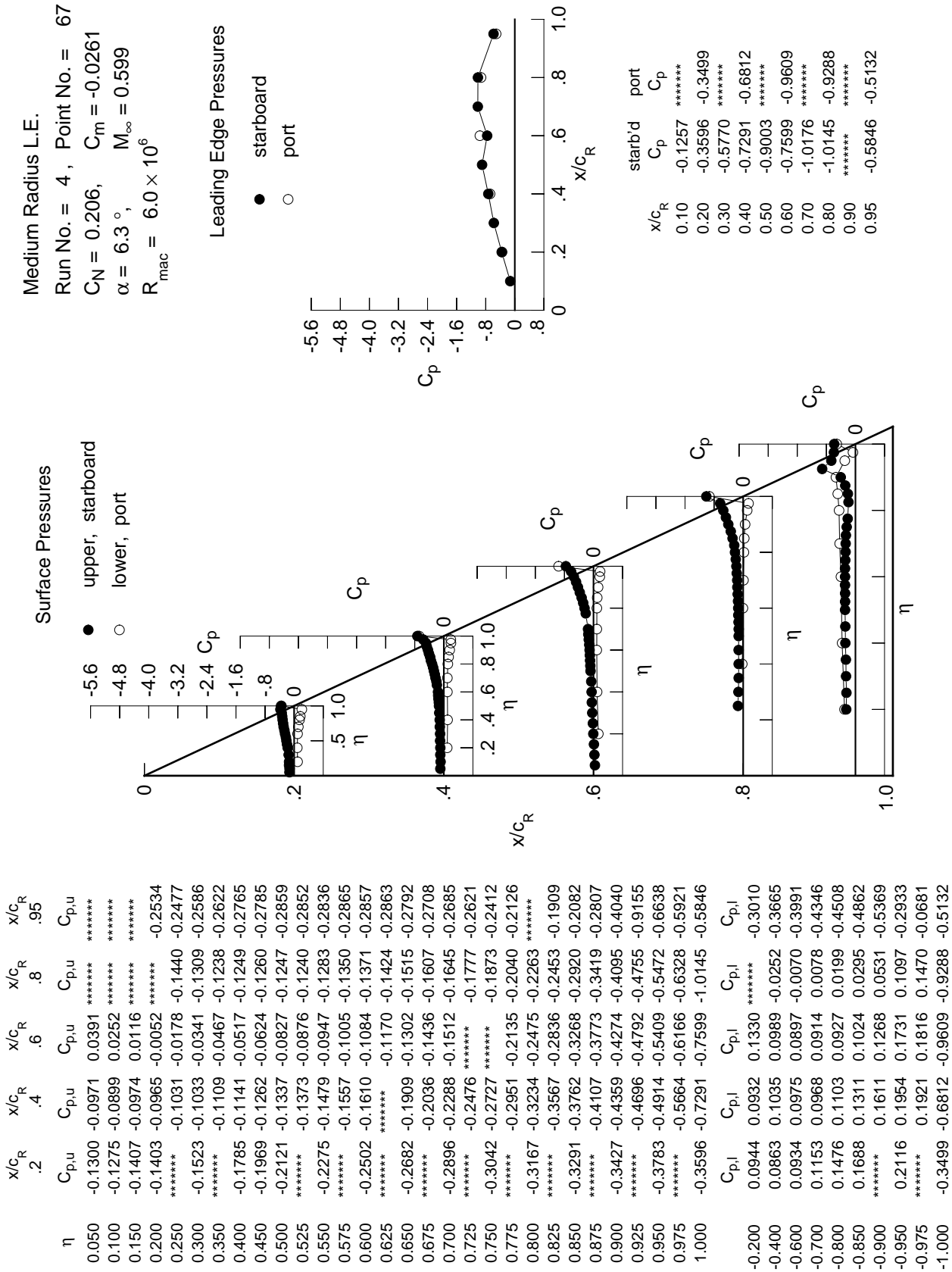
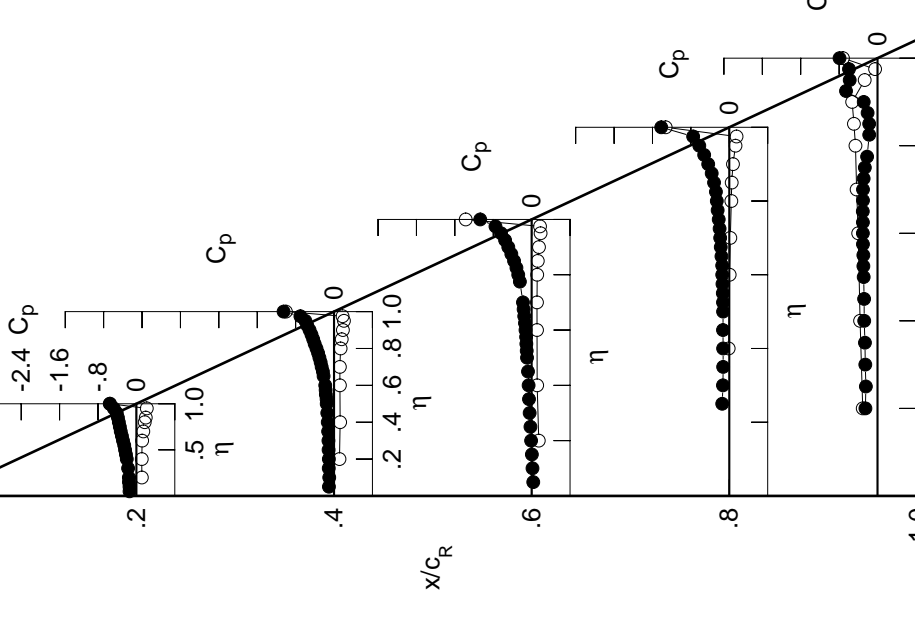
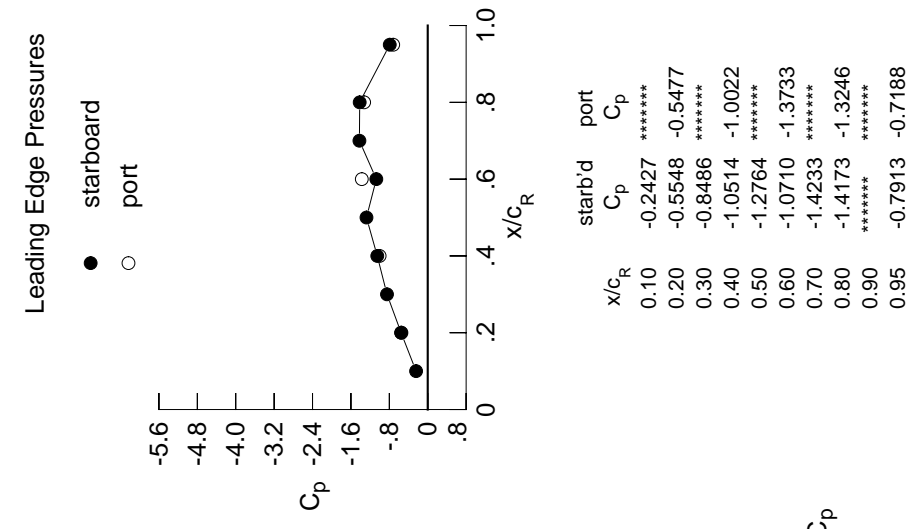

Table D1. Continued.

η	x/c_R	x/c_R	x/c_R	x/c_R	x/c_R	x/c_R	x/c_R	x/c_R	x/c_R
	$C_{p,u}$	$C_{p,u}$	$C_{p,u}$	$C_{p,u}$	$C_{p,u}$	$C_{p,u}$	$C_{p,u}$	$C_{p,u}$	$C_{p,u}$
0.050	-0.1436	-0.1066	0.0335	*****	*****	*****	*****	*****	*****
0.100	-0.1438	-0.1001	0.0179	*****	*****	*****	*****	*****	*****
0.150	-0.1550	-0.1105	0.0045	*****	*****	*****	*****	*****	*****
0.200	-0.1566	-0.1077	-0.0111	*****	*****	*****	*****	*****	*****
0.250	*****	-0.1140	-0.0251	-0.1474	-0.2424	-0.2524	-0.2524	-0.2524	-0.2524
0.300	-0.1728	-0.1171	-0.0412	-0.1322	-0.2545	-0.2545	-0.2545	-0.2545	-0.2545
0.350	*****	-0.1233	-0.0549	-0.1277	-0.2618	-0.2618	-0.2618	-0.2618	-0.2618
0.400	-0.2001	-0.1309	-0.0629	-0.1285	-0.2767	-0.2767	-0.2767	-0.2767	-0.2767
0.450	-0.2177	-0.1404	-0.0761	-0.1311	-0.2792	-0.2792	-0.2792	-0.2792	-0.2792
0.500	-0.2359	-0.1527	-0.0956	-0.1293	-0.2883	-0.2883	-0.2883	-0.2883	-0.2883
0.525	*****	-0.1553	-0.1026	-0.1315	-0.2940	-0.2940	-0.2940	-0.2940	-0.2940
0.550	-0.2536	-0.1708	-0.1100	-0.1350	-0.2955	-0.2955	-0.2955	-0.2955	-0.2955
0.575	*****	-0.1751	-0.1151	-0.1420	-0.3029	-0.3029	-0.3029	-0.3029	-0.3029
0.600	-0.2790	-0.1836	-0.1276	-0.1470	-0.3048	-0.3048	-0.3048	-0.3048	-0.3048
0.625	*****	*****	-0.1390	-0.1483	-0.3044	-0.3044	-0.3044	-0.3044	-0.3044
0.650	-0.3015	-0.2174	-0.1541	-0.1628	-0.3063	-0.3063	-0.3063	-0.3063	-0.3063
0.675	*****	-0.2317	-0.1672	-0.1775	-0.3021	-0.3021	-0.3021	-0.3021	-0.3021
0.700	-0.3258	-0.2572	-0.1811	-0.1894	-0.3021	-0.3021	-0.3021	-0.3021	-0.3021
0.725	*****	-0.2788	*****	-0.2019	-0.2892	-0.2892	-0.2892	-0.2892	-0.2892
0.750	-0.3448	-0.3052	*****	-0.2203	-0.2642	-0.2642	-0.2642	-0.2642	-0.2642
0.775	*****	-0.3317	-0.2450	-0.2423	-0.2164	-0.2164	-0.2164	-0.2164	-0.2164
0.800	-0.3660	-0.3653	-0.2789	-0.2601	*****	*****	*****	*****	*****
0.825	*****	-0.4029	-0.3165	-0.2780	-0.1728	-0.1728	-0.1728	-0.1728	-0.1728
0.850	-0.3849	-0.4342	-0.3661	-0.3176	-0.1737	-0.1737	-0.1737	-0.1737	-0.1737
0.875	*****	-0.4696	-0.4232	-0.3665	-0.2066	-0.2066	-0.2066	-0.2066	-0.2066
0.900	-0.4087	-0.5097	-0.4862	-0.4391	-0.2871	-0.2871	-0.2871	-0.2871	-0.2871
0.925	*****	-0.5579	-0.5525	-0.5232	-0.6559	-0.6559	-0.6559	-0.6559	-0.6559
0.950	-0.4709	-0.5976	-0.6375	-0.6251	-0.5794	-0.5794	-0.5794	-0.5794	-0.5794
0.975	*****	-0.7010	-0.7533	-0.7525	-0.5941	-0.5941	-0.5941	-0.5941	-0.5941
1.000	-0.5548	-1.0514	-1.0710	-1.4173	-0.7913	-0.7913	-0.7913	-0.7913	-0.7913
-0.200	$C_{p,l}$	$C_{p,l}$	$C_{p,l}$	$C_{p,l}$	$C_{p,l}$	$C_{p,l}$	$C_{p,l}$	$C_{p,l}$	$C_{p,l}$
-0.400	0.1139	0.1138	0.1486	*****	-0.3079	-0.3079	-0.3079	-0.3079	-0.3079
-0.600	0.1117	0.1272	0.1151	-0.0128	-0.3632	-0.3632	-0.3632	-0.3632	-0.3632
-0.700	0.1202	0.1226	0.1122	0.0077	-0.4026	-0.4026	-0.4026	-0.4026	-0.4026
-0.800	0.1439	0.1216	0.1116	0.0219	-0.4352	-0.4352	-0.4352	-0.4352	-0.4352
-0.850	0.1739	0.1367	0.1162	0.0423	-0.4591	-0.4591	-0.4591	-0.4591	-0.4591
-0.900	0.1951	0.1598	0.1280	0.0504	-0.4912	-0.4912	-0.4912	-0.4912	-0.4912
-0.950	*****	0.1852	0.1525	0.0766	-0.5283	-0.5283	-0.5283	-0.5283	-0.5283
-0.975	0.2168	0.2061	0.1863	0.1297	-0.2671	-0.2671	-0.2671	-0.2671	-0.2671
-1.000	*****	0.1779	0.1746	0.1509	-0.0505	-0.0505	-0.0505	-0.0505	-0.0505
	-0.5477	-1.0022	-1.3733	-1.3246	-0.7188	-0.7188	-0.7188	-0.7188	-0.7188

Medium Radius L.E.
 Run No. = 4, Point No. = 68
 $C_N = 0.244$, $C_M = -0.0321$
 $\alpha = 7.3^\circ$, $M_\infty = 0.599$
 $R_{mac} = 6.0 \times 10^6$



x/c_R	starb'd C_p	port C_p
0.10	-0.2427	*****
0.20	-0.5548	-0.5477
0.30	-0.8486	*****
0.40	-1.0514	-1.0022
0.50	-1.2764	*****
0.60	-1.0710	-1.3733
0.70	-1.4233	*****
0.80	-1.4173	-1.3246
0.90	*****	*****
0.95	-0.7913	-0.7188

Table D1. Continued.

η	x/c_R .2	x/c_R .4	x/c_R .6	x/c_R .8	x/c_R .95
	$C_{p,u}$	$C_{p,u}$	$C_{p,u}$	$C_{p,u}$	$C_{p,u}$
0.050	-0.1629	-0.1185	0.0213	*****	*****
0.100	-0.1639	-0.1169	0.0070	*****	*****
0.150	-0.1744	-0.1250	-0.0076	*****	*****
0.200	-0.1762	-0.1238	-0.0196	*****	-0.2536
0.250	*****	-0.1316	-0.0373	-0.1569	-0.2431
0.300	-0.1925	-0.1344	-0.0540	-0.1411	-0.2556
0.350	*****	-0.1410	-0.0696	-0.1374	-0.2629
0.400	-0.2201	-0.1508	-0.0781	-0.1367	-0.2753
0.450	-0.2422	-0.1633	-0.0907	-0.1404	-0.2830
0.500	-0.2607	-0.1744	-0.1125	-0.1378	-0.3005
0.525	*****	-0.1846	-0.1188	-0.1404	-0.3079
0.550	-0.2814	-0.1927	-0.1292	-0.1436	-0.3148
0.575	*****	-0.2069	-0.1360	-0.1489	-0.3319
0.600	-0.3115	-0.2147	-0.1520	-0.1529	-0.3450
0.625	*****	*****	-0.1700	-0.1535	-0.3539
0.650	-0.3374	-0.2496	-0.1925	-0.1677	-0.3544
0.675	*****	-0.2654	-0.2092	-0.1897	-0.3563
0.700	-0.3674	-0.2887	-0.2311	-0.2319	-0.3912
0.725	*****	-0.3137	*****	-0.2796	-0.4310
0.750	-0.3925	-0.3429	*****	-0.3219	-0.4659
0.775	*****	-0.3733	-0.2964	-0.3593	-0.4242
0.800	-0.4221	-0.4126	-0.3281	-0.3712	*****
0.825	*****	-0.4540	-0.3566	-0.3693	-0.2538
0.850	-0.4509	-0.4935	-0.4041	-0.3841	-0.2346
0.875	*****	-0.5369	-0.4662	-0.3999	-0.2330
0.900	-0.4879	-0.5876	-0.5402	-0.4463	-0.2285
0.925	*****	-0.6510	-0.6223	-0.5259	-0.2489
0.950	-0.5512	-0.7141	-0.7364	-0.6574	-0.4163
0.975	*****	-0.8583	-0.8993	-0.8450	-0.5806
1.000	-0.7878	-1.4364	-1.3811	-1.8568	-1.0227
	$C_{p,l}$	$C_{p,l}$	$C_{p,l}$	$C_{p,l}$	$C_{p,l}$
-0.200	0.1356	0.1316	0.1657	*****	-0.3111
-0.400	0.1333	0.1446	0.1315	-0.0019	-0.3637
-0.600	0.1461	0.1418	0.1252	0.0247	-0.3765
-0.700	0.1689	0.1446	0.1332	0.0372	-0.4007
-0.800	0.1989	0.1617	0.1387	0.0624	-0.4280
-0.850	0.2164	0.1834	0.1515	0.0719	-0.4635
-0.900	*****	0.2050	0.1738	0.1005	-0.4962
-0.950	0.2143	0.2116	0.1960	0.1445	-0.2334
-0.975	*****	0.1539	0.1573	0.1434	-0.0324
-1.000	-0.7876	-1.3863	-1.8661	-1.7740	-1.0131

Medium Radius L.E.
 Run No. = 4, Point No. = 69
 $C_N = 0.287$, $C_m = -0.0392$
 $\alpha = 8.3^\circ$, $M_\infty = 0.599$
 $R_{mac} = 6.0 \times 10^6$

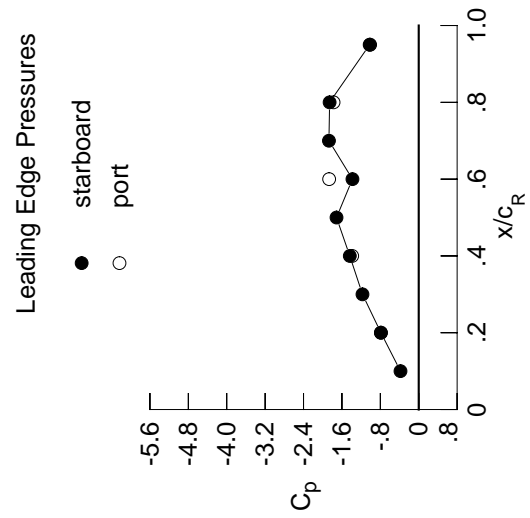

x/c_R	starb'd C_p	port C_p
0.10	-0.3797	*****
0.20	-0.7878	-0.7876
0.30	-1.1717	*****
0.40	-1.4364	-1.3863
0.50	-1.7129	*****
0.60	-1.3811	-1.8661
0.70	-1.8707	*****
0.80	-1.8568	-1.7740
0.90	*****	*****
0.95	-1.0227	-1.0131

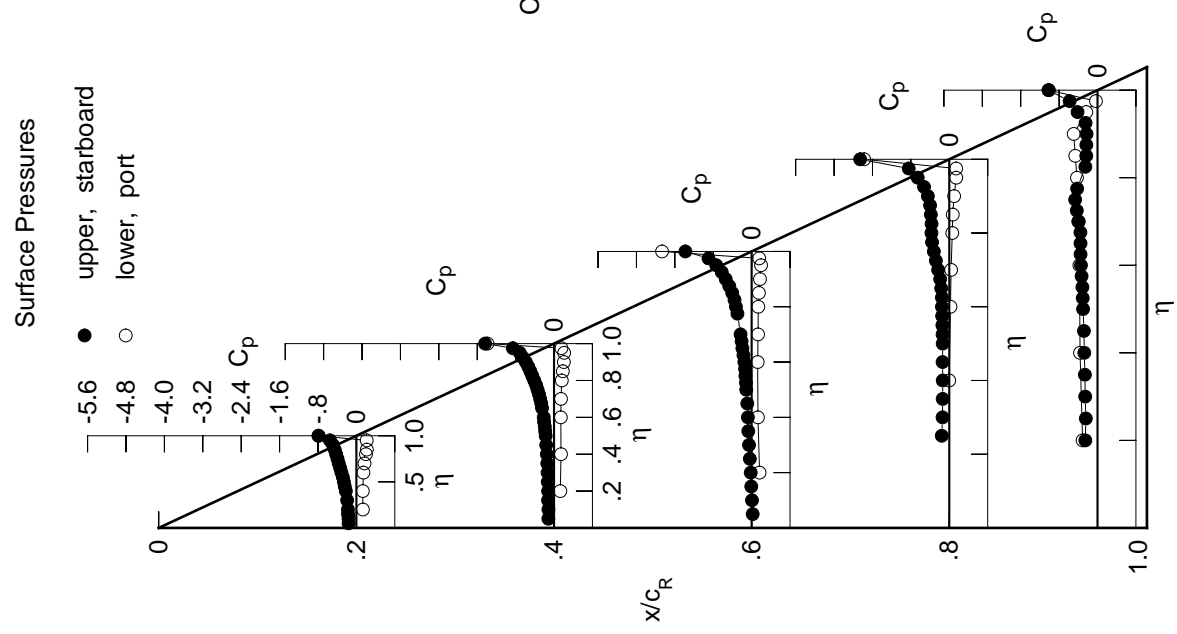
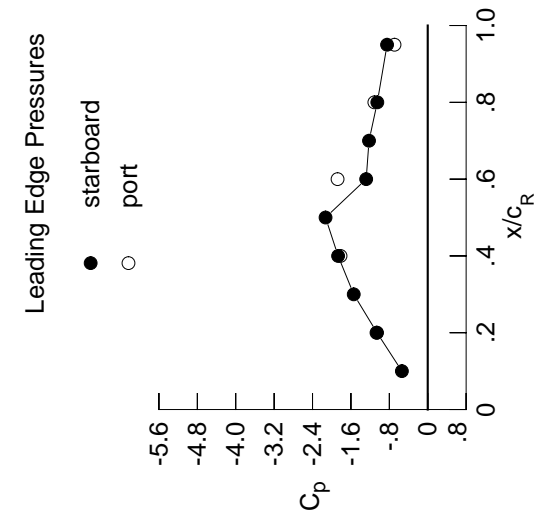

Table D1. Continued.

η	x/c_R	x/c_R	x/c_R	x/c_R	x/c_R	x/c_R	x/c_R	x/c_R	x/c_R
	$C_{p,u}$	$C_{p,u}$	$C_{p,u}$	$C_{p,u}$	$C_{p,u}$	$C_{p,u}$	$C_{p,u}$	$C_{p,i}$	$C_{p,i}$
0.050	-0.1807	-0.1359	0.0094	*****	*****	*****	*****	-0.3175	*****
0.100	-0.1824	-0.1342	-0.0063	*****	*****	*****	*****	-0.3680	*****
0.150	-0.1937	-0.1411	-0.0207	*****	*****	*****	*****	-0.3790	*****
0.200	-0.1966	-0.1405	-0.0369	*****	*****	*****	*****	-0.4046	*****
0.250	*****	-0.1482	-0.0524	-0.1696	-0.2463	*****	*****	-0.4036	*****
0.300	-0.2145	-0.1522	-0.0702	-0.1555	-0.2537	*****	*****	-0.4258	*****
0.350	*****	-0.1630	-0.0838	-0.1500	-0.2613	*****	*****	-0.4515	*****
0.400	-0.2464	-0.1731	-0.0903	-0.1513	-0.2725	*****	*****	-0.2015	*****
0.450	-0.2662	-0.1879	-0.1043	-0.1552	-0.2797	*****	*****	-0.0218	*****
0.500	-0.2882	-0.2043	-0.1263	-0.1493	-0.3049	*****	*****	-1.1121	*****
0.525	*****	-0.2141	-0.1353	-0.1494	-0.3169	*****	*****	-1.8782	*****
0.550	-0.3102	-0.2288	-0.1460	-0.1498	-0.3210	*****	*****	-0.6920	*****
0.575	*****	-0.2413	-0.1533	-0.1525	-0.3404	*****	*****	-0.8469	*****
0.600	-0.3447	-0.2533	-0.1731	-0.1539	-0.3392	*****	*****	-1.0567	*****
0.625	*****	*****	-0.2017	-0.1867	-0.2803	*****	*****	-1.8169	*****
0.650	-0.3802	-0.2910	-0.2455	-0.2750	-0.2780	*****	*****	-1.0671	*****
0.675	*****	-0.3110	-0.2869	-0.3389	-0.2917	*****	*****	-0.6668	*****
0.700	-0.4093	-0.3280	-0.3284	-0.2574	-0.3232	*****	*****	-0.5208	*****
0.725	*****	-0.3513	*****	-0.2376	-0.3508	*****	*****	*****	*****
0.750	-0.4418	-0.3819	*****	-0.2342	-0.3806	*****	*****	-0.4784	*****
0.775	*****	-0.4148	-0.4008	-0.2346	-0.4195	*****	*****	*****	*****
0.800	-0.4784	-0.4570	-0.4121	-0.2377	*****	*****	*****	-0.5726	*****
0.825	*****	-0.5049	-0.4141	-0.3040	-0.4901	*****	*****	*****	*****
0.850	-0.5208	-0.5493	-0.4329	-0.5695	-0.4575	*****	*****	-0.6668	*****
0.875	*****	-0.6088	-0.4747	-0.7069	-0.4708	*****	*****	*****	*****
0.900	-0.5726	-0.6674	-0.5424	-0.7890	-0.5856	*****	*****	-0.6668	*****
0.925	*****	-0.7476	-0.6763	-0.9173	-0.7871	*****	*****	*****	*****
0.950	-0.6668	-0.8289	-1.0477	-0.9350	-0.6928	*****	*****	*****	*****
0.975	*****	-1.0124	-1.3405	-0.8965	-0.6780	*****	*****	*****	*****
1.000	-1.0567	-1.8672	-1.2822	-1.0506	-0.8469	*****	*****	*****	*****
-0.200	$C_{p,i}$	$C_{p,i}$	$C_{p,i}$	$C_{p,i}$	$C_{p,i}$	$C_{p,i}$	$C_{p,i}$	$C_{p,i}$	$C_{p,i}$
-0.400	0.1583	0.1533	0.1803	*****	-0.3175	*****	*****	*****	*****
-0.600	0.1570	0.1631	0.1492	0.0108	-0.3680	*****	*****	*****	*****
-0.700	0.1734	0.1635	0.1476	0.0364	-0.3790	*****	*****	*****	*****
-0.800	0.1952	0.1682	0.1528	0.0537	-0.4046	*****	*****	*****	*****
-0.850	0.2226	0.1874	0.1622	0.0798	-0.4036	*****	*****	*****	*****
-0.900	0.2349	0.2066	0.1754	0.0924	-0.4258	*****	*****	*****	*****
-0.950	*****	0.2226	0.1954	0.1218	-0.4515	*****	*****	*****	*****
-0.975	*****	0.2045	0.2082	0.2031	0.1586	-0.2015	*****	*****	*****
-1.000	*****	0.1199	0.1419	0.1481	-0.0218	*****	*****	*****	*****
		-1.0671	-1.8169	-1.8782	-1.1121	-0.6920	*****	*****	*****

Medium Radius L.E.
 Run No. = 4, Point No. = 70
 $C_N = 0.344$, $C_M = -0.0530$
 $\alpha = 9.3^\circ$, $M_\infty = 0.599$
 $R_{mac} = 6.0 \times 10^6$



x/c_R	starb'd C_p	port C_p
0.10	-0.5381	*****
0.20	-1.0567	-1.0671
0.30	-1.5415	*****
0.40	-1.8672	-1.8169
0.50	-2.1291	*****
0.60	-1.2822	-1.8782
0.70	-1.2232	*****
0.80	-1.0506	-1.1121
0.90	*****	*****
0.95	-0.8469	-0.6920

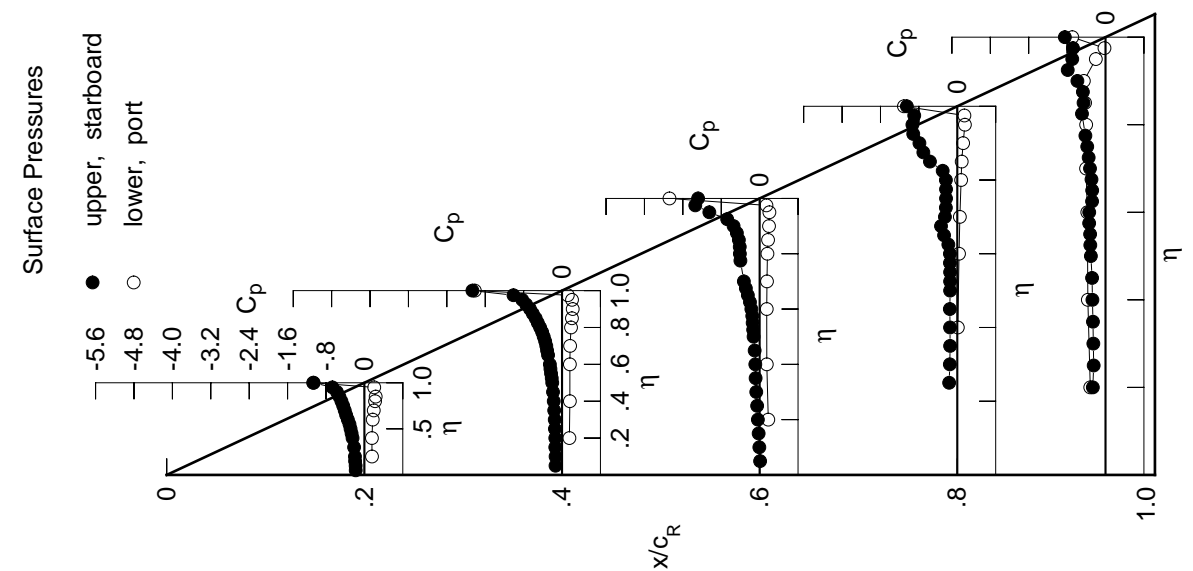
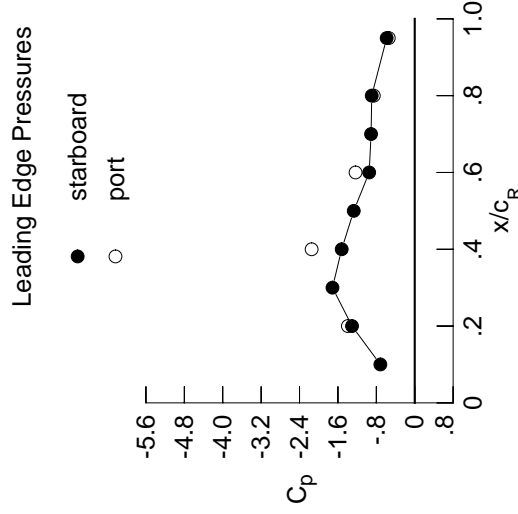

Table D1. Continued.

η	x/c_R .2	x/c_R .4	x/c_R .6	x/c_R .8	x/c_R .95
	$C_{p,u}$	$C_{p,u}$	$C_{p,u}$	$C_{p,u}$	$C_{p,u}$
0.050	-0.1968	-0.1570	-0.0062	*****	*****
0.100	-0.1999	-0.1504	-0.0245	*****	*****
0.150	-0.2130	-0.1610	-0.0370	*****	*****
0.200	-0.2165	-0.1604	-0.0537	*****	-0.2615
0.250	*****	-0.1700	-0.0674	-0.1804	-0.2475
0.300	-0.2356	-0.1739	-0.0889	-0.1641	-0.2643
0.350	*****	-0.1828	-0.0997	-0.1561	-0.2965
0.400	-0.2738	-0.2004	-0.1099	-0.1585	-0.3317
0.450	-0.2950	-0.2252	-0.1306	-0.1863	-0.3141
0.500	-0.3163	-0.2532	-0.1949	-0.1963	-0.2840
0.525	*****	-0.2696	-0.2163	-0.1827	-0.2885
0.550	-0.3427	-0.2877	-0.2328	-0.1789	-0.2983
0.575	*****	-0.3054	-0.2257	-0.1790	-0.3121
0.600	-0.3784	-0.3135	-0.2269	-0.1811	-0.3210
0.625	*****	*****	-0.2338	-0.1881	-0.3319
0.650	-0.4160	-0.3486	-0.2323	-0.1948	-0.3397
0.675	*****	-0.3587	-0.2345	-0.1957	-0.3607
0.700	-0.4542	-0.3703	-0.2419	-0.2044	-0.4013
0.725	*****	-0.3855	*****	-0.2278	-0.4670
0.750	-0.4912	-0.4097	*****	-0.3182	-0.5076
0.775	*****	-0.4351	-0.3398	-0.5072	-0.5089
0.800	-0.5355	-0.4794	-0.4685	-0.7206	*****
0.825	*****	-0.5277	-0.6171	-0.8107	-0.4370
0.850	-0.5888	-0.5757	-0.7306	-0.7558	-0.4054
0.875	*****	-0.6601	-0.8671	-0.6915	-0.4073
0.900	-0.6521	-0.8310	-1.0339	-0.6684	-0.4582
0.925	*****	-1.0887	-1.1183	-0.7180	-0.5804
0.950	-0.7297	-1.2983	-1.0891	-0.8549	-0.5880
0.975	*****	-1.3788	-1.0521	-0.8126	-0.5012
1.000	-1.3063	-1.5215	-0.9486	-0.8958	-0.5850
	$C_{p,l}$	$C_{p,l}$	$C_{p,l}$	$C_{p,l}$	$C_{p,l}$
-0.200	0.1816	0.1756	0.1978	*****	-0.3149
-0.400	0.1845	0.1897	0.1685	0.0265	-0.3765
-0.600	0.1993	0.1878	0.1632	0.0555	-0.3855
-0.700	0.2219	0.1953	0.1751	0.0666	-0.3857
-0.800	0.2446	0.2142	0.1850	0.0977	-0.3885
-0.850	0.2531	0.2307	0.1974	0.1100	-0.4193
-0.900	*****	0.2390	0.2155	0.1390	-0.4432
-0.950	0.1907	0.2060	0.2125	0.1680	-0.1905
-0.975	*****	0.0866	0.1411	0.1504	-0.0171
-1.000	-1.3931	-2.1484	-1.2328	-0.8531	-0.5409

Medium Radius L.E.
 Run No. = 4, Point No. = 71
 $C_N = 0.395$, $C_M = -0.0588$
 $\alpha = 10.3^\circ$, $M_\infty = 0.599$
 $R_{mac} = 6.0 \times 10^6$



x/c_R	starbd C_p	port C_p
0.10	-0.7162	*****
0.20	-1.3063	-1.3931
0.30	-1.7139	*****
0.40	-1.5215	-2.1484
0.50	-1.2702	*****
0.60	-0.9486	-1.2328
0.70	-0.9092	*****
0.80	-0.8958	-0.8531
0.90	*****	*****
0.95	-0.5850	-0.5409

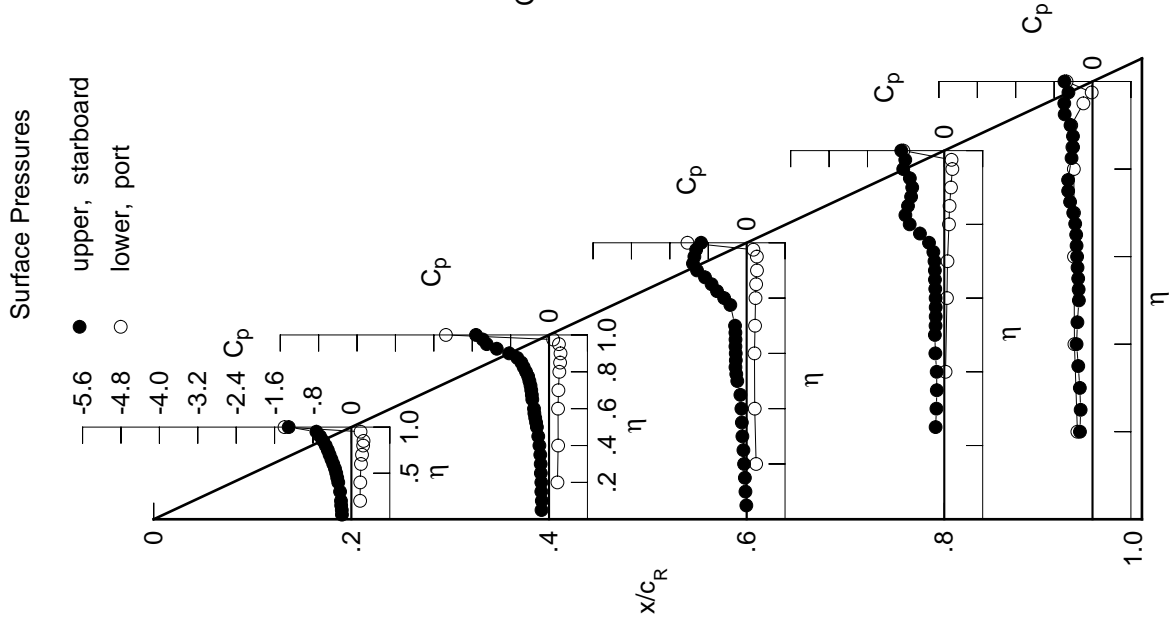

Table D1. Continued.

η	x/c_R	x/c_R	x/c_R	x/c_R	x/c_R	x/c_R	x/c_R
	$C_{p,u}$	$C_{p,u}$	$C_{p,u}$	$C_{p,u}$	$C_{p,u}$	$C_{p,l}$	$C_{p,l}$
0.050	-0.2156	-0.1750	-0.0253	*****	*****	0.2160	-0.3245
0.100	-0.2184	-0.1741	-0.0420	*****	*****	0.1848	-0.3780
0.150	-0.2355	-0.1831	-0.0566	*****	*****	0.1823	-0.3782
0.200	-0.2440	-0.1820	-0.0758	*****	*****	0.1937	-0.3902
0.250	*****	-0.1889	-0.0895	-0.1897	-0.2538	0.2053	-0.4143
0.300	-0.2617	-0.1948	-0.1073	-0.1762	-0.2886	0.2117	-0.4396
0.350	*****	-0.2052	-0.1196	-0.1737	-0.3021	0.2205	-0.4511
0.400	-0.3031	-0.2242	-0.1532	-0.1925	-0.2892	0.2388	-0.4866
0.450	-0.3251	-0.2707	-0.1945	-0.1809	-0.2767	0.2536	-0.5141
0.500	-0.3502	-0.3266	-0.2106	-0.1727	-0.3094	0.2560	-0.5141
0.525	*****	-0.3329	-0.1991	-0.1707	-0.3199	0.2309	-0.4511
0.550	-0.3766	-0.3205	-0.2011	-0.1762	-0.3361	0.2075	-0.4866
0.575	*****	-0.3150	-0.2020	-0.1838	-0.3564	0.1745	-0.5141
0.600	-0.4142	-0.3157	-0.2140	-0.1963	-0.3699	0.1329	-0.5141
0.625	*****	*****	-0.2240	-0.2110	-0.3959	0.0745	-0.5141
0.650	-0.4558	-0.3542	-0.2498	-0.2482	-0.4300	-0.15830	-0.7709
0.675	*****	-0.3860	-0.2691	-0.3089	-0.4762	-0.10611	-0.4433
0.700	-0.4987	-0.4092	-0.2892	-0.3875	-0.5392	-0.8095	-0.7709
0.725	*****	-0.4267	*****	-0.4993	-0.5929	*****	*****
0.750	-0.5427	-0.4440	*****	-0.6166	-0.6099	-0.9006	*****
0.775	*****	-0.4443	-0.6317	-0.7386	-0.5864	-1.5698	-1.7488
0.800	-0.5966	-0.4537	-0.7845	-0.8295	*****	-1.5944	*****
0.825	*****	-0.4926	-0.8474	-0.8503	-0.4936	-1.4057	-1.5830
0.850	-0.6619	-0.7089	-0.8435	-0.8013	-0.4606	-1.1942	*****
0.875	*****	-1.1549	-0.8924	-0.7406	-0.4404	-0.9311	-1.0611
0.900	-0.7363	-1.3526	-1.0153	-0.7104	-0.4283	-0.8821	*****
0.925	*****	-1.3950	-1.1247	-0.7195	-0.4095	-0.8095	-0.7709
0.950	-0.8658	-1.3638	-1.0934	-0.8031	-0.3657	*****	*****
0.975	*****	-1.3299	-1.0349	-0.7681	-0.3269	-0.4223	*****
1.000	-1.5698	-1.4057	-0.9311	-0.8095	-0.4223		

Medium Radius L.E.
 Run No. = 4, Point No. = 72
 $C_N = 0.453$, $C_M = -0.0718$
 $\alpha = 11.3^\circ$, $M_\infty = 0.599$
 $R_{mac} = 6.0 \times 10^6$

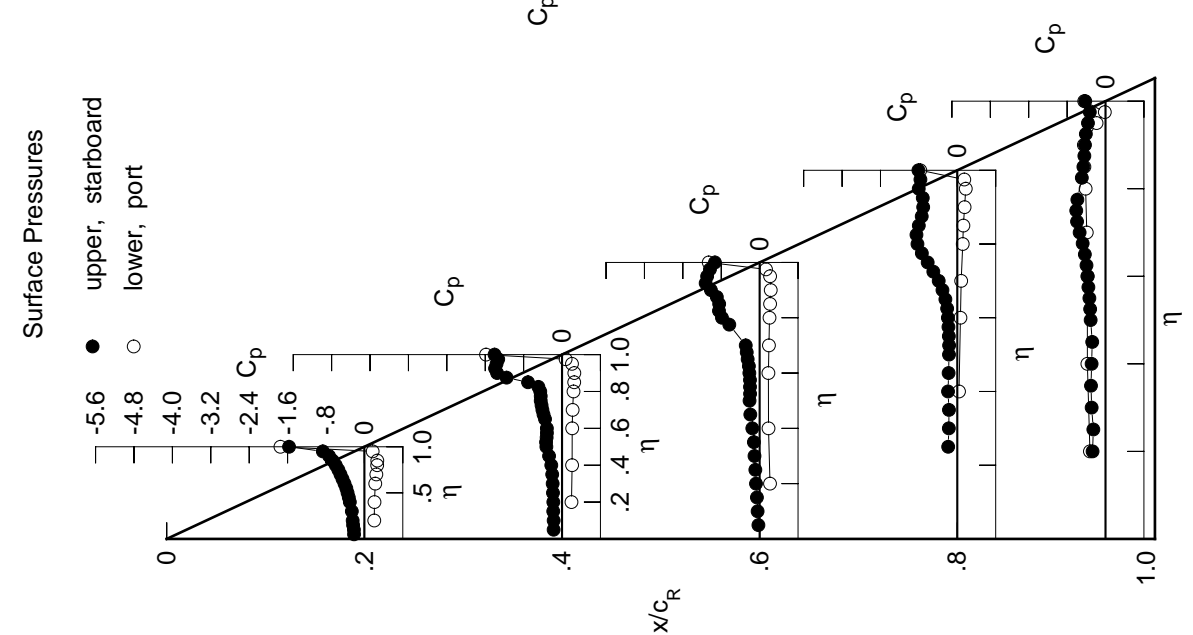

Table D1. Continued.

η	x/c_R .2	x/c_R .4	x/c_R .6	x/c_R .8	x/c_R .95
	$C_{p,u}$	$C_{p,u}$	$C_{p,u}$	$C_{p,u}$	$C_{p,u}$
0.050	-0.2383	-0.2049	-0.0428	*****	*****
0.100	-0.2406	-0.2017	-0.0629	*****	*****
0.150	-0.2641	-0.2102	-0.0757	*****	*****
0.200	-0.2704	-0.2088	-0.0925	*****	-0.2262
0.250	*****	-0.2143	-0.1056	-0.2006	-0.2386
0.300	-0.2996	-0.2224	-0.1279	-0.1829	-0.2853
0.350	*****	-0.2371	-0.1676	-0.1911	-0.2791
0.400	-0.3428	-0.2958	-0.1786	-0.1805	-0.2792
0.450	-0.3643	-0.3457	-0.1733	-0.1767	-0.2923
0.500	-0.3905	-0.3022	-0.2025	-0.1681	-0.3264
0.525	*****	-0.2957	-0.2059	-0.1624	-0.3437
0.550	-0.4201	-0.3063	-0.2171	-0.1620	-0.3532
0.575	*****	-0.3043	-0.2197	-0.1702	-0.3744
0.600	-0.4566	-0.3126	-0.2413	-0.1914	-0.3946
0.625	*****	*****	-0.2449	-0.2301	-0.4422
0.650	-0.5008	-0.3662	-0.2933	-0.3262	-0.5283
0.675	*****	-0.4101	-0.3616	-0.4869	-0.6335
0.700	-0.5482	-0.4559	-0.4791	-0.6737	-0.7587
0.725	*****	-0.4941	*****	-0.8418	-0.8399
0.750	-0.5998	-0.5488	*****	-0.9520	-0.8459
0.775	*****	-0.6392	-1.0086	-1.0002	-0.7810
0.800	-0.6579	-0.8171	-1.0864	-0.9941	*****
0.825	*****	-1.0627	-1.0889	-0.9274	-0.5329
0.850	-0.7288	-1.2613	-1.0401	-0.8370	-0.4725
0.875	*****	-1.3559	-1.0177	-0.7784	-0.4375
0.900	-0.8543	-1.3621	-1.0141	-0.7495	-0.4128
0.925	*****	-1.3225	-1.0188	-0.7185	-0.3950
0.950	-1.3664	-1.2773	-0.9907	-0.7264	-0.3280
0.975	*****	-1.2462	-0.9396	-0.6950	-0.2880
1.000	-1.7214	-1.2911	-0.8496	-0.7198	-0.3550
	$C_{p,l}$	$C_{p,l}$	$C_{p,l}$	$C_{p,l}$	$C_{p,l}$
-0.200	0.2352	0.2188	0.2333	*****	-0.3334
-0.400	0.2381	0.2338	0.2023	0.0508	-0.3927
-0.600	0.2539	0.2361	0.2027	0.0800	-0.3815
-0.700	0.2737	0.2441	0.2136	0.0942	-0.4106
-0.800	0.2859	0.2607	0.2223	0.1247	-0.4354
-0.850	0.2828	0.2725	0.2345	0.1371	-0.4551
-0.900	*****	0.2663	0.2442	0.1653	-0.4556
-0.950	0.1498	0.2039	0.2183	0.1802	-0.1795
-0.975	*****	0.0518	0.1213	0.1372	-0.0138
-1.000	-2.1030	-1.3968	-0.9351	-0.7268	-0.3986

Medium Radius L.E.
 Run No. = 4, Point No. = 73
 $C_N = 0.511$, $C_m = -0.0788$
 $\alpha = 12.4^\circ$, $M_\infty = 0.599$
 $R_{mac} = 6.0 \times 10^6$

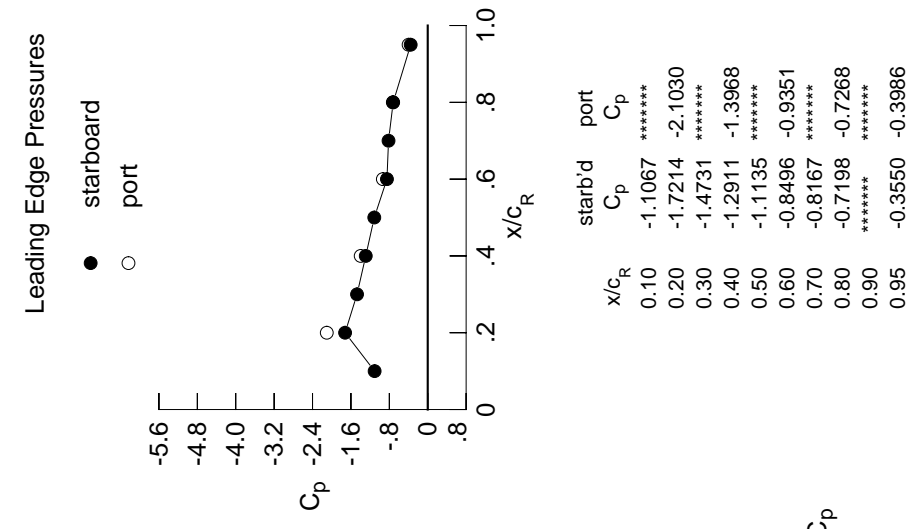
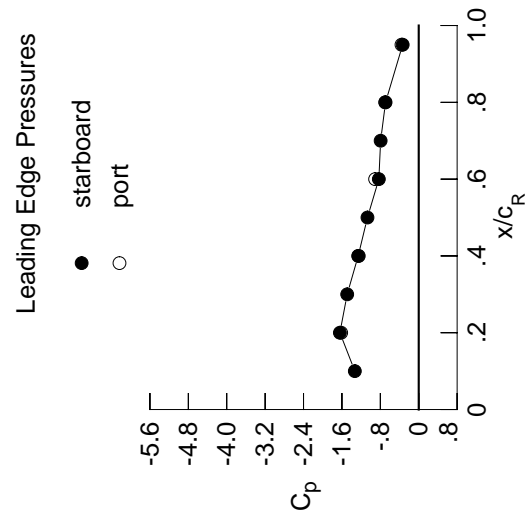

Table D1. Continued.

η	x/c_R	$C_{p,u}$	x/c_R	$C_{p,u}$	x/c_R	$C_{p,u}$	x/c_R	$C_{p,u}$	x/c_R	$C_{p,u}$
0.050	0.2	-0.2659	0.4	-0.2360	0.6	-0.0615	0.8	0.2500	0.95	0.3211
0.100		-0.2636		-0.2298		-0.0773		0.2667		0.3817
0.150		-0.2889		-0.2398		-0.0943		0.2808		0.3909
0.200		-0.3036		-0.2394		-0.1109		0.2977		0.4388
0.250		*****		-0.2424		-0.1246		0.3055		0.4557
0.300		-0.3356		-0.2570		-0.1690		0.2977		0.4656
0.350		*****		-0.3041		-0.1819		0.2751		0.4542
0.400		-0.3881		-0.3359		-0.1778		0.1415		0.1714
0.450		-0.4052		-0.3261		-0.1746		0.0300		0.1013
0.500		-0.4303		-0.3232		-0.1937		-0.1612		-0.3592
0.525		*****		-0.3275		-0.1928		-1.2499		-0.6988
0.550		-0.4614		-0.3307		-0.2020		-0.9091		-0.3592
0.575		*****		-0.3311		-0.2012		-0.8309		-0.9091
0.600		-0.4941		-0.3296		-0.2297		-0.7938		-0.6915
0.625		*****		*****		-0.2517		-0.6915		*****
0.650		-0.5278		-0.3575		-0.3565		-0.3346		-0.3592
0.675		*****		-0.3857		-0.5160		-0.1612		-0.6988
0.700		-0.5730		-0.4536		-0.7524		-0.8309		-0.9091
0.725		*****		-0.6048		*****		-1.0681		*****
0.750		-0.6071		-0.8880		*****		-1.2499		-0.6988
0.775		*****		-1.1317		-1.3145		-1.1974		-0.7062
0.800		-0.6385		-1.2897		-1.3305		-1.0631		*****
0.825		*****		-1.3925		-1.2540		-0.8903		-0.4767
0.850		-0.9911		-1.4535		-1.1209		-0.8129		-0.4534
0.875		*****		-1.4487		-1.0616		-0.7910		-0.4371
0.900		-1.3992		-1.3962		-1.0216		-0.7696		-0.4272
0.925		*****		-1.3342		-0.9873		-0.7155		-0.4159
0.950		-1.5424		-1.2772		-0.9475		-0.7076		-0.3397
0.975		*****		-1.2443		-0.9096		-0.6906		-0.2964
1.000		-1.6426		-1.2613		-0.8309		-0.6915		-0.3346
-0.200		0.2623		0.2434		0.2500		0.2500		-0.3211
-0.400		0.2667		0.2615		0.2208		0.0670		-0.3817
-0.600		0.2808		0.2582		0.2203		0.0916		-0.3909
-0.700		0.2977		0.2666		0.2317		0.1108		-0.4388
-0.800		0.3055		0.2831		0.2411		0.1382		-0.4557
-0.850		0.2977		0.2901		0.2522		0.1527		-0.4656
-0.900		*****		0.2751		0.2564		0.1782		-0.4542
-0.950		0.1415		0.1969		0.2176		0.1845		-0.1714
-0.975		*****		0.0300		0.1033		0.1324		-0.0113
-1.000		-1.6162		-1.2499		-0.9091		-0.6988		-0.3592

Medium Radius L.E.
 Run No. = 4, Point No. = 74
 $C_N = 0.568$, $C_m = -0.0870$
 $\alpha = 13.4^\circ$, $M_\infty = 0.599$
 $R_{mac} = 6.0 \times 10^6$



Leading Edge Pressures

● starboard
 ○ port

x/c_R	starb'd C_p	port C_p
0.10	-1.3310	*****
0.20	-1.6426	-1.6162
0.30	-1.4906	*****
0.40	-1.2613	-1.2499
0.50	-1.0681	*****
0.60	-0.8309	-0.9091
0.70	-0.7938	*****
0.80	-0.6915	-0.6988
0.90	*****	*****
0.95	-0.3346	-0.3592

Table D1. Continued.

η	x/c_R	$C_{p,u}$	x/c_R	$C_{p,u}$	x/c_R	$C_{p,u}$	x/c_R	$C_{p,u}$	x/c_R	$C_{p,u}$
0.050	0.2929	-0.2649	-0.0783	0.0783	0.0783	0.0783	0.0783	0.0783	0.0783	0.0783
0.100	-0.2861	-0.2609	-0.0978	0.0978	0.0978	0.0978	0.0978	0.0978	0.0978	0.0978
0.150	-0.3146	-0.2668	-0.1083	0.1083	0.1083	0.1083	0.1083	0.1083	0.1083	0.1083
0.200	-0.3386	-0.2633	-0.1261	0.1261	0.1261	0.1261	0.1261	0.1261	0.1261	0.1261
0.250	0.3069	-0.2891	-0.1581	-0.2264	-0.2264	-0.2264	-0.2264	-0.2264	-0.2264	-0.2264
0.300	-0.3808	-0.3365	-0.1742	-0.2088	-0.2088	-0.2088	-0.2088	-0.2088	-0.2088	-0.2088
0.350	0.2663	-0.3062	-0.1803	-0.1966	-0.1966	-0.1966	-0.1966	-0.1966	-0.1966	-0.1966
0.400	-0.4339	-0.3088	-0.1885	-0.1928	-0.1928	-0.1928	-0.1928	-0.1928	-0.1928	-0.1928
0.450	-0.4402	-0.3244	-0.1913	-0.1875	-0.1875	-0.1875	-0.1875	-0.1875	-0.1875	-0.1875
0.500	-0.4493	-0.3419	-0.2069	-0.1777	-0.1777	-0.1777	-0.1777	-0.1777	-0.1777	-0.1777
0.525	0.3918	-0.3511	-0.2071	-0.1815	-0.1815	-0.1815	-0.1815	-0.1815	-0.1815	-0.1815
0.550	-0.4658	-0.3645	-0.2126	-0.1949	-0.1949	-0.1949	-0.1949	-0.1949	-0.1949	-0.1949
0.575	0.4631	-0.3673	-0.2208	-0.2372	-0.2372	-0.2372	-0.2372	-0.2372	-0.2372	-0.2372
0.600	-0.5019	-0.3667	-0.2681	-0.3055	-0.3055	-0.3055	-0.3055	-0.3055	-0.3055	-0.3055
0.625	0.6449	0.3444	-0.3444	-0.4350	-0.4350	-0.4350	-0.4350	-0.4350	-0.4350	-0.4350
0.650	-0.5375	-0.4335	-0.5372	-0.6270	-0.6270	-0.6270	-0.6270	-0.6270	-0.6270	-0.6270
0.675	0.8778	-0.5583	-0.7871	-0.8722	-0.8722	-0.8722	-0.8722	-0.8722	-0.8722	-0.8722
0.700	-0.5409	-0.8342	-1.0689	-1.1020	-1.1020	-1.1020	-1.1020	-1.1020	-1.1020	-1.1020
0.725	0.8967	-1.1552	0.8967	-1.2604	-1.2604	-1.2604	-1.2604	-1.2604	-1.2604	-1.2604
0.750	0.6888	-1.4051	0.6888	-1.2735	-1.2735	-1.2735	-1.2735	-1.2735	-1.2735	-1.2735
0.775	-0.4839	-1.5058	-1.5178	-1.1131	-1.1131	-1.1131	-1.1131	-1.1131	-1.1131	-1.1131
0.800	0.8872	-1.1567	-1.5468	-1.4148	-0.8872	0.8872	0.8872	0.8872	0.8872	0.8872
0.825	0.4533	0.825	-1.5409	-1.2142	-0.8112	-0.4533	-0.4533	-0.4533	-0.4533	-0.4533
0.850	-0.4313	-1.5507	-1.5003	-1.0859	-0.8061	-0.4313	-0.4313	-0.4313	-0.4313	-0.4313
0.875	0.4204	0.4204	-1.4228	-1.0647	-0.8059	-0.4204	-0.4204	-0.4204	-0.4204	-0.4204
0.900	-0.4125	-1.5750	-1.3552	-1.0401	-0.7759	-0.4125	-0.4125	-0.4125	-0.4125	-0.4125
0.925	0.4015	0.4015	-1.3047	-0.9801	-0.7341	-0.4015	-0.4015	-0.4015	-0.4015	-0.4015
0.950	-0.3340	-1.5184	-1.2521	-0.9370	-0.7248	-0.3340	-0.3340	-0.3340	-0.3340	-0.3340
0.975	0.2882	0.2882	-1.2162	-0.9051	-0.7061	-0.2882	-0.2882	-0.2882	-0.2882	-0.2882
1.000	-0.3224	-1.5877	-1.2284	-0.8173	-0.6973	-0.3224	-0.3224	-0.3224	-0.3224	-0.3224
-0.200	0.3175	0.2872	0.2670	0.2648	0.3175	0.3175	0.3175	0.3175	0.3175	0.3175
-0.400	0.3788	0.2937	0.2768	0.2397	0.0767	0.3788	0.3788	0.3788	0.3788	0.3788
-0.600	0.4152	0.3096	0.2805	0.2371	0.1048	0.4152	0.4152	0.4152	0.4152	0.4152
-0.700	0.4710	0.3257	0.2887	0.2494	0.1256	0.4710	0.4710	0.4710	0.4710	0.4710
-0.800	0.4770	0.3252	0.3022	0.2582	0.1527	0.4770	0.4770	0.4770	0.4770	0.4770
-0.850	0.4769	0.3109	0.3060	0.2674	0.1661	0.4769	0.4769	0.4769	0.4769	0.4769
-0.900	0.4546	0.2853	0.2853	0.2656	0.1890	0.4546	0.4546	0.4546	0.4546	0.4546
-0.950	0.1649	0.1229	0.1911	0.2124	0.1864	0.1649	0.1649	0.1649	0.1649	0.1649
-0.975	0.0118	0.0060	0.0060	0.0825	0.1196	0.0118	0.0118	0.0118	0.0118	0.0118
-1.000	-0.3370	-1.5913	-1.2185	-0.9104	-0.6979	-0.3370	-0.3370	-0.3370	-0.3370	-0.3370

Medium Radius L.E.
 Run No. = 4, Point No. = 75
 $C_N = 0.616$, $C_m = -0.0881$
 $\alpha = 14.4^\circ$, $M_\infty = 0.599$
 $R_{mac} = 6.0 \times 10^6$

Leading Edge Pressures

● starboard
 ○ port

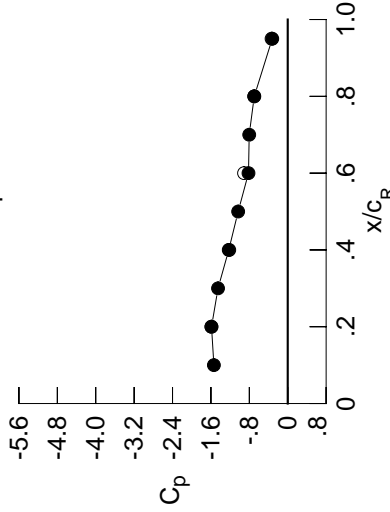

x/c_R	starb'd C_p	port C_p
0.10	-1.5382	*****
0.20	-1.5877	-1.5913
0.30	-1.4522	*****
0.40	-1.2284	-1.2185
0.50	-1.0326	*****
0.60	-0.8173	-0.9104
0.70	-0.8027	*****
0.80	-0.6973	-0.6979
0.90	*****	*****
0.95	-0.3224	-0.3370

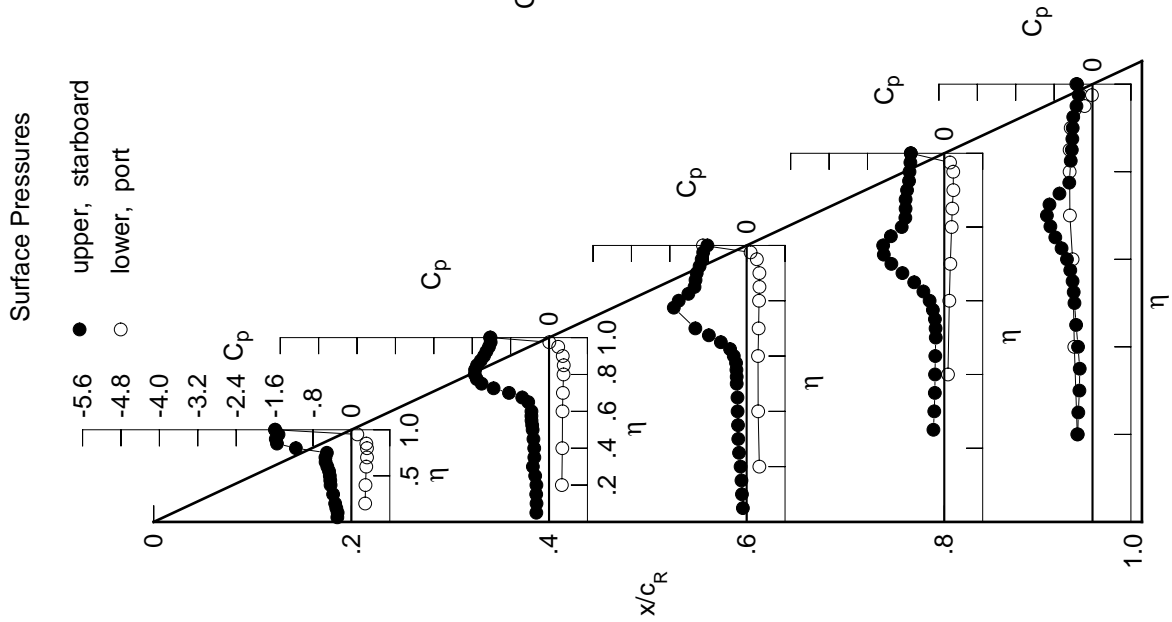

Table D1. Continued.

η	x/c_R .2	x/c_R .4	x/c_R .6	x/c_R .8	x/c_R .95
	$C_{p,u}$	$C_{p,u}$	$C_{p,u}$	$C_{p,u}$	$C_{p,u}$
0.050	-0.3535	-0.3282	-0.1176	*****	*****
0.100	-0.3479	-0.3186	-0.1311	*****	*****
0.150	-0.3667	-0.3259	-0.1469	*****	*****
0.200	-0.4036	-0.3395	-0.1806	*****	-0.3095
0.250	*****	-0.3697	-0.1908	-0.2491	-0.2697
0.300	-0.4670	-0.3534	-0.2071	-0.2248	-0.2271
0.350	*****	-0.3499	-0.2148	-0.2147	-0.2609
0.400	-0.4692	-0.3543	-0.2250	-0.2105	-0.3172
0.450	-0.4810	-0.3557	-0.2343	-0.2139	-0.3666
0.500	-0.4978	-0.3556	-0.2731	-0.2483	-0.4259
0.525	*****	-0.3537	-0.3012	-0.2862	-0.4706
0.550	-0.5103	-0.3608	-0.3517	-0.3671	-0.5354
0.575	*****	-0.3768	-0.4351	-0.4914	-0.6341
0.600	-0.5205	-0.4247	-0.5947	-0.6556	-0.7581
0.625	*****	*****	-0.7830	-0.8756	-0.8976
0.650	-0.4676	-0.8564	-1.0702	-1.1132	-0.9818
0.675	*****	-1.2413	-1.3393	-1.3322	-0.9395
0.700	-0.5959	-1.6360	-1.5554	-1.4261	-0.7806
0.725	*****	-1.8938	*****	-1.3391	-0.5335
0.750	-1.6898	-2.0246	*****	-1.0936	-0.4727
0.775	*****	-2.0295	-1.1867	-0.8947	-0.4791
0.800	-1.9213	-1.8789	-1.1130	-0.8563	*****
0.825	*****	-1.6237	-1.1097	-0.8434	-0.4715
0.850	-1.8074	-1.4727	-1.1164	-0.8569	-0.4352
0.875	*****	-1.4270	-1.1186	-0.8528	-0.4178
0.900	-1.6731	-1.3986	-1.0654	-0.8051	-0.4091
0.925	*****	-1.3152	-1.0403	-0.7510	-0.3995
0.950	-1.5966	-1.2514	-1.0337	-0.7406	-0.3305
0.975	*****	-1.2234	-1.0195	-0.7232	-0.2934
1.000	-1.6341	-1.2033	-0.9236	-0.7211	-0.3107
	$C_{p,l}$	$C_{p,l}$	$C_{p,l}$	$C_{p,l}$	$C_{p,l}$
-0.200	0.3408	0.3071	0.3006	*****	-0.3475
-0.400	0.3472	0.3230	0.2706	0.1017	-0.4128
-0.600	0.3592	0.3208	0.2726	0.1270	-0.4711
-0.700	0.3693	0.3290	0.2798	0.1457	-0.5194
-0.800	0.3576	0.3345	0.2891	0.1771	-0.4927
-0.850	0.3288	0.3301	0.2935	0.1896	-0.4749
-0.900	*****	0.2910	0.2791	0.2083	-0.4378
-0.950	0.0798	0.1652	0.1926	0.1838	-0.1442
-0.975	*****	-0.0613	0.0245	0.0899	-0.0105
-1.000	-1.6387	-1.2301	-0.9959	-0.7321	-0.3312

Medium Radius L.E.
 Run No. = 4, Point No. = 76
 $C_N = 0.721$, $C_m = -0.1013$
 $\alpha = 16.5^\circ$, $M_\infty = 0.599$
 $R_{mac} = 6.0 \times 10^6$

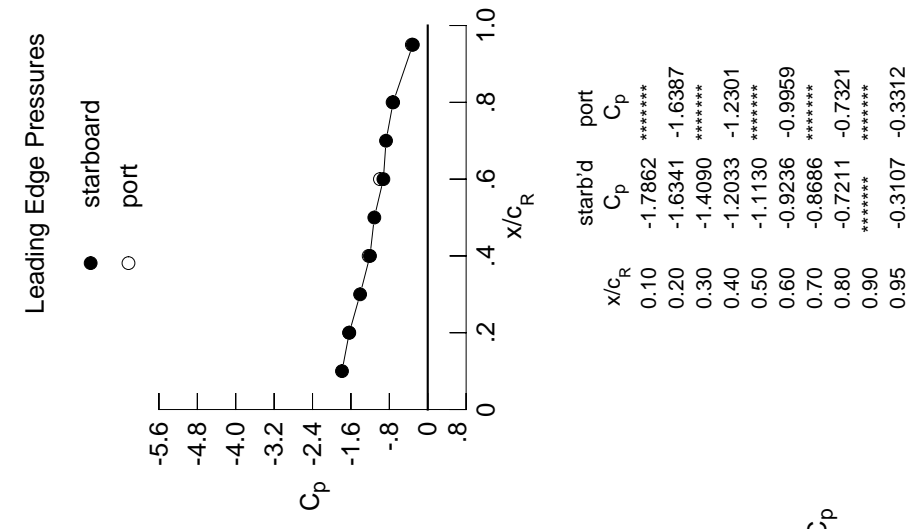
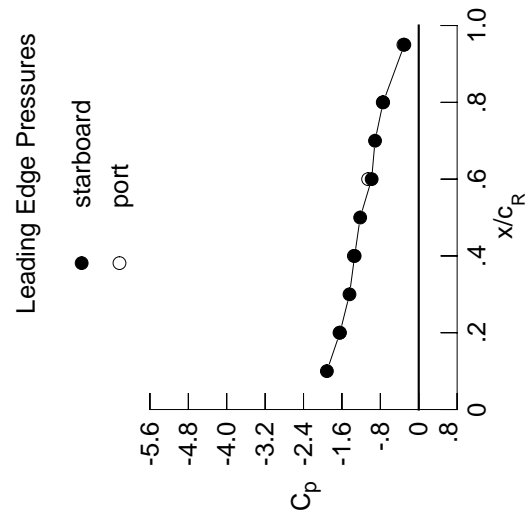

Table D1. Continued.

η	x/c_R .2	x/c_R .4	x/c_R .6	x/c_R .8	x/c_R .95
	$C_{p,u}$	$C_{p,u}$	$C_{p,u}$	$C_{p,u}$	$C_{p,u}$
0.050	-0.4255	-0.3910	-0.1544	*****	*****
0.100	-0.4244	-0.3866	-0.1702	*****	*****
0.150	-0.4442	-0.4021	-0.1883	*****	*****
0.200	-0.5256	-0.4195	-0.2201	*****	-0.3159
0.250	*****	-0.4125	-0.2268	-0.2725	-0.3075
0.300	-0.4925	-0.4147	-0.2485	-0.2515	-0.2759
0.350	*****	-0.4160	-0.2625	-0.2443	-0.2936
0.400	-0.5096	-0.4229	-0.2796	-0.2545	-0.3445
0.450	-0.5341	-0.4324	-0.3106	-0.2888	-0.4054
0.500	-0.5463	-0.4521	-0.4194	-0.3823	-0.5029
0.525	*****	-0.4842	-0.5015	-0.4705	-0.5768
0.550	-0.5298	-0.5468	-0.6372	-0.6040	-0.6650
0.575	*****	-0.6606	-0.7972	-0.7823	-0.7845
0.600	-0.4897	-0.8444	-1.0557	-0.9888	-0.8841
0.625	*****	*****	-1.2926	-1.2224	-0.9376
0.650	-0.7977	-1.4891	-1.5797	-1.4278	-0.8928
0.675	*****	-1.8374	-1.7716	-1.5276	-0.7287
0.700	-1.8998	-2.1325	-1.7718	-1.4261	-0.5282
0.725	*****	-2.2762	*****	-1.1696	-0.4767
0.750	-2.2666	-2.0518	*****	-0.9404	-0.4897
0.775	*****	-1.6957	-1.1839	-0.8839	-0.4834
0.800	-2.1862	-1.5638	-1.1715	-0.8757	*****
0.825	*****	-1.5278	-1.1637	-0.8690	-0.4458
0.850	-1.9631	-1.5376	-1.1749	-0.8832	-0.4047
0.875	*****	-1.5238	-1.1701	-0.8843	-0.3903
0.900	-1.7495	-1.4586	-1.1224	-0.8255	-0.3741
0.925	*****	-1.4040	-1.0921	-0.7735	-0.3713
0.950	-1.6598	-1.3815	-1.0853	-0.7620	-0.3179
0.975	*****	-1.3610	-1.0781	-0.7486	-0.2899
1.000	-1.6418	-1.3350	-0.9808	-0.7416	-0.2997
	$C_{p,l}$	$C_{p,l}$	$C_{p,l}$	$C_{p,l}$	$C_{p,l}$
-0.200	0.3956	0.3474	0.3354	*****	-0.3428
-0.400	0.3989	0.3648	0.3075	0.1272	-0.4313
-0.600	0.4080	0.3635	0.3065	0.1564	-0.5158
-0.700	0.4103	0.3683	0.3156	0.1724	-0.5480
-0.800	0.3820	0.3652	0.3200	0.2009	-0.4962
-0.850	0.3412	0.3486	0.3171	0.2132	-0.4696
-0.900	*****	0.2921	0.2881	0.2251	-0.4211
-0.950	0.0319	0.1250	0.1698	0.1782	-0.1263
-0.975	*****	-0.1458	-0.0350	0.0578	-0.0119
-1.000	-1.6501	-1.3510	-1.0543	-0.7496	-0.3191

Medium Radius L.E.
 Run No. = 4, Point No. = 77
 $C_N = 0.830$, $C_M = -0.1149$
 $\alpha = 18.5^\circ$, $M_\infty = 0.599$
 $R_{mac} = 6.0 \times 10^6$



x/c_R	starb'd C_p	port C_p
0.10	-1.9137	*****
0.20	-1.6418	-1.6501
0.30	-1.4421	*****
0.40	-1.3350	-1.3510
0.50	-1.2199	*****
0.60	-0.9808	-1.0543
0.70	-0.9106	*****
0.80	-0.7416	-0.7496
0.90	*****	*****
0.95	-0.2997	-0.3191

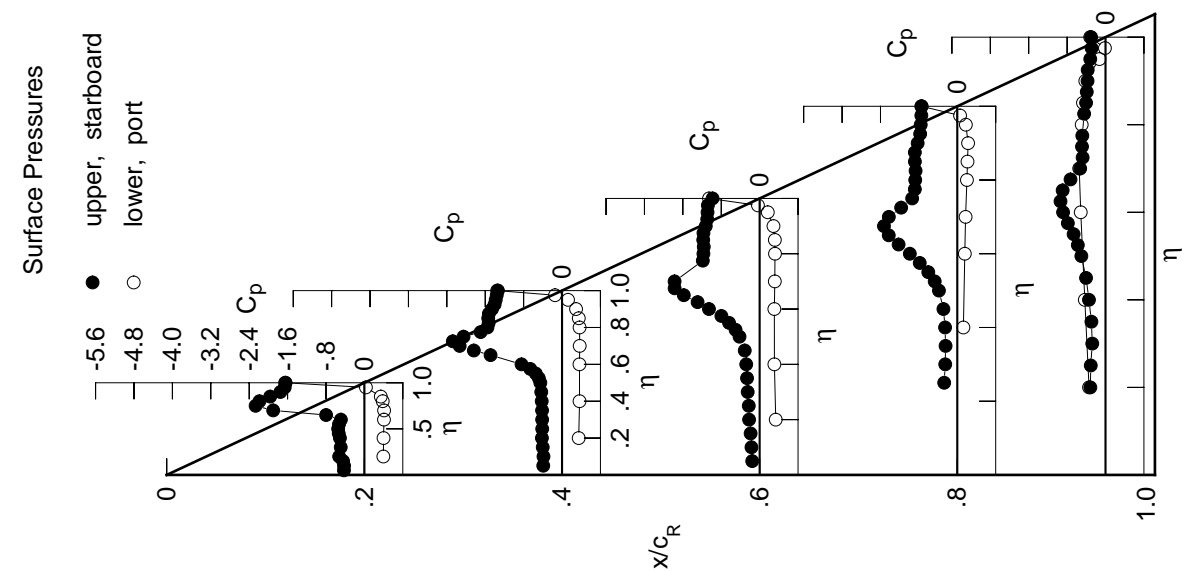
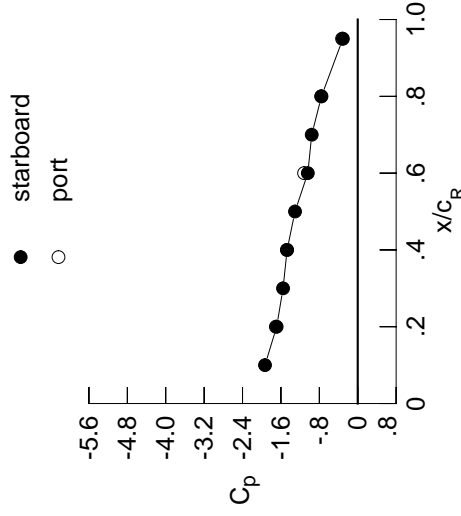

Table D1. Continued.

η	x/c_R	x/c_R	x/c_R	x/c_R	x/c_R	x/c_R	x/c_R
	$C_{p,u}$	$C_{p,u}$	$C_{p,u}$	$C_{p,u}$	$C_{p,u}$	$C_{p,l}$	$C_{p,l}$
0.050	-0.5086	-0.4656	-0.1929	*****	*****	*****	*****
0.100	-0.5069	-0.4603	-0.2085	*****	*****	*****	*****
0.150	-0.5698	-0.4886	-0.2241	*****	*****	*****	*****
0.200	-0.5724	-0.4853	-0.2634	*****	*****	-0.3142	*****
0.250	*****	-0.4885	-0.2702	-0.2979	-0.3308	*****	*****
0.300	-0.5626	-0.4955	-0.2978	-0.2913	-0.3487	*****	*****
0.350	*****	-0.5012	-0.3222	-0.2969	-0.3547	*****	*****
0.400	-0.5916	-0.5189	-0.3592	-0.3258	-0.3972	*****	*****
0.450	-0.5974	-0.5596	-0.4405	-0.4023	-0.4698	*****	*****
0.500	-0.5862	-0.6541	-0.6318	-0.5615	-0.5912	*****	*****
0.525	*****	-0.7537	-0.7759	-0.6863	-0.6782	*****	*****
0.550	-0.5856	-0.9007	-0.9635	-0.8569	-0.7625	*****	*****
0.575	*****	-1.1035	-1.1746	-1.0623	-0.8500	*****	*****
0.600	-0.8661	-1.3554	-1.4553	-1.2743	-0.8853	*****	*****
0.625	*****	*****	-1.6969	-1.4870	-0.8544	*****	*****
0.650	-1.8346	-1.9883	-1.9503	-1.6084	-0.7412	*****	*****
0.675	*****	-2.2598	-2.0244	-1.5187	-0.5599	*****	*****
0.700	-2.4509	-2.2450	-1.7429	-1.2728	-0.4677	*****	*****
0.725	*****	-1.8336	*****	-1.0024	-0.4839	*****	*****
0.750	-2.4968	-1.6661	*****	-0.9081	-0.4898	*****	*****
0.775	*****	-1.6238	-1.2665	-0.8891	-0.4694	*****	*****
0.800	-2.3257	-1.6305	-1.2607	-0.8828	*****	*****	*****
0.825	*****	-1.6485	-1.2569	-0.8750	-0.4223	*****	*****
0.850	-2.0078	-1.6525	-1.2696	-0.8969	-0.3875	*****	*****
0.875	*****	-1.5987	-1.2594	-0.8946	-0.3770	*****	*****
0.900	-1.8457	-1.5528	-1.1957	-0.8419	-0.3655	*****	*****
0.925	*****	-1.5260	-1.1498	-0.7868	-0.3599	*****	*****
0.950	-1.7583	-1.5140	-1.1446	-0.7800	-0.3244	*****	*****
0.975	*****	-1.4996	-1.1372	-0.7647	-0.3012	*****	*****
1.000	-1.6892	-1.4715	-1.0397	-0.7553	-0.3097	*****	*****
-0.200	0.4412	0.3939	0.3684	*****	-0.3532	*****	*****
-0.400	0.4492	0.4054	0.3436	0.1550	-0.4362	*****	*****
-0.600	0.4529	0.4028	0.3414	0.1835	-0.5403	*****	*****
-0.700	0.4472	0.4041	0.3491	0.2000	-0.5571	*****	*****
-0.800	0.4030	0.3921	0.3481	0.2240	-0.4934	*****	*****
-0.850	0.3469	0.3645	0.3387	0.2339	-0.4590	*****	*****
-0.900	*****	0.2868	0.2975	0.2386	-0.4022	*****	*****
-0.950	-0.0221	0.0799	0.1432	0.1678	-0.1129	*****	*****
-0.975	*****	-0.2365	-0.0983	0.0220	-0.0194	*****	*****
-1.000	-1.7053	-1.4758	-1.1173	-0.7614	-0.3267	*****	*****

Medium Radius L.E.
 Run No. = 4, Point No. = 78
 $C_N = 0.937$, $C_m = -0.1268$
 $\alpha = 20.5^\circ$, $M_\infty = 0.599$
 $R_{mac} = 6.0 \times 10^6$

Leading Edge Pressures



x/c_R	starb'd C_p	port C_p
0.10	-1.9322	*****
0.20	-1.6892	-1.7053
0.30	-1.5556	*****
0.40	-1.4715	-1.4758
0.50	-1.3066	*****
0.60	-1.0397	-1.1173
0.70	-0.9584	*****
0.80	-0.7553	-0.7614
0.90	*****	*****
0.95	-0.3097	-0.3267

Surface Pressures

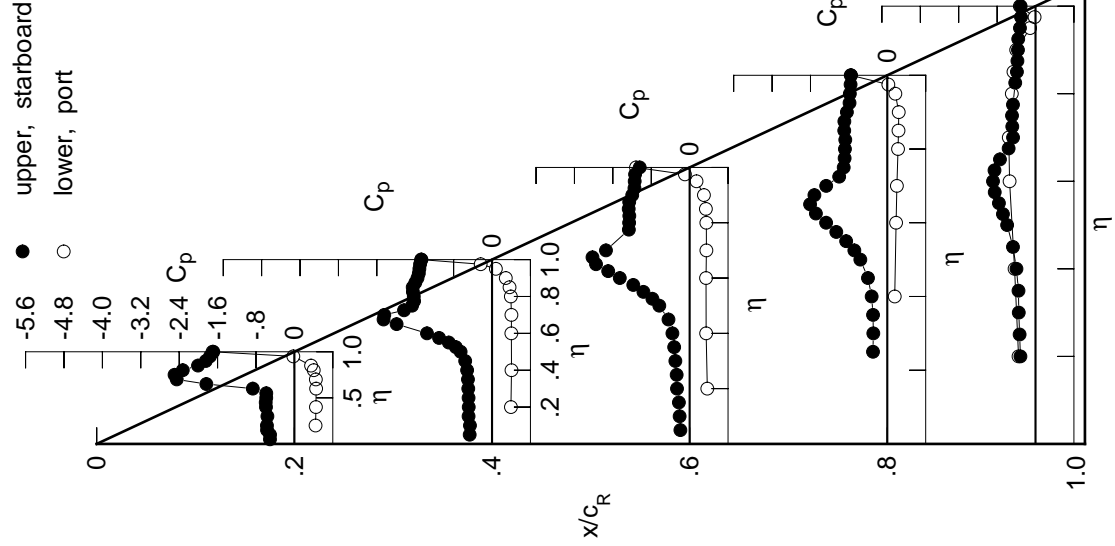
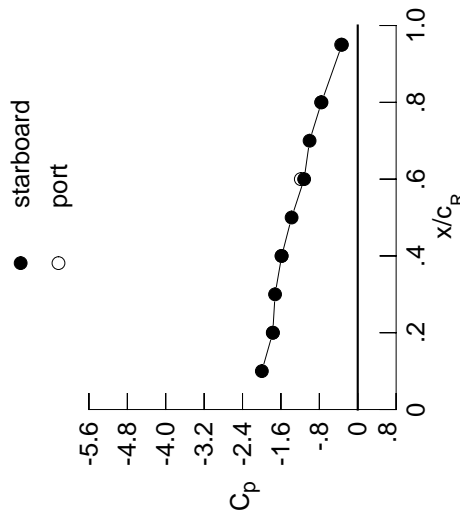

Table D1. Continued.

η	x/c_R	$C_{p,u}$	x/c_R	$C_{p,u}$	x/c_R	$C_{p,u}$	x/c_R	$C_{p,u}$	x/c_R	$C_{p,u}$
0.050	0.2	-0.5968	0.4	-0.5403	0.6	-0.2303	0.8	0.4045	0.95	0.3840
0.100		-0.6019		-0.5338		-0.2465		0.3763		-0.4689
0.150		-0.6654		-0.5618		-0.2647		0.3742		0.2105
0.200		-0.6516		-0.5669		-0.2888		0.3830		0.2245
0.250		0.3044		-0.5689		-0.3279		0.3751		0.2506
0.300		-0.6460		-0.5829		-0.3550		0.3568		0.2552
0.350		0.3652		-0.6052		-0.3969		0.2997		0.2503
0.400		-0.6052		-0.6052		-0.4252		0.1101		0.1572
0.450		-0.6768		-0.6571		-0.4701		-0.1652		-0.0281
0.500		-0.6813		-0.7592		-0.6027		-0.7631		-0.3453
0.550		-0.7006		-0.9698		-0.8660		-1.1859		-1.5889
0.525		0.6675		-1.1384		-1.0458		-1.3776		-1.5889
0.550		0.7488		-1.3493		-1.2580		-1.1164		-1.1859
0.575		0.8087		-1.5832		-1.4812		-0.7545		-0.7631
0.600		0.8269		-1.5292		-1.8343		-0.3294		-0.3294
0.625		0.7484		0.3044		-1.9874		-0.8912		-0.8912
0.650		0.6131		-2.4206		-2.3567		-0.8763		-0.4454
0.675		0.4796		0.3652		-2.2950		-1.3466		-0.8681
0.700		0.4662		-2.8554		-1.9382		-1.3449		-0.8613
0.725		0.4747		0.3696		-1.7896		-1.2177		-0.7891
0.750		0.4657		-2.7479		-1.7584		-1.2702		-0.8367
0.775		0.4454		-2.3261		-1.7601		-1.2130		-0.7784
0.800		0.4151		0.3807		-1.7731		-1.3424		-0.8760
0.825		0.3898		-2.0328		-1.7565		-1.3596		-0.8799
0.850		0.3696		0.3696		-1.6956		-1.3424		-0.8760
0.875		0.3558		-1.9356		-1.6558		-1.2702		-0.8367
0.900		0.3336		0.3336		-1.6341		-1.2177		-0.7891
0.925		0.3176		-1.8340		-1.6163		-1.2130		-0.7784
0.950		0.3176		0.3176		-1.6096		-1.2111		-0.7627
0.975		0.3294		-1.7702		-1.5841		-1.1164		-0.7545
1.000		0.3294		0.3294		0.3294		0.3294		0.3294
-0.200		0.3840		0.4922		0.4367		0.4045		0.3840
-0.400		0.4689		0.4963		0.4460		0.3763		0.1829
-0.600		0.5574		0.4915		0.4392		0.3742		0.2105
-0.700		0.5596		0.4774		0.4391		0.3830		0.2245
-0.800		0.4818		0.4155		0.4167		0.3751		0.2506
-0.850		0.4454		0.3469		0.3740		0.3568		0.2552
-0.900		0.3815		0.2758		0.2758		0.2997		0.2503
-0.950		0.1013		0.0813		0.0290		0.1101		0.1572
-0.975		0.0281		0.0281		-0.3294		-0.1652		-0.0128
-1.000		0.3453		-1.7667		-1.5889		-1.1859		-0.7631

Medium Radius L.E.
 Run No. = 4, Point No. = 79
 $C_N = 1.042$, $C_M = -0.1382$
 $\alpha = 22.5^\circ$, $M_\infty = 0.599$
 $R_{mac} = 6.0 \times 10^6$

Leading Edge Pressures



x/c_R	starb'd C_p	port C_p
0.10	-1.9978	0.3044
0.20	-1.7702	-1.7667
0.30	-1.7222	0.3044
0.40	-1.5841	-1.5889
0.50	-1.3776	0.3044
0.60	-1.1164	-1.1859
0.70	-1.0035	0.3044
0.80	-0.7545	-0.7631
0.90	0.3294	0.3294
0.95	-0.3294	-0.3453

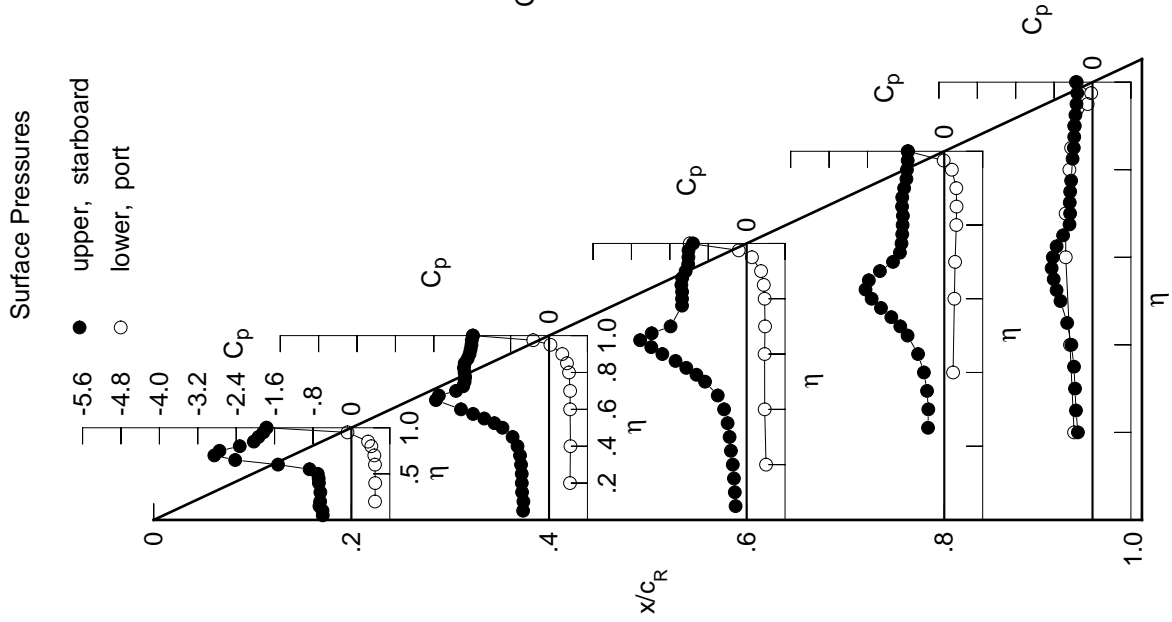

Table D1. Continued.

η	x/c_R	$C_{p,u}$	x/c_R	$C_{p,u}$	x/c_R	$C_{p,u}$	x/c_R	$C_{p,u}$	x/c_R	$C_{p,u}$
0.050		-0.6897	0.2	-0.6167	0.4	-0.2663	0.6	-0.2663	0.8	0.95
0.100		-0.6955		-0.6146		-0.2884		-0.2884		
0.150		-0.7545		-0.6194		-0.3077		-0.3077		
0.200		-0.7549		-0.6291		-0.3356		-0.3356		
0.250		*****		-0.6728		-0.3687		-0.3687		-0.2855
0.300		-0.7561		-0.6883		-0.4208		-0.3992		-0.3760
0.350		*****		-0.7305		-0.4892		-0.4439		-0.4097
0.400		-0.7864		-0.8336		-0.5978		-0.5380		-0.4348
0.450		-0.8294		-1.0199		-0.7910		-0.7110		-0.5058
0.500		-1.0092		-1.3236		-1.1088		-0.9742		-0.6029
0.525		*****		-1.5336		-1.3044		-1.1415		-0.7241
0.550		-1.4878		-1.7590		-1.5301		-1.3437		-0.7824
0.575		*****		-1.9919		-1.7454		-1.5448		-0.7980
0.600		-2.2267		-2.2090		-2.0012		-1.6696		-0.7913
0.625		*****		*****		-2.2154		-1.5433		-0.7237
0.650		-2.8181		-2.5013		-2.3272		-1.2961		-0.6213
0.675		*****		-2.1467		-1.7236		-1.0332		-0.5082
0.700		-2.9382		-1.9669		-1.5128		-0.9002		-0.4655
0.725		*****		-1.8976		*****		-0.8644		-0.4963
0.750		-2.6099		-1.8892		*****		-0.8464		-0.4927
0.775		*****		-1.8708		-1.4250		-0.8368		-0.4890
0.800		-2.2750		-1.8822		-1.4295		-0.8328		-0.4717
0.825		*****		-1.8908		-1.4383		-0.8281		*****
0.850		-2.1509		-1.8742		-1.4704		-0.8383		-0.4563
0.875		*****		-1.8106		-1.4409		-0.8488		-0.4410
0.900		-2.0209		-1.7596		-1.3539		-0.8227		-0.4317
0.925		*****		-1.7309		-1.2956		-0.7913		-0.4210
0.950		-1.9358		-1.7185		-1.2911		-0.7830		-0.4068
0.975		*****		-1.7150		-1.2899		-0.7654		-0.3880
1.000		-1.8835		-1.6959		-1.1821		-0.7590		-0.3788
-0.200		$C_{p,l}$	$C_{p,l}$	$C_{p,l}$	$C_{p,l}$	$C_{p,l}$	$C_{p,l}$	$C_{p,l}$	$C_{p,l}$	$C_{p,l}$
-0.400		0.5454	0.4815	0.4387	0.3932	0.3532	0.3182	0.2832	0.2482	0.2132
-0.600		0.5463	0.4921	0.4144	0.2086	0.2429	0.2772	0.3115	0.3458	0.3801
-0.700		0.5327	0.4797	0.4065	0.2429	0.2514	0.2600	0.2685	0.2770	0.2855
-0.800		0.5087	0.4738	0.4168	0.2514	0.2752	0.3095	0.3438	0.3781	0.4124
-0.850		0.4277	0.4380	0.3989	0.2752	0.2760	0.2760	0.2760	0.2760	0.2760
-0.875		0.3448	0.3877	0.3726	0.2760	0.2760	0.2760	0.2760	0.2760	0.2760
-0.900		*****	0.2640	0.2989	0.2607	0.2607	0.2607	0.2607	0.2607	0.2607
-0.950		-0.1460	-0.0201	0.0732	0.1454	0.1454	0.1454	0.1454	0.1454	0.1454
-0.975		*****	-0.4162	-0.2373	-0.0479	-0.0512	-0.0512	-0.0512	-0.0512	-0.0512
-1.000		-1.9194	-1.6763	-1.2770	-0.7566	-0.4195	-0.0820	0.2482	0.5015	0.7548

Medium Radius L.E.
 Run No. = 4, Point No. = 80
 $C_N = 1.146$, $C_m = -0.1521$
 $\alpha = 24.6^\circ$, $M_\infty = 0.599$
 $R_{mac} = 6.0 \times 10^6$

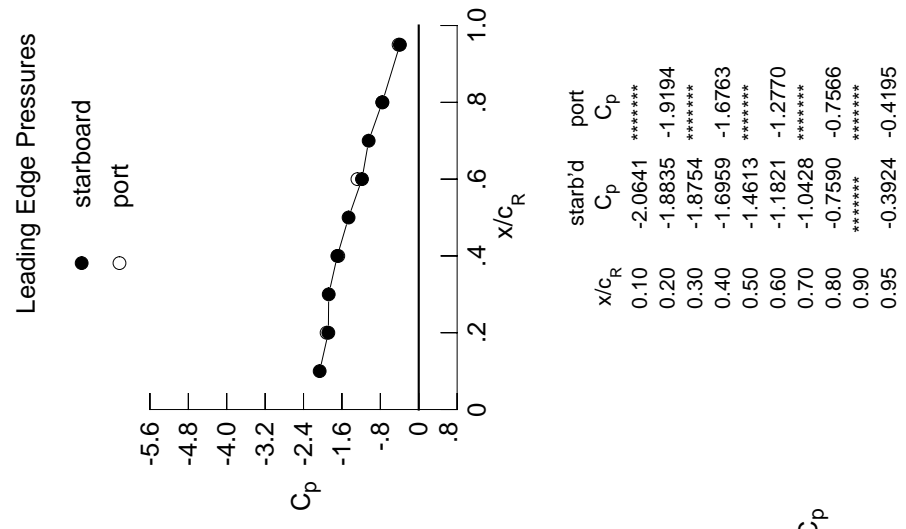
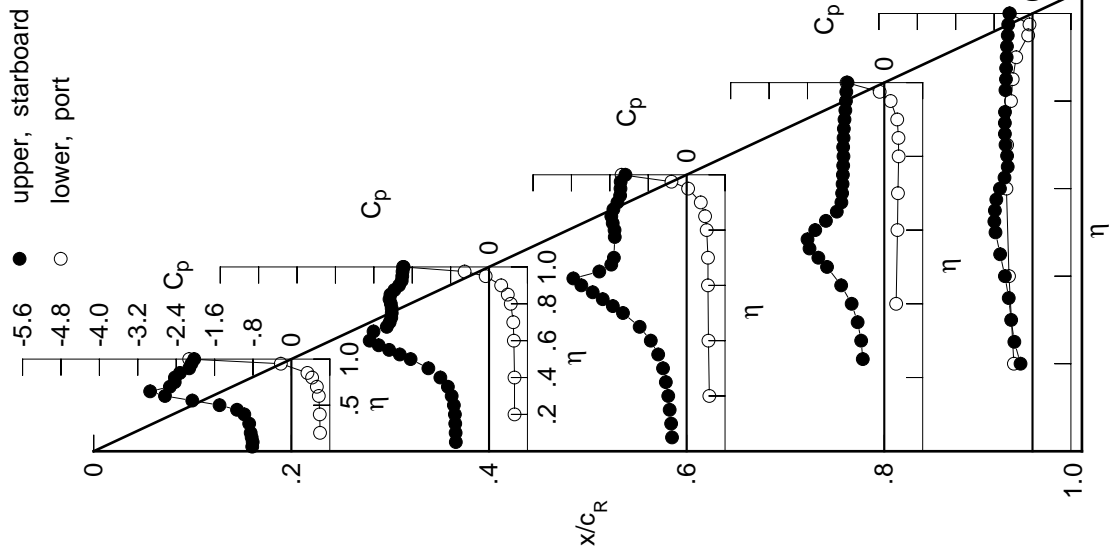

Table D1. Concluded.

η	x/c_R .2	x/c_R .4	x/c_R .6	x/c_R .8	x/c_R .95
	$C_{p,u}$	$C_{p,u}$	$C_{p,u}$	$C_{p,u}$	$C_{p,u}$
0.050	-0.8159	-0.6919	-0.3052	*****	*****
0.100	-0.8066	-0.6959	-0.3231	*****	*****
0.150	-0.8272	-0.7040	-0.3537	*****	*****
0.200	-0.8479	-0.7114	-0.3834	*****	-0.2497
0.250	*****	-0.7331	-0.4334	-0.4480	-0.3783
0.300	-0.8792	-0.7782	-0.4924	-0.4815	-0.4450
0.350	*****	-0.8573	-0.5931	-0.5555	-0.4953
0.400	-0.9811	-1.0143	-0.7470	-0.6797	-0.5750
0.450	-1.1326	-1.2642	-0.9794	-0.8984	-0.6743
0.500	-1.4968	-1.6341	-1.3261	-1.1927	-0.7709
0.525	*****	-1.8589	-1.5374	-1.3740	-0.7950
0.550	-2.0645	-2.0813	-1.7482	-1.5572	-0.7844
0.575	*****	-2.2996	-1.9569	-1.5996	-0.7541
0.600	-2.6338	-2.4861	-2.1932	-1.4386	-0.6788
0.625	*****	*****	-2.3605	-1.2163	-0.5833
0.650	-2.9420	-2.4066	-1.8199	-0.9895	-0.5168
0.675	*****	-2.1305	-1.5701	-0.8935	-0.5295
0.700	-2.5320	-2.0701	-1.5158	-0.8786	-0.5622
0.725	*****	-2.0369	*****	-0.8692	-0.5756
0.750	-2.4301	-2.0271	*****	-0.8623	-0.5760
0.775	*****	-2.0284	-1.4976	-0.8559	-0.5739
0.800	-2.4264	-2.0452	-1.5013	-0.8502	*****
0.825	*****	-2.0739	-1.5400	-0.8564	-0.5638
0.850	-2.3220	-2.0547	-1.5698	-0.8478	-0.5528
0.875	*****	-1.9714	-1.5265	-0.8423	-0.5495
0.900	-2.1285	-1.8748	-1.4423	-0.8287	-0.5383
0.925	*****	-1.8192	-1.3855	-0.8114	-0.5322
0.950	-2.0825	-1.8081	-1.3785	-0.7984	-0.5157
0.975	*****	-1.8017	-1.3743	-0.7913	-0.5060
1.000	-2.0247	-1.7792	-1.2755	-0.7654	-0.4825
	$C_{p,l}$	$C_{p,l}$	$C_{p,l}$	$C_{p,l}$	$C_{p,l}$
-0.200	0.5969	0.5311	0.4729	*****	-0.3883
-0.400	0.5915	0.5306	0.4544	0.2470	-0.4895
-0.600	0.5709	0.5172	0.4442	0.2747	-0.5432
-0.700	0.5308	0.5048	0.4449	0.2845	-0.5297
-0.800	0.4311	0.4532	0.4176	0.2988	-0.4484
-0.850	0.3348	0.3902	0.3842	0.2953	-0.4131
-0.900	*****	0.2529	0.2948	0.2698	-0.3389
-0.950	-0.2199	-0.0706	0.0306	0.1322	-0.0902
-0.975	*****	-0.5091	-0.3167	-0.0957	-0.0629
-1.000	-2.1297	-1.7916	-1.3556	-0.7857	-0.4716

Surface Pressures



Medium Radius L.E.
 Run No. = 4, Point No. = 81
 $C_N = 1.263$, $C_m = -0.1716$
 $\alpha = 26.6^\circ$, $M_\infty = 0.599$
 $R_{mac} = 6.0 \times 10^6$

Leading Edge Pressures

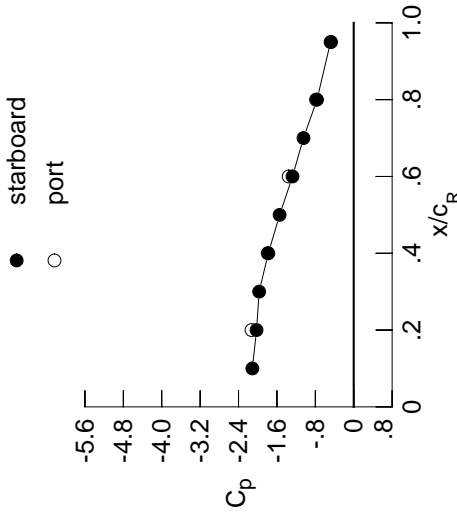

x/c_R	starbd C_p	port C_p
0.10	-2.1117	*****
0.20	-2.0247	-2.1297
0.30	-1.9707	*****
0.40	-1.7792	-1.7916
0.50	-1.5436	*****
0.60	-1.2755	-1.3556
0.70	-1.0468	*****
0.80	-0.7654	-0.7857
0.90	*****	*****
0.95	-0.4825	-0.4716

Table D2. Tabulations and Plots of Surface Pressure Coefficients.

η	$x/c_R = .2$		$x/c_R = .4$		$x/c_R = .6$		$x/c_R = .8$		$x/c_R = .95$	
	$C_{p,u}$	$C_{p,u}$	$C_{p,u}$	$C_{p,u}$	$C_{p,u}$	$C_{p,u}$	$C_{p,u}$	$C_{p,u}$	$C_{p,u}$	$C_{p,u}$
0.050	-0.0042	0.0097	0.1115	0.0750	0.0631	-0.0898	-0.3092	0.0005	0.0097	0.1018
0.100	-0.0005	0.0097	0.1018	0.0906	0.0631	-0.0898	-0.3092	-0.0044	0.0108	0.0906
0.150	-0.0058	0.0134	0.0750	0.0631	-0.0898	-0.3092	0.0058	0.0134	0.0750	
0.200	0.0093	0.0631	-0.0898	-0.3092	0.0093	0.0631	-0.3092	0.0093	0.0631	
0.250	0.0119	0.0084	0.0520	-0.0811	-0.3330	0.0119	0.0084	0.0520		
0.300	0.0070	0.0431	-0.0748	-0.3417	0.0070	0.0431	-0.3417			
0.350	-0.0277	0.0049	0.0388	-0.0631	-0.3569	-0.0277	0.0049	0.0388		
0.400	-0.0331	0.0013	0.0462	-0.0630	-0.3625	-0.0331	0.0013	0.0462		
0.450	-0.0380	0.0032	0.0214	-0.0580	-0.3660	-0.0380	0.0032	0.0214		
0.500	0.0012	0.0206	-0.0598	-0.3676	0.0012	0.0206	-0.3676			
0.525	-0.0408	-0.0066	0.0179	-0.0560	-0.3678	-0.0408	-0.0066	0.0179		
0.550	-0.0073	0.0242	-0.0570	-0.3701	-0.0073	0.0242	-0.3701			
0.575	-0.0454	-0.0102	0.0105	-0.0584	-0.3702	-0.0454	-0.0102	0.0105		
0.600	0.0124	0.0554	-0.0699	0.0124	0.0554	-0.0699				
0.625	-0.0449	-0.0131	0.0080	-0.0558	-0.3677	-0.0449	-0.0131	0.0080		
0.650	0.0244	-0.0001	-0.0569	-0.3587	0.0244	-0.0001	-0.3587			
0.675	-0.0399	-0.0314	-0.0008	-0.0585	-0.3605	-0.0399	-0.0314	-0.0008		
0.700	0.0384	0.0585	-0.0585	0.0384	0.0585	-0.0585				
0.725	-0.0324	-0.0450	0.0529	-0.0324	-0.0450	0.0529				
0.750	-0.0487	-0.0221	-0.0657	-0.3465	-0.0487	-0.0221	-0.3465			
0.775	-0.0124	-0.0510	-0.0324	-0.0694	-0.0124	-0.0510	-0.0694			
0.800	0.0483	-0.0420	-0.0673	-0.3716	0.0483	-0.0420	-0.3716			
0.825	-0.0066	-0.0458	-0.0514	-0.0891	-0.3674	-0.0066	-0.0458	-0.0514		
0.850	0.0366	-0.0566	-0.0971	-0.4553	0.0366	-0.0566	-0.4553			
0.875	0.0393	-0.0246	-0.0533	-0.1073	-0.5489	0.0393	-0.0246	-0.0533		
0.900	0.0031	-0.0401	-0.1032	-0.9720	0.0031	-0.0401	-0.9720			
0.925	0.0898	0.0319	-0.0095	-0.0738	-0.4934	0.0898	0.0319	-0.0095		
0.950	0.0875	0.0447	-0.0153	-0.2449	0.0875	0.0447	-0.2449			
0.975	0.2131	0.2006	0.1948	0.1548	0.0896	0.2131	0.2006	0.1948		
1.000	0.2131	0.2006	0.1948	0.1548	0.0896					
-0.200	-0.0257	-0.0040	0.0555	0.0555	-0.3319	-0.0257	-0.0040	0.0555		
-0.400	-0.0505	-0.0025	0.0189	-0.0805	-0.3542	-0.0505	-0.0025	0.0189		
-0.600	-0.0736	-0.0268	-0.0077	-0.0706	-0.3674	-0.0736	-0.0268	-0.0077		
-0.700	-0.0746	-0.0637	-0.0284	-0.0758	-0.3763	-0.0746	-0.0637	-0.0284		
-0.800	-0.0608	0.0699	-0.0699	-0.0880	-0.3831	-0.0608	0.0699	-0.0699		
-0.850	0.0882	-0.0991	-0.1189	-0.4478	0.0882	-0.0991	-0.1189	-0.4478		
-0.900	0.0744	-0.1119	-0.1532	-0.5824	0.0744	-0.1119	-0.1532	-0.5824		
-0.950	0.0364	-0.0349	-0.0799	-0.1442	-0.5127	0.0364	-0.0349	-0.0799		
-0.975	0.0219	-0.0333	-0.0924	-0.3164	0.0219	-0.0333	-0.0924	-0.3164		
-1.000	0.1911	0.1821	0.1402	0.1433	0.0857	0.1911	0.1821	0.1402	0.1433	0.0857

Medium Radius L.E.
 Run No. = 23 , Point No. = 459
 $C_N = -0.020$, $C_m = 0.0021$
 $\alpha = -0.6^\circ$, $M_\infty = 0.599$
 $R_{mac} = 59.9 \times 10^6$

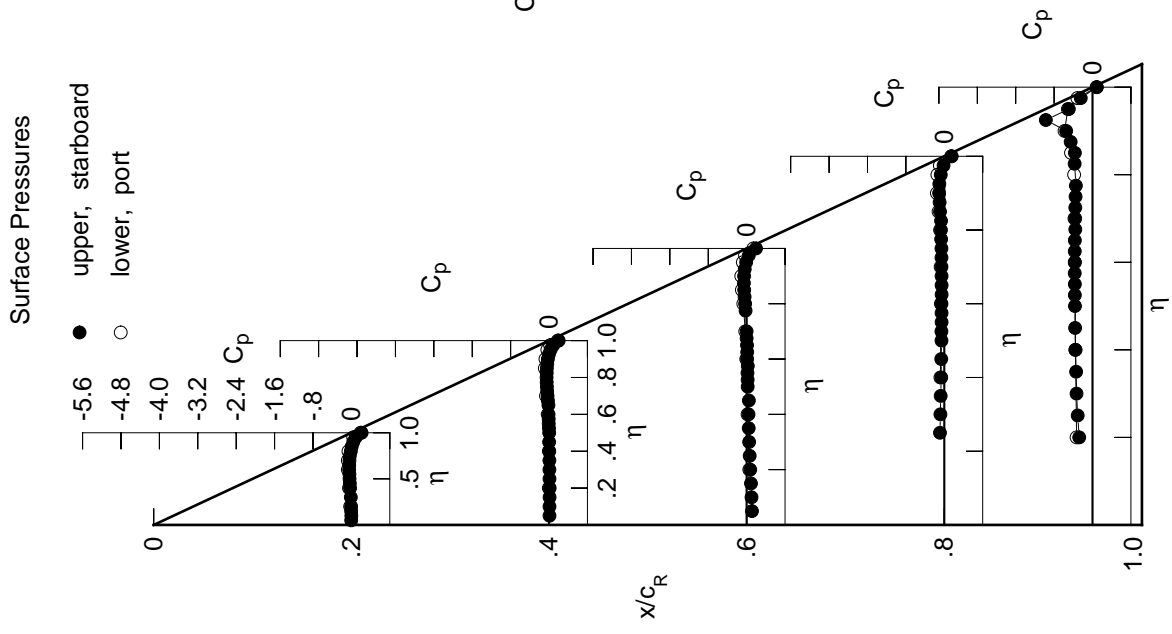

Leading Edge Pressures

● starboard
 ○ port

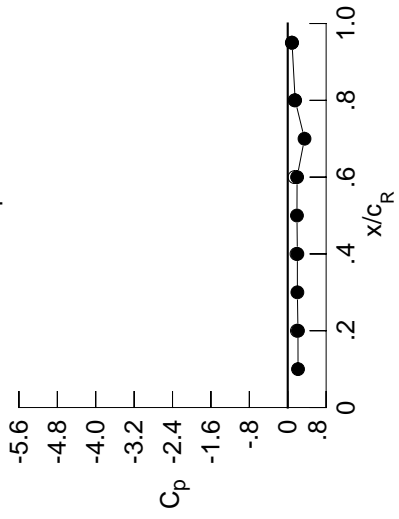

x/c_R	starb'd C_p	port C_p
0.10	0.2146	*****
0.20	0.2131	0.1911
0.30	0.2009	*****
0.40	0.2006	0.1821
0.50	0.1922	*****
0.60	0.1948	0.1402
0.70	0.3495	*****
0.80	0.1548	0.1433
0.90	*****	*****
0.95	0.0896	0.0857

Table D2. Continued.

η	$x/c_R = .2$		$x/c_R = .4$		$x/c_R = .6$		$x/c_R = .8$		$x/c_R = .95$	
	$C_{p,u}$	$C_{p,u}$	$C_{p,u}$	$C_{p,u}$	$C_{p,u}$	$C_{p,u}$	$C_{p,u}$	$C_{p,u}$	$C_{p,u}$	$C_{p,u}$
0.050	-0.0116	0.0041	0.1071	0.1071	0.0586	0.0586	0.0273	0.0273	0.0112	0.0112
0.100	-0.0072	0.0048	0.0987	0.0987	0.0493	0.0493	0.0212	0.0212	0.0074	0.0074
0.150	-0.0106	0.0048	0.0866	0.0866	0.0389	0.0389	0.0161	0.0161	0.0059	0.0059
0.200	-0.0124	0.0079	0.0723	0.0723	0.0341	0.0341	0.0112	0.0112	0.0042	0.0042
0.250	0.0000	0.0036	0.0586	0.0586	0.0273	0.0273	0.0074	0.0074	0.0024	0.0024
0.300	-0.0200	0.0027	0.0493	0.0493	0.0212	0.0212	0.0161	0.0161	0.0016	0.0016
0.350	0.0000	0.0002	0.0389	0.0389	0.0161	0.0161	0.0112	0.0112	0.0012	0.0012
0.400	-0.0349	-0.0004	0.0341	0.0341	0.0112	0.0112	0.0074	0.0074	0.0008	0.0008
0.450	-0.0411	-0.0051	0.0424	0.0424	0.0064	0.0064	0.0059	0.0059	0.0006	0.0006
0.500	-0.0467	-0.0037	0.0155	0.0155	0.00613	0.00613	0.0042	0.0042	0.0005	0.0005
0.525	0.0000	-0.0068	0.0161	0.0161	0.00640	0.00640	0.003655	0.003655	0.0004	0.0004
0.550	-0.0505	-0.0142	0.0112	0.0112	0.00590	0.00590	0.003667	0.003667	0.0003	0.0003
0.575	0.0000	-0.0155	0.0193	0.0193	0.00616	0.00616	0.003675	0.003675	0.0002	0.0002
0.600	-0.0553	-0.0177	0.0042	0.0042	0.00619	0.00619	0.003682	0.003682	0.0001	0.0001
0.625	0.0000	0.0000	0.0074	0.0074	0.00594	0.00594	0.003668	0.003668	0.0000	0.0000
0.650	-0.0555	-0.0216	0.0024	0.0024	0.00598	0.00598	0.003657	0.003657	0.0000	0.0000
0.675	0.0000	-0.0324	-0.0069	-0.0069	0.00618	0.00618	0.003563	0.003563	0.0000	0.0000
0.700	-0.0508	-0.0399	-0.0068	-0.0068	0.00624	0.00624	0.003567	0.003567	0.0000	0.0000
0.725	0.0000	-0.0485	0.0000	0.0000	0.00634	0.00634	0.003545	0.003545	0.0000	0.0000
0.750	-0.0449	-0.0557	0.0000	0.0000	0.00659	0.00659	0.003472	0.003472	0.0000	0.0000
0.775	0.0000	-0.0601	-0.0314	-0.0314	0.00716	0.00716	0.003403	0.003403	0.0000	0.0000
0.800	-0.0252	-0.0626	-0.0424	-0.0424	0.00776	0.00776	0.003333	0.003333	0.0000	0.0000
0.825	0.0000	-0.0627	-0.0534	-0.0534	0.00751	0.00751	0.003666	0.003666	0.0000	0.0000
0.850	-0.0070	-0.0601	-0.0634	-0.0634	0.00982	0.00982	0.003623	0.003623	0.0000	0.0000
0.875	0.0000	-0.0524	-0.0715	-0.0715	0.1083	0.1083	0.004531	0.004531	0.0000	0.0000
0.900	0.0246	-0.0429	-0.0704	-0.0704	0.1205	0.1205	0.005504	0.005504	0.0000	0.0000
0.925	0.0000	-0.0214	-0.0593	-0.0593	0.1185	0.1185	0.009875	0.009875	0.0000	0.0000
0.950	0.0740	0.0129	-0.0315	-0.0315	0.0931	0.0931	0.005058	0.005058	0.0000	0.0000
0.975	0.0000	0.0677	0.0236	0.0236	0.0376	0.0376	0.002619	0.002619	0.0000	0.0000
1.000	0.2128	0.2057	0.2076	0.2076	0.1630	0.1630	0.0976	0.0976	0.0954	0.0954
-0.200	-0.0181	0.0019	0.0588	0.0588	0.0333	0.0333	0.0112	0.0112	0.0074	0.0074
-0.400	-0.0433	0.0043	0.0237	0.0237	0.0766	0.0766	0.03567	0.03567	0.0212	0.0212
-0.600	-0.0629	-0.0188	-0.0015	-0.0015	0.0678	0.0678	0.03703	0.03703	0.0161	0.0161
-0.700	-0.0632	-0.0539	-0.0209	-0.0209	0.0705	0.0705	0.03786	0.03786	0.0112	0.0112
-0.800	-0.0464	0.0000	-0.0596	-0.0596	0.0820	0.0820	0.03885	0.03885	0.0074	0.0074
-0.850	0.0000	-0.0727	-0.0858	-0.0858	0.1089	0.1089	0.04510	0.04510	0.0059	0.0059
-0.900	0.0000	-0.0551	-0.0945	-0.0945	0.1390	0.1390	0.05813	0.05813	0.0042	0.0042
-0.950	0.0551	-0.0135	-0.0576	-0.0576	0.1240	0.1240	0.04990	0.04990	0.0036	0.0036
-0.975	0.0000	0.0456	-0.0071	-0.0071	0.0676	0.0676	0.02974	0.02974	0.0026	0.0026
-1.000	0.1966	0.1909	0.1519	0.1519	0.1582	0.1582	0.0954	0.0954	0.0954	0.0954

Medium Radius L.E.

Run No. = 23 , Point No. = 460

$C_N = -0.009$, $C_m = 0.0003$

$\alpha = -0.3^\circ$, $M_\infty = 0.599$

$R_{mac} = 59.9 \times 10^6$

Leading Edge Pressures

● starboard
○ port

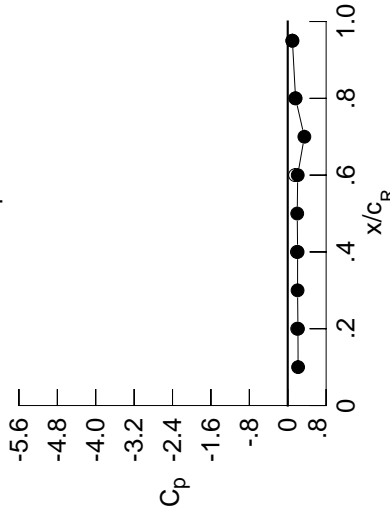

x/c_R	starb'd C_p	port C_p
0.10	0.2160	0.1966
0.20	0.2128	0.1966
0.30	0.2050	0.1909
0.40	0.2057	0.1909
0.50	0.1977	0.1909
0.60	0.2076	0.1519
0.70	0.3464	0.1582
0.80	0.1630	0.1582
0.90	0.0976	0.0954
0.95	0.0976	0.0954

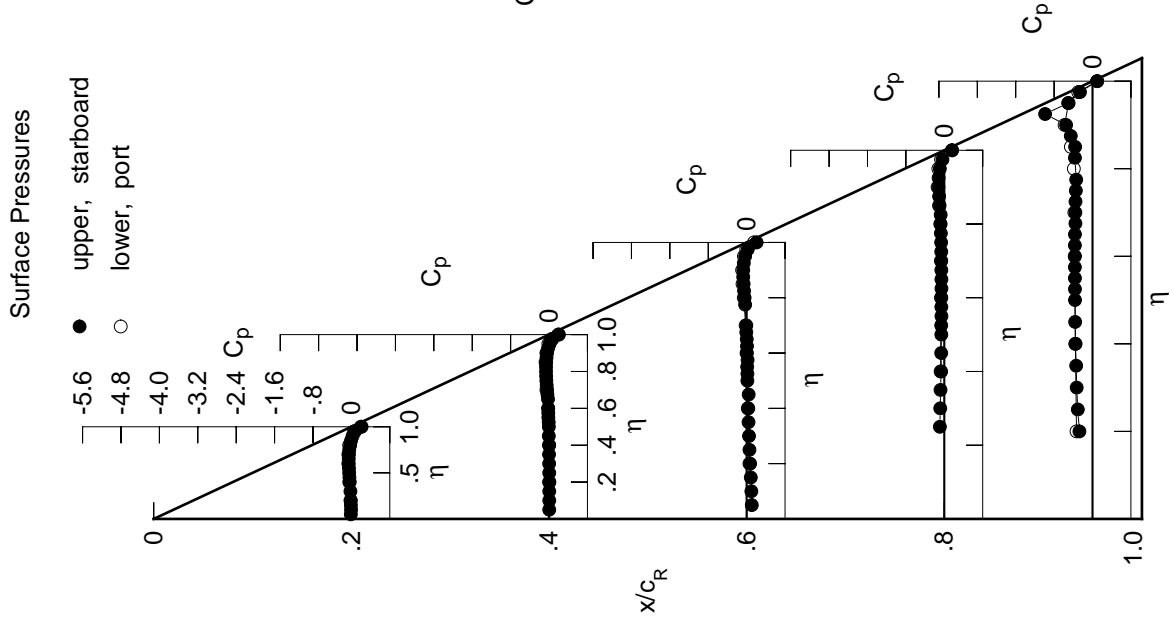

Table D2. Continued.

η	x/c_R .2	x/c_R .4	x/c_R .6	x/c_R .8	x/c_R .95
	$C_{p,u}$	$C_{p,u}$	$C_{p,u}$	$C_{p,u}$	$C_{p,u}$
0.050	-0.0290	-0.0109	0.0986	*****	*****
0.100	-0.0251	-0.0099	0.0886	*****	*****
0.150	-0.0287	-0.0100	0.0767	*****	*****
0.200	-0.0317	-0.0069	0.0616	*****	-0.2662
0.250	*****	-0.0115	0.0483	-0.0987	-0.2976
0.300	-0.0382	-0.0116	0.0380	-0.0909	-0.3230
0.350	*****	-0.0151	0.0273	-0.0843	-0.3318
0.400	-0.0568	-0.0167	0.0226	-0.0740	-0.3481
0.450	-0.0633	-0.0227	0.0294	-0.0733	-0.3538
0.500	-0.0701	-0.0217	0.0036	-0.0696	-0.3562
0.525	*****	-0.0259	0.0012	-0.0718	-0.3586
0.550	-0.0763	-0.0337	-0.0040	-0.0689	-0.3589
0.575	*****	-0.0349	0.0038	-0.0703	-0.3621
0.600	-0.0832	-0.0388	-0.0106	-0.0726	-0.3610
0.625	*****	*****	-0.0094	-0.0699	-0.3606
0.650	-0.0860	-0.0442	-0.0152	-0.0722	-0.3585
0.675	*****	-0.0567	-0.0247	-0.0731	-0.3486
0.700	-0.0851	-0.0670	-0.0276	-0.0767	-0.3488
0.725	*****	-0.0771	*****	-0.0783	-0.3449
0.750	-0.0803	-0.0859	*****	-0.0806	-0.3362
0.775	*****	-0.0934	-0.0555	-0.0899	-0.3274
0.800	-0.0639	-0.0996	-0.0703	-0.0967	*****
0.825	*****	-0.1021	-0.0847	-0.0965	-0.3545
0.850	-0.0490	-0.1038	-0.1001	-0.1257	-0.3552
0.875	*****	-0.0994	-0.1128	-0.1413	-0.4496
0.900	-0.0206	-0.0927	-0.1174	-0.1609	-0.5548
0.925	*****	-0.0774	-0.1133	-0.1672	-1.0253
0.950	0.0239	-0.0466	-0.0924	-0.1512	-0.5420
0.975	*****	0.0020	-0.0460	-0.1048	-0.3074
1.000	0.2039	0.1921	0.1907	0.1447	0.0945
	$C_{p,l}$	$C_{p,l}$	$C_{p,l}$	$C_{p,l}$	$C_{p,l}$
-0.200	0.0022	0.0188	0.0718	*****	-0.3360
-0.400	-0.0202	0.0227	0.0376	-0.0681	-0.3622
-0.600	-0.0337	0.0026	0.0164	-0.0544	-0.3761
-0.700	-0.0285	-0.0252	-0.0002	-0.0548	-0.3863
-0.800	-0.0069	*****	-0.0302	-0.0596	-0.3943
-0.850	*****	-0.0302	-0.0488	-0.0806	-0.4572
-0.900	*****	-0.0066	-0.0478	-0.0983	-0.5734
-0.950	0.1021	0.0421	0.0006	-0.0669	-0.4549
-0.975	*****	0.1019	0.0565	-0.0028	-0.2425
-1.000	0.1909	0.1840	0.1422	0.1536	0.0978

Medium Radius L.E.
 Run No. = 23, Point No. = 461
 $C_N = 0.029$, $C_m = -0.0049$
 $\alpha = 0.8^\circ$, $M_\infty = 0.599$
 $R_{mac} = 59.8 \times 10^6$

Leading Edge Pressures

- starboard
- port

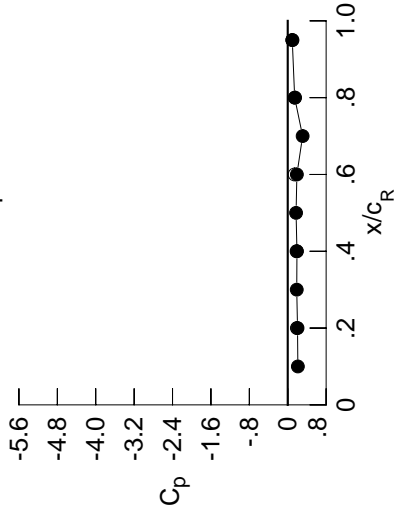

x/c_R	starb'd C_p	port C_p
0.10	0.2111	*****
0.20	0.2039	0.1909
0.30	0.1878	*****
0.40	0.1921	0.1840
0.50	0.1737	*****
0.60	0.1907	0.1422
0.70	0.3103	*****
0.80	0.1447	0.1536
0.90	*****	*****
0.95	0.0945	0.0978

Surface Pressures

- upper, starboard
- lower, port

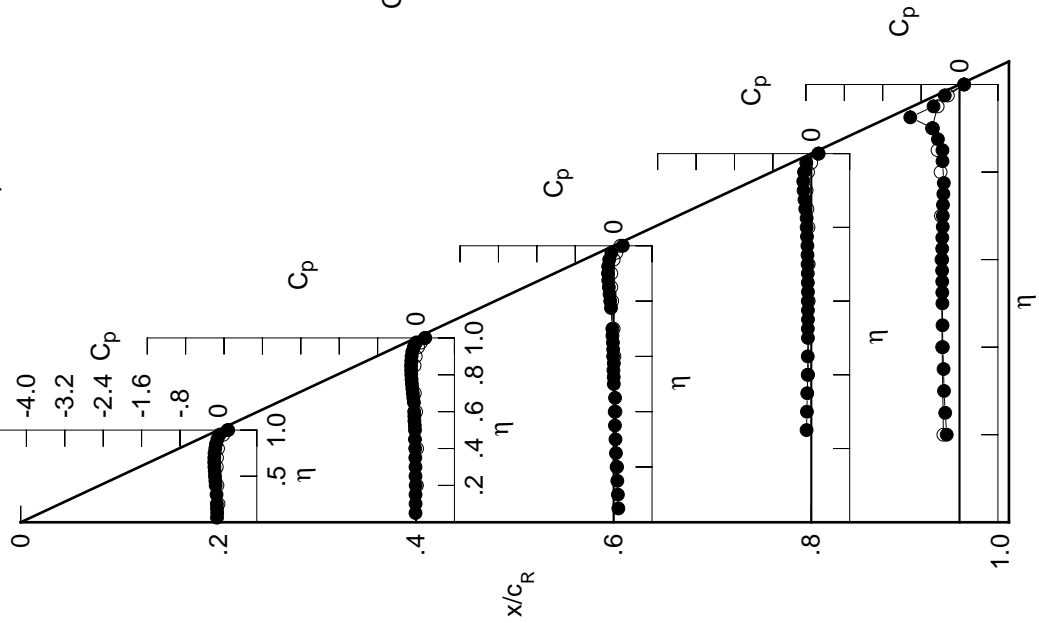

Table D2. Continued.

η	$x/c_R = .2$		$x/c_R = .4$		$x/c_R = .6$		$x/c_R = .8$		$x/c_R = .95$	
	$C_{p,u}$	$C_{p,u}$	$C_{p,u}$	$C_{p,u}$	$C_{p,u}$	$C_{p,u}$	$C_{p,u}$	$C_{p,u}$	$C_{p,u}$	$C_{p,u}$
0.050	-0.0489	-0.0265	0.0862	0.0862	0.0862	0.0862	0.0862	0.0862	0.0862	0.0862
0.100	-0.0446	-0.0265	0.0776	0.0776	0.0776	0.0776	0.0776	0.0776	0.0776	0.0776
0.150	-0.0484	-0.0263	0.0642	0.0642	0.0642	0.0642	0.0642	0.0642	0.0642	0.0642
0.200	-0.0503	-0.0242	0.0495	0.0495	0.0495	0.0495	0.0495	0.0495	0.0495	0.0495
0.250	0.0000	-0.0283	0.0344	0.0344	0.0344	0.0344	0.0344	0.0344	0.0344	0.0344
0.300	-0.0583	-0.0299	0.0258	0.0258	0.0258	0.0258	0.0258	0.0258	0.0258	0.0258
0.350	0.0000	-0.0321	0.0135	0.0135	0.0135	0.0135	0.0135	0.0135	0.0135	0.0135
0.400	-0.0792	-0.0355	0.0078	0.0078	0.0078	0.0078	0.0078	0.0078	0.0078	0.0078
0.450	-0.0877	-0.0414	0.0143	0.0143	0.0143	0.0143	0.0143	0.0143	0.0143	0.0143
0.500	-0.0962	-0.0419	-0.0117	-0.0803	-0.0803	-0.0803	-0.0803	-0.0803	-0.0803	-0.0803
0.525	0.0000	-0.0464	-0.0154	-0.0829	-0.0829	-0.0829	-0.0829	-0.0829	-0.0829	-0.0829
0.550	-0.1042	-0.0552	-0.0191	-0.0806	-0.0806	-0.0806	-0.0806	-0.0806	-0.0806	-0.0806
0.575	0.0000	-0.0585	-0.0138	-0.0831	-0.0831	-0.0831	-0.0831	-0.0831	-0.0831	-0.0831
0.600	-0.1130	-0.0620	-0.0285	-0.0850	-0.0850	-0.0850	-0.0850	-0.0850	-0.0850	-0.0850
0.625	0.0000	0.0000	-0.0282	-0.0830	-0.0830	-0.0830	-0.0830	-0.0830	-0.0830	-0.0830
0.650	-0.1184	-0.0691	-0.0340	-0.0859	-0.0859	-0.0859	-0.0859	-0.0859	-0.0859	-0.0859
0.675	0.0000	-0.0832	-0.0450	-0.0881	-0.0881	-0.0881	-0.0881	-0.0881	-0.0881	-0.0881
0.700	-0.1208	-0.0951	-0.0495	-0.0923	-0.0923	-0.0923	-0.0923	-0.0923	-0.0923	-0.0923
0.725	0.0000	-0.1064	0.0000	-0.0958	-0.0958	-0.0958	-0.0958	-0.0958	-0.0958	-0.0958
0.750	-0.1189	-0.1204	0.0000	-0.0993	-0.0993	-0.0993	-0.0993	-0.0993	-0.0993	-0.0993
0.775	0.0000	-0.1290	-0.0828	-0.1108	-0.1108	-0.1108	-0.1108	-0.1108	-0.1108	-0.1108
0.800	-0.1067	-0.1391	-0.1002	-0.1188	-0.1188	-0.1188	-0.1188	-0.1188	-0.1188	-0.1188
0.825	0.0000	-0.1447	-0.1196	-0.1209	-0.1209	-0.1209	-0.1209	-0.1209	-0.1209	-0.1209
0.850	-0.0950	-0.1500	-0.1393	-0.1553	-0.1553	-0.1553	-0.1553	-0.1553	-0.1553	-0.1553
0.875	0.0000	-0.1517	-0.1583	-0.1767	-0.1767	-0.1767	-0.1767	-0.1767	-0.1767	-0.1767
0.900	-0.0718	-0.1481	-0.1695	-0.2049	-0.2049	-0.2049	-0.2049	-0.2049	-0.2049	-0.2049
0.925	0.0000	-0.1402	-0.1727	-0.2195	-0.2195	-0.2195	-0.2195	-0.2195	-0.2195	-0.2195
0.950	-0.0339	-0.1134	-0.1616	-0.2150	-0.2150	-0.2150	-0.2150	-0.2150	-0.2150	-0.2150
0.975	0.0000	-0.0792	-0.1293	-0.1851	-0.1851	-0.1851	-0.1851	-0.1851	-0.1851	-0.1851
1.000	0.1642	0.1218	0.1044	0.0615	0.0615	0.0615	0.0615	0.0615	0.0615	0.0615
η	$C_{p,l}$	$C_{p,l}$	$C_{p,l}$	$C_{p,l}$	$C_{p,l}$	$C_{p,l}$	$C_{p,l}$	$C_{p,l}$	$C_{p,l}$	$C_{p,l}$
-0.200	0.0192	0.0328	0.0818	0.0818	0.0818	0.0818	0.0818	0.0818	0.0818	0.0818
-0.400	-0.0002	0.0383	0.0484	0.0609	0.0609	0.0609	0.0609	0.0609	0.0609	0.0609
-0.600	-0.0077	0.0220	0.0318	0.0450	0.0450	0.0450	0.0450	0.0450	0.0450	0.0450
-0.700	0.0008	-0.0013	0.0174	-0.0435	-0.0435	-0.0435	-0.0435	-0.0435	-0.0435	-0.0435
-0.800	0.0265	0.0000	-0.0051	-0.0419	-0.0419	-0.0419	-0.0419	-0.0419	-0.0419	-0.0419
-0.850	0.0000	0.0070	-0.0160	-0.0567	-0.0567	-0.0567	-0.0567	-0.0567	-0.0567	-0.0567
-0.900	0.0000	0.0355	-0.0073	-0.0655	-0.0655	-0.0655	-0.0655	-0.0655	-0.0655	-0.0655
-0.950	0.1383	0.0872	0.0485	-0.0202	-0.0202	-0.0202	-0.0202	-0.0202	-0.0202	-0.0202
-0.975	0.0000	0.1445	0.1049	0.0474	0.0474	0.0474	0.0474	0.0474	0.0474	0.0474
-1.000	0.1543	0.1225	0.0686	0.0827	0.0827	0.0827	0.0827	0.0827	0.0827	0.0827

Medium Radius L.E.

Run No. = 23 , Point No. = 462

$C_N = 0.064$, $C_m = -0.0101$

$\alpha = 1.8^\circ$, $M_\infty = 0.599$

$R_{mac} = 59.9 \times 10^6$

Leading Edge Pressures

● starboard
○ port

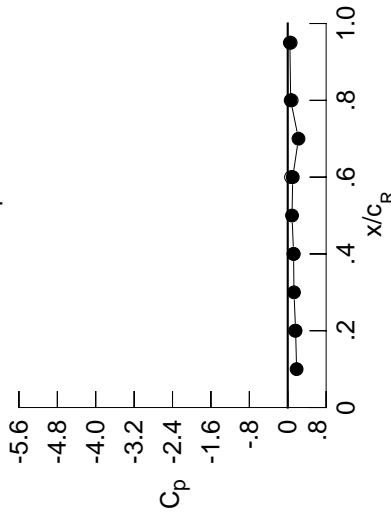

x/c_R	starb'd C_p	port C_p
0.10	0.1847	0.1543
0.20	0.1642	0.1225
0.30	0.1302	0.0894
0.40	0.1218	0.0686
0.50	0.0894	0.0615
0.60	0.1044	0.0827
0.70	0.2240	0.0613
0.80	0.0615	0.0613
0.90	0.0615	0.0613
0.95	0.0446	0.0613

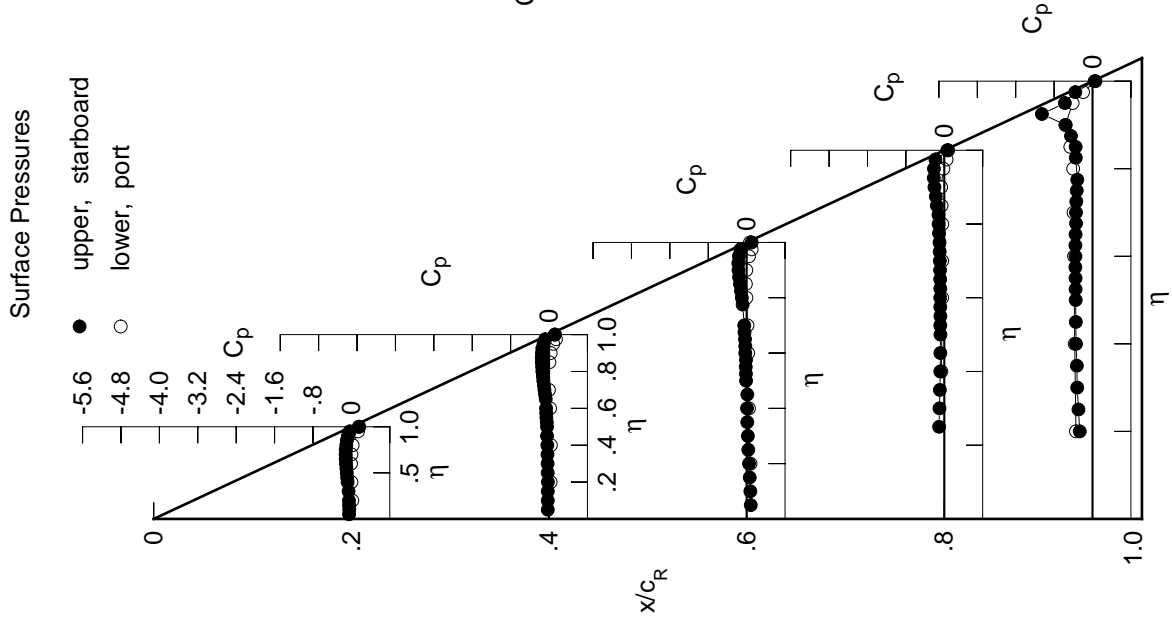

Table D2. Continued.

η	$x/c_R = .2$		$x/c_R = .4$		$x/c_R = .6$		$x/c_R = .8$		$x/c_R = .95$	
	$C_{p,u}$	$C_{p,u}$	$C_{p,u}$	$C_{p,u}$	$C_{p,u}$	$C_{p,u}$	$C_{p,u}$	$C_{p,u}$	$C_{p,u}$	$C_{p,u}$
0.050	-0.0654	-0.0392	0.0774	*****	*****	*****	*****	*****	*****	
0.100	-0.0622	-0.0392	0.0678	*****	*****	*****	*****	*****	*****	
0.150	-0.0659	-0.0393	0.0552	*****	*****	*****	*****	*****	*****	
0.200	-0.0680	-0.0375	0.0399	*****	*****	*****	*****	*****	-0.2630	
0.250	*****	-0.0414	0.0248	-0.1124	-0.1055	-0.3085	*****	*****	-0.2866	
0.300	-0.0769	-0.0440	0.0157	-0.1055	-0.0984	-0.3163	*****	*****	-0.3085	
0.350	*****	-0.0480	0.0018	-0.0984	-0.0882	-0.3318	*****	*****	-0.3163	
0.400	-0.1005	-0.0524	-0.0038	-0.0882	-0.0779	-0.3428	*****	*****	-0.3318	
0.450	-0.1111	-0.0579	0.0025	-0.0895	-0.0872	-0.3393	*****	*****	-0.3428	
0.500	-0.1206	-0.0606	-0.0255	-0.0872	-0.0908	-0.3428	*****	*****	-0.3393	
0.525	*****	-0.0652	-0.0279	-0.0908	-0.0877	-0.3440	*****	*****	-0.3428	
0.550	-0.1303	-0.0753	-0.0334	-0.0877	-0.0922	-0.3468	*****	*****	-0.3440	
0.575	*****	-0.0784	-0.0278	-0.0922	-0.0937	-0.3457	*****	*****	-0.3468	
0.600	-0.1423	-0.0835	-0.0444	-0.0937	-0.0934	-0.3456	*****	*****	-0.3457	
0.625	*****	*****	-0.0440	-0.0934	-0.0965	-0.3435	*****	*****	-0.3456	
0.650	-0.1509	-0.0938	-0.0509	-0.0965	-0.1001	-0.3337	*****	*****	-0.3435	
0.675	*****	-0.1080	-0.0638	-0.1001	-0.1044	-0.3332	*****	*****	-0.3337	
0.700	-0.1567	-0.1236	-0.0693	-0.1044	-0.1091	-0.3272	*****	*****	-0.3332	
0.725	*****	-0.1382	*****	-0.1091	-0.1150	-0.3143	*****	*****	-0.3272	
0.750	-0.1583	-0.1534	*****	-0.1150	-0.1288	-0.3011	*****	*****	-0.3143	
0.775	*****	-0.1654	-0.1099	-0.1288	-0.1407	*****	*****	*****	-0.3011	
0.800	-0.1506	-0.1807	-0.1306	-0.1407	-0.1449	-0.3316	*****	*****	-0.3316	
0.825	*****	-0.1891	-0.1555	-0.1449	-0.1838	-0.3383	*****	*****	-0.3316	
0.850	-0.1440	-0.1998	-0.1806	-0.1838	-0.2135	-0.4393	*****	*****	-0.3383	
0.875	*****	-0.2062	-0.2074	-0.2135	-0.2494	-0.5559	*****	*****	-0.4393	
0.900	-0.1282	-0.2094	-0.2265	-0.2494	-0.2769	-1.0746	*****	*****	-0.5559	
0.925	*****	-0.2081	-0.2395	-0.2769	-0.2842	-0.6092	*****	*****	-1.0746	
0.950	-0.0999	-0.1920	-0.2413	-0.2842	-0.2770	-0.4154	*****	*****	-0.6092	
0.975	*****	-0.1748	-0.2261	-0.2770	-0.0905	-0.0472	*****	*****	-0.4154	
1.000	0.0892	0.0010	-0.0439	-0.0905	-0.0472	*****	*****	*****	-0.0472	
-0.200	$C_{p,l}$	$C_{p,l}$	$C_{p,l}$	$C_{p,l}$	$C_{p,l}$	$C_{p,l}$	$C_{p,l}$	$C_{p,l}$	$C_{p,l}$	
-0.400	0.0420	0.0532	0.0967	*****	*****	-0.3438	*****	*****	-0.3438	
-0.600	0.0243	0.0585	0.0644	-0.0497	-0.3743	*****	*****	*****	-0.3743	
-0.700	0.0219	0.0456	0.0494	-0.0309	-0.3873	*****	*****	*****	-0.3873	
-0.800	0.0344	0.0271	0.0394	-0.0260	-0.3992	*****	*****	*****	-0.3992	
-0.850	0.0637	*****	0.0241	-0.0200	-0.4061	*****	*****	*****	-0.4061	
-0.900	*****	0.0471	0.0193	-0.0288	-0.4624	*****	*****	*****	-0.4624	
-0.950	*****	0.0794	0.0350	-0.0256	-0.5495	*****	*****	*****	-0.5495	
-0.975	0.1729	0.1296	0.0944	0.0261	-0.3715	*****	*****	*****	-0.3715	
-1.000	*****	0.1787	0.1457	0.0924	-0.1495	*****	*****	*****	-0.1495	
	0.0840	0.0080	-0.0752	-0.0575	-0.0122	*****	*****	*****	-0.0122	

Medium Radius L.E.
 Run No. = 23 , Point No. = 463
 $C_N = 0.095$, $C_m = -0.0109$
 $\alpha = 2.8^\circ$, $M_\infty = 0.599$
 $R_{mac} = 59.8 \times 10^6$

Leading Edge Pressures

● starboard
 ○ port

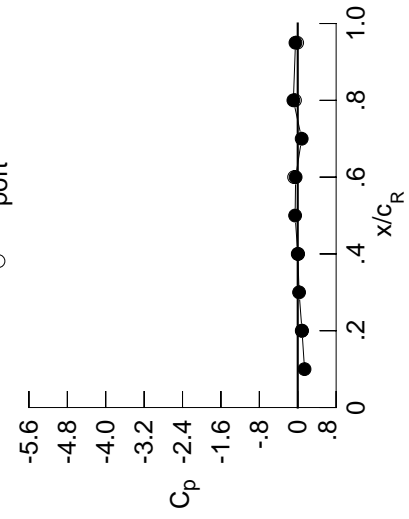

x/c_R	starb'd C_p	port C_p
0.10	0.1416	*****
0.20	0.0892	0.0840
0.30	0.0282	*****
0.40	0.0010	0.0080
0.50	-0.0545	*****
0.60	-0.0439	-0.0752
0.70	0.0824	*****
0.80	-0.0905	-0.0575
0.90	*****	*****
0.95	-0.0472	-0.0122

Surface Pressures

● upper, starboard
 ○ lower, port

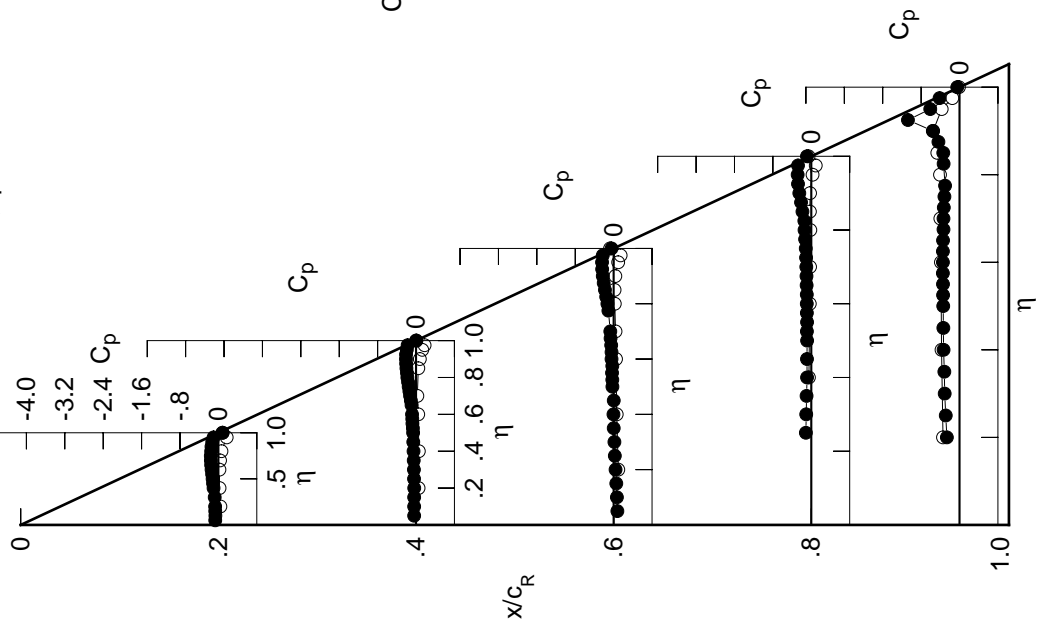

Table D2. Continued.

η	$x/c_R = .2$		$x/c_R = .4$		$x/c_R = .6$		$x/c_R = .8$		$x/c_R = .95$	
	$C_{p,u}$	$C_{p,u}$	$C_{p,u}$	$C_{p,u}$	$C_{p,u}$	$C_{p,u}$	$C_{p,u}$	$C_{p,u}$	$C_{p,u}$	$C_{p,u}$
0.050	-0.0845	-0.0562	0.0660	0.0660	0.0660	0.0660	0.0660	0.0660	0.0660	0.0660
0.100	-0.0806	-0.0542	0.0580	0.0580	0.0580	0.0580	0.0580	0.0580	0.0580	0.0580
0.150	-0.0850	-0.0545	0.0449	0.0449	0.0449	0.0449	0.0449	0.0449	0.0449	0.0449
0.200	-0.0861	-0.0545	0.0280	0.0280	0.0280	0.0280	0.0280	0.0280	0.0280	0.0280
0.250	*****	-0.0575	0.0136	0.0136	0.0136	0.0136	0.0136	0.0136	0.0136	0.0136
0.300	-0.0961	-0.0614	0.0035	0.0035	0.0035	0.0035	0.0035	0.0035	0.0035	0.0035
0.350	*****	-0.0648	-0.0084	-0.1073	-0.3092	-0.16	-0.16	-0.16	-0.16	-0.16
0.400	-0.1219	-0.0697	-0.0177	-0.0966	-0.3254	-0.8	-0.8	-0.8	-0.8	-0.8
0.450	-0.1347	-0.0769	-0.0105	-0.0982	-0.3295	-1.6	-1.6	-1.6	-1.6	-1.6
0.500	-0.1471	-0.0801	-0.0410	-0.0962	-0.3339	-2.4	-2.4	-2.4	-2.4	-2.4
0.525	*****	-0.0863	-0.0433	-0.1002	-0.3355	-3.2	-3.2	-3.2	-3.2	-3.2
0.550	-0.1598	-0.0950	-0.0486	-0.0987	-0.3361	-4.0	-4.0	-4.0	-4.0	-4.0
0.575	*****	-0.1019	-0.0453	-0.1022	-0.3392	-4.8	-4.8	-4.8	-4.8	-4.8
0.600	-0.1734	-0.1064	-0.0615	-0.1067	-0.3381	-5.6	-5.6	-5.6	-5.6	-5.6
0.625	*****	*****	-0.0634	-0.1053	-0.3383	-5.6	-5.6	-5.6	-5.6	-5.6
0.650	-0.1855	-0.1179	-0.0698	-0.1098	-0.3348	-5.6	-5.6	-5.6	-5.6	-5.6
0.675	*****	-0.1368	-0.0848	-0.1136	-0.3267	-5.6	-5.6	-5.6	-5.6	-5.6
0.700	-0.1949	-0.1516	-0.0922	-0.1213	-0.3239	-5.6	-5.6	-5.6	-5.6	-5.6
0.725	*****	-0.1708	*****	-0.1260	-0.3177	-5.6	-5.6	-5.6	-5.6	-5.6
0.750	-0.2009	-0.1873	*****	-0.1359	-0.3028	-5.6	-5.6	-5.6	-5.6	-5.6
0.775	*****	-0.2052	-0.1396	-0.1491	-0.2866	-5.6	-5.6	-5.6	-5.6	-5.6
0.800	-0.1981	-0.2237	-0.1638	-0.1659	*****	-5.6	-5.6	-5.6	-5.6	-5.6
0.825	*****	-0.2371	-0.1937	-0.1723	-0.3128	-5.6	-5.6	-5.6	-5.6	-5.6
0.850	-0.1975	-0.2536	-0.2263	-0.2153	-0.3276	-5.6	-5.6	-5.6	-5.6	-5.6
0.875	*****	-0.2644	-0.2576	-0.2530	-0.4318	-5.6	-5.6	-5.6	-5.6	-5.6
0.900	-0.1900	-0.2765	-0.2885	-0.3001	-0.5533	-5.6	-5.6	-5.6	-5.6	-5.6
0.925	*****	-0.2831	-0.3114	-0.3379	-1.0897	-5.6	-5.6	-5.6	-5.6	-5.6
0.950	-0.1748	-0.2793	-0.3291	-0.3642	-0.6482	-5.6	-5.6	-5.6	-5.6	-5.6
0.975	*****	-0.2832	-0.3397	-0.3814	-0.4820	-5.6	-5.6	-5.6	-5.6	-5.6
1.000	-0.0176	-0.1646	-0.2625	-0.3133	-0.1864	-5.6	-5.6	-5.6	-5.6	-5.6
-0.200	$C_{p,l}$	0.0617	0.0687	0.1086	*****	-0.3477	-0.3477	-0.3477	-0.3477	-0.3477
-0.400	$C_{p,l}$	0.0468	0.0751	0.0774	-0.0399	-0.3820	-0.3820	-0.3820	-0.3820	-0.3820
-0.600	$C_{p,l}$	0.0495	0.0667	0.0669	-0.0204	-0.3967	-0.3967	-0.3967	-0.3967	-0.3967
-0.700	$C_{p,l}$	0.0651	0.0519	0.0584	-0.0130	-0.4069	-0.4069	-0.4069	-0.4069	-0.4069
-0.800	$C_{p,l}$	0.0965	*****	0.0488	-0.0010	-0.4138	-0.4138	-0.4138	-0.4138	-0.4138
-0.850	$C_{p,l}$	*****	0.0813	0.0501	-0.0049	-0.4647	-0.4647	-0.4647	-0.4647	-0.4647
-0.900	$C_{p,l}$	*****	0.1169	0.0713	0.0070	-0.5361	-0.5361	-0.5361	-0.5361	-0.5361
-0.950	$C_{p,l}$	0.1986	0.1629	0.1296	0.0635	-0.3347	-0.3347	-0.3347	-0.3347	-0.3347
-0.975	$C_{p,l}$	*****	0.1986	0.1713	0.1239	-0.1114	-0.1114	-0.1114	-0.1114	-0.1114
-1.000	$C_{p,l}$	-0.0286	-0.1584	-0.2935	-0.2695	-0.1363	-0.1363	-0.1363	-0.1363	-0.1363

Medium Radius L.E.

Run No. = 23 , Point No. = 464

$C_N = 0.132$, $C_m = -0.0161$

$\alpha = 3.8^\circ$, $M_\infty = 0.598$

$R_{mac} = 59.9 \times 10^6$

Leading Edge Pressures

● starboard
○ port

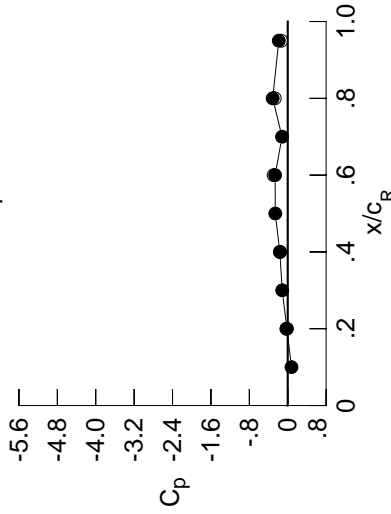

x/c_R	starb'd C_p	port C_p
0.10	0.0788	*****
0.20	-0.0176	-0.0286
0.30	-0.1147	*****
0.40	-0.1646	-0.1584
0.50	-0.2594	*****
0.60	-0.2625	-0.2935
0.70	-0.1184	*****
0.80	-0.3133	-0.2695
0.90	*****	*****
0.95	-0.1864	-0.1363

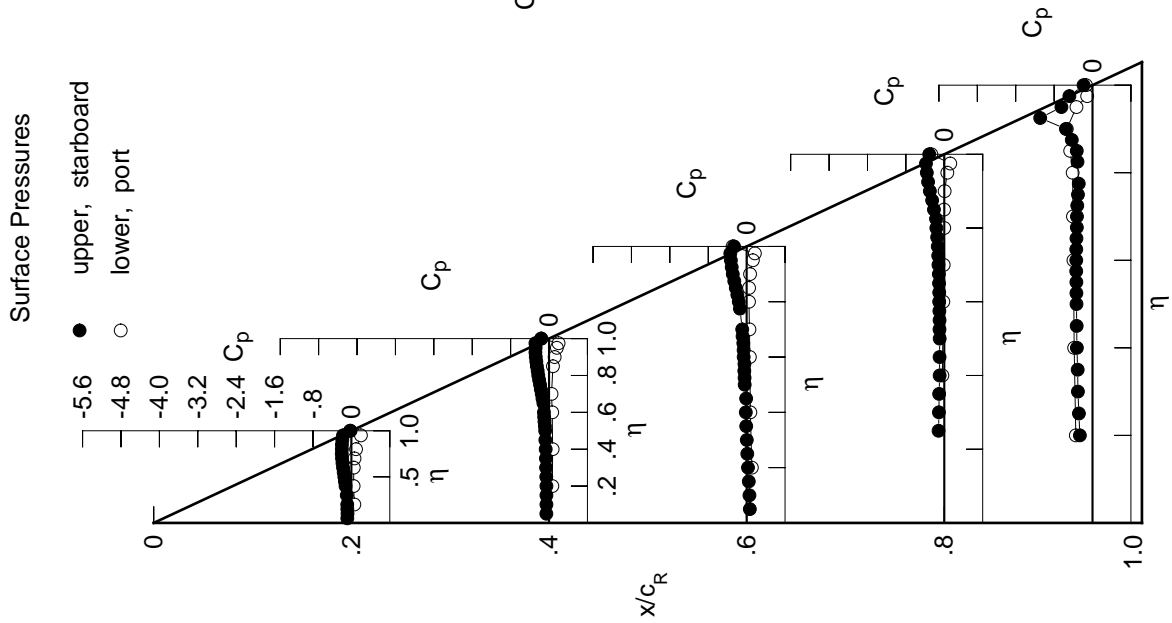

Table D2. Continued.

η	$x/c_R = .2$		$x/c_R = .4$		$x/c_R = .6$		$x/c_R = .8$		$x/c_R = .95$	
	$C_{p,u}$	$C_{p,u}$	$C_{p,u}$	$C_{p,u}$	$C_{p,u}$	$C_{p,u}$	$C_{p,u}$	$C_{p,u}$	$C_{p,u}$	$C_{p,u}$
0.050	-0.1018	-0.0687	0.0586	*****	*****	*****	*****	*****	*****	*****
0.100	-0.0986	-0.0687	0.0480	*****	*****	*****	*****	*****	*****	*****
0.150	-0.1029	-0.0695	0.0351	*****	*****	*****	*****	*****	*****	*****
0.200	-0.1064	-0.0689	0.0192	*****	*****	*****	*****	*****	*****	*****
0.250	*****	-0.0733	0.0030	-0.1258	-0.2771	*****	*****	*****	*****	*****
0.300	-0.1173	-0.0772	-0.0078	-0.1182	-0.2940	*****	*****	*****	*****	*****
0.350	*****	-0.0815	-0.0202	-0.1131	-0.3002	*****	*****	*****	*****	*****
0.400	-0.1451	-0.0870	-0.0298	-0.1037	-0.3151	*****	*****	*****	*****	*****
0.450	-0.1590	-0.0951	-0.0245	-0.1053	-0.3203	*****	*****	*****	*****	*****
0.500	-0.1730	-0.0989	-0.0536	-0.1042	-0.3256	*****	*****	*****	*****	*****
0.525	*****	-0.1065	-0.0580	-0.1092	-0.3279	*****	*****	*****	*****	*****
0.550	-0.1888	-0.1171	-0.0646	-0.1081	-0.3292	*****	*****	*****	*****	*****
0.575	*****	-0.1231	-0.0609	-0.1136	-0.3318	*****	*****	*****	*****	*****
0.600	-0.2047	-0.1313	-0.0794	-0.1170	-0.3305	*****	*****	*****	*****	*****
0.625	*****	*****	-0.0809	-0.1173	-0.3304	*****	*****	*****	*****	*****
0.650	-0.2210	-0.1438	-0.0895	-0.1229	-0.3290	*****	*****	*****	*****	*****
0.675	*****	-0.1638	-0.1057	-0.1279	-0.3185	*****	*****	*****	*****	*****
0.700	-0.2345	-0.1827	-0.1146	-0.1355	-0.3158	*****	*****	*****	*****	*****
0.725	*****	-0.2038	*****	-0.1436	-0.3075	*****	*****	*****	*****	*****
0.750	-0.2448	-0.2253	*****	-0.1540	-0.2896	*****	*****	*****	*****	*****
0.775	*****	-0.2447	-0.1685	-0.1710	-0.2685	*****	*****	*****	*****	*****
0.800	-0.2483	-0.2681	-0.1983	-0.1892	*****	*****	*****	*****	*****	*****
0.825	*****	-0.2877	-0.2327	-0.1984	-0.2934	*****	*****	*****	*****	*****
0.850	-0.2549	-0.3098	-0.2717	-0.2489	-0.3097	*****	*****	*****	*****	*****
0.875	*****	-0.3285	-0.3133	-0.2937	-0.4166	*****	*****	*****	*****	*****
0.900	-0.2562	-0.3480	-0.3533	-0.3509	-0.5478	*****	*****	*****	*****	*****
0.925	*****	-0.3657	-0.3902	-0.4046	-1.0953	*****	*****	*****	*****	*****
0.950	-0.2580	-0.3764	-0.4256	-0.4491	-0.6897	*****	*****	*****	*****	*****
0.975	*****	-0.4084	-0.4665	-0.5004	-0.5566	*****	*****	*****	*****	*****
1.000	-0.1552	-0.3865	-0.5454	-0.6128	-0.3741	*****	*****	*****	*****	*****
-0.200	$C_{p,l}$	$C_{p,l}$	$C_{p,l}$	$C_{p,l}$	$C_{p,l}$	$C_{p,l}$	$C_{p,l}$	$C_{p,l}$	$C_{p,l}$	$C_{p,l}$
-0.400	0.0825	0.0853	0.1210	*****	*****	*****	*****	*****	*****	*****
-0.600	0.0698	0.0941	0.0920	-0.0301	-0.3871	*****	*****	*****	*****	*****
-0.700	0.0768	0.0873	0.0828	-0.0076	-0.4026	*****	*****	*****	*****	*****
-0.800	0.0943	0.0773	0.0780	0.0021	-0.4132	*****	*****	*****	*****	*****
-0.850	0.1273	*****	0.0733	0.0170	-0.4179	*****	*****	*****	*****	*****
-0.900	*****	0.1138	0.0784	0.0183	-0.4648	*****	*****	*****	*****	*****
-0.950	0.2162	0.1867	0.1571	0.0946	-0.2992	*****	*****	*****	*****	*****
-0.975	*****	0.2033	0.1849	0.1440	-0.0814	*****	*****	*****	*****	*****
-1.000	-0.1701	-0.3745	-0.5824	-0.5517	-0.3047	*****	*****	*****	*****	*****

Medium Radius L.E.
 Run No. = 23 , Point No. = 465
 $C_N = 0.171$, $C_m = -0.0224$
 $\alpha = 4.9^\circ$, $M_\infty = 0.599$
 $R_{mac} = 59.8 \times 10^6$

Leading Edge Pressures

● starboard
 ○ port

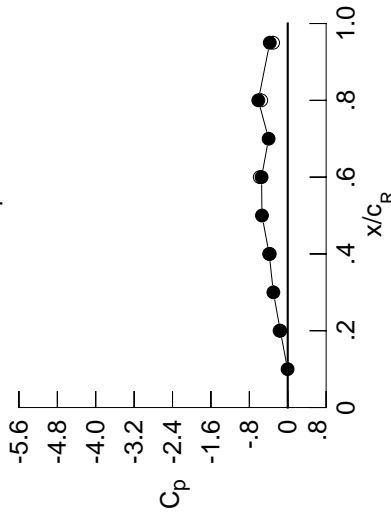

x/c_R	starb'd C_p	port C_p
0.10	-0.0032	*****
0.20	-0.1552	-0.1701
0.30	-0.2992	*****
0.40	-0.3865	-0.3745
0.50	-0.5367	*****
0.60	-0.5454	-0.5824
0.70	-0.3984	*****
0.80	-0.6128	-0.5517
0.90	*****	*****
0.95	-0.3741	-0.3047

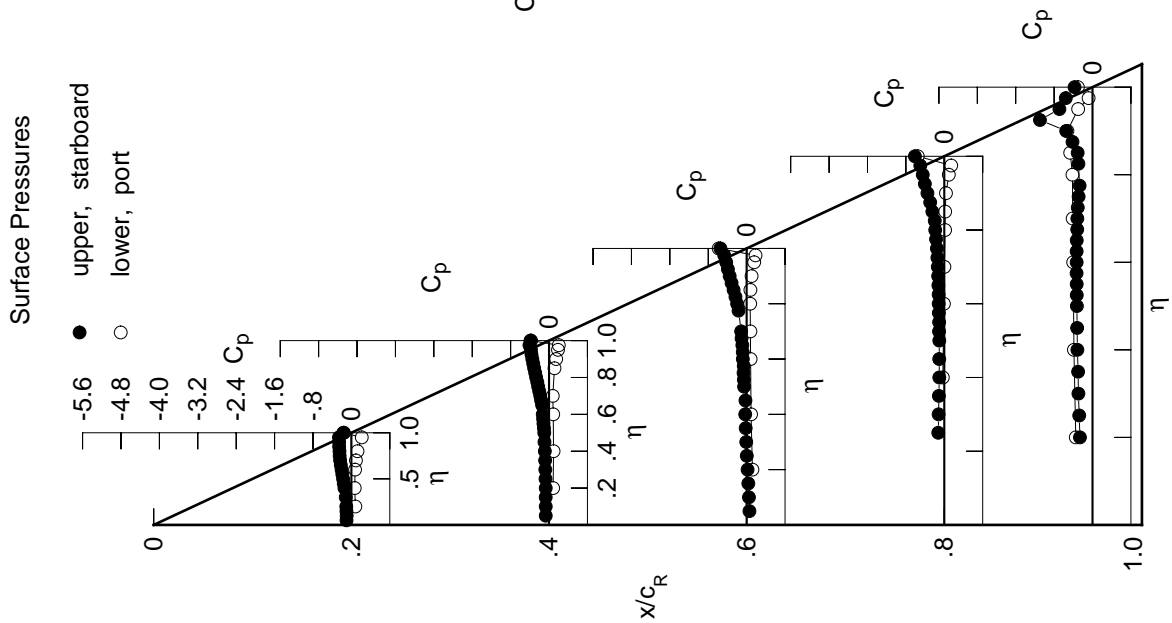

Table D2. Continued.

η	$x/c_R = 0.2$		$x/c_R = 0.4$		$x/c_R = 0.6$		$x/c_R = 0.8$		$x/c_R = 0.95$	
	$C_{p,u}$	$C_{p,u}$	$C_{p,u}$	$C_{p,u}$	$C_{p,u}$	$C_{p,u}$	$C_{p,u}$	$C_{p,u}$	$C_{p,u}$	$C_{p,u}$
0.050	-0.1175	-0.0807	0.0501	0.0501	0.0501	0.0501	0.0501	0.0501	0.0501	0.0501
0.100	-0.1156	-0.0810	0.0395	0.0395	0.0395	0.0395	0.0395	0.0395	0.0395	0.0395
0.150	-0.1200	-0.0827	0.0267	0.0267	0.0267	0.0267	0.0267	0.0267	0.0267	0.0267
0.200	-0.1228	-0.0816	0.0094	0.0094	0.0094	0.0094	0.0094	0.0094	0.0094	0.0094
0.250	0.0000	-0.0868	-0.0059	-0.0059	-0.1305	-0.1305	-0.2706	-0.2706	-0.2706	-0.2706
0.300	-0.1347	-0.0910	-0.0170	-0.0170	-0.1232	-0.1232	-0.2864	-0.2864	-0.2864	-0.2864
0.350	0.0000	-0.0960	-0.0305	-0.0305	-0.1183	-0.1183	-0.2911	-0.2911	-0.2911	-0.2911
0.400	-0.1653	-0.1026	-0.0405	-0.0405	-0.1091	-0.1091	-0.3071	-0.3071	-0.3071	-0.3071
0.450	-0.1816	-0.1113	-0.0369	-0.0369	-0.1119	-0.1119	-0.3133	-0.3133	-0.3133	-0.3133
0.500	-0.1977	-0.1179	-0.0662	-0.0662	-0.1116	-0.1116	-0.3174	-0.3174	-0.3174	-0.3174
0.525	0.0000	-0.1252	-0.0715	-0.0715	-0.1161	-0.1161	-0.3212	-0.3212	-0.3212	-0.3212
0.550	-0.2160	-0.1360	-0.0782	-0.0782	-0.1181	-0.1181	-0.3205	-0.3205	-0.3205	-0.3205
0.575	0.0000	-0.1449	-0.0767	-0.0767	-0.1216	-0.1216	-0.3228	-0.3228	-0.3228	-0.3228
0.600	-0.2350	-0.1536	-0.0950	-0.0950	-0.1275	-0.1275	-0.3215	-0.3215	-0.3215	-0.3215
0.625	0.0000	0.0000	-0.0988	-0.0988	-0.1264	-0.1264	-0.3203	-0.3203	-0.3203	-0.3203
0.650	-0.2551	-0.1676	-0.1080	-0.1080	-0.1334	-0.1334	-0.3180	-0.3180	-0.3180	-0.3180
0.675	0.0000	-0.1914	-0.1252	-0.1252	-0.1406	-0.1406	-0.3084	-0.3084	-0.3084	-0.3084
0.700	-0.2731	-0.2112	-0.1363	-0.1363	-0.1496	-0.1496	-0.3053	-0.3053	-0.3053	-0.3053
0.725	0.0000	-0.2351	0.0000	0.0000	-0.1585	-0.1585	-0.2955	-0.2955	-0.2955	-0.2955
0.750	-0.2890	-0.2589	0.0000	0.0000	-0.1724	-0.1724	-0.2754	-0.2754	-0.2754	-0.2754
0.775	0.0000	-0.2846	-0.1971	-0.1971	-0.1910	-0.1910	-0.2501	-0.2501	-0.2501	-0.2501
0.800	-0.2986	-0.3124	-0.2304	-0.2304	-0.2124	-0.2124	0.0000	0.0000	0.0000	0.0000
0.825	0.0000	-0.3369	-0.2702	-0.2702	-0.2243	-0.2243	-0.2655	-0.2655	-0.2655	-0.2655
0.850	-0.3127	-0.3656	-0.3161	-0.3161	-0.2798	-0.2798	-0.2895	-0.2895	-0.2895	-0.2895
0.875	0.0000	-0.3920	-0.3667	-0.3667	-0.3326	-0.3326	-0.3972	-0.3972	-0.3972	-0.3972
0.900	-0.3256	-0.4205	-0.4189	-0.4189	-0.4013	-0.4013	-0.5330	-0.5330	-0.5330	-0.5330
0.925	0.0000	-0.4501	-0.4696	-0.4696	-0.4689	-0.4689	-1.0774	-1.0774	-1.0774	-1.0774
0.950	-0.3484	-0.4776	-0.5260	-0.5260	-0.5362	-0.5362	-0.7216	-0.7216	-0.7216	-0.7216
0.975	0.0000	-0.5414	-0.6038	-0.6038	-0.6234	-0.6234	-0.6270	-0.6270	-0.6270	-0.6270
1.000	-0.3255	-0.6574	-0.8904	-0.8904	-0.9769	-0.9769	-0.6014	-0.6014	-0.6014	-0.6014
$C_{p,l}$	$C_{p,l}$	$C_{p,l}$	$C_{p,l}$	$C_{p,l}$	$C_{p,l}$	$C_{p,l}$	$C_{p,l}$	$C_{p,l}$	$C_{p,l}$	$C_{p,l}$
-0.200	0.1040	0.1043	0.1363	0.1363	0.1363	0.1363	-0.3480	-0.3480	-0.3480	-0.3480
-0.400	0.0940	0.1134	0.1073	0.1073	-0.0174	-0.0174	-0.3905	-0.3905	-0.3905	-0.3905
-0.600	0.1045	0.1096	0.1011	0.1011	0.0057	0.0057	-0.4086	-0.4086	-0.4086	-0.4086
-0.700	0.1240	0.1025	0.0981	0.0981	0.0173	0.0173	-0.4194	-0.4194	-0.4194	-0.4194
-0.800	0.1566	0.0000	0.0983	0.0983	0.0375	0.0375	-0.4213	-0.4213	-0.4213	-0.4213
-0.850	0.0000	0.1443	0.1068	0.1068	0.0410	0.0410	-0.4644	-0.4644	-0.4644	-0.4644
-0.900	0.0000	0.1774	0.1333	0.1333	0.0631	0.0631	-0.5087	-0.5087	-0.5087	-0.5087
-0.950	0.2282	0.2052	0.1800	0.1800	0.1220	0.1220	-0.2676	-0.2676	-0.2676	-0.2676
-0.975	0.0000	0.2025	0.1888	0.1888	0.1565	0.1565	-0.0563	-0.0563	-0.0563	-0.0563
-1.000	-0.3429	-0.6523	-0.9722	-0.9722	-0.9134	-0.9134	-0.5294	-0.5294	-0.5294	-0.5294

Medium Radius L.E.

Run No. = 23 , Point No. = 466

$C_N = 0.205$, $C_m = -0.0253$

$\alpha = 5.9^\circ$, $M_\infty = 0.599$

$R_{mac} = 59.8 \times 10^6$

Leading Edge Pressures

● starboard
○ port

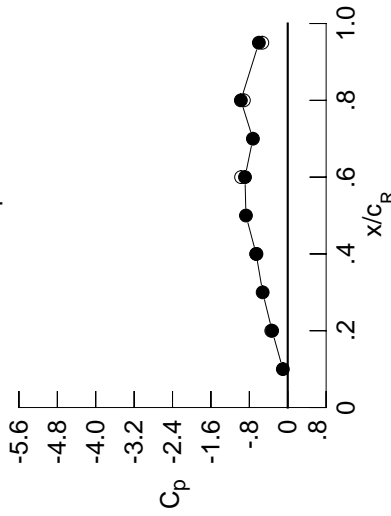

x/c_R	starb'd C_p	port C_p
0.10	-0.1015	0.0000
0.20	-0.3255	-0.3429
0.30	-0.5223	0.0000
0.40	-0.6574	-0.6523
0.50	-0.8707	0.0000
0.60	-0.8904	-0.9722
0.70	-0.7256	0.0000
0.80	-0.9769	-0.9134
0.90	0.0000	0.0000
0.95	-0.6014	-0.5294

Surface Pressures

● upper, starboard
○ lower, port

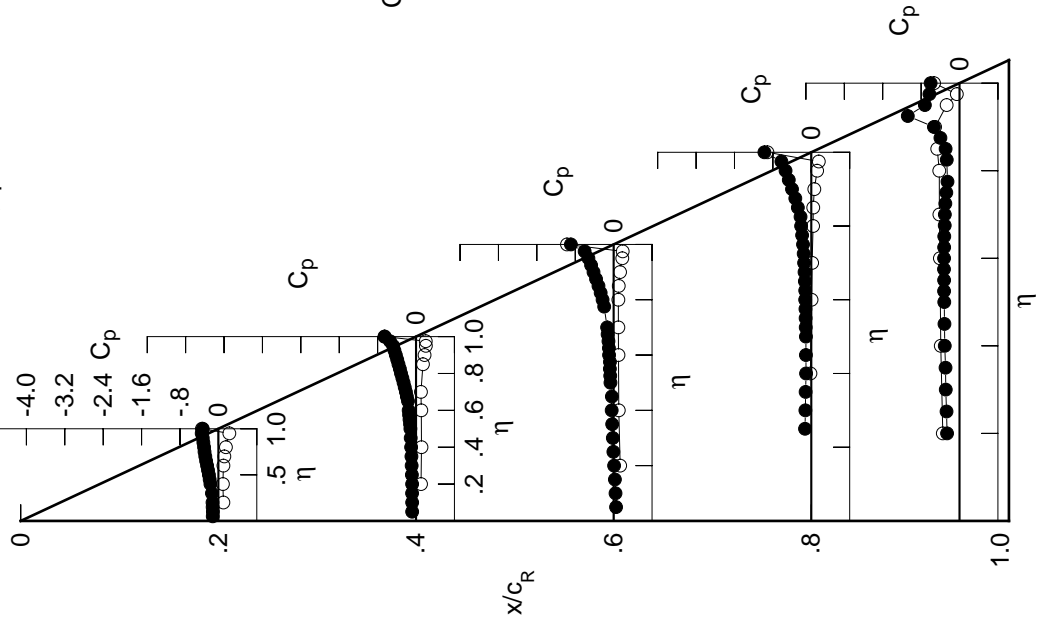
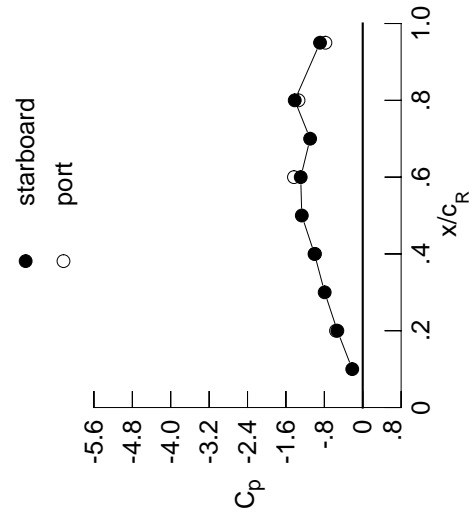

Table D2. Continued.

η	$x/c_R = .2$		$x/c_R = .4$		$x/c_R = .6$		$x/c_R = .8$		$x/c_R = .95$	
	$C_{p,u}$	$C_{p,u}$	$C_{p,u}$	$C_{p,u}$	$C_{p,u}$	$C_{p,u}$	$C_{p,u}$	$C_{p,u}$	$C_{p,u}$	$C_{p,u}$
0.050	-0.1325	-0.0929	0.0430	*****	*****	*****	*****	*****	*****	
0.100	-0.1331	-0.0932	0.0307	*****	*****	*****	*****	*****	*****	
0.150	-0.1376	-0.0961	0.0180	*****	*****	*****	*****	*****	*****	
0.200	-0.1414	-0.0951	0.0012	*****	*****	*****	*****	*****	-0.2642	
0.250	*****	-0.1011	-0.0148	-0.1347	-0.2687	*****	*****	*****	*****	
0.300	-0.1532	-0.1057	-0.0265	-0.1272	-0.2809	*****	*****	*****	*****	
0.350	*****	-0.1110	-0.0406	-0.1230	-0.2845	*****	*****	*****	*****	
0.400	-0.1861	-0.1187	-0.0510	-0.1146	-0.2989	*****	*****	*****	*****	
0.450	-0.2044	-0.1291	-0.0488	-0.1181	-0.3051	*****	*****	*****	*****	
0.500	-0.2224	-0.1370	-0.0791	-0.1185	-0.3110	*****	*****	*****	*****	
0.525	*****	-0.1451	-0.0852	-0.1243	-0.3141	*****	*****	*****	*****	
0.550	-0.2434	-0.1579	-0.0930	-0.1254	-0.3136	*****	*****	*****	*****	
0.575	*****	-0.1665	-0.0925	-0.1317	-0.3172	*****	*****	*****	*****	
0.600	-0.2658	-0.1771	-0.1118	-0.1364	-0.3146	*****	*****	*****	*****	
0.625	*****	*****	-0.1171	-0.1383	-0.3142	*****	*****	*****	*****	
0.650	-0.2899	-0.1937	-0.1267	-0.1462	-0.3113	*****	*****	*****	*****	
0.675	*****	-0.2183	-0.1457	-0.1531	-0.3029	*****	*****	*****	*****	
0.700	-0.3127	-0.2410	-0.1588	-0.1647	-0.2985	*****	*****	*****	*****	
0.725	*****	-0.2666	*****	-0.1760	-0.2916	*****	*****	*****	*****	
0.750	-0.3341	-0.2959	*****	-0.1921	-0.2708	*****	*****	*****	*****	
0.775	*****	-0.3241	-0.2276	-0.2135	-0.2449	*****	*****	*****	*****	
0.800	-0.3506	-0.3579	-0.2639	-0.2355	*****	*****	*****	*****	*****	
0.825	*****	-0.3886	-0.3088	-0.2508	-0.2491	*****	*****	*****	*****	
0.850	-0.3734	-0.4237	-0.3623	-0.3113	-0.2719	*****	*****	*****	*****	
0.875	*****	-0.4590	-0.4222	-0.3725	-0.3755	*****	*****	*****	*****	
0.900	-0.3987	-0.4971	-0.4858	-0.4536	-0.5144	*****	*****	*****	*****	
0.925	*****	-0.5409	-0.5534	-0.5371	-1.0337	*****	*****	*****	*****	
0.950	-0.4446	-0.5870	-0.6332	-0.6269	-0.7489	*****	*****	*****	*****	
0.975	*****	-0.6920	-0.7531	-0.7569	-0.6991	*****	*****	*****	*****	
1.000	-0.5287	-1.0050	-1.2918	-1.4170	-0.8896	*****	*****	*****	*****	
	$C_{p,l}$	$C_{p,l}$	$C_{p,l}$	$C_{p,l}$	$C_{p,l}$	$C_{p,l}$	$C_{p,l}$	$C_{p,l}$	$C_{p,l}$	
-0.200	0.1265	0.1241	0.1508	*****	-0.3481	*****	*****	*****	*****	
-0.400	0.1178	0.1332	0.1240	-0.0064	-0.3926	*****	*****	*****	*****	
-0.600	0.1315	0.1324	0.1183	0.0192	-0.4109	*****	*****	*****	*****	
-0.700	0.1525	0.1270	0.1178	0.0328	-0.4221	*****	*****	*****	*****	
-0.800	0.1838	*****	0.1213	0.0547	-0.4228	*****	*****	*****	*****	
-0.850	*****	0.1714	0.1319	0.0620	-0.4610	*****	*****	*****	*****	
-0.900	*****	0.2015	0.1584	0.0882	-0.4939	*****	*****	*****	*****	
-0.950	0.2325	0.2159	0.1949	0.1419	-0.2388	*****	*****	*****	*****	
-0.975	*****	0.1878	0.1814	0.1583	-0.0377	*****	*****	*****	*****	
-1.000	-0.5569	-0.9948	-1.4332	-1.3376	-0.7779	*****	*****	*****	*****	

Medium Radius L.E.
 Run No. = 23 , Point No. = 467
 $C_N = 0.243$, $C_m = -0.0313$
 $\alpha = 7.0^\circ$, $M_\infty = 0.597$
 $R_{mac} = 59.7 \times 10^6$

Leading Edge Pressures



x/c_R	starb'd C_p	port C_p
0.10	-0.2180	*****
0.20	-0.5287	-0.5569
0.30	-0.7929	*****
0.40	-1.0050	-0.9948
0.50	-1.2698	*****
0.60	-1.2918	-1.4332
0.70	-1.0956	*****
0.80	-1.4170	-1.3376
0.90	*****	*****
0.95	-0.8896	-0.7779

Surface Pressures

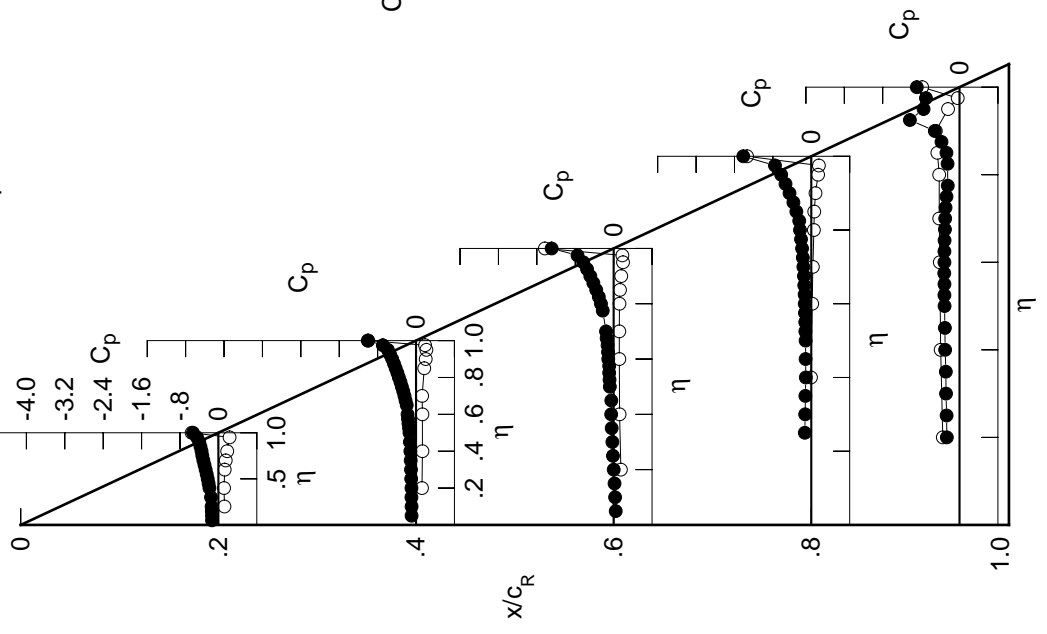
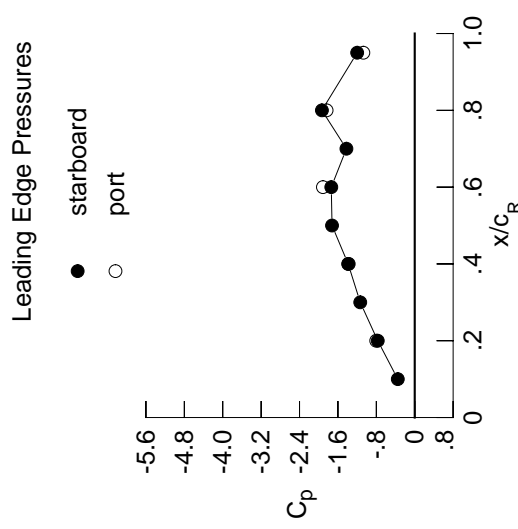

Table D2. Continued.

η	$x/c_R = 0.2$		$x/c_R = 0.4$		$x/c_R = 0.6$		$x/c_R = 0.8$		$x/c_R = 0.95$	
	$C_{p,u}$	$C_{p,u}$	$C_{p,u}$	$C_{p,u}$	$C_{p,u}$	$C_{p,u}$	$C_{p,u}$	$C_{p,u}$	$C_{p,u}$	$C_{p,u}$
0.050	-0.1464	-0.1039	0.0344	*****	*****	*****	*****	*****	*****	*****
0.100	-0.1493	-0.1062	0.0242	*****	*****	*****	*****	*****	*****	*****
0.150	-0.1541	-0.1080	0.0097	*****	*****	*****	*****	*****	*****	*****
0.200	-0.1589	-0.1085	-0.0076	*****	*****	*****	*****	*****	*****	-0.2696
0.250	*****	-0.1146	-0.0244	-0.1402	-0.1402	-0.1402	-0.2697			
0.300	-0.1717	-0.1194	-0.0355	-0.1330	-0.1330	-0.2780				
0.350	*****	-0.1271	-0.0507	-0.1285	-0.1285	-0.2796				
0.400	-0.2070	-0.1344	-0.0622	-0.1210	-0.1210	-0.2936				
0.450	-0.2269	-0.1467	-0.0612	-0.1252	-0.1252	-0.2996				
0.500	-0.2473	-0.1551	-0.0926	-0.1266	-0.1266	-0.3078				
0.525	*****	-0.1657	-0.1003	-0.1332	-0.1332	-0.3132				
0.550	-0.2705	-0.1790	-0.1086	-0.1331	-0.1310	-0.3150				
0.575	*****	-0.1893	-0.1081	-0.1404	-0.3198					
0.600	-0.2970	-0.1996	-0.1295	-0.1466	-0.3182					
0.625	*****	*****	-0.1353	-0.1493	-0.3208					
0.650	-0.3248	-0.2199	-0.1467	-0.1591	-0.3223					
0.675	*****	-0.2457	-0.1675	-0.1692	-0.3162					
0.700	-0.3526	-0.2707	-0.1824	-0.1809	-0.3106					
0.725	*****	-0.2989	*****	-0.1940	-0.3040					
0.750	-0.3803	-0.3307	*****	-0.2167	-0.2812					
0.775	*****	-0.3646	-0.2595	-0.2457	-0.2430					
0.800	-0.4041	-0.4027	-0.2996	-0.2709	*****					
0.825	*****	-0.4410	-0.3476	-0.2894	-0.2050					
0.850	-0.4364	-0.4827	-0.4079	-0.3458	-0.2269					
0.875	*****	-0.5270	-0.4771	-0.4089	-0.3058					
0.900	-0.4754	-0.5756	-0.5536	-0.4968	-0.4401					
0.925	*****	-0.6360	-0.6375	-0.5974	-0.9089					
0.950	-0.5475	-0.7019	-0.7424	-0.7147	-0.7425					
0.975	*****	-0.8518	-0.9065	-0.8920	-0.7521					
1.000	-0.7702	-1.3868	-1.7385	-1.9338	-1.1990					
$C_{p,l}$	$C_{p,l}$	$C_{p,l}$	$C_{p,l}$	$C_{p,l}$	$C_{p,l}$	$C_{p,l}$	$C_{p,l}$	$C_{p,l}$	$C_{p,l}$	$C_{p,l}$
-0.200	0.1482	0.1415	0.1643	*****	-0.3483					
-0.400	0.1409	0.1519	0.1398	0.0046	-0.3944					
-0.600	0.1571	0.1523	0.1351	0.0325	-0.4115					
-0.700	0.1787	0.1500	0.1372	0.0462	-0.4235					
-0.800	0.2079	*****	0.1424	0.0717	-0.4230					
-0.850	*****	0.1948	0.1546	0.0809	-0.4589					
-0.900	*****	0.2207	0.1793	0.1085	-0.4794					
-0.950	0.2304	0.2191	0.2020	0.1545	-0.2134					
-0.975	*****	0.1640	0.1640	0.1505	-0.0250					
-1.000	-0.8024	-1.3756	-1.9125	-1.8360	-1.0706					

Medium Radius L.E.
 Run No. = 23 , Point No. = 468
 $C_N = 0.279$, $C_m = -0.0359$
 $\alpha = 8.0^\circ$, $M_\infty = 0.599$
 $R_{mac} = 59.8 \times 10^6$



x/c_R	starb'd C_p	port C_p
0.10	-0.3530	*****
0.20	-0.7702	-0.8024
0.30	-1.1351	*****
0.40	-1.3868	-1.3756
0.50	-1.7228	*****
0.60	-1.7385	-1.9125
0.70	-1.4231	*****
0.80	-1.9338	-1.8360
0.90	*****	*****
0.95	-1.1990	-1.0706

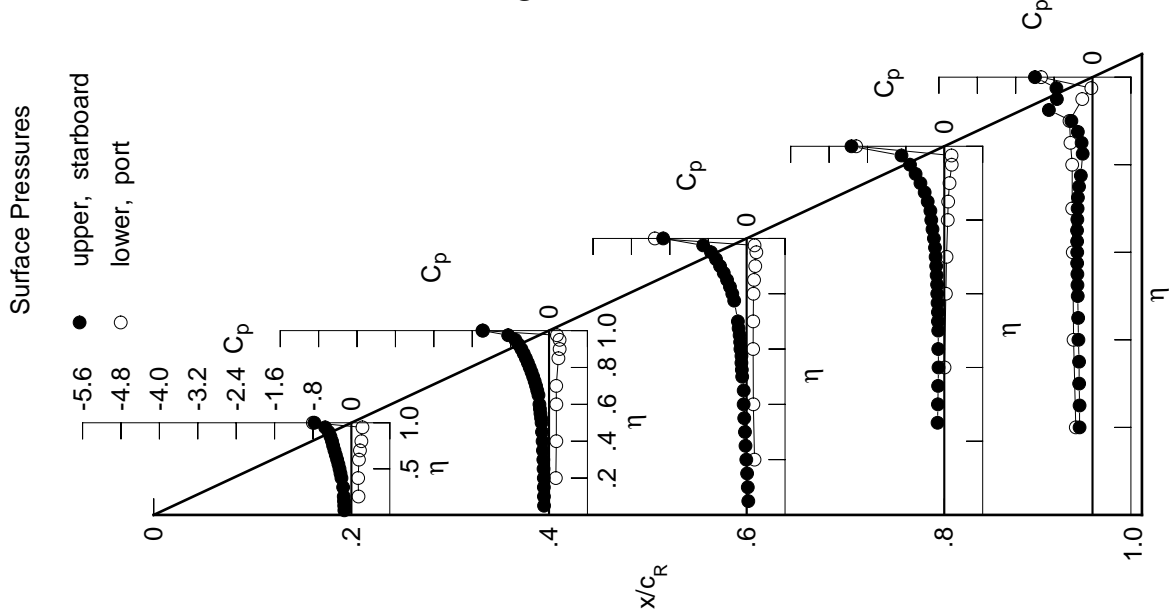

Table D2. Continued.

η	$x/c_R = .2$		$x/c_R = .4$		$x/c_R = .6$		$x/c_R = .8$		$x/c_R = .95$	
	$C_{p,u}$	$C_{p,u}$	$C_{p,u}$	$C_{p,u}$	$C_{p,u}$	$C_{p,u}$	$C_{p,u}$	$C_{p,u}$	$C_{p,u}$	$C_{p,u}$
0.050	-0.1621	-0.1168	0.0231	*****	*****	*****	*****	*****	*****	*****
0.100	-0.1672	-0.1212	0.0120	*****	*****	*****	*****	*****	*****	*****
0.150	-0.1729	-0.1227	-0.0048	*****	*****	*****	*****	*****	*****	*****
0.200	-0.1787	-0.1254	-0.0204	*****	*****	*****	*****	*****	*****	-0.2791
0.250	*****	-0.1307	-0.0377	-0.1516	-0.2739	*****	*****	*****	*****	*****
0.300	-0.1938	-0.1359	-0.0502	-0.1465	-0.2782	*****	*****	*****	*****	*****
0.350	*****	-0.1454	-0.0658	-0.1418	-0.2775	*****	*****	*****	*****	*****
0.400	-0.2301	-0.1540	-0.0793	-0.1358	-0.2868	*****	*****	*****	*****	*****
0.450	-0.2511	-0.1673	-0.0788	-0.1408	-0.2866	*****	*****	*****	*****	*****
0.500	-0.2739	-0.1792	-0.1121	-0.1423	-0.3038	*****	*****	*****	*****	*****
0.525	*****	-0.1898	-0.1202	-0.1476	-0.3190	*****	*****	*****	*****	*****
0.550	-0.3005	-0.2037	-0.1294	-0.1467	-0.3307	*****	*****	*****	*****	*****
0.575	*****	-0.2159	-0.1290	-0.1512	-0.3481	*****	*****	*****	*****	*****
0.600	-0.3296	-0.2275	-0.1530	-0.1556	-0.3603	*****	*****	*****	*****	*****
0.625	*****	*****	-0.1597	-0.1559	-0.3710	*****	*****	*****	*****	*****
0.650	-0.3620	-0.2515	-0.1709	-0.1623	-0.3732	*****	*****	*****	*****	*****
0.675	*****	-0.2769	-0.1962	-0.1811	-0.3670	*****	*****	*****	*****	*****
0.700	-0.3949	-0.3043	-0.2186	-0.2198	-0.4080	*****	*****	*****	*****	*****
0.725	*****	-0.3353	*****	-0.2725	-0.4573	*****	*****	*****	*****	*****
0.750	-0.4294	-0.3703	*****	-0.3197	-0.4948	*****	*****	*****	*****	*****
0.775	*****	-0.4080	-0.3239	-0.3674	-0.5522	*****	*****	*****	*****	*****
0.800	-0.4616	-0.4518	-0.3618	-0.4069	*****	*****	*****	*****	*****	*****
0.825	*****	-0.4979	-0.4035	-0.4152	-0.4967	*****	*****	*****	*****	*****
0.850	-0.5046	-0.5455	-0.4556	-0.4234	-0.4755	*****	*****	*****	*****	*****
0.875	*****	-0.6018	-0.5254	-0.4511	-0.4603	*****	*****	*****	*****	*****
0.900	-0.5585	-0.6625	-0.6111	-0.5104	-0.4480	*****	*****	*****	*****	*****
0.925	*****	-0.7387	-0.7108	-0.6018	-0.5826	*****	*****	*****	*****	*****
0.950	-0.6603	-0.8272	-0.8437	-0.7339	-0.6829	*****	*****	*****	*****	*****
0.975	*****	-1.0218	-1.0495	-0.9754	-0.7969	*****	*****	*****	*****	*****
1.000	-1.0442	-1.8388	-2.0832	-2.3561	-1.6106	*****	*****	*****	*****	*****
-0.200	$C_{p,l}$	$C_{p,l}$	$C_{p,l}$	$C_{p,l}$	$C_{p,l}$	$C_{p,l}$	$C_{p,l}$	$C_{p,l}$	$C_{p,l}$	$C_{p,l}$
-0.400	0.1684	0.1593	0.1792	*****	*****	-0.3444	*****	*****	*****	*****
-0.600	0.1624	0.1695	0.1547	0.0191	-0.3920	*****	*****	*****	*****	*****
-0.700	0.1813	0.1721	0.1524	0.0466	-0.3836	*****	*****	*****	*****	*****
-0.800	0.2022	0.1714	0.1545	0.0620	-0.3837	*****	*****	*****	*****	*****
-0.850	0.2293	*****	0.1619	0.0893	-0.3875	*****	*****	*****	*****	*****
-0.900	*****	0.2155	0.1748	0.1008	-0.4251	*****	*****	*****	*****	*****
-0.950	*****	0.2348	0.1966	0.1288	-0.4410	*****	*****	*****	*****	*****
-0.975	0.2206	0.2149	0.2031	0.1642	-0.1787	*****	*****	*****	*****	*****
-1.000	0.1307	0.1374	0.1361	0.1440	*****	*****	*****	*****	*****	*****
-1.000	-1.0758	-1.7636	-2.2089	-2.2109	-1.4323	*****	*****	*****	*****	*****

Medium Radius L.E.
 Run No. = 23 , Point No. = 469
 $C_N = 0.335$, $C_m = -0.0516$
 $\alpha = 9.0^\circ$, $M_\infty = 0.600$
 $R_{mac} = 59.9 \times 10^6$

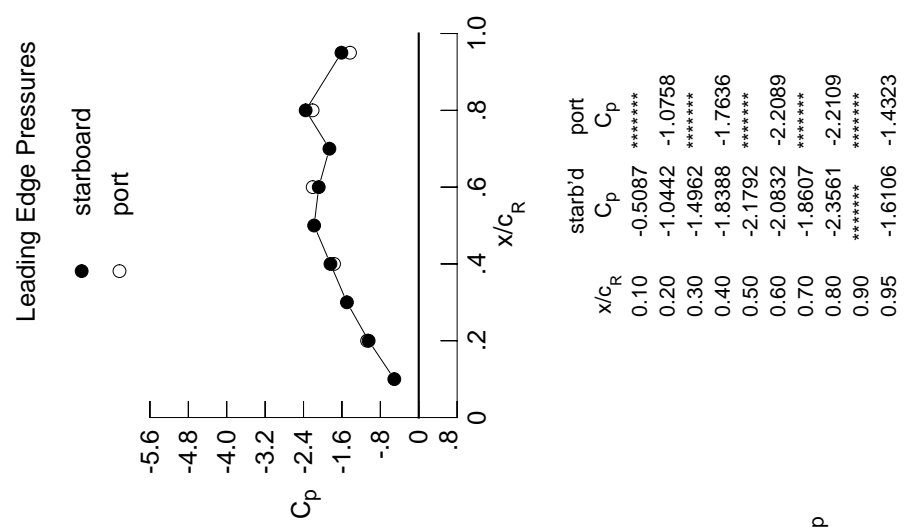

Table D2. Continued.

η	$x/c_R = 0.2$		$x/c_R = 0.4$		$x/c_R = 0.6$		$x/c_R = 0.8$		$x/c_R = 0.95$	
	$C_{p,u}$	$C_{p,u}$	$C_{p,u}$	$C_{p,u}$	$C_{p,u}$	$C_{p,u}$	$C_{p,u}$	$C_{p,u}$	$C_{p,u}$	$C_{p,u}$
0.050	-0.1747	-0.1289	0.0127	*****	*****	*****	*****	*****	*****	*****
0.100	-0.1802	-0.1325	0.0008	*****	*****	*****	*****	*****	*****	*****
0.150	-0.1899	-0.1369	-0.0158	*****	*****	*****	*****	*****	*****	*****
0.200	-0.1966	-0.1385	-0.0329	*****	*****	*****	*****	*****	*****	*****
0.250	*****	-0.1454	-0.0515	-0.1621	-0.2825	*****	*****	*****	*****	*****
0.300	-0.2125	-0.1529	-0.0639	-0.1588	-0.2770	*****	*****	*****	*****	*****
0.350	*****	-0.1626	-0.0830	-0.1531	-0.2708	*****	*****	*****	*****	*****
0.400	-0.2514	-0.1728	-0.0931	-0.1459	-0.2788	*****	*****	*****	*****	*****
0.450	-0.2733	-0.1887	-0.0926	-0.1483	-0.3044	*****	*****	*****	*****	*****
0.500	-0.2988	-0.2021	-0.1263	-0.1420	-0.3428	*****	*****	*****	*****	*****
0.525	*****	-0.2138	-0.1340	-0.1447	-0.3593	*****	*****	*****	*****	*****
0.550	-0.3278	-0.2288	-0.1429	-0.1415	-0.3675	*****	*****	*****	*****	*****
0.575	*****	-0.2422	-0.1421	-0.1482	-0.3803	*****	*****	*****	*****	*****
0.600	-0.3613	-0.2578	-0.1690	-0.1687	-0.3897	*****	*****	*****	*****	*****
0.625	*****	*****	-0.1828	-0.1977	-0.3914	*****	*****	*****	*****	*****
0.650	-0.3986	-0.2917	-0.2243	-0.2432	-0.3932	*****	*****	*****	*****	*****
0.675	*****	-0.3197	-0.2843	-0.2938	-0.4055	*****	*****	*****	*****	*****
0.700	-0.4371	-0.3462	-0.3209	-0.3416	-0.4502	*****	*****	*****	*****	*****
0.725	*****	-0.3781	*****	-0.3662	-0.4922	*****	*****	*****	*****	*****
0.750	-0.4791	-0.4125	*****	-0.3810	-0.4901	*****	*****	*****	*****	*****
0.775	*****	-0.4540	-0.4170	-0.4256	-0.4862	*****	*****	*****	*****	*****
0.800	-0.5212	-0.5014	-0.4160	-0.4899	*****	*****	*****	*****	*****	*****
0.825	*****	-0.5518	-0.4512	-0.5480	-0.5936	*****	*****	*****	*****	*****
0.850	-0.5763	-0.6066	-0.4960	-0.5676	-0.6700	*****	*****	*****	*****	*****
0.875	*****	-0.6721	-0.5510	-0.4991	-0.6702	*****	*****	*****	*****	*****
0.900	-0.6481	-0.7446	-0.6443	-0.5190	-0.5598	*****	*****	*****	*****	*****
0.925	*****	-0.8368	-0.8003	-0.7070	-0.4923	*****	*****	*****	*****	*****
0.950	-0.7849	-0.9488	-0.8589	-0.9033	-0.4515	*****	*****	*****	*****	*****
0.975	*****	-1.1806	-1.3660	-0.9456	-0.4448	*****	*****	*****	*****	*****
1.000	-1.3715	-2.2672	-2.2455	-2.4627	-1.4446	*****	*****	*****	*****	*****
-0.200	$C_{p,l}$	0.1817	0.1979	*****	-0.3382	$C_{p,l}$	0.1817	0.1979	*****	-0.3382
-0.400	0.1893	0.1938	0.1744	0.0345	-0.3898	0.1893	0.1938	0.1744	0.0345	-0.3898
-0.600	0.2091	0.1961	0.1733	0.0628	-0.3706	0.2091	0.1961	0.1733	0.0628	-0.3706
-0.700	0.2294	0.1971	0.1760	0.0809	-0.3907	0.2294	0.1971	0.1760	0.0809	-0.3907
-0.800	0.2529	*****	0.1854	0.1085	-0.4051	0.2529	*****	0.1854	0.1085	-0.4051
-0.850	*****	0.2385	0.1979	0.1203	-0.4378	*****	0.2385	0.1979	0.1203	-0.4378
-0.900	*****	0.2513	0.2160	0.1479	-0.4397	*****	0.2513	0.2160	0.1479	-0.4397
-0.950	0.2073	0.2100	0.2058	0.1741	-0.1637	0.2073	0.2100	0.2058	0.1741	-0.1637
-0.975	*****	0.0940	0.1152	0.1288	-0.0016	*****	0.0940	0.1152	0.1288	-0.0016
-1.000	-1.4188	-2.1663	-2.4055	-2.3287	-1.4269	-1.4188	-2.1663	-2.4055	-2.3287	-1.4269

Medium Radius L.E.

Run No. = 23, Point No. = 470

$C_N = 0.380$, $C_m = -0.0573$

$\alpha = 10.1^\circ$, $M_\infty = 0.599$

$R_{mac} = 59.8 \times 10^6$

Leading Edge Pressures

● starboard
○ port

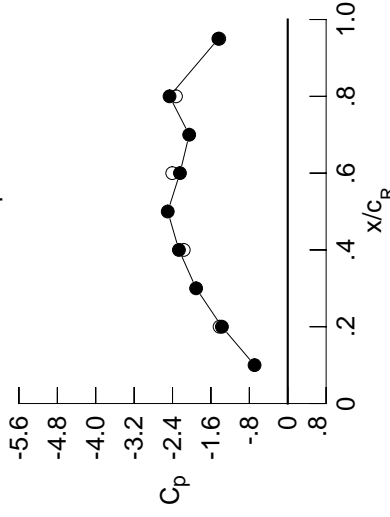

x/c_R	starb'd C_p	port C_p
0.10	-0.6910	*****
0.20	-1.3715	-1.4188
0.30	-1.9087	*****
0.40	-2.2672	-2.1663
0.50	-2.4998	*****
0.60	-2.2455	-2.4055
0.70	-2.0527	*****
0.80	-2.4627	-2.3287
0.90	*****	*****
0.95	-1.4446	-1.4269

Surface Pressures

● upper, starboard
○ lower, port

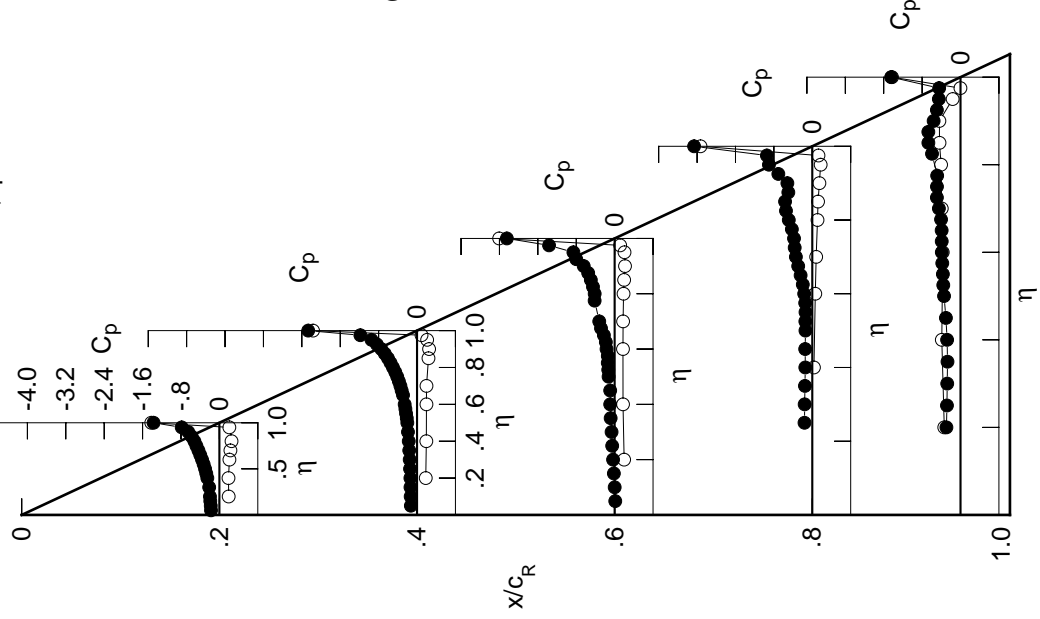
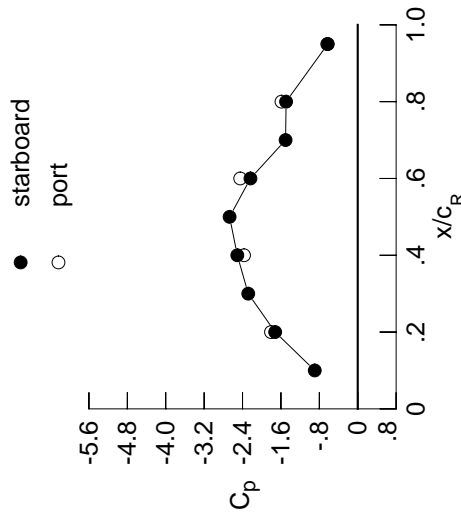

Table D2. Continued.

η	x/c_R .2	x/c_R .4	x/c_R .6	x/c_R .8	x/c_R .95
	$C_{p,u}$	$C_{p,u}$	$C_{p,u}$	$C_{p,u}$	$C_{p,u}$
0.050	-0.1915	-0.1521	-0.0087	*****	*****
0.100	-0.1971	-0.1522	-0.0200	*****	*****
0.150	-0.2101	-0.1598	-0.0388	*****	*****
0.200	-0.2192	-0.1619	-0.0556	*****	-0.3152
0.250	*****	-0.1716	-0.0774	-0.1812	-0.2951
0.300	-0.2377	-0.1787	-0.0907	-0.1765	-0.2635
0.350	*****	-0.1906	-0.1063	-0.1677	-0.2649
0.400	-0.2765	-0.2018	-0.1163	-0.1515	-0.3181
0.450	-0.3006	-0.2148	-0.1070	-0.1524	-0.3526
0.500	-0.3279	-0.2329	-0.1367	-0.1444	-0.3725
0.525	*****	-0.2475	-0.1530	-0.1553	-0.3814
0.550	-0.3598	-0.2722	-0.1829	-0.1707	-0.3788
0.575	*****	-0.2947	-0.2009	-0.2067	-0.3728
0.600	-0.3972	-0.3187	-0.2613	-0.2438	-0.3509
0.625	*****	*****	-0.2977	-0.2619	-0.3305
0.650	-0.4392	-0.3737	-0.3563	-0.2689	-0.3194
0.675	*****	-0.4074	-0.4149	-0.2632	-0.3134
0.700	-0.4836	-0.4282	-0.4357	-0.2490	-0.3219
0.725	*****	-0.4490	*****	-0.2443	-0.3687
0.750	-0.5340	-0.4704	*****	-0.2660	-0.5106
0.775	*****	-0.5033	-0.5243	-0.4109	-0.7629
0.800	-0.5849	-0.5461	-0.5177	-0.7433	*****
0.825	*****	-0.5994	-0.5170	-1.1072	-0.9740
0.850	-0.6543	-0.6548	-0.5771	-1.2154	-0.8626
0.875	*****	-0.7329	-0.7115	-1.1167	-0.6309
0.900	-0.7450	-0.8184	-0.8551	-0.9516	-0.5357
0.925	*****	-0.9509	-1.1054	-0.8410	-0.5144
0.950	-0.9196	-1.0681	-1.3232	-0.7745	-0.4123
0.975	*****	-1.4201	-1.3530	-0.7226	-0.3575
1.000	-1.7200	-2.5087	-2.2350	-1.4925	-0.6242
	$C_{p,l}$	$C_{p,l}$	$C_{p,l}$	$C_{p,l}$	$C_{p,l}$
-0.200	0.2188	0.2040	0.2146	*****	-0.3360
-0.400	0.2147	0.2150	0.1942	0.0486	-0.3865
-0.600	0.2359	0.2200	0.1934	0.0768	-0.3896
-0.700	0.2544	0.2221	0.1979	0.0971	-0.4166
-0.800	0.2730	*****	0.2082	0.1239	-0.4190
-0.850	*****	0.2600	0.2204	0.1388	-0.4466
-0.900	*****	0.2641	0.2356	0.1657	-0.4442
-0.950	0.1863	0.2026	0.2110	0.1882	-0.1663
-0.975	*****	0.0570	0.1026	0.1432	-0.0021
-1.000	-1.8069	-2.3692	-2.4484	-1.5889	-0.6341

Medium Radius L.E.
 Run No. = 23, Point No. = 471
 $C_N = 0.445$, $C_m = -0.0707$
 $\alpha = 11.1^\circ$, $M_\infty = 0.599$
 $R_{mac} = 59.8 \times 10^6$

Leading Edge Pressures



x/c_R	starb'd C_p	port C_p
0.10	-0.8951	*****
0.20	-1.7200	-1.8069
0.30	-2.2810	*****
0.40	-2.5087	-2.3692
0.50	-2.6694	*****
0.60	-2.2350	-2.4484
0.70	-1.5029	*****
0.80	-1.4925	-1.5889
0.90	*****	*****
0.95	-0.6242	-0.6341

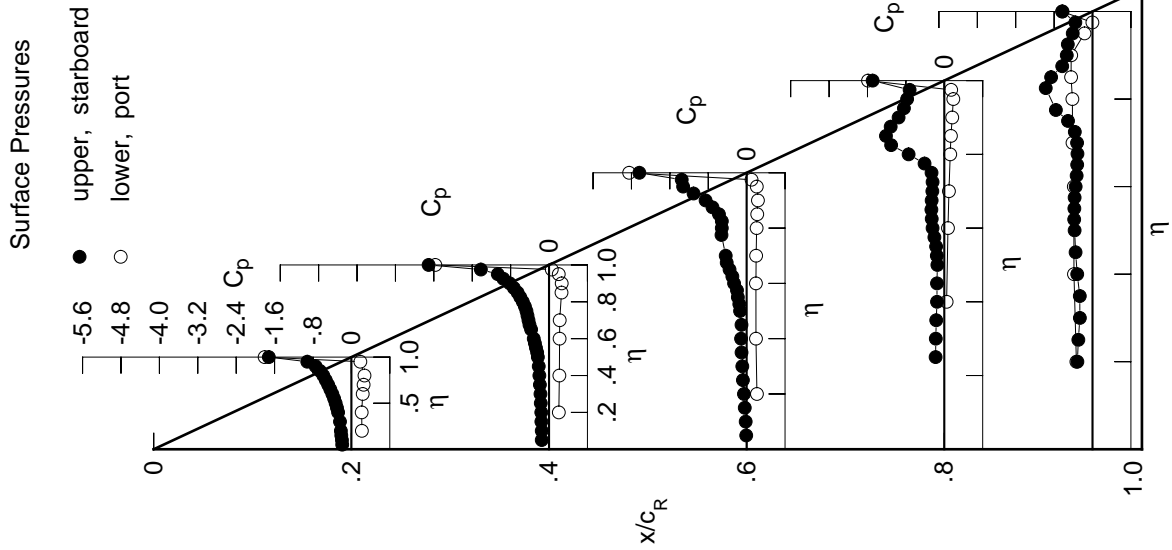

Table D2. Continued.

η	$x/c_R = .2$		$x/c_R = .4$		$x/c_R = .6$		$x/c_R = .8$		$x/c_R = .95$	
	$C_{p,u}$	$C_{p,u}$	$C_{p,u}$	$C_{p,u}$	$C_{p,u}$	$C_{p,u}$	$C_{p,u}$	$C_{p,u}$	$C_{p,u}$	$C_{p,u}$
0.050	-0.2080	-0.1780	-0.0279	*****	*****	*****	*****	*****	*****	*****
0.100	-0.2099	-0.1781	-0.0377	*****	*****	*****	*****	*****	*****	*****
0.150	-0.2277	-0.1846	-0.0566	*****	*****	*****	*****	*****	*****	*****
0.200	-0.2405	-0.1862	-0.0747	*****	*****	*****	*****	*****	*****	*****
0.250	*****	-0.1989	-0.0991	-0.1915	-0.1915	-0.1915	-0.1915	-0.1915	-0.1915	-0.1915
0.300	-0.2644	-0.2092	-0.1076	-0.1797	-0.1797	-0.1797	-0.1797	-0.1797	-0.1797	-0.1797
0.350	*****	-0.2209	-0.1171	-0.1681	-0.1681	-0.1681	-0.1681	-0.1681	-0.1681	-0.1681
0.400	-0.3038	-0.2238	-0.1254	-0.1548	-0.1548	-0.1548	-0.1548	-0.1548	-0.1548	-0.1548
0.450	-0.3280	-0.2414	-0.1253	-0.1696	-0.1696	-0.1696	-0.1696	-0.1696	-0.1696	-0.1696
0.500	-0.3570	-0.2824	-0.2023	-0.1805	-0.1805	-0.1805	-0.1805	-0.1805	-0.1805	-0.1805
0.525	*****	-0.3232	-0.2338	-0.1906	-0.1906	-0.1906	-0.1906	-0.1906	-0.1906	-0.1906
0.550	-0.3923	-0.3631	-0.2599	-0.1917	-0.1917	-0.1917	-0.1917	-0.1917	-0.1917	-0.1917
0.575	*****	-0.3871	-0.2743	-0.1917	-0.1917	-0.1917	-0.1917	-0.1917	-0.1917	-0.1917
0.600	-0.4328	-0.3950	-0.3258	-0.1888	-0.1888	-0.1888	-0.1888	-0.1888	-0.1888	-0.1888
0.625	*****	*****	-0.3492	-0.1804	-0.1804	-0.1804	-0.1804	-0.1804	-0.1804	-0.1804
0.650	-0.4804	-0.4279	-0.3833	-0.1829	-0.1829	-0.1829	-0.1829	-0.1829	-0.1829	-0.1829
0.675	*****	-0.4623	-0.4243	-0.2006	-0.4238	-0.4238	-0.4238	-0.4238	-0.4238	-0.4238
0.700	-0.5325	-0.4933	-0.4539	-0.2550	-0.5545	-0.5545	-0.5545	-0.5545	-0.5545	-0.5545
0.725	*****	-0.5248	*****	-0.4171	-0.7401	-0.7401	-0.7401	-0.7401	-0.7401	-0.7401
0.750	-0.5913	-0.5497	*****	-0.7191	-0.8895	-0.8895	-0.8895	-0.8895	-0.8895	-0.8895
0.775	*****	-0.5657	-0.7168	-1.1008	-0.9580	-0.9580	-0.9580	-0.9580	-0.9580	-0.9580
0.800	-0.6527	-0.6089	-0.8547	-1.2752	*****	*****	*****	*****	*****	*****
0.825	*****	-0.6346	-0.9802	-1.2642	-0.7028	-0.7028	-0.7028	-0.7028	-0.7028	-0.7028
0.850	-0.7374	-0.6689	-1.0930	-0.9838	-0.5388	-0.5388	-0.5388	-0.5388	-0.5388	-0.5388
0.875	*****	-0.8248	-1.2008	-0.7577	-0.4901	-0.4901	-0.4901	-0.4901	-0.4901	-0.4901
0.900	-0.8446	-0.9327	-1.2419	-0.7308	-0.4685	-0.4685	-0.4685	-0.4685	-0.4685	-0.4685
0.925	*****	-0.9621	-1.1979	-0.7013	-0.4578	-0.4578	-0.4578	-0.4578	-0.4578	-0.4578
0.950	-1.0524	-1.3311	-1.1128	-0.8091	-0.3747	-0.3747	-0.3747	-0.3747	-0.3747	-0.3747
0.975	*****	-1.7529	-1.0485	-0.7168	-0.3213	-0.3213	-0.3213	-0.3213	-0.3213	-0.3213
1.000	-2.0364	-2.6443	-2.0098	-1.3746	-0.5468	-0.5468	-0.5468	-0.5468	-0.5468	-0.5468
-0.200	$C_{p,l}$	$C_{p,l}$	$C_{p,l}$	$C_{p,l}$	$C_{p,l}$	$C_{p,l}$	$C_{p,l}$	$C_{p,l}$	$C_{p,l}$	$C_{p,l}$
-0.400	0.2468	0.2296	0.2357	*****	-0.3290	-0.3290	-0.3290	-0.3290	-0.3290	-0.3290
-0.600	0.2433	0.2404	0.2152	0.0646	-0.3715	-0.3715	-0.3715	-0.3715	-0.3715	-0.3715
-0.800	0.2642	0.2469	0.2162	0.0941	-0.3962	-0.3962	-0.3962	-0.3962	-0.3962	-0.3962
-1.000	0.2816	0.2488	0.2213	0.1135	-0.4162	-0.4162	-0.4162	-0.4162	-0.4162	-0.4162
-1.200	0.2936	*****	0.2307	0.1419	-0.4139	-0.4139	-0.4139	-0.4139	-0.4139	-0.4139
-1.400	*****	0.2810	0.2429	0.1544	-0.4396	-0.4396	-0.4396	-0.4396	-0.4396	-0.4396
-1.600	*****	0.2769	0.2539	0.1803	-0.4303	-0.4303	-0.4303	-0.4303	-0.4303	-0.4303
-1.800	0.1635	0.1953	0.2187	0.1955	-0.1531	-0.1531	-0.1531	-0.1531	-0.1531	-0.1531
-2.000	*****	0.0241	0.1006	0.1424	0.0016	0.0016	0.0016	0.0016	0.0016	0.0016
-2.200	-2.1887	-2.4530	-2.2362	-1.2507	-0.6176	-0.6176	-0.6176	-0.6176	-0.6176	-0.6176

Medium Radius L.E.
 Run No. = 23 , Point No. = 472
 $C_N = 0.504$, $C_m = -0.0803$
 $\alpha = 12.1^\circ$, $M_\infty = 0.598$
 $R_{mac} = 59.7 \times 10^6$

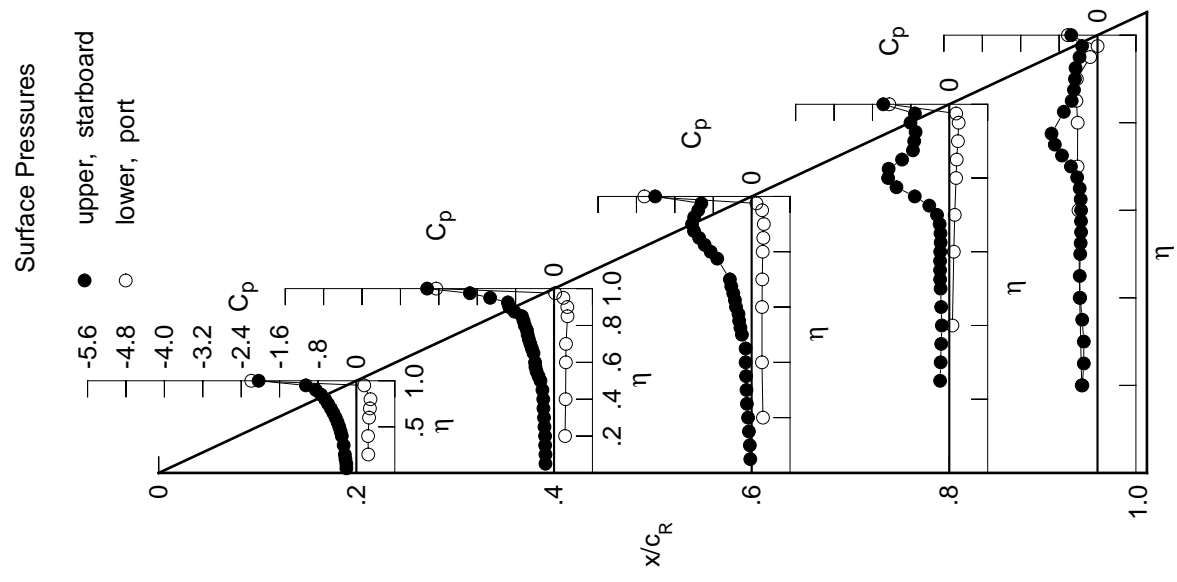
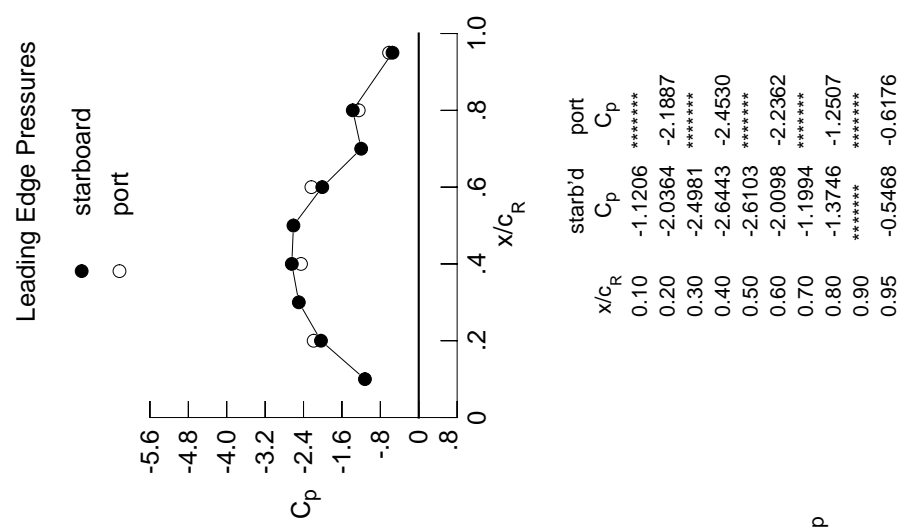
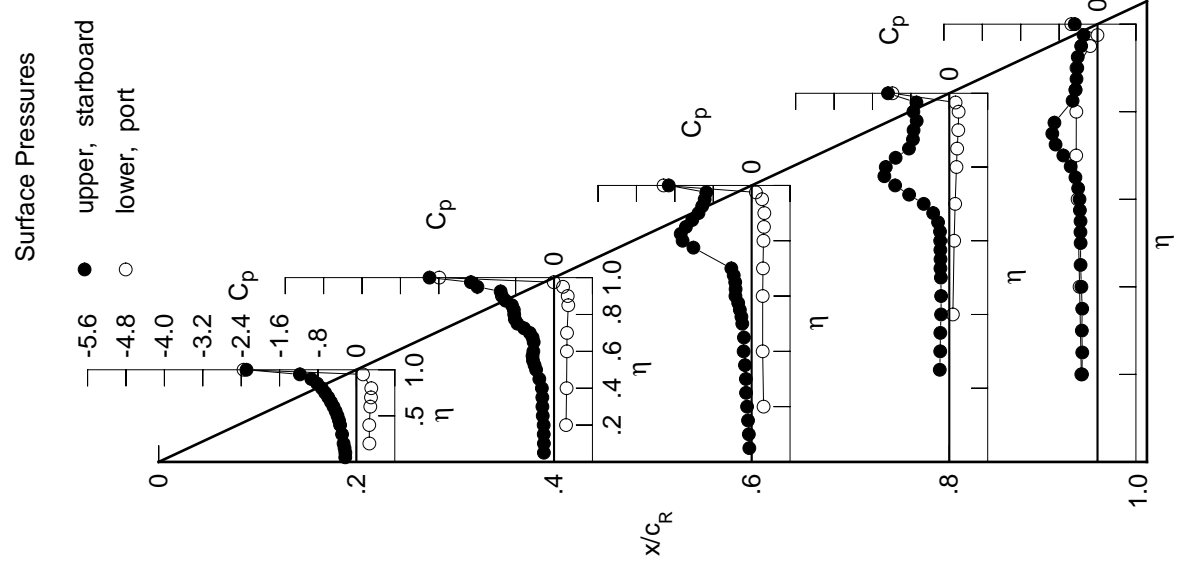
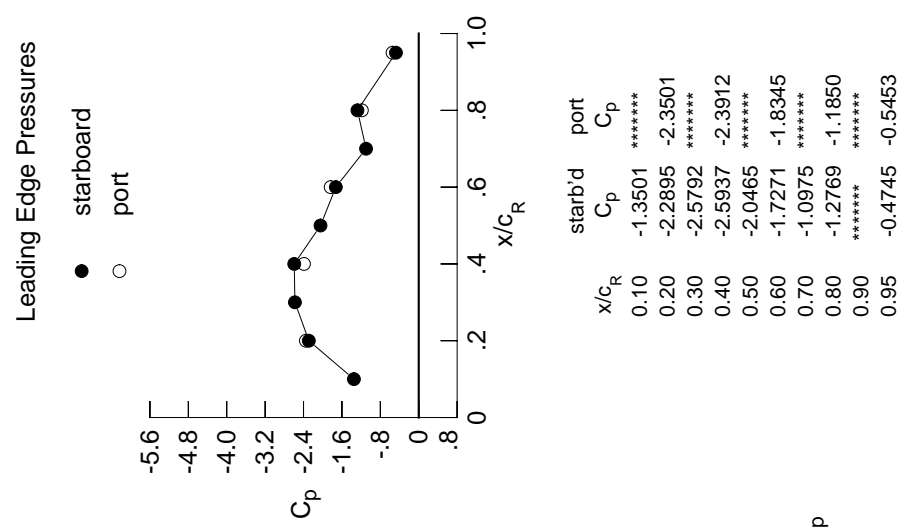

Table D2. Continued.

η	$x/c_R = .2$		$x/c_R = .4$		$x/c_R = .6$		$x/c_R = .8$		$x/c_R = .95$	
	$C_{p,u}$	$C_{p,u}$	$C_{p,u}$	$C_{p,u}$	$C_{p,u}$	$C_{p,u}$	$C_{p,u}$	$C_{p,u}$	$C_{p,u}$	$C_{p,u}$
0.050	-0.2319	-0.2108	-0.0480	*****	*****	*****	*****	*****	*****	*****
0.100	-0.2301	-0.2110	-0.0583	*****	*****	*****	*****	*****	*****	*****
0.150	-0.2467	-0.2146	-0.0755	*****	*****	*****	*****	*****	*****	*****
0.200	-0.2671	-0.2158	-0.0952	*****	*****	*****	*****	*****	*****	*****
0.250	*****	-0.2349	-0.1168	-0.1981	-0.1888	-0.3261	*****	*****	*****	*****
0.300	-0.2984	-0.2423	-0.1198	-0.1888	-0.1888	-0.3261	*****	*****	*****	*****
0.350	*****	-0.2440	-0.1389	-0.1862	-0.3194	*****	*****	*****	*****	*****
0.400	-0.3391	-0.2532	-0.1674	-0.1712	-0.3359	*****	*****	*****	*****	*****
0.450	-0.3627	-0.3063	-0.1607	-0.1708	-0.3526	*****	*****	*****	*****	*****
0.500	-0.3934	-0.3739	-0.1955	-0.1753	-0.3520	*****	*****	*****	*****	*****
0.525	*****	-0.4058	-0.2137	-0.1847	-0.3551	*****	*****	*****	*****	*****
0.550	-0.4320	-0.4380	-0.2458	-0.1827	-0.3535	*****	*****	*****	*****	*****
0.575	*****	-0.4477	-0.2802	-0.1857	-0.3671	*****	*****	*****	*****	*****
0.600	-0.4778	-0.4313	-0.3377	-0.1897	-0.3756	*****	*****	*****	*****	*****
0.625	*****	*****	-0.3343	-0.1940	-0.4031	*****	*****	*****	*****	*****
0.650	-0.5306	-0.4241	-0.3423	-0.2337	-0.4600	*****	*****	*****	*****	*****
0.675	*****	-0.4469	-0.3738	-0.3358	-0.5589	*****	*****	*****	*****	*****
0.700	-0.5866	-0.5056	-0.4234	-0.5326	-0.7119	*****	*****	*****	*****	*****
0.725	*****	-0.6243	*****	-0.8365	-0.8736	*****	*****	*****	*****	*****
0.750	-0.6515	-0.7623	*****	-1.1280	-0.9418	*****	*****	*****	*****	*****
0.775	*****	-0.8172	-1.2128	-1.3525	-0.8973	*****	*****	*****	*****	*****
0.800	-0.7205	-0.8297	-1.4388	-1.3230	*****	*****	*****	*****	*****	*****
0.825	*****	-0.8378	-1.4773	-1.1180	-0.5192	*****	*****	*****	*****	*****
0.850	-0.8166	-0.8779	-1.3692	-0.8409	-0.4585	*****	*****	*****	*****	*****
0.875	*****	-1.0095	-1.2375	-0.7572	-0.4376	*****	*****	*****	*****	*****
0.900	-0.9392	-1.0858	-1.1070	-0.7441	-0.4215	*****	*****	*****	*****	*****
0.925	*****	-1.1130	-1.0301	-0.6789	-0.4118	*****	*****	*****	*****	*****
0.950	-1.1772	-1.5958	-0.9785	-0.7483	-0.3404	*****	*****	*****	*****	*****
0.975	*****	-1.7317	-0.9457	-0.6841	-0.2893	*****	*****	*****	*****	*****
1.000	-2.2895	-2.5937	-1.7271	-1.2769	-0.4745	*****	*****	*****	*****	*****
-0.200	$C_{p,l}$	$C_{p,l}$	$C_{p,l}$	$C_{p,l}$	$C_{p,l}$	$C_{p,l}$	$C_{p,l}$	$C_{p,l}$	$C_{p,l}$	$C_{p,l}$
-0.400	0.2706	0.2504	0.2489	*****	-0.3377	*****	*****	*****	*****	*****
-0.600	0.2681	0.2610	0.2295	0.0745	-0.3733	*****	*****	*****	*****	*****
-0.700	0.2894	0.2681	0.2303	0.1012	-0.4148	*****	*****	*****	*****	*****
-0.800	0.3041	0.2706	0.2362	0.1221	-0.4441	*****	*****	*****	*****	*****
-0.850	0.3102	*****	0.2461	0.1493	-0.4419	*****	*****	*****	*****	*****
-0.900	*****	0.2972	0.2571	0.1639	-0.4592	*****	*****	*****	*****	*****
-0.950	0.1378	0.1869	0.2177	0.1945	-0.4382	*****	*****	*****	*****	*****
-0.975	*****	-0.0055	0.0890	0.1302	-0.0016	*****	*****	*****	*****	*****
-1.000	-2.3501	-2.3912	-1.8345	-1.1850	-0.5453	*****	*****	*****	*****	*****

Medium Radius L.E.
 Run No. = 23, Point No. = 473
 $C_N = 0.557$, $C_m = -0.0849$
 $\alpha = 13.2^\circ$, $M_\infty = 0.599$
 $R_{mac} = 59.8 \times 10^6$



x/c_R	starb'd C_p	port C_p
0.10	-1.3501	*****
0.20	-2.2895	-2.3501
0.30	-2.5792	*****
0.40	-2.5937	-2.3912
0.50	-2.0465	*****
0.60	-1.7271	-1.8345
0.70	-1.0975	*****
0.80	-1.2769	-1.1850
0.90	*****	*****
0.95	-0.4745	-0.5453

Table D2. Continued.

η	$x/c_R = .2$		$x/c_R = .4$		$x/c_R = .6$		$x/c_R = .8$		$x/c_R = .95$	
	$C_{p,u}$	$C_{p,u}$	$C_{p,u}$	$C_{p,u}$	$C_{p,u}$	$C_{p,u}$	$C_{p,u}$	$C_{p,u}$	$C_{p,u}$	$C_{p,u}$
0.050	-0.2575	-0.2427	-0.0605	*****	*****	*****	*****	*****	*****	*****
0.100	-0.2526	-0.2435	-0.0718	*****	*****	*****	*****	*****	*****	*****
0.150	-0.2674	-0.2462	-0.0867	*****	*****	*****	*****	*****	*****	*****
0.200	-0.2915	-0.2448	-0.1070	*****	*****	*****	*****	*****	*****	*****
0.250	*****	-0.2624	-0.1228	-0.1997	-0.3185	*****	*****	*****	*****	*****
0.300	-0.3390	-0.2643	-0.1282	-0.1885	-0.3468	*****	*****	*****	*****	*****
0.350	*****	-0.2686	-0.1576	-0.1934	-0.3486	*****	*****	*****	*****	*****
0.400	-0.3798	-0.2998	-0.1967	-0.1888	-0.3506	*****	*****	*****	*****	*****
0.450	-0.4083	-0.3711	-0.1992	-0.1859	-0.3486	*****	*****	*****	*****	*****
0.500	-0.4468	-0.4297	-0.2210	-0.1806	-0.3678	*****	*****	*****	*****	*****
0.525	*****	-0.4585	-0.2191	-0.1808	-0.3901	*****	*****	*****	*****	*****
0.550	-0.4900	-0.4887	-0.2162	-0.1789	-0.4036	*****	*****	*****	*****	*****
0.575	*****	-0.5109	-0.2087	-0.1887	-0.4441	*****	*****	*****	*****	*****
0.600	-0.5327	-0.5218	-0.2258	-0.2114	-0.4808	*****	*****	*****	*****	*****
0.625	*****	*****	-0.2163	-0.2549	-0.5467	*****	*****	*****	*****	*****
0.650	-0.5821	-0.5129	-0.2469	-0.3531	-0.6189	*****	*****	*****	*****	*****
0.675	*****	-0.5200	-0.3586	-0.5272	-0.6741	*****	*****	*****	*****	*****
0.700	-0.6372	-0.5494	-0.5678	-0.7672	-0.7241	*****	*****	*****	*****	*****
0.725	*****	-0.6321	*****	-1.0250	-0.7505	*****	*****	*****	*****	*****
0.750	-0.7047	-0.8373	*****	-1.1634	-0.7225	*****	*****	*****	*****	*****
0.775	*****	-1.0669	-1.6692	-1.1209	-0.6536	*****	*****	*****	*****	*****
0.800	-0.7763	-1.1961	-1.7543	-0.8497	*****	*****	*****	*****	*****	*****
0.825	*****	-1.2489	-1.6963	-0.7050	-0.4830	*****	*****	*****	*****	*****
0.850	-0.8942	-1.2789	-1.4797	-0.7042	-0.4563	*****	*****	*****	*****	*****
0.875	*****	-1.3342	-1.1870	-0.7060	-0.4431	*****	*****	*****	*****	*****
0.900	-1.1091	-1.3952	-1.0511	-0.6977	-0.4242	*****	*****	*****	*****	*****
0.925	*****	-1.4694	-1.0002	-0.7028	-0.4079	*****	*****	*****	*****	*****
0.950	-1.5822	-1.5491	-0.9060	-0.7446	-0.3357	*****	*****	*****	*****	*****
0.975	*****	-1.4525	-0.8465	-0.6891	-0.2900	*****	*****	*****	*****	*****
1.000	-2.4629	-2.1967	-1.4120	-1.1825	-0.4817	*****	*****	*****	*****	*****
	$C_{p,l}$	$C_{p,l}$	$C_{p,l}$	$C_{p,l}$	$C_{p,l}$	$C_{p,l}$	$C_{p,l}$	$C_{p,l}$	$C_{p,l}$	$C_{p,l}$
-0.200	0.3003	0.2750	0.2685	*****	*****	*****	*****	*****	*****	*****
-0.400	0.2977	0.2857	0.2497	0.0867	0.3758	*****	*****	*****	*****	*****
-0.600	0.3186	0.2930	0.2496	0.1175	-0.4176	*****	*****	*****	*****	*****
-0.700	0.3302	0.2959	0.2562	0.1361	-0.4553	*****	*****	*****	*****	*****
-0.800	0.3300	*****	0.2650	0.1639	-0.4503	*****	*****	*****	*****	*****
-0.850	*****	0.3163	0.2739	0.1775	-0.4610	*****	*****	*****	*****	*****
-0.900	*****	0.2974	0.2758	0.1987	-0.4297	*****	*****	*****	*****	*****
-0.950	0.1164	0.1841	0.2172	0.1964	-0.1391	*****	*****	*****	*****	*****
-0.975	*****	-0.0230	0.0766	0.1196	0.0045	*****	*****	*****	*****	*****
-1.000	-2.4600	-2.0750	-1.5884	-1.1633	-0.5093	*****	*****	*****	*****	*****

Medium Radius L.E.
 Run No. = 23 , Point No. = 474
 $C_N = 0.599$, $C_m = -0.0851$
 $\alpha = 14.2^\circ$, $M_\infty = 0.599$
 $R_{mac} = 59.8 \times 10^6$

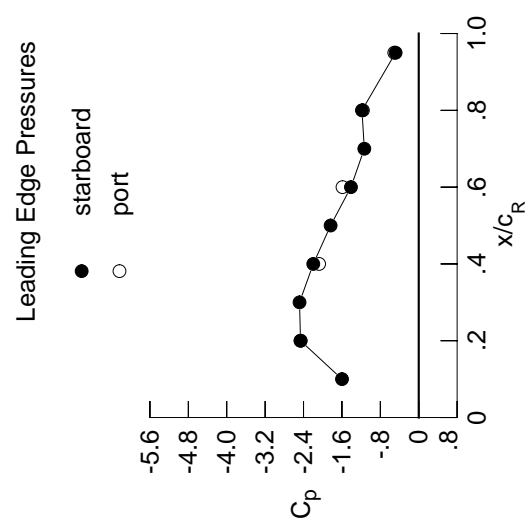

x/c_R	starb'd C_p	port C_p
0.10	-1.5982	*****
0.20	-2.4629	-2.4600
0.30	-2.4834	*****
0.40	-2.1967	-2.0750
0.50	-1.8363	*****
0.60	-1.4120	-1.5884
0.70	-1.1339	*****
0.80	-1.1825	-1.1633
0.90	*****	*****
0.95	-0.4817	-0.5093

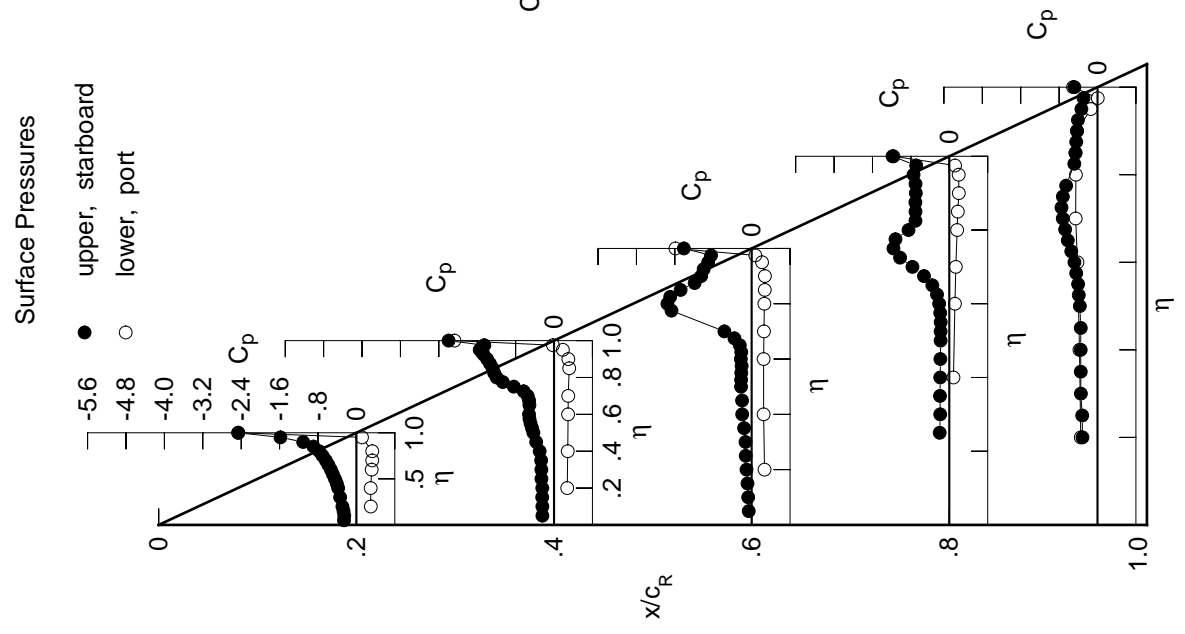
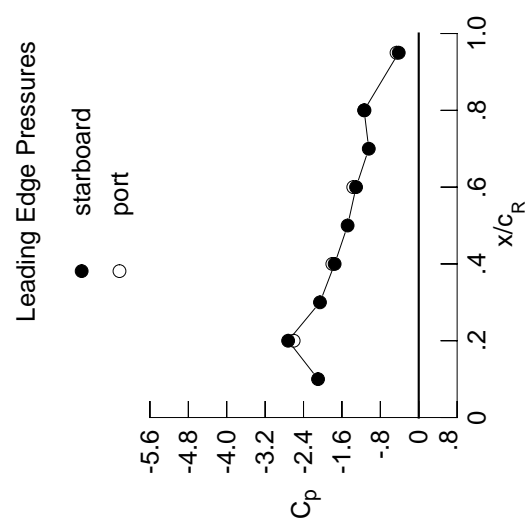

Table D2. Continued.

η	x/c_R .2	x/c_R .4	x/c_R .6	x/c_R .8	x/c_R .95
	$C_{p,u}$	$C_{p,u}$	$C_{p,u}$	$C_{p,u}$	$C_{p,u}$
0.050	-0.3345	-0.3138	-0.1029	*****	*****
0.100	-0.3250	-0.3135	-0.1138	*****	*****
0.150	-0.3371	-0.3153	-0.1317	*****	*****
0.200	-0.3559	-0.3082	-0.1447	*****	-0.2883
0.250	*****	-0.3180	-0.1707	-0.2267	-0.3062
0.300	-0.4160	-0.3416	-0.1866	-0.2205	-0.3140
0.350	*****	-0.3743	-0.2018	-0.2120	-0.3130
0.400	-0.5362	-0.3870	-0.2081	-0.1982	-0.3404
0.450	-0.5525	-0.3932	-0.1936	-0.1973	-0.3726
0.500	-0.5481	-0.4176	-0.2370	-0.2084	-0.4114
0.525	*****	-0.4655	-0.2576	-0.2328	-0.4484
0.550	-0.5899	-0.5274	-0.2927	-0.2709	-0.4887
0.575	*****	-0.5878	-0.3436	-0.3428	-0.5706
0.600	-0.6296	-0.6515	-0.5010	-0.4556	-0.6683
0.625	*****	*****	-0.6521	-0.6167	-0.7987
0.650	-0.6838	-0.8466	-0.9316	-0.8378	-0.9232
0.675	*****	-1.0323	-1.2518	-1.1021	-0.9856
0.700	-0.7678	-1.2688	-1.4951	-1.3439	-0.9827
0.725	*****	-1.4938	*****	-1.4727	-0.8664
0.750	-0.8570	-1.6765	*****	-1.3380	-0.6220
0.775	*****	-1.7273	-1.8231	-1.0476	-0.4357
0.800	-0.8568	-1.6978	-1.6438	-0.8195	*****
0.825	*****	-1.6240	-1.3821	-0.7799	-0.4094
0.850	-1.4944	-1.5496	-1.1759	-0.7853	-0.3863
0.875	*****	-1.4943	-1.1144	-0.7771	-0.3822
0.900	-1.9169	-1.4585	-1.0741	-0.7619	-0.3772
0.925	*****	-1.4181	-0.9946	-0.7457	-0.3655
0.950	-1.8597	-1.3590	-0.9076	-0.7628	-0.3004
0.975	*****	-1.2905	-0.8680	-0.7276	-0.2611
1.000	-2.7204	-1.7518	-1.3053	-1.1377	-0.4170
	$C_{p,l}$	$C_{p,l}$	$C_{p,l}$	$C_{p,l}$	$C_{p,l}$
-0.200	0.3558	0.3219	0.3028	*****	-0.3480
-0.400	0.3553	0.3326	0.2844	0.1149	-0.3901
-0.600	0.3720	0.3376	0.2862	0.1443	-0.4528
-0.700	0.3780	0.3390	0.2906	0.1636	-0.4953
-0.800	0.3620	*****	0.2964	0.1904	-0.4691
-0.850	*****	0.3433	0.2999	0.2019	-0.4649
-0.900	*****	0.3078	0.2893	0.2184	-0.4168
-0.950	0.0672	0.1632	0.2000	0.1931	-0.1222
-0.975	*****	-0.0749	0.0282	0.0868	0.0042
-1.000	-2.6054	-1.7998	-1.3641	-1.1298	-0.4620

Medium Radius L.E.
 Run No. = 23 , Point No. = 475
 $C_N = 0.728$, $C_m = -0.1015$
 $\alpha = 16.4^\circ$, $M_\infty = 0.599$
 $R_{mac} = 59.8 \times 10^6$



x/c_R	starb'd C_p	port C_p
0.10	-2.0975	*****
0.20	-2.7204	-2.6054
0.30	-2.0579	*****
0.40	-1.7518	-1.7998
0.50	-1.4819	*****
0.60	-1.3053	-1.3641
0.70	-1.0405	*****
0.80	-1.1377	-1.1298
0.90	*****	*****
0.95	-0.4170	-0.4620

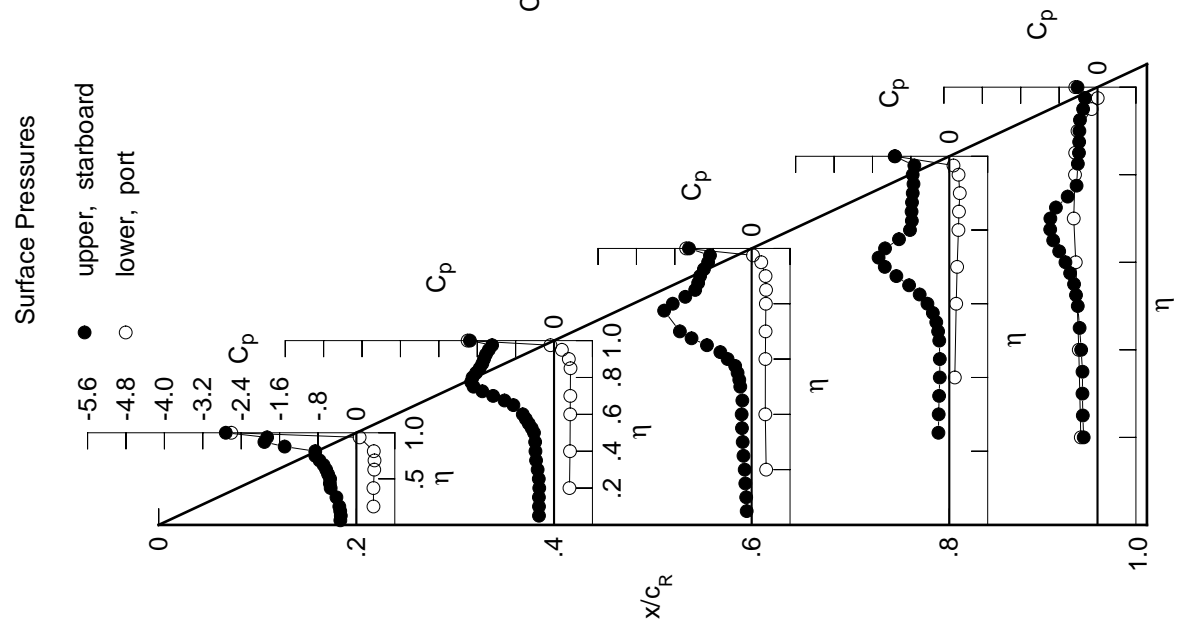
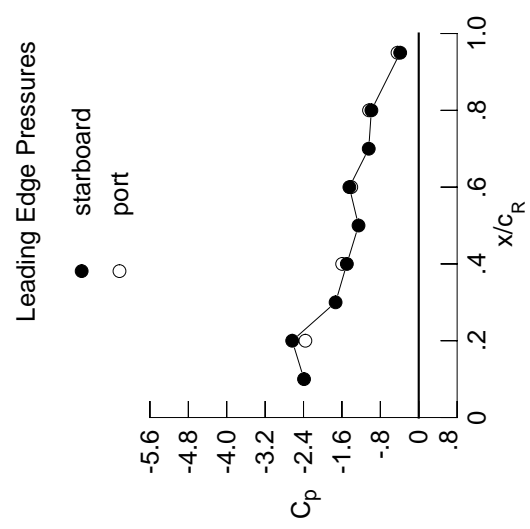

Table D2. Continued.

η	$x/c_R = 0.2$		$x/c_R = 0.4$		$x/c_R = 0.6$		$x/c_R = 0.8$		$x/c_R = 0.95$	
	$C_{p,u}$	$C_{p,u}$	$C_{p,u}$	$C_{p,u}$	$C_{p,u}$	$C_{p,u}$	$C_{p,u}$	$C_{p,u}$	$C_{p,u}$	$C_{p,u}$
0.050	-0.4306	-0.3816	-0.1450	*****	*****	*****	*****	*****	*****	*****
0.100	-0.4189	-0.3788	-0.1580	*****	*****	*****	*****	*****	*****	*****
0.150	-0.4370	-0.3829	-0.1737	*****	*****	*****	*****	*****	*****	*****
0.200	-0.4405	-0.3720	-0.1910	*****	*****	*****	*****	*****	*****	*****
0.250	*****	-0.3894	-0.2172	-0.2648	-0.3313	*****	*****	*****	*****	*****
0.300	-0.5349	-0.4010	-0.2302	-0.2591	-0.3377	*****	*****	*****	*****	*****
0.350	*****	-0.4035	-0.2461	-0.2581	-0.3386	*****	*****	*****	*****	*****
0.400	-0.6369	-0.4003	-0.2590	-0.2596	-0.3677	*****	*****	*****	*****	*****
0.450	-0.6278	-0.4025	-0.2590	-0.3004	-0.4040	*****	*****	*****	*****	*****
0.500	-0.6406	-0.4167	-0.3389	-0.3928	-0.4766	*****	*****	*****	*****	*****
0.525	*****	-0.4661	-0.3935	-0.4813	-0.5458	*****	*****	*****	*****	*****
0.550	-0.6735	-0.5529	-0.4781	-0.6012	-0.6224	*****	*****	*****	*****	*****
0.575	*****	-0.7009	-0.5899	-0.7616	-0.7472	*****	*****	*****	*****	*****
0.600	-0.7570	-0.9527	-0.8215	-0.9508	-0.8694	*****	*****	*****	*****	*****
0.625	*****	*****	-1.0287	-1.1424	-0.9858	*****	*****	*****	*****	*****
0.650	-1.0474	-1.6434	-1.3234	-1.3288	-1.0394	*****	*****	*****	*****	*****
0.675	*****	-1.9605	-1.6322	-1.4593	-0.9831	*****	*****	*****	*****	*****
0.700	-1.2181	-2.1434	-1.8471	-1.4772	-0.8664	*****	*****	*****	*****	*****
0.725	*****	-2.1772	*****	-1.3747	-0.6675	*****	*****	*****	*****	*****
0.750	-1.2203	-2.1087	*****	-1.1615	-0.4572	*****	*****	*****	*****	*****
0.775	*****	-1.9850	-1.1432	-0.9534	-0.4316	*****	*****	*****	*****	*****
0.800	-1.4028	-1.8511	-1.1015	-0.8814	*****	*****	*****	*****	*****	*****
0.825	*****	-1.7074	-1.1075	-0.8574	-0.4352	*****	*****	*****	*****	*****
0.850	-1.9957	-1.5762	-1.1255	-0.8556	-0.4031	*****	*****	*****	*****	*****
0.875	*****	-1.4699	-1.1477	-0.8496	-0.3777	*****	*****	*****	*****	*****
0.900	-1.9473	-1.4039	-1.1191	-0.8203	-0.3764	*****	*****	*****	*****	*****
0.925	*****	-1.3539	-1.1110	-0.7798	-0.3812	*****	*****	*****	*****	*****
0.950	-1.8618	-1.3004	-1.1284	-0.7816	-0.2875	*****	*****	*****	*****	*****
0.975	*****	-1.2577	-1.1019	-0.7492	-0.2473	*****	*****	*****	*****	*****
1.000	-2.6363	-1.4979	-1.4452	-0.9868	-0.3866	*****	*****	*****	*****	*****
-0.200	$C_{p,l}$	$C_{p,l}$	$C_{p,l}$	$C_{p,l}$	$C_{p,l}$	$C_{p,l}$	$C_{p,l}$	$C_{p,l}$	$C_{p,l}$	$C_{p,l}$
-0.400	0.4108	0.3648	0.3375	*****	*****	*****	*****	*****	*****	*****
-0.600	0.4087	0.3738	0.3180	0.1421	-0.4010	*****	*****	*****	*****	*****
-0.700	0.4205	0.3784	0.3189	0.1714	-0.4898	*****	*****	*****	*****	*****
-0.800	0.4185	0.3771	0.3223	0.1886	-0.5215	*****	*****	*****	*****	*****
-0.850	0.3876	*****	0.3235	0.2161	-0.4753	*****	*****	*****	*****	*****
-0.900	*****	0.3624	0.3210	0.2258	-0.4603	*****	*****	*****	*****	*****
-0.950	*****	0.3101	0.2949	0.2351	-0.3989	*****	*****	*****	*****	*****
-0.975	0.0197	0.1324	0.1676	0.1875	-0.1045	*****	*****	*****	*****	*****
-1.000	*****	-0.1391	-0.0487	0.0528	0.0045	*****	*****	*****	*****	*****
		-2.3614	-1.5950	-1.4058	-1.0349	-0.4415	*****	*****	*****	*****

Medium Radius L.E.
 Run No. = 23 , Point No. = 476
 $C_N = 0.848$, $C_m = -0.1174$
 $\alpha = 18.4^\circ$, $M_\infty = 0.599$
 $R_{mac} = 59.8 \times 10^6$



x/c_R	starb'd C_p	port C_p
0.10	-2.3898	*****
0.20	-2.6363	-2.3614
0.30	-1.7322	*****
0.40	-1.4979	-1.5950
0.50	-1.2541	*****
0.60	-1.4452	-1.4058
0.70	-1.0417	*****
0.80	-0.9868	-1.0349
0.90	*****	*****
0.95	-0.3866	-0.4415

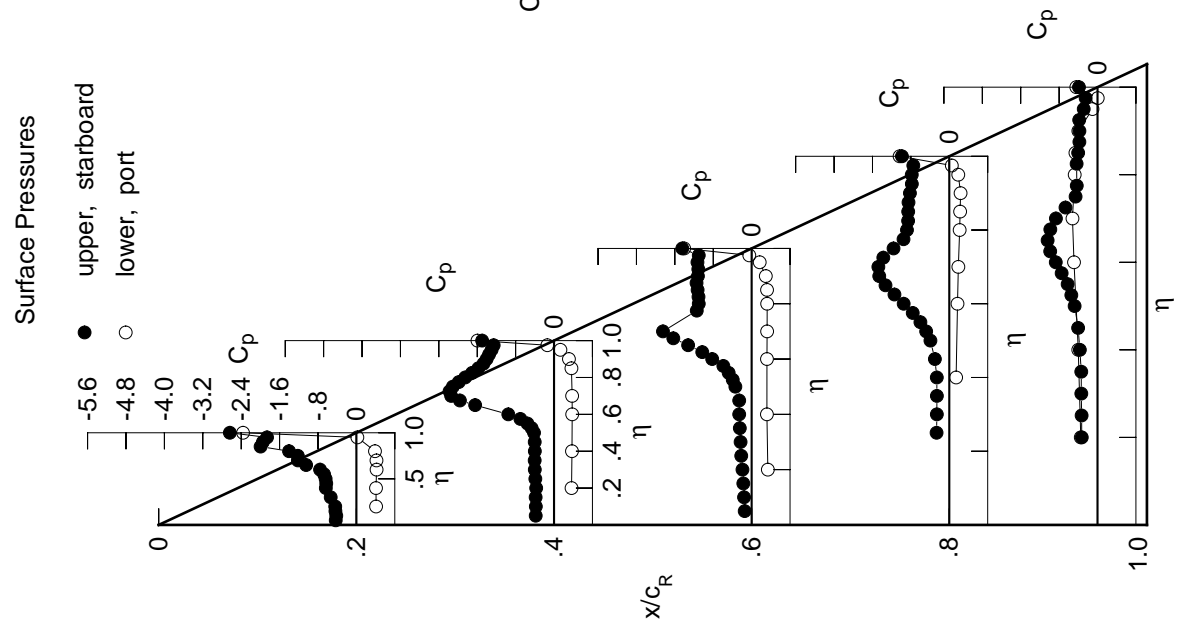
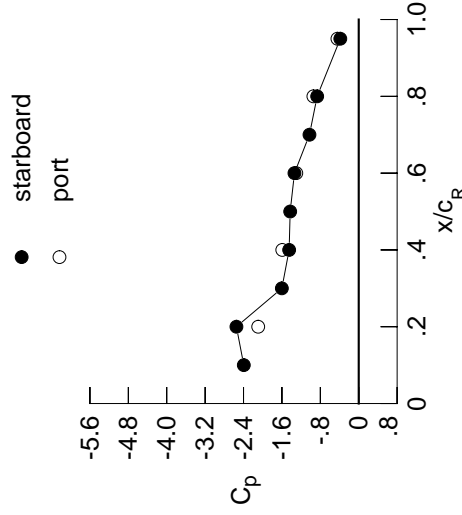

Table D2. Continued.

η	$x/c_R = .2$		$x/c_R = .4$		$x/c_R = .6$		$x/c_R = .8$		$x/c_R = .95$	
	$C_{p,u}$	$C_{p,u}$	$C_{p,u}$	$C_{p,u}$	$C_{p,u}$	$C_{p,u}$	$C_{p,u}$	$C_{p,u}$	$C_{p,u}$	$C_{p,u}$
0.050	-0.5102	-0.4528	-0.1937	*****	*****	*****	*****	*****	*****	*****
0.100	-0.5007	-0.4515	-0.2073	*****	*****	*****	*****	*****	*****	*****
0.150	-0.5059	-0.4494	-0.2248	*****	*****	*****	*****	*****	*****	*****
0.200	-0.5268	-0.4497	-0.2473	*****	*****	*****	*****	*****	*****	-0.3485
0.250	*****	-0.4792	-0.2806	-0.2912	-0.3569	*****	*****	*****	*****	*****
0.300	-0.5895	-0.4787	-0.3060	-0.2863	-0.3676	*****	*****	*****	*****	*****
0.350	*****	-0.4807	-0.3368	-0.2972	-0.3737	*****	*****	*****	*****	*****
0.400	-0.5930	-0.4858	-0.3840	-0.3192	-0.4124	*****	*****	*****	*****	*****
0.450	-0.6008	-0.5124	-0.4468	-0.3992	-0.4689	*****	*****	*****	*****	*****
0.500	-0.6265	-0.5828	-0.6370	-0.5607	-0.5852	*****	*****	*****	*****	*****
0.525	*****	-0.6753	-0.7684	-0.6898	-0.6787	*****	*****	*****	*****	*****
0.550	-0.7130	-0.8095	-0.9288	-0.8529	-0.7800	*****	*****	*****	*****	*****
0.575	*****	-1.0035	-1.1041	-1.0540	-0.9114	*****	*****	*****	*****	*****
0.600	-1.0525	-1.2601	-1.3657	-1.2701	-1.0080	*****	*****	*****	*****	*****
0.625	*****	*****	-1.5439	-1.4818	-1.0458	*****	*****	*****	*****	*****
0.650	-1.7616	-1.9020	-1.7352	-1.6612	-1.0096	*****	*****	*****	*****	*****
0.675	*****	-2.2177	-1.8263	-1.6934	-0.8834	*****	*****	*****	*****	*****
0.700	-2.0904	-2.4676	-1.7162	-1.5359	-0.7108	*****	*****	*****	*****	*****
0.725	*****	-2.6104	*****	-1.2979	-0.5128	*****	*****	*****	*****	*****
0.750	-2.1185	-2.2408	*****	-1.0304	-0.4322	*****	*****	*****	*****	*****
0.775	*****	-1.9547	-1.2609	-0.9163	-0.4540	*****	*****	*****	*****	*****
0.800	-2.1095	-1.7891	-1.2517	-0.8973	*****	*****	*****	*****	*****	*****
0.825	*****	-1.7062	-1.2491	-0.8769	-0.4336	*****	*****	*****	*****	*****
0.850	-1.9848	-1.6646	-1.2355	-0.8789	-0.3929	*****	*****	*****	*****	*****
0.875	*****	-1.6356	-1.2215	-0.8837	-0.3710	*****	*****	*****	*****	*****
0.900	-1.7092	-1.5618	-1.1900	-0.8544	-0.3737	*****	*****	*****	*****	*****
0.925	*****	-1.4035	-1.1700	-0.7903	-0.3940	*****	*****	*****	*****	*****
0.950	-1.6396	-1.3401	-1.1579	-0.7767	-0.3095	*****	*****	*****	*****	*****
0.975	*****	-1.3221	-1.1396	-0.7595	-0.2722	*****	*****	*****	*****	*****
1.000	-2.5484	-1.4499	-1.3389	-0.8660	-0.3839	*****	*****	*****	*****	*****
-0.200	$C_{p,l}$	0.4618	0.4098	0.3731	*****	-0.3161	*****	*****	*****	*****
-0.400	*****	0.4599	0.4159	0.3561	0.1731	-0.4096	*****	*****	*****	*****
-0.600	*****	0.4659	0.4179	0.3547	0.1995	-0.5108	*****	*****	*****	*****
-0.700	*****	0.4550	0.4125	0.3568	0.2191	-0.5279	*****	*****	*****	*****
-0.800	*****	0.4082	*****	0.3520	0.2413	-0.4639	*****	*****	*****	*****
-0.850	*****	0.3737	0.3420	0.2480	-0.4417	*****	*****	*****	*****	*****
-0.900	*****	0.2999	0.3010	0.2488	-0.3716	*****	*****	*****	*****	*****
-0.950	*****	-0.0271	0.0830	0.1384	0.1777	-0.0864	*****	*****	*****	*****
-0.975	*****	-0.2324	-0.1128	0.0157	-0.0010	*****	*****	*****	*****	*****
-1.000	*****	-2.0944	-1.5925	-1.3011	-0.9451	-0.4439	*****	*****	*****	*****

Medium Radius L.E.
 Run No. = 23 , Point No. = 477
 $C_N = 0.965$, $C_m = -0.1301$
 $\alpha = 20.5^\circ$, $M_\infty = 0.601$
 $R_{mac} = 59.8 \times 10^6$

Leading Edge Pressures



x/c_R	starb'd C_p	port C_p
0.10	-2.3943	*****
0.20	-2.5484	-2.0944
0.30	-1.6016	*****
0.40	-1.4499	-1.5925
0.50	-1.4283	*****
0.60	-1.3389	-1.3011
0.70	-1.0267	*****
0.80	-0.8660	-0.9451
0.90	*****	*****
0.95	-0.3839	-0.4439

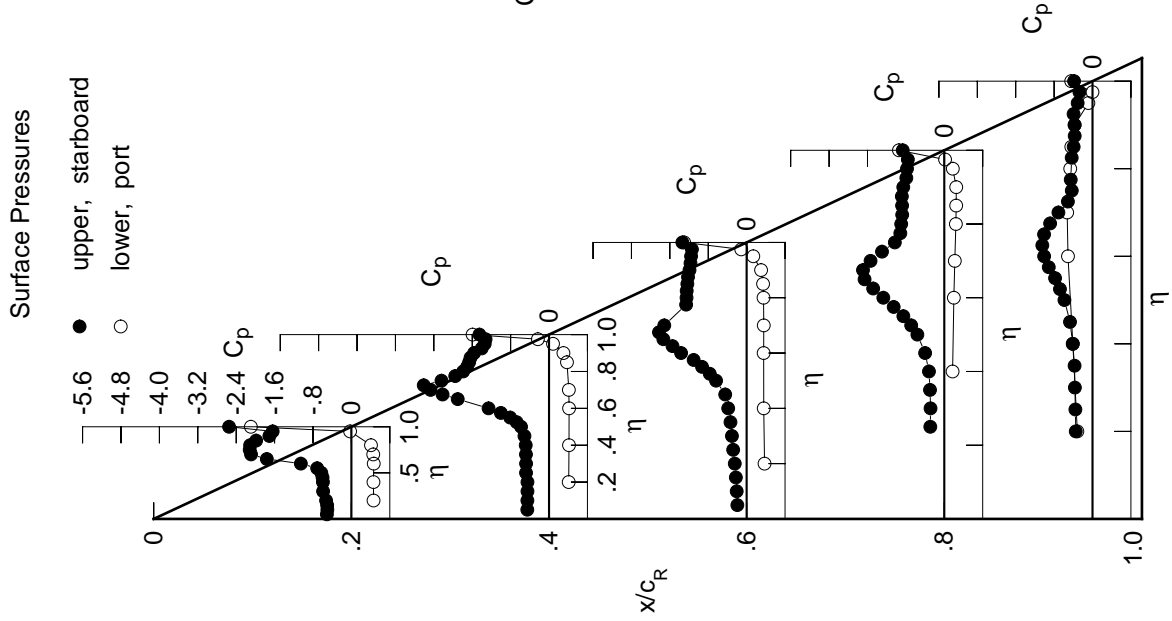

Table D2. Continued.

η	$x/c_R = .2$		$x/c_R = .4$		$x/c_R = .6$		$x/c_R = .8$		$x/c_R = .95$	
	$C_{p,u}$	$C_{p,u}$	$C_{p,u}$	$C_{p,u}$	$C_{p,u}$	$C_{p,u}$	$C_{p,u}$	$C_{p,u}$	$C_{p,u}$	$C_{p,u}$
0.050	-0.6050	-0.5491	-0.2311	*****	*****	*****	*****	*****	*****	*****
0.100	-0.5988	-0.5449	-0.2444	*****	*****	*****	*****	*****	*****	*****
0.150	-0.6110	-0.5480	-0.2631	*****	*****	*****	*****	*****	*****	*****
0.200	-0.6511	-0.5539	-0.2854	*****	*****	*****	*****	*****	*****	-0.3646
0.250	*****	-0.5858	-0.3173	-0.3299	-0.3299	-0.3299	-0.3299	-0.3299	-0.3299	-0.3920
0.300	-0.6602	-0.5999	-0.3467	-0.3337	-0.3337	-0.4071	-0.4071	-0.4071	-0.4071	-0.4071
0.350	*****	-0.6198	-0.3990	-0.3575	-0.3575	-0.4231	-0.4231	-0.4231	-0.4231	-0.4231
0.400	-0.6740	-0.6587	-0.4809	-0.4085	-0.4085	-0.4802	-0.4802	-0.4802	-0.4802	-0.4802
0.450	-0.6790	-0.7594	-0.6043	-0.5315	-0.5315	-0.5663	-0.5663	-0.5663	-0.5663	-0.5663
0.500	-0.7134	-0.9439	-0.8812	-0.7475	-0.7475	-0.7167	-0.7167	-0.7167	-0.7167	-0.7167
0.525	*****	-1.1082	-1.0675	-0.9023	-0.8172	-0.8172	-0.8172	-0.8172	-0.8172	-0.8172
0.550	-0.9156	-1.3094	-1.2761	-1.0847	-1.0847	-0.9042	-0.9042	-0.9042	-0.9042	-0.9042
0.575	*****	-1.5269	-1.4940	-1.2976	-0.9773	-0.9773	-0.9773	-0.9773	-0.9773	-0.9773
0.600	-1.6085	-1.7770	-1.7769	-1.5203	-1.5203	-0.9800	-0.9800	-0.9800	-0.9800	-0.9800
0.625	*****	*****	-1.9886	-1.7391	-1.7391	-0.9444	-0.9444	-0.9444	-0.9444	-0.9444
0.650	-2.4675	-2.2967	-2.2038	-1.9140	-1.9140	-0.8496	-0.8496	-0.8496	-0.8496	-0.8496
0.675	*****	-2.2969	-2.2745	-1.6611	-1.6611	-0.6838	-0.6838	-0.6838	-0.6838	-0.6838
0.700	-2.8163	-1.8995	-1.8052	-1.3713	-1.3713	-0.5072	-0.5072	-0.5072	-0.5072	-0.5072
0.725	*****	-1.7510	*****	-1.0991	-0.4418	-0.4418	-0.4418	-0.4418	-0.4418	-0.4418
0.750	-2.6111	-1.7092	*****	-0.9602	-0.4625	-0.4625	-0.4625	-0.4625	-0.4625	-0.4625
0.775	*****	-1.7180	-1.3240	-0.9289	-0.4720	-0.4720	-0.4720	-0.4720	-0.4720	-0.4720
0.800	-2.4422	-1.7247	-1.3060	-0.9136	-0.9136	*****	*****	*****	*****	*****
0.825	*****	-1.7384	-1.3012	-0.8991	-0.4313	-0.4313	-0.4313	-0.4313	-0.4313	-0.4313
0.850	-2.0962	-1.7275	-1.3060	-0.9151	-0.3978	-0.3978	-0.3978	-0.3978	-0.3978	-0.3978
0.875	*****	-1.6866	-1.3139	-0.9198	-0.3789	-0.3789	-0.3789	-0.3789	-0.3789	-0.3789
0.900	-1.8506	-1.6607	-1.2601	-0.8860	-0.3692	-0.3692	-0.3692	-0.3692	-0.3692	-0.3692
0.925	*****	-1.6452	-1.2025	-0.8274	-0.3705	-0.3705	-0.3705	-0.3705	-0.3705	-0.3705
0.950	-1.6920	-1.6370	-1.1797	-0.8044	-0.3222	-0.3222	-0.3222	-0.3222	-0.3222	-0.3222
0.975	*****	-1.6151	-1.1700	-0.7903	-0.2944	-0.2944	-0.2944	-0.2944	-0.2944	-0.2944
1.000	-2.2360	-1.6465	-1.2890	-0.8361	-0.3636	-0.3636	-0.3636	-0.3636	-0.3636	-0.3636
-0.200	$C_{p,l}$	$C_{p,l}$	$C_{p,l}$	$C_{p,l}$	$C_{p,l}$	$C_{p,l}$	$C_{p,l}$	$C_{p,l}$	$C_{p,l}$	$C_{p,l}$
-0.400	0.5152	0.4543	0.4102	*****	*****	-0.3241	-0.3241	-0.3241	-0.3241	-0.3241
-0.600	0.5116	0.4599	0.3914	0.2023	0.2023	-0.4253	-0.4253	-0.4253	-0.4253	-0.4253
-0.700	0.5100	0.4578	0.3904	0.2274	0.2274	-0.5152	-0.5152	-0.5152	-0.5152	-0.5152
-0.800	0.4900	0.4484	0.3894	0.2459	0.2459	-0.5184	-0.5184	-0.5184	-0.5184	-0.5184
-0.850	0.4260	*****	0.3790	0.2655	0.2655	-0.4435	-0.4435	-0.4435	-0.4435	-0.4435
-0.900	*****	0.3836	0.3609	0.2692	0.2692	-0.4157	-0.4157	-0.4157	-0.4157	-0.4157
-0.950	*****	0.2873	0.3038	0.2602	0.3398	0.3398	0.3398	0.3398	0.3398	0.3398
-0.975	-0.0802	0.0265	0.1073	0.1624	0.1624	-0.0669	-0.0669	-0.0669	-0.0669	-0.0669
-1.000	*****	-0.3420	-0.1779	-0.0289	-0.0046	-0.0046	-0.0046	-0.0046	-0.0046	-0.0046
-1.000	-1.9765	-1.7024	-1.2491	-0.9061	-0.4389	-0.4389	-0.4389	-0.4389	-0.4389	-0.4389

Medium Radius L.E.
 Run No. = 23 , Point No. = 478
 $C_N = 1.079$, $C_m = -0.1420$
 $\alpha = 22.5^\circ$, $M_\infty = 0.599$
 $R_{mac} = 59.7 \times 10^6$

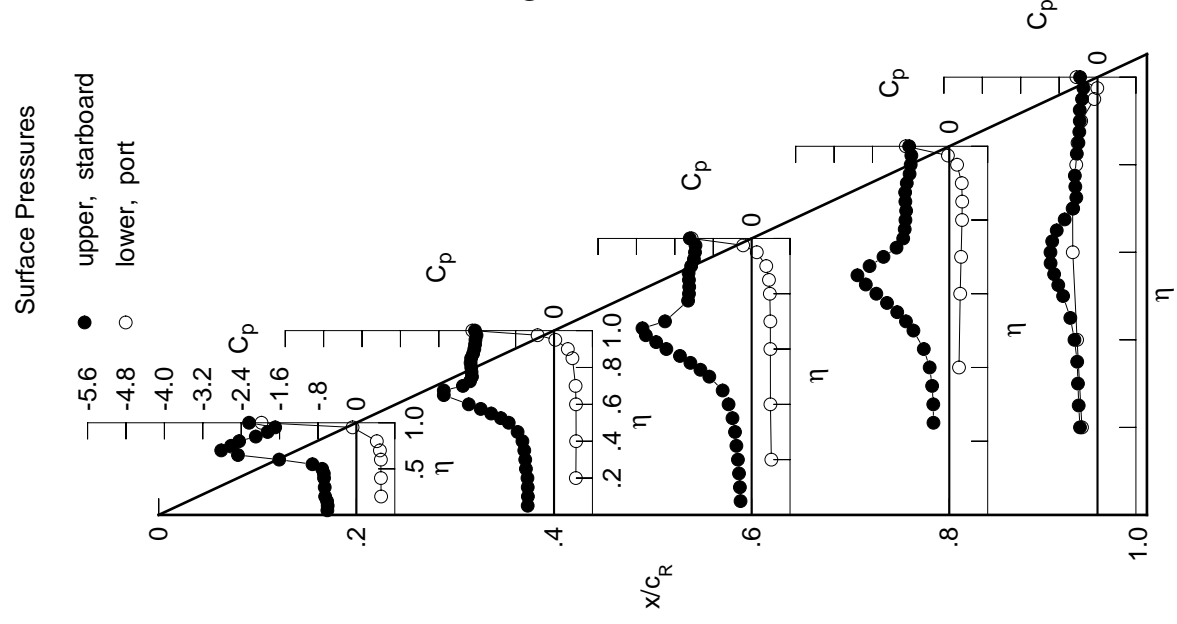
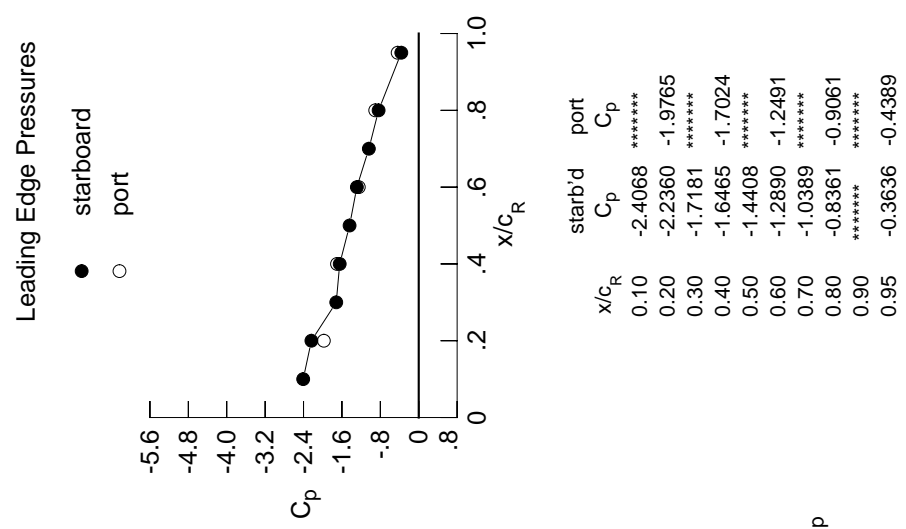
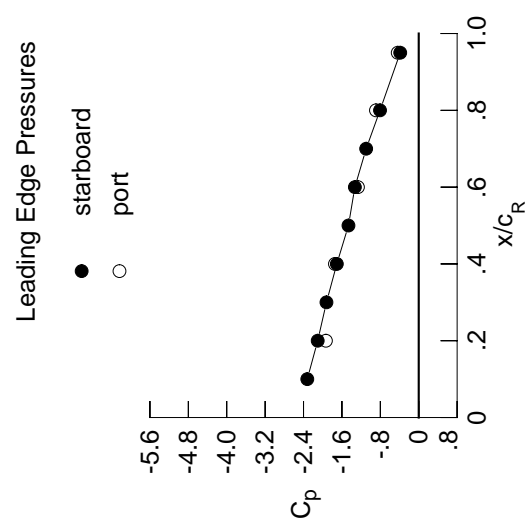

Table D2. Continued.

η	x/c_R .2	x/c_R .4	x/c_R .6	x/c_R .8	x/c_R .95
	$C_{p,u}$	$C_{p,u}$	$C_{p,u}$	$C_{p,u}$	$C_{p,u}$
0.050	-0.7061	-0.6354	-0.2689	*****	*****
0.100	-0.6950	-0.6334	-0.2837	*****	*****
0.150	-0.7396	-0.6358	-0.3048	*****	*****
0.200	-0.7483	-0.6327	-0.3324	*****	-0.3700
0.250	*****	-0.6829	-0.3705	-0.3871	-0.4250
0.300	-0.7450	-0.7015	-0.4116	-0.4058	-0.4570
0.350	*****	-0.7585	-0.4871	-0.4562	-0.4852
0.400	-0.7838	-0.8598	-0.6033	-0.5451	-0.5646
0.450	-0.8345	-1.0674	-0.7779	-0.7154	-0.6699
0.500	-1.0204	-1.3685	-1.1030	-0.9754	-0.8102
0.525	*****	-1.5758	-1.3046	-1.1436	-0.8741
0.550	-1.5077	-1.8085	-1.5161	-1.3311	-0.8922
0.575	*****	-2.0389	-1.7260	-1.5382	-0.9046
0.600	-2.2554	-2.2307	-1.9937	-1.7351	-0.8610
0.625	*****	*****	-2.1948	-1.7768	-0.7797
0.650	-2.8721	-2.6004	-2.3859	-1.5764	-0.6550
0.675	*****	-2.3591	-1.8346	-1.3305	-0.5071
0.700	-3.0357	-2.0701	-1.5512	-1.0777	-0.4529
0.725	*****	-1.9416	*****	-0.9532	-0.4914
0.750	-2.6476	-1.8871	*****	-0.9218	-0.4976
0.775	*****	-1.8719	-1.4245	-0.9049	-0.4941
0.800	-2.3356	-1.8532	-1.4256	-0.8950	*****
0.825	*****	-1.8507	-1.4504	-0.8929	-0.4598
0.850	-2.1579	-1.8432	-1.4779	-0.8922	-0.4326
0.875	*****	-1.8033	-1.4510	-0.8872	-0.4190
0.900	-1.9663	-1.7563	-1.3521	-0.8655	-0.4006
0.925	*****	-1.7183	-1.2865	-0.8333	-0.3843
0.950	-1.8624	-1.7055	-1.2703	-0.8127	-0.3583
0.975	*****	-1.6944	-1.2665	-0.7963	-0.3429
1.000	-2.1046	-1.7067	-1.3306	-0.8066	-0.3859
	$C_{p,l}$	$C_{p,l}$	$C_{p,l}$	$C_{p,l}$	$C_{p,l}$
-0.200	0.5671	0.5014	0.4477	*****	-0.3270
-0.400	0.5623	0.5043	0.4304	0.2339	0.4260
-0.600	0.5526	0.4987	0.4264	0.2570	-0.5129
-0.700	0.5219	0.4842	0.4236	0.2749	-0.5053
-0.800	0.4403	*****	0.4049	0.2909	-0.4224
-0.850	*****	0.3939	0.3781	0.2906	-0.3925
-0.900	*****	0.2758	0.3038	0.2708	-0.3124
-0.950	-0.1366	-0.0241	0.0707	0.1453	-0.0522
-0.975	*****	-0.4370	-0.2478	-0.0745	-0.0153
-1.000	-1.9340	-1.7460	-1.2661	-0.8912	-0.4375

Medium Radius L.E.
 Run No. = 23 , Point No. = 479
 $C_N = 1.179$, $C_m = -0.1489$
 $\alpha = 24.6^\circ$, $M_\infty = 0.599$
 $R_{mac} = 59.9 \times 10^6$



x/c_R	starb'd C_p	port C_p
0.10	-2.3218	*****
0.20	-2.1046	-1.9340
0.30	-1.9221	*****
0.40	-1.7067	-1.7460
0.50	-1.4641	*****
0.60	-1.3306	-1.2661
0.70	-1.0953	*****
0.80	-0.8066	-0.8912
0.90	*****	*****
0.95	-0.3859	-0.4375

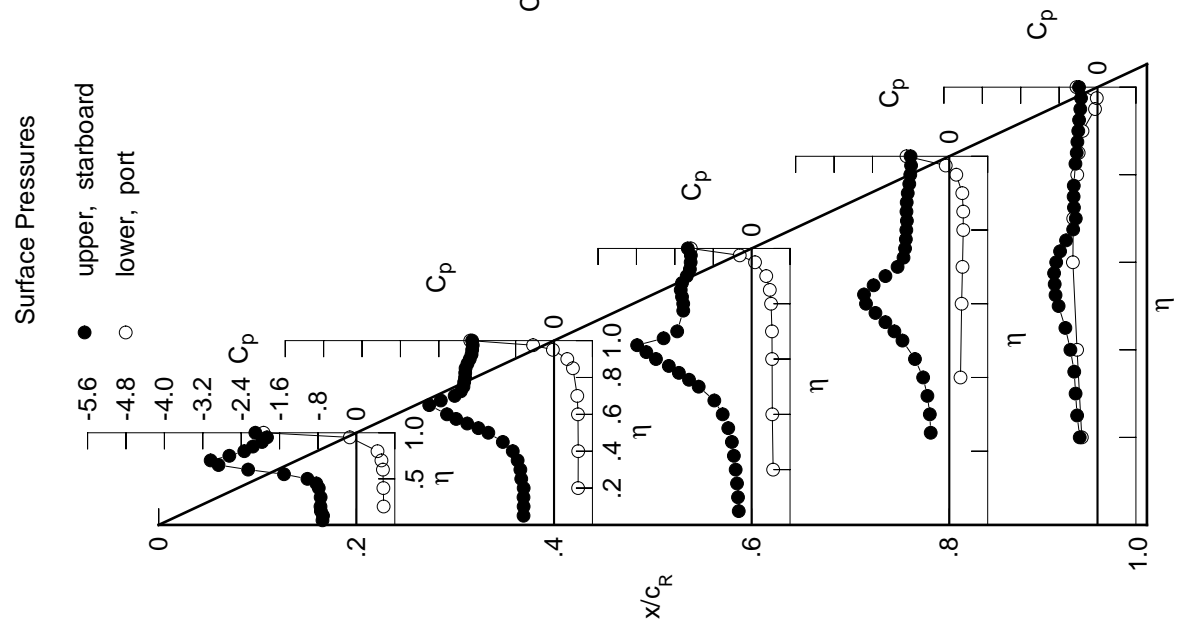

Table D2. Concluded.

η	$x/c_R = .2$		$x/c_R = .4$		$x/c_R = .6$		$x/c_R = .8$		$x/c_R = .95$	
	$C_{p,u}$	$C_{p,l}$	$C_{p,u}$	$C_{p,l}$	$C_{p,u}$	$C_{p,l}$	$C_{p,u}$	$C_{p,l}$	$C_{p,u}$	$C_{p,l}$
0.050	-0.8229	-0.7081	-0.3049	*****	*****	*****	*****	*****	*****	*****
0.100	-0.8105	-0.7087	-0.3236	*****	*****	*****	*****	*****	*****	*****
0.150	-0.8308	-0.7124	-0.3484	*****	*****	*****	*****	*****	*****	*****
0.200	-0.8615	-0.7125	-0.3820	*****	*****	*****	*****	*****	*****	*****
0.250	*****	-0.7440	-0.4325	-0.4542	-0.4542	-0.4542	-0.4542	-0.4542	-0.4542	-0.4542
0.300	-0.8837	-0.7837	-0.4909	-0.4919	-0.4937	*****	*****	*****	*****	*****
0.350	*****	-0.8696	-0.5918	-0.5687	-0.5403	*****	*****	*****	*****	*****
0.400	-0.9888	-1.0123	-0.7425	-0.6955	-0.6327	*****	*****	*****	*****	*****
0.450	-1.1390	-1.2768	-0.9545	-0.9058	-0.7376	*****	*****	*****	*****	*****
0.500	-1.4826	-1.6289	-1.3074	-1.1963	-0.8330	*****	*****	*****	*****	*****
0.525	*****	-1.8546	-1.5094	-1.3718	-0.8659	*****	*****	*****	*****	*****
0.550	-2.0543	-2.1151	-1.7196	-1.5551	-0.8517	*****	*****	*****	*****	*****
0.575	*****	-2.3402	-1.9170	-1.7392	-0.8372	*****	*****	*****	*****	*****
0.600	-2.6577	-2.5329	-2.1712	-1.7873	-0.7682	*****	*****	*****	*****	*****
0.625	*****	*****	-2.3532	-1.5713	-0.6764	*****	*****	*****	*****	*****
0.650	-2.6379	-2.8729	-1.8869	-1.2995	-0.5675	*****	*****	*****	*****	*****
0.675	*****	-2.3323	-1.5617	-1.0385	-0.4904	*****	*****	*****	*****	*****
0.700	-2.4385	-2.1873	-1.5010	-0.8905	-0.5225	*****	*****	*****	*****	*****
0.725	*****	-2.1610	*****	-0.8616	-0.5622	*****	*****	*****	*****	*****
0.750	-2.4638	-2.1415	*****	-0.8430	-0.5689	*****	*****	*****	*****	*****
0.775	*****	-2.1074	-1.4850	-0.8331	-0.5735	*****	*****	*****	*****	*****
0.800	-2.5191	-2.0518	-1.5083	-0.8230	*****	*****	*****	*****	*****	*****
0.825	*****	-2.0223	-1.5589	-0.8135	-0.5627	*****	*****	*****	*****	*****
0.850	-2.3443	-1.9965	-1.5804	-0.8188	-0.5396	*****	*****	*****	*****	*****
0.875	*****	-1.9513	-1.5373	-0.8194	-0.5342	*****	*****	*****	*****	*****
0.900	-2.0906	-1.8801	-1.4448	-0.8170	-0.5245	*****	*****	*****	*****	*****
0.925	*****	-1.8084	-1.3982	-0.8061	-0.5161	*****	*****	*****	*****	*****
0.950	-2.1178	-1.7751	-1.3892	-0.7959	-0.5029	*****	*****	*****	*****	*****
0.975	*****	-1.7628	-1.3874	-0.7845	-0.4985	*****	*****	*****	*****	*****
1.000	-2.3445	-1.7643	-1.4089	-0.7833	-0.5038	*****	*****	*****	*****	*****
-0.200	0.6194	0.5461	0.4857	*****	*****	*****	*****	*****	*****	*****
-0.400	0.6108	0.5485	0.4673	0.2643	-0.4301	*****	*****	*****	*****	*****
-0.600	0.5913	0.5372	0.4596	0.2865	-0.5066	*****	*****	*****	*****	*****
-0.700	0.5493	0.5179	0.4555	0.3021	-0.4937	*****	*****	*****	*****	*****
-0.800	0.4479	*****	0.4280	0.3141	-0.4090	*****	*****	*****	*****	*****
-0.850	*****	0.3993	0.3912	0.3095	-0.3784	*****	*****	*****	*****	*****
-0.900	*****	0.2595	0.2985	0.2781	-0.2981	*****	*****	*****	*****	*****
-0.950	-0.2022	-0.0777	0.0298	0.1261	-0.0520	*****	*****	*****	*****	*****
-0.975	*****	-0.5296	-0.3219	-0.1202	-0.0403	*****	*****	*****	*****	*****
-1.000	-2.0083	-1.8518	-1.3161	-0.8785	-0.4764	*****	*****	*****	*****	*****

Medium Radius L.E.
 Run No. = 23 , Point No. = 480
 $C_N = 1.276$, $C_m = -0.1569$
 $\alpha = 26.7^\circ$, $M_\infty = 0.598$
 $R_{mac} = 59.8 \times 10^6$

Leading Edge Pressures

● starboard
 ○ port

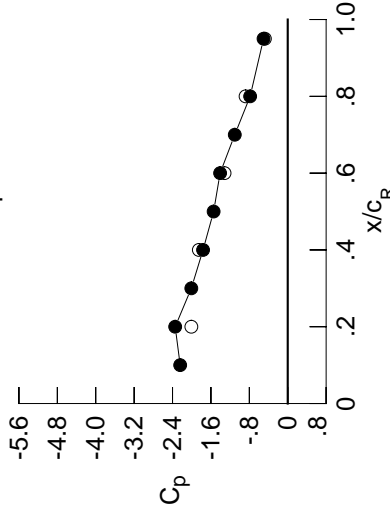

x/c_R	starb'd C_p	port C_p
0.10	-2.2406	*****
0.20	-2.3445	-2.0083
0.30	-2.0091	*****
0.40	-1.7643	-1.8518
0.50	-1.5438	*****
0.60	-1.4089	-1.3161
0.70	-1.1035	*****
0.80	-0.7833	-0.8785
0.90	*****	*****
0.95	-0.5038	-0.4764

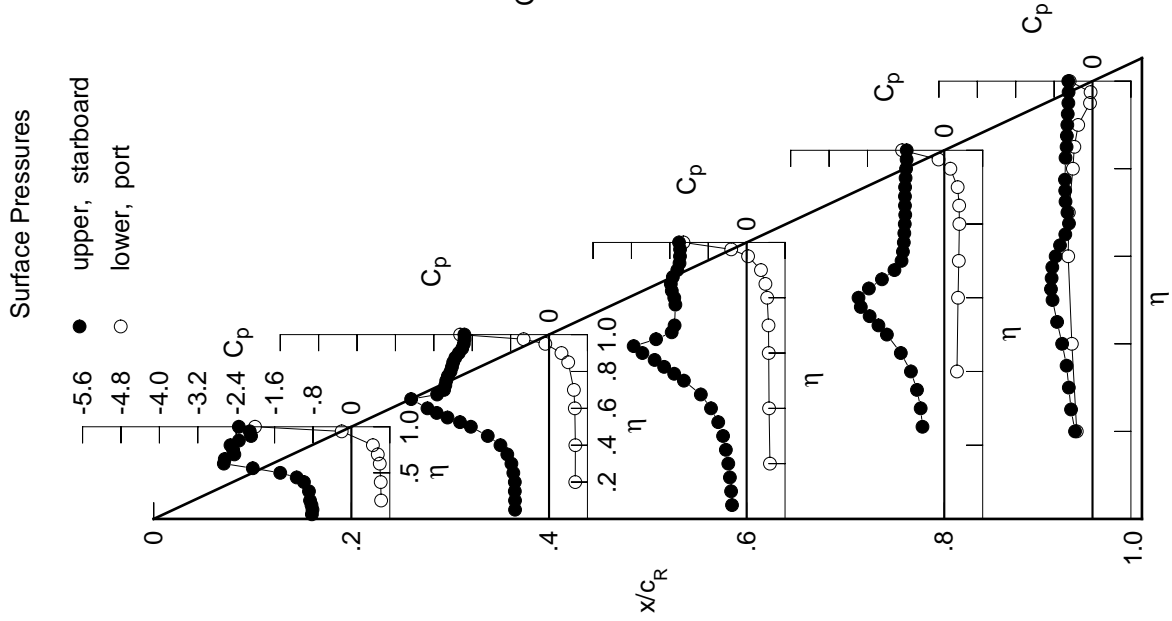
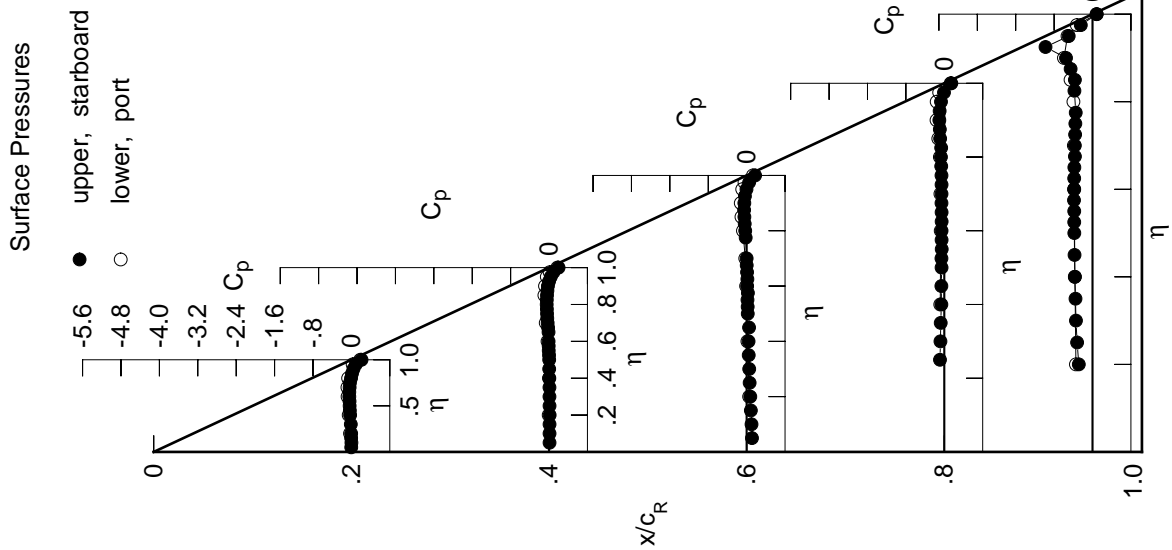

Table D3. Tabulations and Plots of Surface Pressure Coefficients.

η	$x/c_R = .2$		$x/c_R = .4$		$x/c_R = .6$		$x/c_R = .8$		$x/c_R = .95$	
	$C_{p,u}$	$C_{p,u}$	$C_{p,u}$	$C_{p,u}$	$C_{p,u}$	$C_{p,u}$	$C_{p,u}$	$C_{p,u}$	$C_{p,u}$	$C_{p,u}$
0.050	-0.0032	0.0102	0.1110	0.1110	0.0896	0.0896	0.0896	0.0896	0.0896	0.0896
0.100	0.0009	0.0107	0.1014	0.1014	0.0797	0.0797	0.0797	0.0797	0.0797	0.0797
0.150	-0.0046	0.0102	0.0878	0.0878	0.0740	0.0740	0.0740	0.0740	0.0740	0.0740
0.200	-0.0048	0.0131	0.0760	0.0760	0.0611	0.0611	0.0611	0.0611	0.0611	0.0611
0.250	0.0000	0.0107	0.0623	0.0623	0.0536	0.0536	0.0536	0.0536	0.0536	0.0536
0.300	-0.0119	0.0091	0.0536	0.0536	0.0432	0.0432	0.0432	0.0432	0.0432	0.0432
0.350	0.0000	0.0084	0.0432	0.0432	0.0398	0.0398	0.0398	0.0398	0.0398	0.0398
0.400	-0.0263	0.0060	0.0398	0.0398	0.0361	0.0361	0.0361	0.0361	0.0361	0.0361
0.450	-0.0321	0.0030	0.0361	0.0361	0.0323	0.0323	0.0323	0.0323	0.0323	0.0323
0.500	-0.0372	0.0031	0.0233	0.0233	0.0267	0.0267	0.0267	0.0267	0.0267	0.0267
0.525	0.0000	0.0003	0.0213	0.0213	0.0213	0.0213	0.0213	0.0213	0.0213	0.0213
0.550	-0.0385	-0.0065	0.0178	0.0178	0.0178	0.0178	0.0178	0.0178	0.0178	0.0178
0.575	0.0000	-0.0069	0.0261	0.0261	0.0155	0.0155	0.0155	0.0155	0.0155	0.0155
0.600	-0.0428	-0.0095	0.0104	0.0104	0.0155	0.0155	0.0155	0.0155	0.0155	0.0155
0.625	0.0000	0.0000	0.0155	0.0155	0.0155	0.0155	0.0155	0.0155	0.0155	0.0155
0.650	-0.0432	-0.0105	0.0088	0.0088	0.0155	0.0155	0.0155	0.0155	0.0155	0.0155
0.675	0.0000	-0.0203	0.0013	0.0013	0.0155	0.0155	0.0155	0.0155	0.0155	0.0155
0.700	-0.0370	-0.0291	-0.0002	-0.0002	0.0155	0.0155	0.0155	0.0155	0.0155	0.0155
0.725	0.0000	-0.0367	0.0000	0.0000	0.0155	0.0155	0.0155	0.0155	0.0155	0.0155
0.750	-0.0301	-0.0418	0.0000	0.0000	0.0155	0.0155	0.0155	0.0155	0.0155	0.0155
0.775	0.0000	-0.0450	-0.0196	-0.0196	0.0155	0.0155	0.0155	0.0155	0.0155	0.0155
0.800	-0.0076	-0.0488	-0.0297	-0.0297	0.0155	0.0155	0.0155	0.0155	0.0155	0.0155
0.825	0.0000	-0.0462	-0.0397	-0.0397	0.0155	0.0155	0.0155	0.0155	0.0155	0.0155
0.850	0.0117	-0.0423	-0.0474	-0.0474	0.0155	0.0155	0.0155	0.0155	0.0155	0.0155
0.875	0.0000	-0.0337	-0.0531	-0.0531	0.0155	0.0155	0.0155	0.0155	0.0155	0.0155
0.900	0.0429	-0.0231	-0.0481	-0.0481	0.0155	0.0155	0.0155	0.0155	0.0155	0.0155
0.925	0.0000	0.0004	-0.0358	-0.0358	0.0155	0.0155	0.0155	0.0155	0.0155	0.0155
0.950	0.0920	0.0370	-0.0035	-0.0035	0.0155	0.0155	0.0155	0.0155	0.0155	0.0155
0.975	0.0000	0.0921	0.0522	0.0522	0.0155	0.0155	0.0155	0.0155	0.0155	0.0155
1.000	0.2109	0.1986	0.1764	0.1764	0.1465	0.1465	0.1465	0.1465	0.1465	0.1465
-0.200	-0.0287	-0.0071	0.0521	0.0521	0.0521	0.0521	0.0521	0.0521	0.0521	0.0521
-0.400	-0.0561	-0.0009	0.0159	0.0159	0.0842	0.0842	0.0842	0.0842	0.0842	0.0842
-0.600	-0.0792	-0.0314	-0.0110	-0.0110	0.0741	0.0741	0.0741	0.0741	0.0741	0.0741
-0.700	-0.0823	-0.0692	-0.0291	-0.0291	0.0805	0.0805	0.0805	0.0805	0.0805	0.0805
-0.800	-0.0681	0.0000	-0.0767	-0.0767	0.0923	0.0923	0.0923	0.0923	0.0923	0.0923
-0.850	0.0000	-0.0968	-0.1078	-0.1078	0.1245	0.1245	0.1245	0.1245	0.1245	0.1245
-0.900	0.0000	-0.0837	-0.1225	-0.1225	0.1616	0.1616	0.1616	0.1616	0.1616	0.1616
-0.950	0.0262	-0.0462	-0.0921	-0.0921	0.1585	0.1585	0.1585	0.1585	0.1585	0.1585
-0.975	0.0000	0.0127	-0.0452	-0.0452	0.1067	0.1067	0.1067	0.1067	0.1067	0.1067
-1.000	0.1848	0.1735	0.1304	0.1304	0.1326	0.1326	0.1326	0.1326	0.1326	0.1326

Medium Radius L.E.
 Run No. = 30 , Point No. = 598
 $C_N = -0.024$, $C_m = 0.0013$
 $\alpha = -0.7^\circ$, $M_\infty = 0.598$
 $R_{mac} = 101.0 \times 10^6$



Leading Edge Pressures

● starboard
 ○ port

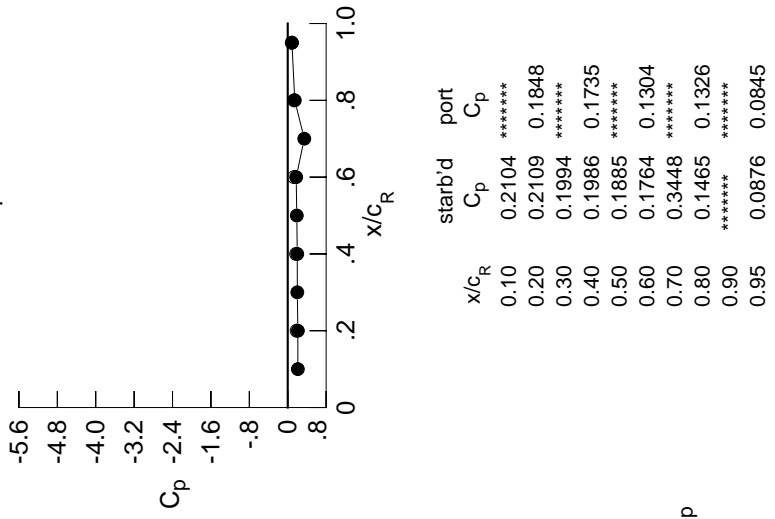

x/c_R	starb'd C_p	port C_p
0.10	0.2104	0.1848
0.20	0.2109	0.1848
0.30	0.1994	0.1735
0.40	0.1986	0.1735
0.50	0.1885	0.1735
0.60	0.1764	0.1304
0.70	0.3448	0.1326
0.80	0.1465	0.1326
0.90	0.0876	0.0845
0.95	0.0876	0.0845

Table D3. Continued.

η	$x/c_R = .2$		$x/c_R = .4$		$x/c_R = .6$		$x/c_R = .8$		$x/c_R = .95$	
	$C_{p,u}$	$C_{p,u}$	$C_{p,u}$	$C_{p,u}$	$C_{p,u}$	$C_{p,u}$	$C_{p,u}$	$C_{p,u}$	$C_{p,u}$	$C_{p,u}$
0.050	-0.0094	0.0063	0.1076	*****	*****	*****	*****	*****	*****	*****
0.100	-0.0044	0.0058	0.0983	*****	*****	*****	*****	*****	*****	*****
0.150	-0.0098	0.0060	0.0844	*****	*****	*****	*****	*****	*****	*****
0.200	-0.0108	0.0084	0.0730	*****	*****	*****	*****	*****	*****	*****
0.250	*****	0.0061	0.0595	-0.0905	-0.3156	*****	*****	*****	*****	*****
0.300	-0.0174	0.0044	0.0507	-0.0812	-0.3405	*****	*****	*****	*****	*****
0.350	*****	0.0035	0.0406	-0.0752	-0.3500	*****	*****	*****	*****	*****
0.400	-0.0330	0.0011	0.0368	-0.0630	-0.3660	*****	*****	*****	*****	*****
0.450	-0.0391	-0.0027	0.0459	-0.0622	-0.3707	*****	*****	*****	*****	*****
0.500	-0.0447	-0.0023	0.0193	-0.0587	-0.3758	*****	*****	*****	*****	*****
0.525	*****	-0.0059	0.0173	-0.0611	-0.3767	*****	*****	*****	*****	*****
0.550	-0.0469	-0.0130	0.0137	-0.0565	-0.3764	*****	*****	*****	*****	*****
0.575	*****	-0.0138	0.0218	-0.0584	-0.3808	*****	*****	*****	*****	*****
0.600	-0.0519	-0.0163	0.0059	-0.0605	-0.3791	*****	*****	*****	*****	*****
0.625	*****	*****	0.0109	-0.0578	-0.3767	*****	*****	*****	*****	*****
0.650	-0.0532	-0.0178	0.0035	-0.0583	-0.3740	*****	*****	*****	*****	*****
0.675	*****	-0.0276	-0.0043	-0.0609	-0.3613	*****	*****	*****	*****	*****
0.700	-0.0476	-0.0375	-0.0060	-0.0612	-0.3625	*****	*****	*****	*****	*****
0.725	*****	-0.0452	*****	-0.0605	-0.3556	*****	*****	*****	*****	*****
0.750	-0.0417	-0.0512	*****	-0.0627	-0.3511	*****	*****	*****	*****	*****
0.775	*****	-0.0557	-0.0264	-0.0693	-0.3415	*****	*****	*****	*****	*****
0.800	-0.0198	-0.0603	-0.0382	-0.0746	*****	*****	*****	*****	*****	*****
0.825	*****	-0.0586	-0.0492	-0.0707	-0.3695	*****	*****	*****	*****	*****
0.850	-0.0013	-0.0553	-0.0590	-0.0939	-0.3614	*****	*****	*****	*****	*****
0.875	*****	-0.0478	-0.0656	-0.1021	-0.4521	*****	*****	*****	*****	*****
0.900	0.0289	-0.0385	-0.0633	-0.1151	-0.5526	*****	*****	*****	*****	*****
0.925	*****	-0.0160	-0.0519	-0.1111	-0.9930	*****	*****	*****	*****	*****
0.950	0.0774	0.0190	-0.0232	-0.0861	-0.5083	*****	*****	*****	*****	*****
0.975	*****	0.0732	0.0326	-0.0260	-0.2581	*****	*****	*****	*****	*****
1.000	0.2168	0.2077	0.1963	0.1600	0.0955	*****	*****	*****	*****	*****
-0.200	$C_{p,l}$	$C_{p,l}$	$C_{p,l}$	$C_{p,l}$	$C_{p,l}$	$C_{p,l}$	$C_{p,l}$	$C_{p,l}$	$C_{p,l}$	$C_{p,l}$
-0.400	-0.0209	0.0008	0.0577	*****	-0.3446	*****	*****	*****	*****	*****
-0.600	-0.0464	0.0075	0.0222	-0.0802	-0.3683	*****	*****	*****	*****	*****
-0.700	-0.0674	-0.0218	-0.0030	-0.0682	-0.3814	*****	*****	*****	*****	*****
-0.800	-0.0688	-0.0579	-0.0203	-0.0736	-0.3899	*****	*****	*****	*****	*****
-0.850	-0.0525	*****	-0.0650	-0.0824	-0.3985	*****	*****	*****	*****	*****
-0.900	*****	-0.0792	-0.0932	-0.1131	-0.4586	*****	*****	*****	*****	*****
-0.950	*****	-0.0633	-0.1037	-0.1452	-0.5920	*****	*****	*****	*****	*****
-0.975	0.0461	-0.0228	-0.0680	-0.1354	-0.5065	*****	*****	*****	*****	*****
-1.000	0.1925	0.1853	0.1444	0.1535	0.0974	*****	*****	*****	*****	*****

Medium Radius L.E.
 Run No. = 30 , Point No. = 599
 $C_N = -0.012$, $C_m = 0.0002$
 $\alpha = -0.4^\circ$, $M_\infty = 0.597$
 $R_{mac} = 101.0 \times 10^6$

Leading Edge Pressures

● starboard
 ○ port

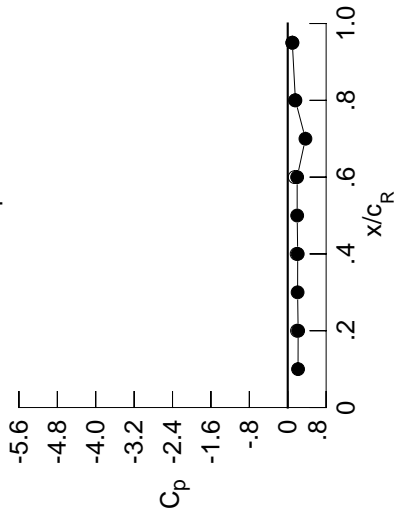

x/c_R	starb'd C_p	port C_p
0.10	0.2148	*****
0.20	0.2168	0.1925
0.30	0.2058	*****
0.40	0.2077	0.1853
0.50	0.1967	*****
0.60	0.1963	0.1444
0.70	0.3691	*****
0.80	0.1600	0.1535
0.90	*****	*****
0.95	0.0955	0.0974

Surface Pressures

● upper, starboard
 ○ lower, port

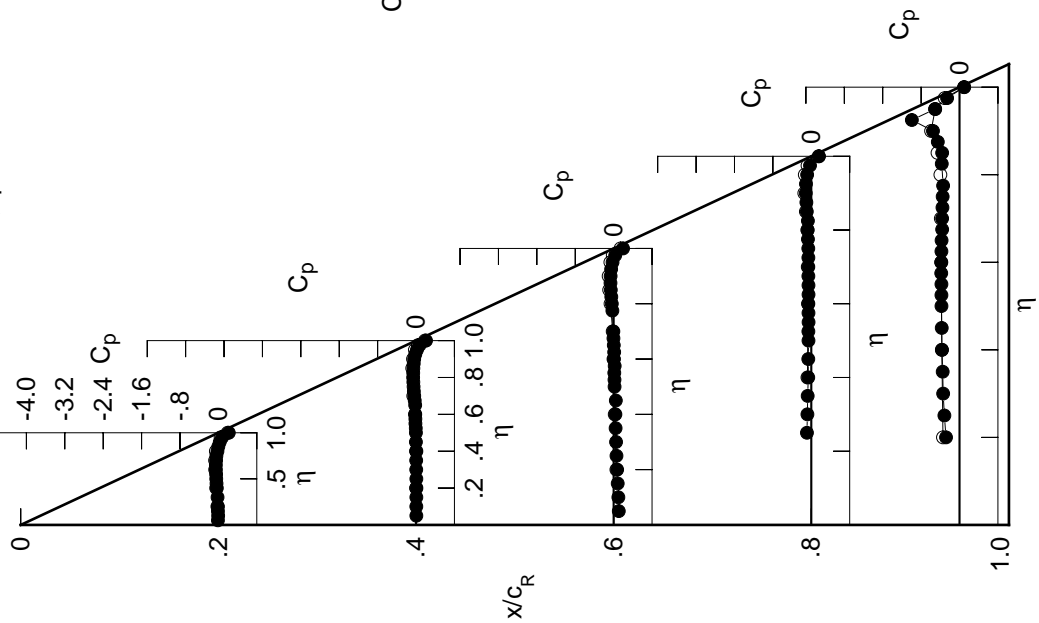

Table D3. Continued.

η	$x/c_R = .2$		$x/c_R = .4$		$x/c_R = .6$		$x/c_R = .8$		$x/c_R = .95$	
	$C_{p,u}$	$C_{p,u}$	$C_{p,u}$	$C_{p,u}$	$C_{p,u}$	$C_{p,u}$	$C_{p,u}$	$C_{p,u}$	$C_{p,u}$	$C_{p,u}$
0.050	-0.0296	-0.0101	0.0964	*****	*****	*****	*****	*****	*****	
0.100	-0.0250	-0.0100	0.0875	*****	*****	*****	*****	*****	*****	
0.150	-0.0303	-0.0103	0.0739	*****	*****	*****	*****	*****	*****	
0.200	-0.0311	-0.0080	0.0614	*****	*****	*****	*****	*****	-0.2773	
0.250	*****	-0.0105	0.0481	0.0983	-0.0983	-0.3091	*****	*****	*****	
0.300	-0.0382	-0.0131	0.0385	-0.0895	-0.3343	*****	*****	*****	*****	
0.350	*****	-0.0143	0.0284	-0.0837	-0.3437	*****	*****	*****	*****	
0.400	-0.0563	-0.0177	0.0235	-0.0716	-0.3596	*****	*****	*****	*****	
0.450	-0.0649	-0.0220	0.0322	-0.0709	-0.3646	*****	*****	*****	*****	
0.500	-0.0711	-0.0223	0.0049	-0.0684	-0.3704	*****	*****	*****	*****	
0.525	*****	-0.0261	0.0024	-0.0714	-0.3717	*****	*****	*****	*****	
0.550	-0.0750	-0.0345	-0.0024	-0.0679	-0.3713	*****	*****	*****	*****	
0.575	*****	-0.0359	0.0060	-0.0703	-0.3760	*****	*****	*****	*****	
0.600	-0.0826	-0.0398	-0.0113	-0.0718	-0.3743	*****	*****	*****	*****	
0.625	*****	*****	-0.0069	-0.0708	-0.3723	*****	*****	*****	*****	
0.650	-0.0864	-0.0428	-0.0148	-0.0727	-0.3687	*****	*****	*****	*****	
0.675	*****	-0.0543	-0.0239	-0.0758	-0.3567	*****	*****	*****	*****	
0.700	-0.0847	-0.0661	-0.0274	-0.0771	-0.3570	*****	*****	*****	*****	
0.725	*****	-0.0768	*****	-0.0781	-0.3492	*****	*****	*****	*****	
0.750	-0.0808	-0.0843	*****	-0.0817	-0.3425	*****	*****	*****	*****	
0.775	*****	-0.0915	-0.0536	-0.0898	-0.3313	*****	*****	*****	*****	
0.800	-0.0619	-0.0994	-0.0689	-0.0975	*****	*****	*****	*****	*****	
0.825	*****	-0.1014	-0.0842	-0.0949	-0.3620	*****	*****	*****	*****	
0.850	-0.0459	-0.1015	-0.0984	-0.1233	-0.3559	*****	*****	*****	*****	
0.875	*****	-0.0991	-0.1108	-0.1377	-0.4525	*****	*****	*****	*****	
0.900	-0.0191	-0.0922	-0.1137	-0.1582	-0.5615	*****	*****	*****	*****	
0.925	*****	-0.0753	-0.1095	-0.1628	-1.0422	*****	*****	*****	*****	
0.950	0.0243	-0.0443	-0.0882	-0.1468	-0.5466	*****	*****	*****	*****	
0.975	*****	0.0042	-0.0400	-0.0977	-0.3061	*****	*****	*****	*****	
1.000	0.2082	0.1937	0.1853	0.1484	0.0959	*****	*****	*****	*****	
-0.200	$C_{p,l}$	$C_{p,l}$	$C_{p,l}$	$C_{p,l}$	$C_{p,l}$	$C_{p,l}$	$C_{p,l}$	$C_{p,l}$	$C_{p,l}$	
-0.400	-0.0018	0.0156	0.0681	*****	*****	-0.3537	*****	*****	*****	
-0.600	-0.0236	0.0235	0.0340	-0.0725	-0.3779	*****	*****	*****	*****	
-0.700	-0.0373	-0.0009	0.0124	-0.0583	-0.3915	*****	*****	*****	*****	
-0.800	-0.0335	-0.0294	-0.0008	-0.0594	-0.4000	*****	*****	*****	*****	
-0.850	-0.0115	*****	-0.0355	-0.0632	-0.4088	*****	*****	*****	*****	
-0.900	*****	-0.0351	-0.0554	-0.0846	-0.4668	*****	*****	*****	*****	
-0.950	*****	-0.0112	-0.0550	-0.1042	-0.5850	*****	*****	*****	*****	
-0.975	0.0958	0.0356	-0.0071	-0.0770	-0.4630	*****	*****	*****	*****	
-1.000	*****	0.0990	0.0483	-0.0124	-0.2533	*****	*****	*****	*****	
	0.1886	0.1811	0.1397	0.1565	0.1036	*****	*****	*****	*****	

Medium Radius L.E.
 Run No. = 30 , Point No. = 600
 $C_N = 0.025$, $C_m = -0.0049$
 $\alpha = 0.7^\circ$, $M_\infty = 0.601$
 $R_{mac} = 101.3 \times 10^6$

Leading Edge Pressures

● starboard
 ○ port

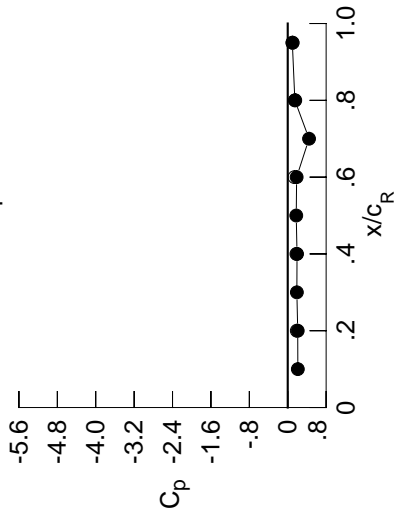

x/c_R	starb'd C_p	port C_p
0.10	0.2107	*****
0.20	0.2082	0.1886
0.30	0.1902	*****
0.40	0.1937	0.1811
0.50	0.1773	*****
0.60	0.1853	0.1397
0.70	0.4444	*****
0.80	0.1484	0.1565
0.90	*****	*****
0.95	0.0959	0.1036

Surface Pressures
 ● upper, starboard
 ○ lower, port

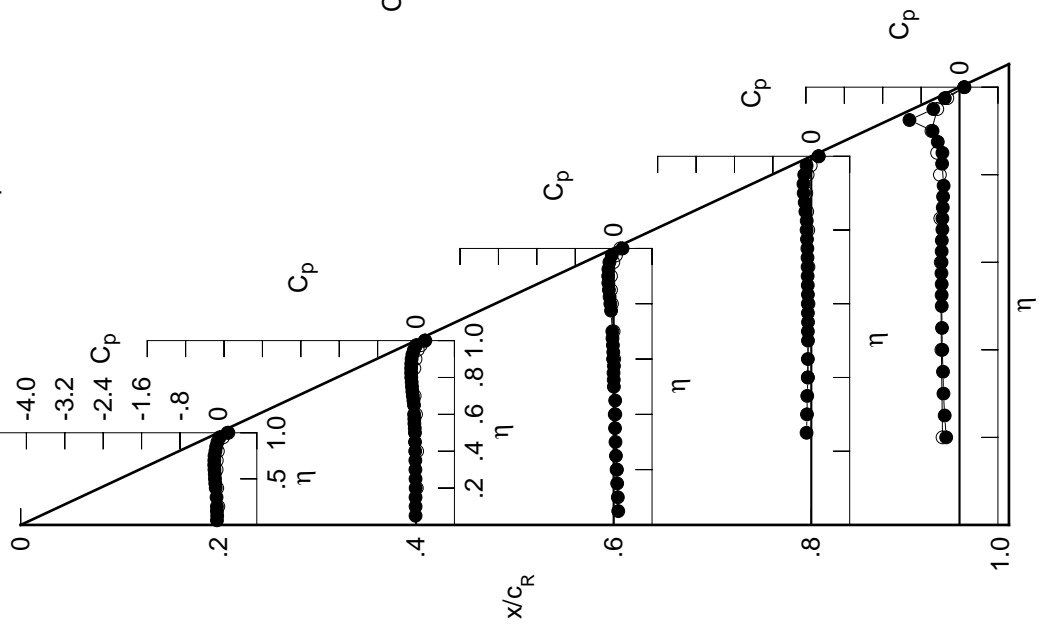
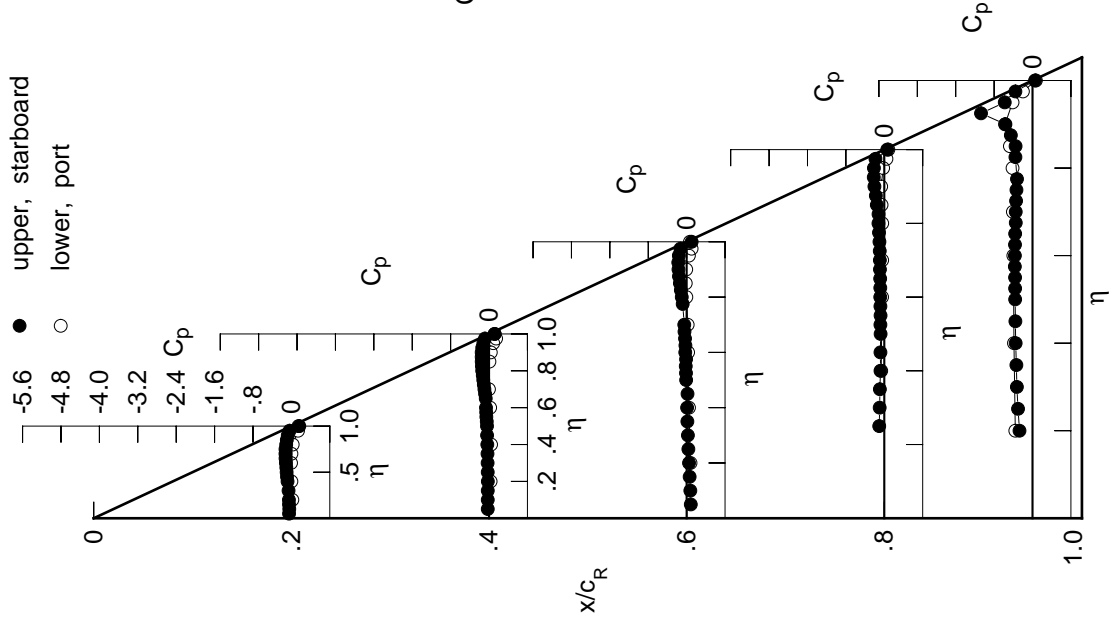

Table D3. Continued.

η	x/c_R .2	x/c_R .4	x/c_R .6	x/c_R .8	x/c_R .95
	$C_{p,u}$	$C_{p,u}$	$C_{p,u}$	$C_{p,u}$	$C_{p,u}$
0.050	-0.0487	-0.0263	0.0861	*****	*****
0.100	-0.0444	-0.0267	0.0767	*****	*****
0.150	-0.0494	-0.0268	0.0627	*****	*****
0.200	-0.0515	-0.0249	0.0499	*****	-0.2710
0.250	*****	-0.0271	0.0364	-0.1059	-0.3018
0.300	-0.0591	-0.0298	0.0265	-0.0958	-0.3260
0.350	*****	-0.0320	0.0155	-0.0917	-0.3361
0.400	-0.0798	-0.0357	0.0093	-0.0791	-0.3510
0.450	-0.0908	-0.0410	0.0183	-0.0802	-0.3564
0.500	-0.0989	-0.0425	-0.0101	-0.0772	-0.3619
0.525	*****	-0.0475	-0.0140	-0.0812	-0.3627
0.550	-0.1055	-0.0557	-0.0185	-0.0776	-0.3634
0.575	*****	-0.0589	-0.0119	-0.0805	-0.3678
0.600	-0.1147	-0.0634	-0.0286	-0.0839	-0.3671
0.625	*****	*****	-0.0258	-0.0831	-0.3644
0.650	-0.1223	-0.0686	-0.0340	-0.0857	-0.3614
0.675	*****	-0.0825	-0.0451	-0.0904	-0.3492
0.700	-0.1236	-0.0961	-0.0493	-0.0922	-0.3495
0.725	*****	-0.1090	*****	-0.0944	-0.3423
0.750	-0.1228	-0.1204	*****	-0.1010	-0.3340
0.775	*****	-0.1302	-0.0826	-0.1102	-0.3231
0.800	-0.1079	-0.1421	-0.1012	-0.1218	*****
0.825	*****	-0.1479	-0.1206	-0.1200	-0.3563
0.850	-0.0956	-0.1528	-0.1411	-0.1551	-0.3525
0.875	*****	-0.1537	-0.1599	-0.1759	-0.4509
0.900	-0.0757	-0.1540	-0.1704	-0.2052	-0.5639
0.925	*****	-0.1419	-0.1745	-0.2191	-1.0725
0.950	-0.0372	-0.1187	-0.1627	-0.2161	-0.5788
0.975	*****	-0.0846	-0.1296	-0.1840	-0.3564
1.000	0.1648	0.1170	0.1052	0.0620	0.0527
	$C_{p,l}$	$C_{p,l}$	$C_{p,l}$	$C_{p,l}$	$C_{p,l}$
-0.200	0.0198	0.0331	0.0807	*****	-0.3584
-0.400	-0.0003	0.0427	0.0484	-0.0643	-0.3865
-0.600	-0.0070	0.0228	0.0300	-0.0461	-0.3990
-0.700	0.0004	-0.0013	0.0215	-0.0444	-0.4085
-0.800	0.0275	*****	-0.0061	-0.0434	-0.4163
-0.850	*****	0.0079	-0.0180	-0.0564	-0.4712
-0.900	*****	0.0370	-0.0090	-0.0645	-0.5723
-0.950	0.1382	0.0870	0.0472	-0.0239	-0.4162
-0.975	*****	0.1470	0.1034	0.0451	-0.1997
-1.000	0.1483	0.1166	0.0686	0.0839	0.0705

Surface Pressures



Medium Radius L.E.
 Run No. = 30, Point No. = 601
 $C_N = 0.060$, $C_m = -0.0078$
 $\alpha = 1.8^\circ$, $M_\infty = 0.601$
 $R_{mac} = 101.5 \times 10^6$

Leading Edge Pressures

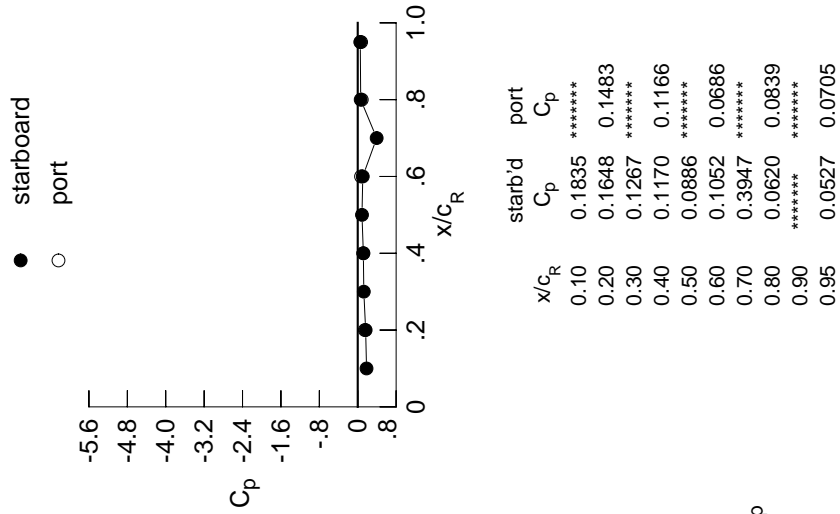

x/c_R	starb'd C_p	port C_p
0.10	0.1835	*****
0.20	0.1648	0.1483
0.30	0.1267	*****
0.40	0.1170	0.1166
0.50	0.0886	*****
0.60	0.1052	0.0686
0.70	0.3947	*****
0.80	0.0620	0.0839
0.90	*****	*****
0.95	0.0527	0.0705

Table D3. Continued.

η	$x/c_R = .2$		$x/c_R = .4$		$x/c_R = .6$		$x/c_R = .8$		$x/c_R = .95$	
	$C_{p,u}$	$C_{p,l}$	$C_{p,u}$	$C_{p,l}$	$C_{p,u}$	$C_{p,l}$	$C_{p,u}$	$C_{p,l}$	$C_{p,u}$	$C_{p,l}$
0.050	-0.0686	-0.0410	0.0758	*****	*****	*****	*****	*****	*****	*****
0.100	-0.0646	-0.0417	0.0666	*****	*****	*****	*****	*****	*****	*****
0.150	-0.0692	-0.0421	0.0522	*****	*****	*****	*****	*****	*****	*****
0.200	-0.0706	-0.0397	0.0395	*****	*****	*****	*****	*****	*****	*****
0.250	*****	-0.0425	0.0241	-0.1126	-0.1126	-0.1126	-0.1126	-0.1126	-0.1126	-0.1126
0.300	-0.0805	-0.0464	0.0150	-0.1040	-0.1040	-0.1040	-0.1040	-0.1040	-0.1040	-0.1040
0.350	*****	-0.0486	0.0031	-0.0979	-0.0979	-0.0979	-0.0979	-0.0979	-0.0979	-0.0979
0.400	-0.1034	-0.0534	-0.0035	-0.0879	-0.0879	-0.0879	-0.0879	-0.0879	-0.0879	-0.0879
0.450	-0.1155	-0.0591	0.0041	-0.0881	-0.0881	-0.0881	-0.0881	-0.0881	-0.0881	-0.0881
0.500	-0.1253	-0.0625	-0.0248	-0.0872	-0.0872	-0.0872	-0.0872	-0.0872	-0.0872	-0.0872
0.525	*****	-0.0675	-0.0285	-0.0902	-0.0902	-0.0902	-0.0902	-0.0902	-0.0902	-0.0902
0.550	-0.1343	-0.0768	-0.0349	-0.0881	-0.0881	-0.0881	-0.0881	-0.0881	-0.0881	-0.0881
0.575	*****	-0.0807	-0.0275	-0.0918	-0.0918	-0.0918	-0.0918	-0.0918	-0.0918	-0.0918
0.600	-0.1464	-0.0864	-0.0460	-0.0951	-0.0951	-0.0951	-0.0951	-0.0951	-0.0951	-0.0951
0.625	*****	*****	-0.0437	-0.0958	-0.0958	-0.0958	-0.0958	-0.0958	-0.0958	-0.0958
0.650	-0.1569	-0.0942	-0.0525	-0.0986	-0.0986	-0.0986	-0.0986	-0.0986	-0.0986	-0.0986
0.675	*****	-0.1100	-0.0648	-0.1038	-0.1038	-0.1038	-0.1038	-0.1038	-0.1038	-0.1038
0.700	-0.1624	-0.1260	-0.0715	-0.1078	-0.1078	-0.1078	-0.1078	-0.1078	-0.1078	-0.1078
0.725	*****	-0.1413	*****	-0.1105	-0.1105	-0.1105	-0.1105	-0.1105	-0.1105	-0.1105
0.750	-0.1646	-0.1552	*****	-0.1189	-0.1189	-0.1189	-0.1189	-0.1189	-0.1189	-0.1189
0.775	*****	-0.1692	-0.1112	-0.1304	-0.1304	-0.1304	-0.1304	-0.1304	-0.1304	-0.1304
0.800	-0.1548	-0.1851	-0.1335	-0.1447	-0.1447	-0.1447	-0.1447	-0.1447	-0.1447	-0.1447
0.825	*****	-0.1954	-0.1580	-0.1452	-0.1452	-0.1452	-0.1452	-0.1452	-0.1452	-0.1452
0.850	-0.1475	-0.2050	-0.1837	-0.1862	-0.1862	-0.1862	-0.1862	-0.1862	-0.1862	-0.1862
0.875	*****	-0.2118	-0.2098	-0.2146	-0.2146	-0.2146	-0.2146	-0.2146	-0.2146	-0.2146
0.900	-0.1336	-0.2170	-0.2294	-0.2530	-0.2530	-0.2530	-0.2530	-0.2530	-0.2530	-0.2530
0.925	*****	-0.2130	-0.2430	-0.2780	-0.2780	-0.2780	-0.2780	-0.2780	-0.2780	-0.2780
0.950	-0.1059	-0.1990	-0.2444	-0.2887	-0.2887	-0.2887	-0.2887	-0.2887	-0.2887	-0.2887
0.975	*****	-0.1822	-0.2303	-0.2798	-0.4151	-0.4151	-0.4151	-0.4151	-0.4151	-0.4151
1.000	0.0838	-0.0050	-0.0269	-0.0902	-0.0902	-0.0902	-0.0902	-0.0902	-0.0902	-0.0902
-0.200	$C_{p,l}$	$C_{p,l}$	$C_{p,l}$	$C_{p,l}$	$C_{p,l}$	$C_{p,l}$	$C_{p,l}$	$C_{p,l}$	$C_{p,l}$	$C_{p,l}$
-0.400	0.0401	0.0494	0.0929	*****	*****	*****	*****	*****	*****	*****
-0.600	0.0225	0.0604	0.0624	-0.0545	-0.0545	-0.0545	-0.0545	-0.0545	-0.0545	-0.0545
-0.700	0.0213	0.0441	0.0469	-0.0341	-0.0341	-0.0341	-0.0341	-0.0341	-0.0341	-0.0341
-0.800	0.0323	0.0246	0.0412	-0.0302	-0.0302	-0.0302	-0.0302	-0.0302	-0.0302	-0.0302
-0.850	0.0624	*****	0.0204	-0.0232	-0.0232	-0.0232	-0.0232	-0.0232	-0.0232	-0.0232
-0.900	*****	0.0456	0.0147	-0.0317	-0.0317	-0.0317	-0.0317	-0.0317	-0.0317	-0.0317
-0.950	*****	0.0786	0.0311	-0.0296	-0.0296	-0.0296	-0.0296	-0.0296	-0.0296	-0.0296
-0.975	0.1706	0.1269	0.0905	0.0203	-0.3758	-0.3758	-0.3758	-0.3758	-0.3758	-0.3758
-1.000	0.0743	0.0052	-0.0756	-0.0561	-0.0561	-0.0561	-0.0561	-0.0561	-0.0561	-0.0561

Medium Radius L.E.
 Run No. = 30 , Point No. = 602
 $C_N = 0.097$, $C_m = -0.0128$
 $\alpha = 2.8^\circ$, $M_\infty = 0.601$
 $R_{mac} = 101.3 \times 10^6$

Leading Edge Pressures

● starboard
 ○ port

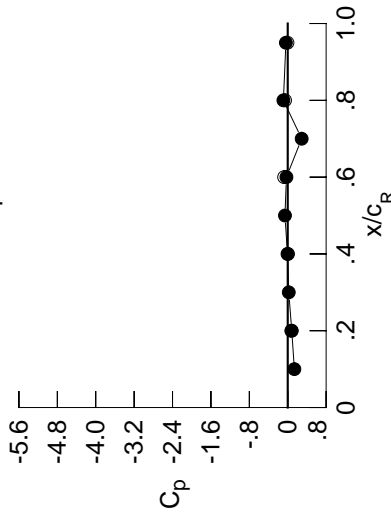

x/c_R	starb'd C_p	port C_p
0.10	0.1382	*****
0.20	0.0838	0.0743
0.30	0.0216	*****
0.40	-0.0050	0.0052
0.50	-0.0579	*****
0.60	-0.0269	-0.0756
0.70	0.2902	*****
0.80	-0.0902	-0.0561
0.90	*****	*****
0.95	-0.0380	-0.0057

Surface Pressures
 ● upper, starboard
 ○ lower, port

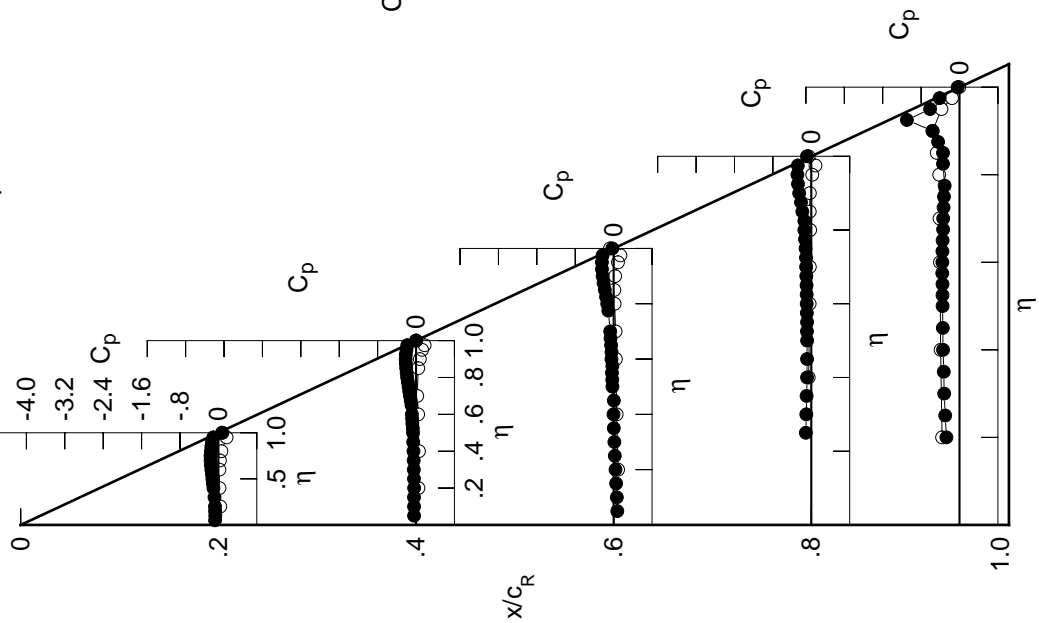

Table D3. Continued.

η	$x/c_R = .2$		$x/c_R = .4$		$x/c_R = .6$		$x/c_R = .8$		$x/c_R = .95$	
	$C_{p,u}$	$C_{p,u}$	$C_{p,u}$	$C_{p,u}$	$C_{p,u}$	$C_{p,u}$	$C_{p,u}$	$C_{p,u}$	$C_{p,u}$	$C_{p,u}$
0.050	-0.1024	-0.0675	0.0574	*****	*****	*****	*****	*****	*****	
0.100	-0.0989	-0.0683	0.0484	*****	*****	*****	*****	*****	*****	
0.150	-0.1045	-0.0702	0.0332	*****	*****	*****	*****	*****	*****	
0.200	-0.1067	-0.0690	0.0207	*****	*****	*****	*****	*****	-0.2726	
0.250	*****	-0.0718	0.0043	-0.1231	-0.1231	-0.1231	-0.1231	-0.1231	-0.2866	
0.300	-0.1186	-0.0771	-0.0058	-0.1150	-0.1150	-0.1150	-0.1150	-0.1150	-0.3027	
0.350	*****	-0.0802	-0.0189	-0.1099	-0.1099	-0.1099	-0.1099	-0.1099	-0.3097	
0.400	-0.1463	-0.0862	-0.0274	-0.1001	-0.1001	-0.1001	-0.1001	-0.1001	-0.3237	
0.450	-0.1624	-0.0937	-0.0208	-0.1018	-0.1018	-0.1018	-0.1018	-0.1018	-0.3285	
0.500	-0.1762	-0.0993	-0.0519	-0.1015	-0.1015	-0.1015	-0.1015	-0.1015	-0.3334	
0.525	*****	-0.1067	-0.0562	-0.1067	-0.1067	-0.1067	-0.1067	-0.1067	-0.3346	
0.550	-0.1898	-0.1170	-0.0635	-0.1054	-0.1054	-0.1054	-0.1054	-0.1054	-0.3348	
0.575	*****	-0.1239	-0.0585	-0.1101	-0.1101	-0.1101	-0.1101	-0.1101	-0.3391	
0.600	-0.2079	-0.1309	-0.0783	-0.1147	-0.1147	-0.1147	-0.1147	-0.1147	-0.3381	
0.625	*****	*****	-0.0785	-0.1179	-0.1179	-0.1179	-0.1179	-0.1179	-0.3353	
0.650	-0.2256	-0.1438	-0.0887	-0.1224	-0.1224	-0.1224	-0.1224	-0.1224	-0.3318	
0.675	*****	-0.1630	-0.1041	-0.1306	-0.1306	-0.1306	-0.1306	-0.1306	-0.3195	
0.700	-0.2393	-0.1841	-0.1127	-0.1357	-0.1357	-0.1357	-0.1357	-0.1357	-0.3173	
0.725	*****	-0.2049	*****	-0.1434	-0.1434	-0.1434	-0.1434	-0.1434	-0.3055	
0.750	-0.2514	-0.2255	*****	-0.1543	-0.1543	-0.1543	-0.1543	-0.1543	-0.2905	
0.775	*****	-0.2474	-0.1675	-0.1714	-0.1714	-0.1714	-0.1714	-0.1714	-0.2688	
0.800	-0.2519	-0.2712	-0.1981	-0.1906	-0.1906	-0.1906	-0.1906	-0.1906	*****	
0.825	*****	-0.2922	-0.2333	-0.1952	-0.1952	-0.1952	-0.1952	-0.1952	-0.2971	
0.850	-0.2577	-0.3122	-0.2727	-0.2476	-0.2476	-0.2476	-0.2476	-0.2476	-0.3097	
0.875	*****	-0.3326	-0.3145	-0.2927	-0.2927	-0.2927	-0.2927	-0.2927	-0.4217	
0.900	-0.2621	-0.3537	-0.3543	-0.3513	-0.3513	-0.3513	-0.3513	-0.3513	-0.5565	
0.925	*****	-0.3702	-0.3917	-0.4040	-0.4040	-0.4040	-0.4040	-0.4040	-1.1279	
0.950	-0.2656	-0.3840	-0.4284	-0.4502	-0.4502	-0.4502	-0.4502	-0.4502	-0.6961	
0.975	*****	-0.4176	-0.4696	-0.5007	-0.5007	-0.5007	-0.5007	-0.5007	-0.5567	
1.000	-0.1665	-0.3984	-0.4696	-0.6124	-0.6124	-0.6124	-0.6124	-0.6124	-0.3613	
	$C_{p,l}$	$C_{p,l}$	$C_{p,l}$	$C_{p,l}$	$C_{p,l}$	$C_{p,l}$	$C_{p,l}$	$C_{p,l}$	$C_{p,l}$	
-0.200	0.0832	0.0851	0.1201	*****	*****	*****	*****	*****	-0.3629	
-0.400	0.0707	0.0979	0.0923	-0.0340	-0.0340	-0.0340	-0.0340	-0.0340	-0.4044	
-0.600	0.0787	0.0883	0.0822	-0.0086	-0.0086	-0.0086	-0.0086	-0.0086	-0.4206	
-0.700	0.0954	0.0773	0.0822	-0.0004	-0.0004	-0.0004	-0.0004	-0.0004	-0.4292	
-0.800	0.1279	*****	0.0728	0.0165	0.0165	0.0165	0.0165	0.0165	-0.4325	
-0.850	*****	0.1154	0.0774	0.0179	0.0179	0.0179	0.0179	0.0179	-0.4735	
-0.900	*****	0.1498	0.1016	0.0341	0.0341	0.0341	0.0341	0.0341	-0.5315	
-0.950	0.2152	0.1866	0.1571	0.0917	0.0917	0.0917	0.0917	0.0917	-0.3041	
-0.975	*****	0.2049	0.1836	0.1426	0.1426	0.1426	0.1426	0.1426	-0.0888	
-1.000	-0.1817	-0.3743	-0.5907	-0.5507	-0.5507	-0.5507	-0.5507	-0.5507	-0.2950	

Medium Radius L.E.
 Run No. = 30 , Point No. = 604
 $C_N = 0.169$, $C_m = -0.0211$
 $\alpha = 4.9^\circ$, $M_\infty = 0.601$
 $R_{mac} = 101.3 \times 10^6$

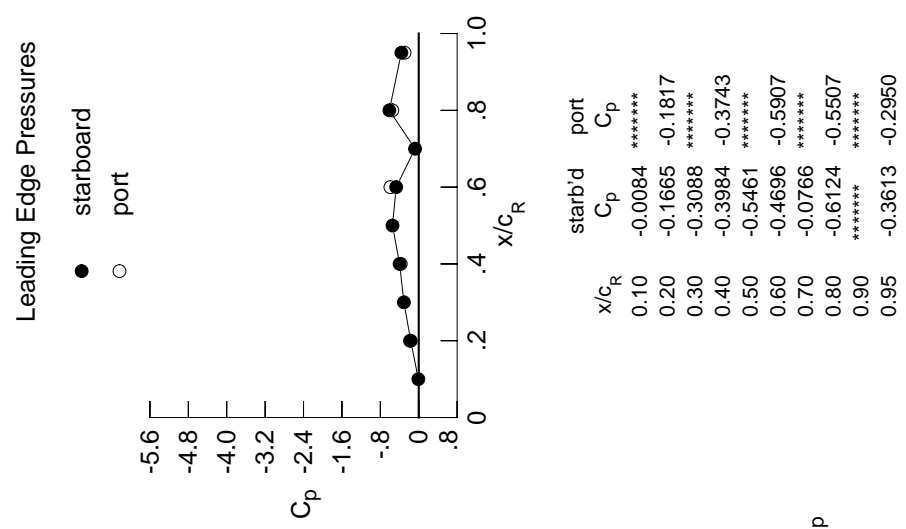
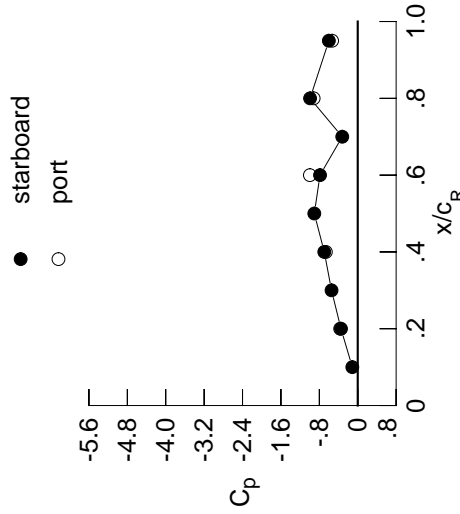

Table D3. Continued.

η	$x/c_R = .2$		$x/c_R = .4$		$x/c_R = .6$		$x/c_R = .8$		$x/c_R = .95$	
	$C_{p,u}$	$C_{p,l}$	$C_{p,u}$	$C_{p,l}$	$C_{p,u}$	$C_{p,l}$	$C_{p,u}$	$C_{p,l}$	$C_{p,u}$	$C_{p,l}$
0.050	-0.1202	-0.0807	0.0488	*****	*****	*****	*****	*****	*****	
0.100	-0.1181	-0.0821	0.0397	*****	*****	*****	*****	*****	*****	
0.150	-0.1231	-0.0844	0.0240	*****	*****	*****	*****	*****	*****	
0.200	-0.1266	-0.0828	0.0112	*****	*****	*****	*****	*****	-0.2741	
0.250	*****	-0.0872	-0.0058	-0.1280	-0.1280	-0.2823	*****	*****	*****	
0.300	-0.1386	-0.0924	-0.0151	-0.1203	-0.1203	-0.2955	*****	*****	*****	
0.350	*****	-0.0970	-0.0296	-0.1152	-0.1152	-0.2998	*****	*****	*****	
0.400	-0.1697	-0.1033	-0.0385	-0.1066	-0.1066	-0.3148	*****	*****	*****	
0.450	-0.1867	-0.1127	-0.0337	-0.1090	-0.1090	-0.3189	*****	*****	*****	
0.500	-0.2031	-0.1194	-0.0647	-0.1101	-0.1101	-0.3246	*****	*****	*****	
0.525	*****	-0.1271	-0.0710	-0.1150	-0.1150	-0.3248	*****	*****	*****	
0.550	-0.2195	-0.1391	-0.0787	-0.1145	-0.1145	-0.3252	*****	*****	*****	
0.575	*****	-0.1463	-0.0745	-0.1197	-0.1197	-0.3292	*****	*****	*****	
0.600	-0.2411	-0.1552	-0.0955	-0.1250	-0.1250	-0.3280	*****	*****	*****	
0.625	*****	*****	-0.0967	-0.1293	-0.1293	-0.3247	*****	*****	*****	
0.650	-0.2630	-0.1708	-0.1080	-0.1352	-0.1352	-0.3210	*****	*****	*****	
0.675	*****	-0.1920	-0.1251	-0.1432	-0.1432	-0.3091	*****	*****	*****	
0.700	-0.2815	-0.2157	-0.1359	-0.1514	-0.1514	-0.3055	*****	*****	*****	
0.725	*****	-0.2395	*****	-0.1599	-0.1599	-0.2933	*****	*****	*****	
0.750	-0.2989	-0.2642	*****	-0.1735	-0.1735	-0.2744	*****	*****	*****	
0.775	*****	-0.2902	-0.1989	-0.1926	-0.1926	-0.2457	*****	*****	*****	
0.800	-0.3069	-0.3195	-0.2336	-0.2153	*****	*****	*****	*****	*****	
0.825	*****	-0.3461	-0.2747	-0.2226	-0.2226	-0.2644	*****	*****	*****	
0.850	-0.3198	-0.3734	-0.3213	-0.2814	-0.2814	-0.2858	*****	*****	*****	
0.875	*****	-0.4018	-0.3736	-0.3350	-0.4014	*****	*****	*****	*****	
0.900	-0.3372	-0.4320	-0.4246	-0.4052	-0.4052	-0.5455	*****	*****	*****	
0.925	*****	-0.4631	-0.4770	-0.4749	-1.1249	*****	*****	*****	*****	
0.950	-0.3612	-0.4937	-0.5358	-0.5423	-0.7382	*****	*****	*****	*****	
0.975	*****	-0.5636	-0.6162	-0.6335	-0.6381	*****	*****	*****	*****	
1.000	-0.3492	-0.6967	-0.7859	-0.9927	-0.6013	*****	*****	*****	*****	
-0.200	$C_{p,l}$	$C_{p,l}$	$C_{p,l}$	$C_{p,l}$	$C_{p,l}$	$C_{p,l}$	$C_{p,l}$	$C_{p,l}$	$C_{p,l}$	
-0.400	0.1058	0.1048	0.1341	*****	*****	-0.3627	*****	*****	*****	
-0.600	0.0949	0.1184	0.1085	-0.0232	-0.4100	*****	*****	*****	*****	
-0.700	0.1066	0.1114	0.1001	0.0045	-0.4284	*****	*****	*****	*****	
-0.800	0.1253	0.1030	0.1029	0.0155	-0.4371	*****	*****	*****	*****	
-0.850	0.1573	*****	0.0975	0.0356	-0.4381	*****	*****	*****	*****	
-0.900	*****	0.1462	0.1056	0.0407	-0.4738	*****	*****	*****	*****	
-0.950	0.2262	0.2041	0.1786	0.1315	0.0619	-0.5181	*****	*****	*****	
-0.975	0.2262	0.2041	0.1793	0.1186	-0.2721	*****	*****	*****	*****	
-1.000	0.2012	0.1866	0.1543	-0.0621	*****	*****	*****	*****	*****	
-1.000	-0.3653	-0.6643	-0.9967	-0.9185	-0.5338	*****	*****	*****	*****	

Medium Radius L.E.
 Run No. = 30 , Point No. = 605
 $C_N = 0.207$, $C_m = -0.0255$
 $\alpha = 6.0^\circ$, $M_\infty = 0.601$
 $R_{mac} = 101.2 \times 10^6$

Leading Edge Pressures



x/c_R	starb'd C_p	port C_p
0.10	-0.1124	*****
0.20	-0.3492	-0.3653
0.30	-0.5459	*****
0.40	-0.6967	-0.6643
0.50	-0.9048	*****
0.60	-0.7859	-0.9967
0.70	-0.3228	*****
0.80	-0.9927	-0.9185
0.90	*****	*****
0.95	-0.6013	-0.5338

Surface Pressures

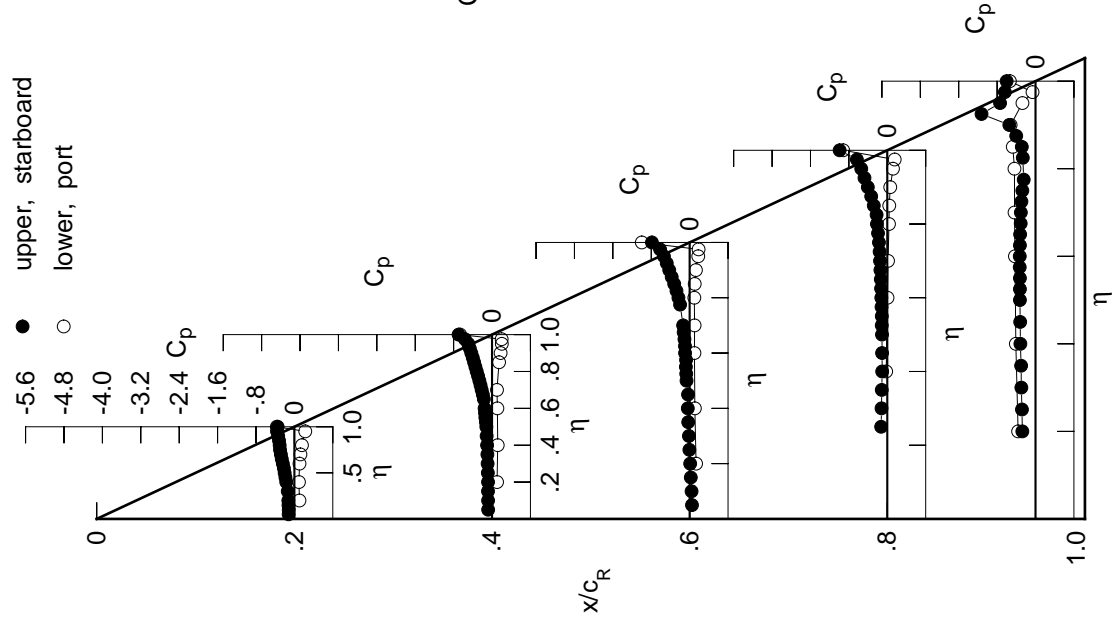
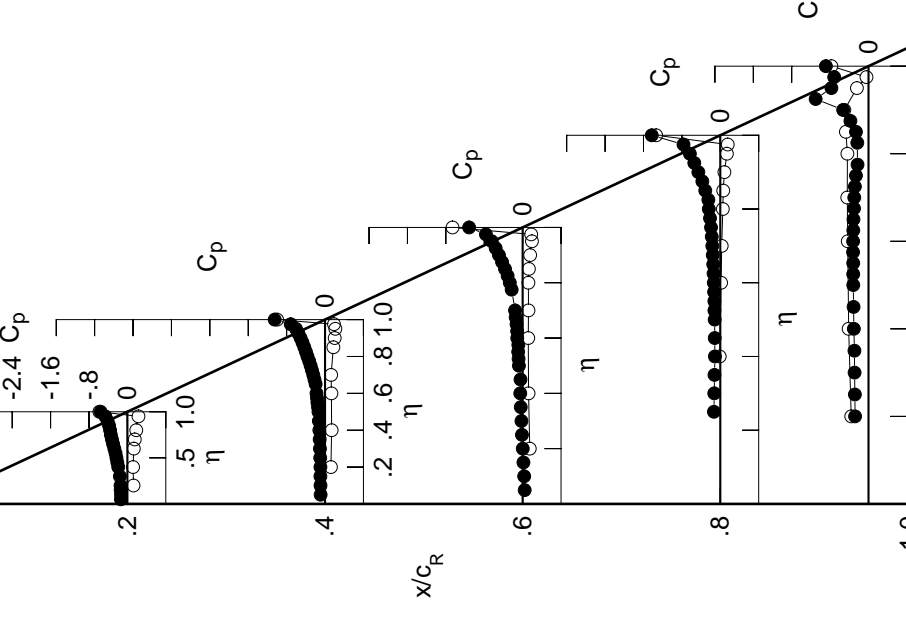
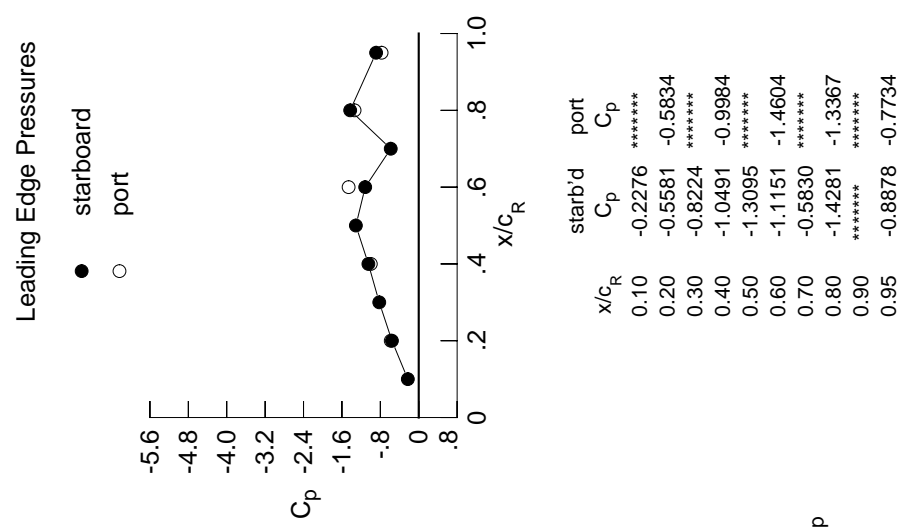

Table D3. Continued.

η	$x/c_R = .2$		$x/c_R = .4$		$x/c_R = .6$		$x/c_R = .8$		$x/c_R = .95$	
	$C_{p,u}$	$C_{p,u}$	$C_{p,u}$	$C_{p,u}$	$C_{p,u}$	$C_{p,u}$	$C_{p,u}$	$C_{p,u}$	$C_{p,u}$	$C_{p,u}$
0.050	-0.1349	-0.0921	0.0421	*****	*****	*****	*****	*****	*****	
0.100	-0.1338	-0.0942	0.0320	*****	*****	*****	*****	*****	*****	
0.150	-0.1399	-0.0969	0.0165	*****	*****	*****	*****	*****	*****	
0.200	-0.1436	-0.0960	0.0027	*****	*****	*****	*****	*****	-0.2803	
0.250	*****	-0.1007	-0.0143	-0.1331	-0.2837	*****	*****	*****	*****	
0.300	-0.1566	-0.1065	-0.0249	-0.1252	-0.2906	*****	*****	*****	*****	
0.350	*****	-0.1116	-0.0391	-0.1207	-0.2924	*****	*****	*****	*****	
0.400	-0.1904	-0.1188	-0.0495	-0.1122	-0.3057	*****	*****	*****	*****	
0.450	-0.2094	-0.1291	-0.0449	-0.1159	-0.3110	*****	*****	*****	*****	
0.500	-0.2282	-0.1371	-0.0780	-0.1168	-0.3178	*****	*****	*****	*****	
0.525	*****	-0.1458	-0.0848	-0.1223	-0.3183	*****	*****	*****	*****	
0.550	-0.2475	-0.1590	-0.0929	-0.1228	-0.3186	*****	*****	*****	*****	
0.575	*****	-0.1673	-0.0899	-0.1289	-0.3216	*****	*****	*****	*****	
0.600	-0.2723	-0.1774	-0.1120	-0.1354	-0.3207	*****	*****	*****	*****	
0.625	*****	*****	-0.1145	-0.1402	-0.3168	*****	*****	*****	*****	
0.650	-0.2979	-0.1960	-0.1269	-0.1474	-0.3133	*****	*****	*****	*****	
0.675	*****	-0.2203	-0.1450	-0.1568	-0.3014	*****	*****	*****	*****	
0.700	-0.3215	-0.2449	-0.1582	-0.1664	-0.2970	*****	*****	*****	*****	
0.725	*****	-0.2724	*****	-0.1773	-0.2840	*****	*****	*****	*****	
0.750	-0.3449	-0.2998	*****	-0.1930	-0.2612	*****	*****	*****	*****	
0.775	*****	-0.3303	-0.2290	-0.2144	-0.2289	*****	*****	*****	*****	
0.800	-0.3600	-0.3653	-0.2671	-0.2394	*****	*****	*****	*****	*****	
0.825	*****	-0.3976	-0.3126	-0.2490	-0.2338	*****	*****	*****	*****	
0.850	-0.3817	-0.4321	-0.3673	-0.3127	-0.2616	*****	*****	*****	*****	
0.875	*****	-0.4692	-0.4288	-0.3732	-0.3770	*****	*****	*****	*****	
0.900	-0.4118	-0.5100	-0.4932	-0.4570	-0.5279	*****	*****	*****	*****	
0.925	*****	-0.5548	-0.5615	-0.5415	-1.1015	*****	*****	*****	*****	
0.950	-0.4594	-0.6048	-0.6432	-0.6337	-0.7731	*****	*****	*****	*****	
0.975	*****	-0.7148	-0.7658	-0.7664	-0.7149	*****	*****	*****	*****	
1.000	-0.5581	-1.0491	-1.1151	-1.4281	-0.8878	*****	*****	*****	*****	
-0.200	$C_{p,l}$	$C_{p,l}$	$C_{p,l}$	$C_{p,l}$	$C_{p,l}$	$C_{p,l}$	$C_{p,l}$	$C_{p,l}$	$C_{p,l}$	
-0.400	0.1278	0.1229	0.1486	*****	-0.3604	*****	*****	*****	*****	
-0.600	0.1186	0.1372	0.1233	-0.0117	-0.4135	*****	*****	*****	*****	
-0.700	0.1336	0.1328	0.1171	0.0168	-0.4328	*****	*****	*****	*****	
-0.800	0.1534	0.1270	0.1216	0.0297	-0.4424	*****	*****	*****	*****	
-0.850	0.1846	*****	0.1198	0.0531	-0.4403	*****	*****	*****	*****	
-0.900	*****	0.1736	0.1304	0.0614	-0.4716	*****	*****	*****	*****	
-0.950	*****	0.2018	0.1560	0.0857	-0.5029	*****	*****	*****	*****	
-0.975	0.2307	0.2144	0.1932	0.1374	-0.2417	*****	*****	*****	*****	
-1.000	*****	0.1866	0.1778	0.1555	-0.0424	*****	*****	*****	*****	
	-0.5834	-0.9984	-1.4604	-1.3367	-0.7734	*****	*****	*****	*****	

Medium Radius L.E.
 Run No. = 30 , Point No. = 606
 $C_N = 0.243$, $C_m = -0.0297$
 $\alpha = 7.0^\circ$, $M_\infty = 0.601$
 $R_{mac} = 101.3 \times 10^6$



x/c_R	starb'd C_p	port C_p
0.10	-0.2276	*****
0.20	-0.5581	-0.5834
0.30	-0.8224	*****
0.40	-1.0491	-0.9984
0.50	-1.3095	*****
0.60	-1.1151	-1.4604
0.70	-0.5830	*****
0.80	-1.4281	-1.3367
0.90	*****	*****
0.95	-0.8878	-0.7734

Table D3. Continued.

η	$x/c_R = .2$		$x/c_R = .4$		$x/c_R = .6$		$x/c_R = .8$		$x/c_R = .95$	
	$C_{p,u}$	$C_{p,u}$	$C_{p,u}$	$C_{p,u}$	$C_{p,u}$	$C_{p,u}$	$C_{p,u}$	$C_{p,u}$	$C_{p,u}$	$C_{p,u}$
0.050	-0.1479	-0.1029	0.0348	*****	*****	*****	*****	*****	*****	*****
0.100	-0.1499	-0.1062	0.0245	*****	*****	*****	*****	*****	*****	*****
0.150	-0.1567	-0.1100	0.0079	*****	*****	*****	*****	*****	*****	*****
0.200	-0.1609	-0.1091	-0.0057	*****	*****	*****	*****	*****	*****	-0.2846
0.250	*****	-0.1142	-0.0233	-0.1375	-0.1282	*****	*****	*****	*****	-0.2821
0.300	-0.1761	-0.1204	-0.0341	-0.1295	-0.2864	*****	*****	*****	*****	-0.2864
0.350	*****	-0.1267	-0.0497	-0.1258	-0.2856	*****	*****	*****	*****	-0.2856
0.400	-0.2118	-0.1347	-0.0598	-0.1174	-0.2984	*****	*****	*****	*****	-0.2984
0.450	-0.2324	-0.1464	-0.0574	-0.1212	-0.3034	*****	*****	*****	*****	-0.3034
0.500	-0.2538	-0.1564	-0.0901	-0.1239	-0.3130	*****	*****	*****	*****	-0.3130
0.525	*****	-0.1659	-0.0991	-0.1297	-0.3165	*****	*****	*****	*****	-0.3165
0.550	-0.2758	-0.1798	-0.1070	-0.1307	-0.3187	*****	*****	*****	*****	-0.3187
0.575	*****	-0.1898	-0.1057	-0.1361	-0.3244	*****	*****	*****	*****	-0.3244
0.600	-0.3045	-0.2011	-0.1292	-0.1444	-0.3223	*****	*****	*****	*****	-0.3223
0.625	*****	*****	-0.1332	-0.1511	-0.3213	*****	*****	*****	*****	-0.3213
0.650	-0.3345	-0.2221	-0.1465	-0.1603	-0.3228	*****	*****	*****	*****	-0.3228
0.675	*****	-0.2483	-0.1672	-0.1731	-0.3142	*****	*****	*****	*****	-0.3142
0.700	-0.3637	-0.2758	-0.1817	-0.1828	-0.3058	*****	*****	*****	*****	-0.3058
0.725	*****	-0.3053	*****	-0.1946	-0.2945	*****	*****	*****	*****	-0.2945
0.750	-0.3933	-0.3371	*****	-0.2178	-0.2687	*****	*****	*****	*****	-0.2687
0.775	*****	-0.3721	-0.2623	-0.2485	-0.2182	*****	*****	*****	*****	-0.2182
0.800	-0.4166	-0.4127	-0.3040	-0.2756	*****	*****	*****	*****	*****	-0.2756
0.825	*****	-0.4515	-0.3544	-0.2861	-0.1701	*****	*****	*****	*****	-0.1701
0.850	-0.4480	-0.4941	-0.4153	-0.3500	-0.1988	*****	*****	*****	*****	-0.1988
0.875	*****	-0.5403	-0.4858	-0.4116	-0.2870	*****	*****	*****	*****	-0.2870
0.900	-0.4929	-0.5924	-0.5636	-0.5014	-0.4451	*****	*****	*****	*****	-0.4451
0.925	*****	-0.6530	-0.6496	-0.6034	-1.0290	*****	*****	*****	*****	-1.0290
0.950	-0.5686	-0.7257	-0.7571	-0.7243	-0.7988	*****	*****	*****	*****	-0.7988
0.975	*****	-0.8838	-0.9264	-0.9046	-0.7863	*****	*****	*****	*****	-0.7863
1.000	-0.8143	-1.4429	-1.4460	-1.9628	-1.2171	*****	*****	*****	*****	-1.2171
-0.200	$C_{p,l}$	0.1515	0.1435	0.1643	*****	*****	*****	*****	*****	-0.3562
-0.400	0.1431	0.1578	0.1401	0.0011	-0.4131	*****	*****	*****	*****	-0.4131
-0.600	0.1610	0.1559	0.1355	0.0319	-0.4306	*****	*****	*****	*****	-0.4306
-0.700	0.1819	0.1518	0.1416	0.0456	-0.4400	*****	*****	*****	*****	-0.4400
-0.800	0.2101	*****	0.1419	0.0707	-0.4370	*****	*****	*****	*****	-0.4370
-0.850	*****	0.1982	0.1541	0.0813	-0.4651	*****	*****	*****	*****	-0.4651
-0.900	*****	0.2223	0.1780	0.1079	-0.4850	*****	*****	*****	*****	-0.4850
-0.950	0.2283	0.2179	0.2011	0.1519	-0.2143	*****	*****	*****	*****	-0.2143
-0.975	*****	0.1615	0.1595	0.1481	-0.0286	*****	*****	*****	*****	-0.0286
-1.000	-0.8393	-1.3753	-1.9318	-1.8577	-1.0882	*****	*****	*****	*****	-1.0882

Medium Radius L.E.
 Run No. = 30 , Point No. = 607
 $C_N = 0.281$, $C_m = -0.0353$
 $\alpha = 8.1^\circ$, $M_\infty = 0.601$
 $R_{mac} = 101.2 \times 10^6$

Leading Edge Pressures

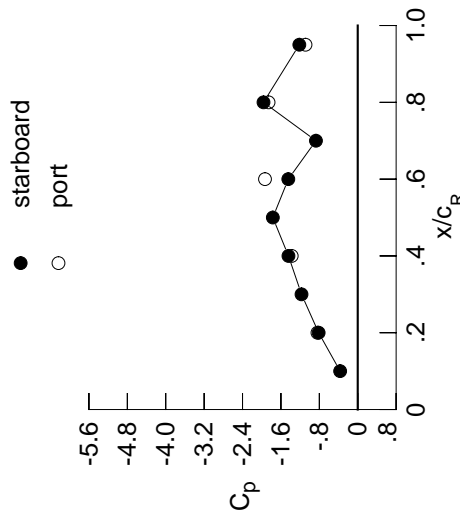

x/c_R	starb'd C_p	port C_p
0.10	-0.3668	*****
0.20	-0.8143	-0.8393
0.30	-1.1709	*****
0.40	-1.4429	-1.3753
0.50	-1.7690	*****
0.60	-1.4460	-1.9318
0.70	-0.8700	*****
0.80	-1.9628	-1.8577
0.90	*****	*****
0.95	-1.2171	-1.0882

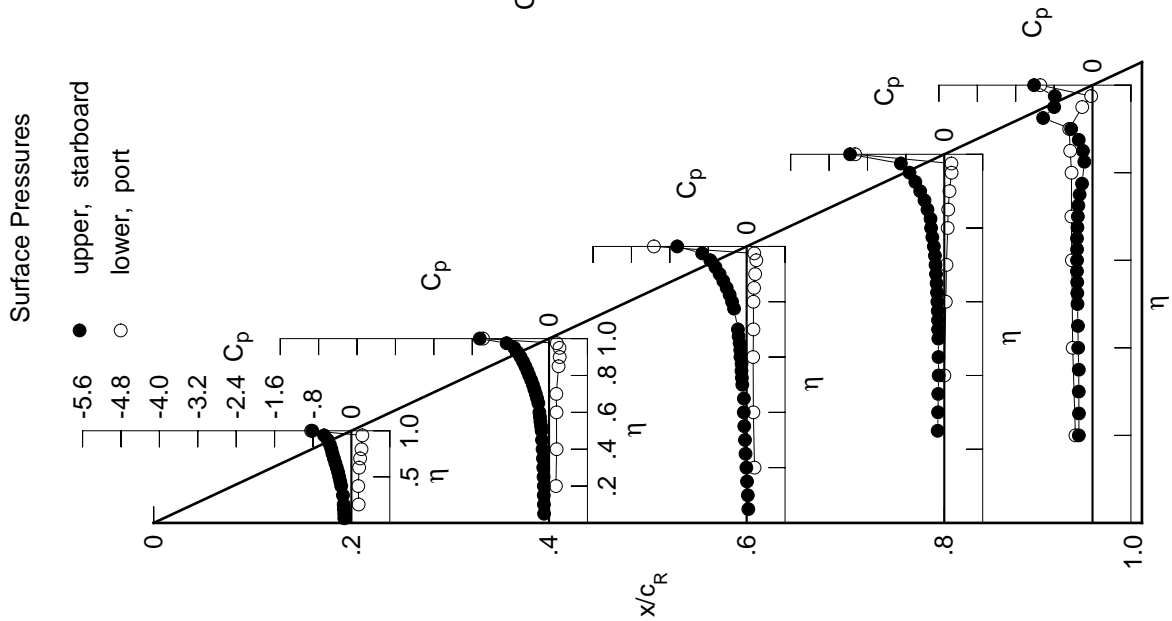

Table D3. Continued.

η	$x/c_R = .2$		$x/c_R = .4$		$x/c_R = .6$		$x/c_R = .8$		$x/c_R = .95$	
	$C_{p,u}$	$C_{p,u}$	$C_{p,u}$	$C_{p,u}$	$C_{p,u}$	$C_{p,u}$	$C_{p,u}$	$C_{p,u}$	$C_{p,u}$	$C_{p,u}$
0.050	-0.1625	-0.1153	0.0236	*****	*****	*****	*****	*****	*****	
0.100	-0.1675	-0.1206	0.0140	*****	*****	*****	*****	*****	*****	
0.150	-0.1746	-0.1244	-0.0043	*****	*****	*****	*****	*****	*****	
0.200	-0.1806	-0.1239	-0.0178	*****	*****	*****	*****	*****	-0.2928	
0.250	*****	-0.1296	-0.0358	-0.1493	-0.2862	*****	*****	*****	*****	
0.300	-0.1954	-0.1374	-0.0474	-0.1418	-0.2862	*****	*****	*****	*****	
0.350	*****	-0.1447	-0.0647	-0.1391	-0.2822	*****	*****	*****	*****	
0.400	-0.2333	-0.1534	-0.0762	-0.1318	-0.2880	*****	*****	*****	*****	
0.450	-0.2561	-0.1668	-0.0746	-0.1362	-0.2880	*****	*****	*****	*****	
0.500	-0.2799	-0.1791	-0.1091	-0.1388	-0.3170	*****	*****	*****	*****	
0.525	*****	-0.1897	-0.1183	-0.1423	-0.3310	*****	*****	*****	*****	
0.550	-0.3044	-0.2039	-0.1268	-0.1395	-0.3425	*****	*****	*****	*****	
0.575	*****	-0.2157	-0.1251	-0.1451	-0.3600	*****	*****	*****	*****	
0.600	-0.3368	-0.2276	-0.1507	-0.1531	-0.3701	*****	*****	*****	*****	
0.625	*****	*****	-0.1542	-0.1562	-0.3763	*****	*****	*****	*****	
0.650	-0.3718	-0.2522	-0.1694	-0.1620	-0.3814	*****	*****	*****	*****	
0.675	*****	-0.2794	-0.1948	-0.1806	-0.3877	*****	*****	*****	*****	
0.700	-0.4061	-0.3094	-0.2206	-0.2298	-0.4277	*****	*****	*****	*****	
0.725	*****	-0.3411	*****	-0.2877	-0.4548	*****	*****	*****	*****	
0.750	-0.4425	-0.3768	*****	-0.3370	-0.4681	*****	*****	*****	*****	
0.775	*****	-0.4164	-0.3330	-0.3775	-0.5290	*****	*****	*****	*****	
0.800	-0.4750	-0.4629	-0.3694	-0.4094	*****	*****	*****	*****	*****	
0.825	*****	-0.5094	-0.4089	-0.4233	-0.5134	*****	*****	*****	*****	
0.850	-0.5173	-0.5591	-0.4661	-0.4271	-0.5025	*****	*****	*****	*****	
0.875	*****	-0.6172	-0.5343	-0.4655	-0.4781	*****	*****	*****	*****	
0.900	-0.5782	-0.6803	-0.6185	-0.5209	-0.4667	*****	*****	*****	*****	
0.925	*****	-0.7595	-0.7215	-0.6303	-0.5996	*****	*****	*****	*****	
0.950	-0.6859	-0.8546	-0.8548	-0.7406	-0.6861	*****	*****	*****	*****	
0.975	*****	-1.0629	-1.0703	-0.9419	-0.8033	*****	*****	*****	*****	
1.000	-1.1081	-1.9328	-1.7336	-2.0436	-1.6163	*****	*****	*****	*****	
-0.200	$C_{p,l}$	0.1641	0.1817	*****	-0.3495	$C_{p,l}$	$C_{p,l}$	$C_{p,l}$	$C_{p,l}$	
-0.400	0.1680	0.1786	0.1579	0.0178	-0.4082	0.1680	0.1786	0.1579	-0.4082	
-0.600	0.1878	0.1779	0.1551	0.0494	-0.3875	0.1878	0.1779	0.1551	-0.3875	
-0.700	0.2083	0.1761	0.1623	0.0654	-0.3790	0.2083	0.1761	0.1623	-0.3790	
-0.800	0.2335	*****	0.1644	0.0924	-0.3805	0.2335	*****	0.1644	-0.3805	
-0.850	*****	0.2212	0.1770	0.1039	-0.4150	*****	0.2212	0.1770	-0.4150	
-0.900	*****	0.2387	0.1978	0.1308	-0.4331	*****	0.2387	0.1978	-0.4331	
-0.950	0.2192	0.2151	0.2040	0.1636	-0.1707	0.2192	0.2151	0.2040	-0.1707	
-0.975	*****	0.1285	0.1337	0.1354	-0.0122	*****	0.1285	0.1337	-0.0122	
-1.000	-1.1315	-1.7902	-1.9871	-2.2237	-1.4830	-1.1315	-1.7902	-1.9871	-2.2237	

Medium Radius L.E.
 Run No. = 30 , Point No. = 608
 $C_N = 0.339$, $C_m = -0.0509$
 $\alpha = 9.1^\circ$, $M_\infty = 0.601$
 $R_{mac} = 101.4 \times 10^6$

Leading Edge Pressures

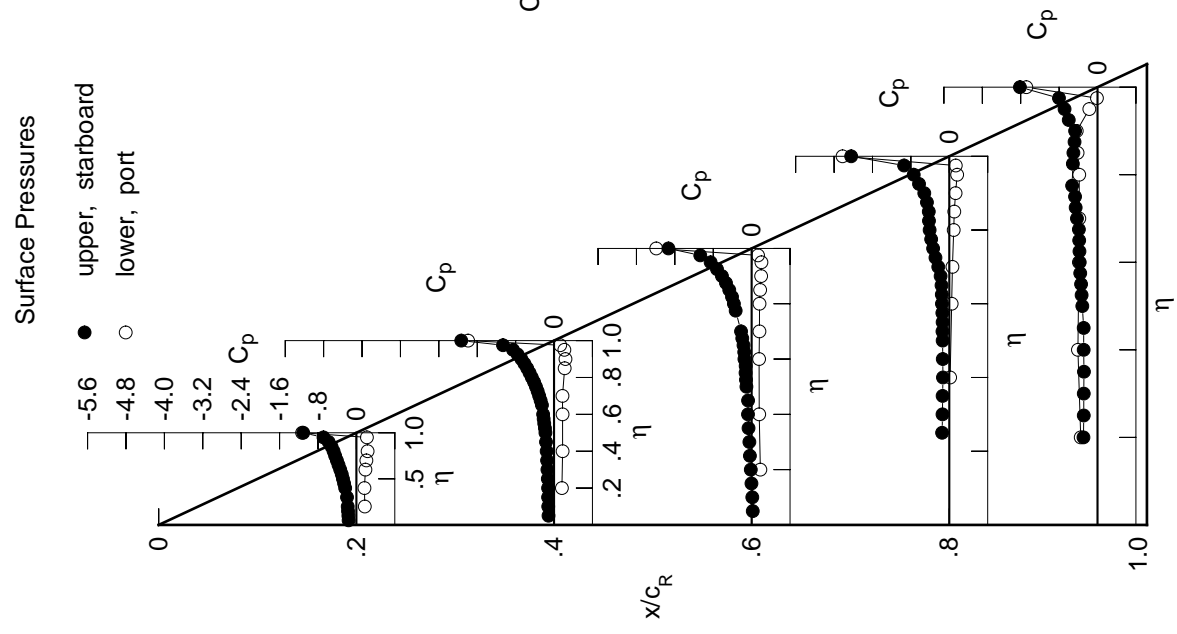
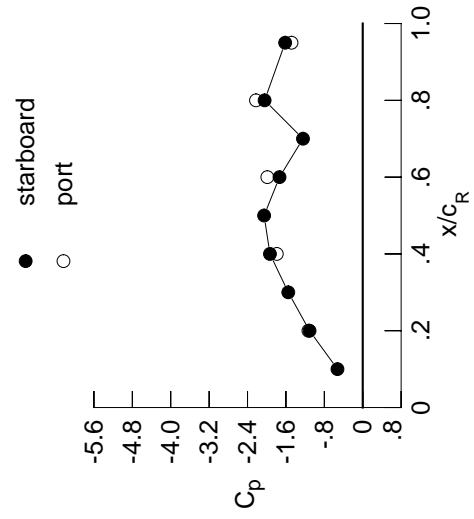

Table D3. Continued.

η	$x/c_R = .2$		$x/c_R = .4$		$x/c_R = .6$		$x/c_R = .8$		$x/c_R = .95$	
	$C_{p,u}$	$C_{p,u}$	$C_{p,u}$	$C_{p,u}$	$C_{p,u}$	$C_{p,u}$	$C_{p,u}$	$C_{p,u}$	$C_{p,u}$	$C_{p,u}$
0.050	-0.1775	-0.1315	0.0077	*****	*****	*****	*****	*****	*****	*****
0.100	-0.1855	-0.1379	-0.0030	*****	*****	*****	*****	*****	*****	*****
0.150	-0.1944	-0.1425	-0.0222	*****	*****	*****	*****	*****	*****	*****
0.200	-0.2020	-0.1433	-0.0364	*****	*****	*****	*****	*****	*****	*****
0.250	*****	-0.1502	-0.0560	-0.1636	-0.1636	-0.1636	-0.1636	-0.1636	-0.1636	-0.1636
0.300	-0.2190	-0.1587	-0.0686	-0.1573	-0.1573	-0.1573	-0.1573	-0.1573	-0.1573	-0.1573
0.350	*****	-0.1670	-0.0874	-0.1525	-0.1525	-0.1525	-0.1525	-0.1525	-0.1525	-0.1525
0.400	-0.2587	-0.1784	-0.0962	-0.1413	-0.1413	-0.1413	-0.1413	-0.1413	-0.1413	-0.1413
0.450	-0.2830	-0.1937	-0.0917	-0.1381	-0.1381	-0.1381	-0.1381	-0.1381	-0.1381	-0.1381
0.500	-0.3092	-0.2052	-0.1259	-0.1353	-0.1353	-0.1353	-0.1353	-0.1353	-0.1353	-0.1353
0.525	*****	-0.2167	-0.1310	-0.1506	-0.1506	-0.1506	-0.1506	-0.1506	-0.1506	-0.1506
0.550	-0.3371	-0.2331	-0.1402	-0.1699	-0.1699	-0.1699	-0.1699	-0.1699	-0.1699	-0.1699
0.575	*****	-0.2476	-0.1433	-0.1982	-0.1982	-0.1982	-0.1982	-0.1982	-0.1982	-0.1982
0.600	-0.3734	-0.2672	-0.1988	-0.2081	-0.2081	-0.2081	-0.2081	-0.2081	-0.2081	-0.2081
0.625	*****	*****	-0.2273	-0.1937	-0.1937	-0.1937	-0.1937	-0.1937	-0.1937	-0.1937
0.650	-0.4133	-0.3097	-0.2698	-0.1794	-0.1794	-0.1794	-0.1794	-0.1794	-0.1794	-0.1794
0.675	*****	-0.3376	-0.3020	-0.1733	-0.1733	-0.1733	-0.1733	-0.1733	-0.1733	-0.1733
0.700	-0.4540	-0.3647	-0.3137	-0.1632	-0.1632	-0.1632	-0.1632	-0.1632	-0.1632	-0.1632
0.725	*****	-0.3951	*****	-0.1476	-0.1476	-0.1476	-0.1476	-0.1476	-0.1476	-0.1476
0.750	-0.4982	-0.4308	*****	-0.1365	-0.1365	-0.1365	-0.1365	-0.1365	-0.1365	-0.1365
0.775	*****	-0.4714	-0.3436	-0.2271	-0.2271	-0.2271	-0.2271	-0.2271	-0.2271	-0.2271
0.800	-0.5410	-0.5199	-0.3674	-0.5413	-0.5413	-0.5413	-0.5413	-0.5413	-0.5413	-0.5413
0.825	*****	-0.5703	-0.4173	-0.8643	-0.8643	-0.8643	-0.8643	-0.8643	-0.8643	-0.8643
0.850	-0.5958	-0.6257	-0.5321	-1.0256	-1.0256	-1.0256	-1.0256	-1.0256	-1.0256	-1.0256
0.875	*****	-0.6936	-0.7552	-1.0330	-1.0330	-1.0330	-1.0330	-1.0330	-1.0330	-1.0330
0.900	-0.6761	-0.7710	-0.9672	-0.9643	-0.9643	-0.9643	-0.9643	-0.9643	-0.9643	-0.9643
0.925	*****	-0.8657	-1.1137	-0.8470	-0.8470	-0.8470	-0.8470	-0.8470	-0.8470	-0.8470
0.950	-0.8213	-0.9813	-1.2187	-0.7437	-0.7437	-0.7437	-0.7437	-0.7437	-0.7437	-0.7437
0.975	*****	-1.2394	-1.2128	-0.6199	-0.6435	-0.6435	-0.6435	-0.6435	-0.6435	-0.6435
1.000	-1.4568	-2.0305	-1.7384	-1.5331	-1.5331	-1.5331	-1.5331	-1.5331	-1.5331	-1.5331
-0.200	$C_{p,l}$	0.1864	0.1991	*****	*****	*****	*****	*****	*****	*****
-0.400	$C_{p,l}$	0.1937	0.2008	0.1769	0.0325	-0.4087	-0.4087	-0.4087	-0.4087	-0.4087
-0.600	$C_{p,l}$	0.2148	0.2018	0.1759	0.0650	-0.4030	-0.4030	-0.4030	-0.4030	-0.4030
-0.700	$C_{p,l}$	0.2346	0.2012	0.1841	0.0822	-0.4047	-0.4047	-0.4047	-0.4047	-0.4047
-0.800	$C_{p,l}$	0.2554	*****	0.1877	0.1104	-0.3825	-0.3825	-0.3825	-0.3825	-0.3825
-0.850	$C_{p,l}$	*****	0.2435	0.2002	0.1237	-0.4059	-0.4059	-0.4059	-0.4059	-0.4059
-0.900	$C_{p,l}$	*****	0.2526	0.2173	0.1506	-0.4172	-0.4172	-0.4172	-0.4172	-0.4172
-0.950	$C_{p,l}$	0.2028	0.2070	0.2078	0.1788	-0.1567	-0.1567	-0.1567	-0.1567	-0.1567
-0.975	$C_{p,l}$	*****	0.0858	0.1157	0.1448	-0.0016	-0.0016	-0.0016	-0.0016	-0.0016
-1.000	$C_{p,l}$	-1.4926	-2.1305	-1.9877	-1.6754	-0.9157	-0.9157	-0.9157	-0.9157	-0.9157

Medium Radius L.E.

Run No. = 30 , Point No. = 609

$C_N = 0.395$, $C_m = -0.0608$

$\alpha = 10.2^\circ$, $M_\infty = 0.600$

$R_{mac} = 101.3 \times 10^6$

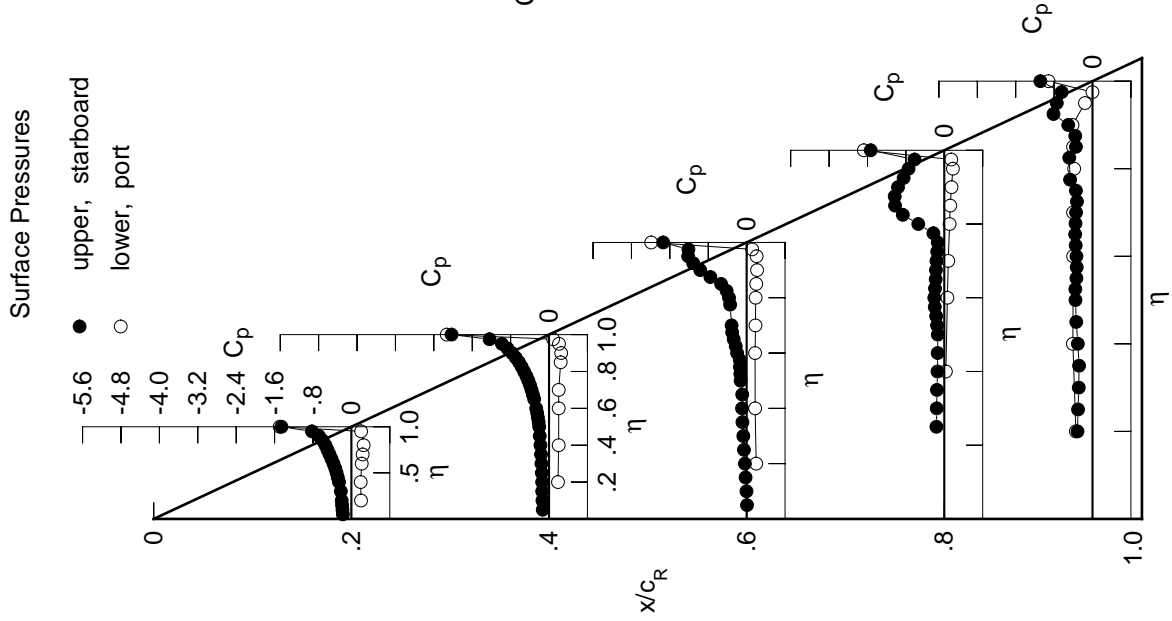

Leading Edge Pressures

● starboard
○ port

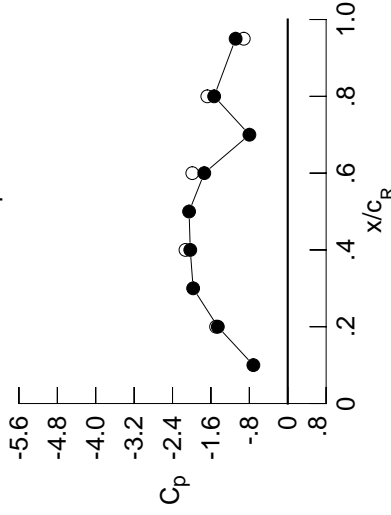

x/c_R	starb'd C_p	port C_p
0.10	-0.7161	*****
0.20	-1.4568	-1.4926
0.30	-1.9703	*****
0.40	-2.0305	-2.1305
0.50	-2.0554	*****
0.60	-1.7384	-1.9877
0.70	-0.7983	*****
0.80	-1.5331	-1.6754
0.90	*****	*****
0.95	-1.0857	-0.9157

Table D3. Continued.

η	$x/c_R = .2$		$x/c_R = .4$		$x/c_R = .6$		$x/c_R = .8$		$x/c_R = .95$	
	$C_{p,u}$	$C_{p,u}$	$C_{p,u}$	$C_{p,u}$	$C_{p,u}$	$C_{p,u}$	$C_{p,u}$	$C_{p,u}$	$C_{p,u}$	$C_{p,u}$
0.050	-0.1937	-0.1586	-0.0134	*****	*****	*****	*****	*****	*****	*****
0.100	-0.2014	-0.1600	-0.0238	*****	*****	*****	*****	*****	*****	*****
0.150	-0.2163	-0.1699	-0.0444	*****	*****	*****	*****	*****	*****	*****
0.200	-0.2240	-0.1699	-0.0597	*****	*****	*****	*****	*****	*****	*****
0.250	*****	-0.1788	-0.0814	-0.1819	-0.1819	-0.3082	*****	*****	*****	*****
0.300	-0.2448	-0.1885	-0.0951	-0.1715	-0.1715	-0.2788	*****	*****	*****	*****
0.350	*****	-0.1999	-0.1069	-0.1619	-0.1619	-0.3001	*****	*****	*****	*****
0.400	-0.2852	-0.2085	-0.1132	-0.1476	-0.1476	-0.3258	*****	*****	*****	*****
0.450	-0.3113	-0.2172	-0.0994	-0.1758	-0.1758	-0.3089	*****	*****	*****	*****
0.500	-0.3399	-0.2347	-0.1702	-0.1817	-0.1817	-0.3100	*****	*****	*****	*****
0.525	*****	-0.2553	-0.2046	-0.1706	-0.1706	-0.3327	*****	*****	*****	*****
0.550	-0.3713	-0.2901	-0.2361	-0.1614	-0.1614	-0.3536	*****	*****	*****	*****
0.575	*****	-0.3222	-0.2341	-0.1584	-0.1584	-0.3767	*****	*****	*****	*****
0.600	-0.4115	-0.3510	-0.2368	-0.1540	-0.1540	-0.3811	*****	*****	*****	*****
0.625	*****	*****	-0.2140	-0.1462	-0.1462	-0.3768	*****	*****	*****	*****
0.650	-0.4570	-0.4090	-0.2101	-0.1381	-0.1381	-0.3636	*****	*****	*****	*****
0.675	*****	-0.4262	-0.2136	-0.1304	-0.1304	-0.3428	*****	*****	*****	*****
0.700	-0.5041	-0.4299	-0.2039	-0.1286	-0.1286	-0.3687	*****	*****	*****	*****
0.725	*****	-0.4457	*****	-0.1768	-0.1768	-0.4823	*****	*****	*****	*****
0.750	-0.5574	-0.4737	*****	-0.3843	-0.3843	-0.6585	*****	*****	*****	*****
0.775	*****	-0.5114	-0.4658	-0.7999	-0.7999	-0.8022	*****	*****	*****	*****
0.800	-0.6104	-0.5540	-0.9118	-1.1203	*****	*****	*****	*****	*****	*****
0.825	*****	-0.5985	-1.2074	-1.3041	-0.6076	*****	*****	*****	*****	*****
0.850	-0.6809	-0.6787	-1.2743	-1.3022	-0.4427	*****	*****	*****	*****	*****
0.875	*****	-0.8201	-1.2296	-1.0300	-0.4416	*****	*****	*****	*****	*****
0.900	-0.7810	-0.9719	-1.1521	-0.7955	-0.4811	*****	*****	*****	*****	*****
0.925	*****	-1.1875	-1.0995	-0.7524	-0.5723	*****	*****	*****	*****	*****
0.950	-0.9660	-1.4799	-1.0759	-0.6601	-0.5580	*****	*****	*****	*****	*****
0.975	*****	-1.6191	-1.0366	-0.5797	-0.4643	*****	*****	*****	*****	*****
1.000	-1.8337	-2.0299	-1.4611	-1.2122	-0.7186	*****	*****	*****	*****	*****
-0.200	$C_{p,l}$	$C_{p,l}$	$C_{p,l}$	$C_{p,l}$	$C_{p,l}$	$C_{p,l}$	$C_{p,l}$	$C_{p,l}$	$C_{p,l}$	$C_{p,l}$
-0.400	0.2277	0.2121	0.2195	*****	*****	-0.3354	*****	*****	*****	*****
-0.600	0.2221	0.2265	0.1984	0.0482	0.0482	-0.4078	*****	*****	*****	*****
-0.700	0.2438	0.2290	0.1985	0.0818	-0.3914	*****	*****	*****	*****	*****
-0.800	0.2621	0.2294	0.2082	0.0988	-0.3806	*****	*****	*****	*****	*****
-0.850	0.2771	*****	0.2127	0.1277	-0.3831	*****	*****	*****	*****	*****
-0.900	*****	0.2678	0.2257	0.1402	-0.4136	*****	*****	*****	*****	*****
-0.950	*****	0.2689	0.2397	0.1656	-0.4209	*****	*****	*****	*****	*****
-0.975	0.1790	0.2035	0.2208	0.1871	-0.1545	*****	*****	*****	*****	*****
-1.000	*****	0.0562	0.1205	0.1484	-0.0023	*****	*****	*****	*****	*****
	-1.9155	-2.1300	-1.9453	-1.1908	-0.6636	*****	*****	*****	*****	*****

Medium Radius L.E.
 Run No. = 30 , Point No. = 610
 $C_N = 0.464$, $C_m = -0.0728$
 $\alpha = 11.3^\circ$, $M_\infty = 0.601$
 $R_{mac} = 101.2 \times 10^6$

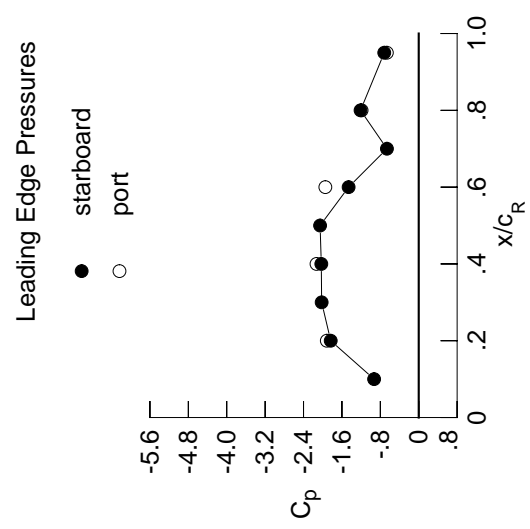

x/c_R	starb'd C_p	port C_p
0.10	-0.9295	*****
0.20	-1.8337	-1.9155
0.30	-2.0226	*****
0.40	-2.0299	-2.1300
0.50	-2.0549	*****
0.60	-1.4611	-1.9453
0.70	-0.6622	*****
0.80	-1.2122	-1.1908
0.90	*****	*****
0.95	-0.7186	-0.6636

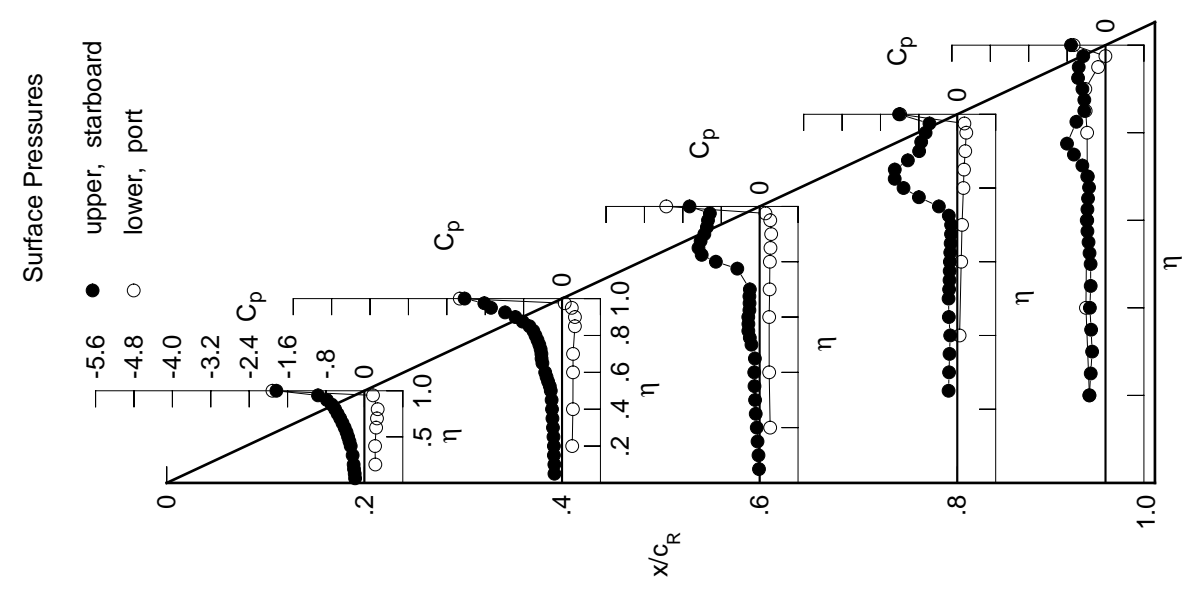

Table D3. Continued.

η	x/c_R .2	x/c_R .4	x/c_R .6	x/c_R .8	x/c_R .95
	$C_{p,u}$	$C_{p,u}$	$C_{p,u}$	$C_{p,u}$	$C_{p,u}$
0.050	-0.2140	-0.1870	-0.0310	*****	*****
0.100	-0.2177	-0.1868	-0.0409	*****	*****
0.150	-0.2379	-0.1957	-0.0611	*****	*****
0.200	-0.2489	-0.1969	-0.0780	*****	-0.3403
0.250	*****	-0.2103	-0.1020	-0.1876	-0.3219
0.300	-0.2755	-0.2241	-0.1045	-0.1730	-0.3242
0.350	*****	-0.2260	-0.1192	-0.1808	-0.3058
0.400	-0.3165	-0.2259	-0.1676	-0.1678	-0.3008
0.450	-0.3432	-0.2535	-0.1521	-0.1588	-0.3407
0.500	-0.3737	-0.3307	-0.1694	-0.1488	-0.3833
0.525	*****	-0.3653	-0.1717	-0.1494	-0.3955
0.550	-0.4078	-0.3697	-0.1759	-0.1396	-0.3978
0.575	*****	-0.3424	-0.1638	-0.1369	-0.4070
0.600	-0.4525	-0.3400	-0.1805	-0.1325	-0.4000
0.625	*****	*****	-0.1648	-0.1298	-0.3999
0.650	-0.5050	-0.3321	-0.1538	-0.1419	-0.4252
0.675	*****	-0.3580	-0.1618	-0.2004	-0.4826
0.700	-0.5598	-0.3841	-0.1986	-0.3461	-0.5961
0.725	*****	-0.4219	*****	-0.6201	-0.7165
0.750	-0.6218	-0.4975	*****	-0.9413	-0.7709
0.775	*****	-0.6386	-1.2732	-1.2193	-0.7430
0.800	-0.6839	-0.8298	-1.4567	-1.2652	*****
0.825	*****	-1.0826	-1.4755	-1.1172	-0.4639
0.850	-0.7673	-1.2839	-1.3732	-0.8125	-0.4316
0.875	*****	-1.3650	-1.2367	-0.7313	-0.4372
0.900	-0.8832	-1.3812	-1.0768	-0.7287	-0.4484
0.925	*****	-1.3905	-0.9964	-0.6821	-0.4786
0.950	-1.1001	-1.4111	-0.9334	-0.6574	-0.4400
0.975	*****	-1.3510	-0.8828	-0.6017	-0.3621
1.000	-2.1076	-2.0281	-1.1960	-1.1903	-0.5666
	$C_{p,l}$	$C_{p,l}$	$C_{p,l}$	$C_{p,l}$	$C_{p,l}$
-0.200	0.2552	0.2355	0.2362	*****	-0.3395
-0.400	0.2509	0.2502	0.2154	0.0582	-0.4173
-0.600	0.2728	0.2531	0.2162	0.0915	-0.4061
-0.700	0.2893	0.2553	0.2267	0.1086	-0.4193
-0.800	0.2980	*****	0.2321	0.1382	-0.4275
-0.850	*****	0.2887	0.2439	0.1522	-0.4482
-0.900	*****	0.2821	0.2543	0.1758	-0.4398
-0.950	0.1553	0.2002	0.2243	0.1891	-0.1580
-0.975	*****	0.0345	0.1136	0.1385	-0.0065
-1.000	-2.1306	-2.1280	-1.5973	-1.1485	-0.5777

Medium Radius L.E.
 Run No. = 30, Point No. = 611
 $C_N = 0.512$, $C_m = -0.0746$
 $\alpha = 12.3^\circ$, $M_\infty = 0.601$
 $R_{mac} = 101.3 \times 10^6$

Leading Edge Pressures

● starboard
 ○ port

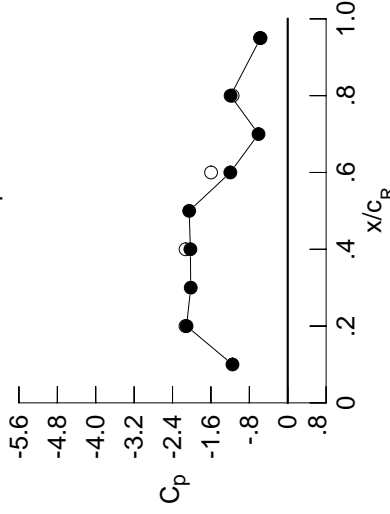

x/c_R	starb'd C_p	port C_p
0.10	-1.1512	*****
0.20	-2.1076	-2.1306
0.30	-2.0208	*****
0.40	-2.0281	-2.1280
0.50	-2.0530	*****
0.60	-1.1960	-1.5973
0.70	-0.6090	*****
0.80	-1.1903	-1.1485
0.90	*****	*****
0.95	-0.5666	-0.5777

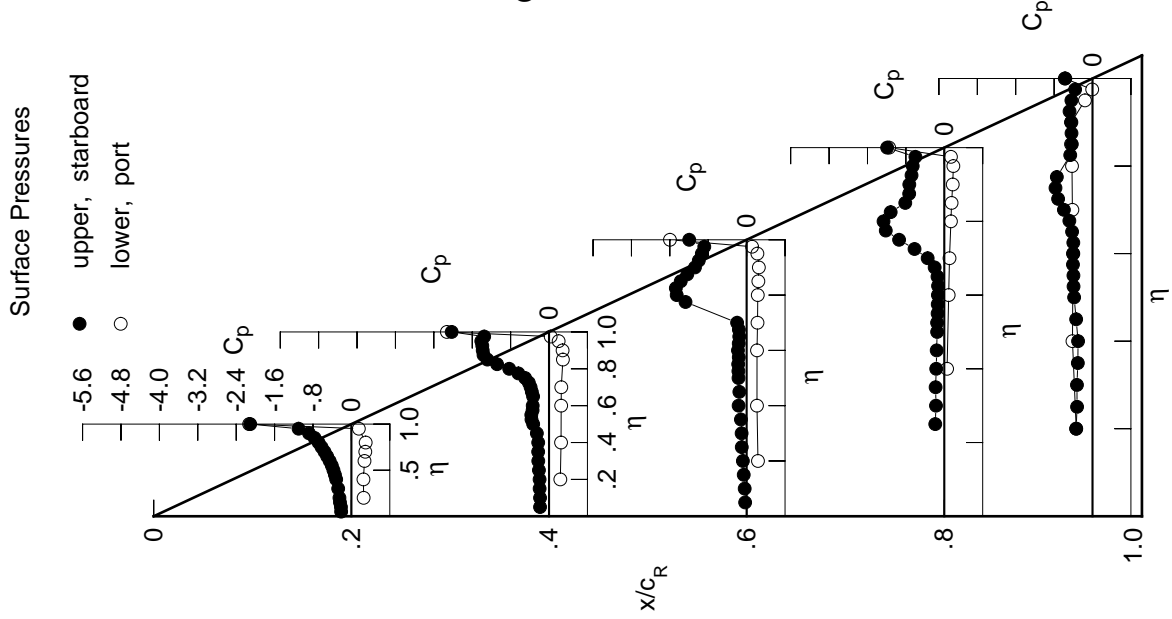
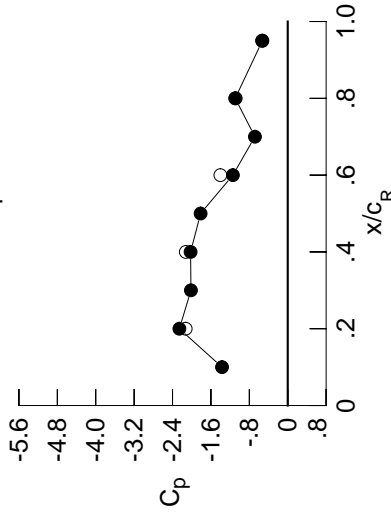

Table D3. Continued.

η	$x/c_R = .2$		$x/c_R = .4$		$x/c_R = .6$		$x/c_R = .8$		$x/c_R = .95$	
	$C_{p,u}$	$C_{p,u}$	$C_{p,u}$	$C_{p,u}$	$C_{p,u}$	$C_{p,u}$	$C_{p,u}$	$C_{p,u}$	$C_{p,u}$	$C_{p,u}$
0.050	-0.2406	-0.2159	-0.0473	*****	*****	*****	*****	*****	*****	*****
0.100	-0.2407	-0.2159	-0.0572	*****	*****	*****	*****	*****	*****	*****
0.150	-0.2613	-0.2219	-0.0750	*****	*****	*****	*****	*****	*****	*****
0.200	-0.2778	-0.2221	-0.0946	*****	*****	*****	*****	*****	*****	*****
0.250	*****	-0.2440	-0.1126	-0.1884	-0.1884	-0.3513	*****	*****	*****	*****
0.300	-0.3123	-0.2440	-0.1235	-0.1851	-0.1851	-0.3511	*****	*****	*****	*****
0.350	*****	-0.2419	-0.1682	-0.1962	-0.1962	-0.3148	*****	*****	*****	*****
0.400	-0.3523	-0.2746	-0.1901	-0.1676	-0.1676	-0.3214	*****	*****	*****	*****
0.450	-0.3796	-0.3348	-0.1617	-0.1575	-0.1575	-0.3661	*****	*****	*****	*****
0.500	-0.4161	-0.3839	-0.1807	-0.1456	-0.1456	-0.4076	*****	*****	*****	*****
0.525	*****	-0.3804	-0.1803	-0.1454	-0.1454	-0.4232	*****	*****	*****	*****
0.550	-0.4589	-0.3726	-0.1826	-0.1380	-0.1380	-0.4276	*****	*****	*****	*****
0.575	*****	-0.3661	-0.1675	-0.1422	-0.1422	-0.4529	*****	*****	*****	*****
0.600	-0.5083	-0.3629	-0.1872	-0.1533	-0.1533	-0.4658	*****	*****	*****	*****
0.625	*****	*****	-0.1766	-0.1854	-0.1854	-0.5049	*****	*****	*****	*****
0.650	-0.5610	-0.3410	-0.1831	-0.2592	-0.2592	-0.5612	*****	*****	*****	*****
0.675	*****	-0.3580	-0.2333	-0.4184	-0.4184	-0.6143	*****	*****	*****	*****
0.700	-0.6161	-0.3558	-0.3564	-0.6593	-0.6593	-0.6699	*****	*****	*****	*****
0.725	*****	-0.3367	*****	-0.9490	-0.7112	*****	*****	*****	*****	*****
0.750	-0.6812	-0.3956	*****	-1.1658	-0.7069	*****	*****	*****	*****	*****
0.775	*****	-0.8297	-1.4843	-1.2351	-0.6716	*****	*****	*****	*****	*****
0.800	-0.7520	-1.3706	-1.6660	-1.0238	*****	*****	*****	*****	*****	*****
0.825	*****	-1.6043	-1.6246	-0.7754	-0.5054	*****	*****	*****	*****	*****
0.850	-0.8408	-1.6189	-1.3416	-0.7135	-0.4696	*****	*****	*****	*****	*****
0.875	*****	-1.5779	-1.1203	-0.7124	-0.4633	*****	*****	*****	*****	*****
0.900	-0.9651	-1.5178	-1.0546	-0.6876	-0.4590	*****	*****	*****	*****	*****
0.925	*****	-1.4498	-0.9992	-0.6413	-0.4545	*****	*****	*****	*****	*****
0.950	-1.5730	-1.4007	-0.9293	-0.6263	-0.3912	*****	*****	*****	*****	*****
0.975	*****	-1.3432	-0.8855	-0.5664	-0.3325	*****	*****	*****	*****	*****
1.000	-2.2576	-2.0238	-1.1427	-1.0942	-0.5282	*****	*****	*****	*****	*****
-0.200	$C_{p,l}$	$C_{p,l}$	$C_{p,l}$	$C_{p,l}$	$C_{p,l}$	$C_{p,l}$	$C_{p,l}$	$C_{p,l}$	$C_{p,l}$	$C_{p,l}$
-0.400	0.2812	0.2573	0.2510	*****	*****	-0.3539	*****	*****	*****	*****
-0.600	0.2789	0.2712	0.2312	0.0685	-0.4213	*****	*****	*****	*****	*****
-0.700	0.3002	0.2755	0.2324	0.1016	-0.4329	*****	*****	*****	*****	*****
-0.800	0.3143	0.2778	0.2430	0.1195	-0.4592	*****	*****	*****	*****	*****
-0.850	0.3166	*****	0.2474	0.1493	-0.4602	*****	*****	*****	*****	*****
-0.900	*****	0.3044	0.2583	0.1631	-0.4703	*****	*****	*****	*****	*****
-0.950	0.1301	0.1929	0.2210	0.1861	-0.4482	*****	*****	*****	*****	*****
-0.975	*****	0.0089	0.0977	0.1296	-0.0094	*****	*****	*****	*****	*****
-1.000	-2.1260	-2.1235	-1.4036	-1.0847	-0.5333	*****	*****	*****	*****	*****

Medium Radius L.E.
 Run No. = 30, Point No. = 612
 $C_N = 0.554$, $C_m = -0.0754$
 $\alpha = 13.4^\circ$, $M_\infty = 0.602$
 $R_{mac} = 101.3 \times 10^6$

Leading Edge Pressures
 ● starboard
 ○ port



x/c_R	starb'd C_p	port C_p
0.10	-1.3690	*****
0.20	-2.2576	-2.1260
0.30	-2.0164	*****
0.40	-2.0238	-2.1235
0.50	-1.8156	*****
0.60	-1.1427	-1.4036
0.70	-0.6834	*****
0.80	-1.0942	-1.0847
0.90	*****	*****
0.95	-0.5282	-0.5333

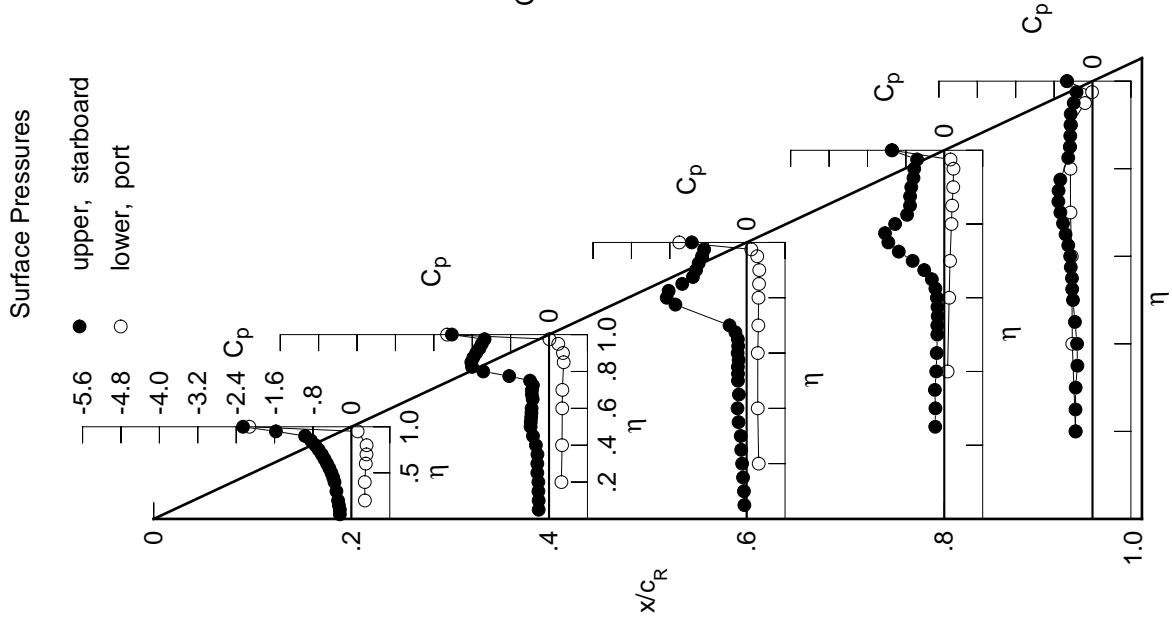
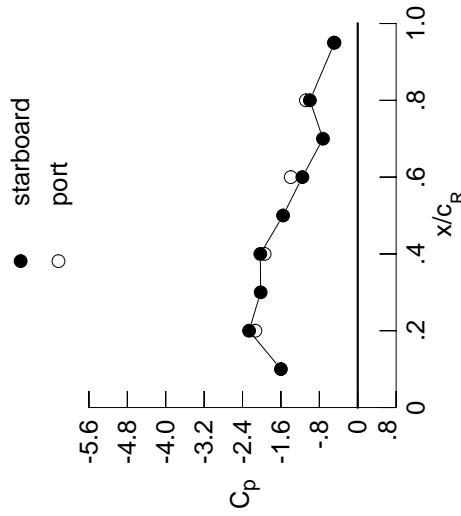

Table D3. Continued.

η	$x/c_R = .2$		$x/c_R = .4$		$x/c_R = .6$		$x/c_R = .8$		$x/c_R = .95$	
	$C_{p,u}$	$C_{p,u}$	$C_{p,u}$	$C_{p,u}$	$C_{p,u}$	$C_{p,u}$	$C_{p,u}$	$C_{p,u}$	$C_{p,u}$	$C_{p,u}$
0.050	-0.2711	-0.2495	-0.0663	*****	*****	*****	*****	*****	*****	*****
0.100	-0.2672	-0.2492	-0.0766	*****	*****	*****	*****	*****	*****	*****
0.150	-0.2862	-0.2537	-0.0955	*****	*****	*****	*****	*****	*****	*****
0.200	-0.3073	-0.2548	-0.1133	*****	*****	*****	*****	*****	*****	*****
0.250	*****	-0.2674	-0.1283	-0.1996	-0.1996	-0.3577	*****	*****	*****	*****
0.300	-0.3539	-0.2636	-0.1492	-0.1946	-0.1946	-0.3577	*****	*****	*****	*****
0.350	*****	-0.2958	-0.1907	-0.1985	-0.1985	-0.3364	*****	*****	*****	*****
0.400	-0.3980	-0.3602	-0.2099	-0.1806	-0.1806	-0.3413	*****	*****	*****	*****
0.450	-0.4415	-0.3676	-0.1931	-0.1728	-0.1728	-0.3613	*****	*****	*****	*****
0.500	-0.4851	-0.3993	-0.2142	-0.1603	-0.1603	-0.3961	*****	*****	*****	*****
0.525	*****	-0.4123	-0.2116	-0.1611	-0.1611	-0.4206	*****	*****	*****	*****
0.550	-0.5192	-0.4206	-0.2115	-0.1629	-0.1629	-0.4291	*****	*****	*****	*****
0.575	*****	-0.4188	-0.1988	-0.1814	-0.1814	-0.4801	*****	*****	*****	*****
0.600	-0.5515	-0.4284	-0.2269	-0.2226	-0.2226	-0.5149	*****	*****	*****	*****
0.625	*****	*****	-0.2303	-0.3042	-0.3042	-0.5798	*****	*****	*****	*****
0.650	-0.5894	-0.4125	-0.2814	-0.4482	-0.4482	-0.6460	*****	*****	*****	*****
0.675	*****	-0.4091	-0.4105	-0.6712	-0.6920	*****	*****	*****	*****	*****
0.700	-0.6449	-0.4049	-0.6279	-0.9308	-0.7352	*****	*****	*****	*****	*****
0.725	*****	-0.4264	*****	-1.1637	-0.7612	*****	*****	*****	*****	*****
0.750	-0.7049	-0.6166	*****	-1.2539	-0.7415	*****	*****	*****	*****	*****
0.775	*****	-1.1160	-1.6672	-1.1736	-0.6860	*****	*****	*****	*****	*****
0.800	-0.7228	-1.5997	-1.7194	-0.8989	*****	*****	*****	*****	*****	*****
0.825	*****	-1.7805	-1.4665	-0.7383	-0.4983	*****	*****	*****	*****	*****
0.850	-0.9534	-1.7654	-1.1255	-0.7173	-0.4556	*****	*****	*****	*****	*****
0.875	*****	-1.7068	-1.0805	-0.7153	-0.4407	*****	*****	*****	*****	*****
0.900	-1.7126	-1.6221	-1.0689	-0.6872	-0.4311	*****	*****	*****	*****	*****
0.925	*****	-1.5276	-1.0111	-0.6416	-0.4288	*****	*****	*****	*****	*****
0.950	-1.8576	-1.4489	-0.9934	-0.6202	-0.3497	*****	*****	*****	*****	*****
0.975	*****	-1.3808	-0.9477	-0.5725	-0.2972	*****	*****	*****	*****	*****
1.000	-2.2641	-2.0296	-1.1534	-0.9964	-0.4840	*****	*****	*****	*****	*****
η	$C_{p,l}$	$C_{p,l}$	$C_{p,l}$	$C_{p,l}$	$C_{p,l}$	$C_{p,l}$	$C_{p,l}$	$C_{p,l}$	$C_{p,l}$	$C_{p,l}$
-0.200	0.3107	0.2816	0.2686	*****	*****	-0.3553	*****	*****	*****	*****
-0.400	0.3086	0.2944	0.2490	0.0817	-0.4222	*****	*****	*****	*****	*****
-0.600	0.3291	0.2987	0.2497	0.1164	-0.4409	*****	*****	*****	*****	*****
-0.700	0.3412	0.3016	0.2600	0.1339	-0.4761	*****	*****	*****	*****	*****
-0.800	0.3374	*****	0.2635	0.1640	-0.4673	*****	*****	*****	*****	*****
-0.850	*****	0.3214	0.2717	0.1777	-0.4680	*****	*****	*****	*****	*****
-0.900	*****	0.2994	0.2708	0.1985	-0.4363	*****	*****	*****	*****	*****
-0.950	0.1138	0.1863	0.2120	0.1931	-0.1409	*****	*****	*****	*****	*****
-0.975	*****	-0.0139	0.0695	0.1158	-0.0006	*****	*****	*****	*****	*****
-1.000	-2.1322	-1.9403	-1.3950	-1.0789	-0.4957	*****	*****	*****	*****	*****

Medium Radius L.E.
 Run No. = 30 , Point No. = 613
 $C_N = 0.613$, $C_m = -0.0828$
 $\alpha = 14.4^\circ$, $M_\infty = 0.601$
 $R_{mac} = 101.2 \times 10^6$

Leading Edge Pressures



x/c_R	starb'd C_p	port C_p
0.10	-1.6005	*****
0.20	-2.2641	-2.1322
0.30	-2.0223	*****
0.40	-2.0296	-1.9403
0.50	-1.5561	*****
0.60	-1.1534	-1.3950
0.70	-0.7246	*****
0.80	-0.9964	-1.0789
0.90	*****	*****
0.95	-0.4840	-0.4957

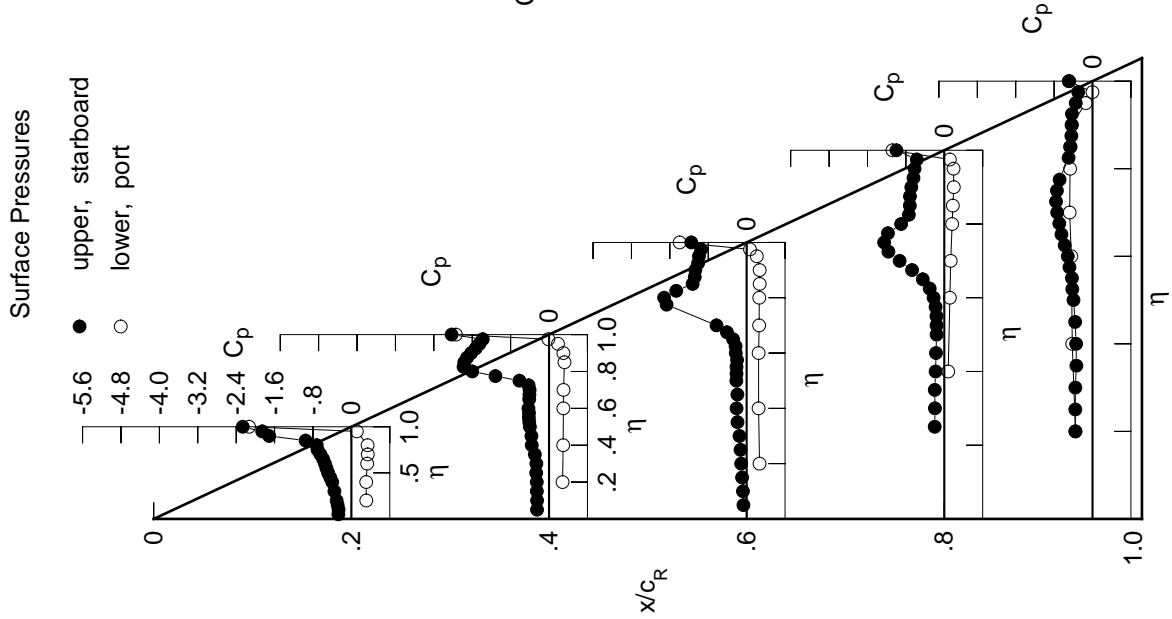
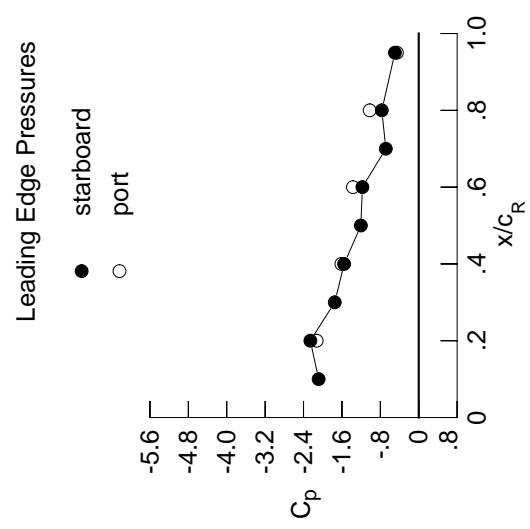

Table D3. Continued.

η	$x/c_R = .2$		$x/c_R = .4$		$x/c_R = .6$		$x/c_R = .8$		$x/c_R = .95$	
	$C_{p,u}$	$C_{p,u}$	$C_{p,u}$	$C_{p,u}$	$C_{p,u}$	$C_{p,u}$	$C_{p,u}$	$C_{p,u}$	$C_{p,u}$	$C_{p,u}$
0.050	-0.3447	-0.3156	-0.0970	*****	*****	*****	*****	*****	*****	*****
0.100	-0.3355	-0.3138	-0.1062	*****	*****	*****	*****	*****	*****	*****
0.150	-0.3498	-0.3207	-0.1234	*****	*****	*****	*****	*****	*****	*****
0.200	-0.3678	-0.3096	-0.1377	*****	*****	*****	*****	*****	*****	*****
0.250	*****	-0.3594	-0.1777	-0.2124	-0.3767	*****	*****	*****	*****	*****
0.300	-0.4349	-0.3554	-0.1718	-0.1955	-0.3629	*****	*****	*****	*****	*****
0.350	*****	-0.3485	-0.1828	-0.1853	-0.3857	*****	*****	*****	*****	*****
0.400	-0.5512	-0.3474	-0.1890	-0.1664	-0.4421	*****	*****	*****	*****	*****
0.450	-0.4967	-0.3482	-0.1700	-0.1714	-0.4904	*****	*****	*****	*****	*****
0.500	-0.4986	-0.3411	-0.2175	-0.2062	-0.5435	*****	*****	*****	*****	*****
0.525	*****	-0.3480	-0.2376	-0.2521	-0.5902	*****	*****	*****	*****	*****
0.550	-0.5216	-0.3632	-0.2775	-0.3257	-0.6147	*****	*****	*****	*****	*****
0.575	*****	-0.3901	-0.3276	-0.4400	-0.6836	*****	*****	*****	*****	*****
0.600	-0.5648	-0.4792	-0.4929	-0.5916	-0.7120	*****	*****	*****	*****	*****
0.625	*****	*****	-0.6474	-0.7728	-0.7435	*****	*****	*****	*****	*****
0.650	-0.5442	-0.9860	-0.9280	-0.9473	-0.7605	*****	*****	*****	*****	*****
0.675	*****	-1.3698	-1.2403	-1.0989	-0.7514	*****	*****	*****	*****	*****
0.700	-0.4738	-1.6824	-1.4910	-1.1668	-0.7544	*****	*****	*****	*****	*****
0.725	*****	-1.8570	*****	-1.1322	-0.7541	*****	*****	*****	*****	*****
0.750	-1.4361	-1.9350	*****	-0.9671	-0.7150	*****	*****	*****	*****	*****
0.775	*****	-1.9168	-1.3024	-0.7713	-0.6487	*****	*****	*****	*****	*****
0.800	-1.9124	-1.8551	-1.0637	-0.6353	*****	*****	*****	*****	*****	*****
0.825	*****	-1.7509	-1.0189	-0.5987	-0.5209	*****	*****	*****	*****	*****
0.850	-1.9130	-1.6146	-1.0138	-0.5946	-0.4696	*****	*****	*****	*****	*****
0.875	*****	-1.4838	-1.0247	-0.5886	-0.4469	*****	*****	*****	*****	*****
0.900	-1.8377	-1.4039	-0.9948	-0.5747	-0.4406	*****	*****	*****	*****	*****
0.925	*****	-1.3285	-1.0087	-0.5476	-0.4625	*****	*****	*****	*****	*****
0.950	-1.7572	-1.2524	-1.0590	-0.5476	-0.3573	*****	*****	*****	*****	*****
0.975	*****	-1.1911	-1.0201	-0.5094	-0.3150	*****	*****	*****	*****	*****
1.000	-2.2579	-1.5543	-1.1735	-0.7688	-0.4960	*****	*****	*****	*****	*****
-0.200	$C_{p,l}$	$C_{p,l}$	$C_{p,l}$	$C_{p,l}$	$C_{p,l}$	$C_{p,l}$	$C_{p,l}$	$C_{p,l}$	$C_{p,l}$	$C_{p,l}$
-0.400	0.3677	0.3280	0.3039	*****	-0.3255	*****	*****	*****	*****	*****
-0.600	0.3651	0.3394	0.2842	0.1088	-0.4219	*****	*****	*****	*****	*****
-0.700	0.3813	0.3430	0.2851	0.1419	-0.4968	*****	*****	*****	*****	*****
-0.800	0.3859	0.3435	0.2946	0.1608	-0.5259	*****	*****	*****	*****	*****
-0.850	0.3666	*****	0.2950	0.1890	-0.4895	*****	*****	*****	*****	*****
-0.900	*****	0.3458	0.2985	0.2023	-0.4724	*****	*****	*****	*****	*****
-0.950	0.0618	0.3058	0.2839	0.2171	-0.4227	*****	*****	*****	*****	*****
-0.975	*****	-0.0798	0.0080	0.0830	0.0018	*****	*****	*****	*****	*****
-1.000	-2.1264	-1.6111	-1.3714	-1.0214	-0.4551	*****	*****	*****	*****	*****

Medium Radius L.E.
 Run No. = 30 , Point No. = 614
 $C_N = 0.719$, $C_m = -0.0904$
 $\alpha = 16.5^\circ$, $M_\infty = 0.602$
 $R_{mac} = 101.4 \times 10^6$



x/c_R	starb'd C_p	port C_p
0.10	-2.0854	*****
0.20	-2.2579	-2.1264
0.30	-1.7496	*****
0.40	-1.5543	-1.6111
0.50	-1.2055	*****
0.60	-1.1735	-1.3714
0.70	-0.6855	*****
0.80	-0.7688	-1.0214
0.90	*****	*****
0.95	-0.4960	-0.4551

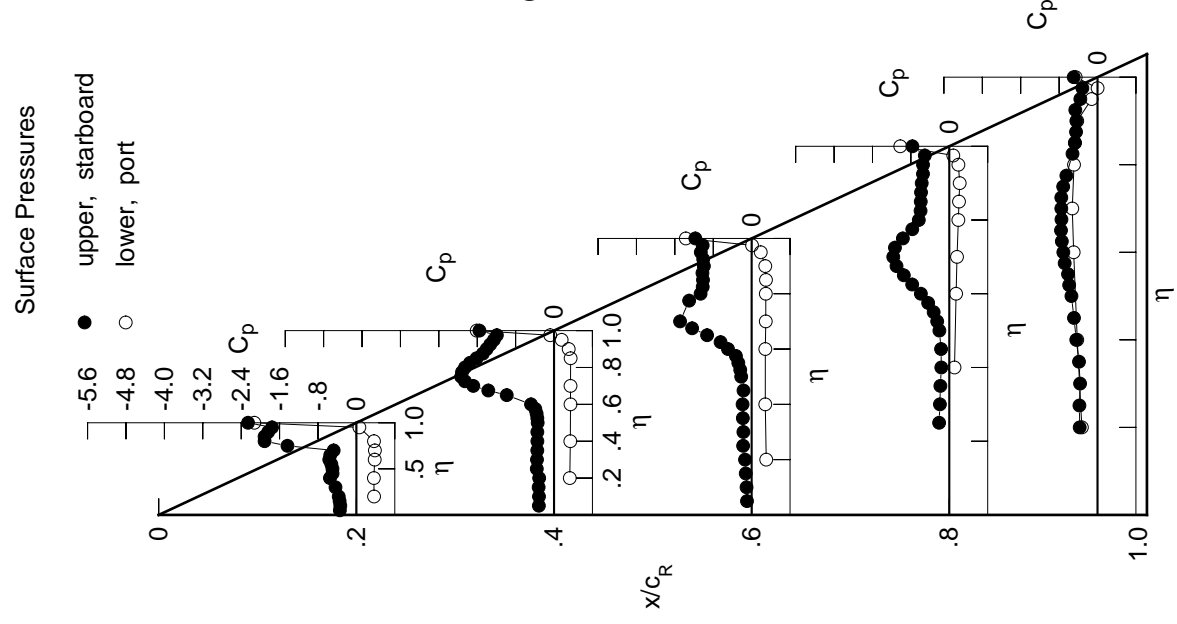
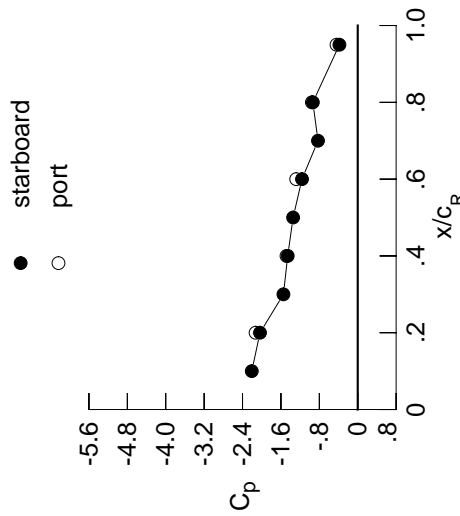

Table D3. Concluded.

η	$x/c_R = .2$		$x/c_R = .4$		$x/c_R = .6$		$x/c_R = .8$		$x/c_R = .95$	
	$C_{p,u}$	$C_{p,l}$	$C_{p,u}$	$C_{p,l}$	$C_{p,u}$	$C_{p,l}$	$C_{p,u}$	$C_{p,l}$	$C_{p,u}$	$C_{p,l}$
0.050	-0.4394	-0.3966	-0.1547	*****	*****	*****	*****	*****	*****	*****
0.100	-0.4291	-0.3955	-0.1653	*****	*****	*****	*****	*****	*****	*****
0.150	-0.4449	-0.3955	-0.1821	*****	*****	*****	*****	*****	*****	*****
0.200	-0.4468	-0.4197	-0.2097	*****	*****	*****	*****	*****	*****	-0.3578
0.250	*****	-0.4238	-0.2355	-0.2560	-0.3668	*****	*****	*****	*****	*****
0.300	-0.4465	-0.4245	-0.2440	-0.2554	-0.3673	*****	*****	*****	*****	*****
0.350	*****	-0.4247	-0.2653	-0.2504	-0.3571	*****	*****	*****	*****	*****
0.400	-0.5240	-0.4281	-0.2922	-0.2535	-0.3876	*****	*****	*****	*****	*****
0.450	-0.5494	-0.4372	-0.3096	-0.2985	-0.4301	*****	*****	*****	*****	*****
0.500	-0.5690	-0.4579	-0.4497	-0.4063	-0.5153	*****	*****	*****	*****	*****
0.525	*****	-0.4993	-0.5480	-0.5060	-0.5935	*****	*****	*****	*****	*****
0.550	-0.5420	-0.5660	-0.6834	-0.6404	-0.6833	*****	*****	*****	*****	*****
0.575	*****	-0.6764	-0.8438	-0.8226	-0.8190	*****	*****	*****	*****	*****
0.600	-0.5065	-0.8652	-1.1127	-1.0333	-0.9470	*****	*****	*****	*****	*****
0.625	*****	*****	-1.3187	-1.2731	-1.0454	*****	*****	*****	*****	*****
0.650	-0.8386	-1.4947	-1.5810	-1.4917	-1.0618	*****	*****	*****	*****	*****
0.675	*****	-1.8888	-1.7802	-1.6376	-0.9619	*****	*****	*****	*****	*****
0.700	-1.9786	-2.0730	-1.7576	-1.5775	-0.7971	*****	*****	*****	*****	*****
0.725	*****	-2.0395	*****	-1.3619	-0.5604	*****	*****	*****	*****	*****
0.750	-2.2012	-1.9605	*****	-1.0592	-0.4158	*****	*****	*****	*****	*****
0.775	*****	-1.9191	-1.1997	-0.8833	-0.4273	*****	*****	*****	*****	*****
0.800	-2.1429	-1.6619	-1.1727	-0.8608	*****	*****	*****	*****	*****	*****
0.825	*****	-1.5829	-1.1723	-0.8326	-0.4232	*****	*****	*****	*****	*****
0.850	-2.0571	-1.5709	-1.1719	-0.8351	-0.3885	*****	*****	*****	*****	*****
0.875	*****	-1.5673	-1.1665	-0.8344	-0.3777	*****	*****	*****	*****	*****
0.900	-1.8296	-1.4824	-1.1258	-0.8044	-0.3750	*****	*****	*****	*****	*****
0.925	*****	-1.3765	-1.1057	-0.7640	-0.3732	*****	*****	*****	*****	*****
0.950	-1.7441	-1.3514	-1.0942	-0.7852	-0.2959	*****	*****	*****	*****	*****
0.975	*****	-1.3226	-1.0736	-0.7479	-0.2573	*****	*****	*****	*****	*****
1.000	-2.0359	-1.4589	-1.1609	-0.9350	-0.3813	*****	*****	*****	*****	*****
-0.200	$C_{p,l}$	$C_{p,l}$	$C_{p,l}$	$C_{p,l}$	$C_{p,l}$	$C_{p,l}$	$C_{p,l}$	$C_{p,l}$	$C_{p,l}$	$C_{p,l}$
-0.400	0.4259	0.3764	0.3436	*****	-0.3388	*****	*****	*****	*****	*****
-0.600	0.4230	0.3862	0.3240	0.1413	-0.4282	*****	*****	*****	*****	*****
-0.700	0.4341	0.3882	0.3242	0.1737	-0.5177	*****	*****	*****	*****	*****
-0.800	0.4312	0.3857	0.3335	0.1919	-0.5386	*****	*****	*****	*****	*****
-0.850	0.3956	*****	0.3284	0.2185	-0.4841	*****	*****	*****	*****	*****
-0.900	*****	0.3662	0.3250	0.2289	-0.4586	*****	*****	*****	*****	*****
-0.950	*****	0.3067	0.2952	0.2365	-0.3970	*****	*****	*****	*****	*****
-0.975	0.0176	0.1200	0.1641	0.1844	-0.1014	*****	*****	*****	*****	*****
-1.000	*****	-0.1584	-0.0561	0.0472	0.0015	*****	*****	*****	*****	*****
	-2.1278	-1.4842	-1.2817	-0.9548	-0.4418	*****	*****	*****	*****	*****

Medium Radius L.E.
 Run No. = 30 , Point No. = 615
 $C_N = 0.863$, $C_m = -0.1115$
 $\alpha = 18.7^\circ$, $M_\infty = 0.601$
 $R_{mac} = 101.3 \times 10^6$

Leading Edge Pressures



x/c_R	starb'd C_p	port C_p
0.10	-2.2070	*****
0.20	-2.0359	-2.1278
0.30	-1.5476	*****
0.40	-1.4589	-1.4842
0.50	-1.3465	*****
0.60	-1.1609	-1.2817
0.70	-0.8276	*****
0.80	-0.9350	-0.9548
0.90	*****	*****
0.95	-0.3813	-0.4418

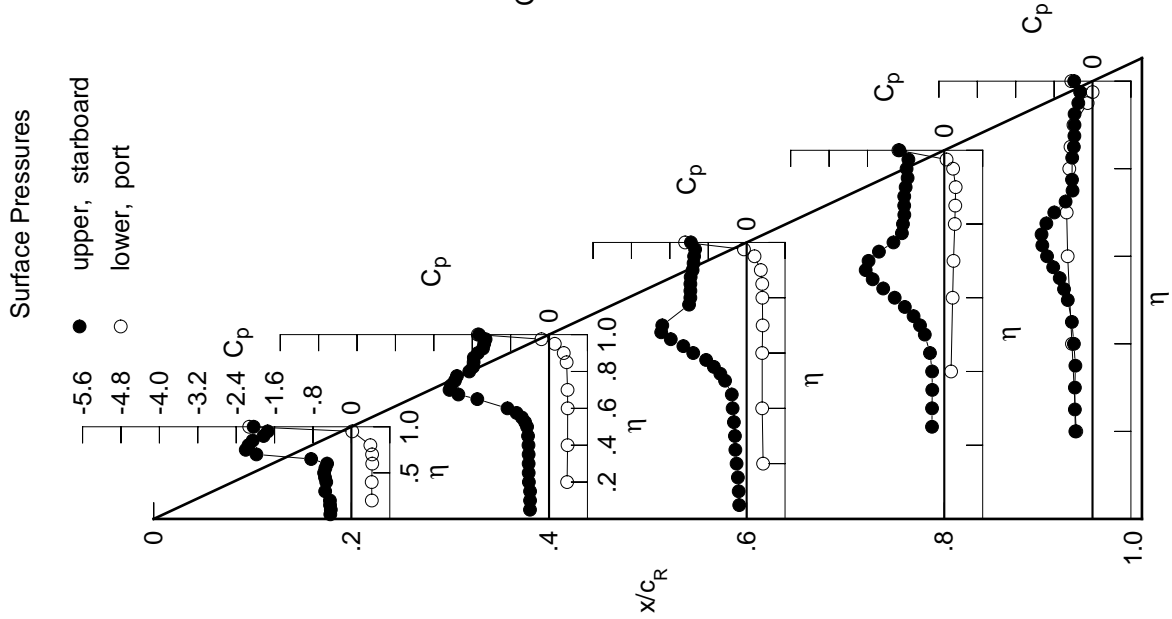

Appendix E

Experimental Surface Pressure Data for 65° Delta Wing, $M_\infty = 0.85$

The experimental surface pressure data for the 65° delta wing at constant $M_\infty = 0.85$ are summarized in tables E1–E11. Because of the extensive data contained in these tables, they have not been included in the printed copy of the paper but are available electronically from the Langley Technical Report Server (LTRS). Open the files with the following Uniform Resource Locator (URL):

Table E1. Tabulations and Plots of Surface Pressure Coefficients.

η	$x/c_R = .2$		$x/c_R = .4$		$x/c_R = .6$		$x/c_R = .8$		$x/c_R = .95$	
	$C_{p,u}$	$C_{p,u}$	$C_{p,u}$	$C_{p,u}$	$C_{p,u}$	$C_{p,u}$	$C_{p,u}$	$C_{p,u}$	$C_{p,u}$	$C_{p,u}$
0.050	-0.0103	0.0056	0.1276	*****	*****	*****	*****	*****	*****	
0.100	-0.0093	0.0049	0.1208	*****	*****	*****	*****	*****	*****	
0.150	-0.0129	0.0062	0.1101	*****	*****	*****	*****	*****	*****	
0.200	-0.0160	0.0086	0.0946	*****	*****	*****	*****	*****	*****	
0.250	*****	0.0060	0.0835	-0.1326	-0.3273	*****	*****	*****	*****	
0.300	-0.0213	0.0028	0.0742	-0.1146	-0.3480	*****	*****	*****	*****	
0.350	*****	0.0036	0.0624	-0.1054	-0.3969	*****	*****	*****	*****	
0.400	-0.0343	0.0016	0.0529	-0.0933	-0.4627	*****	*****	*****	*****	
0.450	-0.0392	0.0004	0.0509	-0.0889	-0.4928	*****	*****	*****	*****	
0.500	-0.0486	-0.0005	0.0408	-0.0829	-0.5099	*****	*****	*****	*****	
0.525	*****	-0.0019	0.0378	-0.0785	-0.5376	*****	*****	*****	*****	
0.550	-0.0527	-0.0058	0.0333	-0.0804	-0.5490	*****	*****	*****	*****	
0.575	*****	-0.0058	0.0333	-0.0763	-0.5727	*****	*****	*****	*****	
0.600	-0.0565	-0.0105	0.0244	-0.0728	-0.5967	*****	*****	*****	*****	
0.625	*****	*****	0.0235	-0.0723	-0.6222	*****	*****	*****	*****	
0.650	-0.0559	-0.0285	0.0216	-0.0713	-0.6612	*****	*****	*****	*****	
0.675	*****	-0.0362	0.0157	-0.0697	-0.6945	*****	*****	*****	*****	
0.700	-0.0522	-0.0403	0.0139	-0.0704	-0.7300	*****	*****	*****	*****	
0.725	*****	-0.0443	*****	-0.0706	-0.7417	*****	*****	*****	*****	
0.750	-0.0426	-0.0515	*****	-0.0703	-0.7304	*****	*****	*****	*****	
0.775	*****	-0.0577	-0.0214	-0.0701	-0.6786	*****	*****	*****	*****	
0.800	-0.0269	-0.0610	-0.0287	-0.0771	*****	*****	*****	*****	*****	
0.825	*****	-0.0630	-0.0379	-0.0891	-0.5676	*****	*****	*****	*****	
0.850	-0.0033	-0.0570	-0.0521	-0.1025	-0.5785	*****	*****	*****	*****	
0.875	*****	-0.0488	-0.0543	-0.1096	-0.5752	*****	*****	*****	*****	
0.900	0.0297	-0.0326	-0.0510	-0.1202	-0.6172	*****	*****	*****	*****	
0.925	*****	-0.0113	-0.0366	-0.1114	-0.5645	*****	*****	*****	*****	
0.950	0.0781	0.0230	-0.0052	-0.0855	-0.3864	*****	*****	*****	*****	
0.975	*****	0.0762	0.0500	-0.0221	-0.2147	*****	*****	*****	*****	
1.000	0.1943	0.1878	0.1444	0.1327	0.0562	*****	*****	*****	*****	
η	$C_{p,i}$	$C_{p,i}$	$C_{p,i}$	$C_{p,i}$	$C_{p,i}$	$C_{p,i}$	$C_{p,i}$	$C_{p,i}$	$C_{p,i}$	
-0.200	-0.0361	-0.0075	0.0795	*****	-0.2808	*****	*****	*****	*****	
-0.400	-0.0633	-0.0099	0.0348	-0.1049	-0.4130	*****	*****	*****	*****	
-0.600	-0.0881	-0.0216	0.0060	-0.0897	-0.5276	*****	*****	*****	*****	
-0.700	-0.0902	-0.0738	-0.0098	-0.0894	-0.6978	*****	*****	*****	*****	
-0.800	-0.0747	-0.1022	-0.0723	-0.1006	-0.6633	*****	*****	*****	*****	
-0.850	-0.0558	-0.1055	-0.0962	-0.1400	-0.5800	*****	*****	*****	*****	
-0.900	*****	-0.0933	-0.1107	-0.1740	-0.5132	*****	*****	*****	*****	
-0.950	0.0254	-0.0445	-0.0813	-0.1601	-0.3945	*****	*****	*****	*****	
-0.975	*****	0.0080	-0.0301	-0.1078	-0.2654	*****	*****	*****	*****	
-1.000	0.1906	0.1760	0.1531	0.1253	0.0574	*****	*****	*****	*****	

Medium Radius L.E.
 Run No. = 7, Point No. = 127
 $C_N = -0.016$, $C_m = -0.0042$
 $\alpha = -0.4^\circ$, $M_\infty = 0.849$
 $R_{mac} = 6.0 \times 10^6$

Surface Pressures

● upper, starboard
 ○ lower, port

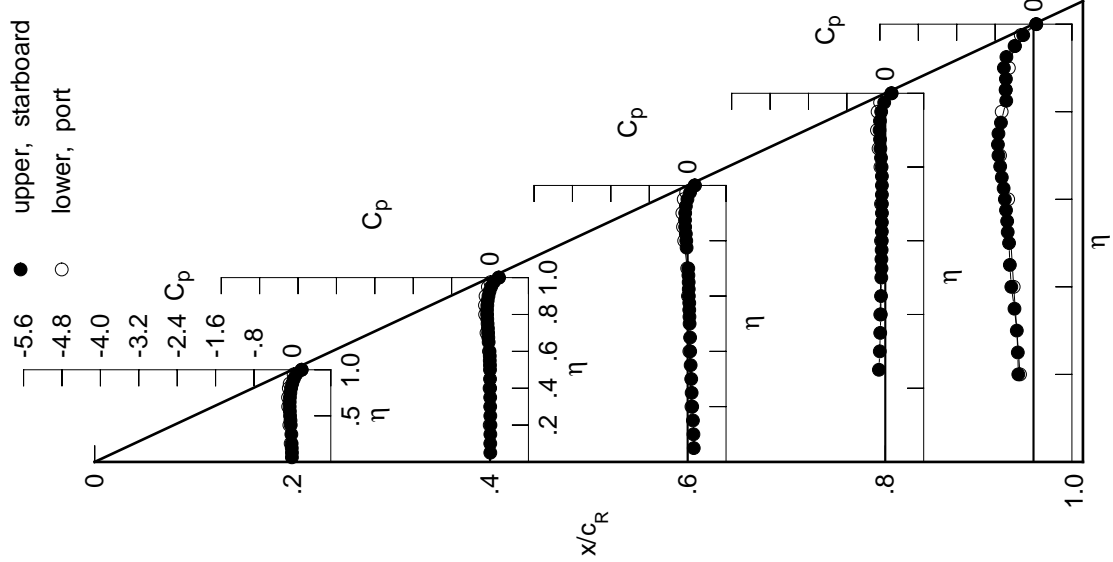

Leading Edge Pressures

● starboard
 ○ port

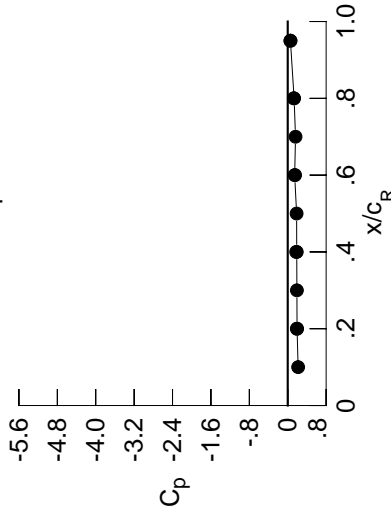

x/c_R	starb'd C_p	port C_p
0.10	0.2165	*****
0.20	0.1943	0.1906
0.30	0.1910	*****
0.40	0.1878	0.1760
0.50	0.1850	*****
0.60	0.1444	0.1531
0.70	0.1623	*****
0.80	0.1327	0.1253
0.90	*****	*****
0.95	0.0562	0.0574

Table E1. Continued.

η	$x/c_R = .2$		$x/c_R = .4$		$x/c_R = .6$		$x/c_R = .8$		$x/c_R = .95$	
	$C_{p,u}$	$C_{p,u}$	$C_{p,u}$	$C_{p,u}$	$C_{p,u}$	$C_{p,u}$	$C_{p,u}$	$C_{p,u}$	$C_{p,u}$	$C_{p,u}$
0.050	-0.0187	-0.0015	0.1227	*****	*****	*****	*****	*****	*****	
0.100	-0.0197	-0.0002	0.1155	*****	*****	*****	*****	*****	*****	
0.150	-0.0223	-0.0016	0.1032	*****	*****	*****	*****	*****	*****	
0.200	-0.0241	-0.0001	0.0889	*****	*****	*****	*****	*****	-0.3018	
0.250	*****	-0.0007	0.0757	-0.1370	-0.3159	*****	*****	*****	*****	
0.300	-0.0313	-0.0035	0.0689	-0.1191	-0.3433	*****	*****	*****	*****	
0.350	*****	-0.0033	0.0548	-0.1101	-0.3883	*****	*****	*****	*****	
0.400	-0.0419	-0.0057	0.0483	-0.0983	-0.4414	*****	*****	*****	*****	
0.450	-0.0512	-0.0088	0.0430	-0.0931	-0.4719	*****	*****	*****	*****	
0.500	-0.0623	-0.0080	0.0332	-0.0876	-0.4931	*****	*****	*****	*****	
0.525	*****	-0.0095	0.0296	-0.0870	-0.5200	*****	*****	*****	*****	
0.550	-0.0653	-0.0146	0.0252	-0.0844	-0.5305	*****	*****	*****	*****	
0.575	*****	-0.0138	0.0275	-0.0826	-0.5513	*****	*****	*****	*****	
0.600	-0.0686	-0.0189	0.0166	-0.0798	-0.5761	*****	*****	*****	*****	
0.625	*****	*****	0.0171	-0.0762	-0.6038	*****	*****	*****	*****	
0.650	-0.0705	-0.0464	0.0112	-0.0765	-0.6459	*****	*****	*****	*****	
0.675	*****	-0.0520	0.0094	-0.0797	-0.6846	*****	*****	*****	*****	
0.700	-0.0674	-0.0538	0.0041	-0.0778	-0.7256	*****	*****	*****	*****	
0.725	*****	-0.0588	*****	-0.0784	-0.7455	*****	*****	*****	*****	
0.750	-0.0590	-0.0651	*****	-0.0761	-0.7378	*****	*****	*****	*****	
0.775	*****	-0.0731	-0.0378	-0.0749	-0.7108	*****	*****	*****	*****	
0.800	-0.0437	-0.0781	-0.0441	-0.0859	*****	*****	*****	*****	*****	
0.825	*****	-0.0796	-0.0550	-0.1051	-0.6403	*****	*****	*****	*****	
0.850	-0.0221	-0.0788	-0.0685	-0.1162	-0.5589	*****	*****	*****	*****	
0.875	*****	-0.0688	-0.0730	-0.1280	-0.5620	*****	*****	*****	*****	
0.900	0.0093	-0.0576	-0.0719	-0.1394	-0.5674	*****	*****	*****	*****	
0.925	*****	-0.0369	-0.0606	-0.1375	-0.5383	*****	*****	*****	*****	
0.950	0.0570	-0.0011	-0.0331	-0.1117	-0.3991	*****	*****	*****	*****	
0.975	*****	0.0514	0.0210	-0.0519	-0.2365	*****	*****	*****	*****	
1.000	0.1979	0.1929	0.1561	0.1444	0.0652	*****	*****	*****	*****	
-0.200	$C_{p,l}$	$C_{p,l}$	$C_{p,l}$	$C_{p,l}$	$C_{p,l}$	$C_{p,l}$	$C_{p,l}$	$C_{p,l}$	$C_{p,l}$	
-0.400	-0.0252	-0.0008	0.0840	*****	*****	-0.2875	*****	*****	*****	
-0.600	-0.0507	-0.0017	0.0422	-0.0973	-0.4291	*****	*****	*****	*****	
-0.700	-0.0734	-0.0565	-0.0001	-0.0791	-0.6771	*****	*****	*****	*****	
-0.800	-0.0546	-0.0823	-0.0527	-0.0838	-0.6660	*****	*****	*****	*****	
-0.850	-0.0353	-0.0834	-0.0774	-0.1222	-0.5949	*****	*****	*****	*****	
-0.900	*****	-0.0679	-0.0850	-0.1519	-0.5328	*****	*****	*****	*****	
-0.950	0.0481	-0.0139	-0.0488	-0.1295	-0.3795	*****	*****	*****	*****	
-0.975	*****	0.0401	0.0049	-0.0719	-0.2388	*****	*****	*****	*****	
-1.000	0.1975	0.1876	0.1687	0.1440	0.0719	*****	*****	*****	*****	

Medium Radius L.E.
 Run No. = 7, Point No. = 128
 $C_N = 0.001$, $C_m = -0.0056$
 $\alpha = 0.0^\circ$, $M_\infty = 0.850$
 $R_{mac} = 6.0 \times 10^6$

Leading Edge Pressures

● starboard
 ○ port

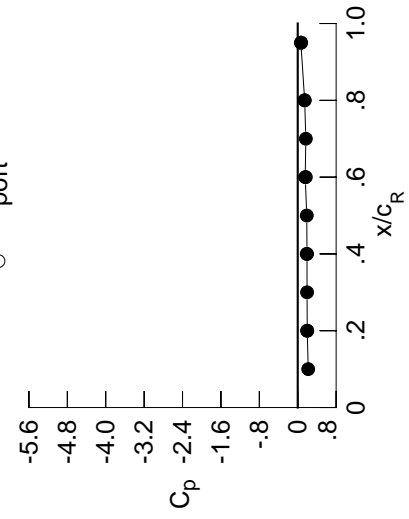

x/c_R	starb'd C_p	port C_p
0.10	0.2188	*****
0.20	0.1979	0.1975
0.30	0.1942	*****
0.40	0.1929	0.1876
0.50	0.1884	*****
0.60	0.1561	0.1687
0.70	0.1685	*****
0.80	0.1444	0.1440
0.90	*****	*****
0.95	0.0652	0.0719

Surface Pressures

● upper, starboard
 ○ lower, port

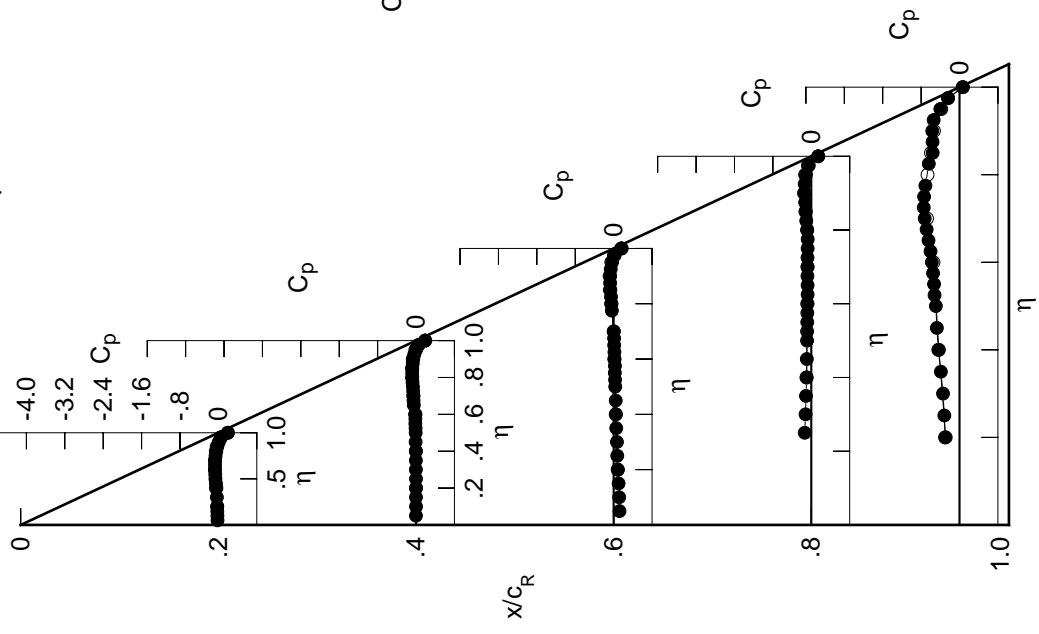

Table E1. Continued.

η	x/c_R .2	x/c_R .4	x/c_R .6	x/c_R .8	x/c_R .95
	$C_{p,u}$	$C_{p,u}$	$C_{p,u}$	$C_{p,u}$	$C_{p,u}$
0.050	-0.0383	-0.0187	0.1120	*****	*****
0.100	-0.0375	-0.0192	0.1013	*****	*****
0.150	-0.0409	-0.0203	0.0926	*****	*****
0.200	-0.0415	-0.0158	0.0757	*****	-0.2923
0.250	*****	-0.0170	0.0644	-0.1495	-0.2965
0.300	-0.0515	-0.0196	0.0539	-0.1330	-0.3174
0.350	*****	-0.0207	0.0431	-0.1217	-0.3534
0.400	-0.0681	-0.0224	0.0322	-0.1116	-0.3968
0.450	-0.0796	-0.0275	0.0290	-0.1062	-0.4306
0.500	-0.0882	-0.0277	0.0158	-0.1013	-0.4466
0.525	*****	-0.0281	0.0155	-0.0998	-0.4658
0.550	-0.0913	-0.0342	0.0087	-0.0966	-0.4779
0.575	*****	-0.0308	0.0104	-0.0968	-0.4875
0.600	-0.0981	-0.0310	-0.0007	-0.0951	-0.4937
0.625	*****	*****	-0.0033	-0.0959	-0.5004
0.650	-0.1003	-0.0813	-0.0055	-0.0948	-0.5569
0.675	*****	-0.0857	-0.0091	-0.0944	-0.6397
0.700	-0.1024	-0.0890	-0.0126	-0.0953	-0.7123
0.725	*****	-0.0911	*****	-0.0963	-0.7475
0.750	-0.0951	-0.0982	*****	-0.0976	-0.7485
0.775	*****	-0.1103	-0.0758	-0.0979	-0.7323
0.800	-0.0832	-0.1162	-0.0924	-0.0985	*****
0.825	*****	-0.1228	-0.0957	-0.1469	-0.6504
0.850	-0.0639	-0.1244	-0.1071	-0.1542	-0.5447
0.875	*****	-0.1205	-0.1219	-0.1678	-0.5485
0.900	-0.0349	-0.1101	-0.1254	-0.1874	-0.5333
0.925	*****	-0.0932	-0.1170	-0.1919	-0.5231
0.950	0.0088	-0.0629	-0.0978	-0.1747	-0.4299
0.975	*****	-0.0156	-0.0537	-0.1293	-0.2918
1.000	0.1839	0.1716	0.1352	0.1158	0.0448
	$C_{p,l}$	$C_{p,l}$	$C_{p,l}$	$C_{p,l}$	$C_{p,l}$
-0.200	-0.0043	0.0175	0.0995	*****	-0.3108
-0.400	-0.0254	0.0148	0.0590	-0.0839	-0.4625
-0.600	-0.0454	0.0047	0.0314	-0.0648	-0.6045
-0.700	-0.0403	-0.0265	0.0204	-0.0610	-0.6846
-0.800	-0.0172	-0.0463	-0.0209	-0.0638	-0.7105
-0.850	0.0059	-0.0401	-0.0393	-0.0898	-0.6656
-0.900	*****	-0.0180	-0.0364	-0.1069	-0.5899
-0.950	0.0928	0.0399	0.0109	-0.0690	-0.3526
-0.975	*****	0.0960	0.0686	-0.0058	-0.1928
-1.000	0.1907	0.1758	0.1525	0.1316	0.0622

Medium Radius L.E.

Run No. = 7, Point No. = 129

$C_N = 0.039$, $C_m = -0.0101$

$\alpha = 1.1^\circ$, $M_\infty = 0.849$

$R_{mac} = 6.0 \times 10^6$

Leading Edge Pressures

- starboard
- port

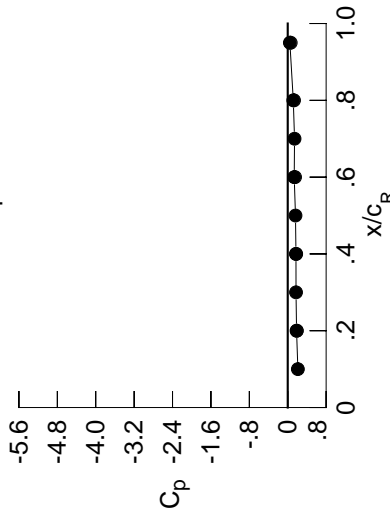

x/c_R	starb'd C_p	port C_p
0.10	0.2114	*****
0.20	0.1839	0.1907
0.30	0.1726	*****
0.40	0.1716	0.1758
0.50	0.1616	*****
0.60	0.1352	0.1525
0.70	0.1418	*****
0.80	0.1158	0.1316
0.90	*****	*****
0.95	0.0448	0.0622

Surface Pressures

- upper, starboard
- lower, port

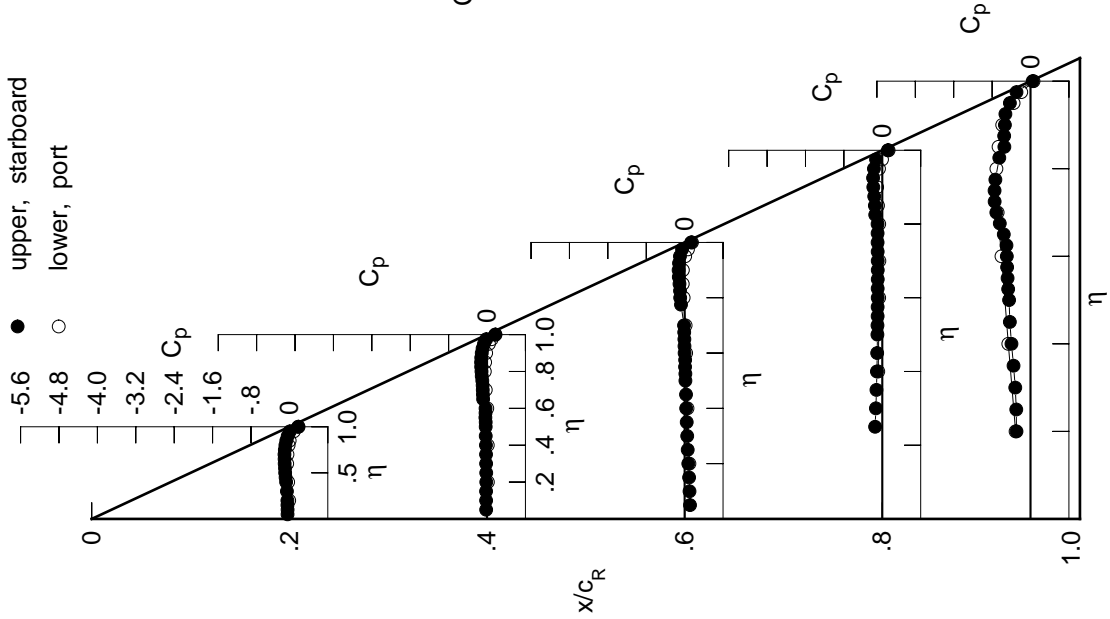

Table E1. Continued.

η	$x/c_R = .2$		$x/c_R = .4$		$x/c_R = .6$		$x/c_R = .8$		$x/c_R = .95$	
	$C_{p,u}$	$C_{p,l}$	$C_{p,u}$	$C_{p,l}$	$C_{p,u}$	$C_{p,l}$	$C_{p,u}$	$C_{p,l}$	$C_{p,u}$	$C_{p,l}$
0.050	-0.0573	-0.0377	0.0979	0.0979	0.0979	0.0979	0.0979	0.0979	0.0979	0.0979
0.100	-0.0540	-0.0349	0.0901	0.0901	0.0901	0.0901	0.0901	0.0901	0.0901	0.0901
0.150	-0.0614	-0.0372	0.0773	0.0773	0.0773	0.0773	0.0773	0.0773	0.0773	0.0773
0.200	-0.0617	-0.0346	0.0653	0.0653	0.0653	0.0653	0.0653	0.0653	0.0653	0.0653
0.250	0.0000	-0.0351	0.0490	0.0490	0.0490	0.0490	0.0490	0.0490	0.0490	0.0490
0.300	-0.0711	-0.0391	0.0420	0.0420	0.0420	0.0420	0.0420	0.0420	0.0420	0.0420
0.350	0.0000	-0.0392	0.0263	0.0263	0.0263	0.0263	0.0263	0.0263	0.0263	0.0263
0.400	-0.0945	-0.0437	0.0197	0.0197	0.0197	0.0197	0.0197	0.0197	0.0197	0.0197
0.450	-0.1071	-0.0466	0.0140	0.0140	0.0140	0.0140	0.0140	0.0140	0.0140	0.0140
0.500	-0.1135	-0.0510	0.0004	0.0004	0.0004	0.0004	0.0004	0.0004	0.0004	0.0004
0.525	0.0000	-0.0505	-0.0038	-0.0038	-0.0038	-0.0038	-0.0038	-0.0038	-0.0038	-0.0038
0.550	-0.1195	-0.0568	-0.0088	-0.0088	-0.0088	-0.0088	-0.0088	-0.0088	-0.0088	-0.0088
0.575	0.0000	-0.0579	-0.0094	-0.0094	-0.0094	-0.0094	-0.0094	-0.0094	-0.0094	-0.0094
0.600	-0.1278	-0.0573	-0.0192	-0.0192	-0.0192	-0.0192	-0.0192	-0.0192	-0.0192	-0.0192
0.625	0.0000	0.0000	-0.0198	-0.0198	-0.0198	-0.0198	-0.0198	-0.0198	-0.0198	-0.0198
0.650	-0.1342	-0.0834	-0.0271	-0.0271	-0.0271	-0.0271	-0.0271	-0.0271	-0.0271	-0.0271
0.675	0.0000	-0.1235	-0.0333	-0.0333	-0.0333	-0.0333	-0.0333	-0.0333	-0.0333	-0.0333
0.700	-0.1381	-0.1295	-0.0387	-0.0387	-0.0387	-0.0387	-0.0387	-0.0387	-0.0387	-0.0387
0.725	0.0000	-0.1308	0.0000	0.0000	0.0000	0.0000	0.0000	0.0000	0.0000	0.0000
0.750	-0.1346	-0.1375	0.0000	0.0000	0.0000	0.0000	0.0000	0.0000	0.0000	0.0000
0.775	0.0000	-0.1485	-0.0660	-0.0660	-0.0660	-0.0660	-0.0660	-0.0660	-0.0660	-0.0660
0.800	-0.1264	-0.1586	-0.1301	-0.1329	-0.1329	-0.1329	-0.1329	-0.1329	-0.1329	-0.1329
0.825	0.0000	-0.1685	-0.1414	-0.1360	-0.1360	-0.1360	-0.1360	-0.1360	-0.1360	-0.1360
0.850	-0.1119	-0.1710	-0.1529	-0.2042	-0.2042	-0.2042	-0.2042	-0.2042	-0.2042	-0.2042
0.875	0.0000	-0.1739	-0.1699	-0.2138	-0.2138	-0.2138	-0.2138	-0.2138	-0.2138	-0.2138
0.900	-0.0864	-0.1718	-0.1836	-0.2374	-0.2374	-0.2374	-0.2374	-0.2374	-0.2374	-0.2374
0.925	0.0000	-0.1603	-0.1864	-0.2538	-0.2538	-0.2538	-0.2538	-0.2538	-0.2538	-0.2538
0.950	-0.0490	-0.1352	-0.1784	-0.2483	-0.2483	-0.2483	-0.2483	-0.2483	-0.2483	-0.2483
0.975	0.0000	-0.1012	-0.1424	-0.2214	-0.2214	-0.2214	-0.2214	-0.2214	-0.2214	-0.2214
1.000	0.1442	0.1001	0.0591	0.0148	0.0148	0.0148	0.0148	0.0148	0.0148	0.0148
	$C_{p,l}$	$C_{p,l}$	$C_{p,l}$	$C_{p,l}$	$C_{p,l}$	$C_{p,l}$	$C_{p,l}$	$C_{p,l}$	$C_{p,l}$	$C_{p,l}$
-0.200	0.0155	0.0343	0.1106	0.0000	0.0000	0.0000	0.0000	0.0000	0.0000	0.0000
-0.400	-0.0043	0.0342	0.0725	-0.0712	-0.0712	-0.0712	-0.0712	-0.0712	-0.0712	-0.0712
-0.600	-0.0164	0.0267	0.0494	-0.0506	-0.0506	-0.0506	-0.0506	-0.0506	-0.0506	-0.0506
-0.700	-0.0074	0.0057	0.0373	-0.0453	-0.0453	-0.0453	-0.0453	-0.0453	-0.0453	-0.0453
-0.800	0.0209	-0.0088	0.0162	-0.0427	-0.0427	-0.0427	-0.0427	-0.0427	-0.0427	-0.0427
-0.850	0.0452	0.0013	-0.0011	-0.0523	-0.0523	-0.0523	-0.0523	-0.0523	-0.0523	-0.0523
-0.900	0.0000	0.0288	0.0102	-0.0656	-0.0656	-0.0656	-0.0656	-0.0656	-0.0656	-0.0656
-0.950	0.1322	0.0893	0.0643	-0.0150	-0.0150	-0.0150	-0.0150	-0.0150	-0.0150	-0.0150
-0.975	0.0000	0.1426	0.1202	0.0504	0.0504	0.0504	0.0504	0.0504	0.0504	0.0504
-1.000	0.1558	0.1154	0.0662	0.0451	0.0451	0.0451	0.0451	0.0451	0.0451	0.0451

Medium Radius L.E.

Run No. = 7, Point No. = 130

$C_N = 0.082$, $C_m = -0.0185$

$\alpha = 2.1^\circ$, $M_\infty = 0.849$

$R_{mac} = 6.0 \times 10^6$

Leading Edge Pressures

- starboard
- port

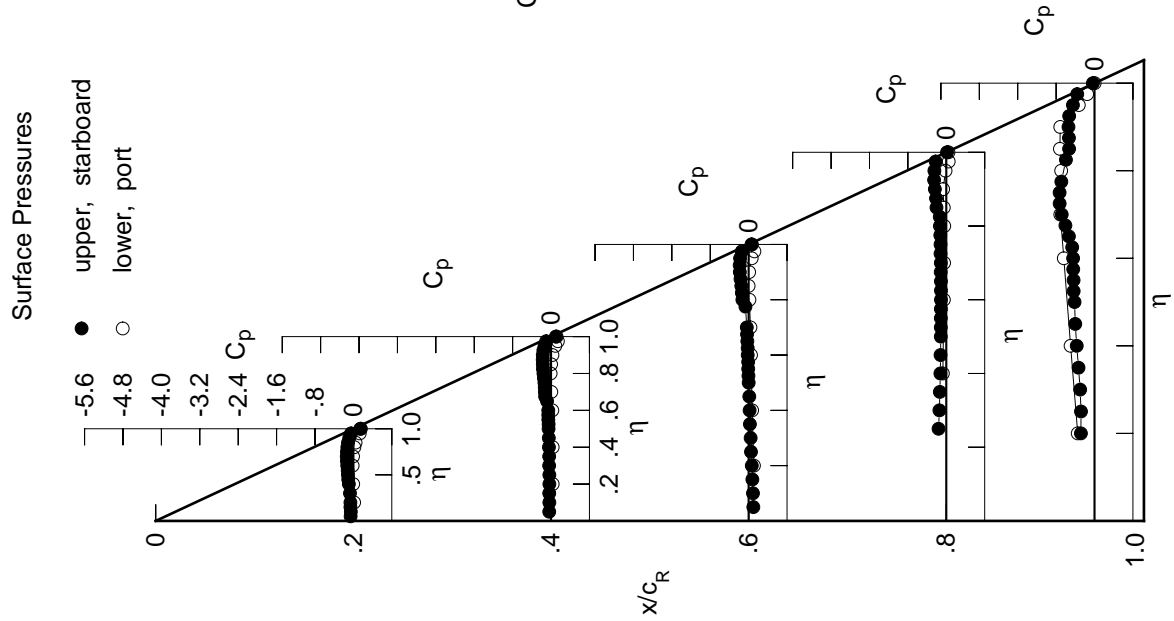
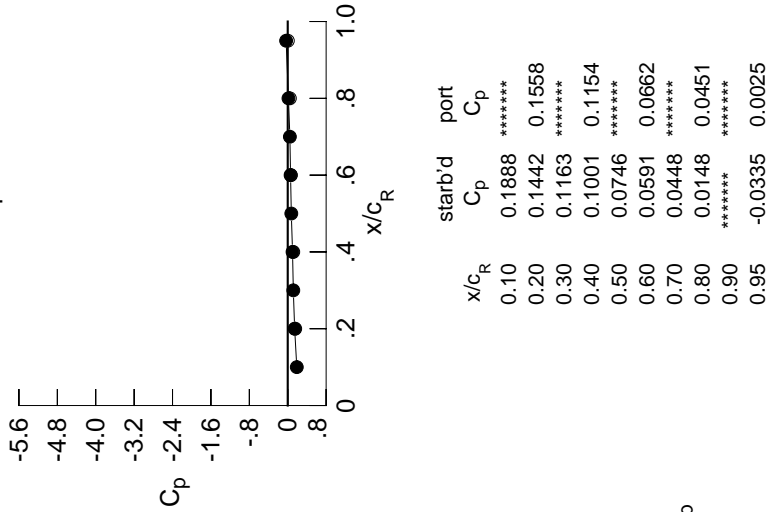

Table E1. Continued.

η	x/c_R .2	x/c_R .4	x/c_R .6	x/c_R .8	x/c_R .95
	$C_{p,u}$	$C_{p,u}$	$C_{p,u}$	$C_{p,u}$	$C_{p,u}$
0.050	-0.0761	-0.0564	0.0855	*****	*****
0.100	-0.0753	-0.0527	0.0771	*****	*****
0.150	-0.0788	-0.0562	0.0644	*****	*****
0.200	-0.0821	-0.0521	0.0493	*****	-0.2970
0.250	*****	-0.0555	0.0360	-0.1759	-0.2880
0.300	-0.0928	-0.0574	0.0263	-0.1565	-0.2863
0.350	*****	-0.0624	0.0130	-0.1485	-0.2999
0.400	-0.1126	-0.0641	0.0027	-0.1395	-0.3306
0.450	-0.1230	-0.0702	-0.0043	-0.1338	-0.3505
0.500	-0.1344	-0.0740	-0.0181	-0.1307	-0.3587
0.525	*****	-0.0791	-0.0210	-0.1295	-0.3710
0.550	-0.1415	-0.0861	-0.0292	-0.1319	-0.3730
0.575	*****	-0.0909	-0.0313	-0.1296	-0.3842
0.600	-0.1543	-0.0937	-0.0409	-0.1283	-0.3925
0.625	*****	*****	-0.0452	-0.1299	-0.3998
0.650	-0.1613	-0.1105	-0.0530	-0.1329	-0.4007
0.675	*****	-0.1221	-0.0599	-0.1374	-0.3848
0.700	-0.1697	-0.1389	-0.0695	-0.1387	-0.3659
0.725	*****	-0.1498	*****	-0.1438	-0.3320
0.750	-0.1683	-0.1664	*****	-0.1490	-0.2679
0.775	*****	-0.1815	-0.1124	-0.1585	-0.1996
0.800	-0.1637	-0.1990	-0.1357	-0.1723	*****
0.825	*****	-0.2110	-0.1614	-0.1848	-0.2183
0.850	-0.1522	-0.2200	-0.1939	-0.2170	-0.2468
0.875	*****	-0.2267	-0.2200	-0.2503	-0.3831
0.900	-0.1342	-0.2282	-0.2422	-0.2892	-0.7904
0.925	*****	-0.2265	-0.2520	-0.3159	-1.1091
0.950	-0.1097	-0.2092	-0.2580	-0.3282	-0.5385
0.975	*****	-0.1952	-0.2443	-0.3220	-0.4481
1.000	0.0803	-0.0122	-0.0403	-0.1480	-0.1638
	$C_{p,l}$	$C_{p,l}$	$C_{p,l}$	$C_{p,l}$	$C_{p,l}$
-0.200	0.0351	0.0496	0.1231	*****	-0.3693
-0.400	0.0215	0.0519	0.0867	-0.0592	-0.5319
-0.600	0.0113	0.0448	0.0665	-0.0368	-0.6688
-0.700	0.0242	0.0304	0.0566	-0.0287	-0.7082
-0.800	0.0545	0.0248	0.0420	-0.0241	-0.6801
-0.850	0.0786	0.0394	0.0344	-0.0278	-0.6991
-0.900	*****	0.0698	0.0494	-0.0243	-0.7174
-0.950	0.1629	0.1291	0.1055	0.0285	-0.3008
-0.975	*****	0.1742	0.1563	0.0902	-0.1204
-1.000	0.0929	0.0081	-0.0837	-0.1068	-0.1001

Medium Radius L.E.
 Run No. = 7, Point No. = 131
 $C_N = 0.122$, $C_m = -0.0242$
 $\alpha = 3.1^\circ$, $M_\infty = 0.850$
 $R_{mac} = 6.0 \times 10^6$

Leading Edge Pressures

● starboard
 ○ port

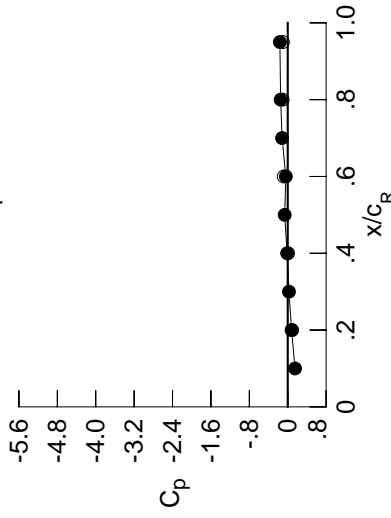

x/c_R	starb'd C_p	port C_p
0.10	0.1521	*****
0.20	0.0803	0.0929
0.30	0.0254	*****
0.40	-0.0122	0.0081
0.50	-0.0637	*****
0.60	-0.0403	-0.0837
0.70	-0.1173	*****
0.80	-0.1480	-0.1068
0.90	*****	*****
0.95	-0.1638	-0.1001

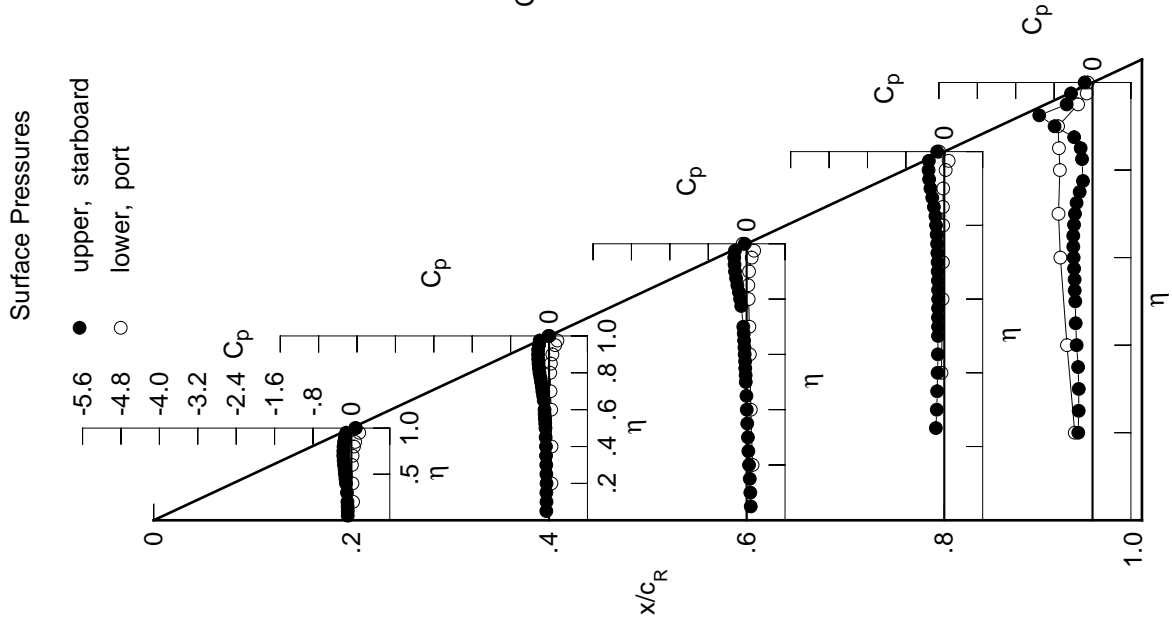
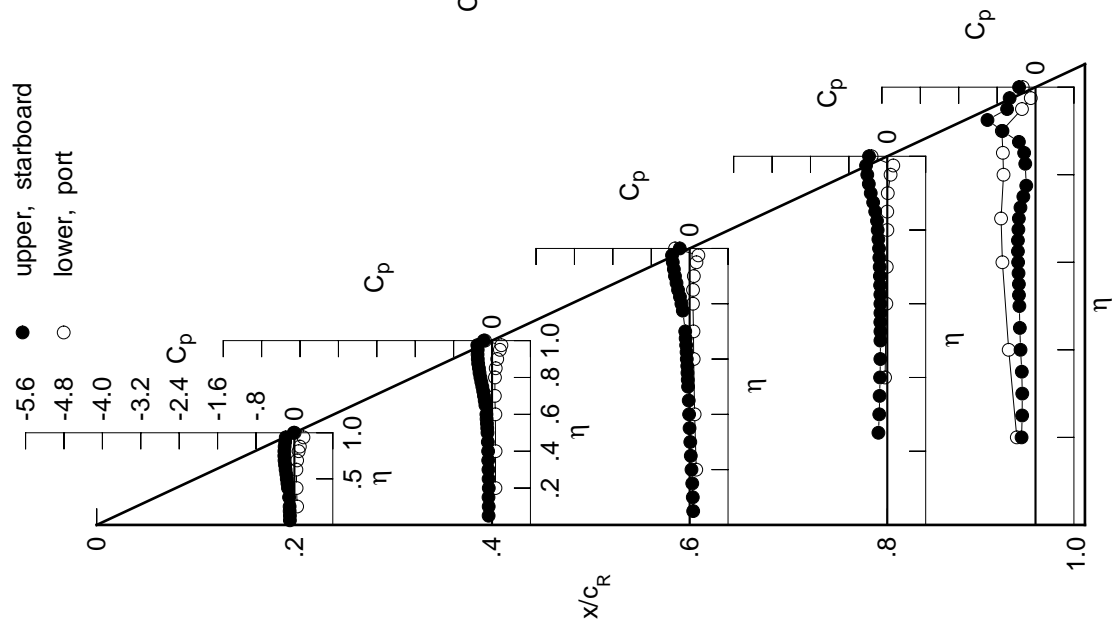

Table E1. Continued.

η	$x/c_R = 0.2$		$x/c_R = 0.4$		$x/c_R = 0.6$		$x/c_R = 0.8$		$x/c_R = 0.95$	
	$C_{p,u}$	$C_{p,u}$	$C_{p,u}$	$C_{p,u}$	$C_{p,u}$	$C_{p,u}$	$C_{p,u}$	$C_{p,u}$	$C_{p,u}$	$C_{p,u}$
0.050	-0.0934	-0.0712	0.0735	0.0735	0.0735	0.0735	0.0735	0.0735	0.0735	0.0735
0.100	-0.0933	-0.0692	0.0656	0.0656	0.0656	0.0656	0.0656	0.0656	0.0656	0.0656
0.150	-0.0987	-0.0733	0.0547	0.0547	0.0547	0.0547	0.0547	0.0547	0.0547	0.0547
0.200	-0.0991	-0.0683	0.0383	0.0383	0.0383	0.0383	0.0383	0.0383	0.0383	0.0383
0.250	0.0000	-0.0721	0.0244	0.0244	0.1845	0.1845	0.2781	0.2781	0.2781	0.2781
0.300	-0.1110	-0.0754	0.0136	0.0136	0.1670	0.1670	0.2764	0.2764	0.2764	0.2764
0.350	0.0000	-0.0800	-0.0015	-0.1600	-0.2854	-0.2854	-0.3120	-0.3120	-0.3120	-0.3120
0.400	-0.1335	-0.0817	-0.0116	-0.1502	-0.3120	-0.3120	-0.3266	-0.3266	-0.3266	-0.3266
0.450	-0.1454	-0.0879	-0.0195	-0.1446	-0.3266	-0.3266	-0.3361	-0.3361	-0.3361	-0.3361
0.500	-0.1584	-0.0955	-0.0330	-0.1434	-0.3361	-0.3361	-0.3446	-0.3446	-0.3446	-0.3446
0.525	0.0000	-0.1000	-0.0389	-0.1435	-0.3446	-0.3446	-0.3462	-0.3462	-0.3462	-0.3462
0.550	-0.1687	-0.1065	-0.0457	-0.1455	-0.3462	-0.3462	-0.3533	-0.3533	-0.3533	-0.3533
0.575	0.0000	-0.1138	-0.0492	-0.1431	-0.3533	-0.3533	-0.3622	-0.3622	-0.3622	-0.3622
0.600	-0.1830	-0.1178	-0.0592	-0.1444	-0.3622	-0.3622	-0.3661	-0.3661	-0.3661	-0.3661
0.625	0.0000	0.0000	-0.0643	-0.1452	-0.3661	-0.3661	-0.3661	-0.3661	-0.3661	-0.3661
0.650	-0.1948	-0.1380	-0.0730	-0.1494	-0.3661	-0.3661	-0.3661	-0.3661	-0.3661	-0.3661
0.675	0.0000	-0.1524	-0.0835	-0.1542	-0.3666	-0.3666	-0.3666	-0.3666	-0.3666	-0.3666
0.700	-0.2057	-0.1677	-0.0918	-0.1580	-0.3470	-0.3470	-0.3470	-0.3470	-0.3470	-0.3470
0.725	0.0000	-0.1843	0.0000	-0.1655	-0.3140	-0.3140	-0.3140	-0.3140	-0.3140	-0.3140
0.750	-0.2093	-0.2026	0.0000	-0.1721	-0.2535	-0.2535	-0.2535	-0.2535	-0.2535	-0.2535
0.775	0.0000	-0.2232	-0.1426	-0.1857	-0.1932	-0.1932	-0.1932	-0.1932	-0.1932	-0.1932
0.800	-0.2087	-0.2423	-0.1717	-0.2001	0.0000	0.0000	0.0000	0.0000	0.0000	0.0000
0.825	0.0000	-0.2609	-0.2017	-0.2145	-0.2137	-0.2137	-0.2137	-0.2137	-0.2137	-0.2137
0.850	-0.2032	-0.2729	-0.2415	-0.2522	-0.2370	-0.2370	-0.2370	-0.2370	-0.2370	-0.2370
0.875	0.0000	-0.2886	-0.2734	-0.2941	-0.3466	-0.3466	-0.3466	-0.3466	-0.3466	-0.3466
0.900	-0.1923	-0.2969	-0.3058	-0.3449	-0.6880	-0.6880	-0.6880	-0.6880	-0.6880	-0.6880
0.925	0.0000	-0.3019	-0.3292	-0.3850	-1.0012	-1.0012	-1.0012	-1.0012	-1.0012	-1.0012
0.950	-0.1799	-0.2984	-0.3512	-0.4170	-0.5922	-0.5922	-0.5922	-0.5922	-0.5922	-0.5922
0.975	0.0000	-0.3071	-0.3669	-0.4424	-0.5391	-0.5391	-0.5391	-0.5391	-0.5391	-0.5391
1.000	-0.0138	-0.1724	-0.2053	-0.3812	-0.3427	-0.3427	-0.3427	-0.3427	-0.3427	-0.3427

Surface Pressures



Medium Radius L.E.
 Run No. = 7, Point No. = 132
 $C_N = 0.163$, $C_m = -0.0311$
 $\alpha = 4.2^\circ$, $M_\infty = 0.849$
 $R_{mac} = 6.0 \times 10^6$

Leading Edge Pressures

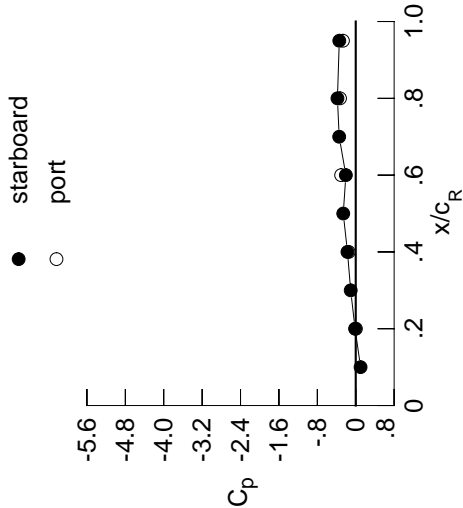

x/c_R	starb'd C_p	port C_p
0.10	0.1010	0.0040
0.20	-0.0138	0.0040
0.30	-0.1052	0.0040
0.40	-0.1724	-0.1466
0.50	-0.2598	0.0040
0.60	-0.2053	-0.3036
0.70	-0.3449	0.0040
0.80	-0.3812	-0.3269
0.90	0.0040	0.0040
0.95	-0.3427	-0.2664

Table E1. Continued.

	$x/c_R = .2$		$x/c_R = .4$		$x/c_R = .6$		$x/c_R = .8$		$x/c_R = .95$	
η	$C_{p,u}$	$C_{p,u}$	$C_{p,u}$	$C_{p,u}$	$C_{p,u}$	$C_{p,u}$	$C_{p,u}$	$C_{p,u}$	$C_{p,u}$	$C_{p,u}$
0.050	-0.1133	-0.0882	0.0630	0.0630	*****	*****	*****	*****	*****	*****
0.100	-0.1087	-0.0864	0.0530	0.0530	*****	*****	*****	*****	*****	*****
0.150	-0.1165	-0.0887	0.0421	0.0421	*****	*****	*****	*****	*****	*****
0.200	-0.1158	-0.0852	0.0252	0.0252	*****	*****	*****	*****	*****	-0.2901
0.250	*****	-0.0887	0.0108	-0.1968	-0.1968	-0.2746	*****	*****	*****	-0.2746
0.300	-0.1302	-0.0942	-0.0011	-0.1794	-0.1794	-0.2648	*****	*****	*****	-0.2648
0.350	*****	-0.0974	-0.0149	-0.1717	-0.1717	-0.2745	*****	*****	*****	-0.2745
0.400	-0.1527	-0.1039	-0.0254	-0.1618	-0.1618	-0.2958	*****	*****	*****	-0.2958
0.450	-0.1690	-0.1082	-0.0361	-0.1589	-0.1589	-0.3152	*****	*****	*****	-0.3152
0.500	-0.1835	-0.1164	-0.0497	-0.1563	-0.1563	-0.3338	*****	*****	*****	-0.3338
0.525	*****	-0.1221	-0.0562	-0.1568	-0.1568	-0.3447	*****	*****	*****	-0.3447
0.550	-0.1955	-0.1307	-0.0635	-0.1592	-0.1592	-0.3497	*****	*****	*****	-0.3497
0.575	*****	-0.1373	-0.0674	-0.1620	-0.1620	-0.3571	*****	*****	*****	-0.3571
0.600	-0.2129	-0.1435	-0.0801	-0.1592	-0.1592	-0.3632	*****	*****	*****	-0.3632
0.625	*****	*****	-0.0862	-0.1625	-0.1625	-0.3678	*****	*****	*****	-0.3678
0.650	-0.2287	-0.1642	-0.0964	-0.1688	-0.1688	-0.3674	*****	*****	*****	-0.3674
0.675	*****	-0.1812	-0.1057	-0.1726	-0.1726	-0.3611	*****	*****	*****	-0.3611
0.700	-0.2432	-0.1988	-0.1187	-0.1796	-0.1796	-0.3505	*****	*****	*****	-0.3505
0.725	*****	-0.2186	*****	-0.1894	-0.1894	-0.3220	*****	*****	*****	-0.3220
0.750	-0.2511	-0.2396	*****	-0.1981	-0.1981	-0.2609	*****	*****	*****	-0.2609
0.775	*****	-0.2639	-0.1772	-0.2131	-0.2131	-0.2058	*****	*****	*****	-0.2058
0.800	-0.2562	-0.2885	-0.2067	-0.2303	-0.2303	*****	*****	*****	*****	*****
0.825	*****	-0.3117	-0.2433	-0.2496	-0.2496	-0.2238	*****	*****	*****	-0.2238
0.850	-0.2565	-0.3345	-0.2889	-0.2908	-0.2908	-0.2359	*****	*****	*****	-0.2359
0.875	*****	-0.3534	-0.3304	-0.3390	-0.3390	-0.3041	*****	*****	*****	-0.3041
0.900	-0.2560	-0.3695	-0.3740	-0.4002	-0.4002	-0.5371	*****	*****	*****	-0.5371
0.925	*****	-0.3854	-0.4121	-0.4570	-0.4570	-0.7317	*****	*****	*****	-0.7317
0.950	-0.2591	-0.3954	-0.4535	-0.5142	-0.5142	-0.6564	*****	*****	*****	-0.6564
0.975	*****	-0.4357	-0.4924	-0.5619	-0.5619	-0.6379	*****	*****	*****	-0.6379
1.000	-0.1281	-0.3760	-0.4027	-0.6750	-0.6750	-0.5746	*****	*****	*****	-0.5746
-0.200	$C_{p,l}$	$C_{p,l}$	$C_{p,l}$	$C_{p,l}$	$C_{p,l}$	$C_{p,l}$	$C_{p,l}$	$C_{p,l}$	$C_{p,l}$	$C_{p,l}$
-0.400	0.0781	0.0895	0.1528	*****	*****	-0.3935	*****	*****	*****	-0.3935
-0.600	0.0693	0.0945	0.1158	-0.0311	-0.0311	-0.5712	*****	*****	*****	-0.5712
-0.700	0.0738	0.0887	0.1012	-0.0085	-0.0085	-0.6953	*****	*****	*****	-0.6953
-0.800	0.0909	0.0830	0.0977	0.0063	0.0063	-0.7083	*****	*****	*****	-0.7083
-0.850	0.1224	0.0914	0.0928	0.0196	0.0196	-0.6493	*****	*****	*****	-0.6493
-0.900	0.1473	0.1114	0.0961	0.0234	0.0234	-0.6613	*****	*****	*****	-0.6613
-0.950	*****	0.1429	0.1200	0.0402	0.0402	-0.6698	*****	*****	*****	-0.6698
-0.975	0.2107	0.1894	0.1706	0.0979	0.0979	-0.2628	*****	*****	*****	-0.2628
-1.000	*****	0.2074	0.1957	0.1411	0.1411	-0.0804	*****	*****	*****	-0.0804
-1.000	-0.1102	-0.3430	-0.5758	-0.6047	-0.6047	-0.4669	*****	*****	*****	-0.4669

Medium Radius L.E.

Run No. = 7, Point No. = 133

 $C_N = 0.205$, $C_m = -0.0377$ $\alpha = 5.2^\circ$, $M_\infty = 0.849$ $R_{mac} = 6.0 \times 10^6$

Leading Edge Pressures

- starboard
- port

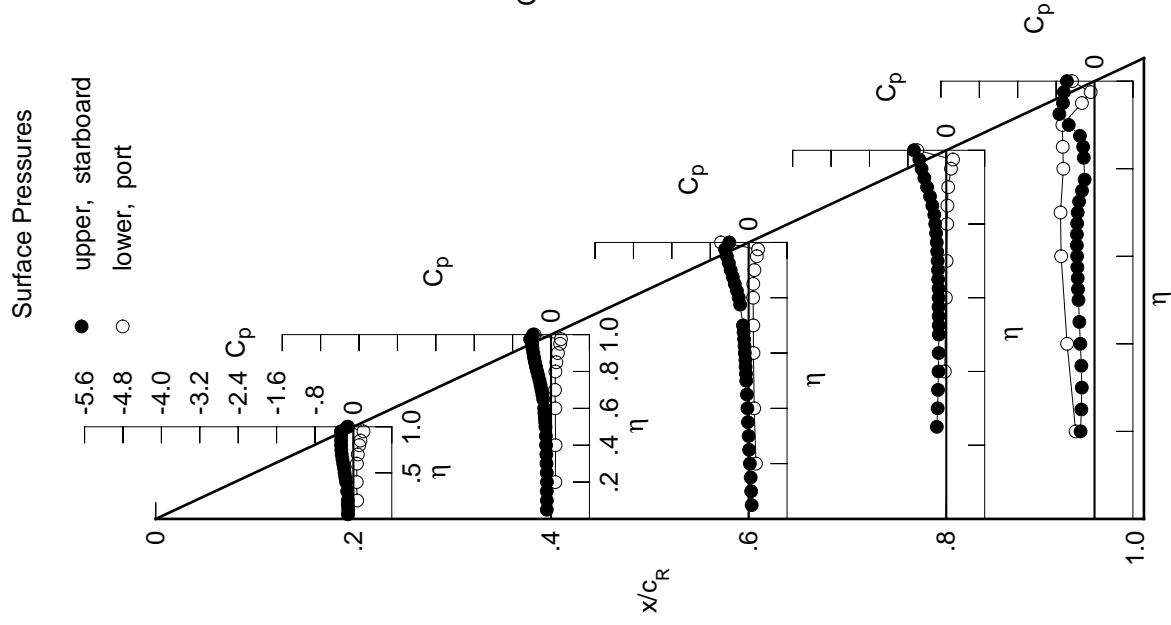
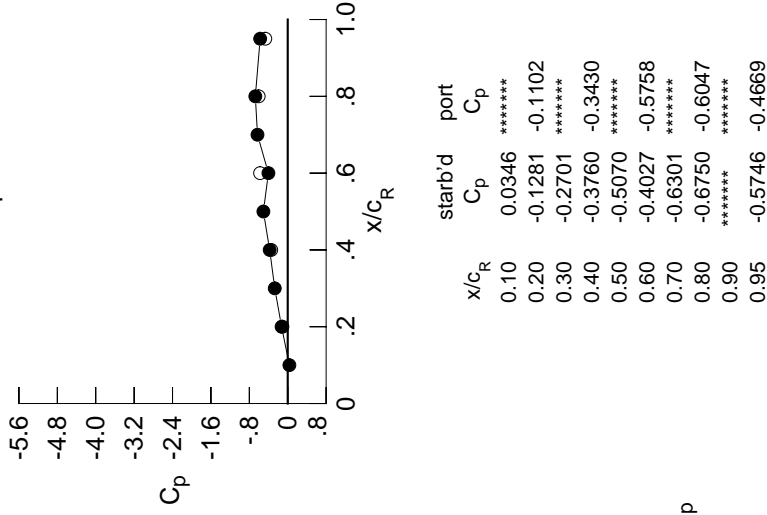
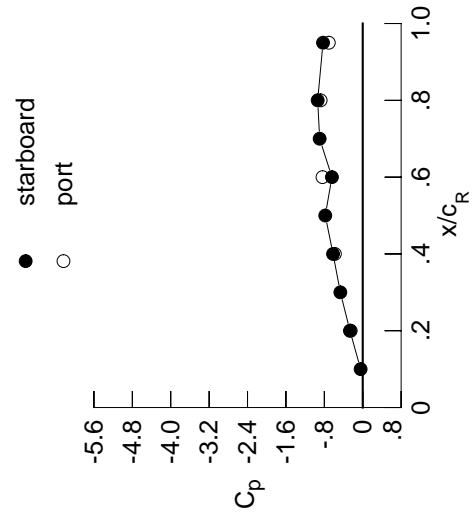

Table E1. Continued.

η	$x/c_R = .2$		$x/c_R = .4$		$x/c_R = .6$		$x/c_R = .8$		$x/c_R = .95$	
	$C_{p,u}$	$C_{p,u}$	$C_{p,u}$	$C_{p,u}$	$C_{p,u}$	$C_{p,u}$	$C_{p,u}$	$C_{p,u}$	$C_{p,u}$	$C_{p,u}$
0.050	-0.1299	-0.1034	0.0498	*****	*****	*****	*****	*****	*****	
0.100	-0.1281	-0.1019	0.0409	*****	*****	*****	*****	*****	*****	
0.150	-0.1329	-0.1050	0.0300	*****	*****	*****	*****	*****	*****	
0.200	-0.1376	-0.1034	0.0126	*****	*****	*****	*****	*****	-0.2891	
0.250	*****	-0.1069	-0.0011	-0.2077	-0.2671	*****	*****	*****	*****	
0.300	-0.1514	-0.1140	-0.0141	-0.1930	-0.2592	*****	*****	*****	*****	
0.350	*****	-0.1163	-0.0286	-0.1820	-0.2635	*****	*****	*****	*****	
0.400	-0.1764	-0.1223	-0.0404	-0.1771	-0.2906	*****	*****	*****	*****	
0.450	-0.1930	-0.1302	-0.0526	-0.1706	-0.3179	*****	*****	*****	*****	
0.500	-0.2092	-0.1383	-0.0663	-0.1708	-0.3409	*****	*****	*****	*****	
0.525	*****	-0.1464	-0.0736	-0.1712	-0.3608	*****	*****	*****	*****	
0.550	-0.2240	-0.1528	-0.0832	-0.1772	-0.3725	*****	*****	*****	*****	
0.575	*****	-0.1630	-0.0874	-0.1766	-0.3921	*****	*****	*****	*****	
0.600	-0.2449	-0.1702	-0.1026	-0.1775	-0.4042	*****	*****	*****	*****	
0.625	*****	*****	-0.1100	-0.1834	-0.4130	*****	*****	*****	*****	
0.650	-0.2629	-0.1946	-0.1209	-0.1887	-0.4177	*****	*****	*****	*****	
0.675	*****	-0.2122	-0.1349	-0.1976	-0.4182	*****	*****	*****	*****	
0.700	-0.2815	-0.2316	-0.1504	-0.2095	-0.4188	*****	*****	*****	*****	
0.725	*****	-0.2534	*****	-0.2210	-0.4093	*****	*****	*****	*****	
0.750	-0.2951	-0.2776	*****	-0.2338	-0.3797	*****	*****	*****	*****	
0.775	*****	-0.3054	-0.2107	-0.2562	-0.3307	*****	*****	*****	*****	
0.800	-0.3055	-0.3352	-0.2451	-0.2730	*****	*****	*****	*****	*****	
0.825	*****	-0.3669	-0.2814	-0.2929	-0.3122	*****	*****	*****	*****	
0.850	-0.3136	-0.3910	-0.3336	-0.3298	-0.2914	*****	*****	*****	*****	
0.875	*****	-0.4226	-0.3842	-0.3768	-0.2794	*****	*****	*****	*****	
0.900	-0.3235	-0.4468	-0.4424	-0.4463	-0.2941	*****	*****	*****	*****	
0.925	*****	-0.4736	-0.4975	-0.5180	-0.3092	*****	*****	*****	*****	
0.950	-0.3454	-0.4901	-0.5632	-0.5984	-0.6184	*****	*****	*****	*****	
0.975	*****	-0.5768	-0.6266	-0.6954	-0.7421	*****	*****	*****	*****	
1.000	-0.2661	-0.6181	-0.6415	-0.9384	-0.8276	*****	*****	*****	*****	
-0.200	$C_{p,l}$	$C_{p,l}$	$C_{p,l}$	$C_{p,l}$	$C_{p,l}$	$C_{p,l}$	$C_{p,l}$	$C_{p,l}$	$C_{p,l}$	
-0.400	0.0998	0.1084	0.1648	*****	*****	-0.4208	*****	*****	*****	
-0.600	0.0925	0.1118	0.1323	-0.0182	-0.6025	*****	*****	*****	*****	
-0.700	0.1009	0.1113	0.1198	0.0070	-0.6984	*****	*****	*****	*****	
-0.800	0.1189	0.1076	0.1186	0.0223	-0.6962	*****	*****	*****	*****	
-0.850	0.1516	0.1195	0.1159	0.0377	-0.6372	*****	*****	*****	*****	
-0.900	0.1743	0.1409	0.1225	0.0449	-0.6463	*****	*****	*****	*****	
-0.950	*****	0.1712	0.1467	0.0660	-0.6421	*****	*****	*****	*****	
-0.975	0.2235	0.2081	0.1911	0.1206	-0.2478	*****	*****	*****	*****	
-1.000	*****	0.2075	0.1984	0.1498	-0.0718	*****	*****	*****	*****	
	-0.2501	-0.5808	-0.8383	-0.8768	-0.7067	*****	*****	*****	*****	

Medium Radius L.E.
 Run No. = 7, Point No. = 134
 $C_N = 0.249$, $C_m = -0.0457$
 $\alpha = 6.2^\circ$, $M_\infty = 0.849$
 $R_{mac} = 6.0 \times 10^6$

Leading Edge Pressures



x/c_R	starb'd C_p	port C_p
0.10	-0.0438	*****
0.20	-0.2661	-0.2501
0.30	-0.4664	*****
0.40	-0.6181	-0.5808
0.50	-0.7806	*****
0.60	-0.6415	-0.8383
0.70	-0.8973	*****
0.80	-0.9384	-0.8768
0.90	*****	*****
0.95	-0.8276	-0.7067

Surface Pressures

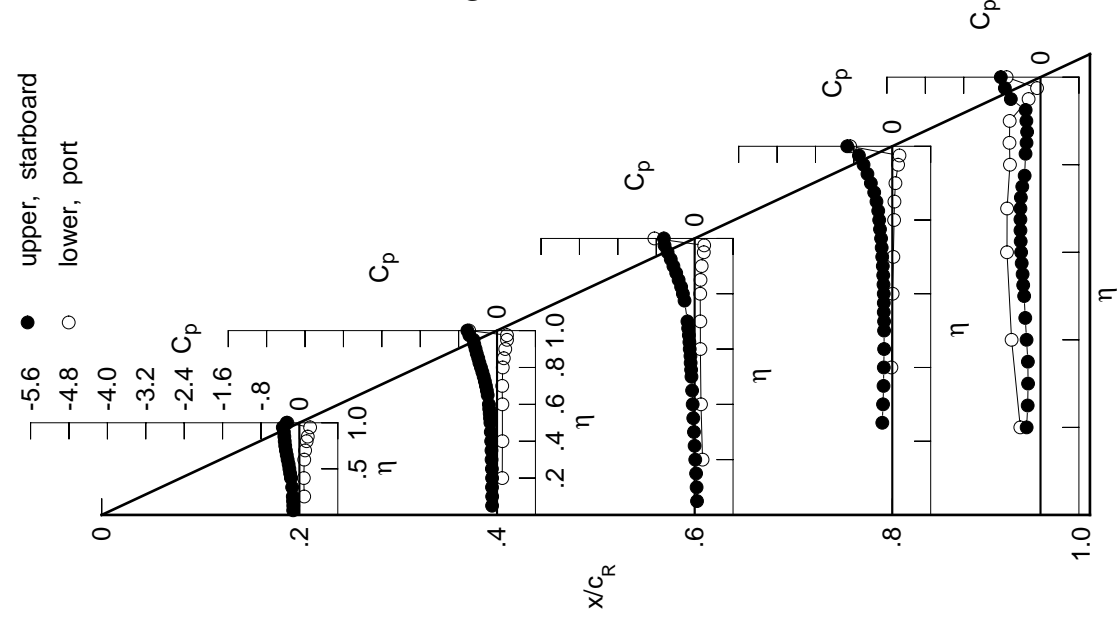
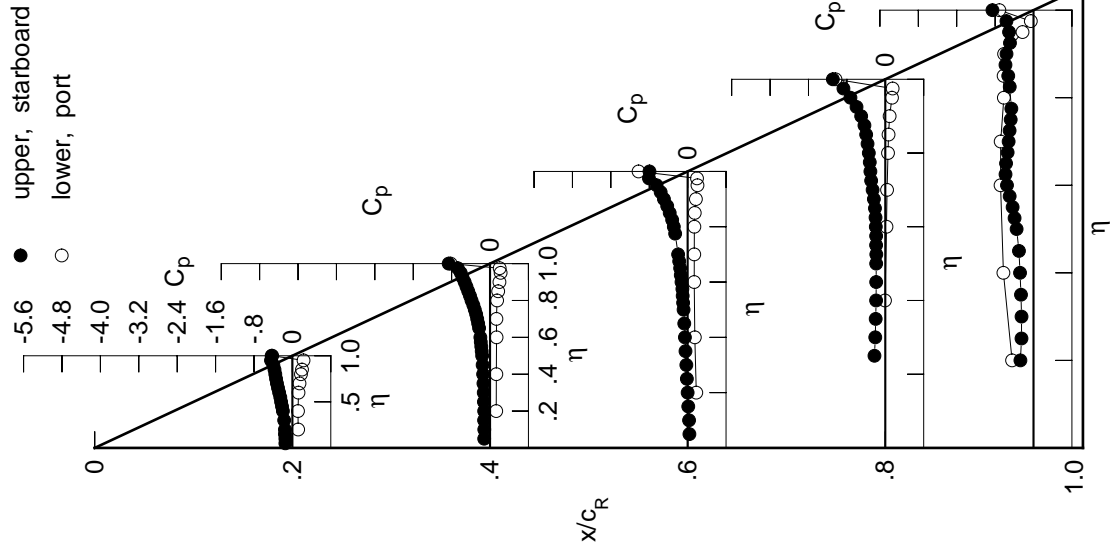

Table E1. Continued.

η	$x/c_R = .2$		$x/c_R = .4$		$x/c_R = .6$		$x/c_R = .8$		$x/c_R = .95$	
	$C_{p,u}$	$C_{p,d}$	$C_{p,u}$	$C_{p,d}$	$C_{p,u}$	$C_{p,d}$	$C_{p,u}$	$C_{p,d}$	$C_{p,u}$	$C_{p,d}$
0.050	-0.1467	-0.1219	0.0369	*****	*****	*****	*****	*****	*****	*****
0.100	-0.1464	-0.1201	0.0293	*****	*****	*****	*****	*****	*****	*****
0.150	-0.1549	-0.1243	0.0127	*****	*****	*****	*****	*****	*****	*****
0.200	-0.1553	-0.1224	0.0000	*****	*****	*****	*****	*****	*****	*****
0.250	*****	-0.1270	-0.0157	-0.2253	-0.2500	*****	*****	*****	*****	*****
0.300	-0.1714	-0.1316	-0.0271	-0.2085	-0.2494	*****	*****	*****	*****	*****
0.350	*****	-0.1375	-0.0446	-0.2000	-0.2612	*****	*****	*****	*****	*****
0.400	-0.1975	-0.1443	-0.0564	-0.1913	-0.2808	*****	*****	*****	*****	*****
0.450	-0.2164	-0.1542	-0.0702	-0.1899	-0.3035	*****	*****	*****	*****	*****
0.500	-0.2351	-0.1640	-0.0848	-0.1893	-0.3519	*****	*****	*****	*****	*****
0.525	*****	-0.1737	-0.0945	-0.1869	-0.3947	*****	*****	*****	*****	*****
0.550	-0.2519	-0.1823	-0.1036	-0.1910	-0.4352	*****	*****	*****	*****	*****
0.575	*****	-0.1931	-0.1099	-0.1907	-0.4965	*****	*****	*****	*****	*****
0.600	-0.2762	-0.2016	-0.1281	-0.1973	-0.5530	*****	*****	*****	*****	*****
0.625	*****	*****	-0.1428	-0.2032	-0.5831	*****	*****	*****	*****	*****
0.650	-0.2991	-0.2282	-0.1561	-0.2155	-0.5717	*****	*****	*****	*****	*****
0.675	*****	-0.2475	-0.1760	-0.2380	-0.5395	*****	*****	*****	*****	*****
0.700	-0.3216	-0.2675	-0.1983	-0.2644	-0.5184	*****	*****	*****	*****	*****
0.725	*****	-0.2889	*****	-0.2945	-0.4985	*****	*****	*****	*****	*****
0.750	-0.3397	-0.3176	*****	-0.3104	-0.4749	*****	*****	*****	*****	*****
0.775	*****	-0.3477	-0.2603	-0.3232	-0.4617	*****	*****	*****	*****	*****
0.800	-0.3559	-0.3856	-0.2884	-0.3429	*****	*****	*****	*****	*****	*****
0.825	*****	-0.4174	-0.3222	-0.3693	-0.4952	*****	*****	*****	*****	*****
0.850	-0.3727	-0.4546	-0.3733	-0.3983	-0.5268	*****	*****	*****	*****	*****
0.875	*****	-0.4910	-0.4253	-0.4346	-0.5837	*****	*****	*****	*****	*****
0.900	-0.3965	-0.5291	-0.4936	-0.5020	-0.5624	*****	*****	*****	*****	*****
0.925	*****	-0.5724	-0.5617	-0.5992	-0.4906	*****	*****	*****	*****	*****
0.950	-0.4459	-0.6106	-0.6465	-0.7252	-0.5100	*****	*****	*****	*****	*****
0.975	*****	-0.6717	-0.8056	-0.8722	-0.5641	*****	*****	*****	*****	*****
1.000	-0.4320	-0.8613	-0.7952	-1.0928	-0.8550	*****	*****	*****	*****	*****

Surface Pressures



Medium Radius L.E.
 Run No. = 7, Point No. = 135
 $C_N = 0.301$, $C_m = -0.0576$
 $\alpha = 7.3^\circ$, $M_\infty = 0.850$
 $R_{mac} = 6.0 \times 10^6$

Leading Edge Pressures

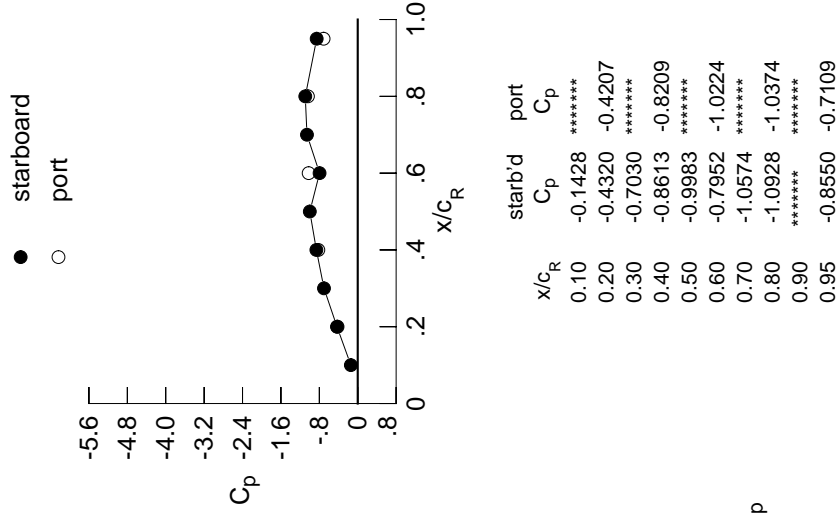

x/c_R	starb'd C_p	port C_p
0.10	-0.1428	*****
0.20	-0.4320	-0.4207
0.30	-0.7030	*****
0.40	-0.8613	-0.8209
0.50	-0.9983	*****
0.60	-0.7952	-1.0224
0.70	-1.0574	*****
0.80	-1.0928	-1.0374
0.90	*****	*****
0.95	-0.8550	-0.7109

Table E1. Continued.

η	$x/c_R = .2$		$x/c_R = .4$		$x/c_R = .6$		$x/c_R = .8$		$x/c_R = .95$	
	$C_{p,u}$	$C_{p,d}$	$C_{p,u}$	$C_{p,d}$	$C_{p,u}$	$C_{p,d}$	$C_{p,u}$	$C_{p,d}$	$C_{p,u}$	$C_{p,d}$
0.050	-0.1626	-0.1380	0.0218	*****	*****	*****	*****	*****		
0.100	-0.1629	-0.1389	0.0142	*****	*****	*****	*****	*****		
0.150	-0.1707	-0.1409	-0.0010	*****	*****	*****	*****	*****		
0.200	-0.1758	-0.1413	-0.0147	*****	*****	*****	*****	-0.2695		
0.250	*****	-0.1435	-0.0336	-0.2483	-0.2492	*****	*****	-0.2492		
0.300	-0.1900	-0.1517	-0.0458	-0.2299	-0.2424	*****	*****	-0.2424		
0.350	*****	-0.1577	-0.0606	-0.2217	-0.2523	*****	*****	-0.2523		
0.400	-0.2206	-0.1660	-0.0753	-0.2135	-0.2836	*****	*****	-0.2836		
0.450	-0.2391	-0.1780	-0.0855	-0.2095	-0.3200	*****	*****	-0.3200		
0.500	-0.2592	-0.1915	-0.1056	-0.2059	-0.3242	*****	*****	-0.3242		
0.525	*****	-0.2012	-0.1150	-0.2079	-0.2852	*****	*****	-0.2852		
0.550	-0.2796	-0.2132	-0.1314	-0.2230	-0.1808	*****	*****	-0.1808		
0.575	*****	-0.2242	-0.1438	-0.2431	-0.1570	*****	*****	-0.1570		
0.600	-0.3063	-0.2365	-0.1723	-0.2670	-0.1950	*****	*****	-0.1950		
0.625	*****	*****	*****	-0.1910	-0.2615	-0.2604	*****	-0.2604		
0.650	-0.3349	-0.2686	-0.2164	-0.2406	-0.3335	*****	*****	-0.3335		
0.675	*****	-0.2845	-0.2389	-0.2356	-0.4425	*****	*****	-0.4425		
0.700	-0.3613	-0.3059	-0.2582	-0.2308	-0.5924	*****	*****	-0.5924		
0.725	*****	-0.3284	*****	-0.2243	-0.6618	*****	*****	-0.6618		
0.750	-0.3866	-0.3556	*****	-0.2132	-0.6799	*****	*****	-0.6799		
0.775	*****	-0.3902	-0.2942	-0.1943	-0.8357	*****	*****	-0.8357		
0.800	-0.4099	-0.4279	-0.3130	-0.3595	*****	*****	*****	*****		
0.825	*****	-0.4683	-0.3446	-0.7858	-0.9678	*****	*****	-0.9678		
0.850	-0.4367	-0.5096	-0.4060	-0.8823	-0.8834	*****	*****	-0.8834		
0.875	*****	-0.5575	-0.5491	-0.8541	-0.7645	*****	*****	-0.7645		
0.900	-0.4584	-0.6033	-0.7720	-0.8186	-0.7049	*****	*****	-0.7049		
0.925	*****	-0.6584	-0.9073	-0.7684	-0.6904	*****	*****	-0.6904		
0.950	-0.5451	-0.7038	-0.9539	-0.7388	-0.6088	*****	*****	-0.6088		
0.975	*****	-1.0094	-0.9531	-0.7331	-0.5814	*****	*****	-0.5814		
1.000	-0.6202	-1.0453	-0.8279	-0.8678	-0.5993	*****	*****	-0.5993		

Surface Pressures

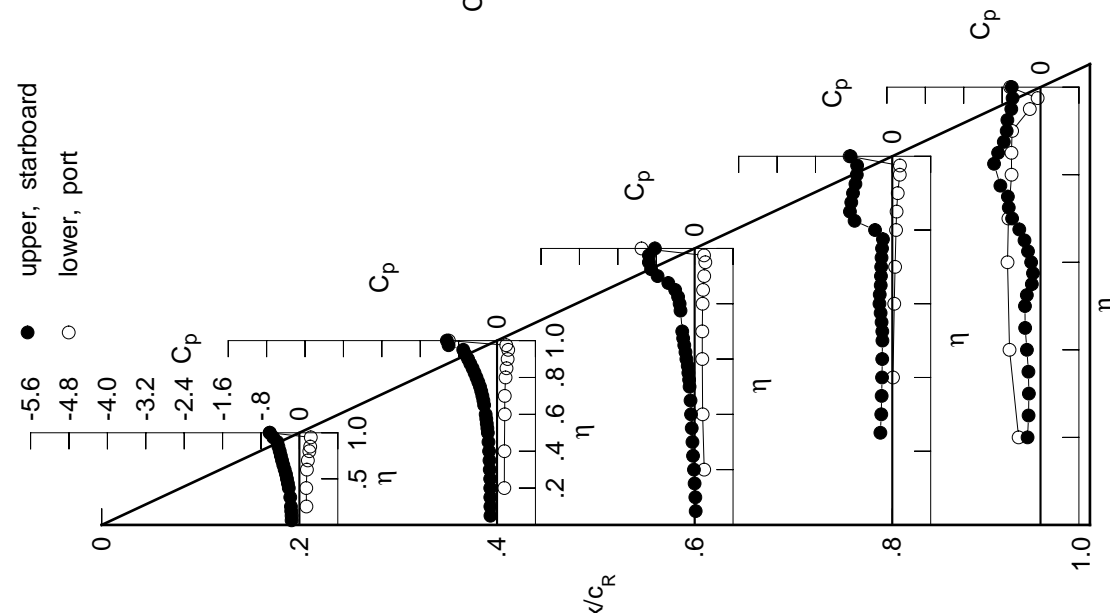

Medium Radius L.E.
Run No. = 7, Point No. = 136
 $C_N = 0.362$, $C_m = -0.0716$
 $\alpha = 8.3^\circ$, $M_\infty = 0.850$
 $R_{mac} = 6.0 \times 10^6$

Leading Edge Pressures

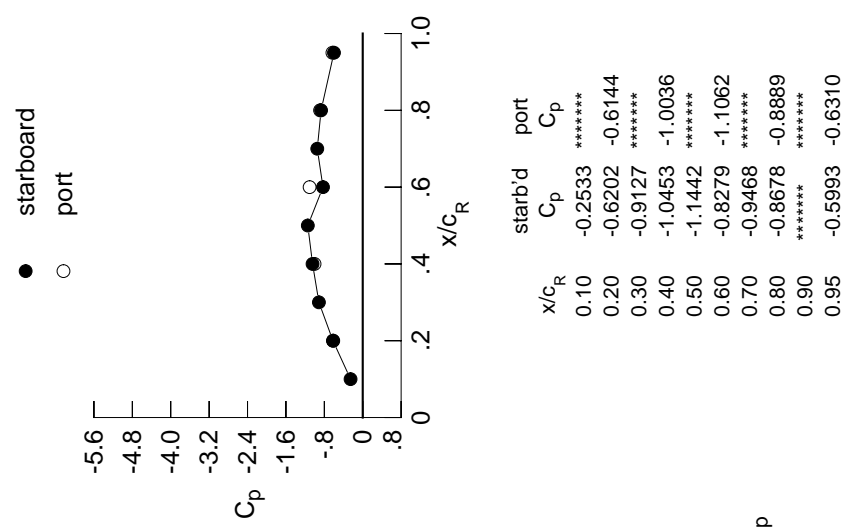

x/c_R	starb'd C_p	port C_p
0.10	-0.2533	*****
0.20	-0.6202	-0.6144
0.30	-0.9127	*****
0.40	-1.0453	-1.0036
0.50	-1.1442	*****
0.60	-0.8279	-1.1062
0.70	-0.9468	*****
0.80	-0.8678	-0.8889
0.90	*****	*****
0.95	-0.5993	-0.6310

Table E1. Continued.

η	$x/c_R = .2$		$x/c_R = .4$		$x/c_R = .6$		$x/c_R = .8$		$x/c_R = .95$	
	$C_{p,u}$	$C_{p,u}$	$C_{p,u}$	$C_{p,u}$	$C_{p,u}$	$C_{p,u}$	$C_{p,u}$	$C_{p,u}$	$C_{p,u}$	$C_{p,u}$
0.050	-0.1825	-0.1613	0.0039	*****	*****	*****	*****	*****	*****	
0.100	-0.1824	-0.1605	-0.0052	*****	*****	*****	*****	*****	*****	
0.150	-0.1913	-0.1647	-0.0206	*****	*****	*****	*****	*****	*****	
0.200	-0.1941	-0.1623	-0.0359	*****	*****	*****	*****	*****	-0.2940	
0.250	*****	-0.1681	-0.0523	-0.2754	-0.2498	*****	*****	*****	*****	
0.300	-0.2112	-0.1764	-0.0655	-0.2555	-0.2269	*****	*****	*****	*****	
0.350	*****	-0.1834	-0.0811	-0.2450	-0.2563	*****	*****	*****	*****	
0.400	-0.2426	-0.1958	-0.0954	-0.2344	-0.3053	*****	*****	*****	*****	
0.450	-0.2653	-0.2080	-0.1058	-0.2425	-0.2164	*****	*****	*****	*****	
0.500	-0.2860	-0.2295	-0.1396	-0.2670	-0.2176	*****	*****	*****	*****	
0.525	*****	-0.2423	-0.1654	-0.2471	-0.2655	*****	*****	*****	*****	
0.550	-0.3094	-0.2593	-0.1970	-0.2392	-0.3145	*****	*****	*****	*****	
0.575	*****	-0.2744	-0.2102	-0.2346	-0.3900	*****	*****	*****	*****	
0.600	-0.3387	-0.2865	-0.2114	-0.2284	-0.4877	*****	*****	*****	*****	
0.625	*****	*****	-0.2011	-0.2273	-0.5932	*****	*****	*****	*****	
0.650	-0.3704	-0.3199	-0.1983	-0.2209	-0.6300	*****	*****	*****	*****	
0.675	*****	-0.3362	-0.1979	-0.2106	-0.6147	*****	*****	*****	*****	
0.700	-0.4028	-0.3558	-0.2011	-0.1986	-0.6234	*****	*****	*****	*****	
0.725	*****	-0.3760	*****	-0.2176	-0.7262	*****	*****	*****	*****	
0.750	-0.4325	-0.4042	*****	-0.4138	-0.8631	*****	*****	*****	*****	
0.775	*****	-0.4360	-0.1896	-0.7843	-0.9134	*****	*****	*****	*****	
0.800	-0.4650	-0.4739	-0.5636	-0.9593	*****	*****	*****	*****	*****	
0.825	*****	-0.5138	-0.9281	-1.0034	-0.7127	*****	*****	*****	*****	
0.850	-0.4996	-0.5609	-0.9947	-0.9299	-0.6329	*****	*****	*****	*****	
0.875	*****	-0.6285	-0.9843	-0.7943	-0.6230	*****	*****	*****	*****	
0.900	-0.5415	-0.7241	-0.9442	-0.7426	-0.6332	*****	*****	*****	*****	
0.925	*****	-0.8685	-0.8930	-0.7106	-0.6672	*****	*****	*****	*****	
0.950	-0.6069	-1.0257	-0.8614	-0.7099	-0.5963	*****	*****	*****	*****	
0.975	*****	-1.1751	-0.8442	-0.6917	-0.5497	*****	*****	*****	*****	
1.000	-0.7941	-1.1633	-0.7709	-0.7811	-0.5412	*****	*****	*****	*****	
-0.200	$C_{p,l}$	$C_{p,l}$	$C_{p,l}$	$C_{p,l}$	$C_{p,l}$	$C_{p,l}$	$C_{p,l}$	$C_{p,l}$	$C_{p,l}$	
-0.400	0.1692	0.1733	0.2146	*****	-0.4927	*****	*****	*****	*****	
-0.600	0.1701	0.1769	0.1850	0.0267	-0.6801	*****	*****	*****	*****	
-0.700	0.1834	0.1824	0.1776	0.0542	-0.6768	*****	*****	*****	*****	
-0.800	0.2045	0.1863	0.1796	0.0717	-0.6585	*****	*****	*****	*****	
-0.850	0.2321	0.2047	0.1869	0.0939	-0.5901	*****	*****	*****	*****	
-0.900	0.2479	0.2238	0.1979	0.1065	-0.5910	*****	*****	*****	*****	
-0.950	*****	0.2423	0.2184	0.1304	-0.5717	*****	*****	*****	*****	
-0.975	0.2389	0.2402	0.2323	0.1665	-0.2131	*****	*****	*****	*****	
-1.000	*****	0.1791	0.1924	0.1581	-0.0568	*****	*****	*****	*****	
	-0.8132	-1.1212	-1.0026	-0.7933	-0.5715	*****	*****	*****	*****	

Medium Radius L.E.

Run No. = 7, Point No. = 137

$C_N = 0.420$, $C_m = -0.0834$

$\alpha = 9.3^\circ$, $M_\infty = 0.851$

$R_{mac} = 6.0 \times 10^6$

Leading Edge Pressures

● starboard
○ port

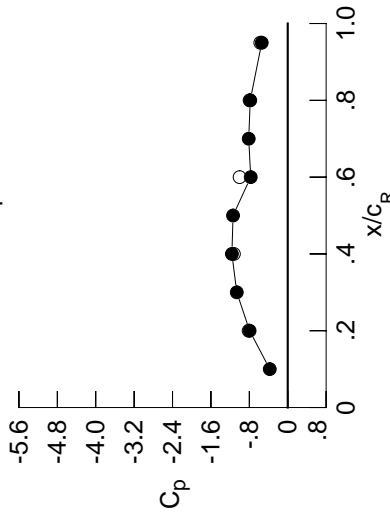

x/c_R	starb'd C_p	port C_p
0.10	-0.3741	*****
0.20	-0.7941	-0.8132
0.30	-1.0612	*****
0.40	-1.1633	-1.1212
0.50	-1.1390	*****
0.60	-0.7709	-1.0026
0.70	-0.8128	*****
0.80	-0.7811	-0.7933
0.90	*****	*****
0.95	-0.5412	-0.5715

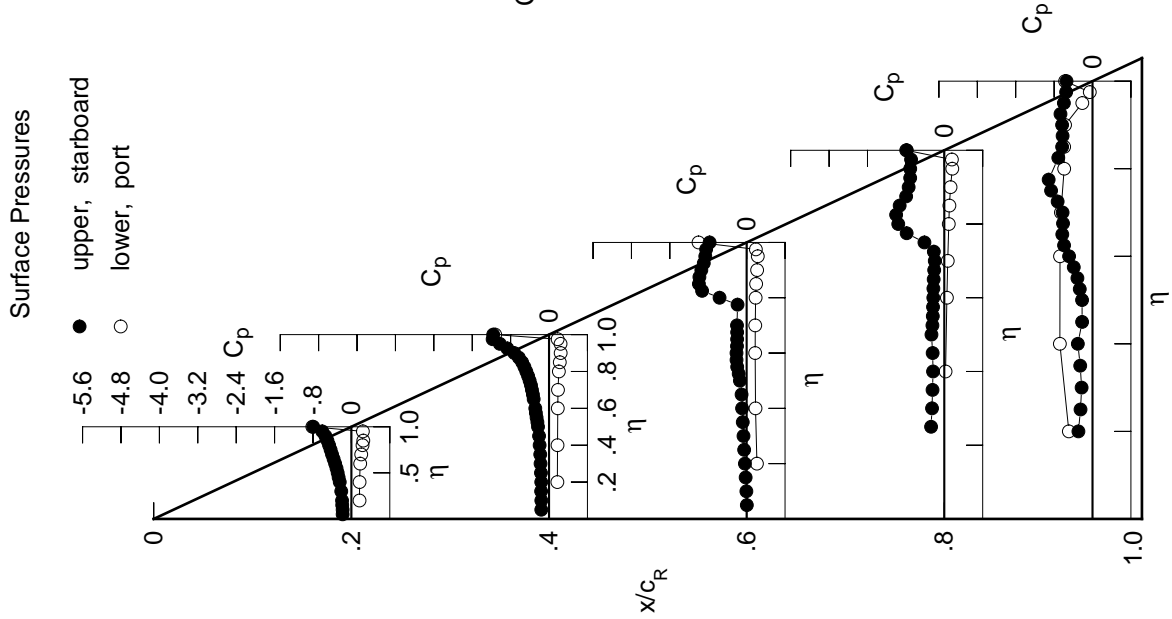
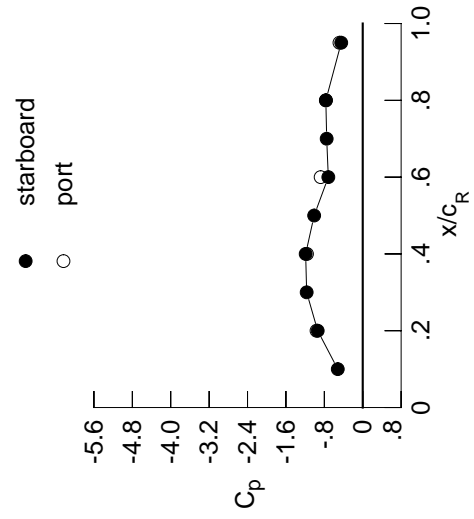

Table E1. Continued.

η	$x/c_R = 0.2$		$x/c_R = 0.4$		$x/c_R = 0.6$		$x/c_R = 0.8$		$x/c_R = 0.95$	
	$C_{p,u}$	$C_{p,l}$	$C_{p,u}$	$C_{p,l}$	$C_{p,u}$	$C_{p,l}$	$C_{p,u}$	$C_{p,l}$	$C_{p,u}$	$C_{p,l}$
0.050	-0.1981	-0.1844	-0.0159	*****	*****	*****	*****	*****	*****	*****
0.100	-0.2006	-0.1855	-0.0263	*****	*****	*****	*****	*****	*****	*****
0.150	-0.2074	-0.1867	-0.0407	*****	*****	*****	*****	*****	*****	*****
0.200	-0.2131	-0.1892	-0.0596	*****	*****	*****	*****	*****	*****	*****
0.250	*****	-0.1960	-0.0738	-0.2917	-0.2349	*****	*****	*****	*****	*****
0.300	-0.2327	-0.2027	-0.0867	-0.2665	-0.2655	*****	*****	*****	*****	*****
0.350	*****	-0.2094	-0.1037	-0.2635	-0.2781	*****	*****	*****	*****	*****
0.400	-0.2698	-0.2248	-0.1311	-0.2763	-0.2040	*****	*****	*****	*****	*****
0.450	-0.2892	-0.2489	-0.1732	-0.2504	-0.2652	*****	*****	*****	*****	*****
0.500	-0.3136	-0.2772	-0.1704	-0.2414	-0.3598	*****	*****	*****	*****	*****
0.525	*****	-0.2927	-0.1653	-0.2386	-0.4453	*****	*****	*****	*****	*****
0.550	-0.3398	-0.3109	-0.1687	-0.2358	-0.5228	*****	*****	*****	*****	*****
0.575	*****	-0.3166	-0.1646	-0.2289	-0.6017	*****	*****	*****	*****	*****
0.600	-0.3708	-0.3218	-0.1761	-0.2208	-0.6222	*****	*****	*****	*****	*****
0.625	*****	*****	-0.1756	-0.2115	-0.6234	*****	*****	*****	*****	*****
0.650	-0.4067	-0.3344	-0.1736	-0.2104	-0.6325	*****	*****	*****	*****	*****
0.675	*****	-0.3440	-0.1669	-0.2471	-0.6744	*****	*****	*****	*****	*****
0.700	-0.4425	-0.3600	-0.1615	-0.3907	-0.7809	*****	*****	*****	*****	*****
0.725	*****	-0.3754	*****	-0.6717	-0.8860	*****	*****	*****	*****	*****
0.750	-0.4795	-0.4012	*****	-0.9275	-0.8637	*****	*****	*****	*****	*****
0.775	*****	-0.4388	-1.0011	-1.0579	-0.7049	*****	*****	*****	*****	*****
0.800	-0.5190	-0.5579	-1.1042	-1.0422	*****	*****	*****	*****	*****	*****
0.825	*****	-0.7738	-1.0911	-0.8877	-0.5776	*****	*****	*****	*****	*****
0.850	-0.5728	-0.9503	-1.0458	-0.7835	-0.5601	*****	*****	*****	*****	*****
0.875	*****	-1.0466	-0.9720	-0.7631	-0.5637	*****	*****	*****	*****	*****
0.900	-0.6244	-1.0840	-0.8808	-0.7302	-0.5717	*****	*****	*****	*****	*****
0.925	*****	-1.0858	-0.8269	-0.6996	-0.5794	*****	*****	*****	*****	*****
0.950	-0.7016	-1.0723	-0.7927	-0.7321	-0.5110	*****	*****	*****	*****	*****
0.975	*****	-1.0692	-0.7750	-0.7111	-0.4439	*****	*****	*****	*****	*****
1.000	-0.9383	-1.1890	-0.7170	-0.7687	-0.4479	*****	*****	*****	*****	*****
-0.200	$C_{p,l}$	0.2008	0.1987	0.2355	*****	*****	*****	*****	*****	*****
-0.400	0.1988	0.2036	0.2044	0.0425	-0.6826	*****	*****	*****	*****	*****
-0.600	0.2149	0.2097	0.1990	0.0723	-0.6670	*****	*****	*****	*****	*****
-0.700	0.2345	0.2140	0.2031	0.0882	-0.6479	*****	*****	*****	*****	*****
-0.800	0.2585	0.2312	0.2089	0.1131	-0.5766	*****	*****	*****	*****	*****
-0.850	0.2701	0.2493	0.2195	0.1238	-0.5768	*****	*****	*****	*****	*****
-0.900	*****	0.2620	0.2384	0.1463	-0.5506	*****	*****	*****	*****	*****
-0.950	0.2367	0.2490	0.2405	0.1744	-0.2001	*****	*****	*****	*****	*****
-0.975	*****	0.1720	0.1876	0.1531	-0.0484	*****	*****	*****	*****	*****
-1.000	-0.9623	-1.1614	-0.8770	-0.7653	-0.4848	*****	*****	*****	*****	*****

Medium Radius L.E.
 Run No. = 7, Point No. = 138
 $C_N = 0.474$, $C_m = -0.0903$
 $\alpha = 10.4^\circ$, $M_\infty = 0.849$
 $R_{mac} = 6.0 \times 10^6$

Leading Edge Pressures



x/c_R	starb'd C_p	port C_p
0.10	-0.5197	*****
0.20	-0.9383	-0.9623
0.30	-1.1683	*****
0.40	-1.1890	-1.1614
0.50	-1.0120	*****
0.60	-0.7170	-0.8770
0.70	-0.7508	*****
0.80	-0.7687	-0.7653
0.90	*****	*****
0.95	-0.4479	-0.4848

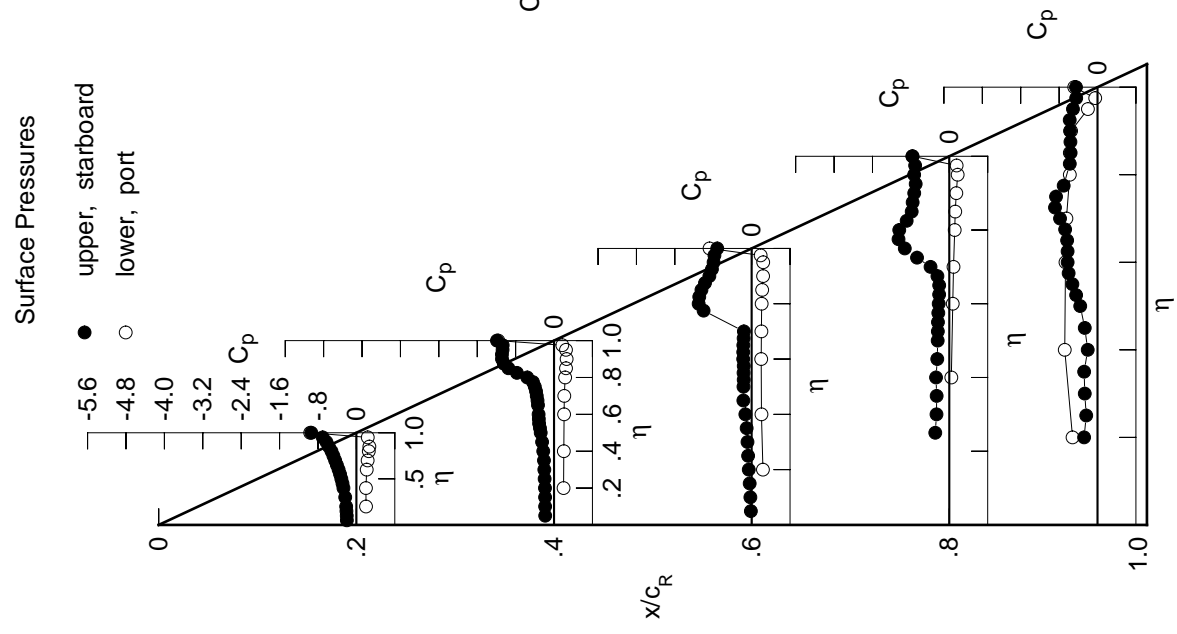

Table E1. Continued.

η	$x/c_R = .2$		$x/c_R = .4$		$x/c_R = .6$		$x/c_R = .8$		$x/c_R = .95$	
	$C_{p,u}$	$C_{p,u}$	$C_{p,u}$	$C_{p,u}$	$C_{p,u}$	$C_{p,u}$	$C_{p,u}$	$C_{p,u}$	$C_{p,u}$	$C_{p,u}$
0.050	-0.2136	-0.2085	-0.0369	*****	*****	*****	*****	*****	*****	*****
0.100	-0.2207	-0.2116	-0.0442	*****	*****	*****	*****	*****	*****	*****
0.150	-0.2293	-0.2134	-0.0648	*****	*****	*****	*****	*****	*****	*****
0.200	-0.2315	-0.2147	-0.0797	*****	*****	*****	*****	*****	*****	-0.2983
0.250	*****	-0.2190	-0.0957	-0.3087	-0.2940	-0.2732	*****	*****	*****	-0.2779
0.300	-0.2580	-0.2242	-0.1084	-0.2940	-0.2940	-0.2732	*****	*****	*****	-0.2732
0.350	*****	-0.2357	-0.1508	-0.2953	-0.1963	*****	*****	*****	*****	-0.1963
0.400	-0.2957	-0.2630	-0.1657	-0.2722	-0.2454	*****	*****	*****	*****	-0.2454
0.450	-0.3175	-0.3069	-0.1567	-0.2612	-0.3339	*****	*****	*****	*****	-0.3339
0.500	-0.3430	-0.3054	-0.1652	-0.2518	-0.4674	*****	*****	*****	*****	-0.4674
0.525	*****	-0.2993	-0.1685	-0.2480	-0.5513	*****	*****	*****	*****	-0.5513
0.550	-0.3702	-0.2993	-0.1750	-0.2440	-0.5904	*****	*****	*****	*****	-0.5904
0.575	*****	-0.2998	-0.1701	-0.2375	-0.6248	*****	*****	*****	*****	-0.6248
0.600	-0.4036	-0.2999	-0.1776	-0.2381	-0.6393	*****	*****	*****	*****	-0.6393
0.625	*****	*****	-0.1686	-0.2624	-0.6806	*****	*****	*****	*****	-0.6806
0.650	-0.4428	-0.3071	-0.1780	-0.3416	-0.7708	*****	*****	*****	*****	-0.7708
0.675	*****	-0.3071	-0.2422	-0.5201	-0.8865	*****	*****	*****	*****	-0.8865
0.700	-0.4831	-0.2898	-0.4633	-0.7723	-1.0084	*****	*****	*****	*****	-1.0084
0.725	*****	-0.2743	*****	-1.0014	-0.9560	*****	*****	*****	*****	-0.9560
0.750	-0.5256	-0.6523	*****	-1.1377	-0.6581	*****	*****	*****	*****	-0.6581
0.775	*****	-1.0327	-1.1717	-1.0825	-0.5828	*****	*****	*****	*****	-0.5828
0.800	-0.5768	-1.1332	-1.1652	-0.8586	*****	*****	*****	*****	*****	-0.8586
0.825	*****	-1.1484	-1.1257	-0.7883	-0.5575	*****	*****	*****	*****	-0.5575
0.850	-0.6317	-1.1387	-1.0242	-0.7838	-0.5445	*****	*****	*****	*****	-0.5445
0.875	*****	-1.1169	-0.9118	-0.7808	-0.5384	*****	*****	*****	*****	-0.5384
0.900	-0.7027	-1.0843	-0.8652	-0.7408	-0.5237	*****	*****	*****	*****	-0.5237
0.925	*****	-1.0547	-0.8132	-0.7306	-0.5017	*****	*****	*****	*****	-0.5017
0.950	-1.0388	-1.0329	-0.7740	-0.7539	-0.4390	*****	*****	*****	*****	-0.4390
0.975	*****	-1.0259	-0.7564	-0.7305	-0.3839	*****	*****	*****	*****	-0.3839
1.000	-1.0448	-1.1120	-0.6948	-0.7640	-0.3875	*****	*****	*****	*****	-0.3875
-0.200	$C_{p,l}$	$C_{p,l}$	$C_{p,l}$	$C_{p,l}$	$C_{p,l}$	$C_{p,l}$	$C_{p,l}$	$C_{p,l}$	$C_{p,l}$	$C_{p,l}$
-0.400	0.2291	0.2215	0.2526	*****	-0.5282	*****	*****	*****	*****	-0.5282
-0.600	0.2279	0.2283	0.2226	0.0580	0.6785	*****	*****	*****	*****	0.6785
-0.700	0.2450	0.2333	0.2188	0.0890	-0.6578	*****	*****	*****	*****	-0.6578
-0.800	0.2641	0.2400	0.2227	0.1037	-0.6384	*****	*****	*****	*****	-0.6384
-0.850	0.2865	0.2572	0.2284	0.1276	-0.5652	*****	*****	*****	*****	-0.5652
-0.900	0.2929	0.2725	0.2391	0.1392	-0.5626	*****	*****	*****	*****	-0.5626
-0.950	0.2386	0.2541	0.2445	0.1765	-0.1887	*****	*****	*****	*****	-0.1887
-0.975	*****	0.1610	0.1793	0.1458	-0.0447	*****	*****	*****	*****	-0.0447
-1.000	-1.0724	-1.1560	-0.8266	-0.7705	-0.4303	*****	*****	*****	*****	-0.4303

Medium Radius L.E.

Run No. = 7, Point No. = 139

$C_N = 0.529$, $C_m = -0.0986$

$\alpha = 11.4^\circ$, $M_\infty = 0.850$

$R_{mac} = 6.0 \times 10^6$

Leading Edge Pressures

● starboard
○ port

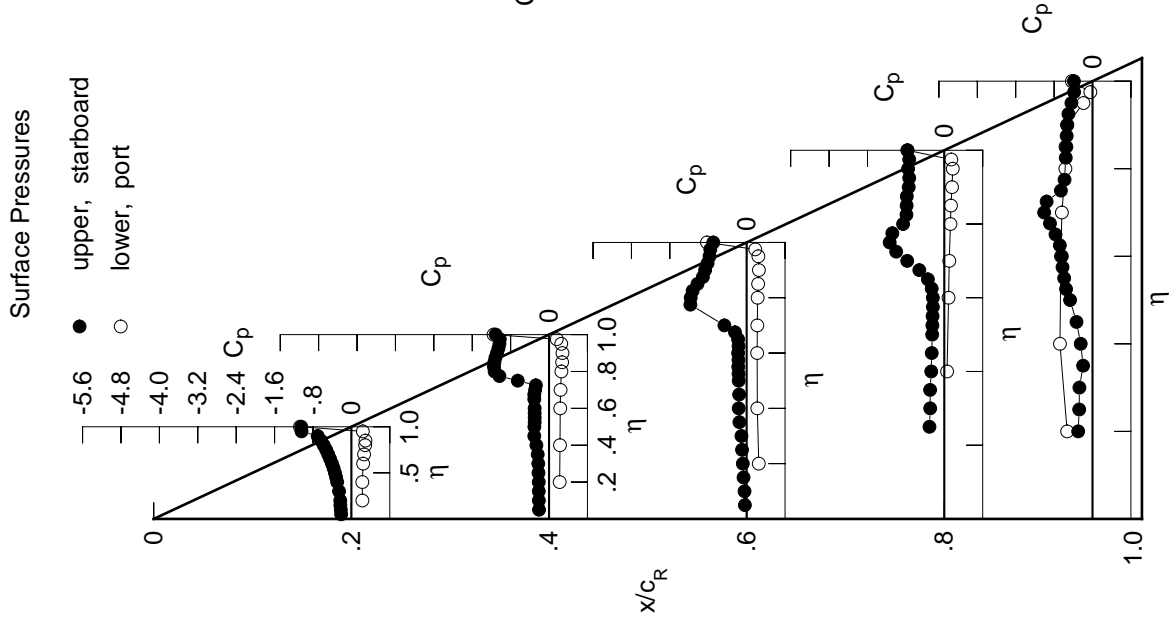
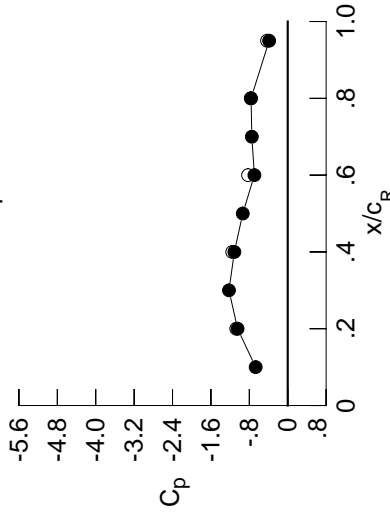

Table E1. Continued.

η	$x/c_R = .2$		$x/c_R = .4$		$x/c_R = .6$		$x/c_R = .8$		$x/c_R = .95$	
	$C_{p,u}$	$C_{p,u}$	$C_{p,u}$	$C_{p,u}$	$C_{p,u}$	$C_{p,u}$	$C_{p,u}$	$C_{p,u}$	$C_{p,u}$	$C_{p,u}$
0.050	-0.2392	-0.2459	-0.0591	*****	*****	*****	*****	*****	*****	
0.100	-0.2436	-0.2429	-0.0692	*****	*****	*****	*****	*****	*****	
0.150	-0.2544	-0.2470	-0.0846	*****	*****	*****	*****	*****	*****	
0.200	-0.2617	-0.2451	-0.1000	*****	*****	*****	*****	*****	-0.3590	
0.250	*****	-0.2579	-0.1279	-0.3423	-0.2889	*****	*****	*****	-0.2889	
0.300	-0.2915	-0.2766	-0.1544	-0.3326	-0.1467	*****	*****	*****	-0.1467	
0.350	*****	-0.3003	-0.1577	-0.3100	-0.1826	*****	*****	*****	-0.1826	
0.400	-0.3278	-0.3009	-0.1617	-0.2952	-0.2832	*****	*****	*****	-0.2832	
0.450	-0.3480	-0.2989	-0.1633	-0.2827	-0.4198	*****	*****	*****	-0.4198	
0.500	-0.3719	-0.3054	-0.1738	-0.2719	-0.5454	*****	*****	*****	-0.5454	
0.525	*****	-0.3077	-0.1739	-0.2674	-0.5928	*****	*****	*****	-0.5928	
0.550	-0.3995	-0.3097	-0.1792	-0.2700	-0.6093	*****	*****	*****	-0.6093	
0.575	*****	-0.3120	-0.1812	-0.2873	-0.6490	*****	*****	*****	-0.6490	
0.600	-0.4361	-0.3105	-0.2249	-0.3325	-0.7011	*****	*****	*****	-0.7011	
0.625	*****	*****	-0.2908	-0.4462	-0.8042	*****	*****	*****	-0.8042	
0.650	-0.4799	-0.3188	-0.4907	-0.6349	-0.9448	*****	*****	*****	-0.9448	
0.675	*****	-0.4030	-0.7534	-0.8597	-1.0740	*****	*****	*****	-1.0740	
0.700	-0.5150	-0.6927	-0.9757	-1.0483	-1.1213	*****	*****	*****	-1.1213	
0.725	*****	-0.9470	*****	-1.1669	-0.7825	*****	*****	*****	-0.7825	
0.750	-0.5603	-1.0575	*****	-1.1716	-0.6700	*****	*****	*****	-0.6700	
0.775	*****	-1.1194	-1.1299	-1.0178	-0.6082	*****	*****	*****	-0.6082	
0.800	-0.6077	-1.1615	-1.0820	-0.8812	*****	*****	*****	*****	*****	
0.825	*****	-1.1746	-1.0100	-0.8333	-0.5699	*****	*****	*****	-0.5699	
0.850	-0.8568	-1.1534	-0.9380	-0.8228	-0.5443	*****	*****	*****	-0.5443	
0.875	*****	-1.1115	-0.9000	-0.8094	-0.5269	*****	*****	*****	-0.5269	
0.900	-1.0457	-1.0688	-0.8678	-0.7737	-0.5039	*****	*****	*****	-0.5039	
0.925	*****	-1.0394	-0.8345	-0.7418	-0.4835	*****	*****	*****	-0.4835	
0.950	-1.1780	-1.0174	-0.8064	-0.7617	-0.4205	*****	*****	*****	-0.4205	
0.975	*****	-1.0036	-0.7849	-0.7392	-0.3701	*****	*****	*****	-0.3701	
1.000	-1.1200	-1.0516	-0.7203	-0.7580	-0.3604	*****	*****	*****	-0.3604	
-0.200	$C_{p,l}$	0.2542	0.2433	0.2679	*****	*****	*****	*****	-0.5573	
-0.400	$C_{p,l}$	0.2564	0.2489	0.2397	0.0722	-0.6754	*****	*****	-0.6754	
-0.600	$C_{p,l}$	0.2736	0.2548	0.2345	0.1004	-0.6556	*****	*****	-0.6556	
-0.700	$C_{p,l}$	0.2920	0.2636	0.2387	0.1157	-0.6329	*****	*****	-0.6329	
-0.800	$C_{p,l}$	0.3100	0.2800	0.2458	0.1400	-0.5582	*****	*****	-0.5582	
-0.850	$C_{p,l}$	0.3130	0.2925	0.2552	0.1531	-0.5514	*****	*****	-0.5514	
-0.900	$C_{p,l}$	*****	0.2971	0.2671	0.1732	-0.5153	*****	*****	-0.5153	
-0.950	$C_{p,l}$	0.2372	0.2563	0.2463	0.1832	-0.1817	*****	*****	-0.1817	
-0.975	$C_{p,l}$	*****	0.1493	0.1667	0.1360	-0.0453	*****	*****	-0.0453	
-1.000	$C_{p,l}$	-1.1363	-1.0824	-0.8231	-0.7930	-0.3954	*****	*****	-0.3954	

Medium Radius L.E.
 Run No. = 7, Point No. = 140
 $C_N = 0.585$, $C_m = -0.1089$
 $\alpha = 12.4^\circ$, $M_\infty = 0.849$
 $R_{mac} = 6.0 \times 10^6$

Leading Edge Pressures

● starboard
 ○ port

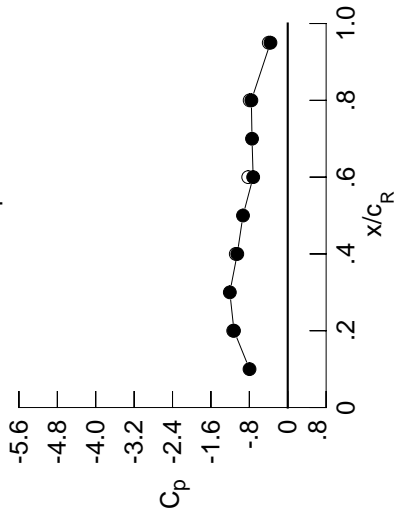

x/c_R	starb'd C_p	port C_p
0.10	-0.7956	*****
0.20	-1.1200	-1.1363
0.30	-1.2062	*****
0.40	-1.0516	-1.0824
0.50	-0.9324	*****
0.60	-0.7203	-0.8231
0.70	-0.7443	*****
0.80	-0.7580	-0.7930
0.90	*****	*****
0.95	-0.3604	-0.3954

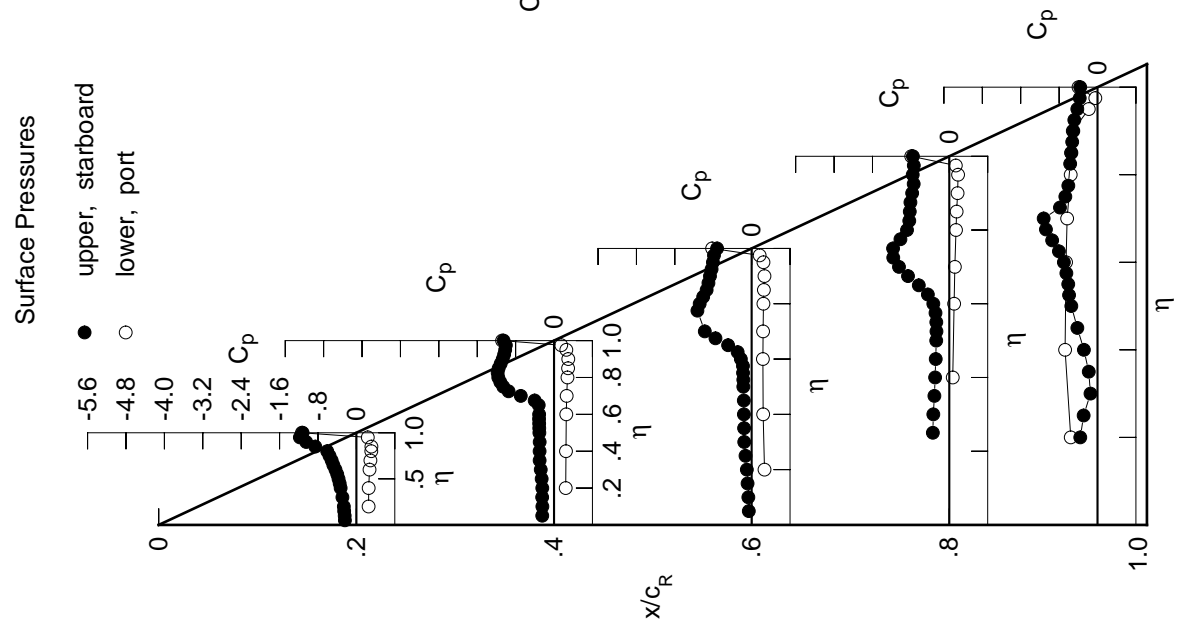

Table E1. Continued.

η	x/c_R .2	x/c_R .4	x/c_R .6	x/c_R .8	x/c_R .95
	$C_{p,u}$	$C_{p,u}$	$C_{p,u}$	$C_{p,u}$	$C_{p,u}$
0.050	-0.2599	-0.2819	-0.0787	*****	*****
0.100	-0.2611	-0.2774	-0.0860	*****	*****
0.150	-0.2804	-0.2821	-0.1040	*****	*****
0.200	-0.2889	-0.2828	-0.1275	*****	-0.3616
0.250	*****	-0.3071	-0.1583	-0.3760	-0.2539
0.300	-0.3165	-0.3254	-0.1567	-0.3468	-0.1893
0.350	*****	-0.3174	-0.1656	-0.3345	-0.2264
0.400	-0.3584	-0.3130	-0.1738	-0.3181	-0.3396
0.450	-0.3739	-0.3207	-0.1782	-0.3087	-0.4721
0.500	-0.3951	-0.3263	-0.1836	-0.3018	-0.5773
0.525	*****	-0.3291	-0.1889	-0.3072	-0.6181
0.550	-0.4206	-0.3306	-0.1980	-0.3277	-0.6490
0.575	*****	-0.3279	-0.2271	-0.3746	-0.7211
0.600	-0.4545	-0.3260	-0.3321	-0.4668	-0.8115
0.625	*****	*****	-0.5035	-0.6251	-0.9507
0.650	-0.4934	-0.5396	-0.7887	-0.8324	-1.0951
0.675	*****	-0.8560	-1.0418	-1.0450	-0.8616
0.700	-0.5151	-1.1157	-1.2115	-1.2134	-0.6823
0.725	*****	-1.2086	*****	-1.2139	-0.6379
0.750	-0.6800	-1.2829	*****	-0.9437	-0.5854
0.775	*****	-1.3222	-1.1732	-0.8877	-0.5520
0.800	-0.9447	-1.2993	-1.0646	-0.8788	*****
0.825	*****	-1.2421	-0.9772	-0.8940	-0.5210
0.850	-1.1308	-1.1834	-0.9425	-0.9005	-0.4955
0.875	*****	-1.1048	-0.9289	-0.8500	-0.4833
0.900	-1.1782	-1.0554	-0.8918	-0.7961	-0.4638
0.925	*****	-1.0226	-0.8432	-0.7865	-0.4398
0.950	-1.1625	-0.9926	-0.8179	-0.8007	-0.3853
0.975	*****	-0.9801	-0.7920	-0.7827	-0.3447
1.000	-1.1860	-1.0096	-0.7308	-0.7936	-0.3353
	$C_{p,l}$	$C_{p,l}$	$C_{p,l}$	$C_{p,l}$	$C_{p,l}$
-0.200	0.2802	0.2655	0.2832	*****	-0.5776
-0.400	0.2848	0.2713	0.2569	0.0855	-0.6683
-0.600	0.3016	0.2793	0.2496	0.1159	-0.6470
-0.700	0.3189	0.2860	0.2553	0.1295	-0.6252
-0.800	0.3330	0.3013	0.2636	0.1542	-0.5454
-0.850	0.3324	0.3106	0.2703	0.1664	-0.5375
-0.900	*****	0.3096	0.2783	0.1849	-0.4976
-0.950	0.2349	0.2558	0.2441	0.1858	-0.1725
-0.975	*****	0.1356	0.1501	0.1238	-0.0467
-1.000	-1.1803	-1.0374	-0.8446	-0.8197	-0.3674

Medium Radius L.E.
 Run No. = 7, Point No. = 141
 $C_N = 0.632$, $C_m = -0.1104$
 $\alpha = 13.4^\circ$, $M_\infty = 0.851$
 $R_{mac} = 6.0 \times 10^6$

Leading Edge Pressures

● starboard
 ○ port

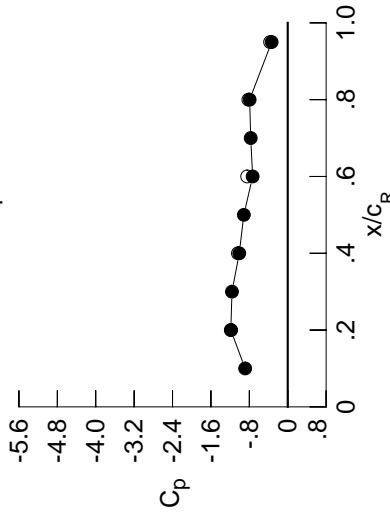

x/c_R	starb'd C_p	port C_p
0.10	-0.8872	*****
0.20	-1.1860	*****
0.30	-1.1614	*****
0.40	-1.0096	-1.0374
0.50	-0.9143	*****
0.60	-0.7308	-0.8446
0.70	-0.7714	*****
0.80	-0.7936	-0.8197
0.90	*****	*****
0.95	-0.3353	-0.3674

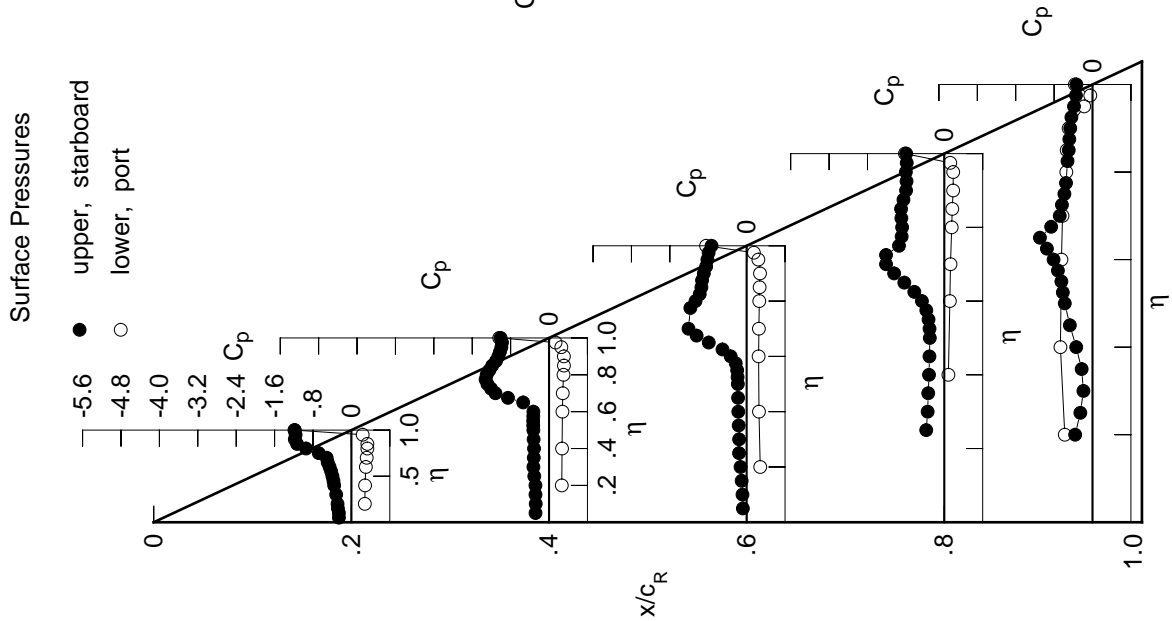

Table E1. Continued.

η	$x/c_R = 0.2$		$x/c_R = 0.4$		$x/c_R = 0.6$		$x/c_R = 0.8$		$x/c_R = 0.95$	
	$C_{p,u}$	$C_{p,u}$	$C_{p,u}$	$C_{p,u}$	$C_{p,u}$	$C_{p,u}$	$C_{p,u}$	$C_{p,u}$	$C_{p,u}$	$C_{p,u}$
0.050	-0.2809	-0.3131	-0.0972	*****	*****	*****	*****	*****	*****	*****
0.100	-0.2794	-0.3126	-0.1077	*****	*****	*****	*****	*****	*****	*****
0.150	-0.3031	-0.3122	-0.1214	*****	*****	*****	*****	*****	*****	*****
0.200	-0.3218	-0.3256	-0.1586	*****	*****	*****	*****	*****	*****	-0.3716
0.250	*****	-0.3486	-0.1630	-0.3949	-0.2730	*****	*****	*****	*****	*****
0.300	-0.3427	-0.3392	-0.1702	-0.3652	-0.2466	*****	*****	*****	*****	*****
0.350	-0.3447	-0.3369	-0.1813	-0.3520	-0.2860	*****	*****	*****	*****	*****
0.400	-0.3779	-0.3401	-0.1907	-0.3382	-0.4011	*****	*****	*****	*****	*****
0.450	-0.3866	-0.3456	-0.1918	-0.3302	-0.5307	*****	*****	*****	*****	*****
0.500	-0.4097	-0.3437	-0.2110	-0.3450	-0.6287	*****	*****	*****	*****	*****
0.525	*****	-0.3432	-0.2312	-0.3677	-0.6821	*****	*****	*****	*****	*****
0.550	-0.4339	-0.3451	-0.2824	-0.4242	-0.7358	*****	*****	*****	*****	*****
0.575	*****	-0.3614	-0.3719	-0.5199	-0.8399	*****	*****	*****	*****	*****
0.600	-0.4520	-0.4224	-0.5706	-0.6640	-0.9539	*****	*****	*****	*****	*****
0.625	*****	*****	-0.7903	-0.8434	-1.0964	*****	*****	*****	*****	*****
0.650	-0.4286	-0.9479	-1.0406	-1.0343	-0.8169	*****	*****	*****	*****	*****
0.675	*****	-1.2147	-1.2227	-1.1983	-0.6618	*****	*****	*****	*****	*****
0.700	-0.7065	-1.3475	-1.3429	-1.1724	-0.6266	*****	*****	*****	*****	*****
0.725	*****	-1.3254	*****	-0.9181	-0.5738	*****	*****	*****	*****	*****
0.750	-1.0497	-1.3204	*****	-0.8882	-0.5334	*****	*****	*****	*****	*****
0.775	*****	-1.3599	-1.0631	-0.8844	-0.5123	*****	*****	*****	*****	*****
0.800	-1.1827	-1.3241	-1.0078	-0.8967	*****	*****	*****	*****	*****	*****
0.825	*****	-1.2336	-0.9859	-0.9208	-0.4848	*****	*****	*****	*****	*****
0.850	-1.2370	-1.1583	-0.9918	-0.9179	-0.4594	*****	*****	*****	*****	*****
0.875	*****	-1.0964	-0.9760	-0.8606	-0.4417	*****	*****	*****	*****	*****
0.900	-1.2118	-1.0605	-0.9148	-0.8320	-0.4200	*****	*****	*****	*****	*****
0.925	*****	-1.0331	-0.8778	-0.8351	-0.3956	*****	*****	*****	*****	*****
0.950	-1.1747	-1.0012	-0.8668	-0.8442	-0.3565	*****	*****	*****	*****	*****
0.975	*****	-0.9916	-0.8423	-0.8287	-0.3240	*****	*****	*****	*****	*****
1.000	-1.2407	-1.0061	-0.7709	-0.8347	-0.3176	*****	*****	*****	*****	*****
-0.200	$C_{p,l}$	$C_{p,l}$	$C_{p,l}$	$C_{p,l}$	$C_{p,l}$	$C_{p,l}$	$C_{p,l}$	$C_{p,l}$	$C_{p,l}$	$C_{p,l}$
-0.400	0.3131	0.2881	0.3027	*****	-0.5895	*****	*****	*****	*****	*****
-0.600	0.3131	0.2978	0.2747	0.0988	-0.6593	*****	*****	*****	*****	*****
-0.700	0.3283	0.3035	0.2712	0.1309	-0.6385	*****	*****	*****	*****	*****
-0.800	0.3431	0.3104	0.2728	0.1446	-0.6137	*****	*****	*****	*****	*****
-0.850	0.3528	0.3224	0.2805	0.1707	-0.5336	*****	*****	*****	*****	*****
-0.900	0.3487	0.3275	0.2871	0.1803	-0.5247	*****	*****	*****	*****	*****
-0.950	*****	0.3197	0.2895	0.1952	-0.4811	*****	*****	*****	*****	*****
-0.975	0.2298	0.2534	0.2430	0.1878	-0.1656	*****	*****	*****	*****	*****
-1.000	*****	0.1177	0.1344	0.1101	-0.0465	*****	*****	*****	*****	*****
	-1.2161	-1.0321	-0.8622	-0.8521	-0.3454	*****	*****	*****	*****	*****

Medium Radius L.E.
 Run No. = 7, Point No. = 142
 $C_N = 0.683$, $C_m = -0.1175$
 $\alpha = 14.5^\circ$, $M_\infty = 0.850$
 $R_{mac} = 6.0 \times 10^6$

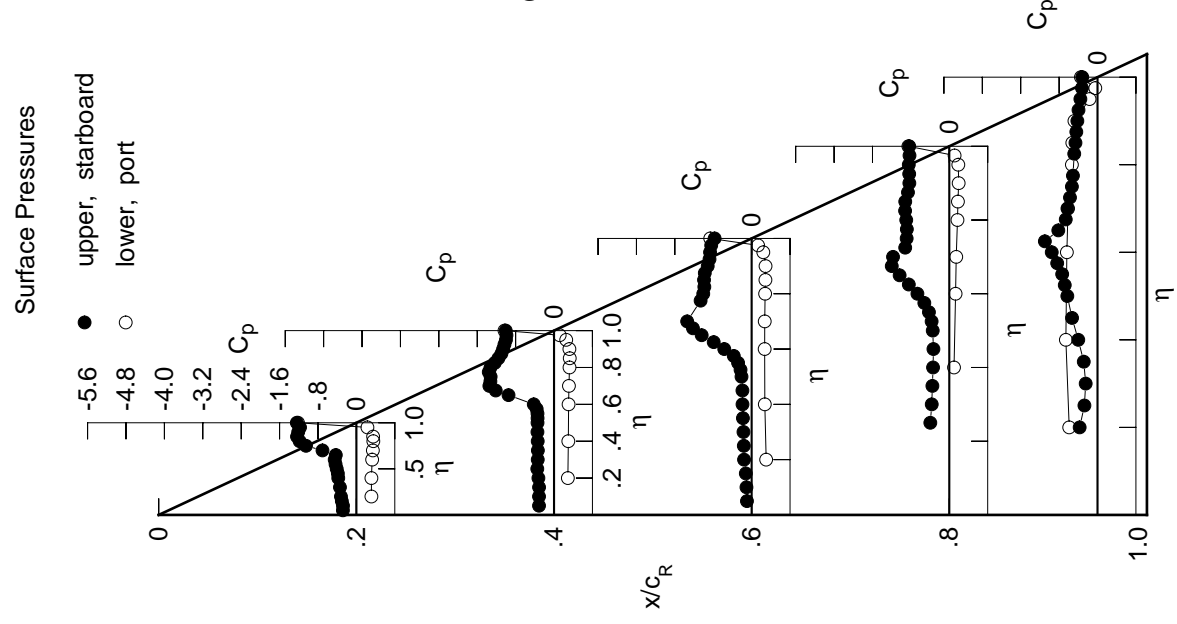
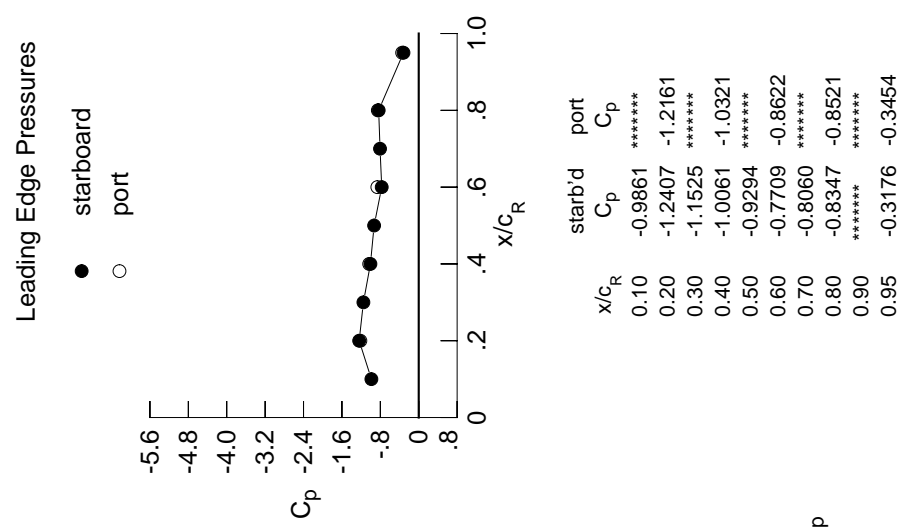
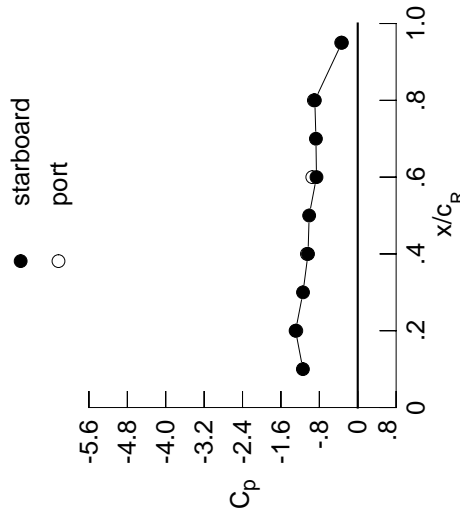

Table E1. Continued.

η	$x/c_R = .2$		$x/c_R = .4$		$x/c_R = .6$		$x/c_R = .8$		$x/c_R = .95$	
	$C_{p,u}$	$C_{p,u}$	$C_{p,u}$	$C_{p,u}$	$C_{p,u}$	$C_{p,u}$	$C_{p,u}$	$C_{p,u}$	$C_{p,u}$	$C_{p,u}$
0.050	-0.3312	-0.3953	-0.1331	*****	*****	*****	*****	*****	*****	*****
0.100	-0.3228	-0.3910	-0.1425	*****	*****	*****	*****	*****	*****	*****
0.150	-0.3541	-0.3970	-0.1663	*****	*****	*****	*****	*****	*****	*****
0.200	-0.3901	-0.4174	-0.1879	*****	*****	*****	*****	*****	*****	-0.4702
0.250	*****	-0.4058	-0.1955	-0.4611	-0.4418	*****	*****	*****	*****	*****
0.300	-0.3842	-0.4098	-0.2053	-0.4406	-0.4362	*****	*****	*****	*****	*****
0.350	*****	-0.4087	-0.2203	-0.4346	-0.5056	*****	*****	*****	*****	*****
0.400	-0.4026	-0.4118	-0.2348	-0.4328	-0.6368	*****	*****	*****	*****	*****
0.450	-0.4243	-0.4137	-0.2608	-0.4575	-0.7269	*****	*****	*****	*****	*****
0.500	-0.4374	-0.4280	-0.3589	-0.5415	-0.8125	*****	*****	*****	*****	*****
0.525	*****	-0.4646	-0.4578	-0.6183	-0.8827	*****	*****	*****	*****	*****
0.550	-0.4200	-0.5438	-0.6026	-0.7308	-0.9731	*****	*****	*****	*****	*****
0.575	*****	-0.6976	-0.7792	-0.8691	-1.0918	*****	*****	*****	*****	*****
0.600	-0.3541	-0.9180	-1.0005	-1.0166	-0.9841	*****	*****	*****	*****	*****
0.625	*****	*****	-1.1748	-1.1660	-0.6571	*****	*****	*****	*****	*****
0.650	-1.0747	-1.3764	-1.3308	-1.2995	-0.6417	*****	*****	*****	*****	*****
0.675	*****	-1.4992	-1.4185	-1.0613	-0.6273	*****	*****	*****	*****	*****
0.700	-1.3836	-1.5727	-1.1803	-0.9712	-0.5948	*****	*****	*****	*****	*****
0.725	*****	-1.5541	*****	-0.9604	-0.5592	*****	*****	*****	*****	*****
0.750	-1.3962	-1.4366	*****	-0.9537	-0.5299	*****	*****	*****	*****	*****
0.775	*****	-1.3903	-1.0994	-0.9580	-0.4987	*****	*****	*****	*****	*****
0.800	-1.3677	-1.3046	-1.1083	-0.9802	*****	*****	*****	*****	*****	*****
0.825	*****	-1.2102	-1.1365	-0.9902	-0.4490	*****	*****	*****	*****	*****
0.850	-1.3043	-1.1697	-1.1238	-0.9544	-0.4204	*****	*****	*****	*****	*****
0.875	*****	-1.1486	-1.0371	-0.9011	-0.4078	*****	*****	*****	*****	*****
0.900	-1.2275	-1.1168	-0.9764	-0.8890	-0.3935	*****	*****	*****	*****	*****
0.925	*****	-1.0655	-0.9721	-0.8987	-0.3792	*****	*****	*****	*****	*****
0.950	-1.2080	-1.0402	-0.9693	-0.9105	-0.3535	*****	*****	*****	*****	*****
0.975	*****	-1.0311	-0.9474	-0.8993	-0.3333	*****	*****	*****	*****	*****
1.000	-1.2947	-1.0356	-0.8595	-0.8939	-0.3307	*****	*****	*****	*****	*****
-0.200	$C_{p,l}$	0.3660	0.3367	0.3353	*****	*****	*****	*****	*****	-0.5813
-0.400	$C_{p,l}$	0.3728	0.3408	0.3123	0.1297	-0.6442	*****	*****	*****	*****
-0.600	$C_{p,l}$	0.3885	0.3489	0.3054	0.1592	-0.6206	*****	*****	*****	*****
-0.700	$C_{p,l}$	0.3993	0.3545	0.3105	0.1742	-0.5929	*****	*****	*****	*****
-0.800	$C_{p,l}$	0.3978	0.3636	0.3141	0.1950	-0.5123	*****	*****	*****	*****
-0.850	$C_{p,l}$	0.3833	0.3630	0.3167	0.2072	-0.4984	*****	*****	*****	*****
-0.900	$C_{p,l}$	*****	0.3421	0.3092	0.2165	-0.4514	*****	*****	*****	*****
-0.950	$C_{p,l}$	0.2230	0.2501	0.2362	0.1862	-0.1530	*****	*****	*****	*****
-0.975	$C_{p,l}$	*****	0.0857	0.0968	0.0833	-0.0553	*****	*****	*****	*****
-1.000	$C_{p,l}$	-1.2799	-1.0588	-0.9466	-0.9137	-0.3445	*****	*****	*****	*****

Medium Radius L.E.
 Run No. = 7, Point No. = 143
 $C_N = 0.788$, $C_m = -0.1311$
 $\alpha = 16.5^\circ$, $M_\infty = 0.849$
 $R_{mac} = 6.0 \times 10^6$

Leading Edge Pressures



x/c_R	starb'd C_p	port C_p
0.10	-1.1422	*****
0.20	-1.2947	-1.2799
0.30	-1.1398	*****
0.40	-1.0356	-1.0588
0.50	-1.0118	*****
0.60	-0.8595	-0.9466
0.70	-0.8708	*****
0.80	-0.8939	-0.9137
0.90	*****	*****
0.95	-0.3307	-0.3445

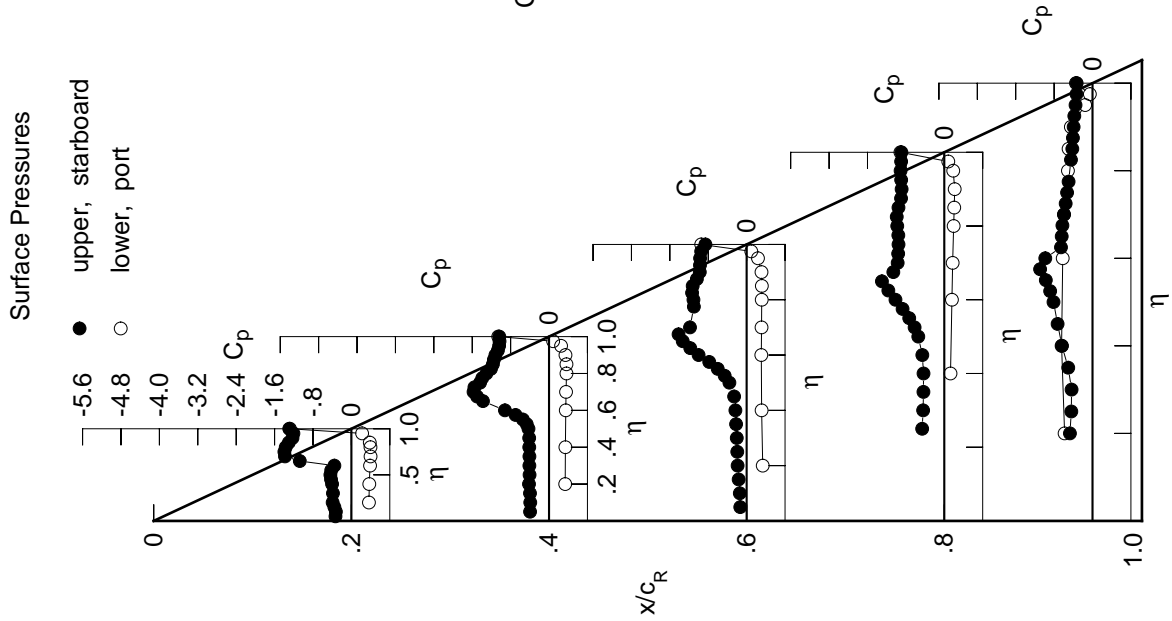

Table E1. Continued.

η	$x/c_R = .2$		$x/c_R = .4$		$x/c_R = .6$		$x/c_R = .8$		$x/c_R = .95$	
	$C_{p,u}$	$C_{p,u}$	$C_{p,u}$	$C_{p,u}$	$C_{p,u}$	$C_{p,u}$	$C_{p,u}$	$C_{p,u}$	$C_{p,u}$	$C_{p,u}$
0.050	-0.3857	-0.4578	-0.1777	*****	*****	*****	*****	*****	*****	*****
0.100	-0.3834	-0.4510	-0.1905	*****	*****	*****	*****	*****	*****	*****
0.150	-0.4224	-0.4736	-0.2218	*****	*****	*****	*****	*****	*****	*****
0.200	-0.4364	-0.4641	-0.2398	*****	*****	*****	*****	*****	*****	-0.4225
0.250	*****	-0.4670	-0.2589	-0.5108	-0.5038	*****	*****	*****	*****	*****
0.300	-0.4239	-0.4711	-0.2817	-0.4924	-0.5532	*****	*****	*****	*****	*****
0.350	*****	-0.4748	-0.3177	-0.4931	-0.6210	*****	*****	*****	*****	*****
0.400	-0.4530	-0.4844	-0.3749	-0.5111	-0.6914	*****	*****	*****	*****	*****
0.450	-0.4648	-0.5182	-0.4773	-0.5871	-0.7691	*****	*****	*****	*****	*****
0.500	-0.4513	-0.6276	-0.6882	-0.7507	-0.9077	*****	*****	*****	*****	*****
0.525	*****	-0.7479	-0.8315	-0.8751	-1.0002	*****	*****	*****	*****	*****
0.550	-0.4757	-0.9125	-0.9930	-1.0148	-1.1096	*****	*****	*****	*****	*****
0.575	*****	-1.1044	-1.1465	-1.1582	-1.2166	*****	*****	*****	*****	*****
0.600	-1.0691	-1.2865	-1.3013	-1.2842	-0.8243	*****	*****	*****	*****	*****
0.625	*****	*****	-1.4150	-1.3885	-0.7356	*****	*****	*****	*****	*****
0.650	-1.5675	-1.5656	-1.2920	-1.2447	-0.7209	*****	*****	*****	*****	*****
0.675	*****	-1.6069	-1.1545	-1.0988	-0.7202	*****	*****	*****	*****	*****
0.700	-1.5488	-1.4594	-1.1423	-1.0879	-0.7046	*****	*****	*****	*****	*****
0.725	*****	-1.4062	*****	-1.0988	-0.6739	*****	*****	*****	*****	*****
0.750	-1.5124	-1.3997	*****	-1.1144	-0.6184	*****	*****	*****	*****	*****
0.775	*****	-1.4065	-1.1605	-1.1279	-0.5509	*****	*****	*****	*****	*****
0.800	-1.4471	-1.4089	-1.1843	-1.1290	*****	*****	*****	*****	*****	*****
0.825	*****	-1.3730	-1.1632	-1.1082	-0.4788	*****	*****	*****	*****	*****
0.850	-1.3380	-1.3054	-1.1106	-1.0717	-0.4601	*****	*****	*****	*****	*****
0.875	*****	-1.2132	-1.0779	-0.9996	-0.4706	*****	*****	*****	*****	*****
0.900	-1.2591	-1.1430	-1.0707	-0.9433	-0.4744	*****	*****	*****	*****	*****
0.925	*****	-1.1151	-1.0685	-0.9231	-0.4861	*****	*****	*****	*****	*****
0.950	-1.2238	-1.1069	-1.0580	-0.9281	-0.4229	*****	*****	*****	*****	*****
0.975	*****	-1.1004	-1.0323	-0.9182	-0.3982	*****	*****	*****	*****	*****
1.000	-1.2779	-1.1031	-0.9253	-0.9039	-0.3884	*****	*****	*****	*****	*****
-0.200	$C_{p,l}$	$C_{p,l}$	$C_{p,l}$	$C_{p,l}$	$C_{p,l}$	$C_{p,l}$	$C_{p,l}$	$C_{p,l}$	$C_{p,l}$	$C_{p,l}$
-0.400	0.4237	0.3848	0.3741	*****	-0.5606	*****	*****	*****	*****	*****
-0.600	0.4292	0.3870	0.3495	0.1646	-0.6226	*****	*****	*****	*****	*****
-0.700	0.4432	0.3929	0.3431	0.1906	-0.5978	*****	*****	*****	*****	*****
-0.800	0.4483	0.3988	0.3463	0.2064	-0.5692	*****	*****	*****	*****	*****
-0.850	0.4366	0.4009	0.3467	0.2246	-0.4869	*****	*****	*****	*****	*****
-0.900	0.4133	0.3930	0.3437	0.2331	-0.4719	*****	*****	*****	*****	*****
-0.950	*****	0.3581	0.3239	0.2354	-0.4225	*****	*****	*****	*****	*****
-0.975	0.2139	0.2394	0.2242	0.1777	-0.1458	*****	*****	*****	*****	*****
-1.000	*****	0.0488	0.0574	0.0545	-0.0725	*****	*****	*****	*****	*****
	-1.3023	-1.1078	-1.0254	-0.9502	-0.3907	*****	*****	*****	*****	*****

Medium Radius L.E.
 Run No. = 7, Point No. = 144
 $C_N = 0.910$, $C_m = -0.1580$
 $\alpha = 18.5^\circ$, $M_\infty = 0.849$
 $R_{mac} = 6.0 \times 10^6$

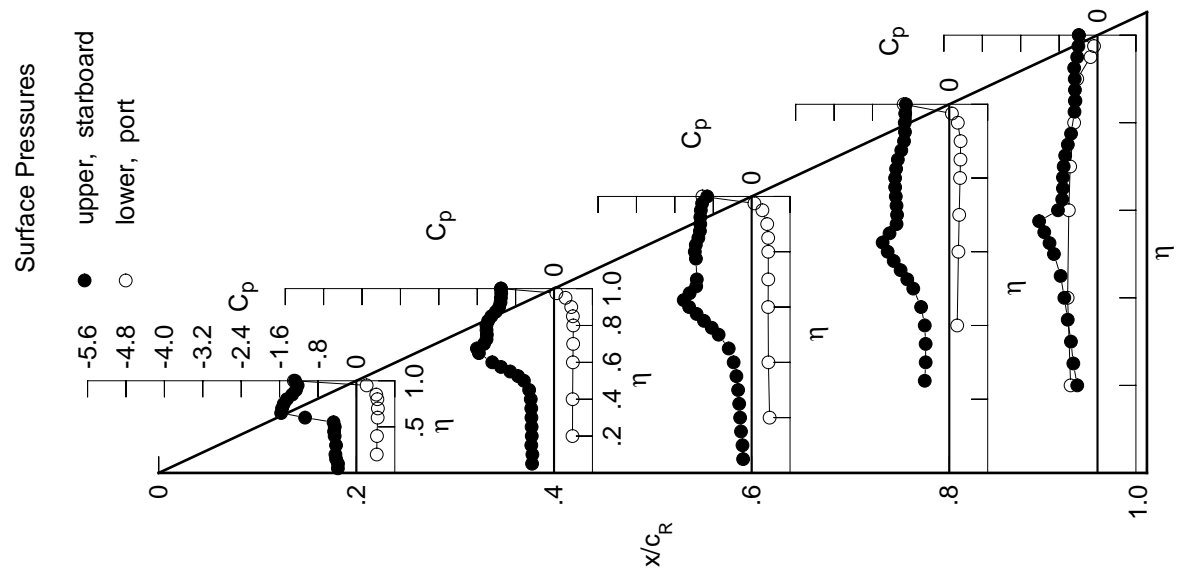
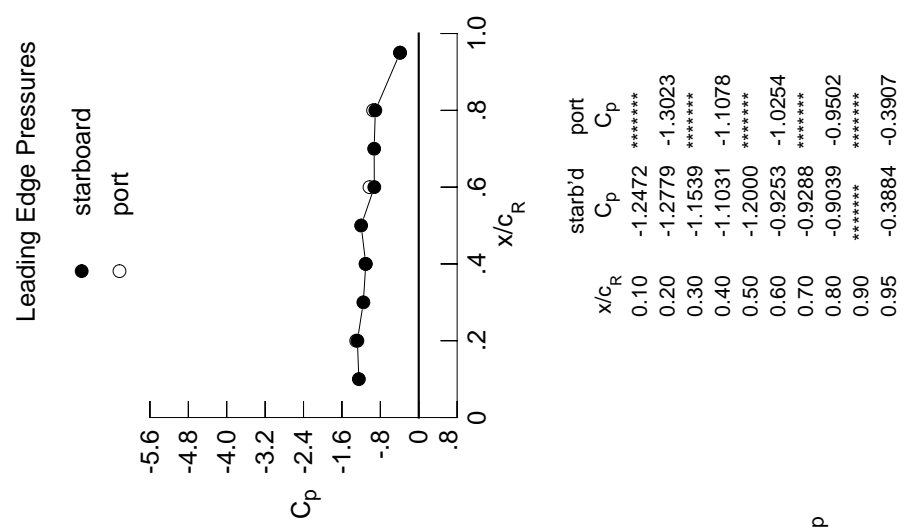
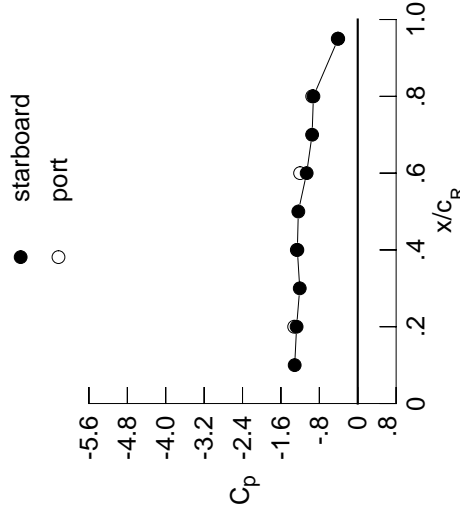

Table E1. Continued.

η	$x/c_R = 0.2$		$x/c_R = 0.4$		$x/c_R = 0.6$		$x/c_R = 0.8$		$x/c_R = 0.95$	
	$C_{p,u}$	$C_{p,u}$	$C_{p,u}$	$C_{p,u}$	$C_{p,u}$	$C_{p,u}$	$C_{p,u}$	$C_{p,u}$	$C_{p,u}$	$C_{p,u}$
0.050	-0.4543	-0.5233	-0.4056	*****	*****	*****	*****	*****	*****	*****
0.100	-0.4625	-0.5184	-0.4267	*****	*****	*****	*****	*****	*****	*****
0.150	-0.4939	-0.5432	-0.4463	*****	*****	*****	*****	*****	*****	*****
0.200	-0.4801	-0.5302	-0.4609	*****	*****	*****	*****	*****	*****	-0.3449
0.250	*****	-0.5421	-0.4839	-0.5851	-0.5800	-0.5425	*****	*****	*****	-0.4761
0.300	-0.4829	-0.5498	-0.5149	-0.5800	-0.5800	-0.5425	*****	*****	*****	-0.5425
0.350	*****	-0.5688	-0.5722	-0.5981	-0.5960	*****	*****	*****	*****	-0.5960
0.400	-0.5122	-0.6107	-0.6628	-0.6486	-0.6714	*****	*****	*****	*****	-0.6714
0.450	-0.5232	-0.7191	-0.8255	-0.7613	-0.7832	*****	*****	*****	*****	-0.7832
0.500	-0.6009	-0.9259	-1.0670	-0.9545	-0.9731	*****	*****	*****	*****	-0.9731
0.525	*****	-1.0788	-1.1976	-1.0671	-1.0795	*****	*****	*****	*****	-1.0795
0.550	-1.0081	-1.2283	-1.3187	-1.1907	-1.2004	*****	*****	*****	*****	-1.2004
0.575	*****	-1.3718	-1.4224	-1.3010	-1.0376	*****	*****	*****	*****	-1.0376
0.600	-1.5206	-1.4844	-1.5181	-1.4017	-0.7661	*****	*****	*****	*****	-0.7661
0.625	*****	*****	-1.5393	-1.4823	-0.7075	*****	*****	*****	*****	-0.7075
0.650	-1.6925	-1.4518	-1.3281	-1.1919	-0.6870	*****	*****	*****	*****	-0.6870
0.675	*****	-1.3662	-1.3074	-1.1407	-0.6598	*****	*****	*****	*****	-0.6598
0.700	-1.6728	-1.3540	-1.3033	-1.1294	-0.6160	*****	*****	*****	*****	-0.6160
0.725	*****	-1.3542	*****	-1.1266	-0.5696	*****	*****	*****	*****	-0.5696
0.750	-1.5807	-1.3676	*****	-1.1343	-0.5326	*****	*****	*****	*****	-0.5326
0.775	*****	-1.4056	-1.3072	-1.1551	-0.5217	*****	*****	*****	*****	-0.5217
0.800	-1.4697	-1.4377	-1.3297	-1.1734	*****	*****	*****	*****	*****	-1.1734
0.825	*****	-1.3803	-1.3184	-1.1610	-0.5441	*****	*****	*****	*****	-0.5441
0.850	-1.3504	-1.2890	-1.2692	-1.1335	-0.5256	*****	*****	*****	*****	-0.5256
0.875	*****	-1.2467	-1.2224	-1.0416	-0.5247	*****	*****	*****	*****	-0.5247
0.900	-1.2846	-1.2446	-1.2045	-0.9636	-0.5148	*****	*****	*****	*****	-0.5148
0.925	*****	-1.2552	-1.2066	-0.9334	-0.5212	*****	*****	*****	*****	-0.5212
0.950	-1.2428	-1.2469	-1.2046	-0.9488	-0.4529	*****	*****	*****	*****	-0.4529
0.975	*****	-1.2437	-1.1970	-0.9425	-0.4189	*****	*****	*****	*****	-0.4189
1.000	-1.2735	-1.2578	-1.0642	-0.9233	-0.4066	*****	*****	*****	*****	-0.4066
-0.200	$C_{p,l}$	$C_{p,l}$	$C_{p,l}$	$C_{p,l}$	$C_{p,l}$	$C_{p,l}$	$C_{p,l}$	$C_{p,l}$	$C_{p,l}$	$C_{p,l}$
-0.400	0.4796	0.4297	0.4103	*****	-0.5424	*****	*****	*****	*****	-0.5424
-0.600	0.4840	0.4320	0.3857	0.1937	-0.5996	*****	*****	*****	*****	-0.5996
-0.700	0.4935	0.4347	0.3779	0.2216	-0.5763	*****	*****	*****	*****	-0.5763
-0.800	0.4936	0.4390	0.3778	0.2320	-0.5447	*****	*****	*****	*****	-0.5447
-0.850	0.4703	0.4334	0.3760	0.2503	-0.4614	*****	*****	*****	*****	-0.4614
-0.900	0.4369	0.4171	0.3673	0.2555	-0.4461	*****	*****	*****	*****	-0.4461
-0.950	*****	0.3679	0.3360	0.2489	-0.3955	*****	*****	*****	*****	-0.3955
-0.975	0.1985	0.2241	0.2099	0.1748	-0.1387	*****	*****	*****	*****	-0.1387
-1.000	*****	0.0067	0.0204	0.0247	-0.0875	*****	*****	*****	*****	-0.0875
-1.000	-1.3241	-1.2691	-1.2011	-0.9487	-0.4164	*****	*****	*****	*****	-0.4164

Medium Radius L.E.
 Run No. = 7, Point No. = 145
 $C_N = 1.022$, $C_m = -0.1787$
 $\alpha = 20.6^\circ$, $M_\infty = 0.850$
 $R_{mac} = 6.0 \times 10^6$

Leading Edge Pressures



x/c_R	starb'd C_p	port C_p
0.10	-1.3133	*****
0.20	-1.2735	-1.3241
0.30	-1.2081	*****
0.40	-1.2578	-1.2691
0.50	-1.2378	*****
0.60	-1.0642	-1.2011
0.70	-0.9507	*****
0.80	-0.9233	-0.9487
0.90	*****	*****
0.95	-0.4066	-0.4164

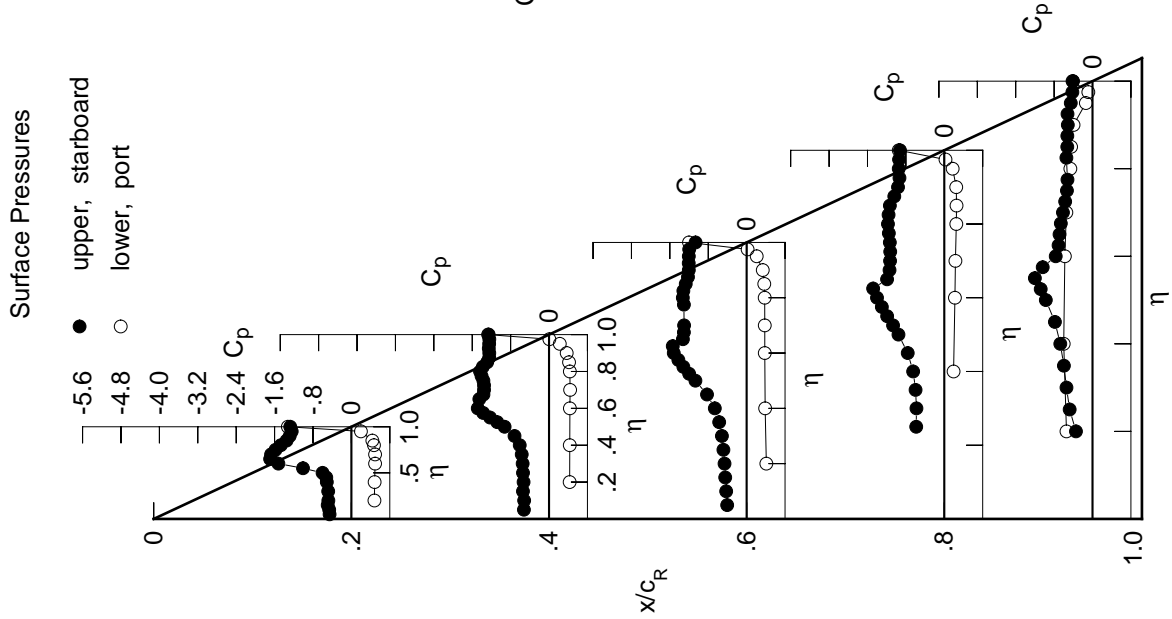
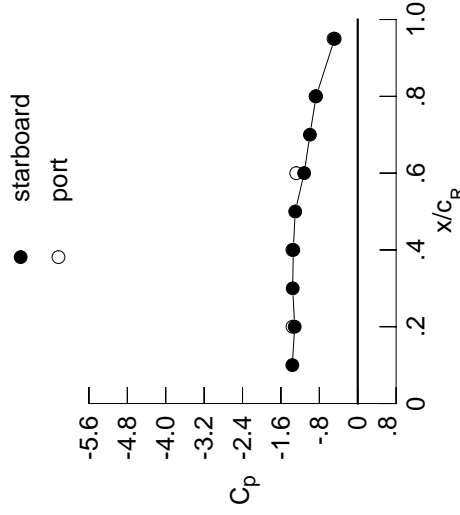

Table E1. Continued.

η	$x/c_R = .2$		$x/c_R = .4$		$x/c_R = .6$		$x/c_R = .8$		$x/c_R = .95$	
	$C_{p,u}$	$C_{p,u}$	$C_{p,u}$	$C_{p,u}$	$C_{p,u}$	$C_{p,u}$	$C_{p,u}$	$C_{p,u}$	$C_{p,u}$	$C_{p,u}$
0.050	-0.5179	-0.5993	-0.5803	*****	*****	*****	*****	*****	*****	*****
0.100	-0.5293	-0.5988	-0.5836	*****	*****	*****	*****	*****	*****	*****
0.150	-0.5573	-0.6037	-0.5864	*****	*****	*****	*****	*****	*****	*****
0.200	-0.5469	-0.6288	-0.5951	*****	*****	*****	*****	*****	*****	-0.2889
0.250	*****	-0.6348	-0.6122	-0.5378	-0.4337	*****	*****	*****	*****	-0.4337
0.300	-0.5552	-0.6617	-0.6431	-0.5654	-0.5178	*****	*****	*****	*****	-0.5178
0.350	*****	-0.7105	-0.7138	-0.6287	-0.5780	*****	*****	*****	*****	-0.5780
0.400	-0.6013	-0.8058	-0.8400	-0.7351	-0.6724	*****	*****	*****	*****	-0.6724
0.450	-0.6923	-0.9703	-1.0391	-0.8945	-0.8128	*****	*****	*****	*****	-0.8128
0.500	-0.9765	-1.1863	-1.2734	-1.1027	-1.0086	*****	*****	*****	*****	-1.0086
0.525	*****	-1.3080	-1.3858	-1.2037	-1.1063	*****	*****	*****	*****	-1.1063
0.550	-1.3939	-1.4153	-1.4814	-1.3113	-0.7400	*****	*****	*****	*****	-0.7400
0.575	*****	-1.5128	-1.5597	-1.4013	-0.6243	*****	*****	*****	*****	-0.6243
0.600	-1.6677	-1.5774	-1.6279	-1.4748	-0.6056	*****	*****	*****	*****	-0.6056
0.625	*****	*****	-1.4724	-1.2213	-0.5896	*****	*****	*****	*****	-0.5896
0.650	-1.6956	-1.3910	-1.4044	-1.1173	-0.5625	*****	*****	*****	*****	-0.5625
0.675	*****	-1.3846	-1.3961	-1.0956	-0.5398	*****	*****	*****	*****	-0.5398
0.700	-1.6940	-1.3866	-1.3986	-1.0992	-0.5409	*****	*****	*****	*****	-0.5409
0.725	*****	-1.3845	*****	-1.1144	-0.5449	*****	*****	*****	*****	-0.5449
0.750	-1.7032	-1.4057	*****	-1.1185	-0.5568	*****	*****	*****	*****	-0.5568
0.775	*****	-1.4237	-1.4328	-1.1168	-0.5750	*****	*****	*****	*****	-0.5750
0.800	-1.4779	-1.4091	-1.4527	-1.1325	*****	*****	*****	*****	*****	*****
0.825	*****	-1.3669	-1.4367	-1.1713	-0.6102	*****	*****	*****	*****	-0.6102
0.850	-1.3477	-1.3453	-1.3827	-1.1751	-0.5859	*****	*****	*****	*****	-0.5859
0.875	*****	-1.3437	-1.3059	-1.0632	-0.5825	*****	*****	*****	*****	-0.5825
0.900	-1.3099	-1.3431	-1.2689	-0.9436	-0.5733	*****	*****	*****	*****	-0.5733
0.925	*****	-1.3437	-1.2632	-0.8950	-0.5903	*****	*****	*****	*****	-0.5903
0.950	-1.2877	-1.3321	-1.2661	-0.9047	-0.5230	*****	*****	*****	*****	-0.5230
0.975	*****	-1.3259	-1.2556	-0.8940	-0.4961	*****	*****	*****	*****	-0.4961
1.000	-1.3136	-1.3424	-1.1160	-0.8677	-0.4805	*****	*****	*****	*****	-0.4805
-0.200	$C_{p,l}$	$C_{p,l}$	$C_{p,l}$	$C_{p,l}$	$C_{p,l}$	$C_{p,l}$	$C_{p,l}$	$C_{p,l}$	$C_{p,l}$	$C_{p,l}$
-0.400	0.5356	0.4753	0.4474	*****	-0.5171	*****	*****	*****	*****	-0.5171
-0.600	0.5407	0.4811	0.4248	0.2269	-0.5757	*****	*****	*****	*****	-0.5757
-0.700	0.5380	0.4817	0.4150	0.2530	-0.5476	*****	*****	*****	*****	-0.5476
-0.800	0.5029	0.4676	0.4059	0.2776	-0.4360	*****	*****	*****	*****	-0.4360
-0.850	0.4606	0.4440	0.3927	0.2808	-0.4216	*****	*****	*****	*****	-0.4216
-0.900	*****	0.3792	0.3488	0.2661	-0.3749	*****	*****	*****	*****	-0.3749
-0.950	0.1854	0.2127	0.1994	0.1717	-0.1397	*****	*****	*****	*****	-0.1397
-0.975	*****	-0.0298	-0.0119	0.0030	-0.1166	*****	*****	*****	*****	-0.1166
-1.000	-1.3591	-1.3607	-1.2816	-0.8795	-0.5042	*****	*****	*****	*****	-0.5042

Medium Radius L.E.
 Run No. = 7, Point No. = 146
 $C_N = 1.075$, $C_m = -0.1836$
 $\alpha = 22.6^\circ$, $M_\infty = 0.850$
 $R_{mac} = 6.0 \times 10^6$

Leading Edge Pressures



x/c_R	starb'd C_p	port C_p
0.10	-1.3623	*****
0.20	-1.3136	-1.3591
0.30	-1.3549	*****
0.40	-1.3424	-1.3607
0.50	-1.3021	*****
0.60	-1.1160	-1.2816
0.70	-0.9958	*****
0.80	-0.8677	-0.8795
0.90	*****	*****
0.95	-0.4805	-0.5042

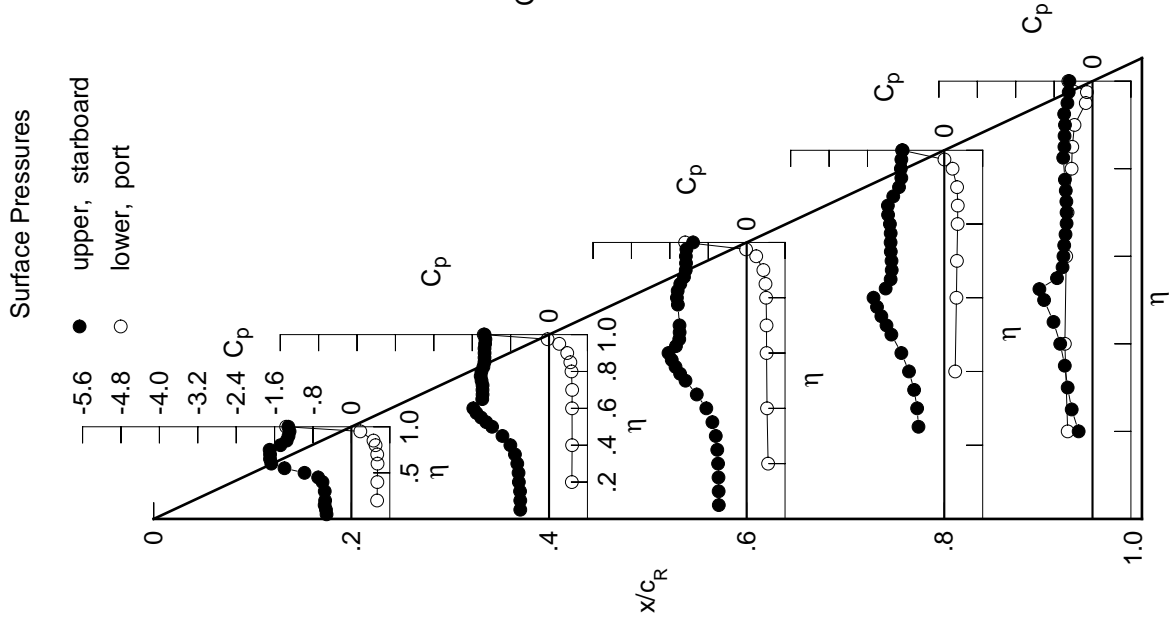
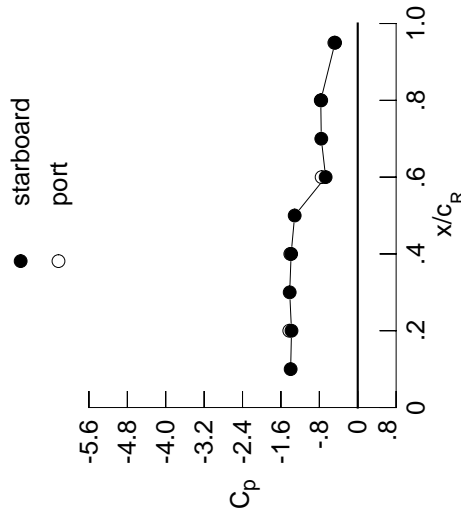

Table E1. Continued.

η	$x/c_R = .2$		$x/c_R = .4$		$x/c_R = .6$		$x/c_R = .8$		$x/c_R = .95$	
	$C_{p,u}$	$C_{p,u}$	$C_{p,u}$	$C_{p,u}$	$C_{p,u}$	$C_{p,u}$	$C_{p,u}$	$C_{p,u}$	$C_{p,u}$	$C_{p,u}$
0.050	-0.5983	-0.6563	-0.0342	*****	*****	*****	*****	*****	*****	*****
0.100	-0.5963	-0.6563	-0.0411	*****	*****	*****	*****	*****	*****	*****
0.150	-0.6190	-0.6642	-0.0577	*****	*****	*****	*****	*****	*****	*****
0.200	-0.6401	-0.6702	-0.0814	*****	*****	*****	*****	*****	*****	-0.5933
0.250	*****	-0.7028	-0.1169	-0.8827	-0.8827	-0.8827	-0.8827	-0.8827	-0.8827	-0.6815
0.300	-0.6657	-0.7493	-0.1809	-0.9157	-0.9157	-0.9157	-0.9157	-0.9157	-0.9157	-0.7578
0.350	*****	-0.8335	-0.2979	-0.9640	-0.9640	-0.9640	-0.9640	-0.9640	-0.9640	-0.8155
0.400	-0.7947	-0.9688	-0.4861	-0.9936	-0.9936	-0.9936	-0.9936	-0.9936	-0.9936	-0.8516
0.450	-0.9994	-1.1575	-0.7306	-1.0073	-1.0073	-1.0073	-1.0073	-1.0073	-1.0073	-0.8050
0.500	-1.3136	-1.3564	-1.0219	-0.9800	-0.9800	-0.9800	-0.9800	-0.9800	-0.9800	-0.7370
0.525	*****	-1.4506	-1.1549	-0.9658	-0.9658	-0.9658	-0.9658	-0.9658	-0.9658	-0.7411
0.550	-1.5781	-1.5343	-1.2656	-0.9458	-0.9458	-0.9458	-0.9458	-0.9458	-0.9458	-0.7346
0.575	*****	-1.6051	-1.3538	-0.9533	-0.9533	-0.9533	-0.9533	-0.9533	-0.9533	-0.7476
0.600	-1.7263	-1.6153	-1.3921	-0.9587	-0.9587	-0.9587	-0.9587	-0.9587	-0.9587	-0.7533
0.625	*****	*****	-1.2653	-0.9574	-0.9574	-0.9574	-0.9574	-0.9574	-0.9574	-0.7576
0.650	-1.6734	-1.4503	-1.1175	-0.9526	-0.9526	-0.9526	-0.9526	-0.9526	-0.9526	-0.7556
0.675	*****	-1.4463	-1.0493	-0.9442	-0.9442	-0.9442	-0.9442	-0.9442	-0.9442	-0.7409
0.700	-1.6663	-1.4453	-1.0090	-0.9361	-0.9361	-0.9361	-0.9361	-0.9361	-0.9361	-0.7346
0.725	*****	-1.4448	*****	-0.9233	-0.9233	-0.9233	-0.9233	-0.9233	-0.9233	-0.7247
0.750	-1.6507	-1.4536	*****	-0.8979	-0.8979	-0.8979	-0.8979	-0.8979	-0.8979	-0.7054
0.775	*****	-1.4790	-0.9174	-0.8847	-0.8847	-0.8847	-0.8847	-0.8847	-0.8847	-0.6861
0.800	-1.4691	-1.4791	-0.9026	-0.8751	-0.8751	-0.8751	-0.8751	-0.8751	-0.8751	*****
0.825	*****	-1.4293	-0.8976	-0.8715	-0.8715	-0.8715	-0.8715	-0.8715	-0.8715	-0.6548
0.850	-1.3812	-1.3918	-0.8843	-0.8629	-0.8629	-0.8629	-0.8629	-0.8629	-0.8629	-0.6344
0.875	*****	-1.3758	-0.8495	-0.8543	-0.8543	-0.8543	-0.8543	-0.8543	-0.8543	-0.6120
0.900	-1.3600	-1.3792	-0.8083	-0.8447	-0.8447	-0.8447	-0.8447	-0.8447	-0.8447	-0.5870
0.925	*****	-1.3814	-0.7809	-0.8236	-0.8236	-0.8236	-0.8236	-0.8236	-0.8236	-0.5736
0.950	-1.3442	-1.3756	-0.7688	-0.8110	-0.8110	-0.8110	-0.8110	-0.8110	-0.8110	-0.5346
0.975	*****	-1.3687	-0.7571	-0.7877	-0.7877	-0.7877	-0.7877	-0.7877	-0.7877	-0.4945
1.000	-1.3797	-1.3873	-0.6684	-0.7703	-0.7703	-0.7703	-0.7703	-0.7703	-0.7703	-0.4721
-0.200	$C_{p,l}$	$C_{p,l}$	$C_{p,l}$	$C_{p,l}$	$C_{p,l}$	$C_{p,l}$	$C_{p,l}$	$C_{p,l}$	$C_{p,l}$	$C_{p,l}$
-0.400	0.5866	0.5240	0.4844	*****	*****	*****	*****	*****	*****	-0.5205
-0.600	0.5928	0.5253	0.4615	0.2537	0.2537	0.2537	0.2537	0.2537	0.2537	-0.5716
-0.700	0.5928	0.5237	0.4528	0.2752	0.2752	0.2752	0.2752	0.2752	0.2752	-0.5474
-0.800	0.5790	0.5209	0.4505	0.2838	0.2838	0.2838	0.2838	0.2838	0.2838	-0.5157
-0.850	0.5314	0.4996	0.4403	0.2944	0.2944	0.2944	0.2944	0.2944	0.2944	-0.4349
-0.900	0.4796	0.4671	0.4232	0.2954	0.2954	0.2954	0.2954	0.2954	0.2954	-0.4235
-0.950	*****	0.3902	0.3738	0.2761	0.2761	0.2761	0.2761	0.2761	0.2761	-0.3761
-0.975	0.1693	0.2011	0.2168	0.1751	0.1751	0.1751	0.1751	0.1751	0.1751	-0.1507
-1.000	*****	-0.0593	0.0022	0.0041	0.0041	0.0041	0.0041	0.0041	0.0041	-0.1379
-1.000	-1.4257	-1.4047	-0.7518	-0.7607	-0.7607	-0.7607	-0.7607	-0.7607	-0.7607	-0.4868

Medium Radius L.E.
 Run No. = 7, Point No. = 147
 $C_N = 1.122$, $C_m = -0.1916$
 $\alpha = 24.6^\circ$, $M_\infty = 0.850$
 $R_{mac} = 6.0 \times 10^6$

Leading Edge Pressures



x/c_R	starb'd C_p	port C_p
0.10	-1.3976	*****
0.20	-1.3797	-1.4257
0.30	-1.4173	*****
0.40	-1.3873	-1.4047
0.50	-1.3138	*****
0.60	-0.6684	-0.7518
0.70	-0.7592	*****
0.80	-0.7703	-0.7607
0.90	*****	*****
0.95	-0.4721	-0.4868

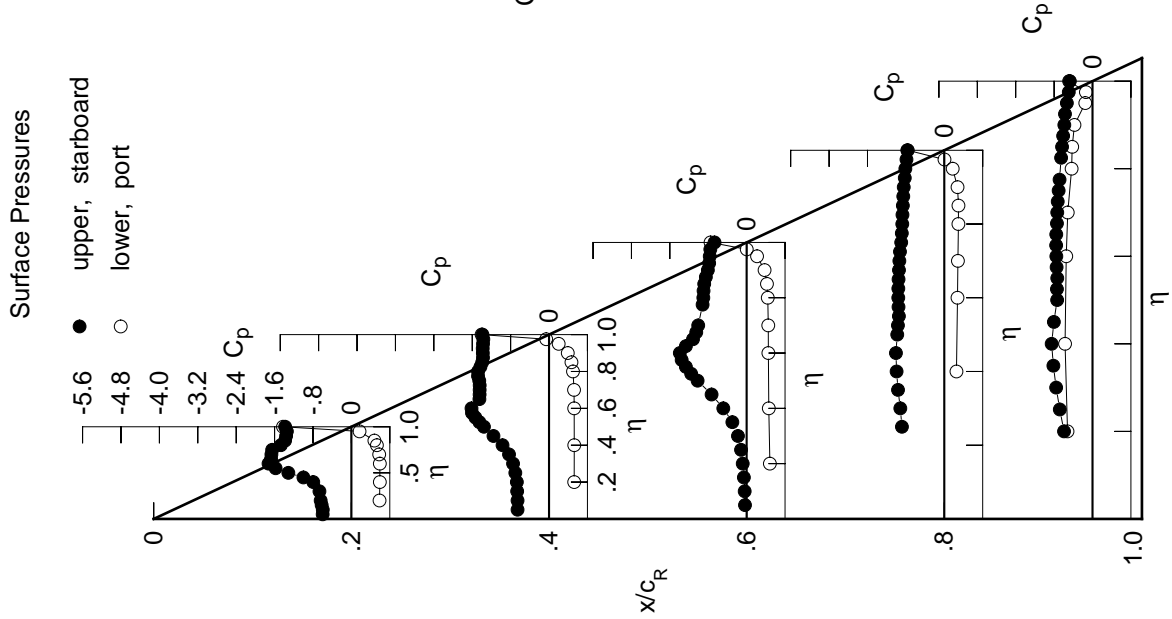

Table E1. Concluded.

η	$x/c_R = .2$		$x/c_R = .4$		$x/c_R = .6$		$x/c_R = .8$		$x/c_R = .95$	
	$C_{p,u}$	$C_{p,u}$	$C_{p,u}$	$C_{p,u}$	$C_{p,u}$	$C_{p,u}$	$C_{p,u}$	$C_{p,u}$	$C_{p,u}$	$C_{p,u}$
0.050	-0.6843	-0.7147	-0.1515	*****	*****	*****	*****	*****	*****	*****
0.100	-0.6863	-0.7261	-0.1557	*****	*****	*****	*****	*****	*****	*****
0.150	-0.7056	-0.7391	-0.1593	*****	*****	*****	*****	*****	*****	*****
0.200	-0.7116	-0.7545	-0.1767	*****	*****	*****	*****	*****	*****	-0.7182
0.250	*****	-0.7958	-0.2118	-1.0110	-0.8238	*****	*****	*****	*****	-0.8238
0.300	-0.7755	-0.8651	-0.2868	-0.9882	-0.8946	*****	*****	*****	*****	-0.8946
0.350	*****	-0.9735	-0.4080	-0.9680	-0.8811	*****	*****	*****	*****	-0.8811
0.400	-1.0335	-1.1265	-0.6026	-0.9149	-0.8064	*****	*****	*****	*****	-0.8064
0.450	-1.2803	-1.3079	-0.8202	-0.8893	-0.7355	*****	*****	*****	*****	-0.7355
0.500	-1.5264	-1.4739	-1.0684	-0.8907	-0.7224	*****	*****	*****	*****	-0.7224
0.525	*****	-1.5491	-1.1725	-0.9142	-0.7414	*****	*****	*****	*****	-0.7414
0.550	-1.6952	-1.6154	-1.2483	-0.9232	-0.7476	*****	*****	*****	*****	-0.7476
0.575	*****	-1.6676	-1.2882	-0.9523	-0.7645	*****	*****	*****	*****	-0.7645
0.600	-1.6767	-1.6341	-1.2149	-0.9658	-0.7704	*****	*****	*****	*****	-0.7704
0.625	*****	*****	-1.0468	-0.9576	-0.7734	*****	*****	*****	*****	-0.7734
0.650	-1.6380	-1.5087	-0.9621	-0.9568	-0.7697	*****	*****	*****	*****	-0.7697
0.675	*****	-1.5080	-0.9500	-0.9536	-0.7579	*****	*****	*****	*****	-0.7579
0.700	-1.6494	-1.5057	-0.9458	-0.9523	-0.7554	*****	*****	*****	*****	-0.7554
0.725	*****	-1.5035	*****	-0.9454	-0.7472	*****	*****	*****	*****	-0.7472
0.750	-1.6799	-1.5087	*****	-0.9299	-0.7300	*****	*****	*****	*****	-0.7300
0.775	*****	-1.5326	-0.8977	-0.9209	-0.7123	*****	*****	*****	*****	-0.7123
0.800	-1.5215	-1.5347	-0.8836	-0.9037	*****	*****	*****	*****	*****	*****
0.825	*****	-1.4924	-0.8783	-0.9067	-0.6758	*****	*****	*****	*****	-0.6758
0.850	-1.4235	-1.4552	-0.8640	-0.8944	-0.6610	*****	*****	*****	*****	-0.6610
0.875	*****	-1.4376	-0.8567	-0.8830	-0.6428	*****	*****	*****	*****	-0.6428
0.900	-1.4159	-1.4379	-0.8396	-0.8685	-0.6254	*****	*****	*****	*****	-0.6254
0.925	*****	-1.4411	-0.8303	-0.8494	-0.6112	*****	*****	*****	*****	-0.6112
0.950	-1.4078	-1.4371	-0.8243	-0.8362	-0.5788	*****	*****	*****	*****	-0.5788
0.975	*****	-1.4308	-0.8187	-0.8082	-0.5380	*****	*****	*****	*****	-0.5380
1.000	-1.4611	-1.4523	-0.7243	-0.7848	-0.5120	*****	*****	*****	*****	-0.5120
-0.200	$C_{p,l}$	$C_{p,l}$	$C_{p,l}$	$C_{p,l}$	$C_{p,l}$	$C_{p,l}$	$C_{p,l}$	$C_{p,l}$	$C_{p,l}$	$C_{p,l}$
-0.400	0.6418	0.5703	0.5234	*****	-0.4928	*****	*****	*****	*****	-0.4928
-0.600	0.6457	0.5713	0.5008	0.2873	-0.5478	*****	*****	*****	*****	-0.5478
-0.700	0.6394	0.5697	0.4865	0.3080	-0.5201	*****	*****	*****	*****	-0.5201
-0.800	0.6180	0.5605	0.4839	0.3139	-0.4904	*****	*****	*****	*****	-0.4904
-0.850	0.5573	0.5308	0.4682	0.3236	-0.4115	*****	*****	*****	*****	-0.4115
-0.850	0.4976	0.4915	0.4462	0.3189	-0.3996	*****	*****	*****	*****	-0.3996
-0.900	*****	0.4012	0.3852	0.2918	-0.3514	*****	*****	*****	*****	-0.3514
-0.950	0.1516	0.1901	0.2050	0.1721	-0.1457	*****	*****	*****	*****	-0.1457
-0.975	*****	-0.0889	-0.0302	-0.0170	-0.1516	*****	*****	*****	*****	-0.1516
-1.000	-1.4961	-1.4600	-0.8503	-0.7334	-0.5185	*****	*****	*****	*****	-0.5185

Medium Radius L.E.
 Run No. = 7, Point No. = 148
 $C_N = 1.196$, $C_m = -0.2047$
 $\alpha = 26.6^\circ$, $M_\infty = 0.849$
 $R_{mac} = 6.0 \times 10^6$

Leading Edge Pressures

● starboard
 ○ port

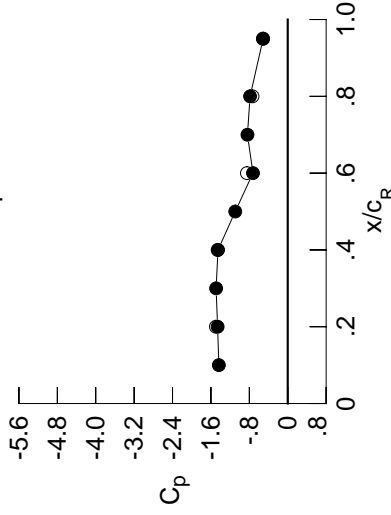

x/c_R	starb'd C_p	port C_p
0.10	-1.4349	*****
0.20	-1.4611	-1.4961
0.30	-1.4923	*****
0.40	-1.4523	-1.4600
0.50	-1.0937	*****
0.60	-0.7243	-0.8503
0.70	-0.8393	*****
0.80	-0.7848	-0.7334
0.90	*****	*****
0.95	-0.5120	-0.5185

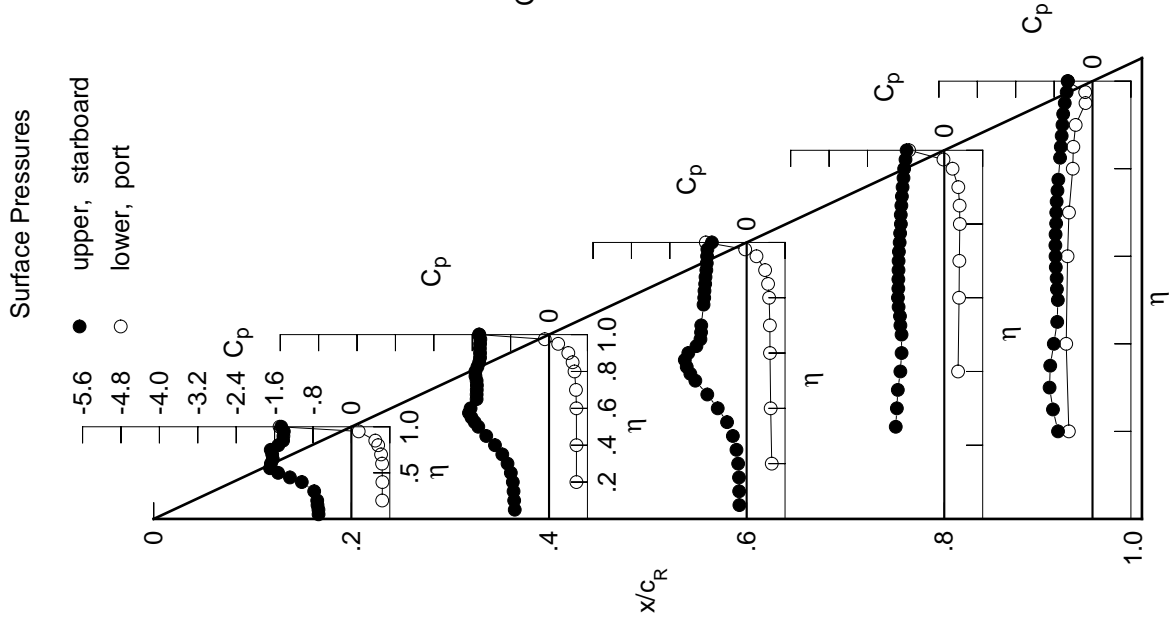
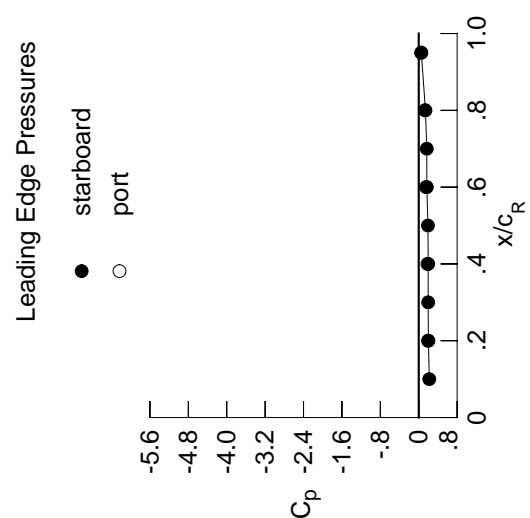
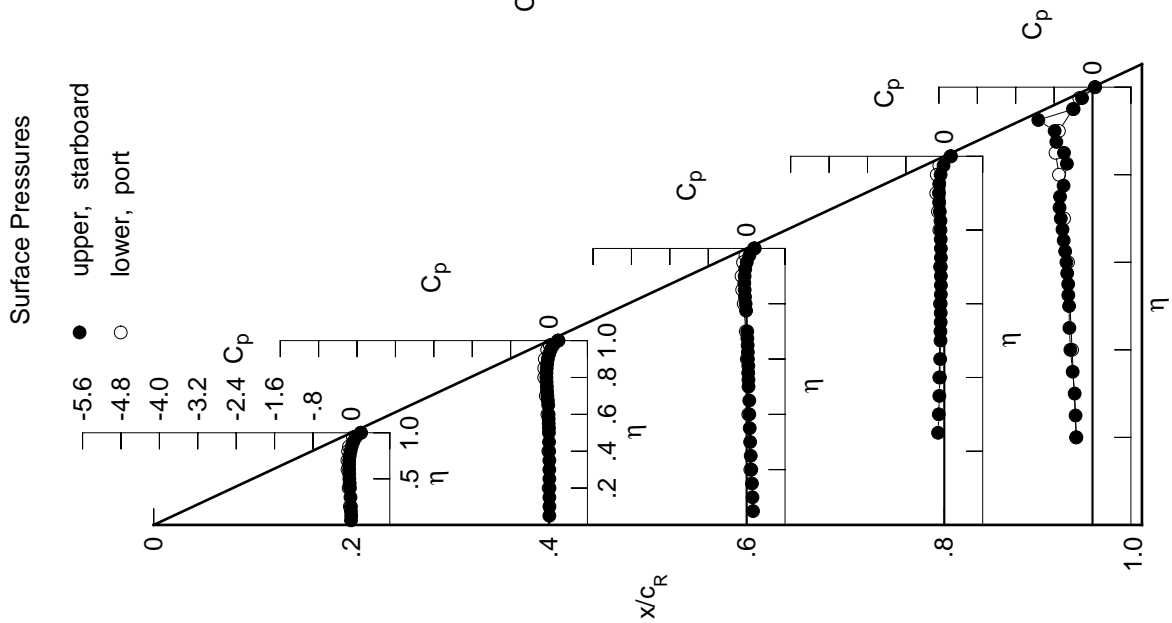

Table E2. Tabulations and Plots of Surface Pressure Coefficients.

η	$x/c_R = .2$		$x/c_R = .4$		$x/c_R = .6$		$x/c_R = .8$		$x/c_R = .95$	
	$C_{p,u}$	$C_{p,u}$	$C_{p,u}$	$C_{p,u}$	$C_{p,u}$	$C_{p,u}$	$C_{p,u}$	$C_{p,u}$	$C_{p,u}$	$C_{p,u}$
0.050	-0.0080	0.0075	0.1327	*****	*****	*****	*****	*****	*****	*****
0.100	-0.0036	0.0081	0.1213	*****	*****	*****	*****	*****	*****	*****
0.150	-0.0100	0.0070	0.1105	*****	*****	*****	*****	*****	*****	*****
0.200	-0.0106	0.0095	0.0968	*****	*****	*****	*****	*****	*****	*****
0.250	*****	0.0071	0.0847	-0.1299	-0.3531	*****	*****	*****	*****	*****
0.300	-0.0190	0.0060	0.0727	-0.1145	-0.3718	*****	*****	*****	*****	*****
0.350	*****	0.0070	0.0638	-0.1035	-0.4137	*****	*****	*****	*****	*****
0.400	-0.0313	0.0021	0.0561	-0.0915	-0.4608	*****	*****	*****	*****	*****
0.450	-0.0362	0.0003	0.0552	-0.0853	-0.4817	*****	*****	*****	*****	*****
0.500	-0.0423	-0.0031	0.0393	-0.0788	-0.4883	*****	*****	*****	*****	*****
0.525	*****	-0.0022	0.0375	-0.0797	-0.5040	*****	*****	*****	*****	*****
0.550	-0.0450	-0.0073	0.0331	-0.0754	-0.5061	*****	*****	*****	*****	*****
0.575	*****	-0.0082	0.0352	-0.0743	-0.5268	*****	*****	*****	*****	*****
0.600	-0.0483	-0.0099	0.0265	-0.0742	-0.5441	*****	*****	*****	*****	*****
0.625	*****	*****	0.0249	-0.0713	-0.5694	*****	*****	*****	*****	*****
0.650	-0.0481	-0.0166	0.0209	-0.0704	-0.5998	*****	*****	*****	*****	*****
0.675	*****	-0.0250	0.0154	-0.0721	-0.6257	*****	*****	*****	*****	*****
0.700	-0.0460	-0.0343	0.0126	-0.0719	-0.6607	*****	*****	*****	*****	*****
0.725	*****	-0.0420	*****	-0.0707	-0.6876	*****	*****	*****	*****	*****
0.750	-0.0352	-0.0459	*****	-0.0711	-0.6771	*****	*****	*****	*****	*****
0.775	*****	-0.0511	-0.0119	-0.0744	-0.6029	*****	*****	*****	*****	*****
0.800	-0.0173	-0.0549	-0.0219	-0.0792	*****	*****	*****	*****	*****	*****
0.825	*****	-0.0539	-0.0345	-0.0793	-0.5335	*****	*****	*****	*****	*****
0.850	0.0049	-0.0478	-0.0416	-0.0939	-0.5941	*****	*****	*****	*****	*****
0.875	*****	-0.0384	-0.0485	-0.1069	-0.7533	*****	*****	*****	*****	*****
0.900	0.0384	-0.0255	-0.0425	-0.1118	-0.7891	*****	*****	*****	*****	*****
0.925	*****	-0.0015	-0.0292	-0.1055	-1.1290	*****	*****	*****	*****	*****
0.950	0.0892	0.0333	0.0013	-0.0767	-0.3932	*****	*****	*****	*****	*****
0.975	*****	0.0861	0.0577	-0.0151	-0.2181	*****	*****	*****	*****	*****
1.000	0.2012	0.1977	0.1689	0.1404	0.0536	*****	*****	*****	*****	*****
	$C_{p,l}$	$C_{p,l}$	$C_{p,l}$	$C_{p,l}$	$C_{p,l}$	$C_{p,l}$	$C_{p,l}$	$C_{p,l}$	$C_{p,l}$	$C_{p,l}$
-0.200	-0.0329	-0.0083	0.0767	*****	-0.3370	*****	*****	*****	*****	*****
-0.400	-0.0572	-0.0143	0.0342	-0.1039	-0.4257	*****	*****	*****	*****	*****
-0.600	-0.0807	-0.0336	0.0043	-0.0892	-0.5095	*****	*****	*****	*****	*****
-0.700	-0.0825	-0.0672	-0.0179	-0.0892	-0.5929	*****	*****	*****	*****	*****
-0.800	-0.0680	-0.1011	-0.0612	-0.1032	-0.6994	*****	*****	*****	*****	*****
-0.850	-0.0502	-0.0996	-0.0926	-0.1329	-0.7707	*****	*****	*****	*****	*****
-0.900	*****	-0.0865	-0.1053	-0.1682	-0.7003	*****	*****	*****	*****	*****
-0.950	0.0316	-0.0382	-0.0755	-0.1570	-0.4077	*****	*****	*****	*****	*****
-0.975	*****	0.0151	-0.0249	-0.1032	-0.2752	*****	*****	*****	*****	*****
-1.000	0.1933	0.1815	0.1520	0.1282	0.0510	*****	*****	*****	*****	*****

Medium Radius L.E.
 Run No. = 10, Point No. = 193
 $C_N = -0.021$, $C_m = 0.0001$
 $\alpha = -0.5^\circ$, $M_\infty = 0.849$
 $R_{mac} = 11.8 \times 10^6$



x/c_R	starb'd C_p	port C_p
0.10	0.2202	*****
0.20	0.2012	0.1933
0.30	0.1964	*****
0.40	0.1977	0.1815
0.50	0.1921	*****
0.60	0.1689	0.1520
0.70	0.1675	*****
0.80	0.1404	0.1282
0.90	*****	*****
0.95	0.0536	0.0510

Table E2. Continued.

η	x/c_R .2	x/c_R .4	x/c_R .6	x/c_R .8	x/c_R .95
	$C_{p,u}$	$C_{p,u}$	$C_{p,u}$	$C_{p,u}$	$C_{p,u}$
0.050	-0.0161	0.0010	0.1252	0.1252	0.1252
0.100	-0.0126	-0.0023	0.1158	0.1158	0.1158
0.150	-0.0192	-0.0014	0.1050	0.1050	0.1050
0.200	-0.0209	0.0002	0.0923	0.0923	0.0923
0.250	0.0000	0.0000	0.0789	0.0789	0.0789
0.300	-0.0296	-0.0028	0.0671	0.1214	-0.3639
0.350	0.0000	-0.0035	0.0569	-0.1078	-0.4009
0.400	-0.0423	-0.0061	0.0496	-0.0988	-0.4469
0.450	-0.0484	-0.0097	0.0484	-0.0904	-0.4674
0.500	-0.0547	-0.0104	0.0320	-0.0870	-0.4728
0.525	0.0000	-0.0135	0.0292	-0.0855	-0.4856
0.550	-0.0576	-0.0169	0.0256	-0.0830	-0.4858
0.575	0.0000	-0.0198	0.0264	-0.0832	-0.5050
0.600	-0.0627	-0.0205	0.0180	-0.0815	-0.5226
0.625	0.0000	0.0000	0.0169	-0.0796	-0.5447
0.650	-0.0631	-0.0287	0.0119	-0.0793	-0.5769
0.675	0.0000	-0.0384	0.0048	-0.0793	-0.6031
0.700	-0.0610	-0.0467	0.0035	-0.0811	-0.6383
0.725	0.0000	-0.0565	0.0000	-0.0799	-0.6525
0.750	-0.0521	-0.0614	0.0000	-0.0815	-0.6195
0.775	0.0000	-0.0673	-0.0246	-0.0857	-0.5102
0.800	-0.0365	-0.0721	-0.0380	-0.0903	0.0000
0.825	0.0000	-0.0748	-0.0516	-0.0932	-0.4667
0.850	-0.0141	-0.0691	-0.0615	-0.1103	-0.5528
0.875	0.0000	-0.0626	-0.0691	-0.1245	-0.7579
0.900	0.0179	-0.0496	-0.0674	-0.1347	-0.8061
0.925	0.0000	-0.0286	-0.0556	-0.1307	-1.1204
0.950	0.0678	0.0060	-0.0280	-0.1068	-0.4106
0.975	0.0000	0.0585	0.0264	-0.0476	-0.2430
1.000	0.2038	0.2019	0.1848	0.1498	0.0611
	$C_{p,l}$	$C_{p,l}$	$C_{p,l}$	$C_{p,l}$	$C_{p,l}$
-0.200	-0.0233	-0.0004	0.0839	0.0839	-0.3436
-0.400	-0.0456	-0.0047	0.0418	-0.0978	-0.4388
-0.600	-0.0667	-0.0224	0.0131	-0.0816	-0.5367
-0.700	-0.0659	-0.0532	-0.0057	-0.0804	-0.6265
-0.800	-0.0483	-0.0816	-0.0460	-0.0905	-0.7094
-0.850	-0.0290	-0.0774	-0.0724	-0.1170	-0.7617
-0.900	0.0000	-0.0606	-0.0908	-0.1452	-0.7802
-0.950	0.0563	-0.0083	-0.0435	-0.1246	-0.3899
-0.975	0.0000	0.0474	0.0114	-0.0658	-0.2478
-1.000	0.2003	0.1930	0.1672	0.1484	0.0645

Medium Radius L.E.
 Run No. = 10, Point No. = 194
 $C_N = -0.003$, $C_m = -0.0025$
 $\alpha = 0.0^\circ$, $M_\infty = 0.849$
 $R_{mac} = 11.8 \times 10^6$

Leading Edge Pressures

● starboard
 ○ port

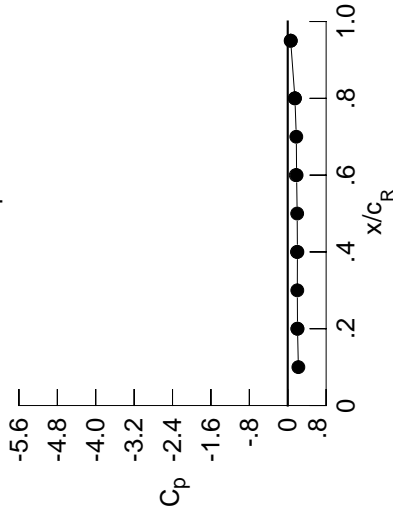

x/c_R	starb'd C_p	port C_p
0.10	0.2218	0.2003
0.20	0.2038	0.1995
0.30	0.1995	0.1930
0.40	0.2019	0.1964
0.50	0.1964	0.1672
0.60	0.1848	0.1786
0.70	0.1786	0.1498
0.80	0.1498	0.0611
0.90	0.0611	0.0645

Surface Pressures

● upper, starboard
 ○ lower, port

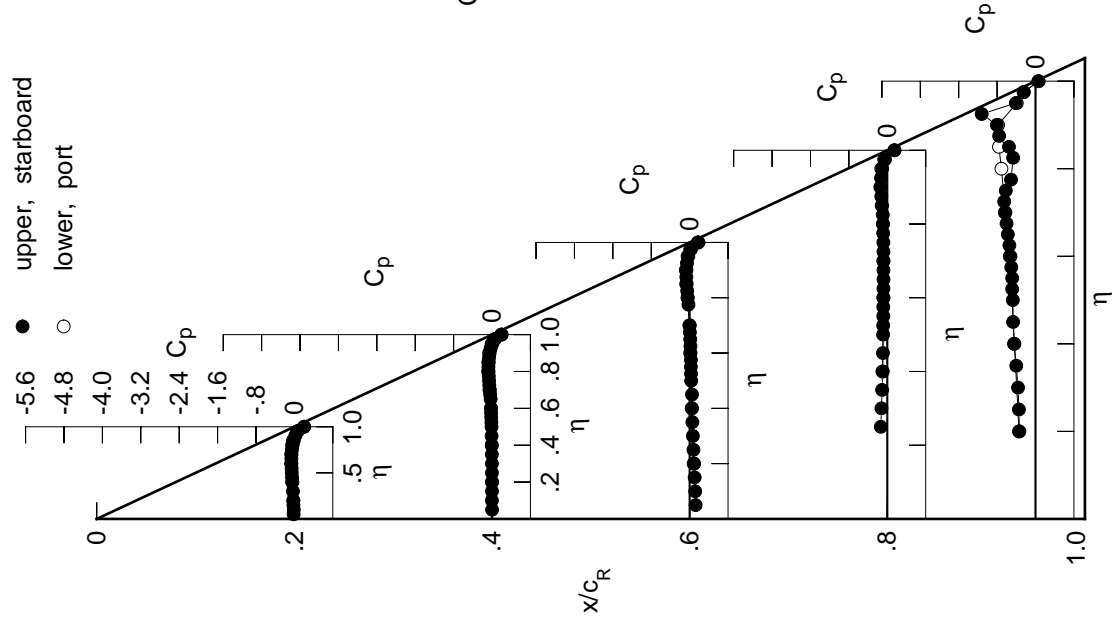

Table E2. Continued.

η	$x/c_R = .2$		$x/c_R = .4$		$x/c_R = .6$		$x/c_R = .8$		$x/c_R = .95$	
	$C_{p,u}$	$C_{p,u}$	$C_{p,u}$	$C_{p,u}$	$C_{p,u}$	$C_{p,u}$	$C_{p,u}$	$C_{p,u}$	$C_{p,u}$	$C_{p,u}$
0.050	-0.0368	-0.0168	0.1140	0.1140	0.0795	0.0795	0.0795	0.0795	0.0795	0.0795
0.100	-0.0323	-0.0188	0.1032	0.1032	0.0922	0.0922	0.0922	0.0922	0.0922	0.0922
0.150	-0.0388	-0.0186	0.0922	0.0922	0.0795	0.0795	0.0795	0.0795	0.0795	0.0795
0.200	-0.0398	-0.0170	0.0795	0.0795	0.0659	0.0659	0.0659	0.0659	0.0659	0.0659
0.250	*****	-0.0184	0.0659	0.0659	-0.1466	-0.1466	-0.1466	-0.1466	-0.1466	-0.1466
0.300	-0.0497	-0.0202	0.0541	0.0541	-0.1325	-0.1325	-0.1325	-0.1325	-0.1325	-0.1325
0.350	*****	-0.0219	0.0431	0.0431	-0.1198	-0.1198	-0.1198	-0.1198	-0.1198	-0.1198
0.400	-0.0654	-0.0242	0.0347	0.0347	-0.1104	-0.1104	-0.1104	-0.1104	-0.1104	-0.1104
0.450	-0.0725	-0.0292	0.0331	0.0331	-0.1025	-0.1025	-0.1025	-0.1025	-0.1025	-0.1025
0.500	-0.0794	-0.0315	0.0166	0.0166	-0.0992	-0.0992	-0.0992	-0.0992	-0.0992	-0.0992
0.525	*****	-0.0344	0.0131	0.0131	-0.0992	-0.0992	-0.0992	-0.0992	-0.0992	-0.0992
0.550	-0.0842	-0.0374	0.0077	0.0077	-0.0977	-0.0977	-0.0977	-0.0977	-0.0977	-0.0977
0.575	*****	-0.0420	0.0091	0.0091	-0.0966	-0.0966	-0.0966	-0.0966	-0.0966	-0.0966
0.600	-0.0914	-0.0441	-0.0011	-0.0011	-0.0971	-0.0971	-0.0971	-0.0971	-0.0971	-0.0971
0.625	*****	*****	-0.0029	-0.0029	-0.0958	-0.0958	-0.0958	-0.0958	-0.0958	-0.0958
0.650	-0.0954	-0.0533	-0.0085	-0.0085	-0.0963	-0.0963	-0.0963	-0.0963	-0.0963	-0.0963
0.675	*****	-0.0650	-0.0156	-0.0156	-0.0978	-0.0978	-0.0978	-0.0978	-0.0978	-0.0978
0.700	-0.0945	-0.0755	-0.0193	-0.0193	-0.0984	-0.0984	-0.0984	-0.0984	-0.0984	-0.0984
0.725	*****	-0.0872	*****	*****	-0.0996	-0.0996	-0.0996	-0.0996	-0.0996	-0.0996
0.750	-0.0892	-0.0950	*****	*****	-0.1024	-0.1024	-0.1024	-0.1024	-0.1024	-0.1024
0.775	*****	-0.1042	-0.0533	-0.0533	-0.1093	-0.1093	-0.1093	-0.1093	-0.1093	-0.1093
0.800	-0.0754	-0.1126	-0.0685	-0.0685	-0.1158	-0.1158	-0.1158	-0.1158	-0.1158	-0.1158
0.825	*****	-0.1169	-0.0858	-0.0858	-0.1195	-0.1195	-0.1195	-0.1195	-0.1195	-0.1195
0.850	-0.0567	-0.1153	-0.1024	-0.1024	-0.1420	-0.1420	-0.1420	-0.1420	-0.1420	-0.1420
0.875	*****	-0.1114	-0.1142	-0.1142	-0.1637	-0.1637	-0.1637	-0.1637	-0.1637	-0.1637
0.900	-0.0271	-0.1034	-0.1199	-0.1199	-0.1801	-0.1801	-0.1801	-0.1801	-0.1801	-0.1801
0.925	*****	-0.0854	-0.1147	-0.1147	-0.1847	-0.1847	-0.1847	-0.1847	-0.1847	-0.1847
0.950	0.0183	-0.0559	-0.0953	-0.0953	-0.1719	-0.1719	-0.1719	-0.1719	-0.1719	-0.1719
0.975	*****	-0.0090	-0.0469	-0.0469	-0.1235	-0.1235	-0.1235	-0.1235	-0.1235	-0.1235
1.000	0.1898	0.1795	0.1672	0.1672	0.1212	0.1212	0.0402	0.0402	0.0402	0.0402
-0.200	$C_{p,l}$	$C_{p,l}$	$C_{p,l}$	$C_{p,l}$	$C_{p,l}$	$C_{p,l}$	$C_{p,l}$	$C_{p,l}$	$C_{p,l}$	$C_{p,l}$
-0.400	-0.0019	0.0158	0.0968	0.0968	0.0968	0.0968	0.0968	0.0968	0.0968	0.0968
-0.600	-0.0229	0.0152	0.0564	0.0564	-0.0864	-0.0864	-0.0864	-0.0864	-0.0864	-0.0864
-0.700	-0.0326	-0.0241	0.0160	0.0160	-0.0630	-0.0630	-0.0630	-0.0630	-0.0630	-0.0630
-0.800	-0.0103	-0.0432	-0.0156	-0.0156	-0.0665	-0.0665	-0.0665	-0.0665	-0.0665	-0.0665
-0.850	0.0119	-0.0334	-0.0342	-0.0342	-0.0855	-0.0855	-0.0855	-0.0855	-0.0855	-0.0855
-0.900	*****	-0.0101	-0.0318	-0.0318	-0.1012	-0.1012	-0.1012	-0.1012	-0.1012	-0.1012
-0.950	0.1006	0.0476	0.0158	0.0158	-0.0650	-0.0650	-0.0650	-0.0650	-0.0650	-0.0650
-0.975	*****	0.1045	0.0745	0.0745	0.0010	0.0010	-0.1975	-0.1975	-0.1975	-0.1975
-1.000	0.1934	0.1818	0.1505	0.1505	0.1355	0.1355	0.0578	0.0578	0.0578	0.0578

Medium Radius L.E.
 Run No. = 10 , Point No. = 195
 $C_N = 0.040$, $C_m = -0.0102$
 $\alpha = 1.0^\circ$, $M_\infty = 0.849$
 $R_{mac} = 11.8 \times 10^6$

Leading Edge Pressures

● starboard
 ○ port

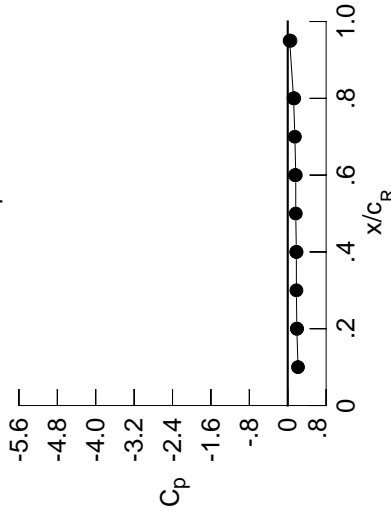

x/c_R	starb'd C_p	port C_p
0.10	0.2139	*****
0.20	0.1898	0.1934
0.30	0.1806	*****
0.40	0.1795	0.1818
0.50	0.1669	*****
0.60	0.1672	0.1505
0.70	0.1490	*****
0.80	0.1212	0.1355
0.90	*****	*****
0.95	0.0402	0.0578

Surface Pressures

● upper, starboard
 ○ lower, port

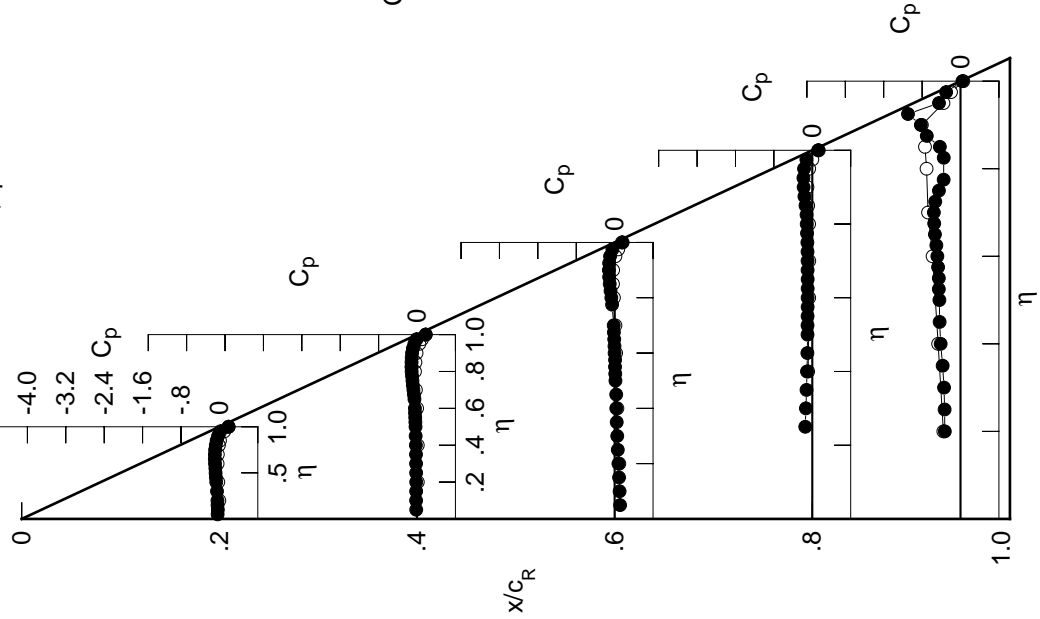

Table E2. Continued.

η	$x/c_R = .2$		$x/c_R = .4$		$x/c_R = .6$		$x/c_R = .8$		$x/c_R = .95$	
	$C_{p,u}$	$C_{p,u}$	$C_{p,u}$	$C_{p,u}$	$C_{p,u}$	$C_{p,u}$	$C_{p,u}$	$C_{p,u}$	$C_{p,u}$	$C_{p,u}$
0.050	-0.0558	-0.0359	0.1022	*****	*****	*****	*****	*****	*****	*****
0.100	-0.0521	-0.0351	0.0918	*****	*****	*****	*****	*****	*****	*****
0.150	-0.0575	-0.0379	0.0798	*****	*****	*****	*****	*****	*****	*****
0.200	-0.0602	-0.0340	0.0666	*****	*****	*****	*****	*****	*****	*****
0.250	*****	-0.0381	0.0528	-0.1584	-0.3218	*****	*****	*****	*****	*****
0.300	-0.0717	-0.0386	0.0410	-0.1452	-0.3276	*****	*****	*****	*****	*****
0.350	*****	-0.0413	0.0288	-0.1326	-0.3519	*****	*****	*****	*****	*****
0.400	-0.0886	-0.0440	0.0195	-0.1230	-0.3902	*****	*****	*****	*****	*****
0.450	-0.0977	-0.0504	0.0174	-0.1162	-0.4124	*****	*****	*****	*****	*****
0.500	-0.1061	-0.0533	0.0006	-0.1131	-0.4197	*****	*****	*****	*****	*****
0.525	*****	-0.0561	-0.0042	-0.1140	-0.4295	*****	*****	*****	*****	*****
0.550	-0.1133	-0.0626	-0.0103	-0.1127	-0.4312	*****	*****	*****	*****	*****
0.575	*****	-0.0645	-0.0091	-0.1114	-0.4449	*****	*****	*****	*****	*****
0.600	-0.1226	-0.0693	-0.0194	-0.1128	-0.4580	*****	*****	*****	*****	*****
0.625	*****	*****	-0.0223	-0.1129	-0.4730	*****	*****	*****	*****	*****
0.650	-0.1285	-0.0830	-0.0299	-0.1143	-0.4916	*****	*****	*****	*****	*****
0.675	*****	-0.0937	-0.0373	-0.1164	-0.4839	*****	*****	*****	*****	*****
0.700	-0.1321	-0.1074	-0.0413	-0.1196	-0.4560	*****	*****	*****	*****	*****
0.725	*****	-0.1213	*****	-0.1215	-0.4077	*****	*****	*****	*****	*****
0.750	-0.1295	-0.1318	*****	-0.1257	-0.3398	*****	*****	*****	*****	*****
0.775	*****	-0.1439	-0.0842	-0.1349	-0.2597	*****	*****	*****	*****	*****
0.800	-0.1192	-0.1558	-0.1032	-0.1442	*****	*****	*****	*****	*****	*****
0.825	*****	-0.1657	-0.1266	-0.1501	-0.2847	*****	*****	*****	*****	*****
0.850	-0.1045	-0.1673	-0.1477	-0.1788	-0.3274	*****	*****	*****	*****	*****
0.875	*****	-0.1693	-0.1678	-0.2070	-0.5271	*****	*****	*****	*****	*****
0.900	-0.0795	-0.1651	-0.1805	-0.2334	-0.7844	*****	*****	*****	*****	*****
0.925	*****	-0.1548	-0.1832	-0.2497	-1.0644	*****	*****	*****	*****	*****
0.950	-0.0406	-0.1314	-0.1752	-0.2493	-0.4925	*****	*****	*****	*****	*****
0.975	*****	-0.0957	-0.1407	-0.2183	-0.3711	*****	*****	*****	*****	*****
1.000	0.1471	0.1040	0.0709	0.0167	-0.0369	*****	*****	*****	*****	*****
-0.200	$C_{p,l}$	$C_{p,l}$	$C_{p,l}$	$C_{p,l}$	$C_{p,l}$	$C_{p,l}$	$C_{p,l}$	$C_{p,l}$	$C_{p,l}$	$C_{p,l}$
-0.400	0.0193	0.0351	0.1103	*****	-0.3766	*****	*****	*****	*****	*****
-0.600	0.0013	0.0354	0.0724	-0.0726	-0.5038	*****	*****	*****	*****	*****
-0.700	-0.0073	0.0250	0.0502	-0.0498	-0.6401	*****	*****	*****	*****	*****
-0.800	0.0020	0.0056	0.0393	-0.0441	-0.7076	*****	*****	*****	*****	*****
-0.850	0.0285	-0.0053	0.0155	-0.0420	-0.6942	*****	*****	*****	*****	*****
-0.900	0.0518	0.0096	0.0048	-0.0635	-0.7171	*****	*****	*****	*****	*****
-0.950	*****	0.0381	0.0149	-0.0584	-0.7655	*****	*****	*****	*****	*****
-0.975	0.1404	0.0973	0.0700	-0.0103	-0.3242	*****	*****	*****	*****	*****
-1.000	0.1561	0.1175	0.0604	0.0457	-0.0037	*****	*****	*****	*****	*****

Medium Radius L.E.
 Run No. = 10, Point No. = 196
 $C_N = 0.084$, $C_m = -0.0180$
 $\alpha = 2.1^\circ$, $M_\infty = 0.849$
 $R_{mac} = 11.8 \times 10^6$

Leading Edge Pressures

● starboard
 ○ port

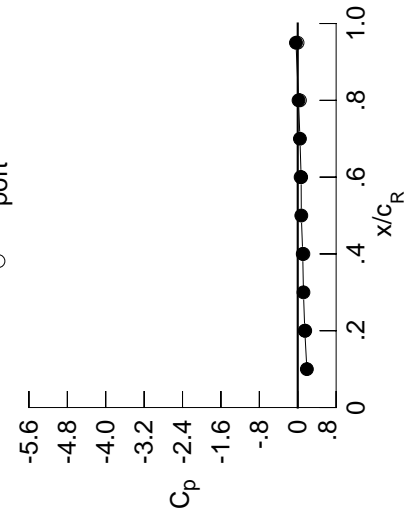

x/c_R	starb'd C_p	port C_p
0.10	0.1904	*****
0.20	0.1471	0.1561
0.30	0.1190	*****
0.40	0.1040	0.1175
0.50	0.0747	*****
0.60	0.0709	0.0604
0.70	0.0459	*****
0.80	0.0167	0.0457
0.90	*****	*****
0.95	-0.0369	-0.0037

Surface Pressures

● upper, starboard
 ○ lower, port

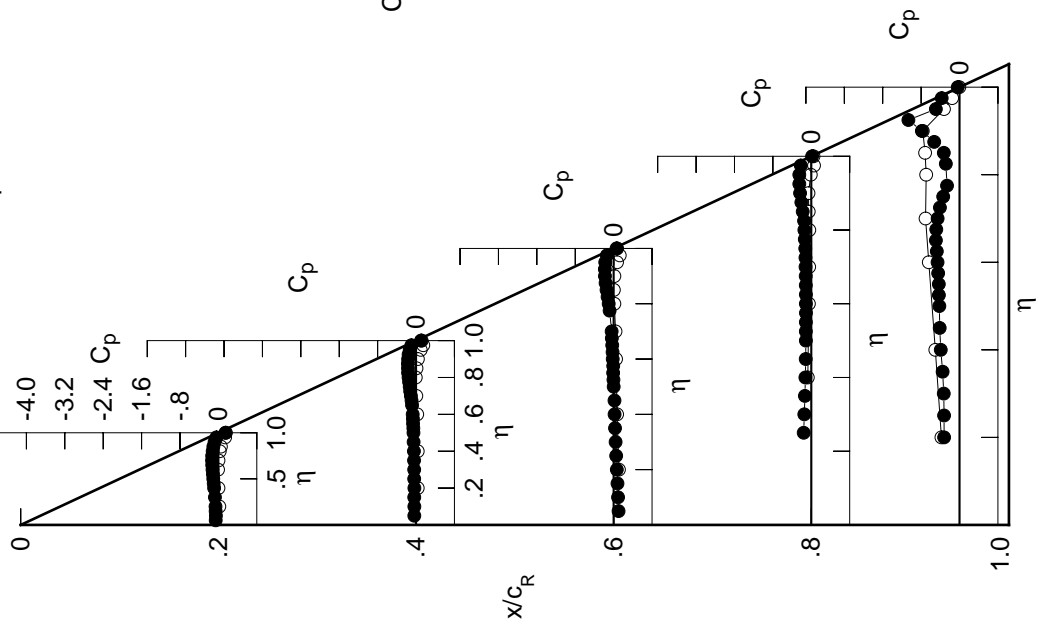
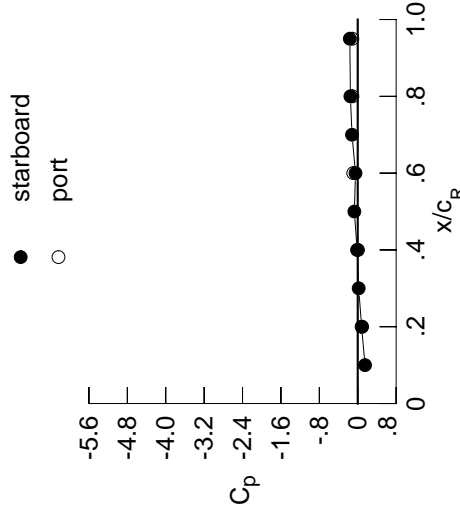

Table E2. Continued.

η	$x/c_R = .2$		$x/c_R = .4$		$x/c_R = .6$		$x/c_R = .8$		$x/c_R = .95$	
	$C_{p,u}$	$C_{p,u}$	$C_{p,u}$	$C_{p,u}$	$C_{p,u}$	$C_{p,u}$	$C_{p,u}$	$C_{p,u}$	$C_{p,u}$	$C_{p,u}$
0.050	-0.0735	-0.0516	0.0897	0.0897	0.0897	0.0897	0.0897	0.0897	0.0897	0.0897
0.100	-0.0704	-0.0523	0.0800	0.0800	0.0800	0.0800	0.0800	0.0800	0.0800	0.0800
0.150	-0.0773	-0.0540	0.0671	0.0671	0.0671	0.0671	0.0671	0.0671	0.0671	0.0671
0.200	-0.0791	-0.0519	0.0536	0.0536	0.0536	0.0536	0.0536	0.0536	0.0536	0.0536
0.250	0.0000	-0.0550	0.0394	0.0394	-0.1702	-0.1702	-0.3131	-0.3131	-0.3131	-0.3131
0.300	-0.0907	-0.0571	0.0271	0.0271	-0.1571	-0.1571	-0.3135	-0.3135	-0.3135	-0.3135
0.350	0.0000	-0.0595	0.0154	0.0154	-0.1444	-0.1444	-0.3313	-0.3313	-0.3313	-0.3313
0.400	-0.1100	-0.0639	0.0053	0.0053	-0.1361	-0.1361	-0.3649	-0.3649	-0.3649	-0.3649
0.450	-0.1211	-0.0699	0.0022	0.0022	-0.1295	-0.1295	-0.3889	-0.3889	-0.3889	-0.3889
0.500	-0.1320	-0.0746	-0.0156	-0.0156	-0.1273	-0.1273	-0.4004	-0.4004	-0.4004	-0.4004
0.525	0.0000	-0.0793	-0.0213	-0.0213	-0.1274	-0.1274	-0.4114	-0.4114	-0.4114	-0.4114
0.550	-0.1408	-0.0836	-0.0266	-0.0266	-0.1273	-0.1273	-0.4118	-0.4118	-0.4118	-0.4118
0.575	0.0000	-0.0894	-0.0279	-0.0279	-0.1260	-0.1260	-0.4235	-0.4235	-0.4235	-0.4235
0.600	-0.1520	-0.0928	-0.0384	-0.0384	-0.1294	-0.1294	-0.4331	-0.4331	-0.4331	-0.4331
0.625	0.0000	0.0000	-0.0422	-0.0422	-0.1282	-0.1282	-0.4397	-0.4397	-0.4397	-0.4397
0.650	-0.1622	-0.1094	-0.0505	-0.0505	-0.1307	-0.1307	-0.4421	-0.4421	-0.4421	-0.4421
0.675	0.0000	-0.1220	-0.0602	-0.0602	-0.1346	-0.1346	-0.4194	-0.4194	-0.4194	-0.4194
0.700	-0.1681	-0.1376	-0.0657	-0.0657	-0.1381	-0.1381	-0.3885	-0.3885	-0.3885	-0.3885
0.725	0.0000	-0.1528	0.0000	0.0000	-0.1427	-0.1427	-0.3486	-0.3486	-0.3486	-0.3486
0.750	-0.1690	-0.1681	0.0000	0.0000	-0.1481	-0.1481	-0.2864	-0.2864	-0.2864	-0.2864
0.775	0.0000	-0.1821	-0.1141	-0.1141	-0.1602	-0.1602	-0.2166	-0.2166	-0.2166	-0.2166
0.800	-0.1633	-0.2001	-0.1374	-0.1374	-0.1718	-0.1718	0.0000	0.0000	0.0000	0.0000
0.825	0.0000	-0.2120	-0.1641	-0.1641	-0.1803	-0.1803	-0.2523	-0.2523	-0.2523	-0.2523
0.850	-0.1533	-0.2200	-0.1928	-0.1928	-0.2152	-0.2152	-0.2747	-0.2747	-0.2747	-0.2747
0.875	0.0000	-0.2277	-0.2203	-0.2203	-0.2504	-0.2504	-0.4039	-0.4039	-0.4039	-0.4039
0.900	-0.1340	-0.2299	-0.2424	-0.2424	-0.2885	-0.2885	-0.6636	-0.6636	-0.6636	-0.6636
0.925	0.0000	-0.2266	-0.2545	-0.2545	-0.3144	-0.3144	-1.0118	-1.0118	-1.0118	-1.0118
0.950	-0.1040	-0.2103	-0.2600	-0.2600	-0.3310	-0.3310	-0.5417	-0.5417	-0.5417	-0.5417
0.975	0.0000	-0.1921	-0.2452	-0.2452	-0.3224	-0.3224	-0.4481	-0.4481	-0.4481	-0.4481
1.000	0.0807	-0.0133	-0.0466	-0.0466	-0.1527	-0.1527	-0.1649	-0.1649	-0.1649	-0.1649
-0.200	$C_{p,l}$	$C_{p,l}$	$C_{p,l}$	$C_{p,l}$	$C_{p,l}$	$C_{p,l}$	$C_{p,l}$	$C_{p,l}$	$C_{p,l}$	$C_{p,l}$
-0.400	0.0394	0.0531	0.1230	0.1230	0.0000	0.0000	-0.3919	-0.3919	-0.3919	-0.3919
-0.600	0.0244	0.0553	0.0875	0.0875	0.0601	0.0601	-0.5352	-0.5352	-0.5352	-0.5352
-0.700	0.0208	0.0478	0.0688	0.0688	0.0350	0.0350	-0.6765	-0.6765	-0.6765	-0.6765
-0.800	0.0327	0.0325	0.0592	0.0592	-0.0266	-0.0266	-0.7182	-0.7182	-0.7182	-0.7182
-0.850	0.0627	0.0293	0.0429	0.0429	-0.0195	-0.0195	-0.6793	-0.6793	-0.6793	-0.6793
-0.900	0.0870	0.0472	0.0381	0.0381	-0.0256	-0.0256	-0.6960	-0.6960	-0.6960	-0.6960
-0.950	0.1720	0.1371	0.0546	0.0546	-0.0207	-0.0207	-0.7270	-0.7270	-0.7270	-0.7270
-0.975	0.0000	0.1826	0.1626	0.1626	0.0334	0.0334	-0.2987	-0.2987	-0.2987	-0.2987
-1.000	0.0918	0.0060	-0.0932	-0.0932	-0.1100	-0.1100	-0.1122	-0.1122	-0.1122	-0.1122

Medium Radius L.E.
 Run No. = 10 , Point No. = 197
 $C_N = 0.122$, $C_m = -0.0228$
 $\alpha = 3.1^\circ$, $M_\infty = 0.849$
 $R_{mac} = 11.8 \times 10^6$

Leading Edge Pressures



x/c_R	starb'd C_p	port C_p
0.10	0.1519	0.0918
0.20	0.0807	0.0203
0.30	0.0203	0.0060
0.40	-0.0133	0.0060
0.50	-0.0701	0.0060
0.60	-0.0466	-0.0932
0.70	-0.1193	0.0060
0.80	-0.1527	-0.1100
0.90	0.0000	0.0060
0.95	-0.1649	-0.1122

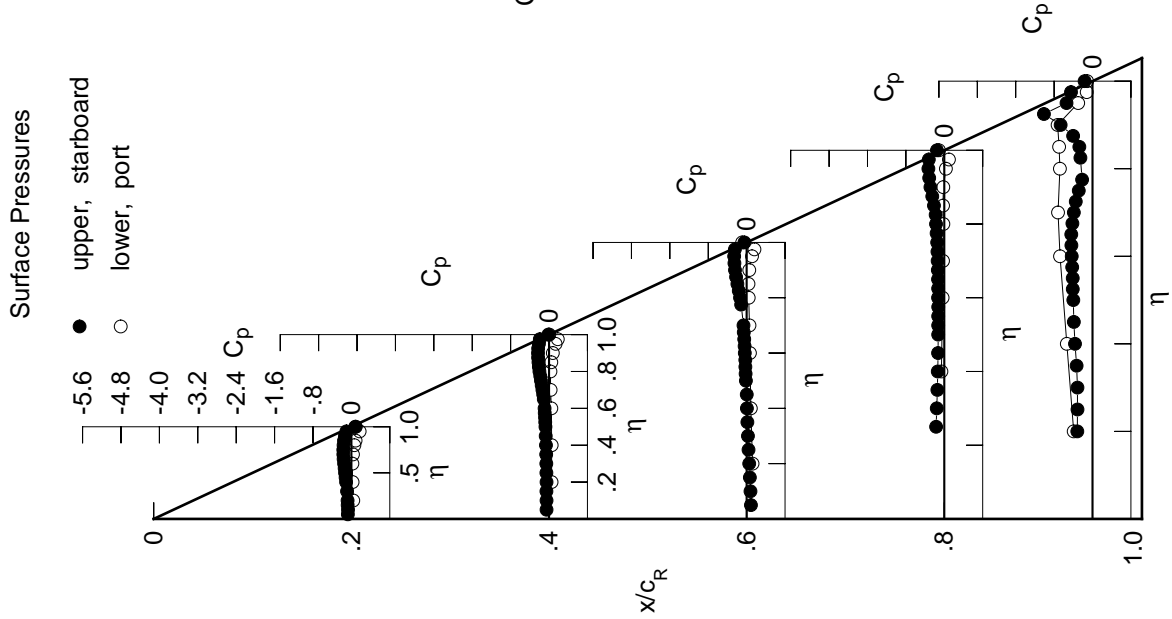
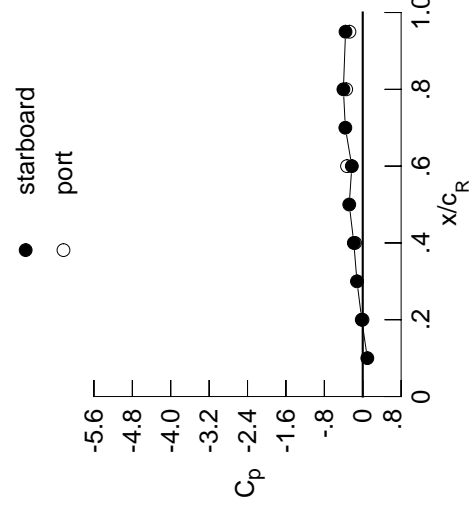

Table E2. Continued.

η	$x/c_R = .2$		$x/c_R = .4$		$x/c_R = .6$		$x/c_R = .8$		$x/c_R = .95$	
	$C_{p,u}$	$C_{p,u}$	$C_{p,u}$	$C_{p,u}$	$C_{p,u}$	$C_{p,u}$	$C_{p,u}$	$C_{p,u}$	$C_{p,u}$	$C_{p,u}$
0.050	-0.0935	-0.0689	0.0779	*****	*****	*****	*****	*****	*****	
0.100	-0.0900	-0.0687	0.0677	*****	*****	*****	*****	*****	*****	
0.150	-0.0969	-0.0712	0.0552	*****	*****	*****	*****	*****	*****	
0.200	-0.0993	-0.0697	0.0416	*****	*****	*****	*****	*****	-0.3126	
0.250	*****	-0.0733	0.0273	-0.1821	-0.3059	*****	*****	*****	*****	
0.300	-0.1118	-0.0759	0.0144	-0.1685	-0.3032	*****	*****	*****	*****	
0.350	*****	-0.0783	0.0025	-0.1568	-0.3165	*****	*****	*****	*****	
0.400	-0.1343	-0.0837	-0.0099	-0.1475	-0.3467	*****	*****	*****	*****	
0.450	-0.1456	-0.0913	-0.0137	-0.1420	-0.3728	*****	*****	*****	*****	
0.500	-0.1584	-0.0971	-0.0325	-0.1407	-0.3893	*****	*****	*****	*****	
0.525	*****	-0.1003	-0.0378	-0.1422	-0.4012	*****	*****	*****	*****	
0.550	-0.1714	-0.1083	-0.0459	-0.1412	-0.4006	*****	*****	*****	*****	
0.575	*****	-0.1139	-0.0462	-0.1431	-0.4119	*****	*****	*****	*****	
0.600	-0.1841	-0.1196	-0.0592	-0.1446	-0.4148	*****	*****	*****	*****	
0.625	*****	*****	-0.0627	-0.1457	-0.4169	*****	*****	*****	*****	
0.650	-0.1975	-0.1380	-0.0730	-0.1494	-0.4111	*****	*****	*****	*****	
0.675	*****	-0.1531	-0.0836	-0.1543	-0.3909	*****	*****	*****	*****	
0.700	-0.2067	-0.1705	-0.0927	-0.1599	-0.3675	*****	*****	*****	*****	
0.725	*****	-0.1893	*****	-0.1655	-0.3320	*****	*****	*****	*****	
0.750	-0.2121	-0.2067	*****	-0.1740	-0.2704	*****	*****	*****	*****	
0.775	*****	-0.2262	-0.1470	-0.1874	-0.2097	*****	*****	*****	*****	
0.800	-0.2107	-0.2466	-0.1733	-0.2020	*****	*****	*****	*****	*****	
0.825	*****	-0.2652	-0.2065	-0.2147	-0.2447	*****	*****	*****	*****	
0.850	-0.2072	-0.2784	-0.2422	-0.2534	-0.2625	*****	*****	*****	*****	
0.875	*****	-0.2923	-0.2775	-0.2980	-0.3560	*****	*****	*****	*****	
0.900	-0.1954	-0.3012	-0.3114	-0.3461	-0.5846	*****	*****	*****	*****	
0.925	*****	-0.3080	-0.3375	-0.3888	-0.9077	*****	*****	*****	*****	
0.950	-0.1774	-0.3037	-0.3595	-0.4245	-0.5979	*****	*****	*****	*****	
0.975	*****	-0.3061	-0.3701	-0.4472	-0.5449	*****	*****	*****	*****	
1.000	-0.0200	-0.1856	-0.2270	-0.4026	-0.3582	*****	*****	*****	*****	
-0.200	$C_{p,l}$	$C_{p,l}$	$C_{p,l}$	$C_{p,l}$	$C_{p,l}$	$C_{p,l}$	$C_{p,l}$	$C_{p,l}$	$C_{p,l}$	
-0.400	0.0614	0.0727	0.1391	*****	*****	*****	*****	*****	-0.4106	
-0.600	0.0490	0.0747	0.1023	-0.0461	-0.5747	*****	*****	*****	*****	
-0.700	0.0500	0.0711	0.0865	-0.0192	-0.7011	*****	*****	*****	*****	
-0.800	0.0649	0.0606	0.0800	-0.0080	-0.7144	*****	*****	*****	*****	
-0.850	0.0975	0.0635	0.0702	0.0025	-0.6630	*****	*****	*****	*****	
-0.900	0.1216	0.0842	0.0716	0.0023	-0.6748	*****	*****	*****	*****	
-0.950	0.1981	0.1696	0.0918	0.0148	-0.6912	*****	*****	*****	*****	
-0.975	*****	0.2034	0.1870	0.1275	-0.0943	*****	*****	*****	*****	
-1.000	-0.0046	-0.1616	-0.3270	-0.3450	-0.2765	*****	*****	*****	*****	

Medium Radius L.E.
 Run No. = 10, Point No. = 198
 $C_N = 0.166$, $C_m = -0.0303$
 $\alpha = 4.2^\circ$, $M_\infty = 0.849$
 $R_{mac} = 11.7 \times 10^6$

Leading Edge Pressures



x/c_R	starb'd C_p	port C_p
0.10	0.0960	*****
0.20	-0.0200	-0.0046
0.30	-0.1201	*****
0.40	-0.1856	-0.1616
0.50	-0.2812	*****
0.60	-0.2270	-0.3270
0.70	-0.3623	*****
0.80	-0.4026	-0.3450
0.90	*****	*****
0.95	-0.3582	-0.2765

Surface Pressures

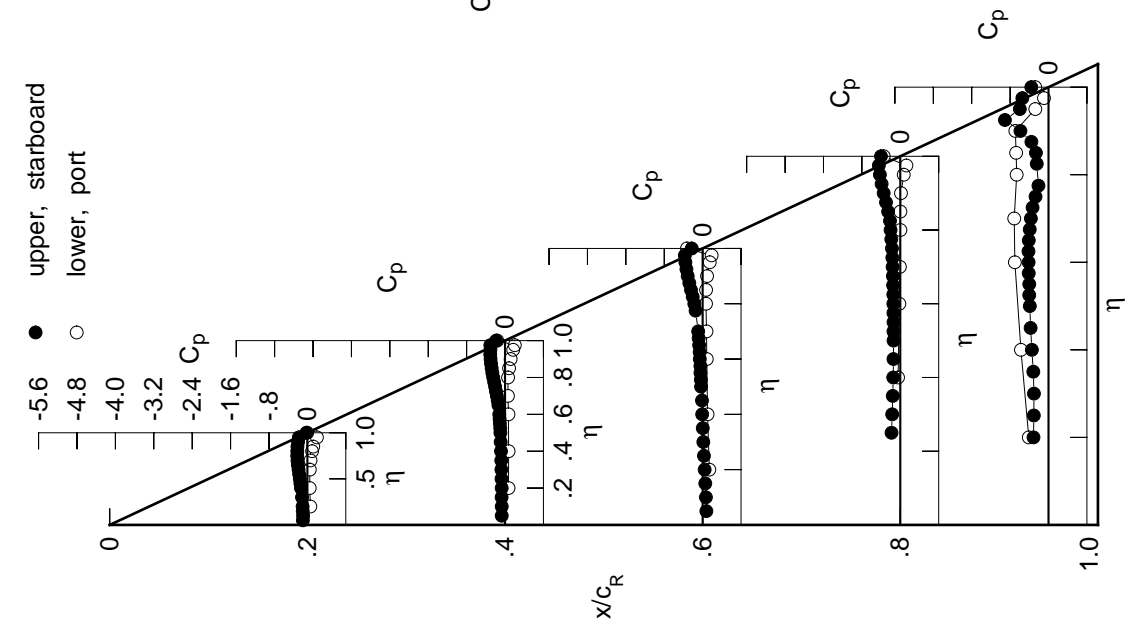

Table E2. Continued.

η	$x/c_R = .2$		$x/c_R = .4$		$x/c_R = .6$		$x/c_R = .8$		$x/c_R = .95$	
	$C_{p,u}$	$C_{p,u}$	$C_{p,u}$	$C_{p,u}$	$C_{p,u}$	$C_{p,u}$	$C_{p,u}$	$C_{p,u}$	$C_{p,u}$	$C_{p,u}$
0.050	-0.1102	-0.0848	0.0682	*****	*****	*****	*****	*****	*****	
0.100	-0.1083	-0.0857	0.0569	*****	*****	*****	*****	*****	*****	
0.150	-0.1147	-0.0884	0.0444	*****	*****	*****	*****	*****	*****	
0.200	-0.1178	-0.0853	0.0309	*****	*****	*****	*****	*****	-0.3093	
0.250	*****	-0.0909	0.0156	-0.1927	-0.1927	-0.1927	-0.1927	-0.1927	-0.2985	
0.300	-0.1324	-0.0924	0.0016	-0.1791	-0.1791	-0.1791	-0.1791	-0.1791	-0.2935	
0.350	*****	-0.0971	-0.0108	-0.1675	-0.1675	-0.1675	-0.1675	-0.1675	-0.3026	
0.400	-0.1564	-0.1028	-0.0230	-0.1596	-0.1596	-0.1596	-0.1596	-0.1596	-0.3321	
0.450	-0.1695	-0.1111	-0.0282	-0.1544	-0.1544	-0.1544	-0.1544	-0.1544	-0.3598	
0.500	-0.1838	-0.1182	-0.0491	-0.1539	-0.1539	-0.1539	-0.1539	-0.1539	-0.3839	
0.525	*****	-0.1236	-0.0543	-0.1550	-0.1550	-0.1550	-0.1550	-0.1550	-0.3999	
0.550	-0.1984	-0.1316	-0.0613	-0.1555	-0.1555	-0.1555	-0.1555	-0.1555	-0.4027	
0.575	*****	-0.1376	-0.0639	-0.1574	-0.1574	-0.1574	-0.1574	-0.1574	-0.4145	
0.600	-0.2152	-0.1443	-0.0784	-0.1606	-0.1606	-0.1606	-0.1606	-0.1606	-0.4161	
0.625	*****	*****	-0.0838	-0.1629	-0.1629	-0.1629	-0.1629	-0.1629	-0.4161	
0.650	-0.2319	-0.1660	-0.0954	-0.1673	-0.1673	-0.1673	-0.1673	-0.1673	-0.4096	
0.675	*****	-0.1819	-0.1066	-0.1731	-0.1731	-0.1731	-0.1731	-0.1731	-0.3910	
0.700	-0.2451	-0.2022	-0.1170	-0.1811	-0.1811	-0.1811	-0.1811	-0.1811	-0.3708	
0.725	*****	-0.2241	*****	-0.1878	-0.1878	-0.1878	-0.1878	-0.1878	-0.3334	
0.750	-0.2547	-0.2447	*****	-0.1997	-0.1997	-0.1997	-0.1997	-0.1997	-0.2685	
0.775	*****	-0.2674	-0.1787	-0.2143	-0.2143	-0.2143	-0.2143	-0.2143	-0.2132	
0.800	-0.2611	-0.2932	-0.2094	-0.2334	*****	*****	*****	*****	*****	
0.825	*****	-0.3181	-0.2469	-0.2481	-0.2481	-0.2481	-0.2481	-0.2481	-0.2459	
0.850	-0.2630	-0.3365	-0.2895	-0.2908	-0.2908	-0.2908	-0.2908	-0.2908	-0.2616	
0.875	*****	-0.3581	-0.3353	-0.3429	-0.3429	-0.3429	-0.3429	-0.3429	-0.3302	
0.900	-0.2594	-0.3749	-0.3816	-0.4028	-0.4028	-0.4028	-0.4028	-0.4028	-0.5415	
0.925	*****	-0.3942	-0.4194	-0.4604	-0.4604	-0.4604	-0.4604	-0.4604	-0.7109	
0.950	-0.2561	-0.4025	-0.4635	-0.5202	-0.5202	-0.5202	-0.5202	-0.5202	-0.6613	
0.975	*****	-0.4304	-0.5113	-0.5807	-0.5807	-0.5807	-0.5807	-0.5807	-0.6516	
1.000	-0.1399	-0.3972	-0.4387	-0.7056	-0.7056	-0.7056	-0.7056	-0.7056	-0.6033	
	$C_{p,l}$	$C_{p,l}$	$C_{p,l}$	$C_{p,l}$	$C_{p,l}$	$C_{p,l}$	$C_{p,l}$	$C_{p,l}$	$C_{p,l}$	
-0.200	0.0836	0.0928	0.1536	*****	*****	*****	*****	*****	-0.4265	
-0.400	0.0730	0.0957	0.1192	-0.0320	-0.0320	-0.0320	-0.0320	-0.0320	-0.6080	
-0.600	0.0781	0.0940	0.1059	-0.0036	-0.0036	-0.0036	-0.0036	-0.0036	-0.7075	
-0.700	0.0954	0.0871	0.1023	0.0086	0.0086	0.0086	0.0086	0.0086	-0.7044	
-0.800	0.1281	0.0945	0.0960	0.0241	0.0241	0.0241	0.0241	0.0241	-0.6474	
-0.850	0.1518	0.1169	0.1009	0.0270	0.0270	0.0270	0.0270	0.0270	-0.6553	
-0.900	*****	0.1508	0.1249	0.0451	0.0451	0.0451	0.0451	0.0451	-0.6602	
-0.950	0.2165	0.1950	0.1749	0.1023	0.1023	0.1023	0.1023	0.1023	-0.2565	
-0.975	*****	0.2128	0.1990	0.1449	0.1449	0.1449	0.1449	0.1449	-0.0767	
-1.000	-0.1247	-0.3684	-0.6133	-0.6396	-0.6396	-0.6396	-0.6396	-0.6396	-0.4807	

Medium Radius L.E.
 Run No. = 10 , Point No. = 199
 $C_N = 0.210$, $C_m = -0.0382$
 $\alpha = 5.3^\circ$, $M_\infty = 0.849$
 $R_{mac} = 11.7 \times 10^6$

Leading Edge Pressures

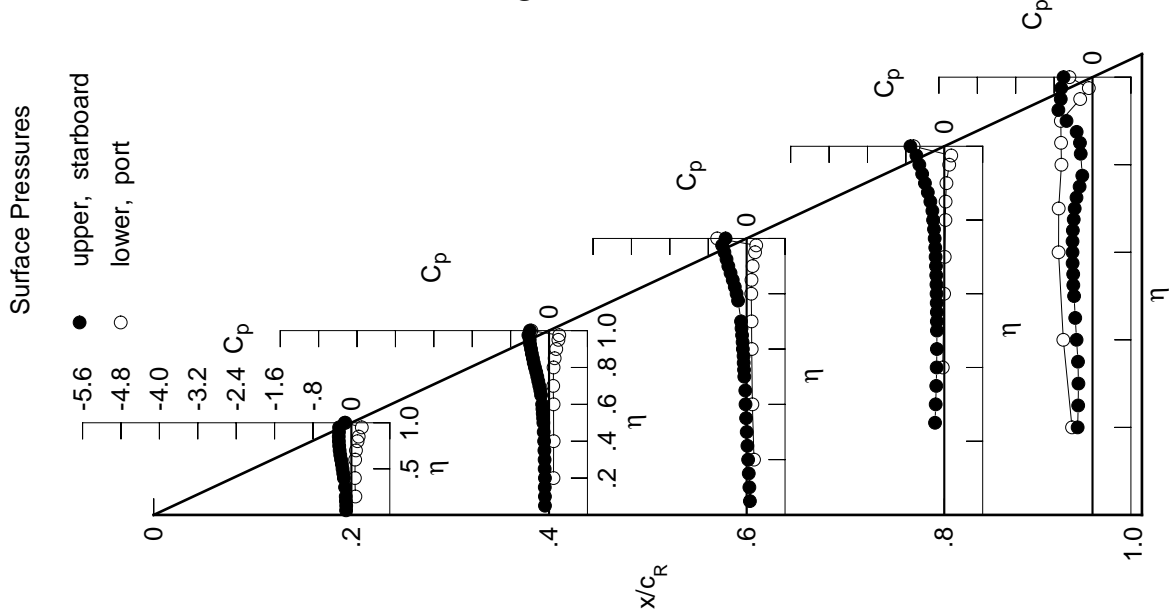
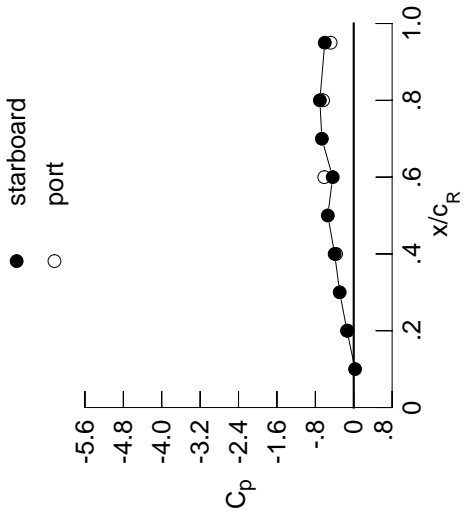

Table E2. Continued.

η	$x/c_R = .2$		$x/c_R = .4$		$x/c_R = .6$		$x/c_R = .8$		$x/c_R = .95$	
	$C_{p,u}$	$C_{p,u}$	$C_{p,u}$	$C_{p,u}$	$C_{p,u}$	$C_{p,u}$	$C_{p,u}$	$C_{p,u}$	$C_{p,u}$	$C_{p,u}$
0.050	-0.1266	-0.0993	0.0572	*****	*****	*****	*****	*****	*****	*****
0.100	-0.1252	-0.1012	0.0455	*****	*****	*****	*****	*****	*****	*****
0.150	-0.1341	-0.1036	0.0336	*****	*****	*****	*****	*****	*****	*****
0.200	-0.1366	-0.1020	0.0185	*****	*****	*****	*****	*****	*****	-0.3078
0.250	*****	-0.1058	0.0038	-0.2039	-0.1900	-0.2840	*****	*****	*****	*****
0.300	-0.1520	-0.1103	-0.0104	-0.1900	-0.1784	-0.2898	*****	*****	*****	*****
0.350	*****	-0.1144	-0.0242	-0.1784	-0.1718	-0.3154	*****	*****	*****	*****
0.400	-0.1777	-0.1212	-0.0364	-0.1718	-0.1654	-0.3448	*****	*****	*****	*****
0.450	-0.1928	-0.1316	-0.0434	-0.1654	-0.1673	-0.3778	*****	*****	*****	*****
0.500	-0.2095	-0.1412	-0.0648	-0.1673	-0.1681	-0.4030	*****	*****	*****	*****
0.525	*****	-0.1473	-0.0713	-0.1681	-0.1700	-0.4232	*****	*****	*****	*****
0.550	-0.2261	-0.1553	-0.0798	-0.1700	-0.1719	-0.4600	*****	*****	*****	*****
0.575	*****	-0.1625	-0.0829	-0.1719	-0.1755	-0.4846	*****	*****	*****	*****
0.600	-0.2462	-0.1711	-0.0980	-0.1755	-0.1786	-0.5033	*****	*****	*****	*****
0.625	*****	*****	-0.1054	-0.1786	-0.1851	-0.5185	*****	*****	*****	*****
0.650	-0.2667	-0.1960	-0.1195	-0.1851	-0.1940	-0.5012	*****	*****	*****	*****
0.675	*****	-0.2132	-0.1334	-0.1940	-0.2064	-0.4796	*****	*****	*****	*****
0.700	-0.2838	-0.2355	-0.1468	-0.2064	-0.2182	-0.4601	*****	*****	*****	*****
0.725	*****	-0.2582	*****	-0.2182	-0.2373	-0.4317	*****	*****	*****	*****
0.750	-0.2993	-0.2834	*****	-0.2373	-0.2593	-0.3785	*****	*****	*****	*****
0.775	*****	-0.3104	-0.2155	-0.2593	-0.2777	*****	*****	*****	*****	*****
0.800	-0.3106	-0.3422	-0.2483	-0.2777	-0.2962	-0.3463	*****	*****	*****	*****
0.825	*****	-0.3720	-0.2878	-0.2962	-0.3286	-0.2947	*****	*****	*****	*****
0.850	-0.3216	-0.3970	-0.3361	-0.3286	-0.3793	-0.2844	*****	*****	*****	*****
0.875	*****	-0.4266	-0.3913	-0.3793	-0.4470	-0.2986	*****	*****	*****	*****
0.900	-0.3268	-0.4549	-0.4495	-0.4470	-0.5090	-0.2987	*****	*****	*****	*****
0.925	*****	-0.4865	-0.5090	-0.5236	-0.6117	-0.5970	*****	*****	*****	*****
0.950	-0.3422	-0.5121	-0.5752	-0.6117	-0.7197	-0.7578	*****	*****	*****	*****
0.975	*****	-0.5721	-0.6493	-0.7197	-0.9778	-0.8595	*****	*****	*****	*****
1.000	-0.2882	-0.6580	-0.6577	-0.9778	*****	*****	*****	*****	*****	*****
-0.200	$C_{p,l}$	$C_{p,l}$	$C_{p,l}$	$C_{p,l}$	$C_{p,l}$	$C_{p,l}$	$C_{p,l}$	$C_{p,l}$	$C_{p,l}$	$C_{p,l}$
-0.400	0.1069	0.1125	0.1685	*****	-0.4394	*****	*****	*****	*****	*****
-0.600	0.0979	0.1165	0.1365	-0.0169	-0.6301	*****	*****	*****	*****	*****
-0.700	0.1062	0.1181	0.1237	0.0126	-0.6992	*****	*****	*****	*****	*****
-0.800	0.1256	0.1139	0.1230	0.0263	-0.6914	*****	*****	*****	*****	*****
-0.850	0.1583	0.1249	0.1212	0.0441	-0.6310	*****	*****	*****	*****	*****
-0.900	0.1805	0.1483	0.1281	0.0505	-0.6367	*****	*****	*****	*****	*****
-0.950	*****	0.1803	0.1535	0.0720	-0.6337	*****	*****	*****	*****	*****
-0.975	0.2309	0.2136	0.1953	0.1263	-0.2415	*****	*****	*****	*****	*****
-1.000	*****	0.2125	0.2018	0.1534	-0.0685	*****	*****	*****	*****	*****
	-0.2751	-0.6238	-0.8763	-0.9119	-0.7364	*****	*****	*****	*****	*****

Medium Radius L.E.
 Run No. = 10, Point No. = 200
 $C_N = 0.255$, $C_m = -0.0470$
 $\alpha = 6.3^\circ$, $M_\infty = 0.849$
 $R_{mac} = 11.7 \times 10^6$

Leading Edge Pressures

● starboard
 ○ port

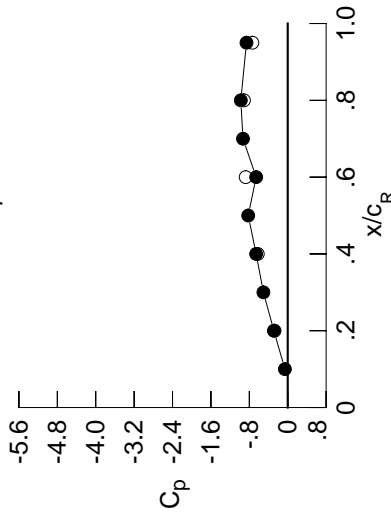

x/c_R	starb'd C_p	port C_p
0.10	-0.0591	*****
0.20	-0.2882	-0.2751
0.30	-0.5065	*****
0.40	-0.6580	-0.6238
0.50	-0.8231	*****
0.60	-0.6577	-0.8763
0.70	-0.9323	*****
0.80	-0.9778	-0.9119
0.90	*****	*****
0.95	-0.8595	-0.7364

Surface Pressures

● upper, starboard
 ○ lower, port

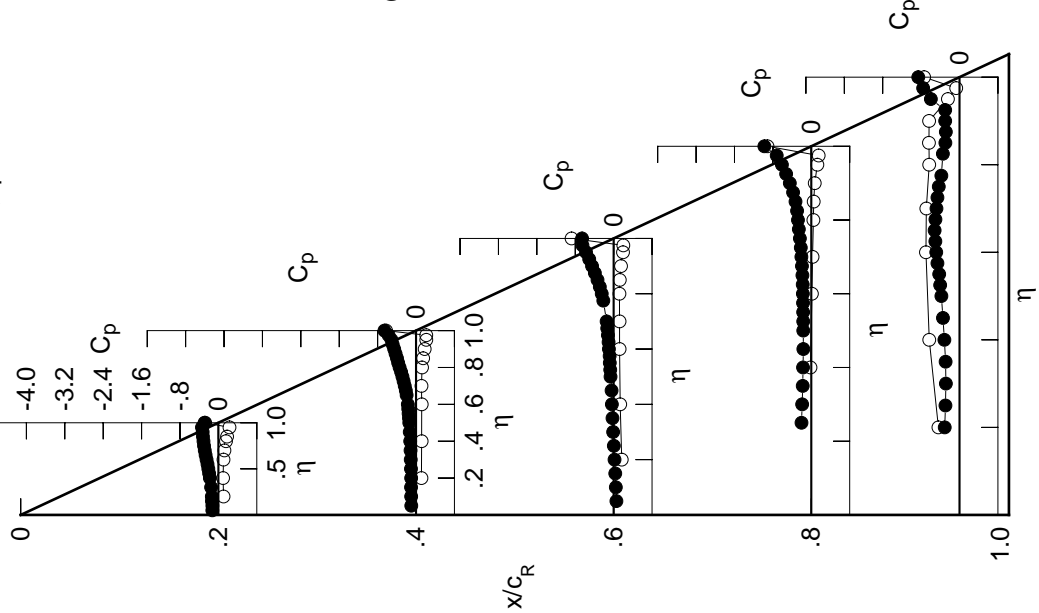

Table E2. Continued.

η	x/c_R .2	x/c_R .4	x/c_R .6	x/c_R .8	x/c_R .95
	$C_{p,u}$	$C_{p,u}$	$C_{p,u}$	$C_{p,u}$	$C_{p,u}$
0.050	-0.1471	-0.1171	0.0429	*****	*****
0.100	-0.1414	-0.1203	0.0337	*****	*****
0.150	-0.1529	-0.1220	0.0184	*****	*****
0.200	-0.1581	-0.1225	0.0059	*****	-0.3025
0.250	*****	-0.1257	-0.0125	-0.2216	-0.2827
0.300	-0.1741	-0.1311	-0.0256	-0.2077	-0.2676
0.350	*****	-0.1366	-0.0405	-0.1969	-0.2753
0.400	-0.2027	-0.1456	-0.0531	-0.1897	-0.2860
0.450	-0.2176	-0.1560	-0.0609	-0.1845	-0.3264
0.500	-0.2363	-0.1673	-0.0839	-0.1851	-0.4050
0.525	*****	-0.1743	-0.0900	-0.1843	-0.4766
0.550	-0.2566	-0.1839	-0.1018	-0.1867	-0.5364
0.575	*****	-0.1935	-0.1047	-0.1869	-0.6163
0.600	-0.2788	-0.2027	-0.1234	-0.1965	-0.6526
0.625	*****	*****	-0.1339	-0.2022	-0.6250
0.650	-0.3046	-0.2309	-0.1561	-0.2158	-0.5667
0.675	*****	-0.2486	-0.1762	-0.2386	-0.5056
0.700	-0.3261	-0.2723	-0.1979	-0.2694	-0.4762
0.725	*****	-0.2976	*****	-0.2894	-0.4576
0.750	-0.3480	-0.3259	*****	-0.2920	-0.4497
0.775	*****	-0.3557	-0.2667	-0.2967	-0.4738
0.800	-0.3652	-0.3919	-0.2939	-0.3157	*****
0.825	*****	-0.4293	-0.3295	-0.3349	-0.5811
0.850	-0.3844	-0.4611	-0.3781	-0.3838	-0.6015
0.875	*****	-0.5034	-0.4351	-0.4234	-0.7117
0.900	-0.4020	-0.5413	-0.5055	-0.5279	-0.7752
0.925	*****	-0.5911	-0.5773	-0.7023	-0.6914
0.950	-0.4400	-0.6344	-0.6757	-0.8335	-0.6721
0.975	*****	-0.7219	-0.8763	-0.8501	-0.7224
1.000	-0.4699	-0.9082	-0.8057	-1.1275	-0.9675
	$C_{p,l}$	$C_{p,l}$	$C_{p,l}$	$C_{p,l}$	$C_{p,l}$
-0.200	0.1290	0.1328	0.1852	*****	-0.4665
-0.400	0.1233	0.1378	0.1519	-0.0014	-0.6509
-0.600	0.1355	0.1395	0.1437	0.0280	-0.6899
-0.700	0.1545	0.1395	0.1420	0.0448	-0.6766
-0.800	0.1874	0.1538	0.1448	0.0644	-0.6140
-0.850	0.2066	0.1771	0.1551	0.0740	-0.6153
-0.900	*****	0.2059	0.1790	0.0976	-0.6037
-0.950	0.2384	0.2273	0.2108	0.1456	-0.2230
-0.975	*****	0.2037	0.1969	0.1572	-0.0546
-1.000	-0.4612	-0.8593	-1.0634	-1.0603	-0.7157

Medium Radius L.E.
 Run No. = 10, Point No. = 201
 $C_N = 0.311$, $C_m = -0.0602$
 $\alpha = 7.4^\circ$, $M_\infty = 0.850$
 $R_{mac} = 11.7 \times 10^6$

Leading Edge Pressures

● starboard
 ○ port

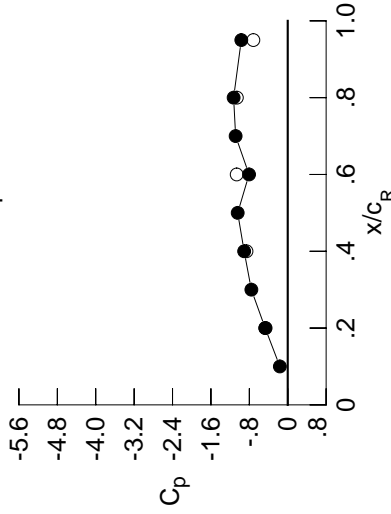

x/c_R	starb'd C_p	port C_p
0.10	-0.1636	*****
0.20	-0.4699	-0.4612
0.30	-0.7579	*****
0.40	-0.9082	-0.8593
0.50	-1.0424	*****
0.60	-0.8057	-1.0634
0.70	-1.0853	*****
0.80	-1.1275	-1.0603
0.90	*****	*****
0.95	-0.9675	-0.7157

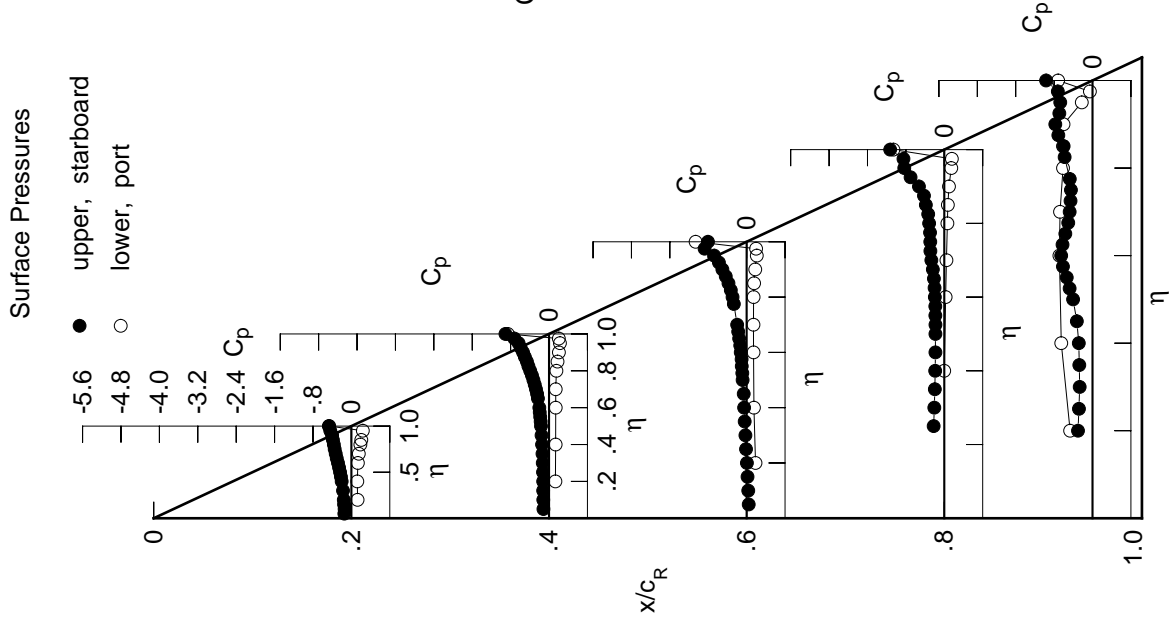
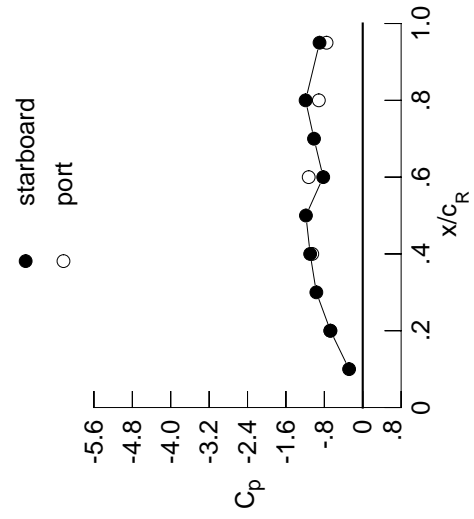

Table E2. Continued.

η	$x/c_R = .2$		$x/c_R = .4$		$x/c_R = .6$		$x/c_R = .8$		$x/c_R = .95$	
	$C_{p,u}$	$C_{p,u}$	$C_{p,u}$	$C_{p,u}$	$C_{p,u}$	$C_{p,u}$	$C_{p,u}$	$C_{p,u}$	$C_{p,u}$	$C_{p,u}$
0.050	-0.1624	-0.1357	0.0289	*****	*****	*****	*****	*****	*****	
0.100	-0.1583	-0.1386	0.0163	*****	*****	*****	*****	*****	*****	
0.150	-0.1721	-0.1416	0.0024	*****	*****	*****	*****	*****	*****	
0.200	-0.1769	-0.1404	-0.0111	*****	*****	*****	*****	-0.3091	*****	
0.250	*****	-0.1465	-0.0279	-0.2437	-0.2748	*****	*****	*****	*****	
0.300	-0.1938	-0.1521	-0.0434	-0.2288	-0.2404	*****	*****	*****	*****	
0.350	*****	-0.1587	-0.0569	-0.2180	-0.2505	*****	*****	*****	*****	
0.400	-0.2245	-0.1679	-0.0691	-0.2084	-0.2959	*****	*****	*****	*****	
0.450	-0.2420	-0.1813	-0.0761	-0.2016	-0.3508	*****	*****	*****	*****	
0.500	-0.2629	-0.1946	-0.1013	-0.2023	-0.3806	*****	*****	*****	*****	
0.525	*****	-0.2041	-0.1119	-0.2159	-0.3498	*****	*****	*****	*****	
0.550	-0.2852	-0.2168	-0.1258	-0.2355	-0.3145	*****	*****	*****	*****	
0.575	*****	-0.2293	-0.1369	-0.2552	-0.3406	*****	*****	*****	*****	
0.600	-0.3121	-0.2423	-0.1702	-0.2450	-0.3744	*****	*****	*****	*****	
0.625	*****	*****	-0.1889	-0.2313	-0.4149	*****	*****	*****	*****	
0.650	-0.3412	-0.2739	-0.2165	-0.2272	-0.4348	*****	*****	*****	*****	
0.675	*****	-0.2924	-0.2345	-0.2285	-0.4403	*****	*****	*****	*****	
0.700	-0.3685	-0.3142	-0.2371	-0.2420	-0.4598	*****	*****	*****	*****	
0.725	*****	-0.3393	*****	-0.2856	-0.4743	*****	*****	*****	*****	
0.750	-0.3953	-0.3664	*****	-0.3280	-0.4732	*****	*****	*****	*****	
0.775	*****	-0.3993	-0.2641	-0.3455	-0.4926	*****	*****	*****	*****	
0.800	-0.4223	-0.4375	-0.2843	-0.3854	*****	*****	*****	*****	*****	
0.825	*****	-0.4807	-0.3099	-0.4683	-0.5090	*****	*****	*****	*****	
0.850	-0.4517	-0.5216	-0.4120	-0.5995	-0.5036	*****	*****	*****	*****	
0.875	*****	-0.5703	-0.7000	-0.5959	-0.5870	*****	*****	*****	*****	
0.900	-0.4827	-0.6204	-0.9037	-0.6281	-0.9038	*****	*****	*****	*****	
0.925	*****	-0.6765	-0.9612	-0.7862	-0.9765	*****	*****	*****	*****	
0.950	-0.5430	-0.7392	-0.9558	-0.8824	-0.7863	*****	*****	*****	*****	
0.975	*****	-1.0044	-0.9317	-0.7678	-0.7807	*****	*****	*****	*****	
1.000	-0.6725	-1.0949	-0.8236	-1.1907	-0.9001	*****	*****	*****	*****	
-0.200	$C_{p,l}$	$C_{p,l}$	$C_{p,l}$	$C_{p,l}$	$C_{p,l}$	$C_{p,l}$	$C_{p,l}$	$C_{p,l}$	$C_{p,l}$	
-0.400	0.1550	0.1553	0.2036	*****	-0.4801	*****	*****	*****	*****	
-0.600	0.1508	0.1618	0.1715	0.0148	-0.6610	*****	*****	*****	*****	
-0.700	0.1651	0.1659	0.1643	0.0463	-0.6837	*****	*****	*****	*****	
-0.800	0.1851	0.1679	0.1663	0.0617	-0.6640	*****	*****	*****	*****	
-0.850	0.2159	0.1842	0.1710	0.0845	-0.5970	*****	*****	*****	*****	
-0.900	0.2321	0.2061	0.1822	0.0951	-0.5990	*****	*****	*****	*****	
-0.950	0.2431	0.2377	0.2260	0.1607	-0.2168	*****	*****	*****	*****	
-0.975	*****	0.1926	0.1973	0.1614	-0.0597	*****	*****	*****	*****	
-1.000	-0.6762	-1.0511	-1.1259	-0.9144	-0.7536	*****	*****	*****	*****	

Medium Radius L.E.
 Run No. = 10 , Point No. = 202
 $C_N = 0.369$, $C_m = -0.0718$
 $\alpha = 8.4^\circ$, $M_\infty = 0.849$
 $R_{mac} = 11.7 \times 10^6$

Leading Edge Pressures



x/c_R	starb'd C_p	port C_p
0.10	-0.2843	*****
0.20	-0.6725	-0.6762
0.30	-0.9668	*****
0.40	-1.0949	-1.0511
0.50	-1.1834	*****
0.60	-0.8236	-1.1259
0.70	-1.0153	*****
0.80	-1.1907	-0.9144
0.90	*****	*****
0.95	-0.9001	-0.7536

Surface Pressures

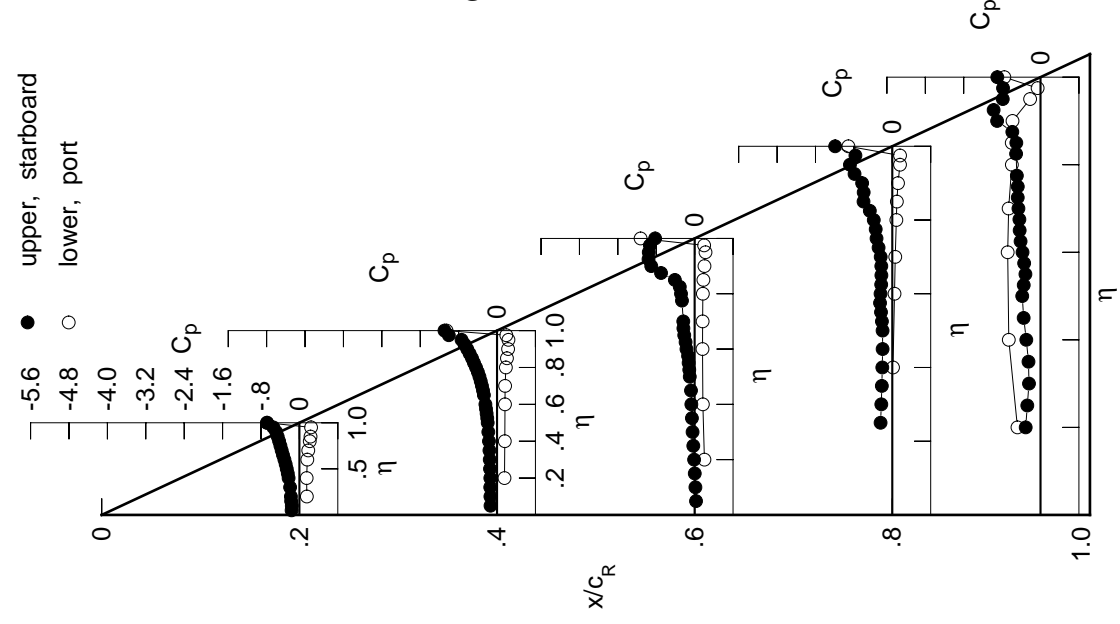
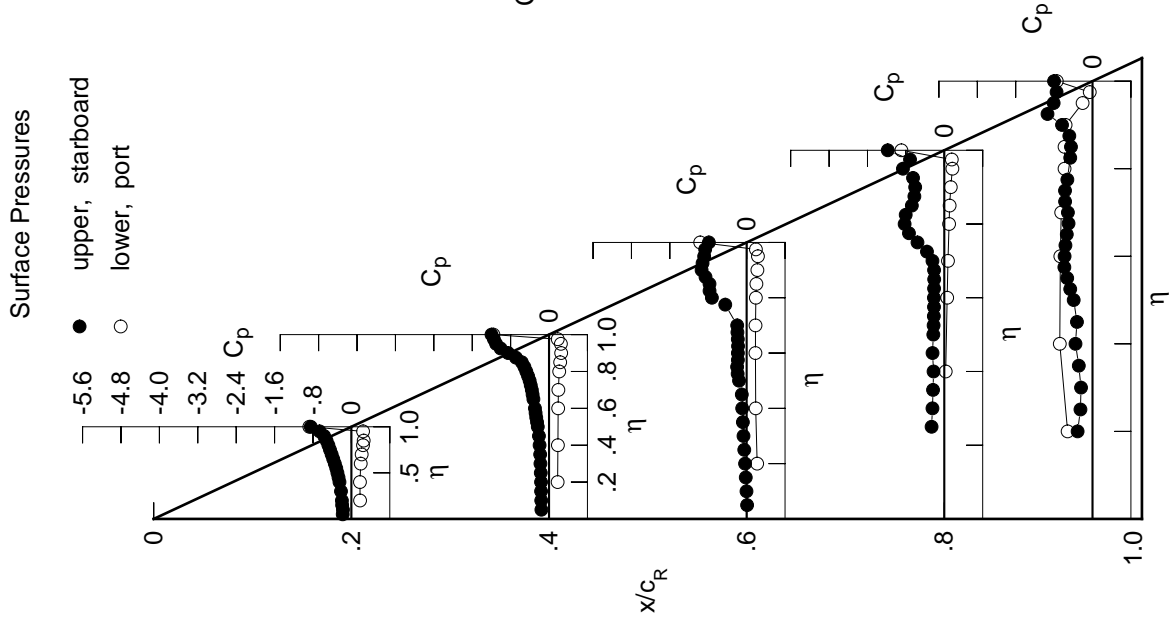
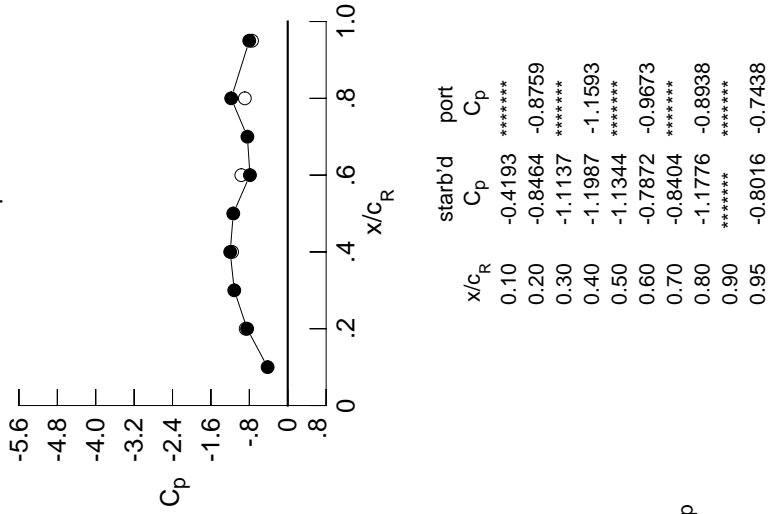

Table E2. Continued.

η	$x/c_R = .2$		$x/c_R = .4$		$x/c_R = .6$		$x/c_R = .8$		$x/c_R = .95$	
	$C_{p,u}$	$C_{p,u}$	$C_{p,u}$	$C_{p,u}$	$C_{p,u}$	$C_{p,u}$	$C_{p,u}$	$C_{p,u}$	$C_{p,u}$	$C_{p,u}$
0.050	-0.1809	-0.1594	0.0096	0.0096	0.0096	0.0096	0.0096	0.0096	0.0096	0.0096
0.100	-0.1761	-0.1623	-0.0036	-0.0036	-0.0036	-0.0036	-0.0036	-0.0036	-0.0036	-0.0036
0.150	-0.1927	-0.1658	-0.0180	-0.0180	-0.0180	-0.0180	-0.0180	-0.0180	-0.0180	-0.0180
0.200	-0.1979	-0.1666	-0.0324	-0.0324	-0.0324	-0.0324	-0.0324	-0.0324	-0.0324	-0.0324
0.250	*****	-0.1720	-0.0497	-0.0497	-0.0497	-0.0497	-0.0497	-0.0497	-0.0497	-0.0497
0.300	-0.2164	-0.1788	-0.0658	-0.0658	-0.0658	-0.0658	-0.0658	-0.0658	-0.0658	-0.0658
0.350	*****	-0.1851	-0.0781	-0.0781	-0.0781	-0.0781	-0.0781	-0.0781	-0.0781	-0.0781
0.400	-0.2476	-0.1970	-0.0931	-0.0931	-0.0931	-0.0931	-0.0931	-0.0931	-0.0931	-0.0931
0.450	-0.2678	-0.2103	-0.1011	-0.1011	-0.1011	-0.1011	-0.1011	-0.1011	-0.1011	-0.1011
0.500	-0.2908	-0.2347	-0.1588	-0.1588	-0.1588	-0.1588	-0.1588	-0.1588	-0.1588	-0.1588
0.525	*****	-0.2495	-0.1869	-0.1869	-0.1869	-0.1869	-0.1869	-0.1869	-0.1869	-0.1869
0.550	-0.3152	-0.2668	-0.1988	-0.1988	-0.1988	-0.1988	-0.1988	-0.1988	-0.1988	-0.1988
0.575	*****	-0.2800	-0.1827	-0.1827	-0.1827	-0.1827	-0.1827	-0.1827	-0.1827	-0.1827
0.600	-0.3457	-0.2934	-0.1823	-0.1823	-0.1823	-0.1823	-0.1823	-0.1823	-0.1823	-0.1823
0.625	*****	*****	-0.1794	-0.1794	-0.1794	-0.1794	-0.1794	-0.1794	-0.1794	-0.1794
0.650	-0.3784	-0.3258	-0.1841	-0.1841	-0.1841	-0.1841	-0.1841	-0.1841	-0.1841	-0.1841
0.675	*****	-0.3424	-0.1920	-0.1920	-0.1920	-0.1920	-0.1920	-0.1920	-0.1920	-0.1920
0.700	-0.4112	-0.3584	-0.1965	-0.1965	-0.1965	-0.1965	-0.1965	-0.1965	-0.1965	-0.1965
0.725	*****	-0.3808	*****	*****	-0.3605	-0.3605	-0.3605	-0.3605	-0.3605	-0.3605
0.750	-0.4455	-0.4036	*****	*****	-0.5586	-0.5586	-0.5586	-0.5586	-0.5586	-0.5586
0.775	*****	-0.4365	-0.4458	-0.4458	-0.7358	-0.7358	-0.7358	-0.7358	-0.7358	-0.7358
0.800	-0.4789	-0.4736	-0.7243	-0.7243	-0.8262	-0.8262	-0.8262	-0.8262	-0.8262	-0.8262
0.825	*****	-0.5134	-0.7731	-0.7731	-0.8041	-0.8041	-0.8041	-0.8041	-0.8041	-0.8041
0.850	-0.5173	-0.5676	-0.7739	-0.7739	-0.6761	-0.6761	-0.6761	-0.6761	-0.6761	-0.6761
0.875	*****	-0.6893	-0.8572	-0.8572	-0.6234	-0.6234	-0.6234	-0.6234	-0.6234	-0.6234
0.900	-0.5682	-0.8526	-0.9383	-0.9383	-0.6062	-0.6062	-0.6062	-0.6062	-0.6062	-0.6062
0.925	*****	-1.0085	-0.9182	-0.9182	-0.6509	-0.6509	-0.6509	-0.6509	-0.6509	-0.6509
0.950	-0.6614	-1.1021	-0.8844	-0.8844	-0.8619	-0.8619	-0.8619	-0.8619	-0.8619	-0.8619
0.975	*****	-1.1486	-0.8640	-0.8640	-0.7133	-0.7133	-0.7133	-0.7133	-0.7133	-0.7133
1.000	-0.8464	-1.1987	-0.7872	-0.7872	-1.1776	-1.1776	-1.1776	-1.1776	-1.1776	-1.1776

Medium Radius L.E.
 Run No. = 10 , Point No. = 203
 $C_N = 0.423$, $C_m = -0.0799$
 $\alpha = 9.5^\circ$, $M_\infty = 0.850$
 $R_{mac} = 11.7 \times 10^6$

Leading Edge Pressures
 ● starboard
 ○ port



x/c_R	starb'd C_p	port C_p
0.10	-0.4193	*****
0.20	-0.8464	-0.8759
0.30	-1.1137	*****
0.40	-1.1987	-1.1593
0.50	-1.1344	*****
0.60	-0.7872	-0.9673
0.70	-0.8404	*****
0.80	-1.1776	-0.8938
0.90	*****	*****
0.95	-0.8016	-0.7438

Table E2. Continued.

η	$x/c_R = 0.2$		$x/c_R = 0.4$		$x/c_R = 0.6$		$x/c_R = 0.8$		$x/c_R = 0.95$	
	$C_{p,u}$	$C_{p,u}$	$C_{p,u}$	$C_{p,u}$	$C_{p,u}$	$C_{p,u}$	$C_{p,u}$	$C_{p,u}$	$C_{p,u}$	$C_{p,u}$
0.050	-0.1978	-0.1843	-0.0122	*****	*****	*****	*****	*****	*****	*****
0.100	-0.1933	-0.1872	-0.0270	*****	*****	*****	*****	*****	*****	*****
0.150	-0.2127	-0.1919	-0.0403	*****	*****	*****	*****	*****	*****	*****
0.200	-0.2202	-0.1912	-0.0573	*****	*****	*****	*****	*****	*****	-0.2671
0.250	*****	-0.1979	-0.0721	-0.2860	-0.2860	-0.2309	*****	*****	*****	-0.2309
0.300	-0.2410	-0.2036	-0.0860	-0.2673	-0.2943	*****	*****	*****	*****	-0.2943
0.350	*****	-0.2080	-0.1041	-0.2658	-0.3385	*****	*****	*****	*****	-0.3385
0.400	-0.2740	-0.2212	-0.1478	-0.2613	-0.3566	*****	*****	*****	*****	-0.3566
0.450	-0.2951	-0.2591	-0.1548	-0.2455	-0.4310	*****	*****	*****	*****	-0.4310
0.500	-0.3199	-0.2954	-0.1579	-0.2439	-0.5089	*****	*****	*****	*****	-0.5089
0.525	*****	-0.3052	-0.1610	-0.2450	-0.5410	*****	*****	*****	*****	-0.5410
0.550	-0.3466	-0.3073	-0.1679	-0.2411	-0.5373	*****	*****	*****	*****	-0.5373
0.575	*****	-0.3017	-0.1697	-0.2475	-0.5600	*****	*****	*****	*****	-0.5600
0.600	-0.3796	-0.3017	-0.1920	-0.2675	-0.5553	*****	*****	*****	*****	-0.5553
0.625	*****	*****	-0.1958	-0.2921	-0.5576	*****	*****	*****	*****	-0.5576
0.650	-0.4166	-0.3129	-0.2158	-0.3333	-0.5727	*****	*****	*****	*****	-0.5727
0.675	*****	-0.3273	-0.2355	-0.4068	-0.5903	*****	*****	*****	*****	-0.5903
0.700	-0.4547	-0.3422	-0.2831	-0.4964	-0.6340	*****	*****	*****	*****	-0.6340
0.725	*****	-0.3548	*****	-0.6044	-0.6704	*****	*****	*****	*****	-0.6704
0.750	-0.4948	-0.3535	*****	-0.7092	-0.6521	*****	*****	*****	*****	-0.6521
0.775	*****	-0.4176	-0.7373	-0.8029	-0.6679	*****	*****	*****	*****	-0.6679
0.800	-0.5417	-0.7213	-0.7621	-0.8452	*****	*****	*****	*****	*****	-0.8452
0.825	*****	-0.9668	-0.7729	-0.8298	-0.4654	*****	*****	*****	*****	-0.4654
0.850	-0.5948	-1.0733	-0.7582	-0.7547	-0.4379	*****	*****	*****	*****	-0.4379
0.875	*****	-1.1130	-0.7940	-0.7066	-0.4538	*****	*****	*****	*****	-0.4538
0.900	-0.6521	-1.1135	-0.9112	-0.6826	-0.5540	*****	*****	*****	*****	-0.5540
0.925	*****	-1.0930	-0.9828	-0.6966	-0.7619	*****	*****	*****	*****	-0.7619
0.950	-0.7520	-1.0665	-0.9330	-0.8163	-0.6352	*****	*****	*****	*****	-0.6352
0.975	*****	-1.0495	-0.8942	-0.6795	-0.5453	*****	*****	*****	*****	-0.5453
1.000	-0.9831	-1.1666	-0.7995	-1.1050	-0.5992	*****	*****	*****	*****	-0.5992
-0.200	$C_{p,l}$	$C_{p,l}$	$C_{p,l}$	$C_{p,l}$	$C_{p,l}$	$C_{p,l}$	$C_{p,l}$	$C_{p,l}$	$C_{p,l}$	$C_{p,l}$
-0.400	0.2092	0.2035	0.2376	*****	*****	*****	*****	*****	*****	-0.5632
-0.600	0.2078	0.2103	0.2097	0.0434	-0.6791	*****	*****	*****	*****	-0.6791
-0.700	0.2254	0.2170	0.2020	0.0764	-0.6637	*****	*****	*****	*****	-0.6637
-0.800	0.2455	0.2218	0.2068	0.0920	-0.6426	*****	*****	*****	*****	-0.6426
-0.850	0.2696	0.2392	0.2135	0.1167	-0.5733	*****	*****	*****	*****	-0.5733
-0.900	0.2785	0.2582	0.2244	0.1283	-0.5713	*****	*****	*****	*****	-0.5713
-0.950	0.2424	0.2525	0.2418	0.1516	-0.5438	*****	*****	*****	*****	-0.5438
-0.975	*****	0.1720	0.1860	0.1519	-0.0500	*****	*****	*****	*****	-0.0500
-1.000	-1.0261	-1.1850	-0.8853	-0.8236	-0.5776	*****	*****	*****	*****	-0.5776

Medium Radius L.E.
 Run No. = 10 , Point No. = 204
 $C_N = 0.478$, $C_m = -0.0871$
 $\alpha = 10.5^\circ$, $M_\infty = 0.849$
 $R_{mac} = 11.7 \times 10^6$

Leading Edge Pressures

● starboard
 ○ port

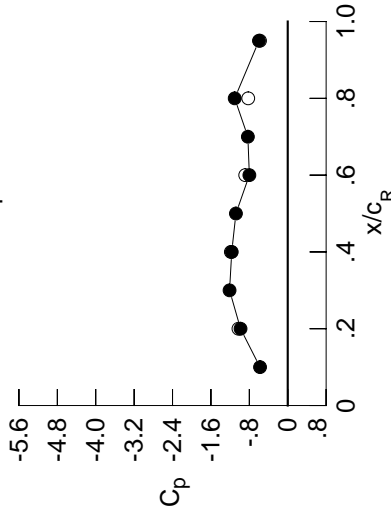

x/c_R	starb'd C_p	port C_p
0.10	-0.5771	*****
0.20	-0.9831	-1.0261
0.30	-1.2118	*****
0.40	-1.1666	-1.1850
0.50	-1.0792	*****
0.60	-0.7995	-0.8853
0.70	-0.8305	*****
0.80	-1.1050	-0.8236
0.90	*****	*****
0.95	-0.5992	-0.5776

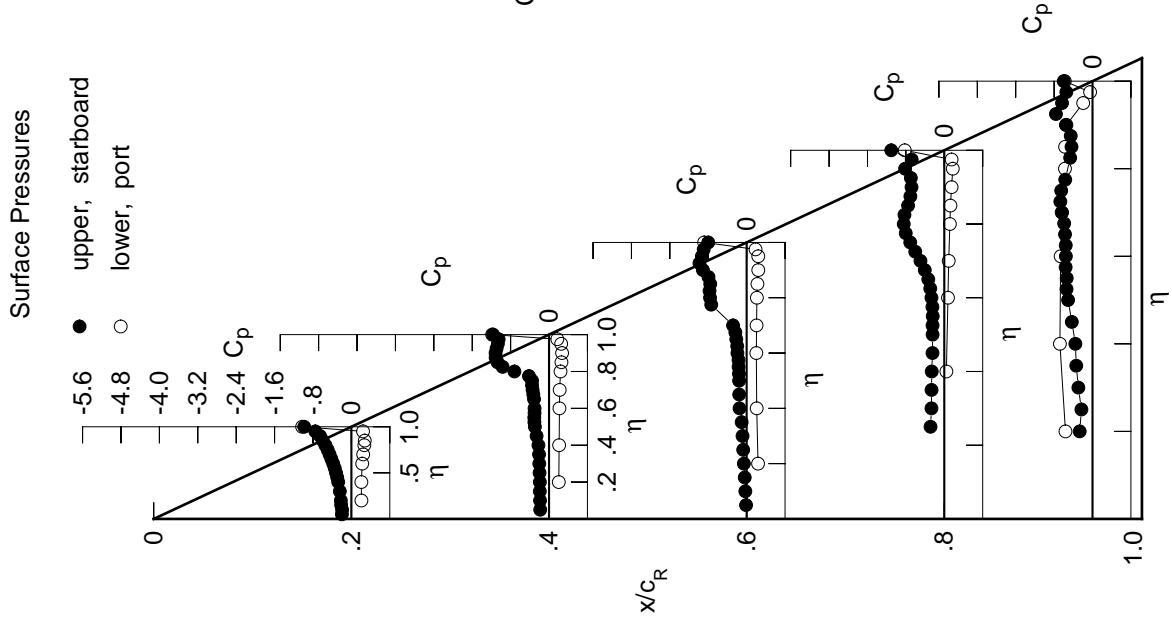
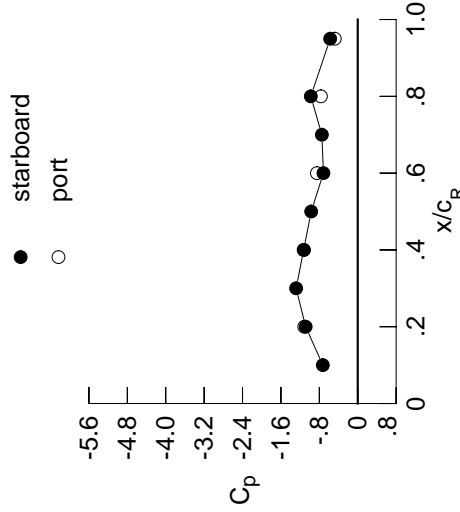

Table E2. Continued.

η	$x/c_R = 0.2$		$x/c_R = 0.4$		$x/c_R = 0.6$		$x/c_R = 0.8$		$x/c_R = 0.95$	
	$C_{p,u}$	$C_{p,u}$	$C_{p,u}$	$C_{p,u}$	$C_{p,u}$	$C_{p,u}$	$C_{p,u}$	$C_{p,u}$	$C_{p,u}$	$C_{p,u}$
0.050	-0.2164	-0.2136	-0.0364	*****	*****	*****	*****	*****	*****	*****
0.100	-0.2107	-0.2164	-0.0496	*****	*****	*****	*****	*****	*****	*****
0.150	-0.2358	-0.2209	-0.0669	*****	*****	*****	*****	*****	*****	*****
0.200	-0.2443	-0.2225	-0.0784	*****	*****	*****	*****	*****	*****	*****
0.250	*****	-0.2250	-0.0963	-0.3088	-0.3088	-0.3088	-0.3036	-0.3036	-0.3159	-0.3159
0.300	-0.2670	-0.2311	-0.1157	-0.3004	-0.3004	-0.2978	-0.2978	-0.2978	-0.2978	-0.2978
0.350	*****	-0.2378	-0.1606	-0.2968	-0.2968	-0.2261	-0.2261	-0.2261	-0.2261	-0.2261
0.400	-0.3036	-0.2728	-0.1631	-0.2703	-0.2703	-0.2753	-0.2753	-0.2753	-0.2753	-0.2753
0.450	-0.3257	-0.3150	-0.1552	-0.2592	-0.2592	-0.3751	-0.3751	-0.3751	-0.3751	-0.3751
0.500	-0.3521	-0.3302	-0.1691	-0.2507	-0.2507	-0.5173	-0.5173	-0.5173	-0.5173	-0.5173
0.525	*****	-0.3252	-0.1737	-0.2457	-0.2457	-0.5830	-0.5830	-0.5830	-0.5830	-0.5830
0.550	-0.3803	-0.3236	-0.1784	-0.2391	-0.2391	-0.5918	-0.5918	-0.5918	-0.5918	-0.5918
0.575	-0.4154	-0.3115	-0.1812	-0.2346	-0.2346	-0.6026	-0.6026	-0.6026	-0.6026	-0.6026
0.600	-0.4154	-0.3115	-0.1812	-0.2427	-0.2427	-0.5957	-0.5957	-0.5957	-0.5957	-0.5957
0.625	*****	*****	-0.1759	-0.2717	-0.2717	-0.6220	-0.6220	-0.6220	-0.6220	-0.6220
0.650	-0.4555	-0.3220	-0.2006	-0.3630	-0.3630	-0.7004	-0.7004	-0.7004	-0.7004	-0.7004
0.675	*****	-0.3323	-0.2889	-0.5594	-0.5594	-0.8065	-0.8065	-0.8065	-0.8065	-0.8065
0.700	-0.4966	-0.3274	-0.5304	-0.8128	-0.8128	-0.9033	-0.9033	-0.9033	-0.9033	-0.9033
0.725	*****	-0.2893	*****	-1.0305	-0.6462	-0.6462	-0.6462	-0.6462	-0.6462	-0.6462
0.750	-0.5486	-0.4025	*****	-1.1539	-0.5454	-0.5454	-0.5454	-0.5454	-0.5454	-0.5454
0.775	*****	-1.0330	-1.1678	-1.1025	-0.4899	-0.4899	-0.4899	-0.4899	-0.4899	-0.4899
0.800	-0.5980	-1.2152	-1.1511	-0.8936	*****	*****	*****	*****	*****	*****
0.825	*****	-1.2367	-1.1305	-0.8131	-0.4609	-0.4609	-0.4609	-0.4609	-0.4609	-0.4609
0.850	-0.6568	-1.2102	-1.0421	-0.8009	-0.4512	-0.4512	-0.4512	-0.4512	-0.4512	-0.4512
0.875	*****	-1.1798	-0.9442	-0.8037	-0.4801	-0.4801	-0.4801	-0.4801	-0.4801	-0.4801
0.900	-0.7627	-1.1418	-0.8907	-0.7499	-0.5695	-0.5695	-0.5695	-0.5695	-0.5695	-0.5695
0.925	*****	-1.1062	-0.8397	-0.7137	-0.7598	-0.7598	-0.7598	-0.7598	-0.7598	-0.7598
0.950	-1.0763	-1.0776	-0.7980	-0.7237	-0.6597	-0.6597	-0.6597	-0.6597	-0.6597	-0.6597
0.975	*****	-1.0623	-0.7761	-0.6215	-0.5637	-0.5637	-0.5637	-0.5637	-0.5637	-0.5637
1.000	-1.0847	-1.1267	-0.7147	-0.9776	-0.5740	-0.5740	-0.5740	-0.5740	-0.5740	-0.5740
-0.200	$C_{p,l}$	$C_{p,l}$	$C_{p,l}$	$C_{p,l}$	$C_{p,l}$	$C_{p,l}$	$C_{p,l}$	$C_{p,l}$	$C_{p,l}$	$C_{p,l}$
-0.400	0.2385	0.2283	0.2574	*****	-0.5707	-0.5707	-0.5707	-0.5707	-0.5707	-0.5707
-0.600	0.2389	0.2354	0.2282	0.0599	-0.6760	-0.6760	-0.6760	-0.6760	-0.6760	-0.6760
-0.700	0.2568	0.2425	0.2231	0.0923	-0.6563	-0.6563	-0.6563	-0.6563	-0.6563	-0.6563
-0.800	0.2755	0.2484	0.2258	0.1091	-0.6328	-0.6328	-0.6328	-0.6328	-0.6328	-0.6328
-0.850	0.2964	0.2650	0.2347	0.1322	-0.5616	-0.5616	-0.5616	-0.5616	-0.5616	-0.5616
-0.900	0.3001	0.2816	0.2453	0.1454	-0.5563	-0.5563	-0.5563	-0.5563	-0.5563	-0.5563
-0.950	*****	0.2894	0.2585	0.1678	-0.5238	-0.5238	-0.5238	-0.5238	-0.5238	-0.5238
-0.975	0.2413	0.2560	0.2470	0.1844	-0.1835	-0.1835	-0.1835	-0.1835	-0.1835	-0.1835
-1.000	*****	0.1594	0.1760	0.1476	-0.0436	-0.0436	-0.0436	-0.0436	-0.0436	-0.0436
-1.000	-1.1134	-1.1204	-0.8500	-0.7674	-0.4776	-0.4776	-0.4776	-0.4776	-0.4776	-0.4776

Medium Radius L.E.
 Run No. = 10 , Point No. = 205
 $C_N = 0.540$, $C_m = -0.0973$
 $\alpha = 11.6^\circ$, $M_\infty = 0.850$
 $R_{mac} = 11.7 \times 10^6$

Leading Edge Pressures



x/c_R	starb'd C_p	port C_p
0.10	-0.7271	*****
0.20	-1.0847	-1.1134
0.30	-1.2836	*****
0.40	-1.1267	-1.1204
0.50	-0.9692	*****
0.60	-0.7147	-0.8500
0.70	-0.7470	*****
0.80	-0.9776	-0.7674
0.90	*****	*****
0.95	-0.5740	-0.4776

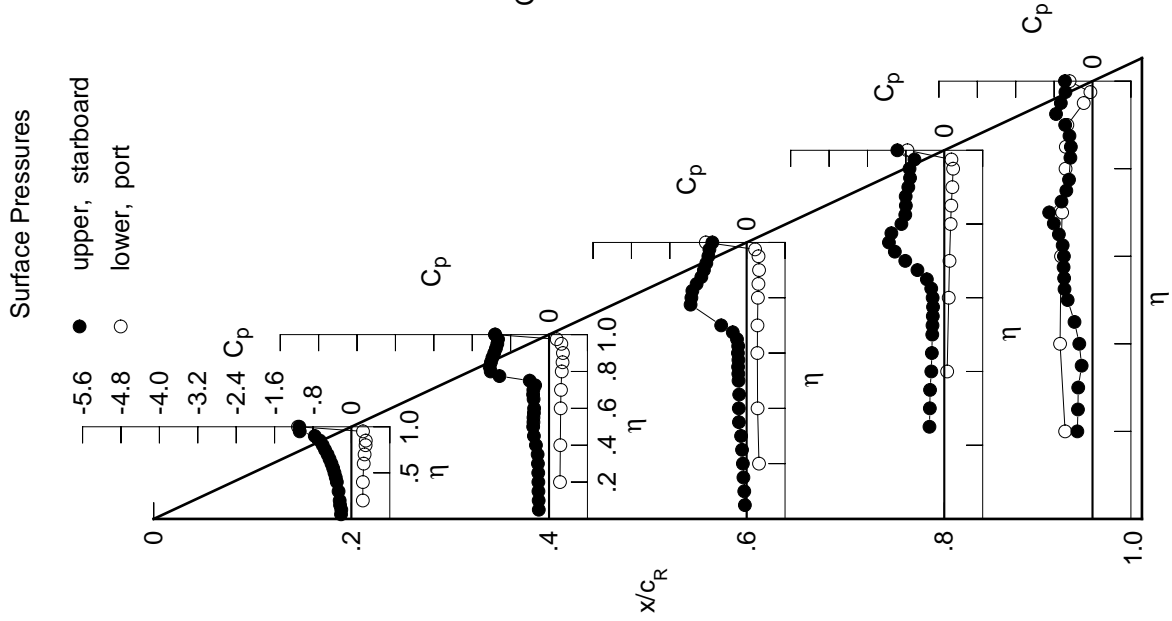

Table E2. Continued.

η	$x/c_R = .2$		$x/c_R = .4$		$x/c_R = .6$		$x/c_R = .8$		$x/c_R = .95$	
	$C_{p,u}$	$C_{p,l}$	$C_{p,u}$	$C_{p,l}$	$C_{p,u}$	$C_{p,l}$	$C_{p,u}$	$C_{p,l}$	$C_{p,u}$	$C_{p,l}$
0.050	-0.2384	-0.2478	-0.0542	*****	*****	*****	*****	*****	*****	*****
0.100	-0.2269	-0.2481	-0.0669	*****	*****	*****	*****	*****	*****	*****
0.150	-0.2601	-0.2539	-0.0844	*****	*****	*****	*****	*****	*****	*****
0.200	-0.2702	-0.2549	-0.0953	*****	*****	*****	*****	*****	*****	-0.4047
0.250	*****	-0.2550	-0.1143	-0.3066	-0.3066	-0.3066	-0.3925	-0.3925	-0.3925	-0.3925
0.300	-0.2989	-0.2627	-0.1435	-0.3000	-0.3000	-0.4282	-0.4282	-0.4282	-0.4282	-0.4282
0.350	*****	-0.2945	-0.1816	-0.2925	-0.2925	-0.4178	-0.4178	-0.4178	-0.4178	-0.4178
0.400	-0.3402	-0.3294	-0.1913	-0.2650	-0.2650	-0.4507	-0.4507	-0.4507	-0.4507	-0.4507
0.450	-0.3629	-0.3325	-0.1824	-0.2527	-0.2527	-0.5246	-0.5246	-0.5246	-0.5246	-0.5246
0.500	-0.3886	-0.3721	-0.1938	-0.2411	-0.2411	-0.5967	-0.5967	-0.5967	-0.5967	-0.5967
0.525	*****	-0.3708	-0.1958	-0.2386	-0.2386	-0.6177	-0.6177	-0.6177	-0.6177	-0.6177
0.550	-0.4158	-0.3706	-0.1992	-0.2380	-0.2380	-0.6110	-0.6110	-0.6110	-0.6110	-0.6110
0.575	*****	-0.3694	-0.1917	-0.2476	-0.2476	-0.6345	-0.6345	-0.6345	-0.6345	-0.6345
0.600	-0.4499	-0.3723	-0.2108	-0.2862	-0.2862	-0.6559	-0.6559	-0.6559	-0.6559	-0.6559
0.625	*****	*****	-0.2272	-0.3715	-0.3715	-0.7235	-0.7235	-0.7235	-0.7235	-0.7235
0.650	-0.4907	-0.3541	-0.3184	-0.5167	-0.5167	-0.8202	-0.8202	-0.8202	-0.8202	-0.8202
0.675	*****	-0.3562	-0.5292	-0.7534	-0.7534	-0.8785	-0.8785	-0.8785	-0.8785	-0.8785
0.700	-0.5344	-0.3511	-0.8412	-0.9872	-0.9872	-0.6336	-0.6336	-0.6336	-0.6336	-0.6336
0.725	*****	-0.3514	*****	-1.1824	-0.5828	-0.5828	-0.5828	-0.5828	-0.5828	-0.5828
0.750	-0.5727	-0.6678	*****	-1.0715	-0.5427	-0.5427	-0.5427	-0.5427	-0.5427	-0.5427
0.775	*****	-1.2536	-1.3036	-0.8499	-0.5090	-0.5090	-0.5090	-0.5090	-0.5090	-0.5090
0.800	-0.6375	-1.3948	-1.2444	-0.8308	*****	*****	*****	*****	*****	*****
0.825	*****	-1.3812	-1.1457	-0.8210	-0.4969	-0.4969	-0.4969	-0.4969	-0.4969	-0.4969
0.850	-0.9039	-1.3388	-1.0012	-0.8363	-0.4858	-0.4858	-0.4858	-0.4858	-0.4858	-0.4858
0.875	*****	-1.2780	-0.9547	-0.7956	-0.5047	-0.5047	-0.5047	-0.5047	-0.5047	-0.5047
0.900	-1.1104	-1.2036	-0.9265	-0.7409	-0.5486	-0.5486	-0.5486	-0.5486	-0.5486	-0.5486
0.925	*****	-1.1500	-0.8638	-0.7390	-0.5777	-0.5777	-0.5777	-0.5777	-0.5777	-0.5777
0.950	-1.2131	-1.1182	-0.8290	-0.7514	-0.4862	-0.4862	-0.4862	-0.4862	-0.4862	-0.4862
0.975	*****	-1.0959	-0.8072	-0.6474	-0.4251	-0.4251	-0.4251	-0.4251	-0.4251	-0.4251
1.000	-1.1691	-1.1283	-0.7351	-0.9408	-0.4802	-0.4802	-0.4802	-0.4802	-0.4802	-0.4802
-0.200	$C_{p,l}$	0.2518	0.2735	*****	*****	-0.5660	-0.5660	-0.5660	-0.5660	-0.5660
-0.400	0.2688	0.2595	0.2458	0.0744	-0.6716	-0.6716	-0.6716	-0.6716	-0.6716	-0.6716
-0.600	0.2879	0.2679	0.2399	0.1059	-0.6488	-0.6488	-0.6488	-0.6488	-0.6488	-0.6488
-0.700	0.3052	0.2732	0.2439	0.1239	-0.6255	-0.6255	-0.6255	-0.6255	-0.6255	-0.6255
-0.800	0.3218	0.2892	0.2526	0.1458	-0.5529	-0.5529	-0.5529	-0.5529	-0.5529	-0.5529
-0.850	0.3222	0.3023	0.2624	0.1587	-0.5446	-0.5446	-0.5446	-0.5446	-0.5446	-0.5446
-0.900	*****	0.3050	0.2716	0.1796	-0.5083	-0.5083	-0.5083	-0.5083	-0.5083	-0.5083
-0.950	0.2405	0.2592	0.2484	0.1867	-0.1762	-0.1762	-0.1762	-0.1762	-0.1762	-0.1762
-0.975	*****	0.1482	0.1637	0.1363	-0.0446	-0.0446	-0.0446	-0.0446	-0.0446	-0.0446
-1.000	-1.1697	-1.0568	-0.8407	-0.7942	-0.4554	-0.4554	-0.4554	-0.4554	-0.4554	-0.4554

Medium Radius L.E.

Run No. = 10 , Point No. = 206

$C_N = 0.594$, $C_m = -0.1044$

$\alpha = 12.6^\circ$, $M_\infty = 0.849$

$R_{mac} = 11.7 \times 10^6$

Leading Edge Pressures

● starboard
○ port

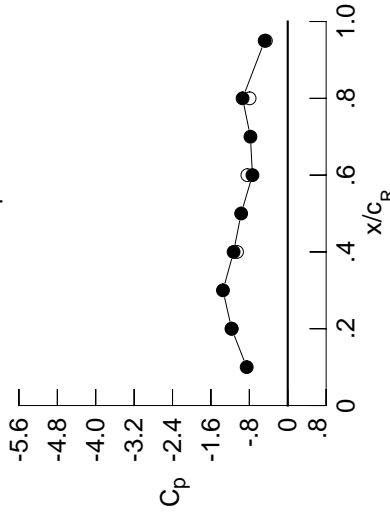

x/c_R	starb'd C_p	port C_p
0.10	-0.8548	*****
0.20	-1.1691	-1.1697
0.30	-1.3494	*****
0.40	-1.1283	-1.0568
0.50	-0.9705	*****
0.60	-0.7351	-0.8407
0.70	-0.7769	*****
0.80	-0.9408	-0.7942
0.90	*****	*****
0.95	-0.4802	-0.4554

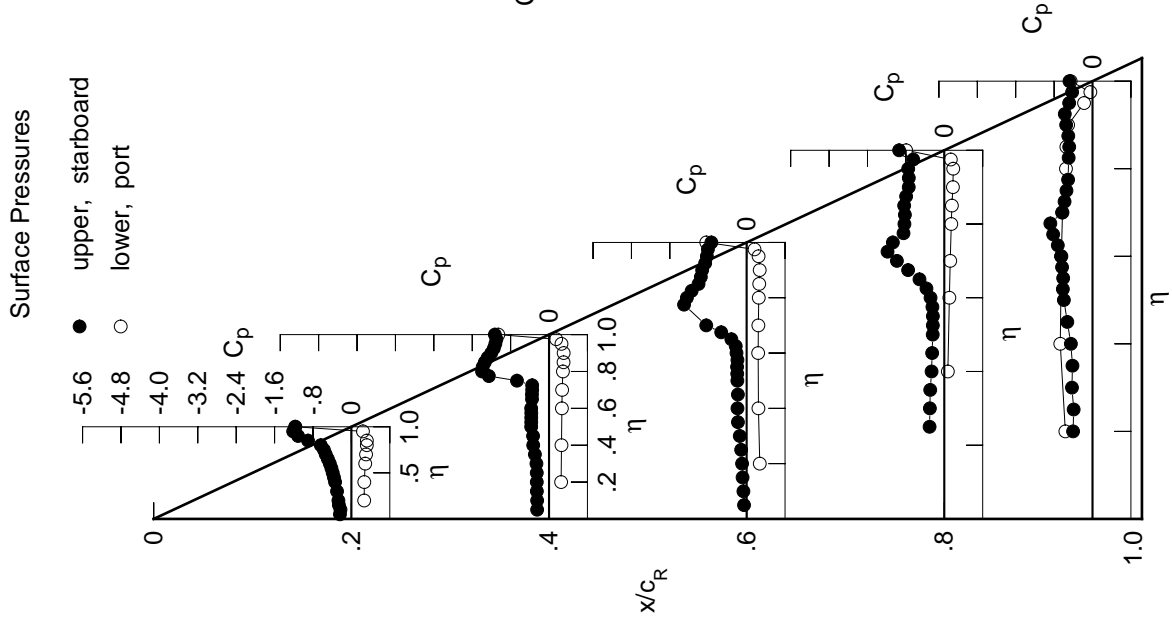

Table E2. Continued.

η	$x/c_R = .2$		$x/c_R = .4$		$x/c_R = .6$		$x/c_R = .8$		$x/c_R = .95$	
	$C_{p,u}$	$C_{p,u}$	$C_{p,u}$	$C_{p,u}$	$C_{p,u}$	$C_{p,u}$	$C_{p,u}$	$C_{p,u}$	$C_{p,u}$	$C_{p,u}$
0.050	-0.2588	-0.2875	-0.0762	*****	*****	*****	*****	*****	*****	*****
0.100	-0.2474	-0.2885	-0.0907	*****	*****	*****	*****	*****	*****	*****
0.150	-0.2795	-0.2916	-0.1021	*****	*****	*****	*****	*****	*****	*****
0.200	-0.2958	-0.2851	-0.1195	*****	*****	*****	*****	*****	*****	*****
0.250	*****	-0.3026	-0.1417	-0.3670	-0.3679	-0.3679	-0.3679	-0.3679	-0.3679	-0.3679
0.300	-0.3384	-0.3262	-0.1694	-0.3567	-0.4035	-0.4035	-0.4035	-0.4035	-0.4035	-0.4035
0.350	*****	-0.3505	-0.2026	-0.3534	-0.4109	-0.4109	-0.4109	-0.4109	-0.4109	-0.4109
0.400	-0.3706	-0.3520	-0.2285	-0.3412	-0.4235	-0.4235	-0.4235	-0.4235	-0.4235	-0.4235
0.450	-0.3981	-0.3755	-0.2214	-0.3295	-0.4506	-0.4506	-0.4506	-0.4506	-0.4506	-0.4506
0.500	-0.4144	-0.4232	-0.2394	-0.3254	-0.5293	-0.5293	-0.5293	-0.5293	-0.5293	-0.5293
0.525	*****	-0.4420	-0.2413	-0.3329	-0.5799	-0.5799	-0.5799	-0.5799	-0.5799	-0.5799
0.550	-0.4284	-0.4405	-0.2495	-0.3493	-0.6194	-0.6194	-0.6194	-0.6194	-0.6194	-0.6194
0.575	*****	-0.4293	-0.2609	-0.3962	-0.6956	-0.6956	-0.6956	-0.6956	-0.6956	-0.6956
0.600	-0.4665	-0.4333	-0.3328	-0.4823	-0.7833	-0.7833	-0.7833	-0.7833	-0.7833	-0.7833
0.625	*****	*****	-0.4239	-0.6274	-0.9132	-0.9132	-0.9132	-0.9132	-0.9132	-0.9132
0.650	-0.5057	-0.4385	-0.6456	-0.8197	-1.0518	-1.0518	-1.0518	-1.0518	-1.0518	-1.0518
0.675	*****	-0.4540	-0.9113	-1.0228	-0.8482	-0.8482	-0.8482	-0.8482	-0.8482	-0.8482
0.700	-0.6081	-0.5238	-1.1235	-1.1929	-0.7061	-0.7061	-0.7061	-0.7061	-0.7061	-0.7061
0.725	*****	-0.7777	*****	-1.2855	-0.6602	-0.6602	-0.6602	-0.6602	-0.6602	-0.6602
0.750	-0.7262	-1.1375	*****	-1.0764	-0.6060	-0.6060	-0.6060	-0.6060	-0.6060	-0.6060
0.775	*****	-1.3139	-1.2677	-0.9602	-0.5598	-0.5598	-0.5598	-0.5598	-0.5598	-0.5598
0.800	-0.6847	-1.3483	-1.1833	-0.9224	*****	*****	*****	*****	*****	*****
0.825	*****	-1.3393	-1.0807	-0.9118	-0.5141	-0.5141	-0.5141	-0.5141	-0.5141	-0.5141
0.850	-1.2096	-1.3176	-1.0028	-0.9072	-0.4870	-0.4870	-0.4870	-0.4870	-0.4870	-0.4870
0.875	*****	-1.2716	-0.9719	-0.8786	-0.4919	-0.4919	-0.4919	-0.4919	-0.4919	-0.4919
0.900	-1.2998	-1.2163	-0.9447	-0.8238	-0.5034	-0.5034	-0.5034	-0.5034	-0.5034	-0.5034
0.925	*****	-1.1729	-0.8980	-0.7883	-0.5136	-0.5136	-0.5136	-0.5136	-0.5136	-0.5136
0.950	-1.2959	-1.1431	-0.8606	-0.7851	-0.4371	-0.4371	-0.4371	-0.4371	-0.4371	-0.4371
0.975	*****	-1.1109	-0.8371	-0.7165	-0.3763	-0.3763	-0.3763	-0.3763	-0.3763	-0.3763
1.000	-1.2405	-1.1298	-0.7587	-0.9072	-0.3973	-0.3973	-0.3973	-0.3973	-0.3973	-0.3973
-0.200	$C_{p,l}$	$C_{p,l}$	$C_{p,l}$	$C_{p,l}$	$C_{p,l}$	$C_{p,l}$	$C_{p,l}$	$C_{p,l}$	$C_{p,l}$	$C_{p,l}$
-0.400	0.3005	0.2777	0.2932	*****	-0.5860	-0.5860	-0.5860	-0.5860	-0.5860	-0.5860
-0.600	0.3016	0.2858	0.2670	0.0889	-0.6600	-0.6600	-0.6600	-0.6600	-0.6600	-0.6600
-0.700	0.3202	0.2925	0.2595	0.1252	-0.6412	-0.6412	-0.6412	-0.6412	-0.6412	-0.6412
-0.800	0.3363	0.3000	0.2660	0.1379	-0.6135	-0.6135	-0.6135	-0.6135	-0.6135	-0.6135
-0.850	0.3479	0.3138	0.2733	0.1649	-0.5388	-0.5388	-0.5388	-0.5388	-0.5388	-0.5388
-0.900	0.3442	0.3245	0.2804	0.1764	-0.5280	-0.5280	-0.5280	-0.5280	-0.5280	-0.5280
-0.950	*****	0.3201	0.2854	0.1940	-0.4866	-0.4866	-0.4866	-0.4866	-0.4866	-0.4866
-0.975	0.2410	0.2616	0.2466	0.1901	-0.1642	-0.1642	-0.1642	-0.1642	-0.1642	-0.1642
-1.000	*****	0.1357	0.1470	0.1227	-0.0436	-0.0436	-0.0436	-0.0436	-0.0436	-0.0436
-1.000	-1.2111	-1.0233	-0.8754	-0.8373	-0.4217	-0.4217	-0.4217	-0.4217	-0.4217	-0.4217

Medium Radius L.E.
 Run No. = 10 , Point No. = 207
 $C_N = 0.654$, $C_m = -0.1134$
 $\alpha = 13.7^\circ$, $M_\infty = 0.850$
 $R_{mac} = 11.7 \times 10^6$

Leading Edge Pressures

● starboard
 ○ port

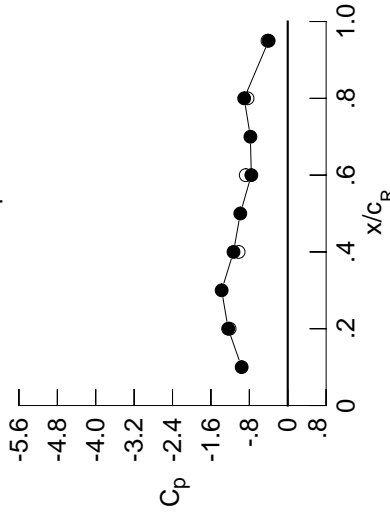

x/c_R	starb'd C_p	port C_p
0.10	-0.9603	*****
0.20	-1.2405	-1.2111
0.30	-1.3768	*****
0.40	-1.1298	-1.0233
0.50	-0.9882	*****
0.60	-0.7587	-0.8754
0.70	-0.7779	*****
0.80	-0.9072	-0.8373
0.90	*****	*****
0.95	-0.3973	-0.4217

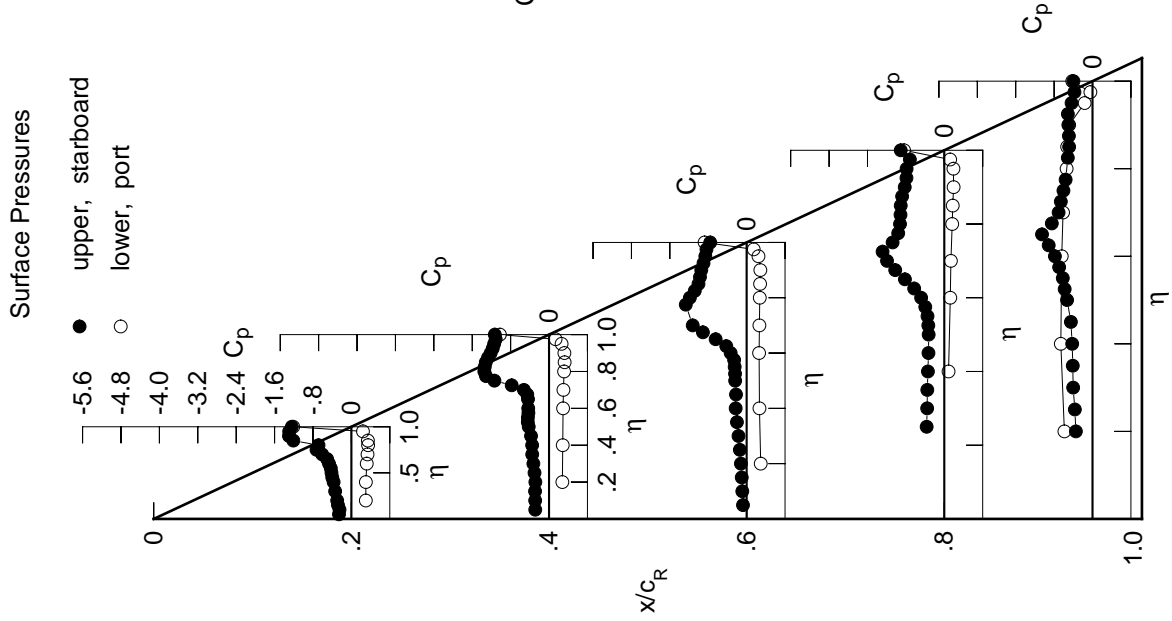

Table E2. Continued.

η	$x/c_R = 0.2$		$x/c_R = 0.4$		$x/c_R = 0.6$		$x/c_R = 0.8$		$x/c_R = 0.95$	
	$C_{p,u}$	$C_{p,u}$	$C_{p,u}$	$C_{p,u}$	$C_{p,u}$	$C_{p,u}$	$C_{p,u}$	$C_{p,u}$	$C_{p,u}$	$C_{p,u}$
0.050	-0.2864	-0.3314	-0.0983	*****	*****	*****	*****	*****	*****	*****
0.100	-0.2704	-0.3281	-0.1116	*****	*****	*****	*****	*****	*****	*****
0.150	-0.3052	-0.3301	-0.1227	*****	*****	*****	*****	*****	*****	*****
0.200	-0.3195	-0.3306	-0.1487	*****	*****	*****	*****	*****	*****	-0.4238
0.250	*****	-0.3653	-0.1696	-0.4068	-0.3390	*****	*****	*****	*****	*****
0.300	-0.3789	-0.3583	-0.1763	-0.3841	-0.2899	*****	*****	*****	*****	*****
0.350	*****	-0.3526	-0.1833	-0.3695	-0.3490	*****	*****	*****	*****	*****
0.400	-0.3912	-0.3543	-0.1921	-0.3534	-0.4889	*****	*****	*****	*****	*****
0.450	-0.4163	-0.3543	-0.1911	-0.3497	-0.6318	*****	*****	*****	*****	*****
0.500	-0.4494	-0.3536	-0.2330	-0.3634	-0.6884	*****	*****	*****	*****	*****
0.525	*****	-0.3688	-0.2737	-0.3964	-0.7201	*****	*****	*****	*****	*****
0.550	-0.4588	-0.4183	-0.3567	-0.4548	-0.7686	*****	*****	*****	*****	*****
0.575	*****	-0.4853	-0.4910	-0.5614	-0.8635	*****	*****	*****	*****	*****
0.600	-0.4742	-0.6123	-0.7304	-0.7110	-0.9705	*****	*****	*****	*****	*****
0.625	*****	*****	-0.9453	-0.8933	-1.1025	*****	*****	*****	*****	*****
0.650	-0.4604	-1.0264	-1.1514	-1.0781	-0.7550	*****	*****	*****	*****	*****
0.675	*****	-1.1813	-1.2888	-1.2399	-0.6715	*****	*****	*****	*****	*****
0.700	-0.7163	-1.2598	-1.3454	-1.2794	-0.6389	*****	*****	*****	*****	*****
0.725	*****	-1.2543	*****	-1.0636	-0.5977	*****	*****	*****	*****	*****
0.750	-1.0151	-1.2527	*****	-0.9879	-0.5548	*****	*****	*****	*****	*****
0.775	*****	-1.2518	-1.1934	-0.9708	-0.5192	*****	*****	*****	*****	*****
0.800	-1.1745	-1.2457	-1.0941	-0.9646	*****	*****	*****	*****	*****	*****
0.825	*****	-1.2142	-1.0316	-0.9781	-0.4863	*****	*****	*****	*****	*****
0.850	-1.3145	-1.1787	-0.9935	-0.9769	-0.4673	*****	*****	*****	*****	*****
0.875	*****	-1.1370	-0.9803	-0.9228	-0.4783	*****	*****	*****	*****	*****
0.900	-1.2996	-1.1056	-0.9385	-0.8375	-0.4777	*****	*****	*****	*****	*****
0.925	*****	-1.0763	-0.8794	-0.7993	-0.4625	*****	*****	*****	*****	*****
0.950	-1.2588	-1.0567	-0.8458	-0.8034	-0.4018	*****	*****	*****	*****	*****
0.975	*****	-1.0378	-0.8259	-0.7520	-0.3513	*****	*****	*****	*****	*****
1.000	-1.2892	-1.0514	-0.7586	-0.8869	-0.3668	*****	*****	*****	*****	*****
-0.200	$C_{p,l}$	$C_{p,l}$	$C_{p,l}$	$C_{p,l}$	$C_{p,l}$	$C_{p,l}$	$C_{p,l}$	$C_{p,l}$	$C_{p,l}$	$C_{p,l}$
-0.400	0.3253	0.3006	0.3061	*****	-0.5844	*****	*****	*****	*****	*****
-0.600	0.3303	0.3050	0.2821	0.1022	-0.6557	*****	*****	*****	*****	*****
-0.700	0.3478	0.3157	0.2740	0.1371	-0.6326	*****	*****	*****	*****	*****
-0.800	0.3625	0.3217	0.2811	0.1510	-0.6073	*****	*****	*****	*****	*****
-0.850	0.3682	0.3336	0.2884	0.1748	-0.5301	*****	*****	*****	*****	*****
-0.900	0.3603	0.3406	0.2939	0.1877	-0.5161	*****	*****	*****	*****	*****
-0.950	*****	0.3297	0.2937	0.2034	-0.4730	*****	*****	*****	*****	*****
-0.975	0.2353	0.2570	0.2425	0.1886	-0.1601	*****	*****	*****	*****	*****
-1.000	*****	0.1157	0.1265	0.1088	-0.0486	*****	*****	*****	*****	*****
	-1.2512	-1.0168	-0.9079	-0.8539	-0.4112	*****	*****	*****	*****	*****

Medium Radius L.E.
 Run No. = 10 , Point No. = 208
 $C_N = 0.711$, $C_m = -0.1211$
 $\alpha = 14.7^\circ$, $M_\infty = 0.849$
 $R_{mac} = 11.7 \times 10^6$

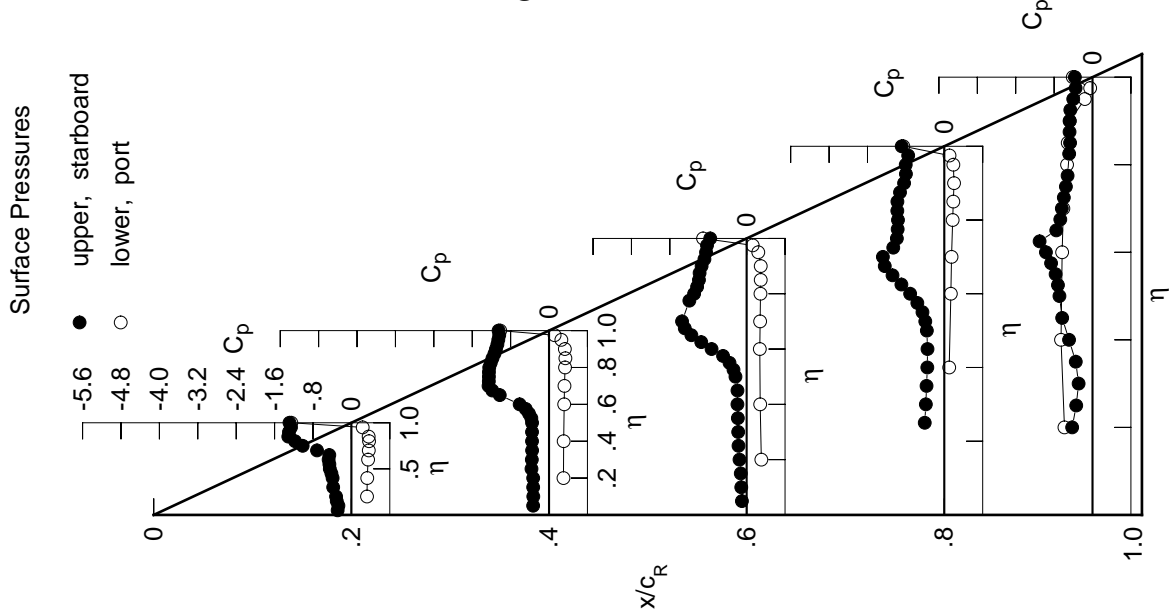
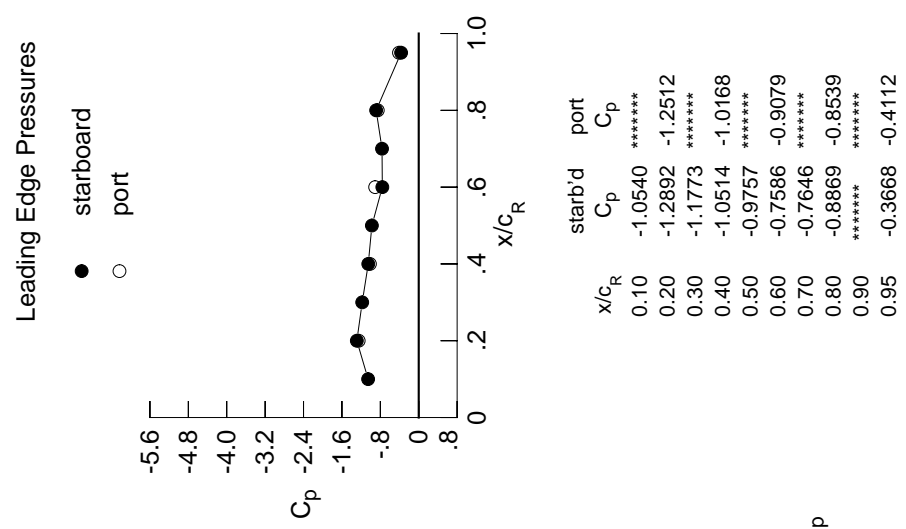

Table E2. Continued.

η	x/c_R .2	x/c_R .4	x/c_R .6	x/c_R .8	x/c_R .95
	$C_{p,u}$	$C_{p,u}$	$C_{p,u}$	$C_{p,u}$	$C_{p,u}$
0.050	-0.3427	-0.4093	-0.1293	*****	*****
0.100	-0.3268	-0.4049	-0.1425	*****	*****
0.150	-0.3497	-0.4025	-0.1570	*****	*****
0.200	-0.3956	-0.4247	-0.1848	*****	-0.5821
0.250	*****	-0.4128	-0.1928	-0.4600	-0.5137
0.300	-0.3988	-0.4095	-0.2070	-0.4419	-0.5148
0.350	*****	-0.4042	-0.2186	-0.4297	-0.5989
0.400	-0.4154	-0.3952	-0.2399	-0.4271	-0.6992
0.450	-0.4374	-0.3982	-0.2705	-0.4495	-0.7414
0.500	-0.4500	-0.4706	-0.4085	-0.5333	-0.8204
0.525	*****	-0.6037	-0.5336	-0.6163	-0.8782
0.550	-0.4247	-0.7908	-0.7080	-0.7277	-0.9621
0.575	*****	-0.9920	-0.9010	-0.8751	-1.0706
0.600	-0.4220	-1.1553	-1.1224	-1.0279	-0.9472
0.625	*****	*****	-1.2821	-1.1793	-0.6417
0.650	-1.1662	-1.4019	-1.4141	-1.2902	-0.5622
0.675	*****	-1.4771	-1.4898	-0.9688	-0.5026
0.700	-1.4468	-1.5128	-1.3372	-0.9349	-0.4799
0.725	*****	-1.4237	*****	-0.9290	-0.4731
0.750	-1.3285	-1.3285	*****	-0.9320	-0.4642
0.775	*****	-1.2981	-1.1829	-0.9522	-0.4572
0.800	-1.3877	-1.2526	-1.1504	-0.9896	*****
0.825	*****	-1.2112	-1.1274	-1.0005	-0.4436
0.850	-1.3427	-1.1902	-1.1136	-0.9698	-0.4301
0.875	*****	-1.1714	-1.0777	-0.9120	-0.4124
0.900	-1.2649	-1.1477	-0.9953	-0.8970	-0.3854
0.925	*****	-1.1184	-0.9413	-0.9237	-0.3659
0.950	-1.2409	-1.1043	-0.9221	-0.9428	-0.3390
0.975	*****	-1.0905	-0.9014	-0.9102	-0.3160
1.000	-1.2821	-1.0943	-0.8155	-0.9680	-0.3378
	$C_{p,l}$	$C_{p,l}$	$C_{p,l}$	$C_{p,l}$	$C_{p,l}$
-0.200	0.3853	0.3457	0.3433	*****	-0.5722
-0.400	0.3894	0.3519	0.3189	0.1328	-0.6372
-0.600	0.4052	0.3607	0.3115	0.1670	-0.6150
-0.700	0.4142	0.3665	0.3167	0.1796	-0.5866
-0.800	0.4101	0.3734	0.3212	0.2033	-0.5061
-0.850	0.3926	0.3726	0.3222	0.2134	-0.4898
-0.900	*****	0.3478	0.3110	0.2219	-0.4431
-0.950	0.2247	0.2488	0.2324	0.1862	-0.1483
-0.975	*****	0.0778	0.0873	0.0796	-0.0588
-1.000	-1.2943	-1.0645	-0.9796	-0.9032	-0.4078

Medium Radius L.E.

Run No. = 10, Point No. = 209

$C_N = 0.811$, $C_m = -0.1304$

$\alpha = 16.8^\circ$, $M_\infty = 0.849$

$R_{mac} = 11.7 \times 10^6$

Leading Edge Pressures

● starboard
○ port

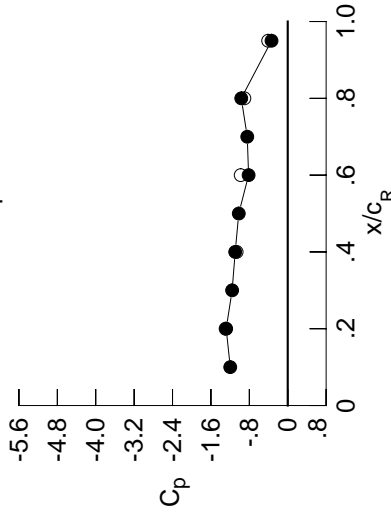

x/c_R	starb'd C_p	port C_p
0.10	-1.1972	*****
0.20	-1.2821	-1.2943
0.30	-1.1583	*****
0.40	-1.0943	-1.0645
0.50	-1.0202	*****
0.60	-0.8155	-0.9796
0.70	-0.8430	*****
0.80	-0.9680	-0.9032
0.90	*****	*****
0.95	-0.3378	-0.4078

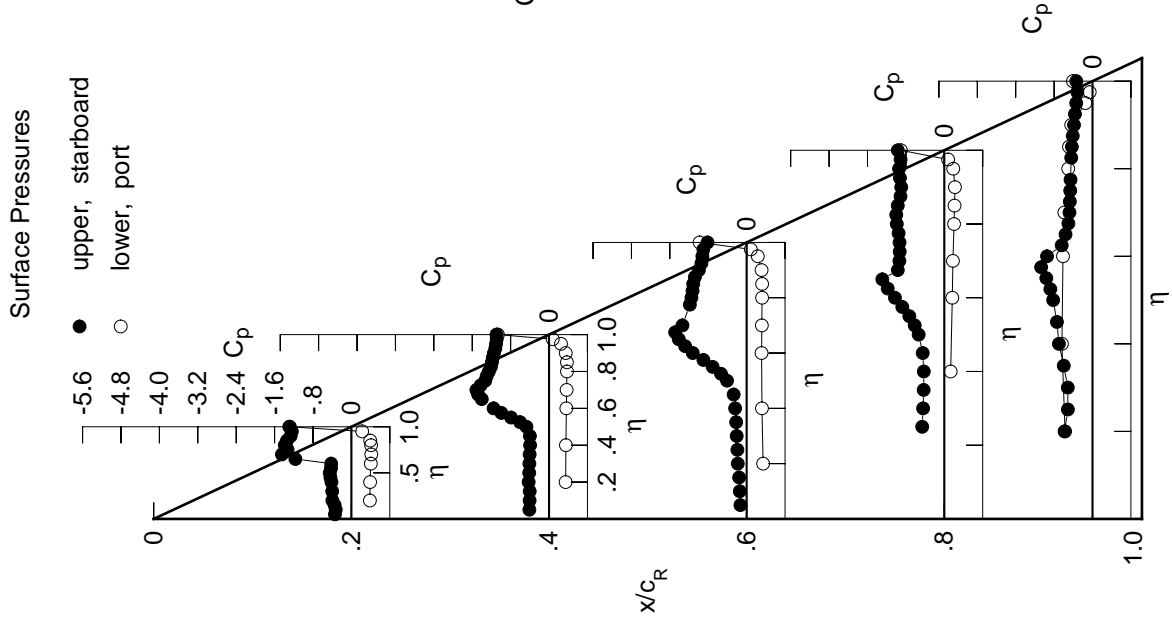
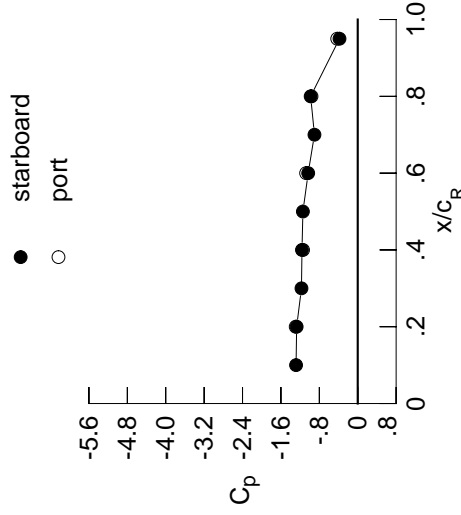

Table E2. Continued.

η	$x/c_R = .2$		$x/c_R = .4$		$x/c_R = .6$		$x/c_R = .8$		$x/c_R = .95$	
	$C_{p,u}$	$C_{p,u}$	$C_{p,u}$	$C_{p,u}$	$C_{p,u}$	$C_{p,u}$	$C_{p,u}$	$C_{p,u}$	$C_{p,u}$	$C_{p,u}$
0.050	-0.3993	-0.4741	-0.2102	*****	*****	*****	*****	*****	*****	*****
0.100	-0.3782	-0.4714	-0.2236	*****	*****	*****	*****	*****	*****	*****
0.150	-0.4366	-0.4862	-0.2485	*****	*****	*****	*****	*****	*****	*****
0.200	-0.4506	-0.4872	-0.2878	*****	*****	*****	*****	*****	*****	-0.4833
0.250	*****	-0.4884	-0.3068	-0.5160	-0.5706	*****	*****	*****	*****	-0.5706
0.300	-0.4450	-0.4875	-0.3390	-0.5084	-0.6255	*****	*****	*****	*****	-0.6255
0.350	*****	-0.4883	-0.3814	-0.5134	-0.6429	*****	*****	*****	*****	-0.6429
0.400	-0.4694	-0.5055	-0.4492	-0.5468	-0.6908	*****	*****	*****	*****	-0.6908
0.450	-0.4737	-0.5694	-0.5598	-0.6337	-0.7629	*****	*****	*****	*****	-0.7629
0.500	-0.4677	-0.7641	-0.7985	-0.8033	-0.9213	*****	*****	*****	*****	-0.9213
0.525	*****	-0.9328	-0.9511	-0.9158	-1.0230	*****	*****	*****	*****	-1.0230
0.550	-0.5988	-1.1089	-1.1107	-1.0427	-1.1432	*****	*****	*****	*****	-1.1432
0.575	-1.2597	-1.2699	-1.2550	-1.1702	-1.0429	*****	*****	*****	*****	-1.0429
0.600	-1.2597	-1.3947	-1.3960	-1.2920	-0.7374	*****	*****	*****	*****	-0.7374
0.625	*****	*****	-1.4951	-1.3937	-0.6743	*****	*****	*****	*****	-0.6743
0.650	-1.6101	-1.5865	-1.2423	-1.1410	-0.6419	*****	*****	*****	*****	-0.6419
0.675	*****	-1.6109	-1.2103	-1.0891	-0.6306	*****	*****	*****	*****	-0.6306
0.700	-1.5373	-1.4398	-1.2124	-1.0922	-0.6190	*****	*****	*****	*****	-0.6190
0.725	*****	-1.4031	*****	-1.0988	-0.5933	*****	*****	*****	*****	-0.5933
0.750	-1.4849	-1.3990	*****	-1.1017	-0.5637	*****	*****	*****	*****	-0.5637
0.775	*****	-1.3721	-1.2534	-1.1106	-0.5214	*****	*****	*****	*****	-0.5214
0.800	-1.4865	-1.3477	-1.2999	-1.1305	*****	*****	*****	*****	*****	*****
0.825	*****	-1.3476	-1.3018	-1.1180	-0.4825	*****	*****	*****	*****	-0.4825
0.850	-1.3599	-1.3212	-1.2104	-1.0862	-0.4564	*****	*****	*****	*****	-0.4564
0.875	*****	-1.2302	-1.1391	-1.0132	-0.4539	*****	*****	*****	*****	-0.4539
0.900	-1.2824	-1.1718	-1.1241	-0.9682	-0.4448	*****	*****	*****	*****	-0.4448
0.925	*****	-1.1664	-1.1391	-0.9623	-0.4308	*****	*****	*****	*****	-0.4308
0.950	-1.2401	-1.1648	-1.1411	-0.9840	-0.3898	*****	*****	*****	*****	-0.3898
0.975	*****	-1.1604	-1.1332	-0.9761	-0.3629	*****	*****	*****	*****	-0.3629
1.000	-1.2725	-1.1613	-1.0323	-0.9807	-0.3804	*****	*****	*****	*****	-0.3804
	$C_{p,l}$	$C_{p,l}$	$C_{p,l}$	$C_{p,l}$	$C_{p,l}$	$C_{p,l}$	$C_{p,l}$	$C_{p,l}$	$C_{p,l}$	$C_{p,l}$
-0.200	0.4436	0.3963	0.3826	*****	-0.5522	*****	*****	*****	*****	-0.5522
-0.400	0.4483	0.4010	0.3554	0.1679	-0.6154	*****	*****	*****	*****	-0.6154
-0.600	0.4606	0.4067	0.3520	0.1971	-0.5917	*****	*****	*****	*****	-0.5917
-0.700	0.4640	0.4113	0.3513	0.2108	-0.5605	*****	*****	*****	*****	-0.5605
-0.800	0.4492	0.4111	0.3536	0.2306	-0.4791	*****	*****	*****	*****	-0.4791
-0.850	0.4212	0.4018	0.3495	0.2383	-0.4616	*****	*****	*****	*****	-0.4616
-0.900	*****	0.3622	0.3256	0.2389	-0.4112	*****	*****	*****	*****	-0.4112
-0.950	0.2119	0.2368	0.2202	0.1804	-0.1383	*****	*****	*****	*****	-0.1383
-0.975	*****	0.0376	0.0476	0.0479	-0.0723	*****	*****	*****	*****	-0.0723
-1.000	-1.2924	-1.1391	-1.0750	-0.9633	-0.4271	*****	*****	*****	*****	-0.4271

Medium Radius L.E.
 Run No. = 10 , Point No. = 210
 $C_N = 0.932$, $C_m = -0.1526$
 $\alpha = 18.9^\circ$, $M_\infty = 0.849$
 $R_{mac} = 11.7 \times 10^6$

Leading Edge Pressures



x/c_R	starb'd C_p	port C_p
0.10	-1.2848	*****
0.20	-1.2725	-1.2924
0.30	-1.1723	*****
0.40	-1.1613	-1.1391
0.50	-1.1422	*****
0.60	-1.0323	-1.0750
0.70	-0.9018	*****
0.80	-0.9807	-0.9633
0.90	*****	*****
0.95	-0.3804	-0.4271

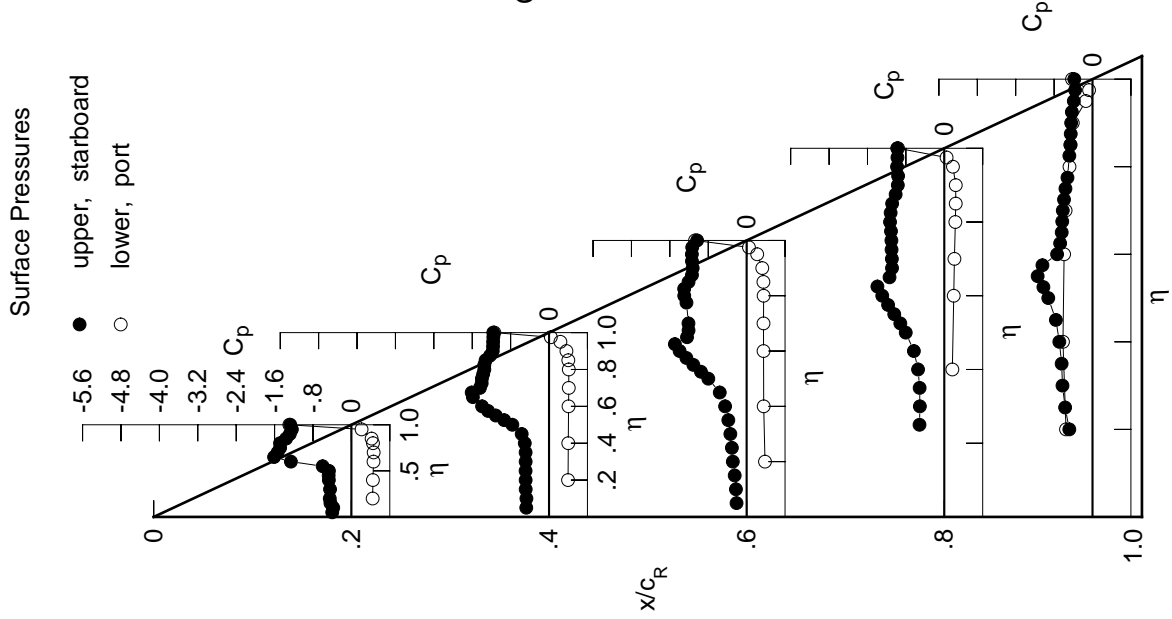

Table E2. Continued.

η	x/c_R .2	x/c_R .4	x/c_R .6	x/c_R .8	x/c_R .95
	$C_{p,u}$	$C_{p,u}$	$C_{p,u}$	$C_{p,u}$	$C_{p,u}$
0.050	-0.4686	-0.5379	-0.5168	*****	*****
0.100	-0.4391	-0.5359	-0.5284	*****	*****
0.150	-0.5088	-0.5535	-0.5379	*****	*****
0.200	-0.4987	-0.5540	-0.5482	*****	-0.3323
0.250	*****	-0.5624	-0.5578	-0.5834	-0.4619
0.300	-0.5001	-0.5733	-0.5841	-0.5924	-0.5303
0.350	*****	-0.6001	-0.6309	-0.6262	-0.5755
0.400	-0.5311	-0.6739	-0.7267	-0.6948	-0.6513
0.450	-0.5655	-0.8239	-0.8909	-0.8184	-0.7669
0.500	-0.7180	-1.0646	-1.1357	-1.0079	-0.9633
0.525	*****	-1.1997	-1.2606	-1.1184	-1.0729
0.550	-1.1647	-1.3283	-1.3757	-1.2301	-1.1933
0.575	*****	-1.4390	-1.4715	-1.3372	-0.9780
0.600	-1.5739	-1.5290	-1.5610	-1.4331	-0.7444
0.625	*****	*****	-1.5491	-1.5087	-0.6736
0.650	-1.7497	-1.4274	-1.3594	-1.2402	-0.6612
0.675	*****	-1.3992	-1.3481	-1.2012	-0.6399
0.700	-1.6949	-1.3926	-1.3364	-1.1852	-0.5956
0.725	*****	-1.4020	*****	-1.1723	-0.5532
0.750	-1.5349	-1.4126	*****	-1.1650	-0.5246
0.775	*****	-1.4413	-1.3561	-1.1658	-0.5163
0.800	-1.4824	-1.4676	-1.3940	-1.1854	*****
0.825	*****	-1.4084	-1.3873	-1.1883	-0.5554
0.850	-1.3635	-1.3190	-1.3099	-1.1682	-0.5319
0.875	*****	-1.2729	-1.2420	-1.0670	-0.5314
0.900	-1.3127	-1.2751	-1.2196	-0.9763	-0.5160
0.925	*****	-1.2828	-1.2231	-0.9576	-0.5087
0.950	-1.2572	-1.2788	-1.2245	-0.9853	-0.4451
0.975	*****	-1.2729	-1.2135	-0.9867	-0.4034
1.000	-1.2775	-1.2804	-1.1043	-0.9749	-0.4061
	$C_{p,l}$	$C_{p,l}$	$C_{p,l}$	$C_{p,l}$	$C_{p,l}$
-0.200	0.5008	0.4460	0.4197	*****	-0.5291
-0.400	0.5058	0.4489	0.3940	0.2010	-0.5914
-0.600	0.5140	0.4516	0.3876	0.2282	-0.5652
-0.700	0.5116	0.4540	0.3872	0.2414	-0.5339
-0.800	0.4838	0.4459	0.3843	0.2560	-0.4524
-0.850	0.4464	0.4282	0.3740	0.2603	-0.4334
-0.900	*****	0.3735	0.3382	0.2536	-0.3811
-0.950	0.1979	0.2214	0.2070	0.1725	-0.1285
-0.975	*****	-0.0039	0.0104	0.0163	-0.0851
-1.000	-1.3110	-1.2966	-1.2208	-0.9824	-0.4337

Medium Radius L.E.
 Run No. = 10, Point No. = 211
 $C_N = 1.047$, $C_m = -0.1728$
 $\alpha = 21.0^\circ$, $M_\infty = 0.850$
 $R_{mac} = 11.7 \times 10^6$

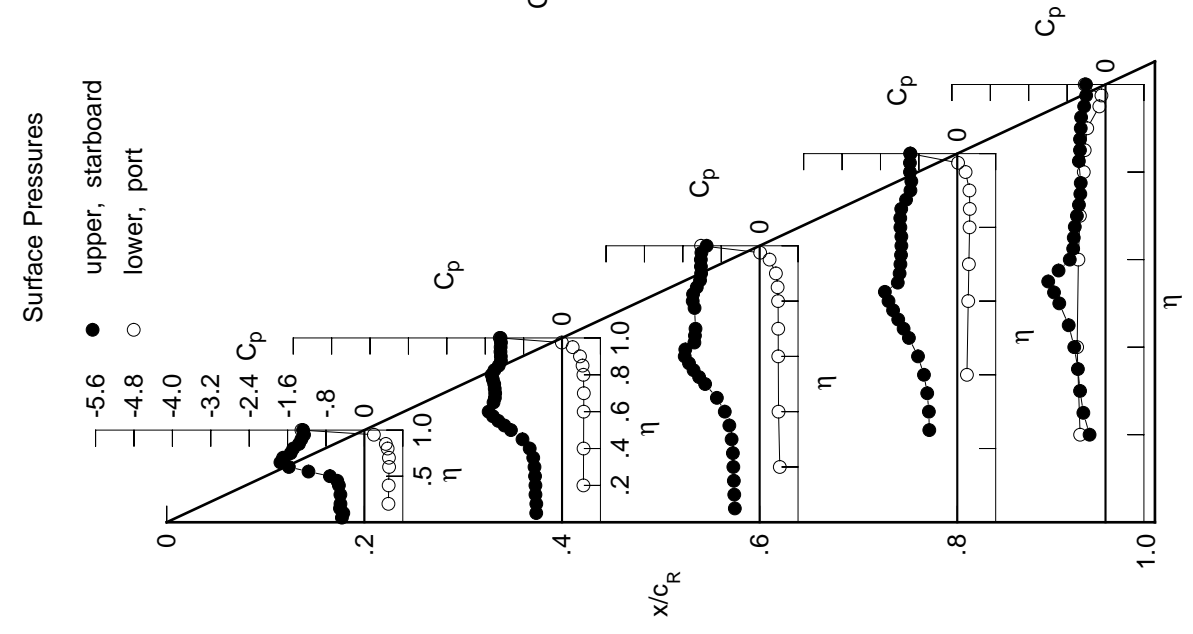
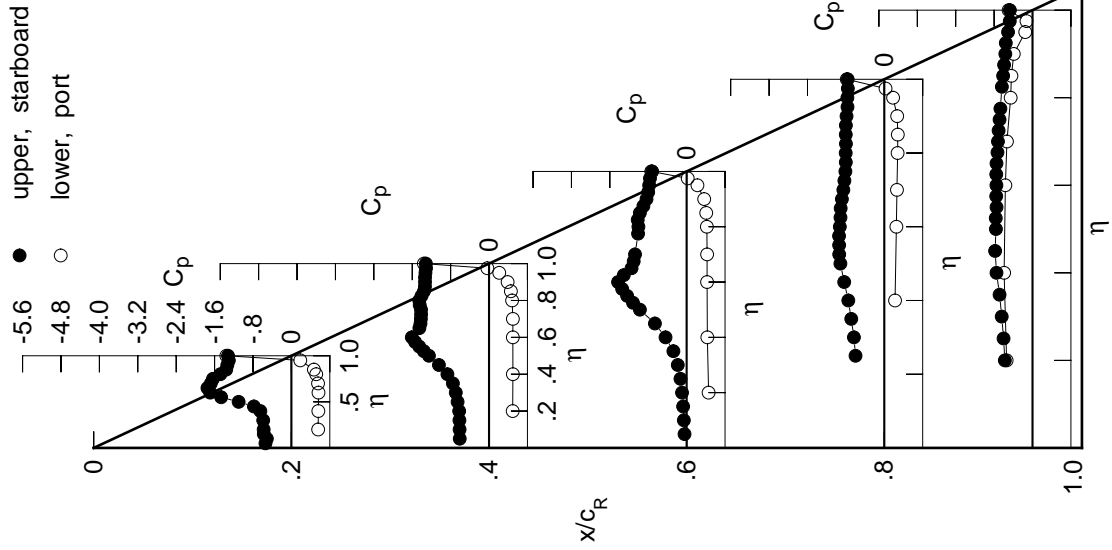

Table E2. Continued.

η	x/c_R .2	x/c_R .4	x/c_R .6	x/c_R .8	x/c_R .95
	$C_{p,u}$	$C_{p,u}$	$C_{p,u}$	$C_{p,u}$	$C_{p,u}$
0.050	-0.5400	-0.6102	-0.0443	*****	*****
0.100	-0.5112	-0.6134	-0.0586	*****	*****
0.150	-0.5742	-0.6165	-0.0739	*****	*****
0.200	-0.5773	-0.6226	-0.0956	*****	-0.5759
0.250	*****	-0.6551	-0.1289	-0.5991	-0.6034
0.300	-0.5873	-0.6930	-0.1845	-0.6328	-0.6412
0.350	*****	-0.7526	-0.2760	-0.6883	-0.6863
0.400	-0.6465	-0.8669	-0.4401	-0.7497	-0.7501
0.450	-0.7809	-1.0443	-0.6611	-0.8354	-0.7789
0.500	-1.0994	-1.2518	-0.9734	-0.9143	-0.7622
0.525	*****	-1.3583	-1.1176	-0.9394	-0.7655
0.550	-1.4636	-1.4537	-1.2399	-0.9411	-0.7496
0.575	*****	-1.5407	-1.3433	-0.9422	-0.7557
0.600	-1.6915	-1.6085	-1.4286	-0.9261	-0.7521
0.625	*****	*****	-1.3093	-0.9127	-0.7555
0.650	-1.7488	-1.4512	-1.1475	-0.9091	-0.7505
0.675	*****	-1.4280	-1.1028	-0.8831	-0.7296
0.700	-1.6787	-1.4201	-1.0756	-0.8528	-0.7196
0.725	*****	-1.4161	*****	-0.8314	-0.7061
0.750	-1.6333	-1.4171	*****	-0.8102	-0.6864
0.775	*****	-1.4439	-1.0120	-0.8013	-0.6691
0.800	-1.4785	-1.4535	-1.0050	-0.8038	*****
0.825	*****	-1.4066	-1.0195	-0.7996	-0.6385
0.850	-1.3575	-1.3562	-0.9747	-0.8020	-0.6120
0.875	*****	-1.3352	-0.9009	-0.7998	-0.5924
0.900	-1.3348	-1.3333	-0.8359	-0.7866	-0.5663
0.925	*****	-1.3335	-0.8011	-0.7666	-0.5571
0.950	-1.3031	-1.3246	-0.7812	-0.7692	-0.5093
0.975	*****	-1.3126	-0.7641	-0.7594	-0.4737
1.000	-1.3201	-1.3160	-0.7184	-0.7624	-0.4713
	$C_{p,l}$	$C_{p,l}$	$C_{p,l}$	$C_{p,l}$	$C_{p,l}$
-0.200	0.5579	0.4928	0.4577	*****	-0.5395
-0.400	0.5613	0.4971	0.4313	0.2243	-0.5915
-0.600	0.5645	0.4960	0.4259	0.2518	-0.5653
-0.700	0.5552	0.4967	0.4261	0.2636	-0.5328
-0.800	0.5164	0.4804	0.4211	0.2779	-0.4551
-0.850	0.4691	0.4550	0.4083	0.2813	-0.4393
-0.900	*****	0.3872	0.3658	0.2688	-0.3901
-0.950	0.1845	0.2124	0.2245	0.1829	-0.1513
-0.975	*****	-0.0351	0.0227	0.0253	-0.1254
-1.000	-1.3554	-1.3580	-0.7367	-0.7812	-0.4976

Surface Pressures



Medium Radius L.E.
 Run No. = 10, Point No. = 212
 $C_N = 1.054$, $C_m = -0.1727$
 $\alpha = 23.0^\circ$, $M_\infty = 0.850$
 $R_{mac} = 11.7 \times 10^6$

Leading Edge Pressures

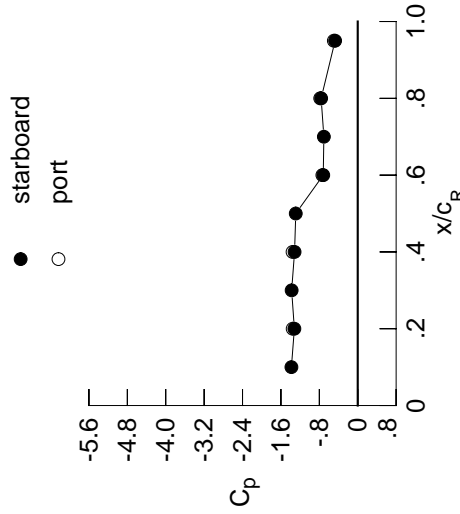

x/c_R	starb'd C_p	port C_p
0.10	-1.3817	*****
0.20	-1.3201	-1.3554
0.30	-1.3767	*****
0.40	-1.3160	-1.3580
0.50	-1.2908	*****
0.60	-0.7184	-0.7367
0.70	-0.7054	*****
0.80	-0.7624	-0.7812
0.90	*****	*****
0.95	-0.4713	-0.4976

Table E2. Continued.

η	$x/c_R = 0.2$		$x/c_R = 0.4$		$x/c_R = 0.6$		$x/c_R = 0.8$		$x/c_R = 0.95$	
	$C_{p,u}$	$C_{p,u}$	$C_{p,u}$	$C_{p,u}$	$C_{p,u}$	$C_{p,u}$	$C_{p,u}$	$C_{p,u}$	$C_{p,u}$	$C_{p,u}$
0.050	-0.6367	-0.6786	0.0003	*****	*****	*****	*****	*****	*****	*****
0.100	-0.6169	-0.6854	-0.0091	*****	*****	*****	*****	*****	*****	*****
0.150	-0.6436	-0.6957	-0.0218	*****	*****	*****	*****	*****	*****	*****
0.200	-0.6526	-0.7107	-0.0424	*****	*****	*****	*****	*****	*****	-0.6327
0.250	*****	-0.7490	-0.0821	-0.9803	-0.7372	*****	*****	*****	*****	*****
0.300	-0.7117	-0.8019	-0.1554	-1.0116	-0.8261	*****	*****	*****	*****	*****
0.350	*****	-0.8960	-0.2795	-1.0435	-0.8744	*****	*****	*****	*****	*****
0.400	-0.8972	-1.0354	-0.4793	-1.0508	-0.8729	*****	*****	*****	*****	*****
0.450	-1.1295	-1.2194	-0.7255	-1.0251	-0.7933	*****	*****	*****	*****	*****
0.500	-1.4212	-1.4030	-1.0162	-0.9713	-0.7414	*****	*****	*****	*****	*****
0.525	*****	-1.4886	-1.1451	-0.9534	-0.7486	*****	*****	*****	*****	*****
0.550	-1.6397	-1.5627	-1.2546	-0.9392	-0.7510	*****	*****	*****	*****	*****
0.575	*****	-1.6291	-1.3431	-0.9555	-0.7705	*****	*****	*****	*****	*****
0.600	-1.7552	-1.6670	-1.4133	-0.9766	-0.7750	*****	*****	*****	*****	*****
0.625	*****	*****	-1.3347	-0.9748	-0.7807	*****	*****	*****	*****	*****
0.650	-1.6599	-1.4985	-1.1248	-0.9704	-0.7765	*****	*****	*****	*****	*****
0.675	*****	-1.4768	-1.0361	-0.9700	-0.7580	*****	*****	*****	*****	*****
0.700	-1.6640	-1.4691	-0.9632	-0.9703	-0.7554	*****	*****	*****	*****	*****
0.725	*****	-1.4677	*****	-0.9610	-0.7481	*****	*****	*****	*****	*****
0.750	-1.6647	-1.4684	*****	-0.9381	-0.7331	*****	*****	*****	*****	*****
0.775	*****	-1.4952	-0.8606	-0.9216	-0.7135	*****	*****	*****	*****	*****
0.800	-1.4872	-1.5122	-0.8377	-0.9080	*****	*****	*****	*****	*****	*****
0.825	*****	-1.4689	-0.8299	-0.9058	-0.6767	*****	*****	*****	*****	*****
0.850	-1.3907	-1.4158	-0.8209	-0.8886	-0.6520	*****	*****	*****	*****	*****
0.875	*****	-1.3900	-0.8018	-0.8779	-0.6315	*****	*****	*****	*****	*****
0.900	-1.3750	-1.3921	-0.7711	-0.8630	-0.6075	*****	*****	*****	*****	*****
0.925	*****	-1.3967	-0.7425	-0.8396	-0.5917	*****	*****	*****	*****	*****
0.950	-1.3595	-1.3908	-0.7273	-0.8249	-0.5485	*****	*****	*****	*****	*****
0.975	*****	-1.3791	-0.7189	-0.7970	-0.5072	*****	*****	*****	*****	*****
1.000	-1.3872	-1.3826	-0.6843	-0.7967	-0.4906	*****	*****	*****	*****	*****
-0.200	$C_{p,l}$	$C_{p,l}$	$C_{p,l}$	$C_{p,l}$	$C_{p,l}$	$C_{p,l}$	$C_{p,l}$	$C_{p,l}$	$C_{p,l}$	$C_{p,l}$
-0.400	0.6146	0.5418	0.4954	*****	*****	*****	*****	*****	*****	-0.5187
-0.600	0.6171	0.5447	0.4706	0.2586	-0.5619	*****	*****	*****	*****	*****
-0.700	0.6146	0.5401	0.4637	0.2836	-0.5391	*****	*****	*****	*****	*****
-0.800	0.5983	0.5381	0.4597	0.2941	-0.5035	*****	*****	*****	*****	*****
-0.850	0.5466	0.5136	0.4507	0.3050	-0.4280	*****	*****	*****	*****	*****
-0.900	0.4900	0.4784	0.4322	0.3039	-0.4129	*****	*****	*****	*****	*****
-0.950	0.1667	0.1991	0.2155	0.2825	-0.3658	*****	*****	*****	*****	*****
-0.975	*****	-0.0691	-0.0036	-0.0021	-0.1419	*****	*****	*****	*****	*****
-1.000	-1.4546	-1.4213	-0.7631	-0.7594	-0.5173	*****	*****	*****	*****	*****

Medium Radius L.E.
 Run No. = 10, Point No. = 213
 $C_N = 1.144$, $C_m = -0.1826$
 $\alpha = 25.1^\circ$, $M_\infty = 0.849$
 $R_{mac} = 11.6 \times 10^6$

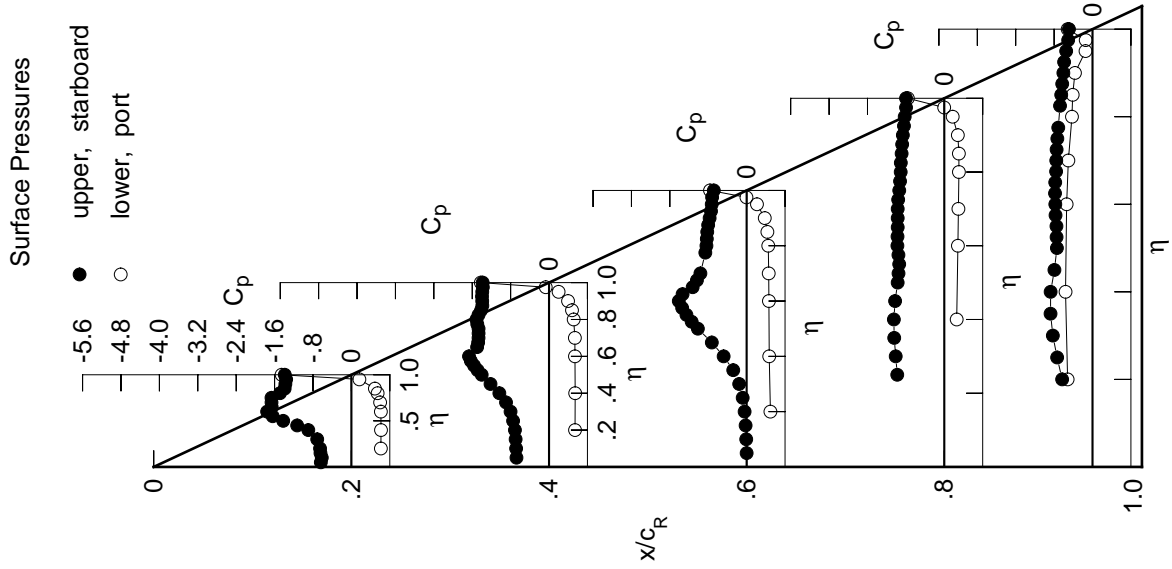
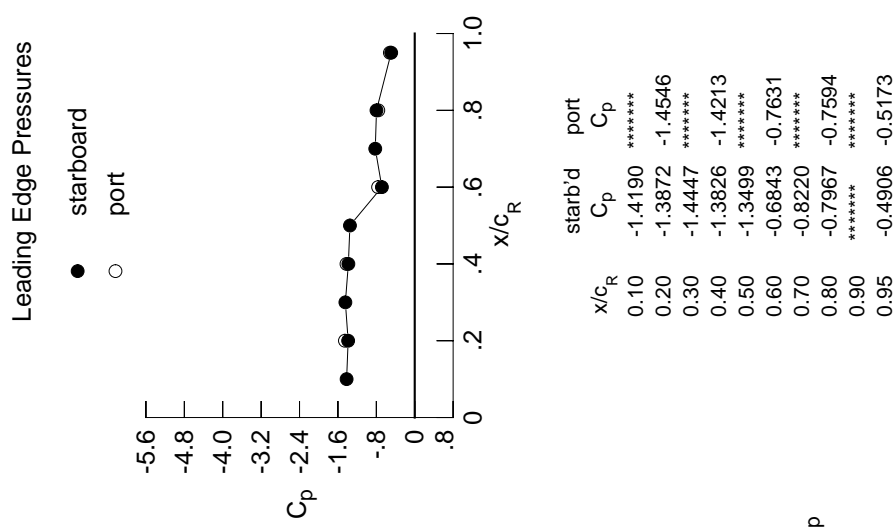
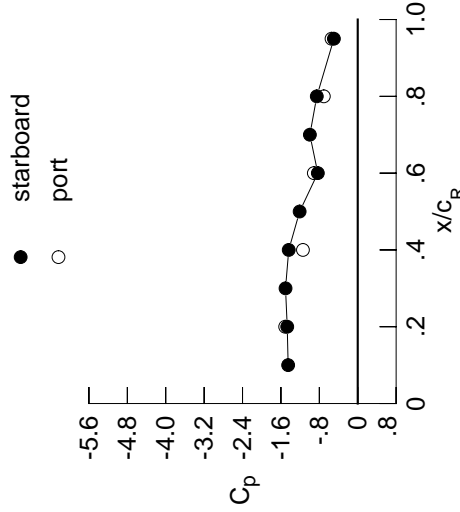

Table E2. Concluded.

η	$x/c_R = .2$		$x/c_R = .4$		$x/c_R = .6$		$x/c_R = .8$		$x/c_R = .95$	
	$C_{p,u}$	$C_{p,u}$	$C_{p,u}$	$C_{p,u}$	$C_{p,u}$	$C_{p,u}$	$C_{p,u}$	$C_{p,u}$	$C_{p,u}$	$C_{p,u}$
0.050	-0.7260	-0.6469	-0.3789	*****	*****	*****	*****	*****	*****	*****
0.100	-0.6948	-0.6686	-0.3632	*****	*****	*****	*****	*****	*****	*****
0.150	-0.7479	-0.7220	-0.3470	*****	*****	*****	*****	*****	*****	*****
0.200	-0.7586	-0.7201	-0.3437	*****	*****	*****	*****	*****	*****	-0.6605
0.250	*****	-0.7782	-0.3588	-1.0120	-0.7597	*****	*****	*****	*****	*****
0.300	-0.8408	-0.8606	-0.4085	-1.0379	-0.8504	*****	*****	*****	*****	*****
0.350	*****	-0.9836	-0.5097	-1.0629	-0.9096	*****	*****	*****	*****	*****
0.400	-1.1162	-1.1424	-0.6738	-1.0498	-0.8822	*****	*****	*****	*****	*****
0.450	-1.3446	-1.3267	-0.8631	-1.0065	-0.7766	*****	*****	*****	*****	*****
0.500	-1.5600	-1.4897	-1.1120	-0.9551	-0.7246	*****	*****	*****	*****	*****
0.525	*****	-1.5592	-1.2189	-0.9511	-0.7389	*****	*****	*****	*****	*****
0.550	-1.7065	-1.6189	-1.2914	-0.9517	-0.7456	*****	*****	*****	*****	*****
0.575	*****	-1.6696	-1.3238	-0.9815	-0.7783	*****	*****	*****	*****	*****
0.600	-1.6836	-1.6820	-1.2996	-1.0133	-0.7935	*****	*****	*****	*****	*****
0.625	*****	*****	-1.2018	-1.0277	-0.8097	*****	*****	*****	*****	*****
0.650	-1.6258	-1.5350	-1.1066	-1.0400	-0.8047	*****	*****	*****	*****	*****
0.675	*****	-1.5157	-1.0834	-1.0449	-0.7808	*****	*****	*****	*****	*****
0.700	-1.6438	-1.5095	-1.0642	-1.0422	-0.7694	*****	*****	*****	*****	*****
0.725	*****	-1.5089	*****	-1.0325	-0.7568	*****	*****	*****	*****	*****
0.750	-1.6988	-1.5106	*****	-1.0072	-0.7386	*****	*****	*****	*****	*****
0.775	*****	-1.5288	-0.9948	-0.9932	-0.7178	*****	*****	*****	*****	*****
0.800	-1.5199	-1.5514	-0.9734	-0.9712	*****	*****	*****	*****	*****	*****
0.825	*****	-1.5175	-0.9639	-0.9740	-0.6742	*****	*****	*****	*****	*****
0.850	-1.4438	-1.4715	-0.9593	-0.9551	-0.6509	*****	*****	*****	*****	*****
0.875	*****	-1.4421	-0.9520	-0.9387	-0.6279	*****	*****	*****	*****	*****
0.900	-1.4402	-1.4397	-0.9224	-0.9178	-0.6044	*****	*****	*****	*****	*****
0.925	*****	-1.4433	-0.8915	-0.8868	-0.5903	*****	*****	*****	*****	*****
0.950	-1.4340	-1.4412	-0.8805	-0.8727	-0.5560	*****	*****	*****	*****	*****
0.975	*****	-1.4325	-0.8774	-0.8478	-0.5163	*****	*****	*****	*****	*****
1.000	-1.4686	-1.4374	-0.8316	-0.8526	-0.4965	*****	*****	*****	*****	*****
η	$C_{p,l}$	$C_{p,l}$	$C_{p,l}$	$C_{p,l}$	$C_{p,l}$	$C_{p,l}$	$C_{p,l}$	$C_{p,l}$	$C_{p,l}$	$C_{p,l}$
-0.200	0.6672	0.5887	0.5327	*****	-0.4997	*****	*****	*****	*****	*****
-0.400	0.6704	0.5889	0.5073	0.2912	-0.5390	*****	*****	*****	*****	*****
-0.600	0.6612	0.5830	0.4970	0.3141	-0.5110	*****	*****	*****	*****	*****
-0.700	0.6379	0.5789	0.4921	0.3218	-0.4808	*****	*****	*****	*****	*****
-0.800	0.5734	0.5456	0.4763	0.3292	-0.4031	*****	*****	*****	*****	*****
-0.850	0.5071	0.5032	0.4508	0.3264	-0.3894	*****	*****	*****	*****	*****
-0.900	*****	0.4088	0.3842	0.2979	-0.3434	*****	*****	*****	*****	*****
-0.950	0.1496	0.1940	0.1989	0.1738	-0.1396	*****	*****	*****	*****	*****
-0.975	*****	-0.0892	-0.0418	-0.0156	-0.1546	*****	*****	*****	*****	*****
-1.000	-1.5110	-1.1414	-0.9141	-0.7062	-0.5455	*****	*****	*****	*****	*****

Medium Radius L.E.
 Run No. = 10 , Point No. = 214
 $C_N = 1.213$, $C_m = -0.1970$
 $\alpha = 27.1^\circ$, $M_\infty = 0.849$
 $R_{mac} = 11.6 \times 10^6$

Leading Edge Pressures



x/c_R	starb'd C_p	port C_p
0.10	-1.4497	*****
0.20	-1.4686	-1.5110
0.30	-1.5044	*****
0.40	-1.4374	-1.1414
0.50	-1.2101	*****
0.60	-0.8316	-0.9141
0.70	-0.9970	*****
0.80	-0.8526	-0.7062
0.90	*****	*****
0.95	-0.4965	-0.5455

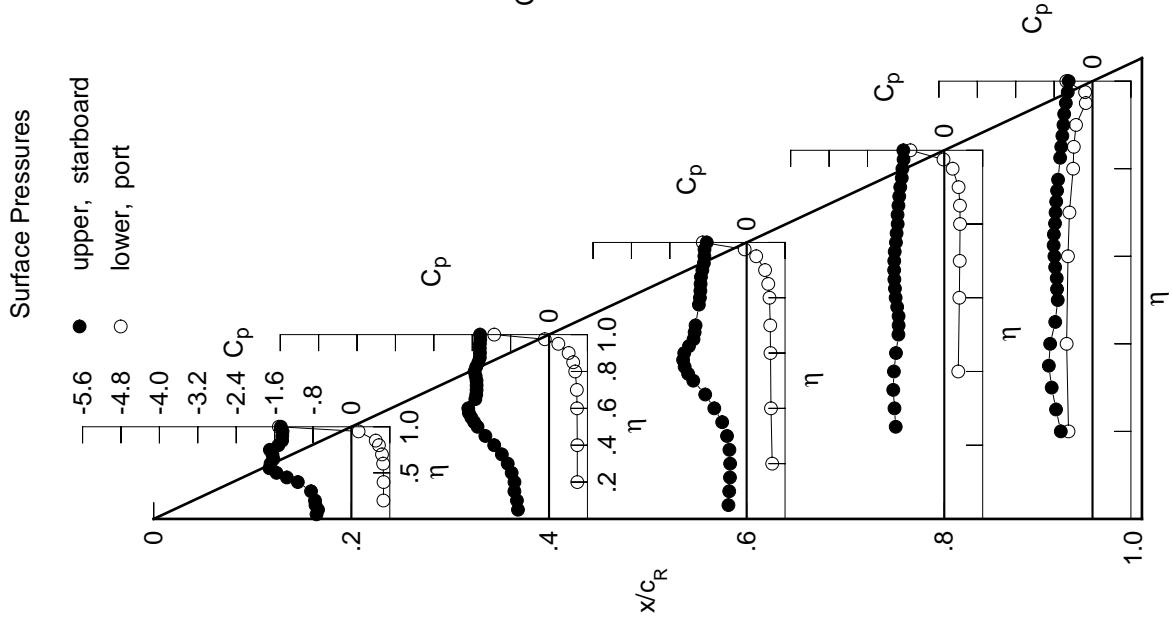
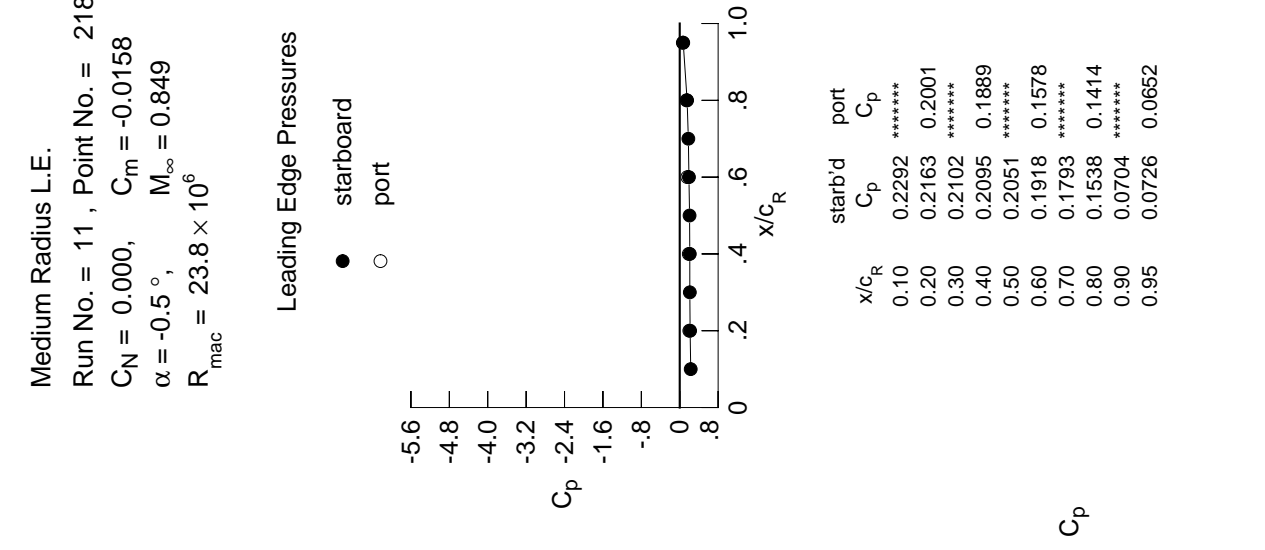
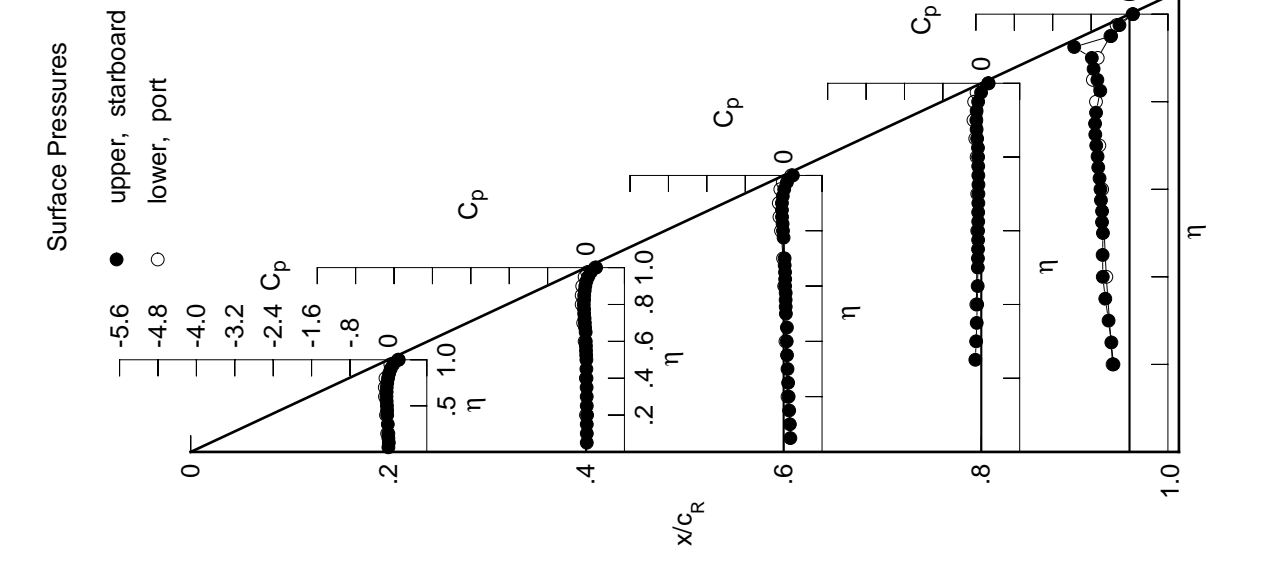

Table E3. Tabulations and Plots of Surface Pressure Coefficients.

η	x/c_R .2	x/c_R .4	x/c_R .6	x/c_R .8	x/c_R .95
	$C_{p,u}$	$C_{p,u}$	$C_{p,u}$	$C_{p,u}$	$C_{p,u}$
0.050	0.0002	0.0151	0.1400	0.4000	0.5000
0.100	0.0086	0.0156	0.1297	0.3800	0.4500
0.150	-0.0002	0.0152	0.1152	0.3500	0.4000
0.200	-0.0008	0.0218	0.1040	0.3200	0.3500
0.250	0.0000	0.0149	0.0938	0.2900	0.3000
0.300	-0.0121	0.0148	0.0810	0.2600	0.2500
0.350	0.0000	0.0120	0.0701	0.2300	0.2000
0.400	-0.0246	0.0098	0.0643	0.2000	0.1500
0.450	-0.0264	0.0072	0.0683	0.1700	0.1000
0.500	-0.0300	0.0072	0.0467	0.1400	0.0500
0.525	0.0000	0.0035	0.0435	0.1100	0.0000
0.550	-0.0363	-0.0004	0.0414	0.0800	-0.0500
0.575	0.0000	-0.0025	0.0426	0.0500	-0.1000
0.600	-0.0402	-0.0053	0.0301	0.0200	-0.1500
0.625	0.0000	0.0000	0.0316	0.0000	-0.2000
0.650	-0.0371	-0.0080	0.0290	-0.0200	-0.2500
0.675	0.0000	-0.0203	0.0220	-0.0400	-0.3000
0.700	-0.0351	-0.0251	0.0197	-0.0500	-0.3500
0.725	0.0000	-0.0307	0.0177	-0.0600	-0.4000
0.750	-0.0241	-0.0389	0.0148	-0.0700	-0.4500
0.775	0.0000	-0.0406	0.0118	-0.0800	-0.5000
0.800	-0.0070	-0.0472	0.0133	-0.0900	-0.5500
0.825	0.0000	-0.0409	0.0217	-0.0688	-0.6100
0.850	0.0146	-0.0382	0.0332	-0.0867	-0.6700
0.875	0.0000	-0.0279	0.0355	-0.0977	-0.7483
0.900	0.0469	-0.0149	0.0357	-0.1029	-0.7859
0.925	0.0000	0.0058	0.0182	-0.0979	-1.1521
0.950	0.1007	0.0444	0.0118	-0.0660	-0.3836
0.975	0.0000	0.0984	0.0679	-0.0036	-0.2097
1.000	0.2163	0.2095	0.1918	0.1538	0.0726



Medium Radius L.E.
 Run No. = 11, Point No. = 218
 $C_N = 0.000$, $C_m = -0.0158$
 $\alpha = -0.5^\circ$, $M_\infty = 0.849$
 $R_{mac} = 23.8 \times 10^6$

Table E3. Continued.

η	$x/c_R = 0.2$		$x/c_R = 0.4$		$x/c_R = 0.6$		$x/c_R = 0.8$		$x/c_R = 0.95$	
	$C_{p,u}$	$C_{p,d}$	$C_{p,u}$	$C_{p,d}$	$C_{p,u}$	$C_{p,d}$	$C_{p,u}$	$C_{p,d}$	$C_{p,u}$	$C_{p,d}$
0.050	-0.0034	0.0100	0.1368	*****	*****	*****	*****	*****	*****	*****
0.100	0.0049	0.0107	0.1262	*****	*****	*****	*****	*****	*****	*****
0.150	-0.0056	0.0109	0.1120	*****	*****	*****	*****	*****	*****	*****
0.200	-0.0067	0.0175	0.0994	*****	*****	*****	*****	*****	*****	-0.3285
0.250	*****	0.0102	0.0904	-0.1275	-0.1105	-0.4238	*****	*****	*****	-0.3704
0.300	-0.0162	0.0089	0.0778	-0.1105	-0.1105	-0.4238	*****	*****	*****	-0.4238
0.350	*****	0.0072	0.0666	-0.0994	-0.4885	*****	*****	*****	*****	-0.4885
0.400	-0.0299	0.0041	0.0582	-0.0863	-0.5479	*****	*****	*****	*****	-0.5479
0.450	-0.0335	0.0042	0.0637	-0.0797	-0.5634	*****	*****	*****	*****	-0.5634
0.500	-0.0360	0.0018	0.0429	-0.0747	-0.5568	*****	*****	*****	*****	-0.5568
0.525	*****	-0.0008	0.0405	-0.0742	-0.5738	*****	*****	*****	*****	-0.5738
0.550	-0.0430	-0.0069	0.0378	-0.0690	-0.5699	*****	*****	*****	*****	-0.5699
0.575	*****	-0.0081	0.0393	-0.0699	-0.5935	*****	*****	*****	*****	-0.5935
0.600	-0.0472	-0.0124	0.0266	-0.0712	-0.6040	*****	*****	*****	*****	-0.6040
0.625	*****	*****	0.0280	-0.0670	-0.6257	*****	*****	*****	*****	-0.6257
0.650	-0.0457	-0.0142	0.0223	-0.0677	-0.6522	*****	*****	*****	*****	-0.6522
0.675	*****	-0.0270	0.0168	-0.0673	-0.6670	*****	*****	*****	*****	-0.6670
0.700	-0.0438	-0.0328	0.0133	-0.0653	-0.6940	*****	*****	*****	*****	-0.6940
0.725	*****	-0.0381	*****	-0.0657	-0.7143	*****	*****	*****	*****	-0.7143
0.750	-0.0342	-0.0469	*****	-0.0669	-0.7110	*****	*****	*****	*****	-0.7110
0.775	*****	-0.0501	-0.0092	-0.0703	-0.6648	*****	*****	*****	*****	-0.6648
0.800	-0.0175	-0.0547	-0.0214	-0.0734	*****	*****	*****	*****	*****	-0.0734
0.825	*****	-0.0536	-0.0327	-0.0751	-0.5485	*****	*****	*****	*****	-0.5485
0.850	0.0034	-0.0474	-0.0418	-0.0949	-0.6455	*****	*****	*****	*****	-0.6455
0.875	*****	-0.0403	-0.0488	-0.1062	-0.7567	*****	*****	*****	*****	-0.7567
0.900	0.0374	-0.0286	-0.0488	-0.1171	-0.7981	*****	*****	*****	*****	-0.7981
0.925	*****	-0.0096	-0.0347	-0.1123	-1.1603	*****	*****	*****	*****	-1.1603
0.950	0.0893	0.0303	-0.0028	-0.0832	-0.3920	*****	*****	*****	*****	-0.3920
0.975	*****	0.0853	0.0511	-0.0214	-0.2244	*****	*****	*****	*****	-0.2244
1.000	0.2193	0.2147	0.2038	0.1628	0.0805	*****	*****	*****	*****	0.0805
-0.200	$C_{p,l}$	$C_{p,l}$	$C_{p,l}$	$C_{p,l}$	$C_{p,l}$	$C_{p,l}$	$C_{p,l}$	$C_{p,l}$	$C_{p,l}$	$C_{p,l}$
-0.400	-0.0208	0.0039	0.0869	*****	*****	*****	*****	*****	*****	-0.3533
-0.600	-0.0433	0.0029	0.0427	-0.0976	-0.4964	*****	*****	*****	*****	-0.4964
-0.700	-0.0636	-0.0234	0.0169	-0.0780	-0.5992	*****	*****	*****	*****	-0.5992
-0.800	-0.0649	-0.0506	-0.0090	-0.0772	-0.6664	*****	*****	*****	*****	-0.6664
-0.850	-0.0488	-0.0794	-0.0453	-0.0898	-0.7104	*****	*****	*****	*****	-0.7104
-0.900	*****	-0.0789	-0.0742	-0.1165	-0.7594	*****	*****	*****	*****	-0.7594
-0.950	*****	-0.0637	-0.0860	-0.1478	-0.7525	*****	*****	*****	*****	-0.7525
-0.975	0.0561	-0.0115	-0.0490	-0.1298	-0.3860	*****	*****	*****	*****	-0.3860
-1.000	0.2060	0.1965	0.1704	0.1564	0.0766	*****	*****	*****	*****	0.0766

Medium Radius L.E.
 Run No. = 11 , Point No. = 219
 $C_N = 0.013$, $C_m = -0.0181$
 $\alpha = -0.2^\circ$, $M_\infty = 0.848$
 $R_{mac} = 23.9 \times 10^6$

Leading Edge Pressures
 ● starboard
 ○ port

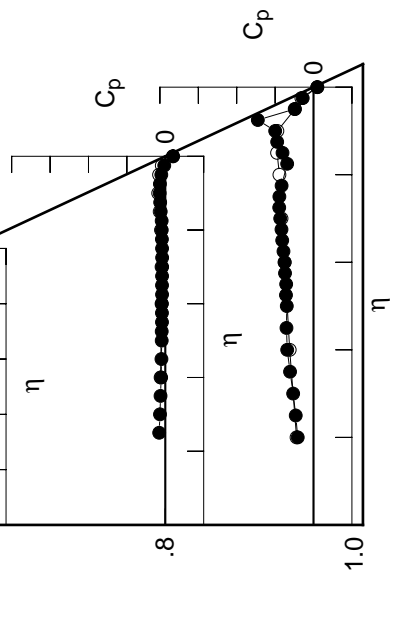
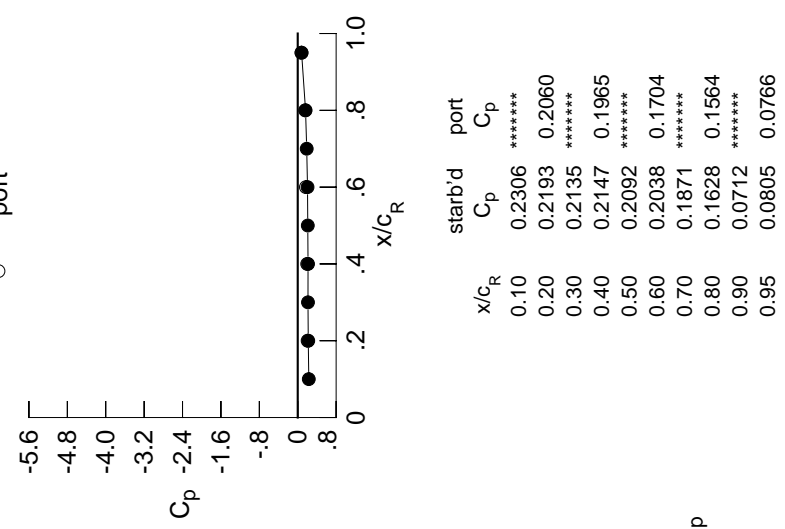

x/c_R	starb'd C_p	port C_p
0.10	0.2306	*****
0.20	0.2193	0.2060
0.30	0.2135	*****
0.40	0.2147	0.1965
0.50	0.2092	*****
0.60	0.2038	0.1704
0.70	0.1871	*****
0.80	0.1628	0.1564
0.90	0.0712	*****
0.95	0.0805	0.0766

Table E3. Continued.

η	x/c_R .2	x/c_R .4	x/c_R .6	x/c_R .8	x/c_R .95
	$C_{p,u}$	$C_{p,u}$	$C_{p,u}$	$C_{p,u}$	$C_{p,u}$
0.050	-0.0225	-0.0068	0.1223	*****	*****
0.100	-0.0154	-0.0080	0.1147	*****	*****
0.150	-0.0273	-0.0085	0.0980	*****	*****
0.200	-0.0247	-0.0038	0.0872	*****	-0.3251
0.250	*****	-0.0066	0.0719	-0.1390	-0.3593
0.300	-0.0396	-0.0096	0.0644	-0.1238	-0.4011
0.350	*****	-0.0119	0.0504	-0.1117	-0.4554
0.400	-0.0546	-0.0142	0.0431	-0.1016	-0.5100
0.450	-0.0574	-0.0177	0.0475	-0.0945	-0.5224
0.500	-0.0615	-0.0189	0.0252	-0.0915	-0.5117
0.525	*****	-0.0241	0.0211	-0.0882	-0.5287
0.550	-0.0710	-0.0279	0.0166	-0.0869	-0.5243
0.575	*****	-0.0327	0.0205	-0.0850	-0.5452
0.600	-0.0772	-0.0353	0.0040	-0.0891	-0.5547
0.625	*****	*****	0.0080	-0.0835	-0.5744
0.650	-0.0788	-0.0436	0.0009	-0.0858	-0.6100
0.675	*****	-0.0550	-0.0057	-0.0862	-0.6235
0.700	-0.0789	-0.0637	-0.0102	-0.0824	-0.6461
0.725	*****	-0.0708	*****	-0.0879	-0.6467
0.750	-0.0711	-0.0817	*****	-0.0897	-0.5924
0.775	*****	-0.0893	-0.0403	-0.0953	-0.4790
0.800	-0.0574	-0.0962	-0.0539	-0.1005	*****
0.825	*****	-0.0983	-0.0702	-0.1040	-0.3977
0.850	-0.0388	-0.0956	-0.0844	-0.1293	-0.5122
0.875	*****	-0.0920	-0.0967	-0.1465	-0.7531
0.900	-0.0094	-0.0824	-0.1039	-0.1637	-0.8236
0.925	*****	-0.0686	-0.0918	-0.1672	-1.1695
0.950	0.0404	-0.0305	-0.0737	-0.1486	-0.4308
0.975	*****	0.0179	-0.0195	-0.0963	-0.2799
1.000	0.2111	0.2017	0.1973	0.1487	0.0670
	$C_{p,l}$	$C_{p,l}$	$C_{p,l}$	$C_{p,l}$	$C_{p,l}$
-0.200	-0.0017	0.0199	0.0983	*****	-0.3672
-0.400	-0.0215	0.0209	0.0551	-0.0859	-0.5308
-0.600	-0.0355	-0.0002	0.0342	-0.0659	-0.6112
-0.700	-0.0326	-0.0235	0.0127	-0.0586	-0.6716
-0.800	-0.0104	-0.0428	-0.0155	-0.0670	-0.7049
-0.850	*****	-0.0359	-0.0349	-0.0846	-0.7389
-0.900	*****	-0.0136	-0.0374	-0.1021	-0.8115
-0.950	0.1011	0.0436	0.0114	-0.0686	-0.3528
-0.975	*****	0.1022	0.0688	-0.0062	-0.2006
-1.000	0.2049	0.1958	0.1686	0.1608	0.0803

Medium Radius L.E.
 Run No. = 11, Point No. = 220
 $C_N = 0.060$, $C_m = -0.0298$
 $\alpha = 0.8^\circ$, $M_\infty = 0.848$
 $R_{mac} = 24.0 \times 10^6$

Leading Edge Pressures

● starboard
 ○ port

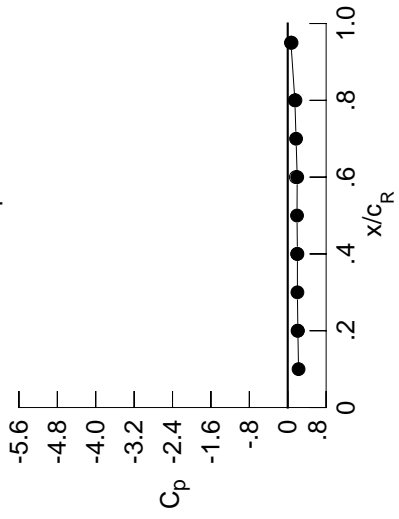

x/c_R	starb'd C_p	port C_p
0.10	0.2254	*****
0.20	0.2111	0.2049
0.30	0.2014	*****
0.40	0.2017	0.1958
0.50	0.1932	*****
0.60	0.1973	0.1686
0.70	0.1733	*****
0.80	0.1487	0.1608
0.90	0.0704	*****
0.95	0.0670	0.0803

Surface Pressures

● upper, starboard
 ○ lower, port

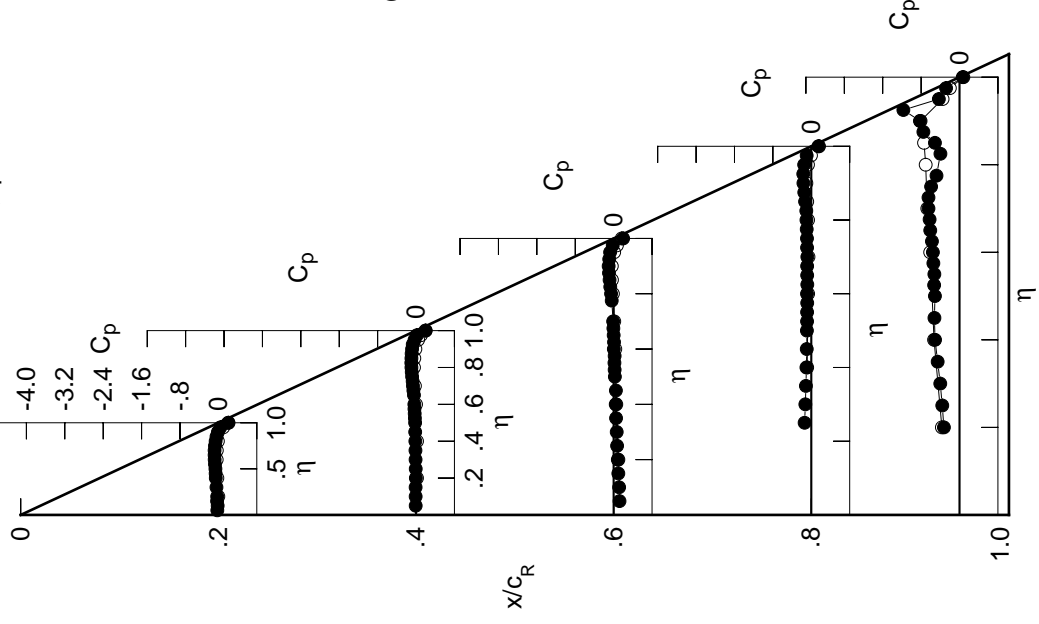

Table E3. Continued.

η	x/c_R .2	x/c_R .4	x/c_R .6	x/c_R .8	x/c_R .95
	$C_{p,u}$	$C_{p,u}$	$C_{p,u}$	$C_{p,u}$	$C_{p,u}$
0.050	-0.0416	-0.0250	0.1119	*****	*****
0.100	-0.0351	-0.0223	0.1011	*****	*****
0.150	-0.0448	-0.0249	0.0866	*****	*****
0.200	-0.0462	-0.0190	0.0750	*****	-0.3243
0.250	*****	-0.0248	0.0625	-0.1497	-0.3493
0.300	-0.0581	-0.0266	0.0499	-0.1372	-0.3853
0.350	*****	-0.0309	0.0385	-0.1247	-0.4375
0.400	-0.0758	-0.0325	0.0299	-0.1155	-0.4947
0.450	-0.0805	-0.0375	0.0329	-0.1046	-0.5109
0.500	-0.0878	-0.0393	0.0101	-0.1027	-0.5077
0.525	*****	-0.0459	0.0052	-0.1026	-0.5278
0.550	-0.0980	-0.0500	0.0020	-0.0998	-0.5276
0.575	*****	-0.0558	0.0033	-0.1008	-0.5514
0.600	-0.1060	-0.0586	-0.0114	-0.1022	-0.5648
0.625	*****	*****	-0.0101	-0.0995	-0.5927
0.650	-0.1102	-0.0665	-0.0175	-0.1032	-0.6222
0.675	*****	-0.0834	-0.0259	-0.1038	-0.6283
0.700	-0.1132	-0.0915	-0.0328	-0.1014	-0.6073
0.725	*****	-0.1036	*****	-0.1070	-0.5350
0.750	-0.1082	-0.1151	*****	-0.1105	-0.4274
0.775	*****	-0.1269	-0.0674	-0.1185	-0.3203
0.800	-0.0982	-0.1358	-0.0868	-0.1262	*****
0.825	*****	-0.1423	-0.1075	-0.1323	-0.3158
0.850	-0.0827	-0.1439	-0.1270	-0.1637	-0.3571
0.875	*****	-0.1434	-0.1456	-0.1891	-0.5853
0.900	-0.0582	-0.1396	-0.1591	-0.2145	-0.7771
0.925	*****	-0.1316	-0.1574	-0.2270	-1.1517
0.950	-0.0133	-0.1023	-0.1464	-0.2204	-0.4698
0.975	*****	-0.0599	-0.1092	-0.1841	-0.3433
1.000	0.1783	0.1422	0.1202	0.0619	0.0042
	$C_{p,l}$	$C_{p,l}$	$C_{p,l}$	$C_{p,l}$	$C_{p,l}$
-0.200	0.0205	0.0383	0.1138	*****	-0.3945
-0.400	0.0025	0.0415	0.0715	-0.0738	-0.5837
-0.600	-0.0052	0.0239	0.0533	-0.0464	-0.6875
-0.700	0.0013	0.0062	0.0368	-0.0422	-0.7230
-0.800	0.0277	-0.0046	0.0160	-0.0405	-0.6926
-0.850	*****	0.0074	0.0043	-0.0526	-0.7125
-0.900	*****	0.0343	0.0105	-0.0588	-0.7681
-0.950	0.1413	0.0951	0.0663	-0.0132	-0.3184
-0.975	*****	0.1508	0.1236	0.0523	-0.1555
-1.000	0.1768	0.1452	0.0971	0.0921	0.0327

Medium Radius L.E.
 Run No. = 11, Point No. = 221
 $C_N = 0.097$, $C_m = -0.0335$
 $\alpha = 1.9^\circ$, $M_\infty = 0.852$
 $R_{mac} = 24.2 \times 10^6$

Leading Edge Pressures

● starboard
 ○ port

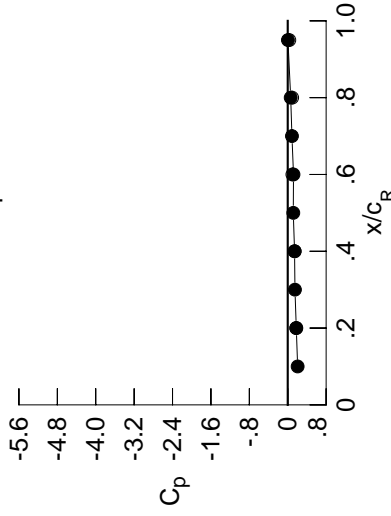

x/c_R	starb'd C_p	port C_p
0.10	0.2065	*****
0.20	0.1783	0.1768
0.30	0.1504	*****
0.40	0.1422	0.1452
0.50	0.1156	*****
0.60	0.1202	0.0971
0.70	0.0877	*****
0.80	0.0619	0.0921
0.90	0.0618	*****
0.95	0.0042	0.0327

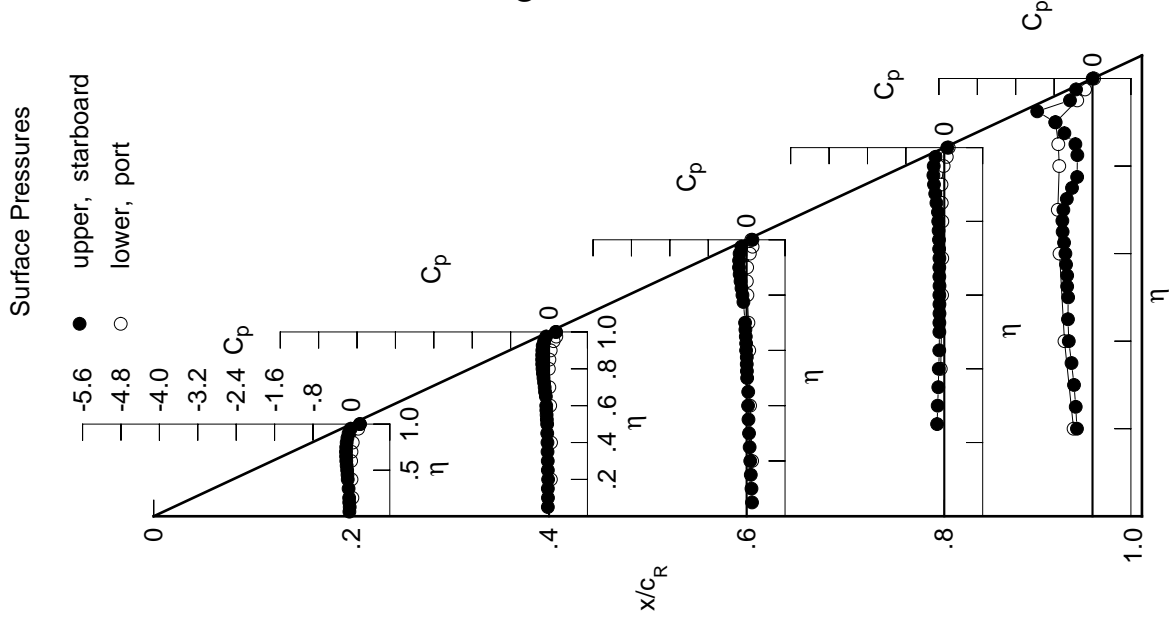
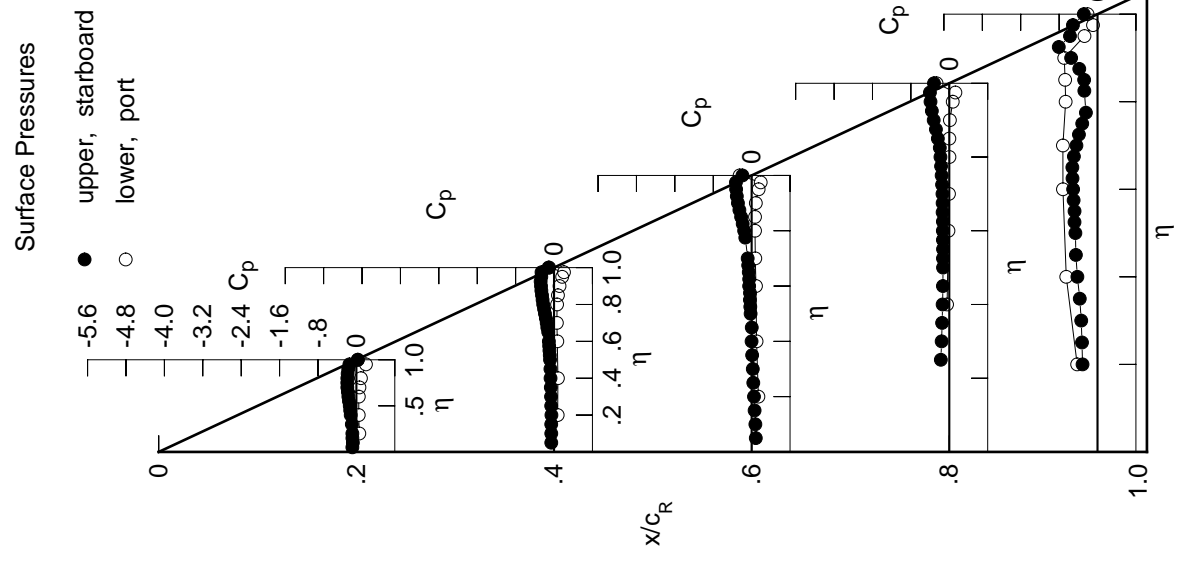

Table E3. Continued.

η	x/c_R .2	x/c_R .4	x/c_R .6	x/c_R .8	x/c_R .95
	$C_{p,u}$	$C_{p,u}$	$C_{p,u}$	$C_{p,u}$	$C_{p,u}$
0.050	-0.0838	-0.0578	0.0865	*****	*****
0.100	-0.0735	-0.0575	0.0778	*****	*****
0.150	-0.0836	-0.0587	0.0614	*****	*****
0.200	-0.0841	-0.0544	0.0491	*****	-0.3121
0.250	*****	-0.0589	0.0343	-0.1760	-0.3232
0.300	-0.0956	-0.0626	0.0241	-0.1595	-0.3388
0.350	*****	-0.0671	0.0107	-0.1498	-0.3697
0.400	-0.1187	-0.0729	-0.0016	-0.1391	-0.4195
0.450	-0.1289	-0.0753	0.0025	-0.1332	-0.4507
0.500	-0.1386	-0.0829	-0.0216	-0.1306	-0.4606
0.525	*****	-0.0885	-0.0278	-0.1320	-0.4793
0.550	-0.1546	-0.0963	-0.0362	-0.1303	-0.4786
0.575	*****	-0.1018	-0.0342	-0.1326	-0.4977
0.600	-0.1669	-0.1082	-0.0520	-0.1347	-0.5080
0.625	*****	*****	-0.0514	-0.1336	-0.5211
0.650	-0.1766	-0.1211	-0.0599	-0.1389	-0.5241
0.675	*****	-0.1399	-0.0721	-0.1391	-0.4920
0.700	-0.1889	-0.1530	-0.0825	-0.1421	-0.4392
0.725	*****	-0.1705	*****	-0.1506	-0.3873
0.750	-0.1896	-0.1885	*****	-0.1595	-0.3184
0.775	*****	-0.2069	-0.1316	-0.1708	-0.2416
0.800	-0.1884	-0.2252	-0.1557	-0.1837	*****
0.825	*****	-0.2383	-0.1862	-0.1975	-0.2742
0.850	-0.1825	-0.2504	-0.2194	-0.2381	-0.2782
0.875	*****	-0.2640	-0.2549	-0.2785	-0.3800
0.900	-0.1699	-0.2710	-0.2856	-0.3250	-0.5496
0.925	*****	-0.2794	-0.3084	-0.3634	-0.8069
0.950	-0.1457	-0.2660	-0.3230	-0.3915	-0.5734
0.975	*****	-0.2606	-0.3271	-0.4034	-0.5120
1.000	0.0283	-0.1153	-0.1921	-0.3196	-0.2856

η	$C_{p,l}$	$C_{p,l}$	$C_{p,l}$	$C_{p,l}$	$C_{p,l}$
-0.200	0.0605	0.0760	0.1404	*****	-0.4237
-0.400	0.0490	0.0807	0.1027	-0.0461	-0.6511
-0.600	0.0501	0.0684	0.0900	-0.0178	-0.7203
-0.700	0.0629	0.0589	0.0763	-0.0060	-0.7211
-0.800	0.0944	0.0634	0.0703	0.0030	-0.6641
-0.850	*****	0.0813	0.0703	0.0012	-0.6744
-0.900	*****	0.1147	0.0871	0.0131	-0.6936
-0.950	0.1991	0.1693	0.1457	0.0723	-0.2720
-0.975	*****	0.2074	0.1890	0.1270	-0.0933
-1.000	0.0314	-0.1015	-0.2506	-0.2648	-0.2070



Medium Radius L.E.
 Run No. = 11, Point No. = 223
 $C_N = 0.176$, $C_m = -0.0443$
 $\alpha = 4.0^\circ$, $M_\infty = 0.849$
 $R_{mac} = 24.1 \times 10^6$

Leading Edge Pressures

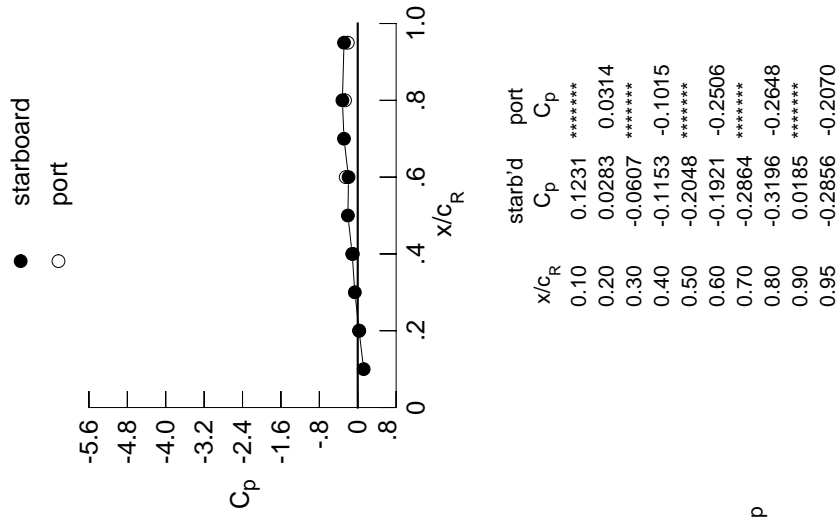

Table E3. Continued.

η	$x/c_R = .2$		$x/c_R = .4$		$x/c_R = .6$		$x/c_R = .8$		$x/c_R = .95$	
	$C_{p,u}$	$C_{p,u}$	$C_{p,u}$	$C_{p,u}$	$C_{p,u}$	$C_{p,u}$	$C_{p,u}$	$C_{p,u}$	$C_{p,u}$	$C_{p,u}$
0.050	-0.0978	-0.0723	0.0756	*****	*****	*****	*****	*****	*****	
0.100	-0.0901	-0.0733	0.0670	*****	*****	*****	*****	*****	*****	
0.150	-0.1011	-0.0764	0.0512	*****	*****	*****	*****	*****	*****	
0.200	-0.1018	-0.0695	0.0378	*****	*****	*****	*****	*****	-0.3149	
0.250	*****	-0.0758	0.0223	-0.1863	-0.1706	-0.3245	*****	*****	*****	
0.300	-0.1176	-0.0792	0.0135	-0.1706	-0.1615	-0.3453	*****	*****	*****	
0.350	*****	-0.0854	-0.0039	-0.1615	-0.1505	-0.3939	*****	*****	*****	
0.400	-0.1410	-0.0896	-0.0144	-0.1505	-0.1447	-0.4698	*****	*****	*****	
0.450	-0.1523	-0.0977	-0.0138	-0.1469	-0.1442	-0.4519	*****	*****	*****	
0.500	-0.1645	-0.1041	-0.0368	-0.1442	-0.1442	-0.4519	*****	*****	*****	
0.525	*****	-0.1118	-0.0450	-0.1447	-0.1447	-0.4698	*****	*****	*****	
0.550	-0.1810	-0.1190	-0.0513	-0.1442	-0.1442	-0.4687	*****	*****	*****	
0.575	*****	-0.1270	-0.0540	-0.1465	-0.1465	-0.4837	*****	*****	*****	
0.600	-0.1975	-0.1332	-0.0689	-0.1511	-0.1511	-0.4905	*****	*****	*****	
0.625	*****	*****	-0.0726	-0.1496	-0.1496	-0.5043	*****	*****	*****	
0.650	-0.2111	-0.1491	-0.0827	-0.1568	-0.1568	-0.5243	*****	*****	*****	
0.675	*****	-0.1700	-0.0962	-0.1606	-0.1606	-0.5266	*****	*****	*****	
0.700	-0.2259	-0.1851	-0.1054	-0.1624	-0.1624	-0.5306	*****	*****	*****	
0.725	*****	-0.2032	*****	-0.1730	-0.1730	-0.5169	*****	*****	*****	
0.750	-0.2320	-0.2254	*****	-0.1826	-0.1826	-0.4756	*****	*****	*****	
0.775	*****	-0.2463	-0.1634	-0.1982	-0.1982	-0.4224	*****	*****	*****	
0.800	-0.2352	-0.2710	-0.1932	-0.2151	*****	*****	*****	*****	*****	
0.825	*****	-0.2888	-0.2259	-0.2311	-0.4103	*****	*****	*****	*****	
0.850	-0.2353	-0.3087	-0.2667	-0.2736	-0.3435	*****	*****	*****	*****	
0.875	*****	-0.3282	-0.3102	-0.3246	-0.3329	*****	*****	*****	*****	
0.900	-0.2352	-0.3438	-0.3546	-0.3821	-0.3469	*****	*****	*****	*****	
0.925	*****	-0.3613	-0.3888	-0.4380	-0.3489	*****	*****	*****	*****	
0.950	-0.2197	-0.3633	-0.4255	-0.4868	-0.6290	*****	*****	*****	*****	
0.975	*****	-0.3809	-0.4550	-0.5352	-0.6099	*****	*****	*****	*****	
1.000	-0.0847	-0.3088	-0.4139	-0.6163	-0.5142	*****	*****	*****	*****	
-0.200	$C_{p,l}$	$C_{p,l}$	$C_{p,l}$	$C_{p,l}$	$C_{p,l}$	$C_{p,l}$	$C_{p,l}$	$C_{p,l}$	$C_{p,l}$	
-0.400	0.0825	0.0946	0.1529	*****	-0.4465	*****	*****	*****	*****	
-0.600	0.0716	0.0981	0.1178	-0.0330	-0.6767	*****	*****	*****	*****	
-0.700	0.0779	0.0919	0.1061	-0.0038	-0.7180	*****	*****	*****	*****	
-0.800	0.0927	0.0856	0.0977	0.0108	-0.7097	*****	*****	*****	*****	
-0.850	0.1252	0.0936	0.0962	0.0229	-0.6470	*****	*****	*****	*****	
-0.850	*****	0.1144	0.0994	0.0270	-0.6546	*****	*****	*****	*****	
-0.900	*****	0.1470	0.1217	0.0432	-0.6611	*****	*****	*****	*****	
-0.950	0.2196	0.1949	0.1734	0.1034	-0.2527	*****	*****	*****	*****	
-0.975	*****	0.2193	0.2056	0.1475	-0.0736	*****	*****	*****	*****	
-1.000	-0.0798	-0.2779	-0.5262	-0.5396	-0.4029	*****	*****	*****	*****	

Medium Radius L.E.
 Run No. = 11 , Point No. = 224
 $C_N = 0.217, C_m = -0.0502$
 $\alpha = 5.0^\circ, M_\infty = 0.849$
 $R_{mac} = 24.1 \times 10^6$

Leading Edge Pressures

● starboard
 ○ port

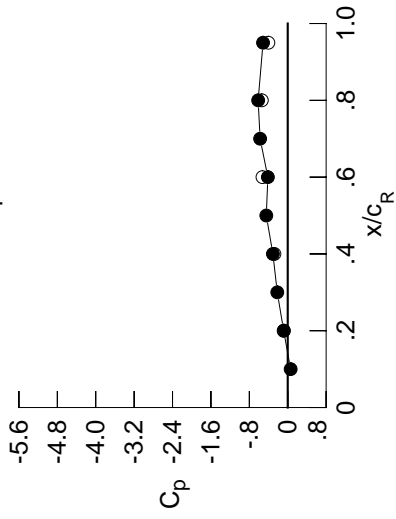

x/c_R	starb'd C_p	port C_p
0.10	0.0605	*****
0.20	-0.0847	-0.0798
0.30	-0.2180	*****
0.40	-0.3088	-0.2779
0.50	-0.4467	*****
0.60	-0.4139	-0.5262
0.70	-0.5754	*****
0.80	-0.6163	-0.5396
0.90	-0.0103	*****
0.95	-0.5142	-0.4029

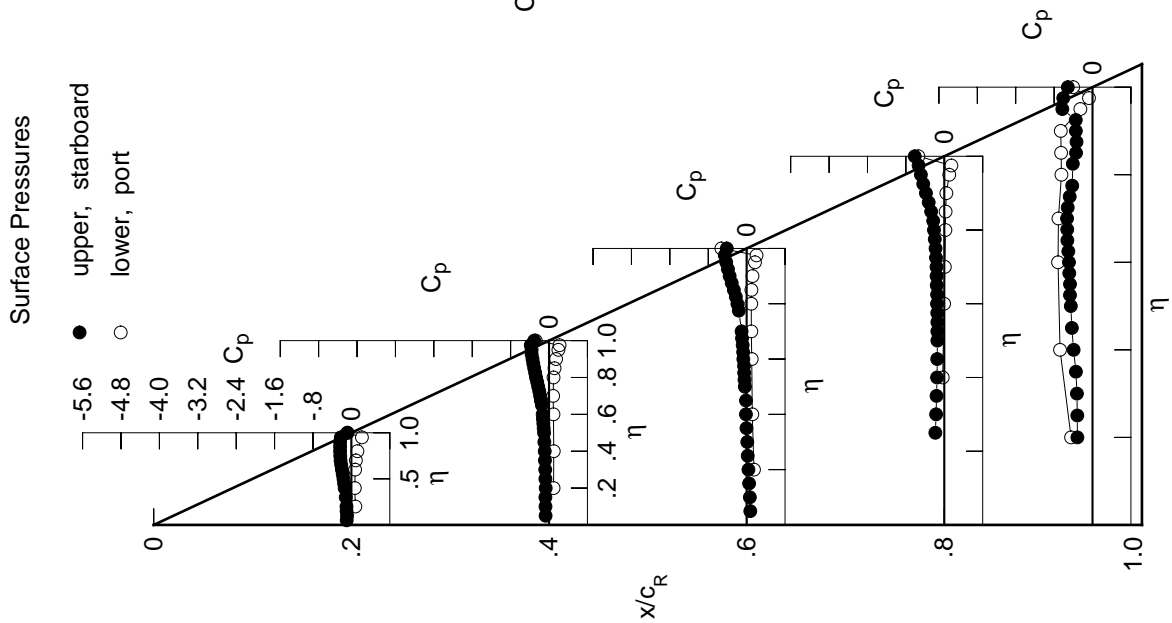

Table E3. Continued.

η	$x/c_R = .2$		$x/c_R = .4$		$x/c_R = .6$		$x/c_R = .8$		$x/c_R = .95$	
	$C_{p,u}$	$C_{p,u}$	$C_{p,u}$	$C_{p,u}$	$C_{p,u}$	$C_{p,u}$	$C_{p,u}$	$C_{p,u}$	$C_{p,u}$	$C_{p,u}$
0.050	-0.1163	-0.0881	0.0638	*****	*****	*****	*****	*****	*****	*****
0.100	-0.1099	-0.0909	0.0529	*****	*****	*****	*****	*****	*****	*****
0.150	-0.1198	-0.0912	0.0389	*****	*****	*****	*****	*****	*****	*****
0.200	-0.1237	-0.0874	0.0252	*****	*****	*****	*****	*****	*****	-0.3147
0.250	*****	-0.0934	0.0114	-0.1979	-0.3122	*****	*****	*****	*****	*****
0.300	-0.1370	-0.0984	-0.0021	-0.1824	-0.3128	*****	*****	*****	*****	*****
0.350	*****	-0.1044	-0.0182	-0.1737	-0.3304	*****	*****	*****	*****	*****
0.400	-0.1628	-0.1110	-0.0303	-0.1628	-0.3697	*****	*****	*****	*****	*****
0.450	-0.1770	-0.1175	-0.0276	-0.1601	-0.4068	*****	*****	*****	*****	*****
0.500	-0.1896	-0.1264	-0.0548	-0.1569	-0.4417	*****	*****	*****	*****	*****
0.525	*****	-0.1355	-0.0619	-0.1599	-0.4695	*****	*****	*****	*****	*****
0.550	-0.2104	-0.1430	-0.0695	-0.1583	-0.4802	*****	*****	*****	*****	*****
0.575	*****	-0.1524	-0.0717	-0.1636	-0.5031	*****	*****	*****	*****	*****
0.600	-0.2291	-0.1619	-0.0904	-0.1680	-0.5146	*****	*****	*****	*****	*****
0.625	*****	*****	-0.0940	-0.1682	-0.5394	*****	*****	*****	*****	*****
0.650	-0.2467	-0.1790	-0.1044	-0.1745	-0.5701	*****	*****	*****	*****	*****
0.675	*****	-0.2016	-0.1201	-0.1811	-0.5542	*****	*****	*****	*****	*****
0.700	-0.2657	-0.2165	-0.1335	-0.1857	-0.5326	*****	*****	*****	*****	*****
0.725	*****	-0.2397	*****	-0.1970	-0.5064	*****	*****	*****	*****	*****
0.750	-0.2762	-0.2647	*****	-0.2124	-0.4707	*****	*****	*****	*****	*****
0.775	*****	-0.2901	-0.1941	-0.2373	-0.4307	*****	*****	*****	*****	*****
0.800	-0.2862	-0.3187	-0.2300	-0.2549	*****	*****	*****	*****	*****	*****
0.825	*****	-0.3455	-0.2700	-0.2679	-0.3956	*****	*****	*****	*****	*****
0.850	-0.2932	-0.3708	-0.3170	-0.3147	-0.3171	*****	*****	*****	*****	*****
0.875	*****	-0.3961	-0.3672	-0.3679	-0.3087	*****	*****	*****	*****	*****
0.900	-0.3002	-0.4219	-0.4287	-0.4388	-0.3204	*****	*****	*****	*****	*****
0.925	*****	-0.4527	-0.4796	-0.5108	-0.3070	*****	*****	*****	*****	*****
0.950	-0.3050	-0.4643	-0.5377	-0.5839	-0.6441	*****	*****	*****	*****	*****
0.975	*****	-0.5189	-0.6086	-0.6707	-0.7191	*****	*****	*****	*****	*****
1.000	-0.2256	-0.5533	-0.6659	-0.9180	-0.7851	*****	*****	*****	*****	*****
-0.200	$C_{p,l}$	0.1007	0.1139	0.1683	*****	-0.4654	$C_{p,l}$	0.1007	0.1139	0.1683
-0.400	$C_{p,l}$	0.0956	0.1202	0.1335	-0.0201	-0.6933	$C_{p,l}$	0.0956	0.1202	0.1335
-0.600	$C_{p,l}$	0.1052	0.1135	0.1245	0.0131	-0.7135	$C_{p,l}$	0.1052	0.1135	0.1245
-0.700	$C_{p,l}$	0.1219	0.1104	0.1188	0.0255	-0.6972	$C_{p,l}$	0.1219	0.1104	0.1188
-0.800	$C_{p,l}$	0.1545	0.1230	0.1191	0.0435	-0.6340	$C_{p,l}$	0.1545	0.1230	0.1191
-0.850	$C_{p,l}$	*****	0.1450	0.1266	0.0504	-0.6370	$C_{p,l}$	*****	0.1450	0.1266
-0.900	$C_{p,l}$	*****	0.1759	0.1502	0.0710	-0.6338	$C_{p,l}$	*****	0.1759	0.1502
-0.950	$C_{p,l}$	0.2344	0.2146	0.1955	0.1278	-0.2368	$C_{p,l}$	0.2344	0.2146	0.1955
-0.975	$C_{p,l}$	*****	0.2196	0.2090	0.1590	-0.0634	$C_{p,l}$	*****	0.2196	0.2090
-1.000	$C_{p,l}$	-0.2221	-0.4924	-0.7990	-0.8487	-0.6655	$C_{p,l}$	-0.2221	-0.4924	-0.7990

Medium Radius L.E.
 Run No. = 11, Point No. = 225
 $C_N = 0.259$, $C_m = -0.0569$
 $\alpha = 6.1^\circ$, $M_\infty = 0.848$
 $R_{mac} = 24.0 \times 10^6$

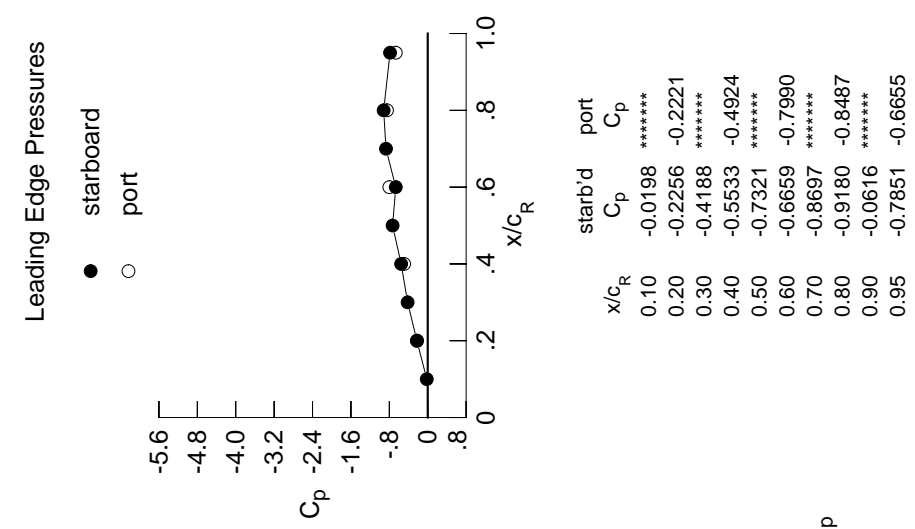
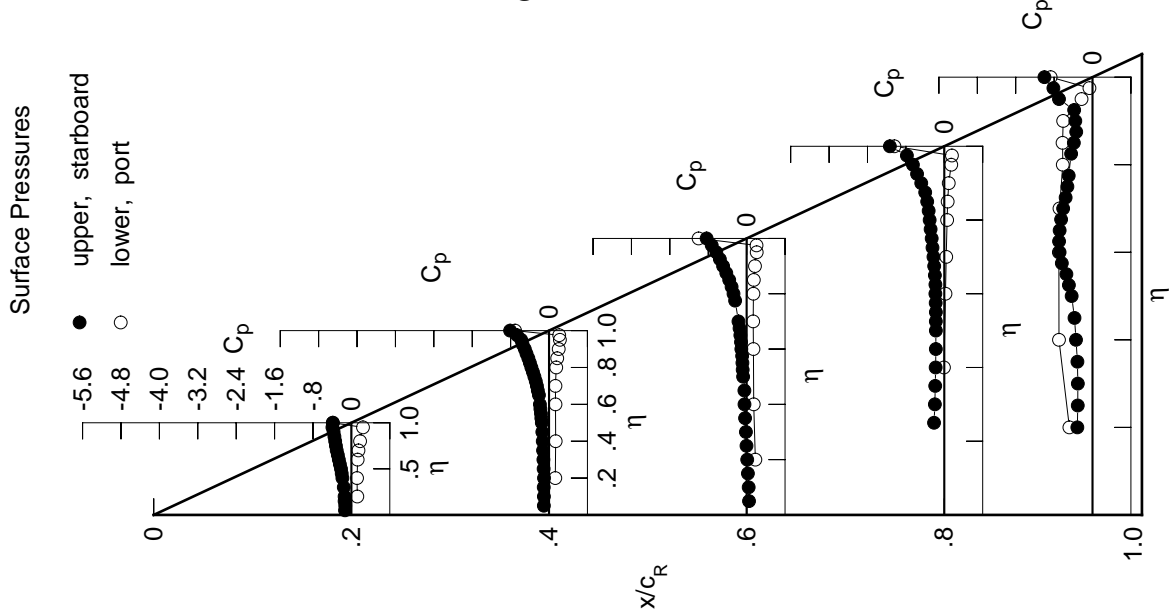

Table E3. Continued.

η	$x/c_R = .2$		$x/c_R = .4$		$x/c_R = .6$		$x/c_R = .8$		$x/c_R = .95$	
	$C_{p,u}$	$C_{p,u}$	$C_{p,u}$	$C_{p,u}$	$C_{p,u}$	$C_{p,u}$	$C_{p,u}$	$C_{p,u}$	$C_{p,u}$	$C_{p,u}$
0.050	-0.1329	-0.1084	0.0499	*****	*****	*****	*****	*****	*****	
0.100	-0.1281	-0.1070	0.0422	*****	*****	*****	*****	*****	*****	
0.150	-0.1418	-0.1101	0.0262	*****	*****	*****	*****	*****	*****	
0.200	-0.1413	-0.1049	0.0119	*****	*****	*****	*****	*****	-0.3156	
0.250	*****	-0.1126	-0.0035	-0.2133	-0.3074	*****	*****	*****	*****	
0.300	-0.1583	-0.1176	-0.0150	-0.1958	-0.3054	*****	*****	*****	*****	
0.350	*****	-0.1251	-0.0326	-0.1890	-0.3148	*****	*****	*****	*****	
0.400	-0.1868	-0.1315	-0.0448	-0.1796	-0.3437	*****	*****	*****	*****	
0.450	-0.2019	-0.1402	-0.0469	-0.1763	-0.3754	*****	*****	*****	*****	
0.500	-0.2169	-0.1503	-0.0739	-0.1753	-0.4346	*****	*****	*****	*****	
0.525	*****	-0.1608	-0.0826	-0.1764	-0.4917	*****	*****	*****	*****	
0.550	-0.2400	-0.1683	-0.0884	-0.1751	-0.5439	*****	*****	*****	*****	
0.575	-0.2620	-0.1796	-0.0935	-0.1793	-0.6390	*****	*****	*****	*****	
0.600	*****	-0.1107	-0.1855	-0.6857	*****	*****	*****	*****	*****	
0.625	*****	*****	-0.1176	-0.1849	-0.6968	*****	*****	*****	*****	
0.650	-0.2826	-0.2107	-0.1314	-0.1959	-0.6852	*****	*****	*****	*****	
0.675	*****	-0.2338	-0.1479	-0.2106	-0.6545	*****	*****	*****	*****	
0.700	-0.3055	-0.2528	-0.1704	-0.2256	-0.6123	*****	*****	*****	*****	
0.725	*****	-0.2761	*****	-0.2455	-0.5598	*****	*****	*****	*****	
0.750	-0.3220	-0.3047	*****	-0.2626	-0.5229	*****	*****	*****	*****	
0.775	*****	-0.3355	-0.2401	-0.2845	-0.4961	*****	*****	*****	*****	
0.800	-0.3375	-0.3681	-0.2737	-0.3051	*****	*****	*****	*****	*****	
0.825	*****	-0.3993	-0.3134	-0.3254	-0.4455	*****	*****	*****	*****	
0.850	-0.3537	-0.4313	-0.3634	-0.3556	-0.3892	*****	*****	*****	*****	
0.875	*****	-0.4696	-0.4243	-0.3980	-0.3391	*****	*****	*****	*****	
0.900	-0.3704	-0.5047	-0.4901	-0.4803	-0.3585	*****	*****	*****	*****	
0.925	*****	-0.5503	-0.5573	-0.5668	-0.3827	*****	*****	*****	*****	
0.950	-0.3949	-0.5796	-0.6319	-0.6536	-0.6987	*****	*****	*****	*****	
0.975	*****	-0.6660	-0.7272	-0.7794	-0.8155	*****	*****	*****	*****	
1.000	-0.3859	-0.8115	-0.8333	-1.1339	-1.0016	*****	*****	*****	*****	
-0.200	$C_{p,l}$	0.1229	0.1303	0.1815	*****	-0.4815	$C_{p,l}$	0.1229	0.1303	
-0.400	$C_{p,l}$	0.1178	0.1383	0.1475	0.0069	-0.6986	$C_{p,l}$	0.1178	0.1383	
-0.600	$C_{p,l}$	0.1302	0.1346	0.1413	0.0248	-0.7006	$C_{p,l}$	0.1302	0.1346	
-0.700	$C_{p,l}$	0.1474	0.1337	0.1364	0.0398	-0.6880	$C_{p,l}$	0.1474	0.1337	
-0.800	$C_{p,l}$	0.1807	0.1494	0.1412	0.0590	-0.6190	$C_{p,l}$	0.1807	0.1494	
-0.850	$C_{p,l}$	*****	0.1707	0.1494	0.0704	-0.6239	$C_{p,l}$	*****	0.1707	
-0.900	$C_{p,l}$	*****	0.2013	0.1734	0.0929	-0.6108	$C_{p,l}$	*****	0.2013	
-0.950	$C_{p,l}$	0.2418	0.2266	0.2093	0.1445	-0.2288	$C_{p,l}$	0.2418	0.2266	
-0.975	$C_{p,l}$	*****	0.2122	0.2057	0.1591	-0.0641	$C_{p,l}$	*****	0.2122	
-1.000	$C_{p,l}$	-0.3877	-0.7073	-1.0006	-1.0394	-0.8718	$C_{p,l}$	-0.3877	-0.7073	



Medium Radius L.E.
 Run No. = 11, Point No. = 226
 $C_N = 0.309$, $C_m = -0.0688$
 $\alpha = 7.1^\circ$, $M_\infty = 0.848$
 $R_{mac} = 24.0 \times 10^6$

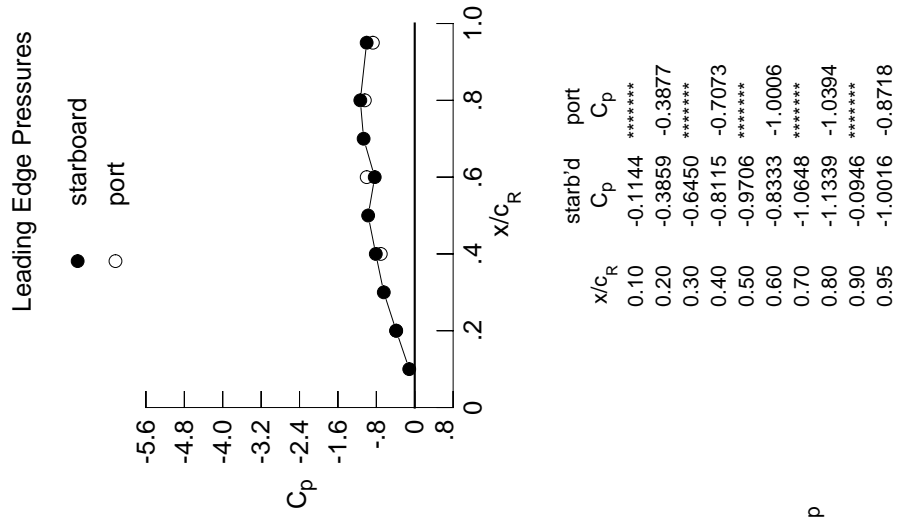
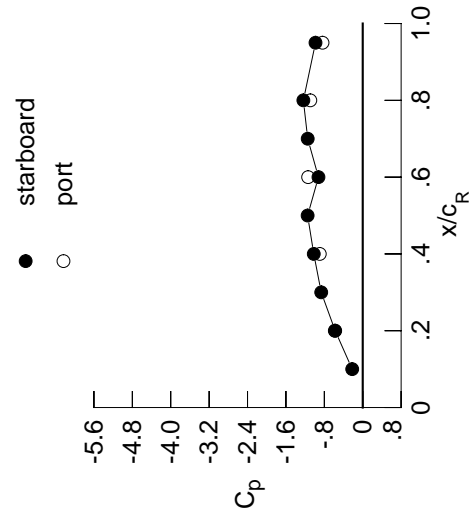

Table E3. Continued.

η	$x/c_R = .2$		$x/c_R = .4$		$x/c_R = .6$		$x/c_R = .8$		$x/c_R = .95$	
	$C_{p,u}$	$C_{p,u}$	$C_{p,u}$	$C_{p,u}$	$C_{p,u}$	$C_{p,u}$	$C_{p,u}$	$C_{p,u}$	$C_{p,u}$	$C_{p,u}$
0.050	-0.1485	-0.1231	0.0397	*****	*****	*****	*****	*****	*****	*****
0.100	-0.1458	-0.1229	0.0307	*****	*****	*****	*****	*****	*****	*****
0.150	-0.1575	-0.1282	0.0133	*****	*****	*****	*****	*****	*****	*****
0.200	-0.1593	-0.1195	0.0010	*****	*****	*****	*****	*****	*****	*****
0.250	*****	-0.1288	-0.0164	-0.2293	-0.2977	*****	*****	*****	*****	*****
0.300	-0.1763	-0.1330	-0.0286	-0.2147	-0.2849	*****	*****	*****	*****	*****
0.350	*****	-0.1432	-0.0488	-0.2039	-0.2916	*****	*****	*****	*****	*****
0.400	-0.2082	-0.1497	-0.0596	-0.1972	-0.3326	*****	*****	*****	*****	*****
0.450	-0.2238	-0.1605	-0.0606	-0.1897	-0.4263	*****	*****	*****	*****	*****
0.500	-0.2411	-0.1720	-0.0891	-0.1910	-0.5605	*****	*****	*****	*****	*****
0.525	*****	-0.1841	-0.0976	-0.1927	-0.6202	*****	*****	*****	*****	*****
0.550	-0.2686	-0.1932	-0.1073	-0.1951	-0.5948	*****	*****	*****	*****	*****
0.575	*****	-0.2072	-0.1120	-0.2058	-0.5693	*****	*****	*****	*****	*****
0.600	-0.2922	-0.2197	-0.1398	-0.2259	-0.5223	*****	*****	*****	*****	*****
0.625	*****	*****	-0.1492	-0.2390	-0.4958	*****	*****	*****	*****	*****
0.650	-0.3168	-0.2446	-0.1723	-0.2441	-0.4710	*****	*****	*****	*****	*****
0.675	*****	-0.2696	-0.1972	-0.2470	-0.4515	*****	*****	*****	*****	*****
0.700	-0.3450	-0.2867	-0.2147	-0.2702	-0.4622	*****	*****	*****	*****	*****
0.725	*****	-0.3138	*****	-0.2917	-0.4710	*****	*****	*****	*****	*****
0.750	-0.3687	-0.3419	*****	-0.2894	-0.4589	*****	*****	*****	*****	*****
0.775	*****	-0.3762	-0.2811	-0.2882	-0.4729	*****	*****	*****	*****	*****
0.800	-0.3917	-0.4159	-0.3030	-0.2974	*****	*****	*****	*****	*****	*****
0.825	*****	-0.4526	-0.3320	-0.3502	-0.5305	*****	*****	*****	*****	*****
0.850	-0.4166	-0.4933	-0.3801	-0.4493	-0.5016	*****	*****	*****	*****	*****
0.875	*****	-0.5400	-0.4427	-0.4348	-0.5979	*****	*****	*****	*****	*****
0.900	-0.4420	-0.5854	-0.5298	-0.4178	-0.7445	*****	*****	*****	*****	*****
0.925	*****	-0.6460	-0.7377	-0.6294	-0.7456	*****	*****	*****	*****	*****
0.950	-0.4930	-0.6912	-0.9535	-1.0044	-0.6246	*****	*****	*****	*****	*****
0.975	*****	-0.7860	-1.0525	-0.9037	-0.7176	*****	*****	*****	*****	*****
1.000	-0.5739	-1.0199	-0.9223	-1.2366	-0.9836	*****	*****	*****	*****	*****
-0.200	$C_{p,l}$	$C_{p,l}$	$C_{p,l}$	$C_{p,l}$	$C_{p,l}$	$C_{p,l}$	$C_{p,l}$	$C_{p,l}$	$C_{p,l}$	$C_{p,l}$
-0.400	0.1498	0.1535	0.2001	*****	-0.5062	*****	*****	*****	*****	*****
-0.600	0.1439	0.1616	0.1666	0.0100	-0.6977	*****	*****	*****	*****	*****
-0.700	0.1584	0.1582	0.1621	0.0428	-0.6950	*****	*****	*****	*****	*****
-0.800	0.1764	0.1604	0.1580	0.0607	-0.6720	*****	*****	*****	*****	*****
-0.850	0.2081	0.1779	0.1653	0.0814	-0.6032	*****	*****	*****	*****	*****
-0.900	*****	0.1990	0.1759	0.0928	-0.6015	*****	*****	*****	*****	*****
-0.950	0.2469	0.2384	0.2230	0.1157	-0.5842	*****	*****	*****	*****	*****
-0.975	0.2469	0.2026	0.2009	0.1628	-0.0512	*****	*****	*****	*****	*****
-1.000	-0.5812	-0.8944	-1.1376	-1.0921	-0.8374	*****	*****	*****	*****	*****

Medium Radius L.E.
 Run No. = 11, Point No. = 227
 $C_N = 0.359$, $C_m = -0.0788$
 $\alpha = 8.1^\circ$, $M_\infty = 0.849$
 $R_{mac} = 24.1 \times 10^6$

Leading Edge Pressures



x/c_R	starb'd C_p	port C_p
0.10	-0.2195	*****
0.20	-0.5739	-0.5812
0.30	-0.8649	*****
0.40	-1.0199	-0.8944
0.50	-1.1483	*****
0.60	-0.9223	-1.1376
0.70	-1.1461	*****
0.80	-1.2366	-1.0921
0.90	-0.1088	*****
0.95	-0.9836	-0.8374

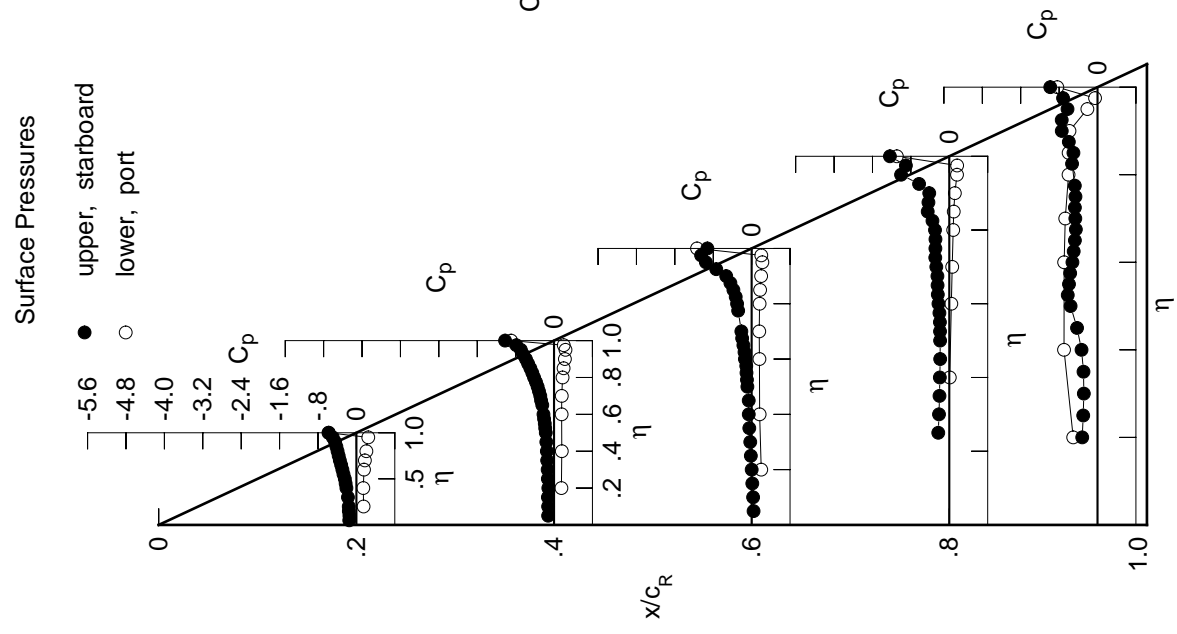
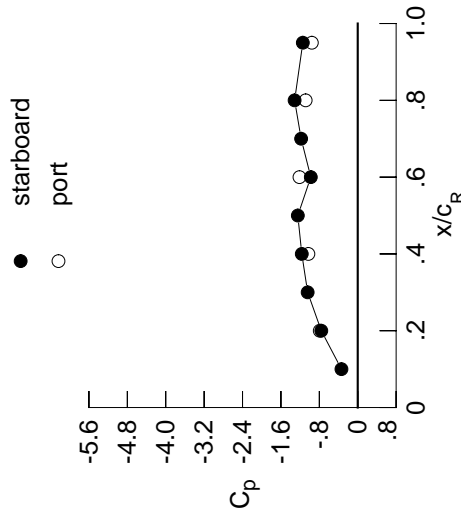

Table E3. Continued.

η	$x/c_R = .2$		$x/c_R = .4$		$x/c_R = .6$		$x/c_R = .8$		$x/c_R = .95$	
	$C_{p,u}$	$C_{p,l}$	$C_{p,u}$	$C_{p,l}$	$C_{p,u}$	$C_{p,l}$	$C_{p,u}$	$C_{p,l}$	$C_{p,u}$	$C_{p,l}$
0.050	-0.1619	-0.1393	0.0271	*****	*****	*****	*****	*****	*****	*****
0.100	-0.1604	-0.1397	0.0153	*****	*****	*****	*****	*****	*****	*****
0.150	-0.1744	-0.1450	0.0006	*****	*****	*****	*****	*****	*****	*****
0.200	-0.1771	-0.1381	-0.0153	*****	*****	*****	*****	*****	*****	*****
0.250	*****	-0.1472	-0.0309	-0.2438	-0.2285	-0.2370	*****	*****	*****	*****
0.300	-0.1975	-0.1526	-0.0439	-0.2285	-0.2198	-0.2760	*****	*****	*****	*****
0.350	*****	-0.1629	-0.0601	-0.2198	-0.2076	-0.3710	*****	*****	*****	*****
0.400	-0.2303	-0.1694	-0.0727	-0.2076	-0.3710	*****	*****	*****	*****	*****
0.450	-0.2460	-0.1832	-0.0725	-0.2087	-0.4374	*****	*****	*****	*****	*****
0.500	-0.2655	-0.1968	-0.1089	-0.2255	-0.4535	*****	*****	*****	*****	*****
0.525	*****	-0.2147	-0.1288	-0.2339	-0.4561	*****	*****	*****	*****	*****
0.550	-0.2939	-0.2253	-0.1473	-0.2441	-0.4389	*****	*****	*****	*****	*****
0.575	*****	-0.2416	-0.1645	-0.2551	-0.4371	*****	*****	*****	*****	*****
0.600	-0.3212	-0.2590	-0.1937	-0.2603	-0.4378	*****	*****	*****	*****	*****
0.625	*****	*****	-0.2031	-0.2580	-0.4479	*****	*****	*****	*****	*****
0.650	-0.3507	-0.2875	-0.2103	-0.2572	-0.4475	*****	*****	*****	*****	*****
0.675	*****	-0.3065	-0.2108	-0.2688	-0.4352	*****	*****	*****	*****	*****
0.700	-0.3844	-0.3254	-0.2138	-0.2975	-0.4496	*****	*****	*****	*****	*****
0.725	*****	-0.3501	*****	-0.3416	-0.4668	*****	*****	*****	*****	*****
0.750	-0.4138	-0.3807	*****	-0.3441	-0.4620	*****	*****	*****	*****	*****
0.775	*****	-0.4145	-0.3241	-0.3565	-0.4539	*****	*****	*****	*****	*****
0.800	-0.4446	-0.4536	-0.3605	-0.3707	*****	*****	*****	*****	*****	*****
0.825	*****	-0.4918	-0.3628	-0.4252	-0.4744	*****	*****	*****	*****	*****
0.850	-0.4798	-0.5372	-0.3434	-0.5771	-0.4505	*****	*****	*****	*****	*****
0.875	*****	-0.5889	-0.4206	-0.4902	-0.4536	*****	*****	*****	*****	*****
0.900	-0.5205	-0.6477	-0.9327	-0.4519	-0.7701	*****	*****	*****	*****	*****
0.925	*****	-0.7552	-1.0813	-0.7054	-0.8104	*****	*****	*****	*****	*****
0.950	-0.5985	-0.9467	-1.0934	-1.1547	-0.6608	*****	*****	*****	*****	*****
0.975	*****	-1.1626	-1.0551	-0.9163	-0.9794	*****	*****	*****	*****	*****
1.000	-0.7594	-1.1653	-0.9776	-1.3149	-1.1440	*****	*****	*****	*****	*****
-0.200	$C_{p,l}$	0.1749	0.1755	0.2167	*****	-0.5437	*****	*****	*****	*****
-0.400		0.1707	0.1861	0.1841	0.0252	-0.7047	*****	*****	*****	*****
-0.600		0.1872	0.1821	0.1804	0.0606	-0.6866	*****	*****	*****	*****
-0.700		0.2057	0.1874	0.1793	0.0763	-0.6650	*****	*****	*****	*****
-0.800		0.2362	0.2059	0.1880	0.1000	-0.5909	*****	*****	*****	*****
-0.850	*****	0.2269	0.1987	0.1111	-0.5897	*****	*****	*****	*****	*****
-0.900	*****	0.2488	0.2180	0.1360	-0.5705	*****	*****	*****	*****	*****
-0.950	0.2503	0.2471	0.2319	0.1739	-0.2108	*****	*****	*****	*****	*****
-0.975	*****	0.1911	0.1953	0.1630	-0.0652	*****	*****	*****	*****	*****
-1.000	-0.7909	-1.0278	-1.2137	-1.0846	-0.9558	*****	*****	*****	*****	*****

Medium Radius L.E.
 Run No. = 11, Point No. = 228
 $C_N = 0.407$, $C_m = -0.0885$
 $\alpha = 9.1^\circ$, $M_\infty = 0.848$
 $R_{mac} = 24.1 \times 10^6$

Leading Edge Pressures



x/c_R	starb'd C_p	port C_p
0.10	-0.3390	*****
0.20	-0.7594	-0.7909
0.30	-1.0430	*****
0.40	-1.1653	-1.0278
0.50	-1.2480	*****
0.60	-0.9776	-1.2137
0.70	-1.1789	*****
0.80	-1.3149	-1.0846
0.90	-0.1179	*****
0.95	-1.1440	-0.9558

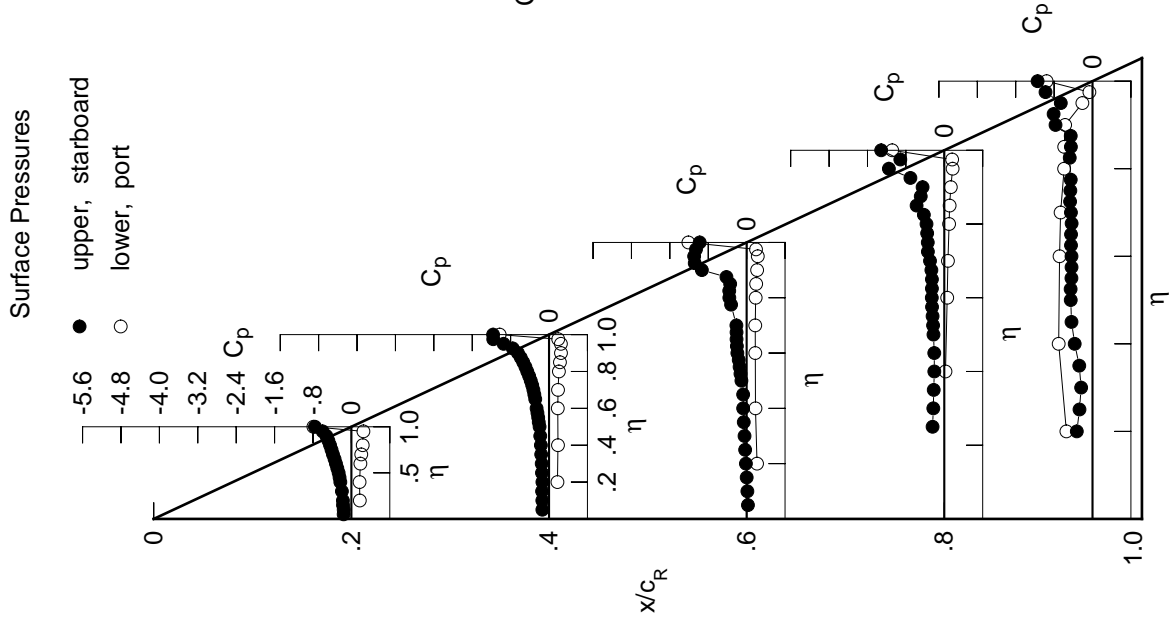
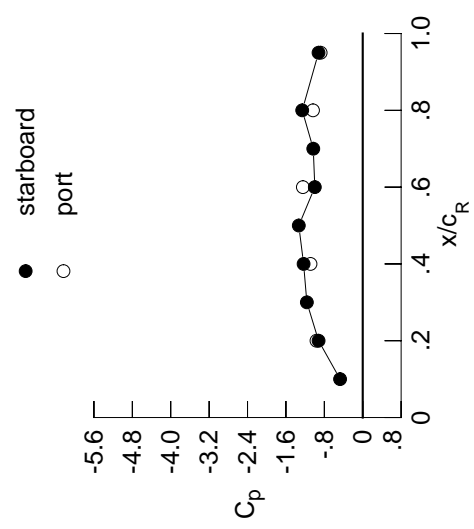

Table E3. Continued.

η	$x/c_R = .2$		$x/c_R = .4$		$x/c_R = .6$		$x/c_R = .8$		$x/c_R = .95$	
	$C_{p,u}$	$C_{p,u}$	$C_{p,u}$	$C_{p,u}$	$C_{p,u}$	$C_{p,u}$	$C_{p,u}$	$C_{p,u}$	$C_{p,u}$	$C_{p,u}$
0.050	-0.1781	-0.1617	0.0043	*****	*****	*****	*****	*****	*****	*****
0.100	-0.1776	-0.1623	-0.0068	*****	*****	*****	*****	*****	*****	*****
0.150	-0.1965	-0.1689	-0.0257	*****	*****	*****	*****	*****	*****	*****
0.200	-0.1989	-0.1623	-0.0394	*****	*****	*****	*****	*****	*****	-0.2943
0.250	*****	-0.1732	-0.0572	-0.2717	-0.2337	*****	*****	*****	*****	-0.2337
0.300	-0.2183	-0.1771	-0.0670	-0.2543	-0.2631	*****	*****	*****	*****	-0.2631
0.350	*****	-0.1880	-0.0855	-0.2425	-0.3387	*****	*****	*****	*****	-0.3387
0.400	-0.2517	-0.1920	-0.1027	-0.2387	-0.4147	*****	*****	*****	*****	-0.4147
0.450	-0.2724	-0.2129	-0.1248	-0.2516	-0.4299	*****	*****	*****	*****	-0.4299
0.500	-0.2929	-0.2411	-0.1717	-0.2628	-0.4230	*****	*****	*****	*****	-0.4230
0.525	*****	-0.2590	-0.1739	-0.2581	-0.4262	*****	*****	*****	*****	-0.4262
0.550	-0.3248	-0.2714	-0.1789	-0.2597	-0.4157	*****	*****	*****	*****	-0.4157
0.575	*****	-0.2880	-0.1911	-0.2660	-0.4298	*****	*****	*****	*****	-0.4298
0.600	-0.3548	-0.2978	-0.2356	-0.2728	-0.4331	*****	*****	*****	*****	-0.4331
0.625	*****	*****	-0.2456	-0.2660	-0.4450	*****	*****	*****	*****	-0.4450
0.650	-0.3839	-0.3196	-0.2451	-0.2636	-0.4539	*****	*****	*****	*****	-0.4539
0.675	*****	-0.3429	-0.2537	-0.2641	-0.4479	*****	*****	*****	*****	-0.4479
0.700	-0.4267	-0.3536	-0.2617	-0.2685	-0.4916	*****	*****	*****	*****	-0.4916
0.725	*****	-0.3768	*****	-0.2945	-0.5948	*****	*****	*****	*****	-0.5948
0.750	-0.4615	-0.3959	*****	-0.3801	-0.6830	*****	*****	*****	*****	-0.6830
0.775	*****	-0.4203	-0.3965	-0.6376	-0.6781	*****	*****	*****	*****	-0.6781
0.800	-0.4995	-0.4481	-0.4443	-0.8423	*****	*****	*****	*****	*****	-0.8423
0.825	*****	-0.4780	-0.4852	-0.9073	-0.5421	*****	*****	*****	*****	-0.5421
0.850	-0.5521	-0.6438	-0.5039	-0.8068	-0.4992	*****	*****	*****	*****	-0.4992
0.875	*****	-0.8569	-0.8871	-0.6868	-0.5205	*****	*****	*****	*****	-0.5205
0.900	-0.6068	-1.0253	-1.0873	-0.6573	-0.6156	*****	*****	*****	*****	-0.6156
0.925	*****	-1.1469	-1.1004	-0.7275	-0.7303	*****	*****	*****	*****	-0.7303
0.950	-0.7048	-1.1472	-1.0769	-0.9156	-0.6704	*****	*****	*****	*****	-0.6704
0.975	*****	-1.1183	-1.0344	-0.7309	-0.7376	*****	*****	*****	*****	-0.7376
1.000	-0.9199	-1.2318	-0.9983	-1.2604	-0.9208	*****	*****	*****	*****	-0.9208
-0.200	$C_{p,l}$	$C_{p,l}$	$C_{p,l}$	$C_{p,l}$	$C_{p,l}$	$C_{p,l}$	$C_{p,l}$	$C_{p,l}$	$C_{p,l}$	$C_{p,l}$
-0.400	0.1979	0.1986	0.2339	*****	*****	*****	*****	*****	*****	-0.5665
-0.600	0.1967	0.2065	0.2034	0.0386	0.6950	*****	*****	*****	*****	-0.6950
-0.700	0.2150	0.2080	0.1982	0.0751	-0.6744	*****	*****	*****	*****	-0.6744
-0.800	0.2329	0.2116	0.1992	0.0911	-0.6508	*****	*****	*****	*****	-0.6508
-0.850	0.2605	0.2312	0.2086	0.1163	-0.5776	*****	*****	*****	*****	-0.5776
-0.900	*****	0.2494	0.2193	0.1274	-0.5714	*****	*****	*****	*****	-0.5714
-0.950	*****	0.2666	0.2365	0.1524	-0.5438	*****	*****	*****	*****	-0.5438
-0.975	0.2481	0.2521	0.2392	0.1819	-0.1961	*****	*****	*****	*****	-0.1961
-1.000	*****	0.1806	0.1865	0.1561	-0.0553	*****	*****	*****	*****	-0.0553
-1.000	-0.9629	-1.0877	-1.2470	-1.0364	-0.8766	*****	*****	*****	*****	-0.8766

Medium Radius L.E.
 Run No. = 11, Point No. = 229
 $C_N = 0.468$, $C_m = -0.0998$
 $\alpha = 10.2^\circ$, $M_\infty = 0.849$
 $R_{mac} = 24.0 \times 10^6$

Leading Edge Pressures



x/c_R	starb'd C_p	port C_p
0.10	-0.4716	*****
0.20	-0.9199	-0.9629
0.30	-1.1642	*****
0.40	-1.2318	-1.0877
0.50	-1.3317	*****
0.60	-0.9983	-1.2470
0.70	-1.0304	*****
0.80	-1.2604	-1.0364
0.90	-0.1175	*****
0.95	-0.9208	-0.8766

Surface Pressures

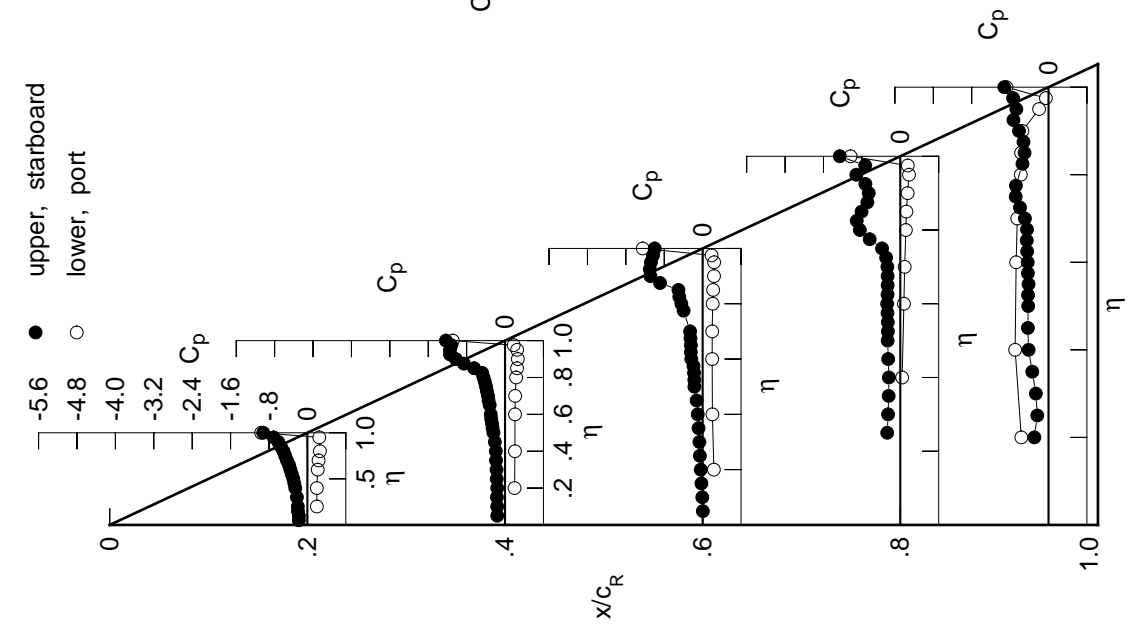
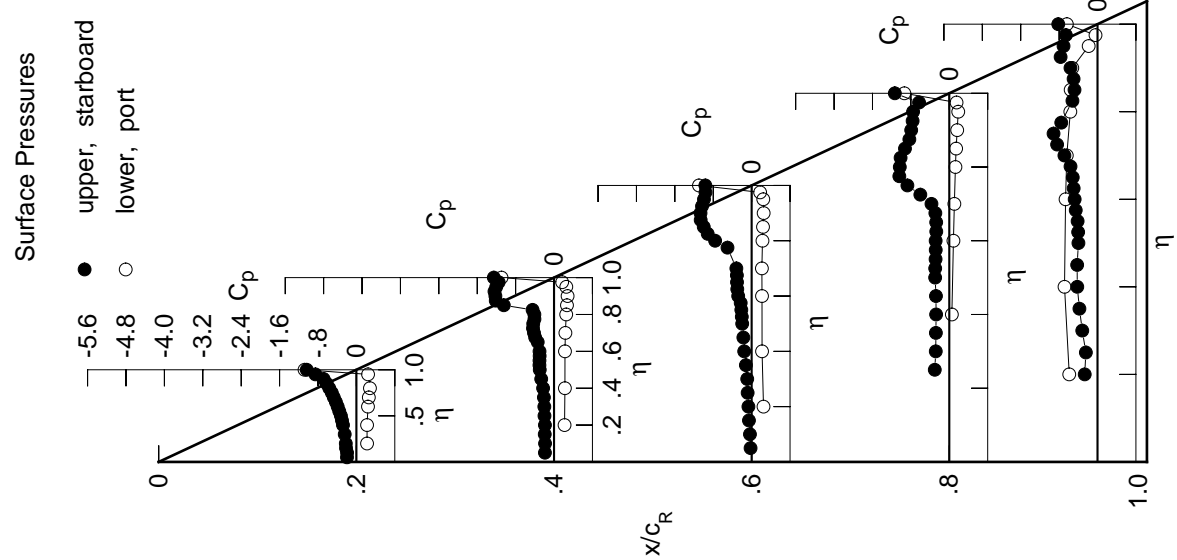
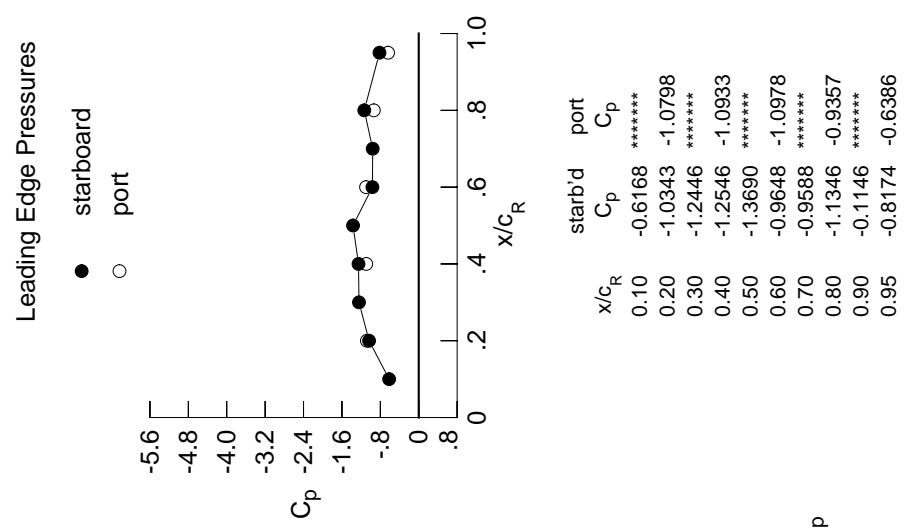

Table E3. Continued.

η	$x/c_R = .2$		$x/c_R = .4$		$x/c_R = .6$		$x/c_R = .8$		$x/c_R = .95$	
	$C_{p,u}$	$C_{p,u}$	$C_{p,u}$	$C_{p,u}$	$C_{p,u}$	$C_{p,u}$	$C_{p,u}$	$C_{p,u}$	$C_{p,u}$	$C_{p,u}$
0.050	-0.1961	-0.1893	-0.0221	*****	*****	*****	*****	*****	*****	*****
0.100	-0.1942	-0.1872	-0.0356	*****	*****	*****	*****	*****	*****	*****
0.150	-0.2158	-0.1936	-0.0556	*****	*****	*****	*****	*****	*****	*****
0.200	-0.2207	-0.1898	-0.0674	*****	*****	*****	*****	*****	*****	-0.2666
0.250	*****	-0.1991	-0.0830	-0.3022	-0.2817	-0.3172	*****	*****	*****	-0.2425
0.300	-0.2434	-0.2026	-0.0920	-0.2817	-0.2792	-0.3764	*****	*****	*****	-0.3172
0.350	*****	-0.2116	-0.1201	-0.2792	-0.2748	-0.4216	*****	*****	*****	-0.3764
0.400	-0.2793	-0.2281	-0.1552	-0.2748	-0.2711	-0.4216	*****	*****	*****	-0.4216
0.450	-0.3003	-0.2673	-0.1729	-0.2779	-0.2942	-0.4243	*****	*****	*****	-0.4243
0.500	-0.3223	-0.2974	-0.1971	-0.2942	-0.2934	-0.3976	*****	*****	*****	-0.3976
0.525	*****	-0.3041	-0.2051	-0.2934	-0.4034	*****	*****	*****	*****	-0.4034
0.550	-0.3565	-0.3034	-0.2150	-0.2859	-0.4141	*****	*****	*****	*****	-0.4141
0.575	*****	-0.3003	-0.2278	-0.2825	-0.4539	*****	*****	*****	*****	-0.4539
0.600	-0.3895	-0.3026	-0.2800	-0.2836	-0.4763	*****	*****	*****	*****	-0.4763
0.625	*****	*****	-0.2990	-0.2711	-0.4966	*****	*****	*****	*****	-0.4966
0.650	-0.4270	-0.3401	-0.3052	-0.2726	-0.5156	*****	*****	*****	*****	-0.5156
0.675	*****	-0.3931	-0.3074	-0.2904	-0.5621	*****	*****	*****	*****	-0.5621
0.700	-0.4701	-0.4179	-0.3187	-0.3716	-0.6897	*****	*****	*****	*****	-0.6897
0.725	*****	-0.4381	*****	-0.6030	-0.8420	*****	*****	*****	*****	-0.8420
0.750	-0.5116	-0.4335	*****	-0.8731	-0.9159	*****	*****	*****	*****	-0.9159
0.775	*****	-0.4083	-0.5029	-1.0412	-0.7550	*****	*****	*****	*****	-0.7550
0.800	-0.5646	-0.4096	-0.7606	-1.0315	*****	*****	*****	*****	*****	-1.0315
0.825	*****	-0.4471	-0.9155	-1.0144	-0.5225	*****	*****	*****	*****	-0.5225
0.850	-0.6179	-1.0465	-0.9979	-0.9235	-0.4793	*****	*****	*****	*****	-0.4793
0.875	*****	-1.2144	-1.0617	-0.8321	-0.4982	*****	*****	*****	*****	-0.4982
0.900	-0.6821	-1.2218	-1.0649	-0.7939	-0.5634	*****	*****	*****	*****	-0.5634
0.925	*****	-1.2406	-1.0335	-0.7642	-0.7690	*****	*****	*****	*****	-0.7690
0.950	-0.8535	-1.2042	-0.9929	-0.7548	-0.7084	*****	*****	*****	*****	-0.7084
0.975	*****	-1.1533	-0.9616	-0.6298	-0.6590	*****	*****	*****	*****	-0.6590
1.000	-1.0343	-1.2546	-0.9648	-1.1346	-0.8174	*****	*****	*****	*****	-0.8174
-0.200	$C_{p,l}$	$C_{p,l}$	$C_{p,l}$	$C_{p,l}$	$C_{p,l}$	$C_{p,l}$	$C_{p,l}$	$C_{p,l}$	$C_{p,l}$	$C_{p,l}$
-0.400	0.2221	0.2191	0.2471	*****	-0.5886	*****	*****	*****	*****	-0.5886
-0.600	0.2226	0.2268	0.2171	0.0537	-0.6872	*****	*****	*****	*****	-0.6872
-0.700	0.2419	0.2279	0.2158	0.0862	-0.6656	*****	*****	*****	*****	-0.6656
-0.800	0.2594	0.2364	0.2133	0.1056	-0.6402	*****	*****	*****	*****	-0.6402
-0.850	0.2825	0.2539	0.2256	0.1278	-0.5661	*****	*****	*****	*****	-0.5661
-0.900	*****	0.2695	0.2366	0.1421	-0.5592	*****	*****	*****	*****	-0.5592
-0.950	*****	0.2825	0.2505	0.1646	-0.5253	*****	*****	*****	*****	-0.5253
-0.975	0.2435	0.2555	0.2427	0.1867	-0.1837	*****	*****	*****	*****	-0.1837
-1.000	*****	0.1691	0.1770	0.1511	-0.0418	*****	*****	*****	*****	-0.0418
-1.000	-1.0798	-1.0933	-1.0978	-0.9357	-0.6386	*****	*****	*****	*****	-0.6386

Medium Radius L.E.
 Run No. = 11, Point No. = 230
 $C_N = 0.532$, $C_m = -0.1140$
 $\alpha = 11.2^\circ$, $M_\infty = 0.850$
 $R_{mac} = 24.0 \times 10^6$



x/c_R	starb'd C_p	port C_p
0.10	-0.6168	*****
0.20	-1.0343	-1.0798
0.30	-1.2446	*****
0.40	-1.2546	-1.0933
0.50	-1.3690	*****
0.60	-0.9648	-1.0978
0.70	-0.9588	*****
0.80	-1.1346	-0.9357
0.90	-0.1146	*****
0.95	-0.8174	-0.6386

Table E3. Continued.

η	x/c_R .2	x/c_R .4	x/c_R .6	x/c_R .8	x/c_R .95
	$C_{p,u}$	$C_{p,u}$	$C_{p,u}$	$C_{p,u}$	$C_{p,u}$
0.050	-0.2105	-0.2175	-0.0427	*****	*****
0.100	-0.2039	-0.2185	-0.0559	*****	*****
0.150	-0.2337	-0.2221	-0.0757	*****	*****
0.200	-0.2426	-0.2211	-0.0858	*****	-0.2550
0.250	*****	-0.2248	-0.1001	-0.3254	-0.2748
0.300	-0.2689	-0.2246	-0.1196	-0.3088	-0.3553
0.350	*****	-0.2499	-0.1551	-0.3102	-0.3886
0.400	-0.3054	-0.2819	-0.1822	-0.3026	-0.3964
0.450	-0.3297	-0.3081	-0.2044	-0.2890	-0.4056
0.500	-0.3535	-0.3318	-0.2285	-0.2798	-0.4863
0.525	*****	-0.3381	-0.2330	-0.2746	-0.5457
0.550	-0.3882	-0.3390	-0.2346	-0.2692	-0.5662
0.575	*****	-0.3405	-0.2322	-0.2722	-0.5964
0.600	-0.4213	-0.3461	-0.2589	-0.2870	-0.6127
0.625	*****	*****	-0.2574	-0.3233	-0.6734
0.650	-0.4641	-0.3937	-0.3037	-0.4347	-0.7869
0.675	*****	-0.4578	-0.3938	-0.6301	-0.9172
0.700	-0.5116	-0.4817	-0.5407	-0.8626	-1.0425
0.725	*****	-0.4846	*****	-1.0465	-1.0867
0.750	-0.5628	-0.4972	*****	-1.1155	-0.8543
0.775	*****	-0.4628	-0.9398	-1.1043	-0.6869
0.800	-0.6083	-0.4303	-0.9602	-1.0177	*****
0.825	*****	-0.6648	-0.9764	-0.9681	-0.5277
0.850	-0.6810	-1.2993	-0.9956	-0.8883	-0.4790
0.875	*****	-1.3569	-1.0366	-0.8373	-0.4773
0.900	-0.9007	-1.3292	-1.0209	-0.8003	-0.5128
0.925	*****	-1.3174	-0.9656	-0.7576	-0.6605
0.950	-1.1706	-1.2889	-0.9157	-0.7201	-0.5893
0.975	*****	-1.2427	-0.8831	-0.6175	-0.4929
1.000	-1.1279	-1.3060	-0.8986	-1.0519	-0.6332
	$C_{p,l}$	$C_{p,l}$	$C_{p,l}$	$C_{p,l}$	$C_{p,l}$
-0.200	0.2540	0.2460	0.2695	*****	-0.5791
-0.400	0.2536	0.2547	0.2395	0.0713	-0.6794
-0.600	0.2735	0.2556	0.2381	0.1048	-0.6541
-0.700	0.2893	0.2639	0.2353	0.1228	-0.6295
-0.800	0.3101	0.2815	0.2486	0.1455	-0.5534
-0.850	*****	0.2951	0.2585	0.1582	-0.5448
-0.900	*****	0.3008	0.2686	0.1790	-0.5076
-0.950	0.2444	0.2619	0.2503	0.1918	-0.1763
-0.975	*****	0.1588	0.1723	0.1444	-0.0442
-1.000	-1.1434	-1.0881	-1.0151	-0.9075	-0.6227

Medium Radius L.E.
 Run No. = 11, Point No. = 231
 $C_N = 0.591$, $C_m = -0.1249$
 $\alpha = 12.2^\circ$, $M_\infty = 0.849$
 $R_{mac} = 23.9 \times 10^6$

Leading Edge Pressures

● starboard
 ○ port

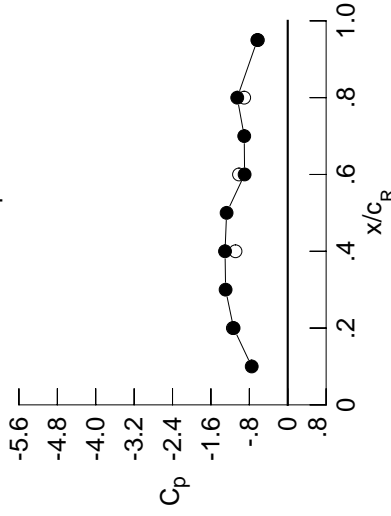

x/c_R	starb'd C_p	port C_p
0.10	-0.7503	*****
0.20	-1.1279	-1.1434
0.30	-1.2943	*****
0.40	-1.3060	-1.0881
0.50	-1.2737	*****
0.60	-0.8986	-1.0151
0.70	-0.9063	*****
0.80	-1.0519	-0.9075
0.90	-0.1011	*****
0.95	-0.6332	-0.6227

Surface Pressures

● upper, starboard
 ○ lower, port

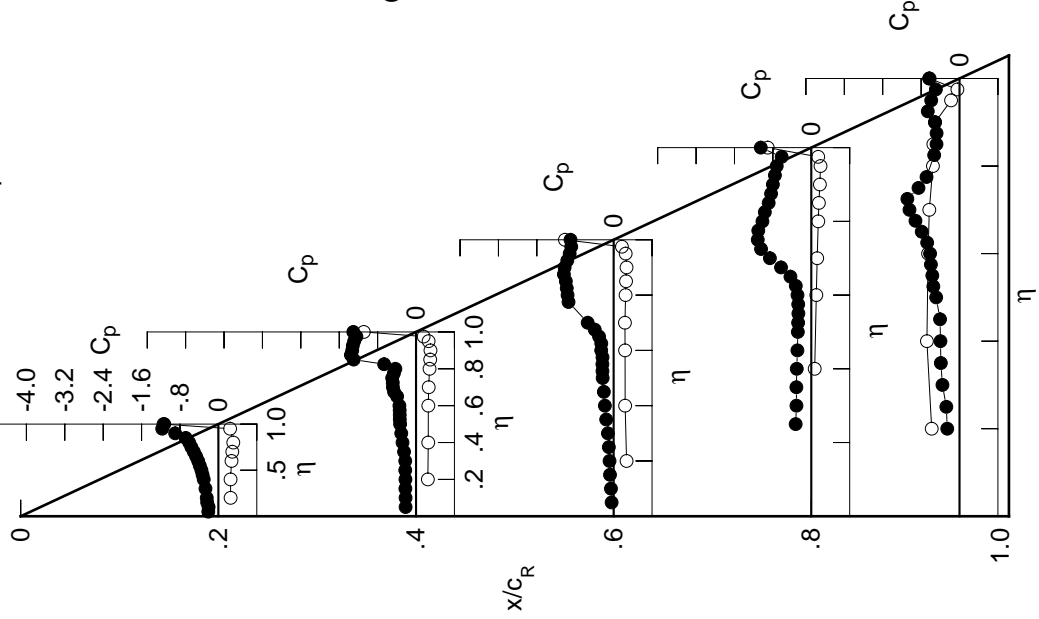
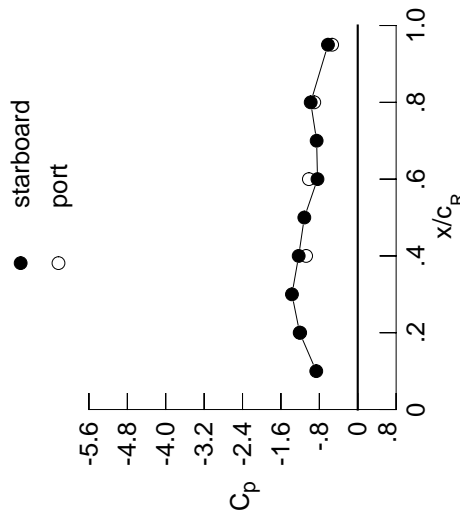

Table E3. Continued.

η	$x/c_R = .2$		$x/c_R = .4$		$x/c_R = .6$		$x/c_R = .8$		$x/c_R = .95$	
	$C_{p,u}$	$C_{p,u}$	$C_{p,u}$	$C_{p,u}$	$C_{p,u}$	$C_{p,u}$	$C_{p,u}$	$C_{p,u}$	$C_{p,u}$	$C_{p,u}$
0.050	-0.2336	-0.2527	-0.0653	*****	*****	*****	*****	*****	*****	*****
0.100	-0.2209	-0.2521	-0.0762	*****	*****	*****	*****	*****	*****	*****
0.150	-0.2551	-0.2548	-0.0988	*****	*****	*****	*****	*****	*****	*****
0.200	-0.2688	-0.2538	-0.1066	*****	*****	*****	*****	*****	*****	*****
0.250	*****	-0.2551	-0.1273	-0.3500	-0.3382	*****	*****	*****	*****	-0.3290
0.300	-0.2992	-0.2720	-0.1518	-0.3409	-0.3766	*****	*****	*****	*****	*****
0.350	*****	-0.3111	-0.1954	-0.3345	-0.3662	*****	*****	*****	*****	*****
0.400	-0.3439	-0.3188	-0.2051	-0.3143	-0.3781	*****	*****	*****	*****	*****
0.450	-0.3628	-0.3326	-0.1940	-0.3004	-0.4569	*****	*****	*****	*****	*****
0.500	-0.3831	-0.3748	-0.2049	-0.2896	-0.5676	*****	*****	*****	*****	*****
0.525	*****	-0.3802	-0.2074	-0.2878	-0.6132	*****	*****	*****	*****	*****
0.550	-0.4173	-0.3763	-0.2094	-0.2881	-0.6219	*****	*****	*****	*****	*****
0.575	*****	-0.3765	-0.2031	-0.3063	-0.6579	*****	*****	*****	*****	*****
0.600	-0.4495	-0.3802	-0.2416	-0.3522	-0.7058	*****	*****	*****	*****	*****
0.625	*****	*****	-0.2864	-0.4531	-0.8062	*****	*****	*****	*****	*****
0.650	-0.4936	-0.3539	-0.4450	-0.6369	-0.9472	*****	*****	*****	*****	*****
0.675	*****	-0.3519	-0.7230	-0.8704	-1.0879	*****	*****	*****	*****	*****
0.700	-0.5398	-0.3452	-0.9871	-1.0852	-0.9476	*****	*****	*****	*****	*****
0.725	*****	-0.4330	*****	-1.2409	-0.7930	*****	*****	*****	*****	*****
0.750	-0.5740	-0.8767	*****	-1.3132	-0.7441	*****	*****	*****	*****	*****
0.775	*****	-1.2721	-1.1749	-1.1717	-0.6780	*****	*****	*****	*****	*****
0.800	-0.6247	-1.3508	-1.1066	-0.9768	*****	*****	*****	*****	*****	*****
0.825	*****	-1.3214	-1.0881	-0.9017	-0.5661	*****	*****	*****	*****	*****
0.850	-1.0036	-1.2741	-1.0666	-0.8856	-0.5257	*****	*****	*****	*****	*****
0.875	*****	-1.1860	-1.0202	-0.8759	-0.5280	*****	*****	*****	*****	*****
0.900	-1.2096	-1.0692	-0.9514	-0.8131	-0.5417	*****	*****	*****	*****	*****
0.925	*****	-1.0504	-0.8814	-0.7419	-0.6207	*****	*****	*****	*****	*****
0.950	-1.2489	-1.2645	-0.8329	-0.7248	-0.5803	*****	*****	*****	*****	*****
0.975	*****	-1.1969	-0.8042	-0.6343	-0.4902	*****	*****	*****	*****	*****
1.000	-1.2097	-1.2302	-0.8381	-0.9798	-0.6197	*****	*****	*****	*****	*****
-0.200	$C_{p,l}$	$C_{p,l}$	$C_{p,l}$	$C_{p,l}$	$C_{p,l}$	$C_{p,l}$	$C_{p,l}$	$C_{p,l}$	$C_{p,l}$	$C_{p,l}$
-0.400	0.2798	0.2660	0.2848	*****	*****	*****	*****	*****	*****	-0.5560
-0.600	0.2800	0.2756	0.2554	0.0839	-0.6718	*****	*****	*****	*****	*****
-0.700	0.3004	0.2766	0.2537	0.1178	-0.6483	*****	*****	*****	*****	*****
-0.800	0.3156	0.2841	0.2535	0.1357	-0.6236	*****	*****	*****	*****	*****
-0.850	0.3309	0.3013	0.2625	0.1602	-0.5444	*****	*****	*****	*****	*****
-0.900	*****	0.3122	0.2726	0.1713	-0.5331	*****	*****	*****	*****	*****
-0.950	*****	0.3116	0.2774	0.1893	-0.4912	*****	*****	*****	*****	*****
-0.975	0.2402	0.2607	0.2466	0.1935	-0.1661	*****	*****	*****	*****	*****
-1.000	*****	0.1419	0.1546	0.1322	-0.0411	*****	*****	*****	*****	*****
	-1.1989	-1.0756	-1.0175	-0.9052	-0.5338	*****	*****	*****	*****	*****

Medium Radius L.E.
 Run No. = 11, Point No. = 232
 $C_N = 0.643$, $C_m = -0.1299$
 $\alpha = 13.2^\circ$, $M_\infty = 0.848$
 $R_{mac} = 23.9 \times 10^6$

Leading Edge Pressures



x/c_R	starb'd C_p	port C_p
0.10	-0.8641	*****
0.20	-1.2097	-1.1989
0.30	-1.3705	*****
0.40	-1.2302	-1.0756
0.50	-1.1129	*****
0.60	-0.8381	-1.0175
0.70	-0.8561	*****
0.80	-0.9798	-0.9052
0.90	-0.0906	*****
0.95	-0.6197	-0.5338

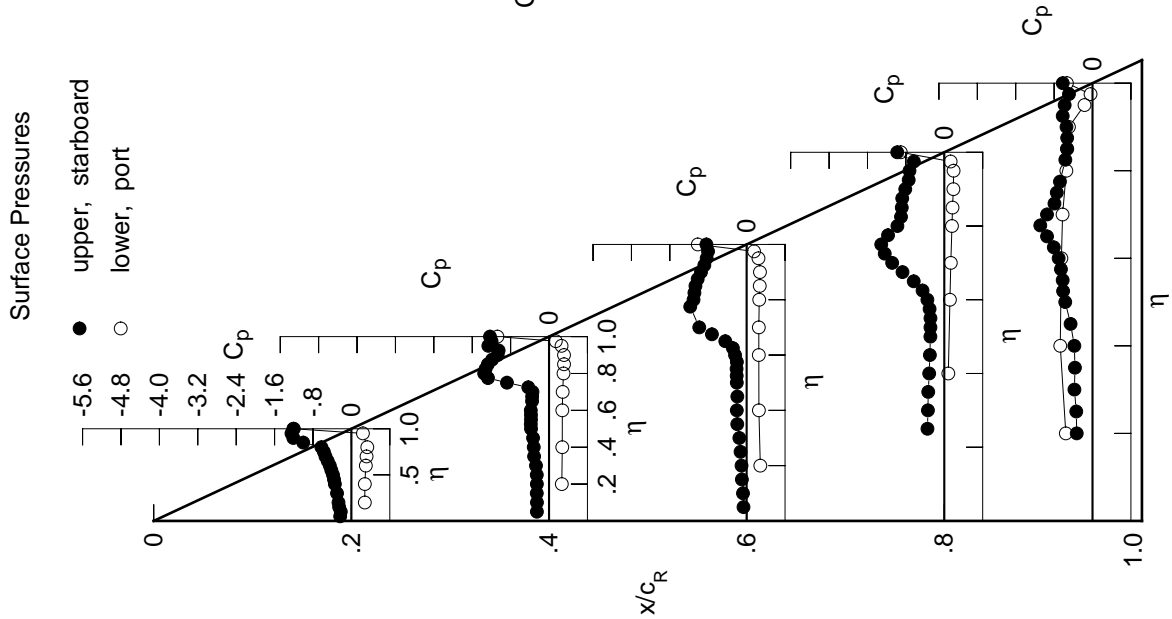
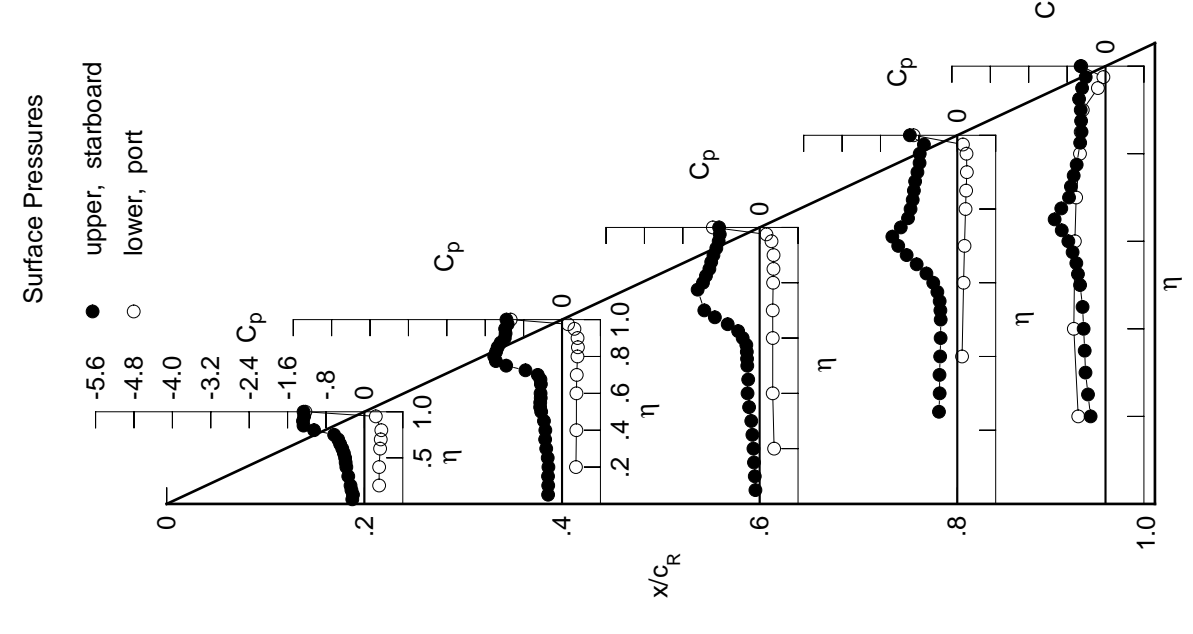
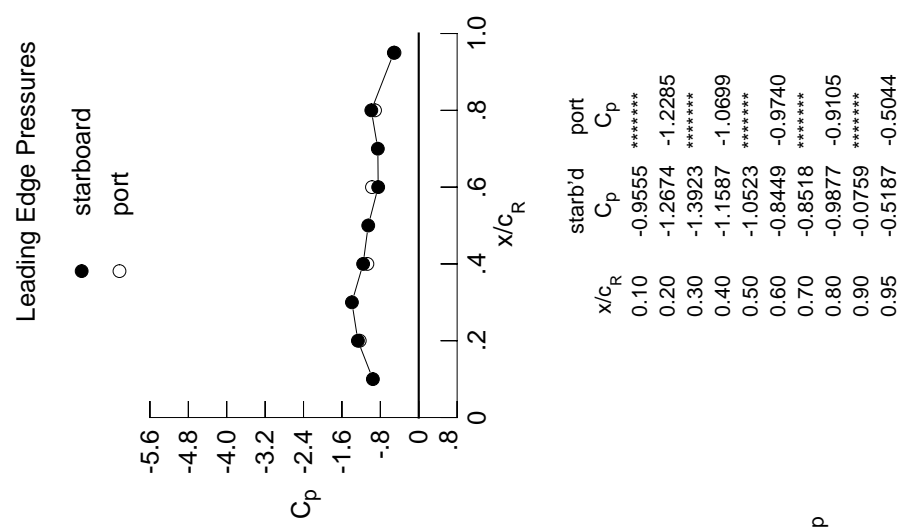

Table E3. Continued.

η	$x/c_R = 0.2$		$x/c_R = 0.4$		$x/c_R = 0.6$		$x/c_R = 0.8$		$x/c_R = 0.95$	
	$C_{p,u}$	$C_{p,l}$	$C_{p,u}$	$C_{p,l}$	$C_{p,u}$	$C_{p,l}$	$C_{p,u}$	$C_{p,l}$	$C_{p,u}$	$C_{p,l}$
0.050	-0.2522	-0.2906	-0.0877	*****	*****	*****	*****	*****	*****	*****
0.100	-0.2377	-0.2877	-0.1013	*****	*****	*****	*****	*****	*****	*****
0.150	-0.2697	-0.2921	-0.1181	*****	*****	*****	*****	*****	*****	*****
0.200	-0.2887	-0.2838	-0.1296	*****	*****	*****	*****	*****	*****	*****
0.250	*****	-0.2983	-0.1508	-0.3813	-0.3646	*****	*****	*****	*****	*****
0.300	-0.3357	-0.3297	-0.1741	-0.3670	-0.4167	*****	*****	*****	*****	*****
0.350	*****	-0.3523	-0.2204	-0.3703	-0.4339	*****	*****	*****	*****	*****
0.400	-0.3758	-0.3482	-0.2520	-0.3565	-0.4560	*****	*****	*****	*****	*****
0.450	-0.3902	-0.3764	-0.2383	-0.3472	-0.4775	*****	*****	*****	*****	*****
0.500	-0.4012	-0.4343	-0.2576	-0.3453	-0.5297	*****	*****	*****	*****	*****
0.525	*****	-0.4562	-0.2626	-0.3517	-0.5743	*****	*****	*****	*****	*****
0.550	-0.4275	-0.4547	-0.2674	-0.3675	-0.6079	*****	*****	*****	*****	*****
0.575	*****	-0.4443	-0.2773	-0.4153	-0.6856	*****	*****	*****	*****	*****
0.600	-0.4608	-0.4470	-0.3538	-0.5008	-0.7746	*****	*****	*****	*****	*****
0.625	*****	*****	-0.4478	-0.6428	-0.9120	*****	*****	*****	*****	*****
0.650	-0.5057	-0.4404	-0.6654	-0.8462	-1.0601	*****	*****	*****	*****	*****
0.675	*****	-0.4493	-0.9325	-1.0549	-0.9218	*****	*****	*****	*****	*****
0.700	-0.5462	-0.5056	-1.1526	-1.2301	-0.7599	*****	*****	*****	*****	*****
0.725	*****	-0.7618	*****	-1.3526	-0.7206	*****	*****	*****	*****	*****
0.750	-0.6302	-1.1629	*****	-1.1772	-0.6636	*****	*****	*****	*****	*****
0.775	*****	-1.3784	-1.2924	-1.0266	-0.6010	*****	*****	*****	*****	*****
0.800	-1.0489	-1.4126	-1.1806	-0.9738	*****	*****	*****	*****	*****	*****
0.825	*****	-1.3754	-1.1183	-0.9288	-0.5277	*****	*****	*****	*****	*****
0.850	-1.2677	-1.3407	-1.0473	-0.9043	-0.4992	*****	*****	*****	*****	*****
0.875	*****	-1.2791	-1.0090	-0.8784	-0.5088	*****	*****	*****	*****	*****
0.900	-1.2788	-1.1931	-0.9620	-0.8305	-0.5163	*****	*****	*****	*****	*****
0.925	*****	-1.1760	-0.9023	-0.7858	-0.5516	*****	*****	*****	*****	*****
0.950	-1.2552	-1.1853	-0.8535	-0.7827	-0.4878	*****	*****	*****	*****	*****
0.975	*****	-1.1328	-0.8306	-0.6956	-0.4130	*****	*****	*****	*****	*****
1.000	-1.2674	-1.1587	-0.8449	-0.9877	-0.5187	*****	*****	*****	*****	*****
-0.200	$C_{p,l}$	0.3070	0.2892	0.3017	*****	*****	*****	*****	*****	*****
-0.400	0.3075	0.2987	0.2723	0.0995	-0.6604	*****	*****	*****	*****	*****
-0.600	0.3276	0.3001	0.2731	0.1312	-0.6381	*****	*****	*****	*****	*****
-0.700	0.3412	0.3061	0.2725	0.1501	-0.6116	*****	*****	*****	*****	*****
-0.800	0.3526	0.3218	0.2810	0.1720	-0.5324	*****	*****	*****	*****	*****
-0.850	*****	0.3302	0.2882	0.1840	-0.5178	*****	*****	*****	*****	*****
-0.900	*****	0.3230	0.2895	0.1993	-0.4736	*****	*****	*****	*****	*****
-0.950	0.2377	0.2586	0.2473	0.1921	-0.1586	*****	*****	*****	*****	*****
-0.975	*****	0.1257	0.1419	0.1178	-0.0439	*****	*****	*****	*****	*****
-1.000	-1.2285	-1.0699	-0.9740	-0.9105	-0.5044	*****	*****	*****	*****	*****

Medium Radius L.E.
 Run No. = 11, Point No. = 233
 $C_N = 0.700$, $C_m = -0.1381$
 $\alpha = 14.3^\circ$, $M_\infty = 0.849$
 $R_{mac} = 23.8 \times 10^6$



x/c_R	starb'd C_p	port C_p
0.10	-0.9555	*****
0.20	-1.2674	-1.2285
0.30	-1.3923	*****
0.40	-1.1587	-1.0699
0.50	-1.0523	*****
0.60	-0.8449	-0.9740
0.70	-0.8518	*****
0.80	-0.9877	-0.9105
0.90	-0.0759	*****
0.95	-0.5187	-0.5044

Table E3. Continued.

η	$x/c_R = .2$		$x/c_R = .4$		$x/c_R = .6$		$x/c_R = .8$		$x/c_R = .95$	
	$C_{p,u}$	$C_{p,l}$	$C_{p,u}$	$C_{p,l}$	$C_{p,u}$	$C_{p,l}$	$C_{p,u}$	$C_{p,l}$	$C_{p,u}$	$C_{p,l}$
0.050	-0.3106	-0.3649	-0.1271	*****	*****	*****	*****	*****	*****	*****
0.100	-0.2885	-0.3640	-0.1365	*****	*****	*****	*****	*****	*****	*****
0.150	-0.3208	-0.3593	-0.1528	*****	*****	*****	*****	*****	*****	*****
0.200	-0.3244	-0.3540	-0.1701	*****	*****	*****	*****	*****	*****	*****
0.250	*****	-0.3809	-0.1904	-0.4529	-0.4214	*****	*****	*****	*****	*****
0.300	-0.4430	-0.3779	-0.1962	-0.4307	-0.4291	*****	*****	*****	*****	*****
0.350	*****	-0.3783	-0.2128	-0.4125	-0.5060	*****	*****	*****	*****	*****
0.400	-0.4099	-0.3884	-0.2266	-0.3988	-0.6284	*****	*****	*****	*****	*****
0.450	-0.4319	-0.4296	-0.2322	-0.4033	-0.6789	*****	*****	*****	*****	*****
0.500	-0.4704	-0.5298	-0.3409	-0.4578	-0.7192	*****	*****	*****	*****	*****
0.525	*****	-0.6420	-0.4465	-0.5290	-0.7674	*****	*****	*****	*****	*****
0.550	-0.5064	-0.7403	-0.6027	-0.6430	-0.8314	*****	*****	*****	*****	*****
0.575	*****	-0.8298	-0.7923	-0.7978	-0.9466	*****	*****	*****	*****	*****
0.600	-0.5381	-0.9268	-1.0371	-0.9683	-1.0676	*****	*****	*****	*****	*****
0.625	*****	*****	-1.2034	-1.1276	-1.1978	*****	*****	*****	*****	*****
0.650	-0.7720	-1.1293	-1.3335	-1.2700	-0.8460	*****	*****	*****	*****	*****
0.675	*****	-1.2207	-1.4159	-1.3776	-0.7971	*****	*****	*****	*****	*****
0.700	-0.8735	-1.2663	-1.4051	-1.4501	-0.7724	*****	*****	*****	*****	*****
0.725	*****	-1.2746	*****	-1.3056	-0.7100	*****	*****	*****	*****	*****
0.750	-0.9118	-1.2796	*****	-1.1542	-0.6434	*****	*****	*****	*****	*****
0.775	*****	-1.2728	-1.1451	-1.1120	-0.5896	*****	*****	*****	*****	*****
0.800	-1.2269	-1.2548	-1.1096	-1.0632	*****	*****	*****	*****	*****	*****
0.825	*****	-1.2231	-1.0932	-1.0042	-0.5340	*****	*****	*****	*****	*****
0.850	-1.4188	-1.1922	-1.0504	-0.9930	-0.5090	*****	*****	*****	*****	*****
0.875	*****	-1.1595	-1.0023	-1.0025	-0.5319	*****	*****	*****	*****	*****
0.900	-1.3680	-1.1346	-0.9596	-0.9191	-0.5243	*****	*****	*****	*****	*****
0.925	*****	-1.1214	-0.9247	-0.7923	-0.5296	*****	*****	*****	*****	*****
0.950	-1.3009	-1.0991	-0.8866	-0.7795	-0.4602	*****	*****	*****	*****	*****
0.975	*****	-1.0781	-0.8617	-0.7306	-0.3970	*****	*****	*****	*****	*****
1.000	-1.3561	-1.1085	-0.8739	-0.9222	-0.4730	*****	*****	*****	*****	*****
-0.200	$C_{p,l}$	0.3630	0.3376	0.3374	*****	*****	*****	*****	*****	*****
-0.400		0.3646	0.3440	0.3101	0.1304	-0.6428	*****	*****	*****	*****
-0.600		0.3827	0.3477	0.3082	0.1622	-0.6195	*****	*****	*****	*****
-0.700		0.3919	0.3513	0.3102	0.1794	-0.5900	*****	*****	*****	*****
-0.800		0.3931	0.3613	0.3141	0.2007	-0.5076	*****	*****	*****	*****
-0.850		*****	0.3611	0.3183	0.2096	-0.4918	*****	*****	*****	*****
-0.900		*****	0.3433	0.3100	0.2197	-0.4431	*****	*****	*****	*****
-0.950		0.2281	0.2527	0.2441	0.1921	-0.1468	*****	*****	*****	*****
-0.975		*****	0.0929	0.1138	0.0958	-0.0520	*****	*****	*****	*****
-1.000		-1.2829	-1.0581	-0.9307	-0.8896	-0.4680	*****	*****	*****	*****

Medium Radius L.E.
 Run No. = 11, Point No. = 234
 $C_N = 0.820$, $C_m = -0.1582$
 $\alpha = 16.3^\circ$, $M_\infty = 0.848$
 $R_{mac} = 23.7 \times 10^6$

Leading Edge Pressures

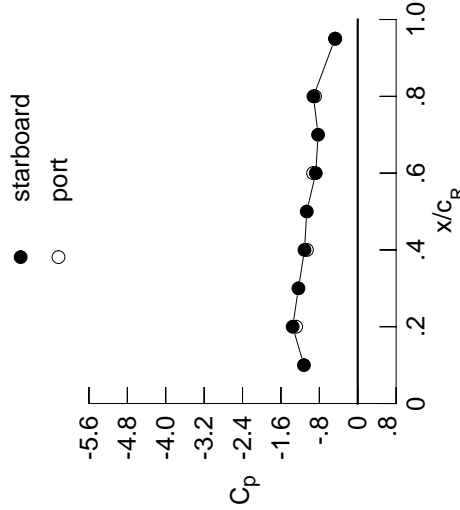

x/c_R	starb'd C_p	port C_p
0.10	-1.1207	*****
0.20	-1.3561	-1.2829
0.30	-1.2353	*****
0.40	-1.1085	-1.0581
0.50	-1.0627	*****
0.60	-0.8739	-0.9307
0.70	-0.8261	*****
0.80	-0.9222	-0.8896
0.90	-0.0416	*****
0.95	-0.4730	-0.4680

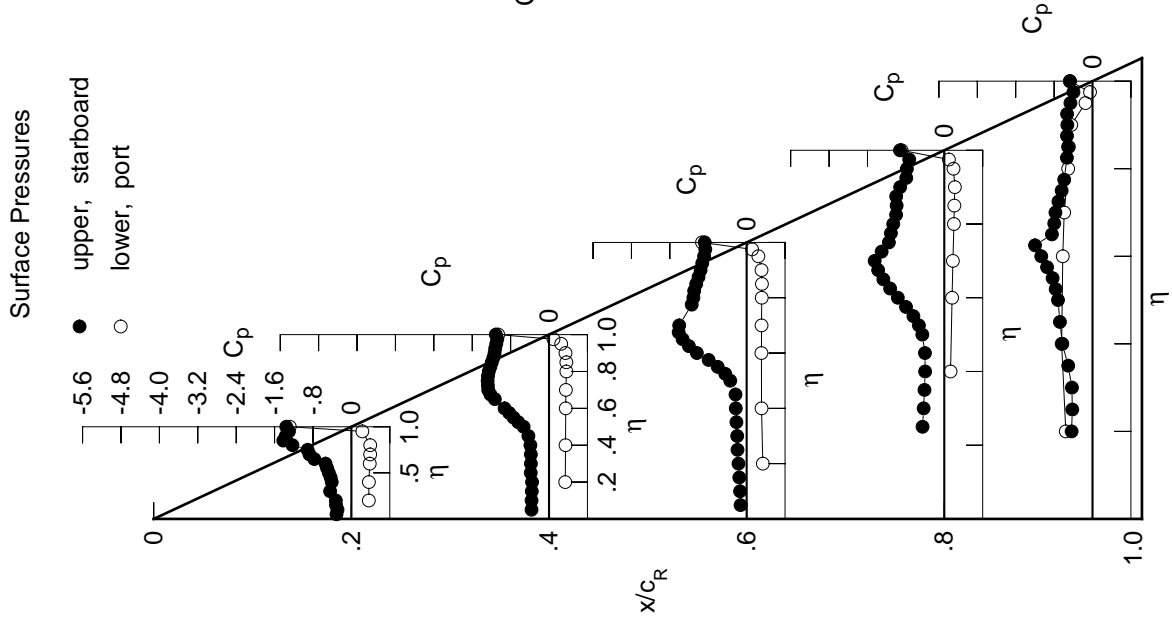
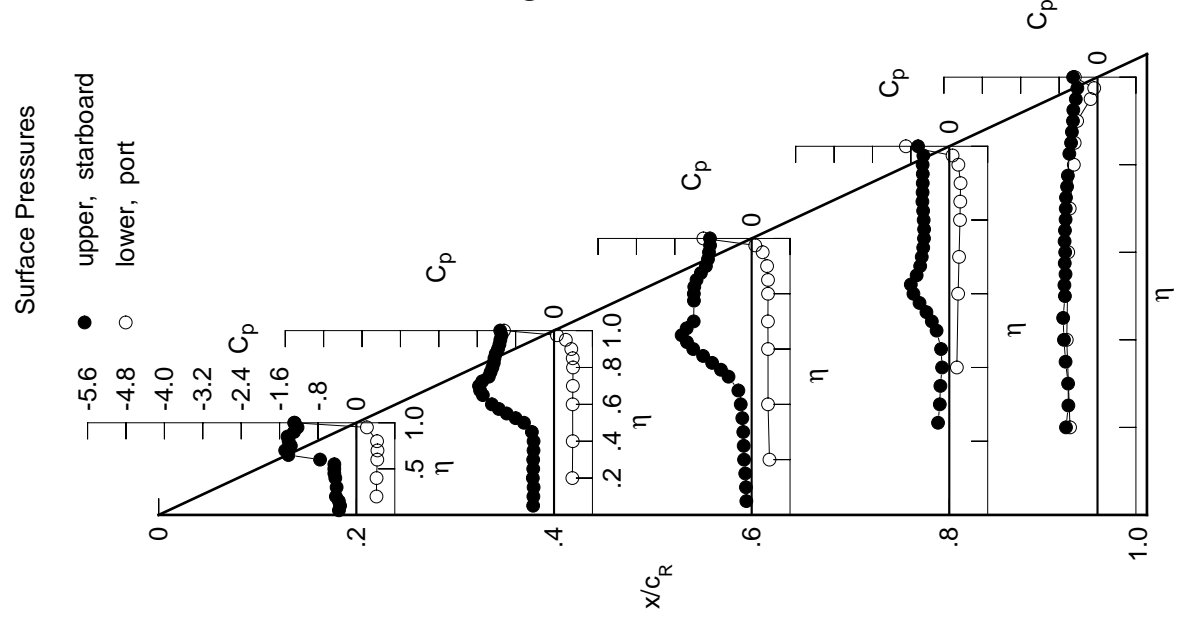
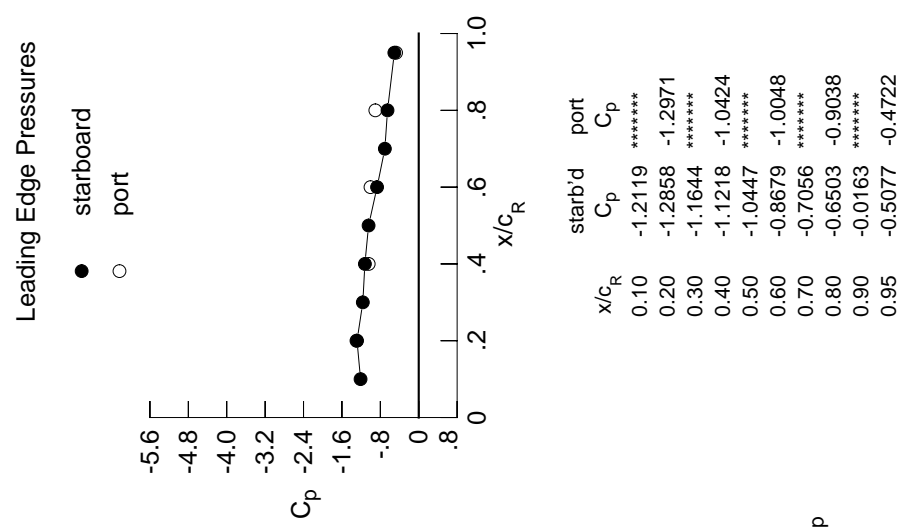

Table E3. Continued.

η	$x/c_R = .2$		$x/c_R = .4$		$x/c_R = .6$		$x/c_R = .8$		$x/c_R = .95$	
	$C_{p,u}$	$C_{p,u}$	$C_{p,u}$	$C_{p,u}$	$C_{p,u}$	$C_{p,u}$	$C_{p,u}$	$C_{p,u}$	$C_{p,u}$	$C_{p,u}$
0.050	-0.3642	-0.4355	-0.1104	*****	*****	*****	*****	*****	*****	*****
0.100	-0.3397	-0.4305	-0.1195	*****	*****	*****	*****	*****	*****	*****
0.150	-0.3657	-0.4258	-0.1334	*****	*****	*****	*****	*****	*****	*****
0.200	-0.4273	-0.4416	-0.1584	*****	*****	*****	*****	*****	*****	*****
0.250	*****	-0.4336	-0.1659	-0.2343	-0.2343	-0.6072	*****	*****	*****	*****
0.300	-0.4119	-0.4341	-0.1743	-0.1976	-0.1976	-0.6127	*****	*****	*****	*****
0.350	*****	-0.4273	-0.1946	-0.1855	-0.1855	-0.6654	*****	*****	*****	*****
0.400	-0.4394	-0.4262	-0.2270	-0.1502	-0.1502	-0.6993	*****	*****	*****	*****
0.450	-0.4590	-0.4615	-0.2765	-0.1708	-0.1708	-0.7161	*****	*****	*****	*****
0.500	-0.4596	-0.6265	-0.4813	-0.2644	-0.2644	-0.6789	*****	*****	*****	*****
0.525	*****	-0.7997	-0.6391	-0.3636	-0.3636	-0.6898	*****	*****	*****	*****
0.550	-0.4588	-0.9857	-0.8231	-0.4762	-0.4762	-0.6661	*****	*****	*****	*****
0.575	*****	-1.1514	-1.0112	-0.6197	-0.6828	*****	*****	*****	*****	*****
0.600	-0.7566	-1.2942	-1.2172	-0.7470	-0.6736	*****	*****	*****	*****	*****
0.625	*****	*****	-1.3471	-0.8019	-0.6856	*****	*****	*****	*****	*****
0.650	-1.4167	-1.4834	-1.4587	-0.6803	-0.6781	*****	*****	*****	*****	*****
0.675	*****	-1.5399	-1.3535	-0.6061	-0.6649	*****	*****	*****	*****	*****
0.700	-1.4834	-1.5634	-1.2074	-0.5734	-0.6620	*****	*****	*****	*****	*****
0.725	*****	-1.4958	*****	-0.5434	-0.6568	*****	*****	*****	*****	*****
0.750	-1.3659	-1.3590	*****	-0.5271	-0.6348	*****	*****	*****	*****	*****
0.775	*****	-1.3213	-1.2021	-0.5251	-0.6173	*****	*****	*****	*****	*****
0.800	-1.4113	-1.2842	-1.2041	-0.5338	*****	*****	*****	*****	*****	*****
0.825	*****	-1.2549	-1.1948	-0.5445	-0.5875	*****	*****	*****	*****	*****
0.850	-1.4349	-1.2414	-1.1477	-0.5603	-0.5511	*****	*****	*****	*****	*****
0.875	*****	-1.2142	-1.0577	-0.5560	-0.5334	*****	*****	*****	*****	*****
0.900	-1.2999	-1.1683	-0.9527	-0.5530	-0.5114	*****	*****	*****	*****	*****
0.925	*****	-1.1379	-0.9099	-0.5523	-0.5039	*****	*****	*****	*****	*****
0.950	-1.2261	-1.1183	-0.8885	-0.5551	-0.4519	*****	*****	*****	*****	*****
0.975	*****	-1.0947	-0.8662	-0.5400	-0.4198	*****	*****	*****	*****	*****
1.000	-1.2858	-1.1218	-0.8679	-0.6503	-0.5077	*****	*****	*****	*****	*****
-0.200	$C_{p,l}$	0.3817	0.3716	*****	-0.5722	*****	*****	*****	*****	*****
-0.400	0.4199	0.3893	0.3416	0.1573	-0.6406	*****	*****	*****	*****	*****
-0.600	0.4356	0.3876	0.3413	0.1842	-0.6107	*****	*****	*****	*****	*****
-0.700	0.4393	0.3922	0.3391	0.2031	-0.5792	*****	*****	*****	*****	*****
-0.800	0.4305	0.3957	0.3415	0.2229	-0.4936	*****	*****	*****	*****	*****
-0.850	*****	0.3899	0.3406	0.2287	-0.4761	*****	*****	*****	*****	*****
-0.900	*****	0.3593	0.3218	0.2348	-0.4250	*****	*****	*****	*****	*****
-0.950	0.2189	0.2456	0.2307	0.1891	-0.1441	*****	*****	*****	*****	*****
-0.975	*****	0.0603	0.0748	0.0676	-0.0686	*****	*****	*****	*****	*****
-1.000	-1.2971	-1.0424	-1.0048	-0.9038	-0.4722	*****	*****	*****	*****	*****

Medium Radius L.E.
 Run No. = 11, Point No. = 235
 $C_N = 0.849$, $C_m = -0.1418$
 $\alpha = 18.3^\circ$, $M_\infty = 0.850$
 $R_{mac} = 23.7 \times 10^6$



x/c_R	starb'd C_p	port C_p
0.10	-1.2119	*****
0.20	-1.2858	-1.2971
0.30	-1.1644	*****
0.40	-1.1218	-1.0424
0.50	-1.0447	*****
0.60	-0.8679	-1.0048
0.70	-0.7056	*****
0.80	-0.6503	-0.9038
0.90	-0.0163	*****
0.95	-0.5077	-0.4722

Table E3. Continued.

η	x/c_R .2	x/c_R .4	x/c_R .6	x/c_R .8	x/c_R .95
	$C_{p,u}$	$C_{p,u}$	$C_{p,u}$	$C_{p,u}$	$C_{p,u}$
0.050	-0.4259	-0.4949	-0.1044	*****	*****
0.100	-0.3872	-0.4909	-0.1139	*****	*****
0.150	-0.4644	-0.4941	-0.1243	*****	*****
0.200	-0.4633	-0.5070	-0.1529	*****	-0.5064
0.250	*****	-0.5086	-0.1613	-0.4572	-0.4976
0.300	-0.4639	-0.5141	-0.1816	-0.4721	-0.5265
0.350	*****	-0.5274	-0.2252	-0.5235	-0.5863
0.400	-0.4887	-0.5735	-0.3038	-0.5782	-0.6730
0.450	-0.4980	-0.7031	-0.4297	-0.6859	-0.7340
0.500	-0.5303	-0.9395	-0.7162	-0.8174	-0.7171
0.525	*****	-1.0937	-0.8925	-0.8708	-0.7245
0.550	-0.8520	-1.2385	-1.0559	-0.9014	-0.6986
0.575	*****	-1.3700	-1.2065	-0.9165	-0.7068
0.600	-1.4281	-1.4659	-1.3623	-0.9210	-0.6936
0.625	*****	*****	-1.4505	-0.9133	-0.7006
0.650	-1.6884	-1.6260	-1.1745	-0.9067	-0.6932
0.675	*****	-1.5684	-1.1117	-0.8668	-0.6770
0.700	-1.5561	-1.4429	-1.0946	-0.8216	-0.6689
0.725	*****	-1.4145	*****	-0.7859	-0.6547
0.750	-1.4638	-1.4037	*****	-0.7499	-0.6355
0.775	*****	-1.3946	-1.0847	-0.7343	-0.6190
0.800	-1.4866	-1.4104	-1.1446	-0.7269	*****
0.825	*****	-1.4129	-1.1788	-0.7185	-0.5846
0.850	-1.4029	-1.3289	-1.0654	-0.7307	-0.5495
0.875	*****	-1.2216	-0.9562	-0.7411	-0.5246
0.900	-1.3045	-1.1919	-0.9191	-0.7594	-0.4932
0.925	*****	-1.1947	-0.9281	-0.7872	-0.4711
0.950	-1.2406	-1.1929	-0.9122	-0.8122	-0.4294
0.975	*****	-1.1832	-0.8784	-0.7991	-0.3995
1.000	-1.2837	-1.1942	-0.8644	-0.8803	-0.4398
	$C_{p,l}$	$C_{p,l}$	$C_{p,l}$	$C_{p,l}$	$C_{p,l}$
-0.200	0.4761	0.4277	0.4053	*****	-0.5455
-0.400	0.4752	0.4339	0.3828	0.1888	-0.6158
-0.600	0.4879	0.4314	0.3766	0.2176	-0.5845
-0.700	0.4870	0.4346	0.3761	0.2296	-0.5551
-0.800	0.4662	0.4304	0.3735	0.2502	-0.4655
-0.850	*****	0.4177	0.3677	0.2521	-0.4466
-0.900	*****	0.3702	0.3367	0.2491	-0.3926
-0.950	0.2064	0.2325	0.2198	0.1793	-0.1332
-0.975	*****	0.0209	0.0395	0.0348	-0.0812
-1.000	-1.2808	-1.1571	-1.0302	-0.9758	-0.4730

Medium Radius L.E.
 Run No. = 11, Point No. = 236
 $C_N = 0.987$, $C_m = -0.1844$
 $\alpha = 20.4^\circ$, $M_\infty = 0.850$
 $R_{mac} = 23.9 \times 10^6$

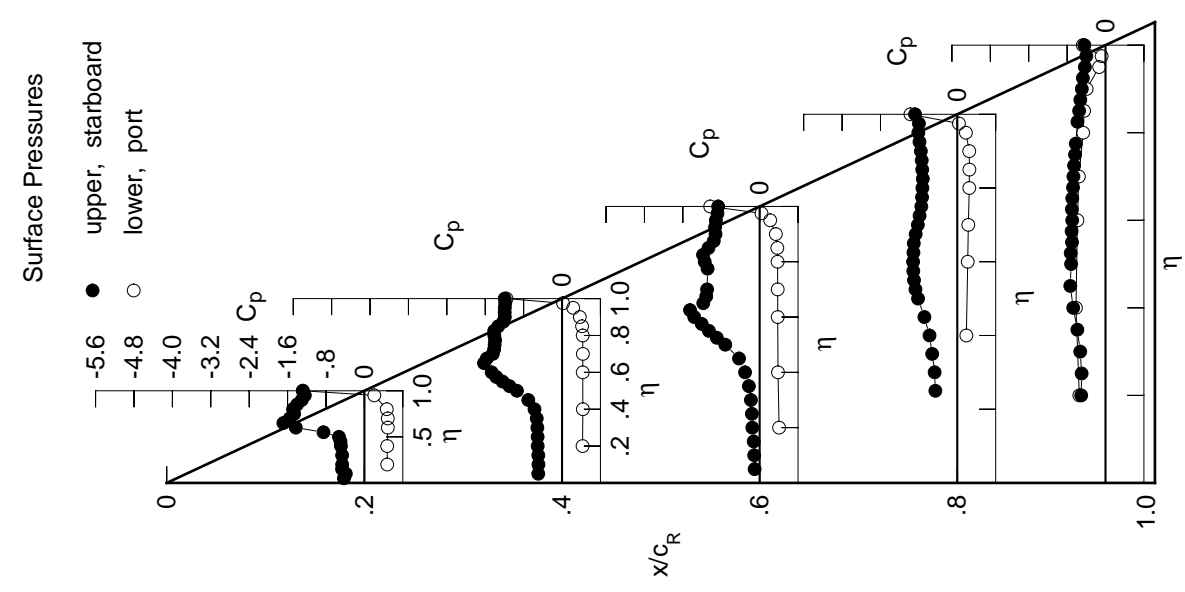
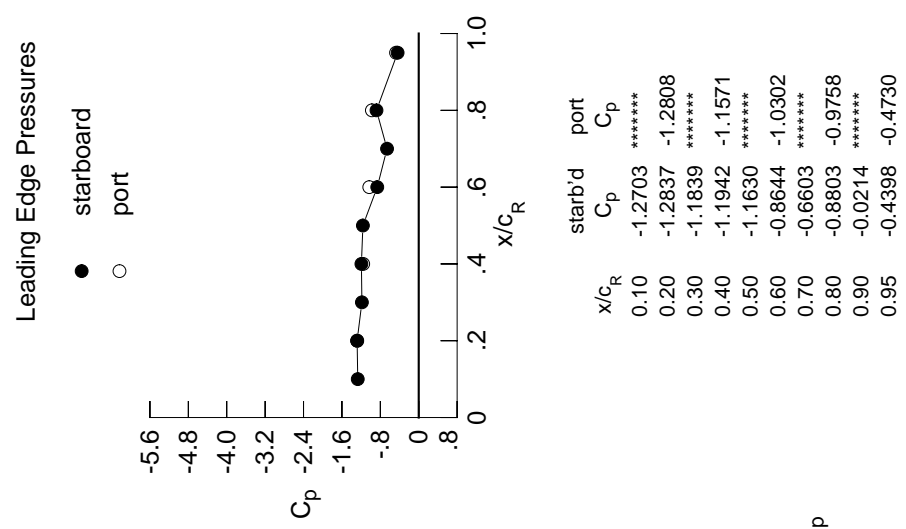

Table E3. Continued.

η	$x/c_R = .2$		$x/c_R = .4$		$x/c_R = .6$		$x/c_R = .8$		$x/c_R = .95$	
	$C_{p,u}$	$C_{p,u}$	$C_{p,u}$	$C_{p,u}$	$C_{p,u}$	$C_{p,u}$	$C_{p,u}$	$C_{p,u}$	$C_{p,u}$	$C_{p,u}$
0.050	-0.4942	-0.5653	-0.1218	*****	*****	*****	*****	*****	*****	*****
0.100	-0.4457	-0.5605	-0.1251	*****	*****	*****	*****	*****	*****	*****
0.150	-0.5313	-0.5618	-0.1346	*****	*****	*****	*****	*****	*****	*****
0.200	-0.5242	-0.5840	-0.1428	*****	*****	*****	*****	*****	*****	-0.5646
0.250	*****	-0.5872	-0.1613	-0.6657	-0.6007	*****	*****	*****	*****	*****
0.300	-0.5266	-0.6169	-0.2134	-0.6845	-0.6461	*****	*****	*****	*****	*****
0.350	*****	-0.6644	-0.2717	-0.7480	-0.7008	*****	*****	*****	*****	*****
0.400	-0.5582	-0.7611	-0.4051	-0.7946	-0.7502	*****	*****	*****	*****	*****
0.450	-0.6300	-0.9362	-0.5924	-0.8602	-0.7386	*****	*****	*****	*****	*****
0.500	-0.8832	-1.1605	-0.9208	-0.8989	-0.7100	*****	*****	*****	*****	*****
0.525	*****	-1.2840	-1.0807	-0.9105	-0.7253	*****	*****	*****	*****	*****
0.550	-1.3491	-1.4015	-1.2108	-0.9104	-0.7134	*****	*****	*****	*****	*****
0.575	*****	-1.5058	-1.3342	-0.9182	-0.7341	*****	*****	*****	*****	*****
0.600	-1.6602	-1.5906	-1.4440	-0.9319	-0.7265	*****	*****	*****	*****	*****
0.625	*****	*****	-1.3038	-0.9261	-0.7343	*****	*****	*****	*****	*****
0.650	-1.7996	-1.4487	-1.1272	-0.9116	-0.7259	*****	*****	*****	*****	*****
0.675	*****	-1.4446	-1.0821	-0.8907	-0.7091	*****	*****	*****	*****	*****
0.700	-1.6556	-1.4289	-1.0547	-0.8617	-0.7028	*****	*****	*****	*****	*****
0.725	*****	-1.4316	*****	-0.8387	-0.6884	*****	*****	*****	*****	*****
0.750	-1.5390	-1.4300	*****	-0.8139	-0.6681	*****	*****	*****	*****	*****
0.775	*****	-1.4451	-0.9947	-0.7986	-0.6462	*****	*****	*****	*****	*****
0.800	-1.4638	-1.4606	-1.0020	-0.7883	*****	*****	*****	*****	*****	*****
0.825	*****	-1.4053	-1.0194	-0.7841	-0.6079	*****	*****	*****	*****	*****
0.850	-1.3904	-1.3393	-0.9378	-0.7875	-0.5796	*****	*****	*****	*****	*****
0.875	*****	-1.3014	-0.8536	-0.7831	-0.5598	*****	*****	*****	*****	*****
0.900	-1.3369	-1.2937	-0.8026	-0.7824	-0.5309	*****	*****	*****	*****	*****
0.925	*****	-1.3011	-0.7855	-0.7743	-0.5169	*****	*****	*****	*****	*****
0.950	-1.2788	-1.2902	-0.7636	-0.7776	-0.4730	*****	*****	*****	*****	*****
0.975	*****	-1.2813	-0.7440	-0.7640	-0.4377	*****	*****	*****	*****	*****
1.000	-1.3055	-1.2881	-0.7538	-0.8040	-0.4536	*****	*****	*****	*****	*****
-0.200	$C_{p,l}$	$C_{p,l}$	$C_{p,l}$	$C_{p,l}$	$C_{p,l}$	$C_{p,l}$	$C_{p,l}$	$C_{p,l}$	$C_{p,l}$	$C_{p,l}$
-0.400	0.5350	0.4789	0.4487	*****	*****	*****	*****	*****	*****	-0.5221
-0.600	0.5330	0.4852	0.4200	0.2218	-0.5898	*****	*****	*****	*****	*****
-0.700	0.5403	0.4789	0.4181	0.2529	-0.5627	*****	*****	*****	*****	*****
-0.800	0.5317	0.4776	0.4122	0.2608	-0.5263	*****	*****	*****	*****	*****
-0.850	0.5000	0.4662	0.4052	0.2790	-0.4375	*****	*****	*****	*****	*****
-0.850	*****	0.4428	0.3939	0.2766	-0.4186	*****	*****	*****	*****	*****
-0.900	*****	0.3825	0.3508	0.2630	-0.3654	*****	*****	*****	*****	*****
-0.950	0.1924	0.2203	0.2092	0.1732	-0.1231	*****	*****	*****	*****	*****
-0.975	*****	-0.0176	0.0057	0.0057	-0.0928	*****	*****	*****	*****	*****
-1.000	-1.3075	-1.2719	-1.1154	-1.0243	-0.4752	*****	*****	*****	*****	*****

Medium Radius L.E.
 Run No. = 11, Point No. = 237
 $C_N = 1.087$, $C_m = -0.2009$
 $\alpha = 22.4^\circ$, $M_\infty = 0.849$
 $R_{mac} = 24.0 \times 10^6$

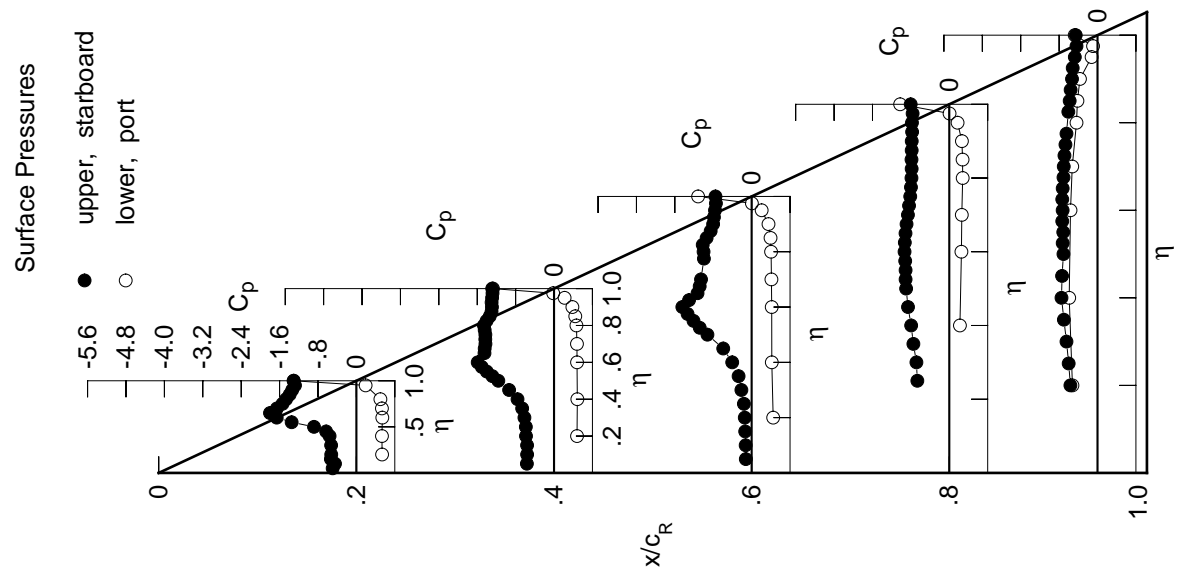
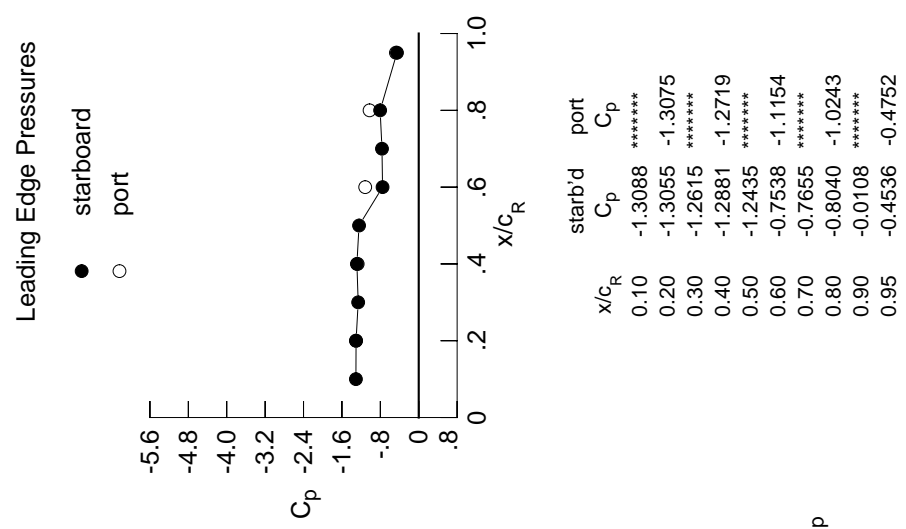
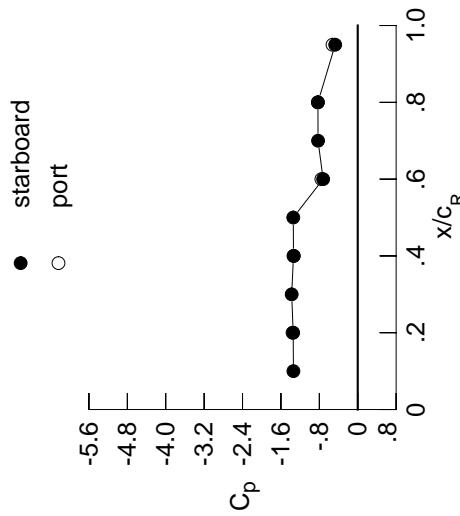

Table E3. Continued.

η	$x/c_R = 0.2$		$x/c_R = 0.4$		$x/c_R = 0.6$		$x/c_R = 0.8$		$x/c_R = 0.95$	
	$C_{p,u}$	$C_{p,u}$	$C_{p,u}$	$C_{p,u}$	$C_{p,u}$	$C_{p,u}$	$C_{p,u}$	$C_{p,u}$	$C_{p,u}$	$C_{p,u}$
0.050	-0.5785	-0.6513	-0.0193	*****	*****	*****	*****	*****	*****	*****
0.100	-0.5331	-0.6498	-0.0325	*****	*****	*****	*****	*****	*****	*****
0.150	-0.5862	-0.6545	-0.0498	*****	*****	*****	*****	*****	*****	*****
0.200	-0.6069	-0.6630	-0.0700	*****	*****	*****	*****	*****	*****	-0.5685
0.250	*****	-0.6942	-0.1067	-0.7864	-0.6353	*****	*****	*****	*****	-0.6353
0.300	-0.6263	-0.7402	-0.1673	-0.8158	-0.6998	*****	*****	*****	*****	-0.6998
0.350	*****	-0.8223	-0.2824	-0.8811	-0.7681	*****	*****	*****	*****	-0.7681
0.400	-0.7377	-0.9476	-0.4659	-0.9316	-0.8311	*****	*****	*****	*****	-0.8311
0.450	-0.9414	-1.1281	-0.7006	-0.9861	-0.8299	*****	*****	*****	*****	-0.8299
0.500	-1.2757	-1.3245	-1.0068	-0.9971	-0.7783	*****	*****	*****	*****	-0.7783
0.525	*****	-1.4224	-1.1485	-0.9935	-0.7810	*****	*****	*****	*****	-0.7810
0.550	-1.5764	-1.5214	-1.2671	-0.9663	-0.7584	*****	*****	*****	*****	-0.7584
0.575	*****	-1.6016	-1.3665	-0.9659	-0.7748	*****	*****	*****	*****	-0.7748
0.600	-1.7525	-1.6682	-1.4520	-0.9652	-0.7696	*****	*****	*****	*****	-0.7696
0.625	*****	*****	-1.3281	-0.9637	-0.7755	*****	*****	*****	*****	-0.7755
0.650	-1.7095	-1.5015	-1.1686	-0.9555	-0.7671	*****	*****	*****	*****	-0.7671
0.675	*****	-1.4621	-1.1146	-0.9356	-0.7461	*****	*****	*****	*****	-0.7461
0.700	-1.6793	-1.4468	-1.0805	-0.9145	-0.7409	*****	*****	*****	*****	-0.7409
0.725	*****	-1.4382	*****	-0.9093	-0.7318	*****	*****	*****	*****	-0.7318
0.750	-1.6505	-1.4388	*****	-0.8897	-0.7120	*****	*****	*****	*****	-0.7120
0.775	*****	-1.4717	-0.9794	-0.8825	-0.6947	*****	*****	*****	*****	-0.6947
0.800	-1.4561	-1.4916	-0.9678	-0.8729	*****	*****	*****	*****	*****	-0.8729
0.825	*****	-1.4371	-0.9750	-0.8683	-0.6582	*****	*****	*****	*****	-0.6582
0.850	-1.3922	-1.3819	-0.9239	-0.8673	-0.6190	*****	*****	*****	*****	-0.6190
0.875	*****	-1.3550	-0.8674	-0.8604	-0.6002	*****	*****	*****	*****	-0.6002
0.900	-1.3620	-1.3563	-0.8044	-0.8484	-0.5725	*****	*****	*****	*****	-0.5725
0.925	*****	-1.3594	-0.7607	-0.8294	-0.5618	*****	*****	*****	*****	-0.5618
0.950	-1.3236	-1.3494	-0.7321	-0.8171	-0.5141	*****	*****	*****	*****	-0.5141
0.975	*****	-1.3356	-0.7155	-0.8018	-0.4764	*****	*****	*****	*****	-0.4764
1.000	-1.3446	-1.3385	-0.7209	-0.8296	-0.4694	*****	*****	*****	*****	-0.4694
-0.200	$C_{p,l}$	$C_{p,l}$	$C_{p,l}$	$C_{p,l}$	$C_{p,l}$	$C_{p,l}$	$C_{p,l}$	$C_{p,l}$	$C_{p,l}$	$C_{p,l}$
-0.400	0.5860	0.5228	0.4822	*****	-0.5112	*****	*****	*****	*****	-0.5112
-0.600	0.5851	0.5255	0.4566	0.2501	-0.5809	*****	*****	*****	*****	-0.5809
-0.700	0.5879	0.5209	0.4528	0.2747	-0.5521	*****	*****	*****	*****	-0.5521
-0.800	0.5733	0.5155	0.4473	0.2847	-0.5201	*****	*****	*****	*****	-0.5201
-0.850	0.5281	0.4964	0.4388	0.2974	-0.4346	*****	*****	*****	*****	-0.4346
-0.900	*****	0.4651	0.4233	0.2946	-0.4184	*****	*****	*****	*****	-0.4184
-0.950	*****	0.3919	0.3725	0.2779	-0.3692	*****	*****	*****	*****	-0.3692
-0.975	0.1752	0.2056	0.2201	0.1772	-0.1454	*****	*****	*****	*****	-0.1454
-1.000	*****	-0.0499	0.0101	0.0052	-0.1345	*****	*****	*****	*****	-0.1345
	-1.3580	-1.3314	-0.7570	-0.8304	-0.5250	*****	*****	*****	*****	-0.5250

Medium Radius L.E.
 Run No. = 11, Point No. = 238
 $C_N = 1.131$, $C_m = -0.2004$
 $\alpha = 24.5^\circ$, $M_\infty = 0.850$
 $R_{mac} = 23.8 \times 10^6$

Leading Edge Pressures



x/c_R	starb'd C_p	port C_p
0.10	-1.3398	*****
0.20	-1.3446	-1.3580
0.30	-1.3758	*****
0.40	-1.3385	-1.3314
0.50	-1.3429	*****
0.60	-0.7209	-0.7570
0.70	-0.8267	*****
0.80	-0.8296	-0.8304
0.90	-0.0111	*****
0.95	-0.4694	-0.5250

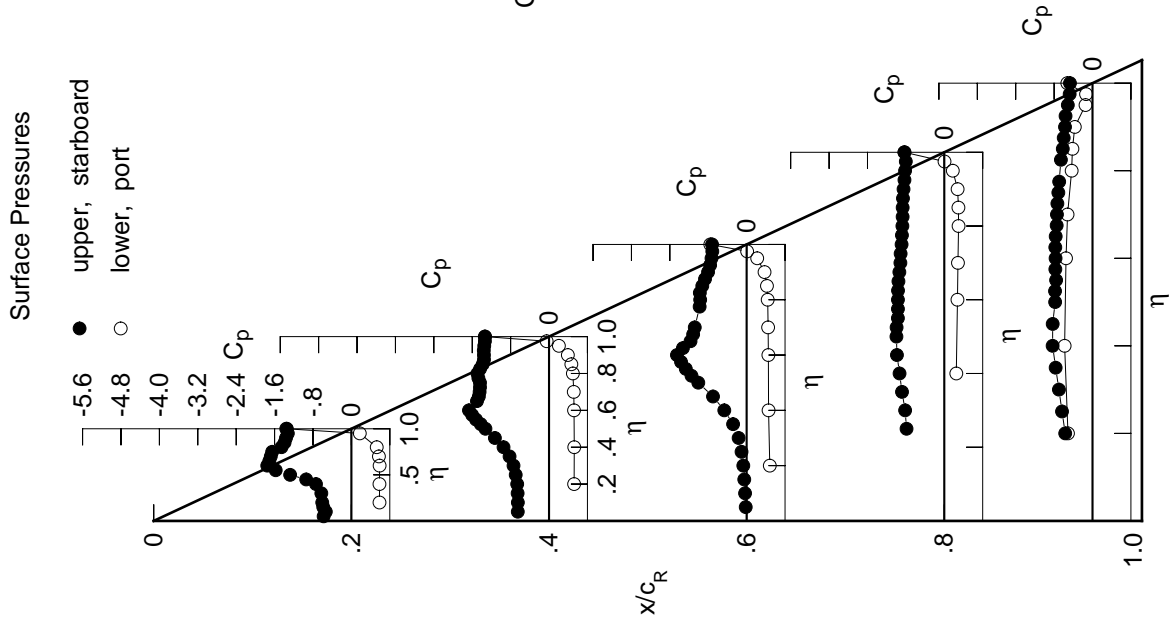
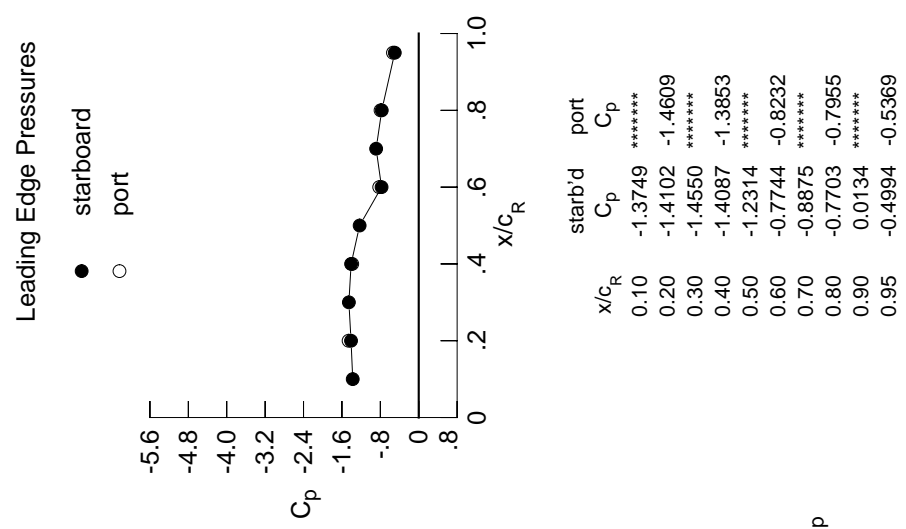

Table E3. Concluded.

η	x/c_R .2	x/c_R .4	x/c_R .6	x/c_R .8	x/c_R .95
	$C_{p,u}$	$C_{p,u}$	$C_{p,u}$	$C_{p,u}$	$C_{p,u}$
0.050	-0.6607	-0.7134	-0.0539	*****	*****
0.100	-0.6196	-0.7165	-0.0631	*****	*****
0.150	-0.6795	-0.7295	-0.0728	*****	*****
0.200	-0.6911	-0.7413	-0.0930	*****	-0.7314
0.250	*****	-0.7936	-0.1399	-1.0220	-0.8246
0.300	-0.7413	-0.8504	-0.2204	-0.9869	-0.8878
0.350	*****	-0.9574	-0.3557	-0.9370	-0.8770
0.400	-0.9815	-1.1009	-0.5618	-0.8636	-0.8116
0.450	-1.2454	-1.2830	-0.8009	-0.8289	-0.7574
0.500	-1.5102	-1.4515	-1.0657	-0.8378	-0.7384
0.525	*****	-1.5311	-1.1651	-0.8687	-0.7613
0.550	-1.7009	-1.6114	-1.2547	-0.8902	-0.7638
0.575	*****	-1.6682	-1.3036	-0.9346	-0.7826
0.600	-1.7940	-1.6870	-1.3259	-0.9566	-0.7811
0.625	*****	*****	-1.1470	-0.9561	-0.7867
0.650	-1.6725	-1.5266	-1.0343	-0.9508	-0.7811
0.675	*****	-1.5048	-0.9959	-0.9515	-0.7738
0.700	-1.6913	-1.4888	-0.9554	-0.9428	-0.7723
0.725	*****	-1.4917	*****	-0.9380	-0.7681
0.750	-1.7040	-1.4988	*****	-0.9118	-0.7521
0.775	*****	-1.5354	-0.9072	-0.9091	-0.7379
0.800	-1.4850	-1.5480	-0.8676	-0.8902	*****
0.825	*****	-1.4972	-0.8362	-0.8882	-0.7009
0.850	-1.4220	-1.4445	-0.7956	-0.8705	-0.6665
0.875	*****	-1.4173	-0.7889	-0.8541	-0.6504
0.900	-1.4053	-1.4208	-0.7812	-0.8354	-0.6241
0.925	*****	-1.4275	-0.7684	-0.8129	-0.6082
0.950	-1.3828	-1.4195	-0.7643	-0.7953	-0.5645
0.975	*****	-1.4109	-0.7615	-0.7628	-0.5217
1.000	-1.4102	-1.4087	-0.7744	-0.7703	-0.4994
	$C_{p,l}$	$C_{p,l}$	$C_{p,l}$	$C_{p,l}$	$C_{p,l}$
-0.200	0.6403	0.5739	0.5236	*****	-0.4876
-0.400	0.6425	0.5729	0.4981	0.2879	-0.5492
-0.600	0.6373	0.5669	0.4914	0.3117	-0.5253
-0.700	0.6165	0.5584	0.4849	0.3187	-0.4887
-0.800	0.5578	0.5297	0.4713	0.3262	-0.4124
-0.850	*****	0.4901	0.4478	0.3185	-0.3934
-0.900	*****	0.4016	0.3851	0.2924	-0.3445
-0.950	0.1602	0.1936	0.2134	0.1727	-0.1402
-0.975	*****	-0.0796	-0.0155	-0.0209	-0.1493
-1.000	-1.4609	-1.3853	-0.8232	-0.7955	-0.5369

Medium Radius L.E.
 Run No. = 11, Point No. = 239
 $C_N = 1.209$, $C_m = -0.2101$
 $\alpha = 26.6^\circ$, $M_\infty = 0.848$
 $R_{mac} = 23.6 \times 10^6$



x/c_R	starb'd C_p	port C_p
0.10	-1.3749	*****
0.20	-1.4102	-1.4609
0.30	-1.4550	*****
0.40	-1.4087	-1.3853
0.50	-1.2314	*****
0.60	-0.7744	-0.8232
0.70	-0.8875	*****
0.80	-0.7703	-0.7955
0.90	0.0134	*****
0.95	-0.4994	-0.5369

Table E4. Tabulations and Plots of Surface Pressure Coefficients.

η	$x/c_R = .2$		$x/c_R = .4$		$x/c_R = .6$		$x/c_R = .8$		$x/c_R = .95$	
	$C_{p,u}$	$C_{p,u}$	$C_{p,u}$	$C_{p,u}$	$C_{p,u}$	$C_{p,u}$	$C_{p,u}$	$C_{p,u}$	$C_{p,u}$	$C_{p,u}$
0.050	0.0085	0.0191	0.1443	*****	*****	*****	*****	*****	*****	*****
0.100	0.0161	0.0212	0.1329	*****	*****	*****	*****	*****	*****	*****
0.150	0.0045	0.0187	0.1223	*****	*****	*****	*****	*****	*****	*****
0.200	0.0039	0.0287	0.1087	*****	*****	*****	*****	*****	*****	*****
0.250	*****	0.0204	0.0972	-0.1172	-0.4262	*****	*****	*****	*****	*****
0.300	-0.0031	0.0224	0.0848	-0.1017	-0.5225	*****	*****	*****	*****	*****
0.350	*****	0.0165	0.0752	-0.0924	-0.5892	*****	*****	*****	*****	*****
0.400	-0.0157	0.0166	0.0705	-0.0790	-0.6076	*****	*****	*****	*****	*****
0.450	-0.0209	0.0167	0.0748	-0.0728	-0.5953	*****	*****	*****	*****	*****
0.500	-0.0245	0.0159	0.0533	-0.0660	-0.5715	*****	*****	*****	*****	*****
0.525	*****	0.0112	0.0495	-0.0680	-0.5873	*****	*****	*****	*****	*****
0.550	-0.0278	0.0047	0.0461	-0.0609	-0.5841	*****	*****	*****	*****	*****
0.575	*****	0.0056	0.0490	-0.0641	-0.6066	*****	*****	*****	*****	*****
0.600	-0.0315	0.0003	0.0367	-0.0599	-0.6147	*****	*****	*****	*****	*****
0.625	*****	*****	0.0379	-0.0554	-0.6398	*****	*****	*****	*****	*****
0.650	-0.0308	0.0001	0.0342	-0.0558	-0.6640	*****	*****	*****	*****	*****
0.675	*****	-0.0096	0.0265	-0.0554	-0.6835	*****	*****	*****	*****	*****
0.700	-0.0265	-0.0182	0.0252	-0.0549	-0.7092	*****	*****	*****	*****	*****
0.725	*****	-0.0237	*****	-0.0545	-0.7247	*****	*****	*****	*****	*****
0.750	-0.0156	-0.0304	*****	-0.0523	-0.7223	*****	*****	*****	*****	*****
0.775	*****	-0.0318	0.0054	-0.0610	-0.7038	*****	*****	*****	*****	*****
0.800	0.0014	-0.0368	0.0031	-0.0611	*****	*****	*****	*****	*****	*****
0.825	*****	-0.0329	-0.0168	-0.0618	-0.6505	*****	*****	*****	*****	*****
0.850	0.0241	-0.0298	-0.0213	-0.0770	-0.6544	*****	*****	*****	*****	*****
0.875	*****	-0.0158	-0.0272	-0.0877	-0.7412	*****	*****	*****	*****	*****
0.900	0.0613	-0.0049	-0.0236	-0.0919	-0.7750	*****	*****	*****	*****	*****
0.925	*****	0.0191	-0.0083	-0.0851	-1.1433	*****	*****	*****	*****	*****
0.950	0.1123	0.0570	0.0242	-0.0631	-0.3769	*****	*****	*****	*****	*****
0.975	*****	0.1119	0.0836	0.0097	-0.1962	*****	*****	*****	*****	*****
1.000	0.2155	0.2080	0.1790	0.1459	0.0633	*****	*****	*****	*****	*****
-0.200	$C_{p,l}$	$C_{p,l}$	$C_{p,l}$	$C_{p,l}$	$C_{p,l}$	$C_{p,l}$	$C_{p,l}$	$C_{p,l}$	$C_{p,l}$	$C_{p,l}$
-0.400	-0.0305	-0.0028	0.0818	*****	*****	*****	*****	*****	*****	*****
-0.600	-0.0532	-0.0084	0.0395	-0.1025	-0.5200	*****	*****	*****	*****	*****
-0.700	-0.0781	-0.0321	0.0104	-0.0823	-0.6047	*****	*****	*****	*****	*****
-0.800	-0.0807	-0.0654	-0.0159	-0.0846	-0.6638	*****	*****	*****	*****	*****
-0.850	-0.0690	-0.1017	-0.0604	-0.0998	-0.7168	*****	*****	*****	*****	*****
-0.900	*****	-0.1022	-0.0956	-0.1323	-0.7645	*****	*****	*****	*****	*****
-0.950	*****	-0.0920	-0.1133	-0.1716	-0.5493	*****	*****	*****	*****	*****
-0.975	0.0302	-0.0456	-0.0843	-0.1645	-0.4063	*****	*****	*****	*****	*****
-1.000	0.1960	0.1817	0.1468	0.1270	0.0546	*****	*****	*****	*****	*****

Medium Radius L.E.
 Run No. = 12, Point No. = 240
 $C_N = -0.014$, $C_m = -0.0110$
 $\alpha = -0.8^\circ$, $M_\infty = 0.850$
 $R_{mac} = 35.9 \times 10^6$

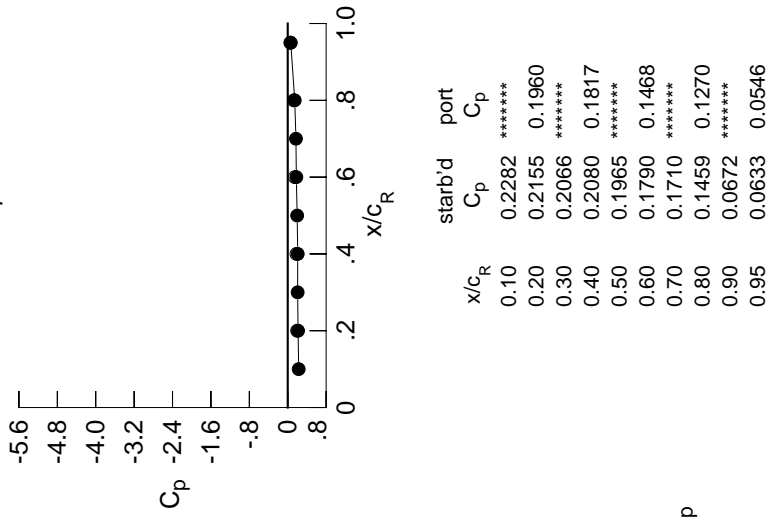
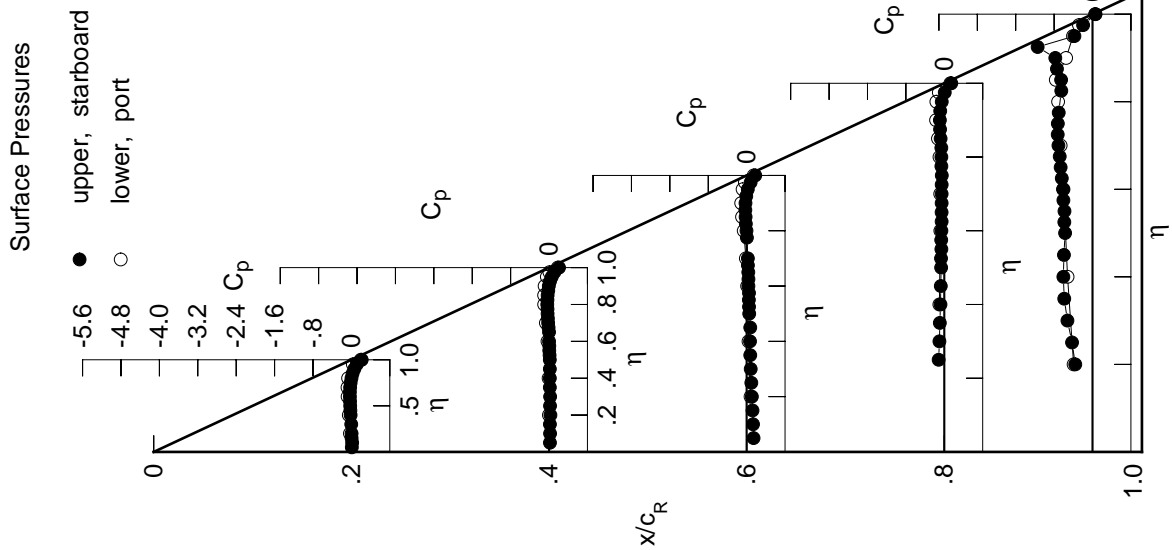
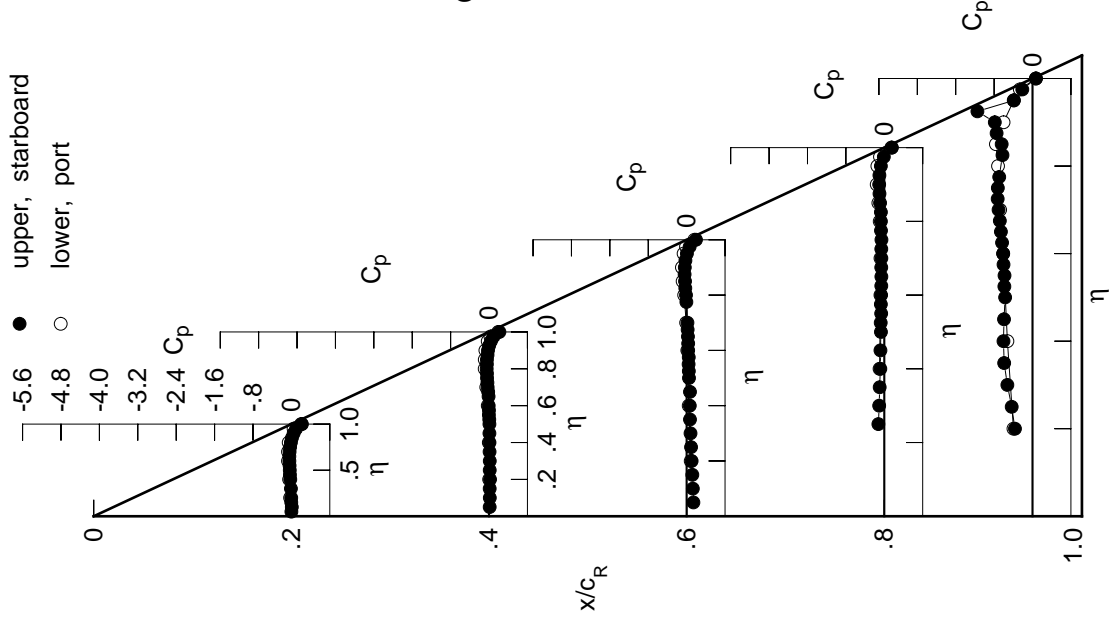

Table E4. Continued.

η	x/c_R .2	x/c_R .4	x/c_R .6	x/c_R .8	x/c_R .95
	$C_{p,u}$	$C_{p,u}$	$C_{p,u}$	$C_{p,u}$	$C_{p,u}$
0.050	0.0004	0.0139	0.1408	*****	*****
0.100	0.0088	0.0156	0.1287	*****	*****
0.150	-0.0027	0.0133	0.1186	*****	*****
0.200	-0.0033	0.0212	0.1044	*****	-0.3656
0.250	*****	0.0146	0.0919	-0.1228	-0.4334
0.300	-0.0097	0.0153	0.0809	-0.1062	-0.5240
0.350	*****	0.0113	0.0698	-0.0962	-0.5906
0.400	-0.0232	0.0099	0.0657	-0.0825	-0.6050
0.450	-0.0301	0.0082	0.0696	-0.0796	-0.5937
0.500	-0.0339	0.0079	0.0485	-0.0699	-0.5705
0.525	*****	0.0045	0.0453	-0.0744	-0.5863
0.550	-0.0375	-0.0030	0.0408	-0.0652	-0.5833
0.575	*****	-0.0014	0.0442	-0.0710	-0.6042
0.600	-0.0420	-0.0074	0.0318	-0.0665	-0.6115
0.625	*****	*****	0.0319	-0.0622	-0.6345
0.650	-0.0422	-0.0099	0.0268	-0.0611	-0.6587
0.675	*****	-0.0178	0.0204	-0.0630	-0.6805
0.700	-0.0379	-0.0291	0.0166	-0.0611	-0.7073
0.725	*****	-0.0339	*****	-0.0627	-0.7253
0.750	-0.0274	-0.0414	*****	-0.0590	-0.7223
0.775	*****	-0.0435	-0.0056	-0.0691	-0.6939
0.800	-0.0107	-0.0490	-0.0137	-0.0706	*****
0.825	*****	-0.0451	-0.0280	-0.0703	-0.6254
0.850	0.0109	-0.0444	-0.0336	-0.0882	-0.6428
0.875	*****	-0.0314	-0.0422	-0.1004	-0.7482
0.900	0.0472	-0.0214	-0.0387	-0.1064	-0.7853
0.925	*****	0.0009	-0.0259	-0.1017	-1.1479
0.950	0.0980	0.0397	0.0052	-0.0709	-0.3879
0.975	*****	0.0937	0.0630	-0.0098	-0.2129
1.000	0.2191	0.2161	0.1944	0.1586	0.0727
	$C_{p,l}$	$C_{p,l}$	$C_{p,l}$	$C_{p,l}$	$C_{p,l}$
-0.200	-0.0262	0.0022	0.0847	*****	-0.3971
-0.400	-0.0476	-0.0046	0.0430	-0.0987	-0.5231
-0.600	-0.0703	-0.0263	0.0144	-0.0796	-0.6107
-0.700	-0.0707	-0.0575	-0.0102	-0.0792	-0.6753
-0.800	-0.0562	-0.0901	-0.0514	-0.0952	-0.7187
-0.850	*****	-0.0891	-0.0833	-0.1233	-0.7622
-0.900	*****	-0.0761	-0.0980	-0.1579	-0.6035
-0.950	0.0455	-0.0270	-0.0632	-0.1441	-0.3909
-0.975	*****	0.0294	-0.0129	-0.0893	-0.2640
-1.000	0.2022	0.1930	0.1625	0.1470	0.0688

Surface Pressures



Medium Radius L.E.
 Run No. = 12, Point No. = 241
 $C_N = -0.002$, $C_m = -0.0120$
 $\alpha = -0.5^\circ$, $M_\infty = 0.851$
 $R_{mac} = 36.0 \times 10^6$

Leading Edge Pressures

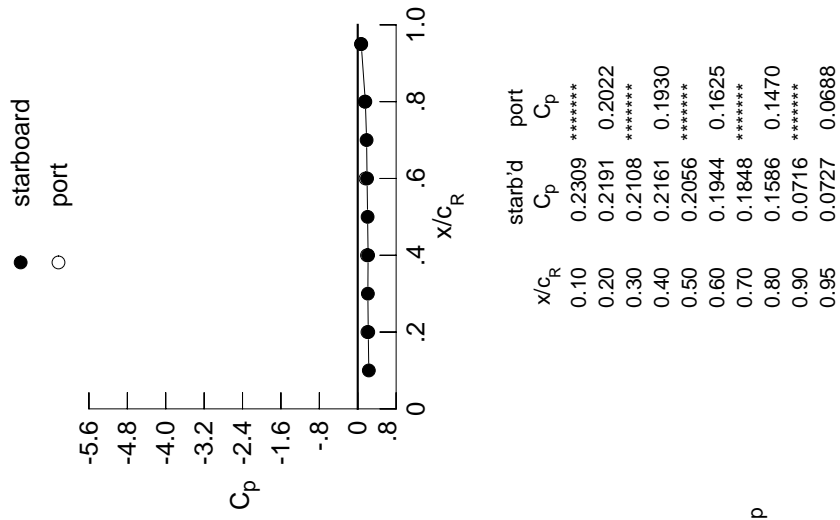

Table E4. Continued.

η	$x/c_R = .2$		$x/c_R = .4$		$x/c_R = .6$		$x/c_R = .8$		$x/c_R = .95$	
	$C_{p,u}$	$C_{p,u}$	$C_{p,u}$	$C_{p,u}$	$C_{p,u}$	$C_{p,u}$	$C_{p,u}$	$C_{p,u}$	$C_{p,u}$	$C_{p,u}$
0.050	-0.0201	-0.0030	0.1281	*****	*****	*****	*****	*****	*****	
0.100	-0.0114	-0.0023	0.1175	*****	*****	*****	*****	*****	*****	
0.150	-0.0209	-0.0027	0.1063	*****	*****	*****	*****	*****	*****	
0.200	-0.0238	0.0040	0.0922	*****	*****	*****	*****	*****	-0.3414	
0.250	*****	-0.0034	0.0807	-0.1324	-0.1924	-0.4003	*****	*****	*****	
0.300	-0.0301	-0.0007	0.0657	-0.1192	-0.4920	*****	*****	*****	*****	
0.350	*****	-0.0082	0.0592	-0.1068	-0.5854	*****	*****	*****	*****	
0.400	-0.0481	-0.0063	0.0489	-0.0973	-0.6344	*****	*****	*****	*****	
0.450	-0.0535	-0.0137	0.0566	-0.0891	-0.6231	*****	*****	*****	*****	
0.500	-0.0583	-0.0094	0.0303	-0.0843	-0.6019	*****	*****	*****	*****	
0.525	*****	-0.0197	0.0295	-0.0861	-0.6110	*****	*****	*****	*****	
0.550	-0.0635	-0.0213	0.0230	-0.0809	-0.6080	*****	*****	*****	*****	
0.575	*****	-0.0268	0.0276	-0.0834	-0.6251	*****	*****	*****	*****	
0.600	-0.0706	-0.0293	0.0131	-0.0825	-0.6372	*****	*****	*****	*****	
0.625	*****	*****	0.0137	-0.0784	-0.6567	*****	*****	*****	*****	
0.650	-0.0729	-0.0326	0.0083	-0.0786	-0.6821	*****	*****	*****	*****	
0.675	*****	-0.0465	-0.0021	-0.0779	-0.6984	*****	*****	*****	*****	
0.700	-0.0713	-0.0549	-0.0026	-0.0805	-0.7188	*****	*****	*****	*****	
0.725	*****	-0.0651	*****	-0.0795	-0.7179	*****	*****	*****	*****	
0.750	-0.0625	-0.0719	*****	-0.0815	-0.6554	*****	*****	*****	*****	
0.775	*****	-0.0798	-0.0291	-0.0900	-0.5187	*****	*****	*****	*****	
0.800	-0.0493	-0.0860	-0.0452	-0.0956	*****	*****	*****	*****	*****	
0.825	*****	-0.0878	-0.0615	-0.0949	-0.4617	*****	*****	*****	*****	
0.850	-0.0290	-0.0866	-0.0754	-0.1206	-0.5409	*****	*****	*****	*****	
0.875	*****	-0.0787	-0.0839	-0.1362	-0.7635	*****	*****	*****	*****	
0.900	0.0045	-0.0723	-0.0902	-0.1524	-0.8103	*****	*****	*****	*****	
0.925	*****	-0.0531	-0.0809	-0.1532	-1.1694	*****	*****	*****	*****	
0.950	0.0531	-0.0199	-0.0572	-0.1311	-0.4215	*****	*****	*****	*****	
0.975	*****	0.0346	-0.0035	-0.0795	-0.2668	*****	*****	*****	*****	
1.000	0.2191	0.2149	0.2084	0.1619	0.0751	*****	*****	*****	*****	
-0.200	$C_{p,l}$	$C_{p,l}$	$C_{p,l}$	$C_{p,l}$	$C_{p,l}$	$C_{p,l}$	$C_{p,l}$	$C_{p,l}$	$C_{p,l}$	
-0.400	-0.0028	0.0189	0.0988	*****	*****	-0.4199	*****	*****	*****	
-0.600	-0.0246	0.0185	0.0582	-0.0868	-0.6019	*****	*****	*****	*****	
-0.700	-0.0412	-0.0021	0.0344	-0.0610	-0.6784	*****	*****	*****	*****	
-0.800	-0.0366	-0.0273	0.0130	-0.0628	-0.7117	*****	*****	*****	*****	
-0.850	-0.0169	-0.0513	-0.0203	-0.0670	-0.7122	*****	*****	*****	*****	
-0.900	*****	-0.0423	-0.0435	-0.0897	-0.7413	*****	*****	*****	*****	
-0.950	*****	-0.0238	-0.0466	-0.1120	-0.7945	*****	*****	*****	*****	
-0.975	0.0943	0.0328	-0.0005	-0.0808	-0.3550	*****	*****	*****	*****	
-1.000	*****	0.0923	0.0575	-0.0172	-0.2109	*****	*****	*****	*****	
	0.2074	0.2014	0.1749	0.1671	0.0858	*****	*****	*****	*****	

Medium Radius L.E.
 Run No. = 12, Point No. = 242
 $C_N = 0.040$, $C_m = -0.0202$
 $\alpha = 0.6^\circ$, $M_\infty = 0.850$
 $R_{mac} = 36.2 \times 10^6$

Leading Edge Pressures

● starboard
 ○ port

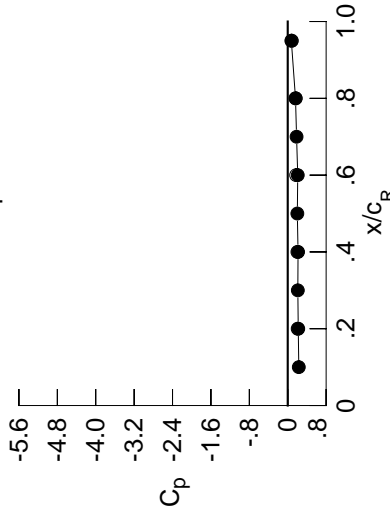

x/c_R	starb'd C_p	port C_p
0.10	0.2307	*****
0.20	0.2191	0.2074
0.30	0.2103	*****
0.40	0.2149	0.2014
0.50	0.1999	*****
0.60	0.2084	0.1749
0.70	0.1841	*****
0.80	0.1619	0.1671
0.90	0.0713	*****
0.95	0.0751	0.0858

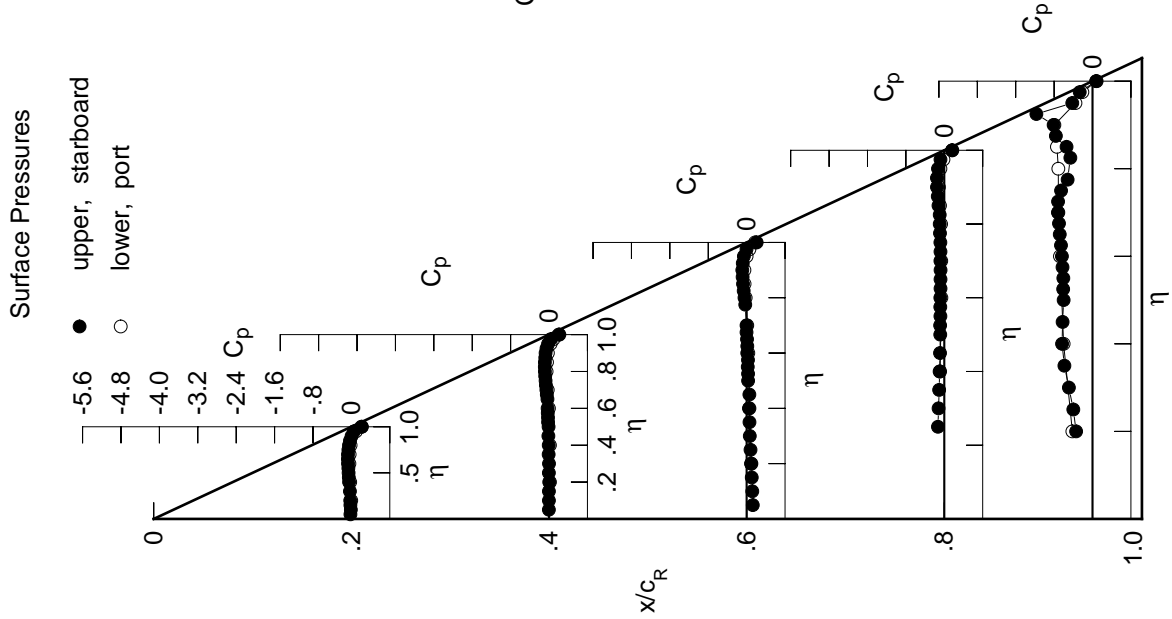

Table E4. Continued.

η	$x/c_R = .2$		$x/c_R = .4$		$x/c_R = .6$		$x/c_R = .8$		$x/c_R = .95$	
	$C_{p,u}$	$C_{p,u}$	$C_{p,u}$	$C_{p,u}$	$C_{p,u}$	$C_{p,u}$	$C_{p,u}$	$C_{p,u}$	$C_{p,u}$	$C_{p,u}$
0.050	-0.0383	-0.0194	0.1146	0.1146	0.1146	0.1146	0.1146	0.1146	0.1146	0.1146
0.100	-0.0315	-0.0186	0.1034	0.1034	0.1034	0.1034	0.1034	0.1034	0.1034	0.1034
0.150	-0.0404	-0.0211	0.0944	0.0944	0.0944	0.0944	0.0944	0.0944	0.0944	0.0944
0.200	-0.0438	-0.0127	0.0788	0.0788	0.0788	0.0788	0.0788	0.0788	0.0788	0.0788
0.250	*****	-0.0224	0.0664	0.0664	-0.1445	-0.1445	-0.3754	-0.3754	-0.3244	-0.3244
0.300	-0.0510	-0.0190	0.0521	-0.1323	-0.4489	-0.4489	-0.5276	-0.5276	-0.3754	-0.3754
0.350	*****	-0.0275	0.0445	-0.1202	-0.5276	-0.5276	-0.5276	-0.5276	-0.5276	-0.5276
0.400	-0.0685	-0.0250	0.0342	-0.1105	-0.5811	-0.5811	-0.5811	-0.5811	-0.5811	-0.5811
0.450	-0.0776	-0.0337	0.0393	-0.1029	-0.5794	-0.5794	-0.5794	-0.5794	-0.5794	-0.5794
0.500	-0.0844	-0.0305	0.0146	-0.0990	-0.5592	-0.5592	-0.5592	-0.5592	-0.5592	-0.5592
0.525	*****	-0.0405	0.0113	-0.0997	-0.5695	-0.5695	-0.5695	-0.5695	-0.5695	-0.5695
0.550	-0.0916	-0.0454	0.0068	-0.0952	-0.5658	-0.5658	-0.5658	-0.5658	-0.5658	-0.5658
0.575	*****	-0.0486	0.0080	-0.0993	-0.5862	-0.5862	-0.5862	-0.5862	-0.5862	-0.5862
0.600	-0.1010	-0.0537	-0.0045	-0.0968	-0.6015	-0.6015	-0.6015	-0.6015	-0.6015	-0.6015
0.625	*****	*****	-0.0077	-0.0951	-0.6312	-0.6312	-0.6312	-0.6312	-0.6312	-0.6312
0.650	-0.1051	-0.0590	-0.0125	-0.0966	-0.6645	-0.6645	-0.6645	-0.6645	-0.6645	-0.6645
0.675	*****	-0.0741	-0.0244	-0.0972	-0.6776	-0.6776	-0.6776	-0.6776	-0.6776	-0.6776
0.700	-0.1076	-0.0867	-0.0264	-0.1001	-0.6741	-0.6741	-0.6741	-0.6741	-0.6741	-0.6741
0.725	*****	-0.0990	*****	-0.1008	-0.6135	-0.6135	-0.6135	-0.6135	-0.6135	-0.6135
0.750	-0.1007	-0.1070	*****	-0.1040	-0.4845	-0.4845	-0.4845	-0.4845	-0.4845	-0.4845
0.775	*****	-0.1178	-0.0604	-0.1160	-0.3570	-0.3570	-0.3570	-0.3570	-0.3570	-0.3570
0.800	-0.0912	-0.1276	-0.0786	-0.1230	*****	*****	*****	*****	*****	*****
0.825	*****	-0.1333	-0.0999	-0.1253	-0.3583	-0.3583	-0.3583	-0.3583	-0.3583	-0.3583
0.850	-0.0734	-0.1375	-0.1179	-0.1553	-0.4175	-0.4175	-0.4175	-0.4175	-0.4175	-0.4175
0.875	*****	-0.1325	-0.1352	-0.1794	-0.6947	-0.6947	-0.6947	-0.6947	-0.6947	-0.6947
0.900	-0.0444	-0.1302	-0.1465	-0.2018	-0.7852	-0.7852	-0.7852	-0.7852	-0.7852	-0.7852
0.925	*****	-0.1176	-0.1461	-0.2148	-1.1825	-1.1825	-1.1825	-1.1825	-1.1825	-1.1825
0.950	-0.0021	-0.0898	-0.1307	-0.2027	-0.4625	-0.4625	-0.4625	-0.4625	-0.4625	-0.4625
0.975	*****	-0.0432	-0.0887	-0.1662	-0.3310	-0.3310	-0.3310	-0.3310	-0.3310	-0.3310
1.000	0.1917	0.1647	0.1408	0.0910	0.0231	0.0231	0.0231	0.0231	0.0231	0.0231
-0.200	$C_{p,l}$	$C_{p,l}$	$C_{p,l}$	$C_{p,l}$	$C_{p,l}$	$C_{p,l}$	$C_{p,l}$	$C_{p,l}$	$C_{p,l}$	$C_{p,l}$
-0.400	0.0160	0.0358	0.1119	*****	-0.4416	-0.4416	-0.4416	-0.4416	-0.4416	-0.4416
-0.600	-0.0010	0.0376	0.0750	-0.0738	-0.6173	-0.6173	-0.6173	-0.6173	-0.6173	-0.6173
-0.700	-0.0116	0.0195	0.0522	-0.0453	-0.6856	-0.6856	-0.6856	-0.6856	-0.6856	-0.6856
-0.800	-0.0033	0.0009	0.0351	-0.0443	-0.7191	-0.7191	-0.7191	-0.7191	-0.7191	-0.7191
-0.850	0.0205	-0.0134	0.0107	-0.0421	-0.6975	-0.6975	-0.6975	-0.6975	-0.6975	-0.6975
-0.900	*****	0.0002	-0.0051	-0.0578	-0.7189	-0.7189	-0.7189	-0.7189	-0.7189	-0.7189
-0.950	*****	0.0260	0.0009	-0.0674	-0.7784	-0.7784	-0.7784	-0.7784	-0.7784	-0.7784
-0.975	0.1354	0.0842	0.0555	-0.0233	-0.3243	-0.3243	-0.3243	-0.3243	-0.3243	-0.3243
-1.000	*****	0.1436	0.1141	0.0438	-0.1648	-0.1648	-0.1648	-0.1648	-0.1648	-0.1648
-1.000	0.1843	0.1615	0.1180	0.1125	0.0479	0.0479	0.0479	0.0479	0.0479	0.0479

Medium Radius L.E.
 Run No. = 12, Point No. = 243
 $C_N = 0.079$, $C_m = -0.0254$
 $\alpha = 1.6^\circ$, $M_\infty = 0.850$
 $R_{mac} = 36.3 \times 10^6$

Leading Edge Pressures

● starboard
 ○ port

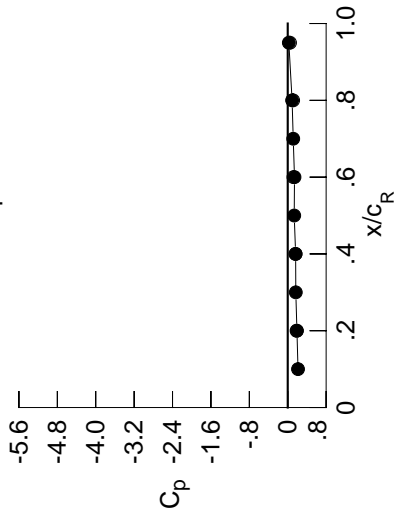

x/c_R	starb'd C_p	port C_p
0.10	0.2142	*****
0.20	0.1917	0.1843
0.30	0.1682	*****
0.40	0.1647	0.1615
0.50	0.1352	*****
0.60	0.1408	0.1180
0.70	0.1145	*****
0.80	0.0910	0.1125
0.90	0.0650	*****
0.95	0.0231	0.0479

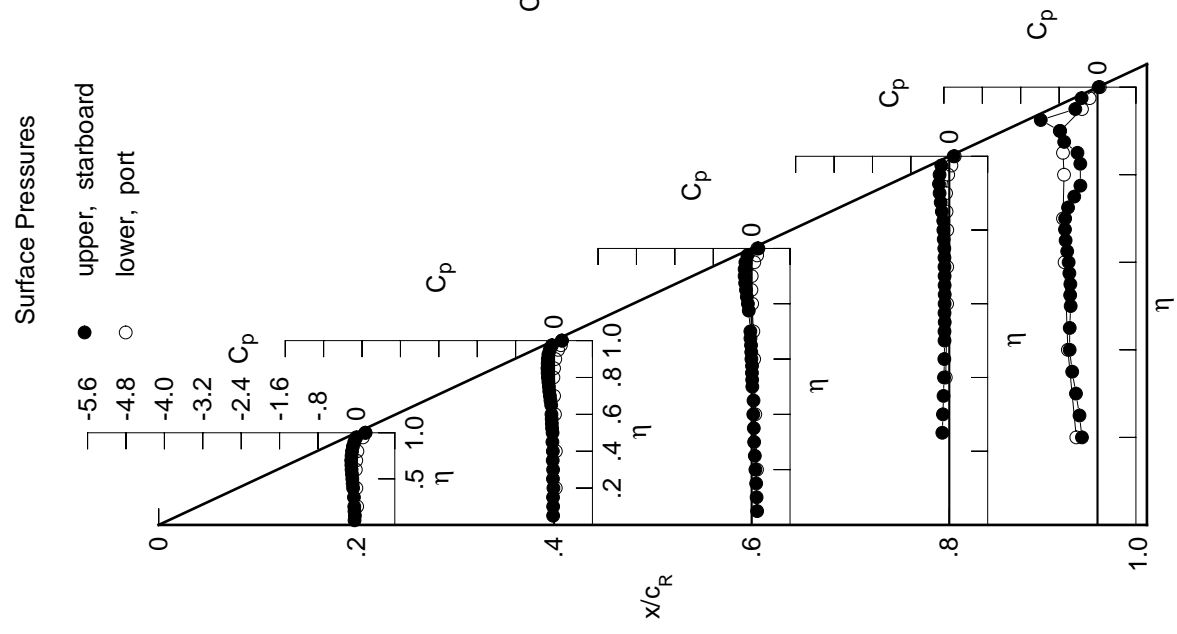

Table E4. Continued.

η	$x/c_R = .2$		$x/c_R = .4$		$x/c_R = .6$		$x/c_R = .8$		$x/c_R = .95$	
	$C_{p,u}$	$C_{p,u}$	$C_{p,u}$	$C_{p,u}$	$C_{p,u}$	$C_{p,u}$	$C_{p,u}$	$C_{p,u}$	$C_{p,u}$	$C_{p,u}$
0.050	-0.0584	-0.0364	0.1025	*****	0.1025	*****	0.1025	*****	0.1025	*****
0.100	-0.0504	-0.0366	0.0932	*****	0.0932	*****	0.0932	*****	0.0932	*****
0.150	-0.0602	-0.0373	0.0810	*****	0.0810	*****	0.0810	*****	0.0810	*****
0.200	-0.0620	-0.0318	0.0668	*****	0.0668	*****	0.0668	*****	0.0668	*****
0.250	*****	-0.0387	0.0504	-0.1576	0.0504	-0.1576	0.0504	-0.1576	0.0504	-0.3291
0.300	-0.0700	-0.0375	0.0404	-0.1430	0.0404	-0.1430	0.0404	-0.1430	0.0404	-0.4227
0.350	*****	-0.0448	0.0302	-0.1329	0.0302	-0.1329	0.0302	-0.1329	0.0302	-0.4983
0.400	-0.0915	-0.0454	0.0204	-0.1218	0.0204	-0.1218	0.0204	-0.1218	0.0204	-0.5621
0.450	-0.1007	-0.0528	0.0246	-0.1168	0.0246	-0.1168	0.0246	-0.1168	0.0246	-0.5752
0.500	-0.1098	-0.0533	-0.0006	-0.1127	-0.1127	-0.1127	-0.1127	-0.1127	-0.1127	-0.5644
0.525	*****	-0.0612	-0.0050	-0.1136	-0.1136	-0.1136	-0.1136	-0.1136	-0.1136	-0.5823
0.550	-0.1196	-0.0677	-0.0137	-0.1108	-0.1108	-0.1108	-0.1108	-0.1108	-0.1108	-0.5839
0.575	*****	-0.0729	-0.0086	-0.1136	-0.1136	-0.1136	-0.1136	-0.1136	-0.1136	-0.6109
0.600	-0.1305	-0.0787	-0.0250	-0.1144	-0.1144	-0.1144	-0.1144	-0.1144	-0.1144	-0.6340
0.625	*****	*****	-0.0259	-0.1098	-0.1098	-0.1098	-0.1098	-0.1098	-0.1098	-0.6627
0.650	-0.1383	-0.0875	-0.0335	-0.1123	-0.1123	-0.1123	-0.1123	-0.1123	-0.1123	-0.6795
0.675	*****	-0.1026	-0.0450	-0.1155	-0.1155	-0.1155	-0.1155	-0.1155	-0.1155	-0.6548
0.700	-0.1440	-0.1178	-0.0505	-0.1191	-0.1191	-0.1191	-0.1191	-0.1191	-0.1191	-0.5851
0.725	*****	-0.1313	*****	-0.1228	-0.1228	-0.1228	-0.1228	-0.1228	-0.1228	-0.4748
0.750	-0.1412	-0.1441	*****	-0.1266	-0.1266	-0.1266	-0.1266	-0.1266	-0.1266	-0.3653
0.775	*****	-0.1580	-0.0910	-0.1400	-0.1400	-0.1400	-0.1400	-0.1400	-0.1400	-0.2634
0.800	-0.1346	-0.1708	-0.1127	-0.1516	-0.1516	-0.1516	-0.1516	-0.1516	-0.1516	*****
0.825	*****	-0.1806	-0.1401	-0.1552	-0.1552	-0.1552	-0.1552	-0.1552	-0.1552	-0.2922
0.850	-0.1212	-0.1879	-0.1632	-0.1923	-0.1923	-0.1923	-0.1923	-0.1923	-0.1923	-0.3206
0.875	*****	-0.1915	-0.1876	-0.2228	-0.2228	-0.2228	-0.2228	-0.2228	-0.2228	-0.5079
0.900	-0.0976	-0.1913	-0.2084	-0.2576	-0.2576	-0.2576	-0.2576	-0.2576	-0.2576	-0.6864
0.925	*****	-0.1885	-0.2170	-0.2784	-0.2784	-0.2784	-0.2784	-0.2784	-0.2784	-1.1482
0.950	-0.0632	-0.1651	-0.2138	-0.2846	-0.2846	-0.2846	-0.2846	-0.2846	-0.2846	-0.5114
0.975	*****	-0.1355	-0.1870	-0.2648	-0.2648	-0.2648	-0.2648	-0.2648	-0.2648	-0.4059
1.000	0.1346	0.0668	0.0158	-0.0544	-0.0544	-0.0544	-0.0544	-0.0544	-0.0544	-0.0846
	$C_{p,l}$	$C_{p,l}$	$C_{p,l}$	$C_{p,l}$	$C_{p,l}$	$C_{p,l}$	$C_{p,l}$	$C_{p,l}$	$C_{p,l}$	$C_{p,l}$
-0.200	0.0373	0.0568	0.1264	*****	0.1264	*****	0.1264	*****	0.1264	-0.4596
-0.400	0.0214	0.0571	0.0873	-0.0591	-0.0591	-0.0591	-0.0591	-0.0591	-0.0591	-0.6749
-0.600	0.0171	0.0433	0.0711	-0.0313	-0.0313	-0.0313	-0.0313	-0.0313	-0.0313	-0.7303
-0.700	0.0279	0.0279	0.0559	-0.0258	-0.0258	-0.0258	-0.0258	-0.0258	-0.0258	-0.7272
-0.800	0.0569	0.0225	0.0392	-0.0200	-0.0200	-0.0200	-0.0200	-0.0200	-0.0200	-0.6816
-0.850	*****	0.0395	0.0306	-0.0287	-0.0287	-0.0287	-0.0287	-0.0287	-0.0287	-0.6980
-0.900	*****	0.0693	0.0425	-0.0279	-0.0279	-0.0279	-0.0279	-0.0279	-0.0279	-0.7369
-0.950	0.1687	0.1278	0.1024	0.0245	0.0245	0.0245	0.0245	0.0245	0.0245	-0.2970
-0.975	*****	0.1819	0.1563	0.0893	-0.1266	-0.1266	-0.1266	-0.1266	-0.1266	-0.1266
-1.000	0.1338	0.0721	-0.0116	-0.0135	-0.0135	-0.0135	-0.0135	-0.0135	-0.0135	-0.0393

Medium Radius L.E.
 Run No. = 12, Point No. = 244
 $C_N = 0.119$, $C_m = -0.0311$
 $\alpha = 2.7^\circ$, $M_\infty = 0.850$
 $R_{mac} = 36.4 \times 10^6$

Leading Edge Pressures

● starboard
 ○ port

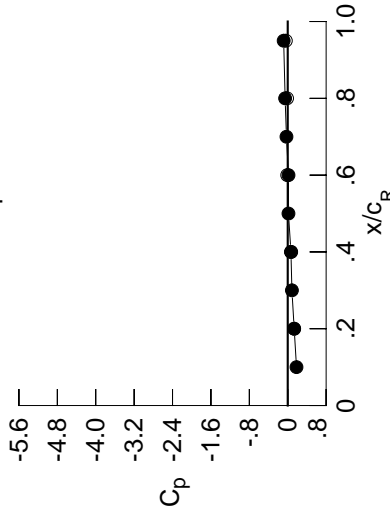

x/c_R	starb'd C_p	port C_p
0.10	0.1827	*****
0.20	0.1346	0.1338
0.30	0.0872	*****
0.40	0.0668	0.0721
0.50	0.0154	*****
0.60	0.0158	-0.0116
0.70	-0.0267	*****
0.80	-0.0544	-0.0135
0.90	0.0498	*****
0.95	-0.0846	-0.0393

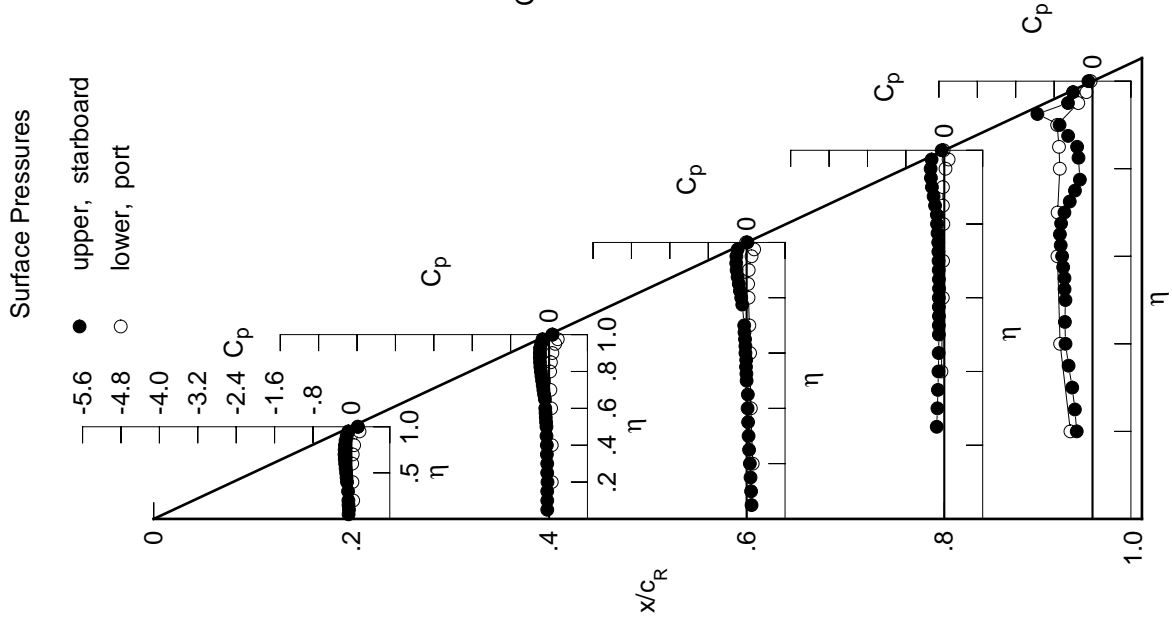

Table E4. Continued.

η	$x/c_R = .2$		$x/c_R = .4$		$x/c_R = .6$		$x/c_R = .8$		$x/c_R = .95$	
	$C_{p,u}$	$C_{p,l}$	$C_{p,u}$	$C_{p,l}$	$C_{p,u}$	$C_{p,l}$	$C_{p,u}$	$C_{p,l}$	$C_{p,u}$	$C_{p,l}$
0.050	-0.0765	-0.0525	0.0911	*****	0.0911	*****	0.0911	*****	0.0911	*****
0.100	-0.0697	-0.0535	0.0806	*****	0.0806	*****	0.0806	*****	0.0806	*****
0.150	-0.0786	-0.0551	0.0680	*****	0.0680	*****	0.0680	*****	0.0680	*****
0.200	-0.0820	-0.0492	0.0543	*****	0.0543	*****	0.0543	*****	0.0543	*****
0.250	*****	-0.0567	0.0390	-0.1696	-0.1696	-0.3519	0.0390	-0.1696	-0.3519	0.0390
0.300	-0.0899	-0.0557	0.0271	-0.1549	-0.1549	-0.3914	0.0271	-0.1549	-0.3914	0.0271
0.350	*****	-0.0626	0.0150	-0.1457	-0.1457	-0.4518	0.0150	-0.1457	-0.4518	0.0150
0.400	-0.1135	-0.0656	0.0049	-0.1337	-0.1337	-0.5164	0.0049	-0.1337	-0.5164	0.0049
0.450	-0.1274	-0.0724	0.0086	-0.1306	-0.1306	-0.5461	0.0086	-0.1306	-0.5461	0.0086
0.500	-0.1357	-0.0737	-0.0185	-0.1262	-0.1262	-0.5466	-0.0185	-0.1262	-0.5466	-0.0185
0.525	*****	-0.0834	-0.0225	-0.1291	-0.1291	-0.5661	-0.0225	-0.1291	-0.5661	-0.0225
0.550	-0.1477	-0.0919	-0.0312	-0.1244	-0.1244	-0.5667	-0.0312	-0.1244	-0.5667	-0.0312
0.575	*****	-0.0967	-0.0276	-0.1309	-0.1309	-0.5912	-0.0276	-0.1309	-0.5912	-0.0276
0.600	-0.1616	-0.1044	-0.0453	-0.1304	-0.1304	-0.6097	-0.0453	-0.1304	-0.6097	-0.0453
0.625	*****	*****	-0.0462	-0.1269	-0.1269	-0.6251	-0.0462	-0.1269	-0.6251	-0.0462
0.650	-0.1725	-0.1136	-0.0565	-0.1310	-0.1310	-0.6203	-0.0565	-0.1310	-0.6203	-0.0565
0.675	*****	-0.1328	-0.0681	-0.1358	-0.1358	-0.5622	-0.0681	-0.1358	-0.5622	-0.0681
0.700	-0.1807	-0.1481	-0.0757	-0.1399	-0.1399	-0.4758	-0.0757	-0.1399	-0.4758	-0.0757
0.725	*****	-0.1655	*****	-0.1450	-0.1450	-0.3949	-0.1450	-0.1450	-0.3949	-0.1450
0.750	-0.1824	-0.1816	*****	-0.1507	-0.1507	-0.3104	-0.1507	-0.1507	-0.3104	-0.1507
0.775	*****	-0.1989	-0.1245	-0.1684	-0.1684	-0.2246	-0.1245	-0.1684	-0.2246	-0.1245
0.800	-0.1804	-0.2168	-0.1482	-0.1817	-0.1817	*****	-0.1482	-0.1817	*****	-0.1482
0.825	*****	-0.2312	-0.1808	-0.1877	-0.1877	-0.2621	-0.1808	-0.1877	-0.2621	-0.1808
0.850	-0.1723	-0.2441	-0.2102	-0.2300	-0.2300	-0.2794	-0.2102	-0.2300	-0.2794	-0.2102
0.875	*****	-0.2537	-0.2447	-0.2686	-0.2686	-0.4050	-0.2447	-0.2686	-0.4050	-0.2447
0.900	-0.1578	-0.2599	-0.2756	-0.3145	-0.3145	-0.6056	-0.2756	-0.3145	-0.6056	-0.2756
0.925	*****	-0.2661	-0.2955	-0.3503	-0.3503	-0.9880	-0.2955	-0.3503	-0.9880	-0.2955
0.950	-0.1317	-0.2520	-0.3088	-0.3754	-0.3754	-0.5643	-0.3088	-0.3754	-0.5643	-0.3088
0.975	*****	-0.2432	-0.3042	-0.3805	-0.3805	-0.4963	-0.3042	-0.3805	-0.4963	-0.3042
1.000	0.0501	-0.0822	-0.1561	-0.2705	-0.2705	-0.2485	-0.1561	-0.2705	-0.2485	-0.1561
-0.200	0.0584	0.0746	0.1399	*****	0.1399	*****	0.1399	*****	0.1399	*****
-0.400	0.0450	0.0765	0.1026	-0.0449	-0.0449	-0.7038	0.1026	-0.0449	-0.7038	0.1026
-0.600	0.0458	0.0658	0.0893	-0.0168	-0.0168	-0.7339	0.0893	-0.0168	-0.7339	0.0893
-0.700	0.0599	0.0557	0.0756	-0.0070	-0.0070	-0.7163	0.0756	-0.0070	-0.7163	0.0756
-0.800	0.0910	0.0564	0.0669	0.0020	0.0020	-0.6643	0.0669	0.0020	-0.6643	0.0669
-0.850	*****	0.0762	0.0643	0.0012	0.0012	-0.6762	0.0643	0.0012	-0.6762	0.0643
-0.900	*****	0.1087	0.0826	0.0079	0.0079	-0.6967	0.0826	0.0079	-0.6967	0.0826
-0.950	0.1975	0.1634	0.1415	0.0662	0.0662	-0.2734	0.1415	0.0662	-0.2734	0.1415
-0.975	*****	0.2065	0.1858	0.1239	0.1239	-0.0971	0.1858	0.1239	-0.0971	0.1858
-1.000	0.0504	-0.0649	-0.2124	-0.2142	-0.2142	-0.1777	-0.2124	-0.2142	-0.1777	-0.2124

Medium Radius L.E.
 Run No. = 12, Point No. = 245
 $C_N = 0.162$, $C_m = -0.0383$
 $\alpha = 3.8^\circ$, $M_\infty = 0.850$
 $R_{mac} = 36.5 \times 10^6$

Leading Edge Pressures

● starboard
 ○ port

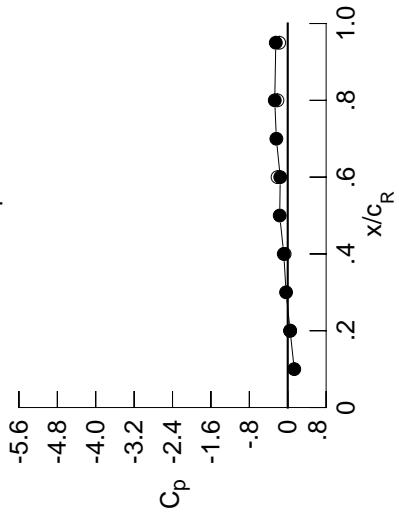

x/c_R	starb'd C_p	port C_p
0.10	0.1357	*****
0.20	0.0501	0.0504
0.30	-0.0344	*****
0.40	-0.0822	-0.0649
0.50	-0.1673	*****
0.60	-0.1561	-0.2124
0.70	-0.2370	*****
0.80	-0.2705	-0.2142
0.90	0.0244	*****
0.95	-0.2485	-0.1777

Surface Pressures
 ● upper, starboard
 ○ lower, port

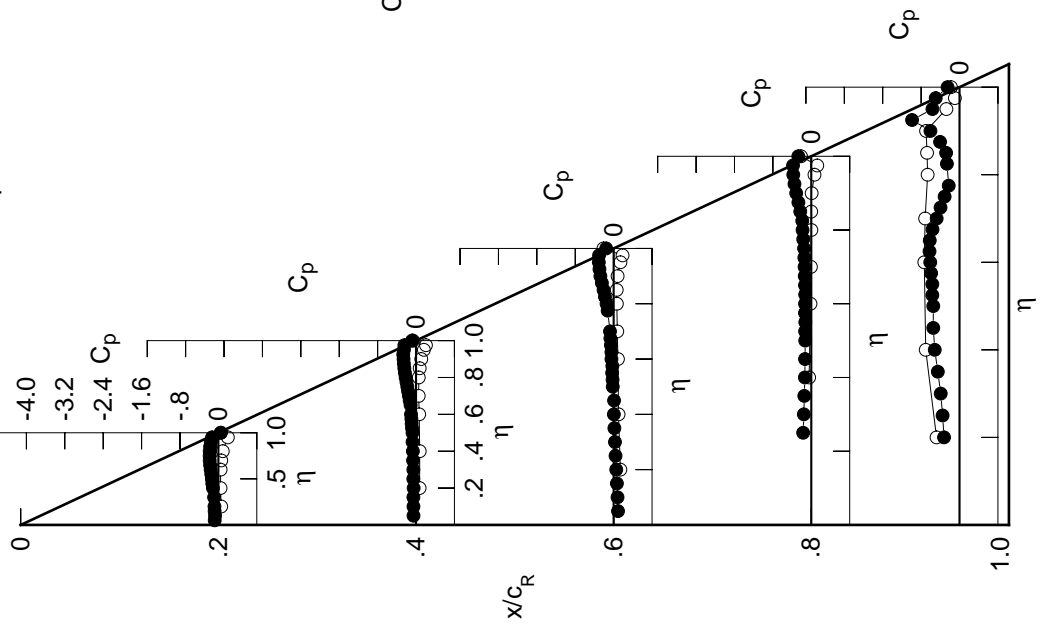
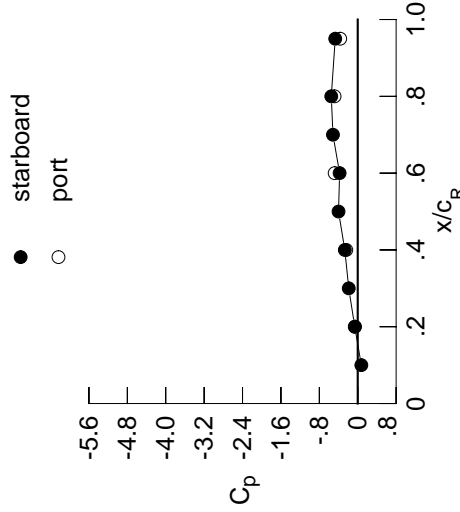

Table E4. Continued.

η	$x/c_R = .2$		$x/c_R = .4$		$x/c_R = .6$		$x/c_R = .8$		$x/c_R = .95$	
	$C_{p,u}$	$C_{p,u}$	$C_{p,u}$	$C_{p,u}$	$C_{p,u}$	$C_{p,u}$	$C_{p,u}$	$C_{p,u}$	$C_{p,u}$	$C_{p,u}$
0.050	-0.0943	-0.0685	0.0794	*****	*****	*****	*****	*****	*****	*****
0.100	-0.0885	-0.0687	0.0683	*****	*****	*****	*****	*****	*****	*****
0.150	-0.0992	-0.0723	0.0579	*****	*****	*****	*****	*****	*****	*****
0.200	-0.1003	-0.0669	0.0420	*****	*****	*****	*****	*****	*****	*****
0.250	*****	-0.0733	0.0276	-0.1826	-0.1826	-0.1826	-0.1826	-0.1826	-0.1826	-0.1826
0.300	-0.1109	-0.0748	0.0129	-0.1672	-0.1672	-0.1672	-0.1672	-0.1672	-0.1672	-0.1672
0.350	*****	-0.0822	0.0019	-0.1575	-0.1575	-0.1575	-0.1575	-0.1575	-0.1575	-0.1575
0.400	-0.1363	-0.0848	-0.0090	-0.1477	-0.1477	-0.1477	-0.1477	-0.1477	-0.1477	-0.1477
0.450	-0.1499	-0.0931	-0.0071	-0.1429	-0.1429	-0.1429	-0.1429	-0.1429	-0.1429	-0.1429
0.500	-0.1619	-0.0955	-0.0332	-0.1416	-0.1416	-0.1416	-0.1416	-0.1416	-0.1416	-0.1416
0.525	*****	-0.1076	-0.0391	-0.1427	-0.1427	-0.1427	-0.1427	-0.1427	-0.1427	-0.1427
0.550	-0.1792	-0.1137	-0.0475	-0.1414	-0.1414	-0.1414	-0.1414	-0.1414	-0.1414	-0.1414
0.575	*****	-0.1216	-0.0472	-0.1458	-0.1458	-0.1458	-0.1458	-0.1458	-0.1458	-0.1458
0.600	-0.1929	-0.1289	-0.0641	-0.1478	-0.1478	-0.1478	-0.1478	-0.1478	-0.1478	-0.1478
0.625	*****	*****	-0.0665	-0.1455	-0.1455	-0.1455	-0.1455	-0.1455	-0.1455	-0.1455
0.650	-0.2066	-0.1424	-0.0782	-0.1500	-0.1500	-0.1500	-0.1500	-0.1500	-0.1500	-0.1500
0.675	*****	-0.1611	-0.0896	-0.1544	-0.1544	-0.1544	-0.1544	-0.1544	-0.1544	-0.1544
0.700	-0.2184	-0.1813	-0.1015	-0.1608	-0.1608	-0.1608	-0.1608	-0.1608	-0.1608	-0.1608
0.725	*****	-0.1995	*****	-0.1666	-0.1666	-0.1666	-0.1666	-0.1666	-0.1666	-0.1666
0.750	-0.2253	-0.2199	*****	-0.1759	-0.1759	-0.1759	-0.1759	-0.1759	-0.1759	-0.1759
0.775	*****	-0.2414	-0.1557	-0.1966	-0.1966	-0.1966	-0.1966	-0.1966	-0.1966	-0.1966
0.800	-0.2273	-0.2631	-0.1853	-0.2114	-0.2114	-0.2114	-0.2114	-0.2114	-0.2114	-0.2114
0.825	*****	-0.2842	-0.2218	-0.2205	-0.2205	-0.2205	-0.2205	-0.2205	-0.2205	-0.2205
0.850	-0.2261	-0.3011	-0.2594	-0.2692	-0.2692	-0.2692	-0.2692	-0.2692	-0.2692	-0.2692
0.875	*****	-0.3203	-0.3032	-0.3152	-0.3152	-0.3152	-0.3152	-0.3152	-0.3152	-0.3152
0.900	-0.2173	-0.3330	-0.3428	-0.3740	-0.3740	-0.3740	-0.3740	-0.3740	-0.3740	-0.3740
0.925	*****	-0.3495	-0.3786	-0.4266	-0.4266	-0.4266	-0.4266	-0.4266	-0.4266	-0.4266
0.950	-0.2072	-0.3480	-0.4095	-0.4701	-0.4701	-0.4701	-0.4701	-0.4701	-0.4701	-0.4701
0.975	*****	-0.3603	-0.4337	-0.5134	-0.5134	-0.5134	-0.5134	-0.5134	-0.5134	-0.5134
1.000	-0.0619	-0.2691	-0.3774	-0.5510	-0.5510	-0.5510	-0.5510	-0.5510	-0.5510	-0.5510
-0.200	$C_{p,l}$	$C_{p,l}$	$C_{p,l}$	$C_{p,l}$	$C_{p,l}$	$C_{p,l}$	$C_{p,l}$	$C_{p,l}$	$C_{p,l}$	$C_{p,l}$
-0.400	0.0792	0.0929	0.1545	*****	*****	*****	*****	*****	*****	*****
-0.600	0.0685	0.0954	0.1189	-0.0334	-0.7221	-0.7221	-0.7221	-0.7221	-0.7221	-0.7221
-0.700	0.0735	0.0887	0.1065	0.0011	-0.7260	-0.7260	-0.7260	-0.7260	-0.7260	-0.7260
-0.800	0.0890	0.0822	0.0989	0.0102	-0.7072	-0.7072	-0.7072	-0.7072	-0.7072	-0.7072
-0.850	0.1227	0.0879	0.0934	0.0234	-0.6478	-0.6478	-0.6478	-0.6478	-0.6478	-0.6478
-0.900	*****	0.1103	0.0947	0.0237	-0.6557	-0.6557	-0.6557	-0.6557	-0.6557	-0.6557
-0.950	*****	0.1434	0.1168	0.0399	-0.6634	-0.6634	-0.6634	-0.6634	-0.6634	-0.6634
-0.975	0.2186	0.1911	0.1712	0.0983	-0.2523	-0.2523	-0.2523	-0.2523	-0.2523	-0.2523
-1.000	*****	0.2206	0.2035	0.1468	-0.0761	-0.0761	-0.0761	-0.0761	-0.0761	-0.0761
	-0.0574	-0.2383	-0.4811	-0.4822	-0.3650	-0.3650	-0.3650	-0.3650	-0.3650	-0.3650

Medium Radius L.E.
 Run No. = 12, Point No. = 246
 $C_N = 0.206$, $C_m = -0.0467$
 $\alpha = 4.8^\circ$, $M_\infty = 0.850$
 $R_{mac} = 36.4 \times 10^6$

Leading Edge Pressures



x/c_R	starb'd C_p	port C_p
0.10	0.0749	*****
0.20	-0.0619	-0.0574
0.30	-0.1870	*****
0.40	-0.2691	-0.2383
0.50	-0.4001	*****
0.60	-0.3774	-0.4811
0.70	-0.5161	*****
0.80	-0.5510	-0.4822
0.90	-0.0084	*****
0.95	-0.4687	-0.3650

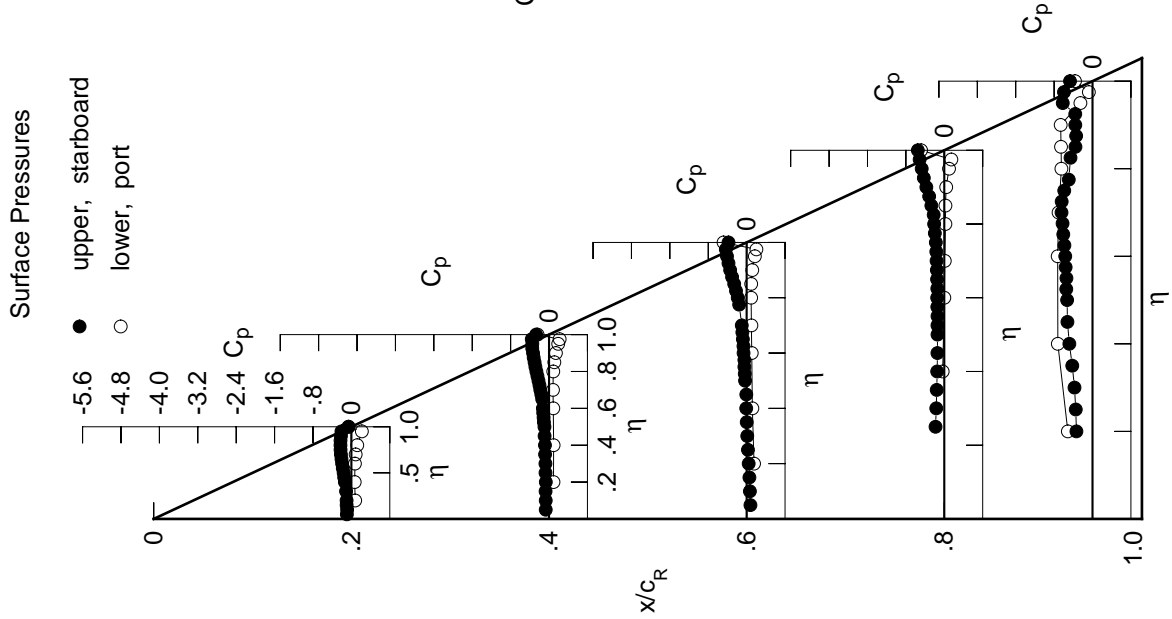
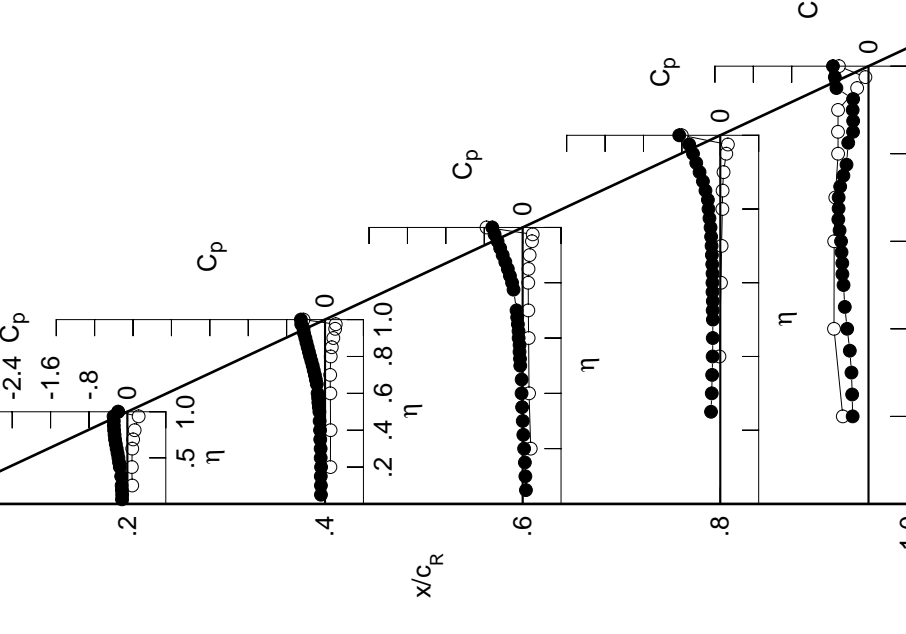
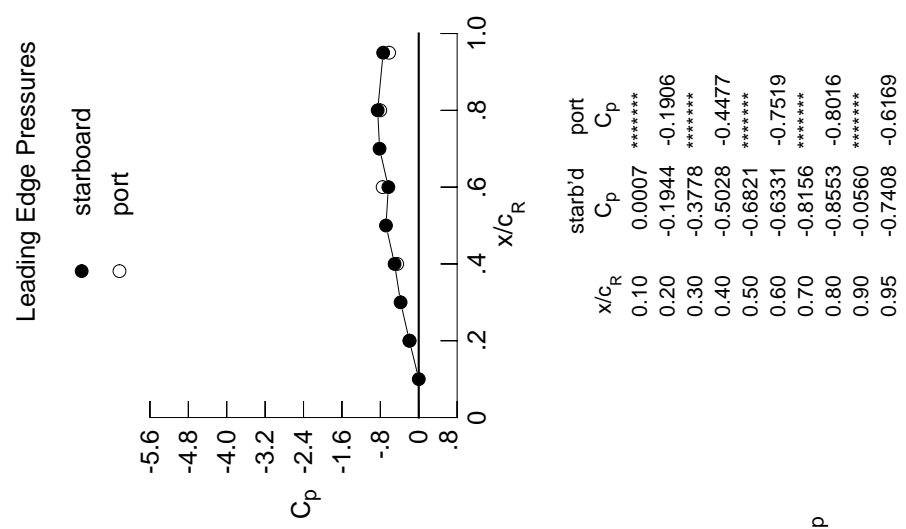

Table E4. Continued.

η	$x/c_R = .2$		$x/c_R = .4$		$x/c_R = .6$		$x/c_R = .8$		$x/c_R = .95$	
	$C_{p,u}$	$C_{p,u}$	$C_{p,u}$	$C_{p,u}$	$C_{p,u}$	$C_{p,u}$	$C_{p,u}$	$C_{p,u}$	$C_{p,u}$	$C_{p,u}$
0.050	-0.1126	-0.0850	0.0686	*****	*****	*****	*****	*****	*****	*****
0.100	-0.1090	-0.0859	0.0572	*****	*****	*****	*****	*****	*****	*****
0.150	-0.1152	-0.0888	0.0460	*****	*****	*****	*****	*****	*****	*****
0.200	-0.1201	-0.0827	0.0308	*****	*****	*****	*****	*****	*****	*****
0.250	*****	-0.0902	0.0148	-0.1932	-0.3404	*****	*****	*****	*****	*****
0.300	-0.1294	-0.0908	0.0021	-0.1779	-0.3549	*****	*****	*****	*****	*****
0.350	*****	-0.1003	-0.0109	-0.1696	-0.3894	*****	*****	*****	*****	*****
0.400	-0.1575	-0.1037	-0.0228	-0.1589	-0.4440	*****	*****	*****	*****	*****
0.450	-0.1732	-0.1129	-0.0204	-0.1566	-0.4945	*****	*****	*****	*****	*****
0.500	-0.1870	-0.1173	-0.0496	-0.1546	-0.5201	*****	*****	*****	*****	*****
0.525	*****	-0.1290	-0.0555	-0.1580	-0.5436	*****	*****	*****	*****	*****
0.550	-0.2049	-0.1389	-0.0648	-0.1563	-0.5453	*****	*****	*****	*****	*****
0.575	*****	-0.1444	-0.0641	-0.1622	-0.5625	*****	*****	*****	*****	*****
0.600	-0.2233	-0.1548	-0.0834	-0.1635	-0.5721	*****	*****	*****	*****	*****
0.625	*****	*****	-0.0856	-0.1616	-0.6025	*****	*****	*****	*****	*****
0.650	-0.2414	-0.1711	-0.0991	-0.1670	-0.6285	*****	*****	*****	*****	*****
0.675	*****	-0.1922	-0.1138	-0.1750	-0.6234	*****	*****	*****	*****	*****
0.700	-0.2578	-0.2122	-0.1271	-0.1817	-0.6222	*****	*****	*****	*****	*****
0.725	*****	-0.2352	*****	-0.1908	-0.5902	*****	*****	*****	*****	*****
0.750	-0.2676	-0.2577	*****	-0.2021	-0.5235	*****	*****	*****	*****	*****
0.775	*****	-0.2840	-0.1897	-0.2256	-0.4587	*****	*****	*****	*****	*****
0.800	-0.2770	-0.3112	-0.2202	-0.2456	*****	*****	*****	*****	*****	*****
0.825	*****	-0.3368	-0.2645	-0.2586	-0.4228	*****	*****	*****	*****	*****
0.850	-0.2823	-0.3615	-0.3089	-0.3090	-0.3221	*****	*****	*****	*****	*****
0.875	*****	-0.3864	-0.3605	-0.3619	-0.3201	*****	*****	*****	*****	*****
0.900	-0.2829	-0.4099	-0.4164	-0.4324	-0.3299	*****	*****	*****	*****	*****
0.925	*****	-0.4368	-0.4681	-0.5011	-0.3212	*****	*****	*****	*****	*****
0.950	-0.2882	-0.4480	-0.5226	-0.5680	-0.6692	*****	*****	*****	*****	*****
0.975	*****	-0.4960	-0.5840	-0.6477	-0.7015	*****	*****	*****	*****	*****
1.000	-0.1944	-0.5028	-0.6331	-0.8553	-0.7408	*****	*****	*****	*****	*****
-0.200	$C_{p,l}$	0.1007	0.1121	0.1688	*****	*****	*****	*****	*****	*****
-0.400		0.0926	0.1149	0.1334	-0.0172	-0.7191	*****	*****	*****	*****
-0.600		0.1006	0.1106	0.1248	0.0142	-0.7156	*****	*****	*****	*****
-0.700		0.1191	0.1069	0.1182	0.0268	-0.6924	*****	*****	*****	*****
-0.800		0.1509	0.1181	0.1167	0.0433	-0.6333	*****	*****	*****	*****
-0.850	*****	0.1405	0.1224	0.1224	0.0480	-0.6361	*****	*****	*****	*****
-0.900	*****	0.1730	0.1453	0.0677	-0.6342	*****	*****	*****	*****	*****
-0.950		0.2342	0.2111	0.1943	0.1246	-0.2371	*****	*****	*****	*****
-0.975	*****	0.2233	0.2097	0.1581	-0.0649	*****	*****	*****	*****	*****
-1.000		-0.1906	-0.4477	-0.7519	-0.8016	-0.6169	*****	*****	*****	*****

Medium Radius L.E.
 Run No. = 12, Point No. = 247
 $C_N = 0.248$, $C_m = -0.0537$
 $\alpha = 5.9^\circ$, $M_\infty = 0.851$
 $R_{mac} = 36.5 \times 10^6$



x/c_R	starb'd C_p	port C_p
0.10	0.0007	*****
0.20	-0.1944	-0.1906
0.30	-0.3778	*****
0.40	-0.5028	-0.4777
0.50	-0.6821	*****
0.60	-0.6331	-0.7519
0.70	-0.8156	*****
0.80	-0.8553	-0.8016
0.90	-0.0560	*****
0.95	-0.7408	-0.6169

Table E4. Continued.

η	$x/c_R = .2$		$x/c_R = .4$		$x/c_R = .6$		$x/c_R = .8$		$x/c_R = .95$	
	$C_{p,u}$	$C_{p,u}$	$C_{p,u}$	$C_{p,u}$	$C_{p,u}$	$C_{p,u}$	$C_{p,u}$	$C_{p,u}$	$C_{p,u}$	$C_{p,u}$
0.050	-0.1296	-0.1010	0.0571	*****	*****	*****	*****	*****	*****	*****
0.100	-0.1268	-0.1024	0.0463	*****	*****	*****	*****	*****	*****	*****
0.150	-0.1342	-0.1053	0.0346	*****	*****	*****	*****	*****	*****	*****
0.200	-0.1384	-0.0994	0.0190	*****	*****	*****	*****	*****	*****	*****
0.250	*****	-0.1071	0.0026	-0.2057	-0.3311	*****	*****	*****	*****	*****
0.300	-0.1492	-0.1093	-0.0105	-0.1910	-0.3399	*****	*****	*****	*****	*****
0.350	*****	-0.1187	-0.0240	-0.1823	-0.3616	*****	*****	*****	*****	*****
0.400	-0.1801	-0.1226	-0.0364	-0.1717	-0.4044	*****	*****	*****	*****	*****
0.450	-0.1968	-0.1340	-0.0356	-0.1692	-0.4535	*****	*****	*****	*****	*****
0.500	-0.2127	-0.1393	-0.0658	-0.1687	-0.5110	*****	*****	*****	*****	*****
0.525	*****	-0.1521	-0.0724	-0.1710	-0.5636	*****	*****	*****	*****	*****
0.550	-0.2328	-0.1621	-0.0823	-0.1702	-0.6044	*****	*****	*****	*****	*****
0.575	*****	-0.1710	-0.0818	-0.1765	-0.6669	*****	*****	*****	*****	*****
0.600	-0.2545	-0.1813	-0.1032	-0.1789	-0.6985	*****	*****	*****	*****	*****
0.625	*****	*****	-0.1061	-0.1786	-0.7180	*****	*****	*****	*****	*****
0.650	-0.2776	-0.2000	-0.1216	-0.1860	-0.7151	*****	*****	*****	*****	*****
0.675	*****	-0.2223	-0.1379	-0.1981	-0.6735	*****	*****	*****	*****	*****
0.700	-0.2964	-0.2457	-0.1556	-0.2121	-0.6014	*****	*****	*****	*****	*****
0.725	*****	-0.2705	*****	-0.2291	-0.5371	*****	*****	*****	*****	*****
0.750	-0.3126	-0.2962	*****	-0.2457	-0.4892	*****	*****	*****	*****	*****
0.775	*****	-0.3265	-0.2282	-0.2710	-0.4343	*****	*****	*****	*****	*****
0.800	-0.3277	-0.3601	-0.2609	-0.2894	*****	*****	*****	*****	*****	*****
0.825	*****	-0.3905	-0.3048	-0.3034	-0.3929	*****	*****	*****	*****	*****
0.850	-0.3408	-0.4232	-0.3549	-0.3412	-0.3292	*****	*****	*****	*****	*****
0.875	*****	-0.4561	-0.4150	-0.3967	-0.3204	*****	*****	*****	*****	*****
0.900	-0.3515	-0.4906	-0.4815	-0.4763	-0.3428	*****	*****	*****	*****	*****
0.925	*****	-0.5326	-0.5466	-0.5590	-0.3415	*****	*****	*****	*****	*****
0.950	-0.3762	-0.5610	-0.6187	-0.6574	-0.7248	*****	*****	*****	*****	*****
0.975	*****	-0.6393	-0.7024	-0.7492	-0.8133	*****	*****	*****	*****	*****
1.000	-0.3504	-0.7635	-0.8139	-1.0944	-0.9651	*****	*****	*****	*****	*****
-0.200	$C_{p,l}$	$C_{p,l}$	$C_{p,l}$	$C_{p,l}$	$C_{p,l}$	$C_{p,l}$	$C_{p,l}$	$C_{p,l}$	$C_{p,l}$	$C_{p,l}$
-0.400	0.1223	0.1307	0.1837	*****	-0.5475	*****	*****	*****	*****	*****
-0.600	0.1162	0.1345	0.1499	-0.0045	-0.7199	*****	*****	*****	*****	*****
-0.700	0.1272	0.1328	0.1425	0.0285	-0.7062	*****	*****	*****	*****	*****
-0.800	0.1465	0.1316	0.1370	0.0426	-0.6821	*****	*****	*****	*****	*****
-0.850	0.1793	0.1454	0.1386	0.0619	-0.6202	*****	*****	*****	*****	*****
-0.900	*****	0.1687	0.1471	0.0692	-0.6206	*****	*****	*****	*****	*****
-0.950	0.2444	0.1986	0.1701	0.0908	-0.6104	*****	*****	*****	*****	*****
-0.975	*****	0.2259	0.2105	0.1428	-0.2273	*****	*****	*****	*****	*****
-1.000	*****	0.2181	0.2082	0.1614	-0.0637	*****	*****	*****	*****	*****
	-0.3513	-0.6713	-0.9634	-1.0054	-0.8395	*****	*****	*****	*****	*****

Medium Radius L.E.
 Run No. = 12, Point No. = 248
 $C_N = 0.292$, $C_m = -0.0621$
 $\alpha = 6.9^\circ$, $M_\infty = 0.850$
 $R_{mac} = 36.5 \times 10^6$

Leading Edge Pressures

● starboard
 ○ port

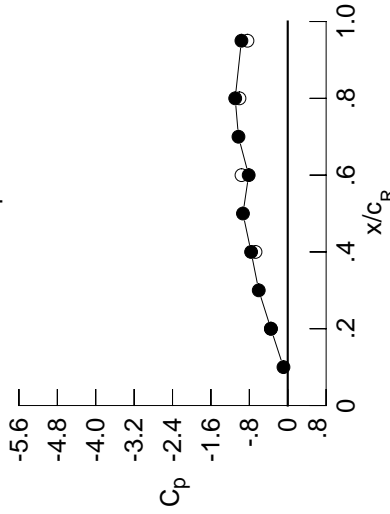

x/c_R	starb'd C_p	port C_p
0.10	-0.0890	*****
0.20	-0.3504	-0.3513
0.30	-0.6043	*****
0.40	-0.7635	-0.6713
0.50	-0.9328	*****
0.60	-0.8139	-0.9634
0.70	-1.0261	*****
0.80	-1.0944	-1.0054
0.90	-0.0977	*****
0.95	-0.9651	-0.8395

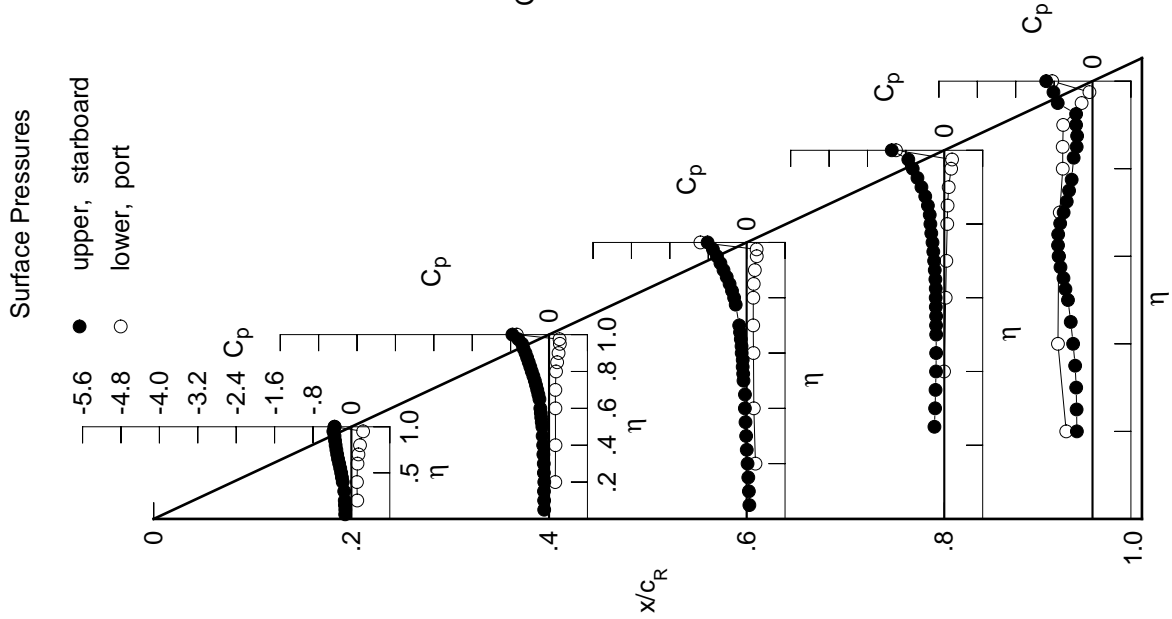

Table E4. Continued.

η	x/c_R .2	x/c_R .4	x/c_R .6	x/c_R .8	x/c_R .95
	$C_{p,u}$	$C_{p,u}$	$C_{p,u}$	$C_{p,u}$	$C_{p,u}$
0.050	-0.1443	-0.1165	0.0444	*****	*****
0.100	-0.1419	-0.1178	0.0331	*****	*****
0.150	-0.1521	-0.1212	0.0218	*****	*****
0.200	-0.1557	-0.1150	0.0068	*****	-0.3256
0.250	*****	-0.1246	-0.0113	-0.2177	-0.3179
0.300	-0.1684	-0.1262	-0.0255	-0.2057	-0.3160
0.350	*****	-0.1372	-0.0390	-0.1960	-0.3281
0.400	-0.2001	-0.1424	-0.0524	-0.1869	-0.3710
0.450	-0.2190	-0.1547	-0.0523	-0.1836	-0.4991
0.500	-0.2370	-0.1621	-0.0829	-0.1813	-0.6485
0.525	*****	-0.1756	-0.0904	-0.1869	-0.7047
0.550	-0.2603	-0.1862	-0.1009	-0.1879	-0.7033
0.575	-0.1968	-0.1030	-0.1990	-0.6991	
0.600	-0.2849	-0.2093	-0.1279	-0.2091	-0.6600
0.625	*****	*****	-0.1401	-0.2157	-0.6060
0.650	-0.3114	-0.2333	-0.1599	-0.2232	-0.5589
0.675	*****	-0.2559	-0.1805	-0.2372	-0.5276
0.700	-0.3358	-0.2786	-0.1978	-0.2609	-0.5131
0.725	*****	-0.3060	*****	-0.2792	-0.5043
0.750	-0.3573	-0.3340	*****	-0.2856	-0.4829
0.775	*****	-0.3681	-0.2651	-0.2901	-0.4902
0.800	-0.3799	-0.4065	-0.2926	-0.3023	*****
0.825	*****	-0.4426	-0.3331	-0.3625	-0.5192
0.850	-0.4013	-0.4841	-0.3875	-0.4154	-0.4840
0.875	*****	-0.5251	-0.4533	-0.4275	-0.5344
0.900	-0.4234	-0.5711	-0.5362	-0.4536	-0.6520
0.925	*****	-0.6276	-0.6304	-0.6405	-0.7736
0.950	-0.4726	-0.6719	-0.7880	-0.8787	-0.6418
0.975	*****	-0.7625	-1.0823	-0.8981	-0.7472
1.000	-0.5358	-0.9833	-0.9254	-1.2188	-1.0477
	$C_{p,l}$	$C_{p,l}$	$C_{p,l}$	$C_{p,l}$	$C_{p,l}$
-0.200	0.1461	0.1506	0.1980	*****	-0.5574
-0.400	0.1405	0.1558	0.1670	0.0110	-0.7104
-0.600	0.1547	0.1563	0.1608	0.0464	-0.6936
-0.700	0.1749	0.1568	0.1567	0.0600	-0.6690
-0.800	0.2066	0.1727	0.1624	0.0822	-0.6027
-0.850	*****	0.1958	0.1712	0.0895	-0.6023
-0.900	*****	0.2215	0.1933	0.1138	-0.5840
-0.950	0.2506	0.2359	0.2224	0.1583	-0.2102
-0.975	*****	0.2077	0.2021	0.1628	-0.0500
-1.000	-0.5417	-0.8720	-1.1191	-1.1205	-0.8607

Medium Radius L.E.
 Run No. = 12, Point No. = 249
 $C_N = 0.341$, $C_m = -0.0717$
 $\alpha = 7.9^\circ$, $M_\infty = 0.849$
 $R_{mac} = 36.5 \times 10^6$

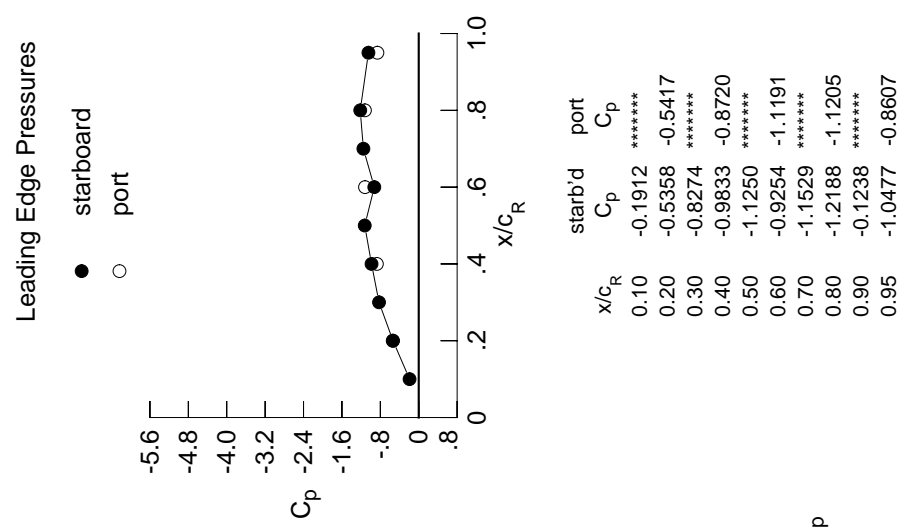
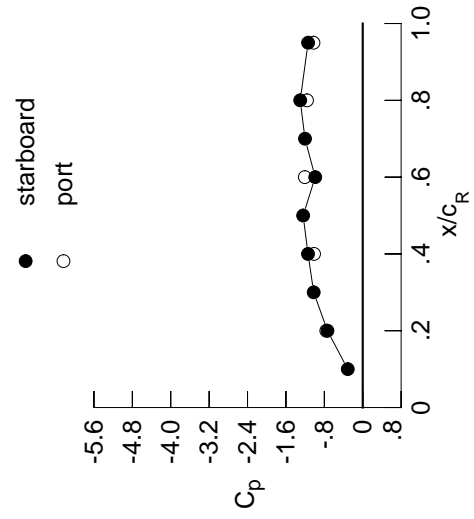

Table E4. Continued.

η	$x/c_R = .2$		$x/c_R = .4$		$x/c_R = .6$		$x/c_R = .8$		$x/c_R = .95$	
	$C_{p,u}$	$C_{p,u}$	$C_{p,u}$	$C_{p,u}$	$C_{p,u}$	$C_{p,u}$	$C_{p,u}$	$C_{p,u}$	$C_{p,u}$	$C_{p,u}$
0.050	-0.1602	-0.1346	0.0297	*****	*****	*****	*****	*****	*****	
0.100	-0.1592	-0.1368	0.0186	*****	*****	*****	*****	*****	*****	
0.150	-0.1708	-0.1406	0.0047	*****	*****	*****	*****	*****	*****	
0.200	-0.1760	-0.1357	-0.0102	*****	*****	*****	*****	*****	*****	
0.250	*****	-0.1452	-0.0284	-0.2414	-0.2836	*****	*****	*****	*****	
0.300	-0.1893	-0.1484	-0.0413	-0.2278	-0.2540	*****	*****	*****	*****	
0.350	*****	-0.1601	-0.0563	-0.2162	-0.3112	*****	*****	*****	*****	
0.400	-0.2241	-0.1640	-0.0673	-0.2055	-0.4365	*****	*****	*****	*****	
0.450	-0.2433	-0.1791	-0.0684	-0.2061	-0.5702	*****	*****	*****	*****	
0.500	-0.2639	-0.1881	-0.1084	-0.2142	-0.5427	*****	*****	*****	*****	
0.525	*****	-0.2067	-0.1217	-0.2262	-0.5273	*****	*****	*****	*****	
0.550	-0.2897	-0.2199	-0.1404	-0.2351	-0.4999	*****	*****	*****	*****	
0.575	*****	-0.2338	-0.1495	-0.2507	-0.4963	*****	*****	*****	*****	
0.600	-0.3171	-0.2503	-0.1802	-0.2533	-0.4819	*****	*****	*****	*****	
0.625	*****	*****	-0.1915	-0.2488	-0.4780	*****	*****	*****	*****	
0.650	-0.3492	-0.2742	-0.2041	-0.2580	-0.4659	*****	*****	*****	*****	
0.675	*****	-0.2953	-0.2195	-0.2817	-0.4517	*****	*****	*****	*****	
0.700	-0.3786	-0.3182	-0.2261	-0.3234	-0.4580	*****	*****	*****	*****	
0.725	*****	-0.3433	*****	-0.3466	-0.4655	*****	*****	*****	*****	
0.750	-0.4081	-0.3738	*****	-0.3313	-0.4558	*****	*****	*****	*****	
0.775	*****	-0.4091	-0.3281	-0.3337	-0.4598	*****	*****	*****	*****	
0.800	-0.4383	-0.4522	-0.3665	-0.3491	*****	*****	*****	*****	*****	
0.825	*****	-0.4929	-0.3942	-0.4129	-0.5012	*****	*****	*****	*****	
0.850	-0.4700	-0.5400	-0.3948	-0.5416	-0.4541	*****	*****	*****	*****	
0.875	*****	-0.5922	-0.4268	-0.4845	-0.4481	*****	*****	*****	*****	
0.900	-0.5074	-0.6429	-0.7362	-0.4422	-0.7603	*****	*****	*****	*****	
0.925	*****	-0.7098	-0.8841	-0.7252	-0.8335	*****	*****	*****	*****	
0.950	-0.5862	-0.8342	-0.8498	-1.1491	-0.6639	*****	*****	*****	*****	
0.975	*****	-1.1506	-1.2332	-0.9098	-0.8294	*****	*****	*****	*****	
1.000	-0.7351	-1.1398	-0.9899	-1.3023	-1.1386	*****	*****	*****	*****	
-0.200	$C_{p,l}$	0.1709	$C_{p,l}$	0.2167	*****	*****	*****	*****	*****	
-0.400	$C_{p,l}$	0.1673	$C_{p,l}$	0.1794	0.1852	0.0270	-0.7027	*****	*****	
-0.600	$C_{p,l}$	0.1834	$C_{p,l}$	0.1810	0.1816	0.0632	-0.6829	*****	*****	
-0.700	$C_{p,l}$	0.2032	$C_{p,l}$	0.1833	0.1794	0.0771	-0.6524	*****	*****	
-0.800	$C_{p,l}$	0.2335	$C_{p,l}$	0.2012	0.1845	0.1012	-0.5882	*****	*****	
-0.850	$C_{p,l}$	*****	$C_{p,l}$	0.2224	0.1950	0.1100	-0.5866	*****	*****	
-0.900	$C_{p,l}$	*****	$C_{p,l}$	0.2440	0.2148	0.1338	-0.5644	*****	*****	
-0.950	$C_{p,l}$	0.2524	$C_{p,l}$	0.2449	0.2318	0.1715	-0.2086	*****	*****	
-0.975	$C_{p,l}$	*****	$C_{p,l}$	0.1954	0.1962	0.1617	-0.0662	*****	*****	
-1.000	$C_{p,l}$	-0.7595	$C_{p,l}$	-1.0147	-1.2067	-1.1605	-1.0262	*****	*****	

Medium Radius L.E.
 Run No. = 12, Point No. = 250
 $C_N = 0.396$, $C_m = -0.0828$
 $\alpha = 9.0^\circ$, $M_\infty = 0.850$
 $R_{mac} = 36.4 \times 10^6$

Leading Edge Pressures



x/c_R	starb'd C_p	port C_p
0.10	-0.3124	*****
0.20	-0.7351	-0.7595
0.30	-1.0216	*****
0.40	-1.1398	-1.0147
0.50	-1.2416	*****
0.60	-0.9899	-1.2067
0.70	-1.2027	*****
0.80	-1.3023	-1.1605
0.90	-0.1309	*****
0.95	-1.1386	-1.0262

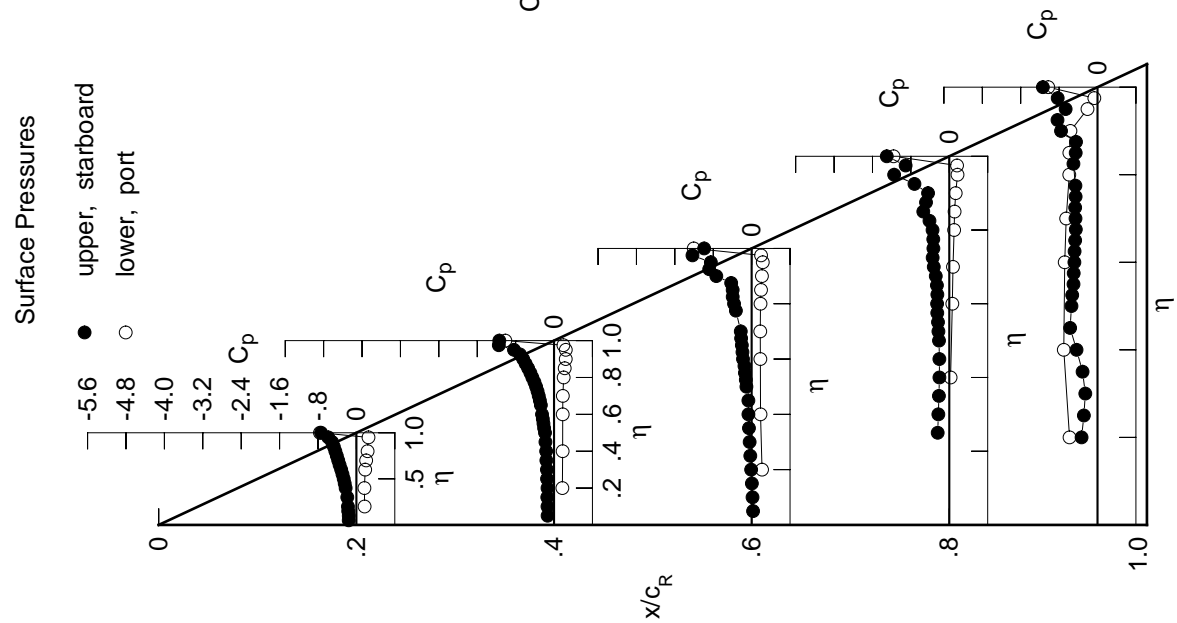
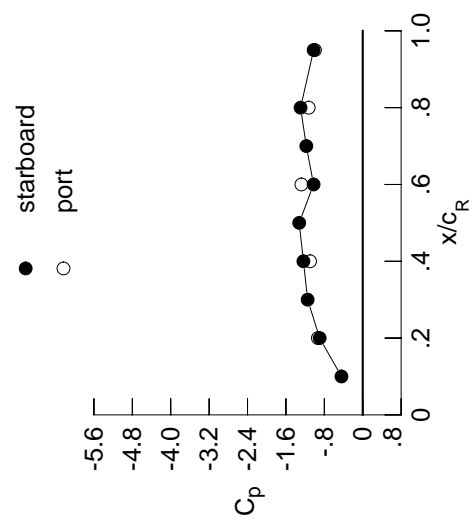

Table E4. Continued.

η	x/c_R .2	x/c_R .4	x/c_R .6	x/c_R .8	x/c_R .95
	$C_{p,u}$	$C_{p,u}$	$C_{p,u}$	$C_{p,u}$	$C_{p,u}$
0.050	-0.1743	-0.1558	0.0112	*****	*****
0.100	-0.1766	-0.1570	-0.0028	*****	*****
0.150	-0.1887	-0.1622	-0.0158	*****	*****
0.200	-0.1958	-0.1576	-0.0305	*****	-0.2993
0.250	*****	-0.1683	-0.0492	-0.2683	-0.2440
0.300	-0.2102	-0.1706	-0.0612	-0.2508	-0.2729
0.350	*****	-0.1825	-0.0756	-0.2398	-0.3627
0.400	-0.2459	-0.1876	-0.0940	-0.2318	-0.4566
0.450	-0.2669	-0.2076	-0.1079	-0.2456	-0.4742
0.500	-0.2894	-0.2285	-0.1574	-0.2547	-0.4600
0.525	*****	-0.2501	-0.1650	-0.2594	-0.4596
0.550	-0.3187	-0.2654	-0.1784	-0.2661	-0.4379
0.575	*****	-0.2774	-0.1915	-0.2853	-0.4323
0.600	-0.3495	-0.2901	-0.2287	-0.2969	-0.4295
0.625	*****	*****	-0.2335	-0.2875	-0.4442
0.650	-0.3848	-0.3130	-0.2329	-0.2728	-0.4515
0.675	*****	-0.3332	-0.2445	-0.2685	-0.4468
0.700	-0.4199	-0.3573	-0.2588	-0.2590	-0.4827
0.725	*****	-0.3808	*****	-0.2554	-0.5924
0.750	-0.4548	-0.4068	*****	-0.3114	-0.7053
0.775	*****	-0.4413	-0.4178	-0.5559	-0.7222
0.800	-0.4934	-0.4774	-0.4179	-0.8081	*****
0.825	*****	-0.5040	-0.4126	-0.9063	-0.6032
0.850	-0.5418	-0.5728	-0.3777	-0.7932	-0.5533
0.875	*****	-0.7512	-0.5726	-0.6391	-0.5676
0.900	-0.5905	-0.8178	-1.1530	-0.5995	-0.6229
0.925	*****	-1.0015	-1.1689	-0.7224	-0.6753
0.950	-0.6929	-1.2036	-1.1575	-0.9913	-0.6394
0.975	*****	-1.2313	-1.1058	-0.7822	-0.7615
1.000	-0.8978	-1.2358	-1.0243	-1.2953	-1.0230
	$C_{p,l}$	$C_{p,l}$	$C_{p,l}$	$C_{p,l}$	$C_{p,l}$
-0.200	0.1984	0.1990	0.2355	*****	-0.6046
-0.400	0.1958	0.2041	0.2049	0.0431	-0.6941
-0.600	0.2133	0.2077	0.2019	0.0801	-0.6714
-0.700	0.2332	0.2105	0.2008	0.0950	-0.6450
-0.800	0.2601	0.2289	0.2075	0.1189	-0.5756
-0.850	*****	0.2481	0.2177	0.1292	-0.5726
-0.900	*****	0.2656	0.2352	0.1524	-0.5445
-0.950	0.2542	0.2523	0.2401	0.1823	-0.1984
-0.975	*****	0.1839	0.1878	0.1603	-0.0602
-1.000	-0.9342	-1.0967	-1.2780	-1.1264	-0.9952

Medium Radius L.E.
 Run No. = 12, Point No. = 251
 $C_N = 0.450$, $C_m = -0.0916$
 $\alpha = 10.0^\circ$, $M_\infty = 0.851$
 $R_{mac} = 36.4 \times 10^6$

Leading Edge Pressures



x/c_R	starb'd C_p	port C_p
0.10	-0.4430	*****
0.20	-0.8978	-0.9342
0.30	-1.1477	*****
0.40	-1.2358	-1.0967
0.50	-1.3232	*****
0.60	-1.0243	-1.2780
0.70	-1.1754	*****
0.80	-1.2953	-1.1264
0.90	-0.1295	*****
0.95	-1.0230	-0.9952

Surface Pressures

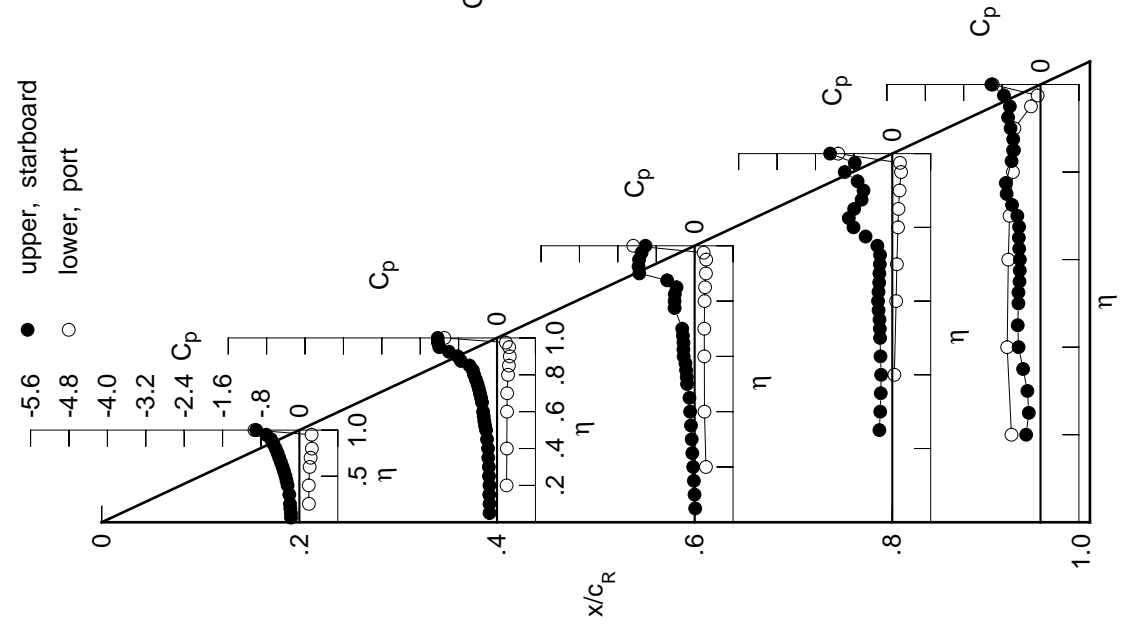
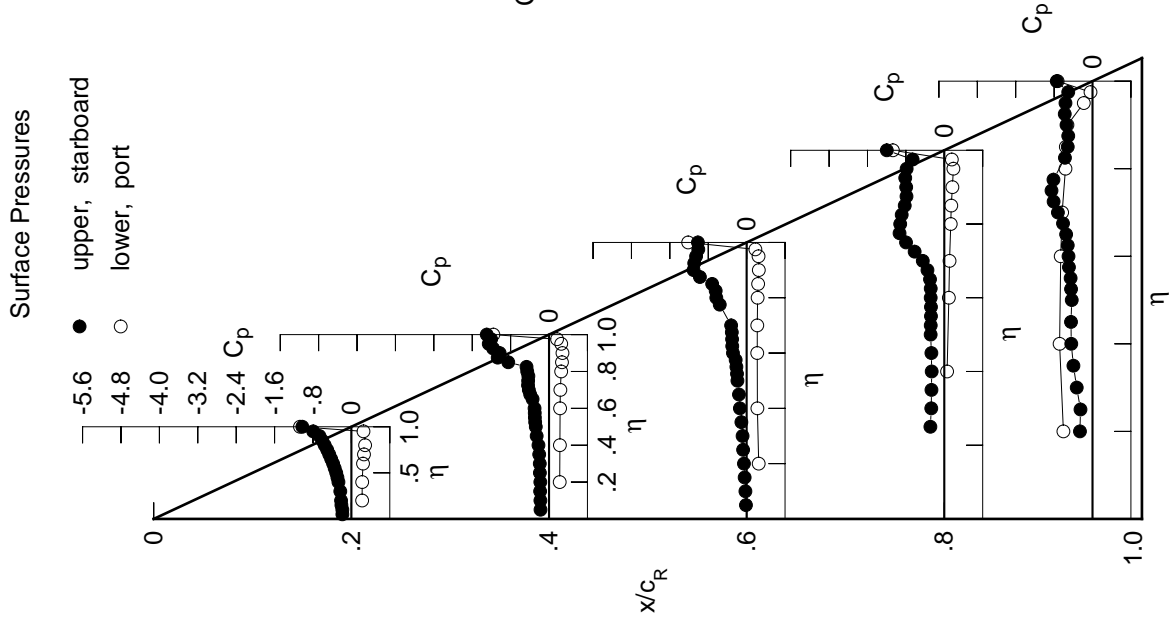

Table E4. Continued.

η	$x/c_R = .2$		$x/c_R = .4$		$x/c_R = .6$		$x/c_R = .8$		$x/c_R = .95$	
	$C_{p,u}$	$C_{p,u}$	$C_{p,u}$	$C_{p,u}$	$C_{p,u}$	$C_{p,u}$	$C_{p,u}$	$C_{p,u}$	$C_{p,u}$	$C_{p,u}$
0.050	-0.1883	-0.1779	-0.0143	*****	*****	*****	*****	*****	*****	*****
0.100	-0.1891	-0.1799	-0.0257	*****	*****	*****	*****	*****	*****	*****
0.150	-0.2076	-0.1853	-0.0418	*****	*****	*****	*****	*****	*****	*****
0.200	-0.2152	-0.1815	-0.0564	*****	*****	*****	*****	*****	*****	-0.2619
0.250	*****	-0.1905	-0.0732	-0.2899	-0.2504	*****	*****	*****	*****	-0.2504
0.300	-0.2315	-0.1929	-0.0846	-0.2712	-0.3289	*****	*****	*****	*****	-0.3289
0.350	*****	-0.2051	-0.1099	-0.2673	-0.3977	*****	*****	*****	*****	-0.3977
0.400	-0.2695	-0.2198	-0.1408	-0.2625	-0.4428	*****	*****	*****	*****	-0.4428
0.450	-0.2908	-0.2579	-0.1600	-0.2691	-0.4482	*****	*****	*****	*****	-0.4482
0.500	-0.3159	-0.2761	-0.1917	-0.2842	-0.4325	*****	*****	*****	*****	-0.4325
0.525	*****	-0.2884	-0.2004	-0.2821	-0.4469	*****	*****	*****	*****	-0.4469
0.550	-0.3479	-0.2953	-0.2136	-0.2773	-0.4562	*****	*****	*****	*****	-0.4562
0.575	*****	-0.2975	-0.2291	-0.2776	-0.4913	*****	*****	*****	*****	-0.4913
0.600	-0.3812	-0.3017	-0.2846	-0.2829	-0.5001	*****	*****	*****	*****	-0.5001
0.625	*****	*****	-0.2997	-0.2826	-0.5162	*****	*****	*****	*****	-0.5162
0.650	-0.4211	-0.3428	-0.3036	-0.2978	-0.5497	*****	*****	*****	*****	-0.5497
0.675	*****	-0.3917	-0.3089	-0.3500	-0.6147	*****	*****	*****	*****	-0.6147
0.700	-0.4615	-0.4209	-0.3235	-0.4483	-0.7207	*****	*****	*****	*****	-0.7207
0.725	*****	-0.4377	*****	-0.6178	-0.8100	*****	*****	*****	*****	-0.8100
0.750	-0.5042	-0.4356	*****	-0.7965	-0.8546	*****	*****	*****	*****	-0.8546
0.775	*****	-0.4303	-0.5597	-0.9317	-0.8136	*****	*****	*****	*****	-0.8136
0.800	-0.5563	-0.4544	-0.6320	-0.9185	*****	*****	*****	*****	*****	-0.9185
0.825	*****	-0.4688	-0.6445	-0.8876	-0.5748	*****	*****	*****	*****	-0.5748
0.850	-0.6062	-0.8500	-0.7186	-0.8242	-0.5163	*****	*****	*****	*****	-0.5163
0.875	*****	-1.0694	-0.9736	-0.7870	-0.5053	*****	*****	*****	*****	-0.5053
0.900	-0.6653	-1.0286	-1.1052	-0.7932	-0.5414	*****	*****	*****	*****	-0.5414
0.925	*****	-1.1655	-1.0923	-0.8139	-0.5783	*****	*****	*****	*****	-0.5783
0.950	-0.7964	-1.2558	-1.0524	-0.7840	-0.5634	*****	*****	*****	*****	-0.5634
0.975	*****	-1.2066	-1.0070	-0.6594	-0.5053	*****	*****	*****	*****	-0.5053
1.000	-1.0219	-1.2979	-1.0149	-1.1973	-0.7446	*****	*****	*****	*****	-0.7446
-0.200	$C_{p,l}$	$C_{p,l}$	$C_{p,l}$	$C_{p,l}$	$C_{p,l}$	$C_{p,l}$	$C_{p,l}$	$C_{p,l}$	$C_{p,l}$	$C_{p,l}$
-0.400	0.2241	0.2225	0.2514	*****	-0.6063	*****	*****	*****	*****	-0.6063
-0.600	0.2245	0.2263	0.2239	0.0685	-0.6856	*****	*****	*****	*****	-0.6856
-0.700	0.2428	0.2305	0.2209	0.0952	-0.6621	*****	*****	*****	*****	-0.6621
-0.800	0.2620	0.2359	0.2215	0.1096	-0.6325	*****	*****	*****	*****	-0.6325
-0.850	0.2853	0.2532	0.2284	0.1346	-0.5635	*****	*****	*****	*****	-0.5635
-0.900	*****	0.2699	0.2394	0.1455	-0.5563	*****	*****	*****	*****	-0.5563
-0.950	*****	0.2803	0.2532	0.1687	-0.5224	*****	*****	*****	*****	-0.5224
-0.975	0.2522	0.2539	0.2480	0.1898	-0.1818	*****	*****	*****	*****	-0.1818
-1.000	0.2552	0.1674	0.1816	0.1566	-0.0413	*****	*****	*****	*****	-0.0413
-1.000	-1.0709	-1.1599	-1.2182	-1.0706	-0.7270	*****	*****	*****	*****	-0.7270



Medium Radius L.E.
 Run No. = 12, Point No. = 252
 $C_N = 0.513$, $C_m = -0.1038$
 $\alpha = 11.1^\circ$, $M_\infty = 0.849$
 $R_{mac} = 36.1 \times 10^6$

Leading Edge Pressures

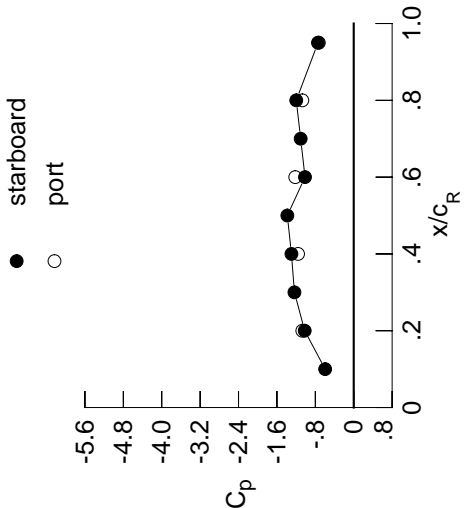

x/c_R	starb'd C_p	port C_p
0.10	-0.5949	*****
0.20	-1.0219	-1.0709
0.30	-1.2350	*****
0.40	-1.2979	-1.1599
0.50	-1.3829	*****
0.60	-1.0149	-1.2182
0.70	-1.1052	*****
0.80	-1.1973	-1.0706
0.90	-0.1316	*****
0.95	-0.7446	-0.7270

Table E4. Continued.

η	$x/c_R = 0.2$		$x/c_R = 0.4$		$x/c_R = 0.6$		$x/c_R = 0.8$		$x/c_R = 0.95$	
	$C_{p,u}$	$C_{p,l}$	$C_{p,u}$	$C_{p,l}$	$C_{p,u}$	$C_{p,l}$	$C_{p,u}$	$C_{p,l}$	$C_{p,u}$	$C_{p,l}$
0.050	-0.2072	-0.2078	-0.0395	*****	*****	*****	*****	*****	*****	*****
0.100	-0.2025	-0.2079	-0.0519	*****	*****	*****	*****	*****	*****	*****
0.150	-0.2299	-0.2129	-0.0683	*****	*****	*****	*****	*****	*****	*****
0.200	-0.2391	-0.2106	-0.0788	*****	*****	*****	*****	*****	*****	-0.2124
0.250	*****	-0.2168	-0.0952	-0.3201	-0.3201	-0.3201	-0.3201	-0.3201	-0.3201	-0.2619
0.300	-0.2599	-0.2167	-0.1151	-0.3020	-0.3020	-0.3020	-0.3020	-0.3020	-0.3020	-0.3606
0.350	*****	-0.2406	-0.1470	-0.2999	-0.2999	-0.2999	-0.2999	-0.2999	-0.2999	-0.4118
0.400	-0.2994	-0.2731	-0.1731	-0.2936	-0.2936	-0.2936	-0.2936	-0.2936	-0.2936	-0.4441
0.450	-0.3244	-0.3049	-0.1960	-0.2802	-0.2802	-0.2802	-0.2802	-0.2802	-0.2802	-0.4883
0.500	-0.3502	-0.3049	-0.2264	-0.2741	-0.2741	-0.2741	-0.2741	-0.2741	-0.2741	-0.5630
0.525	*****	-0.3071	-0.2325	-0.2759	-0.2759	-0.2759	-0.2759	-0.2759	-0.2759	-0.5974
0.550	-0.3819	-0.3083	-0.2426	-0.2801	-0.2801	-0.2801	-0.2801	-0.2801	-0.2801	-0.5920
0.575	*****	-0.3116	-0.2533	-0.3012	-0.3012	-0.3012	-0.3012	-0.3012	-0.3012	-0.6138
0.600	-0.4152	-0.3249	-0.3101	-0.3311	-0.3311	-0.3311	-0.3311	-0.3311	-0.3311	-0.6277
0.625	*****	*****	-0.3534	-0.3755	-0.3755	-0.3755	-0.3755	-0.3755	-0.3755	-0.6898
0.650	-0.4596	-0.3900	-0.4231	-0.4742	-0.4742	-0.4742	-0.4742	-0.4742	-0.4742	-0.7966
0.675	*****	-0.4523	-0.4760	-0.6397	-0.6397	-0.6397	-0.6397	-0.6397	-0.6397	-0.9096
0.700	-0.5057	-0.4751	-0.5091	-0.8328	-0.8328	-0.8328	-0.8328	-0.8328	-0.8328	-0.9979
0.725	*****	-0.4837	*****	-0.9862	-1.0103	-1.0103	-1.0103	-1.0103	-1.0103	-1.0103
0.750	-0.5598	-0.4827	*****	-1.0357	-0.9186	-0.9186	-0.9186	-0.9186	-0.9186	-0.9186
0.775	*****	-0.4482	-0.7819	-1.0289	-0.7426	-0.7426	-0.7426	-0.7426	-0.7426	-0.7426
0.800	-0.6065	-0.4268	-0.8671	-0.9506	*****	*****	*****	*****	*****	*****
0.825	*****	-0.4416	-0.9343	-0.9096	-0.5541	-0.5541	-0.5541	-0.5541	-0.5541	-0.5541
0.850	-0.6642	-1.2474	-0.9919	-0.8560	-0.5019	-0.5019	-0.5019	-0.5019	-0.5019	-0.5019
0.875	*****	-1.3970	-1.0481	-0.8203	-0.4887	-0.4887	-0.4887	-0.4887	-0.4887	-0.4887
0.900	-0.8178	-1.3398	-1.0401	-0.8016	-0.5102	-0.5102	-0.5102	-0.5102	-0.5102	-0.5102
0.925	*****	-1.3355	-0.9864	-0.7869	-0.5397	-0.5397	-0.5397	-0.5397	-0.5397	-0.5397
0.950	-1.1560	-1.2888	-0.9367	-0.7446	-0.4408	-0.4408	-0.4408	-0.4408	-0.4408	-0.4408
0.975	*****	-1.2318	-0.9020	-0.6474	-0.3660	-0.3660	-0.3660	-0.3660	-0.3660	-0.3660
1.000	-1.1183	-1.3163	-0.9552	-1.0960	-0.5660	-0.5660	-0.5660	-0.5660	-0.5660	-0.5660

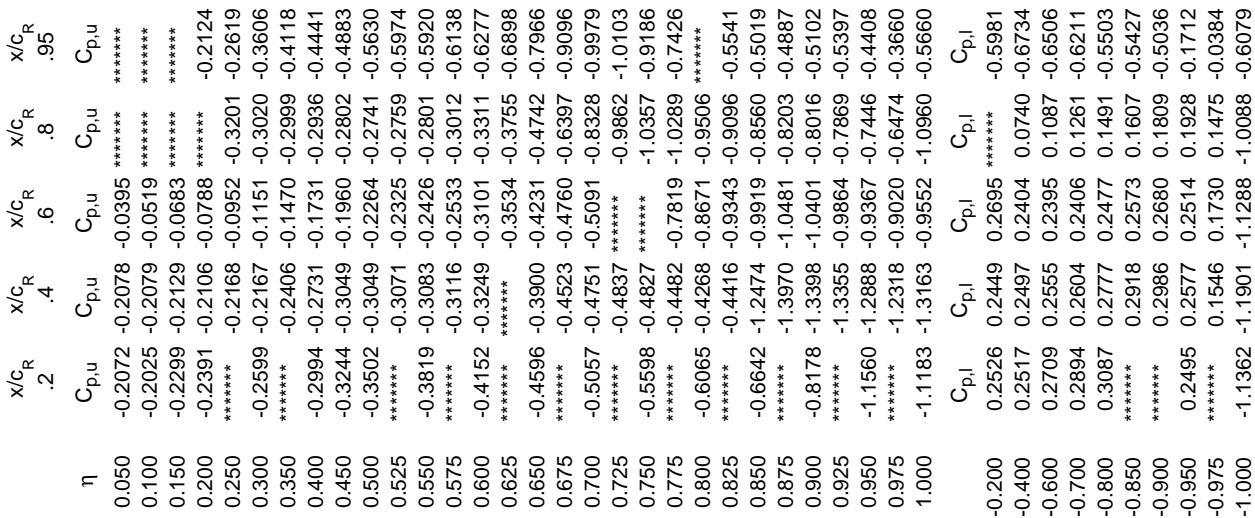

Medium Radius L.E.

Run No. = 12, Point No. = 253

$C_N = 0.575$, $C_m = -0.1160$

$\alpha = 12.1^\circ$, $M_\infty = 0.851$

$R_{mac} = 36.1 \times 10^6$

Leading Edge Pressures

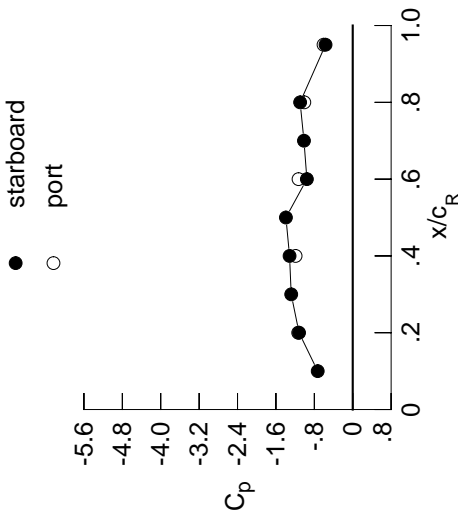

x/c_R	starb'd C_p	port C_p
0.10	-0.7294	*****
0.20	-1.1183	-1.1362
0.30	-1.2818	*****
0.40	-1.3163	-1.1901
0.50	-1.3918	*****
0.60	-0.9552	-1.1288
0.70	-1.0160	*****
0.80	-1.0960	-1.0088
0.90	-0.1193	*****
0.95	-0.5660	-0.6079

Table E4. Continued.

η	$x/c_R = .2$		$x/c_R = .4$		$x/c_R = .6$		$x/c_R = .8$		$x/c_R = .95$	
	$C_{p,u}$	$C_{p,u}$	$C_{p,u}$	$C_{p,u}$	$C_{p,u}$	$C_{p,u}$	$C_{p,u}$	$C_{p,u}$	$C_{p,u}$	$C_{p,u}$
0.050	-0.2278	-0.2494	-0.0636	*****	*****	*****	*****	*****	*****	*****
0.100	-0.2159	-0.2507	-0.0740	*****	*****	*****	*****	*****	*****	*****
0.150	-0.2480	-0.2542	-0.0908	*****	*****	*****	*****	*****	*****	*****
0.200	-0.2629	-0.2542	-0.1003	*****	*****	*****	*****	*****	*****	*****
0.250	*****	-0.2578	-0.1182	-0.3489	-0.2923	*****	*****	*****	*****	*****
0.300	-0.2890	-0.2705	-0.1449	-0.3339	-0.3955	*****	*****	*****	*****	*****
0.350	*****	-0.3051	-0.1703	-0.3210	-0.4650	*****	*****	*****	*****	*****
0.400	-0.3349	-0.3381	-0.1896	-0.3139	-0.5217	*****	*****	*****	*****	*****
0.450	-0.3548	-0.3635	-0.2129	-0.3199	-0.5285	*****	*****	*****	*****	*****
0.500	-0.3764	-0.3627	-0.2862	-0.3140	-0.5388	*****	*****	*****	*****	*****
0.525	*****	-0.3690	-0.3027	-0.3148	-0.5665	*****	*****	*****	*****	*****
0.550	-0.4082	-0.3744	-0.3091	-0.3206	-0.5799	*****	*****	*****	*****	*****
0.575	*****	-0.3851	-0.3146	-0.3485	-0.6327	*****	*****	*****	*****	*****
0.600	-0.4429	-0.4056	-0.3618	-0.4057	-0.6940	*****	*****	*****	*****	*****
0.625	*****	*****	-0.3920	-0.5038	-0.8104	*****	*****	*****	*****	*****
0.650	-0.4878	-0.4993	-0.4979	-0.6828	-0.9534	*****	*****	*****	*****	*****
0.675	*****	-0.5914	-0.6615	-0.9038	-1.0829	*****	*****	*****	*****	*****
0.700	-0.5471	-0.6418	-0.8233	-1.0874	-1.1737	*****	*****	*****	*****	*****
0.725	*****	-0.6176	*****	-1.1936	-1.1766	*****	*****	*****	*****	*****
0.750	-0.5826	-0.5936	*****	-1.1796	-0.8854	*****	*****	*****	*****	*****
0.775	*****	-0.5853	-1.0178	-1.1218	-0.7285	*****	*****	*****	*****	*****
0.800	-0.6099	-0.5786	-0.9926	-1.0167	*****	*****	*****	*****	*****	*****
0.825	*****	-0.8298	-0.9897	-0.9551	-0.5490	*****	*****	*****	*****	*****
0.850	-0.8732	-1.3074	-1.0037	-0.8758	-0.4928	*****	*****	*****	*****	*****
0.875	*****	-1.3769	-1.0254	-0.8199	-0.4689	*****	*****	*****	*****	*****
0.900	-1.1801	-1.3011	-0.9964	-0.7868	-0.4633	*****	*****	*****	*****	*****
0.925	*****	-1.2887	-0.9381	-0.7629	-0.4667	*****	*****	*****	*****	*****
0.950	-1.2706	-1.3392	-0.8941	-0.7257	-0.3897	*****	*****	*****	*****	*****
0.975	*****	-1.3006	-0.8601	-0.6439	-0.3272	*****	*****	*****	*****	*****
1.000	-1.2024	-1.3535	-0.9174	-1.0194	-0.4879	*****	*****	*****	*****	*****
-0.200	$C_{p,l}$	$C_{p,l}$	$C_{p,l}$	$C_{p,l}$	$C_{p,l}$	$C_{p,l}$	$C_{p,l}$	$C_{p,l}$	$C_{p,l}$	$C_{p,l}$
-0.400	0.2804	0.2681	0.2872	*****	*****	*****	*****	*****	*****	*****
-0.600	0.2815	0.2744	0.2596	0.0885	-0.6642	*****	*****	*****	*****	*****
-0.700	0.3007	0.2783	0.2587	0.1231	-0.6434	*****	*****	*****	*****	*****
-0.800	0.3169	0.2855	0.2598	0.1399	-0.6119	*****	*****	*****	*****	*****
-0.850	0.3334	0.3015	0.2666	0.1640	-0.5396	*****	*****	*****	*****	*****
-0.900	*****	0.3124	0.2747	0.1750	-0.5293	*****	*****	*****	*****	*****
-0.950	*****	0.3127	0.2815	0.1937	-0.4864	*****	*****	*****	*****	*****
-0.975	0.2477	0.2591	0.2532	0.1973	-0.1619	*****	*****	*****	*****	*****
-1.000	*****	0.1407	0.1616	0.1394	-0.0351	*****	*****	*****	*****	*****
-1.000	-1.1900	-1.2111	-1.0442	-0.9625	-0.5257	*****	*****	*****	*****	*****

Medium Radius L.E.
 Run No. = 12, Point No. = 254
 $C_N = 0.633$, $C_m = -0.1239$
 $\alpha = 13.1^\circ$, $M_\infty = 0.848$
 $R_{mac} = 36.0 \times 10^6$

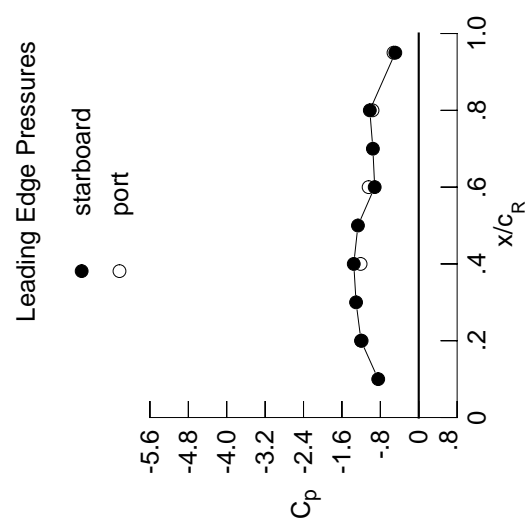

x/c_R	starb'd C_p	port C_p
0.10	-0.8441	*****
0.20	-1.2024	-1.1900
0.30	-1.3053	*****
0.40	-1.3535	-1.2111
0.50	-1.2664	*****
0.60	-0.9174	-1.0442
0.70	-0.9554	*****
0.80	-1.0194	-0.9625
0.90	-0.1019	*****
0.95	-0.4879	-0.5257

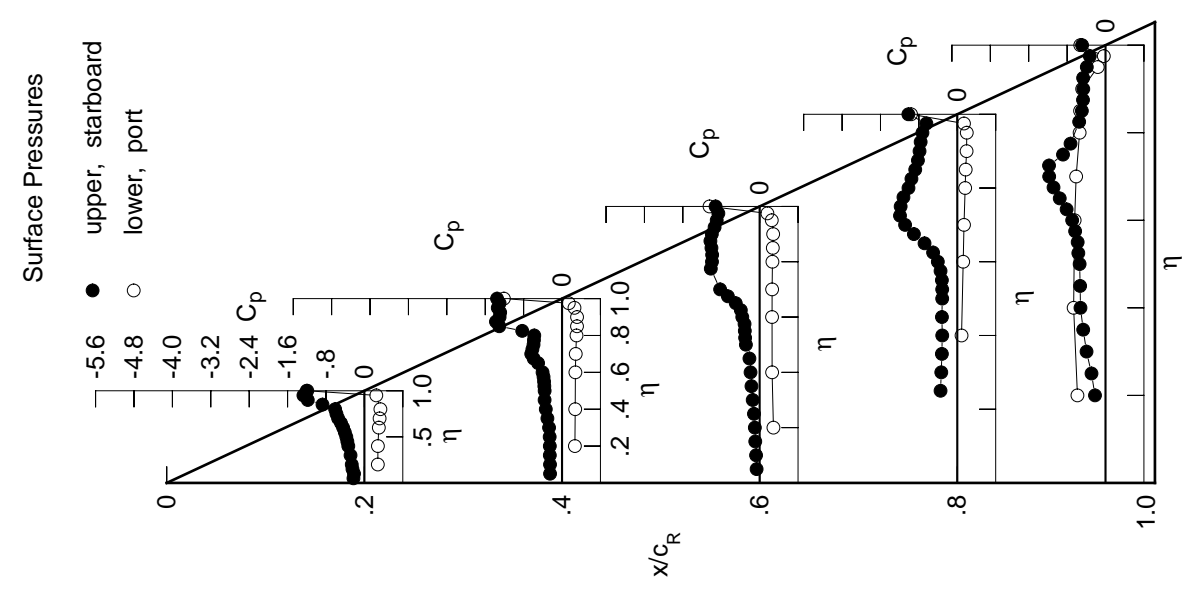
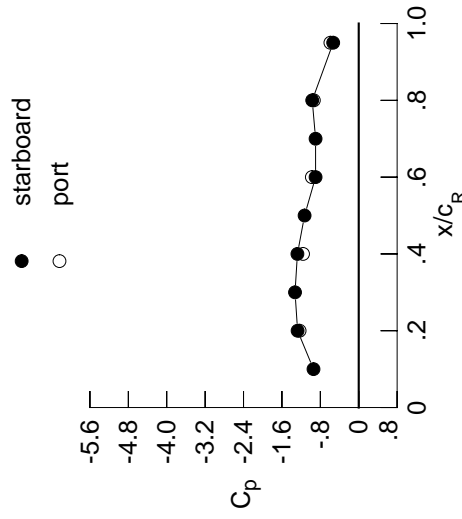

Table E4. Continued.

η	$x/c_R = .2$		$x/c_R = .4$		$x/c_R = .6$		$x/c_R = .8$		$x/c_R = .95$	
	$C_{p,u}$	$C_{p,l}$	$C_{p,u}$	$C_{p,l}$	$C_{p,u}$	$C_{p,l}$	$C_{p,u}$	$C_{p,l}$	$C_{p,u}$	$C_{p,l}$
0.050	-0.2464	-0.2816	-0.0840	*****	*****	*****	*****	*****	*****	*****
0.100	-0.2303	-0.2826	-0.0935	*****	*****	*****	*****	*****	*****	*****
0.150	-0.2617	-0.2860	-0.1065	*****	*****	*****	*****	*****	*****	*****
0.200	-0.2806	-0.2801	-0.1190	*****	*****	*****	*****	*****	*****	*****
0.250	*****	-0.2901	-0.1430	-0.3777	-0.3571	*****	*****	*****	*****	*****
0.300	-0.3222	-0.3128	-0.1700	-0.3675	-0.4013	*****	*****	*****	*****	*****
0.350	*****	-0.3411	-0.1933	-0.3540	-0.4123	*****	*****	*****	*****	*****
0.400	-0.3628	-0.3641	-0.1984	-0.3372	-0.4567	*****	*****	*****	*****	*****
0.450	-0.3773	-0.3968	-0.1845	-0.3224	-0.5670	*****	*****	*****	*****	*****
0.500	-0.3936	-0.3911	-0.2011	-0.3128	-0.6390	*****	*****	*****	*****	*****
0.525	*****	-0.3982	-0.2131	-0.3221	-0.6614	*****	*****	*****	*****	*****
0.550	-0.4215	-0.4042	-0.2523	-0.3506	-0.6805	*****	*****	*****	*****	*****
0.575	*****	-0.4100	-0.3344	-0.4205	-0.7467	*****	*****	*****	*****	*****
0.600	-0.4583	-0.4203	-0.5485	-0.5469	-0.8414	*****	*****	*****	*****	*****
0.625	*****	*****	-0.7260	-0.7298	-0.9854	*****	*****	*****	*****	*****
0.650	-0.5008	-0.5382	-0.9259	-0.9475	-1.1383	*****	*****	*****	*****	*****
0.675	*****	-0.7181	-1.0737	-1.1409	-1.2576	*****	*****	*****	*****	*****
0.700	-0.6012	-0.9106	-1.1473	-1.2739	-1.0909	*****	*****	*****	*****	*****
0.725	*****	-1.0078	*****	-1.3413	-0.9173	*****	*****	*****	*****	*****
0.750	-0.6404	-1.0551	*****	-1.2704	-0.8464	*****	*****	*****	*****	*****
0.775	*****	-1.1119	-1.0808	-1.1364	-0.7377	*****	*****	*****	*****	*****
0.800	-0.6400	-1.1621	-1.0502	-1.0098	*****	*****	*****	*****	*****	*****
0.825	*****	-1.1937	-1.0460	-0.9340	-0.5731	*****	*****	*****	*****	*****
0.850	-1.1930	-1.1946	-1.0404	-0.8807	-0.5145	*****	*****	*****	*****	*****
0.875	*****	-1.1428	-1.0101	-0.8532	-0.5215	*****	*****	*****	*****	*****
0.900	-1.3338	-1.0452	-0.9546	-0.8332	-0.5106	*****	*****	*****	*****	*****
0.925	*****	-1.0032	-0.9052	-0.7777	-0.5110	*****	*****	*****	*****	*****
0.950	-1.3254	-1.2055	-0.8723	-0.7285	-0.4637	*****	*****	*****	*****	*****
0.975	*****	-1.2539	-0.8409	-0.6619	-0.3947	*****	*****	*****	*****	*****
1.000	-1.2737	-1.2775	-0.8989	-0.9686	-0.5317	*****	*****	*****	*****	*****
-0.200	$C_{p,l}$	0.3100	0.2927	0.3057	*****	*****	*****	*****	*****	*****
-0.400		0.3109	0.2986	0.2781	0.1066	-0.6524	*****	*****	*****	*****
-0.600		0.3301	0.3024	0.2777	0.1393	-0.6344	*****	*****	*****	*****
-0.700		0.3448	0.3102	0.2778	0.1554	-0.6018	*****	*****	*****	*****
-0.800		0.3560	0.3243	0.2849	0.1797	-0.5296	*****	*****	*****	*****
-0.850		*****	0.3326	0.2923	0.1887	-0.5175	*****	*****	*****	*****
-0.900		*****	0.3263	0.2939	0.2045	-0.4723	*****	*****	*****	*****
-0.950		0.2454	0.2600	0.2545	0.1974	-0.1606	*****	*****	*****	*****
-0.975		*****	0.1276	0.1500	0.1280	-0.0496	*****	*****	*****	*****
-1.000		-1.2318	-1.1599	-0.9769	-0.9351	-0.5900	*****	*****	*****	*****

Medium Radius L.E.
 Run No. = 12, Point No. = 255
 $C_N = 0.697$, $C_m = -0.1353$
 $\alpha = 14.2^\circ$, $M_\infty = 0.849$
 $R_{mac} = 35.8 \times 10^6$

Leading Edge Pressures



x/c_R	starb'd C_p	port C_p
0.10	-0.9424	*****
0.20	-1.2737	-1.2318
0.30	-1.3269	*****
0.40	-1.2775	-1.1599
0.50	-1.1283	*****
0.60	-0.8989	-0.9769
0.70	-0.8990	*****
0.80	-0.9686	-0.9351
0.90	-0.0975	*****
0.95	-0.5317	-0.5900

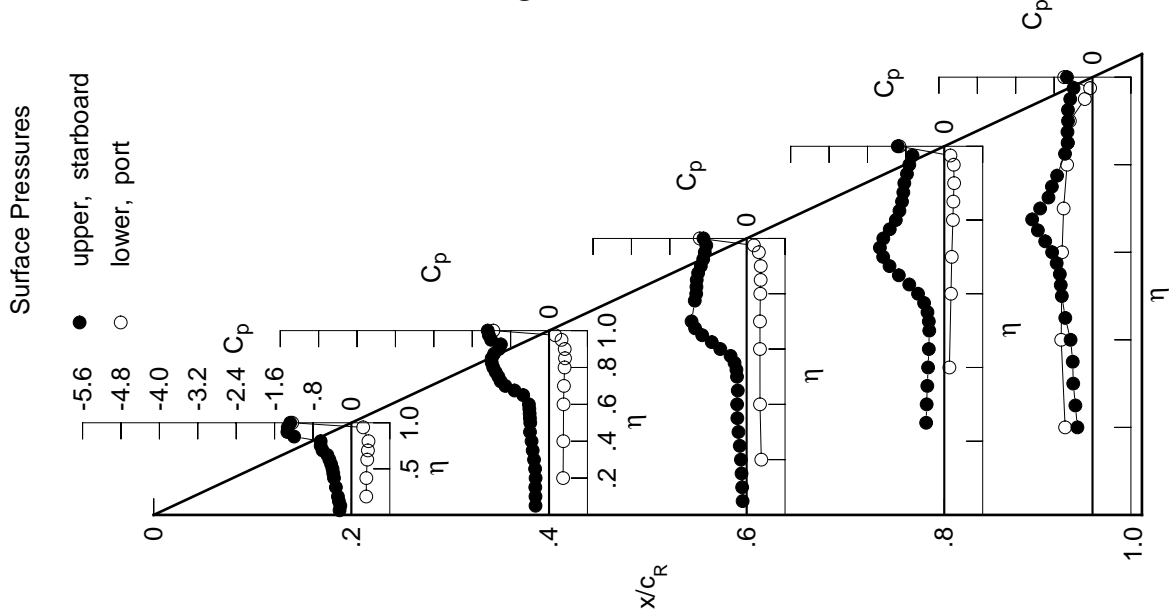

Table E4. Continued.

η	$x/c_R = 0.2$		$x/c_R = 0.4$		$x/c_R = 0.6$		$x/c_R = 0.8$		$x/c_R = 0.95$	
	$C_{p,u}$	$C_{p,u}$	$C_{p,u}$	$C_{p,u}$	$C_{p,u}$	$C_{p,u}$	$C_{p,u}$	$C_{p,u}$	$C_{p,u}$	$C_{p,u}$
0.050	-0.3139	-0.3576	-0.1235	*****	*****	*****	*****	*****	*****	*****
0.100	-0.2904	-0.3592	-0.1345	*****	*****	*****	*****	*****	*****	*****
0.150	-0.3232	-0.3523	-0.1451	*****	*****	*****	*****	*****	*****	*****
0.200	-0.3310	-0.3521	-0.1646	*****	*****	*****	*****	*****	*****	*****
0.250	*****	-0.3801	-0.1906	-0.4480	-0.4819	*****	*****	*****	*****	*****
0.300	-0.4257	-0.3769	-0.1905	-0.4324	-0.4096	*****	*****	*****	*****	*****
0.350	*****	-0.3704	-0.1983	-0.4137	-0.4884	*****	*****	*****	*****	*****
0.400	-0.4415	-0.3562	-0.2051	-0.3981	-0.6334	*****	*****	*****	*****	*****
0.450	-0.4529	-0.3554	-0.2029	-0.4012	-0.6937	*****	*****	*****	*****	*****
0.500	-0.4673	-0.4143	-0.3102	-0.4445	-0.7285	*****	*****	*****	*****	*****
0.525	*****	-0.5426	-0.4199	-0.5066	-0.7711	*****	*****	*****	*****	*****
0.550	-0.4868	-0.6862	-0.5867	-0.6037	-0.8358	*****	*****	*****	*****	*****
0.575	*****	-0.8323	-0.7766	-0.7520	-0.9466	*****	*****	*****	*****	*****
0.600	-0.4987	-0.9832	-1.0145	-0.9214	-1.0653	*****	*****	*****	*****	*****
0.625	*****	*****	-1.1722	-1.0956	-1.1495	*****	*****	*****	*****	*****
0.650	-0.6049	-1.2327	-1.3020	-1.2531	-0.7666	*****	*****	*****	*****	*****
0.675	*****	-1.3045	-1.3999	-1.3795	-0.7364	*****	*****	*****	*****	*****
0.700	-1.0169	-1.3307	-1.4351	-1.4426	-0.7093	*****	*****	*****	*****	*****
0.725	*****	-1.3214	*****	-1.1806	-0.6546	*****	*****	*****	*****	*****
0.750	-1.0195	-1.3078	*****	-1.1346	-0.5962	*****	*****	*****	*****	*****
0.775	*****	-1.2785	-1.1862	-1.1422	-0.5490	*****	*****	*****	*****	*****
0.800	-1.1218	-1.2254	-1.1388	-1.1346	*****	*****	*****	*****	*****	*****
0.825	*****	-1.1789	-1.1017	-1.0822	-0.5119	*****	*****	*****	*****	*****
0.850	-1.4232	-1.1494	-1.0515	-1.0564	-0.4896	*****	*****	*****	*****	*****
0.875	*****	-1.1114	-1.0149	-1.0003	-0.5152	*****	*****	*****	*****	*****
0.900	-1.3723	-1.0632	-0.9797	-0.8931	-0.5225	*****	*****	*****	*****	*****
0.925	*****	-1.0515	-0.9324	-0.7989	-0.5418	*****	*****	*****	*****	*****
0.950	-1.2967	-1.1397	-0.8774	-0.7903	-0.4818	*****	*****	*****	*****	*****
0.975	*****	-1.1584	-0.8493	-0.7432	-0.4176	*****	*****	*****	*****	*****
1.000	-1.3640	-1.1580	-0.8913	-0.9500	-0.5153	*****	*****	*****	*****	*****
-0.200	$C_{p,l}$	$C_{p,l}$	$C_{p,l}$	$C_{p,l}$	$C_{p,l}$	$C_{p,l}$	$C_{p,l}$	$C_{p,l}$	$C_{p,l}$	$C_{p,l}$
-0.400	0.3635	0.3364	0.3384	*****	-0.5584	*****	*****	*****	*****	*****
-0.600	0.3661	0.3413	0.3121	0.1337	-0.6392	*****	*****	*****	*****	*****
-0.700	0.3845	0.3478	0.3097	0.1670	-0.6195	*****	*****	*****	*****	*****
-0.800	0.3946	0.3532	0.3113	0.1796	-0.5862	*****	*****	*****	*****	*****
-0.850	0.3957	0.3631	0.3153	0.2028	-0.5100	*****	*****	*****	*****	*****
-0.900	*****	0.3647	0.3184	0.2107	-0.4934	*****	*****	*****	*****	*****
-0.950	*****	0.3462	0.3101	0.2201	-0.4426	*****	*****	*****	*****	*****
-0.975	0.2308	0.2544	0.2449	0.1921	-0.1480	*****	*****	*****	*****	*****
-1.000	*****	0.0953	0.1142	0.0956	-0.0556	*****	*****	*****	*****	*****
	-1.3160	-1.0697	-0.9605	-0.9437	-0.5061	*****	*****	*****	*****	*****

Medium Radius L.E.

Run No. = 12, Point No. = 256

$C_N = 0.806$, $C_m = -0.1472$

$\alpha = 16.3^\circ$, $M_\infty = 0.849$

$R_{mac} = 35.7 \times 10^6$

Leading Edge Pressures

● starboard
○ port

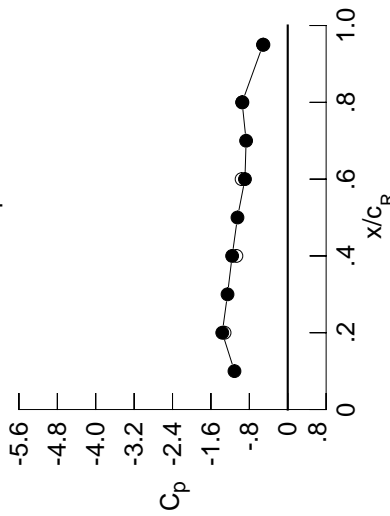

x/c_R	starb'd C_p	port C_p
0.10	-1.1097	*****
0.20	-1.3640	-1.3160
0.30	-1.2543	*****
0.40	-1.1580	-1.0697
0.50	-1.0469	*****
0.60	-0.8913	-0.9605
0.70	-0.8672	*****
0.80	-0.9500	-0.9437
0.90	-0.0619	*****
0.95	-0.5153	-0.5061

Surface Pressures

● upper, starboard
○ lower, port

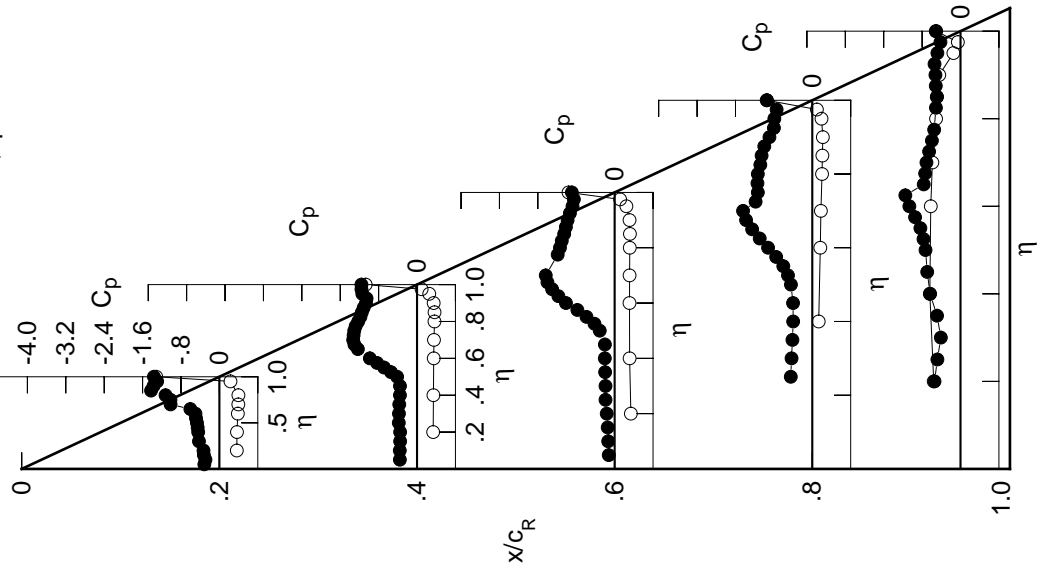
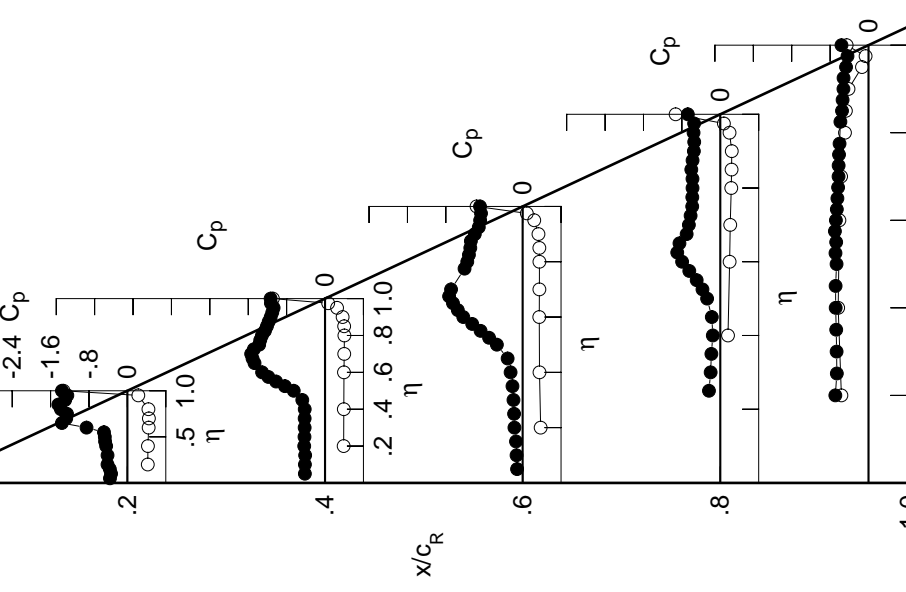
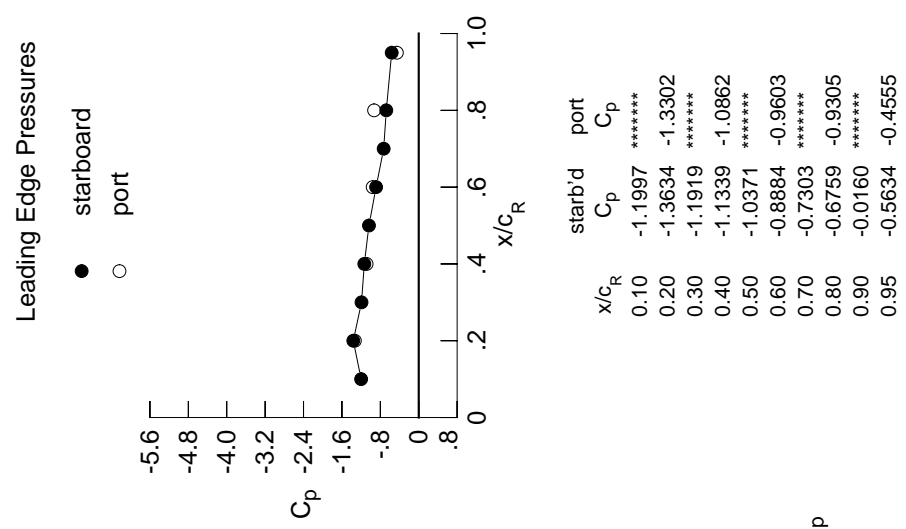

Table E4. Continued.

η	$x/c_R = 0.2$		$x/c_R = 0.4$		$x/c_R = 0.6$		$x/c_R = 0.8$		$x/c_R = 0.95$	
	$C_{p,u}$	$C_{p,l}$	$C_{p,u}$	$C_{p,l}$	$C_{p,u}$	$C_{p,l}$	$C_{p,u}$	$C_{p,l}$	$C_{p,u}$	$C_{p,l}$
0.050	-0.3630	-0.4203	-0.1158	*****	*****	*****	*****	*****	*****	*****
0.100	-0.3399	-0.4192	-0.1271	*****	*****	*****	*****	*****	*****	*****
0.150	-0.3659	-0.4147	-0.1387	*****	*****	*****	*****	*****	*****	*****
0.200	-0.4145	-0.4332	-0.1711	*****	*****	*****	*****	*****	-0.6911	*****
0.250	*****	-0.4277	-0.1787	-0.2361	-0.6597	*****	*****	*****	-0.6597	*****
0.300	-0.4133	-0.4252	-0.1915	-0.2009	-0.6646	*****	*****	*****	-0.6646	*****
0.350	*****	-0.4248	-0.2123	-0.1856	-0.6730	*****	*****	*****	-0.6730	*****
0.400	-0.4422	-0.4229	-0.2511	-0.1556	-0.6844	*****	*****	*****	-0.6844	*****
0.450	-0.4650	-0.4735	-0.3129	-0.1769	-0.6855	*****	*****	*****	-0.6855	*****
0.500	-0.4707	-0.6517	-0.5369	-0.2744	-0.6656	*****	*****	*****	-0.6656	*****
0.525	*****	-0.8358	-0.6993	-0.3715	-0.6876	*****	*****	*****	-0.6876	*****
0.550	-0.4877	-1.0189	-0.8763	-0.4919	-0.6739	*****	*****	*****	-0.6739	*****
0.575	-0.8514	-1.3109	-1.2368	-0.7952	-0.6791	*****	*****	*****	-0.6791	*****
0.600	*****	*****	-1.3506	-0.8968	-0.6603	*****	*****	*****	-0.6603	*****
0.625	-1.3637	-1.4684	-1.4515	-0.8500	-0.6482	*****	*****	*****	-0.6482	*****
0.650	*****	-1.5104	-1.5324	-0.7008	-0.6334	*****	*****	*****	-0.6334	*****
0.675	-1.2744	-1.5395	-1.4909	-0.6546	-0.6238	*****	*****	*****	-0.6238	*****
0.700	*****	-1.4840	*****	-0.6188	-0.6226	*****	*****	*****	-0.6226	*****
0.725	-1.2581	-1.3721	*****	-0.5845	-0.6145	*****	*****	*****	-0.6145	*****
0.750	*****	-1.3494	-1.2108	-0.5835	-0.6034	*****	*****	*****	-0.6034	*****
0.775	-1.3856	-1.3144	-1.1538	-0.5784	*****	*****	*****	*****	-0.5784	*****
0.800	*****	-1.2522	-1.1196	-0.5796	-0.5857	*****	*****	*****	-0.5857	*****
0.825	-1.4388	-1.2105	-1.0902	-0.6038	-0.5522	*****	*****	*****	-0.5522	*****
0.850	*****	-1.1738	-1.0785	-0.5779	-0.5403	*****	*****	*****	-0.5403	*****
0.875	-1.2965	-1.1319	-0.9972	-0.5503	-0.5225	*****	*****	*****	-0.5225	*****
0.900	*****	-1.0993	-0.9138	-0.5435	-0.5199	*****	*****	*****	-0.5199	*****
0.925	-1.2509	-1.0712	-0.8854	-0.5569	-0.4677	*****	*****	*****	-0.4677	*****
0.950	*****	-1.1271	-0.8669	-0.5450	-0.4376	*****	*****	*****	-0.4376	*****
0.975	-1.3634	-1.1339	-0.8884	-0.6759	-0.5634	*****	*****	*****	-0.5634	*****
1.000	*****	*****	*****	*****	*****	*****	*****	*****	*****	*****
-0.200	0.4248	0.3879	0.3754	*****	-0.5648	*****	*****	*****	-0.5648	*****
-0.400	0.4277	0.3911	0.3511	0.1605	-0.6320	*****	*****	*****	-0.6320	*****
-0.600	0.4429	0.3945	0.3462	0.1947	-0.6061	*****	*****	*****	-0.6061	*****
-0.700	0.4480	0.3997	0.3489	0.2072	-0.5712	*****	*****	*****	-0.5712	*****
-0.800	0.4385	0.4029	0.3498	0.2286	-0.4900	*****	*****	*****	-0.4900	*****
-0.850	*****	0.3984	0.3482	0.2353	-0.4709	*****	*****	*****	-0.4709	*****
-0.900	*****	0.3667	0.3300	0.2391	-0.4169	*****	*****	*****	-0.4169	*****
-0.950	0.2270	0.2507	0.2412	0.1926	-0.1364	*****	*****	*****	-0.1364	*****
-0.975	*****	0.0658	0.0868	0.0752	-0.0612	*****	*****	*****	-0.0612	*****
-1.000	-1.3302	-1.0862	-0.9603	-0.9305	-0.4555	*****	*****	*****	-0.4555	*****

Medium Radius L.E.
 Run No. = 12, Point No. = 257
 $C_N = 0.850$, $C_m = -0.1345$
 $\alpha = 18.3^\circ$, $M_\infty = 0.849$
 $R_{mac} = 35.9 \times 10^6$



x/c_R	starb'd C_p	port C_p
0.10	-1.1997	*****
0.20	-1.3634	-1.3302
0.30	-1.1919	*****
0.40	-1.1339	-1.0862
0.50	-1.0371	*****
0.60	-0.8884	-0.9603
0.70	-0.7303	*****
0.80	-0.6759	-0.9305
0.90	-0.0160	*****
0.95	-0.5634	-0.4555

Table E4. Continued.

η	$x/c_R = .2$		$x/c_R = .4$		$x/c_R = .6$		$x/c_R = .8$		$x/c_R = .95$	
	$C_{p,u}$	$C_{p,u}$	$C_{p,u}$	$C_{p,u}$	$C_{p,u}$	$C_{p,u}$	$C_{p,u}$	$C_{p,u}$	$C_{p,u}$	$C_{p,u}$
0.050	-0.4250	-0.4892	-0.0762	*****	*****	*****	*****	*****	*****	*****
0.100	-0.3892	-0.4869	-0.0832	*****	*****	*****	*****	*****	*****	*****
0.150	-0.4587	-0.4926	-0.0926	*****	*****	*****	*****	*****	*****	*****
0.200	-0.4625	-0.5061	-0.1193	*****	*****	*****	*****	*****	*****	*****
0.250	*****	-0.5087	-0.1289	-0.4455	-0.5025	*****	*****	*****	*****	*****
0.300	-0.4566	-0.5110	-0.1492	-0.4615	-0.5288	*****	*****	*****	*****	*****
0.350	*****	-0.5286	-0.1860	-0.5117	-0.5885	*****	*****	*****	*****	*****
0.400	-0.4771	-0.5705	-0.2675	-0.5692	-0.6671	*****	*****	*****	*****	*****
0.450	-0.4872	-0.7060	-0.3956	-0.6654	-0.7230	*****	*****	*****	*****	*****
0.500	-0.5608	-0.9487	-0.6819	-0.7781	-0.7121	*****	*****	*****	*****	*****
0.525	*****	-1.1056	-0.8557	-0.8266	-0.7234	*****	*****	*****	*****	*****
0.550	-0.9805	-1.2594	-1.0195	-0.8537	-0.6982	*****	*****	*****	*****	*****
0.575	*****	-1.3847	-1.1690	-0.8725	-0.7081	*****	*****	*****	*****	*****
0.600	-1.4249	-1.4792	-1.3264	-0.8786	-0.6946	*****	*****	*****	*****	*****
0.625	*****	*****	-1.4211	-0.8762	-0.6982	*****	*****	*****	*****	*****
0.650	-1.5987	-1.6299	-1.4004	-0.8687	-0.6900	*****	*****	*****	*****	*****
0.675	*****	-1.6776	-1.1740	-0.8486	-0.6771	*****	*****	*****	*****	*****
0.700	-1.5177	-1.6531	-1.1371	-0.8184	-0.6666	*****	*****	*****	*****	*****
0.725	*****	-1.5227	*****	-0.7852	-0.6560	*****	*****	*****	*****	*****
0.750	-1.4251	-1.4696	*****	-0.7454	-0.6356	*****	*****	*****	*****	*****
0.775	*****	-1.4099	-1.0781	-0.7304	-0.6186	*****	*****	*****	*****	*****
0.800	-1.5089	-1.3635	-1.1005	-0.7266	*****	*****	*****	*****	*****	*****
0.825	*****	-1.3482	-1.1828	-0.7139	-0.5835	*****	*****	*****	*****	*****
0.850	-1.4363	-1.3087	-1.1058	-0.7297	-0.5545	*****	*****	*****	*****	*****
0.875	*****	-1.2283	-0.9458	-0.7411	-0.5338	*****	*****	*****	*****	*****
0.900	-1.2723	-1.1757	-0.8619	-0.7629	-0.5036	*****	*****	*****	*****	*****
0.925	*****	-1.1430	-0.8548	-0.7877	-0.4781	*****	*****	*****	*****	*****
0.950	-1.2629	-1.1121	-0.8401	-0.8112	-0.4350	*****	*****	*****	*****	*****
0.975	*****	-1.1614	-0.8087	-0.7872	-0.3979	*****	*****	*****	*****	*****
1.000	-1.3870	-1.1864	-0.8098	-0.8944	-0.4443	*****	*****	*****	*****	*****
-0.200	$C_{p,l}$	$C_{p,l}$	$C_{p,l}$	$C_{p,l}$	$C_{p,l}$	$C_{p,l}$	$C_{p,l}$	$C_{p,l}$	$C_{p,l}$	$C_{p,l}$
-0.400	0.4829	0.4368	0.4159	*****	*****	*****	*****	*****	*****	*****
-0.600	0.4867	0.4399	0.3890	0.1928	-0.6125	*****	*****	*****	*****	*****
-0.700	0.4974	0.4421	0.3846	0.2255	-0.5866	*****	*****	*****	*****	*****
-0.800	0.4973	0.4440	0.3825	0.2378	-0.5470	*****	*****	*****	*****	*****
-0.850	0.4757	0.4403	0.3804	0.2555	-0.4660	*****	*****	*****	*****	*****
-0.900	*****	0.4266	0.3728	0.2584	-0.4463	*****	*****	*****	*****	*****
-0.950	*****	0.3807	0.3418	0.2540	-0.3900	*****	*****	*****	*****	*****
-0.975	0.2150	0.2401	0.2260	0.1836	-0.1291	*****	*****	*****	*****	*****
-1.000	*****	0.0286	0.0446	0.0385	-0.0769	*****	*****	*****	*****	*****
-1.000	-1.3189	-1.1102	-1.0436	-1.0078	-0.4601	*****	*****	*****	*****	*****

Medium Radius L.E.
 Run No. = 12, Point No. = 258
 $C_N = 0.965$, $C_m = -0.1679$
 $\alpha = 20.4^\circ$, $M_\infty = 0.848$
 $R_{mac} = 36.1 \times 10^6$

Leading Edge Pressures

● starboard
 ○ port

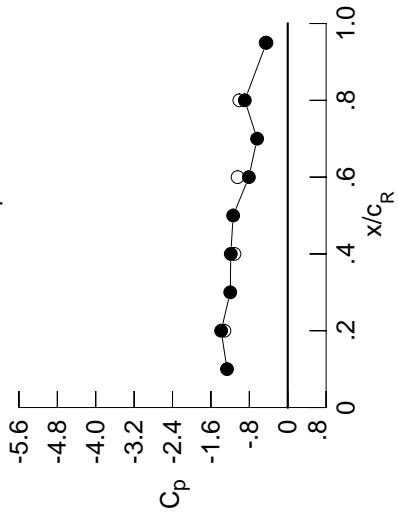

x/c_R	starb'd C_p	port C_p
0.10	-1.2645	*****
0.20	-1.3870	-1.3189
0.30	-1.1975	*****
0.40	-1.1864	-1.1102
0.50	-1.1365	*****
0.60	-0.8098	-1.0436
0.70	-0.6374	*****
0.80	-0.8944	-1.0078
0.90	-0.0177	*****
0.95	-0.4443	-0.4601

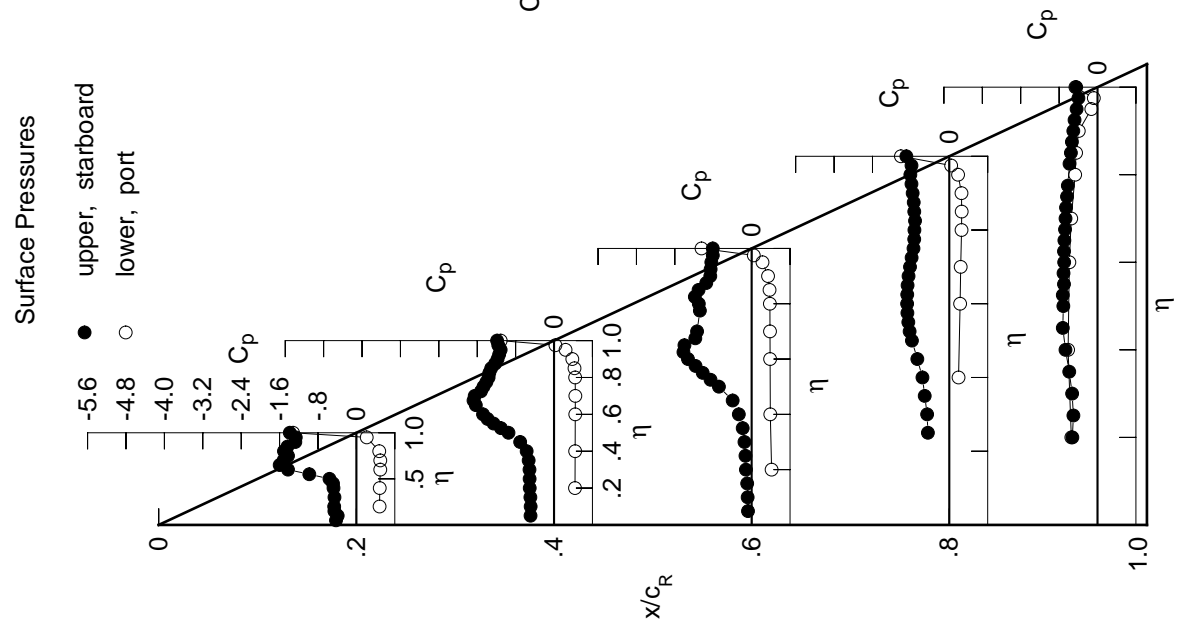

Table E4. Continued.

η	$x/c_R = .2$		$x/c_R = .4$		$x/c_R = .6$		$x/c_R = .8$		$x/c_R = .95$	
	$C_{p,u}$	$C_{p,u}$	$C_{p,u}$	$C_{p,u}$	$C_{p,u}$	$C_{p,u}$	$C_{p,u}$	$C_{p,u}$	$C_{p,u}$	$C_{p,u}$
0.050	-0.4941	-0.5740	-0.1351	*****	*****	*****	*****	*****	*****	*****
0.100	-0.4483	-0.5704	-0.1400	*****	*****	*****	*****	*****	*****	*****
0.150	-0.5271	-0.5658	-0.1452	*****	*****	*****	*****	*****	*****	*****
0.200	-0.5239	-0.5882	-0.1531	*****	*****	*****	*****	*****	*****	-0.5791
0.250	*****	-0.5927	-0.1743	-0.6340	-0.6075	*****	*****	*****	*****	*****
0.300	-0.5195	-0.6135	-0.2234	-0.6589	-0.6458	*****	*****	*****	*****	*****
0.350	*****	-0.6614	-0.2772	-0.7202	-0.6981	*****	*****	*****	*****	*****
0.400	-0.5594	-0.7548	-0.4041	-0.7666	-0.7464	*****	*****	*****	*****	*****
0.450	-0.6529	-0.9366	-0.5744	-0.8359	-0.7527	*****	*****	*****	*****	*****
0.500	-0.9426	-1.1655	-0.9007	-0.8804	-0.7232	*****	*****	*****	*****	*****
0.525	*****	-1.2879	-1.0592	-0.8989	-0.7371	*****	*****	*****	*****	*****
0.550	-1.3539	-1.4153	-1.1903	-0.9027	-0.7210	*****	*****	*****	*****	*****
0.575	*****	-1.5124	-1.3105	-0.9178	-0.7361	*****	*****	*****	*****	*****
0.600	-1.6268	-1.5974	-1.4381	-0.9294	-0.7266	*****	*****	*****	*****	*****
0.625	*****	*****	-1.3466	-0.9252	-0.7334	*****	*****	*****	*****	*****
0.650	-1.7623	-1.5479	-1.1368	-0.9088	-0.7266	*****	*****	*****	*****	*****
0.675	*****	-1.4783	-1.0857	-0.8836	-0.7118	*****	*****	*****	*****	*****
0.700	-1.6368	-1.4726	-1.0522	-0.8567	-0.7009	*****	*****	*****	*****	*****
0.725	*****	-1.4706	*****	-0.8351	-0.6907	*****	*****	*****	*****	*****
0.750	-1.5006	-1.4780	*****	-0.8043	-0.6716	*****	*****	*****	*****	*****
0.775	*****	-1.4906	-0.9968	-0.7949	-0.6507	*****	*****	*****	*****	*****
0.800	-1.4856	-1.5152	-1.0198	-0.7860	*****	*****	*****	*****	*****	*****
0.825	*****	-1.4671	-1.0315	-0.7772	-0.6121	*****	*****	*****	*****	*****
0.850	-1.4163	-1.3478	-0.9368	-0.7831	-0.5856	*****	*****	*****	*****	*****
0.875	*****	-1.2633	-0.8464	-0.7825	-0.5652	*****	*****	*****	*****	*****
0.900	-1.3030	-1.2479	-0.8043	-0.7838	-0.5363	*****	*****	*****	*****	*****
0.925	*****	-1.2513	-0.7875	-0.7811	-0.5167	*****	*****	*****	*****	*****
0.950	-1.2718	-1.2471	-0.7759	-0.7859	-0.4741	*****	*****	*****	*****	*****
0.975	*****	-1.2570	-0.7392	-0.7685	-0.4362	*****	*****	*****	*****	*****
1.000	-1.3679	-1.2614	-0.7421	-0.8112	-0.4539	*****	*****	*****	*****	*****
	$C_{p,l}$	$C_{p,l}$	$C_{p,l}$	$C_{p,l}$	$C_{p,l}$	$C_{p,l}$	$C_{p,l}$	$C_{p,l}$	$C_{p,l}$	$C_{p,l}$
-0.200	0.5328	0.4786	0.4455	*****	*****	*****	*****	*****	*****	-0.5236
-0.400	0.5362	0.4795	0.4193	0.2227	-0.5872	*****	*****	*****	*****	*****
-0.600	0.5424	0.4787	0.4176	0.2504	-0.5648	*****	*****	*****	*****	*****
-0.700	0.5357	0.4790	0.4118	0.2603	-0.5240	*****	*****	*****	*****	*****
-0.800	0.5020	0.4675	0.4041	0.2770	-0.4426	*****	*****	*****	*****	*****
-0.850	*****	0.4455	0.3917	0.2761	-0.4208	*****	*****	*****	*****	*****
-0.900	*****	0.3852	0.3489	0.2627	-0.3657	*****	*****	*****	*****	*****
-0.950	0.1975	0.2199	0.2085	0.1721	-0.1248	*****	*****	*****	*****	*****
-0.975	*****	-0.0133	0.0052	0.0050	-0.0955	*****	*****	*****	*****	*****
-1.000	-1.3001	-1.2413	-1.1320	-1.0371	-0.4755	*****	*****	*****	*****	*****

Medium Radius L.E.
 Run No. = 12, Point No. = 259
 $C_N = 1.073$, $C_m = -0.1886$
 $\alpha = 22.4^\circ$, $M_\infty = 0.851$
 $R_{mac} = 36.1 \times 10^6$

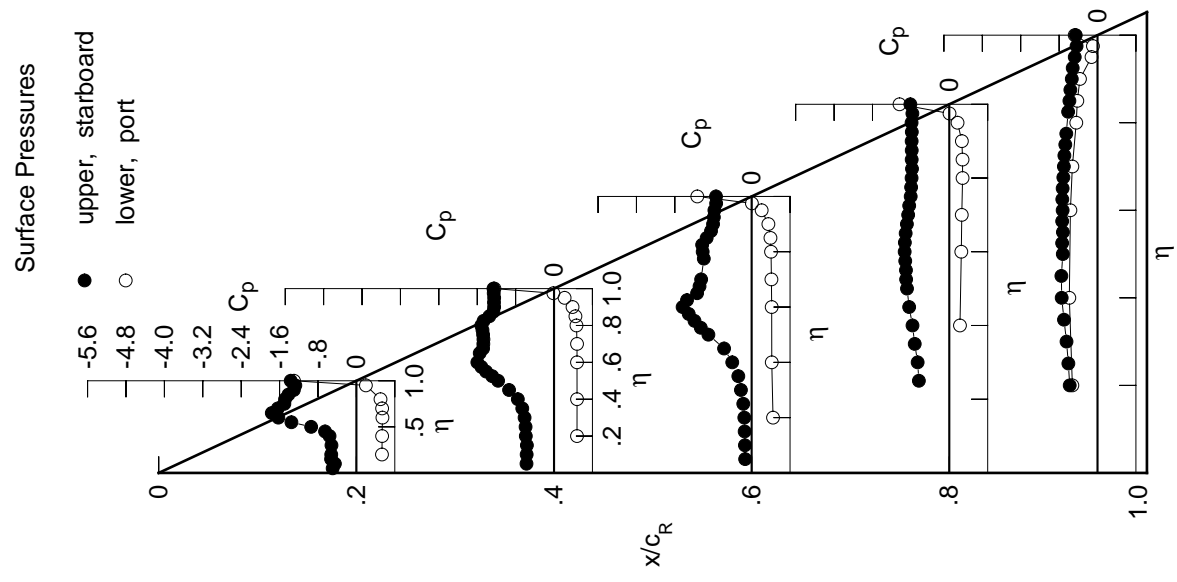
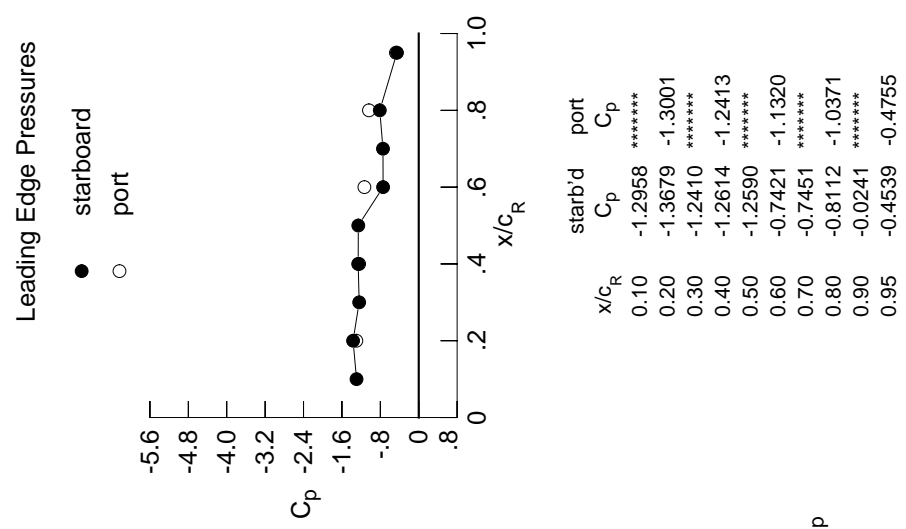

Table E4. Continued.

η	$x/c_R = .2$		$x/c_R = .4$		$x/c_R = .6$		$x/c_R = .8$		$x/c_R = .95$	
	$C_{p,u}$	$C_{p,u}$	$C_{p,u}$	$C_{p,u}$	$C_{p,u}$	$C_{p,u}$	$C_{p,u}$	$C_{p,u}$	$C_{p,u}$	$C_{p,u}$
0.050	-0.5801	-0.6476	-0.0078	*****	*****	*****	*****	*****	*****	*****
0.100	-0.5386	-0.6485	-0.0246	*****	*****	*****	*****	*****	*****	*****
0.150	-0.5891	-0.6512	-0.0368	*****	*****	*****	*****	*****	*****	*****
0.200	-0.6099	-0.6577	-0.0619	*****	*****	*****	*****	*****	*****	*****
0.250	*****	-0.6881	-0.1010	-0.7611	-0.7611	-0.6146	*****	*****	*****	*****
0.300	-0.6286	-0.7281	-0.1665	-0.7981	-0.6794	*****	*****	*****	*****	*****
0.350	*****	-0.8149	-0.2764	-0.8579	-0.7402	*****	*****	*****	*****	*****
0.400	-0.7464	-0.9398	-0.4595	-0.9070	-0.8137	*****	*****	*****	*****	*****
0.450	-0.9504	-1.1303	-0.6856	-0.9635	-0.8368	*****	*****	*****	*****	*****
0.500	-1.2744	-1.3246	-0.9933	-0.9845	-0.7958	*****	*****	*****	*****	*****
0.525	*****	-1.4284	-1.1329	-0.9875	-0.7967	*****	*****	*****	*****	*****
0.550	-1.5669	-1.5298	-1.2510	-0.9660	-0.7750	*****	*****	*****	*****	*****
0.575	*****	-1.6098	-1.3530	-0.9706	-0.7849	*****	*****	*****	*****	*****
0.600	-1.7437	-1.6771	-1.4529	-0.9663	-0.7715	*****	*****	*****	*****	*****
0.625	*****	*****	-1.3401	-0.9629	-0.7762	*****	*****	*****	*****	*****
0.650	-1.7297	-1.5292	-1.1654	-0.9563	-0.7696	*****	*****	*****	*****	*****
0.675	*****	-1.4843	-1.1084	-0.9356	-0.7563	*****	*****	*****	*****	*****
0.700	-1.6750	-1.4681	-1.0647	-0.9159	-0.7459	*****	*****	*****	*****	*****
0.725	*****	-1.4608	*****	-0.9020	-0.7337	*****	*****	*****	*****	*****
0.750	-1.6270	-1.4540	*****	-0.8813	-0.7148	*****	*****	*****	*****	*****
0.775	*****	-1.4879	-0.9723	-0.8773	-0.6960	*****	*****	*****	*****	*****
0.800	-1.4677	-1.5164	-0.9617	-0.8686	*****	*****	*****	*****	*****	*****
0.825	*****	-1.4565	-0.9770	-0.8631	-0.6571	*****	*****	*****	*****	*****
0.850	-1.4075	-1.3848	-0.9185	-0.8671	-0.6202	*****	*****	*****	*****	*****
0.875	*****	-1.3506	-0.8578	-0.8588	-0.5984	*****	*****	*****	*****	*****
0.900	-1.3490	-1.3512	-0.8004	-0.8475	-0.5693	*****	*****	*****	*****	*****
0.925	*****	-1.3557	-0.7624	-0.8302	-0.5580	*****	*****	*****	*****	*****
0.950	-1.3208	-1.3555	-0.7332	-0.8134	-0.5081	*****	*****	*****	*****	*****
0.975	*****	-1.3383	-0.7080	-0.8022	-0.4712	*****	*****	*****	*****	*****
1.000	-1.3890	-1.3529	-0.6935	-0.8176	-0.4622	*****	*****	*****	*****	*****
-0.200	$C_{p,l}$	$C_{p,l}$	$C_{p,l}$	$C_{p,l}$	$C_{p,l}$	$C_{p,l}$	$C_{p,l}$	$C_{p,l}$	$C_{p,l}$	$C_{p,l}$
-0.400	0.5896	0.5252	0.4858	*****	*****	*****	*****	*****	*****	*****
-0.600	0.5914	0.5273	0.4615	0.2506	-0.5761	*****	*****	*****	*****	*****
-0.700	0.5927	0.5254	0.4562	0.2821	-0.5523	*****	*****	*****	*****	*****
-0.800	0.5794	0.5207	0.4537	0.2886	-0.5129	*****	*****	*****	*****	*****
-0.850	0.5347	0.5012	0.4429	0.3032	-0.4345	*****	*****	*****	*****	*****
-0.900	*****	0.4715	0.4257	0.2994	-0.4184	*****	*****	*****	*****	*****
-0.950	0.1840	0.2104	0.2243	0.1809	-0.1428	*****	*****	*****	*****	*****
-0.975	*****	-0.0452	0.0152	0.0088	-0.1330	*****	*****	*****	*****	*****
-1.000	-1.3640	-1.3271	-0.6951	-0.8283	-0.5287	*****	*****	*****	*****	*****

Medium Radius L.E.
 Run No. = 12, Point No. = 260
 $C_N = 1.119$, $C_m = -0.1881$
 $\alpha = 24.4^\circ$, $M_\infty = 0.849$
 $R_{mac} = 35.9 \times 10^6$

Leading Edge Pressures

● starboard
 ○ port

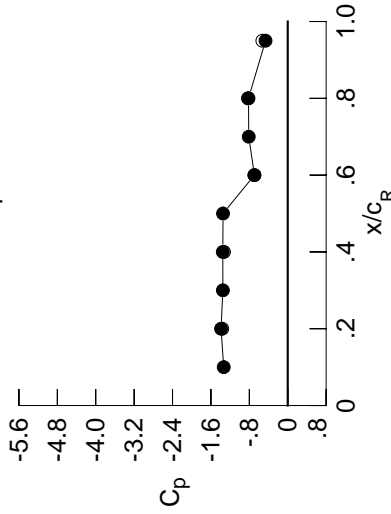

x/c_R	starb'd C_p	port C_p
0.10	-1.3338	*****
0.20	-1.3890	-1.3640
0.30	-1.3515	*****
0.40	-1.3529	-1.3271
0.50	-1.3478	*****
0.60	-0.6935	-0.6951
0.70	-0.8117	*****
0.80	-0.8176	-0.8283
0.90	-0.0219	*****
0.95	-0.4622	-0.5287

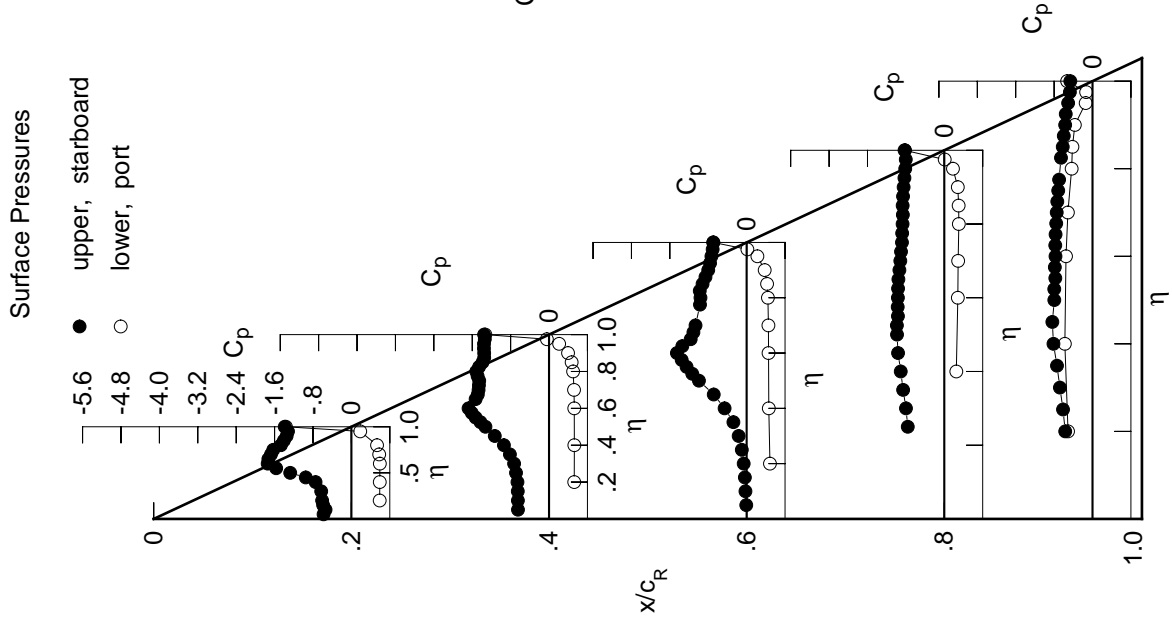

Table E4. Concluded.

η	x/c_R .2	x/c_R .4	x/c_R .6	x/c_R .8	x/c_R .95
	$C_{p,u}$	$C_{p,u}$	$C_{p,u}$	$C_{p,u}$	$C_{p,u}$
0.050	-0.6626	-0.7183	-0.0924	*****	*****
0.100	-0.6226	-0.7230	-0.0981	*****	*****
0.150	-0.6808	-0.7361	-0.1077	*****	*****
0.200	-0.6954	-0.7533	-0.1277	*****	-0.7248
0.250	*****	-0.7996	-0.1724	-1.0052	-0.8142
0.300	-0.7486	-0.8584	-0.2509	-0.9731	-0.8820
0.350	*****	-0.9575	-0.3809	-0.9378	-0.8716
0.400	-0.9877	-1.1016	-0.5846	-0.8665	-0.8229
0.450	-1.2442	-1.2826	-0.8108	-0.8242	-0.7643
0.500	-1.5086	-1.4474	-1.0760	-0.8265	-0.7387
0.525	*****	-1.5275	-1.1789	-0.8493	-0.7603
0.550	-1.6968	-1.6130	-1.2520	-0.8746	-0.7590
0.575	*****	-1.6705	-1.2988	-0.9191	-0.7840
0.600	-1.7950	-1.6829	-1.3227	-0.9534	-0.7826
0.625	*****	*****	-1.1634	-0.9590	-0.7917
0.650	-1.6634	-1.5437	-1.0408	-0.9595	-0.7865
0.675	*****	-1.5082	-1.0025	-0.9644	-0.7769
0.700	-1.6840	-1.4929	-0.9823	-0.9542	-0.7769
0.725	*****	-1.4945	*****	-0.9415	-0.7692
0.750	-1.6961	-1.5040	*****	-0.9108	-0.7535
0.775	*****	-1.5404	-0.9240	-0.9016	-0.7344
0.800	-1.4740	-1.5577	-0.8816	-0.8817	*****
0.825	*****	-1.5006	-0.8391	-0.8834	-0.6934
0.850	-1.4319	-1.4373	-0.8033	-0.8700	-0.6629
0.875	*****	-1.4101	-0.7922	-0.8514	-0.6402
0.900	-1.3997	-1.4097	-0.7830	-0.8343	-0.6148
0.925	*****	-1.4225	-0.7687	-0.8101	-0.5956
0.950	-1.3800	-1.4170	-0.7610	-0.7891	-0.5548
0.975	*****	-1.4086	-0.7597	-0.7609	-0.5098
1.000	-1.4214	-1.4141	-0.7488	-0.7583	-0.4831
	$C_{p,l}$	$C_{p,l}$	$C_{p,l}$	$C_{p,l}$	$C_{p,l}$
-0.200	0.6458	0.5728	0.5237	*****	-0.4876
-0.400	0.6442	0.5744	0.4987	0.2839	-0.5478
-0.600	0.6393	0.5675	0.4908	0.3104	-0.5239
-0.700	0.6175	0.5597	0.4848	0.3185	-0.4852
-0.800	0.5593	0.5309	0.4700	0.3276	-0.4056
-0.850	*****	0.4913	0.4461	0.3208	-0.3911
-0.900	*****	0.4042	0.3848	0.2947	-0.3429
-0.950	0.1635	0.1953	0.2123	0.1745	-0.1366
-0.975	*****	-0.0794	-0.0157	-0.0156	-0.1472
-1.000	-1.4448	-1.3894	-0.8115	-0.7665	-0.5292

Medium Radius L.E.

Run No. = 12, Point No. = 261

$C_N = 1.195$, $C_m = -0.1970$

$\alpha = 26.5^\circ$, $M_\infty = 0.849$

$R_{mac} = 35.5 \times 10^6$

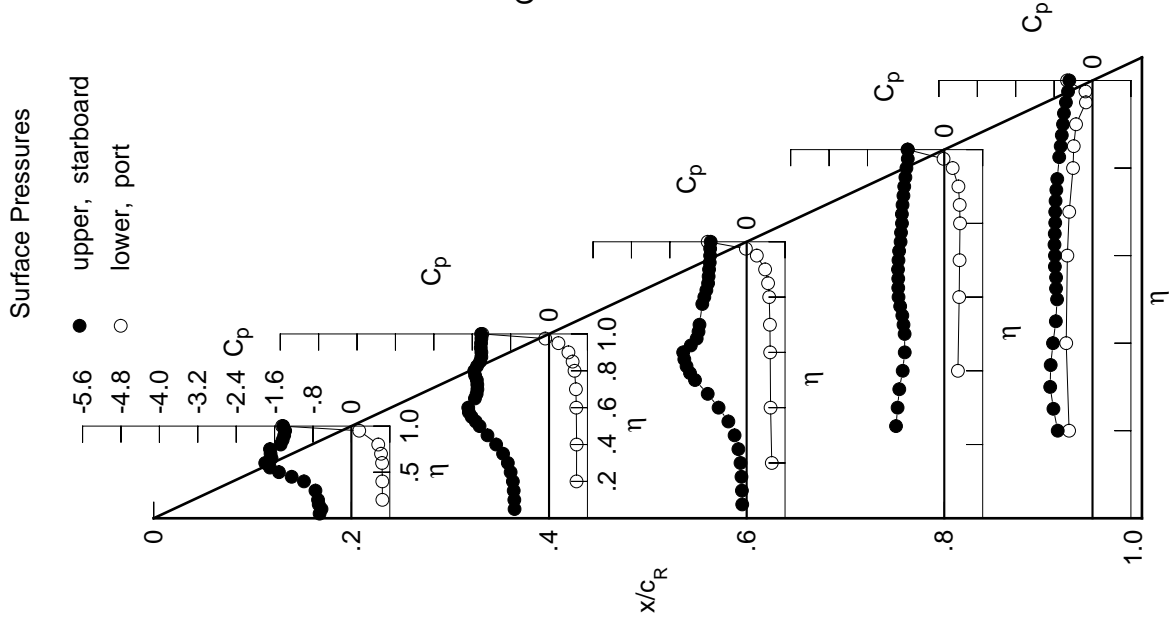

Leading Edge Pressures

● starboard
○ port

x/c_R	starb'd C_p	port C_p
0.10	-1.3655	*****
0.20	-1.4214	-1.4448
0.30	-1.4517	*****
0.40	-1.4141	-1.3894
0.50	-1.2661	*****
0.60	-0.7488	-0.8115
0.70	-0.9003	*****
0.80	-0.7583	-0.7665
0.90	0.0024	*****
0.95	-0.4831	-0.5292

Table E5. Tabulations and Plots of Surface Pressure Coefficients.

η	x/c_R .2	x/c_R .4	x/c_R .6	x/c_R .8	x/c_R .95
	$C_{p,u}$	$C_{p,u}$	$C_{p,u}$	$C_{p,u}$	$C_{p,u}$
0.050	0.0080	0.0190	0.1424	*****	*****
0.100	0.0181	0.0190	0.1328	*****	*****
0.150	0.0062	0.0205	0.1215	*****	*****
0.200	0.0045	0.0238	0.1083	*****	-0.3624
0.250	*****	0.0184	0.0962	-0.1192	-0.4685
0.300	-0.0039	0.0199	0.0851	-0.1045	-0.6170
0.350	*****	0.0157	0.0757	-0.0939	-0.6840
0.400	-0.0176	0.0166	0.0679	-0.0808	-0.6997
0.450	-0.0215	0.0129	0.0767	-0.0737	-0.6811
0.500	-0.0259	0.0162	0.0513	-0.0671	-0.6609
0.525	*****	0.0103	0.0491	-0.0667	-0.6681
0.550	-0.0278	0.0051	0.0471	-0.0623	-0.6639
0.575	*****	0.0049	0.0507	-0.0631	-0.6747
0.600	-0.0326	0.0014	0.0372	-0.0619	-0.6774
0.625	*****	*****	0.0390	-0.0571	-0.6898
0.650	-0.0301	0.0000	0.0336	-0.0584	-0.7050
0.675	*****	-0.0112	0.0273	-0.0583	-0.7094
0.700	-0.0250	-0.0176	0.0255	-0.0556	-0.7270
0.725	*****	-0.0225	*****	-0.0552	-0.7345
0.750	-0.0152	-0.0290	*****	-0.0544	-0.7290
0.775	*****	-0.0312	0.0057	-0.0582	-0.7174
0.800	0.0037	-0.0338	-0.0065	-0.0617	*****
0.825	*****	-0.0316	-0.0162	-0.0606	-0.7036
0.850	0.0264	-0.0262	-0.0249	-0.0796	-0.6875
0.875	*****	-0.0147	-0.0273	-0.0864	-0.7388
0.900	0.0628	-0.0029	-0.0225	-0.0926	-0.7741
0.925	*****	0.0204	-0.0083	-0.0839	-1.1417
0.950	0.1139	0.0563	0.0236	-0.0523	-0.3779
0.975	*****	0.1149	0.0826	0.0094	-0.1988
1.000	0.2155	0.2056	0.1751	0.1434	0.0620
	$C_{p,l}$	$C_{p,l}$	$C_{p,l}$	$C_{p,l}$	$C_{p,l}$
-0.200	-0.0325	-0.0074	0.0786	*****	-0.4646
-0.400	-0.0567	-0.0096	0.0369	-0.1075	-0.5945
-0.600	-0.0816	-0.0360	0.0061	-0.0876	-0.6639
-0.700	-0.0846	-0.0703	-0.0196	-0.0899	-0.6836
-0.800	-0.0723	*****	-0.0650	-0.1040	-0.7252
-0.850	*****	-0.1082	-0.1007	-0.1356	-0.7586
-0.900	*****	-0.0981	-0.1201	-0.1757	-0.5084
-0.950	0.0263	-0.0529	-0.0914	-0.1701	-0.4023
-0.975	*****	-0.0012	-0.0457	-0.1203	-0.2854
-1.000	0.1920	0.1764	0.1398	0.1243	0.0540

Medium Radius L.E.

Run No. = 13, Point No. = 262

$C_N = -0.022$, $C_m = -0.0057$

$\alpha = -0.8^\circ$, $M_\infty = 0.851$

$R_{mac} = 48.2 \times 10^6$

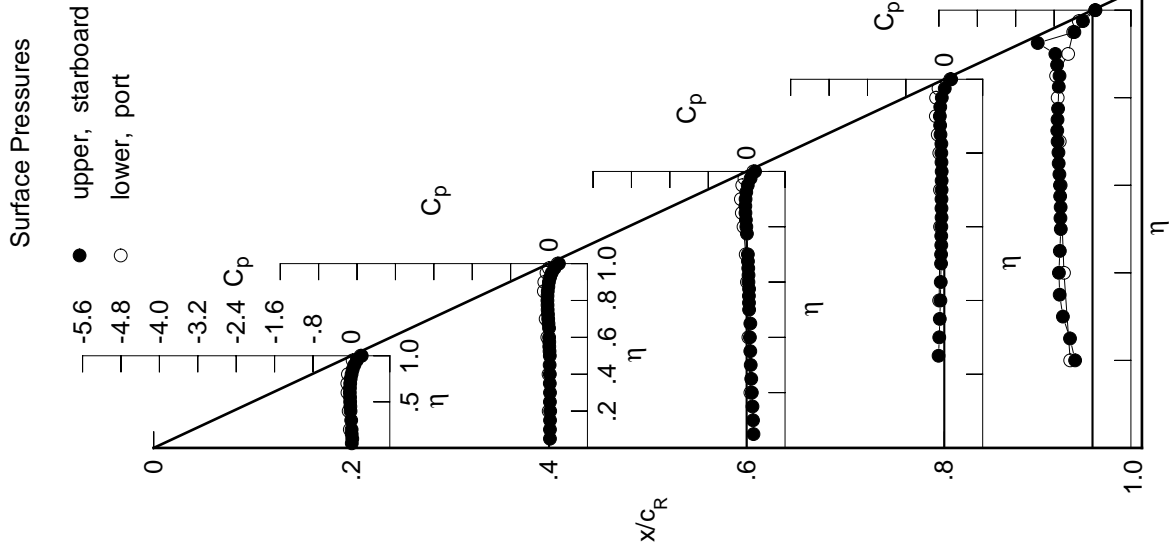

Leading Edge Pressures

- starboard
- port

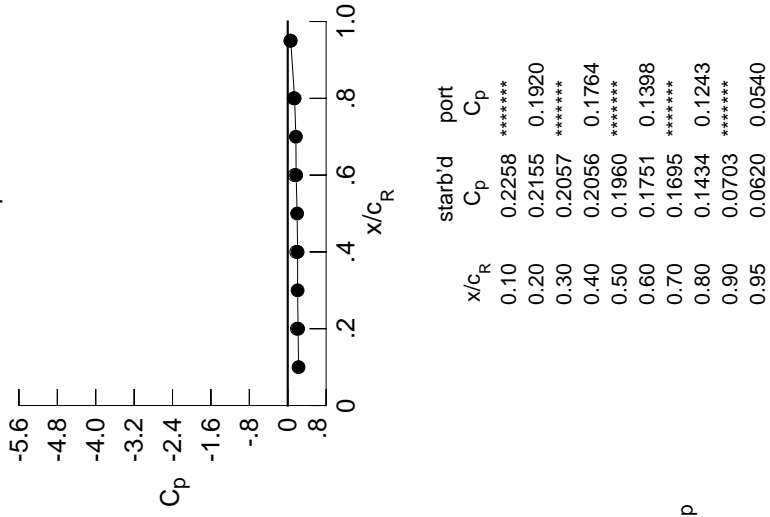

Table E5. Continued.

η	$x/c_R = .2$		$x/c_R = .4$		$x/c_R = .6$		$x/c_R = .8$		$x/c_R = .95$	
	$C_{p,u}$	$C_{p,u}$	$C_{p,u}$	$C_{p,u}$	$C_{p,u}$	$C_{p,u}$	$C_{p,u}$	$C_{p,u}$	$C_{p,u}$	$C_{p,u}$
0.050	0.0024	0.0145	0.1380	0.1380	0.1380	0.1380	0.1380	0.1380	0.1380	0.1380
0.100	0.0113	0.0142	0.1306	0.1306	0.1306	0.1306	0.1306	0.1306	0.1306	0.1306
0.150	0.0013	0.0156	0.1168	0.1168	0.1168	0.1168	0.1168	0.1168	0.1168	0.1168
0.200	-0.0021	0.0193	0.1054	0.1054	0.1054	0.1054	0.1054	0.1054	0.1054	0.1054
0.250	0.0000	0.0134	0.0930	0.0930	0.0930	0.0930	0.0930	0.0930	0.0930	0.0930
0.300	-0.0094	0.0149	0.0821	0.0821	0.0821	0.0821	0.0821	0.0821	0.0821	0.0821
0.350	0.0000	0.0107	0.0721	0.0721	0.0721	0.0721	0.0721	0.0721	0.0721	0.0721
0.400	-0.0251	0.0105	0.0642	0.0642	0.0642	0.0642	0.0642	0.0642	0.0642	0.0642
0.450	-0.0286	0.0066	0.0732	0.0732	0.0732	0.0732	0.0732	0.0732	0.0732	0.0732
0.500	-0.0337	0.0106	0.0458	0.0458	0.0458	0.0458	0.0458	0.0458	0.0458	0.0458
0.525	0.0000	0.0042	0.0457	0.0457	0.0457	0.0457	0.0457	0.0457	0.0457	0.0457
0.550	-0.0370	-0.0005	0.0415	0.0415	0.0415	0.0415	0.0415	0.0415	0.0415	0.0415
0.575	0.0000	-0.0038	0.0457	0.0457	0.0457	0.0457	0.0457	0.0457	0.0457	0.0457
0.600	-0.0416	-0.0047	0.0307	0.0307	0.0307	0.0307	0.0307	0.0307	0.0307	0.0307
0.625	0.0000	0.0000	0.0339	0.0339	0.0339	0.0339	0.0339	0.0339	0.0339	0.0339
0.650	-0.0402	-0.0060	0.0273	0.0273	0.0273	0.0273	0.0273	0.0273	0.0273	0.0273
0.675	0.0000	-0.0193	0.0211	0.0211	0.0211	0.0211	0.0211	0.0211	0.0211	0.0211
0.700	-0.0360	-0.0253	0.0193	0.0193	0.0193	0.0193	0.0193	0.0193	0.0193	0.0193
0.725	0.0000	-0.0332	0.0000	0.0000	0.0000	0.0000	0.0000	0.0000	0.0000	0.0000
0.750	-0.0269	-0.0386	0.0000	0.0000	0.0000	0.0000	0.0000	0.0000	0.0000	0.0000
0.775	0.0000	-0.0434	-0.0020	-0.0020	-0.0020	-0.0020	-0.0020	-0.0020	-0.0020	-0.0020
0.800	-0.0092	-0.0449	-0.0165	-0.0165	-0.0165	-0.0165	-0.0165	-0.0165	-0.0165	-0.0165
0.825	0.0000	-0.0458	-0.0265	-0.0265	-0.0265	-0.0265	-0.0265	-0.0265	-0.0265	-0.0265
0.850	0.0134	-0.0393	-0.0387	-0.0387	-0.0387	-0.0387	-0.0387	-0.0387	-0.0387	-0.0387
0.875	0.0000	-0.0305	-0.0404	-0.0404	-0.0404	-0.0404	-0.0404	-0.0404	-0.0404	-0.0404
0.900	0.0478	-0.0184	-0.0402	-0.0402	-0.0402	-0.0402	-0.0402	-0.0402	-0.0402	-0.0402
0.925	0.0000	0.0034	-0.0251	-0.0251	-0.0251	-0.0251	-0.0251	-0.0251	-0.0251	-0.0251
0.950	0.1002	0.0392	0.0036	0.0036	0.0036	0.0036	0.0036	0.0036	0.0036	0.0036
0.975	0.0000	0.0958	0.0626	0.0626	0.0626	0.0626	0.0626	0.0626	0.0626	0.0626
1.000	0.2220	0.2185	0.1976	0.1976	0.1976	0.1976	0.1976	0.1976	0.1976	0.1976
-0.200	$C_{p,l}$	$C_{p,l}$	$C_{p,l}$	$C_{p,l}$	$C_{p,l}$	$C_{p,l}$	$C_{p,l}$	$C_{p,l}$	$C_{p,l}$	$C_{p,l}$
-0.400	-0.0232	0.0005	0.0854	0.0854	0.0854	0.0854	0.0854	0.0854	0.0854	0.0854
-0.600	-0.0477	0.0001	0.0421	0.0421	0.0421	0.0421	0.0421	0.0421	0.0421	0.0421
-0.700	-0.0692	-0.0267	0.0161	0.0161	0.0161	0.0161	0.0161	0.0161	0.0161	0.0161
-0.800	-0.0716	-0.0587	-0.0094	-0.0094	-0.0094	-0.0094	-0.0094	-0.0094	-0.0094	-0.0094
-0.850	-0.0561	0.0000	-0.0516	-0.0516	-0.0516	-0.0516	-0.0516	-0.0516	-0.0516	-0.0516
-0.900	0.0000	-0.0894	-0.0838	-0.0838	-0.0838	-0.0838	-0.0838	-0.0838	-0.0838	-0.0838
-0.950	0.0463	-0.0273	-0.0651	-0.0651	-0.0651	-0.0651	-0.0651	-0.0651	-0.0651	-0.0651
-0.975	0.0000	0.0267	-0.0154	-0.0154	-0.0154	-0.0154	-0.0154	-0.0154	-0.0154	-0.0154
-1.000	0.2012	0.1929	0.1610	0.1610	0.1610	0.1610	0.1610	0.1610	0.1610	0.1610

Medium Radius L.E.
 Run No. = 13 , Point No. = 263
 $C_N = -0.006$, $C_m = -0.0100$
 $\alpha = -0.5^\circ$, $M_\infty = 0.850$
 $R_{mac} = 48.5 \times 10^6$

Leading Edge Pressures

- starboard
- port

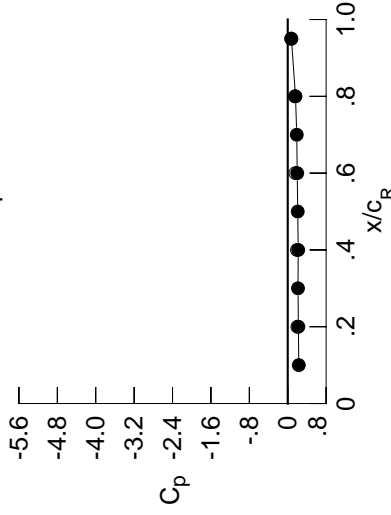

x/c_R	starb'd C_p	port C_p
0.10	0.2303	0.2303
0.20	0.2220	0.2220
0.30	0.2137	0.2137
0.40	0.2185	0.2185
0.50	0.2084	0.2084
0.60	0.1976	0.1976
0.70	0.1878	0.1878
0.80	0.1619	0.1619
0.90	0.0763	0.0763
0.95	0.0769	0.0769

Surface Pressures

- upper, starboard
- lower, port

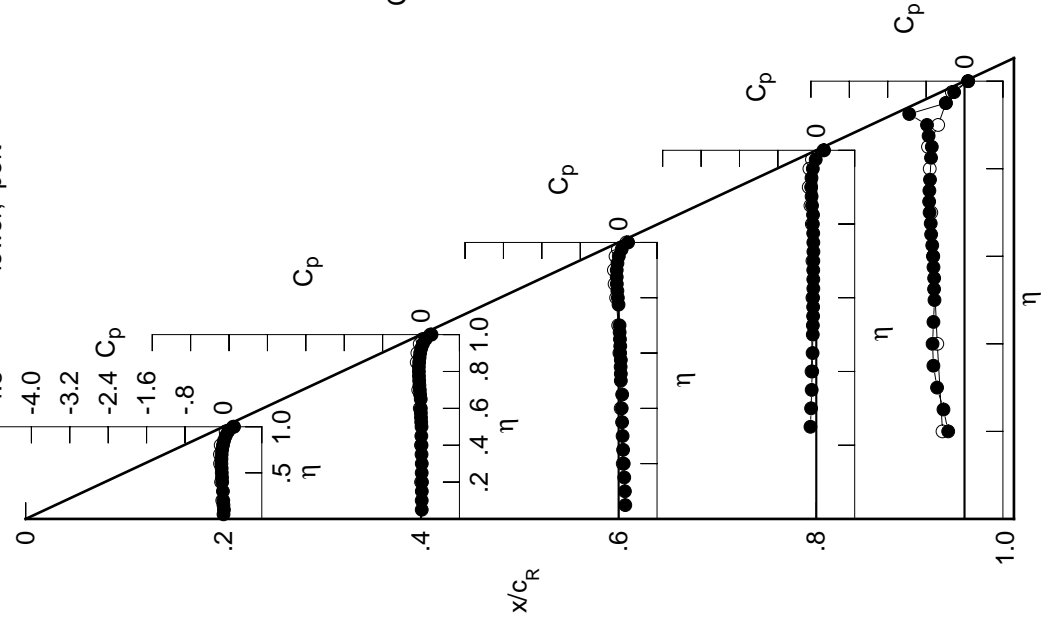

Table E5. Continued.

η	$x/c_R = .2$		$x/c_R = .4$		$x/c_R = .6$		$x/c_R = .8$		$x/c_R = .95$	
	$C_{p,u}$	$C_{p,u}$	$C_{p,u}$	$C_{p,u}$	$C_{p,u}$	$C_{p,u}$	$C_{p,u}$	$C_{p,u}$	$C_{p,u}$	$C_{p,u}$
0.050	-0.0168	-0.0047	0.1257	0.1257	0.1257	0.1257	0.1257	0.1257	0.1257	0.1257
0.100	-0.0080	-0.0025	0.1167	0.1167	0.1167	0.1167	0.1167	0.1167	0.1167	0.1167
0.150	-0.0205	-0.0028	0.1044	0.1044	0.1044	0.1044	0.1044	0.1044	0.1044	0.1044
0.200	-0.0205	0.0027	0.0919	0.0919	0.0919	0.0919	0.0919	0.0919	0.0919	0.0919
0.250	*****	-0.0047	0.0789	0.0789	0.0789	0.0789	0.0789	0.0789	0.0789	0.0789
0.300	-0.0283	-0.0045	0.0682	0.0682	0.0682	0.0682	0.0682	0.0682	0.0682	0.0682
0.350	*****	-0.0084	0.0564	0.0564	0.0564	0.0564	0.0564	0.0564	0.0564	0.0564
0.400	-0.0463	-0.0079	0.0494	0.0494	0.0494	0.0494	0.0494	0.0494	0.0494	0.0494
0.450	-0.0522	-0.0127	0.0570	0.0570	0.0570	0.0570	0.0570	0.0570	0.0570	0.0570
0.500	-0.0592	-0.0118	0.0305	0.0305	0.0305	0.0305	0.0305	0.0305	0.0305	0.0305
0.525	*****	-0.0174	0.0277	0.0277	0.0277	0.0277	0.0277	0.0277	0.0277	0.0277
0.550	-0.0644	-0.0246	0.0256	0.0256	0.0256	0.0256	0.0256	0.0256	0.0256	0.0256
0.575	*****	-0.0254	0.0275	0.0275	0.0275	0.0275	0.0275	0.0275	0.0275	0.0275
0.600	-0.0710	-0.0297	0.0118	0.0118	0.0118	0.0118	0.0118	0.0118	0.0118	0.0118
0.625	*****	*****	0.0143	0.0143	0.0143	0.0143	0.0143	0.0143	0.0143	0.0143
0.650	-0.0721	-0.0333	0.0079	0.0079	0.0079	0.0079	0.0079	0.0079	0.0079	0.0079
0.675	*****	-0.0454	0.0003	0.0003	0.0003	0.0003	0.0003	0.0003	0.0003	0.0003
0.700	-0.0696	-0.0540	-0.0045	-0.0045	-0.0045	-0.0045	-0.0045	-0.0045	-0.0045	-0.0045
0.725	*****	-0.0637	*****	*****	*****	*****	*****	*****	*****	*****
0.750	-0.0634	-0.0729	*****	*****	*****	*****	*****	*****	*****	*****
0.775	*****	-0.0787	-0.0312	-0.0312	-0.0312	-0.0312	-0.0312	-0.0312	-0.0312	-0.0312
0.800	-0.0471	-0.0852	-0.0474	-0.0474	-0.0474	-0.0474	-0.0474	-0.0474	-0.0474	-0.0474
0.825	*****	-0.0866	-0.0628	-0.0628	-0.0628	-0.0628	-0.0628	-0.0628	-0.0628	-0.0628
0.850	-0.0274	-0.0864	-0.0776	-0.0776	-0.0776	-0.0776	-0.0776	-0.0776	-0.0776	-0.0776
0.875	*****	-0.0790	-0.0863	-0.1372	-0.1372	-0.1372	-0.1372	-0.1372	-0.1372	-0.1372
0.900	0.0049	-0.0710	-0.0911	-0.0911	-0.1523	-0.1523	-0.1523	-0.1523	-0.1523	-0.1523
0.925	*****	-0.0527	-0.0833	-0.1547	-0.1547	-0.1547	-0.1547	-0.1547	-0.1547	-0.1547
0.950	0.0541	-0.0199	-0.0602	-0.1350	-0.1350	-0.1350	-0.1350	-0.1350	-0.1350	-0.1350
0.975	*****	0.0324	-0.0067	-0.0832	-0.0832	-0.0832	-0.0832	-0.0832	-0.0832	-0.0832
1.000	0.2220	0.2177	0.2054	0.1592	0.1592	0.1592	0.1592	0.1592	0.1592	0.1592
-0.200	$C_{p,l}$	$C_{p,l}$	$C_{p,l}$	$C_{p,l}$	$C_{p,l}$	$C_{p,l}$	$C_{p,l}$	$C_{p,l}$	$C_{p,l}$	$C_{p,l}$
-0.400	-0.0037	0.0192	0.0985	0.0985	0.0985	0.0985	0.0985	0.0985	0.0985	0.0985
-0.600	-0.0245	0.0187	0.0589	0.0589	0.0589	0.0589	0.0589	0.0589	0.0589	0.0589
-0.700	-0.0404	-0.0017	0.0339	0.0339	0.0339	0.0339	0.0339	0.0339	0.0339	0.0339
-0.800	-0.0370	-0.0288	0.0121	-0.0632	-0.0632	-0.0632	-0.0632	-0.0632	-0.0632	-0.0632
-0.850	-0.0167	*****	-0.0208	-0.0679	-0.0679	-0.0679	-0.0679	-0.0679	-0.0679	-0.0679
-0.900	*****	-0.0446	-0.0447	-0.0894	-0.0894	-0.0894	-0.0894	-0.0894	-0.0894	-0.0894
-0.950	*****	-0.0231	-0.0482	-0.1104	-0.1104	-0.1104	-0.1104	-0.1104	-0.1104	-0.1104
-0.975	0.0938	0.0323	-0.0007	-0.0790	-0.0790	-0.0790	-0.0790	-0.0790	-0.0790	-0.0790
-1.000	*****	0.0897	0.0548	-0.0169	-0.2091	-0.2091	-0.2091	-0.2091	-0.2091	-0.2091
	0.2056	0.2001	0.1730	0.1687	0.1687	0.1687	0.1687	0.1687	0.1687	0.1687

Medium Radius L.E.
 Run No. = 13 , Point No. = 264
 $C_N = 0.039$, $C_m = -0.0189$
 $\alpha = 0.6^\circ$, $M_\infty = 0.849$
 $R_{mac} = 48.2 \times 10^6$

Leading Edge Pressures

- starboard
- port

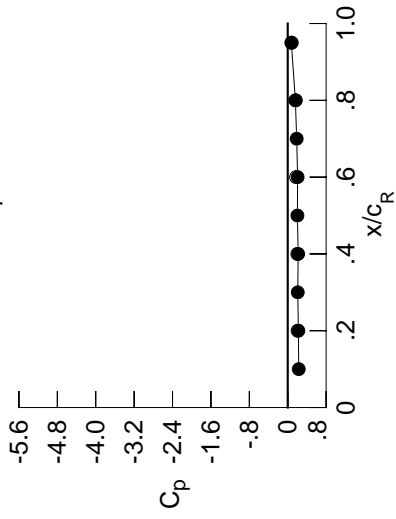

x/c_R	starb'd C_p	port C_p
0.10	0.2293	*****
0.20	0.2220	0.2056
0.30	0.2090	*****
0.40	0.2177	0.2001
0.50	0.2019	*****
0.60	0.2054	0.1730
0.70	0.1867	*****
0.80	0.1592	0.1687
0.90	0.0760	*****
0.95	0.0752	0.0844

Surface Pressures

- upper, starboard
- lower, port

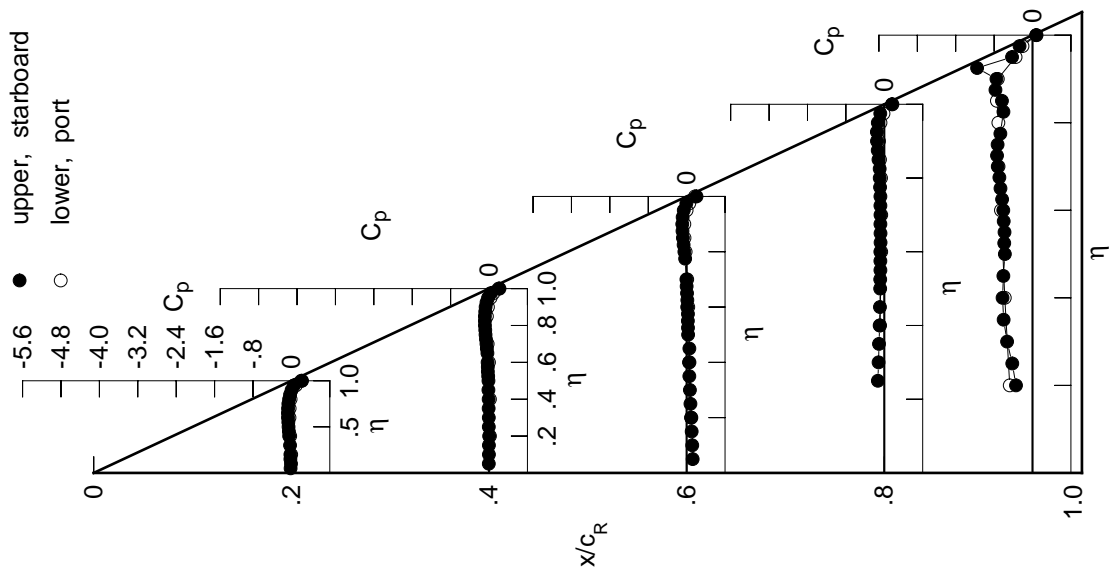
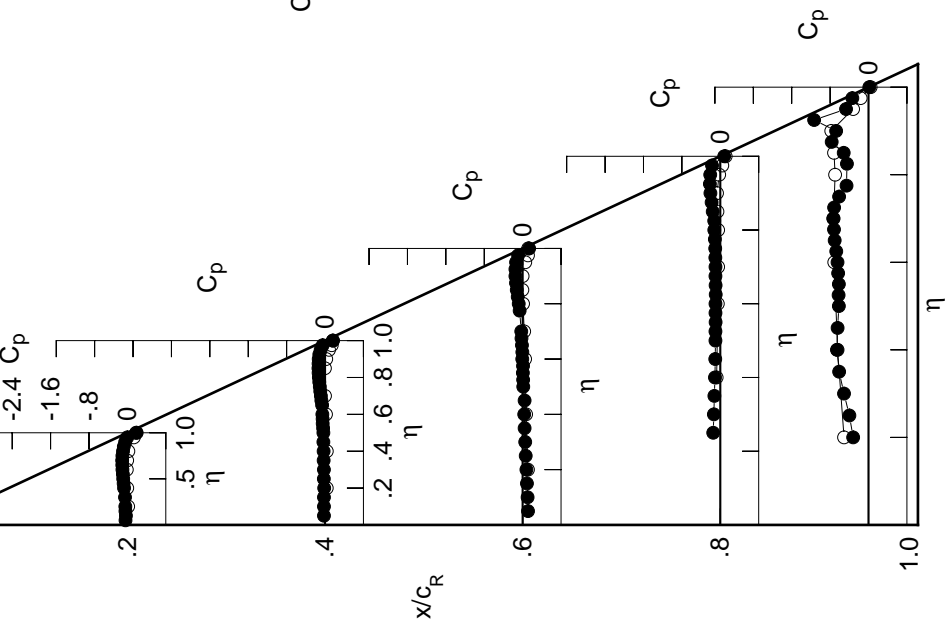
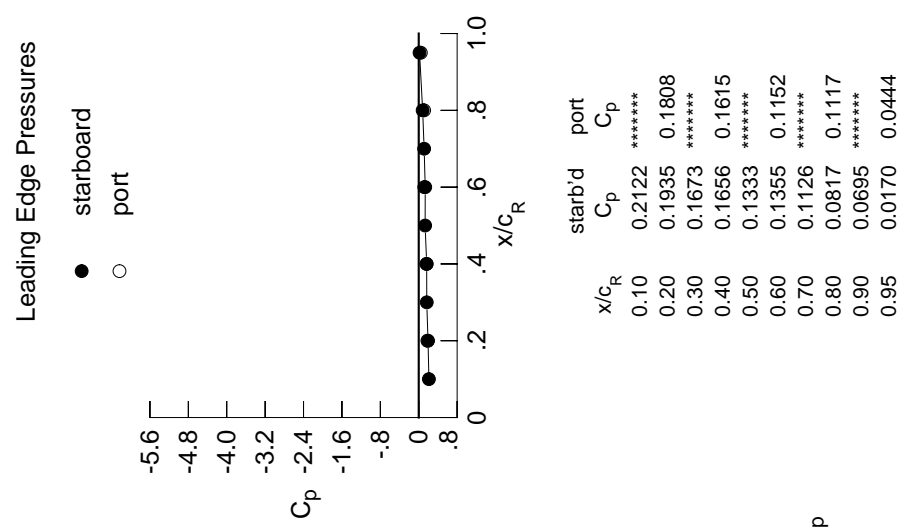

Table E5. Continued.

η	$x/c_R = .2$		$x/c_R = .4$		$x/c_R = .6$		$x/c_R = .8$		$x/c_R = .95$	
	$C_{p,u}$	$C_{p,u}$	$C_{p,u}$	$C_{p,u}$	$C_{p,u}$	$C_{p,u}$	$C_{p,u}$	$C_{p,u}$	$C_{p,u}$	$C_{p,u}$
0.050	-0.0396	-0.0226	0.1124	*****	*****	*****	*****	*****	*****	
0.100	-0.0302	-0.0220	0.1028	*****	*****	*****	*****	*****	*****	
0.150	-0.0406	-0.0223	0.0894	*****	*****	*****	*****	*****	*****	
0.200	-0.0429	-0.0179	0.0784	*****	*****	*****	*****	*****	-0.3202	
0.250	*****	-0.0248	0.0638	-0.1472	-0.1472	-0.3982	*****	*****	*****	
0.300	-0.0497	-0.0236	0.0540	-0.1339	-0.5105	*****	*****	*****	*****	
0.350	*****	-0.0289	0.0411	-0.1236	-0.6121	*****	*****	*****	*****	
0.400	-0.0698	-0.0298	0.0332	-0.1115	-0.6565	*****	*****	*****	*****	
0.450	-0.0781	-0.0340	0.0407	-0.1052	-0.6439	*****	*****	*****	*****	
0.500	-0.0872	-0.0340	0.0126	-0.1011	-0.6173	*****	*****	*****	*****	
0.525	*****	-0.0398	0.0101	-0.1009	-0.6235	*****	*****	*****	*****	
0.550	-0.0939	-0.0490	0.0051	-0.0975	-0.6173	*****	*****	*****	*****	
0.575	*****	-0.0505	0.0081	-0.1000	-0.6326	*****	*****	*****	*****	
0.600	-0.1031	-0.0563	-0.0084	-0.1002	-0.6453	*****	*****	*****	*****	
0.625	*****	*****	-0.0068	-0.0955	-0.6720	*****	*****	*****	*****	
0.650	-0.1064	-0.0605	-0.0144	-0.0976	-0.7044	*****	*****	*****	*****	
0.675	*****	-0.0771	-0.0238	-0.1012	-0.7191	*****	*****	*****	*****	
0.700	-0.1085	-0.0866	-0.0288	-0.0999	-0.7341	*****	*****	*****	*****	
0.725	*****	-0.0993	*****	-0.1033	-0.7168	*****	*****	*****	*****	
0.750	-0.1037	-0.1090	*****	-0.1054	-0.6131	*****	*****	*****	*****	
0.775	*****	-0.1201	-0.0627	-0.1132	-0.4577	*****	*****	*****	*****	
0.800	-0.0912	-0.1289	-0.0816	-0.1252	*****	*****	*****	*****	*****	
0.825	*****	-0.1344	-0.1023	-0.1261	-0.4493	*****	*****	*****	*****	
0.850	-0.0742	-0.1374	-0.1228	-0.1577	-0.5171	*****	*****	*****	*****	
0.875	*****	-0.1355	-0.1387	-0.1806	-0.7668	*****	*****	*****	*****	
0.900	-0.0465	-0.1317	-0.1506	-0.2053	-0.6746	*****	*****	*****	*****	
0.925	*****	-0.1194	-0.1506	-0.2171	-1.1331	*****	*****	*****	*****	
0.950	-0.0025	-0.0914	-0.1366	-0.2096	-0.4680	*****	*****	*****	*****	
0.975	*****	-0.0487	-0.0944	-0.1720	-0.3368	*****	*****	*****	*****	
1.000	0.1935	0.1656	0.1355	0.0817	0.0170	*****	*****	*****	*****	
-0.200	$C_{p,l}$	$C_{p,l}$	$C_{p,l}$	$C_{p,l}$	$C_{p,l}$	$C_{p,l}$	$C_{p,l}$	$C_{p,l}$	$C_{p,l}$	
-0.400	0.0161	0.0358	0.1106	*****	-0.5094	*****	*****	*****	*****	
-0.600	-0.0029	0.0369	0.0718	-0.0759	-0.6448	*****	*****	*****	*****	
-0.700	-0.0120	0.0200	0.0513	-0.0509	-0.7139	*****	*****	*****	*****	
-0.800	-0.0047	-0.0011	0.0323	-0.0447	-0.7279	*****	*****	*****	*****	
-0.850	0.0203	*****	0.0087	-0.0451	-0.6963	*****	*****	*****	*****	
-0.900	*****	-0.0023	-0.0059	-0.0591	-0.7185	*****	*****	*****	*****	
-0.950	0.1346	0.0828	0.0544	-0.0236	-0.3211	*****	*****	*****	*****	
-0.975	*****	0.1398	0.1115	0.0420	-0.1634	*****	*****	*****	*****	
-1.000	0.1808	0.1615	0.1152	0.1117	0.0444	*****	*****	*****	*****	

Medium Radius L.E.
 Run No. = 13 , Point No. = 265
 $C_N = 0.080$, $C_m = -0.0250$
 $\alpha = 1.7^\circ$, $M_\infty = 0.851$
 $R_{mac} = 48.1 \times 10^6$



x/c_R	starb'd C_p	port C_p
0.10	0.2122	*****
0.20	0.1935	0.1808
0.30	0.1673	*****
0.40	0.1656	0.1615
0.50	0.1333	*****
0.60	0.1355	0.1152
0.70	0.1126	*****
0.80	0.0817	0.1117
0.90	0.0695	*****
0.95	0.0170	0.0444

Table E5. Continued.

η	$x/c_R = .2$		$x/c_R = .4$		$x/c_R = .6$		$x/c_R = .8$		$x/c_R = .95$	
	$C_{p,u}$	$C_{p,u}$	$C_{p,u}$	$C_{p,u}$	$C_{p,u}$	$C_{p,u}$	$C_{p,u}$	$C_{p,u}$	$C_{p,u}$	$C_{p,u}$
0.050	-0.0573	-0.0394	0.1012	*****	*****	*****	*****	*****	*****	*****
0.100	-0.0480	-0.0383	0.0920	*****	*****	*****	*****	*****	*****	*****
0.150	-0.0587	-0.0385	0.0787	*****	*****	*****	*****	*****	*****	*****
0.200	-0.0613	-0.0348	0.0651	*****	*****	*****	*****	*****	*****	*****
0.250	*****	-0.0411	0.0523	-0.1597	-0.3872	*****	*****	*****	*****	*****
0.300	-0.0700	-0.0419	0.0405	-0.1456	-0.4801	*****	*****	*****	*****	*****
0.350	*****	-0.0472	0.0291	-0.1361	-0.5802	*****	*****	*****	*****	*****
0.400	-0.0929	-0.0495	0.0190	-0.1236	-0.6420	*****	*****	*****	*****	*****
0.450	-0.1028	-0.0541	0.0255	-0.1182	-0.6416	*****	*****	*****	*****	*****
0.500	-0.1122	-0.0554	-0.0030	-0.1147	-0.6197	*****	*****	*****	*****	*****
0.525	*****	-0.0613	-0.0070	-0.1149	-0.6268	*****	*****	*****	*****	*****
0.550	-0.1217	-0.0713	-0.0123	-0.1116	-0.6224	*****	*****	*****	*****	*****
0.575	*****	-0.0743	-0.0094	-0.1145	-0.6410	*****	*****	*****	*****	*****
0.600	-0.1333	-0.0798	-0.0268	-0.1159	-0.6600	*****	*****	*****	*****	*****
0.625	*****	*****	-0.0266	-0.1119	-0.6900	*****	*****	*****	*****	*****
0.650	-0.1398	-0.0877	-0.0351	-0.1145	-0.7173	*****	*****	*****	*****	*****
0.675	*****	-0.1051	-0.0453	-0.1187	-0.7181	*****	*****	*****	*****	*****
0.700	-0.1442	-0.1176	-0.0524	-0.1199	-0.6951	*****	*****	*****	*****	*****
0.725	*****	-0.1317	*****	-0.1232	-0.5985	*****	*****	*****	*****	*****
0.750	-0.1428	-0.1453	*****	-0.1296	-0.4493	*****	*****	*****	*****	*****
0.775	*****	-0.1587	-0.0930	-0.1373	-0.3217	*****	*****	*****	*****	*****
0.800	-0.1346	-0.1721	-0.1151	-0.1529	*****	*****	*****	*****	*****	*****
0.825	*****	-0.1821	-0.1417	-0.1569	-0.3465	*****	*****	*****	*****	*****
0.850	-0.1219	-0.1897	-0.1684	-0.1939	-0.3785	*****	*****	*****	*****	*****
0.875	*****	-0.1932	-0.1913	-0.2241	-0.5921	*****	*****	*****	*****	*****
0.900	-0.0989	-0.1947	-0.2115	-0.2599	-0.6238	*****	*****	*****	*****	*****
0.925	*****	-0.1905	-0.2218	-0.2830	-1.0227	*****	*****	*****	*****	*****
0.950	-0.0635	-0.1692	-0.2208	-0.2916	-0.5162	*****	*****	*****	*****	*****
0.975	*****	-0.1398	-0.1948	-0.2733	-0.4136	*****	*****	*****	*****	*****
1.000	0.1388	0.0652	0.0099	-0.0637	-0.0914	*****	*****	*****	*****	*****
	$C_{p,l}$	$C_{p,l}$	$C_{p,l}$	$C_{p,l}$	$C_{p,l}$	$C_{p,l}$	$C_{p,l}$	$C_{p,l}$	$C_{p,l}$	$C_{p,l}$
-0.200	0.0382	0.0541	0.1251	*****	*****	*****	*****	*****	*****	*****
-0.400	0.0217	0.0566	0.0877	-0.0623	-0.7089	*****	*****	*****	*****	*****
-0.600	0.0177	0.0438	0.0704	-0.0337	-0.7358	*****	*****	*****	*****	*****
-0.700	0.0280	0.0272	0.0551	-0.0268	-0.7266	*****	*****	*****	*****	*****
-0.800	0.0569	*****	0.0377	-0.0212	-0.6804	*****	*****	*****	*****	*****
-0.850	*****	0.0386	0.0297	-0.0289	-0.6972	*****	*****	*****	*****	*****
-0.900	*****	0.0688	0.0424	-0.0274	-0.7352	*****	*****	*****	*****	*****
-0.950	0.1702	0.1273	0.1025	0.0251	-0.2936	*****	*****	*****	*****	*****
-0.975	*****	0.1790	0.1553	0.0900	-0.1256	*****	*****	*****	*****	*****
-1.000	0.1280	0.0704	-0.0171	-0.0167	-0.0435	*****	*****	*****	*****	*****

Medium Radius L.E.
 Run No. = 13, Point No. = 266
 $C_N = 0.117$, $C_m = -0.0288$
 $\alpha = 2.7^\circ$, $M_\infty = 0.850$
 $R_{mac} = 47.7 \times 10^6$

Leading Edge Pressures

● starboard
 ○ port

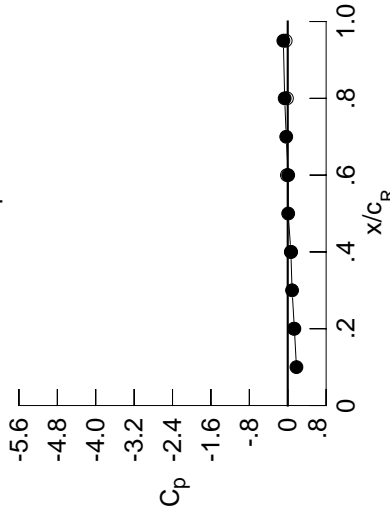

x/c_R	starb'd C_p	port C_p
0.10	0.1814	*****
0.20	0.1388	0.1280
0.30	0.0907	*****
0.40	0.0652	0.0704
0.50	0.0092	*****
0.60	0.0099	-0.0171
0.70	-0.0308	*****
0.80	-0.0637	-0.0167
0.90	0.0515	*****
0.95	-0.0914	-0.0435

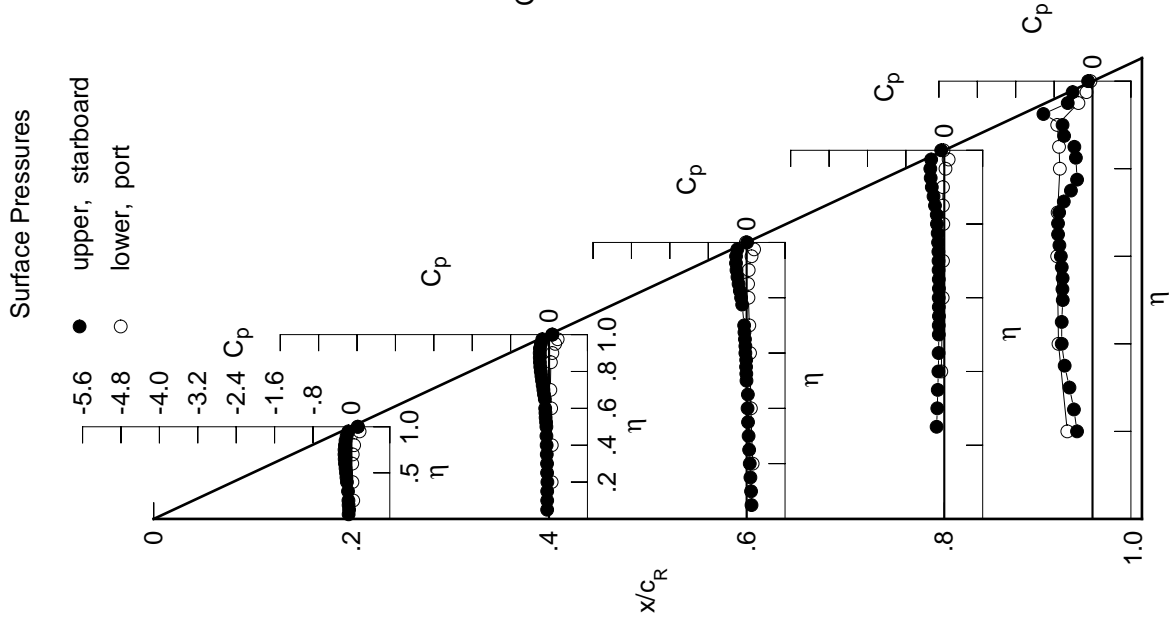

Table E5. Continued.

η	$x/c_R = .2$		$x/c_R = .4$		$x/c_R = .6$		$x/c_R = .8$		$x/c_R = .95$	
	$C_{p,u}$	$C_{p,u}$	$C_{p,u}$	$C_{p,u}$	$C_{p,u}$	$C_{p,u}$	$C_{p,u}$	$C_{p,u}$	$C_{p,u}$	$C_{p,u}$
0.050	-0.0770	-0.0573	0.0890	0.0890	0.0890	0.0890	0.0890	0.0890	0.0890	0.0890
0.100	-0.0689	-0.0561	0.0787	0.0787	0.0787	0.0787	0.0787	0.0787	0.0787	0.0787
0.150	-0.0791	-0.0565	0.0667	0.0667	0.0667	0.0667	0.0667	0.0667	0.0667	0.0667
0.200	-0.0816	-0.0516	0.0530	0.0530	0.0530	0.0530	0.0530	0.0530	0.0530	0.0530
0.250	0.0000	-0.0592	0.0372	0.0372	-0.1730	-0.1730	-0.3782	-0.3782	-0.3782	-0.3782
0.300	-0.0900	-0.0595	0.0274	-0.1583	-0.4498	-0.4498	-0.5316	-0.5316	-0.5316	-0.5316
0.350	0.0000	-0.0663	0.0143	-0.1483	-0.5316	-0.5316	-0.5994	-0.5994	-0.5994	-0.5994
0.400	-0.1149	-0.0681	0.0035	-0.1359	-0.5994	-0.5994	-0.6104	-0.6104	-0.6104	-0.6104
0.450	-0.1274	-0.0746	0.0096	-0.1323	-0.6104	-0.6104	-0.5942	-0.5942	-0.5942	-0.5942
0.500	-0.1389	-0.0772	-0.0200	-0.1281	-0.5942	-0.5942	-0.6019	-0.6019	-0.6019	-0.6019
0.525	0.0000	-0.0842	-0.0242	-0.1302	-0.6019	-0.6019	-0.5919	-0.5919	-0.5919	-0.5919
0.550	-0.1509	-0.0950	-0.0295	-0.1266	-0.5919	-0.5919	-0.5998	-0.5998	-0.5998	-0.5998
0.575	0.0000	-0.0981	-0.0283	-0.1309	-0.5998	-0.5998	-0.6015	-0.6015	-0.6015	-0.6015
0.600	-0.1649	-0.1061	-0.0456	-0.1316	-0.6015	-0.6015	-0.6181	-0.6181	-0.6181	-0.6181
0.625	0.0000	0.0000	-0.0465	-0.1302	-0.6181	-0.6181	-0.6493	-0.6493	-0.6493	-0.6493
0.650	-0.1745	-0.1161	-0.0561	-0.1324	-0.6493	-0.6493	-0.6742	-0.6742	-0.6742	-0.6742
0.675	0.0000	-0.1345	-0.0671	-0.1380	-0.6742	-0.6742	-0.7122	-0.7122	-0.7122	-0.7122
0.700	-0.1825	-0.1496	-0.0766	-0.1406	-0.7122	-0.7122	-0.7342	-0.7342	-0.7342	-0.7342
0.725	0.0000	-0.1670	0.0000	-0.1455	-0.7342	-0.7342	-0.7144	-0.7144	-0.7144	-0.7144
0.750	-0.1851	-0.1838	0.0000	-0.1533	-0.7144	-0.7144	-0.6338	-0.6338	-0.6338	-0.6338
0.775	0.0000	-0.2021	-0.1256	-0.1650	-0.6338	-0.6338	-0.5389	-0.5389	-0.5389	-0.5389
0.800	-0.1814	-0.2185	-0.1519	-0.1833	-0.5389	-0.5389	-0.4148	-0.4148	-0.4148	-0.4148
0.825	0.0000	-0.2331	-0.1827	-0.1895	-0.4148	-0.4148	-0.3790	-0.3790	-0.3790	-0.3790
0.850	-0.1743	-0.2463	-0.2157	-0.2320	-0.3790	-0.3790	-0.3936	-0.3936	-0.3936	-0.3936
0.875	0.0000	-0.2562	-0.2489	-0.2719	-0.3936	-0.3936	-0.4171	-0.4171	-0.4171	-0.4171
0.900	-0.1586	-0.2647	-0.2783	-0.3180	-0.3936	-0.3936	-0.5670	-0.5670	-0.5670	-0.5670
0.925	0.0000	-0.2684	-0.3013	-0.3549	-0.4171	-0.4171	-0.5004	-0.5004	-0.5004	-0.5004
0.950	-0.1332	-0.2567	-0.3145	-0.3827	-0.5670	-0.5670	-0.2837	-0.2837	-0.2837	-0.2837
0.975	0.0000	-0.2479	-0.3136	-0.3901	-0.5004	-0.5004	-0.2538	-0.2538	-0.2538	-0.2538
1.000	0.0536	-0.0879	-0.1602	-0.2837	-0.2538	-0.2538	0.0000	0.0000	0.0000	0.0000
	$C_{p,l}$	$C_{p,l}$	$C_{p,l}$	$C_{p,l}$	$C_{p,l}$	$C_{p,l}$	$C_{p,l}$	$C_{p,l}$	$C_{p,l}$	$C_{p,l}$
-0.200	0.0590	0.0727	0.1395	0.1395	0.1395	0.1395	-0.5586	-0.5586	-0.5586	-0.5586
-0.400	0.0452	0.0769	0.1029	-0.0479	-0.7172	-0.7172	-0.7333	-0.7333	-0.7333	-0.7333
-0.600	0.0466	0.0669	0.0871	-0.0191	-0.7333	-0.7333	-0.7168	-0.7168	-0.7168	-0.7168
-0.700	0.0596	0.0548	0.0762	-0.0084	-0.7168	-0.7168	-0.6626	-0.6626	-0.6626	-0.6626
-0.800	0.0910	0.0000	0.0656	0.0005	-0.6626	-0.6626	-0.6750	-0.6750	-0.6750	-0.6750
-0.850	0.0000	0.0752	0.0628	-0.0006	-0.6750	-0.6750	-0.6950	-0.6950	-0.6950	-0.6950
-0.900	0.0000	0.1089	0.0818	0.0083	-0.6950	-0.6950	-0.2688	-0.2688	-0.2688	-0.2688
-0.950	0.1984	0.1625	0.1411	0.0675	-0.2688	-0.2688	-0.0961	-0.0961	-0.0961	-0.0961
-0.975	0.0000	0.2051	0.1845	0.1246	-0.0961	-0.0961	-0.1852	-0.1852	-0.1852	-0.1852
-1.000	0.0411	-0.0683	-0.2230	-0.2203	-0.1852	-0.1852				

Medium Radius L.E.
 Run No. = 13 , Point No. = 267
 $C_N = 0.163$, $C_m = -0.0386$
 $\alpha = 3.8^\circ$, $M_\infty = 0.850$
 $R_{mac} = 47.6 \times 10^6$

Leading Edge Pressures

● starboard
 ○ port

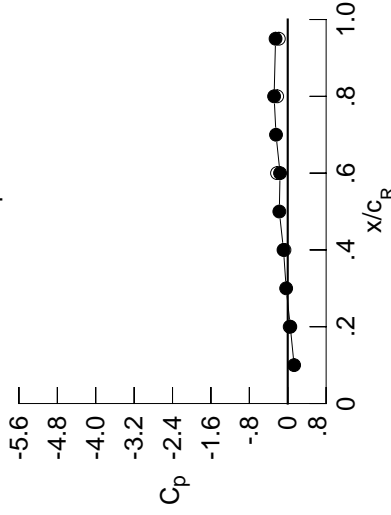

x/c_R	starb'd C_p	port C_p
0.10	0.1328	0.0411
0.20	0.0536	0.0411
0.30	-0.0325	0.0411
0.40	-0.0879	-0.0683
0.50	-0.1754	0.0411
0.60	-0.1602	-0.2230
0.70	-0.2440	0.0411
0.80	-0.2837	-0.2203
0.90	0.0258	0.0411
0.95	-0.2538	-0.1852

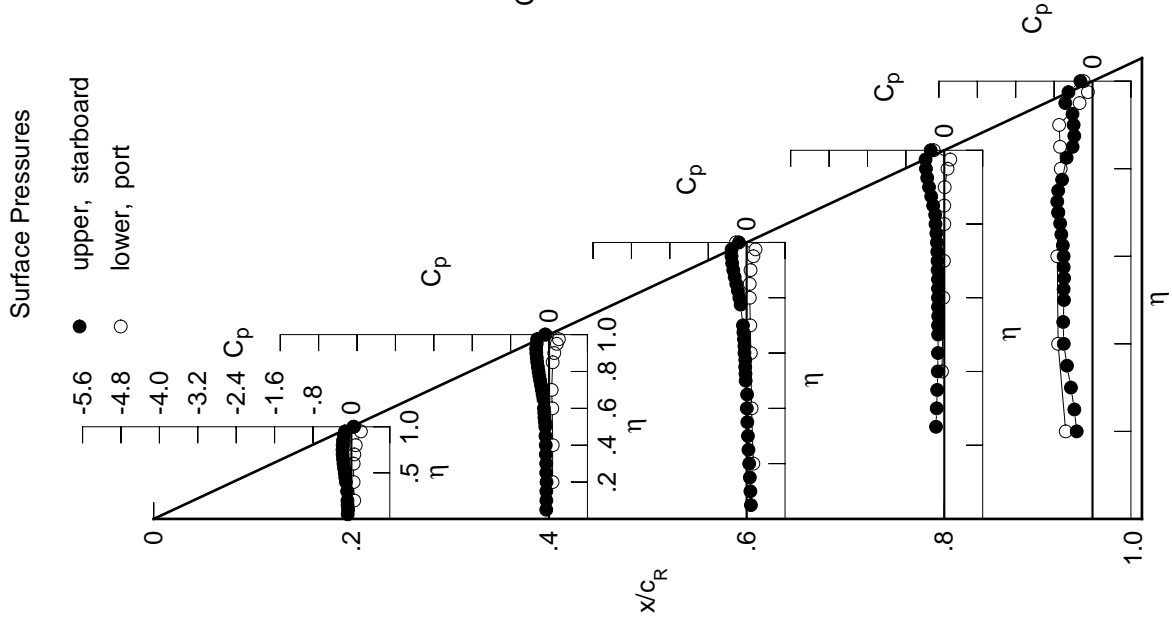

Table E5. Continued.

η	$x/c_R = .2$		$x/c_R = .4$		$x/c_R = .6$		$x/c_R = .8$		$x/c_R = .95$	
	$C_{p,u}$	$C_{p,u}$	$C_{p,u}$	$C_{p,u}$	$C_{p,u}$	$C_{p,u}$	$C_{p,u}$	$C_{p,u}$	$C_{p,u}$	$C_{p,u}$
0.050	-0.0944	-0.0721	0.0783	0.0783	0.0783	0.0783	0.0783	0.0783	0.0783	0.0783
0.100	-0.0864	-0.0712	0.0689	0.0689	0.0689	0.0689	0.0689	0.0689	0.0689	0.0689
0.150	-0.0971	-0.0727	0.0549	0.0549	0.0549	0.0549	0.0549	0.0549	0.0549	0.0549
0.200	-0.0999	-0.0687	0.0413	0.0413	0.0413	0.0413	0.0413	0.0413	0.0413	0.0413
0.250	0.0000	-0.0761	0.0268	0.0268	0.0268	0.0268	0.0268	0.0268	0.0268	0.0268
0.300	-0.1096	-0.0776	0.0147	0.0147	0.0147	0.0147	0.0147	0.0147	0.0147	0.0147
0.350	0.0000	-0.0840	0.0015	0.0015	0.0015	0.0015	0.0015	0.0015	0.0015	0.0015
0.400	-0.1377	-0.0869	-0.0103	-0.0103	-0.0103	-0.0103	-0.0103	-0.0103	-0.0103	-0.0103
0.450	-0.1509	-0.0947	-0.0048	-0.0048	-0.0048	-0.0048	-0.0048	-0.0048	-0.0048	-0.0048
0.500	-0.1642	-0.0982	-0.0357	-0.0357	-0.0357	-0.0357	-0.0357	-0.0357	-0.0357	-0.0357
0.525	0.0000	-0.1071	-0.0403	-0.0403	-0.0403	-0.0403	-0.0403	-0.0403	-0.0403	-0.0403
0.550	-0.1793	-0.1169	-0.0462	-0.0462	-0.0462	-0.0462	-0.0462	-0.0462	-0.0462	-0.0462
0.575	0.0000	-0.1226	-0.0466	-0.0466	-0.0466	-0.0466	-0.0466	-0.0466	-0.0466	-0.0466
0.600	-0.1954	-0.1310	-0.0641	-0.0641	-0.0641	-0.0641	-0.0641	-0.0641	-0.0641	-0.0641
0.625	0.0000	0.0000	-0.0667	-0.0667	-0.0667	-0.0667	-0.0667	-0.0667	-0.0667	-0.0667
0.650	-0.2098	-0.1438	-0.0772	-0.0772	-0.0772	-0.0772	-0.0772	-0.0772	-0.0772	-0.0772
0.675	0.0000	-0.1635	-0.0908	-0.0908	-0.0908	-0.0908	-0.0908	-0.0908	-0.0908	-0.0908
0.700	-0.2206	-0.1819	-0.1006	-0.1006	-0.1006	-0.1006	-0.1006	-0.1006	-0.1006	-0.1006
0.725	0.0000	-0.2013	0.0000	0.0000	-0.1675	-0.1675	-0.1675	-0.1675	-0.1675	-0.1675
0.750	-0.2277	-0.2224	0.0000	0.0000	-0.1767	-0.1767	-0.1767	-0.1767	-0.1767	-0.1767
0.775	0.0000	-0.2429	-0.1566	-0.1566	-0.1912	-0.1912	-0.1912	-0.1912	-0.1912	-0.1912
0.800	-0.2293	-0.2658	-0.1882	-0.1882	-0.2129	-0.2129	-0.2129	-0.2129	-0.2129	-0.2129
0.825	0.0000	-0.2854	-0.2249	-0.2249	-0.2212	-0.2212	-0.2212	-0.2212	-0.2212	-0.2212
0.850	-0.2287	-0.3053	-0.2659	-0.2659	-0.2703	-0.2703	-0.2703	-0.2703	-0.2703	-0.2703
0.875	0.0000	-0.3226	-0.3069	-0.3069	-0.3184	-0.3184	-0.3184	-0.3184	-0.3184	-0.3184
0.900	-0.2208	-0.3384	-0.3493	-0.3493	-0.3769	-0.3769	-0.3769	-0.3769	-0.3769	-0.3769
0.925	0.0000	-0.3530	-0.3870	-0.3870	-0.4323	-0.4323	-0.4323	-0.4323	-0.4323	-0.4323
0.950	-0.2094	-0.3553	-0.4200	-0.4200	-0.4803	-0.4803	-0.4803	-0.4803	-0.4803	-0.4803
0.975	0.0000	-0.3703	-0.4443	-0.4443	-0.5270	-0.5270	-0.5270	-0.5270	-0.5270	-0.5270
1.000	-0.0619	-0.2820	-0.3884	-0.3884	-0.5836	-0.5836	-0.5836	-0.5836	-0.5836	-0.5836
-0.200	0.0817	0.0934	0.1540	0.1540	0.1540	0.1540	0.1540	0.1540	0.1540	0.1540
-0.400	0.0704	0.0966	0.1204	0.1204	0.0343	0.0343	0.0343	0.0343	0.0343	0.0343
-0.600	0.0758	0.0911	0.1065	0.1065	0.0012	0.0012	0.0012	0.0012	0.0012	0.0012
-0.700	0.0919	0.0826	0.0991	0.0991	0.0097	0.0097	0.0097	0.0097	0.0097	0.0097
-0.800	0.1245	0.0000	0.0929	0.0929	0.0241	0.0241	0.0241	0.0241	0.0241	0.0241
-0.850	0.0000	0.1112	0.0948	0.0948	0.0260	0.0260	0.0260	0.0260	0.0260	0.0260
-0.900	0.0000	0.1446	0.1171	0.1171	0.0423	0.0423	0.0423	0.0423	0.0423	0.0423
-0.950	0.2205	0.1917	0.1728	0.1728	0.1015	0.1015	0.1015	0.1015	0.1015	0.1015
-0.975	0.0000	0.2192	0.2027	0.2027	0.1477	0.1477	0.1477	0.1477	0.1477	0.1477
-1.000	-0.0695	-0.2484	-0.5003	-0.5003	-0.4991	-0.4991	-0.4991	-0.4991	-0.4991	-0.4991

Medium Radius L.E.
 Run No. = 13, Point No. = 268
 $C_N = 0.205$, $C_m = -0.0442$
 $\alpha = 4.9^\circ$, $M_\infty = 0.851$
 $R_{mac} = 47.7 \times 10^6$

Leading Edge Pressures

- starboard
- port

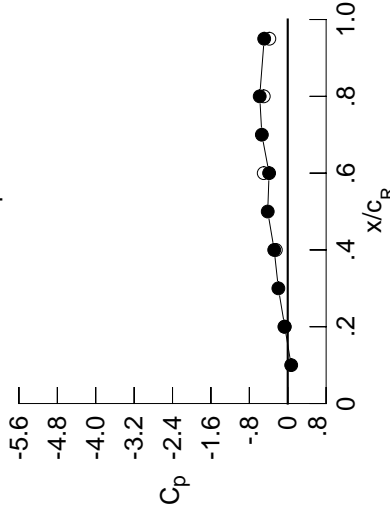

x/c_R	starb'd C_p	port C_p
0.10	0.0716	0.0716
0.20	-0.0619	-0.0695
0.30	-0.1951	0.0000
0.40	-0.2820	-0.2484
0.50	-0.4169	0.0000
0.60	-0.3884	-0.5003
0.70	-0.5390	0.0000
0.80	-0.5836	-0.4991
0.90	-0.0049	0.0000
0.95	-0.4905	-0.3832

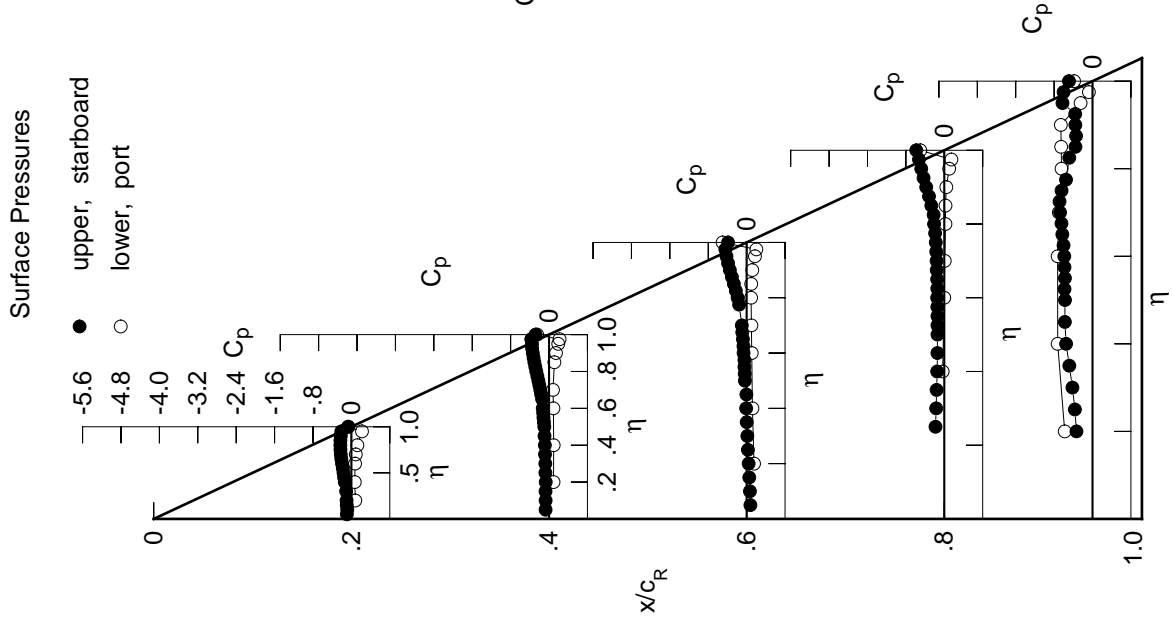
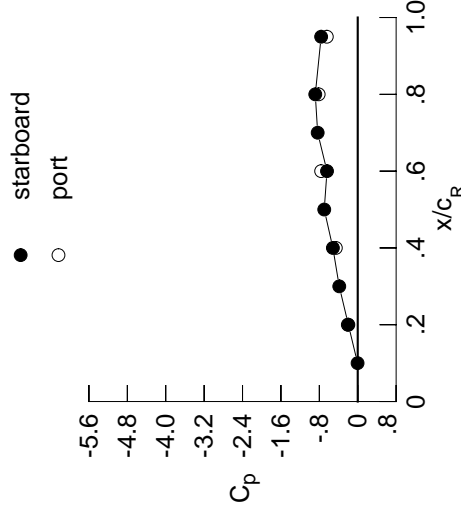

Table E5. Continued.

η	$x/c_R = .2$		$x/c_R = .4$		$x/c_R = .6$		$x/c_R = .8$		$x/c_R = .95$	
	$C_{p,u}$	$C_{p,u}$	$C_{p,u}$	$C_{p,u}$	$C_{p,u}$	$C_{p,u}$	$C_{p,u}$	$C_{p,u}$	$C_{p,u}$	$C_{p,u}$
0.050	-0.1110	-0.0896	0.0663	0.0663	0.0663	0.0663	0.0663	0.0663	0.0663	0.0663
0.100	-0.1048	-0.0874	0.0574	0.0574	0.0574	0.0574	0.0574	0.0574	0.0574	0.0574
0.150	-0.1160	-0.0906	0.0429	0.0429	0.0429	0.0429	0.0429	0.0429	0.0429	0.0429
0.200	-0.1187	-0.0858	0.0295	0.0295	0.0295	0.0295	0.0295	0.0295	0.0295	0.0295
0.250	0.0000	-0.0934	0.0139	0.0139	0.0139	0.0139	0.0139	0.0139	0.0139	0.0139
0.300	-0.1287	-0.0965	0.0024	0.0024	-0.1811	-0.3976	-0.1811	-0.3976	-0.1811	-0.3976
0.350	0.0000	-0.1025	-0.0119	-0.1738	-0.4463	-0.4463	-0.4463	-0.4463	-0.4463	-0.4463
0.400	-0.1586	-0.1073	-0.0235	-0.1608	-0.5112	-0.5112	-0.5112	-0.5112	-0.5112	-0.5112
0.450	-0.1749	-0.1149	-0.0204	-0.1581	-0.5488	-0.5488	-0.5488	-0.5488	-0.5488	-0.5488
0.500	-0.1907	-0.1212	-0.0509	-0.1565	-0.5645	-0.5645	-0.5645	-0.5645	-0.5645	-0.5645
0.525	0.0000	-0.1294	-0.0580	-0.1585	-0.5864	-0.5864	-0.5864	-0.5864	-0.5864	-0.5864
0.550	-0.2077	-0.1414	-0.0639	-0.1573	-0.5805	-0.5805	-0.5805	-0.5805	-0.5805	-0.5805
0.575	0.0000	-0.1470	-0.0649	-0.1614	-0.5929	-0.5929	-0.5929	-0.5929	-0.5929	-0.5929
0.600	-0.2282	-0.1582	-0.0844	-0.1648	-0.5983	-0.5983	-0.5983	-0.5983	-0.5983	-0.5983
0.625	0.0000	0.0000	-0.0868	-0.1636	-0.6306	-0.6306	-0.6306	-0.6306	-0.6306	-0.6306
0.650	-0.2450	-0.1723	-0.0990	-0.1687	-0.6612	-0.6612	-0.6612	-0.6612	-0.6612	-0.6612
0.675	0.0000	-0.1940	-0.1135	-0.1789	-0.6630	-0.6630	-0.6630	-0.6630	-0.6630	-0.6630
0.700	-0.2606	-0.2143	-0.1271	-0.1825	-0.6774	-0.6774	-0.6774	-0.6774	-0.6774	-0.6774
0.725	0.0000	-0.2364	0.0000	-0.1918	-0.6580	-0.6580	-0.6580	-0.6580	-0.6580	-0.6580
0.750	-0.2723	-0.2610	0.0000	-0.2031	-0.5805	-0.5805	-0.5805	-0.5805	-0.5805	-0.5805
0.775	0.0000	-0.2867	-0.1913	-0.2227	-0.4964	-0.4964	-0.4964	-0.4964	-0.4964	-0.4964
0.800	-0.2798	-0.3140	-0.2251	-0.2473	0.0000	0.0000	0.0000	0.0000	0.0000	0.0000
0.825	0.0000	-0.3404	-0.2678	-0.2597	-0.4393	-0.4393	-0.4393	-0.4393	-0.4393	-0.4393
0.850	-0.2852	-0.3657	-0.3146	-0.3111	-0.3246	-0.3246	-0.3246	-0.3246	-0.3246	-0.3246
0.875	0.0000	-0.3903	-0.3671	-0.3656	-0.3221	-0.3221	-0.3221	-0.3221	-0.3221	-0.3221
0.900	-0.2871	-0.4157	-0.4238	-0.4362	-0.3328	-0.3328	-0.3328	-0.3328	-0.3328	-0.3328
0.925	0.0000	-0.4414	-0.4772	-0.5059	-0.3262	-0.3262	-0.3262	-0.3262	-0.3262	-0.3262
0.950	-0.2922	-0.4577	-0.5319	-0.5758	-0.6811	-0.6811	-0.6811	-0.6811	-0.6811	-0.6811
0.975	0.0000	-0.5078	-0.5951	-0.6649	-0.7116	-0.7116	-0.7116	-0.7116	-0.7116	-0.7116
1.000	-0.1952	-0.5176	-0.6403	-0.8844	-0.7625	-0.7625	-0.7625	-0.7625	-0.7625	-0.7625
-0.200	$C_{p,l}$	0.1036	0.1118	0.1682	0.1682	0.1682	0.1682	0.1682	0.1682	0.1682
-0.400	$C_{p,l}$	0.0936	0.1162	0.1356	0.1356	0.1356	0.1356	0.1356	0.1356	0.1356
-0.600	$C_{p,l}$	0.1025	0.1134	0.1242	0.1242	0.1242	0.1242	0.1242	0.1242	0.1242
-0.700	$C_{p,l}$	0.1203	0.1075	0.1189	0.1189	0.1189	0.1189	0.1189	0.1189	0.1189
-0.800	$C_{p,l}$	0.1542	0.0000	0.1169	0.0438	-0.6303	-0.6303	-0.6303	-0.6303	-0.6303
-0.850	$C_{p,l}$	0.0000	0.1413	0.1218	0.0488	-0.6349	-0.6349	-0.6349	-0.6349	-0.6349
-0.900	$C_{p,l}$	0.0000	0.1739	0.1459	0.0699	-0.6313	-0.6313	-0.6313	-0.6313	-0.6313
-0.950	$C_{p,l}$	0.2359	0.2116	0.1950	0.1267	-0.2326	-0.2326	-0.2326	-0.2326	-0.2326
-0.975	$C_{p,l}$	0.0000	0.2220	0.2091	0.1594	-0.0635	-0.0635	-0.0635	-0.0635	-0.0635
-1.000	$C_{p,l}$	-0.2061	-0.4560	-0.7624	-0.8135	-0.6437	-0.6437	-0.6437	-0.6437	-0.6437

Medium Radius L.E.
 Run No. = 13, Point No. = 269
 $C_N = 0.247$, $C_m = -0.0511$
 $\alpha = 5.9^\circ$, $M_\infty = 0.851$
 $R_{mac} = 48.1 \times 10^6$

Leading Edge Pressures



x/c_R	starb'd C_p	port C_p
0.10	-0.0033	0.0000
0.20	-0.1952	-0.2061
0.30	-0.3850	0.0000
0.40	-0.5176	-0.4560
0.50	-0.6977	0.0000
0.60	-0.6403	-0.7624
0.70	-0.8347	0.0000
0.80	-0.8844	-0.8135
0.90	-0.0523	0.0000
0.95	-0.7625	-0.6437

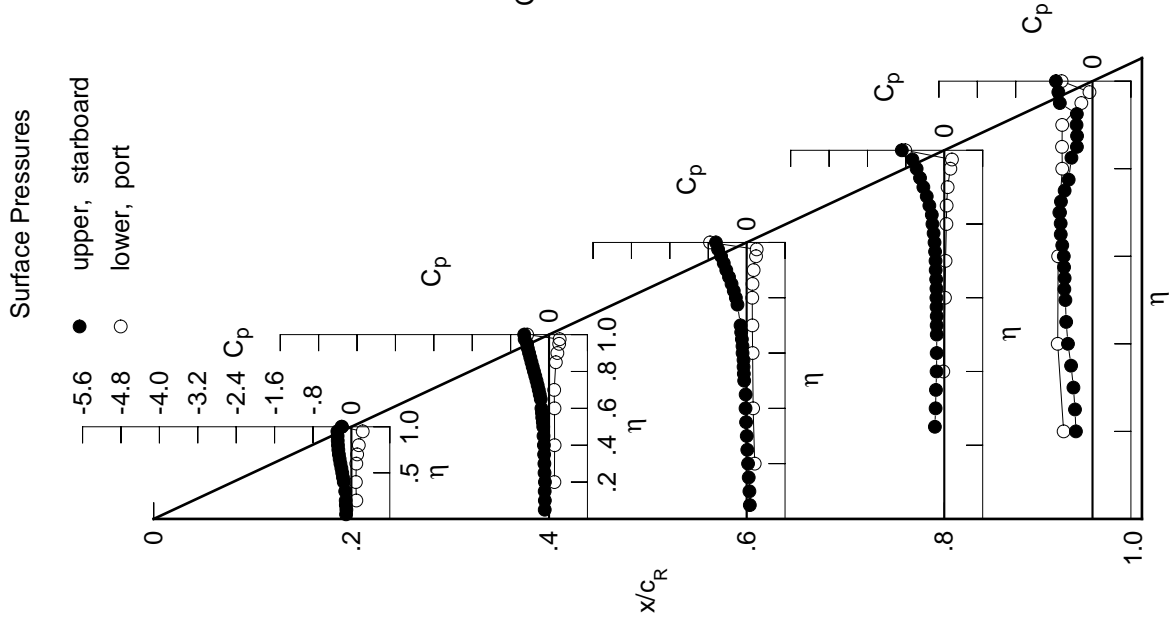

Table E5. Continued.

η	$x/c_R = .2$		$x/c_R = .4$		$x/c_R = .6$		$x/c_R = .8$		$x/c_R = .95$	
	$C_{p,u}$	$C_{p,l}$	$C_{p,u}$	$C_{p,l}$	$C_{p,u}$	$C_{p,l}$	$C_{p,u}$	$C_{p,l}$	$C_{p,u}$	$C_{p,l}$
0.050	-0.1296	-0.1051	0.0546	*****	*****	*****	*****	*****	*****	*****
0.100	-0.1234	-0.1047	0.0447	*****	*****	*****	*****	*****	*****	*****
0.150	-0.1345	-0.1073	0.0309	*****	*****	*****	*****	*****	*****	*****
0.200	-0.1383	-0.1028	0.0170	*****	*****	*****	*****	*****	*****	*****
0.250	*****	-0.1111	0.0012	-0.2080	-0.1941	-0.1855	-0.4063	-0.4647	-0.5184	-0.6037
0.300	-0.1488	-0.1141	-0.0109	-0.1941	-0.1855	-0.4063	-0.4647	-0.5184	-0.6037	-0.6705
0.350	*****	-0.1223	-0.0253	-0.1855	-0.4063	-0.4647	-0.5184	-0.6037	-0.6705	-0.6974
0.400	-0.1812	-0.1263	-0.0395	-0.1744	-0.4647	-0.5184	-0.6037	-0.6705	-0.6974	-0.7151
0.450	-0.1988	-0.1366	-0.0354	-0.1721	-0.5184	-0.6037	-0.6705	-0.6974	-0.7151	-0.6896
0.500	-0.2165	-0.1434	-0.0684	-0.1709	-0.6037	-0.6705	-0.6974	-0.7151	-0.6896	-0.6395
0.525	*****	-0.1537	-0.0748	-0.1727	-0.6705	-0.6974	-0.7151	-0.6896	-0.6395	-0.5692
0.550	-0.2368	-0.1659	-0.0820	-0.1718	-0.6974	-0.7151	-0.6896	-0.6395	-0.5692	-0.4988
0.575	*****	-0.1743	-0.0844	-0.1757	-0.7151	-0.6896	-0.6395	-0.5692	-0.4988	-0.4375
0.600	-0.2591	-0.1851	-0.1046	-0.1805	-0.6896	-0.6395	-0.5692	-0.4988	-0.4375	-0.3684
0.625	*****	*****	-0.1101	-0.1814	-0.6395	-0.5692	-0.4988	-0.4375	-0.3684	-0.2789
0.650	-0.2807	-0.2020	-0.1218	-0.1921	-0.5692	-0.4988	-0.4375	-0.3684	-0.2789	-0.2035
0.675	*****	-0.2258	-0.1394	-0.2056	-0.4988	-0.4375	-0.3684	-0.2789	-0.2035	-0.2904
0.700	-0.3010	-0.2486	-0.1563	-0.2172	-0.4375	-0.3684	-0.2789	-0.2035	-0.2904	-0.2153
0.725	*****	-0.2734	*****	-0.2326	-0.3684	-0.2789	-0.2035	-0.2904	-0.2153	-0.2302
0.750	-0.3177	-0.3017	*****	-0.2507	-0.2789	-0.2035	-0.2904	-0.2153	-0.2302	-0.2743
0.775	*****	-0.3319	-0.2307	-0.2666	-0.2035	-0.2904	-0.2153	-0.2302	-0.2743	-0.4906
0.800	-0.3321	-0.3644	-0.2663	-0.2904	-0.2153	-0.2302	-0.2743	-0.4906	-0.5649	-0.7503
0.825	*****	-0.3964	-0.3092	-0.3013	-0.2153	-0.2302	-0.2743	-0.4906	-0.5649	-0.8164
0.850	-0.3461	-0.4299	-0.3625	-0.3426	-0.2302	-0.2743	-0.4906	-0.5649	-0.8164	-0.9823
0.875	*****	-0.4631	-0.4210	-0.3990	-0.2743	-0.4906	-0.5649	-0.8164	-0.9823	-0.6077
0.900	-0.3595	-0.4994	-0.4882	-0.4805	-0.4906	-0.5649	-0.8164	-0.9823	-0.6077	-0.7246
0.925	*****	-0.5419	-0.5561	-0.5695	-0.5649	-0.8164	-0.9823	-0.6077	-0.7246	-0.7068
0.950	-0.3829	-0.5729	-0.6304	-0.6698	-0.7503	-0.8164	-0.9823	-0.6077	-0.7246	-0.6805
0.975	*****	-0.6580	-0.7102	-0.7516	-0.8164	-0.9823	-0.6077	-0.7246	-0.6805	-0.6168
1.000	-0.3560	-0.7823	-0.8206	-1.1163	-0.9823	-0.6077	-0.7246	-0.6805	-0.6168	-0.6187
	$C_{p,l}$	$C_{p,l}$	$C_{p,l}$	$C_{p,l}$	$C_{p,l}$	$C_{p,l}$	$C_{p,l}$	$C_{p,l}$	$C_{p,l}$	$C_{p,l}$
-0.200	0.1247	0.1306	0.1824	*****	-0.6077	-0.7246	-0.6805	-0.6168	-0.6187	-0.6081
-0.400	0.1175	0.1362	0.1500	-0.0063	-0.7246	-0.6805	-0.6168	-0.6187	-0.6081	-0.2232
-0.600	0.1294	0.1343	0.1414	0.0284	-0.7068	-0.6805	-0.6168	-0.6187	-0.6081	-0.0636
-0.700	0.1488	0.1324	0.1381	0.0421	-0.6805	-0.6168	-0.6187	-0.6081	-0.2232	-0.6081
-0.800	0.1814	*****	0.1394	0.0628	-0.6168	-0.6187	-0.6081	-0.2232	-0.6081	-0.6081
-0.850	*****	0.1694	0.1472	0.0707	-0.6187	-0.6081	-0.2232	-0.6081	-0.6081	-0.6081
-0.900	*****	0.1998	0.1716	0.0943	-0.6081	-0.6081	-0.2232	-0.6081	-0.6081	-0.6081
-0.950	0.2454	0.2259	0.2104	0.1441	-0.2232	-0.6081	-0.6081	-0.6081	-0.6081	-0.6081
-0.975	*****	0.2157	0.2061	0.1614	-0.0636	-0.6081	-0.6081	-0.6081	-0.6081	-0.6081
-1.000	-0.3724	-0.6821	-0.9742	-1.0207	-0.8585	-0.8585	-0.8585	-0.8585	-0.8585	-0.8585

Medium Radius L.E.
 Run No. = 13, Point No. = 270
 $C_N = 0.290$, $C_m = -0.0583$
 $\alpha = 6.9^\circ$, $M_\infty = 0.851$
 $R_{mac} = 48.4 \times 10^6$

Leading Edge Pressures

● starboard
 ○ port

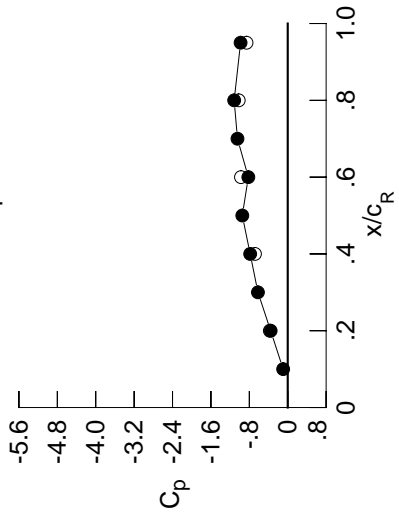

x/c_R	starb'd C_p	port C_p
0.10	-0.0953	*****
0.20	-0.3560	-0.3724
0.30	-0.6205	*****
0.40	-0.7823	-0.6821
0.50	-0.9468	*****
0.60	-0.8206	-0.9742
0.70	-1.0470	*****
0.80	-1.1163	-1.0207
0.90	-0.0969	*****
0.95	-0.9823	-0.8585

Surface Pressures

● upper, starboard
 ○ lower, port

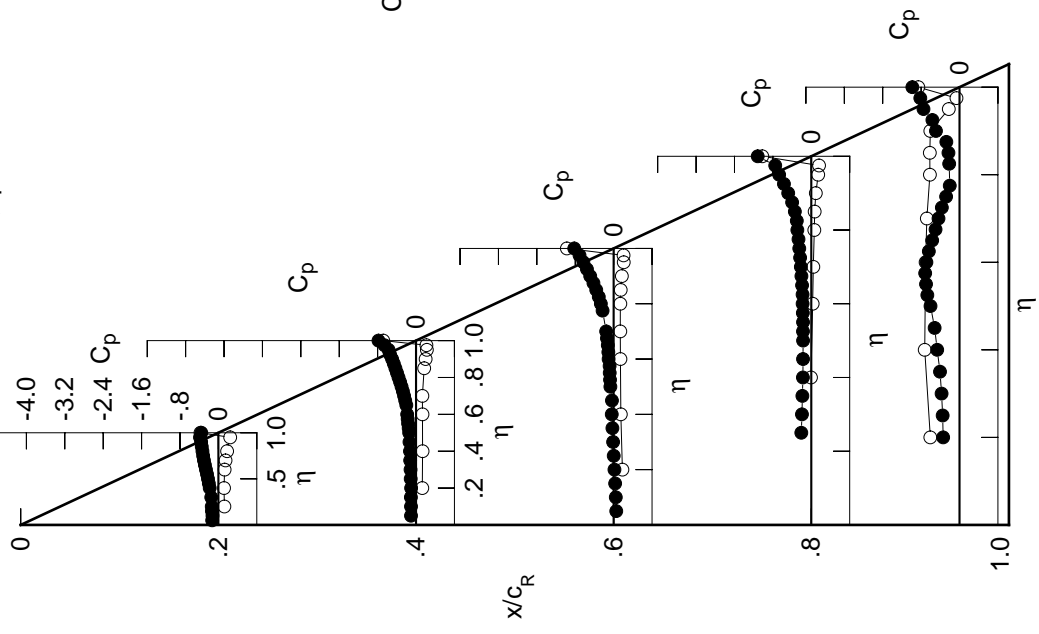

Table E5. Continued.

η	x/c_R .2	x/c_R .4	x/c_R .6	x/c_R .8	x/c_R .95
	$C_{p,u}$	$C_{p,u}$	$C_{p,u}$	$C_{p,u}$	$C_{p,u}$
0.050	-0.1457	-0.1222	0.0412	*****	*****
0.100	-0.1424	-0.1217	0.0310	*****	*****
0.150	-0.1533	-0.1239	0.0174	*****	*****
0.200	-0.1573	-0.1215	0.0026	*****	-0.3384
0.250	*****	-0.1296	-0.0131	-0.2247	-0.3353
0.300	-0.1689	-0.1336	-0.0253	-0.2105	-0.3425
0.350	*****	-0.1418	-0.0406	-0.2026	-0.3629
0.400	-0.2044	-0.1466	-0.0555	-0.1909	-0.4576
0.450	-0.2236	-0.1581	-0.0524	-0.1868	-0.6432
0.500	-0.2432	-0.1669	-0.0858	-0.1869	-0.7201
0.525	*****	-0.1787	-0.0934	-0.1920	-0.7400
0.550	-0.2659	-0.1924	-0.1031	-0.1956	-0.7251
0.575	*****	-0.2014	-0.1081	-0.2038	-0.7141
0.600	-0.2913	-0.2150	-0.1356	-0.2148	-0.6706
0.625	*****	*****	-0.1449	-0.2222	-0.6170
0.650	-0.3169	-0.2368	-0.1644	-0.2337	-0.5711
0.675	*****	-0.2606	-0.1831	-0.2465	-0.5408
0.700	-0.3418	-0.2835	-0.2012	-0.2645	-0.5345
0.725	*****	-0.3110	*****	-0.2824	-0.5306
0.750	-0.3657	-0.3407	*****	-0.2896	-0.5030
0.775	*****	-0.3757	-0.2657	-0.2890	-0.5119
0.800	-0.3867	-0.4114	-0.2980	-0.3093	*****
0.825	*****	-0.4509	-0.3423	-0.3728	-0.5623
0.850	-0.4083	-0.4905	-0.3967	-0.4416	-0.5263
0.875	*****	-0.5354	-0.4620	-0.4332	-0.5946
0.900	-0.4325	-0.5817	-0.5369	-0.4640	-0.6650
0.925	*****	-0.6373	-0.6232	-0.6397	-0.8083
0.950	-0.4854	-0.6813	-0.7758	-0.8880	-0.6378
0.975	*****	-0.7683	-1.1052	-0.9164	-0.7319
1.000	-0.5493	-0.9981	-0.9315	-1.2345	-1.0560
	$C_{p,l}$	$C_{p,l}$	$C_{p,l}$	$C_{p,l}$	$C_{p,l}$
-0.200	0.1485	0.1508	0.1986	*****	-0.6129
-0.400	0.1422	0.1571	0.1677	0.0095	-0.7142
-0.600	0.1567	0.1569	0.1598	0.0440	-0.6947
-0.700	0.1764	0.1577	0.1579	0.0587	-0.6679
-0.800	0.2083	*****	0.1627	0.0808	-0.6002
-0.850	*****	0.1965	0.1712	0.0913	-0.6014
-0.900	*****	0.2231	0.1946	0.1160	-0.5818
-0.950	0.2503	0.2360	0.2227	0.1596	-0.2070
-0.975	*****	0.2043	0.1995	0.1624	-0.0509
-1.000	-0.5709	-0.8841	-1.1336	-1.1437	-0.8855

Medium Radius L.E.
 Run No. = 13, Point No. = 271
 $C_N = 0.343$, $C_m = -0.0704$
 $\alpha = 8.0^\circ$, $M_\infty = 0.850$
 $R_{mac} = 48.5 \times 10^6$

Leading Edge Pressures

● starboard
 ○ port

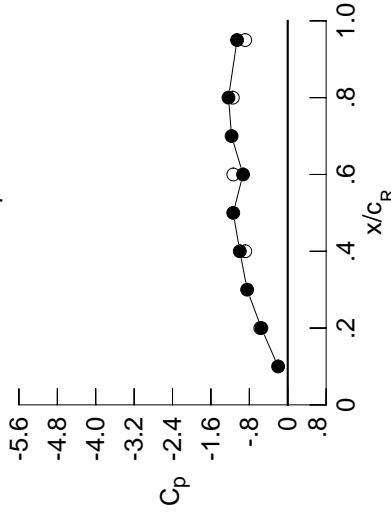

x/c_R	starb'd C_p	port C_p
0.10	-0.2001	*****
0.20	-0.5493	-0.5709
0.30	-0.8452	*****
0.40	-0.9981	-0.8841
0.50	-1.1352	*****
0.60	-0.9315	-1.1336
0.70	-1.1693	*****
0.80	-1.2345	-1.1437
0.90	-1.209	*****
0.95	-1.0560	-0.8855

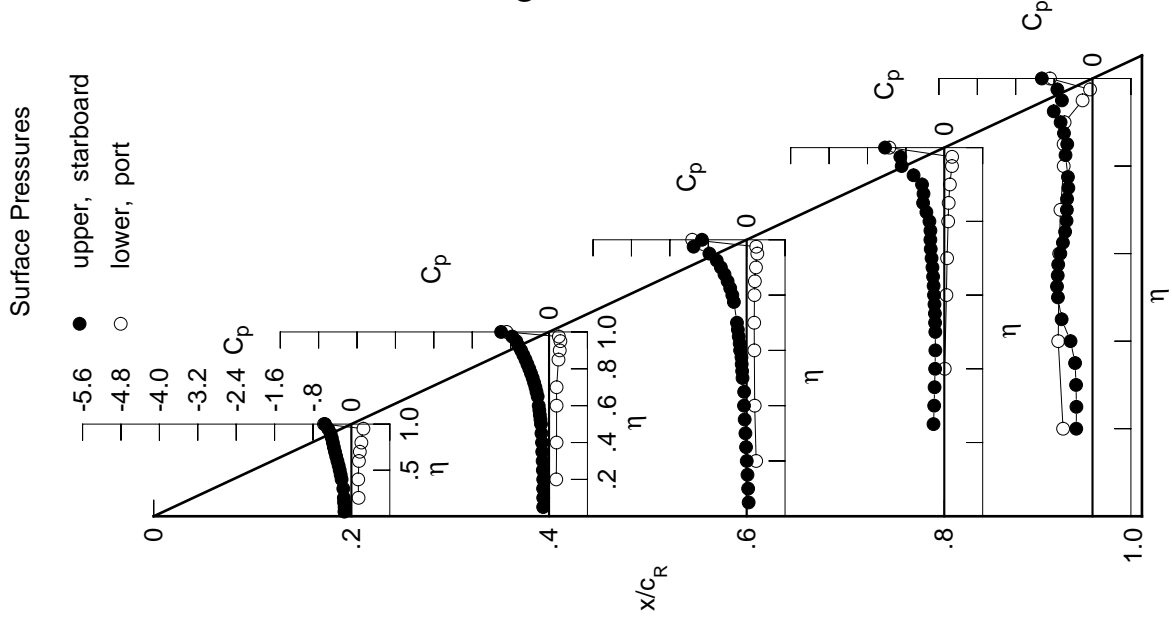

Table E5. Continued.

η	$x/c_R = .2$		$x/c_R = .4$		$x/c_R = .6$		$x/c_R = .8$		$x/c_R = .95$	
	$C_{p,u}$	$C_{p,u}$	$C_{p,u}$	$C_{p,u}$	$C_{p,u}$	$C_{p,u}$	$C_{p,u}$	$C_{p,u}$	$C_{p,u}$	$C_{p,u}$
0.050	-0.1609	-0.1391	0.0257	*****	*****	*****	*****	*****	*****	
0.100	-0.1593	-0.1405	0.0161	*****	*****	*****	*****	*****	*****	
0.150	-0.1719	-0.1429	0.0012	*****	*****	*****	*****	*****	*****	
0.200	-0.1761	-0.1406	-0.0129	*****	*****	*****	*****	*****	-0.3345	
0.250	*****	-0.1483	-0.0307	-0.2465	-0.2807	*****	*****	*****	*****	
0.300	-0.1892	-0.1535	-0.0418	-0.2319	-0.2659	*****	*****	*****	*****	
0.350	*****	-0.1620	-0.0583	-0.2214	-0.3548	*****	*****	*****	*****	
0.400	-0.2260	-0.1687	-0.0708	-0.2089	-0.5369	*****	*****	*****	*****	
0.450	-0.2473	-0.1805	-0.0703	-0.2115	-0.6624	*****	*****	*****	*****	
0.500	-0.2682	-0.1934	-0.1149	-0.2171	-0.6263	*****	*****	*****	*****	
0.525	*****	-0.2077	-0.1312	-0.2261	-0.6008	*****	*****	*****	*****	
0.550	-0.2944	-0.2258	-0.1459	-0.2358	-0.5463	*****	*****	*****	*****	
0.575	*****	-0.2377	-0.1545	-0.2519	-0.5249	*****	*****	*****	*****	
0.600	-0.3226	-0.2551	-0.1829	-0.2597	-0.4926	*****	*****	*****	*****	
0.625	*****	*****	-0.1904	-0.2600	-0.4757	*****	*****	*****	*****	
0.650	-0.3526	-0.2761	-0.2081	-0.2743	-0.4585	*****	*****	*****	*****	
0.675	*****	-0.2987	-0.2224	-0.3009	-0.4490	*****	*****	*****	*****	
0.700	-0.3833	-0.3202	-0.2294	-0.3125	-0.4658	*****	*****	*****	*****	
0.725	*****	-0.3460	*****	-0.3162	-0.5012	*****	*****	*****	*****	
0.750	-0.4146	-0.3764	*****	-0.3185	-0.5016	*****	*****	*****	*****	
0.775	*****	-0.4131	-0.3321	-0.3305	-0.4957	*****	*****	*****	*****	
0.800	-0.4438	-0.4538	-0.3628	-0.3773	*****	*****	*****	*****	*****	
0.825	*****	-0.4988	-0.3907	-0.4917	-0.5206	*****	*****	*****	*****	
0.850	-0.4760	-0.5448	-0.4089	-0.6030	-0.4788	*****	*****	*****	*****	
0.875	*****	-0.5964	-0.4719	-0.5116	-0.5166	*****	*****	*****	*****	
0.900	-0.5150	-0.6510	-0.7577	-0.4803	-0.7149	*****	*****	*****	*****	
0.925	*****	-0.7117	-0.7973	-0.7322	-0.8314	*****	*****	*****	*****	
0.950	-0.5924	-0.7652	-0.7266	-1.0315	-0.6613	*****	*****	*****	*****	
0.975	*****	-1.1917	-1.3496	-0.9041	-0.8523	*****	*****	*****	*****	
1.000	-0.7414	-1.1492	-1.0063	-1.3119	-1.1812	*****	*****	*****	*****	
-0.200	$C_{p,l}$	$C_{p,l}$	$C_{p,l}$	$C_{p,l}$	$C_{p,l}$	$C_{p,l}$	$C_{p,l}$	$C_{p,l}$	$C_{p,l}$	
-0.400	0.1736	0.1730	0.2137	*****	*****	-0.6132	*****	*****	*****	
-0.600	0.1684	0.1802	0.1860	0.0243	-0.7048	*****	*****	*****	*****	
-0.700	0.1848	0.1819	0.1789	0.0596	-0.6826	*****	*****	*****	*****	
-0.800	0.2044	0.1835	0.1782	0.0761	-0.6545	*****	*****	*****	*****	
-0.850	0.2340	*****	0.1845	0.0982	-0.5851	*****	*****	*****	*****	
-0.900	*****	0.2223	0.1941	0.1103	-0.5856	*****	*****	*****	*****	
-0.950	*****	0.2441	0.2145	0.1353	-0.5615	*****	*****	*****	*****	
-0.975	0.2517	0.2436	0.2304	0.1713	-0.2045	*****	*****	*****	*****	
-1.000	*****	0.1906	0.1906	0.1603	-0.0637	*****	*****	*****	*****	
	-0.7835	-1.0261	-1.2219	-1.2007	-1.0240	*****	*****	*****	*****	

Medium Radius L.E.

Run No. = 13, Point No. = 272

$C_N = 0.399$, $C_m = -0.0819$

$\alpha = 9.0^\circ$, $M_\infty = 0.851$

$R_{mac} = 48.0 \times 10^6$

Leading Edge Pressures

● starboard
○ port

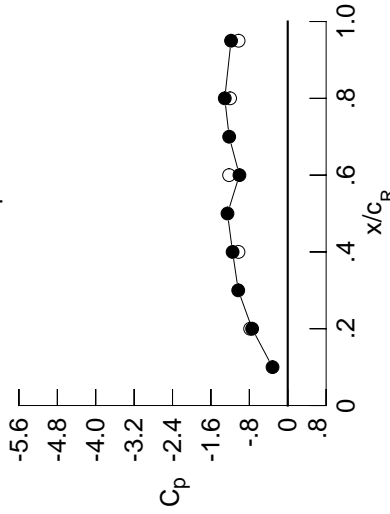

x/c_R	starb'd C_p	port C_p
0.10	-0.3166	*****
0.20	-0.7414	-0.7835
0.30	-1.0309	*****
0.40	-1.1492	-1.0261
0.50	-1.2549	*****
0.60	-1.0063	-1.2219
0.70	-1.2198	*****
0.80	-1.3119	-1.2007
0.90	-0.1326	*****
0.95	-1.1812	-1.0240

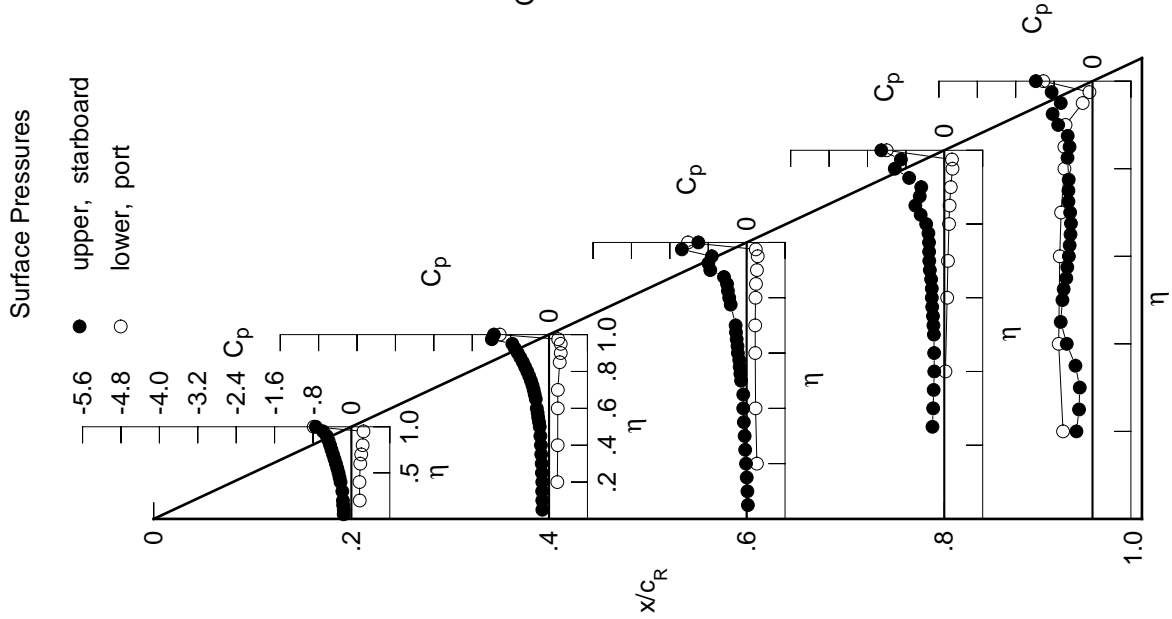

Table E5. Continued.

η	$x/c_R = .2$		$x/c_R = .4$		$x/c_R = .6$		$x/c_R = .8$		$x/c_R = .95$	
	$C_{p,u}$	$C_{p,u}$	$C_{p,u}$	$C_{p,u}$	$C_{p,u}$	$C_{p,u}$	$C_{p,u}$	$C_{p,u}$	$C_{p,u}$	$C_{p,u}$
0.050	-0.1733	-0.1578	0.0089	*****	*****	*****	*****	*****	*****	*****
0.100	-0.1742	-0.1595	-0.0017	*****	*****	*****	*****	*****	*****	*****
0.150	-0.1879	-0.1626	-0.0180	*****	*****	*****	*****	*****	*****	*****
0.200	-0.1946	-0.1604	-0.0322	*****	*****	*****	*****	*****	*****	-0.2918
0.250	*****	-0.1695	-0.0491	-0.2701	-0.2413	*****	*****	*****	*****	*****
0.300	-0.2094	-0.1749	-0.0595	-0.2530	-0.2938	*****	*****	*****	*****	*****
0.350	*****	-0.1840	-0.0757	-0.2432	-0.4165	*****	*****	*****	*****	*****
0.400	-0.2470	-0.1895	-0.0952	-0.2321	-0.5565	*****	*****	*****	*****	*****
0.450	-0.2694	-0.2090	-0.1054	-0.2441	-0.5737	*****	*****	*****	*****	*****
0.500	-0.2934	-0.2323	-0.1589	-0.2580	-0.4997	*****	*****	*****	*****	*****
0.525	*****	-0.2505	-0.1771	-0.2699	-0.4853	*****	*****	*****	*****	*****
0.550	-0.3212	-0.2687	-0.1906	-0.2807	-0.4571	*****	*****	*****	*****	*****
0.575	*****	-0.2777	-0.1944	-0.2934	-0.4498	*****	*****	*****	*****	*****
0.600	-0.3537	-0.2900	-0.2204	-0.3006	-0.4437	*****	*****	*****	*****	*****
0.625	*****	*****	-0.2230	-0.2923	-0.4561	*****	*****	*****	*****	*****
0.650	-0.3881	-0.3092	-0.2361	-0.2851	-0.4689	*****	*****	*****	*****	*****
0.675	*****	-0.3321	-0.2667	-0.2867	-0.4797	*****	*****	*****	*****	*****
0.700	-0.4235	-0.3512	-0.2937	-0.2926	-0.5398	*****	*****	*****	*****	*****
0.725	*****	-0.3745	*****	-0.3313	-0.6372	*****	*****	*****	*****	*****
0.750	-0.4604	-0.3972	*****	-0.4463	-0.7084	*****	*****	*****	*****	*****
0.775	*****	-0.4270	-0.3862	-0.6040	-0.7280	*****	*****	*****	*****	*****
0.800	-0.4983	-0.4646	-0.4254	-0.7237	*****	*****	*****	*****	*****	*****
0.825	*****	-0.5091	-0.4376	-0.7947	-0.6654	*****	*****	*****	*****	*****
0.850	-0.5473	-0.5770	-0.4188	-0.7659	-0.6106	*****	*****	*****	*****	*****
0.875	*****	-0.6975	-0.4387	-0.6744	-0.5878	*****	*****	*****	*****	*****
0.900	-0.5973	-0.7434	-1.1021	-0.6599	-0.5791	*****	*****	*****	*****	*****
0.925	*****	-0.9336	-1.1629	-0.8234	-0.5886	*****	*****	*****	*****	*****
0.950	-0.7003	-1.2133	-1.0370	-0.9044	-0.5985	*****	*****	*****	*****	*****
0.975	*****	-1.3752	-1.1925	-0.7508	-0.6377	*****	*****	*****	*****	*****
1.000	-0.9109	-1.2494	-1.0268	-1.3039	-0.9445	*****	*****	*****	*****	*****
-0.200	$C_{p,l}$	0.2014	0.1975	0.2351	*****	*****	*****	*****	*****	-0.6183
-0.400		0.1979	0.2059	0.2055	0.0409	-0.6948	*****	*****	*****	*****
-0.600		0.2163	0.2090	0.2009	0.0768	-0.6718	*****	*****	*****	*****
-0.700		0.2354	0.2115	0.2006	0.0942	-0.6428	*****	*****	*****	*****
-0.800		0.2621	*****	0.2083	0.1185	-0.5725	*****	*****	*****	*****
-0.850		*****	0.2491	0.2177	0.1306	-0.5708	*****	*****	*****	*****
-0.900		*****	0.2647	0.2358	0.1548	-0.5405	*****	*****	*****	*****
-0.950		0.2528	0.2506	0.2404	0.1823	-0.1898	*****	*****	*****	*****
-0.975		*****	0.1784	0.1864	0.1594	-0.0556	*****	*****	*****	*****
-1.000		-0.9612	-1.1078	-1.2554	-1.1820	-0.9639	*****	*****	*****	*****

Medium Radius L.E.
 Run No. = 13, Point No. = 273
 $C_N = 0.452$, $C_m = -0.0902$
 $\alpha = 10.1^\circ$, $M_\infty = 0.851$
 $R_{mac} = 47.8 \times 10^6$

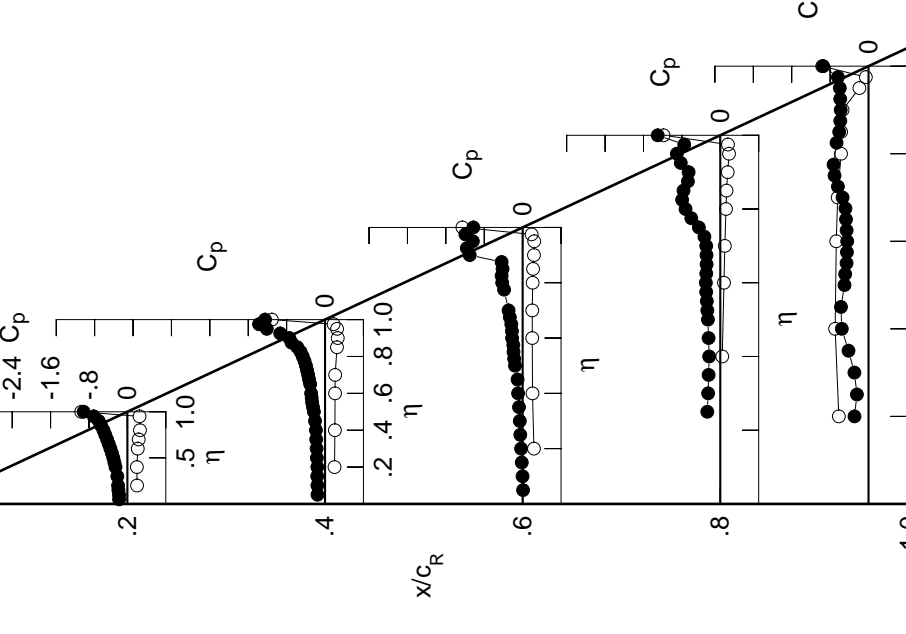
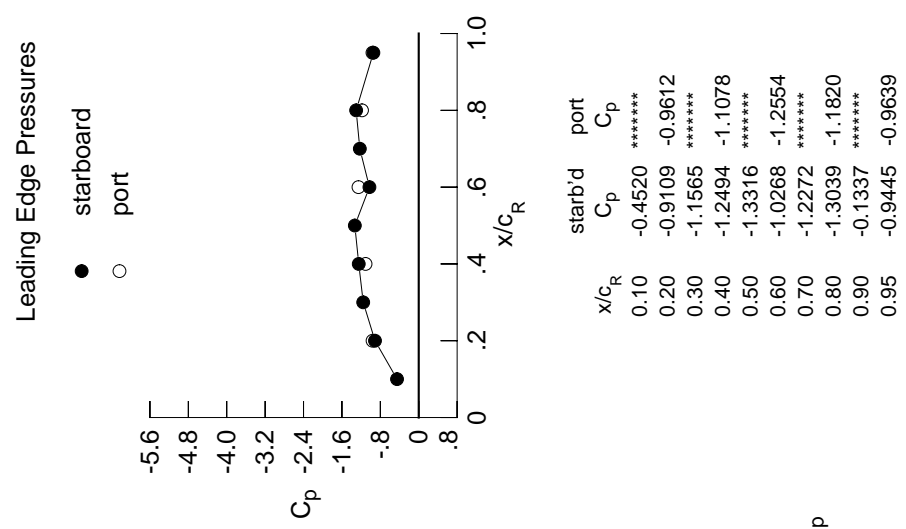
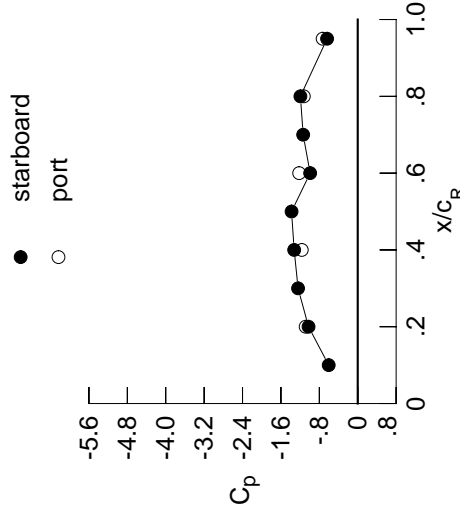

Table E5. Continued.

η	$x/c_R = .2$		$x/c_R = .4$		$x/c_R = .6$		$x/c_R = .8$		$x/c_R = .95$	
	$C_{p,u}$	$C_{p,u}$	$C_{p,u}$	$C_{p,u}$	$C_{p,u}$	$C_{p,u}$	$C_{p,u}$	$C_{p,u}$	$C_{p,u}$	$C_{p,u}$
0.050	-0.1901	-0.1860	-0.0181	*****	*****	*****	*****	*****	*****	*****
0.100	-0.1887	-0.1864	-0.0304	*****	*****	*****	*****	*****	*****	*****
0.150	-0.2091	-0.1921	-0.0466	*****	*****	*****	*****	*****	*****	*****
0.200	-0.2152	-0.1893	-0.0620	*****	*****	*****	*****	*****	*****	-0.2468
0.250	*****	-0.2000	-0.0758	-0.3006	-0.3006	-0.2574	*****	*****	*****	-0.2574
0.300	-0.2341	-0.2009	-0.0883	-0.2836	-0.2836	-0.3635	*****	*****	*****	-0.3635
0.350	*****	-0.2147	-0.1108	-0.2751	-0.2751	-0.4765	*****	*****	*****	-0.4765
0.400	-0.2717	-0.2306	-0.1401	-0.2666	-0.2666	-0.5816	*****	*****	*****	-0.5816
0.450	-0.2968	-0.2667	-0.1592	-0.2687	-0.2687	-0.6016	*****	*****	*****	-0.6016
0.500	-0.3229	-0.2865	-0.1943	-0.2825	-0.2825	-0.5750	*****	*****	*****	-0.5750
0.525	*****	-0.2958	-0.2065	-0.2861	-0.2861	-0.5916	*****	*****	*****	-0.5916
0.550	-0.3539	-0.3021	-0.2258	-0.2818	-0.2818	-0.5958	*****	*****	*****	-0.5958
0.575	*****	-0.3050	-0.2532	-0.2879	-0.2879	-0.6247	*****	*****	*****	-0.6247
0.600	-0.3893	-0.3155	-0.3101	-0.3007	-0.3007	-0.6286	*****	*****	*****	-0.6286
0.625	*****	*****	-0.3206	-0.3200	-0.3200	-0.6480	*****	*****	*****	-0.6480
0.650	-0.4276	-0.3703	-0.3248	-0.3667	-0.3667	-0.6948	*****	*****	*****	-0.6948
0.675	*****	-0.4130	-0.3348	-0.4550	-0.4550	-0.7583	*****	*****	*****	-0.7583
0.700	-0.4697	-0.4206	-0.3511	-0.5841	-0.5841	-0.8208	*****	*****	*****	-0.8208
0.725	*****	-0.4342	*****	-0.7419	-0.8624	*****	*****	*****	*****	-0.8624
0.750	-0.5158	-0.4381	*****	-0.8511	-0.8604	*****	*****	*****	*****	-0.8604
0.775	*****	-0.4537	-0.6335	-0.8933	-0.8933	-0.7934	*****	*****	*****	-0.7934
0.800	-0.5669	-0.4894	-0.6862	-0.8846	-0.8846	*****	*****	*****	*****	-0.8846
0.825	*****	-0.6185	-0.7059	-0.8656	-0.8656	-0.5973	*****	*****	*****	-0.5973
0.850	-0.6118	-0.8748	-0.7842	-0.8192	-0.8192	-0.5438	*****	*****	*****	-0.5438
0.875	*****	-0.9515	-0.9811	-0.7943	-0.5276	*****	*****	*****	*****	-0.5276
0.900	-0.6736	-0.8804	-1.0755	-0.8014	-0.5354	*****	*****	*****	*****	-0.5354
0.925	*****	-0.9681	-1.0536	-0.8066	-0.5401	*****	*****	*****	*****	-0.5401
0.950	-0.7827	-1.3773	-0.9985	-0.7610	-0.4933	*****	*****	*****	*****	-0.4933
0.975	*****	-1.4087	-0.9570	-0.6714	-0.4018	*****	*****	*****	*****	-0.4018
1.000	-1.0247	-1.3243	-0.9913	-1.1941	-0.6386	*****	*****	*****	*****	-0.6386
-0.200	$C_{p,l}$	$C_{p,l}$	$C_{p,l}$	$C_{p,l}$	$C_{p,l}$	$C_{p,l}$	$C_{p,l}$	$C_{p,l}$	$C_{p,l}$	$C_{p,l}$
-0.400	0.2289	0.2215	0.2520	*****	*****	-0.6136	*****	*****	*****	-0.6136
-0.600	0.2268	0.2299	0.2262	0.0566	-0.6838	*****	*****	*****	*****	-0.6838
-0.700	0.2457	0.2345	0.2205	0.0938	-0.6609	*****	*****	*****	*****	-0.6609
-0.800	0.2644	0.2380	0.2231	0.1100	-0.6301	*****	*****	*****	*****	-0.6301
-0.850	0.2872	*****	0.2304	0.1355	-0.5592	*****	*****	*****	*****	-0.5592
-0.900	*****	0.2720	0.2396	0.1463	-0.5555	*****	*****	*****	*****	-0.5555
-0.950	*****	0.2820	0.2551	0.1699	-0.5237	*****	*****	*****	*****	-0.5237
-0.975	0.2510	0.2535	0.2487	0.1896	-0.1780	*****	*****	*****	*****	-0.1780
-1.000	*****	0.1640	0.1822	0.1561	-0.0466	*****	*****	*****	*****	-0.0466
	-1.0849	-1.1653	-1.2198	-1.1234	-0.7310	*****	*****	*****	*****	-0.7310

Medium Radius L.E.
 Run No. = 13, Point No. = 274
 $C_N = 0.520$, $C_m = -0.1044$
 $\alpha = 11.1^\circ$, $M_\infty = 0.851$
 $R_{mac} = 48.0 \times 10^6$

Leading Edge Pressures



x/c_R	starb'd C_p	port C_p
0.10	-0.6046	*****
0.20	-1.0247	-1.0849
0.30	-1.2428	*****
0.40	-1.3243	-1.1653
0.50	-1.3788	*****
0.60	-0.9913	-1.2198
0.70	-1.1371	*****
0.80	-1.1941	-1.1234
0.90	-0.1281	*****
0.95	-0.6386	-0.7310

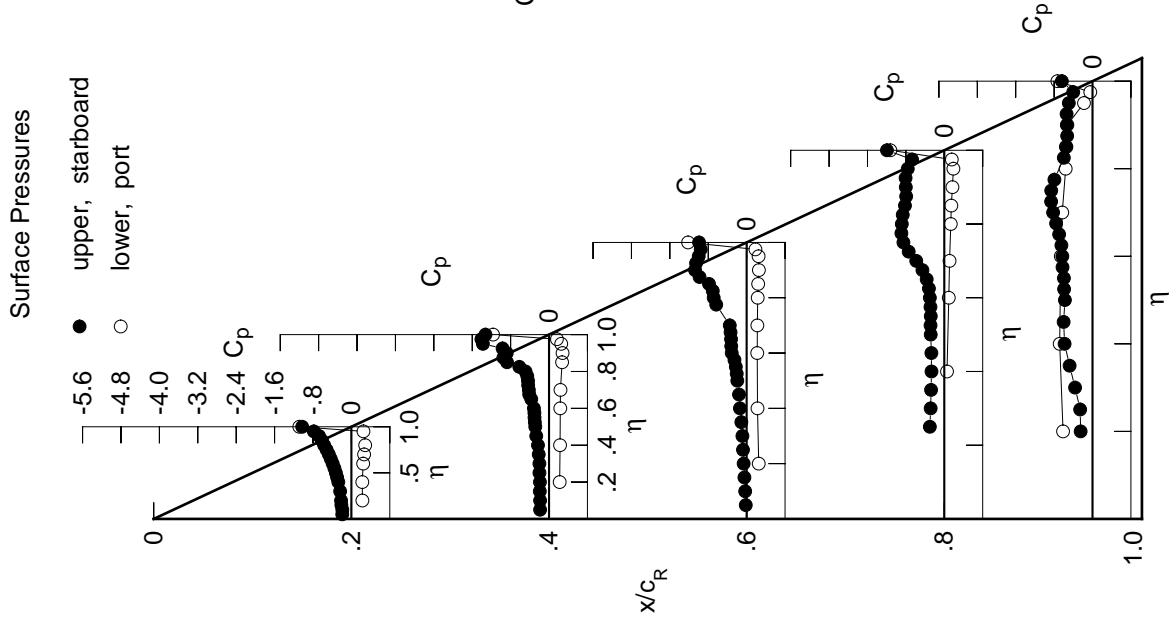
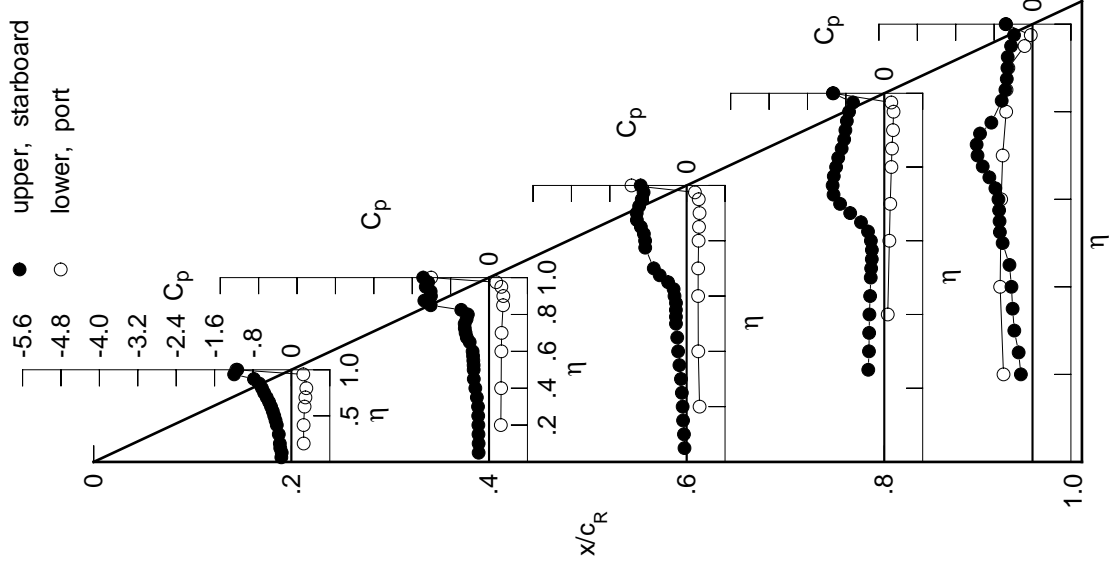

Table E5. Continued.

η	$x/c_R = .2$		$x/c_R = .4$		$x/c_R = .6$		$x/c_R = .8$		$x/c_R = .95$	
	$C_{p,u}$	$C_{p,u}$	$C_{p,u}$	$C_{p,u}$	$C_{p,u}$	$C_{p,u}$	$C_{p,u}$	$C_{p,u}$	$C_{p,u}$	$C_{p,u}$
0.050	-0.2096	-0.2166	-0.0450	*****	*****	*****	*****	*****	*****	*****
0.100	-0.2013	-0.2164	-0.0558	*****	*****	*****	*****	*****	*****	*****
0.150	-0.2320	-0.2200	-0.0742	*****	*****	*****	*****	*****	*****	*****
0.200	-0.2407	-0.2227	-0.0836	*****	*****	*****	*****	*****	*****	-0.2427
0.250	*****	-0.2257	-0.1003	-0.3336	-0.3336	-0.2886	*****	*****	*****	-0.2886
0.300	-0.2621	-0.2296	-0.1182	-0.3189	-0.3189	-0.3795	*****	*****	*****	-0.3795
0.350	*****	-0.2532	-0.1500	-0.3152	-0.4147	*****	*****	*****	*****	-0.4147
0.400	-0.3038	-0.2852	-0.1779	-0.3092	-0.4382	*****	*****	*****	*****	-0.4382
0.450	-0.3297	-0.3176	-0.1959	-0.2950	-0.4801	*****	*****	*****	*****	-0.4801
0.500	-0.3575	-0.3204	-0.2224	-0.2827	-0.6225	*****	*****	*****	*****	-0.6225
0.525	*****	-0.3217	-0.2233	-0.2739	-0.6800	*****	*****	*****	*****	-0.6800
0.550	-0.3881	-0.3274	-0.2241	-0.2599	-0.6862	*****	*****	*****	*****	-0.6862
0.575	*****	-0.3327	-0.2226	-0.2587	-0.6963	*****	*****	*****	*****	-0.6963
0.600	-0.4236	-0.3428	-0.2528	-0.2791	-0.7096	*****	*****	*****	*****	-0.7096
0.625	*****	*****	-0.2708	-0.3395	-0.7740	*****	*****	*****	*****	-0.7740
0.650	-0.4649	-0.4030	-0.3863	-0.4855	-0.8992	*****	*****	*****	*****	-0.8992
0.675	*****	-0.4631	-0.5604	-0.7101	-1.0378	*****	*****	*****	*****	-1.0378
0.700	-0.5144	-0.4876	-0.6848	-0.9210	-1.1456	*****	*****	*****	*****	-1.1456
0.725	*****	-0.5050	*****	-1.0565	-1.1637	*****	*****	*****	*****	-1.1637
0.750	-0.5680	-0.5069	*****	-1.0759	-1.0933	*****	*****	*****	*****	-1.0933
0.775	*****	-0.4670	-0.8633	-1.0523	-0.8579	*****	*****	*****	*****	-0.8579
0.800	-0.6135	-0.4416	-0.8655	-1.0040	*****	*****	*****	*****	*****	-1.0040
0.825	*****	-0.5796	-0.8912	-0.9601	-0.6423	*****	*****	*****	*****	-0.6423
0.850	-0.6691	-1.2154	-0.9534	-0.8883	-0.5648	*****	*****	*****	*****	-0.5648
0.875	*****	-1.3483	-1.0369	-0.8361	-0.5359	*****	*****	*****	*****	-0.5359
0.900	-0.7797	-1.2105	-1.0402	-0.8104	-0.5234	*****	*****	*****	*****	-0.5234
0.925	*****	-1.2160	-0.9894	-0.7803	-0.5164	*****	*****	*****	*****	-0.5164
0.950	-1.1926	-1.3184	-0.9354	-0.7343	-0.4460	*****	*****	*****	*****	-0.4460
0.975	*****	-1.2693	-0.8971	-0.6511	-0.3844	*****	*****	*****	*****	-0.3844
1.000	-1.1273	-1.3721	-0.9575	-1.0712	-0.5523	*****	*****	*****	*****	-0.5523
-0.200	$C_{p,l}$	$C_{p,l}$	$C_{p,l}$	$C_{p,l}$	$C_{p,l}$	$C_{p,l}$	$C_{p,l}$	$C_{p,l}$	$C_{p,l}$	$C_{p,l}$
-0.400	0.2559	0.2455	0.2693	*****	*****	-0.6044	*****	*****	*****	-0.6044
-0.600	0.2548	0.2521	0.2426	0.0722	-0.6745	*****	*****	*****	*****	-0.6745
-0.700	0.2745	0.2571	0.2390	0.1059	-0.6524	*****	*****	*****	*****	-0.6524
-0.800	0.2921	0.2619	0.2402	0.1237	-0.6213	*****	*****	*****	*****	-0.6213
-0.850	0.3115	*****	0.2487	0.1479	-0.5487	*****	*****	*****	*****	-0.5487
-0.900	*****	0.2929	0.2574	0.1602	-0.5416	*****	*****	*****	*****	-0.5416
-0.950	*****	0.2978	0.2692	0.1813	-0.5029	*****	*****	*****	*****	-0.5029
-0.975	0.2478	0.2560	0.2516	0.1928	-0.1654	*****	*****	*****	*****	-0.1654
-1.000	*****	0.1488	0.1720	0.1459	-0.0361	*****	*****	*****	*****	-0.0361
	-1.1485	-1.2054	-1.1487	-1.0606	-0.5584	*****	*****	*****	*****	-0.5584

Surface Pressures

● upper, starboard
○ lower, port



Medium Radius L.E.
Run No. = 13, Point No. = 275
 $C_N = 0.582$, $C_m = -0.1156$
 $\alpha = 12.2^\circ$, $M_\infty = 0.851$
 $R_{mac} = 48.2 \times 10^6$

Leading Edge Pressures

● starboard
○ port

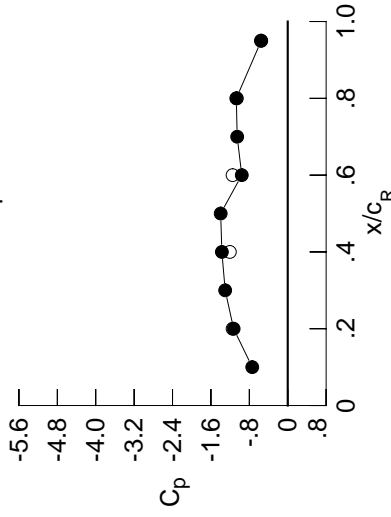

x/c_R	starb'd C_p	port C_p
0.10	-0.7392	*****
0.20	-1.1273	-1.1485
0.30	-1.3030	*****
0.40	-1.3721	-1.2054
0.50	-1.3971	*****
0.60	-0.9575	-1.1487
0.70	-1.0531	*****
0.80	-1.0712	-1.0606
0.90	-0.1150	*****
0.95	-0.5523	-0.5584

Table E5. Continued.

η	$x/c_R = .2$		$x/c_R = .4$		$x/c_R = .6$		$x/c_R = .8$		$x/c_R = .95$	
	$C_{p,u}$	$C_{p,u}$	$C_{p,u}$	$C_{p,u}$	$C_{p,u}$	$C_{p,u}$	$C_{p,u}$	$C_{p,u}$	$C_{p,u}$	$C_{p,u}$
0.050	-0.2275	-0.2541	-0.0662	*****	*****	*****	*****	*****	*****	*****
0.100	-0.2142	-0.2531	-0.0754	*****	*****	*****	*****	*****	*****	*****
0.150	-0.2492	-0.2571	-0.0936	*****	*****	*****	*****	*****	*****	*****
0.200	-0.2636	-0.2557	-0.1016	*****	*****	*****	*****	*****	*****	-0.2435
0.250	*****	-0.2589	-0.1196	-0.3582	-0.3156	*****	*****	*****	*****	-0.3156
0.300	-0.2893	-0.2735	-0.1402	-0.3444	-0.4143	*****	*****	*****	*****	-0.4143
0.350	*****	-0.3037	-0.1644	-0.3287	-0.4877	*****	*****	*****	*****	-0.4877
0.400	-0.3375	-0.3332	-0.1752	-0.3096	-0.6467	*****	*****	*****	*****	-0.6467
0.450	-0.3585	-0.3603	-0.1734	-0.2998	-0.7017	*****	*****	*****	*****	-0.7017
0.500	-0.3818	-0.3592	-0.2381	-0.2929	-0.6904	*****	*****	*****	*****	-0.6904
0.525	*****	-0.3622	-0.2707	-0.2946	-0.6909	*****	*****	*****	*****	-0.6909
0.550	-0.4134	-0.3718	-0.3020	-0.3045	-0.6922	*****	*****	*****	*****	-0.6922
0.575	*****	-0.3831	-0.3472	-0.3464	-0.7332	*****	*****	*****	*****	-0.7332
0.600	-0.4492	-0.4119	-0.4609	-0.4370	-0.8001	*****	*****	*****	*****	-0.8001
0.625	*****	*****	-0.5394	-0.5899	-0.9226	*****	*****	*****	*****	-0.9226
0.650	-0.4967	-0.5533	-0.6893	-0.8068	-1.0735	*****	*****	*****	*****	-1.0735
0.675	*****	-0.6300	-0.8335	-1.0239	-1.1961	*****	*****	*****	*****	-1.1961
0.700	-0.5515	-0.6490	-0.9320	-1.1733	-1.2767	*****	*****	*****	*****	-1.2767
0.725	*****	-0.6397	*****	-1.2413	-1.2431	*****	*****	*****	*****	-1.2431
0.750	-0.5910	-0.6480	*****	-1.1691	-0.9246	*****	*****	*****	*****	-0.9246
0.775	*****	-0.6863	-1.0015	-1.0807	-0.7730	*****	*****	*****	*****	-0.7730
0.800	-0.6348	-0.7864	-0.9769	-0.9766	*****	*****	*****	*****	*****	*****
0.825	*****	-1.0311	-0.9765	-0.9451	-0.5762	*****	*****	*****	*****	-0.5762
0.850	-0.8830	-1.2110	-0.9900	-0.8677	-0.5098	*****	*****	*****	*****	-0.5098
0.875	*****	-1.1879	-1.0080	-0.8167	-0.4844	*****	*****	*****	*****	-0.4844
0.900	-1.1656	-1.0884	-0.9802	-0.7903	-0.4798	*****	*****	*****	*****	-0.4798
0.925	*****	-1.0697	-0.9239	-0.7590	-0.4710	*****	*****	*****	*****	-0.4710
0.950	-1.2948	-1.3164	-0.8753	-0.7154	-0.4007	*****	*****	*****	*****	-0.4007
0.975	*****	-1.2877	-0.8417	-0.6458	-0.3308	*****	*****	*****	*****	-0.3308
1.000	-1.2086	-1.3940	-0.9171	-1.0157	-0.4847	*****	*****	*****	*****	-0.4847
-0.200	$C_{p,l}$	0.2871	0.2716	0.2894	*****	*****	*****	*****	*****	-0.5905
-0.400	$C_{p,l}$	0.2870	0.2795	0.2636	0.0899	0.6633	*****	*****	*****	-0.6633
-0.600	$C_{p,l}$	0.3075	0.2843	0.2600	0.1248	-0.6419	*****	*****	*****	-0.6419
-0.700	$C_{p,l}$	0.3235	0.2896	0.2616	0.1417	-0.6111	*****	*****	*****	-0.6111
-0.800	$C_{p,l}$	0.3383	*****	0.2700	0.1652	-0.5370	*****	*****	*****	-0.5370
-0.850	$C_{p,l}$	*****	0.3159	0.2776	0.1776	-0.5276	*****	*****	*****	-0.5276
-0.900	$C_{p,l}$	*****	0.3148	0.2845	0.1966	-0.4855	*****	*****	*****	-0.4855
-0.950	$C_{p,l}$	0.2476	0.2597	0.2552	0.2005	-0.1569	*****	*****	*****	-0.1569
-0.975	$C_{p,l}$	*****	0.1378	0.1628	0.1401	-0.0371	*****	*****	*****	-0.0371
-1.000	$C_{p,l}$	-1.1979	-1.1917	-1.0515	-0.9966	-0.5232	*****	*****	*****	-0.5232

Medium Radius L.E.

Run No. = 13, Point No. = 276

$C_N = 0.643$, $C_m = -0.1242$

$\alpha = 13.2^\circ$, $M_\infty = 0.851$

$R_{mac} = 48.2 \times 10^6$

Leading Edge Pressures

● starboard
○ port

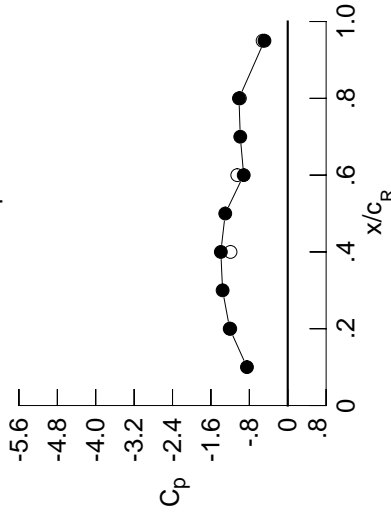

x/c_R	starb'd C_p	port C_p
0.10	-0.8493	*****
0.20	-1.2086	-1.1979
0.30	-1.3572	*****
0.40	-1.3940	-1.1917
0.50	-1.3016	*****
0.60	-0.9171	-1.0515
0.70	-0.9886	*****
0.80	-1.0157	-0.9966
0.90	-0.0994	*****
0.95	-0.4847	-0.5232

Surface Pressures

● upper, starboard
○ lower, port

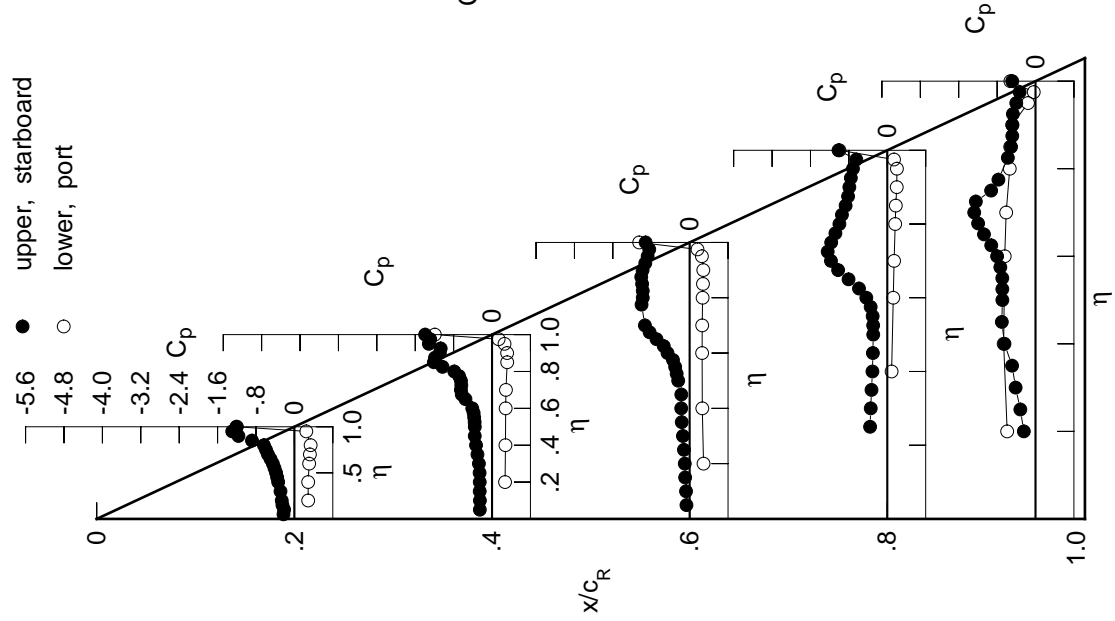
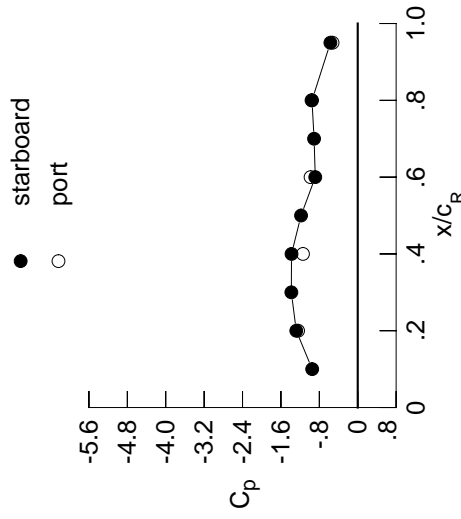

Table E5. Continued.

η	$x/c_R = .2$		$x/c_R = .4$		$x/c_R = .6$		$x/c_R = .8$		$x/c_R = .95$	
	$C_{p,u}$	$C_{p,u}$	$C_{p,u}$	$C_{p,u}$	$C_{p,u}$	$C_{p,u}$	$C_{p,u}$	$C_{p,u}$	$C_{p,u}$	$C_{p,u}$
0.050	-0.2363	-0.2839	-0.0762	*****	*****	*****	*****	*****	*****	*****
0.100	-0.2174	-0.2812	-0.0884	*****	*****	*****	*****	*****	*****	*****
0.150	-0.2529	-0.2874	-0.1000	*****	*****	*****	*****	*****	*****	*****
0.200	-0.2676	-0.2773	-0.1120	*****	*****	*****	*****	*****	*****	*****
0.250	*****	-0.2892	-0.1360	-0.3740	-0.3688	*****	*****	*****	*****	*****
0.300	-0.3238	-0.3127	-0.1500	-0.3590	-0.4418	*****	*****	*****	*****	*****
0.350	*****	-0.3344	-0.1759	-0.3502	-0.4619	*****	*****	*****	*****	*****
0.400	-0.3626	-0.3481	-0.1881	-0.3297	-0.5213	*****	*****	*****	*****	*****
0.450	-0.3806	-0.3831	-0.1760	-0.3206	-0.6161	*****	*****	*****	*****	*****
0.500	-0.3955	-0.4046	-0.1988	-0.3097	-0.6513	*****	*****	*****	*****	*****
0.525	*****	-0.4132	-0.2129	-0.3186	-0.6648	*****	*****	*****	*****	*****
0.550	-0.4220	-0.4246	-0.2485	-0.3436	-0.6811	*****	*****	*****	*****	*****
0.575	*****	-0.4347	-0.3379	-0.4142	-0.7474	*****	*****	*****	*****	*****
0.600	-0.4595	-0.4695	-0.5708	-0.5410	-0.8372	*****	*****	*****	*****	*****
0.625	*****	*****	-0.7792	-0.7370	-0.9822	*****	*****	*****	*****	*****
0.650	-0.5047	-0.6941	-0.9984	-0.9634	-1.1386	*****	*****	*****	*****	*****
0.675	*****	-0.8477	-1.1492	-1.1705	-1.2582	*****	*****	*****	*****	*****
0.700	-0.5985	-0.9448	-1.2097	-1.3135	-0.9093	*****	*****	*****	*****	*****
0.725	*****	-0.9956	*****	-1.4073	-0.8588	*****	*****	*****	*****	*****
0.750	-0.6281	-1.0501	*****	-1.4053	-0.8040	*****	*****	*****	*****	*****
0.775	*****	-1.1086	-1.1211	-1.1494	-0.7225	*****	*****	*****	*****	*****
0.800	-0.6121	-1.1390	-1.0882	-0.9979	*****	*****	*****	*****	*****	*****
0.825	*****	-1.1180	-1.0720	-0.9096	-0.5856	*****	*****	*****	*****	*****
0.850	-1.1750	-1.1043	-1.0307	-0.8712	-0.5362	*****	*****	*****	*****	*****
0.875	*****	-1.1180	-0.9940	-0.8662	-0.5639	*****	*****	*****	*****	*****
0.900	-1.3521	-1.0940	-0.9409	-0.8647	-0.5378	*****	*****	*****	*****	*****
0.925	*****	-1.0850	-0.8955	-0.7611	-0.5412	*****	*****	*****	*****	*****
0.950	-1.3768	-1.2298	-0.8474	-0.7106	-0.4982	*****	*****	*****	*****	*****
0.975	*****	-1.1417	-0.8105	-0.6582	-0.4227	*****	*****	*****	*****	*****
1.000	-1.2803	-1.3795	-0.8844	-0.9532	-0.5693	*****	*****	*****	*****	*****
-0.200	$C_{p,l}$	$C_{p,l}$	$C_{p,l}$	$C_{p,l}$	$C_{p,l}$	$C_{p,l}$	$C_{p,l}$	$C_{p,l}$	$C_{p,l}$	$C_{p,l}$
-0.400	0.3235	0.3043	0.3137	*****	-0.5692	*****	*****	*****	*****	*****
-0.600	0.3215	0.3104	0.2900	0.1112	-0.6455	*****	*****	*****	*****	*****
-0.700	0.3405	0.3168	0.2858	0.1472	-0.6243	*****	*****	*****	*****	*****
-0.800	0.3551	0.3173	0.2873	0.1638	-0.5947	*****	*****	*****	*****	*****
-0.850	0.3646	*****	0.2914	0.1861	-0.5176	*****	*****	*****	*****	*****
-0.900	*****	0.3387	0.2970	0.1937	-0.5123	*****	*****	*****	*****	*****
-0.950	*****	0.3310	0.2992	0.2110	-0.4675	*****	*****	*****	*****	*****
-0.975	0.2462	0.2628	0.2583	0.2027	-0.1495	*****	*****	*****	*****	*****
-1.000	*****	0.1275	0.1531	0.1313	-0.0421	*****	*****	*****	*****	*****
	-1.2421	-1.1411	-0.9822	-0.9622	-0.5246	*****	*****	*****	*****	*****

Medium Radius L.E.
 Run No. = 13, Point No. = 277
 $C_N = 0.702$, $C_m = -0.1314$
 $\alpha = 14.3^\circ$, $M_\infty = 0.851$
 $R_{mac} = 48.3 \times 10^6$

Leading Edge Pressures



x/c_R	starb'd C_p	port C_p
0.10	-0.9485	*****
0.20	-1.2803	-1.2421
0.30	-1.3832	*****
0.40	-1.3795	-1.1411
0.50	-1.1810	*****
0.60	-0.8844	-0.9822
0.70	-0.9093	*****
0.80	-0.9532	-0.9622
0.90	-0.0749	*****
0.95	-0.5693	-0.5246

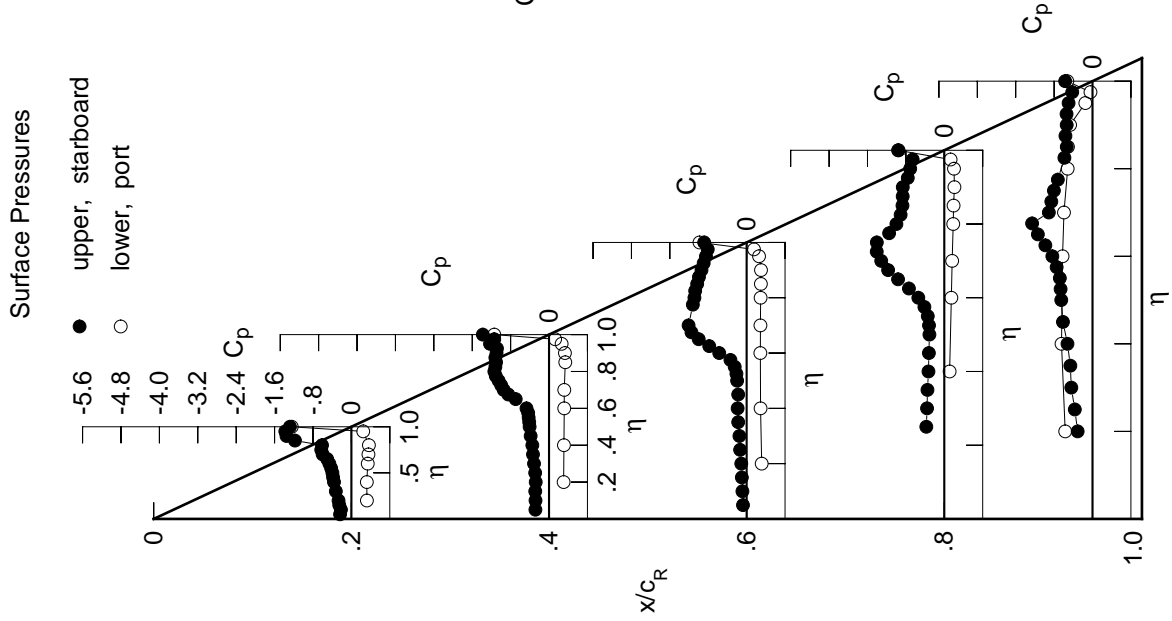
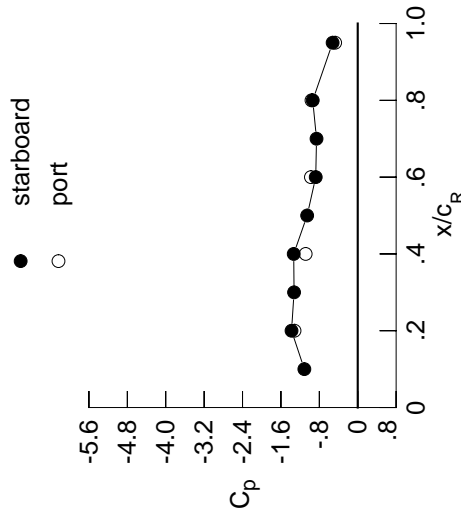

Table E5. Continued.

η	$x/c_R = .2$		$x/c_R = .4$		$x/c_R = .6$		$x/c_R = .8$		$x/c_R = .95$	
	$C_{p,u}$	$C_{p,u}$	$C_{p,u}$	$C_{p,u}$	$C_{p,u}$	$C_{p,u}$	$C_{p,u}$	$C_{p,u}$	$C_{p,u}$	$C_{p,u}$
0.050	-0.3038	-0.3539	-0.1095	*****	*****	*****	*****	*****	*****	*****
0.100	-0.2793	-0.3554	-0.1203	*****	*****	*****	*****	*****	*****	*****
0.150	-0.3112	-0.3482	-0.1317	*****	*****	*****	*****	*****	*****	*****
0.200	-0.3232	-0.3523	-0.1528	*****	*****	*****	*****	*****	*****	-0.6074
0.250	*****	-0.3784	-0.1785	-0.4346	-0.5954	*****	*****	*****	*****	*****
0.300	-0.4217	-0.3829	-0.1815	-0.4244	-0.5236	*****	*****	*****	*****	*****
0.350	*****	-0.3787	-0.1858	-0.4094	-0.5603	*****	*****	*****	*****	*****
0.400	-0.4390	-0.3698	-0.1968	-0.3981	-0.6776	*****	*****	*****	*****	*****
0.450	-0.4544	-0.3702	-0.1912	-0.4090	-0.7025	*****	*****	*****	*****	*****
0.500	-0.4769	-0.4098	-0.3042	-0.4681	-0.7410	*****	*****	*****	*****	*****
0.525	*****	-0.5069	-0.4141	-0.5366	-0.7872	*****	*****	*****	*****	*****
0.550	-0.4881	-0.6643	-0.5825	-0.6376	-0.8514	*****	*****	*****	*****	*****
0.575	*****	-0.8634	-0.7813	-0.7808	-0.9619	*****	*****	*****	*****	*****
0.600	-0.4946	-1.0320	-1.0337	-0.9382	-1.0779	*****	*****	*****	*****	*****
0.625	*****	*****	-1.1959	-1.1014	-1.1895	*****	*****	*****	*****	*****
0.650	-0.6500	-1.2209	-1.3254	-1.2513	-0.7821	*****	*****	*****	*****	*****
0.675	*****	-1.2631	-1.4157	-1.3743	-0.7513	*****	*****	*****	*****	*****
0.700	-1.0036	-1.3102	-1.4331	-1.4608	-0.7139	*****	*****	*****	*****	*****
0.725	*****	-1.3275	*****	-1.2302	-0.6498	*****	*****	*****	*****	*****
0.750	-1.0249	-1.3282	*****	-1.1639	-0.5839	*****	*****	*****	*****	*****
0.775	*****	-1.3077	-1.2261	-1.1621	-0.5317	*****	*****	*****	*****	*****
0.800	-1.2073	-1.2301	-1.1552	-1.1874	*****	*****	*****	*****	*****	*****
0.825	*****	-1.1483	-1.0679	-1.1151	-0.5044	*****	*****	*****	*****	*****
0.850	-1.4168	-1.1098	-1.0115	-1.0632	-0.4919	*****	*****	*****	*****	*****
0.875	*****	-1.1174	-0.9955	-0.9979	-0.5261	*****	*****	*****	*****	*****
0.900	-1.3734	-1.1386	-0.9918	-0.9108	-0.5250	*****	*****	*****	*****	*****
0.925	*****	-1.1613	-0.9497	-0.7863	-0.5489	*****	*****	*****	*****	*****
0.950	-1.3086	-1.1638	-0.8879	-0.7777	-0.4991	*****	*****	*****	*****	*****
0.975	*****	-1.0347	-0.8455	-0.7333	-0.4294	*****	*****	*****	*****	*****
1.000	-1.3790	-1.3336	-0.8750	-0.9374	-0.5229	*****	*****	*****	*****	*****
-0.200	$C_{p,l}$	$C_{p,l}$	$C_{p,l}$	$C_{p,l}$	$C_{p,l}$	$C_{p,l}$	$C_{p,l}$	$C_{p,l}$	$C_{p,l}$	$C_{p,l}$
-0.400	0.3834	0.3502	0.3505	*****	*****	*****	*****	*****	*****	-0.5529
-0.600	0.3804	0.3583	0.3249	0.1424	-0.6285	*****	*****	*****	*****	*****
-0.700	0.3979	0.3626	0.3222	0.1761	-0.6082	*****	*****	*****	*****	*****
-0.800	0.4072	0.3635	0.3231	0.1912	-0.5748	*****	*****	*****	*****	*****
-0.850	0.4067	*****	0.3241	0.2125	-0.4960	*****	*****	*****	*****	*****
-0.900	*****	0.3732	0.3251	0.2175	-0.4858	*****	*****	*****	*****	*****
-0.950	0.2356	0.2587	0.2489	0.1969	-0.1358	*****	*****	*****	*****	*****
-0.975	*****	0.0954	0.1160	0.0992	-0.0498	*****	*****	*****	*****	*****
-1.000	-1.3168	-1.0845	-0.9748	-0.9634	-0.4703	*****	*****	*****	*****	*****

Medium Radius L.E.
 Run No. = 13, Point No. = 278
 $C_N = 0.814$, $C_m = -0.1454$
 $\alpha = 16.4^\circ$, $M_\infty = 0.851$
 $R_{mac} = 48.4 \times 10^6$

Leading Edge Pressures



x/c_R	starb'd C_p	port C_p
0.10	-1.1122	*****
0.20	-1.3790	-1.3168
0.30	-1.3266	*****
0.40	-1.3336	-1.0845
0.50	-1.0539	*****
0.60	-0.8750	-0.9748
0.70	-0.8586	*****
0.80	-0.9374	-0.9634
0.90	-0.0459	*****
0.95	-0.5229	-0.4703

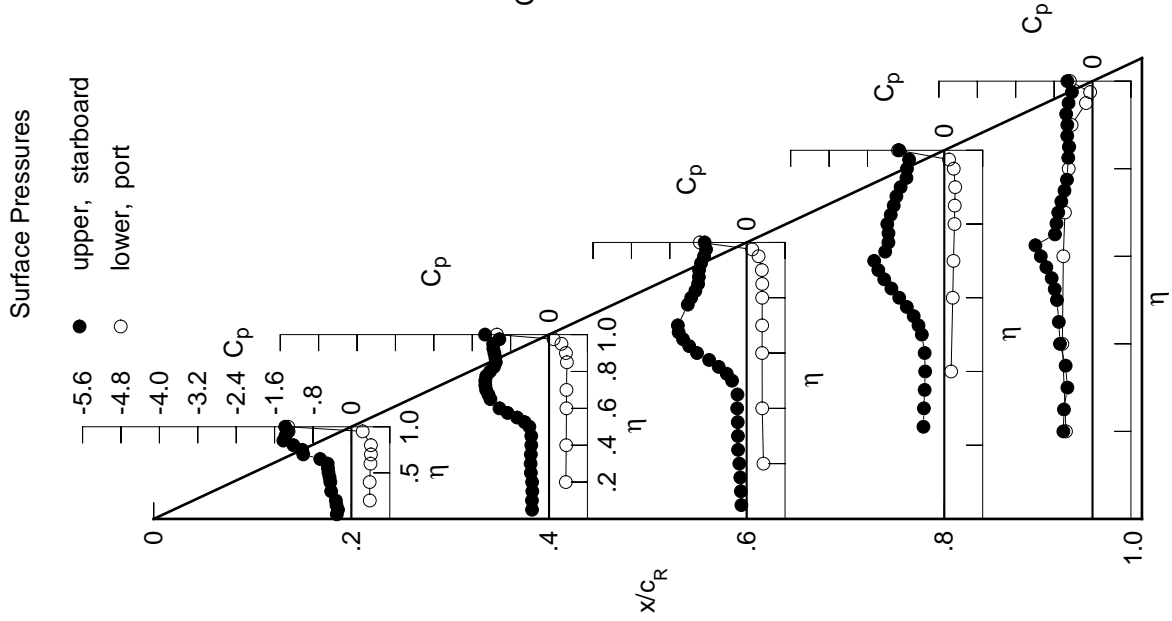
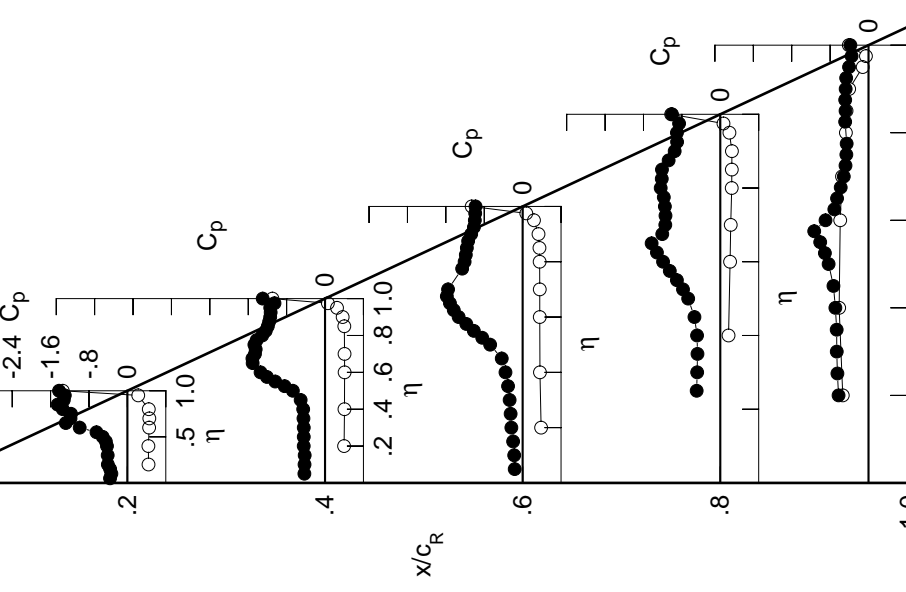
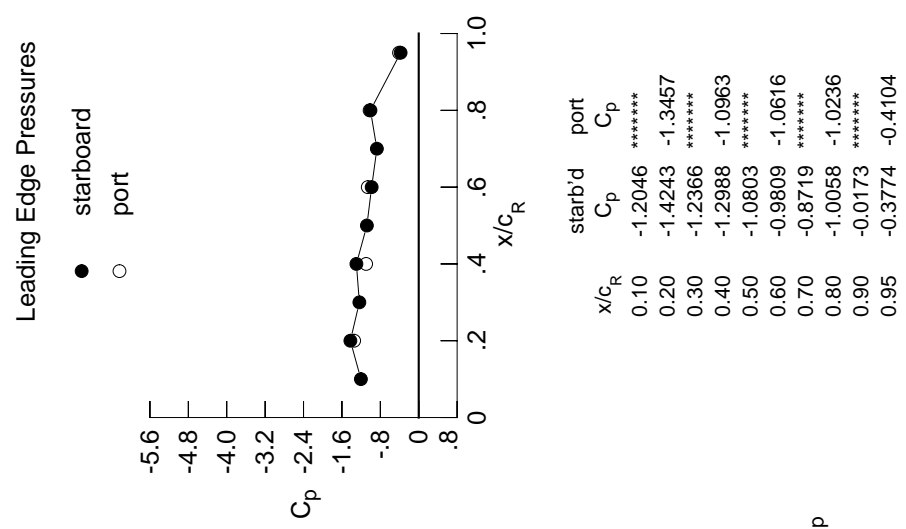

Table E5. Continued.

η	$x/c_R = .2$		$x/c_R = .4$		$x/c_R = .6$		$x/c_R = .8$		$x/c_R = .95$	
	$C_{p,u}$	$C_{p,u}$	$C_{p,u}$	$C_{p,u}$	$C_{p,u}$	$C_{p,u}$	$C_{p,u}$	$C_{p,u}$	$C_{p,u}$	$C_{p,u}$
0.050	-0.3615	-0.4301	-0.1656	*****	*****	*****	*****	*****	*****	*****
0.100	-0.3332	-0.4271	-0.1763	*****	*****	*****	*****	*****	*****	*****
0.150	-0.3593	-0.4243	-0.1986	*****	*****	*****	*****	*****	*****	*****
0.200	-0.4071	-0.4438	-0.2349	*****	*****	*****	*****	*****	*****	*****
0.250	*****	-0.4435	-0.2508	-0.4922	-0.4922	-0.4922	-0.6479	-0.6479	-0.6243	-0.6243
0.300	-0.4104	-0.4431	-0.2709	-0.4819	-0.4819	-0.6615	-0.6615	-0.6615	-0.6615	-0.6615
0.350	*****	-0.4493	-0.3041	-0.4754	-0.6630	-0.6630	-0.6630	-0.6630	-0.6630	-0.6630
0.400	-0.4254	-0.4555	-0.3578	-0.4836	-0.6905	-0.6905	-0.6905	-0.6905	-0.6905	-0.6905
0.450	-0.4487	-0.5078	-0.4352	-0.5383	-0.7300	-0.7300	-0.7300	-0.7300	-0.7300	-0.7300
0.500	-0.5142	-0.6708	-0.6768	-0.6687	-0.8311	-0.8311	-0.8311	-0.8311	-0.8311	-0.8311
0.525	*****	-0.8424	-0.8418	-0.7768	-0.9085	-0.9085	-0.9085	-0.9085	-0.9085	-0.9085
0.550	-0.6437	-1.0375	-1.0165	-0.9038	-1.0065	-1.0065	-1.0065	-1.0065	-1.0065	-1.0065
0.575	*****	-1.2102	-1.1733	-1.0518	-1.1310	-1.1310	-1.1310	-1.1310	-1.1310	-1.1310
0.600	-0.9934	-1.3429	-1.3332	-1.1920	-0.8954	-0.8954	-0.8954	-0.8954	-0.8954	-0.8954
0.625	*****	*****	-1.4347	-1.3201	-0.7121	-0.7121	-0.7121	-0.7121	-0.7121	-0.7121
0.650	-1.2831	-1.5082	-1.5142	-1.4301	-0.6554	-0.6554	-0.6554	-0.6554	-0.6554	-0.6554
0.675	*****	-1.5129	-1.5788	-1.2089	-0.5792	-0.5792	-0.5792	-0.5792	-0.5792	-0.5792
0.700	-1.1850	-1.4603	-1.5536	-1.1454	-0.5153	-0.5153	-0.5153	-0.5153	-0.5153	-0.5153
0.725	*****	-1.4449	*****	-1.1418	-0.4792	-0.4792	-0.4792	-0.4792	-0.4792	-0.4792
0.750	-1.1741	-1.4719	*****	-1.1541	-0.4613	-0.4613	-0.4613	-0.4613	-0.4613	-0.4613
0.775	*****	-1.4251	-1.2603	-1.1770	-0.4550	-0.4550	-0.4550	-0.4550	-0.4550	-0.4550
0.800	-1.3464	-1.3078	-1.2090	-1.2415	*****	*****	*****	*****	*****	*****
0.825	*****	-1.2355	-1.1839	-1.2191	-0.4864	-0.4864	-0.4864	-0.4864	-0.4864	-0.4864
0.850	-1.4536	-1.1921	-1.1623	-1.2149	-0.4782	-0.4782	-0.4782	-0.4782	-0.4782	-0.4782
0.875	*****	-1.1639	-1.1356	-1.0763	-0.4859	-0.4859	-0.4859	-0.4859	-0.4859	-0.4859
0.900	-1.3251	-1.1426	-1.0720	-0.9504	-0.4763	-0.4763	-0.4763	-0.4763	-0.4763	-0.4763
0.925	*****	-1.1327	-1.0154	-0.9003	-0.4656	-0.4656	-0.4656	-0.4656	-0.4656	-0.4656
0.950	-1.3039	-1.1415	-0.9960	-0.9032	-0.4053	-0.4053	-0.4053	-0.4053	-0.4053	-0.4053
0.975	*****	-1.0524	-0.9876	-0.8586	-0.3522	-0.3522	-0.3522	-0.3522	-0.3522	-0.3522
1.000	-1.4243	-1.2988	-0.9809	-1.0058	-0.3774	-0.3774	-0.3774	-0.3774	-0.3774	-0.3774
-0.200	$C_{p,l}$	$C_{p,l}$	$C_{p,l}$	$C_{p,l}$	$C_{p,l}$	$C_{p,l}$	$C_{p,l}$	$C_{p,l}$	$C_{p,l}$	$C_{p,l}$
-0.400	0.4400	0.3972	0.3849	*****	-0.5362	-0.5362	-0.5362	-0.5362	-0.5362	-0.5362
-0.600	0.4376	0.4051	0.3607	0.1720	-0.6116	-0.6116	-0.6116	-0.6116	-0.6116	-0.6116
-0.700	0.4527	0.4077	0.3565	0.2042	-0.5894	-0.5894	-0.5894	-0.5894	-0.5894	-0.5894
-0.800	0.4566	0.4064	0.3565	0.2173	-0.5519	-0.5519	-0.5519	-0.5519	-0.5519	-0.5519
-0.850	0.4457	*****	0.3541	0.2383	-0.4714	-0.4714	-0.4714	-0.4714	-0.4714	-0.4714
-0.900	*****	0.4018	0.3503	0.2400	-0.4578	-0.4578	-0.4578	-0.4578	-0.4578	-0.4578
-0.950	*****	0.3670	0.3301	0.2423	-0.4031	-0.4031	-0.4031	-0.4031	-0.4031	-0.4031
-0.975	0.2258	0.2496	0.2358	0.1901	-0.1209	-0.1209	-0.1209	-0.1209	-0.1209	-0.1209
-1.000	*****	0.0596	0.0761	0.0661	-0.0534	-0.0534	-0.0534	-0.0534	-0.0534	-0.0534
-1.000	-1.3457	-1.0963	-1.0616	-1.0236	-0.4104	-0.4104	-0.4104	-0.4104	-0.4104	-0.4104

Medium Radius L.E.
 Run No. = 13, Point No. = 279
 $C_N = 0.910$, $C_m = -0.1522$
 $\alpha = 18.5^\circ$, $M_\infty = 0.850$
 $R_{mac} = 48.3 \times 10^6$



x/c_R	starb'd C_p	port C_p
0.10	-1.2046	*****
0.20	-1.4243	-1.3457
0.30	-1.2366	*****
0.40	-1.2988	-1.0963
0.50	-1.0803	*****
0.60	-0.9809	-1.0616
0.70	-0.8719	*****
0.80	-1.0058	-1.0236
0.90	-0.0173	*****
0.95	-0.3774	-0.4104

Table E5. Continued.

η	$x/c_R = .2$		$x/c_R = .4$		$x/c_R = .6$		$x/c_R = .8$		$x/c_R = .95$	
	$C_{p,u}$	$C_{p,u}$	$C_{p,u}$	$C_{p,u}$	$C_{p,u}$	$C_{p,u}$	$C_{p,u}$	$C_{p,u}$	$C_{p,u}$	$C_{p,u}$
0.050	-0.4184	-0.4949	-0.0636	*****	*****	*****	*****	*****	*****	*****
0.100	-0.3839	-0.4908	-0.0687	*****	*****	*****	*****	*****	*****	*****
0.150	-0.4455	-0.4996	-0.0794	*****	*****	*****	*****	*****	*****	*****
0.200	-0.4489	-0.5079	-0.1043	*****	*****	*****	*****	*****	*****	*****
0.250	*****	-0.5130	-0.1130	-0.4811	-0.5209	*****	*****	*****	*****	*****
0.300	-0.4503	-0.5167	-0.1288	-0.5025	-0.5513	*****	*****	*****	*****	*****
0.350	*****	-0.5355	-0.1724	-0.5536	-0.6086	*****	*****	*****	*****	*****
0.400	-0.4768	-0.5795	-0.2618	-0.6044	-0.6839	*****	*****	*****	*****	*****
0.450	-0.4924	-0.7162	-0.3913	-0.7028	-0.7310	*****	*****	*****	*****	*****
0.500	-0.5669	-0.9545	-0.6922	-0.8009	-0.7077	*****	*****	*****	*****	*****
0.525	*****	-1.1076	-0.8655	-0.8351	-0.7190	*****	*****	*****	*****	*****
0.550	-0.9644	-1.2632	-1.0257	-0.8539	-0.6955	*****	*****	*****	*****	*****
0.575	*****	-1.3869	-1.1706	-0.8707	-0.7099	*****	*****	*****	*****	*****
0.600	-1.4612	-1.4819	-1.3268	-0.8785	-0.6971	*****	*****	*****	*****	*****
0.625	*****	*****	-1.4107	-0.8714	-0.6936	*****	*****	*****	*****	*****
0.650	-1.6648	-1.6392	-1.3646	-0.8662	-0.6890	*****	*****	*****	*****	*****
0.675	*****	-1.6847	-1.1598	-0.8473	-0.6718	*****	*****	*****	*****	*****
0.700	-1.4838	-1.6289	-1.1212	-0.8092	-0.6653	*****	*****	*****	*****	*****
0.725	*****	-1.5281	*****	-0.7793	-0.6563	*****	*****	*****	*****	*****
0.750	-1.3992	-1.4823	*****	-0.7411	-0.6375	*****	*****	*****	*****	*****
0.775	*****	-1.4272	-1.0644	-0.7185	-0.6223	*****	*****	*****	*****	*****
0.800	-1.4626	-1.3647	-1.0998	-0.7304	*****	*****	*****	*****	*****	*****
0.825	*****	-1.3160	-1.1866	-0.7230	-0.5791	*****	*****	*****	*****	*****
0.850	-1.4474	-1.2732	-1.0797	-0.7470	-0.5589	*****	*****	*****	*****	*****
0.875	*****	-1.2189	-0.9061	-0.7654	-0.5366	*****	*****	*****	*****	*****
0.900	-1.2709	-1.1684	-0.8171	-0.7995	-0.5059	*****	*****	*****	*****	*****
0.925	*****	-1.1410	-0.8036	-0.8356	-0.4796	*****	*****	*****	*****	*****
0.950	-1.2520	-1.1573	-0.7906	-0.8623	-0.4367	*****	*****	*****	*****	*****
0.975	*****	-1.1096	-0.7517	-0.8245	-0.3993	*****	*****	*****	*****	*****
1.000	-1.4257	-1.2953	-0.7321	-0.9323	-0.4339	*****	*****	*****	*****	*****
-0.200	$C_{p,l}$	$C_{p,l}$	$C_{p,l}$	$C_{p,l}$	$C_{p,l}$	$C_{p,l}$	$C_{p,l}$	$C_{p,l}$	$C_{p,l}$	$C_{p,l}$
-0.400	0.4952	0.4438	0.4189	*****	*****	*****	*****	*****	*****	*****
-0.600	0.4933	0.4493	0.3941	0.1973	-0.6030	*****	*****	*****	*****	*****
-0.700	0.5043	0.4498	0.3896	0.2278	-0.5776	*****	*****	*****	*****	*****
-0.800	0.5018	0.4468	0.3874	0.2432	-0.5384	*****	*****	*****	*****	*****
-0.850	0.4796	*****	0.3812	0.2582	-0.4571	*****	*****	*****	*****	*****
-0.900	*****	0.4269	0.3723	0.2589	-0.4419	*****	*****	*****	*****	*****
-0.950	*****	0.3788	0.3410	0.2535	-0.3868	*****	*****	*****	*****	*****
-0.975	0.2123	0.2374	0.2228	0.1812	-0.1229	*****	*****	*****	*****	*****
-1.000	*****	0.0238	0.0401	0.0347	-0.0784	*****	*****	*****	*****	*****
	-1.3385	-1.1302	-1.0515	-1.0187	-0.4462	*****	*****	*****	*****	*****

Medium Radius L.E.
 Run No. = 13, Point No. = 280
 $C_N = 0.978$, $C_m = -0.1679$
 $\alpha = 20.5^\circ$, $M_\infty = 0.852$
 $R_{mac} = 48.3 \times 10^6$

Leading Edge Pressures

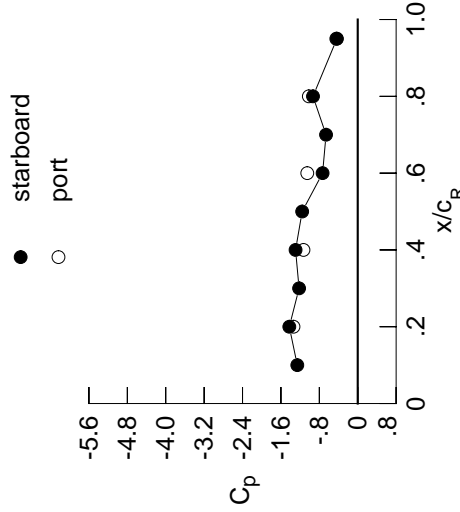

x/c_R	starb'd C_p	port C_p
0.10	-1.2592	*****
0.20	-1.4257	-1.3385
0.30	-1.2219	*****
0.40	-1.2953	-1.1302
0.50	-1.1575	*****
0.60	-0.7321	-1.0515
0.70	-0.6600	*****
0.80	-0.9323	-1.0187
0.90	-0.0030	*****
0.95	-0.4339	-0.4462

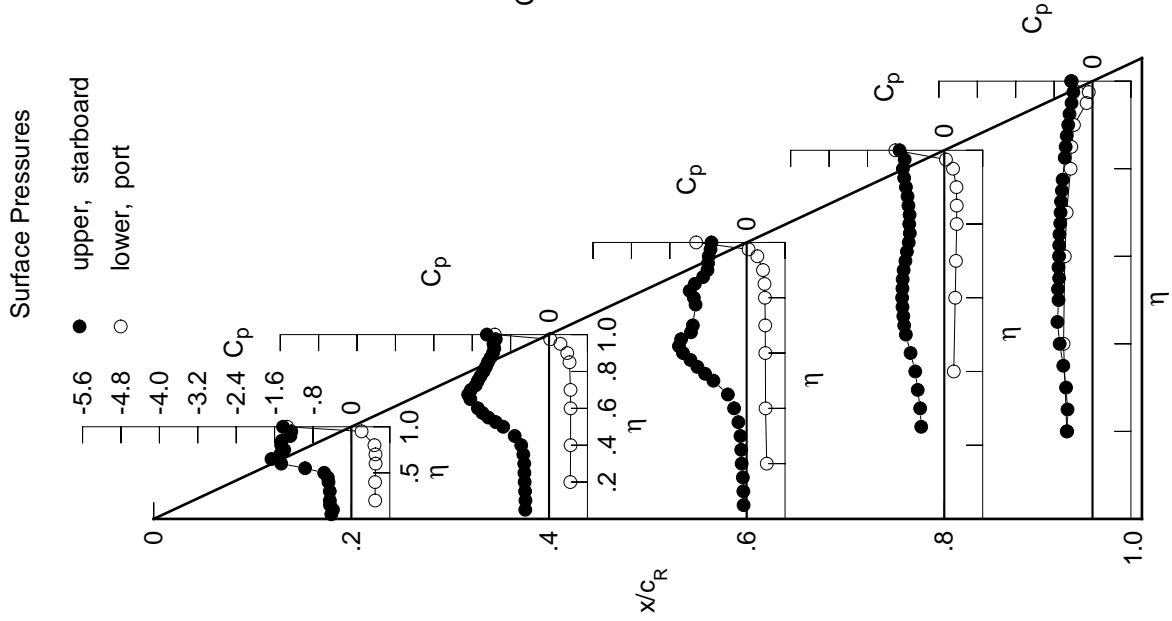
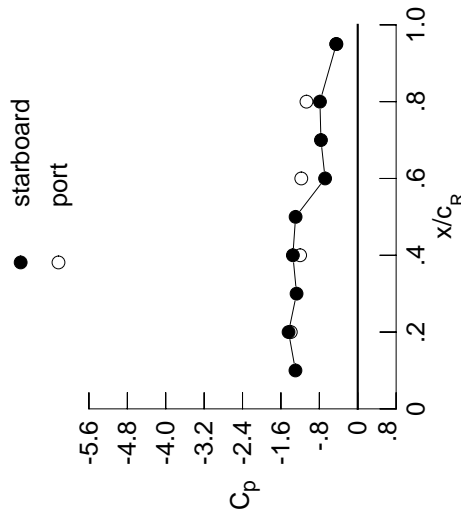

Table E5. Continued.

η	x/c_R .2	x/c_R .4	x/c_R .6	x/c_R .8	x/c_R .95
	$C_{p,u}$	$C_{p,u}$	$C_{p,u}$	$C_{p,u}$	$C_{p,u}$
0.050	-0.4936	-0.5770	-0.1137	*****	*****
0.100	-0.4534	-0.5727	-0.1157	*****	*****
0.150	-0.5261	-0.5677	-0.1202	*****	*****
0.200	-0.5257	-0.5904	-0.1266	*****	-0.5763
0.250	*****	-0.5952	-0.1505	-0.6833	-0.6223
0.300	-0.5342	-0.6196	-0.1884	-0.7126	-0.6773
0.350	*****	-0.6725	-0.2621	-0.7682	-0.7272
0.400	-0.5753	-0.7711	-0.3934	-0.8110	-0.7743
0.450	-0.6673	-0.9551	-0.5692	-0.8627	-0.7654
0.500	-0.9564	-1.1794	-0.9020	-0.8932	-0.7245
0.525	*****	-1.3003	-1.0601	-0.9020	-0.7382
0.550	-1.3977	-1.4283	-1.1887	-0.9011	-0.7218
0.575	*****	-1.5234	-1.3071	-0.9179	-0.7413
0.600	-1.6832	-1.6071	-1.4306	-0.9304	-0.7358
0.625	*****	*****	-1.3322	-0.9317	-0.7372
0.650	-1.8105	-1.5361	-1.1200	-0.9150	-0.7347
0.675	*****	-1.4925	-1.0569	-0.9003	-0.7181
0.700	-1.6652	-1.4693	-1.0245	-0.8784	-0.7106
0.725	*****	-1.4606	*****	-0.8596	-0.7010
0.750	-1.5253	-1.4539	*****	-0.8245	-0.6816
0.775	*****	-1.4645	-0.9856	-0.7994	-0.6640
0.800	-1.4247	-1.4997	-1.0042	-0.8039	*****
0.825	*****	-1.4556	-1.0203	-0.8004	-0.6137
0.850	-1.4170	-1.3483	-0.9307	-0.8048	-0.5936
0.875	*****	-1.2779	-0.8484	-0.7990	-0.5724
0.900	-1.3183	-1.2666	-0.7967	-0.7931	-0.5459
0.925	*****	-1.2628	-0.7711	-0.7822	-0.5260
0.950	-1.2862	-1.2942	-0.7487	-0.7788	-0.4784
0.975	*****	-1.2593	-0.7111	-0.7582	-0.4385
1.000	-1.4411	-1.3510	-0.6801	-0.7875	-0.4445
	$C_{p,l}$	$C_{p,l}$	$C_{p,l}$	$C_{p,l}$	$C_{p,l}$
-0.200	0.5531	0.4930	0.4577	*****	-0.5093
-0.400	0.5498	0.4965	0.4330	0.2300	-0.5801
-0.600	0.5559	0.4950	0.4277	0.2591	-0.5536
-0.700	0.5477	0.4890	0.4235	0.2725	-0.5127
-0.800	0.5125	*****	0.4117	0.2848	-0.4302
-0.850	*****	0.4525	0.3970	0.2817	-0.4142
-0.900	*****	0.3888	0.3531	0.2673	-0.3596
-0.950	0.1978	0.2231	0.2088	0.1726	-0.1146
-0.975	*****	-0.0135	0.0032	0.0034	-0.0920
-1.000	-1.3946	-1.2001	-1.1757	-1.0681	-0.4477

Medium Radius L.E.
 Run No. = 13, Point No. = 281
 $C_N = 1.081$, $C_m = -0.1827$
 $\alpha = 22.6^\circ$, $M_\infty = 0.849$
 $R_{mac} = 48.1 \times 10^6$

Leading Edge Pressures



x/c_R	starb'd C_p	port C_p
0.10	-1.2973	*****
0.20	-1.4411	-1.3946
0.30	-1.2744	*****
0.40	-1.3510	-1.2001
0.50	-1.2946	*****
0.60	-0.6801	-1.1757
0.70	-0.7664	*****
0.80	-0.7875	-1.0681
0.90	-0.0058	*****
0.95	-0.4445	-0.4477

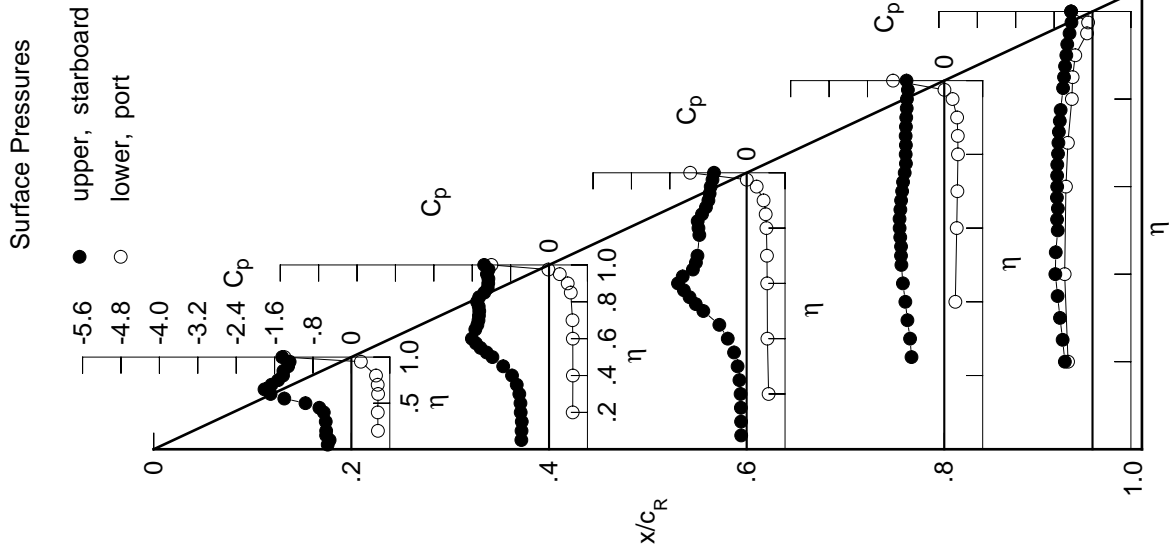

Table E5. Continued.

η	$x/c_R = .2$		$x/c_R = .4$		$x/c_R = .6$		$x/c_R = .8$		$x/c_R = .95$	
	$C_{p,u}$	$C_{p,u}$	$C_{p,u}$	$C_{p,u}$	$C_{p,u}$	$C_{p,u}$	$C_{p,u}$	$C_{p,u}$	$C_{p,u}$	$C_{p,u}$
0.050	-0.5820	-0.6427	0.0141	*****	*****	*****	*****	*****	*****	*****
0.100	-0.5419	-0.6431	0.0020	*****	*****	*****	*****	*****	*****	*****
0.150	-0.5887	-0.6475	-0.0171	*****	*****	*****	*****	*****	*****	*****
0.200	-0.6092	-0.6566	-0.0390	*****	*****	*****	*****	*****	*****	*****
0.250	*****	-0.6900	-0.0832	-0.8129	-0.8129	-0.6044	*****	*****	*****	*****
0.300	-0.6469	-0.7381	-0.1492	-0.8543	-0.6730	*****	*****	*****	*****	*****
0.350	*****	-0.8259	-0.2651	-0.9095	-0.7402	*****	*****	*****	*****	*****
0.400	-0.7664	-0.9565	-0.4518	-0.9568	-0.8314	*****	*****	*****	*****	*****
0.450	-0.9801	-1.1446	-0.6796	-0.9990	-0.8570	*****	*****	*****	*****	*****
0.500	-1.3107	-1.3340	-0.9855	-0.9972	-0.8038	*****	*****	*****	*****	*****
0.525	*****	-1.4308	-1.1233	-0.9879	-0.7990	*****	*****	*****	*****	*****
0.550	-1.5934	-1.5372	-1.2407	-0.9541	-0.7679	*****	*****	*****	*****	*****
0.575	-1.6110	-1.6767	-1.4389	-0.9578	-0.7677	*****	*****	*****	*****	*****
0.600	-1.7611	-1.6767	-1.4389	-0.9578	-0.7677	*****	*****	*****	*****	*****
0.625	*****	*****	-1.3625	-0.9678	-0.7725	*****	*****	*****	*****	*****
0.650	-1.6891	-1.5396	-1.1735	-0.9623	-0.7693	*****	*****	*****	*****	*****
0.675	*****	-1.4726	-1.1039	-0.9473	-0.7529	*****	*****	*****	*****	*****
0.700	-1.6849	-1.4665	-1.0590	-0.9255	-0.7432	*****	*****	*****	*****	*****
0.725	*****	-1.4671	*****	-0.9184	-0.7336	*****	*****	*****	*****	*****
0.750	-1.6529	-1.4613	*****	-0.8949	-0.7143	*****	*****	*****	*****	*****
0.775	*****	-1.4974	-0.9625	-0.8723	-0.6980	*****	*****	*****	*****	*****
0.800	-1.4172	-1.5200	-0.9408	-0.8785	*****	*****	*****	*****	*****	*****
0.825	*****	-1.4603	-0.9499	-0.8737	-0.6503	*****	*****	*****	*****	*****
0.850	-1.4283	-1.3917	-0.8965	-0.8750	-0.6307	*****	*****	*****	*****	*****
0.875	*****	-1.3586	-0.8374	-0.8642	-0.6068	*****	*****	*****	*****	*****
0.900	-1.3561	-1.3555	-0.7772	-0.8502	-0.5800	*****	*****	*****	*****	*****
0.925	*****	-1.3625	-0.7370	-0.8288	-0.5679	*****	*****	*****	*****	*****
0.950	-1.3412	-1.3764	-0.7074	-0.8151	-0.5182	*****	*****	*****	*****	*****
0.975	*****	-1.3500	-0.6846	-0.7968	-0.4766	*****	*****	*****	*****	*****
1.000	-1.4479	-1.4021	-0.6496	-0.7996	-0.4639	*****	*****	*****	*****	*****
-0.200	$C_{p,l}$	$C_{p,l}$	$C_{p,l}$	$C_{p,l}$	$C_{p,l}$	$C_{p,l}$	$C_{p,l}$	$C_{p,l}$	$C_{p,l}$	$C_{p,l}$
-0.400	0.6092	0.5410	0.4967	*****	-0.4984	*****	*****	*****	*****	*****
-0.600	0.6053	0.5450	0.4673	0.2613	-0.5666	*****	*****	*****	*****	*****
-0.700	0.6058	0.5400	0.4674	0.2891	-0.5411	*****	*****	*****	*****	*****
-0.800	0.5902	0.5310	0.4642	0.2998	-0.5030	*****	*****	*****	*****	*****
-0.850	0.5429	*****	0.4500	0.3105	-0.4233	*****	*****	*****	*****	*****
-0.900	*****	0.4775	0.4325	0.3045	-0.4124	*****	*****	*****	*****	*****
-0.950	0.1831	0.2115	0.2296	0.1821	-0.1356	*****	*****	*****	*****	*****
-0.975	*****	-0.0456	0.0215	0.0093	-0.1332	*****	*****	*****	*****	*****
-1.000	-1.4218	-1.3186	-0.6346	-0.8146	-0.5246	*****	*****	*****	*****	*****

Medium Radius L.E.
 Run No. = 13, Point No. = 282
 $C_N = 1.125$, $C_m = -0.1836$
 $\alpha = 24.6^\circ$, $M_\infty = 0.849$
 $R_{mac} = 47.7 \times 10^6$

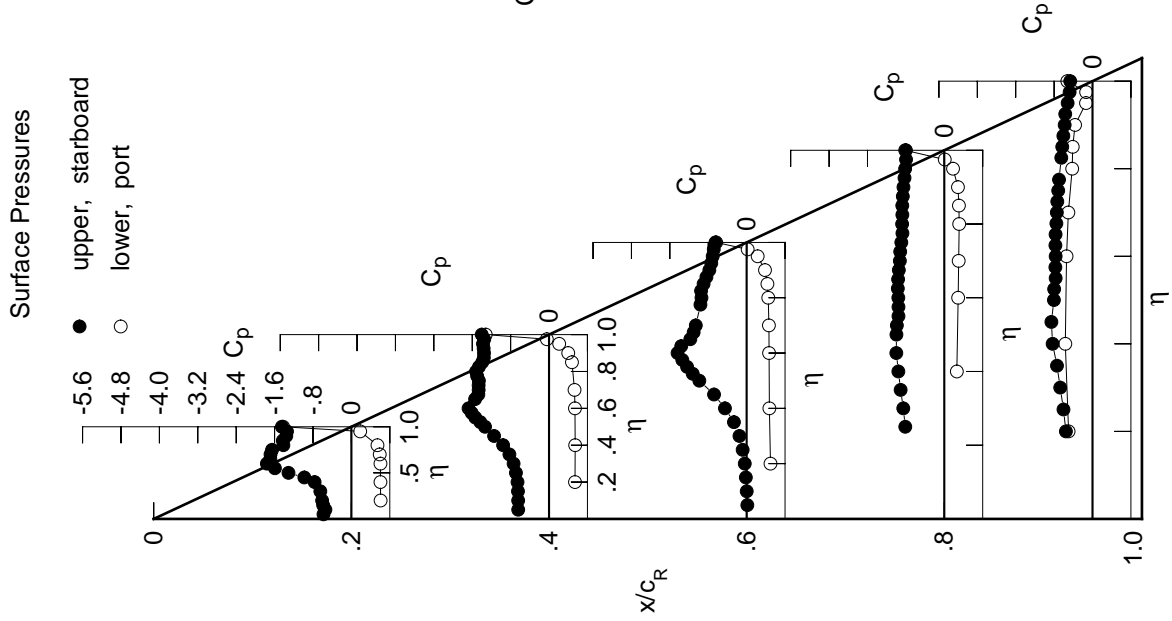
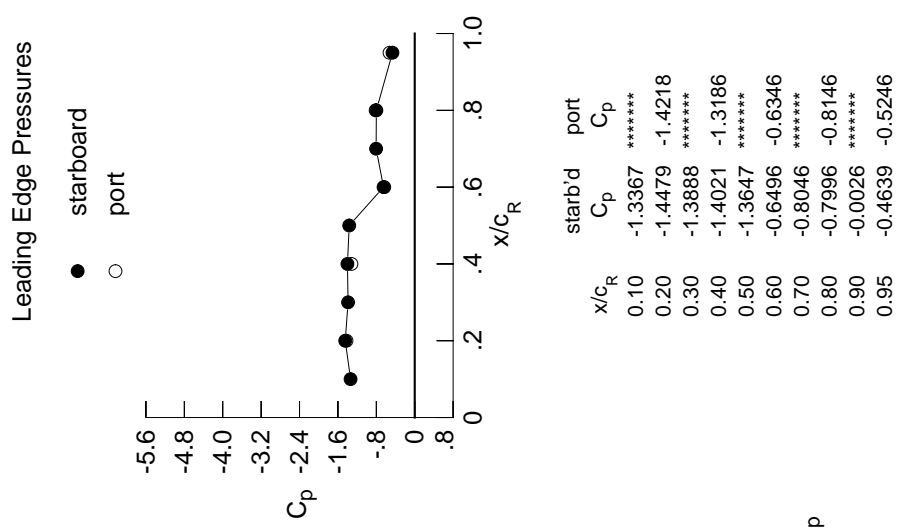

Table E5. Concluded.

η	$x/c_R = .2$		$x/c_R = .4$		$x/c_R = .6$		$x/c_R = .8$		$x/c_R = .95$	
	$C_{p,u}$	$C_{p,u}$	$C_{p,u}$	$C_{p,u}$	$C_{p,u}$	$C_{p,u}$	$C_{p,u}$	$C_{p,u}$	$C_{p,u}$	$C_{p,u}$
0.050	-0.6700	-0.7254	-0.1702	*****	*****	*****	*****	*****	*****	*****
0.100	-0.6406	-0.7354	-0.1646	*****	*****	*****	*****	*****	*****	*****
0.150	-0.6811	-0.7501	-0.1633	*****	*****	*****	*****	*****	*****	*****
0.200	-0.6977	-0.7713	-0.1740	*****	*****	*****	*****	*****	*****	-0.6649
0.250	*****	-0.8148	-0.2108	-1.0528	-0.7536	*****	*****	*****	*****	-0.7536
0.300	-0.7606	-0.8745	-0.2847	-1.0735	-0.8432	*****	*****	*****	*****	-0.8432
0.350	*****	-0.9727	-0.4043	-1.0778	-0.8845	*****	*****	*****	*****	-0.8845
0.400	-1.0157	-1.1181	-0.5899	-1.0544	-0.8716	*****	*****	*****	*****	-0.8716
0.450	-1.2766	-1.3006	-0.8042	-1.0158	-0.8022	*****	*****	*****	*****	-0.8022
0.500	-1.5316	-1.4587	-1.0659	-0.9513	-0.7508	*****	*****	*****	*****	-0.7508
0.525	*****	-1.5373	-1.1764	-0.9423	-0.7696	*****	*****	*****	*****	-0.7696
0.550	-1.7088	-1.6234	-1.2674	-0.9330	-0.7651	*****	*****	*****	*****	-0.7651
0.575	*****	-1.6782	-1.3366	-0.9598	-0.7891	*****	*****	*****	*****	-0.7891
0.600	-1.7804	-1.6960	-1.3771	-0.9940	-0.7913	*****	*****	*****	*****	-0.7913
0.625	*****	*****	-1.2414	-1.0101	-0.8022	*****	*****	*****	*****	-0.8022
0.650	-1.6592	-1.5455	-1.0822	-1.0133	-0.7999	*****	*****	*****	*****	-0.7999
0.675	*****	-1.5153	-1.0257	-1.0180	-0.7820	*****	*****	*****	*****	-0.7820
0.700	-1.6843	-1.5073	-0.9913	-1.0093	-0.7753	*****	*****	*****	*****	-0.7753
0.725	*****	-1.5138	*****	-1.0011	-0.7654	*****	*****	*****	*****	-0.7654
0.750	-1.6974	-1.5225	*****	-0.9721	-0.7485	*****	*****	*****	*****	-0.7485
0.775	*****	-1.5606	-0.9202	-0.9484	-0.7339	*****	*****	*****	*****	-0.7339
0.800	-1.4577	-1.5731	-0.8839	-0.9504	*****	*****	*****	*****	*****	*****
0.825	*****	-1.5197	-0.8556	-0.9415	-0.6822	*****	*****	*****	*****	-0.6822
0.850	-1.4594	-1.4564	-0.8187	-0.9324	-0.6637	*****	*****	*****	*****	-0.6637
0.875	*****	-1.4207	-0.8057	-0.9142	-0.6411	*****	*****	*****	*****	-0.6411
0.900	-1.4071	-1.4190	-0.7879	-0.8958	-0.6153	*****	*****	*****	*****	-0.6153
0.925	*****	-1.4315	-0.7651	-0.8716	-0.5987	*****	*****	*****	*****	-0.5987
0.950	-1.4139	-1.4310	-0.7508	-0.8634	-0.5548	*****	*****	*****	*****	-0.5548
0.975	*****	-1.4174	-0.7478	-0.8260	-0.5128	*****	*****	*****	*****	-0.5128
1.000	-1.4873	-1.4522	-0.7142	-0.8085	-0.4835	*****	*****	*****	*****	-0.4835
-0.200	$C_{p,l}$	$C_{p,l}$	$C_{p,l}$	$C_{p,l}$	$C_{p,l}$	$C_{p,l}$	$C_{p,l}$	$C_{p,l}$	$C_{p,l}$	$C_{p,l}$
-0.400	0.6569	0.5817	0.5265	*****	*****	*****	*****	*****	*****	-0.4805
-0.600	0.6544	0.5850	0.5041	0.2883	0.5440	*****	*****	*****	*****	-0.5440
-0.700	0.6491	0.5761	0.4971	0.3145	-0.5193	*****	*****	*****	*****	-0.5193
-0.800	0.6262	0.5671	0.4911	0.3209	-0.4815	*****	*****	*****	*****	-0.4815
-0.850	0.5671	*****	0.4730	0.3300	-0.4026	*****	*****	*****	*****	-0.4026
-0.900	*****	0.4958	0.4495	0.3257	-0.3881	*****	*****	*****	*****	-0.3881
-0.950	*****	0.4044	0.3874	0.2992	-0.3397	*****	*****	*****	*****	-0.3397
-0.975	0.1622	0.1957	0.2095	0.1785	-0.1297	*****	*****	*****	*****	-0.1297
-1.000	*****	-0.0809	-0.0190	-0.0100	-0.1450	*****	*****	*****	*****	-0.1450
-1.000	-1.4600	-1.3918	-0.8819	-0.7005	-0.5262	*****	*****	*****	*****	-0.5262

Medium Radius L.E.
 Run No. = 13, Point No. = 283
 $C_N = 1.203$, $C_m = -0.1938$
 $\alpha = 26.7^\circ$, $M_\infty = 0.849$
 $R_{mac} = 47.2 \times 10^6$

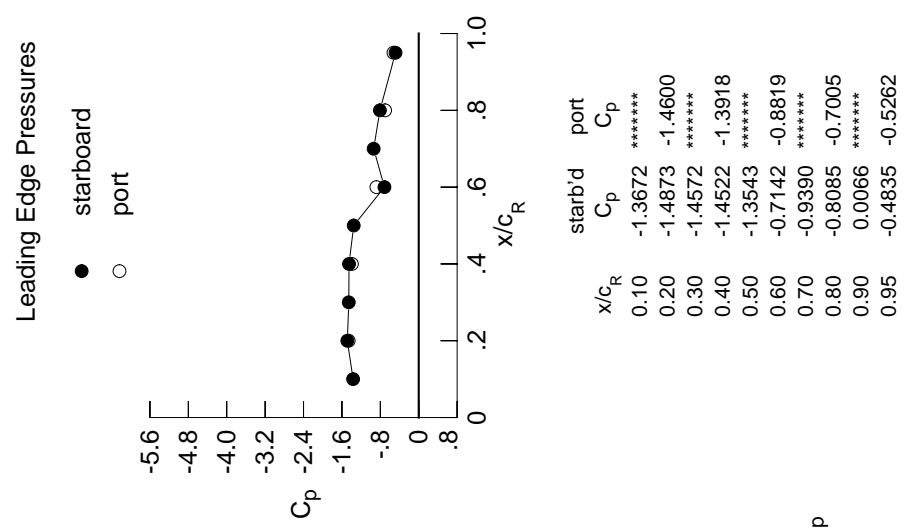

Table E6. Tabulations and Plots of Surface Pressure Coefficients.

η	$x/c_R = .2$		$x/c_R = .4$		$x/c_R = .6$		$x/c_R = .8$		$x/c_R = .95$	
	$C_{p,u}$	$C_{p,u}$	$C_{p,u}$	$C_{p,u}$	$C_{p,u}$	$C_{p,u}$	$C_{p,u}$	$C_{p,u}$	$C_{p,u}$	$C_{p,u}$
0.050	0.0082	0.0198	0.1447	0.1447	0.1447	0.1447	0.1447	0.1447	0.1447	0.1447
0.100	0.0182	0.0204	0.1330	0.1330	0.1330	0.1330	0.1330	0.1330	0.1330	0.1330
0.150	0.0069	0.0214	0.1209	0.1209	0.1209	0.1209	0.1209	0.1209	0.1209	0.1209
0.200	0.0062	0.0249	0.1091	0.1091	0.1091	0.1091	0.1091	0.1091	0.1091	0.1091
0.250	0.0000	0.0200	0.0965	0.0965	0.0965	0.0965	0.0965	0.0965	0.0965	0.0965
0.300	-0.0026	0.0204	0.0859	0.0859	0.0859	0.0859	0.0859	0.0859	0.0859	0.0859
0.350	0.0000	0.0177	0.0769	0.0769	0.0769	0.0769	0.0769	0.0769	0.0769	0.0769
0.400	-0.0165	0.0177	0.0693	0.0693	0.0693	0.0693	0.0693	0.0693	0.0693	0.0693
0.450	-0.0206	0.0144	0.0773	0.0773	0.0773	0.0773	0.0773	0.0773	0.0773	0.0773
0.500	-0.0250	0.0164	0.0527	0.0677	0.0677	0.0677	0.0677	0.0677	0.0677	0.0677
0.525	0.0000	0.0115	0.0508	0.0668	0.0668	0.0668	0.0668	0.0668	0.0668	0.0668
0.550	-0.0262	0.0061	0.0481	0.0616	0.0616	0.0616	0.0616	0.0616	0.0616	0.0616
0.575	0.0000	0.0046	0.0530	0.0621	0.0621	0.0621	0.0621	0.0621	0.0621	0.0621
0.600	-0.0317	0.0020	0.0386	0.0609	0.0609	0.0609	0.0609	0.0609	0.0609	0.0609
0.625	0.0000	0.0000	0.0408	0.0570	0.0570	0.0570	0.0570	0.0570	0.0570	0.0570
0.650	-0.0302	0.0014	0.0354	0.0559	0.0559	0.0559	0.0559	0.0559	0.0559	0.0559
0.675	0.0000	-0.0106	0.0280	0.0569	0.0569	0.0569	0.0569	0.0569	0.0569	0.0569
0.700	-0.0242	-0.0161	0.0267	0.0565	0.0565	0.0565	0.0565	0.0565	0.0565	0.0565
0.725	0.0000	-0.0231	0.0000	0.0544	0.0544	0.0544	0.0544	0.0544	0.0544	0.0544
0.750	-0.0152	-0.0289	0.0061	0.0534	0.0534	0.0534	0.0534	0.0534	0.0534	0.0534
0.775	0.0000	-0.0319	0.0000	0.0509	0.0509	0.0509	0.0509	0.0509	0.0509	0.0509
0.800	0.0053	-0.0332	0.0050	0.0620	0.0620	0.0620	0.0620	0.0620	0.0620	0.0620
0.825	0.0000	-0.0319	0.0148	0.0592	0.0592	0.0592	0.0592	0.0592	0.0592	0.0592
0.850	0.0276	-0.0262	0.0235	0.0777	0.0777	0.0777	0.0777	0.0777	0.0777	0.0777
0.875	0.0000	-0.0151	0.0263	0.0849	0.0849	0.0849	0.0849	0.0849	0.0849	0.0849
0.900	0.0625	-0.0029	0.0227	0.0904	0.0904	0.0904	0.0904	0.0904	0.0904	0.0904
0.925	0.0000	0.0214	0.0075	0.0820	0.0820	0.0820	0.0820	0.0820	0.0820	0.0820
0.950	0.1139	0.0596	0.0253	0.0511	0.0511	0.0511	0.0511	0.0511	0.0511	0.0511
0.975	0.0000	0.1151	0.0819	0.0122	0.0122	0.0122	0.0122	0.0122	0.0122	0.0122
1.000	0.2166	0.2067	0.1727	0.1429	0.1429	0.1429	0.1429	0.1429	0.1429	0.1429
	$C_{p,l}$	$C_{p,l}$	$C_{p,l}$	$C_{p,l}$	$C_{p,l}$	$C_{p,l}$	$C_{p,l}$	$C_{p,l}$	$C_{p,l}$	$C_{p,l}$
-0.200	-0.0302	-0.0055	0.0783	0.0555	0.0555	0.0555	0.0555	0.0555	0.0555	0.0555
-0.400	-0.0569	-0.0067	0.0380	0.1057	0.1057	0.1057	0.1057	0.1057	0.1057	0.1057
-0.600	-0.0821	-0.0339	0.0088	0.0861	0.0861	0.0861	0.0861	0.0861	0.0861	0.0861
-0.700	-0.0852	-0.0706	0.0184	0.0896	0.0896	0.0896	0.0896	0.0896	0.0896	0.0896
-0.800	-0.0719	0.0000	-0.0653	0.1034	0.1034	0.1034	0.1034	0.1034	0.1034	0.1034
-0.850	0.0000	-0.1088	0.1011	0.1352	0.1352	0.1352	0.1352	0.1352	0.1352	0.1352
-0.900	0.0000	-0.0992	0.1200	0.1763	0.1763	0.1763	0.1763	0.1763	0.1763	0.1763
-0.950	0.0263	-0.0527	0.0925	0.1705	0.1705	0.1705	0.1705	0.1705	0.1705	0.1705
-0.975	0.0000	-0.0016	0.0460	0.1207	0.1207	0.1207	0.1207	0.1207	0.1207	0.1207
-1.000	0.1896	0.1754	0.1364	0.1234	0.1234	0.1234	0.1234	0.1234	0.1234	0.1234

Medium Radius L.E.
 Run No. = 14, Point No. = 284
 $C_N = -0.023$, $C_m = -0.0057$
 $\alpha = -0.9^\circ$, $M_\infty = 0.852$
 $R_{mac} = 60.8 \times 10^6$

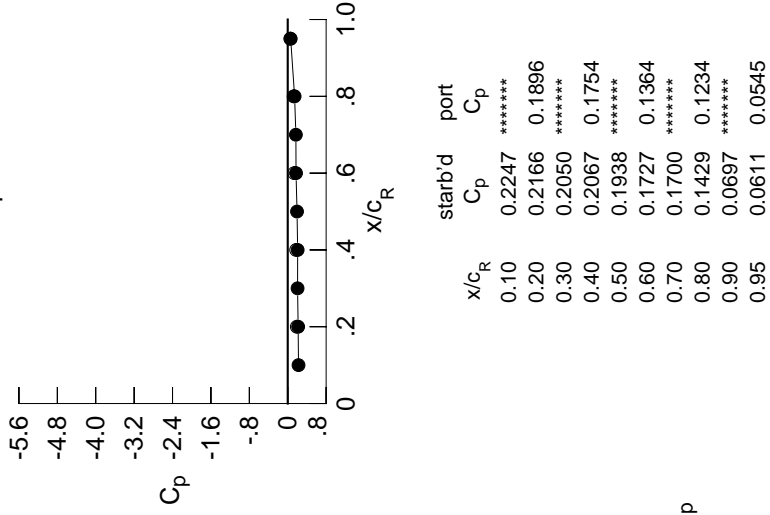
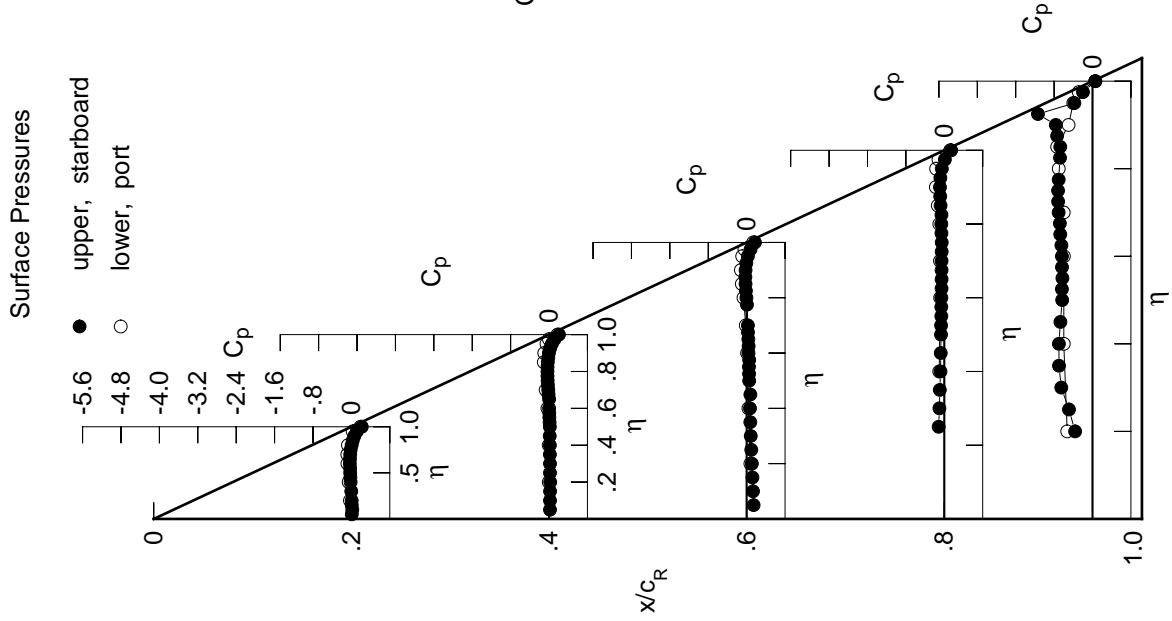
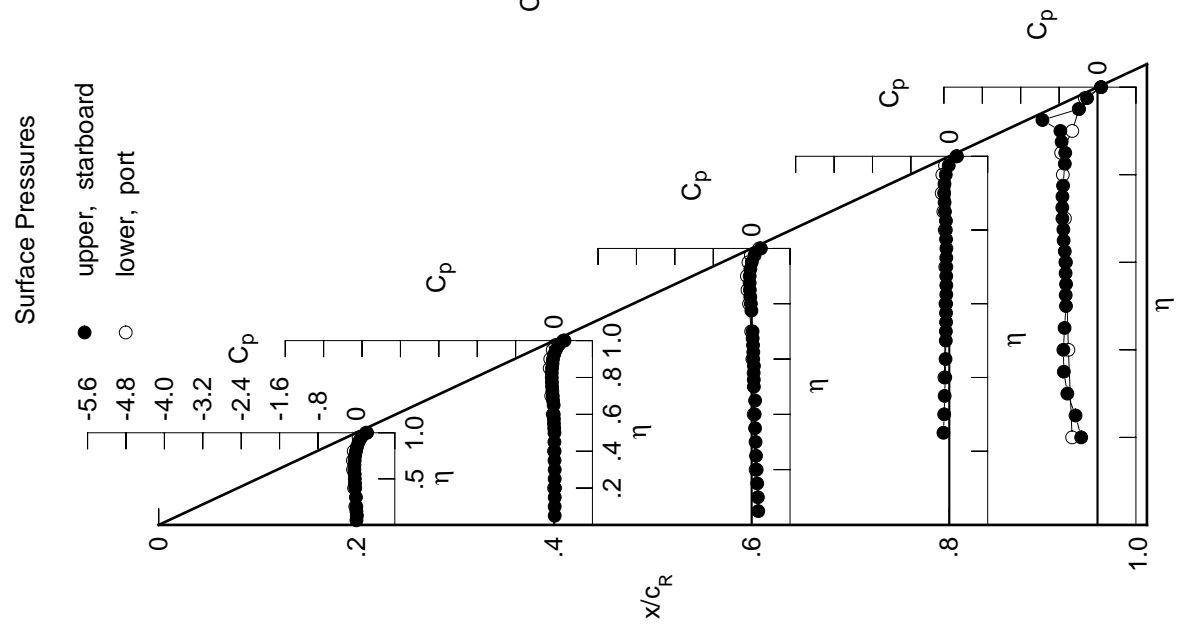

Table E6. Continued.

η	x/c_R .2	x/c_R .4	x/c_R .6	x/c_R .8	x/c_R .95
	$C_{p,u}$	$C_{p,u}$	$C_{p,u}$	$C_{p,u}$	$C_{p,u}$
0.050	0.0013	0.0140	0.1383	*****	*****
0.100	0.0112	0.0139	0.1298	*****	*****
0.150	-0.0002	0.0147	0.1159	*****	*****
0.200	-0.0013	0.0191	0.1049	*****	-0.3396
0.250	*****	0.0132	0.0913	-0.1216	-0.4578
0.300	-0.0095	0.0143	0.0813	-0.1067	-0.6284
0.350	*****	0.0106	0.0712	-0.0971	-0.7018
0.400	-0.0237	0.0108	0.0633	-0.0841	-0.7111
0.450	-0.0293	0.0077	0.0719	-0.0784	-0.6866
0.500	-0.0339	0.0086	0.0461	-0.0725	-0.6571
0.525	*****	0.0041	0.0448	-0.0716	-0.6635
0.550	-0.0352	-0.0021	0.0417	-0.0669	-0.6550
0.575	*****	-0.0032	0.0473	-0.0677	-0.6651
0.600	-0.0420	-0.0064	0.0326	-0.0675	-0.6692
0.625	*****	*****	0.0342	-0.0624	-0.6820
0.650	-0.0412	-0.0082	0.0285	-0.0623	-0.7055
0.675	*****	-0.0205	0.0206	-0.0635	-0.7111
0.700	-0.0363	-0.0264	0.0193	-0.0625	-0.7314
0.725	*****	-0.0348	*****	-0.0620	-0.7339
0.750	-0.0279	-0.0404	*****	-0.0606	-0.7301
0.775	*****	-0.0449	-0.0046	-0.0674	-0.7175
0.800	-0.0080	-0.0471	-0.0162	-0.0718	*****
0.825	*****	-0.0470	-0.0280	-0.0693	-0.6817
0.850	0.0138	-0.0423	-0.0374	-0.0903	-0.6724
0.875	*****	-0.0319	-0.0418	-0.0987	-0.7484
0.900	0.0482	-0.0215	-0.0410	-0.1076	-0.7737
0.925	*****	0.0017	-0.0272	-0.1003	-1.1471
0.950	0.0989	0.0403	0.0034	-0.0738	-0.3908
0.975	*****	0.0952	0.0597	-0.0115	-0.2173
1.000	0.2230	0.2178	0.1928	0.1603	0.0750
	$C_{p,l}$	$C_{p,l}$	$C_{p,l}$	$C_{p,l}$	$C_{p,l}$
-0.200	-0.0226	0.0010	0.0833	*****	-0.5291
-0.400	-0.0479	0.0004	0.0428	-0.1014	-0.6069
-0.600	-0.0703	-0.0254	0.0160	-0.0798	-0.6582
-0.700	-0.0722	-0.0593	-0.0098	-0.0829	-0.6782
-0.800	-0.0559	*****	-0.0534	-0.0935	-0.7224
-0.850	*****	-0.0906	-0.0856	-0.1230	-0.7572
-0.900	*****	-0.0782	-0.0995	-0.1583	-0.5258
-0.950	0.0463	-0.0278	-0.0663	-0.1450	-0.3862
-0.975	*****	0.0258	-0.0161	-0.0900	-0.2649
-1.000	0.1982	0.1910	0.1581	0.1489	0.0722

Medium Radius L.E.
 Run No. = 14 , Point No. = 285
 $C_N = -0.008$, $C_m = -0.0083$
 $\alpha = -0.5^\circ$, $M_\infty = 0.850$
 $R_{mac} = 60.6 \times 10^6$



Leading Edge Pressures

● starboard
 ○ port

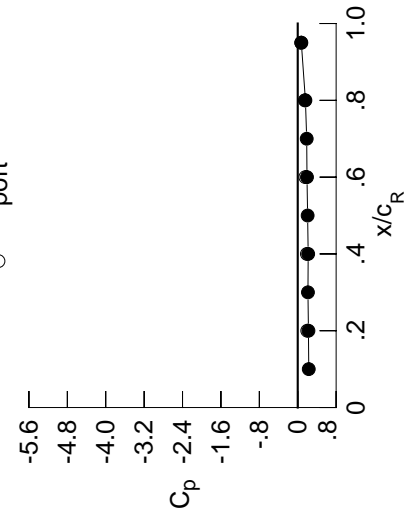

x/c_R	starb'd C_p	port C_p
0.10	0.2299	*****
0.20	0.2230	0.1982
0.30	0.2129	*****
0.40	0.2178	0.1910
0.50	0.2061	*****
0.60	0.1928	0.1581
0.70	0.1869	*****
0.80	0.1603	0.1489
0.90	0.0773	*****
0.95	0.0750	0.0722

Table E6. Continued.

η	$x/c_R = .2$		$x/c_R = .4$		$x/c_R = .6$		$x/c_R = .8$		$x/c_R = .95$	
	$C_{p,u}$	$C_{p,u}$	$C_{p,u}$	$C_{p,u}$	$C_{p,u}$	$C_{p,u}$	$C_{p,u}$	$C_{p,u}$	$C_{p,u}$	$C_{p,u}$
0.050	-0.0185	-0.0042	0.1270	*****	*****	*****	*****	*****	*****	*****
0.100	-0.0083	-0.0040	0.1161	*****	*****	*****	*****	*****	*****	*****
0.150	-0.0198	-0.0034	0.1027	*****	*****	*****	*****	*****	*****	*****
0.200	-0.0214	0.0006	0.0915	*****	*****	*****	*****	*****	*****	*****
0.250	*****	-0.0052	0.0777	-0.1336	-0.1336	-0.1336	-0.1336	-0.1336	-0.1336	-0.1336
0.300	-0.0297	-0.0047	0.0676	-0.1192	-0.1192	-0.1192	-0.1192	-0.1192	-0.1192	-0.1192
0.350	*****	-0.0085	0.0560	-0.1097	-0.1097	-0.1097	-0.1097	-0.1097	-0.1097	-0.1097
0.400	-0.0470	-0.0090	0.0489	-0.0970	-0.0970	-0.0970	-0.0970	-0.0970	-0.0970	-0.0970
0.450	-0.0533	-0.0127	0.0563	-0.0916	-0.0916	-0.0916	-0.0916	-0.0916	-0.0916	-0.0916
0.500	-0.0596	-0.0128	0.0303	-0.0858	-0.0858	-0.0858	-0.0858	-0.0858	-0.0858	-0.0858
0.525	*****	-0.0185	0.0276	-0.0857	-0.0857	-0.0857	-0.0857	-0.0857	-0.0857	-0.0857
0.550	-0.0634	-0.0250	0.0245	-0.0819	-0.0819	-0.0819	-0.0819	-0.0819	-0.0819	-0.0819
0.575	*****	-0.0273	0.0287	-0.0842	-0.0842	-0.0842	-0.0842	-0.0842	-0.0842	-0.0842
0.600	-0.0715	-0.0309	0.0133	-0.0829	-0.0829	-0.0829	-0.0829	-0.0829	-0.0829	-0.0829
0.625	*****	*****	0.0146	-0.0784	-0.0784	-0.0784	-0.0784	-0.0784	-0.0784	-0.0784
0.650	-0.0738	-0.0342	0.0086	-0.0785	-0.0785	-0.0785	-0.0785	-0.0785	-0.0785	-0.0785
0.675	*****	-0.0478	-0.0005	-0.0813	-0.0813	-0.0813	-0.0813	-0.0813	-0.0813	-0.0813
0.700	-0.0712	-0.0562	-0.0034	-0.0808	-0.0808	-0.0808	-0.0808	-0.0808	-0.0808	-0.0808
0.725	*****	-0.0664	*****	-0.0816	-0.0816	-0.0816	-0.0816	-0.0816	-0.0816	-0.0816
0.750	-0.0647	-0.0748	*****	-0.0815	-0.0815	-0.0815	-0.0815	-0.0815	-0.0815	-0.0815
0.775	*****	-0.0819	-0.0323	-0.0905	-0.0905	-0.0905	-0.0905	-0.0905	-0.0905	-0.0905
0.800	-0.0471	-0.0869	-0.0482	-0.0974	-0.0974	-0.0974	-0.0974	-0.0974	-0.0974	-0.0974
0.825	*****	-0.0895	-0.0635	-0.0964	-0.0964	-0.0964	-0.0964	-0.0964	-0.0964	-0.0964
0.850	-0.0276	-0.0882	-0.0787	-0.1217	-0.1217	-0.1217	-0.1217	-0.1217	-0.1217	-0.1217
0.875	*****	-0.0820	-0.0881	-0.1376	-0.1376	-0.1376	-0.1376	-0.1376	-0.1376	-0.1376
0.900	0.0039	-0.0747	-0.0928	-0.1532	-0.1532	-0.1532	-0.1532	-0.1532	-0.1532	-0.1532
0.925	*****	-0.0554	-0.0851	-0.1552	-0.1552	-0.1552	-0.1552	-0.1552	-0.1552	-0.1552
0.950	0.0524	-0.0202	-0.0617	-0.1364	-0.1364	-0.1364	-0.1364	-0.1364	-0.1364	-0.1364
0.975	*****	0.0313	-0.0100	-0.0832	-0.0832	-0.0832	-0.0832	-0.0832	-0.0832	-0.0832
1.000	0.2220	0.2171	0.2015	0.1582	0.1582	0.1582	0.1582	0.1582	0.1582	0.1582
$C_{p,l}$	$C_{p,l}$	$C_{p,l}$	$C_{p,l}$	$C_{p,l}$	$C_{p,l}$	$C_{p,l}$	$C_{p,l}$	$C_{p,l}$	$C_{p,l}$	$C_{p,l}$
-0.200	-0.0030	0.0197	0.0962	*****	*****	*****	*****	*****	*****	*****
-0.400	-0.0250	0.0194	0.0585	-0.0888	-0.0888	-0.0888	-0.0888	-0.0888	-0.0888	-0.0888
-0.600	-0.0409	-0.0017	0.0342	-0.0652	-0.0652	-0.0652	-0.0652	-0.0652	-0.0652	-0.0652
-0.700	-0.0379	-0.0297	0.0124	-0.0642	-0.0642	-0.0642	-0.0642	-0.0642	-0.0642	-0.0642
-0.800	-0.0164	*****	-0.0214	-0.0689	-0.0689	-0.0689	-0.0689	-0.0689	-0.0689	-0.0689
-0.850	*****	-0.0449	-0.0449	-0.0898	-0.0898	-0.0898	-0.0898	-0.0898	-0.0898	-0.0898
-0.900	*****	-0.0249	-0.0478	-0.1111	-0.1111	-0.1111	-0.1111	-0.1111	-0.1111	-0.1111
-0.950	0.0946	0.0326	-0.0025	-0.0805	-0.0805	-0.0805	-0.0805	-0.0805	-0.0805	-0.0805
-0.975	*****	0.0899	0.0562	-0.0165	-0.0165	-0.0165	-0.0165	-0.0165	-0.0165	-0.0165
-1.000	0.2036	0.1991	0.1703	0.1676	0.1676	0.1676	0.1676	0.1676	0.1676	0.1676

Medium Radius L.E.
 Run No. = 14, Point No. = 286
 $C_N = 0.033$, $C_m = -0.0148$
 $\alpha = 0.5^\circ$, $M_\infty = 0.850$
 $R_{mac} = 60.6 \times 10^6$

Leading Edge Pressures

● starboard
 ○ port

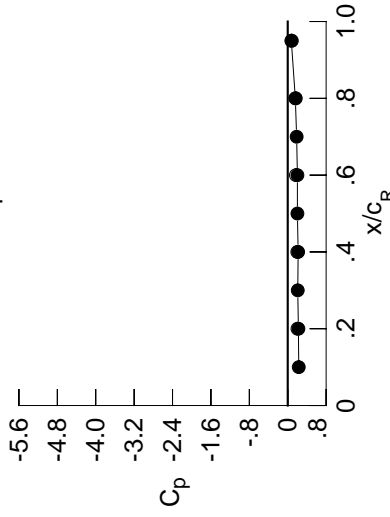

x/c_R	starb'd C_p	port C_p
0.10	0.2298	*****
0.20	0.2220	0.2036
0.30	0.2089	*****
0.40	0.2171	0.1991
0.50	0.2014	*****
0.60	0.2015	0.1703
0.70	0.1855	*****
0.80	0.1582	0.1676
0.90	0.0767	*****
0.95	0.0748	0.0846

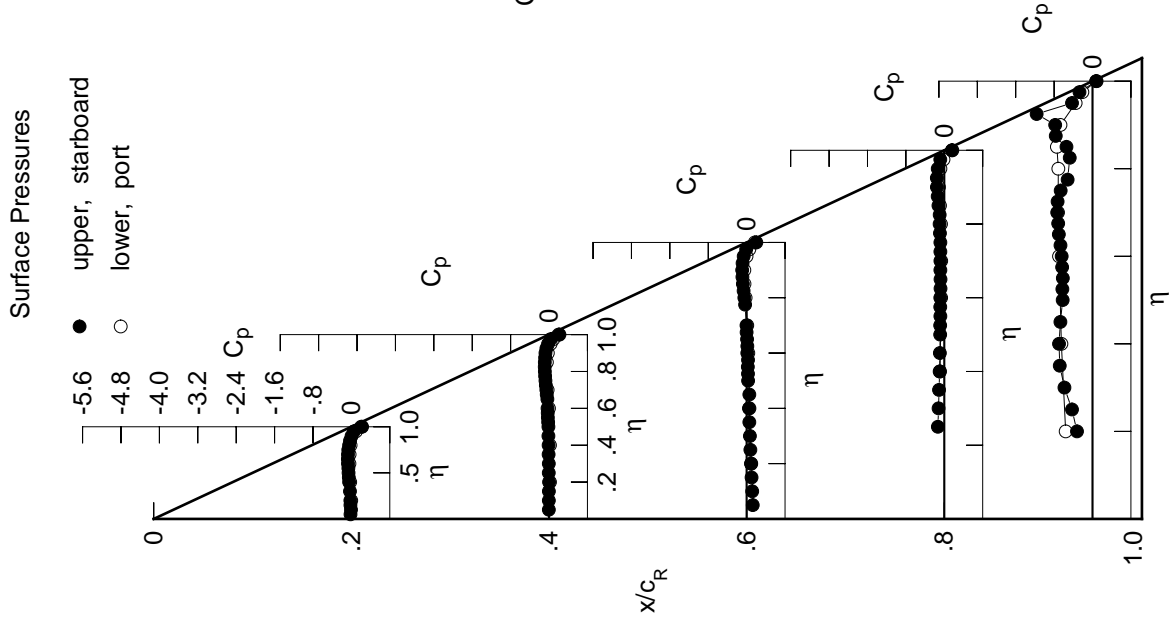

Table E6. Continued.

Medium Radius L.E.
 Run No. = 14 , Point No. = 287
 $C_N = 0.073$, $C_m = -0.0203$
 $\alpha = 1.6^\circ$, $M_\infty = 0.852$
 $R_{mac} = 60.6 \times 10^6$

η	$x/c_R = .2$		$x/c_R = .4$		$x/c_R = .6$		$x/c_R = .8$		$x/c_R = .95$	
	$C_{p,u}$	$C_{p,u}$	$C_{p,u}$	$C_{p,u}$	$C_{p,u}$	$C_{p,u}$	$C_{p,u}$	$C_{p,u}$	$C_{p,u}$	$C_{p,u}$
0.050	-0.0400	-0.0223	0.1140	*****	*****	*****	*****	*****	*****	*****
0.100	-0.0287	-0.0216	0.1040	*****	*****	*****	*****	*****	*****	*****
0.150	-0.0409	-0.0211	0.0906	*****	*****	*****	*****	*****	*****	*****
0.200	-0.0418	-0.0185	0.0781	*****	0.0644	-0.1477	-0.4154	*****	-0.3128	*****
0.250	*****	-0.0241	0.0644	-0.1477	-0.4154	*****	*****	*****	*****	*****
0.300	-0.0507	-0.0237	0.0535	-0.1329	-0.5721	*****	*****	*****	*****	*****
0.350	*****	-0.0280	0.0419	-0.1226	-0.6896	*****	*****	*****	*****	*****
0.400	-0.0705	-0.0291	0.0336	-0.1105	-0.7120	*****	*****	*****	*****	*****
0.450	-0.0790	-0.0338	0.0411	-0.1056	-0.6870	*****	*****	*****	*****	*****
0.500	-0.0866	-0.0342	0.0133	-0.1005	-0.6448	*****	*****	*****	*****	*****
0.525	*****	-0.0408	0.0105	-0.1004	-0.6478	*****	*****	*****	*****	*****
0.550	-0.0922	-0.0479	0.0067	-0.0972	-0.6400	*****	*****	*****	*****	*****
0.575	*****	-0.0513	0.0107	-0.0997	-0.6543	*****	*****	*****	*****	*****
0.600	-0.1026	-0.0561	-0.0052	-0.0985	-0.6686	*****	*****	*****	*****	*****
0.625	*****	*****	-0.0048	-0.0962	-0.6970	*****	*****	*****	*****	*****
0.650	-0.1071	-0.0615	-0.0124	-0.0967	-0.7288	*****	*****	*****	*****	*****
0.675	*****	-0.0770	-0.0226	-0.1001	-0.7350	*****	*****	*****	*****	*****
0.700	-0.1077	-0.0874	-0.0267	-0.1010	-0.7413	*****	*****	*****	*****	*****
0.725	*****	-0.0996	*****	-0.1029	-0.6973	*****	*****	*****	*****	*****
0.750	-0.1036	-0.1103	*****	-0.1047	-0.5557	*****	*****	*****	*****	*****
0.775	*****	-0.1206	-0.0616	-0.1165	-0.3912	*****	*****	*****	*****	*****
0.800	-0.0893	-0.1297	-0.0811	-0.1256	*****	*****	*****	*****	*****	*****
0.825	*****	-0.1358	-0.1016	-0.1255	-0.3895	*****	*****	*****	*****	*****
0.850	-0.0730	-0.1385	-0.1217	-0.1574	-0.4467	*****	*****	*****	*****	*****
0.875	*****	-0.1366	-0.1377	-0.1791	-0.7449	*****	*****	*****	*****	*****
0.900	-0.0458	-0.1326	-0.1497	-0.2042	-0.7199	*****	*****	*****	*****	*****
0.925	*****	-0.1199	-0.1498	-0.2158	-1.1629	*****	*****	*****	*****	*****
0.950	-0.0024	-0.0894	-0.1360	-0.2097	-0.4683	*****	*****	*****	*****	*****
0.975	*****	-0.0473	-0.0956	-0.1702	-0.3362	*****	*****	*****	*****	*****
1.000	0.1956	0.1690	0.1336	0.0851	0.0183	*****	*****	*****	*****	*****

x/c_R	starb'd C_p	port C_p
0.10	0.2136	*****
0.20	0.1956	0.1792
0.30	0.1692	*****
0.40	0.1690	0.1615
0.50	0.1340	*****
0.60	0.1336	0.1148
0.70	0.1139	*****
0.80	0.0851	0.1119
0.90	0.0719	*****
0.95	0.0183	0.0449

Surface Pressures
 ● upper, starboard
 ○ lower, port

Leading Edge Pressures
 ● starboard
 ○ port

Table E6. Continued.

η	$x/c_R = .2$		$x/c_R = .4$		$x/c_R = .6$		$x/c_R = .8$		$x/c_R = .95$	
	$C_{p,u}$	$C_{p,u}$	$C_{p,u}$	$C_{p,u}$	$C_{p,u}$	$C_{p,u}$	$C_{p,u}$	$C_{p,u}$	$C_{p,u}$	$C_{p,u}$
0.050	-0.0580	-0.0395	0.1021	*****	*****	*****	*****	*****	*****	
0.100	-0.0478	-0.0392	0.0915	*****	*****	*****	*****	*****	*****	
0.150	-0.0601	-0.0393	0.0778	*****	*****	*****	*****	*****	*****	
0.200	-0.0618	-0.0357	0.0664	*****	*****	*****	*****	*****	-0.3176	
0.250	*****	-0.0418	0.0513	-0.1601	-0.1405	-0.1453	-0.5375	*****	*****	
0.300	-0.0714	-0.0422	0.0405	-0.1453	-0.1453	-0.5375	*****	*****	*****	
0.350	*****	-0.0470	0.0278	-0.1350	-0.6681	*****	*****	*****	*****	
0.400	-0.0935	-0.0476	0.0190	-0.1237	-0.7058	*****	*****	*****	*****	
0.450	-0.1035	-0.0542	0.0249	-0.1188	-0.6860	*****	*****	*****	*****	
0.500	-0.1130	-0.0556	-0.0026	-0.1150	-0.6470	*****	*****	*****	*****	
0.525	*****	-0.0626	-0.0063	-0.1154	-0.6509	*****	*****	*****	*****	
0.550	-0.1216	-0.0718	-0.0106	-0.1125	-0.6456	*****	*****	*****	*****	
0.575	*****	-0.0754	-0.0076	-0.1149	-0.6653	*****	*****	*****	*****	
0.600	-0.1339	-0.0807	-0.0249	-0.1156	-0.6854	*****	*****	*****	*****	
0.625	*****	*****	-0.0248	-0.1130	-0.7125	*****	*****	*****	*****	
0.650	-0.1410	-0.0889	-0.0337	-0.1144	-0.7331	*****	*****	*****	*****	
0.675	*****	-0.1055	-0.0450	-0.1191	-0.7152	*****	*****	*****	*****	
0.700	-0.1447	-0.1188	-0.0503	-0.1208	-0.6507	*****	*****	*****	*****	
0.725	*****	-0.1336	*****	-0.1248	-0.5164	*****	*****	*****	*****	
0.750	-0.1444	-0.1474	*****	-0.1284	-0.3753	*****	*****	*****	*****	
0.775	*****	-0.1612	-0.0934	-0.1427	-0.2524	*****	*****	*****	*****	
0.800	-0.1339	-0.1735	-0.1164	-0.1540	*****	*****	*****	*****	*****	
0.825	*****	-0.1848	-0.1418	-0.1565	-0.2774	*****	*****	*****	*****	
0.850	-0.1218	-0.1921	-0.1687	-0.1941	-0.3253	*****	*****	*****	*****	
0.875	*****	-0.1957	-0.1922	-0.2245	-0.5439	*****	*****	*****	*****	
0.900	-0.1005	-0.1973	-0.2128	-0.2598	-0.6754	*****	*****	*****	*****	
0.925	*****	-0.1914	-0.2230	-0.2831	-1.1293	*****	*****	*****	*****	
0.950	-0.0645	-0.1687	-0.2209	-0.2912	-0.5152	*****	*****	*****	*****	
0.975	*****	-0.1406	-0.1975	-0.2731	-0.4124	*****	*****	*****	*****	
1.000	0.1396	0.0667	0.0075	-0.0629	-0.0917	*****	*****	*****	*****	
-0.200	$C_{p,l}$	$C_{p,l}$	$C_{p,l}$	$C_{p,l}$	$C_{p,l}$	$C_{p,l}$	$C_{p,l}$	$C_{p,l}$	$C_{p,l}$	
-0.400	0.0381	0.0548	0.1223	*****	-0.6253	*****	*****	*****	*****	
-0.600	0.0214	0.0572	0.0879	-0.0633	-0.7059	*****	*****	*****	*****	
-0.700	0.0167	0.0451	0.0699	-0.0347	-0.7254	*****	*****	*****	*****	
-0.800	0.0278	0.0266	0.0556	-0.0288	-0.7224	*****	*****	*****	*****	
-0.850	0.0571	*****	0.0373	-0.0217	-0.6784	*****	*****	*****	*****	
-0.900	*****	0.0384	0.0296	-0.0291	-0.6959	*****	*****	*****	*****	
-0.950	*****	0.0676	0.0436	-0.0277	-0.7357	*****	*****	*****	*****	
-0.975	0.1701	0.1274	0.1002	0.0257	-0.2912	*****	*****	*****	*****	
-1.000	0.1245	0.0695	-0.0213	-0.0174	-0.0450	*****	*****	*****	*****	

Medium Radius L.E.
 Run No. = 14 , Point No. = 288
 $C_N = 0.115$, $C_m = -0.0272$
 $\alpha = 2.7^\circ$, $M_\infty = 0.851$
 $R_{mac} = 60.6 \times 10^6$

Leading Edge Pressures

● starboard
 ○ port

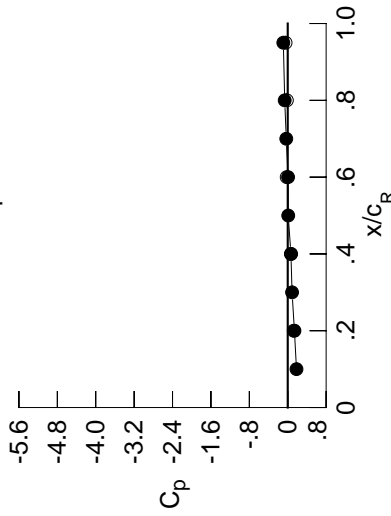

x/c_R	starb'd C_p	port C_p
0.10	0.1822	*****
0.20	0.1396	0.1245
0.30	0.0903	*****
0.40	0.0667	0.0695
0.50	0.0100	*****
0.60	0.0075	-0.0213
0.70	-0.0303	*****
0.80	-0.0629	-0.0174
0.90	0.0585	*****
0.95	-0.0917	-0.0450

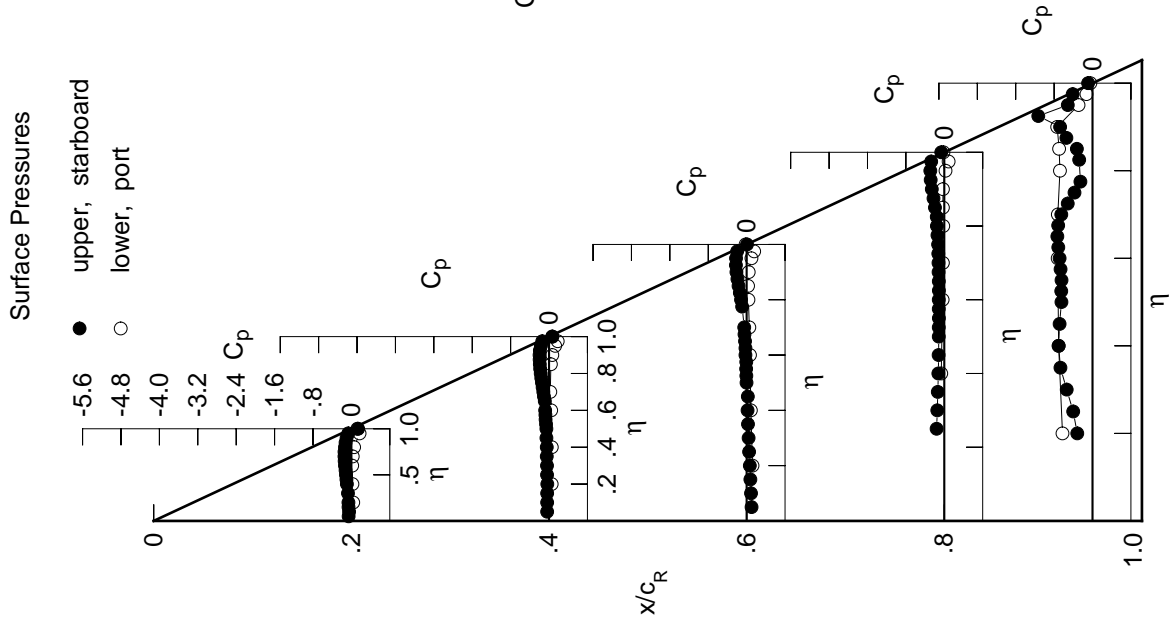
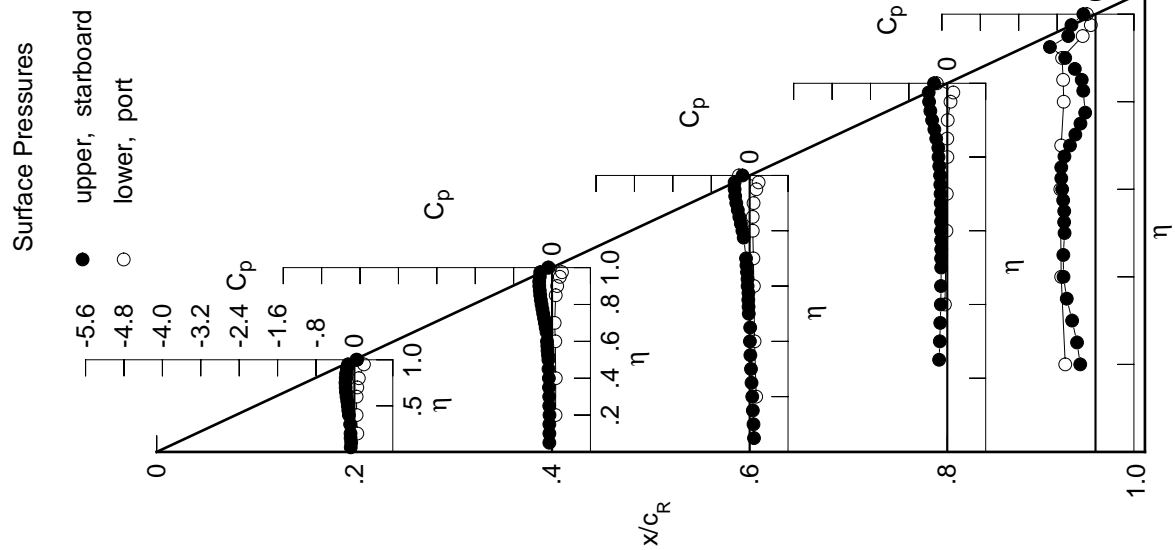

Table E6. Continued.

η	x/c_R .2	x/c_R .4	x/c_R .6	x/c_R .8	x/c_R .95
	$C_{p,u}$	$C_{p,u}$	$C_{p,u}$	$C_{p,u}$	$C_{p,u}$
0.050	-0.0757	-0.0556	0.0906	*****	*****
0.100	-0.0664	-0.0553	0.0803	*****	*****
0.150	-0.0782	-0.0558	0.0662	*****	*****
0.200	-0.0804	-0.0526	0.0543	*****	-0.3183
0.250	*****	-0.0581	0.0391	-0.1708	-0.3849
0.300	-0.0892	-0.0590	0.0281	-0.1555	-0.4873
0.350	*****	-0.0636	0.0149	-0.1461	-0.5992
0.400	-0.1147	-0.0662	0.0054	-0.1350	-0.6670
0.450	-0.1267	-0.0734	0.0112	-0.1308	-0.6706
0.500	-0.1378	-0.0756	-0.0186	-0.1274	-0.6452
0.525	*****	-0.0844	-0.0226	-0.1287	-0.6538
0.550	-0.1490	-0.0933	-0.0279	-0.1262	-0.6521
0.575	*****	-0.0981	-0.0256	-0.1288	-0.6737
0.600	-0.1641	-0.1049	-0.0428	-0.1309	-0.6949
0.625	*****	*****	-0.0442	-0.1290	-0.7130
0.650	-0.1757	-0.1147	-0.0540	-0.1307	-0.7137
0.675	*****	-0.1327	-0.0664	-0.1372	-0.6469
0.700	-0.1819	-0.1490	-0.0749	-0.1401	-0.5320
0.725	*****	-0.1662	*****	-0.1453	-0.4198
0.750	-0.1852	-0.1838	*****	-0.1506	-0.3140
0.775	*****	-0.2011	-0.1238	-0.1668	-0.2155
0.800	-0.1801	-0.2183	-0.1508	-0.1822	*****
0.825	*****	-0.2333	-0.1816	-0.1869	-0.2553
0.850	-0.1735	-0.2465	-0.2151	-0.2305	-0.2870
0.875	*****	-0.2555	-0.2465	-0.2696	-0.4313
0.900	-0.1579	-0.2652	-0.2786	-0.3164	-0.6308
0.925	*****	-0.2674	-0.3005	-0.3528	-0.9493
0.950	-0.1339	-0.2550	-0.3131	-0.3794	-0.5692
0.975	*****	-0.2465	-0.3126	-0.3879	-0.5018
1.000	0.0555	-0.0843	-0.1482	-0.2760	-0.2535
	$C_{p,l}$	$C_{p,l}$	$C_{p,l}$	$C_{p,l}$	$C_{p,l}$
-0.200	0.0606	0.0732	0.1362	*****	-0.6302
-0.400	0.0458	0.0774	0.1028	-0.0493	-0.7153
-0.600	0.0459	0.0678	0.0883	-0.0178	-0.7327
-0.700	0.0602	0.0546	0.0778	-0.0104	-0.7145
-0.800	0.0919	*****	0.0651	0.0015	-0.6622
-0.850	*****	0.0764	0.0630	-0.0007	-0.6743
-0.900	*****	0.1074	0.0817	0.0089	-0.6959
-0.950	0.1988	0.1633	0.1389	0.0670	-0.2672
-0.975	*****	0.2067	0.1866	0.1255	-0.0974
-1.000	0.0403	-0.0668	-0.2233	-0.2178	-0.1791



Medium Radius L.E.
 Run No. = 14, Point No. = 289
 $C_N = 0.158$, $C_m = -0.0354$
 $\alpha = 3.7^\circ$, $M_\infty = 0.851$
 $R_{mac} = 60.6 \times 10^6$

Leading Edge Pressures

● starboard
 ○ port

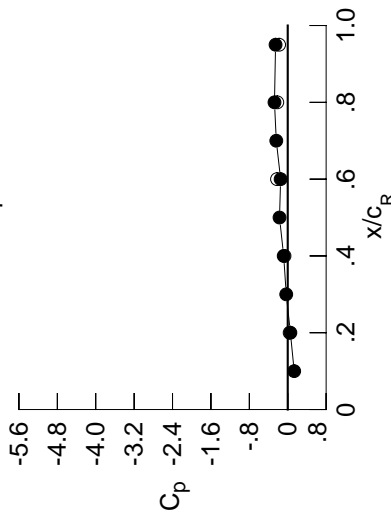

x/c_R	starb'd C_p	port C_p
0.10	0.1344	*****
0.20	0.0555	0.0403
0.30	-0.0309	*****
0.40	-0.0843	-0.0668
0.50	-0.1711	*****
0.60	-0.1482	-0.2233
0.70	-0.2385	*****
0.80	-0.2760	-0.2178
0.90	0.0360	*****
0.95	-0.2535	-0.1791

Table E6. Continued.

η	$x/c_R = .2$		$x/c_R = .4$		$x/c_R = .6$		$x/c_R = .8$		$x/c_R = .95$	
	$C_{p,u}$	$C_{p,u}$	$C_{p,u}$	$C_{p,u}$	$C_{p,u}$	$C_{p,u}$	$C_{p,u}$	$C_{p,u}$	$C_{p,u}$	$C_{p,u}$
0.050	-0.0935	-0.0723	0.0791	0.0791	0.0791	0.0791	0.0791	0.0791	0.0791	0.0791
0.100	-0.0847	-0.0712	0.0693	0.0693	0.0693	0.0693	0.0693	0.0693	0.0693	0.0693
0.150	-0.0977	-0.0729	0.0544	0.0544	0.0544	0.0544	0.0544	0.0544	0.0544	0.0544
0.200	-0.0993	-0.0689	0.0432	0.0432	0.0432	0.0432	0.0432	0.0432	0.0432	0.0432
0.250	*****	-0.0754	0.0271	0.0271	0.0271	0.0271	0.0271	0.0271	0.0271	0.0271
0.300	-0.1093	-0.0765	0.0149	0.0149	0.0149	0.0149	0.0149	0.0149	0.0149	0.0149
0.350	*****	-0.0836	0.0010	0.0010	0.0010	0.0010	0.0010	0.0010	0.0010	0.0010
0.400	-0.1365	-0.0856	-0.0091	-0.0091	-0.0091	-0.0091	-0.0091	-0.0091	-0.0091	-0.0091
0.450	-0.1505	-0.0935	-0.0045	-0.0045	-0.0045	-0.0045	-0.0045	-0.0045	-0.0045	-0.0045
0.500	-0.1637	-0.0972	-0.0335	-0.0335	-0.0335	-0.0335	-0.0335	-0.0335	-0.0335	-0.0335
0.525	*****	-0.1075	-0.0395	-0.0395	-0.0395	-0.0395	-0.0395	-0.0395	-0.0395	-0.0395
0.550	-0.1771	-0.1163	-0.0454	-0.0454	-0.0454	-0.0454	-0.0454	-0.0454	-0.0454	-0.0454
0.575	*****	-0.1225	-0.0439	-0.0439	-0.0439	-0.0439	-0.0439	-0.0439	-0.0439	-0.0439
0.600	-0.1951	-0.1309	-0.0620	-0.0620	-0.0620	-0.0620	-0.0620	-0.0620	-0.0620	-0.0620
0.625	*****	*****	-0.0639	-0.0639	-0.0639	-0.0639	-0.0639	-0.0639	-0.0639	-0.0639
0.650	-0.2102	-0.1427	-0.0753	-0.0753	-0.0753	-0.0753	-0.0753	-0.0753	-0.0753	-0.0753
0.675	*****	-0.1633	-0.0878	-0.0878	-0.0878	-0.0878	-0.0878	-0.0878	-0.0878	-0.0878
0.700	-0.2203	-0.1818	-0.0982	-0.0982	-0.0982	-0.0982	-0.0982	-0.0982	-0.0982	-0.0982
0.725	*****	-0.2021	*****	-0.1676	-0.1676	-0.1676	-0.1676	-0.1676	-0.1676	-0.1676
0.750	-0.2277	-0.2222	*****	-0.1749	-0.1749	-0.1749	-0.1749	-0.1749	-0.1749	-0.1749
0.775	*****	-0.2436	-0.1558	-0.1558	-0.1558	-0.1558	-0.1558	-0.1558	-0.1558	-0.1558
0.800	-0.2273	-0.2655	-0.1878	-0.1878	-0.1878	-0.1878	-0.1878	-0.1878	-0.1878	-0.1878
0.825	*****	-0.2865	-0.2233	-0.2233	-0.2233	-0.2233	-0.2233	-0.2233	-0.2233	-0.2233
0.850	-0.2267	-0.3056	-0.2649	-0.2649	-0.2649	-0.2649	-0.2649	-0.2649	-0.2649	-0.2649
0.875	*****	-0.3217	-0.3056	-0.3172	-0.3172	-0.3172	-0.3172	-0.3172	-0.3172	-0.3172
0.900	-0.2196	-0.3384	-0.3486	-0.3486	-0.3486	-0.3486	-0.3486	-0.3486	-0.3486	-0.3486
0.925	*****	-0.3511	-0.3852	-0.4295	-0.4295	-0.4295	-0.4295	-0.4295	-0.4295	-0.4295
0.950	-0.2086	-0.3523	-0.4171	-0.4171	-0.4171	-0.4171	-0.4171	-0.4171	-0.4171	-0.4171
0.975	*****	-0.3663	-0.4418	-0.5201	-0.5201	-0.5201	-0.5201	-0.5201	-0.5201	-0.5201
1.000	-0.0582	-0.2739	-0.3524	-0.5650	-0.5650	-0.5650	-0.5650	-0.5650	-0.5650	-0.5650
-0.200	$C_{p,l}$	0.0809	0.0923	0.1511	0.1511	0.1511	0.1511	0.1511	0.1511	0.1511
-0.400	0.0691	0.0963	0.1185	0.0357	-0.7266	0.1185	0.0357	-0.7266	0.1185	0.0357
-0.600	0.0740	0.0904	0.1075	0.0035	-0.7275	0.1075	0.0035	-0.7275	0.1075	0.0035
-0.700	0.0903	0.0807	0.0990	0.0065	-0.7035	0.0990	0.0065	-0.7035	0.0990	0.0065
-0.800	0.1235	*****	0.0913	0.0220	-0.6476	0.0913	0.0220	-0.6476	0.0913	0.0220
-0.850	*****	0.1099	0.0933	0.0244	-0.6549	0.0933	0.0244	-0.6549	0.0933	0.0244
-0.900	*****	0.1416	0.1155	0.0397	-0.6635	0.1155	0.0397	-0.6635	0.1155	0.0397
-0.950	0.2203	0.1911	0.1692	0.0982	-0.2485	0.1692	0.0982	-0.2485	0.1692	0.0982
-0.975	*****	0.2196	0.2043	0.1466	-0.0774	0.2043	0.1466	-0.0774	0.2043	0.1466
-1.000	-0.0702	-0.2393	-0.4924	-0.4807	-0.3660	-0.4924	-0.4807	-0.3660	-0.4924	-0.4807

Medium Radius L.E.
 Run No. = 14 , Point No. = 290
 $C_N = 0.199$, $C_m = -0.0412$
 $\alpha = 4.8^\circ$, $M_\infty = 0.851$
 $R_{mac} = 60.6 \times 10^6$

Leading Edge Pressures

● starboard
 ○ port

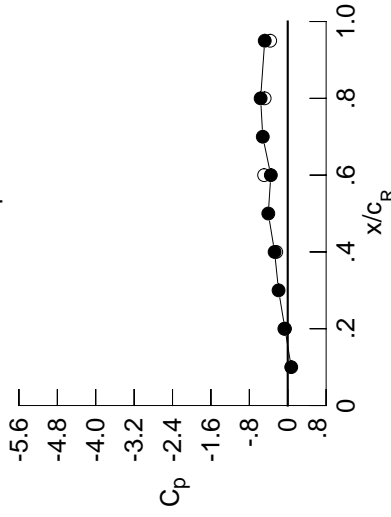

x/c_R	starb'd C_p	port C_p
0.10	0.0731	*****
0.20	-0.0582	-0.0702
0.30	-0.1910	*****
0.40	-0.2739	-0.2393
0.50	-0.4048	*****
0.60	-0.3524	-0.4924
0.70	-0.5199	*****
0.80	-0.5650	-0.4807
0.90	0.0081	*****
0.95	-0.4793	-0.3660

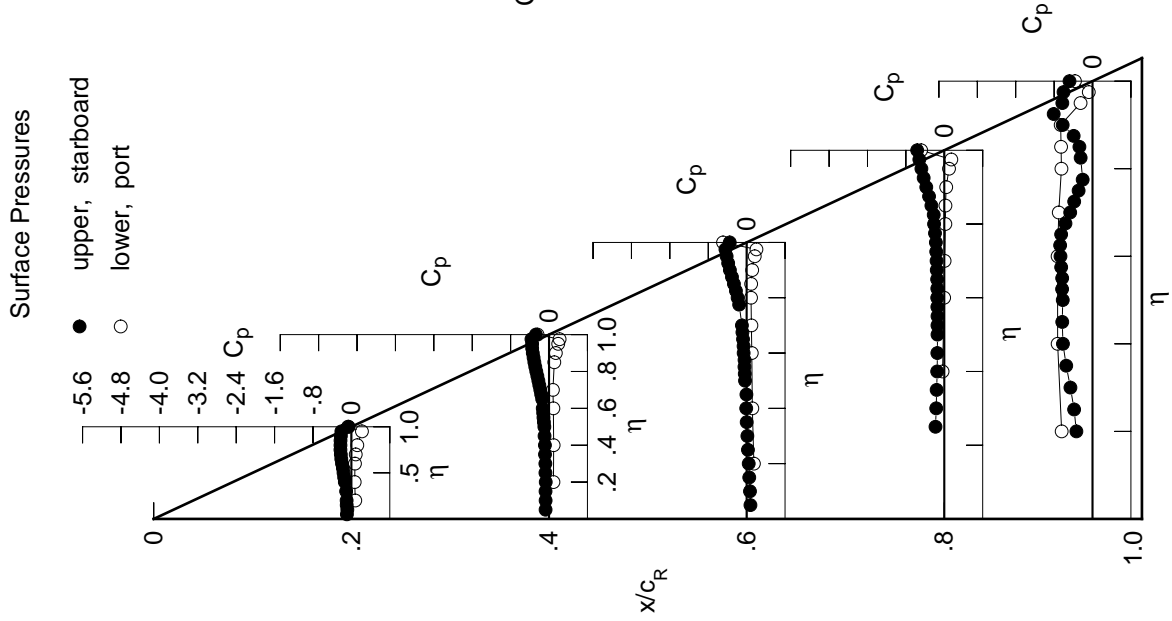
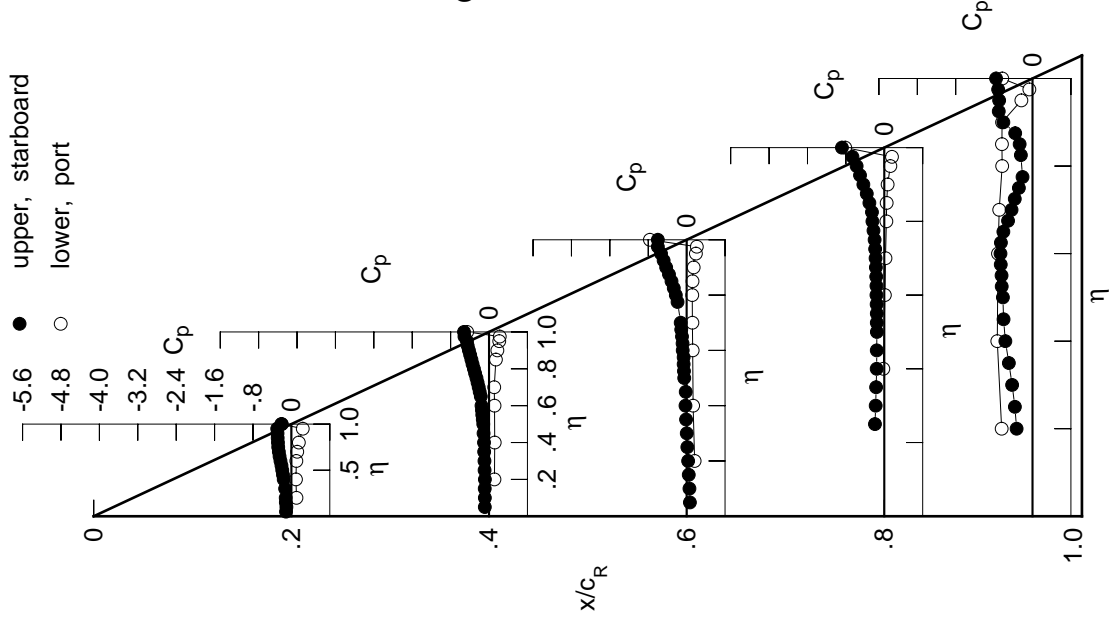

Table E6. Continued.

η	x/c_R .2	x/c_R .4	x/c_R .6	x/c_R .8	x/c_R .95
	$C_{p,u}$	$C_{p,u}$	$C_{p,u}$	$C_{p,u}$	$C_{p,u}$
0.050	-0.1123	-0.0881	0.0680	*****	*****
0.100	-0.1038	-0.0873	0.0581	*****	*****
0.150	-0.1159	-0.0893	0.0437	*****	*****
0.200	-0.1187	-0.0862	0.0310	*****	-0.3313
0.250	*****	-0.0925	0.0143	-0.1941	-0.3673
0.300	-0.1306	-0.0948	0.0027	-0.1789	-0.4244
0.350	*****	-0.1019	-0.0119	-0.1701	-0.4925
0.400	-0.1597	-0.1045	-0.0237	-0.1587	-0.5655
0.450	-0.1753	-0.1143	-0.0189	-0.1569	-0.6029
0.500	-0.1907	-0.1199	-0.0501	-0.1548	-0.6170
0.525	*****	-0.1305	-0.0560	-0.1563	-0.6416
0.550	-0.2067	-0.1406	-0.0623	-0.1561	-0.6448
0.575	*****	-0.1472	-0.0622	-0.1595	-0.6619
0.600	-0.2276	-0.1572	-0.0817	-0.1633	-0.6668
0.625	*****	*****	-0.0847	-0.1632	-0.6587
0.650	-0.2464	-0.1714	-0.0967	-0.1678	-0.6070
0.675	*****	-0.1947	-0.1126	-0.1755	-0.5098
0.700	-0.2614	-0.2149	-0.1239	-0.1817	-0.4367
0.725	*****	-0.2382	*****	-0.1901	-0.3698
0.750	-0.2741	-0.2619	*****	-0.2019	-0.2842
0.775	*****	-0.2893	-0.1898	-0.2249	-0.2078
0.800	-0.2796	-0.3152	-0.2253	-0.2473	*****
0.825	*****	-0.3433	-0.2678	-0.2568	-0.2427
0.850	-0.2858	-0.3674	-0.3149	-0.3101	-0.2682
0.875	*****	-0.3929	-0.3682	-0.3646	-0.3607
0.900	-0.2890	-0.4193	-0.4266	-0.4356	-0.6073
0.925	*****	-0.4445	-0.4791	-0.5058	-0.7036
0.950	-0.2952	-0.4601	-0.5337	-0.5761	-0.6950
0.975	*****	-0.5118	-0.6002	-0.6635	-0.7163
1.000	-0.1989	-0.5219	-0.6002	-0.8827	-0.7596
	$C_{p,l}$	$C_{p,l}$	$C_{p,l}$	$C_{p,l}$	$C_{p,l}$
-0.200	0.1056	0.1130	0.1668	*****	-0.6427
-0.400	0.0952	0.1185	0.1348	-0.0198	-0.7338
-0.600	0.1033	0.1143	0.1260	0.0123	-0.7194
-0.700	0.1215	0.1083	0.1197	0.0246	-0.6935
-0.800	0.1552	*****	0.1170	0.0436	-0.6323
-0.850	*****	0.1428	0.1224	0.0494	-0.6371
-0.900	*****	0.1736	0.1463	0.0696	-0.6347
-0.950	0.2369	0.2131	0.1930	0.1260	-0.2319
-0.975	*****	0.2233	0.2118	0.1600	-0.0655
-1.000	-0.2109	-0.4552	-0.7658	-0.8136	-0.6306

Surface Pressures



Medium Radius L.E.
Run No. = 14, Point No. = 291
 $C_N = 0.242$, $C_m = -0.0483$
 $\alpha = 5.8^\circ$, $M_\infty = 0.850$
 $R_{mac} = 60.6 \times 10^6$

Leading Edge Pressures

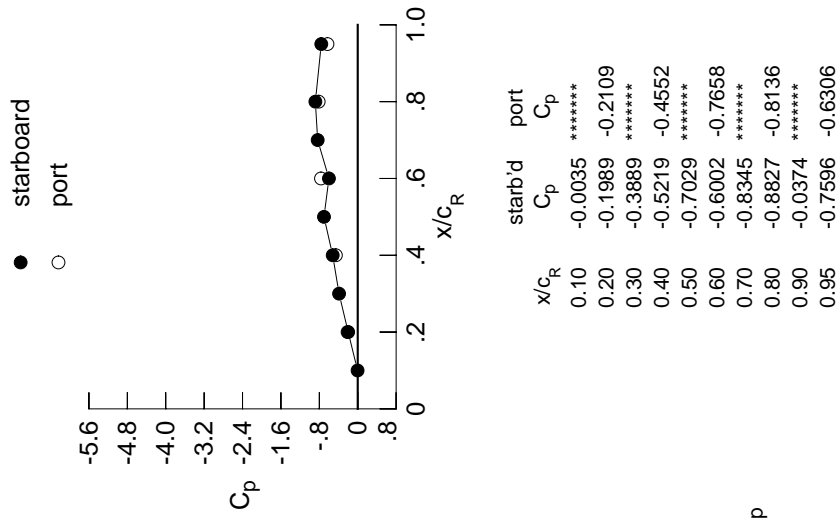
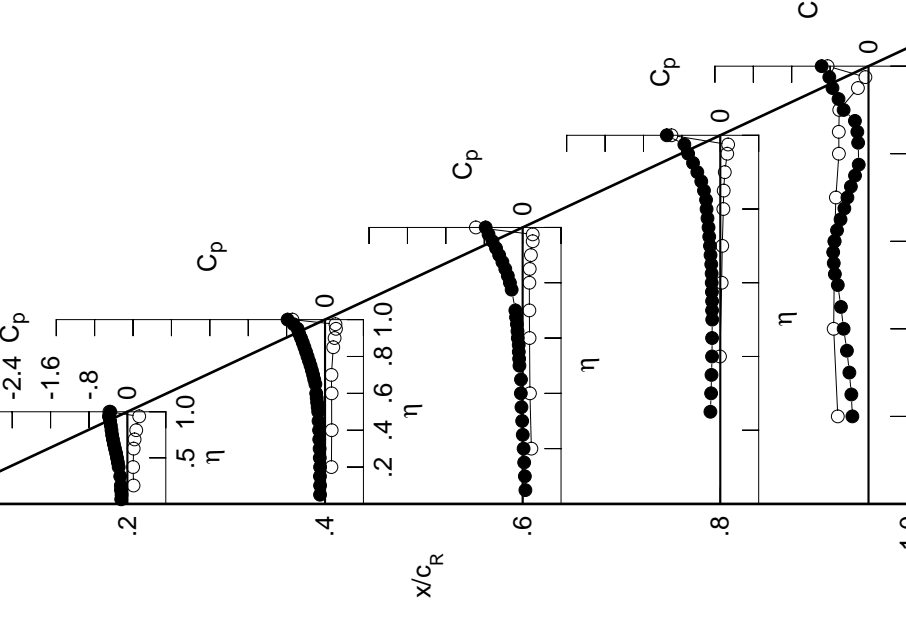
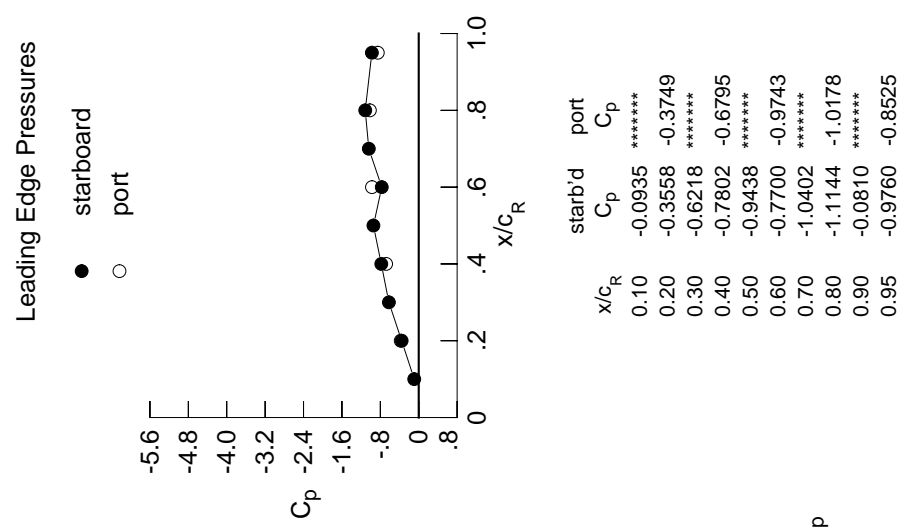

Table E6. Continued.

η	$x/c_R = .2$		$x/c_R = .4$		$x/c_R = .6$		$x/c_R = .8$		$x/c_R = .95$	
	$C_{p,u}$	$C_{p,u}$	$C_{p,u}$	$C_{p,u}$	$C_{p,u}$	$C_{p,u}$	$C_{p,u}$	$C_{p,u}$	$C_{p,u}$	$C_{p,u}$
0.050	-0.1291	-0.1041	0.0574	*****	*****	*****	*****	*****	*****	
0.100	-0.1216	-0.1028	0.0463	*****	*****	*****	*****	*****	*****	
0.150	-0.1342	-0.1066	0.0319	*****	*****	*****	*****	*****	*****	
0.200	-0.1368	-0.1033	0.0201	*****	*****	*****	*****	*****	*****	
0.250	*****	-0.1099	0.0021	-0.2056	-0.3579	*****	*****	*****	*****	
0.300	-0.1492	-0.1128	-0.0097	-0.1914	-0.3986	*****	*****	*****	*****	
0.350	*****	-0.1208	-0.0246	-0.1829	-0.4494	*****	*****	*****	*****	
0.400	-0.1819	-0.1238	-0.0375	-0.1719	-0.5185	*****	*****	*****	*****	
0.450	-0.1985	-0.1352	-0.0340	-0.1708	-0.5744	*****	*****	*****	*****	
0.500	-0.2165	-0.1422	-0.0662	-0.1683	-0.6399	*****	*****	*****	*****	
0.525	*****	-0.1537	-0.0728	-0.1712	-0.7007	*****	*****	*****	*****	
0.550	-0.2349	-0.1648	-0.0801	-0.1705	-0.7244	*****	*****	*****	*****	
0.575	*****	-0.1738	-0.0812	-0.1740	-0.7358	*****	*****	*****	*****	
0.600	-0.2589	-0.1842	-0.1010	-0.1785	-0.7099	*****	*****	*****	*****	
0.625	*****	*****	-0.1071	-0.1797	-0.6563	*****	*****	*****	*****	
0.650	-0.2814	-0.2006	-0.1190	-0.1884	-0.5827	*****	*****	*****	*****	
0.675	*****	-0.2256	-0.1380	-0.2030	-0.5031	*****	*****	*****	*****	
0.700	-0.3007	-0.2477	-0.1524	-0.2156	-0.4390	*****	*****	*****	*****	
0.725	*****	-0.2746	*****	-0.2307	-0.3675	*****	*****	*****	*****	
0.750	-0.3188	-0.3015	*****	-0.2446	-0.2806	*****	*****	*****	*****	
0.775	*****	-0.3330	-0.2291	-0.2662	-0.2041	*****	*****	*****	*****	
0.800	-0.3311	-0.3648	-0.2651	-0.2859	*****	*****	*****	*****	*****	
0.825	*****	-0.3963	-0.3086	-0.2971	-0.2156	*****	*****	*****	*****	
0.850	-0.3450	-0.4299	-0.3613	-0.3400	-0.2330	*****	*****	*****	*****	
0.875	*****	-0.4641	-0.4212	-0.3962	-0.2828	*****	*****	*****	*****	
0.900	-0.3598	-0.5010	-0.4884	-0.4788	-0.5188	*****	*****	*****	*****	
0.925	*****	-0.5412	-0.5545	-0.5682	-0.6245	*****	*****	*****	*****	
0.950	-0.3847	-0.5722	-0.6282	-0.6700	-0.7504	*****	*****	*****	*****	
0.975	*****	-0.6567	-0.7102	-0.7485	-0.8165	*****	*****	*****	*****	
1.000	-0.3558	-0.7802	-0.7700	-1.1144	-0.9760	*****	*****	*****	*****	
-0.200	$C_{p,l}$	0.1278	0.1329	0.1820	*****	*****	*****	*****	*****	
-0.400	$C_{p,l}$	0.1191	0.1388	0.1519	-0.0060	-0.7258	*****	*****	*****	
-0.600	$C_{p,l}$	0.1306	0.1370	0.1440	0.0285	-0.7068	*****	*****	*****	
-0.700	$C_{p,l}$	0.1499	0.1332	0.1400	0.0411	-0.6798	*****	*****	*****	
-0.800	$C_{p,l}$	0.1836	*****	0.1399	0.0637	-0.6172	*****	*****	*****	
-0.850	$C_{p,l}$	*****	0.1713	0.1474	0.0713	-0.6191	*****	*****	*****	
-0.900	$C_{p,l}$	*****	0.1995	0.1717	0.0940	-0.6097	*****	*****	*****	
-0.950	$C_{p,l}$	0.2467	0.2281	0.2094	0.1451	-0.2211	*****	*****	*****	
-0.975	$C_{p,l}$	*****	0.2175	0.2099	0.1633	-0.0644	*****	*****	*****	
-1.000	$C_{p,l}$	-0.3749	-0.6795	-0.9743	-1.0178	-0.8525	*****	*****	*****	

Medium Radius L.E.
 Run No. = 14, Point No. = 292
 $C_N = 0.288$, $C_m = -0.0574$
 $\alpha = 6.9^\circ$, $M_\infty = 0.850$
 $R_{mac} = 60.7 \times 10^6$



x/c_R	starb'd C_p	port C_p
0.10	-0.0935	*****
0.20	-0.3558	-0.3749
0.30	-0.6218	*****
0.40	-0.7802	-0.6795
0.50	-0.9438	*****
0.60	-0.7700	-0.9743
0.70	-1.0402	*****
0.80	-1.1144	-1.0178
0.90	-0.0810	*****
0.95	-0.9760	-0.8525

Table E6. Continued.

η	$x/c_R = .2$		$x/c_R = .4$		$x/c_R = .6$		$x/c_R = .8$		$x/c_R = .95$	
	$C_{p,u}$	$C_{p,u}$	$C_{p,u}$	$C_{p,u}$	$C_{p,u}$	$C_{p,u}$	$C_{p,u}$	$C_{p,u}$	$C_{p,u}$	$C_{p,u}$
0.050	-0.1453	-0.1209	0.0445	*****	*****	*****	*****	*****	*****	*****
0.100	-0.1403	-0.1221	0.0336	*****	*****	*****	*****	*****	*****	*****
0.150	-0.1531	-0.1235	0.0190	*****	*****	*****	*****	*****	*****	*****
0.200	-0.1567	-0.1221	0.0055	*****	*****	*****	*****	*****	*****	*****
0.250	*****	-0.1284	-0.0119	-0.2236	-0.3498	*****	*****	*****	*****	*****
0.300	-0.1694	-0.1325	-0.0239	-0.2088	-0.3722	*****	*****	*****	*****	*****
0.350	*****	-0.1410	-0.0399	-0.2007	-0.4102	*****	*****	*****	*****	*****
0.400	-0.2041	-0.1454	-0.0526	-0.1900	-0.5421	*****	*****	*****	*****	*****
0.450	-0.2226	-0.1577	-0.0507	-0.1865	-0.7019	*****	*****	*****	*****	*****
0.500	-0.2421	-0.1659	-0.0827	-0.1859	-0.7362	*****	*****	*****	*****	*****
0.525	*****	-0.1783	-0.0919	-0.1907	-0.7410	*****	*****	*****	*****	*****
0.550	-0.2641	-0.1911	-0.1005	-0.1952	-0.7125	*****	*****	*****	*****	*****
0.575	*****	-0.2014	-0.1050	-0.2038	-0.6928	*****	*****	*****	*****	*****
0.600	-0.2911	-0.2148	-0.1333	-0.2146	-0.6613	*****	*****	*****	*****	*****
0.625	*****	*****	-0.1417	-0.2211	-0.6296	*****	*****	*****	*****	*****
0.650	-0.3178	-0.2357	-0.1603	-0.2313	-0.6002	*****	*****	*****	*****	*****
0.675	*****	-0.2588	-0.1796	-0.2450	-0.5601	*****	*****	*****	*****	*****
0.700	-0.3426	-0.2837	-0.1949	-0.2606	-0.5439	*****	*****	*****	*****	*****
0.725	*****	-0.3113	*****	-0.2813	-0.5344	*****	*****	*****	*****	*****
0.750	-0.3674	-0.3418	*****	-0.2899	-0.5153	*****	*****	*****	*****	*****
0.775	*****	-0.3769	-0.2627	-0.3024	-0.5259	*****	*****	*****	*****	*****
0.800	-0.3856	-0.4135	-0.2970	-0.3207	*****	*****	*****	*****	*****	*****
0.825	*****	-0.4535	-0.3414	-0.3670	-0.5561	*****	*****	*****	*****	*****
0.850	-0.4078	-0.4941	-0.3958	-0.4306	-0.5362	*****	*****	*****	*****	*****
0.875	*****	-0.5374	-0.4611	-0.4329	-0.6442	*****	*****	*****	*****	*****
0.900	-0.4340	-0.5859	-0.5350	-0.4846	-0.6730	*****	*****	*****	*****	*****
0.925	*****	-0.6394	-0.6135	-0.6524	-0.8312	*****	*****	*****	*****	*****
0.950	-0.4879	-0.6838	-0.7219	-0.7970	-0.6465	*****	*****	*****	*****	*****
0.975	*****	-0.7772	-1.0723	-0.9856	-0.7259	*****	*****	*****	*****	*****
1.000	-0.5492	-0.9950	-0.8805	-1.2319	-1.0501	*****	*****	*****	*****	*****
-0.200	$C_{p,l}$	$C_{p,l}$	$C_{p,l}$	$C_{p,l}$	$C_{p,l}$	$C_{p,l}$	$C_{p,l}$	$C_{p,l}$	$C_{p,l}$	$C_{p,l}$
-0.400	0.1503	0.1525	0.1969	*****	*****	-0.6374	*****	*****	*****	*****
-0.600	0.1438	0.1586	0.1688	0.0090	-0.7131	*****	*****	*****	*****	*****
-0.700	0.1574	0.1606	0.1619	0.0436	-0.6924	*****	*****	*****	*****	*****
-0.800	0.1778	0.1584	0.1597	0.0582	-0.6651	*****	*****	*****	*****	*****
-0.850	0.2098	*****	0.1623	0.0807	-0.5996	*****	*****	*****	*****	*****
-0.900	*****	0.1974	0.1722	0.0915	-0.5992	*****	*****	*****	*****	*****
-0.950	*****	0.2223	0.1937	0.1161	-0.5824	*****	*****	*****	*****	*****
-0.975	0.2517	0.2377	0.2205	0.1595	-0.2058	*****	*****	*****	*****	*****
-1.000	*****	0.2048	0.2016	0.1630	-0.0544	*****	*****	*****	*****	*****
	-0.5749	-0.8830	-1.1294	-1.1525	-0.9103	*****	*****	*****	*****	*****

Medium Radius L.E.
 Run No. = 14, Point No. = 293
 $C_N = 0.339$, $C_m = -0.0672$
 $\alpha = 7.9^\circ$, $M_\infty = 0.852$
 $R_{mac} = 60.6 \times 10^6$

Leading Edge Pressures

● starboard
 ○ port

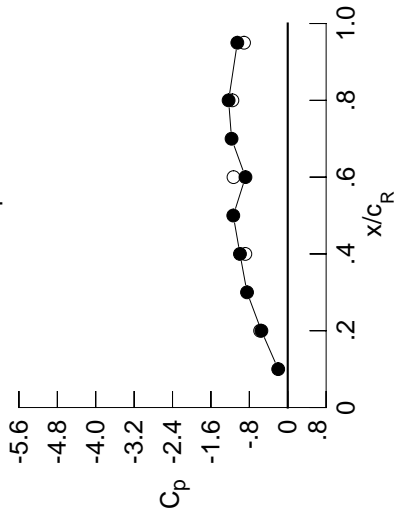

x/c_R	starb'd C_p	port C_p
0.10	-0.1984	*****
0.20	-0.5492	-0.5749
0.30	-0.8481	*****
0.40	-0.9950	-0.8830
0.50	-1.1346	*****
0.60	-0.8805	-1.1294
0.70	-1.1702	*****
0.80	-1.2319	-1.1525
0.90	-0.0981	*****
0.95	-1.0501	-0.9103

Surface Pressures

● upper, starboard
 ○ lower, port

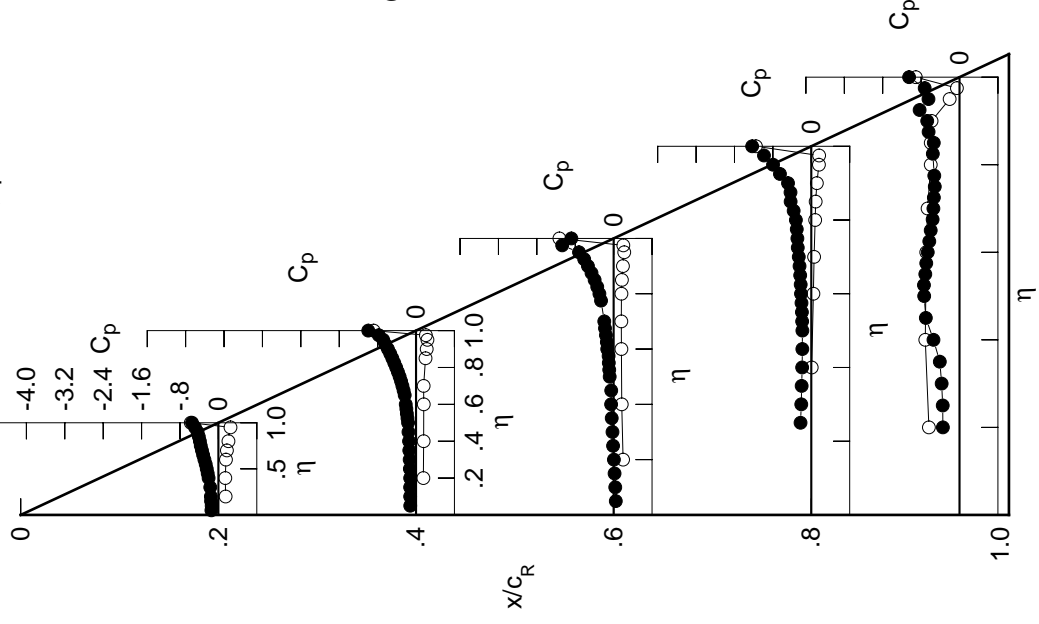
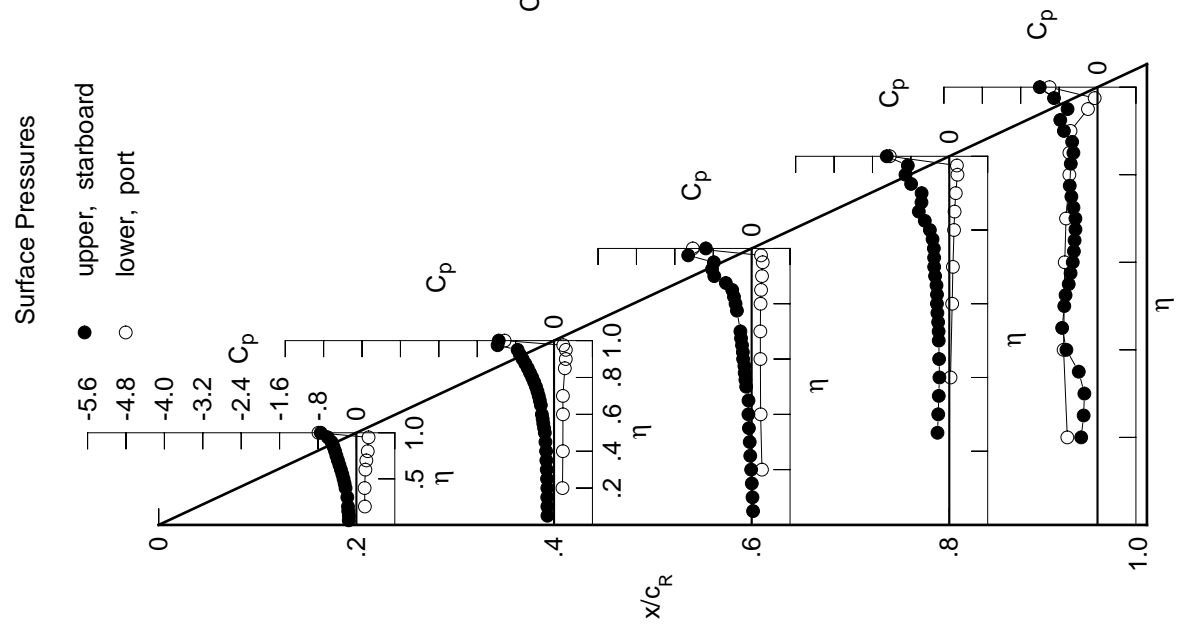
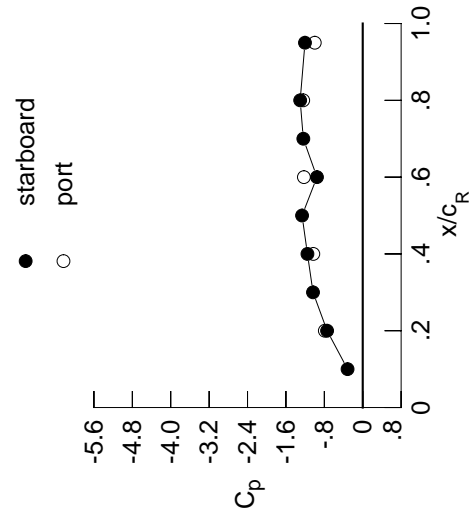

Table E6. Continued.

η	$x/c_R = .2$		$x/c_R = .4$		$x/c_R = .6$		$x/c_R = .8$		$x/c_R = .95$	
	$C_{p,u}$	$C_{p,u}$	$C_{p,u}$	$C_{p,u}$	$C_{p,u}$	$C_{p,u}$	$C_{p,u}$	$C_{p,u}$	$C_{p,u}$	$C_{p,u}$
0.050	-0.1591	-0.1375	0.0299	*****	*****	*****	*****	*****	*****	
0.100	-0.1566	-0.1392	0.0178	*****	*****	*****	*****	*****	*****	
0.150	-0.1706	-0.1414	0.0031	*****	*****	*****	*****	*****	*****	
0.200	-0.1752	-0.1400	-0.0101	*****	*****	*****	*****	*****	-0.3396	
0.250	*****	-0.1460	-0.0286	-0.2454	-0.2887	*****	*****	*****	*****	
0.300	-0.1892	-0.1519	-0.0402	-0.2303	-0.2732	*****	*****	*****	*****	
0.350	*****	-0.1601	-0.0568	-0.2190	-0.3907	*****	*****	*****	*****	
0.400	-0.2256	-0.1659	-0.0670	-0.2059	-0.6483	*****	*****	*****	*****	
0.450	-0.2459	-0.1788	-0.0654	-0.2110	-0.7371	*****	*****	*****	*****	
0.500	-0.2682	-0.1920	-0.1147	-0.2197	-0.6916	*****	*****	*****	*****	
0.525	*****	-0.2072	-0.1302	-0.2228	-0.6660	*****	*****	*****	*****	
0.550	-0.2928	-0.2238	-0.1446	-0.2320	-0.6001	*****	*****	*****	*****	
0.575	*****	-0.2366	-0.1514	-0.2479	-0.5604	*****	*****	*****	*****	
0.600	-0.3232	-0.2533	-0.1778	-0.2569	-0.5157	*****	*****	*****	*****	
0.625	*****	*****	-0.1830	-0.2558	-0.4916	*****	*****	*****	*****	
0.650	-0.3540	-0.2749	-0.2006	-0.2664	-0.4775	*****	*****	*****	*****	
0.675	*****	-0.2971	-0.2209	-0.2957	-0.4591	*****	*****	*****	*****	
0.700	-0.3845	-0.3195	-0.2347	-0.3154	-0.4599	*****	*****	*****	*****	
0.725	*****	-0.3459	*****	-0.3159	-0.5005	*****	*****	*****	*****	
0.750	-0.4163	-0.3764	*****	-0.3214	-0.5445	*****	*****	*****	*****	
0.775	*****	-0.4142	-0.3065	-0.3487	-0.5781	*****	*****	*****	*****	
0.800	-0.4440	-0.4550	-0.3355	-0.4046	*****	*****	*****	*****	*****	
0.825	*****	-0.5005	-0.3680	-0.5107	-0.5565	*****	*****	*****	*****	
0.850	-0.4775	-0.5461	-0.4047	-0.6353	-0.5024	*****	*****	*****	*****	
0.875	*****	-0.5992	-0.5378	-0.5796	-0.5290	*****	*****	*****	*****	
0.900	-0.5186	-0.6552	-0.7782	-0.5772	-0.7010	*****	*****	*****	*****	
0.925	*****	-0.7139	-0.8254	-0.7952	-0.7762	*****	*****	*****	*****	
0.950	-0.5949	-0.7591	-0.7883	-0.9124	-0.6241	*****	*****	*****	*****	
0.975	*****	-1.1760	-1.3216	-0.8637	-0.9061	*****	*****	*****	*****	
1.000	-0.7422	-1.1517	-0.9539	-1.3033	-1.2031	*****	*****	*****	*****	
-0.200	$C_{p,l}$	0.1769	$C_{p,l}$	0.2153	*****	$C_{p,l}$	0.2153	*****	-0.6289	
-0.400	$C_{p,l}$	0.1710	$C_{p,l}$	0.1836	0.1872	$C_{p,l}$	0.0255	-0.7067	*****	
-0.600	$C_{p,l}$	0.1872	$C_{p,l}$	0.1856	0.1821	$C_{p,l}$	0.0604	-0.6829	*****	
-0.700	$C_{p,l}$	0.2073	$C_{p,l}$	0.1850	0.1811	$C_{p,l}$	0.0753	-0.6554	*****	
-0.800	$C_{p,l}$	0.2370	*****	0.1857	0.0995	$C_{p,l}$	0.0995	-0.5861	*****	
-0.850	$C_{p,l}$	*****	0.2246	0.1958	0.1108	$C_{p,l}$	0.1108	-0.5856	*****	
-0.900	$C_{p,l}$	*****	0.2446	0.2162	0.1349	$C_{p,l}$	0.1349	-0.5624	*****	
-0.950	$C_{p,l}$	0.2539	0.2459	0.2306	0.1707	$C_{p,l}$	0.1707	-0.1993	*****	
-0.975	$C_{p,l}$	*****	0.1912	0.1949	0.1580	$C_{p,l}$	0.1580	-0.0596	*****	
-1.000	$C_{p,l}$	-0.7895	-1.0299	-1.2259	-1.2403	$C_{p,l}$	-1.2403	-0.9993	*****	

Medium Radius L.E.
 Run No. = 14, Point No. = 294
 $C_N = 0.392$, $C_m = -0.0775$
 $\alpha = 8.9^\circ$, $M_\infty = 0.850$
 $R_{mac} = 60.5 \times 10^6$

Leading Edge Pressures



x/c_R	starb'd C_p	port C_p
0.10	-0.3160	*****
0.20	-0.7422	-0.7895
0.30	-1.0356	*****
0.40	-1.1517	-1.0299
0.50	-1.2640	*****
0.60	-0.9539	-1.2259
0.70	-1.2378	*****
0.80	-1.3033	-1.2403
0.90	-0.1136	*****
0.95	-1.2031	-0.9993

Table E6. Continued.

η	$x/c_R = .2$		$x/c_R = .4$		$x/c_R = .6$		$x/c_R = .8$		$x/c_R = .95$	
	$C_{p,u}$	$C_{p,u}$	$C_{p,u}$	$C_{p,u}$	$C_{p,u}$	$C_{p,u}$	$C_{p,u}$	$C_{p,u}$	$C_{p,u}$	$C_{p,u}$
0.050	-0.1593	-0.1380	0.0296	*****	*****	*****	*****	*****	*****	*****
0.100	-0.1560	-0.1394	0.0179	*****	*****	*****	*****	*****	*****	*****
0.150	-0.1704	-0.1418	0.0027	*****	*****	*****	*****	*****	*****	*****
0.200	-0.1743	-0.1399	-0.0105	*****	*****	*****	*****	*****	*****	-0.3373
0.250	*****	-0.1469	-0.0293	-0.2451	-0.2822	*****	*****	*****	*****	*****
0.300	-0.1889	-0.1508	-0.0404	-0.2303	-0.2650	*****	*****	*****	*****	*****
0.350	*****	-0.1611	-0.0563	-0.2191	-0.3817	*****	*****	*****	*****	*****
0.400	-0.2258	-0.1660	-0.0674	-0.2061	-0.6364	*****	*****	*****	*****	*****
0.450	-0.2457	-0.1790	-0.0659	-0.2108	-0.7310	*****	*****	*****	*****	*****
0.500	-0.2676	-0.1915	-0.1147	-0.2196	-0.6878	*****	*****	*****	*****	*****
0.525	*****	-0.2076	-0.1312	-0.2230	-0.6601	*****	*****	*****	*****	*****
0.550	-0.2920	-0.2236	-0.1450	-0.2322	-0.5927	*****	*****	*****	*****	*****
0.575	*****	-0.2377	-0.1526	-0.2480	-0.5514	*****	*****	*****	*****	*****
0.600	-0.3234	-0.2537	-0.1781	-0.2576	-0.5081	*****	*****	*****	*****	*****
0.625	*****	*****	-0.1844	-0.2567	-0.4854	*****	*****	*****	*****	*****
0.650	-0.3542	-0.2756	-0.2009	-0.2696	-0.4753	*****	*****	*****	*****	*****
0.675	*****	-0.2978	-0.2226	-0.2992	-0.4628	*****	*****	*****	*****	*****
0.700	-0.3847	-0.3191	-0.2350	-0.3130	-0.4635	*****	*****	*****	*****	*****
0.725	*****	-0.3459	*****	-0.3055	-0.5073	*****	*****	*****	*****	*****
0.750	-0.4163	-0.3768	*****	-0.3050	-0.5634	*****	*****	*****	*****	*****
0.775	*****	-0.4143	-0.3106	-0.3323	-0.6000	*****	*****	*****	*****	*****
0.800	-0.4437	-0.4560	-0.3415	-0.4100	*****	*****	*****	*****	*****	*****
0.825	*****	-0.4999	-0.3720	-0.5471	-0.5693	*****	*****	*****	*****	*****
0.850	-0.4772	-0.5472	-0.4070	-0.6548	-0.5136	*****	*****	*****	*****	*****
0.875	*****	-0.5993	-0.5284	-0.5903	-0.5431	*****	*****	*****	*****	*****
0.900	-0.5184	-0.6564	-0.7782	-0.5768	-0.6980	*****	*****	*****	*****	*****
0.925	*****	-0.7134	-0.8185	-0.7916	-0.7789	*****	*****	*****	*****	*****
0.950	-0.5949	-0.7622	-0.7863	-0.9070	-0.6283	*****	*****	*****	*****	*****
0.975	*****	-1.1804	-1.3301	-0.8583	-0.9015	*****	*****	*****	*****	*****
1.000	-0.7429	-1.1537	-0.9562	-1.3041	-1.2031	*****	*****	*****	*****	*****
-0.200	$C_{p,l}$	0.1773	0.1761	0.2154	*****	*****	*****	*****	*****	-0.6278
-0.400	$C_{p,l}$	0.1714	0.1833	0.1872	0.0250	-0.7063	*****	*****	*****	*****
-0.600	$C_{p,l}$	0.1874	0.1864	0.1817	0.0613	-0.6834	*****	*****	*****	*****
-0.700	$C_{p,l}$	0.2079	0.1864	0.1817	0.0755	-0.6544	*****	*****	*****	*****
-0.800	$C_{p,l}$	0.2377	*****	0.1867	0.1002	-0.5859	*****	*****	*****	*****
-0.850	$C_{p,l}$	*****	0.2253	0.1965	0.1119	-0.5852	*****	*****	*****	*****
-0.900	$C_{p,l}$	*****	0.2445	0.2166	0.1356	-0.5617	*****	*****	*****	*****
-0.950	$C_{p,l}$	0.2540	0.2460	0.2310	0.1710	-0.1985	*****	*****	*****	*****
-0.975	$C_{p,l}$	*****	0.1913	0.1950	0.1583	-0.0598	*****	*****	*****	*****
-1.000	$C_{p,l}$	-0.7902	-1.0304	-1.2267	-1.2411	-1.0021	*****	*****	*****	*****

Medium Radius L.E.
 Run No. = 14, Point No. = 295
 $C_N = 0.395$, $C_m = -0.0791$
 $\alpha = 9.0^\circ$, $M_\infty = 0.849$
 $R_{mac} = 60.6 \times 10^6$

Leading Edge Pressures

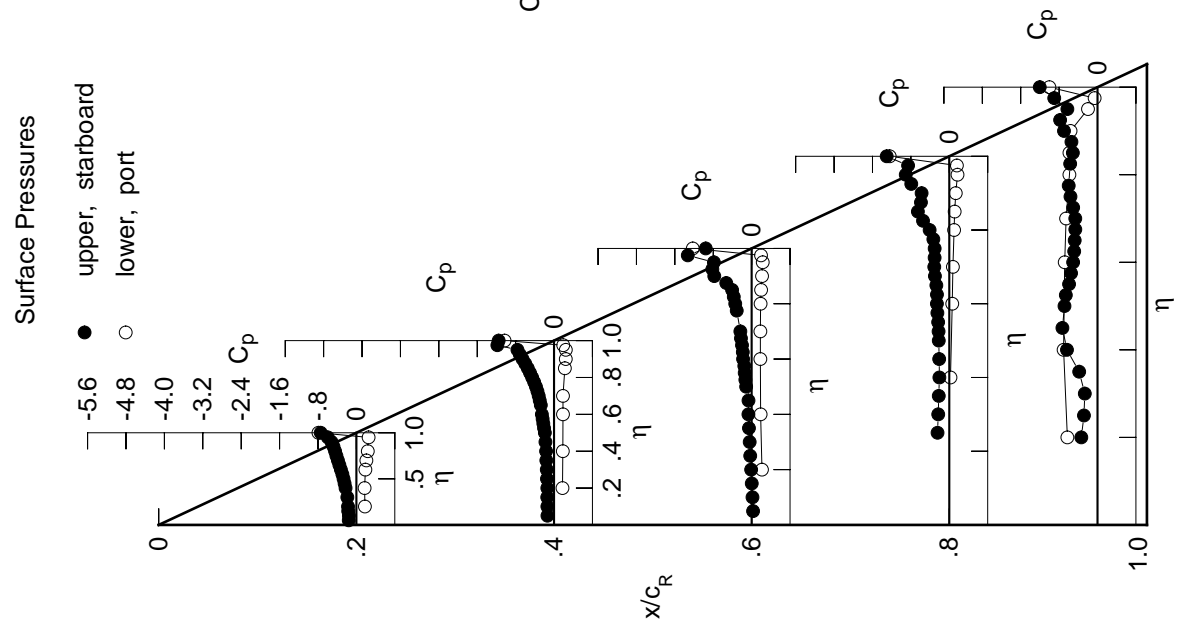
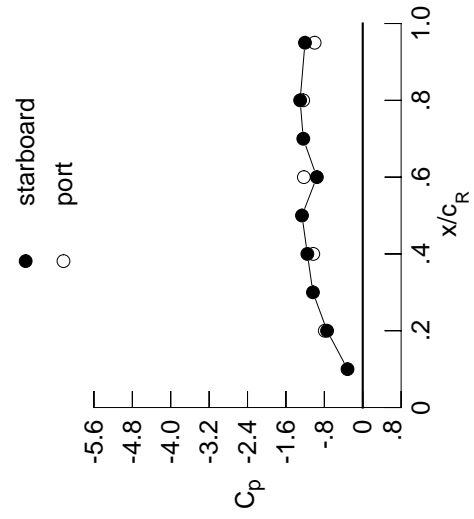
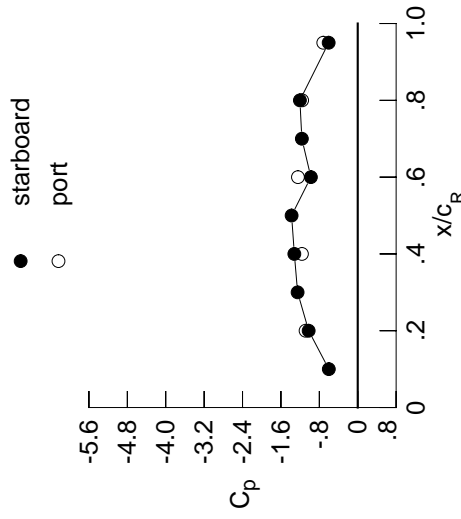

Table E6. Continued.

η	$x/c_R = .2$		$x/c_R = .4$		$x/c_R = .6$		$x/c_R = .8$		$x/c_R = .95$	
	$C_{p,u}$	$C_{p,u}$	$C_{p,u}$	$C_{p,u}$	$C_{p,u}$	$C_{p,u}$	$C_{p,u}$	$C_{p,u}$	$C_{p,u}$	$C_{p,u}$
0.050	-0.1895	-0.1855	-0.0166	*****	*****	*****	*****	*****	*****	*****
0.100	-0.1883	-0.1879	-0.0291	*****	*****	*****	*****	*****	*****	*****
0.150	-0.2086	-0.1912	-0.0469	*****	*****	*****	*****	*****	*****	*****
0.200	-0.2155	-0.1918	-0.0593	*****	*****	*****	*****	*****	*****	-0.1964
0.250	*****	-0.1984	-0.0736	-0.3002	-0.2240	*****	*****	*****	*****	-0.2240
0.300	-0.2334	-0.2005	-0.0876	-0.2820	-0.3696	*****	*****	*****	*****	-0.3696
0.350	*****	-0.2128	-0.1117	-0.2734	-0.5072	*****	*****	*****	*****	-0.5072
0.400	-0.2724	-0.2337	-0.1356	-0.2634	-0.6433	*****	*****	*****	*****	-0.6433
0.450	-0.2960	-0.2616	-0.1524	-0.2624	-0.6826	*****	*****	*****	*****	-0.6826
0.500	-0.3224	-0.2795	-0.1886	-0.2747	-0.6295	*****	*****	*****	*****	-0.6295
0.525	*****	-0.2961	-0.2003	-0.2768	-0.6418	*****	*****	*****	*****	-0.6418
0.550	-0.3527	-0.3094	-0.2166	-0.2720	-0.6489	*****	*****	*****	*****	-0.6489
0.575	*****	-0.3198	-0.2452	-0.2702	-0.6786	*****	*****	*****	*****	-0.6786
0.600	-0.3897	-0.3274	-0.3057	-0.2767	-0.6835	*****	*****	*****	*****	-0.6835
0.625	*****	*****	-0.3201	-0.2865	-0.6987	*****	*****	*****	*****	-0.6987
0.650	-0.4288	-0.3564	-0.3317	-0.3363	-0.7575	*****	*****	*****	*****	-0.7575
0.675	*****	-0.3923	-0.3454	-0.4571	-0.8505	*****	*****	*****	*****	-0.8505
0.700	-0.4705	-0.4107	-0.3679	-0.6326	-0.9533	*****	*****	*****	*****	-0.9533
0.725	*****	-0.4284	*****	-0.8064	-1.0024	*****	*****	*****	*****	-1.0024
0.750	-0.5174	-0.4402	*****	-0.9021	-1.0036	*****	*****	*****	*****	-1.0036
0.775	*****	-0.4483	-0.6656	-0.9544	-0.9174	*****	*****	*****	*****	-0.9174
0.800	-0.5659	-0.4890	-0.7312	-0.9231	*****	*****	*****	*****	*****	-0.9231
0.825	*****	-0.6696	-0.7668	-0.8992	-0.6832	*****	*****	*****	*****	-0.6832
0.850	-0.6105	-0.8776	-0.8403	-0.8433	-0.6149	*****	*****	*****	*****	-0.6149
0.875	*****	-0.9690	-0.9704	-0.8048	-0.5710	*****	*****	*****	*****	-0.5710
0.900	-0.6753	-0.8841	-0.9779	-0.8001	-0.5430	*****	*****	*****	*****	-0.5430
0.925	*****	-0.9675	-0.9184	-0.7819	-0.5206	*****	*****	*****	*****	-0.5206
0.950	-0.7771	-1.3493	-0.9954	-0.7220	-0.4647	*****	*****	*****	*****	-0.4647
0.975	*****	-1.3922	-0.9880	-0.6838	-0.3836	*****	*****	*****	*****	-0.3836
1.000	-1.0220	-1.3205	-0.9760	-1.2046	-0.6056	*****	*****	*****	*****	-0.6056
-0.200	$C_{p,l}$	$C_{p,l}$	$C_{p,l}$	$C_{p,l}$	$C_{p,l}$	$C_{p,l}$	$C_{p,l}$	$C_{p,l}$	$C_{p,l}$	$C_{p,l}$
-0.400	0.2308	0.2242	0.2513	*****	-0.6193	*****	*****	*****	*****	-0.6193
-0.600	0.2279	0.2320	0.2263	0.0580	-0.6866	*****	*****	*****	*****	-0.6866
-0.700	0.2465	0.2371	0.2228	0.0937	-0.6620	*****	*****	*****	*****	-0.6620
-0.800	0.2670	0.2388	0.2240	0.1095	-0.6311	*****	*****	*****	*****	-0.6311
-0.850	0.2889	*****	0.2310	0.1343	-0.5612	*****	*****	*****	*****	-0.5612
-0.900	*****	0.2736	0.2410	0.1467	-0.5569	*****	*****	*****	*****	-0.5569
-0.950	*****	0.2820	0.2556	0.1694	-0.5250	*****	*****	*****	*****	-0.5250
-0.975	0.2525	0.2561	0.2493	0.1896	-0.1779	*****	*****	*****	*****	-0.1779
-1.000	*****	0.1647	0.1857	0.1579	-0.0467	*****	*****	*****	*****	-0.0467
-1.000	-1.0864	-1.1627	-1.2459	-1.1585	-0.7175	*****	*****	*****	*****	-0.7175

Medium Radius L.E.
 Run No. = 14, Point No. = 296
 $C_N = 0.516$, $C_m = -0.1009$
 $\alpha = 11.1^\circ$, $M_\infty = 0.851$
 $R_{mac} = 60.5 \times 10^6$

Leading Edge Pressures



x/c_R	starb'd C_p	port C_p
0.10	-0.6022	*****
0.20	-1.0220	-1.0864
0.30	-1.2528	*****
0.40	-1.3205	-1.1627
0.50	-1.3778	*****
0.60	-0.9760	-1.2459
0.70	-1.1641	*****
0.80	-1.2046	-1.1585
0.90	-0.1049	*****
0.95	-0.6056	-0.7175

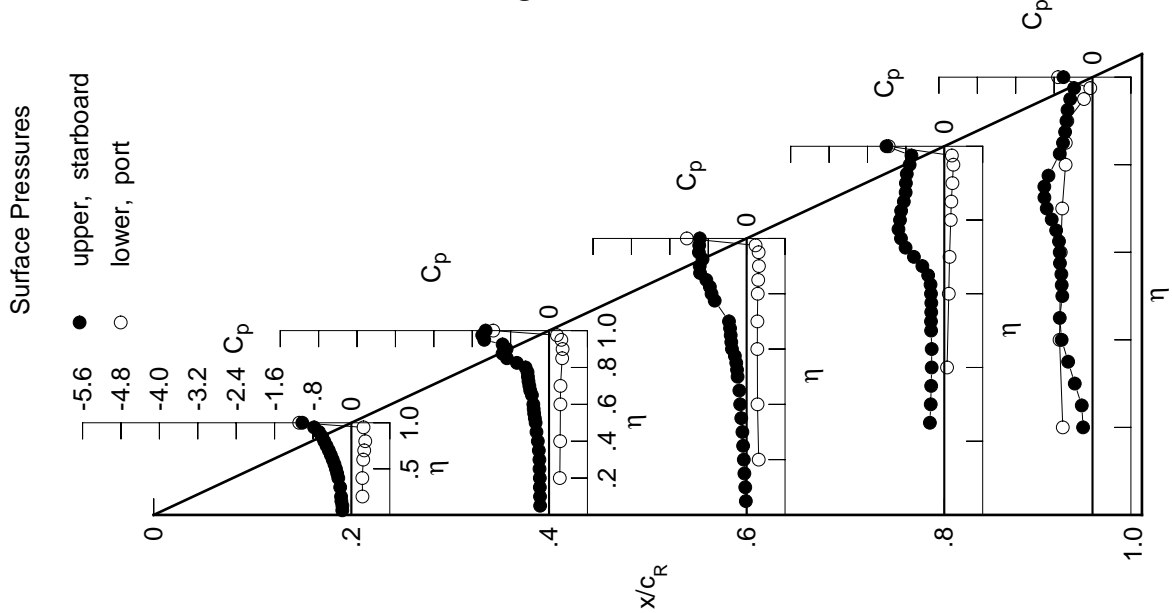

Table E6. Continued.

η	$x/c_R = .2$		$x/c_R = .4$		$x/c_R = .6$		$x/c_R = .8$		$x/c_R = .95$	
	$C_{p,u}$	$C_{p,u}$	$C_{p,u}$	$C_{p,u}$	$C_{p,u}$	$C_{p,u}$	$C_{p,u}$	$C_{p,u}$	$C_{p,u}$	$C_{p,u}$
0.050	-0.2075	-0.2173	-0.0402	*****	*****	*****	*****	*****	*****	*****
0.100	-0.1990	-0.2185	-0.0527	*****	*****	*****	*****	*****	*****	*****
0.150	-0.2288	-0.2226	-0.0717	*****	*****	*****	*****	*****	*****	*****
0.200	-0.2376	-0.2239	-0.0780	*****	*****	*****	*****	*****	*****	*****
0.250	*****	-0.2245	-0.0984	-0.3301	-0.3144	-0.3937	*****	*****	*****	*****
0.300	-0.2591	-0.2329	-0.1153	-0.3144	-0.3937	*****	*****	*****	*****	*****
0.350	*****	-0.2567	-0.1443	-0.3117	-0.4261	*****	*****	*****	*****	*****
0.400	-0.3009	-0.2789	-0.1716	-0.3080	-0.4533	*****	*****	*****	*****	*****
0.450	-0.3278	-0.3148	-0.1909	-0.2944	-0.5014	*****	*****	*****	*****	*****
0.500	-0.3548	-0.3223	-0.2180	-0.2826	-0.6396	*****	*****	*****	*****	*****
0.525	*****	-0.3242	-0.2174	-0.2758	-0.6931	*****	*****	*****	*****	*****
0.550	-0.3837	-0.3286	-0.2169	-0.2638	-0.6945	*****	*****	*****	*****	*****
0.575	*****	-0.3339	-0.2148	-0.2638	-0.7025	*****	*****	*****	*****	*****
0.600	-0.4212	-0.3454	-0.2408	-0.2813	-0.7109	*****	*****	*****	*****	*****
0.625	*****	*****	-0.2552	-0.3374	-0.7703	*****	*****	*****	*****	*****
0.650	-0.4654	-0.4035	-0.3654	-0.4833	-0.8982	*****	*****	*****	*****	*****
0.675	*****	-0.4658	-0.5398	-0.7144	-1.0444	*****	*****	*****	*****	*****
0.700	-0.5141	-0.4910	-0.6698	-0.9286	-1.1765	*****	*****	*****	*****	*****
0.725	*****	-0.5013	*****	-1.0645	-1.2283	*****	*****	*****	*****	*****
0.750	-0.5689	-0.5034	*****	-1.0882	-1.1787	*****	*****	*****	*****	*****
0.775	*****	-0.4643	-0.9263	-1.0833	-0.9342	*****	*****	*****	*****	*****
0.800	-0.6124	-0.4353	-0.9309	-1.0245	*****	*****	*****	*****	*****	*****
0.825	*****	-0.6616	-0.9492	-0.9836	-0.6572	*****	*****	*****	*****	*****
0.850	-0.6697	-1.2118	-0.9825	-0.9018	-0.5796	*****	*****	*****	*****	*****
0.875	*****	-1.3332	-1.0128	-0.8425	-0.5392	*****	*****	*****	*****	*****
0.900	-0.7474	-1.1602	-0.9608	-0.8040	-0.5231	*****	*****	*****	*****	*****
0.925	*****	-1.1516	-0.8955	-0.7628	-0.5135	*****	*****	*****	*****	*****
0.950	-1.1695	-1.3256	-0.9485	-0.7089	-0.4543	*****	*****	*****	*****	*****
0.975	*****	-1.3011	-0.9314	-0.6644	-0.3988	*****	*****	*****	*****	*****
1.000	-1.1289	-1.3691	-0.9430	-1.0731	-0.5664	*****	*****	*****	*****	*****
-0.200	$C_{p,l}$	$C_{p,l}$	$C_{p,l}$	$C_{p,l}$	$C_{p,l}$	$C_{p,l}$	$C_{p,l}$	$C_{p,l}$	$C_{p,l}$	$C_{p,l}$
-0.400	0.2599	0.2480	0.2696	*****	*****	*****	*****	*****	*****	*****
-0.600	0.2587	0.2571	0.2444	0.0740	0.0740	0.0740	0.0740	0.0740	0.0740	0.0740
-0.700	0.2779	0.2627	0.2426	0.1092	0.1092	0.1092	0.1092	0.1092	0.1092	0.1092
-0.800	0.2964	0.2660	0.2442	0.1246	0.1246	0.1246	0.1246	0.1246	0.1246	0.1246
-0.850	0.3151	*****	0.2513	0.1503	0.1503	0.1503	0.1503	0.1503	0.1503	0.1503
-0.900	*****	0.2973	0.2605	0.1621	0.1621	0.1621	0.1621	0.1621	0.1621	0.1621
-0.950	*****	0.2998	0.2711	0.1835	0.1835	0.1835	0.1835	0.1835	0.1835	0.1835
-0.975	0.2504	0.2610	0.2536	0.1947	0.1947	0.1947	0.1947	0.1947	0.1947	0.1947
-1.000	*****	0.1524	0.1767	0.1505	0.1505	0.1505	0.1505	0.1505	0.1505	0.1505
	-1.1549	-1.1954	-1.1593	-1.0880	-0.5579	*****	*****	*****	*****	*****

Medium Radius L.E.
 Run No. = 14, Point No. = 297
 $C_N = 0.579$, $C_m = -0.1122$
 $\alpha = 12.1^\circ$, $M_\infty = 0.851$
 $R_{mac} = 60.5 \times 10^6$

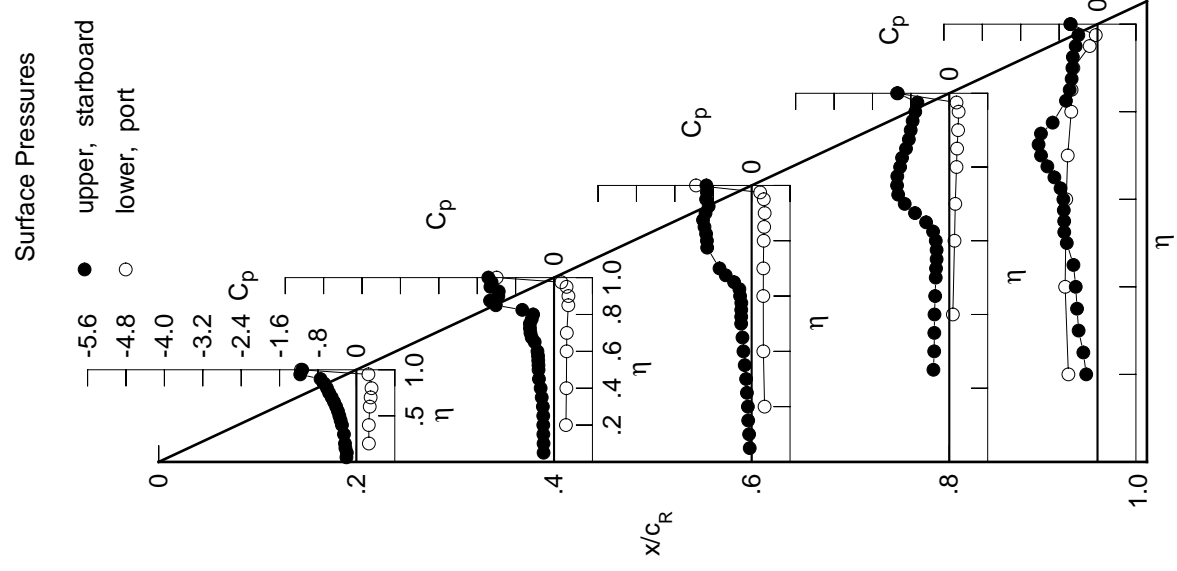
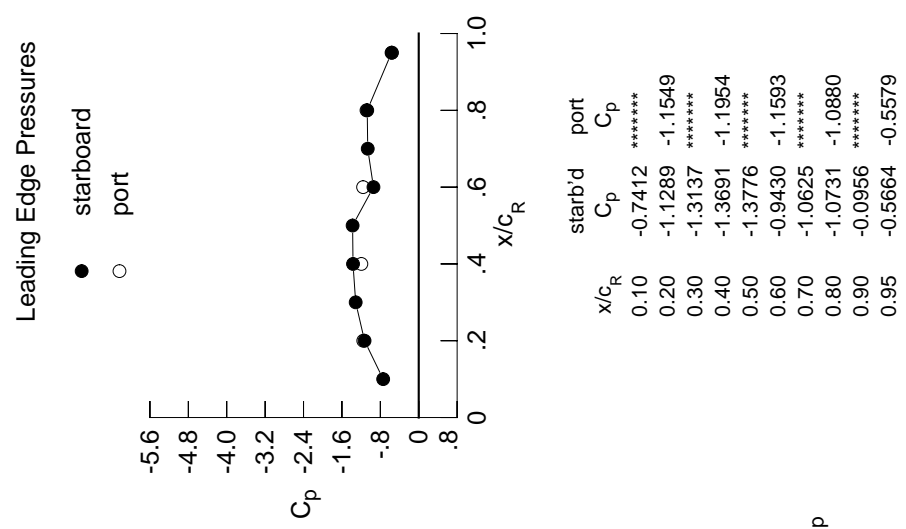
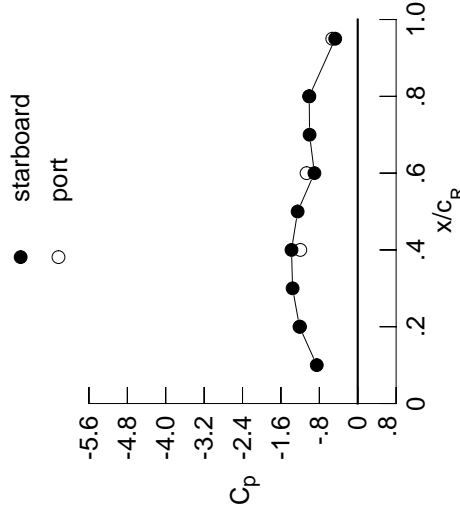

Table E6. Continued.

η	$x/c_R = .2$		$x/c_R = .4$		$x/c_R = .6$		$x/c_R = .8$		$x/c_R = .95$	
	$C_{p,u}$	$C_{p,u}$	$C_{p,u}$	$C_{p,u}$	$C_{p,u}$	$C_{p,u}$	$C_{p,u}$	$C_{p,u}$	$C_{p,u}$	$C_{p,u}$
0.050	-0.2326	-0.2606	-0.0656	*****	*****	*****	*****	*****	*****	*****
0.100	-0.2191	-0.2613	-0.0764	*****	*****	*****	*****	*****	*****	*****
0.150	-0.2527	-0.2630	-0.0943	*****	*****	*****	*****	*****	*****	*****
0.200	-0.2667	-0.2634	-0.1033	*****	*****	*****	*****	*****	*****	-0.2509
0.250	*****	-0.2686	-0.1217	-0.3627	-0.3137	*****	*****	*****	*****	-0.3137
0.300	-0.2940	-0.2817	-0.1371	-0.3469	-0.4288	*****	*****	*****	*****	-0.4288
0.350	*****	-0.3120	-0.1663	-0.3325	-0.5349	*****	*****	*****	*****	-0.5349
0.400	-0.3425	-0.3364	-0.1828	-0.3172	-0.6775	*****	*****	*****	*****	-0.6775
0.450	-0.3641	-0.3830	-0.1881	-0.3143	-0.7065	*****	*****	*****	*****	-0.7065
0.500	-0.3873	-0.3878	-0.2663	-0.3151	-0.6873	*****	*****	*****	*****	-0.6873
0.525	*****	-0.3853	-0.2977	-0.3225	-0.6883	*****	*****	*****	*****	-0.6883
0.550	-0.4166	-0.3901	-0.3188	-0.3364	-0.6904	*****	*****	*****	*****	-0.6904
0.575	*****	-0.3979	-0.3473	-0.3781	-0.7321	*****	*****	*****	*****	-0.7321
0.600	-0.4562	-0.4142	-0.4372	-0.4630	-0.8015	*****	*****	*****	*****	-0.8015
0.625	*****	*****	-0.5067	-0.5968	-0.9286	*****	*****	*****	*****	-0.9286
0.650	-0.5048	-0.5209	-0.6562	-0.7907	-1.0849	*****	*****	*****	*****	-1.0849
0.675	*****	-0.6365	-0.8187	-0.9925	-1.2061	*****	*****	*****	*****	-1.2061
0.700	-0.5547	-0.6927	-0.9271	-1.1415	-1.2830	*****	*****	*****	*****	-1.2830
0.725	*****	-0.6643	*****	-1.2167	-1.2533	*****	*****	*****	*****	-1.2533
0.750	-0.5997	-0.6398	*****	-1.1697	-0.9434	*****	*****	*****	*****	-0.9434
0.775	*****	-0.6493	-1.0334	-1.1219	-0.7812	*****	*****	*****	*****	-0.7812
0.800	-0.6420	-0.6754	-1.0187	-1.0319	*****	*****	*****	*****	*****	*****
0.825	*****	-0.9245	-1.0202	-0.9701	-0.5751	*****	*****	*****	*****	-0.5751
0.850	-0.8354	-1.2564	-1.0139	-0.8758	-0.5144	*****	*****	*****	*****	-0.5144
0.875	*****	-1.3143	-0.9911	-0.8205	-0.4829	*****	*****	*****	*****	-0.4829
0.900	-1.1417	-1.2487	-0.9372	-0.7901	-0.4677	*****	*****	*****	*****	-0.4677
0.925	*****	-1.2129	-0.8976	-0.7551	-0.4576	*****	*****	*****	*****	-0.4576
0.950	-1.3212	-1.2961	-0.8922	-0.7084	-0.3863	*****	*****	*****	*****	-0.3863
0.975	*****	-1.2563	-0.8488	-0.6612	-0.3234	*****	*****	*****	*****	-0.3234
1.000	-1.2132	-1.3800	-0.9026	-1.0109	-0.4691	*****	*****	*****	*****	-0.4691
-0.200	$C_{p,l}$	$C_{p,l}$	$C_{p,l}$	$C_{p,l}$	$C_{p,l}$	$C_{p,l}$	$C_{p,l}$	$C_{p,l}$	$C_{p,l}$	$C_{p,l}$
-0.400	0.2886	0.2713	0.2858	*****	-0.5964	*****	*****	*****	*****	-0.5964
-0.600	0.2880	0.2793	0.2625	0.0880	-0.6651	*****	*****	*****	*****	-0.6651
-0.700	0.3079	0.2865	0.2601	0.1227	-0.6422	*****	*****	*****	*****	-0.6422
-0.800	0.3248	0.2902	0.2617	0.1391	-0.6107	*****	*****	*****	*****	-0.6107
-0.850	0.3386	*****	0.2694	0.1634	-0.5369	*****	*****	*****	*****	-0.5369
-0.900	*****	0.3173	0.2772	0.1757	-0.5283	*****	*****	*****	*****	-0.5283
-0.950	*****	0.3138	0.2834	0.1945	-0.4869	*****	*****	*****	*****	-0.4869
-0.975	0.2476	0.2610	0.2533	0.1965	-0.1593	*****	*****	*****	*****	-0.1593
-1.000	*****	0.1367	0.1624	0.1392	-0.0426	*****	*****	*****	*****	-0.0426
-1.000	-1.2023	-1.1957	-1.0655	-1.0085	-0.5305	*****	*****	*****	*****	-0.5305

Medium Radius L.E.
 Run No. = 14, Point No. = 298
 $C_N = 0.642$, $C_m = -0.1217$
 $\alpha = 13.2^\circ$, $M_\infty = 0.852$
 $R_{mac} = 60.6 \times 10^6$

Leading Edge Pressures



x/c_R	starb'd C_p	port C_p
0.10	-0.8536	*****
0.20	-1.2132	-1.2023
0.30	-1.3570	*****
0.40	-1.3800	-1.1957
0.50	-1.2517	*****
0.60	-0.9026	-1.0655
0.70	-1.0034	*****
0.80	-1.0109	-1.0085
0.90	-0.0840	*****
0.95	-0.4691	-0.5305

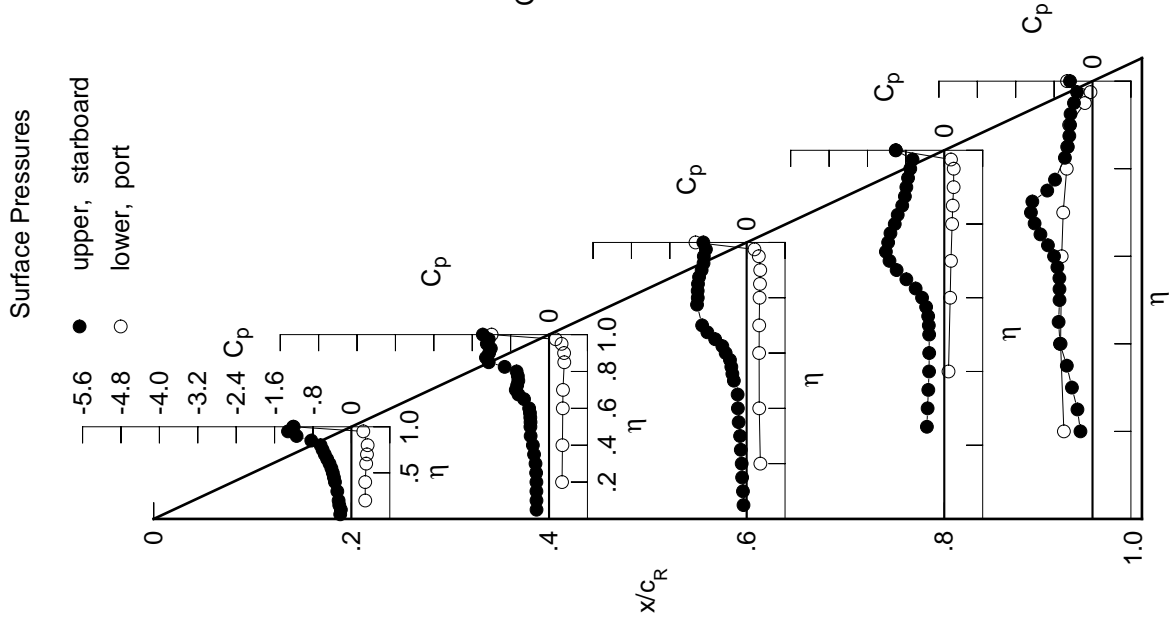
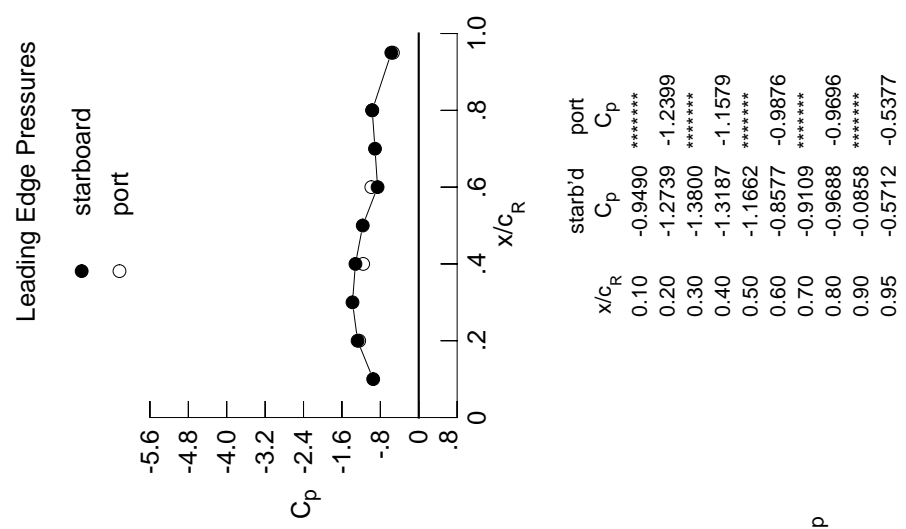

Table E6. Continued.

η	$x/c_R = .2$		$x/c_R = .4$		$x/c_R = .6$		$x/c_R = .8$		$x/c_R = .95$	
	$C_{p,u}$	$C_{p,u}$	$C_{p,u}$	$C_{p,u}$	$C_{p,u}$	$C_{p,u}$	$C_{p,u}$	$C_{p,u}$	$C_{p,u}$	$C_{p,u}$
0.050	-0.2539	-0.3029	-0.0861	*****	*****	*****	*****	*****	*****	*****
0.100	-0.2352	-0.3032	-0.0984	*****	*****	*****	*****	*****	*****	*****
0.150	-0.2698	-0.3051	-0.1131	*****	*****	*****	*****	*****	*****	*****
0.200	-0.2860	-0.3024	-0.1234	*****	*****	*****	*****	*****	*****	*****
0.250	*****	-0.3109	-0.1467	-0.3939	-0.3204	*****	*****	*****	*****	*****
0.300	-0.3345	-0.3319	-0.1608	-0.3804	-0.4413	*****	*****	*****	*****	*****
0.350	*****	-0.3550	-0.1894	-0.3720	-0.5179	*****	*****	*****	*****	*****
0.400	-0.3727	-0.3637	-0.2127	-0.3586	-0.5939	*****	*****	*****	*****	*****
0.450	-0.3898	-0.4092	-0.2044	-0.3527	-0.6590	*****	*****	*****	*****	*****
0.500	-0.4114	-0.4596	-0.2334	-0.3479	-0.6736	*****	*****	*****	*****	*****
0.525	*****	-0.4654	-0.2464	-0.3572	-0.6819	*****	*****	*****	*****	*****
0.550	-0.4455	-0.4616	-0.2699	-0.3825	-0.6987	*****	*****	*****	*****	*****
0.575	*****	-0.4617	-0.3293	-0.4434	-0.7594	*****	*****	*****	*****	*****
0.600	-0.4816	-0.4741	-0.5115	-0.5527	-0.8524	*****	*****	*****	*****	*****
0.625	*****	*****	-0.7062	-0.7174	-0.9938	*****	*****	*****	*****	*****
0.650	-0.5264	-0.5993	-0.9643	-0.9291	-1.1610	*****	*****	*****	*****	*****
0.675	*****	-0.7737	-1.1638	-1.1396	-1.1813	*****	*****	*****	*****	*****
0.700	-0.5765	-0.9550	-1.2622	-1.3048	-0.8601	*****	*****	*****	*****	*****
0.725	*****	-1.0579	*****	-1.4213	-0.8327	*****	*****	*****	*****	*****
0.750	-0.6427	-1.1236	*****	-1.4461	-0.7768	*****	*****	*****	*****	*****
0.775	*****	-1.1910	-1.1707	-1.1909	-0.6959	*****	*****	*****	*****	*****
0.800	-0.9070	-1.2244	-1.1493	-1.0539	*****	*****	*****	*****	*****	*****
0.825	*****	-1.1737	-1.1326	-0.9251	-0.5835	*****	*****	*****	*****	*****
0.850	-1.2272	-1.1452	-1.0764	-0.8668	-0.5444	*****	*****	*****	*****	*****
0.875	*****	-1.1576	-0.9915	-0.8521	-0.5709	*****	*****	*****	*****	*****
0.900	-1.2972	-1.1344	-0.9114	-0.8471	-0.5495	*****	*****	*****	*****	*****
0.925	*****	-1.1121	-0.8679	-0.7535	-0.5609	*****	*****	*****	*****	*****
0.950	-1.3079	-1.2061	-0.8345	-0.7289	-0.5159	*****	*****	*****	*****	*****
0.975	*****	-1.1095	-0.7967	-0.6763	-0.4420	*****	*****	*****	*****	*****
1.000	-1.2739	-1.3187	-0.8577	-0.9688	-0.5712	*****	*****	*****	*****	*****
-0.200	$C_{p,l}$	$C_{p,l}$	$C_{p,l}$	$C_{p,l}$	$C_{p,l}$	$C_{p,l}$	$C_{p,l}$	$C_{p,l}$	$C_{p,l}$	$C_{p,l}$
-0.400	0.3195	0.2978	0.3055	*****	*****	*****	*****	*****	*****	*****
-0.600	0.3188	0.3054	0.2817	0.1032	-0.6547	*****	*****	*****	*****	*****
-0.700	0.3383	0.3109	0.2796	0.1394	-0.6324	*****	*****	*****	*****	*****
-0.800	0.3532	0.3151	0.2821	0.1539	-0.6005	*****	*****	*****	*****	*****
-0.850	0.3624	*****	0.2881	0.1783	-0.5265	*****	*****	*****	*****	*****
-0.900	*****	0.3369	0.2945	0.1895	-0.5163	*****	*****	*****	*****	*****
-0.950	0.2446	0.3269	0.2962	0.2060	-0.4727	*****	*****	*****	*****	*****
-0.975	0.2446	0.3269	0.2962	0.2060	-0.4727	*****	*****	*****	*****	*****
-1.000	-1.2399	-1.1579	-0.9876	-0.9696	-0.5377	*****	*****	*****	*****	*****

Medium Radius L.E.
 Run No. = 14, Point No. = 299
 $C_N = 0.699$, $C_m = -0.1274$
 $\alpha = 14.3^\circ$, $M_\infty = 0.852$
 $R_{mac} = 61.0 \times 10^6$



x/c_R	starb'd C_p	port C_p
0.10	-0.9490	*****
0.20	-1.2739	-1.2399
0.30	-1.3800	*****
0.40	-1.3187	-1.1579
0.50	-1.1662	*****
0.60	-0.8577	-0.9876
0.70	-0.9109	*****
0.80	-0.9688	-0.9696
0.90	-0.0858	*****
0.95	-0.5712	-0.5377

Table E6. Continued.

η	$x/c_R = .2$		$x/c_R = .4$		$x/c_R = .6$		$x/c_R = .8$		$x/c_R = .95$	
	$C_{p,u}$	$C_{p,u}$	$C_{p,u}$	$C_{p,u}$	$C_{p,u}$	$C_{p,u}$	$C_{p,u}$	$C_{p,u}$	$C_{p,u}$	$C_{p,u}$
0.050	-0.3133	-0.3762	-0.1201	*****	*****	*****	*****	*****	*****	*****
0.100	-0.2898	-0.3771	-0.1329	*****	*****	*****	*****	*****	*****	*****
0.150	-0.3198	-0.3709	-0.1447	*****	*****	*****	*****	*****	*****	*****
0.200	-0.3309	-0.3713	-0.1628	*****	*****	*****	*****	*****	*****	-0.5131
0.250	*****	-0.3916	-0.1854	-0.4409	-0.4888	*****	*****	*****	*****	-0.4888
0.300	-0.4197	-0.4003	-0.1973	-0.4273	-0.5104	*****	*****	*****	*****	-0.5104
0.350	*****	-0.4031	-0.2023	-0.4146	-0.5654	*****	*****	*****	*****	-0.5654
0.400	-0.4337	-0.3962	-0.2130	-0.4013	-0.6769	*****	*****	*****	*****	-0.6769
0.450	-0.4516	-0.4095	-0.2077	-0.4108	-0.7003	*****	*****	*****	*****	-0.7003
0.500	-0.4908	-0.4561	-0.3198	-0.4581	-0.7369	*****	*****	*****	*****	-0.7369
0.525	*****	-0.5424	-0.4270	-0.5203	-0.7809	*****	*****	*****	*****	-0.7809
0.550	-0.5147	-0.6741	-0.5943	-0.6163	-0.8492	*****	*****	*****	*****	-0.8492
0.575	*****	-0.8481	-0.7950	-0.7583	-0.9595	*****	*****	*****	*****	-0.9595
0.600	-0.5321	-1.0134	-1.0487	-0.9244	-1.0790	*****	*****	*****	*****	-1.0790
0.625	*****	*****	-1.2114	-1.0980	-1.1894	*****	*****	*****	*****	-1.1894
0.650	-0.6416	-1.2100	-1.3412	-1.2594	-0.7770	*****	*****	*****	*****	-0.7770
0.675	*****	-1.2533	-1.4330	-1.3909	-0.7462	*****	*****	*****	*****	-0.7462
0.700	-0.9399	-1.3026	-1.4517	-1.4768	-0.7096	*****	*****	*****	*****	-0.7096
0.725	*****	-1.3266	*****	-1.2323	-0.6482	*****	*****	*****	*****	-0.6482
0.750	-0.9788	-1.3335	*****	-1.1813	-0.5794	*****	*****	*****	*****	-0.5794
0.775	*****	-1.3280	-1.2146	-1.2092	-0.5288	*****	*****	*****	*****	-0.5288
0.800	-1.0619	-1.2541	-1.1960	-1.2190	*****	*****	*****	*****	*****	*****
0.825	*****	-1.1673	-1.1051	-1.1184	-0.4940	*****	*****	*****	*****	-0.4940
0.850	-1.4169	-1.1245	-1.0259	-1.0159	-0.4809	*****	*****	*****	*****	-0.4809
0.875	*****	-1.1293	-0.9895	-0.9616	-0.5258	*****	*****	*****	*****	-0.5258
0.900	-1.4173	-1.1493	-0.9721	-0.9007	-0.5362	*****	*****	*****	*****	-0.5362
0.925	*****	-1.1664	-0.9327	-0.7818	-0.5674	*****	*****	*****	*****	-0.5674
0.950	-1.3679	-1.1587	-0.8762	-0.7652	-0.5181	*****	*****	*****	*****	-0.5181
0.975	*****	-1.0457	-0.8382	-0.7211	-0.4518	*****	*****	*****	*****	-0.4518
1.000	-1.3866	-1.2257	-0.8606	-0.9217	-0.5372	*****	*****	*****	*****	-0.5372
-0.200	$C_{p,l}$	$C_{p,l}$	$C_{p,l}$	$C_{p,l}$	$C_{p,l}$	$C_{p,l}$	$C_{p,l}$	$C_{p,l}$	$C_{p,l}$	$C_{p,l}$
-0.400	0.3794	0.3454	0.3427	*****	*****	*****	*****	*****	*****	-0.5619
-0.600	0.3790	0.3543	0.3184	0.1348	-0.6355	*****	*****	*****	*****	-0.6355
-0.700	0.3965	0.3584	0.3169	0.1689	-0.6151	*****	*****	*****	*****	-0.6151
-0.800	0.4067	0.3626	0.3185	0.1835	-0.5805	*****	*****	*****	*****	-0.5805
-0.850	0.4057	*****	0.3221	0.2065	-0.5032	*****	*****	*****	*****	-0.5032
-0.900	*****	0.3722	0.3243	0.2161	-0.4886	*****	*****	*****	*****	-0.4886
-0.950	*****	0.3489	0.3157	0.2252	-0.4403	*****	*****	*****	*****	-0.4403
-0.975	0.2343	0.2584	0.2478	0.1964	-0.1403	*****	*****	*****	*****	-0.1403
-1.000	*****	0.0930	0.1175	0.1001	-0.0576	*****	*****	*****	*****	-0.0576
-1.000	-1.3181	-1.1078	-0.9403	-0.9424	-0.4983	*****	*****	*****	*****	-0.4983

Medium Radius L.E.
 Run No. = 14, Point No. = 300
 $C_N = 0.809$, $C_m = -0.1396$
 $\alpha = 16.3^\circ$, $M_\infty = 0.851$
 $R_{mac} = 61.0 \times 10^6$

Leading Edge Pressures

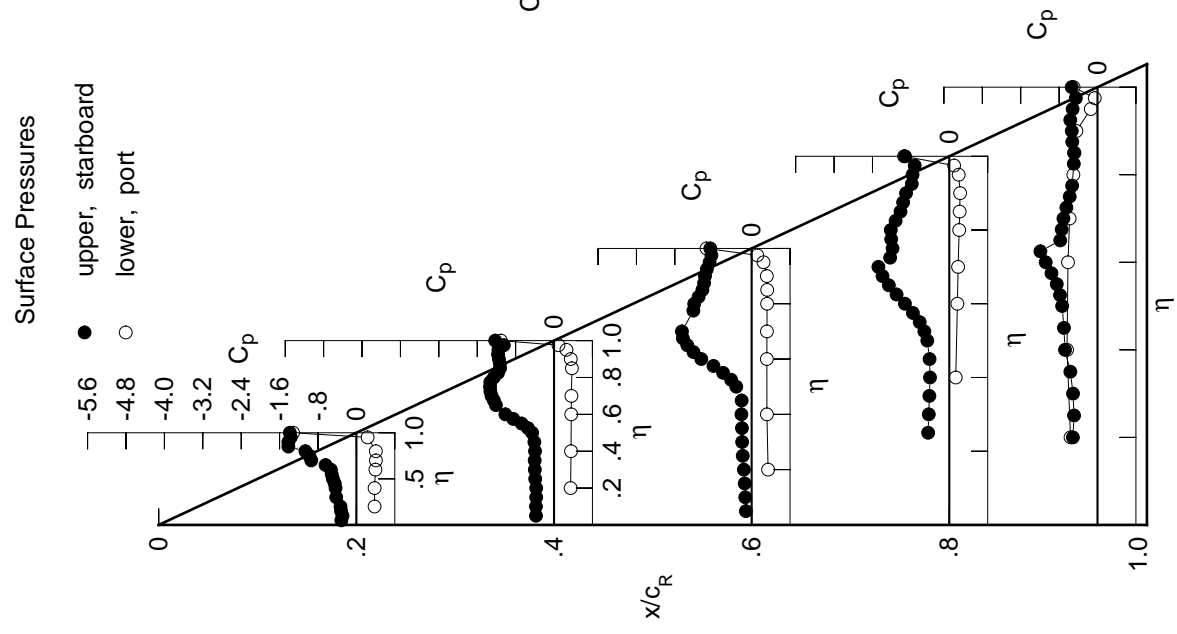
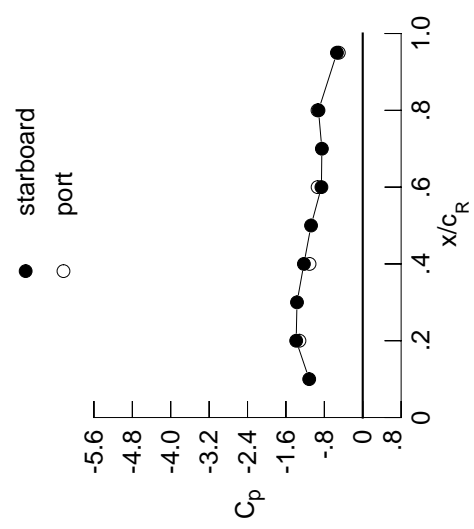

x/c_R	starb'd C_p	port C_p
0.10	-1.1154	*****
0.20	-1.3866	-1.3181
0.30	-1.3695	*****
0.40	-1.2257	-1.1078
0.50	-1.0770	*****
0.60	-0.8606	-0.9403
0.70	-0.8515	*****
0.80	-0.9217	-0.9424
0.90	-0.0542	*****
0.95	-0.5372	-0.4983

Table E6. Continued.

η	x/c_R .2	x/c_R .4	x/c_R .6	x/c_R .8	x/c_R .95
	$C_{p,u}$	$C_{p,u}$	$C_{p,u}$	$C_{p,u}$	$C_{p,u}$
0.050	-0.3875	-0.4284	-0.0943	*****	*****
0.100	-0.3584	-0.4265	-0.1054	*****	*****
0.150	-0.3781	-0.4224	-0.1179	*****	*****
0.200	-0.4117	-0.4227	-0.1281	*****	-0.6372
0.250	*****	-0.4454	-0.1573	-0.2207	-0.6509
0.300	-0.4380	-0.4604	-0.1736	-0.1880	-0.6502
0.350	*****	-0.4727	-0.1998	-0.1836	-0.6768
0.400	-0.5192	-0.4782	-0.2359	-0.1547	-0.7143
0.450	-0.5362	-0.5135	-0.2863	-0.1811	-0.7381
0.500	-0.5378	-0.6098	-0.4968	-0.2779	-0.7014
0.525	*****	-0.7314	-0.6575	-0.3637	-0.7101
0.550	-0.5501	-0.8945	-0.8366	-0.4700	-0.6779
0.575	*****	-1.0816	-1.0217	-0.6006	-0.6877
0.600	-0.7021	-1.2630	-1.2206	-0.7172	-0.6779
0.625	*****	*****	-1.3341	-0.7771	-0.6809
0.650	-1.1944	-1.5280	-1.4410	-0.7357	-0.6833
0.675	*****	-1.5911	-1.5257	-0.6515	-0.6621
0.700	-1.3525	-1.5961	-1.4413	-0.6228	-0.6557
0.725	*****	-1.4845	*****	-0.5820	-0.6492
0.750	-1.3242	-1.4727	*****	-0.5385	-0.6357
0.775	*****	-1.4818	-1.1843	-0.5211	-0.6201
0.800	-1.4144	-1.3339	-1.1404	-0.5168	*****
0.825	*****	-1.2403	-1.1170	-0.5177	-0.5879
0.850	-1.4459	-1.1828	-1.0717	-0.5383	-0.5683
0.875	*****	-1.1550	-1.0157	-0.5393	-0.5528
0.900	-1.3540	-1.1351	-0.9314	-0.5351	-0.5328
0.925	*****	-1.1161	-0.8676	-0.5335	-0.5233
0.950	-1.3166	-1.1038	-0.8357	-0.5420	-0.4719
0.975	*****	-1.0203	-0.8133	-0.5335	-0.4351
1.000	-1.4330	-1.1553	-0.8167	-0.6778	-0.5346
	$C_{p,l}$	$C_{p,l}$	$C_{p,l}$	$C_{p,l}$	$C_{p,l}$
-0.200	0.4368	0.3935	0.3765	*****	-0.5680
-0.400	0.4381	0.4007	0.3540	0.1581	-0.6330
-0.600	0.4530	0.4056	0.3501	0.1928	-0.6057
-0.700	0.4576	0.4065	0.3521	0.2078	-0.5687
-0.800	0.4467	*****	0.3525	0.2280	-0.4867
-0.850	*****	0.4025	0.3510	0.2364	-0.4675
-0.900	*****	0.3664	0.3314	0.2403	-0.4143
-0.950	0.2268	0.2522	0.2405	0.1920	-0.1258
-0.975	*****	0.0612	0.0861	0.0746	-0.0556
-1.000	-1.3753	-1.1008	-0.9331	-0.9561	-0.4096

Medium Radius L.E.
 Run No. = 14, Point No. = 301
 $C_N = 0.842$, $C_m = -0.1271$
 $\alpha = 18.4^\circ$, $M_\infty = 0.850$
 $R_{mac} = 61.0 \times 10^6$

Leading Edge Pressures

● starboard
 ○ port

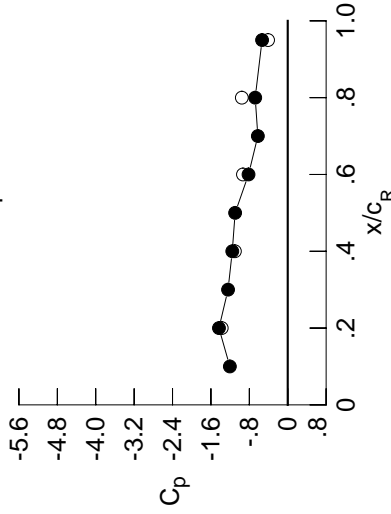

x/c_R	starb'd C_p	port C_p
0.10	-1.2059	*****
0.20	-1.4330	-1.3753
0.30	-1.2434	*****
0.40	-1.1553	-1.1008
0.50	-1.0958	*****
0.60	-0.8167	-0.9331
0.70	-0.6223	*****
0.80	-0.6778	-0.9561
0.90	-0.0060	*****
0.95	-0.5346	-0.4096

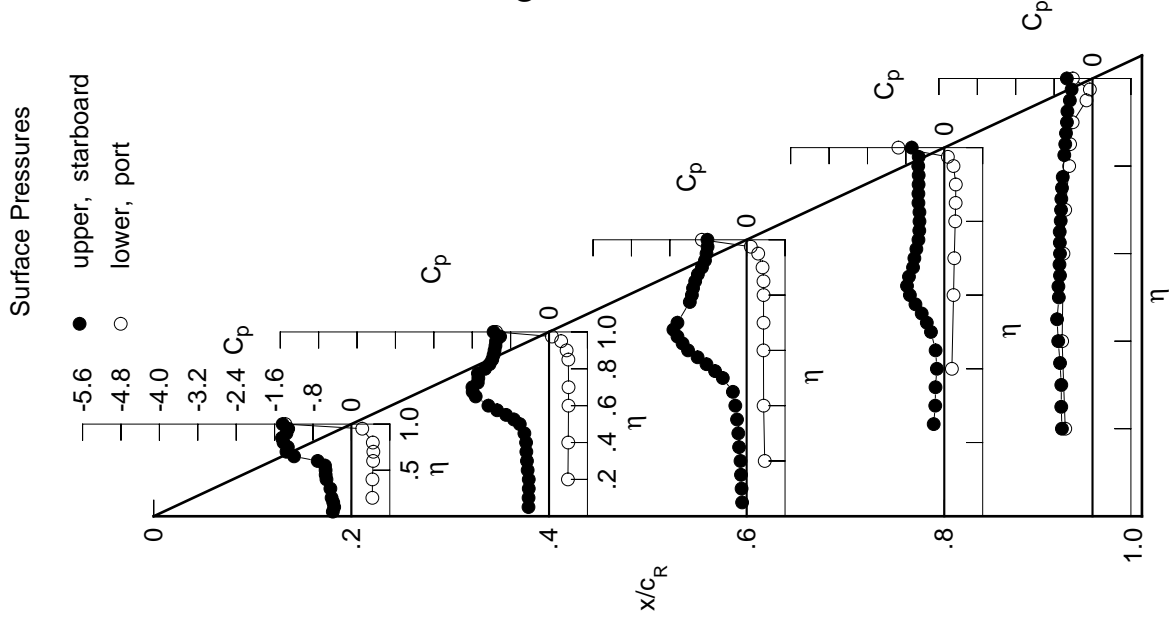

Table E6. Continued.

η	$x/c_R = 0.2$		$x/c_R = 0.4$		$x/c_R = 0.6$		$x/c_R = 0.8$		$x/c_R = 0.95$	
	$C_{p,u}$	$C_{p,u}$	$C_{p,u}$	$C_{p,u}$	$C_{p,u}$	$C_{p,u}$	$C_{p,u}$	$C_{p,u}$	$C_{p,u}$	$C_{p,u}$
0.050	-0.4247	-0.5127	-0.0806	*****	*****	*****	*****	*****	*****	*****
0.100	-0.3925	-0.5092	-0.0900	*****	*****	*****	*****	*****	*****	*****
0.150	-0.4508	-0.5091	-0.1001	*****	*****	*****	*****	*****	*****	*****
0.200	-0.4644	-0.5269	-0.1116	*****	*****	*****	*****	*****	*****	-0.5483
0.250	*****	-0.5279	-0.1326	-0.4805	-0.4805	-0.5281	*****	*****	*****	*****
0.300	-0.4600	-0.5332	-0.1473	-0.4957	-0.5514	*****	*****	*****	*****	*****
0.350	*****	-0.5504	-0.1880	-0.5461	-0.6038	*****	*****	*****	*****	*****
0.400	-0.4861	-0.5913	-0.2740	-0.5989	-0.6803	*****	*****	*****	*****	*****
0.450	-0.5028	-0.7232	-0.4025	-0.6984	-0.7321	*****	*****	*****	*****	*****
0.500	-0.5862	-0.9585	-0.7062	-0.7976	-0.7137	*****	*****	*****	*****	*****
0.525	*****	-1.1134	-0.8800	-0.8337	-0.7270	*****	*****	*****	*****	*****
0.550	-0.9938	-1.2742	-1.0377	-0.8586	-0.7032	*****	*****	*****	*****	*****
0.575	*****	-1.4017	-1.1869	-0.8738	-0.7164	*****	*****	*****	*****	*****
0.600	-1.4657	-1.5015	-1.3387	-0.8856	-0.7042	*****	*****	*****	*****	*****
0.625	*****	*****	-1.4216	-0.8777	-0.7007	*****	*****	*****	*****	*****
0.650	-1.6485	-1.6489	-1.4238	-0.8640	-0.6986	*****	*****	*****	*****	*****
0.675	*****	-1.6909	-1.2138	-0.8463	-0.6841	*****	*****	*****	*****	*****
0.700	-1.4417	-1.6562	-1.1581	-0.8086	-0.6761	*****	*****	*****	*****	*****
0.725	*****	-1.5399	*****	-0.7788	-0.6677	*****	*****	*****	*****	*****
0.750	-1.3883	-1.4951	*****	-0.7397	-0.6515	*****	*****	*****	*****	*****
0.775	*****	-1.4279	-1.0854	-0.7290	-0.6373	*****	*****	*****	*****	*****
0.800	-1.4567	-1.3465	-1.1265	-0.7313	*****	*****	*****	*****	*****	*****
0.825	*****	-1.2825	-1.2010	-0.7196	-0.5929	*****	*****	*****	*****	*****
0.850	-1.4582	-1.2534	-1.0976	-0.7441	-0.5724	*****	*****	*****	*****	*****
0.875	*****	-1.2275	-0.9228	-0.7614	-0.5484	*****	*****	*****	*****	*****
0.900	-1.3017	-1.1866	-0.8163	-0.7965	-0.5152	*****	*****	*****	*****	*****
0.925	*****	-1.1569	-0.7888	-0.8377	-0.4859	*****	*****	*****	*****	*****
0.950	-1.2713	-1.1554	-0.7678	-0.8730	-0.4392	*****	*****	*****	*****	*****
0.975	*****	-1.1156	-0.7349	-0.8321	-0.3985	*****	*****	*****	*****	*****
1.000	-1.4308	-1.2079	-0.7137	-0.9377	-0.4200	*****	*****	*****	*****	*****
-0.200	$C_{p,l}$	$C_{p,l}$	$C_{p,l}$	$C_{p,l}$	$C_{p,l}$	$C_{p,l}$	$C_{p,l}$	$C_{p,l}$	$C_{p,l}$	$C_{p,l}$
-0.400	0.4918	0.4397	0.4113	*****	*****	*****	*****	*****	*****	-0.5435
-0.600	0.4936	0.4459	0.3882	0.1887	0.1887	0.1887	0.1887	0.1887	0.1887	-0.6094
-0.700	0.5042	0.4467	0.3845	0.2215	0.2215	0.2215	0.2215	0.2215	0.2215	-0.5838
-0.800	0.5027	0.4471	0.3833	0.2340	0.2340	0.2340	0.2340	0.2340	0.2340	-0.5449
-0.850	0.4806	*****	0.3794	0.2531	0.2531	0.2531	0.2531	0.2531	0.2531	-0.4624
-0.900	*****	0.4270	0.3715	0.2570	0.2570	0.2570	0.2570	0.2570	0.2570	-0.4426
-0.950	*****	0.3765	0.3392	0.2518	0.2518	0.2518	0.2518	0.2518	0.2518	-0.3884
-0.975	0.2132	0.2377	0.2200	0.1796	0.1796	0.1796	0.1796	0.1796	0.1796	-0.1238
-1.000	*****	0.0218	0.0375	0.0346	0.0346	0.0346	0.0346	0.0346	0.0346	-0.0792
-1.000	-1.3562	-1.1498	-1.0702	-1.0305	-0.4364	*****	*****	*****	*****	*****

Medium Radius L.E.
 Run No. = 14, Point No. = 302
 $C_N = 0.970$, $C_m = -0.1607$
 $\alpha = 20.4^\circ$, $M_\infty = 0.852$
 $R_{mac} = 60.8 \times 10^6$

Leading Edge Pressures

● starboard
 ○ port

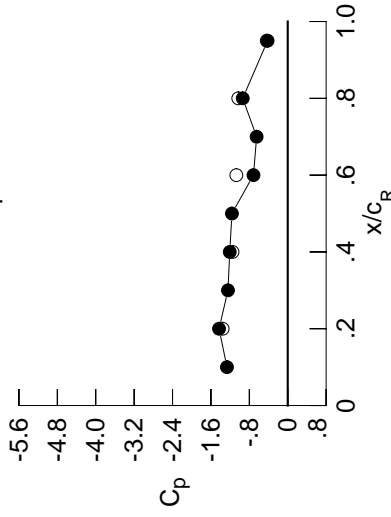

x/c_R	starb'd C_p	port C_p
0.10	-1.2661	*****
0.20	-1.4308	-1.3562
0.30	-1.2452	*****
0.40	-1.2079	-1.1498
0.50	-1.1624	*****
0.60	-0.7137	-1.0702
0.70	-0.6480	*****
0.80	-0.9377	-1.0305
0.90	-0.0094	*****
0.95	-0.4200	-0.4364

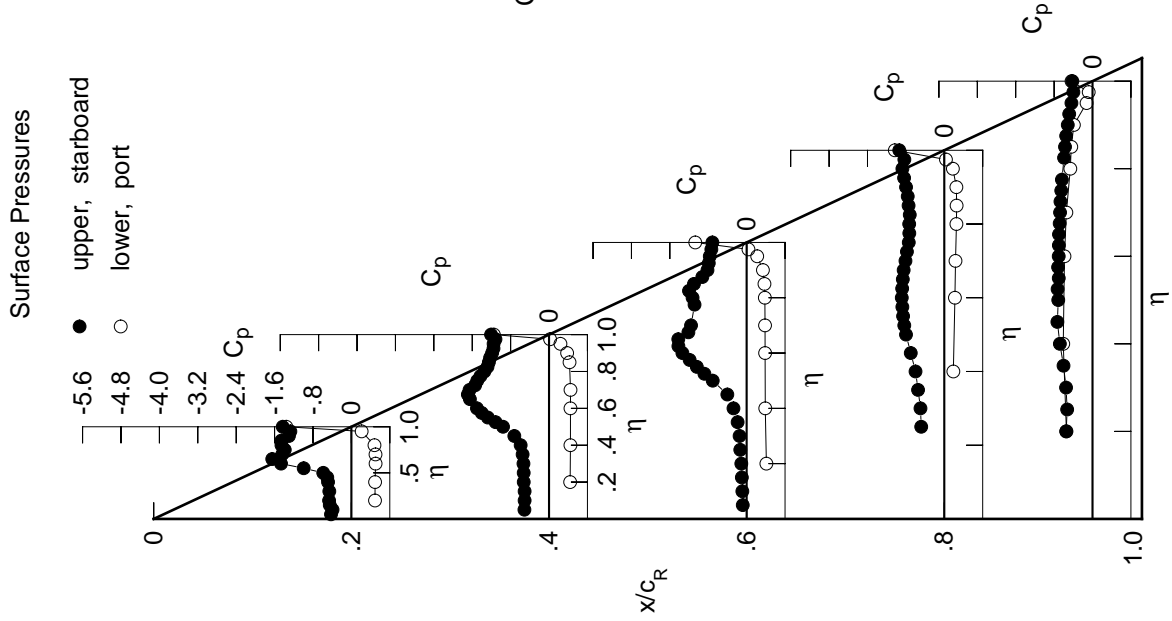

Table E6. Continued.

η	$x/c_R = .2$		$x/c_R = .4$		$x/c_R = .6$		$x/c_R = .8$		$x/c_R = .95$	
	$C_{p,u}$	$C_{p,u}$	$C_{p,u}$	$C_{p,u}$	$C_{p,u}$	$C_{p,u}$	$C_{p,u}$	$C_{p,u}$	$C_{p,u}$	$C_{p,u}$
0.050	-0.5068	-0.5864	-0.1174	*****	*****	*****	*****	*****	*****	*****
0.100	-0.4644	-0.5845	-0.1221	*****	*****	*****	*****	*****	*****	*****
0.150	-0.5352	-0.5762	-0.1277	*****	*****	*****	*****	*****	*****	*****
0.200	-0.5351	-0.6010	-0.1325	*****	*****	*****	*****	*****	*****	*****
0.250	*****	-0.6022	-0.1572	-0.6942	-0.5894	*****	*****	*****	*****	*****
0.300	-0.5365	-0.6270	-0.2056	-0.7290	-0.6453	*****	*****	*****	*****	*****
0.350	*****	-0.6779	-0.2813	-0.7992	-0.7125	*****	*****	*****	*****	*****
0.400	-0.5753	-0.7758	-0.4169	-0.8527	-0.7784	*****	*****	*****	*****	*****
0.450	-0.6691	-0.9636	-0.5955	-0.9133	-0.7932	*****	*****	*****	*****	*****
0.500	-0.9782	-1.1882	-0.9200	-0.9399	-0.7497	*****	*****	*****	*****	*****
0.525	*****	-1.3092	-1.0720	-0.9434	-0.7630	*****	*****	*****	*****	*****
0.550	-1.4239	-1.4393	-1.1994	-0.9400	-0.7410	*****	*****	*****	*****	*****
0.575	*****	-1.5335	-1.3181	-0.9538	-0.7544	*****	*****	*****	*****	*****
0.600	-1.6898	-1.6154	-1.4411	-0.9742	-0.7439	*****	*****	*****	*****	*****
0.625	*****	*****	-1.3435	-0.9718	-0.7476	*****	*****	*****	*****	*****
0.650	-1.8043	-1.5589	-1.1385	-0.9437	-0.7458	*****	*****	*****	*****	*****
0.675	*****	-1.4950	-1.0799	-0.9206	-0.7273	*****	*****	*****	*****	*****
0.700	-1.6491	-1.4732	-1.0476	-0.8977	-0.7159	*****	*****	*****	*****	*****
0.725	*****	-1.4602	*****	-0.8759	-0.7047	*****	*****	*****	*****	*****
0.750	-1.4499	-1.4593	*****	-0.8428	-0.6843	*****	*****	*****	*****	*****
0.775	*****	-1.4812	-1.0141	-0.8353	-0.6654	*****	*****	*****	*****	*****
0.800	-1.4510	-1.5128	-1.0501	-0.8315	*****	*****	*****	*****	*****	*****
0.825	*****	-1.4517	-1.0506	-0.8238	-0.6111	*****	*****	*****	*****	*****
0.850	-1.4363	-1.3254	-0.9486	-0.8328	-0.5897	*****	*****	*****	*****	*****
0.875	*****	-1.2700	-0.8585	-0.8311	-0.5666	*****	*****	*****	*****	*****
0.900	-1.3273	-1.2709	-0.8102	-0.8303	-0.5387	*****	*****	*****	*****	*****
0.925	*****	-1.2668	-0.7962	-0.8274	-0.5190	*****	*****	*****	*****	*****
0.950	-1.2960	-1.2896	-0.7739	-0.8264	-0.4757	*****	*****	*****	*****	*****
0.975	*****	-1.2541	-0.7259	-0.8036	-0.4385	*****	*****	*****	*****	*****
1.000	-1.4591	-1.3049	-0.6735	-0.8398	-0.4413	*****	*****	*****	*****	*****
-0.200	$C_{p,l}$	0.4879	0.4498	*****	*****	*****	*****	*****	*****	*****
-0.400	0.5497	0.4931	0.4256	0.2227	-0.5857	*****	*****	*****	*****	*****
-0.600	0.5557	0.4911	0.4220	0.2524	-0.5589	*****	*****	*****	*****	*****
-0.700	0.5473	0.4881	0.4184	0.2649	-0.5185	*****	*****	*****	*****	*****
-0.800	0.5130	*****	0.4094	0.2799	-0.4355	*****	*****	*****	*****	*****
-0.850	*****	0.4511	0.3960	0.2800	-0.4145	*****	*****	*****	*****	*****
-0.900	*****	0.3864	0.3515	0.2657	-0.3604	*****	*****	*****	*****	*****
-0.950	0.1987	0.2234	0.2071	0.1719	-0.1151	*****	*****	*****	*****	*****
-0.975	*****	-0.0160	0.0020	0.0043	-0.0922	*****	*****	*****	*****	*****
-1.000	-1.3685	-1.2431	-1.1758	-1.0610	-0.4413	*****	*****	*****	*****	*****

Medium Radius L.E.
 Run No. = 14, Point No. = 303
 $C_N = 1.079$, $C_m = -0.1798$
 $\alpha = 22.5^\circ$, $M_\infty = 0.851$
 $R_{mac} = 60.3 \times 10^6$

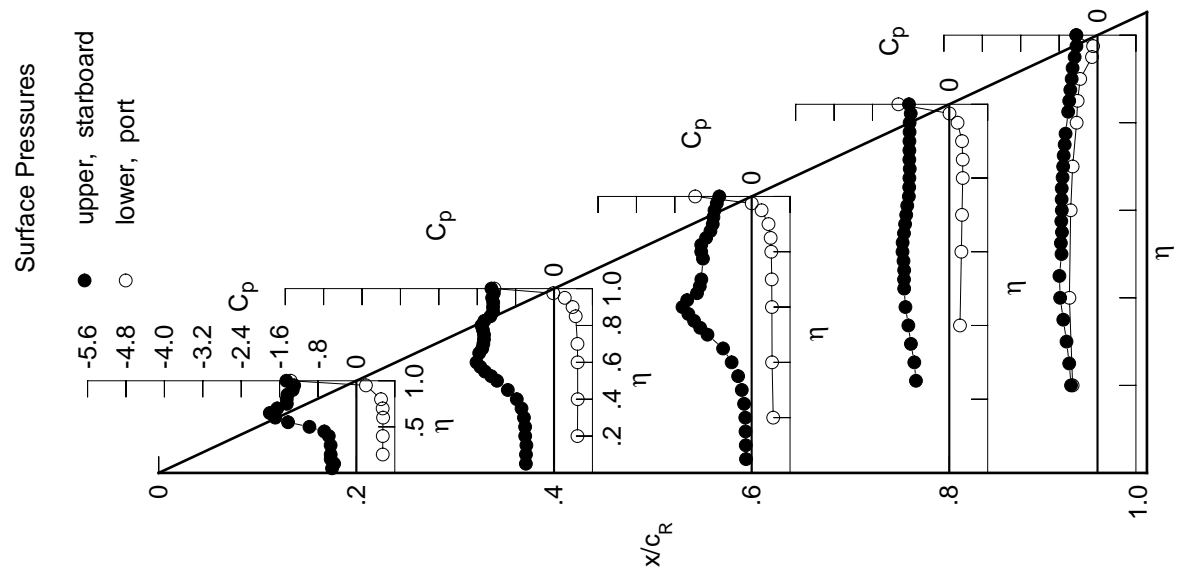
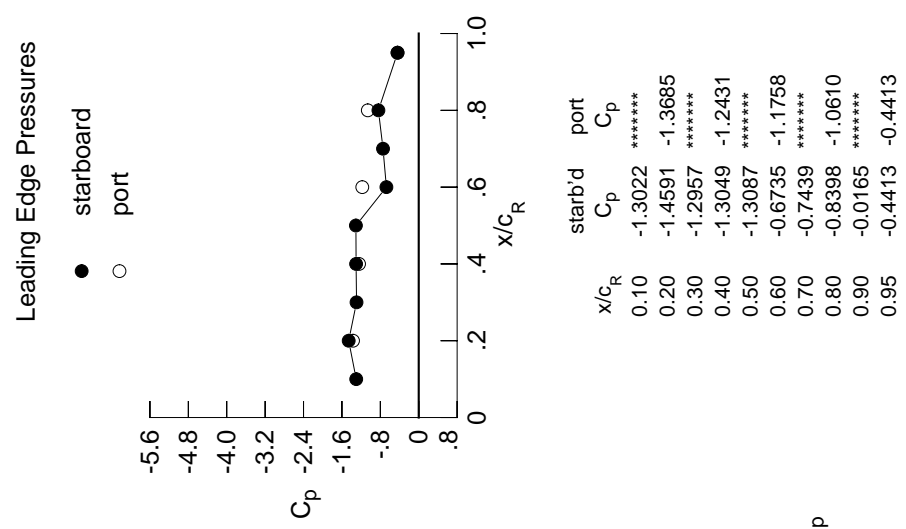
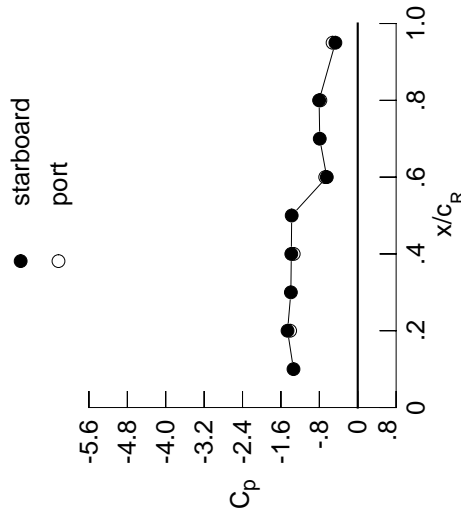

Table E6. Continued.

η	$x/c_R = .2$		$x/c_R = .4$		$x/c_R = .6$		$x/c_R = .8$		$x/c_R = .95$	
	$C_{p,u}$	$C_{p,u}$	$C_{p,u}$	$C_{p,u}$	$C_{p,u}$	$C_{p,u}$	$C_{p,u}$	$C_{p,u}$	$C_{p,u}$	$C_{p,u}$
0.050	-0.5880	-0.6518	-0.0139	*****	*****	*****	*****	*****	*****	*****
0.100	-0.5529	-0.6526	-0.0268	*****	*****	*****	*****	*****	*****	*****
0.150	-0.5963	-0.6545	-0.0449	*****	*****	*****	*****	*****	*****	*****
0.200	-0.6141	-0.6647	-0.0629	*****	*****	*****	*****	*****	*****	-0.5659
0.250	*****	-0.6957	-0.1086	-0.8158	-0.8158	-0.8158	-0.8158	-0.8158	-0.8158	-0.6162
0.300	-0.6476	-0.7416	-0.1737	-0.8600	-0.8600	-0.8600	-0.8600	-0.8600	-0.8600	-0.6868
0.350	*****	-0.8287	-0.2896	-0.9248	-0.9248	-0.9248	-0.9248	-0.9248	-0.9248	-0.7507
0.400	-0.7679	-0.9612	-0.4750	-0.9777	-0.9777	-0.9777	-0.9777	-0.9777	-0.9777	-0.8408
0.450	-0.9866	-1.1521	-0.6986	-1.0222	-1.0222	-1.0222	-1.0222	-1.0222	-1.0222	-0.8720
0.500	-1.3202	-1.3414	-1.0001	-1.0150	-1.0150	-1.0150	-1.0150	-1.0150	-1.0150	-0.8187
0.525	*****	-1.4377	-1.1335	-1.0018	-1.0018	-1.0018	-1.0018	-1.0018	-1.0018	-0.8126
0.550	-1.5933	-1.5451	-1.2480	-0.9684	-0.9684	-0.9684	-0.9684	-0.9684	-0.9684	-0.7792
0.575	*****	-1.6186	-1.3485	-0.9630	-0.9630	-0.9630	-0.9630	-0.9630	-0.9630	-0.7830
0.600	-1.7538	-1.6819	-1.4460	-0.9654	-0.9654	-0.9654	-0.9654	-0.9654	-0.9654	-0.7773
0.625	*****	*****	-1.3808	-0.9701	-0.9701	-0.9701	-0.9701	-0.9701	-0.9701	-0.7797
0.650	-1.6932	-1.5318	-1.1883	-0.9700	-0.9700	-0.9700	-0.9700	-0.9700	-0.9700	-0.7731
0.675	*****	-1.4660	-1.1107	-0.9640	-0.9640	-0.9640	-0.9640	-0.9640	-0.9640	-0.7571
0.700	-1.6834	-1.4693	-1.0552	-0.9458	-0.9458	-0.9458	-0.9458	-0.9458	-0.9458	-0.7497
0.725	*****	-1.4756	*****	-0.9359	-0.9359	-0.9359	-0.9359	-0.9359	-0.9359	-0.7411
0.750	-1.6273	-1.4726	*****	-0.9074	-0.9074	-0.9074	-0.9074	-0.9074	-0.9074	-0.7248
0.775	*****	-1.5103	-0.9662	-0.8994	-0.8994	-0.8994	-0.8994	-0.8994	-0.8994	-0.7076
0.800	-1.4284	-1.5312	-0.9448	-0.8905	-0.8905	-0.8905	-0.8905	-0.8905	-0.8905	*****
0.825	*****	-1.4621	-0.9502	-0.8821	-0.8821	-0.8821	-0.8821	-0.8821	-0.8821	-0.6576
0.850	-1.4289	-1.3912	-0.9065	-0.8809	-0.8809	-0.8809	-0.8809	-0.8809	-0.8809	-0.6375
0.875	*****	-1.3608	-0.8481	-0.8687	-0.8687	-0.8687	-0.8687	-0.8687	-0.8687	-0.6141
0.900	-1.3581	-1.3584	-0.7895	-0.8552	-0.8552	-0.8552	-0.8552	-0.8552	-0.8552	-0.5868
0.925	*****	-1.3635	-0.7466	-0.8358	-0.8358	-0.8358	-0.8358	-0.8358	-0.8358	-0.5720
0.950	-1.3351	-1.3713	-0.7155	-0.8226	-0.8226	-0.8226	-0.8226	-0.8226	-0.8226	-0.5212
0.975	*****	-1.3472	-0.6889	-0.8039	-0.8039	-0.8039	-0.8039	-0.8039	-0.8039	-0.4796
1.000	-1.4620	-1.3839	-0.6450	-0.8046	-0.8046	-0.8046	-0.8046	-0.8046	-0.8046	-0.4655
	$C_{p,l}$	$C_{p,l}$	$C_{p,l}$	$C_{p,l}$	$C_{p,l}$	$C_{p,l}$	$C_{p,l}$	$C_{p,l}$	$C_{p,l}$	$C_{p,l}$
-0.200	0.6026	0.5354	0.4862	*****	*****	*****	*****	*****	*****	-0.5067
-0.400	0.6034	0.5380	0.4648	0.2518	0.2518	0.2518	0.2518	0.2518	0.2518	-0.5720
-0.600	0.6043	0.5342	0.4594	0.2808	0.2808	0.2808	0.2808	0.2808	0.2808	-0.5473
-0.700	0.5895	0.5286	0.4566	0.2906	0.2906	0.2906	0.2906	0.2906	0.2906	-0.5070
-0.800	0.5425	*****	0.4455	0.3039	0.3039	0.3039	0.3039	0.3039	0.3039	-0.4287
-0.850	*****	0.4753	0.4285	0.3018	0.3018	0.3018	0.3018	0.3018	0.3018	-0.4120
-0.900	*****	0.3970	0.3783	0.2838	0.2838	0.2838	0.2838	0.2838	0.2838	-0.3639
-0.950	0.1836	0.2119	0.2244	0.1826	0.1826	0.1826	0.1826	0.1826	0.1826	-0.1364
-0.975	*****	-0.0472	0.0164	0.0125	0.0125	0.0125	0.0125	0.0125	0.0125	-0.1336
-1.000	-1.4083	-1.3337	-0.6775	-0.7787	-0.7787	-0.7787	-0.7787	-0.7787	-0.7787	-0.5242

Medium Radius L.E.
 Run No. = 14 , Point No. = 304
 $C_N = 1.117$, $C_m = -0.1763$
 $\alpha = 24.5^\circ$, $M_\infty = 0.851$
 $R_{mac} = 59.4 \times 10^6$

Leading Edge Pressures



x/c_R	starb'd C_p	port C_p
0.10	-1.3388	*****
0.20	-1.4620	-1.4083
0.30	-1.3932	*****
0.40	-1.3839	-1.3337
0.50	-1.3757	*****
0.60	-0.6450	-0.6775
0.70	-0.7915	*****
0.80	-0.8046	-0.7787
0.90	-0.0078	*****
0.95	-0.4655	-0.5242

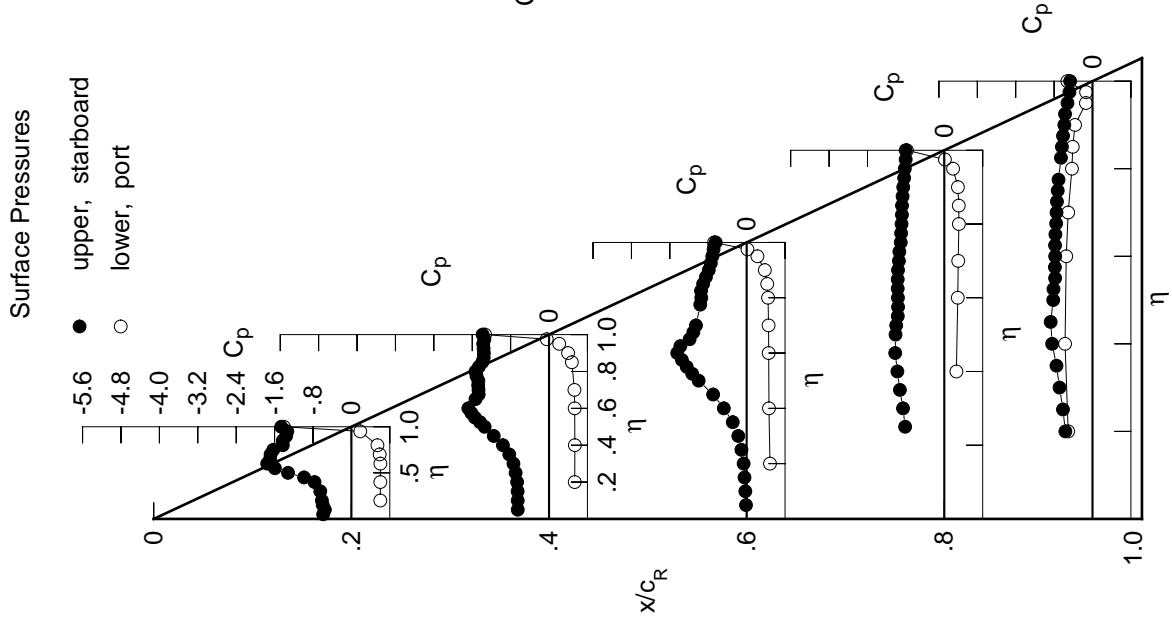
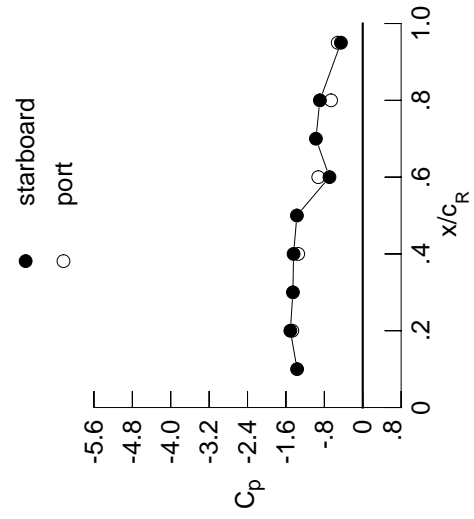

Table E6. Continued.

η	$x/c_R = .2$		$x/c_R = .4$		$x/c_R = .6$		$x/c_R = .8$		$x/c_R = .95$	
	$C_{p,u}$	$C_{p,u}$	$C_{p,u}$	$C_{p,u}$	$C_{p,u}$	$C_{p,u}$	$C_{p,u}$	$C_{p,u}$	$C_{p,u}$	$C_{p,u}$
0.050	-0.6745	-0.7088	-0.4029	*****	*****	*****	*****	*****	*****	
0.100	-0.6435	-0.7241	-0.3846	*****	*****	*****	*****	*****	*****	
0.150	-0.6806	-0.7440	-0.3706	*****	*****	*****	*****	*****	*****	
0.200	-0.6980	-0.7631	-0.3595	*****	*****	*****	*****	*****	-0.5588	
0.250	*****	-0.8044	-0.3818	-1.0192	-0.6503	*****	*****	*****	*****	
0.300	-0.7620	-0.8668	-0.4164	-1.0767	-0.7540	*****	*****	*****	*****	
0.350	*****	-0.9683	-0.5085	-1.1406	-0.8416	*****	*****	*****	*****	
0.400	-1.0252	-1.1109	-0.6601	-1.1829	-0.9101	*****	*****	*****	*****	
0.450	-1.2822	-1.2944	-0.8371	-1.1882	-0.8761	*****	*****	*****	*****	
0.500	-1.5299	-1.4521	-1.0884	-1.1124	-0.7844	*****	*****	*****	*****	
0.525	*****	-1.5301	-1.2013	-1.0615	-0.7740	*****	*****	*****	*****	
0.550	-1.7018	-1.6177	-1.2907	-1.0021	-0.7528	*****	*****	*****	*****	
0.575	*****	-1.6751	-1.3672	-0.9895	-0.7715	*****	*****	*****	*****	
0.600	-1.7997	-1.6942	-1.3839	-1.0017	-0.7832	*****	*****	*****	*****	
0.625	*****	*****	-1.2908	-1.0099	-0.8029	*****	*****	*****	*****	
0.650	-1.6689	-1.5355	-1.1625	-1.0104	-0.8044	*****	*****	*****	*****	
0.675	*****	-1.5013	-1.0978	-1.0237	-0.7826	*****	*****	*****	*****	
0.700	-1.6908	-1.5077	-1.0451	-1.0296	-0.7657	*****	*****	*****	*****	
0.725	*****	-1.5189	*****	-1.0365	-0.7493	*****	*****	*****	*****	
0.750	-1.6833	-1.5268	*****	-1.0172	-0.7283	*****	*****	*****	*****	
0.775	*****	-1.5648	-0.9601	-1.0170	-0.7112	*****	*****	*****	*****	
0.800	-1.4557	-1.5789	-0.9500	-1.0090	*****	*****	*****	*****	*****	
0.825	*****	-1.5244	-0.9548	-1.0105	-0.6531	*****	*****	*****	*****	
0.850	-1.4534	-1.4570	-0.9439	-1.0116	-0.6295	*****	*****	*****	*****	
0.875	*****	-1.4179	-0.9161	-0.9997	-0.6046	*****	*****	*****	*****	
0.900	-1.3994	-1.4117	-0.8578	-0.9857	-0.5783	*****	*****	*****	*****	
0.925	*****	-1.4243	-0.7988	-0.9597	-0.5611	*****	*****	*****	*****	
0.950	-1.3966	-1.4263	-0.7606	-0.9336	-0.5208	*****	*****	*****	*****	
0.975	*****	-1.4119	-0.7395	-0.9091	-0.4814	*****	*****	*****	*****	
1.000	-1.5079	-1.4411	-0.6925	-0.8928	-0.4542	*****	*****	*****	*****	
	$C_{p,l}$	$C_{p,l}$	$C_{p,l}$	$C_{p,l}$	$C_{p,l}$	$C_{p,l}$	$C_{p,l}$	$C_{p,l}$	$C_{p,l}$	
-0.200	0.6592	0.5832	0.5253	*****	-0.4843	*****	*****	*****	*****	
-0.400	0.6581	0.5871	0.5042	0.2865	-0.5458	*****	*****	*****	*****	
-0.600	0.6527	0.5794	0.4961	0.3143	-0.5190	*****	*****	*****	*****	
-0.700	0.6314	0.5702	0.4914	0.3229	-0.4801	*****	*****	*****	*****	
-0.800	0.5701	*****	0.4730	0.3330	-0.4016	*****	*****	*****	*****	
-0.850	*****	0.5000	0.4493	0.3279	-0.3861	*****	*****	*****	*****	
-0.900	*****	0.4084	0.3861	0.3038	-0.3388	*****	*****	*****	*****	
-0.950	0.1682	0.2025	0.2081	0.1859	-0.1269	*****	*****	*****	*****	
-0.975	*****	-0.0740	-0.0238	0.0016	-0.1394	*****	*****	*****	*****	
-1.000	-1.4675	-1.3440	-0.9266	-0.6594	-0.5210	*****	*****	*****	*****	

Medium Radius L.E.
 Run No. = 14, Point No. = 305
 $C_N = 1.191$, $C_m = -0.1846$
 $\alpha = 26.6^\circ$, $M_\infty = 0.851$
 $R_{mac} = 58.9 \times 10^6$

Leading Edge Pressures



x/c_R	starb'd C_p	port C_p
0.10	-1.3673	*****
0.20	-1.5079	-1.4675
0.30	-1.4548	*****
0.40	-1.4411	-1.3440
0.50	-1.3711	*****
0.60	-0.6925	-0.9266
0.70	-0.9760	*****
0.80	-0.8928	-0.6594
0.90	0.0016	*****
0.95	-0.4542	-0.5210

Surface Pressures

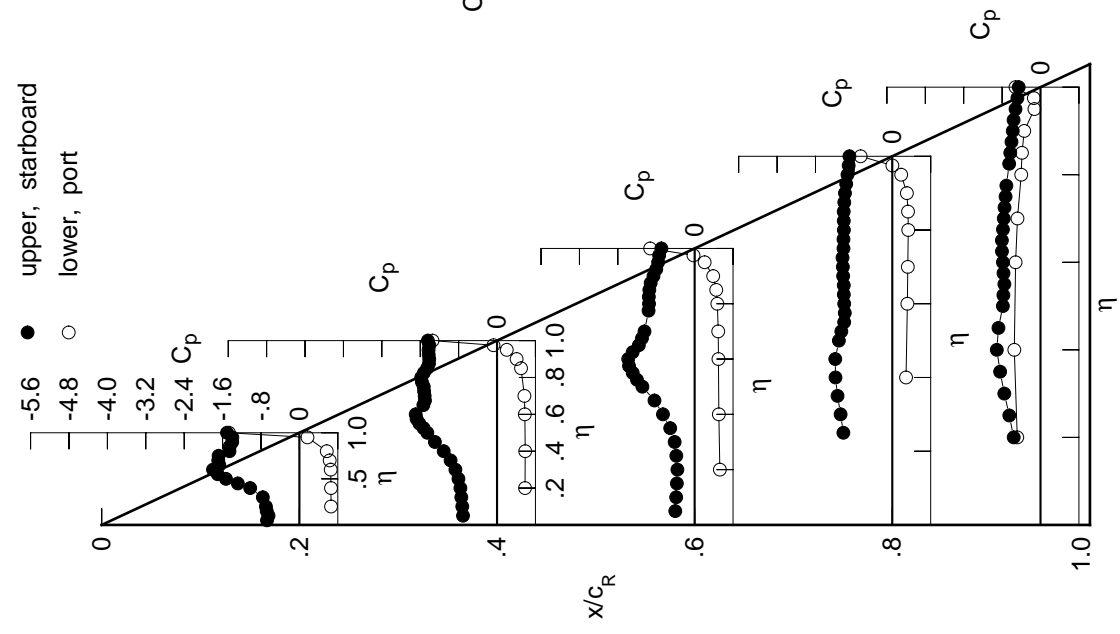
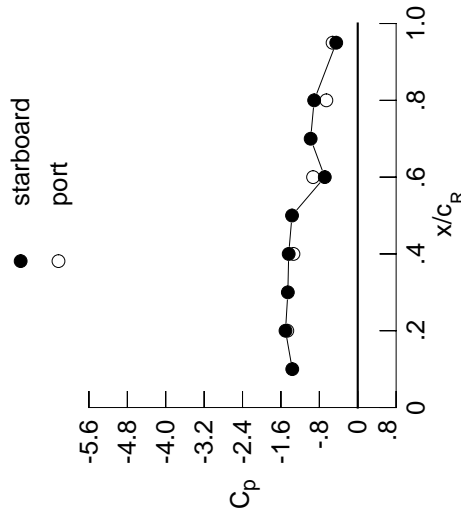

Table E6. Concluded.

η	$x/c_R = .2$		$x/c_R = .4$		$x/c_R = .6$		$x/c_R = .8$		$x/c_R = .95$	
	$C_{p,u}$	$C_{p,u}$	$C_{p,u}$	$C_{p,u}$	$C_{p,u}$	$C_{p,u}$	$C_{p,u}$	$C_{p,u}$	$C_{p,u}$	$C_{p,u}$
0.050	-0.6740	-0.7117	-0.4366	*****	*****	*****	*****	*****	*****	*****
0.100	-0.6434	-0.7255	-0.4200	*****	*****	*****	*****	*****	*****	*****
0.150	-0.6811	-0.7459	-0.4069	*****	*****	*****	*****	*****	*****	*****
0.200	-0.6979	-0.7626	-0.3924	*****	*****	*****	*****	*****	*****	*****
0.250	*****	-0.8059	-0.4153	-1.0158	-0.6300	*****	*****	*****	*****	*****
0.300	-0.7610	-0.8676	-0.4442	-1.0781	-0.7354	*****	*****	*****	*****	*****
0.350	*****	-0.9705	-0.5337	-1.1442	-0.8289	*****	*****	*****	*****	*****
0.400	-1.0240	-1.1136	-0.6812	-1.1883	-0.9235	*****	*****	*****	*****	*****
0.450	-1.2814	-1.2955	-0.8598	-1.2005	-0.9008	*****	*****	*****	*****	*****
0.500	-1.5286	-1.4528	-1.0980	-1.1368	-0.7975	*****	*****	*****	*****	*****
0.525	*****	-1.5284	-1.2067	-1.0819	-0.7772	*****	*****	*****	*****	*****
0.550	-1.6995	-1.6166	-1.2942	-1.0146	-0.7509	*****	*****	*****	*****	*****
0.575	*****	-1.6732	-1.3719	-0.9962	-0.7624	*****	*****	*****	*****	*****
0.600	-1.7932	-1.6871	-1.3796	-1.0082	-0.7718	*****	*****	*****	*****	*****
0.625	*****	*****	-1.2845	-1.0149	-0.7957	*****	*****	*****	*****	*****
0.650	-1.6634	-1.5344	-1.1627	-1.0171	-0.7994	*****	*****	*****	*****	*****
0.675	*****	-1.5024	-1.1080	-1.0228	-0.7817	*****	*****	*****	*****	*****
0.700	-1.6871	-1.5067	-1.0592	-1.0257	-0.7652	*****	*****	*****	*****	*****
0.725	*****	-1.5175	*****	-1.0342	-0.7497	*****	*****	*****	*****	*****
0.750	-1.6781	-1.5255	*****	-1.0194	-0.7296	*****	*****	*****	*****	*****
0.775	*****	-1.5634	-0.9739	-1.0215	-0.7120	*****	*****	*****	*****	*****
0.800	-1.4506	-1.5764	-0.9632	-1.0169	*****	*****	*****	*****	*****	*****
0.825	*****	-1.5207	-0.9630	-1.0210	-0.6502	*****	*****	*****	*****	*****
0.850	-1.4523	-1.4547	-0.9662	-1.0268	-0.6272	*****	*****	*****	*****	*****
0.875	*****	-1.4166	-0.9306	-1.0176	-0.6022	*****	*****	*****	*****	*****
0.900	-1.4051	-1.4110	-0.8646	-1.0035	-0.5752	*****	*****	*****	*****	*****
0.925	*****	-1.4232	-0.8018	-0.9737	-0.5568	*****	*****	*****	*****	*****
0.950	-1.3925	-1.4235	-0.7598	-0.9410	-0.5151	*****	*****	*****	*****	*****
0.975	*****	-1.4102	-0.7333	-0.9206	-0.4747	*****	*****	*****	*****	*****
1.000	-1.5047	-1.4383	-0.6862	-0.9080	-0.4476	*****	*****	*****	*****	*****
	$C_{p,l}$	$C_{p,l}$	$C_{p,l}$	$C_{p,l}$	$C_{p,l}$	$C_{p,l}$	$C_{p,l}$	$C_{p,l}$	$C_{p,l}$	$C_{p,l}$
-0.200	0.6595	0.5839	0.5254	*****	*****	*****	*****	*****	*****	*****
-0.400	0.6583	0.5865	0.5049	0.2872	-0.5442	*****	*****	*****	*****	*****
-0.600	0.6530	0.5796	0.4963	0.3137	-0.5181	*****	*****	*****	*****	*****
-0.700	0.6315	0.5702	0.4906	0.3237	-0.4788	*****	*****	*****	*****	*****
-0.800	0.5705	*****	0.4735	0.3337	-0.3997	*****	*****	*****	*****	*****
-0.850	*****	0.5009	0.4503	0.3289	-0.3854	*****	*****	*****	*****	*****
-0.900	*****	0.4091	0.3871	0.3043	-0.3383	*****	*****	*****	*****	*****
-0.950	0.1690	0.2043	0.2087	0.1876	-0.1264	*****	*****	*****	*****	*****
-0.975	*****	-0.0717	-0.0232	0.0038	-0.1392	*****	*****	*****	*****	*****
-1.000	-1.4670	-1.3391	-0.9302	-0.6539	-0.5241	*****	*****	*****	*****	*****

Medium Radius L.E.
 Run No. = 14, Point No. = 306
 $C_N = 1.186$, $C_m = -0.1832$
 $\alpha = 26.6^\circ$, $M_\infty = 0.852$
 $R_{mac} = 59.7 \times 10^6$

Leading Edge Pressures



x/c_R	starb'd C_p	port C_p
0.10	-1.3637	*****
0.20	-1.5047	-1.4670
0.30	-1.4557	*****
0.40	-1.4383	-1.3391
0.50	-1.3692	*****
0.60	-0.6862	-0.9302
0.70	-0.9812	*****
0.80	-0.9080	-0.6539
0.90	-0.0009	*****
0.95	-0.4476	-0.5241

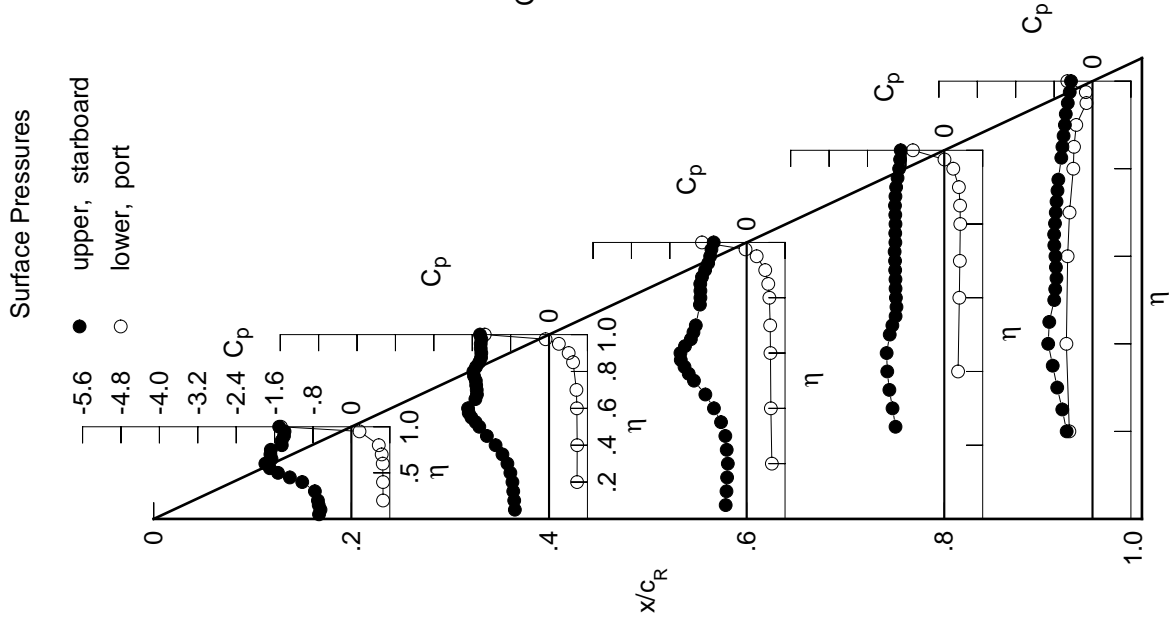

Table E7. Tabulations and Plots of Surface Pressure Coefficients.

η	$x/c_R = .2$		$x/c_R = .4$		$x/c_R = .6$		$x/c_R = .8$		$x/c_R = .95$	
	$C_{p,u}$	$C_{p,u}$	$C_{p,u}$	$C_{p,u}$	$C_{p,u}$	$C_{p,u}$	$C_{p,u}$	$C_{p,u}$	$C_{p,u}$	$C_{p,u}$
0.050	0.0035	0.0165	0.1398	0.1398	0.1398	0.1398	0.1398	0.1398	0.1398	0.1398
0.100	0.0069	0.0166	0.1301	0.1301	0.1301	0.1301	0.1301	0.1301	0.1301	0.1301
0.150	0.0028	0.0167	0.1182	0.1182	0.1182	0.1182	0.1182	0.1182	0.1182	0.1182
0.200	0.0022	0.0218	0.1064	0.1064	0.1064	0.1064	0.1064	0.1064	0.1064	0.1064
0.250	0.0000	0.0156	0.0926	0.0926	0.0926	0.0926	0.0926	0.0926	0.0926	0.0926
0.300	-0.0066	0.0170	0.0830	0.0830	0.1029	0.1029	0.1029	0.1029	0.1029	0.1029
0.350	0.0000	0.0136	0.0727	0.0727	0.0943	0.0943	0.0943	0.0943	0.0943	0.0943
0.400	-0.0204	0.0147	0.0670	0.0670	0.0806	0.0806	0.0806	0.0806	0.0806	0.0806
0.450	-0.0256	0.0115	0.0755	0.0755	0.0749	0.0749	0.0749	0.0749	0.0749	0.0749
0.500	-0.0312	0.0129	0.0491	0.0491	0.0684	0.0684	0.0684	0.0684	0.0684	0.0684
0.525	0.0000	0.0077	0.0472	0.0472	0.0685	0.0685	0.0685	0.0685	0.0685	0.0685
0.550	-0.0306	0.0016	0.0458	0.0458	0.0630	0.0630	0.0630	0.0630	0.0630	0.0630
0.575	0.0000	0.0007	0.0499	0.0499	0.0651	0.0651	0.0651	0.0651	0.0651	0.0651
0.600	-0.0372	0.0024	0.0343	0.0343	0.0633	0.0633	0.0633	0.0633	0.0633	0.0633
0.625	0.0000	0.0000	0.0374	0.0374	0.0690	0.0690	0.0690	0.0690	0.0690	0.0690
0.650	-0.0358	-0.0029	0.0313	0.0313	0.0576	0.0576	0.0576	0.0576	0.0576	0.0576
0.675	0.0000	-0.0143	0.0243	0.0243	0.0599	0.0599	0.0599	0.0599	0.0599	0.0599
0.700	-0.0302	-0.0209	0.0230	0.0230	0.0568	0.0568	0.0568	0.0568	0.0568	0.0568
0.725	0.0000	-0.0290	0.0000	0.0000	0.0568	0.0568	0.0568	0.0568	0.0568	0.0568
0.750	-0.0212	-0.0346	0.0000	0.0000	0.0555	0.0555	0.0555	0.0555	0.0555	0.0555
0.775	0.0000	-0.0375	0.0024	0.0024	0.0606	0.0606	0.0606	0.0606	0.0606	0.0606
0.800	-0.0023	-0.0400	0.0095	0.0095	0.0657	0.0657	0.0657	0.0657	0.0657	0.0657
0.825	0.0000	-0.0385	0.0206	0.0206	0.0616	0.0616	0.0616	0.0616	0.0616	0.0616
0.850	0.0214	-0.0336	0.0275	0.0275	0.0819	0.0819	0.0819	0.0819	0.0819	0.0819
0.875	0.0000	-0.0232	0.0334	0.0334	0.0902	0.0902	0.0902	0.0902	0.0902	0.0902
0.900	0.0551	-0.0110	0.0306	0.0306	0.0969	0.0969	0.0969	0.0969	0.0969	0.0969
0.925	0.0000	0.0135	0.0156	0.0156	0.0897	0.0897	0.0897	0.0897	0.0897	0.0897
0.950	0.1057	0.0496	0.0153	0.0153	0.0598	0.0598	0.0598	0.0598	0.0598	0.0598
0.975	0.0000	0.1055	0.0730	0.0730	0.0011	0.0011	0.0011	0.0011	0.0011	0.0011
1.000	0.2193	0.2123	0.1886	0.1886	0.1532	0.1532	0.1532	0.1532	0.1532	0.1532
-0.200	-0.0269	-0.0042	0.0814	0.0814	0.0000	0.0000	0.0000	0.0000	0.0000	0.0000
-0.400	-0.0521	-0.0047	0.0399	0.0399	-0.1025	-0.1025	-0.1025	-0.1025	-0.1025	-0.1025
-0.600	-0.0758	-0.0289	0.0119	0.0119	-0.0848	-0.0848	-0.0848	-0.0848	-0.0848	-0.0848
-0.700	-0.0784	-0.0648	-0.0143	-0.0143	-0.0836	-0.0836	-0.0836	-0.0836	-0.0836	-0.0836
-0.800	-0.0649	0.0000	-0.0596	-0.0596	-0.0984	-0.0984	-0.0984	-0.0984	-0.0984	-0.0984
-0.850	0.0000	-0.0986	-0.0924	-0.0924	-0.1292	-0.1292	-0.1292	-0.1292	-0.1292	-0.1292
-0.900	0.0000	-0.0875	-0.1096	-0.1096	-0.1660	-0.1660	-0.1660	-0.1660	-0.1660	-0.1660
-0.950	0.0347	-0.0402	-0.0808	-0.0808	-0.1577	-0.1577	-0.1577	-0.1577	-0.1577	-0.1577
-0.975	0.0000	0.0116	-0.0322	-0.0322	-0.1052	-0.1052	-0.1052	-0.1052	-0.1052	-0.1052
-1.000	0.1920	0.1816	0.1444	0.1444	0.1342	0.1342	0.1342	0.1342	0.1342	0.1342

Medium Radius L.E.
 Run No. = 19, Point No. = 369
 $C_N = -0.032$, $C_m = 0.0062$
 $\alpha = -0.7^\circ$, $M_\infty = 0.849$
 $R_{mac} = 72.5 \times 10^6$

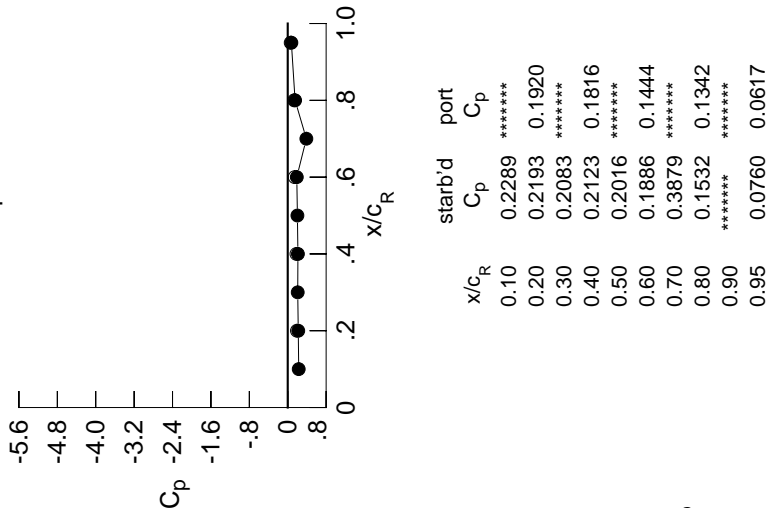
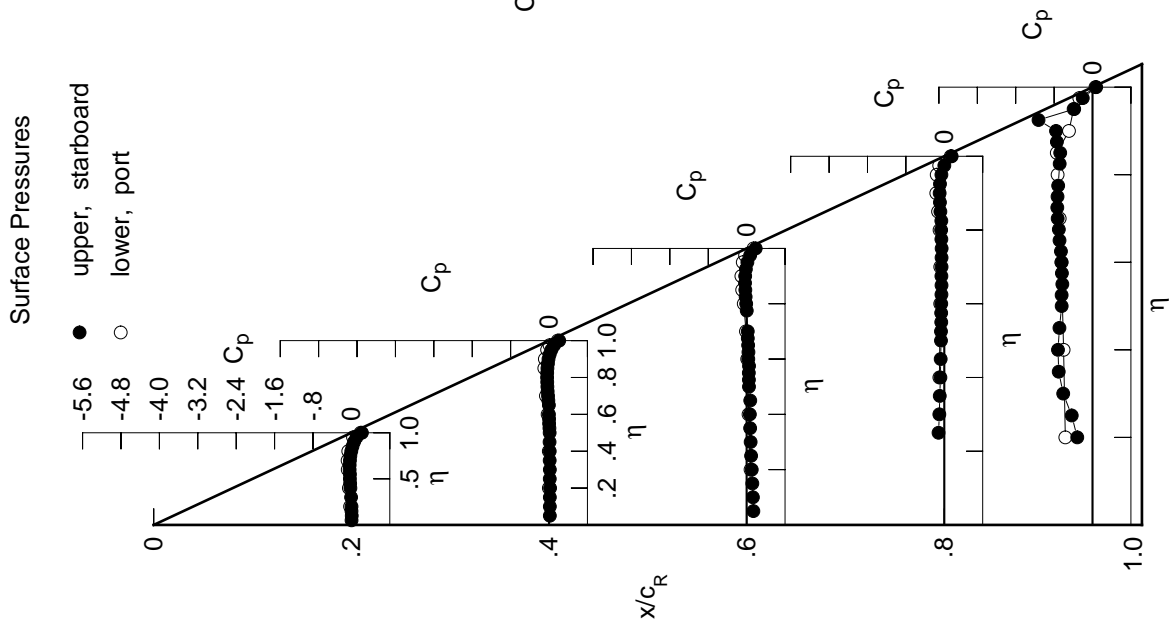

Table E7. Continued.

η	$x/c_R = .2$		$x/c_R = .4$		$x/c_R = .6$		$x/c_R = .8$		$x/c_R = .95$	
	$C_{p,u}$	$C_{p,u}$	$C_{p,u}$	$C_{p,u}$	$C_{p,u}$	$C_{p,u}$	$C_{p,u}$	$C_{p,u}$	$C_{p,u}$	$C_{p,u}$
0.050	-0.0025	0.0105	0.1361	*****	*****	*****	*****	*****	*****	
0.100	0.0005	0.0111	0.1262	*****	*****	*****	*****	*****	*****	
0.150	-0.0041	0.0109	0.1138	*****	*****	*****	*****	*****	*****	
0.200	-0.0045	0.0161	0.1021	*****	*****	*****	*****	*****	-0.3147	
0.250	*****	0.0104	0.0886	-0.1232	-0.4239	*****	*****	*****	*****	
0.300	-0.0141	0.0108	0.0791	-0.1072	-0.5925	*****	*****	*****	*****	
0.350	*****	0.0075	0.0683	-0.0982	-0.6921	*****	*****	*****	*****	
0.400	-0.0284	0.0081	0.0622	-0.0845	-0.7079	*****	*****	*****	*****	
0.450	-0.0335	0.0047	0.0707	-0.0792	-0.6749	*****	*****	*****	*****	
0.500	-0.0398	0.0059	0.0436	-0.0734	-0.6194	*****	*****	*****	*****	
0.525	*****	0.0007	0.0421	-0.0727	-0.6203	*****	*****	*****	*****	
0.550	-0.0400	-0.0059	0.0404	-0.0684	-0.6043	*****	*****	*****	*****	
0.575	*****	-0.0070	0.0440	-0.0698	-0.6119	*****	*****	*****	*****	
0.600	-0.0473	-0.0104	0.0284	-0.0692	-0.6166	*****	*****	*****	*****	
0.625	*****	*****	0.0310	-0.0642	-0.6340	*****	*****	*****	*****	
0.650	-0.0465	-0.0118	0.0255	-0.0626	-0.6689	*****	*****	*****	*****	
0.675	*****	-0.0232	0.0171	-0.0660	-0.6885	*****	*****	*****	*****	
0.700	-0.0421	-0.0314	0.0155	-0.0633	-0.7183	*****	*****	*****	*****	
0.725	*****	-0.0386	*****	-0.0627	-0.7333	*****	*****	*****	*****	
0.750	-0.0338	-0.0453	*****	-0.0623	-0.7310	*****	*****	*****	*****	
0.775	*****	-0.0498	-0.0067	-0.0681	-0.7124	*****	*****	*****	*****	
0.800	-0.0150	-0.0536	-0.0195	-0.0738	*****	*****	*****	*****	*****	
0.825	*****	-0.0529	-0.0331	-0.0706	-0.6695	*****	*****	*****	*****	
0.850	0.0076	-0.0492	-0.0409	-0.0920	-0.6645	*****	*****	*****	*****	
0.875	*****	-0.0388	-0.0479	-0.1027	-0.7522	*****	*****	*****	*****	
0.900	0.0409	-0.0284	-0.0470	-0.1118	-0.7537	*****	*****	*****	*****	
0.925	*****	-0.0047	-0.0341	-0.1074	-1.1107	*****	*****	*****	*****	
0.950	0.0909	-0.0309	-0.0051	-0.0794	-0.3932	*****	*****	*****	*****	
0.975	*****	0.0863	0.0529	-0.0206	-0.2205	*****	*****	*****	*****	
1.000	0.2247	0.2212	0.2065	0.1662	0.0858	*****	*****	*****	*****	
-0.200	$C_{p,l}$	$C_{p,l}$	$C_{p,l}$	$C_{p,l}$	$C_{p,l}$	$C_{p,l}$	$C_{p,l}$	$C_{p,l}$	$C_{p,l}$	
-0.400	-0.0200	0.0040	0.0852	*****	*****	-0.5739	*****	*****	*****	
-0.600	-0.0434	0.0022	0.0452	-0.0985	-0.6116	*****	*****	*****	*****	
-0.700	-0.0651	-0.0203	0.0188	-0.0784	-0.6507	*****	*****	*****	*****	
-0.800	-0.0662	-0.0542	-0.0061	-0.0776	-0.6859	*****	*****	*****	*****	
-0.850	-0.0503	*****	-0.0485	-0.0885	-0.7229	*****	*****	*****	*****	
-0.900	*****	-0.0818	-0.0777	-0.1171	-0.7510	*****	*****	*****	*****	
-0.950	*****	-0.0675	-0.0910	-0.1492	-0.5176	*****	*****	*****	*****	
-0.975	0.0532	-0.0172	-0.0566	-0.1346	-0.3809	*****	*****	*****	*****	
-1.000	0.1983	0.1929	0.1622	0.1543	0.0747	*****	*****	*****	*****	

Medium Radius L.E.
 Run No. = 19, Point No. = 370
 $C_N = -0.019$, $C_m = 0.0042$
 $\alpha = -0.3^\circ$, $M_\infty = 0.848$
 $R_{mac} = 72.5 \times 10^6$

Leading Edge Pressures

● starboard
 ○ port

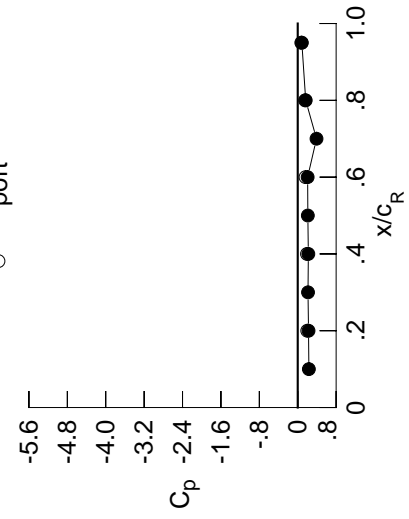

x/c_R	starb'd C_p	port C_p
0.10	0.2323	*****
0.20	0.2247	0.1983
0.30	0.2141	*****
0.40	0.2212	0.1929
0.50	0.2108	*****
0.60	0.2065	0.1622
0.70	0.3911	*****
0.80	0.1662	0.1543
0.90	*****	*****
0.95	0.0858	0.0747

Surface Pressures

● upper, starboard
 ○ lower, port

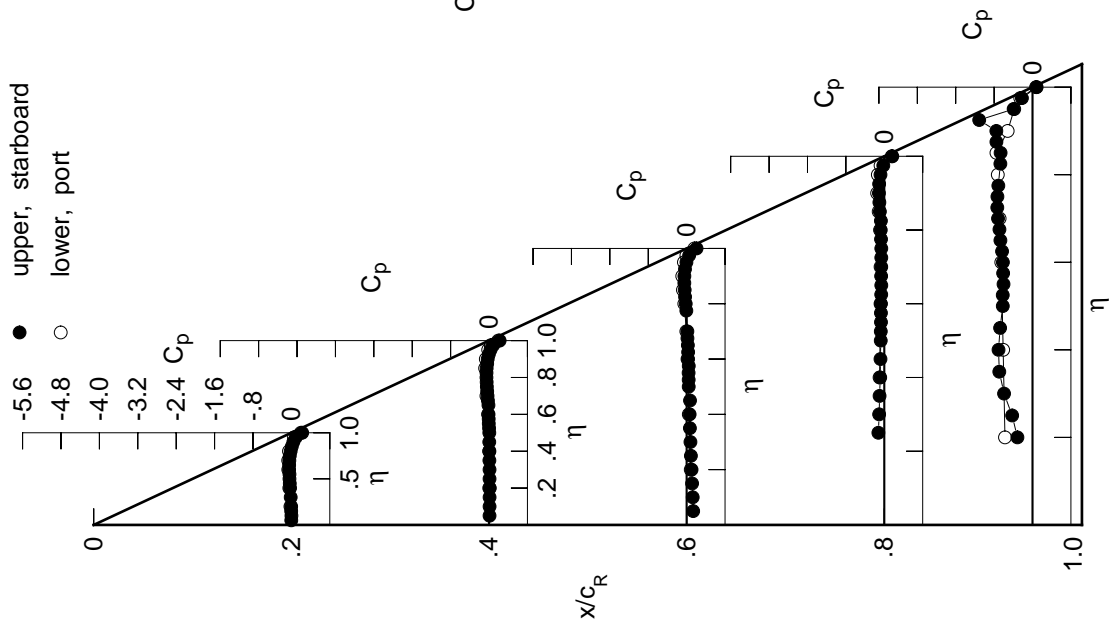

Table E7. Continued.

η	x/c_R .2	x/c_R .4	x/c_R .6	x/c_R .8	x/c_R .95
	$C_{p,u}$	$C_{p,u}$	$C_{p,u}$	$C_{p,u}$	$C_{p,u}$
0.050	-0.0226	-0.0059	0.1240	*****	*****
0.100	-0.0198	-0.0067	0.1142	*****	*****
0.150	-0.0226	-0.0060	0.1023	*****	*****
0.200	-0.0248	-0.0013	0.0894	*****	-0.2962
0.250	*****	-0.0076	0.0763	-0.1353	-0.4012
0.300	-0.0339	-0.0066	0.0655	-0.1194	-0.5640
0.350	*****	-0.0114	0.0550	-0.1100	-0.6812
0.400	-0.0516	-0.0102	0.0481	-0.0963	-0.7056
0.450	-0.0571	-0.0156	0.0560	-0.0918	-0.6729
0.500	-0.0650	-0.0140	0.0280	-0.0860	-0.6098
0.525	*****	-0.0207	0.0261	-0.0870	-0.6112
0.550	-0.0675	-0.0275	0.0235	-0.0823	-0.5945
0.575	*****	-0.0290	0.0273	-0.0851	-0.6044
0.600	-0.0766	-0.0340	0.0110	-0.0830	-0.6115
0.625	*****	*****	0.0124	-0.0799	-0.6353
0.650	-0.0781	-0.0367	0.0064	-0.0787	-0.6763
0.675	*****	-0.0498	-0.0037	-0.0827	-0.6996
0.700	-0.0763	-0.0596	-0.0061	-0.0809	-0.7278
0.725	*****	-0.0697	*****	-0.0831	-0.7332
0.750	-0.0697	-0.0786	*****	-0.0823	-0.6935
0.775	*****	-0.0862	-0.0345	-0.0917	-0.5766
0.800	-0.0541	-0.0920	-0.0506	-0.0986	*****
0.825	*****	-0.0955	-0.0673	-0.0967	-0.5316
0.850	-0.0338	-0.0938	-0.0815	-0.1251	-0.5870
0.875	*****	-0.0881	-0.0933	-0.1405	-0.7707
0.900	-0.0040	-0.0801	-0.0994	-0.1580	-0.7111
0.925	*****	-0.0624	-0.0913	-0.1609	-1.0627
0.950	-0.0438	-0.0293	-0.0704	-0.1436	-0.4307
0.975	*****	0.0210	-0.0182	-0.0937	-0.2768
1.000	0.2193	0.2126	0.2003	0.1533	0.0775
	$C_{p,l}$	$C_{p,l}$	$C_{p,l}$	$C_{p,l}$	$C_{p,l}$
-0.200	0.0003	0.0217	0.0989	*****	-0.6080
-0.400	-0.0207	0.0207	0.0606	-0.0851	-0.6590
-0.600	-0.0361	0.0036	0.0374	-0.0640	-0.7073
-0.700	-0.0318	-0.0244	0.0170	-0.0585	-0.7266
-0.800	-0.0108	*****	-0.0166	-0.0647	-0.7092
-0.850	*****	-0.0364	-0.0379	-0.0842	-0.7363
-0.900	*****	-0.0152	-0.0396	-0.1027	-0.6260
-0.950	0.1002	0.0414	0.0066	-0.0703	-0.3450
-0.975	*****	0.0999	0.0651	-0.0059	-0.2018
-1.000	0.1993	0.1943	0.1643	0.1615	0.0803

Medium Radius L.E.
 Run No. = 19, Point No. = 371
 $C_N = 0.023$, $C_m = -0.0029$
 $\alpha = 0.7^\circ$, $M_\infty = 0.848$
 $R_{mac} = 72.7 \times 10^6$

Leading Edge Pressures

● starboard
 ○ port

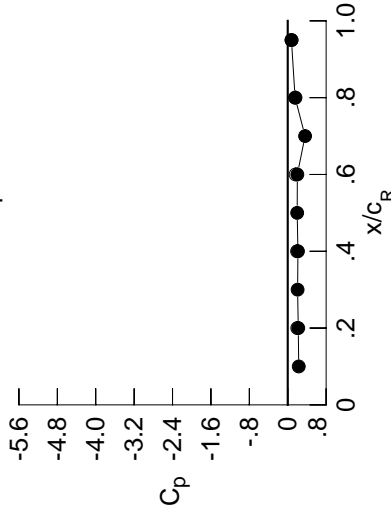

x/c_R	starb'd C_p	port C_p
0.10	0.2294	*****
0.20	0.2193	0.1993
0.30	0.2058	*****
0.40	0.2126	0.1943
0.50	0.1969	*****
0.60	0.2003	0.1643
0.70	0.3614	*****
0.80	0.1533	0.1615
0.90	*****	*****
0.95	0.0775	0.0803

Surface Pressures

● upper, starboard
 ○ lower, port

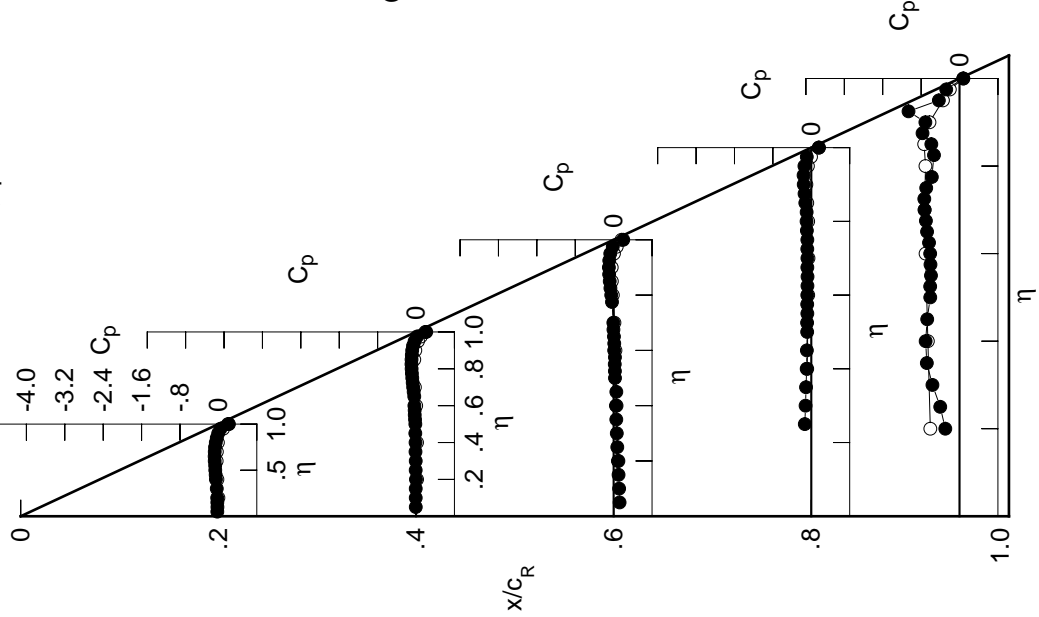

Table E7. Continued.

η	$x/c_R = .2$		$x/c_R = .4$		$x/c_R = .6$		$x/c_R = .8$		$x/c_R = .95$	
	$C_{p,u}$	$C_{p,u}$	$C_{p,u}$	$C_{p,u}$	$C_{p,u}$	$C_{p,u}$	$C_{p,u}$	$C_{p,u}$	$C_{p,u}$	$C_{p,u}$
0.050	-0.0434	-0.0235	0.1099	*****	*****	*****	*****	*****	*****	*****
0.100	-0.0403	-0.0253	0.1013	*****	*****	*****	*****	*****	*****	*****
0.150	-0.0434	-0.0236	0.0883	*****	*****	*****	*****	*****	*****	*****
0.200	-0.0459	-0.0212	0.0758	*****	*****	*****	*****	*****	*****	-0.2709
0.250	*****	-0.0259	0.0615	-0.1476	-0.1476	-0.1476	-0.1476	-0.1476	-0.1476	-0.3650
0.300	-0.0550	-0.0266	0.0510	-0.1325	-0.1325	-0.1325	-0.1325	-0.1325	-0.1325	-0.5023
0.350	*****	-0.0312	0.0395	-0.1222	-0.1222	-0.1222	-0.1222	-0.1222	-0.1222	-0.6478
0.400	-0.0749	-0.0304	0.0315	-0.1108	-0.1108	-0.1108	-0.1108	-0.1108	-0.1108	-0.7161
0.450	-0.0828	-0.0362	0.0392	-0.1048	-0.1048	-0.1048	-0.1048	-0.1048	-0.1048	-0.7020
0.500	-0.0916	-0.0362	0.0101	-0.1006	-0.1006	-0.1006	-0.1006	-0.1006	-0.1006	-0.6514
0.525	*****	-0.0439	0.0086	-0.1011	-0.1011	-0.1011	-0.1011	-0.1011	-0.1011	-0.6502
0.550	-0.0965	-0.0509	0.0047	-0.0979	-0.0979	-0.0979	-0.0979	-0.0979	-0.0979	-0.6394
0.575	*****	-0.0546	0.0082	-0.1004	-0.1004	-0.1004	-0.1004	-0.1004	-0.1004	-0.6542
0.600	-0.1075	-0.0592	-0.0097	-0.0996	-0.0996	-0.0996	-0.0996	-0.0996	-0.0996	-0.6693
0.625	*****	*****	-0.0084	-0.0973	-0.0973	-0.0973	-0.0973	-0.0973	-0.0973	-0.6940
0.650	-0.1123	-0.0642	-0.0152	-0.0974	-0.0974	-0.0974	-0.0974	-0.0974	-0.0974	-0.7221
0.675	*****	-0.0783	-0.0267	-0.1009	-0.1009	-0.1009	-0.1009	-0.1009	-0.1009	-0.7223
0.700	-0.1131	-0.0913	-0.0297	-0.1015	-0.1015	-0.1015	-0.1015	-0.1015	-0.1015	-0.7112
0.725	*****	-0.1030	*****	-0.1033	-0.1033	-0.1033	-0.1033	-0.1033	-0.1033	-0.6416
0.750	-0.1100	-0.1148	*****	-0.1080	-0.1080	-0.1080	-0.1080	-0.1080	-0.1080	-0.4893
0.775	*****	-0.1251	-0.0651	-0.1165	-0.1165	-0.1165	-0.1165	-0.1165	-0.1165	-0.3434
0.800	-0.0974	-0.1356	-0.0845	-0.1269	-0.1269	-0.1269	-0.1269	-0.1269	-0.1269	*****
0.825	*****	-0.1425	-0.1075	-0.1266	-0.1266	-0.1266	-0.1266	-0.1266	-0.1266	-0.3625
0.850	-0.0811	-0.1448	-0.1254	-0.1602	-0.1602	-0.1602	-0.1602	-0.1602	-0.1602	-0.4208
0.875	*****	-0.1452	-0.1451	-0.1839	-0.1839	-0.1839	-0.1839	-0.1839	-0.1839	-0.7076
0.900	-0.0555	-0.1405	-0.1574	-0.2106	-0.2106	-0.2106	-0.2106	-0.2106	-0.2106	-0.6947
0.925	*****	-0.1294	-0.1584	-0.2238	-0.2238	-0.2238	-0.2238	-0.2238	-0.2238	-1.1048
0.950	-0.0139	-0.1003	-0.1473	-0.2186	-0.2186	-0.2186	-0.2186	-0.2186	-0.2186	-0.4746
0.975	*****	-0.0622	-0.1080	-0.1837	-0.1837	-0.1837	-0.1837	-0.1837	-0.1837	-0.3435
1.000	0.1869	0.1555	0.1221	0.0662	0.0662	0.0662	0.0662	0.0662	0.0662	0.0152
$C_{p,l}$	$C_{p,l}$	$C_{p,l}$	$C_{p,l}$	$C_{p,l}$	$C_{p,l}$	$C_{p,l}$	$C_{p,l}$	$C_{p,l}$	$C_{p,l}$	$C_{p,l}$
-0.200	0.0203	0.0387	0.1109	*****	*****	*****	*****	*****	*****	-0.6223
-0.400	0.0022	0.0395	0.0753	-0.0728	-0.0728	-0.0728	-0.0728	-0.0728	-0.0728	-0.7065
-0.600	-0.0064	0.0266	0.0538	-0.0481	-0.0481	-0.0481	-0.0481	-0.0481	-0.0481	-0.7278
-0.700	0.0011	0.0039	0.0390	-0.0410	-0.0410	-0.0410	-0.0410	-0.0410	-0.0410	-0.7328
-0.800	0.0272	*****	0.0128	-0.0401	-0.0401	-0.0401	-0.0401	-0.0401	-0.0401	-0.6922
-0.850	*****	0.0068	0.0003	-0.0532	-0.0532	-0.0532	-0.0532	-0.0532	-0.0532	-0.7137
-0.900	*****	0.0327	0.0072	-0.0603	-0.0603	-0.0603	-0.0603	-0.0603	-0.0603	-0.7487
-0.950	0.1412	0.0922	0.0612	-0.0149	-0.0149	-0.0149	-0.0149	-0.0149	-0.0149	-0.3145
-0.975	*****	0.1500	0.1202	0.0515	0.0515	0.0515	0.0515	0.0515	0.0515	-0.1567
-1.000	0.1696	0.1478	0.0952	0.0928	0.0928	0.0928	0.0928	0.0928	0.0928	0.0332

Medium Radius L.E.
 Run No. = 19, Point No. = 372
 $C_N = 0.063$, $C_m = -0.0084$
 $\alpha = 1.8^\circ$, $M_\infty = 0.848$
 $R_{mac} = 72.8 \times 10^6$

Leading Edge Pressures

● starboard
 ○ port

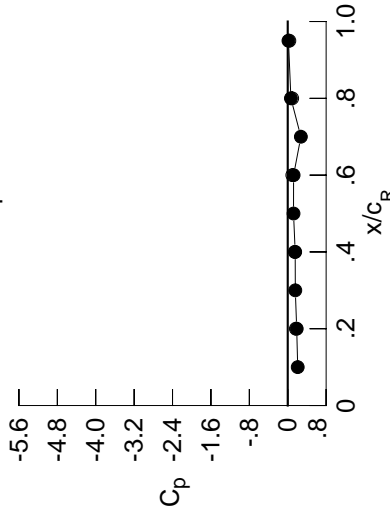

x/c_R	starb'd C_p	port C_p
0.10	0.2080	*****
0.20	0.1869	0.1696
0.30	0.1579	*****
0.40	0.1555	0.1478
0.50	0.1207	*****
0.60	0.1221	0.0952
0.70	0.2740	*****
0.80	0.0662	0.0928
0.90	*****	*****
0.95	0.0152	0.0332

Surface Pressures

● upper, starboard
 ○ lower, port

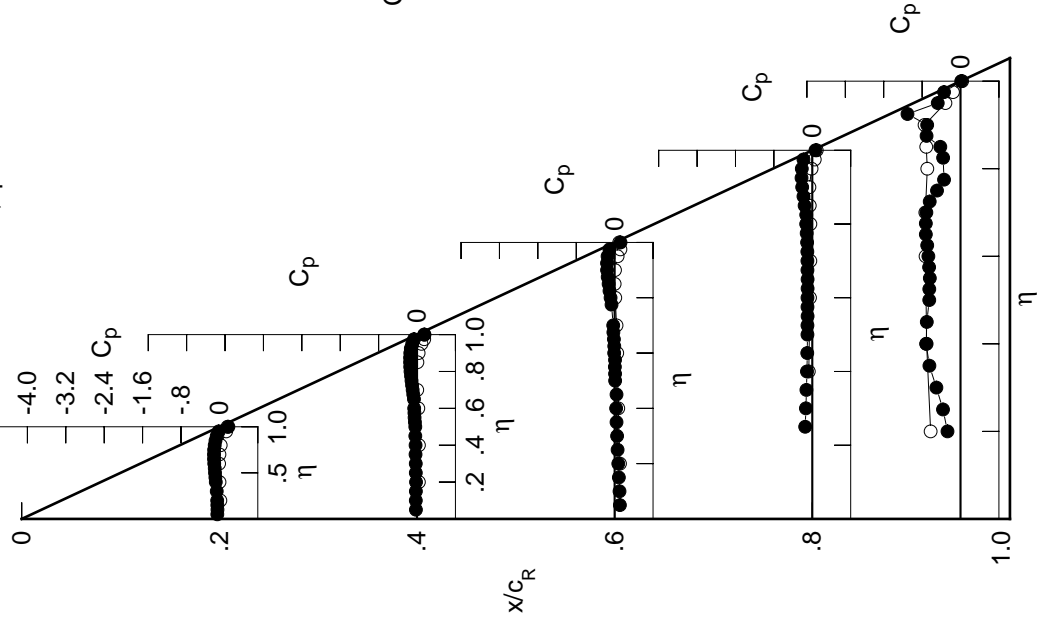

Table E7. Continued.

η	$x/c_R = .2$		$x/c_R = .4$		$x/c_R = .6$		$x/c_R = .8$		$x/c_R = .95$	
	$C_{p,u}$	$C_{p,u}$	$C_{p,u}$	$C_{p,u}$	$C_{p,u}$	$C_{p,u}$	$C_{p,u}$	$C_{p,u}$	$C_{p,u}$	$C_{p,u}$
0.050	-0.0623	-0.0417	0.0989	*****	*****	*****	*****	*****	*****	*****
0.100	-0.0595	-0.0421	0.0896	*****	*****	*****	*****	*****	*****	*****
0.150	-0.0627	-0.0422	0.0762	*****	*****	*****	*****	*****	*****	*****
0.200	-0.0646	-0.0382	0.0634	*****	*****	*****	*****	*****	*****	-0.2619
0.250	*****	-0.0442	0.0493	-0.1597	-0.3514	*****	*****	*****	*****	*****
0.300	-0.0753	-0.0446	0.0380	-0.1445	-0.4758	*****	*****	*****	*****	*****
0.350	*****	-0.0495	0.0258	-0.1348	-0.6261	*****	*****	*****	*****	*****
0.400	-0.0971	-0.0503	0.0176	-0.1226	-0.7148	*****	*****	*****	*****	*****
0.450	-0.1070	-0.0565	0.0238	-0.1189	-0.7129	*****	*****	*****	*****	*****
0.500	-0.1178	-0.0580	-0.0056	-0.1143	-0.6693	*****	*****	*****	*****	*****
0.525	*****	-0.0651	-0.0083	-0.1153	-0.6694	*****	*****	*****	*****	*****
0.550	-0.1249	-0.0743	-0.0129	-0.1125	-0.6608	*****	*****	*****	*****	*****
0.575	*****	-0.0781	-0.0101	-0.1156	-0.6781	*****	*****	*****	*****	*****
0.600	-0.1387	-0.0847	-0.0284	-0.1162	-0.6977	*****	*****	*****	*****	*****
0.625	*****	*****	-0.0276	-0.1138	-0.7192	*****	*****	*****	*****	*****
0.650	-0.1460	-0.0906	-0.0360	-0.1150	-0.7331	*****	*****	*****	*****	*****
0.675	*****	-0.1076	-0.0479	-0.1195	-0.7040	*****	*****	*****	*****	*****
0.700	-0.1497	-0.1213	-0.0533	-0.1210	-0.6238	*****	*****	*****	*****	*****
0.725	*****	-0.1372	*****	-0.1250	-0.4932	*****	*****	*****	*****	*****
0.750	-0.1500	-0.1510	*****	-0.1299	-0.3655	*****	*****	*****	*****	*****
0.775	*****	-0.1656	-0.0953	-0.1418	-0.2546	*****	*****	*****	*****	*****
0.800	-0.1414	-0.1794	-0.1191	-0.1560	*****	*****	*****	*****	*****	*****
0.825	*****	-0.1907	-0.1460	-0.1563	-0.2860	*****	*****	*****	*****	*****
0.850	-0.1293	-0.1984	-0.1721	-0.1973	-0.3159	*****	*****	*****	*****	*****
0.875	*****	-0.2031	-0.1984	-0.2281	-0.5191	*****	*****	*****	*****	*****
0.900	-0.1097	-0.2050	-0.2202	-0.2652	-0.6580	*****	*****	*****	*****	*****
0.925	*****	-0.2003	-0.2319	-0.2902	-1.0125	*****	*****	*****	*****	*****
0.950	-0.0758	-0.1801	-0.2328	-0.3006	-0.5213	*****	*****	*****	*****	*****
0.975	*****	-0.1565	-0.2121	-0.2878	-0.4214	*****	*****	*****	*****	*****
1.000	0.1270	0.0494	-0.0006	-0.0897	-0.1029	*****	*****	*****	*****	*****
	$C_{p,l}$	$C_{p,l}$	$C_{p,l}$	$C_{p,l}$	$C_{p,l}$	$C_{p,l}$	$C_{p,l}$	$C_{p,l}$	$C_{p,l}$	$C_{p,l}$
-0.200	0.0422	0.0568	0.1252	*****	-0.6453	*****	*****	*****	*****	*****
-0.400	0.0258	0.0596	0.0898	-0.0588	-0.7297	*****	*****	*****	*****	*****
-0.600	0.0222	0.0496	0.0727	-0.0329	-0.7430	*****	*****	*****	*****	*****
-0.700	0.0333	0.0314	0.0609	-0.0232	-0.7278	*****	*****	*****	*****	*****
-0.800	0.0623	*****	0.0416	-0.0177	-0.6766	*****	*****	*****	*****	*****
-0.850	*****	0.0453	0.0354	-0.0246	-0.6919	*****	*****	*****	*****	*****
-0.900	*****	0.0759	0.0494	-0.0212	-0.7272	*****	*****	*****	*****	*****
-0.950	0.1739	0.1339	0.1069	0.0323	-0.2883	*****	*****	*****	*****	*****
-0.975	*****	0.1852	0.1611	0.0954	-0.1205	*****	*****	*****	*****	*****
-1.000	0.1112	0.0498	-0.0528	-0.0456	-0.0620	*****	*****	*****	*****	*****

Medium Radius L.E.
 Run No. = 19, Point No. = 373
 $C_N = 0.106$, $C_m = -0.0152$
 $\alpha = 2.9^\circ$, $M_\infty = 0.849$
 $R_{mac} = 72.5 \times 10^6$

Leading Edge Pressures

● starboard
 ○ port

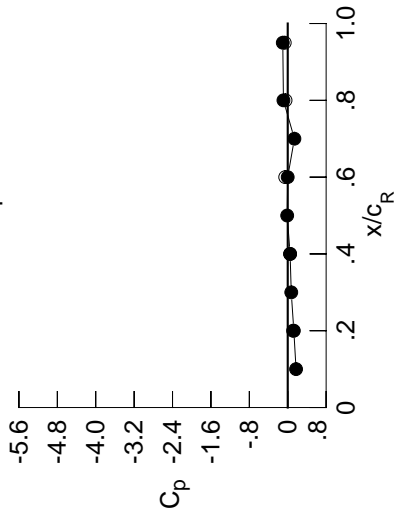

x/c_R	starb'd C_p	port C_p
0.10	0.1735	*****
0.20	0.1270	0.1112
0.30	0.0733	*****
0.40	0.0494	0.0498
0.50	-0.0115	*****
0.60	-0.0006	-0.0528
0.70	0.1391	*****
0.80	-0.0897	-0.0456
0.90	*****	*****
0.95	-0.1029	-0.0620

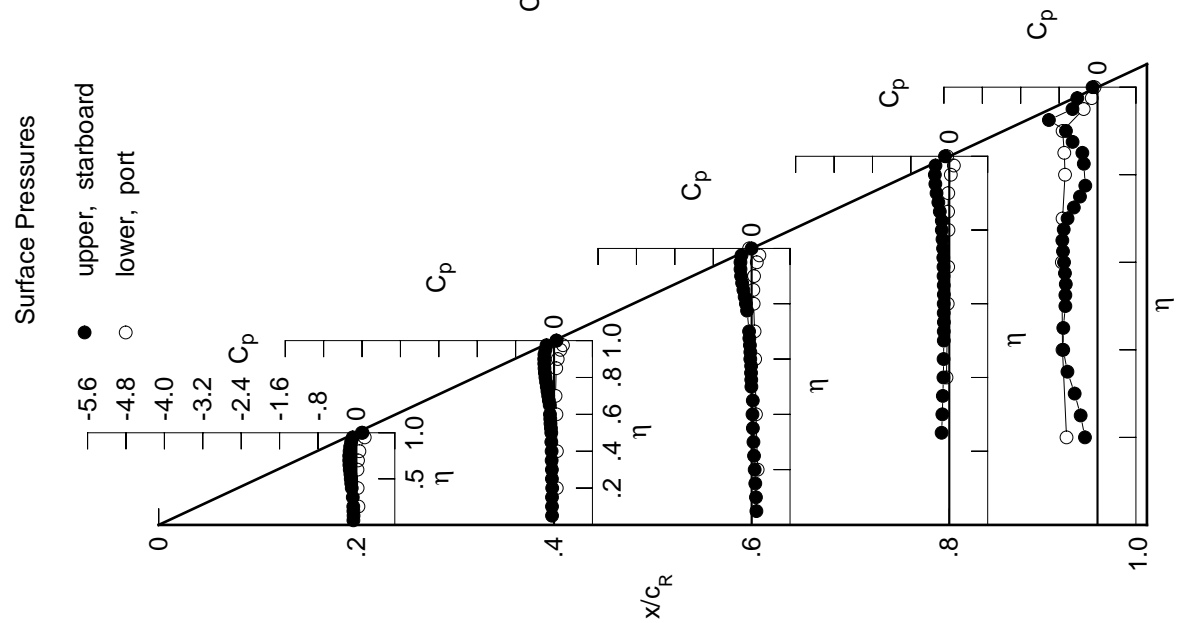

Table E7. Continued.

η	x/c_R .2		x/c_R .4		x/c_R .6		x/c_R .8		x/c_R .95	
	$C_{p,u}$	$C_{p,u}$	$C_{p,u}$	$C_{p,u}$	$C_{p,u}$	$C_{p,u}$	$C_{p,u}$	$C_{p,u}$	$C_{p,u}$	$C_{p,u}$
0.050	-0.0809	-0.0582	0.0870	0.0870	0.0870	0.0870	0.0870	0.0870	0.0870	0.0870
0.100	-0.0781	-0.0588	0.0783	0.0783	0.0783	0.0783	0.0783	0.0783	0.0783	0.0783
0.150	-0.0821	-0.0591	0.0649	0.0649	0.0649	0.0649	0.0649	0.0649	0.0649	0.0649
0.200	-0.0835	-0.0554	0.0519	0.0519	0.0519	0.0519	0.0519	0.0519	0.0519	0.0519
0.250	*****	-0.0617	0.0369	0.0369	0.0369	0.0369	0.0369	0.0369	0.0369	-0.2710
0.300	-0.0952	-0.0626	0.0254	0.0254	-0.1555	-0.1555	-0.4492	-0.4492	-0.4492	-0.3457
0.350	*****	-0.0685	0.0128	0.0128	-0.1464	-0.1464	-0.5749	-0.5749	-0.5749	-0.4492
0.400	-0.1196	-0.0697	0.0024	0.0024	-0.1350	-0.1350	-0.6692	-0.6692	-0.6692	-0.5749
0.450	-0.1313	-0.0770	0.0091	0.0091	-0.1309	-0.1309	-0.6784	-0.6784	-0.6784	-0.6692
0.500	-0.1442	-0.0788	-0.0205	-0.0205	-0.1278	-0.1278	-0.6400	-0.6400	-0.6400	-0.6784
0.525	*****	-0.0881	-0.0249	-0.0249	-0.1294	-0.1294	-0.6457	-0.6457	-0.6457	-0.6400
0.550	-0.1536	-0.0972	-0.0296	-0.0296	-0.1268	-0.1268	-0.6390	-0.6390	-0.6390	-0.6457
0.575	*****	-0.1021	-0.0284	-0.0284	-0.1302	-0.1302	-0.6584	-0.6584	-0.6584	-0.6390
0.600	-0.1697	-0.1097	-0.0475	-0.0475	-0.1316	-0.1316	-0.6759	-0.6759	-0.6759	-0.6584
0.625	*****	*****	-0.0473	-0.0473	-0.1297	-0.1297	-0.6903	-0.6903	-0.6903	-0.6759
0.650	-0.1811	-0.1183	-0.0574	-0.0574	-0.1318	-0.1318	-0.6890	-0.6890	-0.6890	-0.6903
0.675	*****	-0.1374	-0.0697	-0.0697	-0.1390	-0.1390	-0.6188	-0.6188	-0.6188	-0.6890
0.700	-0.1882	-0.1536	-0.0776	-0.0776	-0.1413	-0.1413	-0.5097	-0.5097	-0.5097	-0.6188
0.725	*****	-0.1716	*****	-0.1466	-0.1466	-0.4063	-0.4063	-0.4063	-0.4063	-0.5097
0.750	-0.1924	-0.1896	*****	-0.1528	-0.1528	-0.3089	-0.3089	-0.3089	-0.3089	-0.4063
0.775	*****	-0.2082	-0.1264	-0.1264	-0.1670	-0.1670	-0.2151	-0.2151	-0.2151	-0.3089
0.800	-0.1888	-0.2257	-0.1552	-0.1552	-0.1848	-0.1848	*****	*****	*****	-0.2151
0.825	*****	-0.2430	-0.1881	-0.1881	-0.1886	-0.1886	-0.2538	-0.2538	-0.2538	-0.1848
0.850	-0.1828	-0.2560	-0.2206	-0.2206	-0.2340	-0.2340	-0.2746	-0.2746	-0.2746	-0.2538
0.875	*****	-0.2667	-0.2552	-0.2552	-0.2748	-0.2748	-0.4175	-0.4175	-0.4175	-0.2746
0.900	-0.1699	-0.2766	-0.2882	-0.2882	-0.3225	-0.3225	-0.6340	-0.6340	-0.6340	-0.4175
0.925	*****	-0.2807	-0.3117	-0.3117	-0.3624	-0.3624	-0.8822	-0.8822	-0.8822	-0.6340
0.950	-0.1477	-0.2709	-0.3293	-0.3293	-0.3913	-0.3913	-0.5753	-0.5753	-0.5753	-0.8822
0.975	*****	-0.2678	-0.3320	-0.3320	-0.4071	-0.4071	-0.5131	-0.5131	-0.5131	-0.5753
1.000	0.0356	-0.1154	-0.1717	-0.1717	-0.3166	-0.3166	-0.2761	-0.2761	-0.2761	-0.5131
-0.200	$C_{p,l}$	0.0756	0.1392	0.1392	0.1392	0.1392	0.1392	0.1392	0.1392	0.1392
-0.400	$C_{p,l}$	0.0496	0.0793	0.1065	0.1065	0.0458	0.0458	0.0458	0.0458	0.0458
-0.600	$C_{p,l}$	0.0510	0.0729	0.0910	0.0910	0.0174	0.0174	0.0174	0.0174	0.0174
-0.700	$C_{p,l}$	0.0654	0.0594	0.0822	0.0822	-0.0056	-0.0056	-0.7155	-0.7155	-0.7155
-0.800	$C_{p,l}$	0.0965	*****	0.0690	0.0690	0.0056	0.0056	-0.6600	-0.6600	-0.6600
-0.850	$C_{p,l}$	*****	0.0824	0.0679	0.0679	0.0032	0.0032	-0.6705	-0.6705	-0.6705
-0.900	$C_{p,l}$	*****	0.1147	0.0873	0.0873	0.0143	0.0143	-0.6891	-0.6891	-0.6891
-0.950	$C_{p,l}$	0.2020	0.1682	0.1444	0.1444	0.0714	0.0714	-0.2649	-0.2649	-0.2649
-0.975	$C_{p,l}$	*****	0.2084	0.1892	0.1892	0.1284	0.1284	-0.0923	-0.0923	-0.0923
-1.000	$C_{p,l}$	0.0198	-0.0945	-0.2692	-0.2692	-0.2565	-0.2565	-0.2048	-0.2048	-0.2048

Medium Radius L.E.
 Run No. = 19, Point No. = 374
 $C_N = 0.148$, $C_m = -0.0231$
 $\alpha = 3.9^\circ$, $M_\infty = 0.849$
 $R_{mac} = 72.3 \times 10^6$

Leading Edge Pressures

● starboard
 ○ port

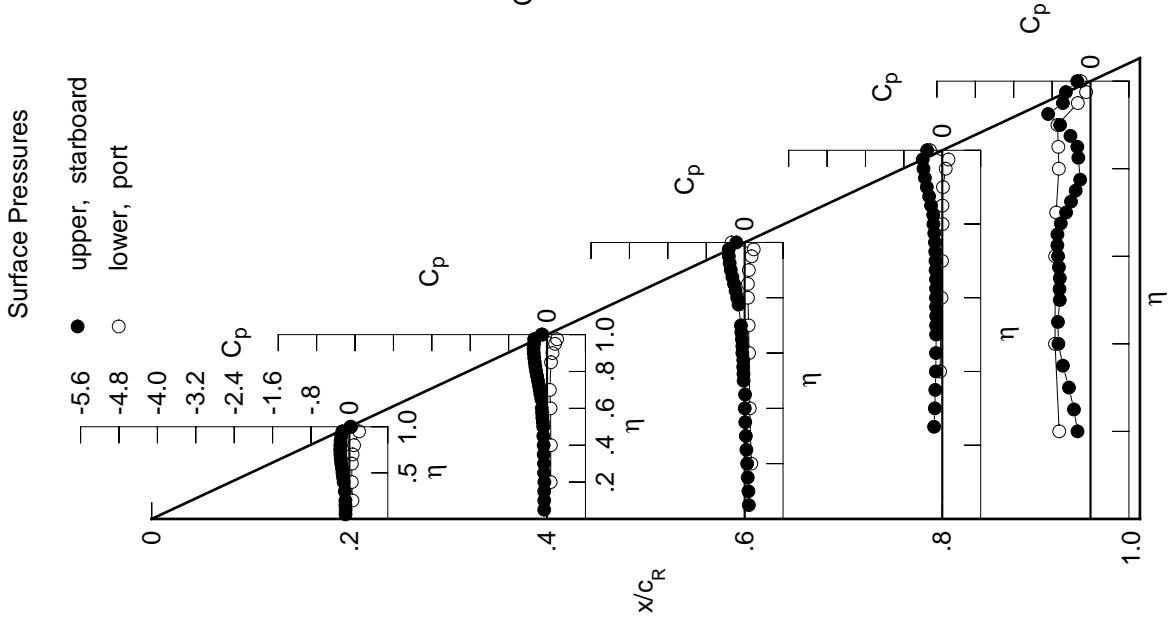
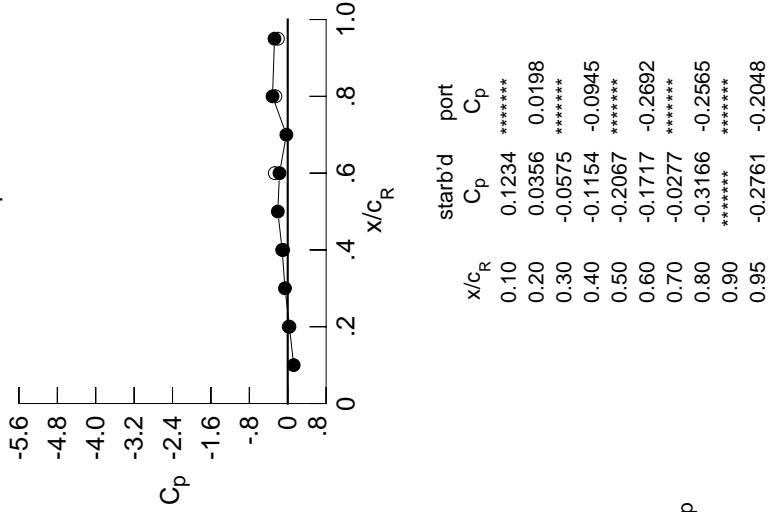

Table E7. Continued.

η	$x/c_R = .2$		$x/c_R = .4$		$x/c_R = .6$		$x/c_R = .8$		$x/c_R = .95$	
	$C_{p,u}$	$C_{p,u}$	$C_{p,u}$	$C_{p,u}$	$C_{p,u}$	$C_{p,u}$	$C_{p,u}$	$C_{p,u}$	$C_{p,u}$	$C_{p,u}$
0.050	-0.0986	-0.0745	0.0763	*****	*****	*****	*****	*****	*****	*****
0.100	-0.0962	-0.0743	0.0665	*****	*****	*****	*****	*****	*****	*****
0.150	-0.1003	-0.0757	0.0534	*****	*****	*****	*****	*****	*****	*****
0.200	-0.1026	-0.0711	0.0402	*****	*****	*****	*****	*****	*****	-0.2816
0.250	*****	-0.0784	0.0241	-0.1830	-0.1667	-0.1585	-0.1523	*****	*****	*****
0.300	-0.1152	-0.0797	0.0134	-0.1667	-0.1585	-0.1523	*****	*****	*****	*****
0.350	*****	-0.0865	-0.0007	-0.1585	-0.1523	*****	*****	*****	*****	*****
0.400	-0.1421	-0.0881	-0.0105	-0.1472	-0.1429	-0.1386	-0.1344	*****	*****	*****
0.450	-0.1552	-0.0965	-0.0056	-0.1438	-0.1417	-0.1404	-0.1391	*****	*****	*****
0.500	-0.1698	-0.0999	-0.0371	-0.1417	-0.1417	-0.1417	-0.1417	*****	*****	*****
0.525	*****	-0.1101	-0.0419	-0.1429	-0.1429	-0.1429	-0.1429	*****	*****	*****
0.550	-0.1818	-0.1204	-0.0470	-0.1419	-0.1419	-0.1419	-0.1419	*****	*****	*****
0.575	*****	-0.1261	-0.0466	-0.1456	-0.1456	-0.1456	-0.1456	*****	*****	*****
0.600	-0.2011	-0.1349	-0.0664	-0.1478	-0.1478	-0.1478	-0.1478	*****	*****	*****
0.625	*****	*****	-0.0672	-0.1464	-0.1464	-0.1464	-0.1464	*****	*****	*****
0.650	-0.2153	-0.1456	-0.0782	-0.1501	-0.1501	-0.1501	-0.1501	*****	*****	*****
0.675	*****	-0.1669	-0.0921	-0.1575	-0.1575	-0.1575	-0.1575	*****	*****	*****
0.700	-0.2268	-0.1852	-0.1017	-0.1612	-0.1612	-0.1612	-0.1612	*****	*****	*****
0.725	*****	-0.2065	*****	-0.1680	-0.1680	-0.1680	-0.1680	*****	*****	*****
0.750	-0.2357	-0.2274	*****	-0.1767	-0.1767	-0.1767	-0.1767	*****	*****	*****
0.775	*****	-0.2498	-0.1590	-0.1941	-0.1941	-0.1941	-0.1941	*****	*****	*****
0.800	-0.2368	-0.2734	-0.1916	-0.2143	-0.2143	-0.2143	-0.2143	*****	*****	*****
0.825	*****	-0.2951	-0.2297	-0.2199	-0.2199	-0.2199	-0.2199	*****	*****	*****
0.850	-0.2367	-0.3136	-0.2687	-0.2725	-0.2725	-0.2725	-0.2725	*****	*****	*****
0.875	*****	-0.3320	-0.3140	-0.3207	-0.3207	-0.3207	-0.3207	*****	*****	*****
0.900	-0.2319	-0.3493	-0.3580	-0.3822	-0.3822	-0.3822	-0.3822	*****	*****	*****
0.925	*****	-0.3648	-0.3973	-0.4388	-0.4388	-0.4388	-0.4388	*****	*****	*****
0.950	-0.2229	-0.3690	-0.4313	-0.4898	-0.4898	-0.4898	-0.4898	*****	*****	*****
0.975	*****	-0.3900	-0.4650	-0.5416	-0.5416	-0.5416	-0.5416	*****	*****	*****
1.000	-0.0820	-0.3078	-0.3705	-0.6174	-0.6174	-0.6174	-0.6174	*****	*****	*****
	$C_{p,l}$	$C_{p,l}$	$C_{p,l}$	$C_{p,l}$	$C_{p,l}$	$C_{p,l}$	$C_{p,l}$	$C_{p,l}$	$C_{p,l}$	$C_{p,l}$
-0.200	0.0859	0.0941	0.1535	*****	*****	*****	*****	*****	*****	-0.6524
-0.400	0.0732	0.0991	0.1214	-0.0315	-0.7413	*****	*****	*****	*****	*****
-0.600	0.0787	0.0952	0.1090	-0.0018	-0.7274	*****	*****	*****	*****	*****
-0.700	0.0951	0.0850	0.1025	0.0118	-0.7039	*****	*****	*****	*****	*****
-0.800	0.1279	*****	0.0947	0.0257	-0.6449	*****	*****	*****	*****	*****
-0.850	*****	0.1151	0.0977	0.0280	-0.6511	*****	*****	*****	*****	*****
-0.900	*****	0.1473	0.1203	0.0447	-0.6575	*****	*****	*****	*****	*****
-0.950	0.2218	0.1939	0.1721	0.1028	-0.2452	*****	*****	*****	*****	*****
-0.975	*****	0.2190	0.2044	0.1486	-0.0732	*****	*****	*****	*****	*****
-1.000	-0.0938	-0.2695	-0.5451	-0.5402	-0.3991	*****	*****	*****	*****	*****

Medium Radius L.E.
 Run No. = 19, Point No. = 375
 $C_N = 0.191$, $C_m = -0.0307$
 $\alpha = 5.0^\circ$, $M_\infty = 0.849$
 $R_{mac} = 72.1 \times 10^6$

Leading Edge Pressures

● starboard
 ○ port

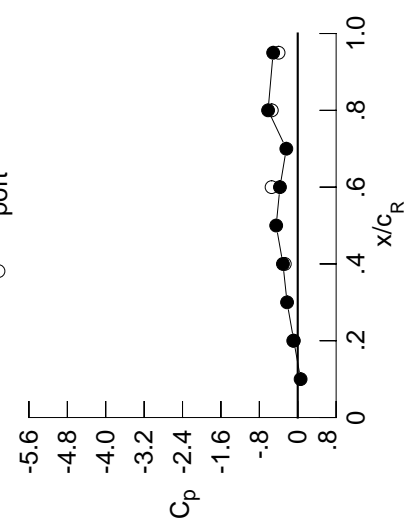

x/c_R	starb'd C_p	port C_p
0.10	0.0600	*****
0.20	-0.0820	-0.0938
0.30	-0.2224	*****
0.40	-0.3078	-0.2695
0.50	-0.4491	*****
0.60	-0.3705	-0.5451
0.70	-0.2379	*****
0.80	-0.6174	-0.5402
0.90	*****	*****
0.95	-0.5123	-0.3991

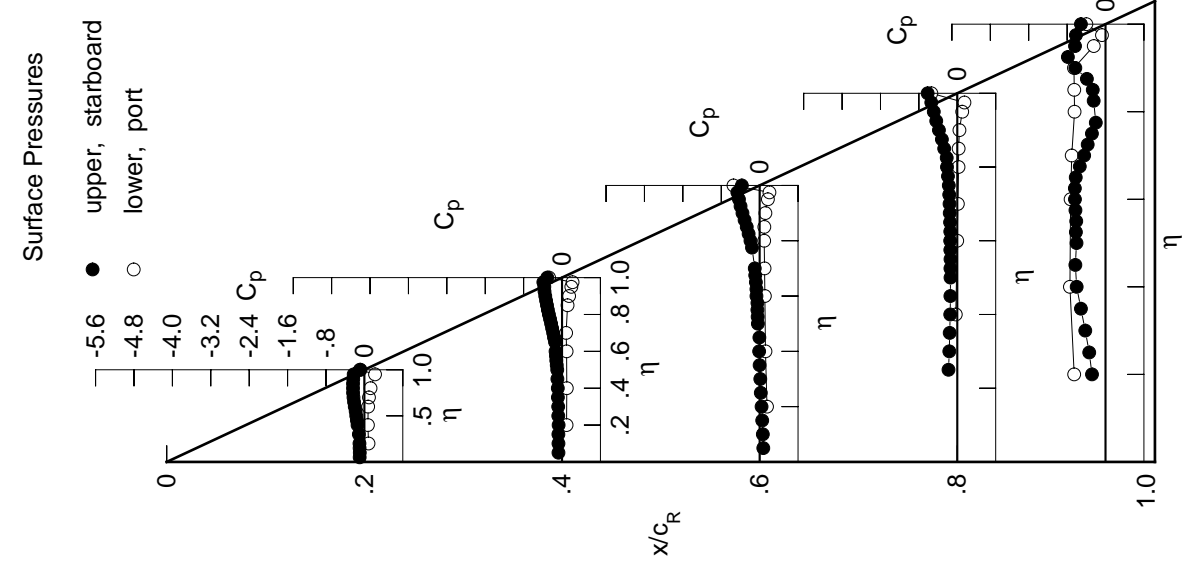
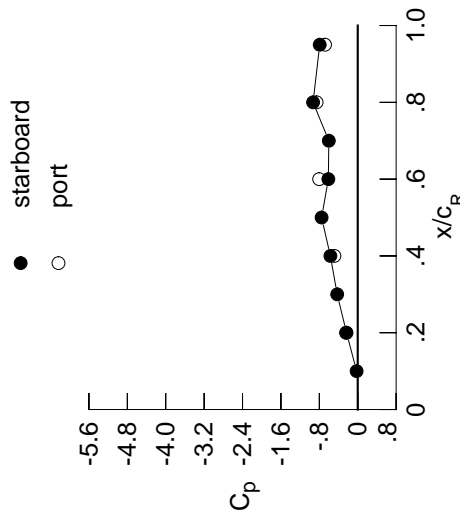

Table E7. Continued.

η	$x/c_R = .2$		$x/c_R = .4$		$x/c_R = .6$		$x/c_R = .8$		$x/c_R = .95$	
	$C_{p,u}$	$C_{p,u}$	$C_{p,u}$	$C_{p,u}$	$C_{p,u}$	$C_{p,u}$	$C_{p,u}$	$C_{p,u}$	$C_{p,u}$	$C_{p,u}$
0.050	-0.1174	-0.0919	0.0639	0.0639	0.0639	0.0639	0.0639	0.0639	0.0639	0.0639
0.100	-0.1166	-0.0914	0.0547	0.0547	0.0547	0.0547	0.0547	0.0547	0.0547	0.0547
0.150	-0.1205	-0.0940	0.0412	0.0412	0.0412	0.0412	0.0412	0.0412	0.0412	0.0412
0.200	-0.1233	-0.0897	0.0276	0.0276	0.0276	0.0276	0.0276	0.0276	0.0276	0.0276
0.250	*****	-0.0979	0.0111	-0.1958	-0.1958	-0.1958	-0.1958	-0.1958	-0.1958	-0.1958
0.300	-0.1364	-0.0994	-0.0004	-0.1803	-0.1803	-0.1803	-0.1803	-0.1803	-0.1803	-0.1803
0.350	*****	-0.1069	-0.0148	-0.1713	-0.1713	-0.1713	-0.1713	-0.1713	-0.1713	-0.1713
0.400	-0.1661	-0.1090	-0.0258	-0.1609	-0.1609	-0.1609	-0.1609	-0.1609	-0.1609	-0.1609
0.450	-0.1809	-0.1189	-0.0218	-0.1580	-0.1580	-0.1580	-0.1580	-0.1580	-0.1580	-0.1580
0.500	-0.1979	-0.1243	-0.0539	-0.1564	-0.1564	-0.1564	-0.1564	-0.1564	-0.1564	-0.1564
0.525	*****	-0.1346	-0.0599	-0.1581	-0.1581	-0.1581	-0.1581	-0.1581	-0.1581	-0.1581
0.550	-0.2127	-0.1461	-0.0653	-0.1577	-0.1577	-0.1577	-0.1577	-0.1577	-0.1577	-0.1577
0.575	*****	-0.1529	-0.0661	-0.1621	-0.1621	-0.1621	-0.1621	-0.1621	-0.1621	-0.1621
0.600	-0.2348	-0.1631	-0.0872	-0.1653	-0.1653	-0.1653	-0.1653	-0.1653	-0.1653	-0.1653
0.625	*****	*****	-0.0895	-0.1650	-0.1650	-0.1650	-0.1650	-0.1650	-0.1650	-0.1650
0.650	-0.2532	-0.1764	-0.1011	-0.1699	-0.1699	-0.1699	-0.1699	-0.1699	-0.1699	-0.1699
0.675	*****	-0.1988	-0.1167	-0.1781	-0.1781	-0.1781	-0.1781	-0.1781	-0.1781	-0.1781
0.700	-0.2695	-0.2198	-0.1283	-0.1837	-0.1837	-0.1837	-0.1837	-0.1837	-0.1837	-0.1837
0.725	*****	-0.2444	*****	-0.1940	-0.1940	-0.1940	-0.1940	-0.1940	-0.1940	-0.1940
0.750	-0.2832	-0.2697	*****	-0.2062	-0.2062	-0.2062	-0.2062	-0.2062	-0.2062	-0.2062
0.775	*****	-0.2965	-0.1949	-0.2277	-0.2277	-0.2277	-0.2277	-0.2277	-0.2277	-0.2277
0.800	-0.2912	-0.3257	-0.2318	-0.2509	-0.2509	-0.2509	-0.2509	-0.2509	-0.2509	-0.2509
0.825	*****	-0.3532	-0.2748	-0.2605	-0.2605	-0.2605	-0.2605	-0.2605	-0.2605	-0.2605
0.850	-0.2983	-0.3793	-0.3220	-0.3139	-0.3139	-0.3139	-0.3139	-0.3139	-0.3139	-0.3139
0.875	*****	-0.4066	-0.3791	-0.3690	-0.3690	-0.3690	-0.3690	-0.3690	-0.3690	-0.3690
0.900	-0.3041	-0.4326	-0.4380	-0.4420	-0.4420	-0.4420	-0.4420	-0.4420	-0.4420	-0.4420
0.925	*****	-0.4612	-0.4918	-0.5145	-0.5145	-0.5145	-0.5145	-0.5145	-0.5145	-0.5145
0.950	-0.3126	-0.4829	-0.5486	-0.5918	-0.5918	-0.5918	-0.5918	-0.5918	-0.5918	-0.5918
0.975	*****	-0.5445	-0.6193	-0.6937	-0.7311	-0.7311	-0.7311	-0.7311	-0.7311	-0.7311
1.000	-0.2333	-0.5698	-0.6123	-0.9307	-0.9307	-0.9307	-0.9307	-0.9307	-0.9307	-0.9307
-0.200	$C_{p,l}$	$C_{p,l}$	$C_{p,l}$	$C_{p,l}$	$C_{p,l}$	$C_{p,l}$	$C_{p,l}$	$C_{p,l}$	$C_{p,l}$	$C_{p,l}$
-0.400	0.1087	0.1142	0.1688	0.1688	0.1688	0.1688	0.1688	0.1688	0.1688	0.1688
-0.600	0.0984	0.1197	0.1380	0.1380	0.1380	0.1380	0.1380	0.1380	0.1380	0.1380
-0.700	0.1077	0.1187	0.1275	0.1275	0.1275	0.1275	0.1275	0.1275	0.1275	0.1275
-0.800	0.1259	0.1120	0.1237	0.0291	0.0291	0.0291	0.0291	0.0291	0.0291	0.0291
-0.850	0.1586	*****	0.1199	0.0464	0.0464	0.0464	0.0464	0.0464	0.0464	0.0464
-0.900	*****	0.1474	0.1263	0.0520	0.0520	0.0520	0.0520	0.0520	0.0520	0.0520
-0.950	0.2365	0.1781	0.1499	0.0730	0.0730	0.0730	0.0730	0.0730	0.0730	0.0730
-0.975	0.2365	0.2146	0.1948	0.1279	0.1279	0.1279	0.1279	0.1279	0.1279	0.1279
-1.000	0.2203	0.2203	0.2094	0.1589	0.1589	0.1589	0.1589	0.1589	0.1589	0.1589
-1.000	-0.2435	-0.4859	-0.8037	-0.8571	-0.8571	-0.8571	-0.8571	-0.8571	-0.8571	-0.8571

Medium Radius L.E.
 Run No. = 19, Point No. = 376
 $C_N = 0.235$, $C_m = -0.0375$
 $\alpha = 6.0^\circ$, $M_\infty = 0.849$
 $R_{mac} = 72.2 \times 10^6$

Leading Edge Pressures



x/c_R	starb'd C_p	port C_p
0.10	-0.0232	*****
0.20	-0.2333	-0.2435
0.30	-0.4278	*****
0.40	-0.5698	-0.4859
0.50	-0.7526	*****
0.60	-0.6123	-0.8037
0.70	-0.6023	*****
0.80	-0.9307	-0.8571
0.90	*****	*****
0.95	-0.7919	-0.6808

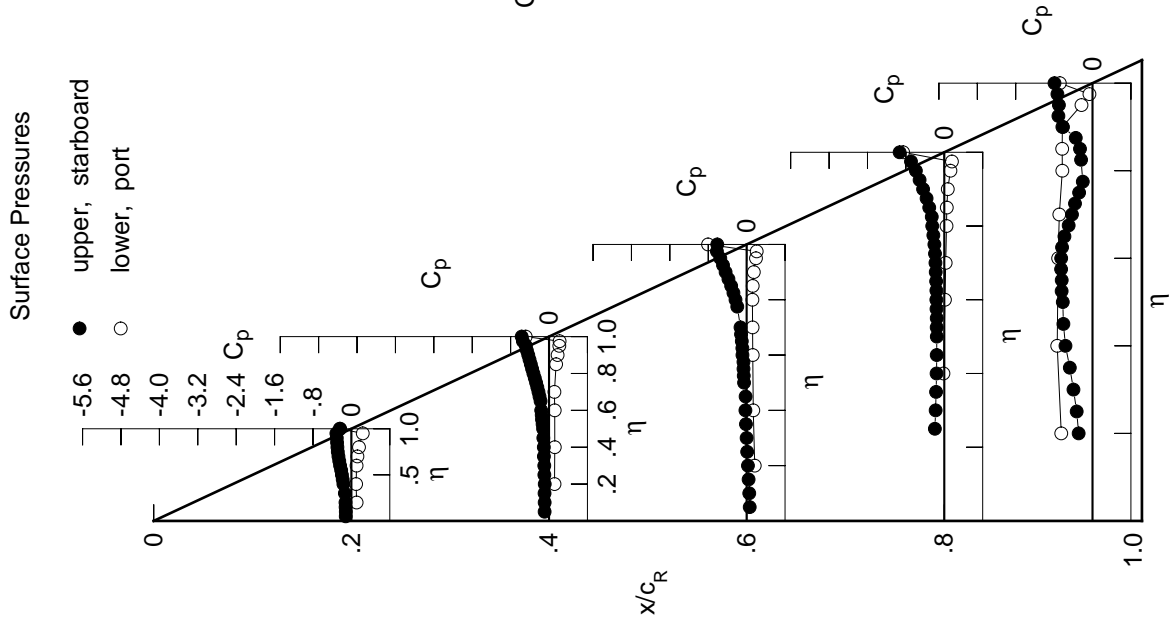
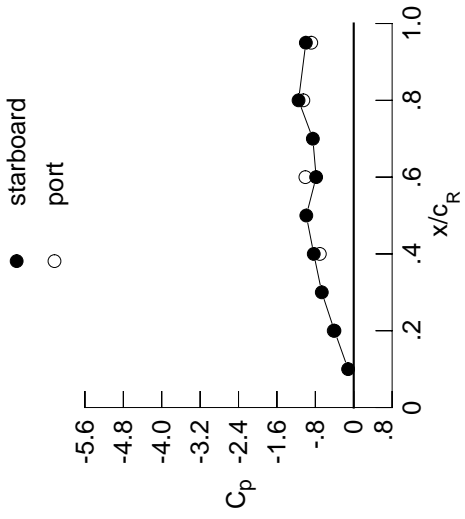

Table E7. Continued.

η	$x/c_R = .2$		$x/c_R = .4$		$x/c_R = .6$		$x/c_R = .8$		$x/c_R = .95$	
	$C_{p,u}$	$C_{p,u}$	$C_{p,u}$	$C_{p,u}$	$C_{p,u}$	$C_{p,u}$	$C_{p,u}$	$C_{p,u}$	$C_{p,u}$	$C_{p,u}$
0.050	-0.1336	-0.1072	0.0523	0.0523	0.0523	0.0523	0.0523	0.0523	0.0523	0.0523
0.100	-0.1343	-0.1083	0.0431	0.0431	0.0431	0.0431	0.0431	0.0431	0.0431	0.0431
0.150	-0.1389	-0.1099	0.0293	0.0293	0.0293	0.0293	0.0293	0.0293	0.0293	0.0293
0.200	-0.1425	-0.1067	0.0160	0.0160	0.0160	0.0160	0.0160	0.0160	0.0160	0.0160
0.250	*****	-0.1147	-0.0013	-0.0013	-0.0013	-0.0013	-0.0013	-0.0013	-0.0013	-0.0013
0.300	-0.1564	-0.1171	-0.0131	-0.0131	-0.0131	-0.0131	-0.0131	-0.0131	-0.0131	-0.0131
0.350	*****	-0.1252	-0.0281	-0.0281	-0.0281	-0.0281	-0.0281	-0.0281	-0.0281	-0.0281
0.400	-0.1872	-0.1282	-0.0400	-0.0400	-0.0400	-0.0400	-0.0400	-0.0400	-0.0400	-0.0400
0.450	-0.2037	-0.1398	-0.0369	-0.0369	-0.0369	-0.0369	-0.0369	-0.0369	-0.0369	-0.0369
0.500	-0.2237	-0.1458	-0.0702	-0.0702	-0.0702	-0.0702	-0.0702	-0.0702	-0.0702	-0.0702
0.525	*****	-0.1575	-0.0767	-0.0767	-0.0767	-0.0767	-0.0767	-0.0767	-0.0767	-0.0767
0.550	-0.2413	-0.1700	-0.0831	-0.0831	-0.0831	-0.0831	-0.0831	-0.0831	-0.0831	-0.0831
0.575	*****	-0.1777	-0.0844	-0.0844	-0.0844	-0.0844	-0.0844	-0.0844	-0.0844	-0.0844
0.600	-0.2666	-0.1893	-0.1077	-0.1077	-0.1077	-0.1077	-0.1077	-0.1077	-0.1077	-0.1077
0.625	*****	*****	-0.1113	-0.1113	-0.1113	-0.1113	-0.1113	-0.1113	-0.1113	-0.1113
0.650	-0.2891	-0.2057	-0.1258	-0.1258	-0.1258	-0.1258	-0.1258	-0.1258	-0.1258	-0.1258
0.675	*****	-0.2299	-0.1437	-0.1437	-0.1437	-0.1437	-0.1437	-0.1437	-0.1437	-0.1437
0.700	-0.3101	-0.2533	-0.1592	-0.1592	-0.1592	-0.1592	-0.1592	-0.1592	-0.1592	-0.1592
0.725	*****	-0.2807	*****	*****	-0.2379	-0.2379	-0.2379	-0.2379	-0.2379	-0.2379
0.750	-0.3295	-0.3091	*****	*****	-0.2529	-0.2529	-0.2529	-0.2529	-0.2529	-0.2529
0.775	*****	-0.3414	-0.2347	-0.2347	-0.2706	-0.2706	-0.2706	-0.2706	-0.2706	-0.2706
0.800	-0.3447	-0.3747	-0.2711	-0.2711	-0.2925	-0.2925	-0.2925	-0.2925	-0.2925	-0.2925
0.825	*****	-0.4092	-0.3155	-0.3155	-0.3036	-0.3036	-0.3036	-0.3036	-0.3036	-0.3036
0.850	-0.3596	-0.4430	-0.3666	-0.3666	-0.3453	-0.3453	-0.3453	-0.3453	-0.3453	-0.3453
0.875	*****	-0.4802	-0.4285	-0.4285	-0.3995	-0.3995	-0.3995	-0.3995	-0.3995	-0.3995
0.900	-0.3791	-0.5186	-0.4974	-0.4974	-0.4843	-0.4843	-0.4843	-0.4843	-0.4843	-0.4843
0.925	*****	-0.5613	-0.5663	-0.5663	-0.5736	-0.5736	-0.5736	-0.5736	-0.5736	-0.5736
0.950	-0.4042	-0.5983	-0.6417	-0.6417	-0.6748	-0.6748	-0.6748	-0.6748	-0.6748	-0.6748
0.975	*****	-0.6923	-0.7263	-0.7263	-0.8024	-0.8024	-0.8024	-0.8024	-0.8024	-0.8024
1.000	-0.4014	-0.8325	-0.7831	-0.7831	-1.1498	-1.1498	-1.1498	-1.1498	-1.1498	-1.1498
-0.200	$C_{p,l}$	0.1309	0.1340	0.1834	0.1834	0.1834	0.1834	0.1834	0.1834	0.1834
-0.400		0.1228	0.1394	0.1538	0.1538	0.0034	0.0034	-0.7231	-0.7231	-0.7231
-0.600		0.1349	0.1411	0.1448	0.1448	0.0282	0.0282	-0.7038	-0.7038	-0.7038
-0.700		0.1545	0.1369	0.1434	0.1434	0.0447	0.0447	-0.6790	-0.6790	-0.6790
-0.800		0.1867	*****	0.1425	0.1425	0.0654	0.0654	-0.6145	-0.6145	-0.6145
-0.850		*****	0.1755	0.1517	0.1517	0.0736	0.0736	-0.6155	-0.6155	-0.6155
-0.900		*****	0.2035	0.1746	0.1746	0.0971	0.0971	-0.6046	-0.6046	-0.6046
-0.950		0.2461	0.2281	0.2099	0.2099	0.1463	0.1463	-0.2206	-0.2206	-0.2206
-0.975		*****	0.2127	0.2059	0.2059	0.1607	0.1607	-0.0641	-0.0641	-0.0641
-1.000		-0.4166	-0.7063	-1.0076	-1.0076	-1.0500	-1.0500	-0.8849	-0.8849	-0.8849

Medium Radius L.E.
 Run No. = 19, Point No. = 377
 $C_N = 0.280$, $C_m = -0.0450$
 $\alpha = 7.1^\circ$, $M_\infty = 0.848$
 $R_{mac} = 72.2 \times 10^6$

Leading Edge Pressures



x/c_R	starb'd C_p	port C_p
0.10	-0.1168	*****
0.20	-0.4014	-0.4166
0.30	-0.6659	*****
0.40	-0.8325	-0.7063
0.50	-0.9883	*****
0.60	-0.7831	-1.0076
0.70	-0.8519	*****
0.80	-1.1498	-1.0500
0.90	*****	*****
0.95	-0.9978	-0.8849

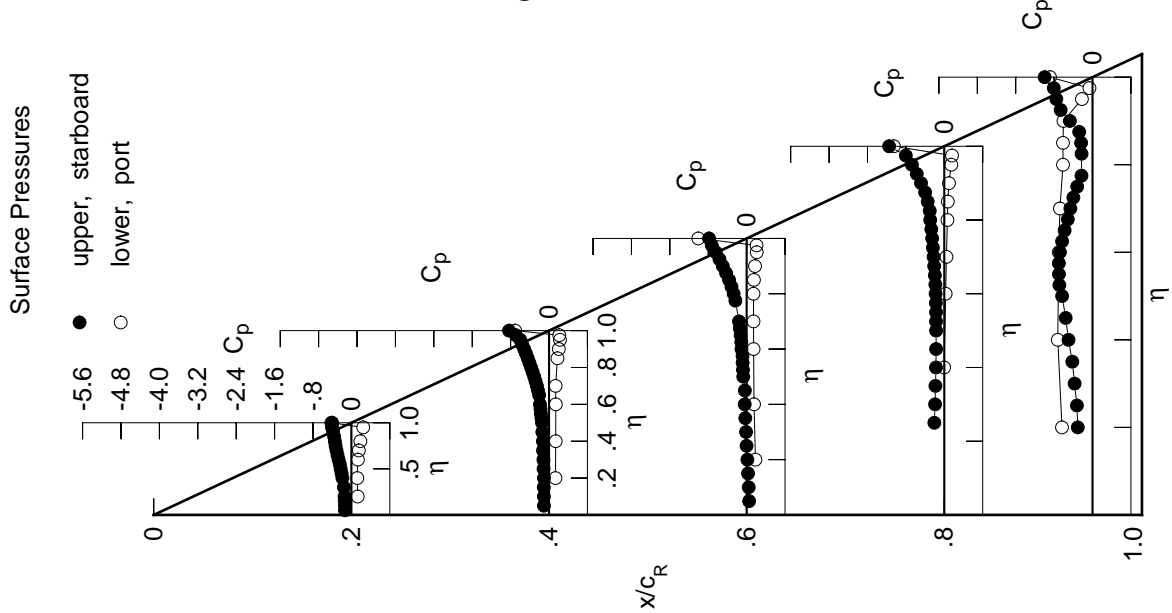
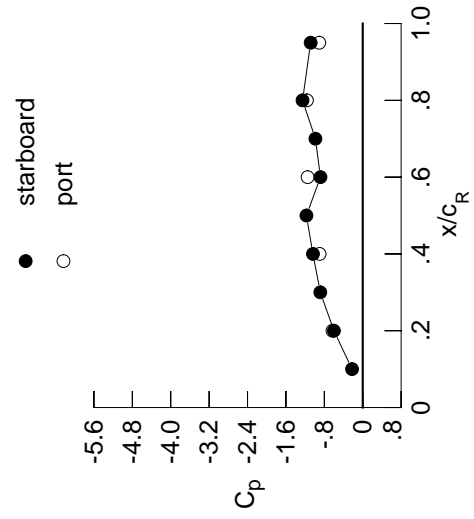

Table E7. Continued.

η	$x/c_R = .2$		$x/c_R = .4$		$x/c_R = .6$		$x/c_R = .8$		$x/c_R = .95$	
	$C_{p,u}$	$C_{p,u}$	$C_{p,u}$	$C_{p,u}$	$C_{p,u}$	$C_{p,u}$	$C_{p,u}$	$C_{p,u}$	$C_{p,u}$	$C_{p,u}$
0.050	-0.1495	-0.1237	0.0404	*****	*****	*****	*****	*****	*****	*****
0.100	-0.1524	-0.1255	0.0295	*****	*****	*****	*****	*****	*****	*****
0.150	-0.1568	-0.1276	0.0165	*****	*****	*****	*****	*****	*****	*****
0.200	-0.1611	-0.1247	0.0016	*****	*****	*****	*****	*****	*****	*****
0.250	*****	-0.1327	-0.0154	-0.2271	-0.3115	*****	*****	*****	*****	*****
0.300	-0.1757	-0.1356	-0.0282	-0.2217	-0.3451	*****	*****	*****	*****	*****
0.350	*****	-0.1453	-0.0433	-0.2034	-0.4172	*****	*****	*****	*****	*****
0.400	-0.2098	-0.1490	-0.0557	-0.1911	-0.6283	*****	*****	*****	*****	*****
0.450	-0.2277	-0.1616	-0.0544	-0.1893	-0.7623	*****	*****	*****	*****	*****
0.500	-0.2494	-0.1687	-0.0882	-0.1924	-0.7601	*****	*****	*****	*****	*****
0.525	*****	-0.1817	-0.0975	-0.1979	-0.7528	*****	*****	*****	*****	*****
0.550	-0.2699	-0.1961	-0.1088	-0.2007	-0.7214	*****	*****	*****	*****	*****
0.575	*****	-0.2073	-0.1157	-0.2098	-0.7031	*****	*****	*****	*****	*****
0.600	-0.2983	-0.2216	-0.1436	-0.2184	-0.6734	*****	*****	*****	*****	*****
0.625	*****	*****	-0.1498	-0.2242	-0.6270	*****	*****	*****	*****	*****
0.650	-0.3251	-0.2401	-0.1669	-0.2342	-0.5845	*****	*****	*****	*****	*****
0.675	*****	-0.2662	-0.1860	-0.2468	-0.5430	*****	*****	*****	*****	*****
0.700	-0.3511	-0.2897	-0.2013	-0.2656	-0.5258	*****	*****	*****	*****	*****
0.725	*****	-0.3193	*****	-0.2949	-0.5285	*****	*****	*****	*****	*****
0.750	-0.3771	-0.3492	*****	-0.3126	-0.5242	*****	*****	*****	*****	*****
0.775	*****	-0.3850	-0.2720	-0.3108	-0.5304	*****	*****	*****	*****	*****
0.800	-0.3986	-0.4231	-0.3086	-0.3251	*****	*****	*****	*****	*****	*****
0.825	*****	-0.4651	-0.3516	-0.3742	-0.5872	*****	*****	*****	*****	*****
0.850	-0.4237	-0.5056	-0.4047	-0.4836	-0.6021	*****	*****	*****	*****	*****
0.875	*****	-0.5509	-0.4698	-0.4545	-0.7201	*****	*****	*****	*****	*****
0.900	-0.4554	-0.5998	-0.5472	-0.5416	-0.6885	*****	*****	*****	*****	*****
0.925	*****	-0.6561	-0.6515	-0.6833	-0.8528	*****	*****	*****	*****	*****
0.950	-0.5089	-0.7013	-0.8420	-0.7919	-0.7052	*****	*****	*****	*****	*****
0.975	*****	-0.8546	-1.1277	-1.0280	-0.7618	*****	*****	*****	*****	*****
1.000	-0.6000	-1.0371	-0.8803	-1.2542	-1.0850	*****	*****	*****	*****	*****
-0.200	$C_{p,l}$	$C_{p,l}$	$C_{p,l}$	$C_{p,l}$	$C_{p,l}$	$C_{p,l}$	$C_{p,l}$	$C_{p,l}$	$C_{p,l}$	$C_{p,l}$
-0.400	0.1569	0.1557	0.2011	*****	*****	*****	*****	*****	*****	*****
-0.600	0.1488	0.1620	0.1717	0.0140	-0.7162	*****	*****	*****	*****	*****
-0.700	0.1633	0.1657	0.1648	0.0457	-0.6918	*****	*****	*****	*****	*****
-0.800	0.1837	0.1631	0.1644	0.0638	-0.6646	*****	*****	*****	*****	*****
-0.850	0.2139	*****	0.1656	0.0852	-0.5964	*****	*****	*****	*****	*****
-0.900	*****	0.2028	0.1761	0.0952	-0.5966	*****	*****	*****	*****	*****
-0.950	*****	0.2270	0.1978	0.1199	-0.5787	*****	*****	*****	*****	*****
-0.975	0.2499	0.2377	0.2214	0.1623	-0.2048	*****	*****	*****	*****	*****
-1.000	0.2004	0.2004	0.1991	0.1623	-0.0543	*****	*****	*****	*****	*****
	-0.6299	-0.8987	-1.1484	-1.1635	-0.9060	*****	*****	*****	*****	*****

Medium Radius L.E.
 Run No. = 19, Point No. = 378
 $C_N = 0.338$, $C_m = -0.0591$
 $\alpha = 8.1^\circ$, $M_\infty = 0.849$
 $R_{mac} = 72.3 \times 10^6$

Leading Edge Pressures



x/c_R	starb'd C_p	port C_p
0.10	-0.2227	*****
0.20	-0.6000	-0.6299
0.30	-0.8843	*****
0.40	-1.0371	-0.8987
0.50	-1.1731	*****
0.60	-0.8803	-1.1484
0.70	-0.9854	*****
0.80	-1.2542	-1.1635
0.90	*****	*****
0.95	-1.0850	-0.9060

Surface Pressures

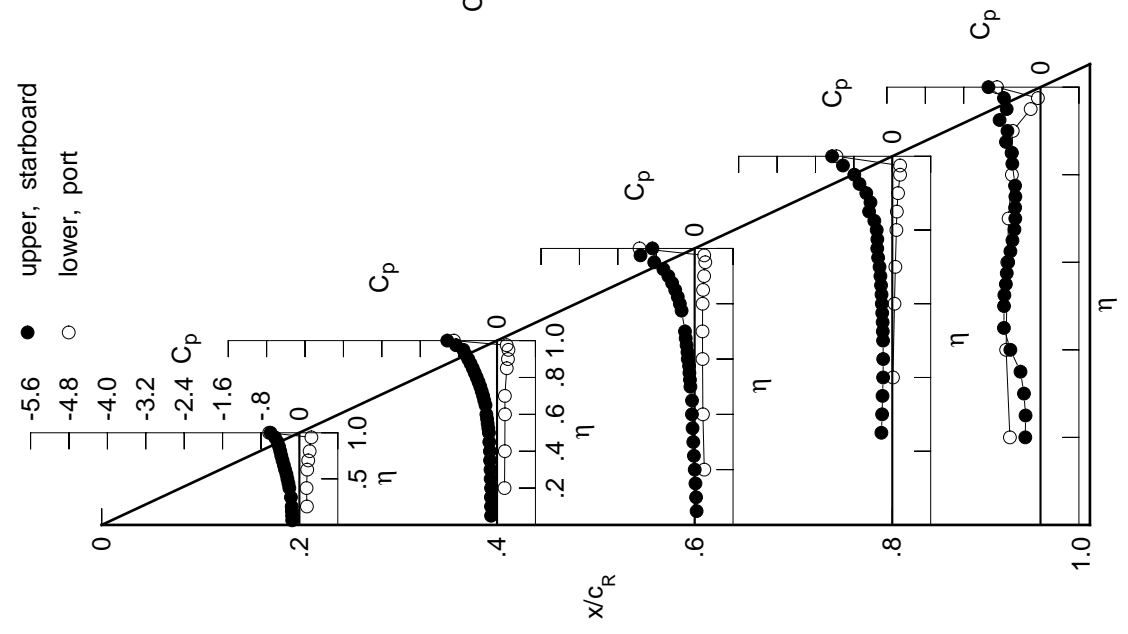
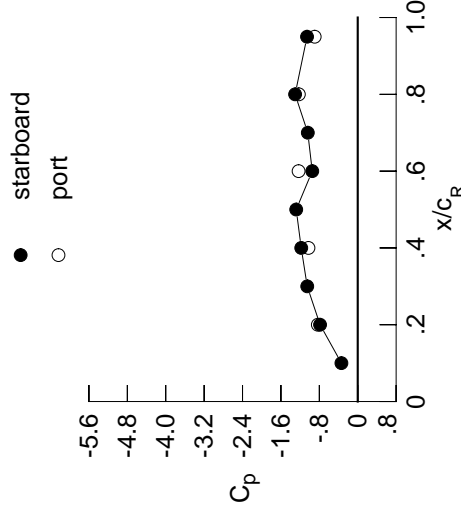

Table E7. Continued.

η	$x/c_R = .2$		$x/c_R = .4$		$x/c_R = .6$		$x/c_R = .8$		$x/c_R = .95$	
	$C_{p,u}$	$C_{p,u}$	$C_{p,u}$	$C_{p,u}$	$C_{p,u}$	$C_{p,u}$	$C_{p,u}$	$C_{p,u}$	$C_{p,u}$	$C_{p,u}$
0.050	-0.1665	-0.1432	0.0220	0.0220	0.0220	0.0220	0.0220	0.0220	0.0220	0.0220
0.100	-0.1713	-0.1453	0.0115	0.0115	0.0115	0.0115	0.0115	0.0115	0.0115	0.0115
0.150	-0.1774	-0.1474	-0.0031	-0.0031	-0.0031	-0.0031	-0.0031	-0.0031	-0.0031	-0.0031
0.200	-0.1823	-0.1466	-0.0175	-0.0175	-0.0175	-0.0175	-0.0175	-0.0175	-0.0175	-0.0175
0.250	*****	-0.1547	-0.0361	-0.0361	-0.0361	-0.0361	-0.0361	-0.0361	-0.0361	-0.0361
0.300	-0.1978	-0.1590	-0.0474	-0.0474	-0.0474	-0.0474	-0.0474	-0.0474	-0.0474	-0.0474
0.350	*****	-0.1682	-0.0626	-0.0626	-0.0626	-0.0626	-0.0626	-0.0626	-0.0626	-0.0626
0.400	-0.2333	-0.1723	-0.0718	-0.0718	-0.0718	-0.0718	-0.0718	-0.0718	-0.0718	-0.0718
0.450	-0.2528	-0.1866	-0.0780	-0.0780	-0.0780	-0.0780	-0.0780	-0.0780	-0.0780	-0.0780
0.500	-0.2765	-0.1994	-0.1280	-0.1280	-0.1280	-0.1280	-0.1280	-0.1280	-0.1280	-0.1280
0.525	*****	-0.2156	-0.1412	-0.1412	-0.1412	-0.1412	-0.1412	-0.1412	-0.1412	-0.1412
0.550	-0.2998	-0.2348	-0.1532	-0.1532	-0.1532	-0.1532	-0.1532	-0.1532	-0.1532	-0.1532
0.575	*****	-0.2486	-0.1610	-0.1610	-0.1610	-0.1610	-0.1610	-0.1610	-0.1610	-0.1610
0.600	-0.3316	-0.2644	-0.1883	-0.1883	-0.1883	-0.1883	-0.1883	-0.1883	-0.1883	-0.1883
0.625	*****	*****	-0.1905	-0.1905	-0.1905	-0.1905	-0.1905	-0.1905	-0.1905	-0.1905
0.650	-0.3624	-0.2817	-0.2065	-0.2065	-0.2065	-0.2065	-0.2065	-0.2065	-0.2065	-0.2065
0.675	*****	-0.3039	-0.2305	-0.2305	-0.2305	-0.2305	-0.2305	-0.2305	-0.2305	-0.2305
0.700	-0.3950	-0.3260	-0.2449	-0.2449	-0.2449	-0.2449	-0.2449	-0.2449	-0.2449	-0.2449
0.725	*****	-0.3545	*****	*****	-0.2982	-0.2982	-0.2982	-0.2982	-0.2982	-0.2982
0.750	-0.4267	-0.3852	*****	*****	-0.2988	-0.2988	-0.2988	-0.2988	-0.2988	-0.2988
0.775	*****	-0.4228	-0.3470	-0.3470	-0.3455	-0.3455	-0.3455	-0.3455	-0.3455	-0.3455
0.800	-0.4568	-0.4652	-0.4070	-0.4070	-0.4075	-0.4075	-0.4075	-0.4075	-0.4075	-0.4075
0.825	*****	-0.5104	-0.4088	-0.4088	-0.7076	-0.7076	-0.6244	-0.6244	-0.6244	-0.6244
0.850	-0.4904	-0.5564	-0.4396	-0.4396	-0.7130	-0.7130	-0.6503	-0.6503	-0.6503	-0.6503
0.875	*****	-0.6055	-0.6002	-0.6002	-0.5628	-0.5628	-0.6935	-0.6935	-0.6935	-0.6935
0.900	-0.5363	-0.6640	-0.6897	-0.6897	-0.5331	-0.5331	-0.7048	-0.7048	-0.7048	-0.7048
0.925	*****	-0.7187	-0.8866	-0.8866	-0.7902	-0.7902	-0.6515	-0.6515	-0.6515	-0.6515
0.950	-0.6109	-0.8736	-0.9378	-0.9378	-0.9506	-0.9506	-0.5322	-0.5322	-0.5322	-0.5322
0.975	*****	-1.2320	-1.2514	-1.2514	-0.8398	-0.8398	-0.7530	-0.7530	-0.7530	-0.7530
1.000	-0.7846	-1.1772	-0.9476	-0.9476	-1.3049	-1.3049	-1.0561	-1.0561	-1.0561	-1.0561
-0.200	$C_{p,l}$	$C_{p,l}$	$C_{p,l}$	$C_{p,l}$	$C_{p,l}$	$C_{p,l}$	$C_{p,l}$	$C_{p,l}$	$C_{p,l}$	$C_{p,l}$
-0.400	0.1797	0.1768	0.2162	0.2162	0.2162	0.2162	0.2162	0.2162	0.2162	0.2162
-0.600	0.1739	0.1839	0.1887	0.1887	0.0282	0.0282	-0.7075	-0.7075	-0.7075	-0.7075
-0.700	0.1907	0.1887	0.1831	0.1831	0.0604	0.0604	-0.6813	-0.6813	-0.6813	-0.6813
-0.800	0.2109	0.1915	0.1830	0.1830	0.0788	0.0788	-0.6540	-0.6540	-0.6540	-0.6540
-0.850	0.2393	*****	0.1864	0.1864	0.1018	0.1018	-0.5837	-0.5837	-0.5837	-0.5837
-0.900	*****	0.2276	0.1971	0.1971	0.1129	0.1129	-0.5823	-0.5823	-0.5823	-0.5823
-0.950	*****	0.2468	0.2161	0.2161	0.1380	0.1380	-0.5578	-0.5578	-0.5578	-0.5578
-0.975	0.2504	0.2437	0.2272	0.2272	0.1723	0.1723	-0.1958	-0.1958	-0.1958	-0.1958
-1.000	*****	0.1854	0.1872	0.1872	0.1587	0.1587	-0.0516	-0.0516	-0.0516	-0.0516
-1.000	-0.8309	-1.0266	-1.2324	-1.2324	-1.2260	-1.2260	-0.8966	-0.8966	-0.8966	-0.8966

Medium Radius L.E.
 Run No. = 19, Point No. = 379
 $C_N = 0.391$, $C_m = -0.0684$
 $\alpha = 9.2^\circ$, $M_\infty = 0.849$
 $R_{mac} = 72.2 \times 10^6$

Leading Edge Pressures



x/c_R	starb'd C_p	port C_p
0.10	-0.3396	*****
0.20	-0.7846	-0.8309
0.30	-1.0523	*****
0.40	-1.1772	-1.0266
0.50	-1.2815	*****
0.60	-0.9476	-1.2324
0.70	-1.0403	*****
0.80	-1.3049	-1.2260
0.90	*****	*****
0.95	-1.0561	-0.8966

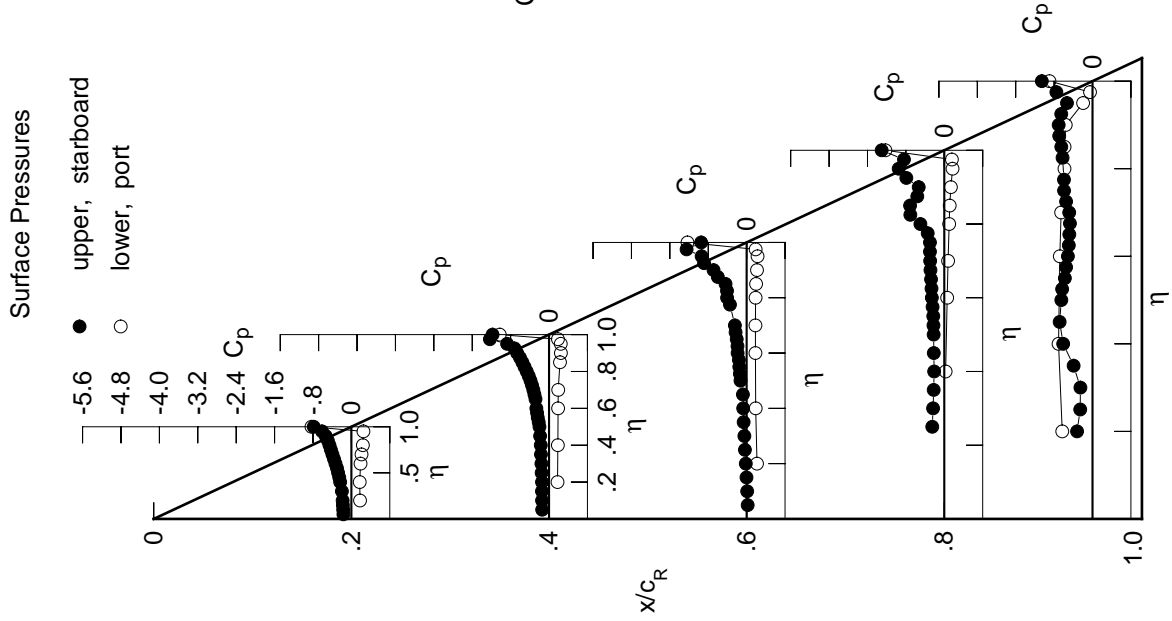

Table E7. Continued.

η	$x/c_R = .2$		$x/c_R = .4$		$x/c_R = .6$		$x/c_R = .8$		$x/c_R = .95$	
	$C_{p,u}$	$C_{p,u}$	$C_{p,u}$	$C_{p,u}$	$C_{p,u}$	$C_{p,u}$	$C_{p,u}$	$C_{p,u}$	$C_{p,u}$	$C_{p,u}$
0.050	-0.1986	-0.1999	-0.0282	*****	*****	*****	*****	*****	*****	*****
0.100	-0.2069	-0.2028	-0.0397	*****	*****	*****	*****	*****	*****	*****
0.150	-0.2173	-0.2053	-0.0568	*****	*****	*****	*****	*****	*****	*****
0.200	-0.2244	-0.2063	-0.0676	*****	*****	*****	*****	*****	*****	*****
0.250	*****	-0.2124	-0.0835	-0.3092	-0.2502	*****	*****	*****	*****	*****
0.300	-0.2451	-0.2133	-0.1021	-0.2919	-0.3798	*****	*****	*****	*****	*****
0.350	*****	-0.2338	-0.1241	-0.2828	-0.4607	*****	*****	*****	*****	*****
0.400	-0.2833	-0.2529	-0.1466	-0.2792	-0.5230	*****	*****	*****	*****	*****
0.450	-0.3064	-0.2753	-0.1673	-0.2676	-0.6228	*****	*****	*****	*****	*****
0.500	-0.3350	-0.2930	-0.2061	-0.2543	-0.7216	*****	*****	*****	*****	*****
0.525	*****	-0.3068	-0.2034	-0.2504	-0.7232	*****	*****	*****	*****	*****
0.550	-0.3638	-0.3190	-0.2033	-0.2466	-0.7071	*****	*****	*****	*****	*****
0.575	*****	-0.3232	-0.2051	-0.2556	-0.7065	*****	*****	*****	*****	*****
0.600	-0.4013	-0.3352	-0.2514	-0.2746	-0.7028	*****	*****	*****	*****	*****
0.625	*****	*****	-0.2917	-0.3066	-0.7338	*****	*****	*****	*****	*****
0.650	-0.4411	-0.3895	-0.3719	-0.4017	-0.8324	*****	*****	*****	*****	*****
0.675	*****	-0.4197	-0.4346	-0.5787	-0.9594	*****	*****	*****	*****	*****
0.700	-0.4838	-0.4332	-0.4805	-0.7791	-1.0703	*****	*****	*****	*****	*****
0.725	*****	-0.4441	*****	-0.9308	-1.0971	*****	*****	*****	*****	*****
0.750	-0.5378	-0.4439	*****	-0.9837	-1.0361	*****	*****	*****	*****	*****
0.775	*****	-0.4415	-0.7835	-1.0011	-0.8808	*****	*****	*****	*****	*****
0.800	-0.5822	-0.4820	-0.8364	-0.9394	*****	*****	*****	*****	*****	*****
0.825	*****	-0.8087	-0.8764	-0.9029	-0.6708	*****	*****	*****	*****	*****
0.850	-0.6284	-1.0417	-0.9176	-0.8432	-0.6008	*****	*****	*****	*****	*****
0.875	*****	-1.1117	-0.9587	-0.7914	-0.5600	*****	*****	*****	*****	*****
0.900	-0.6898	-1.0459	-0.9477	-0.7711	-0.5319	*****	*****	*****	*****	*****
0.925	*****	-1.1270	-0.9470	-0.7555	-0.4969	*****	*****	*****	*****	*****
0.950	-0.9455	-1.2544	-0.9302	-0.7225	-0.4297	*****	*****	*****	*****	*****
0.975	*****	-1.2371	-0.8859	-0.6573	-0.3723	*****	*****	*****	*****	*****
1.000	-1.0584	-1.3300	-0.9277	-1.1243	-0.5531	*****	*****	*****	*****	*****
-0.200	$C_{p,l}$	$C_{p,l}$	$C_{p,l}$	$C_{p,l}$	$C_{p,l}$	$C_{p,l}$	$C_{p,l}$	$C_{p,l}$	$C_{p,l}$	$C_{p,l}$
-0.400	0.2380	0.2282	0.2557	*****	-0.6152	*****	*****	*****	*****	*****
-0.600	0.2355	0.2360	0.2294	0.0616	-0.6854	*****	*****	*****	*****	*****
-0.700	0.2542	0.2429	0.2254	0.0935	-0.6577	*****	*****	*****	*****	*****
-0.800	0.2736	0.2449	0.2280	0.1131	-0.6290	*****	*****	*****	*****	*****
-0.850	0.2942	*****	0.2333	0.1359	-0.5570	*****	*****	*****	*****	*****
-0.900	*****	0.2795	0.2433	0.1477	-0.5518	*****	*****	*****	*****	*****
-0.950	0.2484	0.2569	0.2476	0.1890	-0.1760	*****	*****	*****	*****	*****
-0.975	*****	0.1628	0.1830	0.1541	-0.0447	*****	*****	*****	*****	*****
-1.000	-1.1072	-1.1419	-1.1930	-1.1423	-0.6483	*****	*****	*****	*****	*****

Medium Radius L.E.
 Run No. = 19, Point No. = 380
 $C_N = 0.525$, $C_m = -0.0937$
 $\alpha = 11.3^\circ$, $M_\infty = 0.852$
 $R_{mac} = 72.4 \times 10^6$

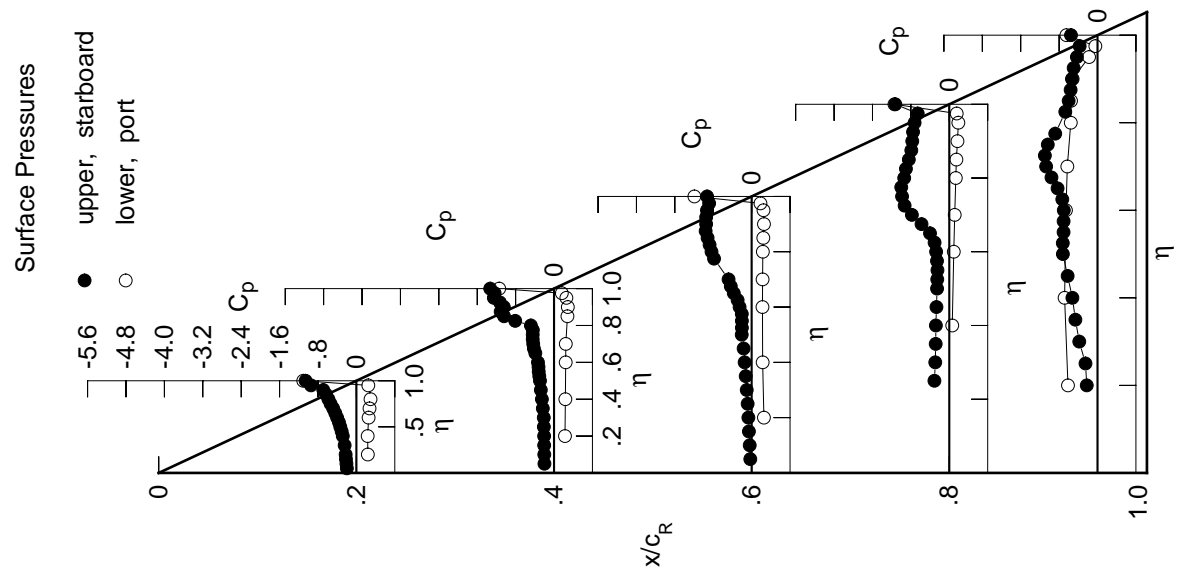
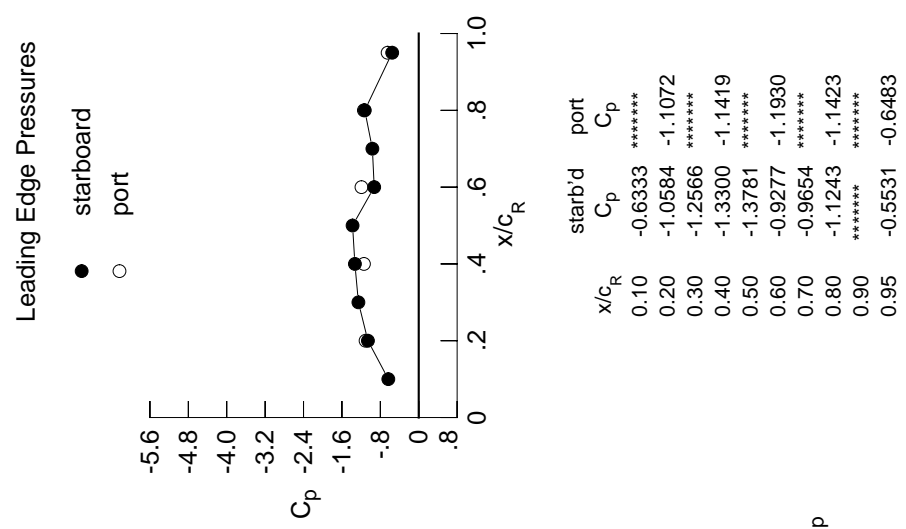
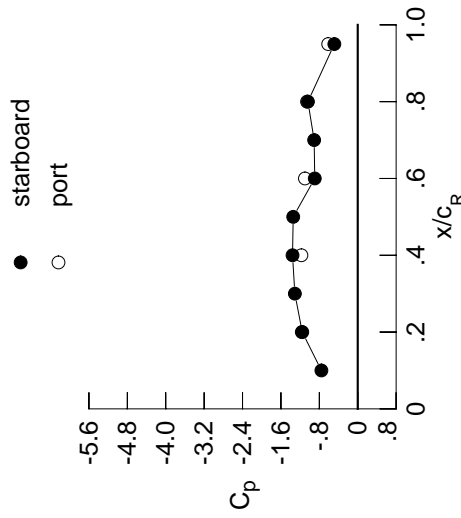

Table E7. Continued.

η	x/c_R .2	x/c_R .4	x/c_R .6	x/c_R .8	x/c_R .95
	$C_{p,u}$	$C_{p,u}$	$C_{p,u}$	$C_{p,u}$	$C_{p,u}$
0.050	-0.2152	-0.2326	-0.0482	*****	*****
0.100	-0.2202	-0.2339	-0.0587	*****	*****
0.150	-0.2357	-0.2383	-0.0766	*****	*****
0.200	-0.2453	-0.2375	-0.0840	*****	-0.2593
0.250	*****	-0.2399	-0.1066	-0.3360	-0.2958
0.300	-0.2692	-0.2547	-0.1231	-0.3220	-0.3963
0.350	*****	-0.2786	-0.1544	-0.3106	-0.4623
0.400	-0.3134	-0.2992	-0.1650	-0.2946	-0.5961
0.450	-0.3369	-0.3263	-0.1568	-0.2861	-0.6622
0.500	-0.3642	-0.3426	-0.2017	-0.2755	-0.6610
0.525	*****	-0.3412	-0.2210	-0.2744	-0.6686
0.550	-0.3909	-0.3432	-0.2419	-0.2766	-0.6640
0.575	*****	-0.3457	-0.2693	-0.2963	-0.6874
0.600	-0.4305	-0.3544	-0.3623	-0.3469	-0.7313
0.625	*****	*****	-0.4208	-0.4446	-0.8328
0.650	-0.4755	-0.4038	-0.5488	-0.6220	-0.9832
0.675	*****	-0.5079	-0.6692	-0.8474	-1.1047
0.700	-0.5270	-0.6096	-0.7601	-1.0229	-1.1780
0.725	*****	-0.6246	*****	-1.1100	-1.1494
0.750	-0.5785	-0.6194	*****	-1.0792	-0.9785
0.775	*****	-0.6485	-0.9664	-1.0606	-0.7816
0.800	-0.6235	-0.7417	-0.9737	-0.9907	*****
0.825	*****	-1.0077	-0.9807	-0.9402	-0.6014
0.850	-0.6840	-1.1532	-0.9762	-0.8459	-0.5332
0.875	*****	-1.1865	-0.9759	-0.7801	-0.4997
0.900	-0.8712	-1.1264	-0.9523	-0.7614	-0.4829
0.925	*****	-1.1218	-0.9034	-0.7503	-0.4698
0.950	-1.2384	-1.2206	-0.8611	-0.7228	-0.4062
0.975	*****	-1.1863	-0.8293	-0.6429	-0.3444
1.000	-1.1559	-1.3585	-0.8953	-1.0374	-0.4871
	$C_{p,l}$	$C_{p,l}$	$C_{p,l}$	$C_{p,l}$	$C_{p,l}$
-0.200	0.2707	0.2552	0.2763	*****	-0.6008
-0.400	0.2679	0.2638	0.2507	0.0790	-0.6726
-0.600	0.2868	0.2703	0.2471	0.1115	-0.6464
-0.700	0.3047	0.2727	0.2503	0.1311	-0.6173
-0.800	0.3212	*****	0.2550	0.1539	-0.5435
-0.850	*****	0.3031	0.2643	0.1655	-0.5371
-0.900	*****	0.3046	0.2737	0.1856	-0.4991
-0.950	0.2472	0.2601	0.2521	0.1950	-0.1669
-0.975	*****	0.1487	0.1727	0.1465	-0.0450
-1.000	-1.1649	-1.1735	-1.1004	-1.0557	-0.6156

Medium Radius L.E.
 Run No. = 19, Point No. = 381
 $C_N = 0.585$, $C_m = -0.1028$
 $\alpha = 12.4^\circ$, $M_\infty = 0.852$
 $R_{mac} = 72.2 \times 10^6$

Leading Edge Pressures



x/c_R	starb'd C_p	port C_p
0.10	-0.7571	*****
0.20	-1.1559	-1.1649
0.30	-1.3099	*****
0.40	-1.3585	-1.1735
0.50	-1.3442	*****
0.60	-0.8953	-1.1004
0.70	-0.9079	*****
0.80	-1.0374	-1.0557
0.90	*****	*****
0.95	-0.4871	-0.6156

Surface Pressures

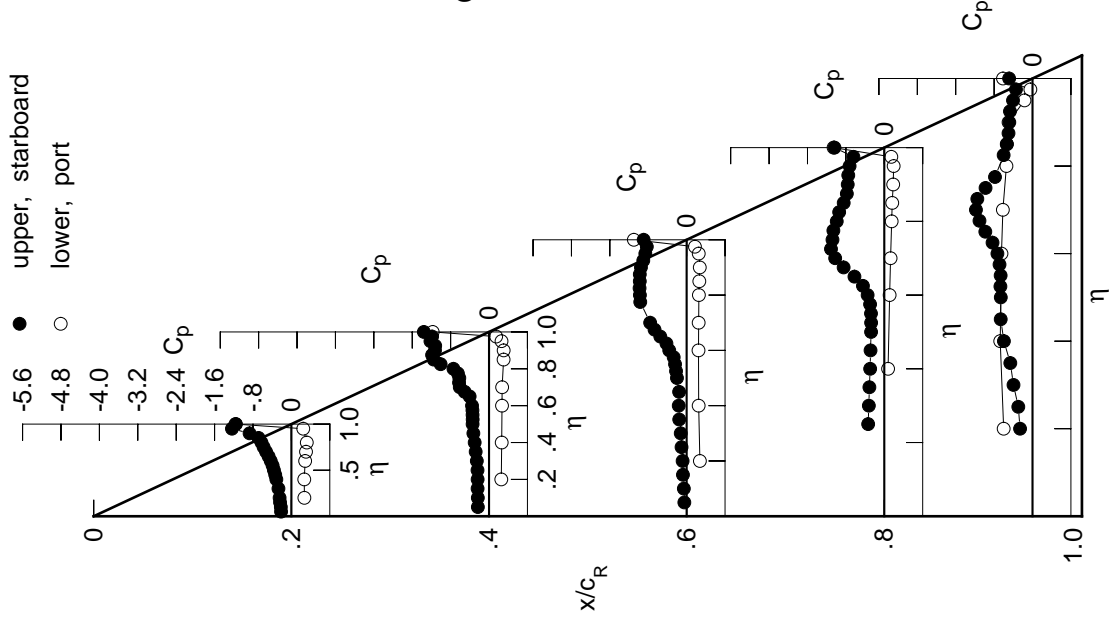
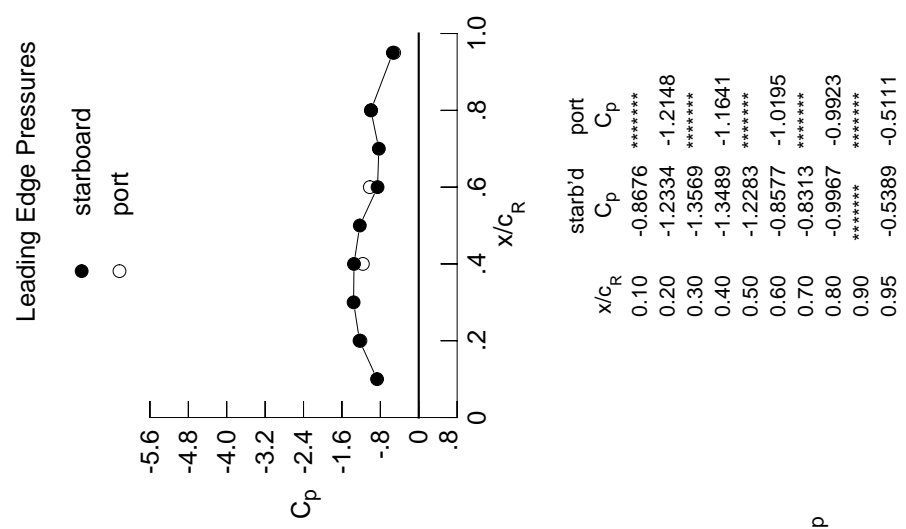

Table E7. Continued.

η	$x/c_R = .2$		$x/c_R = .4$		$x/c_R = .6$		$x/c_R = .8$		$x/c_R = .95$	
	$C_{p,u}$	$C_{p,u}$	$C_{p,u}$	$C_{p,u}$	$C_{p,u}$	$C_{p,u}$	$C_{p,u}$	$C_{p,u}$	$C_{p,u}$	$C_{p,u}$
0.050	-0.2417	-0.2713	-0.0722	*****	*****	*****	*****	*****	*****	
0.100	-0.2446	-0.2730	-0.0831	*****	*****	*****	*****	*****	*****	
0.150	-0.2601	-0.2749	-0.0979	*****	*****	*****	*****	*****	*****	
0.200	-0.2754	-0.2709	-0.1106	*****	*****	*****	*****	*****	-0.3053	
0.250	*****	-0.2791	-0.1299	-0.3641	-0.3536	-0.3881	*****	*****	-0.3158	
0.300	-0.3088	-0.2952	-0.1548	-0.3536	-0.3881	*****	*****	*****	-0.3881	
0.350	*****	-0.3265	-0.1918	-0.3462	-0.4269	*****	*****	*****	-0.4269	
0.400	-0.3548	-0.3446	-0.1966	-0.3269	-0.5040	*****	*****	*****	-0.5040	
0.450	-0.3718	-0.3827	-0.1806	-0.3138	-0.6444	*****	*****	*****	-0.6444	
0.500	-0.3961	-0.3914	-0.1929	-0.3017	-0.6737	*****	*****	*****	-0.6737	
0.525	*****	-0.3834	-0.1932	-0.3033	-0.6741	*****	*****	*****	-0.6741	
0.550	-0.4254	-0.3867	-0.1969	-0.3099	-0.6751	*****	*****	*****	-0.6751	
0.575	*****	-0.3861	-0.2085	-0.3422	-0.7096	*****	*****	*****	-0.7096	
0.600	-0.4677	-0.3857	-0.3252	-0.4105	-0.7728	*****	*****	*****	-0.7728	
0.625	*****	*****	-0.4788	-0.5390	-0.8912	*****	*****	*****	-0.8912	
0.650	-0.5132	-0.4163	-0.7608	-0.7417	-1.0575	*****	*****	*****	-1.0575	
0.675	*****	-0.5521	-1.0049	-0.9776	-1.2090	*****	*****	*****	-1.2090	
0.700	-0.5629	-0.7818	-1.1325	-1.1755	-0.9862	*****	*****	*****	-0.9862	
0.725	*****	-0.9410	*****	-1.3158	-0.8523	*****	*****	*****	-0.8523	
0.750	-0.6057	-1.0423	*****	-1.3774	-0.8089	*****	*****	*****	-0.8089	
0.775	*****	-1.1354	-1.1738	-1.2167	-0.7211	*****	*****	*****	-0.7211	
0.800	-0.6903	-1.1911	-1.1071	-0.9957	*****	*****	*****	*****	*****	
0.825	*****	-1.1894	-1.0708	-0.8777	-0.6005	*****	*****	*****	-0.6005	
0.850	-0.9906	-1.1848	-1.0409	-0.8358	-0.5532	*****	*****	*****	-0.5532	
0.875	*****	-1.1810	-1.0024	-0.8264	-0.5611	*****	*****	*****	-0.5611	
0.900	-1.2084	-1.1125	-0.9362	-0.8073	-0.5410	*****	*****	*****	-0.5410	
0.925	*****	-1.0752	-0.8779	-0.7218	-0.5404	*****	*****	*****	-0.5404	
0.950	-1.3160	-1.1672	-0.8354	-0.7391	-0.4876	*****	*****	*****	-0.4876	
0.975	*****	-1.1829	-0.8001	-0.6762	-0.4198	*****	*****	*****	-0.4198	
1.000	-1.2334	-1.3489	-0.8577	-0.9967	-0.5389	*****	*****	*****	-0.5389	
-0.200	$C_{p,l}$	$C_{p,l}$	$C_{p,l}$	$C_{p,l}$	$C_{p,l}$	$C_{p,l}$	$C_{p,l}$	$C_{p,l}$	$C_{p,l}$	
-0.400	0.2983	0.2777	0.2917	*****	-0.5921	*****	*****	*****	-0.5921	
-0.600	0.2967	0.2862	0.2666	0.0930	-0.6646	*****	*****	*****	-0.6646	
-0.700	0.3161	0.2932	0.2636	0.1242	-0.6382	*****	*****	*****	-0.6382	
-0.800	0.3320	0.2962	0.2672	0.1444	-0.6082	*****	*****	*****	-0.6082	
-0.850	0.3446	*****	0.2718	0.1660	-0.5326	*****	*****	*****	-0.5326	
-0.900	*****	0.3219	0.2798	0.1779	-0.5230	*****	*****	*****	-0.5230	
-0.950	*****	0.3172	0.2850	0.1956	-0.4807	*****	*****	*****	-0.4807	
-0.975	0.2438	0.2594	0.2508	0.1956	-0.1575	*****	*****	*****	-0.1575	
-1.000	*****	0.1329	0.1578	0.1339	-0.0417	*****	*****	*****	-0.0417	
	-1.2148	-1.1641	-1.0195	-0.9923	-0.5111	*****	*****	*****	-0.5111	

Medium Radius L.E.
 Run No. = 19, Point No. = 382
 $C_N = 0.646$, $C_m = -0.1117$
 $\alpha = 13.5^\circ$, $M_\infty = 0.853$
 $R_{mac} = 72.2 \times 10^6$



x/c_R	starb'd C_p	port C_p
0.10	-0.8676	*****
0.20	-1.2334	-1.2148
0.30	-1.3569	*****
0.40	-1.3489	-1.1641
0.50	-1.2283	*****
0.60	-0.8577	-1.0195
0.70	-0.8313	*****
0.80	-0.9967	-0.9923
0.90	*****	*****
0.95	-0.5389	-0.5111

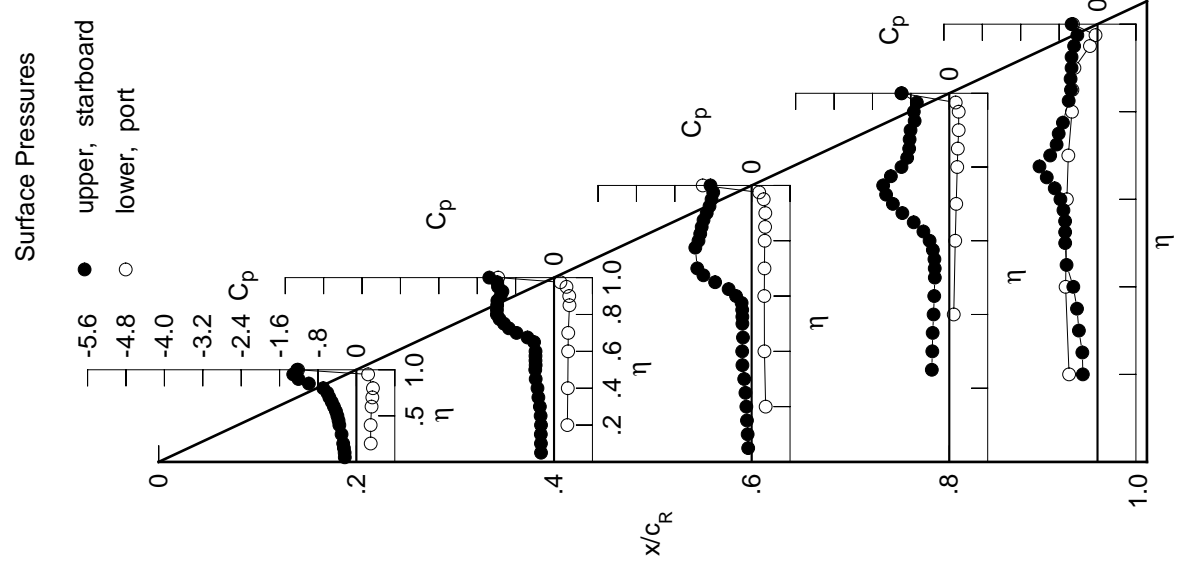
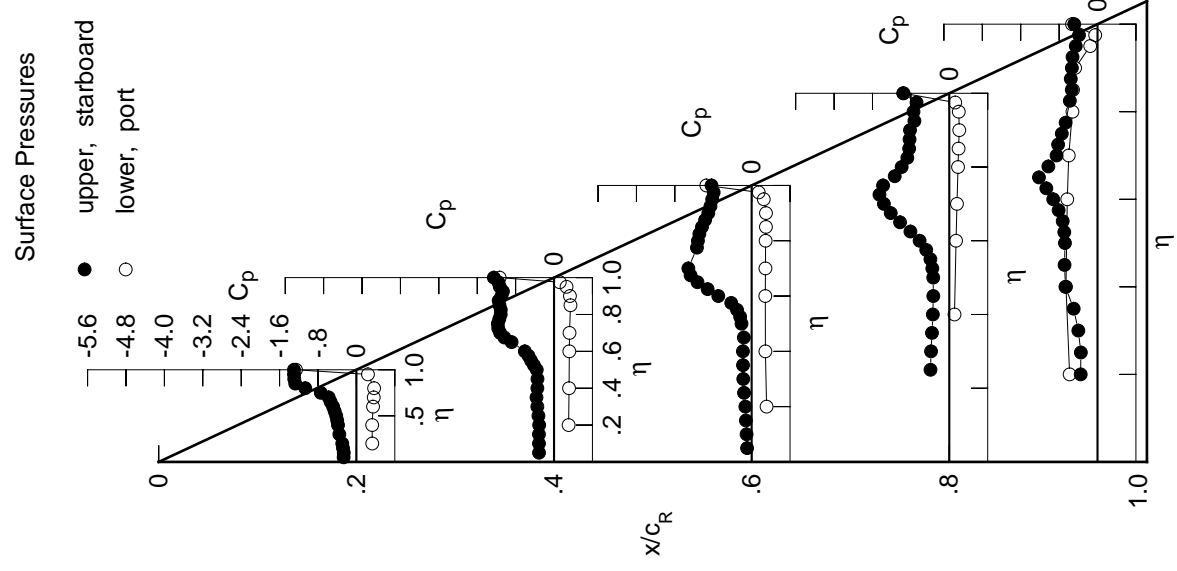
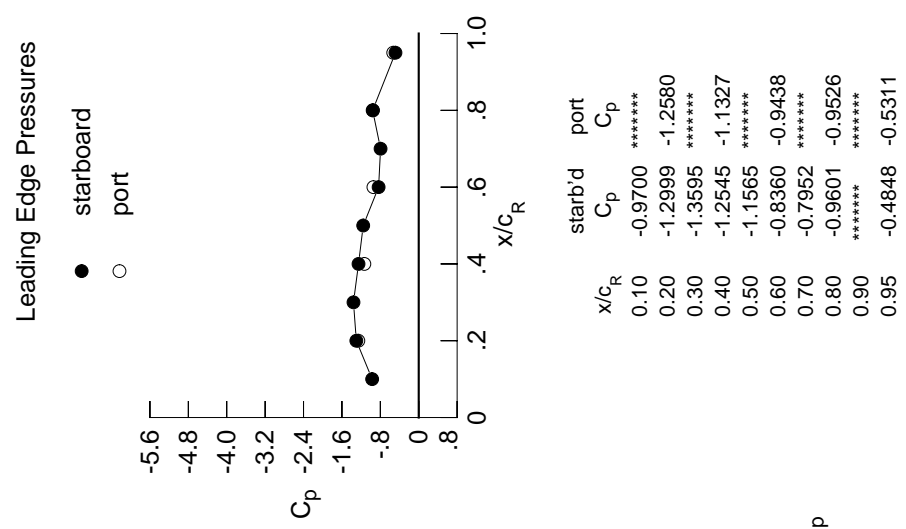

Table E7. Continued.

η	$x/c_R = .2$		$x/c_R = .4$		$x/c_R = .6$		$x/c_R = .8$		$x/c_R = .95$	
	$C_{p,u}$	$C_{p,u}$	$C_{p,u}$	$C_{p,u}$	$C_{p,u}$	$C_{p,u}$	$C_{p,u}$	$C_{p,u}$	$C_{p,u}$	$C_{p,u}$
0.050	-0.2656	-0.3125	-0.0944	*****	*****	*****	*****	*****	*****	*****
0.100	-0.2630	-0.3137	-0.1060	*****	*****	*****	*****	*****	*****	*****
0.150	-0.2791	-0.3145	-0.1199	*****	*****	*****	*****	*****	*****	*****
0.200	-0.2944	-0.3097	-0.1313	*****	*****	*****	*****	*****	*****	-0.3507
0.250	*****	-0.3249	-0.1581	-0.3913	-0.3913	-0.3913	-0.3913	-0.3913	-0.3913	-0.3476
0.300	-0.3553	-0.3478	-0.1746	-0.3799	-0.3799	-0.3799	-0.3799	-0.3799	-0.3799	-0.3991
0.350	*****	-0.3659	-0.1796	-0.3610	-0.3610	-0.3610	-0.3610	-0.3610	-0.3610	-0.4971
0.400	-0.3832	-0.3473	-0.1812	-0.3427	-0.3427	-0.3427	-0.3427	-0.3427	-0.3427	-0.6692
0.450	-0.3988	-0.3448	-0.1622	-0.3328	-0.3328	-0.3328	-0.3328	-0.3328	-0.3328	-0.6863
0.500	-0.4198	-0.3601	-0.2110	-0.3347	-0.3347	-0.3347	-0.3347	-0.3347	-0.3347	-0.6780
0.525	*****	-0.4198	-0.2391	-0.3538	-0.3538	-0.3538	-0.3538	-0.3538	-0.3538	-0.6916
0.550	-0.4528	-0.4796	-0.3038	-0.3939	-0.3939	-0.3939	-0.3939	-0.3939	-0.3939	-0.7251
0.575	*****	-0.5301	-0.4244	-0.4804	-0.4804	-0.4804	-0.4804	-0.4804	-0.4804	-0.8108
0.600	-0.4855	-0.6079	-0.6942	-0.6182	-0.6182	-0.6182	-0.6182	-0.6182	-0.6182	-0.9222
0.625	*****	*****	-0.9168	-0.8096	-0.8096	-0.8096	-0.8096	-0.8096	-0.8096	-1.0660
0.650	-0.5363	-0.8841	-1.1278	-1.0258	-1.0258	-1.0258	-1.0258	-1.0258	-1.0258	-1.2204
0.675	*****	-1.0343	-1.2723	-1.2204	-1.2204	-1.2204	-1.2204	-1.2204	-1.2204	-1.0242
0.700	-0.5771	-1.1222	-1.3181	-1.3625	-1.3625	-1.3625	-1.3625	-1.3625	-1.3625	-0.8529
0.725	*****	-1.1622	*****	-1.4551	-0.8210	-0.8210	-0.8210	-0.8210	-0.8210	-0.8210
0.750	-0.7414	-1.1715	*****	-1.3793	-0.7437	-0.7437	-0.7437	-0.7437	-0.7437	-0.7437
0.775	*****	-1.1412	-1.1388	-1.1365	-0.6642	-0.6642	-0.6642	-0.6642	-0.6642	-0.6642
0.800	-1.0655	-1.1111	-1.1191	-0.9930	*****	*****	*****	*****	*****	*****
0.825	*****	-1.1099	-1.0886	-0.8737	-0.5765	-0.5765	-0.5765	-0.5765	-0.5765	-0.5765
0.850	-1.2733	-1.1366	-1.0341	-0.8361	-0.5356	-0.5356	-0.5356	-0.5356	-0.5356	-0.5356
0.875	*****	-1.1539	-0.9693	-0.8276	-0.5566	-0.5566	-0.5566	-0.5566	-0.5566	-0.5566
0.900	-1.2944	-1.0936	-0.9024	-0.8182	-0.5340	-0.5340	-0.5340	-0.5340	-0.5340	-0.5340
0.925	*****	-1.0638	-0.8573	-0.7262	-0.5203	-0.5203	-0.5203	-0.5203	-0.5203	-0.5203
0.950	-1.2992	-1.1301	-0.8218	-0.7455	-0.4530	-0.4530	-0.4530	-0.4530	-0.4530	-0.4530
0.975	*****	-1.1588	-0.7911	-0.6825	-0.3855	-0.3855	-0.3855	-0.3855	-0.3855	-0.3855
1.000	-1.2999	-1.2545	-0.8360	-0.9601	-0.4848	-0.4848	-0.4848	-0.4848	-0.4848	-0.4848
	$C_{p,l}$	$C_{p,l}$	$C_{p,l}$	$C_{p,l}$	$C_{p,l}$	$C_{p,l}$	$C_{p,l}$	$C_{p,l}$	$C_{p,l}$	$C_{p,l}$
-0.200	0.3301	0.3040	0.3115	*****	-0.5812	-0.5812	-0.5812	-0.5812	-0.5812	-0.5812
-0.400	0.3286	0.3127	0.2868	0.1084	-0.6570	-0.6570	-0.6570	-0.6570	-0.6570	-0.6570
-0.600	0.3476	0.3188	0.2846	0.1409	-0.6301	-0.6301	-0.6301	-0.6301	-0.6301	-0.6301
-0.700	0.3614	0.3224	0.2875	0.1602	-0.5996	-0.5996	-0.5996	-0.5996	-0.5996	-0.5996
-0.800	0.3690	*****	0.2915	0.1825	-0.5222	-0.5222	-0.5222	-0.5222	-0.5222	-0.5222
-0.850	*****	0.3427	0.2979	0.1932	-0.5106	-0.5106	-0.5106	-0.5106	-0.5106	-0.5106
-0.900	*****	0.3312	0.2981	0.2082	-0.4661	-0.4661	-0.4661	-0.4661	-0.4661	-0.4661
-0.950	0.2410	0.2606	0.2524	0.1978	-0.1517	-0.1517	-0.1517	-0.1517	-0.1517	-0.1517
-0.975	*****	0.1191	0.1470	0.1230	-0.0482	-0.0482	-0.0482	-0.0482	-0.0482	-0.0482
-1.000	-1.2580	-1.1327	-0.9438	-0.9526	-0.5311	-0.5311	-0.5311	-0.5311	-0.5311	-0.5311

Medium Radius L.E.
 Run No. = 19, Point No. = 383
 $C_N = 0.703$, $C_m = -0.1178$
 $\alpha = 14.5^\circ$, $M_\infty = 0.849$
 $R_{mac} = 72.1 \times 10^6$



x/c_R	starb'd C_p	port C_p
0.10	-0.9700	*****
0.20	-1.2999	-1.2580
0.30	-1.3595	*****
0.40	-1.2545	-1.1327
0.50	-1.1565	*****
0.60	-0.8360	-0.9438
0.70	-0.7952	*****
0.80	-0.9601	-0.9526
0.90	*****	*****
0.95	-0.4848	-0.5311

Table E7. Continued.

η	$x/c_R = .2$		$x/c_R = .4$		$x/c_R = .6$		$x/c_R = .8$		$x/c_R = .95$	
	$C_{p,u}$	$C_{p,u}$	$C_{p,u}$	$C_{p,u}$	$C_{p,u}$	$C_{p,u}$	$C_{p,u}$	$C_{p,u}$	$C_{p,u}$	$C_{p,u}$
0.050	-0.3207	-0.3880	-0.1235	*****	*****	*****	*****	*****	*****	*****
0.100	-0.3137	-0.3868	-0.1347	*****	*****	*****	*****	*****	*****	*****
0.150	-0.3262	-0.3835	-0.1471	*****	*****	*****	*****	*****	*****	*****
0.200	-0.3421	-0.3809	-0.1644	*****	*****	*****	*****	*****	*****	*****
0.250	*****	-0.4026	-0.1903	-0.4544	-0.5200	*****	*****	*****	*****	*****
0.300	-0.4273	-0.4179	-0.2059	-0.4389	-0.5659	*****	*****	*****	*****	*****
0.350	*****	-0.4160	-0.2147	-0.4280	-0.5929	*****	*****	*****	*****	*****
0.400	-0.4428	-0.4085	-0.2266	-0.4177	-0.6650	*****	*****	*****	*****	*****
0.450	-0.4673	-0.4161	-0.2351	-0.4317	-0.7129	*****	*****	*****	*****	*****
0.500	-0.5055	-0.4516	-0.3655	-0.4925	-0.7686	*****	*****	*****	*****	*****
0.525	*****	-0.5311	-0.4806	-0.5621	-0.8205	*****	*****	*****	*****	*****
0.550	-0.5125	-0.6590	-0.6454	-0.6640	-0.8919	*****	*****	*****	*****	*****
0.575	*****	-0.8485	-0.8344	-0.8077	-0.9982	*****	*****	*****	*****	*****
0.600	-0.5301	-1.0424	-1.0737	-0.9686	-1.1080	*****	*****	*****	*****	*****
0.625	*****	*****	-1.2336	-1.1324	-0.7534	*****	*****	*****	*****	*****
0.650	-0.7267	-1.3437	-1.3653	-1.2838	-0.6577	*****	*****	*****	*****	*****
0.675	*****	-1.3966	-1.4681	-1.4079	-0.6270	*****	*****	*****	*****	*****
0.700	-1.0668	-1.3828	-1.5146	-1.2138	-0.5756	*****	*****	*****	*****	*****
0.725	*****	-1.4162	*****	-1.1275	-0.5186	*****	*****	*****	*****	*****
0.750	-1.1596	-1.4358	*****	-1.1150	-0.4703	*****	*****	*****	*****	*****
0.775	*****	-1.3515	-1.2026	-1.1483	-0.4521	*****	*****	*****	*****	*****
0.800	-1.3139	-1.2619	-1.1172	-1.2067	*****	*****	*****	*****	*****	*****
0.825	*****	-1.2120	-1.0468	-1.1968	-0.4889	*****	*****	*****	*****	*****
0.850	-1.3989	-1.1848	-1.0077	-1.1916	-0.4757	*****	*****	*****	*****	*****
0.875	*****	-1.1673	-1.0001	-1.0292	-0.5003	*****	*****	*****	*****	*****
0.900	-1.3523	-1.1290	-0.9995	-0.8768	-0.5198	*****	*****	*****	*****	*****
0.925	*****	-1.0945	-0.9259	-0.8064	-0.5117	*****	*****	*****	*****	*****
0.950	-1.2369	-1.0936	-0.8755	-0.8287	-0.4349	*****	*****	*****	*****	*****
0.975	*****	-1.0333	-0.8469	-0.7696	-0.3633	*****	*****	*****	*****	*****
1.000	-1.3961	-1.1574	-0.8367	-0.9580	-0.3744	*****	*****	*****	*****	*****
-0.200	$C_{p,l}$	$C_{p,l}$	$C_{p,l}$	$C_{p,l}$	$C_{p,l}$	$C_{p,l}$	$C_{p,l}$	$C_{p,l}$	$C_{p,l}$	$C_{p,l}$
-0.400	0.3886	0.3528	0.3471	*****	*****	*****	*****	*****	*****	*****
-0.600	0.3889	0.3604	0.3235	0.1397	-0.6336	*****	*****	*****	*****	*****
-0.700	0.4057	0.3663	0.3203	0.1700	-0.6100	*****	*****	*****	*****	*****
-0.800	0.4146	0.3677	0.3226	0.1883	-0.5769	*****	*****	*****	*****	*****
-0.850	0.4119	*****	0.3235	0.2092	-0.4979	*****	*****	*****	*****	*****
-0.900	*****	0.3756	0.3252	0.2176	-0.4825	*****	*****	*****	*****	*****
-0.950	*****	0.3509	0.3148	0.2264	-0.4345	*****	*****	*****	*****	*****
-0.975	0.2326	0.2548	0.2429	0.1946	-0.1403	*****	*****	*****	*****	*****
-1.000	*****	0.0858	0.1099	0.0943	-0.0605	*****	*****	*****	*****	*****
	-1.3201	-1.0838	-0.9130	-0.9187	-0.5016	*****	*****	*****	*****	*****

Medium Radius L.E.
 Run No. = 19, Point No. = 384
 $C_N = 0.811$, $C_m = -0.1275$
 $\alpha = 16.6^\circ$, $M_\infty = 0.852$
 $R_{mac} = 72.3 \times 10^6$

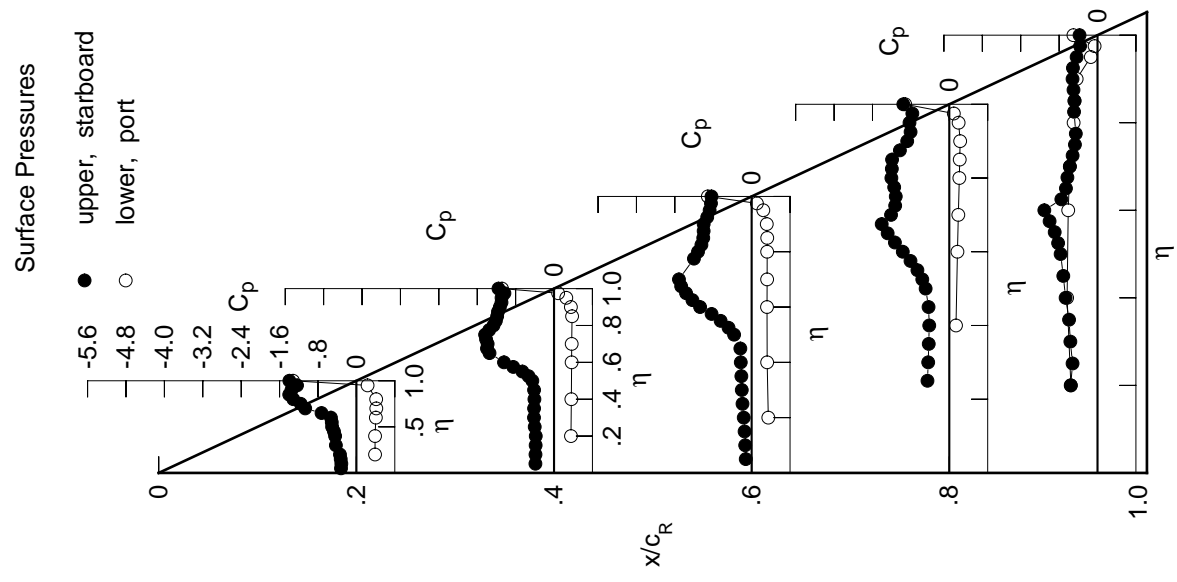
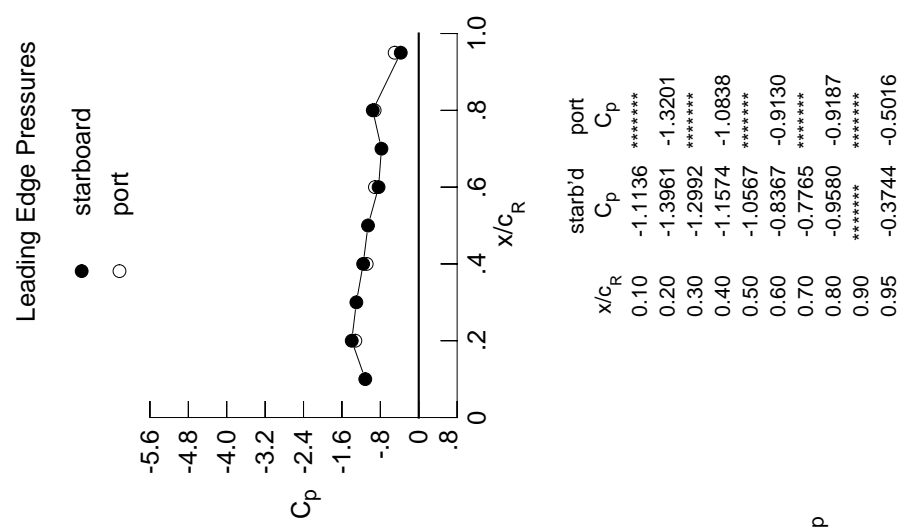

x/c_R	starb'd C_p	port C_p
0.10	-1.1136	*****
0.20	-1.3961	-1.3201
0.30	-1.2992	*****
0.40	-1.1574	-1.0838
0.50	-1.0567	*****
0.60	-0.8367	-0.9130
0.70	-0.7765	*****
0.80	-0.9580	-0.9187
0.90	*****	*****
0.95	-0.3744	-0.5016

Table E7. Continued.

η	$x/c_R = .2$		$x/c_R = .4$		$x/c_R = .6$		$x/c_R = .8$		$x/c_R = .95$	
	$C_{p,u}$	$C_{p,u}$	$C_{p,u}$	$C_{p,u}$	$C_{p,u}$	$C_{p,u}$	$C_{p,u}$	$C_{p,u}$	$C_{p,u}$	$C_{p,u}$
0.050	-0.3875	-0.4482	-0.0681	*****	*****	*****	*****	*****	*****	*****
0.100	-0.3808	-0.4488	-0.0800	*****	*****	*****	*****	*****	*****	*****
0.150	-0.3889	-0.4438	-0.0942	*****	*****	*****	*****	*****	*****	*****
0.200	-0.4384	-0.4669	-0.1211	*****	*****	*****	*****	*****	*****	-0.7146
0.250	*****	-0.4652	-0.1347	-0.2128	-0.1902	-0.16681	*****	*****	*****	-0.6903
0.300	-0.4312	-0.4679	-0.1489	-0.1902	-0.16681	*****	*****	*****	*****	-0.6681
0.350	-0.4757	-0.1756	-0.1860	-0.6814	*****	*****	*****	*****	*****	-0.6814
0.400	-0.4501	-0.4842	-0.2193	-0.1653	-0.7153	*****	*****	*****	*****	-0.7153
0.450	-0.4600	-0.5326	-0.2826	-0.1995	-0.7356	*****	*****	*****	*****	-0.7356
0.500	-0.4818	-0.6532	-0.5174	-0.2956	-0.7143	*****	*****	*****	*****	-0.7143
0.525	*****	-0.7908	-0.6821	-0.3787	-0.7320	*****	*****	*****	*****	-0.7320
0.550	-0.6800	-0.9805	-0.8617	-0.4844	-0.7021	*****	*****	*****	*****	-0.7021
0.575	-1.1725	-1.0391	-0.6149	-0.7149	*****	*****	*****	*****	*****	-0.7149
0.600	-1.1647	-1.3415	-1.2321	-0.7409	-0.7050	*****	*****	*****	*****	-0.7050
0.625	*****	*****	-1.3430	-0.7971	-0.7058	*****	*****	*****	*****	-0.7058
0.650	-1.3635	-1.5709	-1.4481	-0.6700	-0.7052	*****	*****	*****	*****	-0.7052
0.675	*****	-1.6260	-1.4837	-0.6145	-0.6820	*****	*****	*****	*****	-0.6820
0.700	-1.3187	-1.6316	-1.2844	-0.5802	-0.6671	*****	*****	*****	*****	-0.6671
0.725	*****	-1.5006	*****	-0.5478	-0.6578	*****	*****	*****	*****	-0.6578
0.750	-1.3175	-1.4598	*****	-0.5229	-0.6419	*****	*****	*****	*****	-0.6419
0.775	*****	-1.4322	-1.1871	-0.5264	-0.6310	*****	*****	*****	*****	-0.6310
0.800	-1.4109	-1.3027	-1.1902	-0.5426	*****	*****	*****	*****	*****	-0.5426
0.825	*****	-1.2326	-1.2046	-0.5439	-0.5997	*****	*****	*****	*****	-0.5997
0.850	-1.4086	-1.1861	-1.1512	-0.5664	-0.5624	*****	*****	*****	*****	-0.5624
0.875	*****	-1.1708	-1.0493	-0.5623	-0.5455	*****	*****	*****	*****	-0.5455
0.900	-1.3013	-1.1414	-0.9335	-0.5649	-0.5259	*****	*****	*****	*****	-0.5259
0.925	*****	-1.1061	-0.8667	-0.5722	-0.5155	*****	*****	*****	*****	-0.5155
0.950	-1.2215	-1.0872	-0.8343	-0.5860	-0.4641	*****	*****	*****	*****	-0.4641
0.975	*****	-1.0353	-0.8165	-0.5676	-0.4348	*****	*****	*****	*****	-0.4348
1.000	-1.4431	-1.1283	-0.7907	-0.6729	-0.5133	*****	*****	*****	*****	-0.5133
-0.200	$C_{p,l}$	$C_{p,l}$	$C_{p,l}$	$C_{p,l}$	$C_{p,l}$	$C_{p,l}$	$C_{p,l}$	$C_{p,l}$	$C_{p,l}$	$C_{p,l}$
-0.400	0.4438	0.3973	0.3791	*****	-0.5803	*****	*****	*****	*****	-0.5803
-0.600	0.4433	0.4046	0.3563	0.1588	-0.6470	*****	*****	*****	*****	-0.6470
-0.700	0.4573	0.4090	0.3538	0.1901	-0.6157	*****	*****	*****	*****	-0.6157
-0.800	0.4608	0.4086	0.3564	0.2103	-0.5824	*****	*****	*****	*****	-0.5824
-0.850	0.4482	*****	0.3537	0.2313	-0.5048	*****	*****	*****	*****	-0.5048
-0.900	*****	0.4033	0.3524	0.2389	-0.4915	*****	*****	*****	*****	-0.4915
-0.950	*****	0.3666	0.3333	0.2460	-0.4460	*****	*****	*****	*****	-0.4460
-0.975	0.2223	0.2475	0.2412	0.2083	-0.1634	*****	*****	*****	*****	-0.1634
-1.000	*****	0.0546	0.0885	0.1064	-0.0981	*****	*****	*****	*****	-0.0981
-1.000	-1.3736	-1.0798	-0.8748	-0.7154	-0.5779	*****	*****	*****	*****	-0.5779

Medium Radius L.E.
 Run No. = 19, Point No. = 385
 $C_N = 0.810$, $C_m = -0.1047$
 $\alpha = 18.6^\circ$, $M_\infty = 0.852$
 $R_{mac} = 72.2 \times 10^6$

Leading Edge Pressures

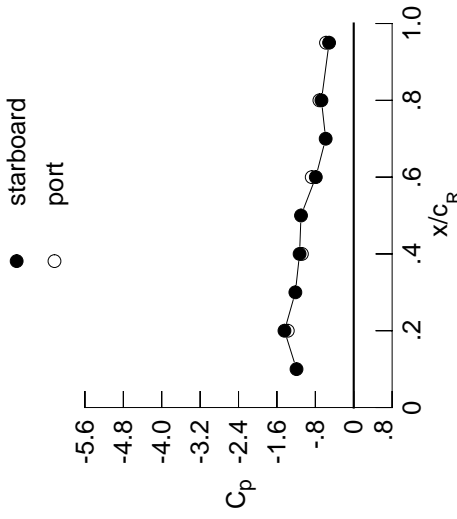

x/c_R	starb'd C_p	port C_p
0.10	-1.1923	*****
0.20	-1.4431	-1.3736
0.30	-1.2158	*****
0.40	-1.1283	-1.0798
0.50	-1.0986	*****
0.60	-0.7907	-0.8748
0.70	-0.5848	*****
0.80	-0.6729	-0.7154
0.90	*****	*****
0.95	-0.5133	-0.5779

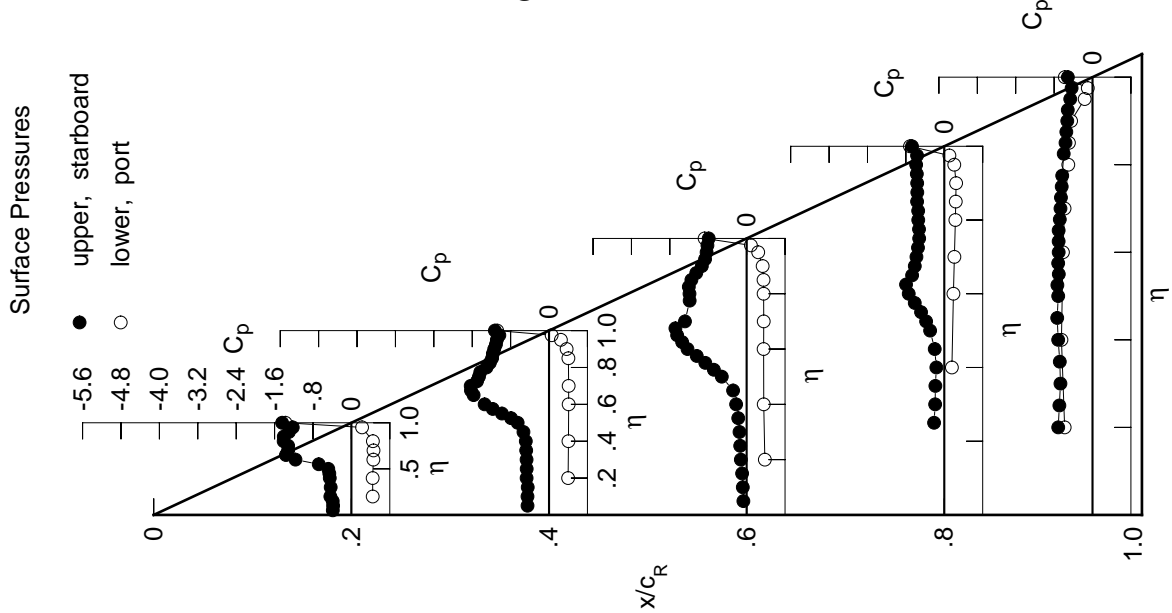
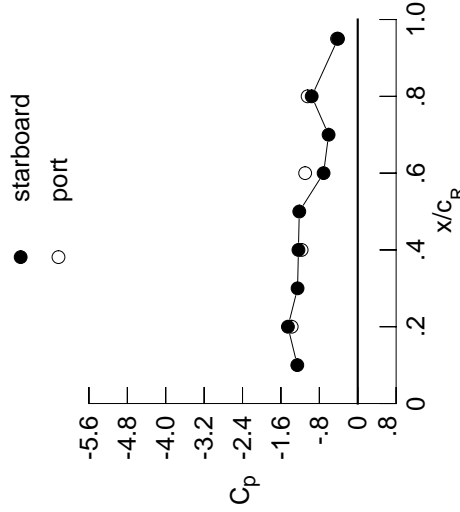

Table E7. Continued.

η	$x/c_R = .2$		$x/c_R = .4$		$x/c_R = .6$		$x/c_R = .8$		$x/c_R = .95$	
	$C_{p,u}$	$C_{p,u}$	$C_{p,u}$	$C_{p,u}$	$C_{p,u}$	$C_{p,u}$	$C_{p,u}$	$C_{p,u}$	$C_{p,u}$	$C_{p,u}$
0.050	-0.4532	-0.5238	-0.0775	*****	*****	*****	*****	*****	*****	*****
0.100	-0.4462	-0.5220	-0.0827	*****	*****	*****	*****	*****	*****	*****
0.150	-0.4834	-0.5210	-0.0927	*****	*****	*****	*****	*****	*****	*****
0.200	-0.4888	-0.5412	-0.1053	*****	*****	*****	*****	*****	*****	-0.5390
0.250	*****	-0.5465	-0.1398	-0.5224	-0.5352	*****	*****	*****	*****	*****
0.300	-0.4823	-0.5550	-0.1515	-0.5421	-0.5696	*****	*****	*****	*****	*****
0.350	*****	-0.5825	-0.2011	-0.6103	-0.6360	*****	*****	*****	*****	*****
0.400	-0.5045	-0.6401	-0.2983	-0.6723	-0.7160	*****	*****	*****	*****	*****
0.450	-0.5307	-0.7930	-0.4471	-0.7838	-0.7576	*****	*****	*****	*****	*****
0.500	-0.6600	-1.0210	-0.7609	-0.8786	-0.7295	*****	*****	*****	*****	*****
0.525	*****	-1.1624	-0.9302	-0.9058	-0.7397	*****	*****	*****	*****	*****
0.550	-1.1097	-1.3184	-1.0838	-0.9168	-0.7101	*****	*****	*****	*****	*****
0.575	*****	-1.4337	-1.2258	-0.9253	-0.7192	*****	*****	*****	*****	*****
0.600	-1.5397	-1.5278	-1.3700	-0.9312	-0.7088	*****	*****	*****	*****	*****
0.625	*****	*****	-1.4470	-0.9279	-0.7067	*****	*****	*****	*****	*****
0.650	-1.7139	-1.6693	-1.2630	-0.9054	-0.7028	*****	*****	*****	*****	*****
0.675	*****	-1.6932	-1.1443	-0.8700	-0.6894	*****	*****	*****	*****	*****
0.700	-1.5302	-1.5368	-1.1101	-0.8302	-0.6832	*****	*****	*****	*****	*****
0.725	*****	-1.5118	*****	-0.7982	-0.6784	*****	*****	*****	*****	*****
0.750	-1.4257	-1.4854	*****	-0.7613	-0.6621	*****	*****	*****	*****	*****
0.775	*****	-1.4706	-1.0858	-0.7518	-0.6495	*****	*****	*****	*****	*****
0.800	-1.4943	-1.4139	-1.1568	-0.7506	*****	*****	*****	*****	*****	*****
0.825	*****	-1.3594	-1.2068	-0.7394	-0.6111	*****	*****	*****	*****	*****
0.850	-1.4391	-1.3040	-1.0737	-0.7679	-0.5773	*****	*****	*****	*****	*****
0.875	*****	-1.2315	-0.9081	-0.7890	-0.5503	*****	*****	*****	*****	*****
0.900	-1.3024	-1.1870	-0.8267	-0.8324	-0.5137	*****	*****	*****	*****	*****
0.925	*****	-1.1765	-0.8283	-0.8855	-0.4821	*****	*****	*****	*****	*****
0.950	-1.2381	-1.1816	-0.8189	-0.9192	-0.4381	*****	*****	*****	*****	*****
0.975	*****	-1.1537	-0.7829	-0.8757	-0.4011	*****	*****	*****	*****	*****
1.000	-1.4546	-1.2356	-0.7110	-0.9589	-0.4108	*****	*****	*****	*****	*****
-0.200	$C_{p,l}$	$C_{p,l}$	$C_{p,l}$	$C_{p,l}$	$C_{p,l}$	$C_{p,l}$	$C_{p,l}$	$C_{p,l}$	$C_{p,l}$	$C_{p,l}$
-0.400	0.5031	0.4463	0.4175	*****	*****	*****	*****	*****	*****	*****
-0.600	0.5024	0.4528	0.3943	0.1958	-0.6101	*****	*****	*****	*****	*****
-0.700	0.5124	0.4542	0.3884	0.2228	-0.5806	*****	*****	*****	*****	*****
-0.800	0.5092	0.4512	0.3890	0.2390	-0.5428	*****	*****	*****	*****	*****
-0.850	0.4839	*****	0.3804	0.2556	-0.4591	*****	*****	*****	*****	*****
-0.900	*****	0.4289	0.3716	0.2575	-0.4391	*****	*****	*****	*****	*****
-0.950	0.2081	0.2308	0.2136	0.1757	-0.1240	*****	*****	*****	*****	*****
-0.975	*****	0.0109	0.0291	0.0256	-0.0824	*****	*****	*****	*****	*****
-1.000	-1.3756	-1.1691	-1.0955	-1.0442	-0.4315	*****	*****	*****	*****	*****

Medium Radius L.E.
 Run No. = 19, Point No. = 386
 $C_N = 0.977$, $C_m = -0.1501$
 $\alpha = 20.7^\circ$, $M_\infty = 0.849$
 $R_{mac} = 72.1 \times 10^6$

Leading Edge Pressures



x/c_R	starb'd C_p	port C_p
0.10	-1.2594	*****
0.20	-1.4546	-1.3756
0.30	-1.2533	*****
0.40	-1.2356	-1.1691
0.50	-1.2177	*****
0.60	-0.7110	-1.0955
0.70	-0.6070	*****
0.80	-0.9589	-1.0442
0.90	*****	*****
0.95	-0.4108	-0.4315

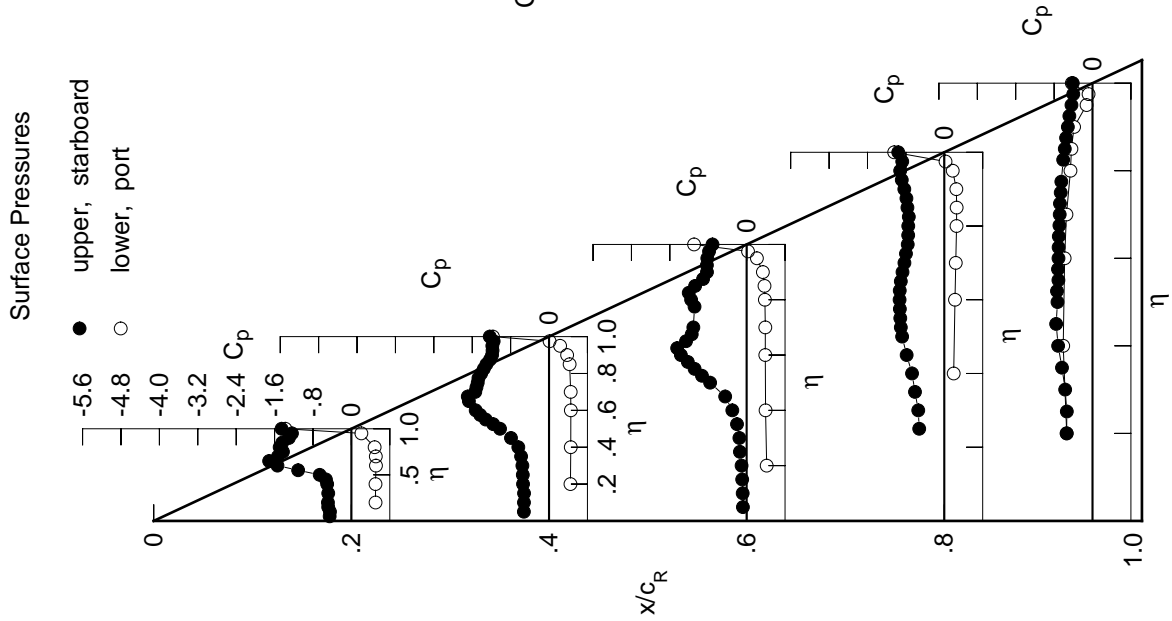
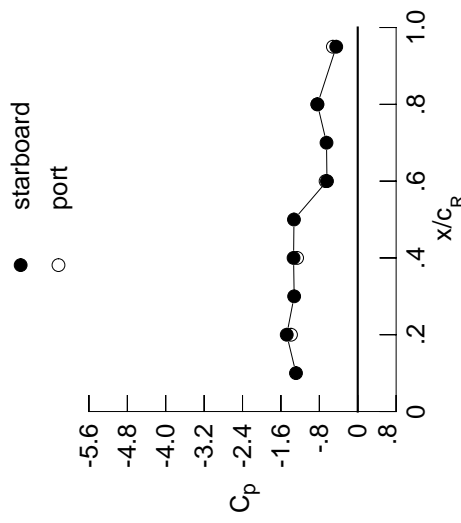

Table E7. Concluded.

η	$x/c_R = .2$		$x/c_R = .4$		$x/c_R = .6$		$x/c_R = .8$		$x/c_R = .95$	
	$C_{p,u}$	$C_{p,u}$	$C_{p,u}$	$C_{p,u}$	$C_{p,u}$	$C_{p,u}$	$C_{p,u}$	$C_{p,u}$	$C_{p,u}$	$C_{p,u}$
0.050	-0.5266	-0.6046	-0.0137	*****	*****	*****	*****	*****	*****	*****
0.100	-0.5295	-0.6071	-0.0274	*****	*****	*****	*****	*****	*****	*****
0.150	-0.5615	-0.6037	-0.0422	*****	*****	*****	*****	*****	*****	*****
0.200	-0.5618	-0.6200	-0.0637	*****	*****	*****	*****	*****	*****	-0.5467
0.250	*****	-0.6422	-0.0991	-0.5896	-0.5896	-0.5896	-0.5896	-0.5896	-0.5896	-0.5614
0.300	-0.5593	-0.6623	-0.1529	-0.6157	-0.6157	-0.6157	-0.6157	-0.6157	-0.6157	-0.6016
0.350	*****	-0.7223	-0.2491	-0.6923	-0.6923	-0.6923	-0.6923	-0.6923	-0.6923	-0.6465
0.400	-0.6099	-0.8283	-0.4081	-0.7646	-0.7646	-0.7646	-0.7646	-0.7646	-0.7646	-0.7261
0.450	-0.7350	-1.0131	-0.6122	-0.8702	-0.8702	-0.8702	-0.8702	-0.8702	-0.8702	-0.8035
0.500	-1.0550	-1.2117	-0.9264	-0.9465	-0.9465	-0.9465	-0.9465	-0.9465	-0.9465	-0.8089
0.525	*****	-1.3261	-1.0706	-0.9653	-0.9653	-0.9653	-0.9653	-0.9653	-0.9653	-0.8273
0.550	-1.4500	-1.4597	-1.2009	-0.9660	-0.9660	-0.9660	-0.9660	-0.9660	-0.9660	-0.7924
0.575	*****	-1.5455	-1.3147	-0.9629	-0.9629	-0.9629	-0.9629	-0.9629	-0.9629	-0.7944
0.600	-1.6957	-1.6230	-1.4323	-0.9553	-0.9553	-0.9553	-0.9553	-0.9553	-0.9553	-0.7758
0.625	*****	*****	-1.4282	-0.9395	-0.9395	-0.9395	-0.9395	-0.9395	-0.9395	-0.7681
0.650	-1.8041	-1.5177	-1.2102	-0.9317	-0.9317	-0.9317	-0.9317	-0.9317	-0.9317	-0.7614
0.675	*****	-1.4791	-1.1308	-0.9002	-0.9002	-0.9002	-0.9002	-0.9002	-0.9002	-0.7419
0.700	-1.6725	-1.4353	-1.0969	-0.8588	-0.8588	-0.8588	-0.8588	-0.8588	-0.8588	-0.7332
0.725	*****	-1.4294	*****	-0.8345	-0.8345	-0.8345	-0.8345	-0.8345	-0.8345	-0.7209
0.750	-1.5326	-1.4176	*****	-0.8011	-0.8011	-0.8011	-0.8011	-0.8011	-0.8011	-0.7005
0.775	*****	-1.4289	-1.0059	-0.7991	-0.7991	-0.7991	-0.7991	-0.7991	-0.7991	-0.6834
0.800	-1.4238	-1.4620	-1.0305	-0.8025	-0.8025	-0.8025	-0.8025	-0.8025	-0.8025	*****
0.825	*****	-1.4174	-1.0516	-0.7888	-0.7888	-0.7888	-0.7888	-0.7888	-0.7888	-0.6469
0.850	-1.4026	-1.3384	-0.9624	-0.8111	-0.8111	-0.8111	-0.8111	-0.8111	-0.8111	-0.6089
0.875	*****	-1.3029	-0.8747	-0.8159	-0.8159	-0.8159	-0.8159	-0.8159	-0.8159	-0.5844
0.900	-1.3311	-1.3018	-0.8023	-0.8194	-0.8194	-0.8194	-0.8194	-0.8194	-0.8194	-0.5552
0.925	*****	-1.2934	-0.7653	-0.8147	-0.8147	-0.8147	-0.8147	-0.8147	-0.8147	-0.5351
0.950	-1.2749	-1.3099	-0.7346	-0.8277	-0.8277	-0.8277	-0.8277	-0.8277	-0.8277	-0.4878
0.975	*****	-1.2856	-0.7006	-0.8134	-0.8134	-0.8134	-0.8134	-0.8134	-0.8134	-0.4513
1.000	-1.4790	-1.3364	-0.6412	-0.8391	-0.8391	-0.8391	-0.8391	-0.8391	-0.8391	-0.4476
	$C_{p,l}$	$C_{p,l}$	$C_{p,l}$	$C_{p,l}$	$C_{p,l}$	$C_{p,l}$	$C_{p,l}$	$C_{p,l}$	$C_{p,l}$	$C_{p,l}$
-0.200	0.5589	0.4935	0.4557	*****	*****	*****	*****	*****	*****	-0.5288
-0.400	0.5596	0.4990	0.4324	0.2220	0.2220	0.2220	0.2220	0.2220	0.2220	-0.5972
-0.600	0.5650	0.4985	0.4277	0.2516	0.2516	0.2516	0.2516	0.2516	0.2516	-0.5707
-0.700	0.5552	0.4958	0.4293	0.2650	0.2650	0.2650	0.2650	0.2650	0.2650	-0.5329
-0.800	0.5176	*****	0.4202	0.2812	0.2812	0.2812	0.2812	0.2812	0.2812	-0.4528
-0.850	*****	0.4569	0.4087	0.2828	0.2828	0.2828	0.2828	0.2828	0.2828	-0.4330
-0.900	*****	0.3911	0.3679	0.2724	0.2724	0.2724	0.2724	0.2724	0.2724	-0.3836
-0.950	0.1967	0.2223	0.2315	0.1885	0.1885	0.1885	0.1885	0.1885	0.1885	-0.1411
-0.975	*****	-0.0190	0.0398	0.0329	0.0329	0.0329	0.0329	0.0329	0.0329	-0.1199
-1.000	-1.3905	-1.2635	-0.6698	-0.8420	-0.8420	-0.8420	-0.8420	-0.8420	-0.8420	-0.5174

Medium Radius L.E.
 Run No. = 19, Point No. = 387
 $C_N = 1.024$, $C_m = -0.1523$
 $\alpha = 22.7^\circ$, $M_\infty = 0.851$
 $R_{mac} = 72.0 \times 10^6$

Leading Edge Pressures



x/c_R	starb'd C_p	port C_p
0.10	-1.2866	*****
0.20	-1.4790	-1.3905
0.30	-1.3245	*****
0.40	-1.3364	-1.2635
0.50	-1.3284	*****
0.60	-0.6412	-0.6698
0.70	-0.6503	*****
0.80	-0.8391	-0.8420
0.90	*****	*****
0.95	-0.4476	-0.5174

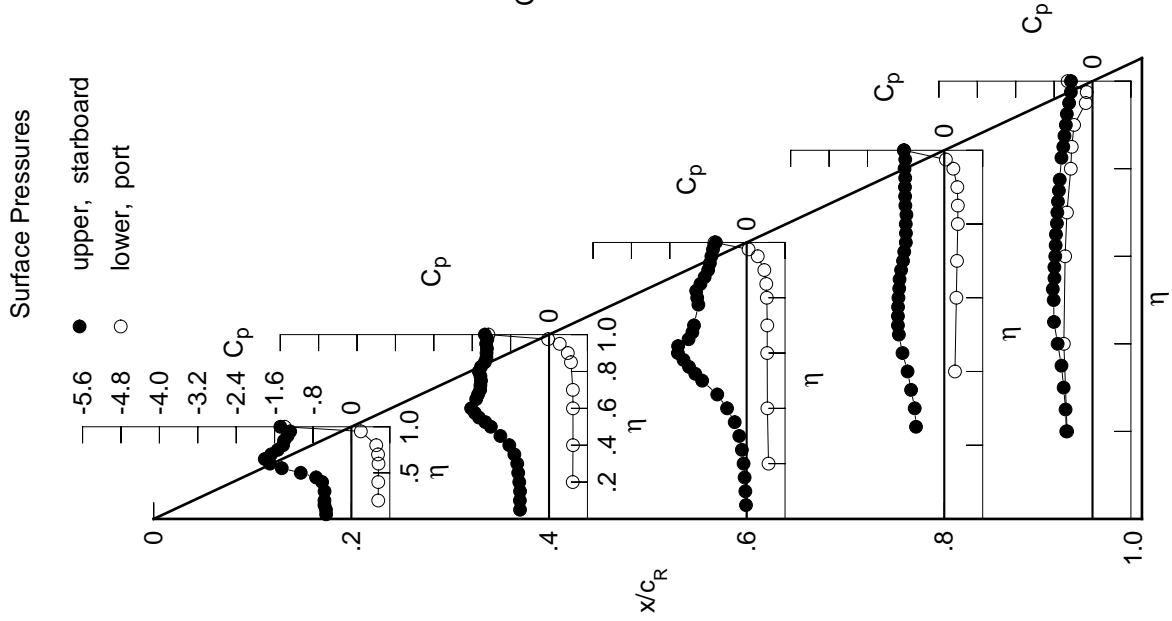
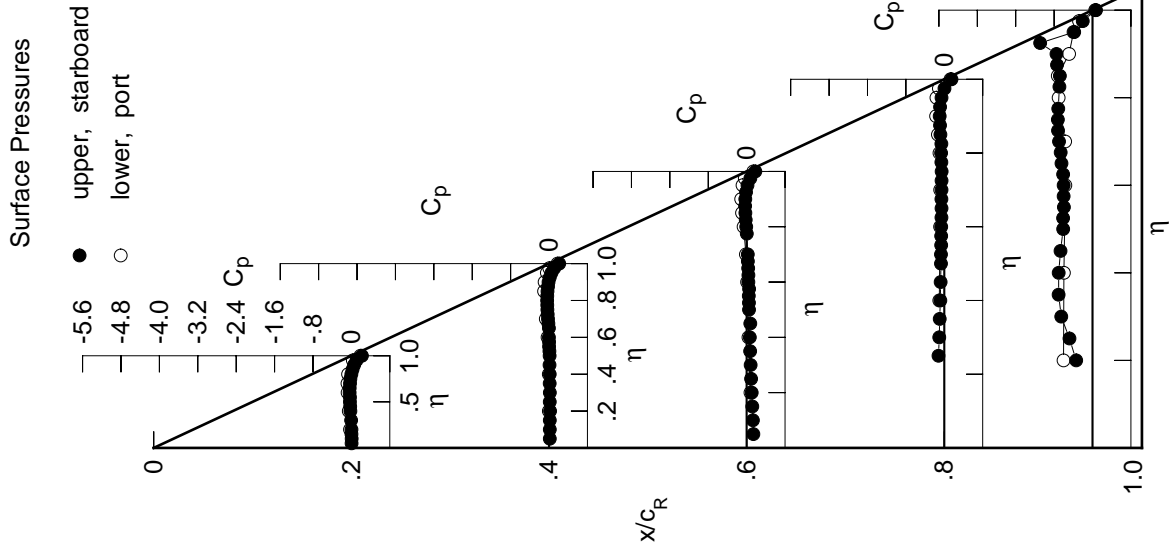

Table E8. Tabulations and Plots of Surface Pressure Coefficients.

η	$x/c_R = .2$		$x/c_R = .4$		$x/c_R = .6$		$x/c_R = .8$		$x/c_R = .95$	
	$C_{p,u}$	$C_{p,u}$	$C_{p,u}$	$C_{p,u}$	$C_{p,u}$	$C_{p,u}$	$C_{p,u}$	$C_{p,u}$	$C_{p,u}$	$C_{p,u}$
0.050	0.0036	0.0158	0.1397	*****	*****	*****	*****	*****	*****	
0.100	0.0059	0.0159	0.1303	*****	*****	*****	*****	*****	*****	
0.150	0.0015	0.0162	0.1176	*****	*****	*****	*****	*****	*****	
0.200	0.0019	0.0214	0.1060	*****	*****	*****	*****	*****	*****	
0.250	*****	0.0152	0.0927	-0.1205	-0.4801	-0.3398	-0.4801	-0.3398	-0.4801	
0.300	-0.0059	0.0168	0.0833	-0.1051	-0.6510	-0.6510	-0.6510	-0.6510	-0.6510	
0.350	*****	0.0134	0.0726	-0.0954	-0.7062	-0.7062	-0.7062	-0.7062	-0.7062	
0.400	-0.0205	0.0143	0.0663	-0.0824	-0.7046	-0.7046	-0.7046	-0.7046	-0.7046	
0.450	-0.0251	0.0104	0.0757	-0.0759	-0.6660	-0.6660	-0.6660	-0.6660	-0.6660	
0.500	-0.0303	0.0118	0.0492	-0.0691	-0.6109	-0.6109	-0.6109	-0.6109	-0.6109	
0.525	*****	0.0077	0.0478	-0.0688	-0.6125	-0.6125	-0.6125	-0.6125	-0.6125	
0.550	-0.0299	0.0010	0.0448	-0.0647	-0.5963	-0.5963	-0.5963	-0.5963	-0.5963	
0.575	*****	0.0006	0.0508	-0.0646	-0.6012	-0.6012	-0.6012	-0.6012	-0.6012	
0.600	-0.0370	-0.0021	0.0360	-0.0641	-0.6016	-0.6016	-0.6016	-0.6016	-0.6016	
0.625	*****	*****	0.0368	-0.0590	-0.6123	-0.6123	-0.6123	-0.6123	-0.6123	
0.650	-0.0353	-0.0027	0.0322	-0.0574	-0.6463	-0.6463	-0.6463	-0.6463	-0.6463	
0.675	*****	-0.0138	0.0254	-0.0598	-0.6636	-0.6636	-0.6636	-0.6636	-0.6636	
0.700	-0.0291	-0.0214	0.0239	-0.0576	-0.6975	-0.6975	-0.6975	-0.6975	-0.6975	
0.725	*****	-0.0279	*****	-0.0565	-0.7184	-0.7184	-0.7184	-0.7184	-0.7184	
0.750	-0.0208	-0.0341	*****	-0.0554	-0.7216	-0.7216	-0.7216	-0.7216	-0.7216	
0.775	*****	-0.0369	0.0033	-0.0612	-0.7135	-0.7135	-0.7135	-0.7135	-0.7135	
0.800	-0.0007	-0.0395	-0.0085	-0.0663	*****	*****	*****	*****	*****	
0.825	*****	-0.0369	-0.0192	-0.0609	-0.6899	-0.6899	-0.6899	-0.6899	-0.6899	
0.850	0.0233	-0.0316	-0.0261	-0.0810	-0.6797	-0.6797	-0.6797	-0.6797	-0.6797	
0.875	*****	-0.0216	-0.0316	-0.0891	-0.7392	-0.7392	-0.7392	-0.7392	-0.7392	
0.900	0.0565	-0.0104	-0.0277	-0.0960	-0.7507	-0.7507	-0.7507	-0.7507	-0.7507	
0.925	*****	0.0149	-0.0132	-0.0883	-1.0904	-1.0904	-1.0904	-1.0904	-1.0904	
0.950	0.1064	0.0513	0.0173	-0.0578	-0.3812	-0.3812	-0.3812	-0.3812	-0.3812	
0.975	*****	0.1080	0.0768	0.0040	-0.2035	-0.2035	-0.2035	-0.2035	-0.2035	
1.000	0.2190	0.2123	0.1809	0.1499	0.0728	0.0728	0.0728	0.0728	0.0728	
η	$C_{p,l}$	$C_{p,l}$	$C_{p,l}$	$C_{p,l}$	$C_{p,l}$	$C_{p,l}$	$C_{p,l}$	$C_{p,l}$	$C_{p,l}$	
-0.200	-0.0287	-0.0036	0.0796	*****	-0.6035	-0.6035	-0.6035	-0.6035	-0.6035	
-0.400	-0.0547	-0.0050	0.0386	-0.1043	-0.5961	-0.5961	-0.5961	-0.5961	-0.5961	
-0.600	-0.0786	-0.0306	0.0099	-0.0871	-0.5667	-0.5667	-0.5667	-0.5667	-0.5667	
-0.700	-0.0816	-0.0673	-0.0148	-0.0859	-0.5706	-0.5706	-0.5706	-0.5706	-0.5706	
-0.800	-0.0692	*****	-0.0632	-0.0999	-0.7053	-0.7053	-0.7053	-0.7053	-0.7053	
-0.850	*****	-0.1029	-0.0957	-0.1327	-0.7231	-0.7231	-0.7231	-0.7231	-0.7231	
-0.900	*****	-0.0922	-0.1140	-0.1702	-0.4882	-0.4882	-0.4882	-0.4882	-0.4882	
-0.950	0.0302	-0.0446	-0.0857	-0.1632	-0.3951	-0.3951	-0.3951	-0.3951	-0.3951	
-0.975	*****	0.0063	-0.0383	-0.1120	-0.2806	-0.2806	-0.2806	-0.2806	-0.2806	
-1.000	0.1888	0.1771	0.1397	0.1298	0.0568	0.0568	0.0568	0.0568	0.0568	

Medium Radius L.E.
 Run No. = 20 , Point No. = 388
 $C_N = -0.031$, $C_m = 0.0042$
 $\alpha = -0.7^\circ$, $M_\infty = 0.851$
 $R_{mac} = 83.7 \times 10^6$



Leading Edge Pressures

● starboard
 ○ port

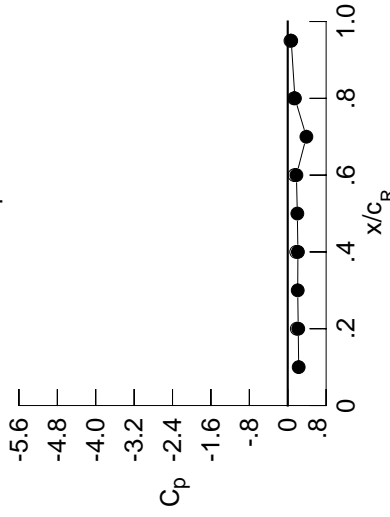

x/c_R	starb'd C_p	port C_p
0.10	0.2282	*****
0.20	0.2190	0.1888
0.30	0.2079	*****
0.40	0.2123	0.1771
0.50	0.1997	*****
0.60	0.1809	0.1397
0.70	0.3886	*****
0.80	0.1499	0.1298
0.90	*****	*****
0.95	0.0728	0.0568

Table E8. Continued.

η	$x/c_R = .2$		$x/c_R = .4$		$x/c_R = .6$		$x/c_R = .8$		$x/c_R = .95$	
	$C_{p,u}$	$C_{p,u}$	$C_{p,u}$	$C_{p,u}$	$C_{p,u}$	$C_{p,u}$	$C_{p,u}$	$C_{p,u}$	$C_{p,u}$	$C_{p,u}$
0.050	-0.0034	0.0096	0.1359	*****	*****	*****	*****	*****	*****	
0.100	-0.0010	0.0098	0.1266	*****	*****	*****	*****	*****	*****	
0.150	-0.0062	0.0096	0.1139	*****	*****	*****	*****	*****	*****	
0.200	-0.0054	0.0144	0.1012	*****	*****	*****	*****	*****	*****	
0.250	*****	0.0085	0.0884	-0.1248	-0.4755	*****	*****	*****	*****	
0.300	-0.0134	0.0102	0.0786	-0.1086	-0.6327	*****	*****	*****	*****	
0.350	*****	0.0065	0.0677	-0.0996	-0.6799	*****	*****	*****	*****	
0.400	-0.0287	0.0074	0.0616	-0.0862	-0.6693	*****	*****	*****	*****	
0.450	-0.0344	0.0028	0.0706	-0.0804	-0.6234	*****	*****	*****	*****	
0.500	-0.0398	0.0042	0.0443	-0.0742	-0.5702	*****	*****	*****	*****	
0.525	*****	0.0002	0.0418	-0.0742	-0.5774	*****	*****	*****	*****	
0.550	-0.0398	-0.0073	0.0394	-0.0693	-0.5606	*****	*****	*****	*****	
0.575	*****	-0.0075	0.0444	-0.0695	-0.5662	*****	*****	*****	*****	
0.600	-0.0476	-0.0111	0.0298	-0.0690	-0.5660	*****	*****	*****	*****	
0.625	*****	*****	0.0301	-0.0641	-0.5788	*****	*****	*****	*****	
0.650	-0.0469	-0.0113	0.0257	-0.0632	-0.6164	*****	*****	*****	*****	
0.675	*****	-0.0234	0.0183	-0.0657	-0.6385	*****	*****	*****	*****	
0.700	-0.0415	-0.0310	0.0159	-0.0641	-0.6801	*****	*****	*****	*****	
0.725	*****	-0.0393	*****	-0.0635	-0.7099	*****	*****	*****	*****	
0.750	-0.0342	-0.0457	*****	-0.0631	-0.7190	*****	*****	*****	*****	
0.775	*****	-0.0492	-0.0060	-0.0695	-0.7136	*****	*****	*****	*****	
0.800	-0.0146	-0.0530	-0.0196	-0.0755	*****	*****	*****	*****	*****	
0.825	*****	-0.0517	-0.0309	-0.0701	-0.6890	*****	*****	*****	*****	
0.850	0.0084	-0.0478	-0.0400	-0.0922	-0.6806	*****	*****	*****	*****	
0.875	*****	-0.0384	-0.0467	-0.1021	-0.7467	*****	*****	*****	*****	
0.900	0.0411	-0.0283	-0.0453	-0.1125	-0.7303	*****	*****	*****	*****	
0.925	*****	-0.0041	-0.0323	-0.1065	-1.0299	*****	*****	*****	*****	
0.950	0.0906	0.0318	-0.0037	-0.0789	-0.3920	*****	*****	*****	*****	
0.975	*****	0.0882	0.0546	-0.0199	-0.2211	*****	*****	*****	*****	
1.000	0.2241	0.2211	0.2006	0.1648	0.0830	*****	*****	*****	*****	
η	$C_{p,l}$	$C_{p,l}$	$C_{p,l}$	$C_{p,l}$	$C_{p,l}$	$C_{p,l}$	$C_{p,l}$	$C_{p,l}$	$C_{p,l}$	
-0.200	-0.0211	0.0033	0.0851	*****	-0.6160	*****	*****	*****	*****	
-0.400	-0.0458	0.0021	0.0452	-0.1006	-0.5849	*****	*****	*****	*****	
-0.600	-0.0676	-0.0216	0.0165	-0.0804	-0.5702	*****	*****	*****	*****	
-0.700	-0.0690	-0.0561	-0.0051	-0.0794	-0.5875	*****	*****	*****	*****	
-0.800	-0.0541	*****	-0.0506	-0.0902	-0.7032	*****	*****	*****	*****	
-0.850	*****	-0.0849	-0.0797	-0.1197	-0.7413	*****	*****	*****	*****	
-0.900	*****	-0.0713	-0.0934	-0.1522	-0.5070	*****	*****	*****	*****	
-0.950	0.0499	-0.0202	-0.0593	-0.1376	-0.3799	*****	*****	*****	*****	
-0.975	*****	0.0334	-0.0080	-0.0815	-0.2579	*****	*****	*****	*****	
-1.000	0.1963	0.1901	0.1580	0.1523	0.0710	*****	*****	*****	*****	

Medium Radius L.E.
 Run No. = 20 , Point No. = 389
 $C_N = -0.016$, $C_m = 0.0015$
 $\alpha = -0.4^\circ$, $M_\infty = 0.852$
 $R_{mac} = 83.7 \times 10^6$

Leading Edge Pressures

● starboard
 ○ port

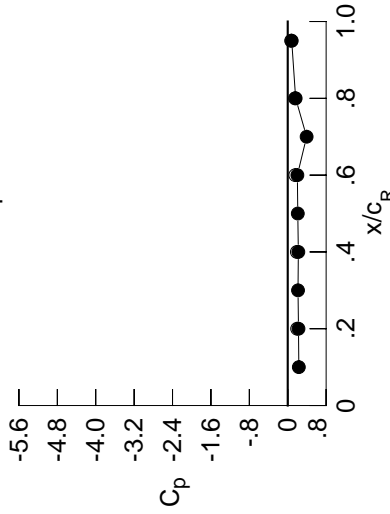

x/c_R	starb'd C_p	port C_p
0.10	0.2312	*****
0.20	0.2241	0.1963
0.30	0.2142	*****
0.40	0.2211	0.1901
0.50	0.2096	*****
0.60	0.2006	0.1580
0.70	0.3938	*****
0.80	0.1648	0.1523
0.90	*****	*****
0.95	0.0830	0.0710

Surface Pressures

● upper, starboard
 ○ lower, port

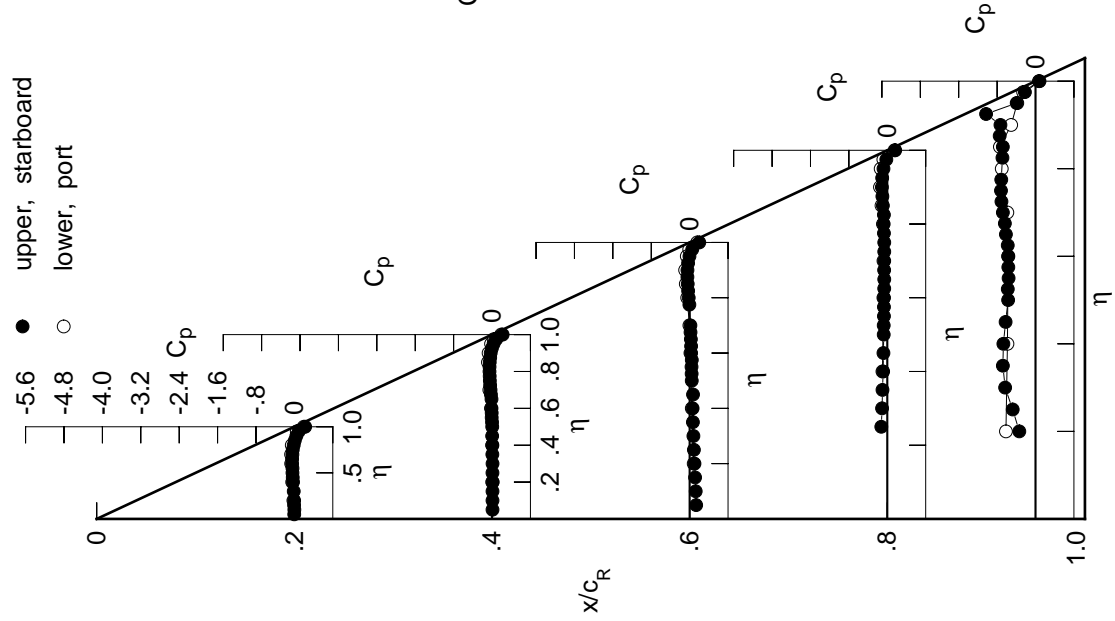

Table E8. Continued.

η	$x/c_R = .2$		$x/c_R = .4$		$x/c_R = .6$		$x/c_R = .8$		$x/c_R = .95$	
	$C_{p,u}$	$C_{p,u}$	$C_{p,u}$	$C_{p,u}$	$C_{p,u}$	$C_{p,u}$	$C_{p,u}$	$C_{p,u}$	$C_{p,u}$	$C_{p,u}$
0.050	-0.0241	-0.0081	0.1231	*****	*****	*****	*****	*****	*****	
0.100	-0.0212	-0.0084	0.1134	*****	*****	*****	*****	*****	*****	
0.150	-0.0257	-0.0080	0.1010	*****	*****	*****	*****	*****	*****	
0.200	-0.0263	-0.0039	0.0885	*****	*****	*****	*****	*****	-0.3038	
0.250	*****	-0.0090	0.0746	-0.1376	-0.4300	*****	*****	*****	*****	
0.300	-0.0348	-0.0091	0.0650	-0.1215	-0.6013	*****	*****	*****	*****	
0.350	*****	-0.0126	0.0537	-0.1124	-0.6772	*****	*****	*****	*****	
0.400	-0.0523	-0.0127	0.0466	-0.0999	-0.6762	*****	*****	*****	*****	
0.450	-0.0589	-0.0171	0.0551	-0.0938	-0.6311	*****	*****	*****	*****	
0.500	-0.0657	-0.0173	0.0269	-0.0886	-0.5650	*****	*****	*****	*****	
0.525	*****	-0.0222	0.0251	-0.0884	-0.5673	*****	*****	*****	*****	
0.550	-0.0677	-0.0301	0.0213	-0.0847	-0.5480	*****	*****	*****	*****	
0.575	*****	-0.0314	0.0266	-0.0853	-0.5526	*****	*****	*****	*****	
0.600	-0.0779	-0.0358	0.0107	-0.0856	-0.5505	*****	*****	*****	*****	
0.625	*****	*****	0.0111	-0.0812	-0.5628	*****	*****	*****	*****	
0.650	-0.0792	-0.0377	0.0051	-0.0809	-0.6017	*****	*****	*****	*****	
0.675	*****	-0.0514	-0.0031	-0.0841	-0.6270	*****	*****	*****	*****	
0.700	-0.0768	-0.0611	-0.0068	-0.0837	-0.6715	*****	*****	*****	*****	
0.725	*****	-0.0716	*****	-0.0834	-0.7040	*****	*****	*****	*****	
0.750	-0.0713	-0.0799	*****	-0.0850	-0.7021	*****	*****	*****	*****	
0.775	*****	-0.0868	-0.0346	-0.0938	-0.6554	*****	*****	*****	*****	
0.800	-0.0546	-0.0938	-0.0518	-0.1021	*****	*****	*****	*****	*****	
0.825	*****	-0.0958	-0.0676	-0.0979	-0.6134	*****	*****	*****	*****	
0.850	-0.0339	-0.0954	-0.0817	-0.1260	-0.6349	*****	*****	*****	*****	
0.875	*****	-0.0893	-0.0940	-0.1419	-0.7638	*****	*****	*****	*****	
0.900	-0.0041	-0.0824	-0.0988	-0.1601	-0.6406	*****	*****	*****	*****	
0.925	*****	-0.0630	-0.0923	-0.1621	-0.8773	*****	*****	*****	*****	
0.950	0.0432	-0.0296	-0.0700	-0.1443	-0.4293	*****	*****	*****	*****	
0.975	*****	0.0215	-0.0184	-0.0947	-0.2782	*****	*****	*****	*****	
1.000	0.2191	0.2132	0.1972	0.1535	0.0755	*****	*****	*****	*****	
η	$C_{p,l}$	$C_{p,l}$	$C_{p,l}$	$C_{p,l}$	$C_{p,l}$	$C_{p,l}$	$C_{p,l}$	$C_{p,l}$	$C_{p,l}$	
-0.200	-0.0015	0.0199	0.0975	*****	-0.6340	*****	*****	*****	*****	
-0.400	-0.0233	0.0197	0.0586	-0.0873	-0.6180	*****	*****	*****	*****	
-0.600	-0.0383	0.0010	0.0344	-0.0654	-0.6136	*****	*****	*****	*****	
-0.700	-0.0349	-0.0270	0.0161	-0.0608	-0.6352	*****	*****	*****	*****	
-0.800	-0.0139	*****	-0.0197	-0.0658	-0.7006	*****	*****	*****	*****	
-0.850	*****	-0.0398	-0.0400	-0.0875	-0.7358	*****	*****	*****	*****	
-0.900	*****	-0.0189	-0.0425	-0.1060	-0.5828	*****	*****	*****	*****	
-0.950	0.0972	0.0389	0.0038	-0.0742	-0.3449	*****	*****	*****	*****	
-0.975	*****	0.0969	0.0620	-0.0095	-0.2037	*****	*****	*****	*****	
-1.000	0.1973	0.1925	0.1617	0.1604	0.0773	*****	*****	*****	*****	

Medium Radius L.E.
 Run No. = 20 , Point No. = 390
 $C_N = 0.025$, $C_m = -0.0048$
 $\alpha = 0.7^\circ$, $M_\infty = 0.851$
 $R_{mac} = 84.1 \times 10^6$

Leading Edge Pressures

● starboard
 ○ port

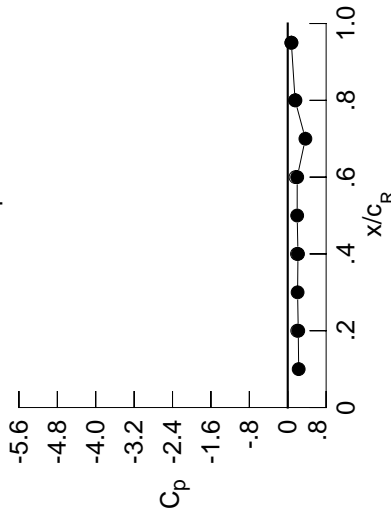

x/c_R	starb'd C_p	port C_p
0.10	0.2281	*****
0.20	0.2191	0.1973
0.30	0.2055	*****
0.40	0.2132	0.1925
0.50	0.1967	*****
0.60	0.1972	0.1617
0.70	0.3680	*****
0.80	0.1535	0.1604
0.90	*****	*****
0.95	0.0755	0.0773

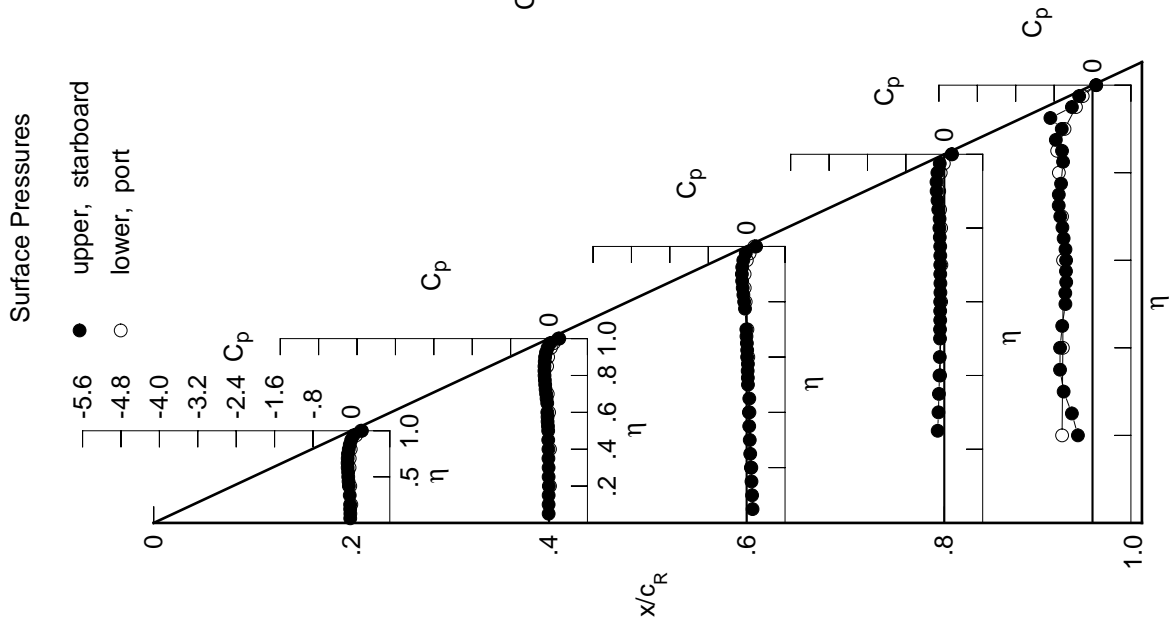
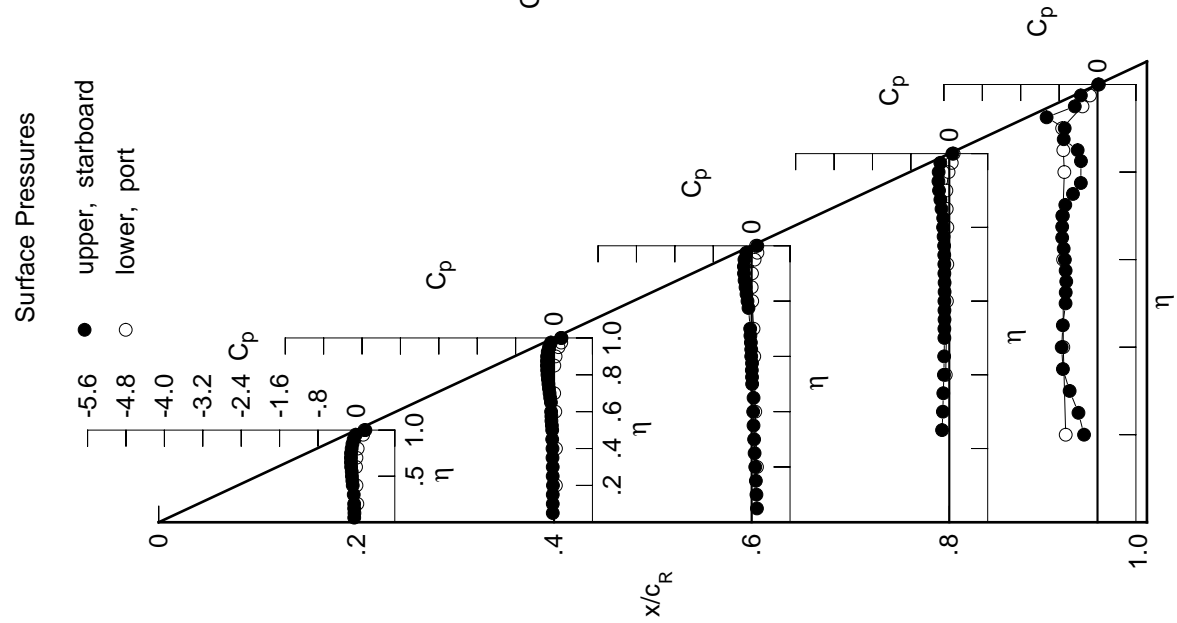

Table E8. Continued.

η	x/c_R .2	x/c_R .4	x/c_R .6	x/c_R .8	x/c_R .95
	$C_{p,u}$	$C_{p,u}$	$C_{p,u}$	$C_{p,u}$	$C_{p,u}$
0.050	-0.0446	-0.0261	0.1104	*****	*****
0.100	-0.0412	-0.0264	0.1004	*****	*****
0.150	-0.0462	-0.0261	0.0880	*****	*****
0.200	-0.0468	-0.0223	0.0748	*****	-0.2809
0.250	*****	-0.0279	0.0618	-0.1502	-0.3971
0.300	-0.0550	-0.0274	0.0515	-0.1339	-0.5808
0.350	*****	-0.0320	0.0388	-0.1251	-0.7205
0.400	-0.0759	-0.0323	0.0317	-0.1123	-0.7466
0.450	-0.0842	-0.0387	0.0397	-0.1068	-0.7227
0.500	-0.0929	-0.0388	0.0106	-0.1023	-0.6656
0.525	*****	-0.0449	0.0077	-0.1023	-0.6621
0.550	-0.0972	-0.0541	0.0038	-0.0995	-0.6510
0.575	*****	-0.0555	0.0083	-0.1005	-0.6637
0.600	-0.1094	-0.0611	-0.0084	-0.1016	-0.6800
0.625	*****	*****	-0.0090	-0.0978	-0.7048
0.650	-0.1138	-0.0645	-0.0161	-0.0976	-0.7357
0.675	*****	-0.0802	-0.0256	-0.1025	-0.7361
0.700	-0.1142	-0.0924	-0.0301	-0.1029	-0.7337
0.725	*****	-0.1052	*****	-0.1049	-0.6711
0.750	-0.1116	-0.1168	*****	-0.1078	-0.5108
0.775	*****	-0.1269	-0.0656	-0.1187	-0.3476
0.800	-0.0986	-0.1376	-0.0866	-0.1297	*****
0.825	*****	-0.1437	-0.1076	-0.1276	-0.3448
0.850	-0.0820	-0.1477	-0.1275	-0.1619	-0.4137
0.875	*****	-0.1469	-0.1469	-0.1857	-0.7044
0.900	-0.0565	-0.1446	-0.1596	-0.2137	-0.6842
0.925	*****	-0.1316	-0.1613	-0.2265	-1.0604
0.950	-0.0148	-0.1040	-0.1501	-0.2217	-0.4739
0.975	*****	-0.0652	-0.1111	-0.1874	-0.3472
1.000	0.1870	0.1556	0.1184	0.0638	0.0124
	$C_{p,l}$	$C_{p,l}$	$C_{p,l}$	$C_{p,l}$	$C_{p,l}$
-0.200	0.0200	0.0387	0.1114	*****	-0.6627
-0.400	0.0019	0.0404	0.0748	-0.0738	-0.7131
-0.600	-0.0068	0.0261	0.0541	-0.0493	-0.7168
-0.700	0.0010	0.0035	0.0396	-0.0413	-0.7217
-0.800	0.0265	*****	0.0123	-0.0407	-0.6915
-0.850	*****	0.0060	0.0006	-0.0539	-0.7122
-0.900	*****	0.0321	0.0072	-0.0608	-0.7368
-0.950	0.1409	0.0925	0.0614	-0.0154	-0.3128
-0.975	*****	0.1502	0.1201	0.0513	-0.1574
-1.000	0.1672	0.1445	0.0917	0.0902	0.0289

Medium Radius L.E.
 Run No. = 20, Point No. = 391
 $C_N = 0.066$, $C_m = -0.0103$
 $\alpha = 1.8^\circ$, $M_\infty = 0.851$
 $R_{mac} = 84.3 \times 10^6$



Leading Edge Pressures

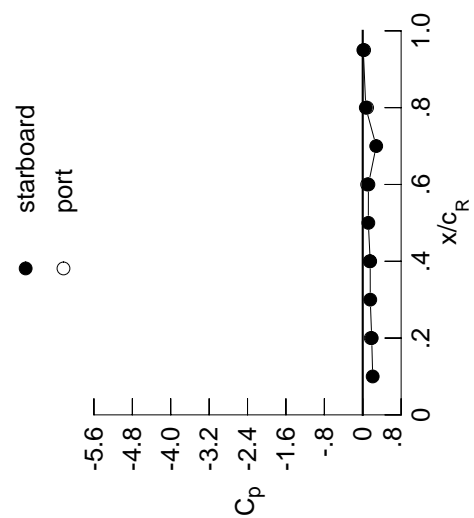

x/c_R	starb'd C_p	port C_p
0.10	0.2076	*****
0.20	0.1870	0.1672
0.30	0.1570	*****
0.40	0.1556	0.1445
0.50	0.1166	*****
0.60	0.1184	0.0917
0.70	0.2808	*****
0.80	0.0638	0.0902
0.90	*****	*****
0.95	0.0124	0.0289

Table E8. Continued.

η	$x/c_R = .2$		$x/c_R = .4$		$x/c_R = .6$		$x/c_R = .8$		$x/c_R = .95$	
	$C_{p,u}$	$C_{p,u}$	$C_{p,u}$	$C_{p,u}$	$C_{p,u}$	$C_{p,u}$	$C_{p,u}$	$C_{p,u}$	$C_{p,u}$	$C_{p,u}$
0.050	-0.0639	-0.0440	0.0975	*****	*****	*****	*****	*****	*****	
0.100	-0.0609	-0.0443	0.0880	*****	*****	*****	*****	*****	*****	
0.150	-0.0656	-0.0441	0.0749	*****	*****	*****	*****	*****	*****	
0.200	-0.0667	-0.0402	0.0622	*****	*****	*****	*****	*****	-0.2790	
0.250	*****	-0.0459	0.0479	-0.1627	-0.3848	*****	*****	*****	*****	
0.300	-0.0764	-0.0465	0.0374	-0.1471	-0.5504	*****	*****	*****	*****	
0.350	*****	-0.0515	0.0244	-0.1382	-0.7033	*****	*****	*****	*****	
0.400	-0.0995	-0.0522	0.0166	-0.1254	-0.7442	*****	*****	*****	*****	
0.450	-0.1094	-0.0596	0.0240	-0.1207	-0.7238	*****	*****	*****	*****	
0.500	-0.1198	-0.0610	-0.0063	-0.1167	-0.6696	*****	*****	*****	*****	
0.525	*****	-0.0674	-0.0096	-0.1174	-0.6667	*****	*****	*****	*****	
0.550	-0.1267	-0.0773	-0.0150	-0.1151	-0.6569	*****	*****	*****	*****	
0.575	*****	-0.0799	-0.0108	-0.1167	-0.6750	*****	*****	*****	*****	
0.600	-0.1408	-0.0868	-0.0282	-0.1182	-0.6969	*****	*****	*****	*****	
0.625	*****	*****	-0.0292	-0.1159	-0.7214	*****	*****	*****	*****	
0.650	-0.1489	-0.0925	-0.0373	-0.1167	-0.7423	*****	*****	*****	*****	
0.675	*****	-0.1099	-0.0483	-0.1227	-0.7245	*****	*****	*****	*****	
0.700	-0.1524	-0.1244	-0.0552	-0.1237	-0.6675	*****	*****	*****	*****	
0.725	*****	-0.1399	*****	-0.1270	-0.5303	*****	*****	*****	*****	
0.750	-0.1532	-0.1545	*****	-0.1320	-0.3810	*****	*****	*****	*****	
0.775	*****	-0.1682	-0.0968	-0.1451	-0.2560	*****	*****	*****	*****	
0.800	-0.1444	-0.1832	-0.1218	-0.1596	*****	*****	*****	*****	*****	
0.825	*****	-0.1935	-0.1476	-0.1584	-0.2766	*****	*****	*****	*****	
0.850	-0.1321	-0.2018	-0.1742	-0.1991	-0.3207	*****	*****	*****	*****	
0.875	*****	-0.2071	-0.2011	-0.2308	-0.5374	*****	*****	*****	*****	
0.900	-0.1126	-0.2103	-0.2232	-0.2695	-0.6516	*****	*****	*****	*****	
0.925	*****	-0.2043	-0.2351	-0.2939	-0.9551	*****	*****	*****	*****	
0.950	-0.0783	-0.1838	-0.2360	-0.3051	-0.5231	*****	*****	*****	*****	
0.975	*****	-0.1599	-0.2159	-0.2929	-0.4267	*****	*****	*****	*****	
1.000	0.1257	0.0488	-0.0005	-0.0956	-0.1095	*****	*****	*****	*****	
-0.200	$C_{p,l}$	$C_{p,l}$	$C_{p,l}$	$C_{p,l}$	$C_{p,l}$	$C_{p,l}$	$C_{p,l}$	$C_{p,l}$	$C_{p,l}$	
-0.400	0.0412	0.0563	0.1248	*****	-0.6781	*****	*****	*****	*****	
-0.600	0.0243	0.0587	0.0899	-0.0612	-0.7189	*****	*****	*****	*****	
-0.700	0.0209	0.0480	0.0716	-0.0345	-0.7217	*****	*****	*****	*****	
-0.800	0.0323	0.0303	0.0610	-0.0249	-0.7206	*****	*****	*****	*****	
-0.850	0.0611	*****	0.0402	-0.0186	-0.6756	*****	*****	*****	*****	
-0.900	*****	0.0442	0.0348	-0.0255	-0.6906	*****	*****	*****	*****	
-0.950	*****	0.0747	0.0485	-0.0221	-0.7259	*****	*****	*****	*****	
-0.975	0.1734	0.1337	0.1059	0.0315	-0.2862	*****	*****	*****	*****	
-1.000	*****	0.1847	0.1600	0.0953	-0.1211	*****	*****	*****	*****	
	0.1079	0.0452	-0.0581	-0.0516	-0.0680	*****	*****	*****	*****	

Medium Radius L.E.
 Run No. = 20 , Point No. = 392
 $C_N = 0.108$, $C_m = -0.0171$
 $\alpha = 2.9^\circ$, $M_\infty = 0.851$
 $R_{mac} = 84.4 \times 10^6$

Leading Edge Pressures

● starboard
 ○ port

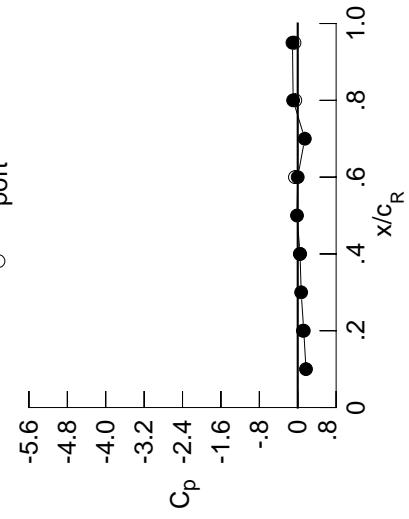

x/c_R	starb'd C_p	port C_p
0.10	0.1720	*****
0.20	0.1257	0.1079
0.30	0.0712	*****
0.40	0.0488	0.0452
0.50	-0.0156	*****
0.60	-0.0005	-0.0581
0.70	0.1469	*****
0.80	-0.0956	-0.0516
0.90	*****	*****
0.95	-0.1095	-0.0680

Surface Pressures

● upper, starboard
 ○ lower, port

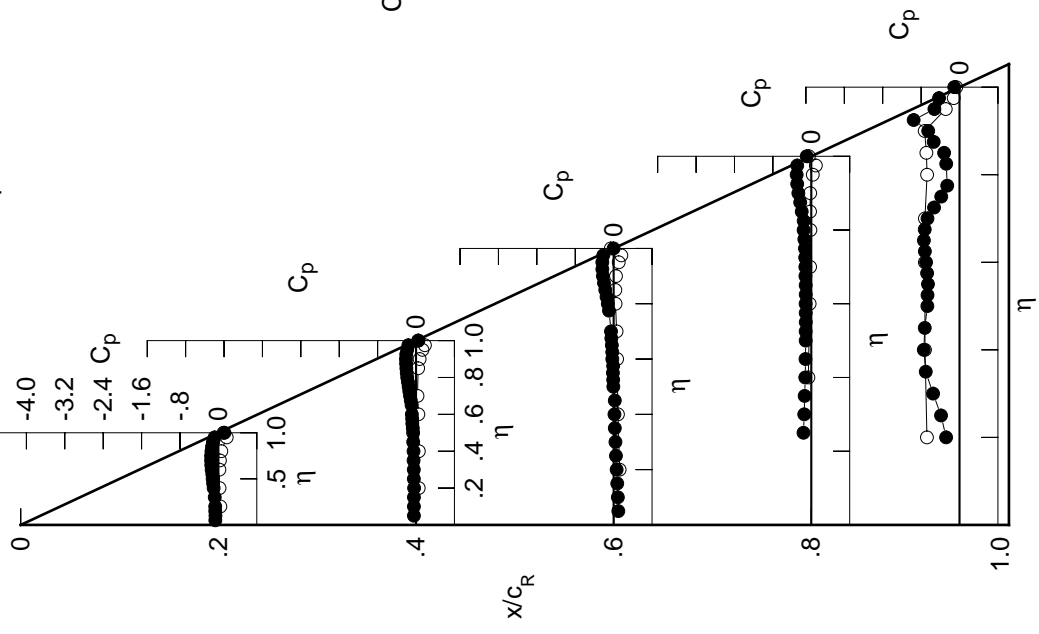

Table E8. Continued.

η	$x/c_R = .2$		$x/c_R = .4$		$x/c_R = .6$		$x/c_R = .8$		$x/c_R = .95$	
	$C_{p,u}$	$C_{p,l}$	$C_{p,u}$	$C_{p,l}$	$C_{p,u}$	$C_{p,l}$	$C_{p,u}$	$C_{p,l}$	$C_{p,u}$	$C_{p,l}$
0.050	-0.0831	-0.0615	0.0855	*****	*****	*****	*****	*****	*****	*****
0.100	-0.0807	-0.0612	0.0758	*****	*****	*****	*****	*****	*****	*****
0.150	-0.0851	-0.0615	0.0633	*****	*****	*****	*****	*****	*****	*****
0.200	-0.0869	-0.0587	0.0501	*****	*****	*****	*****	*****	*****	*****
0.250	*****	-0.0644	0.0354	-0.1744	-0.3789	*****	*****	*****	*****	*****
0.300	-0.0968	-0.0647	0.0246	-0.1582	-0.5196	*****	*****	*****	*****	*****
0.350	*****	-0.0704	0.0113	-0.1498	-0.6789	*****	*****	*****	*****	*****
0.400	-0.1224	-0.0721	0.0020	-0.1378	-0.7340	*****	*****	*****	*****	*****
0.450	-0.1339	-0.0797	0.0084	-0.1339	-0.7194	*****	*****	*****	*****	*****
0.500	-0.1459	-0.0827	-0.0225	-0.1301	-0.6752	*****	*****	*****	*****	*****
0.525	*****	-0.0898	-0.0267	-0.1314	-0.6757	*****	*****	*****	*****	*****
0.550	-0.1560	-0.1011	-0.0321	-0.1294	-0.6691	*****	*****	*****	*****	*****
0.575	*****	-0.1050	-0.0288	-0.1313	-0.6886	*****	*****	*****	*****	*****
0.600	-0.1727	-0.1129	-0.0470	-0.1343	-0.7081	*****	*****	*****	*****	*****
0.625	*****	*****	-0.0499	-0.1323	-0.7250	*****	*****	*****	*****	*****
0.650	-0.1837	-0.1200	-0.0589	-0.1340	-0.7319	*****	*****	*****	*****	*****
0.675	*****	-0.1395	-0.0703	-0.1411	-0.6718	*****	*****	*****	*****	*****
0.700	-0.1910	-0.1557	-0.0781	-0.1438	-0.5505	*****	*****	*****	*****	*****
0.725	*****	-0.1747	*****	-0.1485	-0.4260	*****	*****	*****	*****	*****
0.750	-0.1962	-0.1931	*****	-0.1555	-0.3135	*****	*****	*****	*****	*****
0.775	*****	-0.2109	-0.1284	-0.1708	-0.2137	*****	*****	*****	*****	*****
0.800	-0.1920	-0.2296	-0.1577	-0.1887	*****	*****	*****	*****	*****	*****
0.825	*****	-0.2451	-0.1895	-0.1904	-0.2491	*****	*****	*****	*****	*****
0.850	-0.1852	-0.2586	-0.2221	-0.2371	-0.2753	*****	*****	*****	*****	*****
0.875	*****	-0.2698	-0.2580	-0.2772	-0.4256	*****	*****	*****	*****	*****
0.900	-0.1732	-0.2809	-0.2903	-0.3276	-0.6392	*****	*****	*****	*****	*****
0.925	*****	-0.2842	-0.3149	-0.3662	-0.8628	*****	*****	*****	*****	*****
0.950	-0.1499	-0.2753	-0.3332	-0.3963	-0.5770	*****	*****	*****	*****	*****
0.975	*****	-0.2716	-0.3364	-0.4132	-0.5191	*****	*****	*****	*****	*****
1.000	0.0325	-0.1143	-0.1689	-0.3245	-0.2848	*****	*****	*****	*****	*****
-0.200	$C_{p,l}$	$C_{p,l}$	$C_{p,l}$	$C_{p,l}$	$C_{p,l}$	$C_{p,l}$	$C_{p,l}$	$C_{p,l}$	$C_{p,l}$	$C_{p,l}$
-0.400	0.0634	0.0747	0.1386	*****	*****	*****	*****	*****	*****	*****
-0.600	0.0485	0.0785	0.1056	-0.0474	-0.7326	*****	*****	*****	*****	*****
-0.700	0.0500	0.0720	0.0899	-0.0188	-0.7300	*****	*****	*****	*****	*****
-0.800	0.0644	0.0577	0.0823	-0.0065	-0.7128	*****	*****	*****	*****	*****
-0.850	0.0952	*****	0.0671	0.0042	-0.6581	*****	*****	*****	*****	*****
-0.900	*****	0.0808	0.0673	0.0018	-0.6689	*****	*****	*****	*****	*****
-0.950	*****	0.1130	0.0862	0.0130	-0.6879	*****	*****	*****	*****	*****
-0.975	*****	0.2010	0.1674	0.1434	0.0702	-0.2637	*****	*****	*****	*****
-1.000	*****	0.2068	0.1880	0.1268	-0.0943	*****	*****	*****	*****	*****
	0.0154	-0.0941	-0.2756	-0.2615	-0.2091	*****	*****	*****	*****	*****

Medium Radius L.E.
 Run No. = 20 , Point No. = 393
 $C_N = 0.151$, $C_m = -0.0247$
 $\alpha = 3.9^\circ$, $M_\infty = 0.852$
 $R_{mac} = 84.6 \times 10^6$

Leading Edge Pressures

● starboard
 ○ port

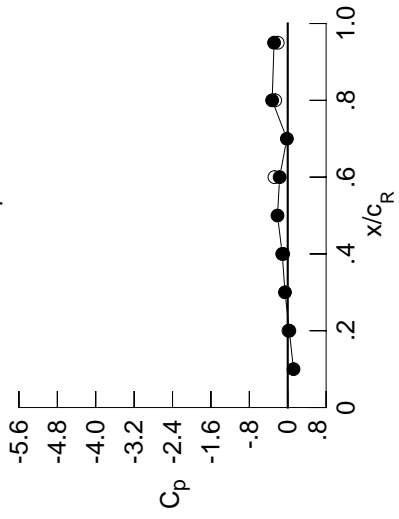

x/c_R	starb'd C_p	port C_p
0.10	0.1200	*****
0.20	0.0325	0.0154
0.30	-0.0578	*****
0.40	-0.1143	-0.0941
0.50	-0.2131	*****
0.60	-0.1689	-0.2756
0.70	-0.0178	*****
0.80	-0.3245	-0.2615
0.90	*****	*****
0.95	-0.2848	-0.2091

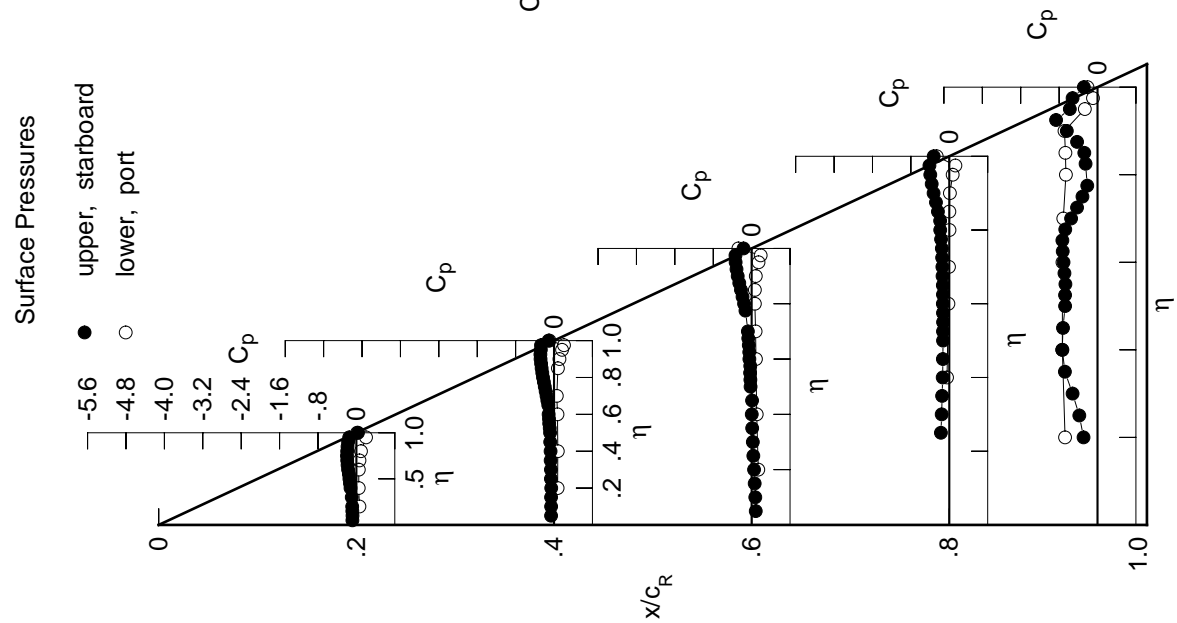

Table E8. Continued.

η	$x/c_R = .2$		$x/c_R = .4$		$x/c_R = .6$		$x/c_R = .8$		$x/c_R = .95$	
	$C_{p,u}$	$C_{p,u}$	$C_{p,u}$	$C_{p,u}$	$C_{p,u}$	$C_{p,u}$	$C_{p,u}$	$C_{p,u}$	$C_{p,u}$	$C_{p,u}$
0.050	-0.1012	-0.0768	0.0751	*****	*****	*****	*****	*****	*****	
0.100	-0.0990	-0.0774	0.0652	*****	*****	*****	*****	*****	*****	
0.150	-0.1036	-0.0783	0.0526	*****	*****	*****	*****	*****	*****	
0.200	-0.1052	-0.0751	0.0388	*****	*****	*****	*****	*****	-0.2926	
0.250	*****	-0.0815	0.0242	-0.1856	-0.3605	*****	*****	*****	*****	
0.300	-0.1167	-0.0824	0.0125	-0.1705	-0.4765	*****	*****	*****	*****	
0.350	*****	-0.0892	-0.0019	-0.1614	-0.6274	*****	*****	*****	*****	
0.400	-0.1443	-0.0906	-0.0115	-0.1502	-0.7152	*****	*****	*****	*****	
0.450	-0.1576	-0.1006	-0.0060	-0.1461	-0.7163	*****	*****	*****	*****	
0.500	-0.1717	-0.1036	-0.0379	-0.1438	-0.6824	*****	*****	*****	*****	
0.525	*****	-0.1127	-0.0423	-0.1456	-0.6835	*****	*****	*****	*****	
0.550	-0.1840	-0.1236	-0.0493	-0.1443	-0.6760	*****	*****	*****	*****	
0.575	*****	-0.1290	-0.0470	-0.1470	-0.6918	*****	*****	*****	*****	
0.600	-0.2034	-0.1376	-0.0660	-0.1502	-0.7057	*****	*****	*****	*****	
0.625	*****	*****	-0.0694	-0.1491	-0.7085	*****	*****	*****	*****	
0.650	-0.2185	-0.1476	-0.0796	-0.1522	-0.6877	*****	*****	*****	*****	
0.675	*****	-0.1687	-0.0930	-0.1595	-0.5850	*****	*****	*****	*****	
0.700	-0.2293	-0.1886	-0.1026	-0.1641	-0.4703	*****	*****	*****	*****	
0.725	*****	-0.2097	*****	-0.1710	-0.3807	*****	*****	*****	*****	
0.750	-0.2394	-0.2314	*****	-0.1796	-0.2835	*****	*****	*****	*****	
0.775	*****	-0.2534	-0.1604	-0.1980	-0.1994	*****	*****	*****	*****	
0.800	-0.2403	-0.2768	-0.1945	-0.2187	*****	*****	*****	*****	*****	
0.825	*****	-0.2983	-0.2310	-0.2245	-0.2425	*****	*****	*****	*****	
0.850	-0.2398	-0.3181	-0.2720	-0.2761	-0.2665	*****	*****	*****	*****	
0.875	*****	-0.3368	-0.3171	-0.3253	-0.3909	*****	*****	*****	*****	
0.900	-0.2360	-0.3553	-0.3633	-0.3884	-0.6399	*****	*****	*****	*****	
0.925	*****	-0.3695	-0.3993	-0.4435	-0.7962	*****	*****	*****	*****	
0.950	-0.2268	-0.3757	-0.4374	-0.4949	-0.6393	*****	*****	*****	*****	
0.975	*****	-0.3967	-0.4779	-0.5479	-0.6222	*****	*****	*****	*****	
1.000	-0.0874	-0.3138	-0.3778	-0.6280	-0.5289	*****	*****	*****	*****	
	$C_{p,l}$	$C_{p,l}$	$C_{p,l}$	$C_{p,l}$	$C_{p,l}$	$C_{p,l}$	$C_{p,l}$	$C_{p,l}$	$C_{p,l}$	
-0.200	0.0862	0.0953	0.1541	*****	-0.6707	*****	*****	*****	*****	
-0.400	0.0731	0.0994	0.1226	-0.0334	-0.7259	*****	*****	*****	*****	
-0.600	0.0791	0.0958	0.1091	-0.0021	-0.7249	*****	*****	*****	*****	
-0.700	0.0957	0.0847	0.1041	0.0114	-0.7008	*****	*****	*****	*****	
-0.800	0.1277	*****	0.0940	0.0267	-0.6415	*****	*****	*****	*****	
-0.850	*****	0.1152	0.0983	0.0281	-0.6486	*****	*****	*****	*****	
-0.900	*****	0.1474	0.1201	0.0450	-0.6551	*****	*****	*****	*****	
-0.950	0.2217	0.1948	0.1726	0.1028	-0.2439	*****	*****	*****	*****	
-0.975	*****	0.2187	0.2034	0.1476	-0.0746	*****	*****	*****	*****	
-1.000	-0.1008	-0.2730	-0.5610	-0.5535	-0.4100	*****	*****	*****	*****	

Medium Radius L.E.
 Run No. = 20 , Point No. = 394
 $C_N = 0.194$, $C_m = -0.0317$
 $\alpha = 5.0^\circ$, $M_\infty = 0.852$
 $R_{mac} = 84.7 \times 10^6$

Leading Edge Pressures

● starboard
 ○ port

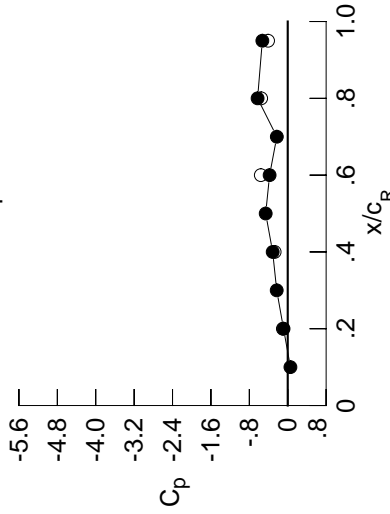

x/c_R	starb'd C_p	port C_p
0.10	0.0564	*****
0.20	-0.0874	-0.1008
0.30	-0.2294	*****
0.40	-0.3138	-0.2730
0.50	-0.4593	*****
0.60	-0.3778	-0.5610
0.70	-0.2272	*****
0.80	-0.6280	-0.5535
0.90	*****	*****
0.95	-0.5289	-0.4100

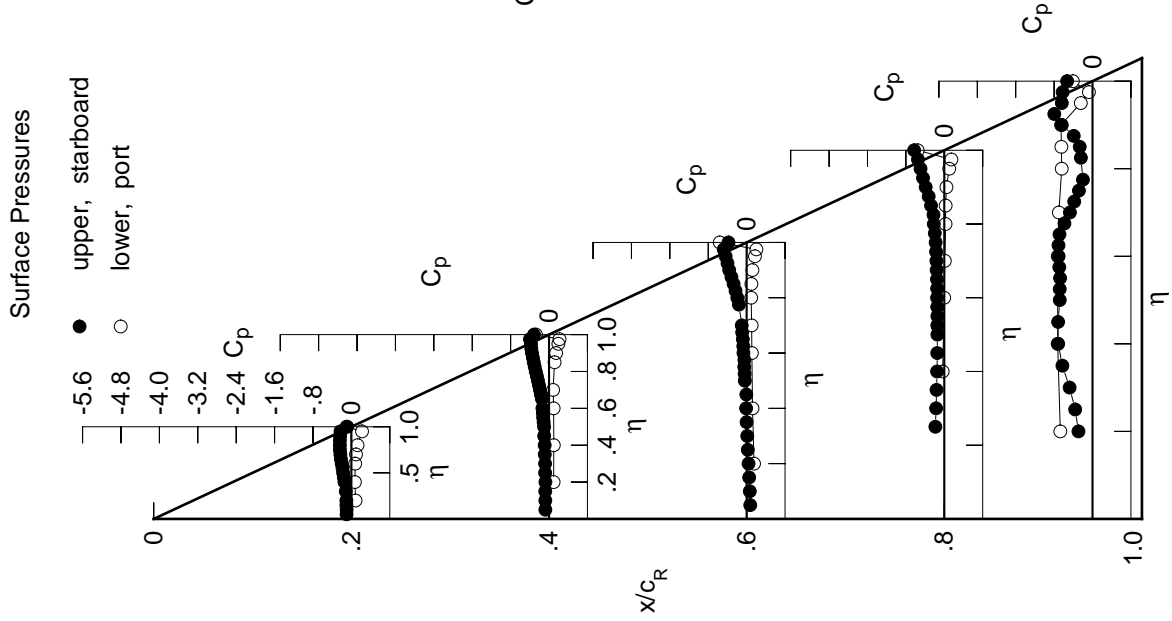

Table E8. Continued.

η	$x/c_R = .2$		$x/c_R = .4$		$x/c_R = .6$		$x/c_R = .8$		$x/c_R = .95$	
	$C_{p,u}$	$C_{p,u}$	$C_{p,u}$	$C_{p,u}$	$C_{p,u}$	$C_{p,u}$	$C_{p,u}$	$C_{p,u}$	$C_{p,u}$	$C_{p,u}$
0.050	-0.1182	-0.0934	0.0635	*****	*****	*****	*****	*****	*****	
0.100	-0.1170	-0.0943	0.0540	*****	*****	*****	*****	*****	*****	
0.150	-0.1221	-0.0957	0.0411	*****	*****	*****	*****	*****	*****	
0.200	-0.1248	-0.0917	0.0271	*****	*****	*****	*****	*****	-0.2940	
0.250	*****	-0.0988	0.0113	-0.1966	-0.1807	-0.4255	*****	*****	*****	
0.300	-0.1367	-0.1005	0.0003	-0.1807	-0.1729	-0.5340	*****	*****	*****	
0.350	*****	-0.1083	-0.0150	-0.1729	-0.1617	-0.6382	*****	*****	*****	
0.400	-0.1670	-0.1102	-0.0259	-0.1617	-0.1587	-0.6649	*****	*****	*****	
0.450	-0.1819	-0.1218	-0.0216	-0.1587	-0.1576	-0.6616	*****	*****	*****	
0.500	-0.1984	-0.1260	-0.0533	-0.1576	-0.1587	-0.6736	*****	*****	*****	
0.525	*****	-0.1360	-0.0599	-0.1587	-0.1662	-0.6818	*****	*****	*****	
0.550	-0.2130	-0.1483	-0.0663	-0.1587	-0.1658	-0.6670	*****	*****	*****	
0.575	*****	-0.1542	-0.0653	-0.1610	-0.1662	-0.6818	*****	*****	*****	
0.600	-0.2365	-0.1641	-0.0858	-0.1662	-0.1658	-0.6670	*****	*****	*****	
0.625	*****	*****	-0.0900	-0.1658	-0.1702	-0.6139	*****	*****	*****	
0.650	-0.2553	-0.1764	-0.1016	-0.1702	-0.1798	-0.5123	*****	*****	*****	
0.675	*****	-0.1994	-0.1161	-0.1798	-0.1854	-0.4354	*****	*****	*****	
0.700	-0.2707	-0.2219	-0.1278	-0.1854	-0.1953	-0.3664	*****	*****	*****	
0.725	*****	-0.2459	*****	-0.1953	-0.2074	-0.2770	*****	*****	*****	
0.750	-0.2860	-0.2719	*****	-0.2074	-0.2298	-0.2006	*****	*****	*****	
0.775	*****	-0.2979	-0.1950	-0.2298	-0.2522	*****	*****	*****	*****	
0.800	-0.2936	-0.3281	-0.2335	-0.2522	-0.2611	-0.2325	*****	*****	*****	
0.825	*****	-0.3545	-0.2758	-0.2611	-0.3152	-0.2598	*****	*****	*****	
0.850	-0.3005	-0.3818	-0.3243	-0.3152	-0.3714	-0.3496	*****	*****	*****	
0.875	*****	-0.4089	-0.3812	-0.3714	-0.4461	-0.6279	*****	*****	*****	
0.900	-0.3076	-0.4387	-0.4401	-0.4461	-0.5191	-0.7534	*****	*****	*****	
0.925	*****	-0.4666	-0.4940	-0.5191	-0.6002	-0.7040	*****	*****	*****	
0.950	-0.3159	-0.4902	-0.5525	-0.6002	-0.7030	-0.7430	*****	*****	*****	
0.975	*****	-0.5519	-0.6228	-0.7030	-0.9403	-0.8048	*****	*****	*****	
1.000	-0.2388	-0.5786	-0.6174	-0.9403	-0.8048	-0.8048	*****	*****	*****	
-0.200	$C_{p,l}$	$C_{p,l}$	$C_{p,l}$	$C_{p,l}$	$C_{p,l}$	$C_{p,l}$	$C_{p,l}$	$C_{p,l}$	$C_{p,l}$	
-0.400	0.1095	0.1154	0.1692	*****	*****	-0.6607	*****	*****	*****	
-0.600	0.0987	0.1208	0.1398	-0.0180	-0.7349	*****	*****	*****	*****	
-0.700	0.1082	0.1201	0.1279	0.0138	-0.7164	*****	*****	*****	*****	
-0.800	0.1266	0.1121	0.1258	0.0287	-0.6904	*****	*****	*****	*****	
-0.850	0.1588	*****	0.1196	0.0478	-0.6280	*****	*****	*****	*****	
-0.900	*****	0.1480	0.1271	0.0524	-0.6313	*****	*****	*****	*****	
-0.950	0.2374	0.2157	0.1500	0.0736	-0.6275	*****	*****	*****	*****	
-0.975	*****	0.2206	0.1954	0.1283	-0.2292	*****	*****	*****	*****	
-1.000	-0.2499	-0.4920	-0.8146	-0.8657	-0.6954	*****	*****	*****	*****	

Medium Radius L.E.
 Run No. = 20 , Point No. = 395
 $C_N = 0.238$, $C_m = -0.0380$
 $\alpha = 6.1^\circ$, $M_\infty = 0.850$
 $R_{mac} = 84.7 \times 10^6$

Leading Edge Pressures

● starboard
 ○ port

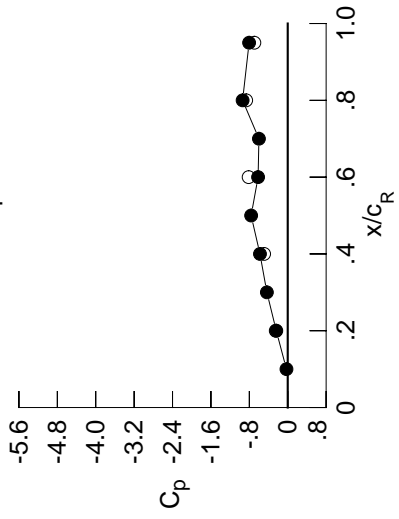

x/c_R	starb'd C_p	port C_p
0.10	-0.0268	*****
0.20	-0.2388	-0.2499
0.30	-0.4343	*****
0.40	-0.5786	-0.4920
0.50	-0.7627	*****
0.60	-0.6174	-0.8146
0.70	-0.6002	*****
0.80	-0.9403	-0.8657
0.90	*****	*****
0.95	-0.8048	-0.6954

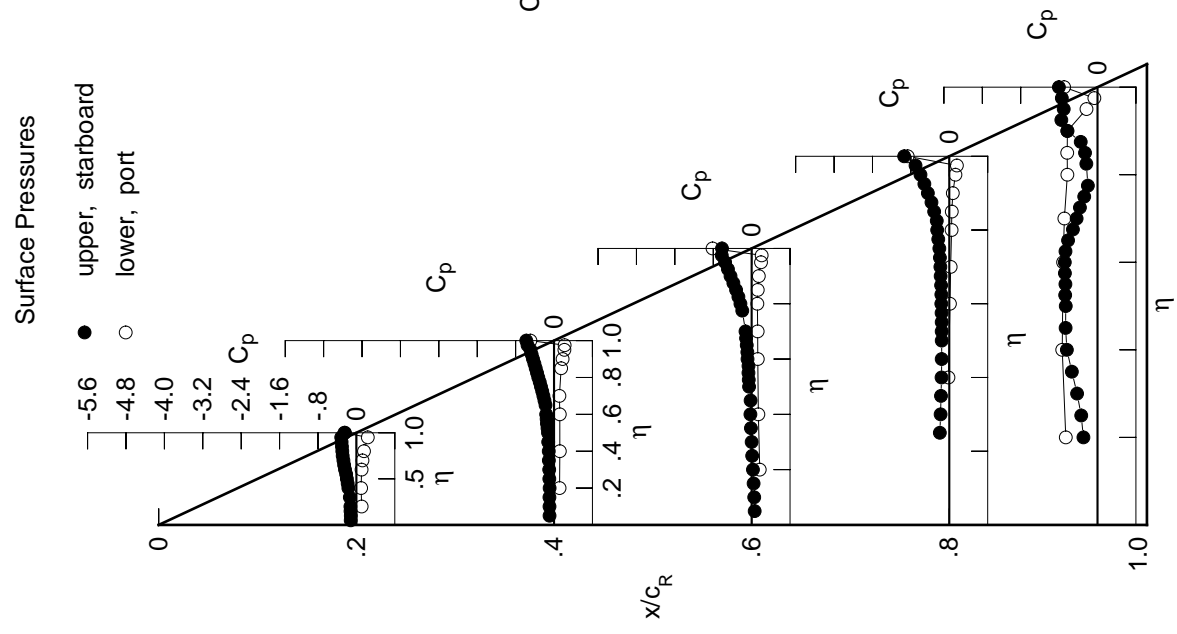

Table E8. Continued.

η	$x/c_R = .2$		$x/c_R = .4$		$x/c_R = .6$		$x/c_R = .8$		$x/c_R = .95$	
	$C_{p,u}$	$C_{p,u}$	$C_{p,u}$	$C_{p,u}$	$C_{p,u}$	$C_{p,u}$	$C_{p,u}$	$C_{p,u}$	$C_{p,u}$	$C_{p,u}$
0.050	-0.1374	-0.1105	0.0522	*****	*****	*****	*****	*****	*****	*****
0.100	-0.1376	-0.1122	0.0414	*****	*****	*****	*****	*****	*****	*****
0.150	-0.1421	-0.1134	0.0284	*****	*****	*****	*****	*****	*****	*****
0.200	-0.1453	-0.1105	0.0145	*****	*****	*****	*****	*****	*****	*****
0.250	*****	-0.1181	-0.0019	-0.2103	-0.3402	*****	*****	*****	*****	*****
0.300	-0.1577	-0.1199	-0.0138	-0.1945	-0.4030	*****	*****	*****	*****	*****
0.350	*****	-0.1284	-0.0292	-0.1873	-0.4816	*****	*****	*****	*****	*****
0.400	-0.1904	-0.1318	-0.0414	-0.1761	-0.5921	*****	*****	*****	*****	*****
0.450	-0.2075	-0.1439	-0.0375	-0.1739	-0.6526	*****	*****	*****	*****	*****
0.500	-0.2262	-0.1504	-0.0713	-0.1726	-0.7249	*****	*****	*****	*****	*****
0.525	*****	-0.1608	-0.0778	-0.1741	-0.7539	*****	*****	*****	*****	*****
0.550	-0.2438	-0.1738	-0.0854	-0.1736	-0.7526	*****	*****	*****	*****	*****
0.575	*****	-0.1810	-0.0849	-0.1784	-0.7581	*****	*****	*****	*****	*****
0.600	-0.2703	-0.1933	-0.1079	-0.1858	-0.7424	*****	*****	*****	*****	*****
0.625	*****	*****	-0.1134	-0.1897	-0.7047	*****	*****	*****	*****	*****
0.650	-0.2931	-0.2090	-0.1281	-0.1987	-0.6496	*****	*****	*****	*****	*****
0.675	*****	-0.2335	-0.1454	-0.2121	-0.5657	*****	*****	*****	*****	*****
0.700	-0.3136	-0.2581	-0.1612	-0.2257	-0.5042	*****	*****	*****	*****	*****
0.725	*****	-0.2855	*****	-0.2395	-0.4454	*****	*****	*****	*****	*****
0.750	-0.3345	-0.3143	*****	-0.2544	-0.3726	*****	*****	*****	*****	*****
0.775	*****	-0.3453	-0.2358	-0.2753	-0.2784	*****	*****	*****	*****	*****
0.800	-0.3498	-0.3799	-0.2729	-0.2974	*****	*****	*****	*****	*****	*****
0.825	*****	-0.4139	-0.3175	-0.3111	-0.2632	*****	*****	*****	*****	*****
0.850	-0.3648	-0.4494	-0.3694	-0.3513	-0.2708	*****	*****	*****	*****	*****
0.875	*****	-0.4873	-0.4316	-0.3996	-0.3137	*****	*****	*****	*****	*****
0.900	-0.3852	-0.5274	-0.5014	-0.4875	-0.4831	*****	*****	*****	*****	*****
0.925	*****	-0.5706	-0.5696	-0.5746	-0.7864	*****	*****	*****	*****	*****
0.950	-0.4107	-0.6109	-0.6454	-0.6725	-0.7072	*****	*****	*****	*****	*****
0.975	*****	-0.7064	-0.7771	-0.8637	-0.7723	*****	*****	*****	*****	*****
1.000	-0.4131	-0.8451	-0.7895	-1.1550	-1.0005	*****	*****	*****	*****	*****
η	$C_{p,l}$	$C_{p,l}$	$C_{p,l}$	$C_{p,l}$	$C_{p,l}$	$C_{p,l}$	$C_{p,l}$	$C_{p,l}$	$C_{p,l}$	$C_{p,l}$
-0.200	0.1327	0.1356	0.1843	*****	*****	*****	*****	*****	*****	*****
-0.400	0.1240	0.1419	0.1554	-0.0041	-0.7254	*****	*****	*****	*****	*****
-0.600	0.1361	0.1431	0.1461	0.0291	-0.7031	*****	*****	*****	*****	*****
-0.700	0.1561	0.1379	0.1455	0.0459	-0.6771	*****	*****	*****	*****	*****
-0.800	0.1876	*****	0.1431	0.0664	-0.6115	*****	*****	*****	*****	*****
-0.850	*****	0.1768	0.1527	0.0740	-0.6130	*****	*****	*****	*****	*****
-0.900	*****	0.2039	0.1754	0.1000	-0.6017	*****	*****	*****	*****	*****
-0.950	0.2453	0.2283	0.2099	0.1465	-0.2177	*****	*****	*****	*****	*****
-0.975	*****	0.2118	0.2039	0.1597	-0.0629	*****	*****	*****	*****	*****
-1.000	-0.4300	-0.7197	-1.0175	-1.0565	-0.8817	*****	*****	*****	*****	*****

Medium Radius L.E.

Run No. = 20 , Point No. = 396

$C_N = 0.285$, $C_m = -0.0468$

$\alpha = 7.1^\circ$, $M_\infty = 0.851$

$R_{mac} = 84.8 \times 10^6$

Leading Edge Pressures

● starboard
○ port

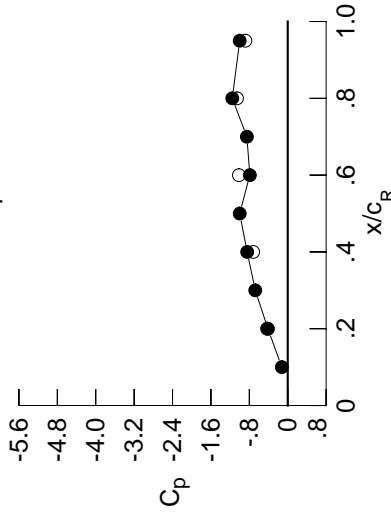

x/c_R	starb'd C_p	port C_p
0.10	-0.1236	*****
0.20	-0.4131	-0.4300
0.30	-0.6765	*****
0.40	-0.8451	-0.7197
0.50	-1.0004	*****
0.60	-0.7895	-1.0175
0.70	-0.8512	*****
0.80	-1.1550	-1.0565
0.90	*****	*****
0.95	-1.0005	-0.8817

Surface Pressures

● upper, starboard
○ lower, port

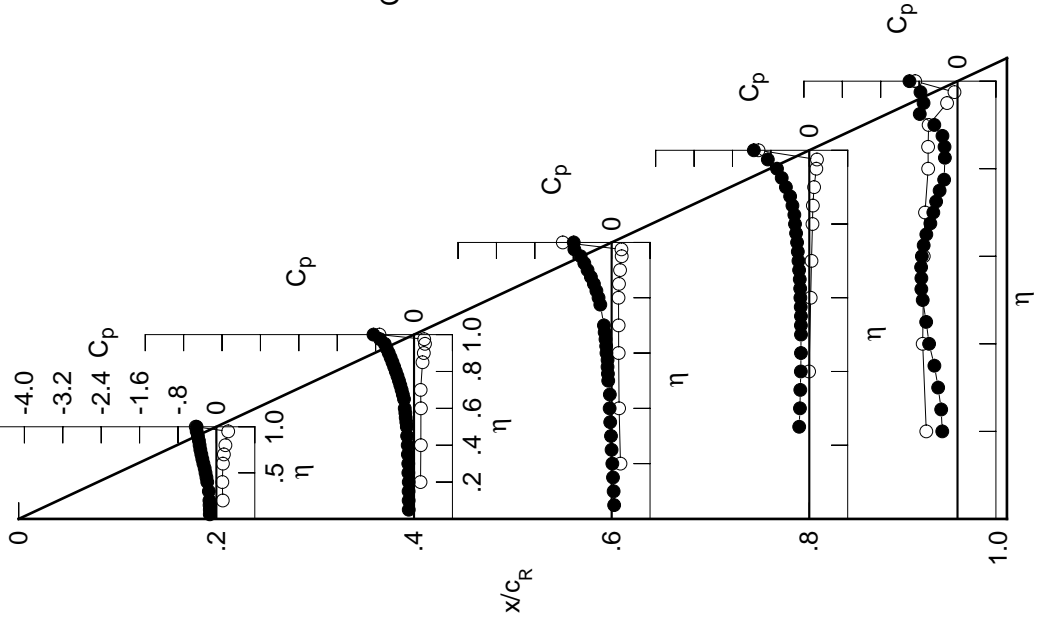

Table E8. Continued.

η	$x/c_R = .2$		$x/c_R = .4$		$x/c_R = .6$		$x/c_R = .8$		$x/c_R = .95$	
	$C_{p,u}$	$C_{p,u}$	$C_{p,u}$	$C_{p,u}$	$C_{p,u}$	$C_{p,u}$	$C_{p,u}$	$C_{p,u}$	$C_{p,u}$	$C_{p,u}$
0.050	-0.1522	-0.1277	0.0376	*****	*****	*****	*****	*****	*****	*****
0.100	-0.1541	-0.1292	0.0273	*****	*****	*****	*****	*****	*****	*****
0.150	-0.1602	-0.1314	0.0136	*****	*****	*****	*****	*****	*****	*****
0.200	-0.1641	-0.1286	-0.0002	*****	*****	*****	*****	*****	*****	*****
0.250	*****	-0.1362	-0.0171	-0.2347	-0.3348	*****	*****	*****	*****	*****
0.300	-0.1775	-0.1397	-0.0297	-0.2185	-0.3781	*****	*****	*****	*****	*****
0.350	*****	-0.1487	-0.0449	-0.2111	-0.4923	*****	*****	*****	*****	*****
0.400	-0.2123	-0.1524	-0.0587	-0.1982	-0.6967	*****	*****	*****	*****	*****
0.450	-0.2310	-0.1661	-0.0542	-0.1988	-0.7343	*****	*****	*****	*****	*****
0.500	-0.2521	-0.1726	-0.0920	-0.2011	-0.7027	*****	*****	*****	*****	*****
0.525	*****	-0.1860	-0.1023	-0.2048	-0.6990	*****	*****	*****	*****	*****
0.550	-0.2724	-0.2018	-0.1143	-0.2081	-0.6627	*****	*****	*****	*****	*****
0.575	*****	-0.2124	-0.1180	-0.2160	-0.6433	*****	*****	*****	*****	*****
0.600	-0.3022	-0.2250	-0.1430	-0.2256	-0.6254	*****	*****	*****	*****	*****
0.625	*****	*****	-0.1508	-0.2317	-0.6142	*****	*****	*****	*****	*****
0.650	-0.3294	-0.2437	-0.1677	-0.2385	-0.6073	*****	*****	*****	*****	*****
0.675	*****	-0.2688	-0.1882	-0.2455	-0.5747	*****	*****	*****	*****	*****
0.700	-0.3550	-0.2942	-0.2035	-0.2571	-0.5807	*****	*****	*****	*****	*****
0.725	*****	-0.3224	*****	-0.2960	-0.6087	*****	*****	*****	*****	*****
0.750	-0.3814	-0.3540	*****	-0.3296	-0.6217	*****	*****	*****	*****	*****
0.775	*****	-0.3888	-0.2736	-0.3227	-0.6564	*****	*****	*****	*****	*****
0.800	-0.4051	-0.4283	-0.3129	-0.3253	*****	*****	*****	*****	*****	*****
0.825	*****	-0.4691	-0.3564	-0.3531	-0.7566	*****	*****	*****	*****	*****
0.850	-0.4317	-0.5110	-0.4091	-0.5089	-0.8057	*****	*****	*****	*****	*****
0.875	*****	-0.5565	-0.4776	-0.5168	-0.8598	*****	*****	*****	*****	*****
0.900	-0.4627	-0.6074	-0.5727	-0.6083	-0.8104	*****	*****	*****	*****	*****
0.925	*****	-0.6629	-0.7320	-0.7619	-0.7367	*****	*****	*****	*****	*****
0.950	-0.5208	-0.7072	-0.9312	-0.8945	-0.6387	*****	*****	*****	*****	*****
0.975	*****	-0.9361	-1.1021	-0.9543	-0.7941	*****	*****	*****	*****	*****
1.000	-0.6130	-1.0409	-0.8767	-1.2357	-1.1158	*****	*****	*****	*****	*****
-0.200	$C_{p,l}$	$C_{p,l}$	$C_{p,l}$	$C_{p,l}$	$C_{p,l}$	$C_{p,l}$	$C_{p,l}$	$C_{p,l}$	$C_{p,l}$	$C_{p,l}$
-0.400	0.1575	0.1576	0.2031	*****	*****	-0.6404	*****	*****	*****	*****
-0.600	0.1502	0.1651	0.1742	0.0134	0.0134	-0.7110	*****	*****	*****	*****
-0.700	0.1653	0.1678	0.1674	0.0485	0.0485	-0.6861	*****	*****	*****	*****
-0.800	0.1858	0.1647	0.1679	0.0652	0.0652	-0.6584	*****	*****	*****	*****
-0.850	0.2151	*****	0.1671	0.0883	-0.5900	*****	*****	*****	*****	*****
-0.900	*****	0.2043	0.1779	0.0971	-0.5910	*****	*****	*****	*****	*****
-0.950	*****	0.2276	0.1992	0.1217	-0.5744	*****	*****	*****	*****	*****
-0.975	*****	0.2380	0.2224	0.1641	-0.2047	*****	*****	*****	*****	*****
-1.000	*****	0.2000	0.1986	0.1644	-0.0585	*****	*****	*****	*****	*****
	-0.6434	-0.9049	-1.1461	-1.1368	-0.9080	*****	*****	*****	*****	*****

Medium Radius L.E.
 Run No. = 20 , Point No. = 397
 $C_N = 0.349$, $C_m = -0.0628$
 $\alpha = 8.2^\circ$, $M_\infty = 0.854$
 $R_{mac} = 85.0 \times 10^6$

Leading Edge Pressures

● starboard
 ○ port

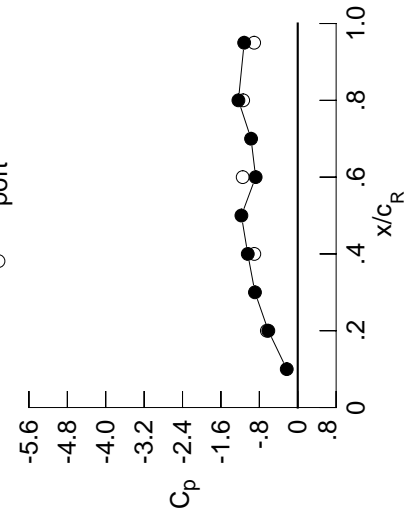

x/c_R	starb'd C_p	port C_p
0.10	-0.2288	*****
0.20	-0.6130	-0.6434
0.30	-0.8912	*****
0.40	-1.0409	-0.9049
0.50	-1.1737	*****
0.60	-0.8767	-1.1461
0.70	-0.9724	*****
0.80	-1.2357	-1.1368
0.90	*****	*****
0.95	-1.1158	-0.9080

Surface Pressures

● upper, starboard
 ○ lower, port

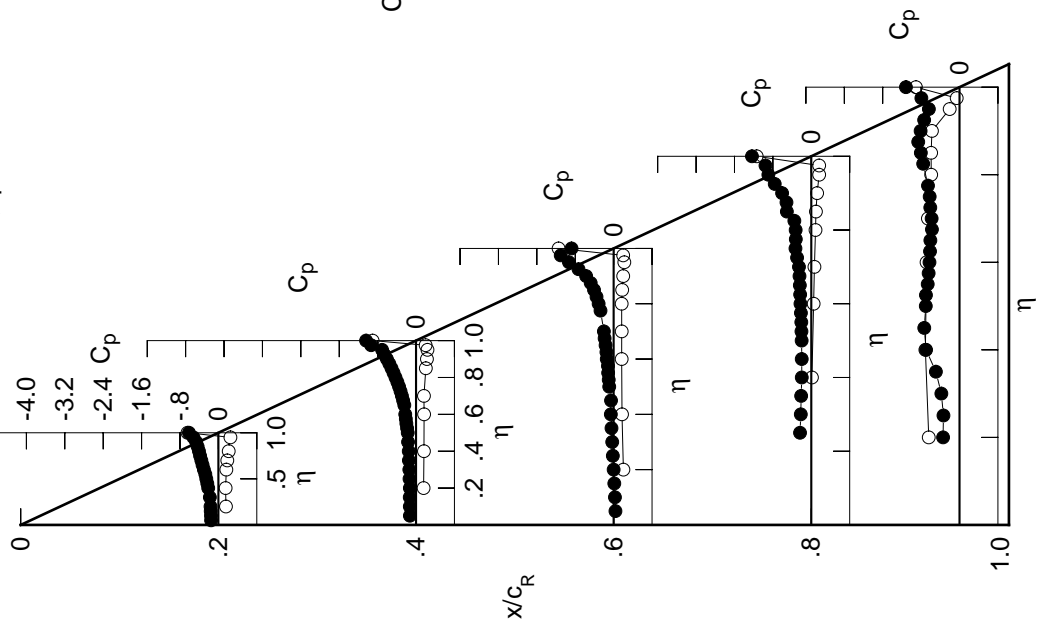

Table E8. Continued.

η	$x/c_R = .2$		$x/c_R = .4$		$x/c_R = .6$		$x/c_R = .8$		$x/c_R = .95$	
	$C_{p,u}$	$C_{p,u}$	$C_{p,u}$	$C_{p,u}$	$C_{p,u}$	$C_{p,u}$	$C_{p,u}$	$C_{p,u}$	$C_{p,u}$	$C_{p,u}$
0.050	-0.1676	-0.1470	0.0200	0.0200	0.0200	0.0200	0.0200	0.0200	0.0200	0.0200
0.100	-0.1723	-0.1500	0.0094	0.0094	0.0094	0.0094	0.0094	0.0094	0.0094	0.0094
0.150	-0.1797	-0.1517	-0.0051	-0.0051	-0.0051	-0.0051	-0.0051	-0.0051	-0.0051	-0.0051
0.200	-0.1839	-0.1501	-0.0203	-0.0203	-0.0203	-0.0203	-0.0203	-0.0203	-0.0203	-0.0203
0.250	*****	-0.1581	-0.0380	-0.0380	-0.0380	-0.0380	-0.0380	-0.0380	-0.0380	-0.0380
0.300	-0.1987	-0.1619	-0.0493	-0.0493	-0.0493	-0.0493	-0.0493	-0.0493	-0.0493	-0.0493
0.350	*****	-0.1712	-0.0645	-0.0645	-0.0645	-0.0645	-0.0645	-0.0645	-0.0645	-0.0645
0.400	-0.2355	-0.1757	-0.0773	-0.0773	-0.0773	-0.0773	-0.0773	-0.0773	-0.0773	-0.0773
0.450	-0.2552	-0.1917	-0.0846	-0.0846	-0.0846	-0.0846	-0.0846	-0.0846	-0.0846	-0.0846
0.500	-0.2785	-0.2039	-0.1283	-0.1283	-0.1283	-0.1283	-0.1283	-0.1283	-0.1283	-0.1283
0.525	*****	-0.2216	-0.1410	-0.1410	-0.1410	-0.1410	-0.1410	-0.1410	-0.1410	-0.1410
0.550	-0.3021	-0.2404	-0.1564	-0.1564	-0.1564	-0.1564	-0.1564	-0.1564	-0.1564	-0.1564
0.575	*****	-0.2523	-0.1645	-0.1645	-0.1645	-0.1645	-0.1645	-0.1645	-0.1645	-0.1645
0.600	-0.3353	-0.2661	-0.1916	-0.1916	-0.1916	-0.1916	-0.1916	-0.1916	-0.1916	-0.1916
0.625	*****	*****	-0.1919	-0.1919	-0.1919	-0.1919	-0.1919	-0.1919	-0.1919	-0.1919
0.650	-0.3675	-0.2842	-0.2000	-0.2000	-0.2000	-0.2000	-0.2000	-0.2000	-0.2000	-0.2000
0.675	*****	-0.3064	-0.2136	-0.2136	-0.2136	-0.2136	-0.2136	-0.2136	-0.2136	-0.2136
0.700	-0.3989	-0.3306	-0.2285	-0.2285	-0.2285	-0.2285	-0.2285	-0.2285	-0.2285	-0.2285
0.725	*****	-0.3606	*****	-0.2404	-0.2404	-0.2404	-0.2404	-0.2404	-0.2404	-0.2404
0.750	-0.4323	-0.3930	*****	-0.3635	-0.3635	-0.3635	-0.3635	-0.3635	-0.3635	-0.3635
0.775	*****	-0.4295	-0.3100	-0.6282	-0.6282	-0.6282	-0.6282	-0.6282	-0.6282	-0.6282
0.800	-0.4627	-0.4713	-0.4374	-0.7896	-0.7896	-0.7896	-0.7896	-0.7896	-0.7896	-0.7896
0.825	*****	-0.5158	-0.4898	-0.8321	-0.8321	-0.8321	-0.8321	-0.8321	-0.8321	-0.8321
0.850	-0.4979	-0.5621	-0.6053	-0.7687	-0.7687	-0.7687	-0.7687	-0.7687	-0.7687	-0.7687
0.875	*****	-0.6079	-0.8472	-0.6410	-0.7081	-0.7081	-0.7081	-0.7081	-0.7081	-0.7081
0.900	-0.5452	-0.6720	-0.9245	-0.6087	-0.6785	-0.6785	-0.6785	-0.6785	-0.6785	-0.6785
0.925	*****	-0.7513	-0.9677	-0.7376	-0.6313	-0.6313	-0.6313	-0.6313	-0.6313	-0.6313
0.950	-0.6235	-0.9799	-0.8931	-0.8295	-0.5409	-0.5409	-0.5409	-0.5409	-0.5409	-0.5409
0.975	*****	-1.2582	-1.0518	-0.7619	-0.6396	-0.6396	-0.6396	-0.6396	-0.6396	-0.6396
1.000	-0.8013	-1.1834	-0.9281	-1.2737	-0.9221	-0.9221	-0.9221	-0.9221	-0.9221	-0.9221
-0.200	$C_{p,l}$	$C_{p,l}$	$C_{p,l}$	$C_{p,l}$	$C_{p,l}$	$C_{p,l}$	$C_{p,l}$	$C_{p,l}$	$C_{p,l}$	$C_{p,l}$
-0.400	0.1835	0.1811	0.2201	0.2201	0.2201	0.2201	0.2201	0.2201	0.2201	0.2201
-0.600	0.1781	0.1884	0.1920	0.0297	-0.7059	-0.7059	-0.7059	-0.7059	-0.7059	-0.7059
-0.700	0.1947	0.1931	0.1859	0.0632	-0.6800	-0.6800	-0.6800	-0.6800	-0.6800	-0.6800
-0.800	0.2153	0.1917	0.1883	0.0813	-0.6514	-0.6514	-0.6514	-0.6514	-0.6514	-0.6514
-0.850	0.2424	*****	0.1891	0.1051	-0.5804	-0.5804	-0.5804	-0.5804	-0.5804	-0.5804
-0.900	*****	0.2308	0.2001	0.1155	-0.5804	-0.5804	-0.5804	-0.5804	-0.5804	-0.5804
-0.950	0.2517	0.2451	0.2289	0.1745	-0.5569	-0.5569	-0.5569	-0.5569	-0.5569	-0.5569
-0.975	*****	0.1861	0.1879	0.1601	-0.0556	-0.0556	-0.0556	-0.0556	-0.0556	-0.0556
-1.000	-0.8480	-1.0354	-1.2349	-1.2218	-0.9017	-0.9017	-0.9017	-0.9017	-0.9017	-0.9017

Medium Radius L.E.

Run No. = 20 , Point No. = 398

$C_N = 0.401$, $C_m = -0.0713$

$\alpha = 9.2^\circ$, $M_\infty = 0.850$

$R_{mac} = 85.0 \times 10^6$

Leading Edge Pressures

● starboard
○ port

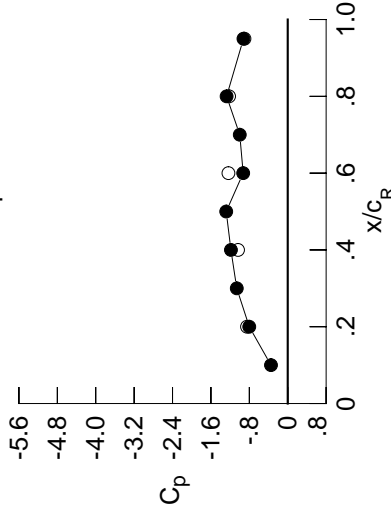

x/c_R	starb'd C_p	port C_p
0.10	-0.3489	*****
0.20	-0.8013	-0.8480
0.30	-1.0618	*****
0.40	-1.1834	-1.0354
0.50	-1.2817	*****
0.60	-0.9281	-1.2349
0.70	-0.9991	*****
0.80	-1.2737	-1.2218
0.90	*****	*****
0.95	-0.9221	-0.9017

Surface Pressures

● upper, starboard
○ lower, port

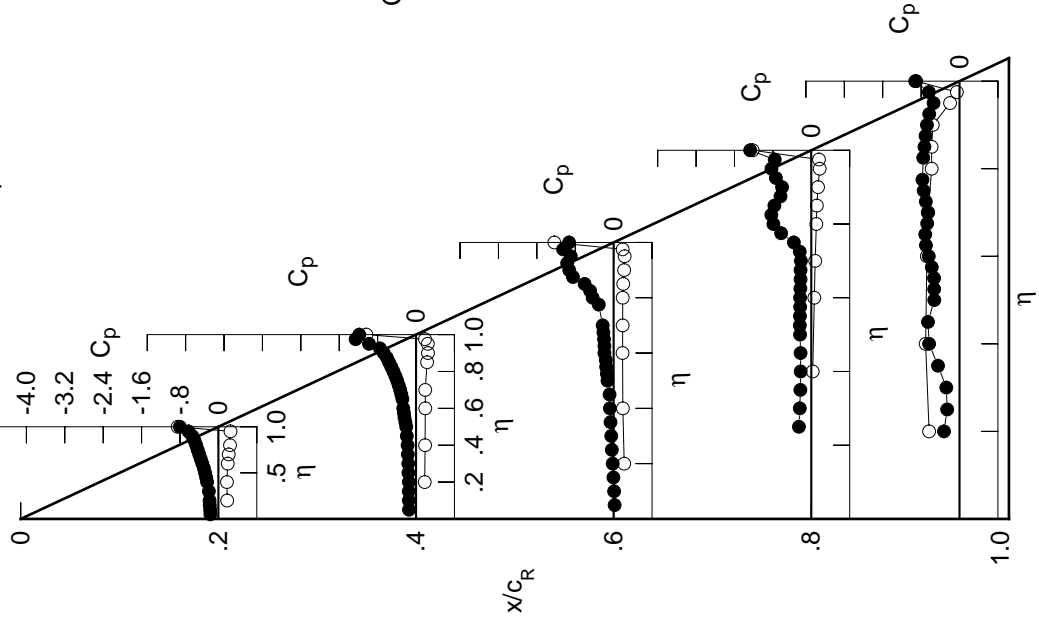
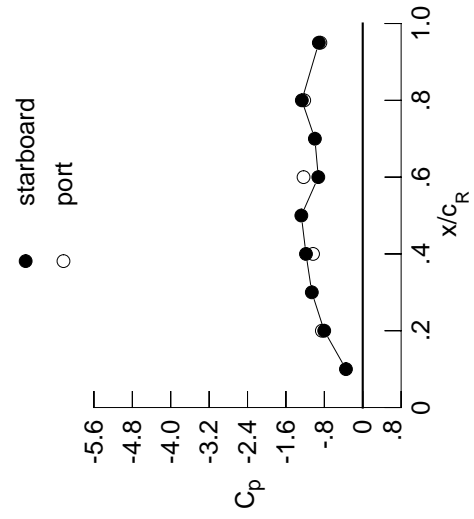

Table E8. Continued.

η	$x/c_R = .2$		$x/c_R = .4$		$x/c_R = .6$		$x/c_R = .8$		$x/c_R = .95$	
	$C_{p,u}$	$C_{p,u}$	$C_{p,u}$	$C_{p,u}$	$C_{p,u}$	$C_{p,u}$	$C_{p,u}$	$C_{p,u}$	$C_{p,u}$	$C_{p,u}$
0.050	-0.1676	-0.1474	0.0192	*****	*****	*****	*****	*****	*****	
0.100	-0.1724	-0.1505	0.0094	*****	*****	*****	*****	*****	*****	
0.150	-0.1797	-0.1525	-0.0063	*****	*****	*****	*****	*****	*****	
0.200	-0.1834	-0.1508	-0.0204	*****	*****	*****	*****	*****	-0.3239	
0.250	*****	-0.1588	-0.0385	-0.2594	-0.2537	*****	*****	*****	-0.2537	
0.300	-0.1986	-0.1627	-0.0500	-0.2412	-0.2771	*****	*****	*****	-0.2771	
0.350	*****	-0.1723	-0.0641	-0.2297	-0.4511	*****	*****	*****	-0.4511	
0.400	-0.2356	-0.1772	-0.0788	-0.2227	-0.6286	*****	*****	*****	-0.6286	
0.450	-0.2553	-0.1925	-0.0854	-0.2255	-0.6163	*****	*****	*****	-0.6163	
0.500	-0.2787	-0.2052	-0.1288	-0.2356	-0.4777	*****	*****	*****	-0.4777	
0.525	*****	-0.2228	-0.1411	-0.2408	-0.4967	*****	*****	*****	-0.4967	
0.550	-0.3023	-0.2416	-0.1567	-0.2361	-0.5259	*****	*****	*****	-0.5259	
0.575	*****	-0.2535	-0.1655	-0.2307	-0.5910	*****	*****	*****	-0.5910	
0.600	-0.3358	-0.2663	-0.1925	-0.2302	-0.6550	*****	*****	*****	-0.6550	
0.625	*****	*****	-0.1923	-0.2242	-0.7081	*****	*****	*****	-0.7081	
0.650	-0.3679	-0.2849	-0.1987	-0.2202	-0.7222	*****	*****	*****	-0.7222	
0.675	*****	-0.3071	-0.2124	-0.2211	-0.6894	*****	*****	*****	-0.6894	
0.700	-0.3992	-0.3321	-0.2244	-0.2154	-0.6919	*****	*****	*****	-0.6919	
0.725	*****	-0.3609	*****	-0.2470	-0.7365	*****	*****	*****	-0.7365	
0.750	-0.4333	-0.3942	*****	-0.3884	-0.7751	*****	*****	*****	-0.7751	
0.775	*****	-0.4308	-0.3082	-0.6589	-0.7978	*****	*****	*****	-0.7978	
0.800	-0.4636	-0.4734	-0.4488	-0.8031	*****	*****	*****	*****	-0.8031	
0.825	*****	-0.5177	-0.5140	-0.8343	-0.7722	*****	*****	*****	-0.7722	
0.850	-0.5007	-0.5635	-0.6374	-0.7716	-0.7385	*****	*****	*****	-0.7385	
0.875	*****	-0.6100	-0.8611	-0.6489	-0.7083	*****	*****	*****	-0.7083	
0.900	-0.5463	-0.6726	-0.9248	-0.6175	-0.6775	*****	*****	*****	-0.6775	
0.925	*****	-0.7567	-0.9629	-0.7412	-0.6312	*****	*****	*****	-0.6312	
0.950	-0.6266	-0.9927	-0.8895	-0.8160	-0.5425	*****	*****	*****	-0.5425	
0.975	*****	-1.2600	-1.0402	-0.7519	-0.6347	*****	*****	*****	-0.6347	
1.000	-0.8022	-1.1822	-0.9254	-1.2690	-0.9146	*****	*****	*****	-0.9146	
-0.200	$C_{p,l}$	0.1837	0.1820	0.2206	*****	*****	*****	*****	-0.6325	
-0.400	$C_{p,l}$	0.1787	0.1890	0.1936	0.0299	-0.7056	*****	*****	-0.7056	
-0.600	$C_{p,l}$	0.1957	0.1940	0.1867	0.0634	-0.6787	*****	*****	-0.6787	
-0.700	$C_{p,l}$	0.2163	0.1922	0.1892	0.0822	-0.6507	*****	*****	-0.6507	
-0.800	$C_{p,l}$	0.2432	*****	0.1897	0.1058	-0.5795	*****	*****	-0.5795	
-0.850	$C_{p,l}$	*****	0.2317	0.2009	0.1163	-0.5792	*****	*****	-0.5792	
-0.900	$C_{p,l}$	*****	0.2497	0.2193	0.1415	-0.5557	*****	*****	-0.5557	
-0.950	$C_{p,l}$	0.2522	0.2456	0.2295	0.1755	-0.1955	*****	*****	-0.1955	
-0.975	$C_{p,l}$	*****	0.1862	0.1881	0.1607	-0.0541	*****	*****	-0.0541	
-1.000	$C_{p,l}$	-0.8511	-1.0349	-1.2331	-1.2192	-0.8821	*****	*****	-0.8821	

Medium Radius L.E.
 Run No. = 20 , Point No. = 399
 $C_N = 0.403$, $C_m = -0.0718$
 $\alpha = 9.2^\circ$, $M_\infty = 0.851$
 $R_{mac} = 85.1 \times 10^6$

Leading Edge Pressures



x/c_R	starb'd C_p	port C_p
0.10	-0.3495	*****
0.20	-0.8022	-0.8511
0.30	-1.0610	*****
0.40	-1.1822	-1.0349
0.50	-1.2794	*****
0.60	-0.9254	-1.2331
0.70	-0.9971	*****
0.80	-1.2690	-1.2192
0.90	*****	*****
0.95	-0.9146	-0.8821

Surface Pressures

● upper, starboard
 ○ lower, port

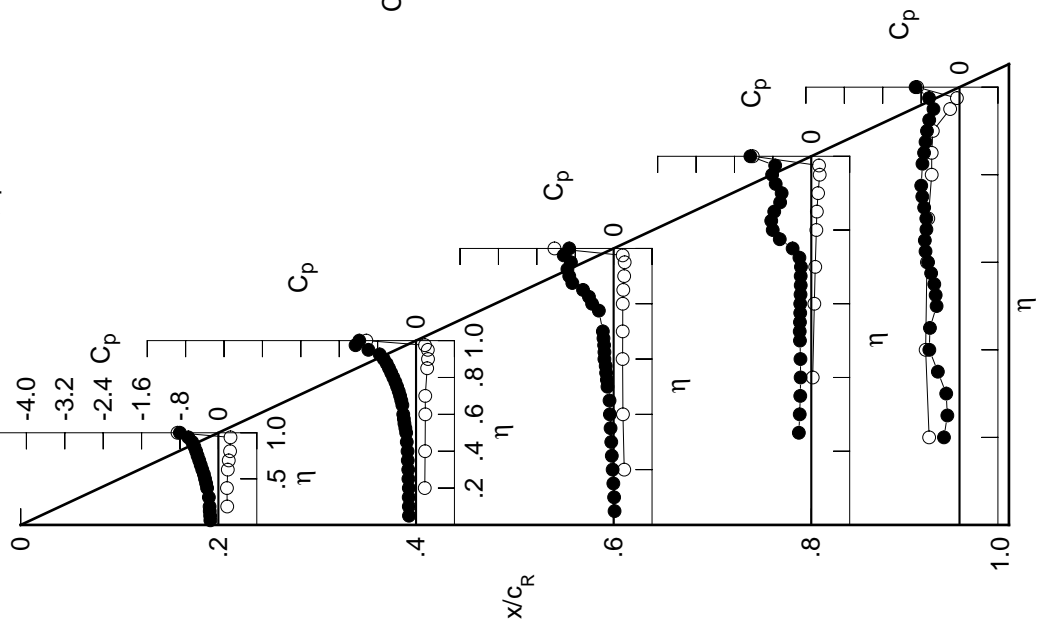
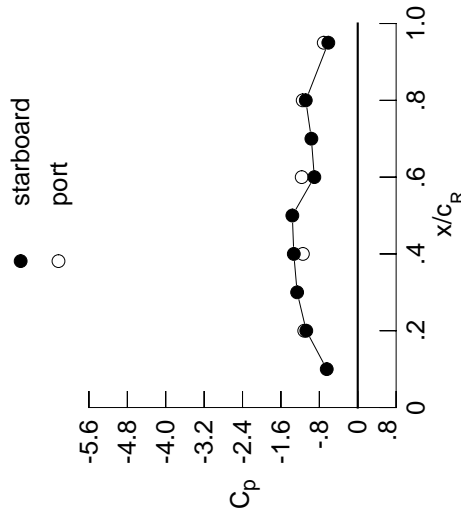

Table E8. Continued.

η	$x/c_R = .2$		$x/c_R = .4$		$x/c_R = .6$		$x/c_R = .8$		$x/c_R = .95$	
	$C_{p,u}$	$C_{p,l}$	$C_{p,u}$	$C_{p,l}$	$C_{p,u}$	$C_{p,l}$	$C_{p,u}$	$C_{p,l}$	$C_{p,u}$	$C_{p,l}$
0.050	-0.2011	-0.2072	-0.0294	*****	*****	*****	*****	*****	*****	*****
0.100	-0.2079	-0.2104	-0.0416	*****	*****	*****	*****	*****	*****	*****
0.150	-0.2217	-0.2129	-0.0584	*****	*****	*****	*****	*****	*****	*****
0.200	-0.2274	-0.2136	-0.0684	*****	*****	*****	*****	*****	*****	*****
0.250	*****	-0.2186	-0.0864	-0.3162	-0.2986	*****	*****	*****	*****	*****
0.300	-0.2473	-0.2225	-0.1045	-0.3006	-0.4045	*****	*****	*****	*****	*****
0.350	*****	-0.2445	-0.1286	-0.2961	-0.4331	*****	*****	*****	*****	*****
0.400	-0.2876	-0.2591	-0.1523	-0.2964	-0.4433	*****	*****	*****	*****	*****
0.450	-0.3114	-0.2849	-0.1684	-0.2804	-0.5394	*****	*****	*****	*****	*****
0.500	-0.3393	-0.2957	-0.1949	-0.2656	-0.7179	*****	*****	*****	*****	*****
0.525	*****	-0.3055	-0.1907	-0.2614	-0.7359	*****	*****	*****	*****	*****
0.550	-0.3689	-0.3186	-0.1882	-0.2527	-0.7221	*****	*****	*****	*****	*****
0.575	*****	-0.3241	-0.1756	-0.2496	-0.7217	*****	*****	*****	*****	*****
0.600	-0.4071	-0.3396	-0.1872	-0.2547	-0.7160	*****	*****	*****	*****	*****
0.625	*****	*****	-0.1779	-0.2741	-0.7435	*****	*****	*****	*****	*****
0.650	-0.4485	-0.4030	-0.1980	-0.3509	-0.8402	*****	*****	*****	*****	*****
0.675	*****	-0.4235	-0.2909	-0.5269	-0.9627	*****	*****	*****	*****	*****
0.700	-0.4912	-0.4292	-0.5012	-0.7671	-1.0891	*****	*****	*****	*****	*****
0.725	*****	-0.4404	*****	-0.9739	-1.1509	*****	*****	*****	*****	*****
0.750	-0.5481	-0.4528	*****	-1.0620	-1.1281	*****	*****	*****	*****	*****
0.775	*****	-0.4742	-0.9786	-1.0912	-0.9742	*****	*****	*****	*****	*****
0.800	-0.5887	-0.6200	-0.9510	-1.0318	*****	*****	*****	*****	*****	*****
0.825	*****	-0.9828	-0.9397	-0.9731	-0.6788	*****	*****	*****	*****	*****
0.850	-0.6361	-1.1131	-0.9494	-0.8667	-0.5955	*****	*****	*****	*****	*****
0.875	*****	-1.1519	-0.9804	-0.8073	-0.5559	*****	*****	*****	*****	*****
0.900	-0.6972	-1.1425	-0.9663	-0.7845	-0.5349	*****	*****	*****	*****	*****
0.925	*****	-1.1838	-0.9125	-0.7363	-0.5263	*****	*****	*****	*****	*****
0.950	-1.0573	-1.1987	-0.8625	-0.6910	-0.4770	*****	*****	*****	*****	*****
0.975	*****	-1.1699	-0.8225	-0.6348	-0.4432	*****	*****	*****	*****	*****
1.000	-1.0722	-1.3319	-0.9040	-1.0822	-0.6131	*****	*****	*****	*****	*****
-0.200	$C_{p,l}$	0.2428	0.2322	0.2585	*****	-0.6144	*****	*****	*****	*****
-0.400	$C_{p,l}$	0.2398	0.2412	0.2322	0.0612	-0.6852	*****	*****	*****	*****
-0.600	$C_{p,l}$	0.2587	0.2473	0.2278	0.0945	-0.6598	*****	*****	*****	*****
-0.700	$C_{p,l}$	0.2784	0.2488	0.2322	0.1134	-0.6298	*****	*****	*****	*****
-0.800	$C_{p,l}$	0.2979	*****	0.2352	0.1377	-0.5575	*****	*****	*****	*****
-0.850	$C_{p,l}$	*****	0.2832	0.2461	0.1490	-0.5532	*****	*****	*****	*****
-0.900	$C_{p,l}$	*****	0.2899	0.2588	0.1709	-0.5204	*****	*****	*****	*****
-0.950	$C_{p,l}$	0.2497	0.2592	0.2489	0.1886	-0.1785	*****	*****	*****	*****
-0.975	$C_{p,l}$	*****	0.1643	0.1837	0.1528	-0.0510	*****	*****	*****	*****
-1.000	$C_{p,l}$	-1.1146	-1.1424	-1.1671	-1.1461	-0.7078	*****	*****	*****	*****

Medium Radius L.E.
 Run No. = 20 , Point No. = 400
 $C_N = 0.532$, $C_m = -0.0935$
 $\alpha = 11.4^\circ$, $M_\infty = 0.852$
 $R_{mac} = 85.0 \times 10^6$

Leading Edge Pressures



x/c_R	starb'd C_p	port C_p
0.10	-0.6454	*****
0.20	-1.0722	-1.1146
0.30	-1.2626	*****
0.40	-1.3319	-1.1424
0.50	-1.3623	*****
0.60	-0.9040	-1.1671
0.70	-0.9660	*****
0.80	-1.0822	-1.1461
0.90	*****	*****
0.95	-0.6131	-0.7078

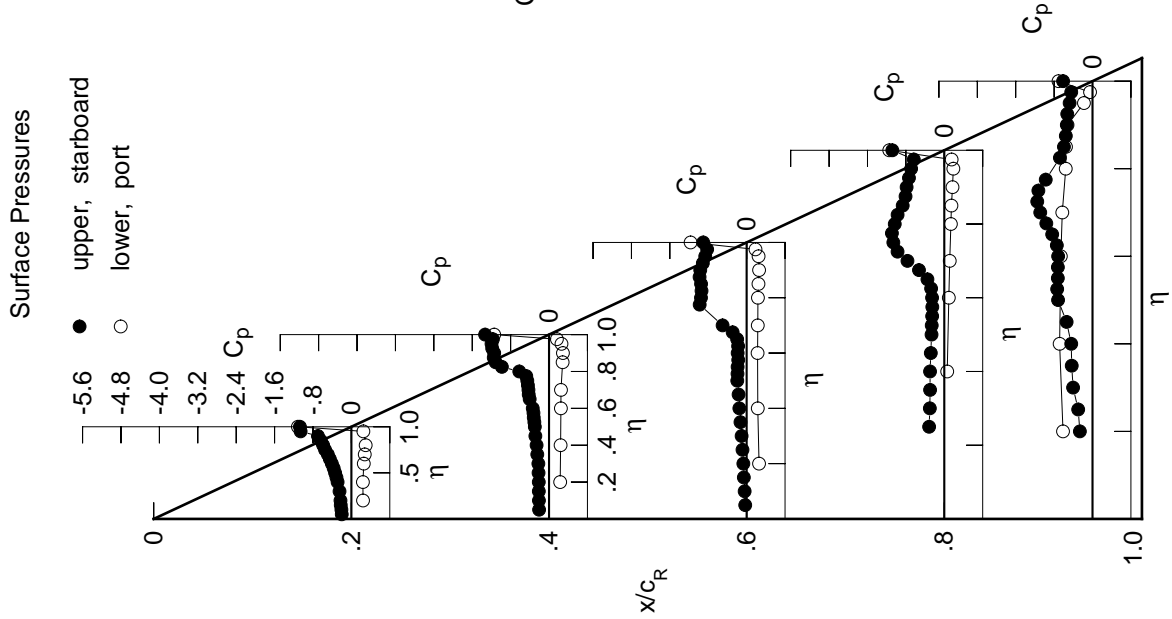

Table E8. Continued.

η	x/c_R .2	x/c_R .4	x/c_R .6	x/c_R .8	x/c_R .95
	$C_{p,u}$	$C_{p,u}$	$C_{p,u}$	$C_{p,u}$	$C_{p,u}$
0.050	-0.2213	-0.2426	-0.0532	*****	*****
0.100	-0.2254	-0.2434	-0.0638	*****	*****
0.150	-0.2442	-0.2471	-0.0814	*****	*****
0.200	-0.2530	-0.2462	-0.0897	*****	-0.3264
0.250	*****	-0.2513	-0.1120	-0.3449	-0.3430
0.300	-0.2764	-0.2645	-0.1320	-0.3354	-0.3955
0.350	*****	-0.2891	-0.1687	-0.3295	-0.3944
0.400	-0.3217	-0.3064	-0.1684	-0.3050	-0.5155
0.450	-0.3460	-0.3213	-0.1460	-0.2932	-0.7037
0.500	-0.3711	-0.3394	-0.1670	-0.2786	-0.6998
0.525	*****	-0.3355	-0.1649	-0.2756	-0.6878
0.550	-0.3990	-0.3372	-0.1617	-0.2731	-0.6723
0.575	*****	-0.3335	-0.1513	-0.2850	-0.6825
0.600	-0.4403	-0.3295	-0.2247	-0.3252	-0.7144
0.625	*****	*****	-0.3291	-0.4125	-0.8015
0.650	-0.4848	-0.2988	-0.5783	-0.5861	-0.9575
0.675	*****	-0.3370	-0.8184	-0.8264	-1.1134
0.700	-0.5381	-0.5649	-0.9573	-1.0426	-1.2545
0.725	*****	-0.8560	*****	-1.1945	-1.0884
0.750	-0.5849	-1.0233	*****	-1.2452	-0.8897
0.775	*****	-1.1109	-1.1248	-1.1927	-0.7898
0.800	-0.6294	-1.1422	-1.0726	-1.0739	*****
0.825	*****	-1.1409	-1.0480	-0.9615	-0.5836
0.850	-0.7220	-1.1511	-1.0078	-0.8497	-0.5261
0.875	*****	-1.1558	-0.9720	-0.8201	-0.5317
0.900	-0.9890	-1.0868	-0.9211	-0.7894	-0.5352
0.925	*****	-1.0766	-0.8663	-0.7154	-0.5593
0.950	-1.2581	-1.1421	-0.8243	-0.6849	-0.5180
0.975	*****	-1.0814	-0.7932	-0.6369	-0.4669
1.000	-1.1697	-1.3498	-0.8711	-0.9930	-0.6099
	$C_{p,l}$	$C_{p,l}$	$C_{p,l}$	$C_{p,l}$	$C_{p,l}$
-0.200	0.2731	0.2574	0.2765	*****	-0.6029
-0.400	0.2709	0.2660	0.2505	0.0768	-0.6742
-0.600	0.2903	0.2729	0.2474	0.1098	-0.6494
-0.700	0.3080	0.2749	0.2519	0.1294	-0.6190
-0.800	0.3239	*****	0.2546	0.1531	-0.5457
-0.850	*****	0.3047	0.2642	0.1639	-0.5394
-0.900	*****	0.3052	0.2729	0.1839	-0.5017
-0.950	0.2465	0.2593	0.2502	0.1921	-0.1695
-0.975	*****	0.1460	0.1698	0.1425	-0.0492
-1.000	-1.1746	-1.1769	-1.0844	-1.0645	-0.6160

Medium Radius L.E.
 Run No. = 20, Point No. = 401
 $C_N = 0.594$, $C_m = -0.1032$
 $\alpha = 12.4^\circ$, $M_\infty = 0.852$
 $R_{mac} = 84.8 \times 10^6$

Leading Edge Pressures

● starboard
 ○ port

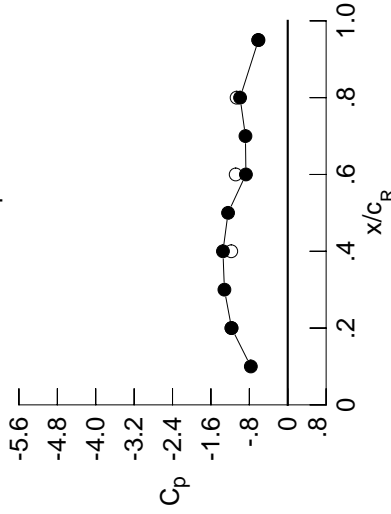

x/c_R	starb'd C_p	port C_p
0.10	-0.7692	*****
0.20	-1.1697	-1.1746
0.30	-1.3192	*****
0.40	-1.3498	-1.1769
0.50	-1.2430	*****
0.60	-0.8711	-1.0844
0.70	-0.8810	*****
0.80	-0.9930	-1.0645
0.90	*****	*****
0.95	-0.6099	-0.6160

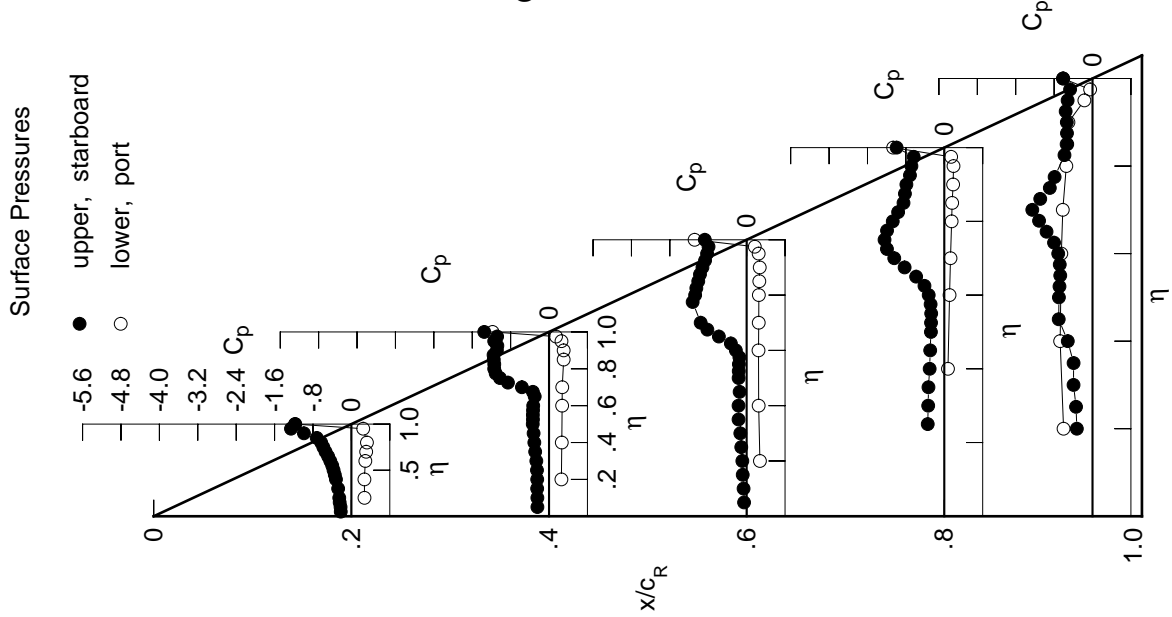
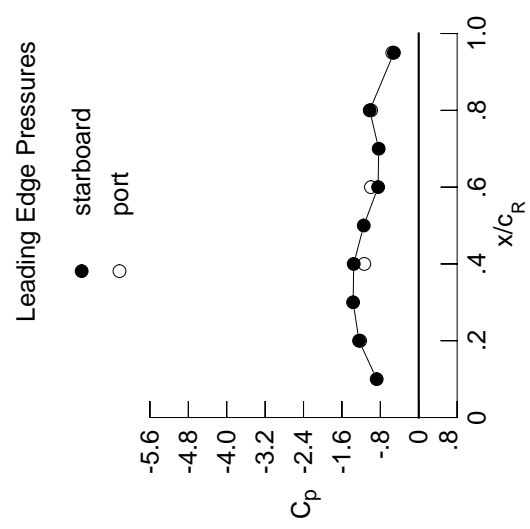

Table E8. Continued.

η	$x/c_R = .2$		$x/c_R = .4$		$x/c_R = .6$		$x/c_R = .8$		$x/c_R = .95$	
	$C_{p,u}$	$C_{p,u}$	$C_{p,u}$	$C_{p,u}$	$C_{p,u}$	$C_{p,u}$	$C_{p,u}$	$C_{p,u}$	$C_{p,u}$	$C_{p,u}$
0.050	-0.2481	-0.2839	-0.0768	*****	*****	*****	*****	*****	*****	*****
0.100	-0.2491	-0.2853	-0.0875	*****	*****	*****	*****	*****	*****	*****
0.150	-0.2679	-0.2855	-0.1021	*****	*****	*****	*****	*****	*****	*****
0.200	-0.2813	-0.2838	-0.1150	*****	*****	*****	*****	*****	*****	-0.3647
0.250	*****	-0.2922	-0.1359	-0.3713	-0.3601	-0.4256	*****	*****	*****	-0.3631
0.300	-0.3189	-0.3128	-0.1593	-0.3601	-0.3601	-0.4256	*****	*****	*****	-0.4256
0.350	*****	-0.3388	-0.1998	-0.3554	-0.3554	-0.4642	*****	*****	*****	-0.4642
0.400	-0.3611	-0.3506	-0.2065	-0.3388	-0.3388	-0.5447	*****	*****	*****	-0.5447
0.450	-0.3791	-0.3879	-0.1916	-0.3265	-0.3265	-0.6639	*****	*****	*****	-0.6639
0.500	-0.4038	-0.4095	-0.2066	-0.3159	-0.3159	-0.6899	*****	*****	*****	-0.6899
0.525	*****	-0.3998	-0.2074	-0.3191	-0.3191	-0.6909	*****	*****	*****	-0.6909
0.550	-0.4341	-0.4027	-0.2127	-0.3300	-0.3300	-0.6973	*****	*****	*****	-0.6973
0.575	*****	-0.4034	-0.2173	-0.3639	-0.3639	-0.7381	*****	*****	*****	-0.7381
0.600	-0.4779	-0.3971	-0.3094	-0.4376	-0.4376	-0.8075	*****	*****	*****	-0.8075
0.625	*****	*****	-0.4358	-0.5652	-0.5652	-0.9266	*****	*****	*****	-0.9266
0.650	-0.5182	-0.3788	-0.7017	-0.7616	-0.7616	-1.0899	*****	*****	*****	-1.0899
0.675	*****	-0.4514	-0.9794	-0.9906	-0.9906	-1.1884	*****	*****	*****	-1.1884
0.700	-0.5656	-0.7125	-1.1629	-1.1888	-1.1888	-0.8030	*****	*****	*****	-0.8030
0.725	*****	-1.0429	*****	-1.3333	-0.7652	*****	*****	*****	*****	-0.7652
0.750	-0.6149	-1.2294	*****	-1.3670	-0.6930	*****	*****	*****	*****	-0.6930
0.775	*****	-1.2979	-1.2482	-1.1058	-0.6205	*****	*****	*****	*****	-0.6205
0.800	-0.7890	-1.2862	-1.1901	-0.9914	*****	*****	*****	*****	*****	-0.9914
0.825	*****	-1.2721	-1.1268	-0.8846	-0.5701	*****	*****	*****	*****	-0.5701
0.850	-1.0813	-1.2651	-1.0617	-0.8458	-0.5349	*****	*****	*****	*****	-0.5349
0.875	*****	-1.2451	-0.9889	-0.8424	-0.5464	*****	*****	*****	*****	-0.5464
0.900	-1.2347	-1.1600	-0.9300	-0.8083	-0.5494	*****	*****	*****	*****	-0.5494
0.925	*****	-1.1152	-0.8779	-0.7366	-0.5557	*****	*****	*****	*****	-0.5557
0.950	-1.3083	-1.1690	-0.8281	-0.7692	-0.4874	*****	*****	*****	*****	-0.4874
0.975	*****	-1.1101	-0.7948	-0.6996	-0.4244	*****	*****	*****	*****	-0.4244
1.000	-1.2435	-1.3545	-0.8458	-1.0212	-0.5172	*****	*****	*****	*****	-0.5172
-0.200	$C_{p,l}$	$C_{p,l}$	$C_{p,l}$	$C_{p,l}$	$C_{p,l}$	$C_{p,l}$	$C_{p,l}$	$C_{p,l}$	$C_{p,l}$	$C_{p,l}$
-0.400	0.3045	0.2828	0.2949	*****	*****	-0.5920	*****	*****	*****	-0.5920
-0.600	0.3023	0.2919	0.2689	0.0926	-0.6634	*****	*****	*****	*****	-0.6634
-0.700	0.3216	0.2977	0.2664	0.1249	-0.6394	*****	*****	*****	*****	-0.6394
-0.800	0.3380	0.3003	0.2708	0.1438	-0.6078	*****	*****	*****	*****	-0.6078
-0.850	0.3490	*****	0.2733	0.1678	-0.5338	*****	*****	*****	*****	-0.5338
-0.900	*****	0.3250	0.2813	0.1780	-0.5245	*****	*****	*****	*****	-0.5245
-0.950	*****	0.3198	0.2866	0.1957	-0.4833	*****	*****	*****	*****	-0.4833
-0.975	0.2445	0.2610	0.2511	0.1942	-0.1607	*****	*****	*****	*****	-0.1607
-1.000	0.2445	0.1340	0.1573	0.1319	-0.0495	*****	*****	*****	*****	-0.0495
-1.000	-1.2202	-1.1343	-0.9949	-0.9909	-0.5508	*****	*****	*****	*****	-0.5508

Medium Radius L.E.
 Run No. = 20 , Point No. = 402
 $C_N = 0.654$, $C_m = -0.1106$
 $\alpha = 13.5^\circ$, $M_\infty = 0.853$
 $R_{mac} = 84.9 \times 10^6$



x/c_R	starb'd C_p	port C_p
0.10	-0.8761	*****
0.20	-1.2435	-1.2202
0.30	-1.3671	*****
0.40	-1.3545	-1.1343
0.50	-1.1456	*****
0.60	-0.8458	-0.9949
0.70	-0.8341	*****
0.80	-1.0212	-0.9909
0.90	*****	*****
0.95	-0.5172	-0.5508

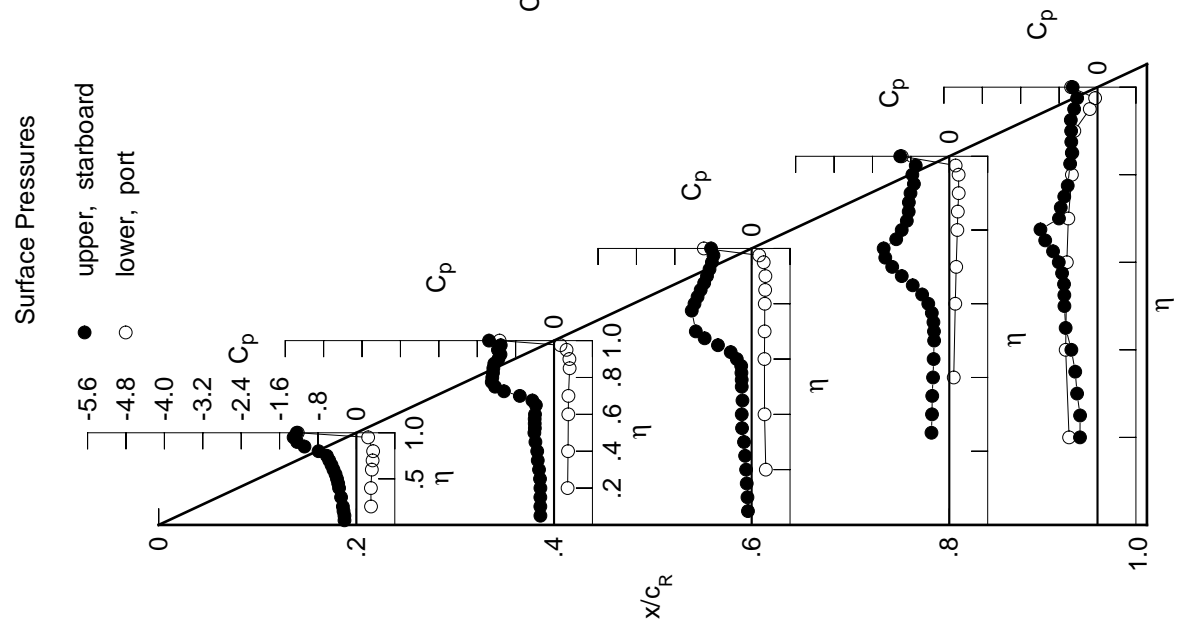
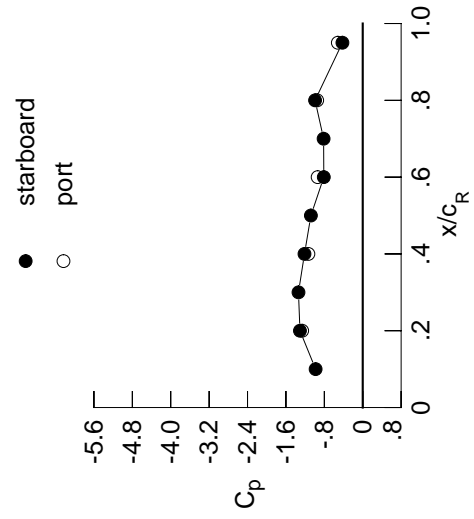

Table E8. Continued.

η	$x/c_R = .2$		$x/c_R = .4$		$x/c_R = .6$		$x/c_R = .8$		$x/c_R = .95$	
	$C_{p,u}$	$C_{p,u}$	$C_{p,u}$	$C_{p,u}$	$C_{p,u}$	$C_{p,u}$	$C_{p,u}$	$C_{p,u}$	$C_{p,u}$	$C_{p,u}$
0.050	-0.2737	-0.3229	-0.0982	*****	*****	*****	*****	*****	*****	*****
0.100	-0.2710	-0.3251	-0.1100	*****	*****	*****	*****	*****	*****	*****
0.150	-0.2873	-0.3224	-0.1252	*****	*****	*****	*****	*****	*****	*****
0.200	-0.3016	-0.3220	-0.1381	*****	*****	*****	*****	*****	*****	*****
0.250	*****	-0.3421	-0.1729	-0.4009	-0.4709	*****	*****	*****	*****	-0.5116
0.300	-0.3659	-0.3708	-0.1797	-0.3886	-0.4331	*****	*****	*****	*****	*****
0.350	*****	-0.3637	-0.1867	-0.3709	-0.5226	*****	*****	*****	*****	*****
0.400	-0.3886	-0.3557	-0.1930	-0.3538	-0.6950	*****	*****	*****	*****	*****
0.450	-0.4034	-0.3552	-0.1735	-0.3468	-0.7095	*****	*****	*****	*****	*****
0.500	-0.4252	-0.3403	-0.2222	-0.3529	-0.7081	*****	*****	*****	*****	*****
0.525	*****	-0.3414	-0.2480	-0.3755	-0.7283	*****	*****	*****	*****	*****
0.550	-0.4536	-0.3477	-0.3056	-0.4195	-0.7680	*****	*****	*****	*****	*****
0.575	*****	-0.3734	-0.3980	-0.5055	-0.8530	*****	*****	*****	*****	*****
0.600	-0.4871	-0.4760	-0.6337	-0.6387	-0.9581	*****	*****	*****	*****	*****
0.625	*****	*****	-0.8665	-0.8171	-1.0879	*****	*****	*****	*****	*****
0.650	-0.5242	-1.0426	-1.1058	-1.0210	-0.9985	*****	*****	*****	*****	*****
0.675	*****	-1.2503	-1.2885	-1.2105	-0.7224	*****	*****	*****	*****	*****
0.700	-0.5962	-1.3391	-1.3767	-1.3510	-0.6823	*****	*****	*****	*****	*****
0.725	*****	-1.3189	*****	-1.1914	-0.6110	*****	*****	*****	*****	*****
0.750	-0.9049	-1.2616	*****	-1.0655	-0.5450	*****	*****	*****	*****	*****
0.775	*****	-1.2292	-1.2436	-1.0609	-0.5119	*****	*****	*****	*****	*****
0.800	-1.1376	-1.1606	-1.2079	-1.0685	*****	*****	*****	*****	*****	*****
0.825	*****	-1.1461	-1.1082	-1.0007	-0.5032	*****	*****	*****	*****	*****
0.850	-1.2819	-1.1648	-1.0092	-0.9439	-0.4833	*****	*****	*****	*****	*****
0.875	*****	-1.1707	-0.9671	-0.8771	-0.5062	*****	*****	*****	*****	*****
0.900	-1.2970	-1.1070	-0.9190	-0.8041	-0.5224	*****	*****	*****	*****	*****
0.925	*****	-1.0772	-0.8549	-0.7673	-0.5139	*****	*****	*****	*****	*****
0.950	-1.2971	-1.1067	-0.8011	-0.8020	-0.4386	*****	*****	*****	*****	*****
0.975	*****	-1.0411	-0.7709	-0.7247	-0.3677	*****	*****	*****	*****	*****
1.000	-1.3077	-1.2135	-0.8110	-0.9931	-0.4232	*****	*****	*****	*****	*****
-0.200	$C_{p,l}$	$C_{p,l}$	$C_{p,l}$	$C_{p,l}$	$C_{p,l}$	$C_{p,l}$	$C_{p,l}$	$C_{p,l}$	$C_{p,l}$	$C_{p,l}$
-0.400	0.3337	0.3073	0.3127	*****	-0.5792	*****	*****	*****	*****	*****
-0.600	0.3331	0.3154	0.2876	0.1077	-0.6547	*****	*****	*****	*****	*****
-0.700	0.3517	0.3221	0.2851	0.1403	-0.6306	*****	*****	*****	*****	*****
-0.800	0.3657	0.3247	0.2897	0.1596	-0.5991	*****	*****	*****	*****	*****
-0.850	0.3720	*****	0.2912	0.1823	-0.5227	*****	*****	*****	*****	*****
-0.900	*****	0.3436	0.2976	0.1917	-0.5113	*****	*****	*****	*****	*****
-0.950	*****	0.3313	0.2974	0.2069	-0.4667	*****	*****	*****	*****	*****
-0.975	0.2397	0.2587	0.2489	0.1948	-0.1538	*****	*****	*****	*****	*****
-1.000	*****	0.1147	0.1405	0.1189	-0.0526	*****	*****	*****	*****	*****
	-1.2619	-1.1317	-0.9395	-0.9489	-0.5183	*****	*****	*****	*****	*****

Medium Radius L.E.
 Run No. = 20 , Point No. = 403
 $C_N = 0.710$, $C_m = -0.1157$
 $\alpha = 14.6^\circ$, $M_\infty = 0.851$
 $R_{mac} = 84.7 \times 10^6$

Leading Edge Pressures



x/c_R	starb'd C_p	port C_p
0.10	-0.9816	*****
0.20	-1.3077	-1.2619
0.30	-1.3386	*****
0.40	-1.2135	-1.1317
0.50	-1.0797	*****
0.60	-0.8110	-0.9395
0.70	-0.8149	*****
0.80	-0.9931	-0.9489
0.90	*****	*****
0.95	-0.4232	-0.5183

Surface Pressures

● upper, starboard
 ○ lower, port

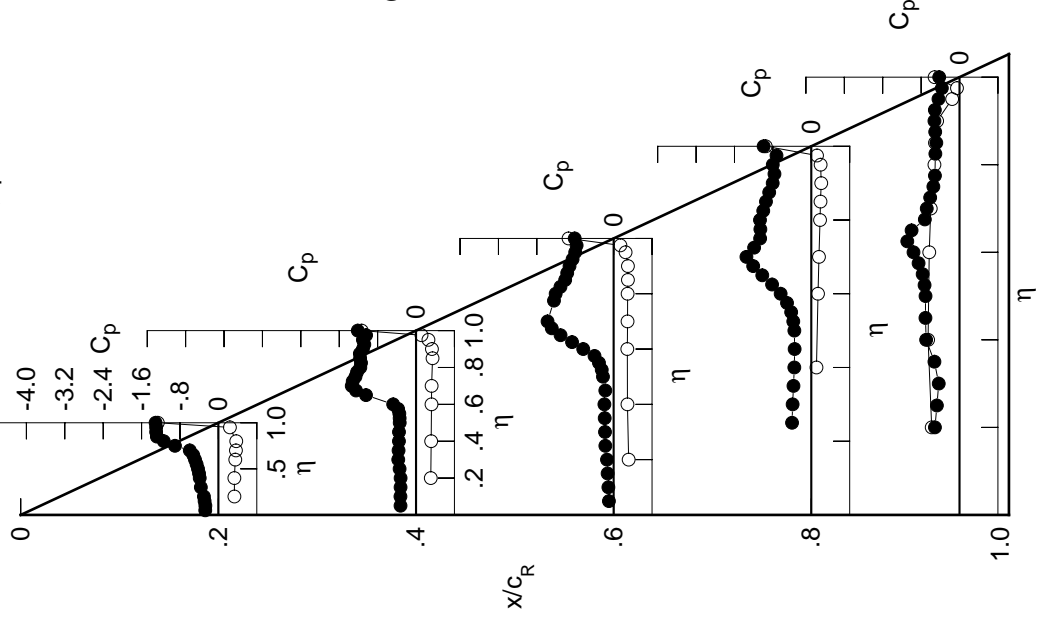
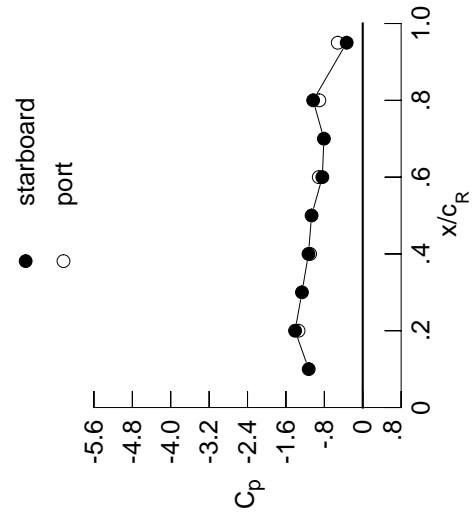

Table E8. Continued.

η	$x/c_R = .2$		$x/c_R = .4$		$x/c_R = .6$		$x/c_R = .8$		$x/c_R = .95$	
	$C_{p,u}$	$C_{p,u}$	$C_{p,u}$	$C_{p,u}$	$C_{p,u}$	$C_{p,u}$	$C_{p,u}$	$C_{p,u}$	$C_{p,u}$	$C_{p,u}$
0.050	-0.3284	-0.3940	-0.1232	*****	*****	*****	*****	*****	*****	*****
0.100	-0.3205	-0.3919	-0.1355	*****	*****	*****	*****	*****	*****	*****
0.150	-0.3341	-0.3897	-0.1470	*****	*****	*****	*****	*****	*****	*****
0.200	-0.3539	-0.3871	-0.1635	*****	*****	*****	*****	*****	*****	*****
0.250	*****	-0.4098	-0.1902	-0.4534	-0.5623	*****	*****	*****	*****	*****
0.300	-0.4295	-0.4190	-0.2047	-0.4371	-0.6059	*****	*****	*****	*****	*****
0.350	*****	-0.4199	-0.2148	-0.4275	-0.6133	*****	*****	*****	*****	*****
0.400	-0.4235	-0.4113	-0.2293	-0.4178	-0.6583	*****	*****	*****	*****	*****
0.450	-0.4543	-0.4146	-0.2392	-0.4367	-0.6885	*****	*****	*****	*****	*****
0.500	-0.5181	-0.4370	-0.3761	-0.5060	-0.7393	*****	*****	*****	*****	*****
0.525	*****	-0.5029	-0.4902	-0.5817	-0.7932	*****	*****	*****	*****	*****
0.550	-0.5320	-0.6234	-0.6506	-0.6896	-0.8571	*****	*****	*****	*****	*****
0.575	*****	-0.8234	-0.8315	-0.8349	-0.9630	*****	*****	*****	*****	*****
0.600	-0.5749	-1.0517	-1.0686	-0.9939	-1.0547	*****	*****	*****	*****	*****
0.625	*****	*****	-1.2363	-1.1513	-0.7148	*****	*****	*****	*****	*****
0.650	-0.8715	-1.4320	-1.3755	-1.2970	-0.5611	*****	*****	*****	*****	*****
0.675	*****	-1.5280	-1.4887	-1.1269	-0.4716	*****	*****	*****	*****	*****
0.700	-1.1943	-1.5749	-1.5430	-0.9941	-0.4408	*****	*****	*****	*****	*****
0.725	*****	-1.5410	*****	-0.9776	-0.4355	*****	*****	*****	*****	*****
0.750	-1.2592	-1.4317	*****	-0.9718	-0.4321	*****	*****	*****	*****	*****
0.775	*****	-1.3756	-1.1927	-1.0018	-0.4401	*****	*****	*****	*****	*****
0.800	-1.3502	-1.3032	-1.1075	-1.0554	*****	*****	*****	*****	*****	*****
0.825	*****	-1.2419	-1.0600	-1.0416	-0.4579	*****	*****	*****	*****	*****
0.850	-1.3862	-1.1998	-1.0308	-1.0360	-0.4509	*****	*****	*****	*****	*****
0.875	*****	-1.1661	-1.0364	-0.9282	-0.4552	*****	*****	*****	*****	*****
0.900	-1.3421	-1.1310	-1.0008	-0.8568	-0.4418	*****	*****	*****	*****	*****
0.925	*****	-1.0935	-0.9278	-0.8734	-0.4076	*****	*****	*****	*****	*****
0.950	-1.2712	-1.0638	-0.8976	-0.9193	-0.3499	*****	*****	*****	*****	*****
0.975	*****	-1.0081	-0.8660	-0.8355	-0.3011	*****	*****	*****	*****	*****
1.000	-1.4096	-1.1306	-0.8419	-1.0328	-0.3347	*****	*****	*****	*****	*****
-0.200	$C_{p,l}$	$C_{p,l}$	$C_{p,l}$	$C_{p,l}$	$C_{p,l}$	$C_{p,l}$	$C_{p,l}$	$C_{p,l}$	$C_{p,l}$	$C_{p,l}$
-0.400	0.3968	0.3591	0.3511	*****	*****	*****	*****	*****	*****	*****
-0.600	0.3966	0.3666	0.3269	0.1400	-0.6362	*****	*****	*****	*****	*****
-0.700	0.4134	0.3726	0.3238	0.1722	-0.6121	*****	*****	*****	*****	*****
-0.800	0.4220	0.3737	0.3285	0.1905	-0.5782	*****	*****	*****	*****	*****
-0.850	0.4177	*****	0.3269	0.2129	-0.4987	*****	*****	*****	*****	*****
-0.900	*****	0.3801	0.3289	0.2203	-0.4838	*****	*****	*****	*****	*****
-0.950	*****	0.3539	0.3176	0.2295	-0.4357	*****	*****	*****	*****	*****
-0.975	0.2323	0.2551	0.2427	0.1963	-0.1417	*****	*****	*****	*****	*****
-1.000	0.0820	0.0820	0.1060	0.0940	-0.0638	*****	*****	*****	*****	*****
-1.000	-1.3370	-1.0963	-0.9160	-0.9041	-0.5203	*****	*****	*****	*****	*****

Medium Radius L.E.
 Run No. = 20 , Point No. = 404
 $C_N = 0.801$, $C_m = -0.1185$
 $\alpha = 16.7^\circ$, $M_\infty = 0.850$
 $R_{mac} = 84.5 \times 10^6$

Leading Edge Pressures



x/c_R	starb'd C_p	port C_p
0.10	-1.1257	*****
0.20	-1.4096	-1.3370
0.30	-1.2660	*****
0.40	-1.1306	-1.0963
0.50	-1.0658	*****
0.60	-0.8419	-0.9160
0.70	-0.8088	*****
0.80	-1.0328	-0.9041
0.90	*****	*****
0.95	-0.3347	-0.5203

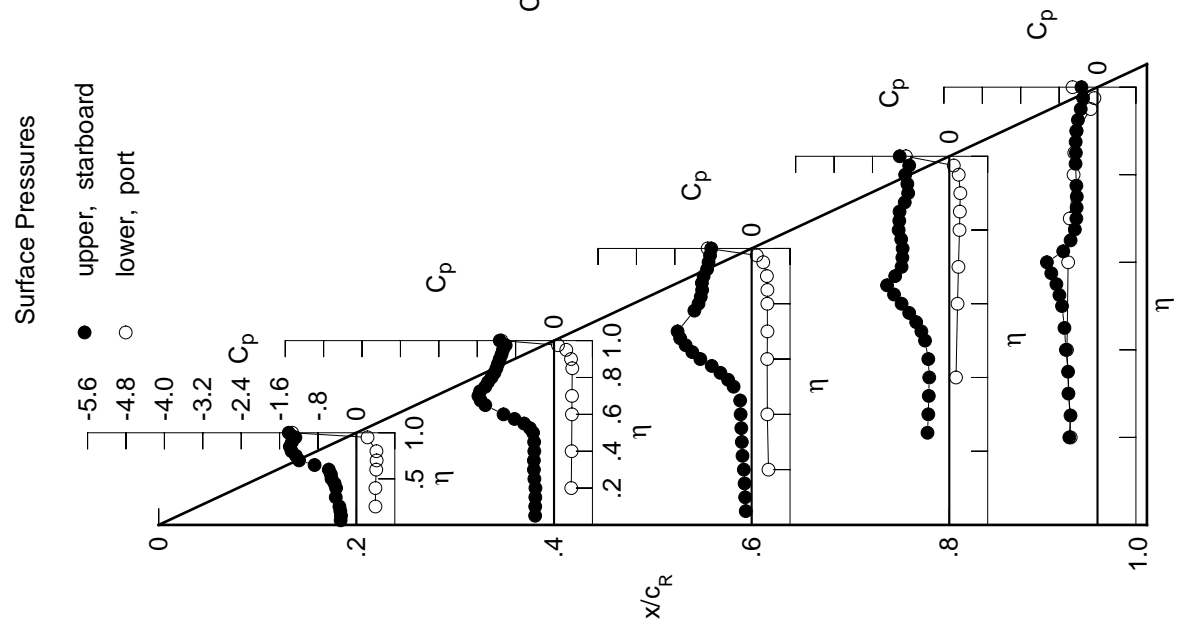

Table E8. Continued.

η	$x/c_R = .2$		$x/c_R = .4$		$x/c_R = .6$		$x/c_R = .8$		$x/c_R = .95$	
	$C_{p,u}$	$C_{p,u}$	$C_{p,u}$	$C_{p,u}$	$C_{p,u}$	$C_{p,u}$	$C_{p,u}$	$C_{p,u}$	$C_{p,u}$	$C_{p,u}$
0.050	-0.3974	-0.4621	-0.0976	*****	*****	*****	*****	*****	*****	*****
0.100	-0.3906	-0.4627	-0.1144	*****	*****	*****	*****	*****	*****	*****
0.150	-0.4013	-0.4553	-0.1302	*****	*****	*****	*****	*****	*****	*****
0.200	-0.4564	-0.4790	-0.1611	*****	*****	*****	*****	*****	*****	-0.6208
0.250	*****	-0.4767	-0.1780	-0.4355	-0.6312	*****	*****	*****	*****	-0.6312
0.300	-0.4429	-0.4768	-0.1954	-0.4341	-0.6551	*****	*****	*****	*****	-0.6551
0.350	*****	-0.4832	-0.2262	-0.4473	-0.6849	*****	*****	*****	*****	-0.6849
0.400	-0.4659	-0.4928	-0.2759	-0.4686	-0.7241	*****	*****	*****	*****	-0.7241
0.450	-0.4755	-0.5478	-0.3471	-0.5376	-0.7897	*****	*****	*****	*****	-0.7897
0.500	-0.4846	-0.6812	-0.5892	-0.6678	-0.8905	*****	*****	*****	*****	-0.8905
0.525	*****	-0.8239	-0.7505	-0.7654	-0.9662	*****	*****	*****	*****	-0.9662
0.550	-0.6553	-1.0213	-0.9238	-0.8811	-1.0383	*****	*****	*****	*****	-1.0383
0.575	*****	-1.2107	-1.0951	-1.0126	-1.0448	*****	*****	*****	*****	-1.0448
0.600	-1.2042	-1.3733	-1.2737	-1.1432	-0.7532	*****	*****	*****	*****	-0.7532
0.625	*****	*****	-1.3853	-1.2572	-0.6090	*****	*****	*****	*****	-0.6090
0.650	-1.4748	-1.6024	-1.4611	-1.0355	-0.5162	*****	*****	*****	*****	-0.5162
0.675	*****	-1.6630	-1.2370	-0.9302	-0.4848	*****	*****	*****	*****	-0.4848
0.700	-1.4584	-1.7065	-1.1851	-0.9170	-0.4847	*****	*****	*****	*****	-0.4847
0.725	*****	-1.6191	*****	-0.9234	-0.4880	*****	*****	*****	*****	-0.4880
0.750	-1.4388	-1.5063	*****	-0.9286	-0.4837	*****	*****	*****	*****	-0.4837
0.775	*****	-1.3959	-1.2026	-0.9533	-0.4813	*****	*****	*****	*****	-0.4813
0.800	-1.4666	-1.2918	-1.2696	-0.9825	*****	*****	*****	*****	*****	-0.9825
0.825	*****	-1.2288	-1.3201	-0.9474	-0.4693	*****	*****	*****	*****	-0.4693
0.850	-1.4247	-1.2010	-1.2350	-0.9454	-0.4478	*****	*****	*****	*****	-0.4478
0.875	*****	-1.2038	-1.0655	-0.9106	-0.4315	*****	*****	*****	*****	-0.4315
0.900	-1.2995	-1.1706	-0.9759	-0.9121	-0.4092	*****	*****	*****	*****	-0.4092
0.925	*****	-1.1221	-0.9755	-0.9296	-0.3852	*****	*****	*****	*****	-0.3852
0.950	-1.2086	-1.1028	-0.9776	-0.9464	-0.3553	*****	*****	*****	*****	-0.3553
0.975	*****	-1.0672	-0.9555	-0.8905	-0.3309	*****	*****	*****	*****	-0.3309
1.000	-1.4416	-1.1589	-0.9230	-1.0025	-0.3602	*****	*****	*****	*****	-0.3602
-0.200	$C_{p,l}$	$C_{p,l}$	$C_{p,l}$	$C_{p,l}$	$C_{p,l}$	$C_{p,l}$	$C_{p,l}$	$C_{p,l}$	$C_{p,l}$	$C_{p,l}$
-0.400	0.4531	0.4048	0.3849	*****	*****	*****	*****	*****	*****	-0.5686
-0.600	0.4541	0.4128	0.3623	0.1640	-0.6381	*****	*****	*****	*****	-0.6381
-0.700	0.4677	0.4167	0.3595	0.1967	-0.6118	*****	*****	*****	*****	-0.6118
-0.800	0.4705	0.4172	0.3643	0.2149	-0.5770	*****	*****	*****	*****	-0.5770
-0.850	0.4557	*****	0.3617	0.2373	-0.4995	*****	*****	*****	*****	-0.4995
-0.900	*****	0.4099	0.3602	0.2423	-0.4860	*****	*****	*****	*****	-0.4860
-0.950	*****	0.3707	0.3402	0.2482	-0.4398	*****	*****	*****	*****	-0.4398
-0.975	0.2227	0.2487	0.2461	0.2068	-0.1589	*****	*****	*****	*****	-0.1589
-1.000	*****	0.0510	0.0903	0.1000	-0.0949	*****	*****	*****	*****	-0.0949
-1.000	-1.3846	-1.0982	-0.8409	-0.7841	-0.5302	*****	*****	*****	*****	-0.5302

Medium Radius L.E.
 Run No. = 20 , Point No. = 405
 $C_N = 0.863$, $C_m = -0.1235$
 $\alpha = 18.7^\circ$, $M_\infty = 0.851$
 $R_{mac} = 84.6 \times 10^6$

Leading Edge Pressures

● starboard
 ○ port

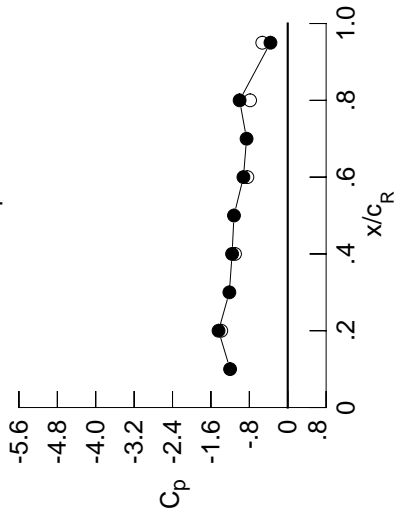

x/c_R	starb'd C_p	port C_p
0.10	-1.2012	*****
0.20	-1.4416	-1.3846
0.30	-1.2163	*****
0.40	-1.1589	-1.0982
0.50	-1.1202	*****
0.60	-0.9230	-0.8409
0.70	-0.8575	*****
0.80	-1.0025	-0.7841
0.90	*****	*****
0.95	-0.3602	-0.5302

Surface Pressures

● upper, starboard
 ○ lower, port

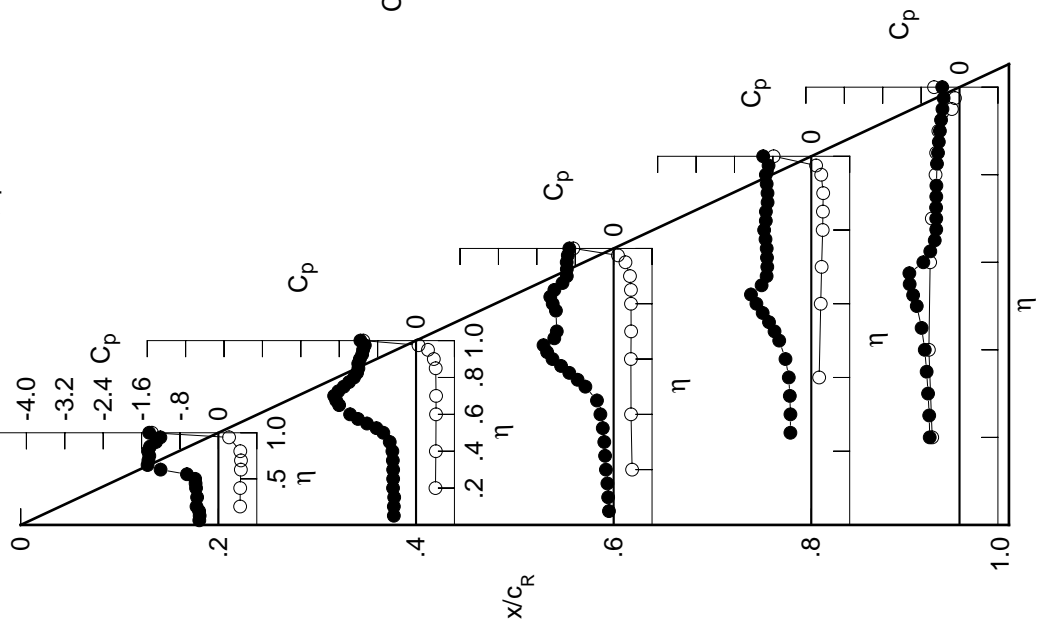
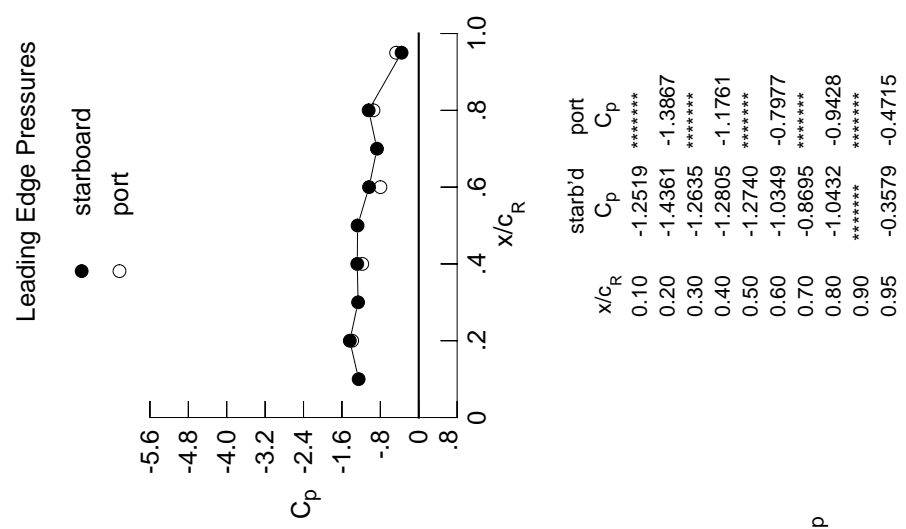

Table E8. Concluded.

η	x/c_R .2	x/c_R .4	x/c_R .6	x/c_R .8	x/c_R .95
	$C_{p,u}$	$C_{p,u}$	$C_{p,u}$	$C_{p,u}$	$C_{p,u}$
0.050	-0.4560	-0.5221	-0.0944	*****	*****
0.100	-0.4501	-0.5225	-0.1168	*****	*****
0.150	-0.4888	-0.5215	-0.1421	*****	*****
0.200	-0.4890	-0.5426	-0.1759	*****	-0.3299
0.250	*****	-0.5489	-0.2342	-0.5312	-0.4235
0.300	-0.4907	-0.5589	-0.2703	-0.5337	-0.5010
0.350	*****	-0.5896	-0.3431	-0.5619	-0.5378
0.400	-0.5139	-0.6555	-0.4600	-0.6197	-0.6258
0.450	-0.5425	-0.8141	-0.6248	-0.7331	-0.7307
0.500	-0.7055	-1.0322	-0.9229	-0.9065	-0.8827
0.525	*****	-1.1712	-1.0694	-1.0102	-0.9720
0.550	-1.1730	-1.3266	-1.2083	-1.1207	-0.9128
0.575	*****	-1.4370	-1.3304	-1.2336	-0.6900
0.600	-1.5730	-1.5324	-1.4501	-1.3365	-0.6228
0.625	*****	*****	-1.5003	-1.3888	-0.6068
0.650	-1.7392	-1.6823	-1.2415	-1.1143	-0.6019
0.675	*****	-1.5425	-1.2033	-1.0861	-0.5916
0.700	-1.5859	-1.4760	-1.1988	-1.0820	-0.5828
0.725	*****	-1.4641	*****	-1.0833	-0.5716
0.750	-1.4531	-1.4736	*****	-1.0822	-0.5451
0.775	*****	-1.4824	-1.2430	-1.1025	-0.5212
0.800	-1.4911	-1.4846	-1.3186	-1.1212	*****
0.825	*****	-1.4474	-1.3214	-1.0795	-0.5102
0.850	-1.4103	-1.3176	-1.2043	-1.0733	-0.4876
0.875	*****	-1.2157	-1.1059	-1.0072	-0.4843
0.900	-1.3021	-1.2018	-1.0735	-0.9750	-0.4728
0.925	*****	-1.2075	-1.0883	-0.9762	-0.4463
0.950	-1.2229	-1.2091	-1.1024	-0.9973	-0.4004
0.975	*****	-1.1867	-1.0994	-0.9675	-0.3658
1.000	-1.4361	-1.2805	-1.0349	-1.0432	-0.3579
	$C_{p,l}$	$C_{p,l}$	$C_{p,l}$	$C_{p,l}$	$C_{p,l}$
-0.200	0.5170	0.4590	0.4277	*****	-0.5325
-0.400	0.5180	0.4669	0.4053	0.2022	-0.6055
-0.600	0.5274	0.4672	0.4014	0.2316	-0.5793
-0.700	0.5238	0.4654	0.4046	0.2471	-0.5429
-0.800	0.4968	*****	0.3974	0.2653	-0.4628
-0.850	*****	0.4419	0.3896	0.2671	-0.4455
-0.900	*****	0.3874	0.3575	0.2629	-0.3955
-0.950	0.2156	0.2401	0.2372	0.1937	-0.1353
-0.975	*****	0.0175	0.0552	0.0527	-0.0933
-1.000	-1.3867	-1.1761	-0.7977	-0.9428	-0.4715

Medium Radius L.E.
 Run No. = 20 , Point No. = 406
 $C_N = 0.991$, $C_m = -0.1504$
 $\alpha = 20.9^\circ$, $M_\infty = 0.851$
 $R_{mac} = 84.2 \times 10^6$



x/c_R	starb'd C_p	port C_p
0.10	-1.2519	*****
0.20	-1.4361	-1.3867
0.30	-1.2635	*****
0.40	-1.2805	-1.1761
0.50	-1.2740	*****
0.60	-1.0349	-0.7977
0.70	-0.8695	*****
0.80	-1.0432	-0.9428
0.90	*****	*****
0.95	-0.3579	-0.4715

Table E9. Tabulations and Plots of Surface Pressure Coefficients.

η	x/c_R .2	x/c_R .4	x/c_R .6	x/c_R .8	x/c_R .95
	$C_{p,u}$	$C_{p,u}$	$C_{p,u}$	$C_{p,u}$	$C_{p,u}$
0.050	0.0015	0.0155	0.1405	0.1405	0.1405
0.100	0.0057	0.0161	0.1319	0.1319	0.1319
0.150	0.0017	0.0163	0.1185	0.1185	0.1185
0.200	0.0010	0.0215	0.1064	0.1064	0.1064
0.250	0.0000	0.0155	0.0930	0.0930	0.0930
0.300	-0.0081	0.0157	0.0840	0.0840	0.0840
0.350	0.0000	0.0126	0.0737	0.0737	0.0737
0.400	-0.0228	0.0139	0.0658	0.0658	0.0658
0.450	-0.0280	0.0097	0.0763	0.0763	0.0763
0.500	-0.0342	0.0114	0.0488	0.0691	0.0691
0.525	0.0000	0.0058	0.0466	0.0681	0.0681
0.550	-0.0336	0.0007	0.0439	0.0632	0.0632
0.575	0.0000	-0.0002	0.0498	0.0646	0.06579
0.600	-0.0402	-0.0036	0.0345	0.0637	0.06559
0.625	0.0000	0.0000	0.0364	0.0600	0.06612
0.650	-0.0395	-0.0048	0.0307	0.0582	0.06862
0.675	0.0000	-0.0176	0.0232	0.0606	0.06934
0.700	-0.0338	-0.0246	0.0221	0.0589	0.07152
0.725	0.0000	-0.0313	0.0000	0.0579	0.07271
0.750	-0.0243	-0.0379	0.0000	0.0571	0.07270
0.775	0.0000	-0.0416	0.0004	0.0635	0.07197
0.800	-0.0058	-0.0443	-0.0116	0.0674	0.06674
0.825	0.0000	-0.0424	-0.0228	0.0640	0.07048
0.850	0.0187	-0.0374	-0.0313	0.0848	0.06899
0.875	0.0000	-0.0272	-0.0364	0.0932	0.07434
0.900	0.0510	-0.0153	-0.0328	0.1011	0.07256
0.925	0.0000	0.0086	-0.0186	0.0928	0.09392
0.950	0.1017	0.0464	0.0120	0.0632	0.03852
0.975	0.0000	0.1040	0.0698	0.0035	0.02076
1.000	0.2241	0.2186	0.1950	0.1583	0.0805
	$C_{p,l}$	$C_{p,l}$	$C_{p,l}$	$C_{p,l}$	$C_{p,l}$
-0.200	-0.0247	-0.0026	0.0823	0.0823	0.0823
-0.400	-0.0514	-0.0006	0.0415	0.1023	0.06366
-0.600	-0.0745	-0.0269	0.0140	0.0818	0.06216
-0.700	-0.0778	-0.0635	-0.0089	0.0819	0.06357
-0.800	-0.0634	0.0000	-0.0580	0.0962	0.07229
-0.850	0.0000	-0.0970	-0.0897	0.1269	0.07417
-0.900	0.0000	-0.0848	-0.1061	0.1636	0.04928
-0.950	0.0360	-0.0363	-0.0755	0.1537	0.03904
-0.975	0.0000	0.0153	-0.0277	0.1014	0.02732
-1.000	0.1912	0.1860	0.1483	0.1384	0.0649

Medium Radius L.E.
 Run No. = 15 , Point No. = 313
 $C_N = -0.028$, $C_m = 0.0043$
 $\alpha = -0.7^\circ$, $M_\infty = 0.850$
 $R_{mac} = 96.9 \times 10^6$

Surface Pressures
 ● upper, starboard
 ○ lower, port

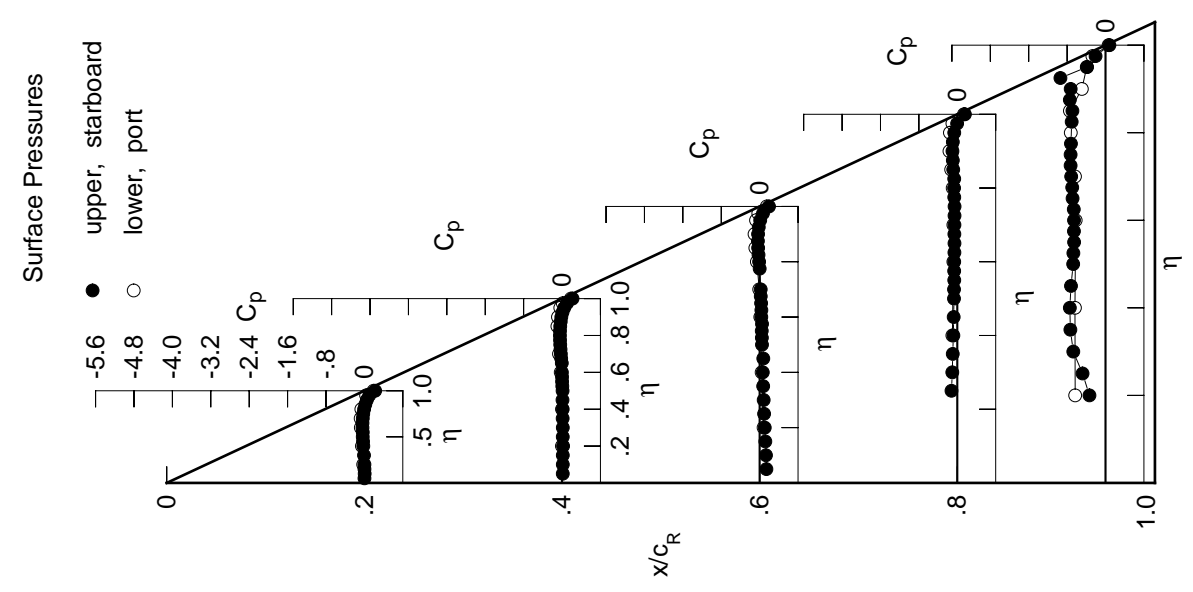

Leading Edge Pressures
 ● starboard
 ○ port

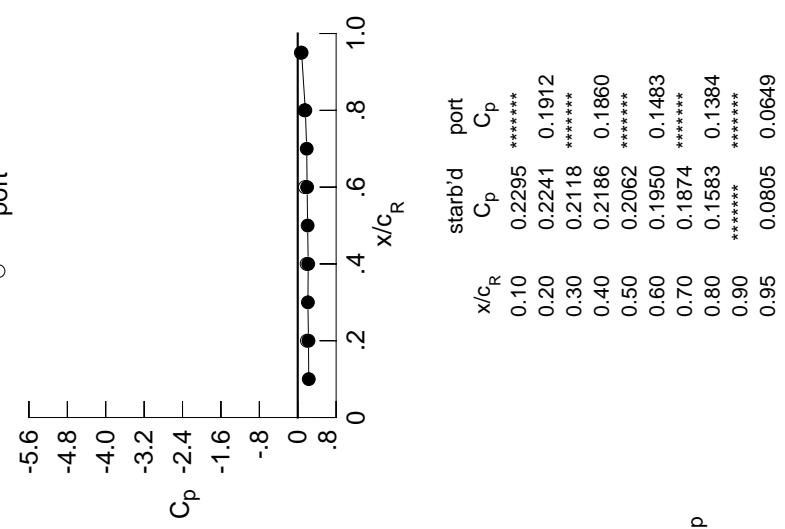

Table E9. Continued.

η	$x/c_R = .2$		$x/c_R = .4$		$x/c_R = .6$		$x/c_R = .8$		$x/c_R = .95$	
	$C_{p,u}$	$C_{p,u}$	$C_{p,u}$	$C_{p,u}$	$C_{p,u}$	$C_{p,u}$	$C_{p,u}$	$C_{p,u}$	$C_{p,u}$	$C_{p,u}$
0.050	-0.0055	0.0085	0.1358	*****	*****	*****	*****	*****	*****	
0.100	-0.0013	0.0094	0.1269	*****	*****	*****	*****	*****	*****	
0.150	-0.0054	0.0091	0.1133	*****	*****	*****	*****	*****	*****	
0.200	-0.0056	0.0148	0.1012	*****	*****	*****	*****	*****	-0.3405	
0.250	*****	0.0080	0.0874	-0.1244	-0.1244	-0.4776	-0.4776	-0.4776	-0.4776	
0.300	-0.0159	0.0085	0.0790	-0.1089	-0.1089	-0.6521	-0.6521	-0.6521	-0.6521	
0.350	*****	0.0057	0.0685	-0.0995	-0.0995	-0.7106	-0.7106	-0.7106	-0.7106	
0.400	-0.0312	0.0066	0.0602	-0.0877	-0.0877	-0.7103	-0.7103	-0.7103	-0.7103	
0.450	-0.0370	0.0019	0.0697	-0.0807	-0.0807	-0.6688	-0.6688	-0.6688	-0.6688	
0.500	-0.0438	0.0036	0.0426	-0.0745	-0.0745	-0.6143	-0.6143	-0.6143	-0.6143	
0.525	*****	-0.0024	0.0401	-0.0738	-0.0738	-0.6205	-0.6205	-0.6205	-0.6205	
0.550	-0.0437	-0.0082	0.0376	-0.0693	-0.0693	-0.6125	-0.6125	-0.6125	-0.6125	
0.575	*****	-0.0093	0.0435	-0.0709	-0.0709	-0.6268	-0.6268	-0.6268	-0.6268	
0.600	-0.0510	-0.0129	0.0271	-0.0695	-0.0695	-0.6353	-0.6353	-0.6353	-0.6353	
0.625	*****	*****	0.0292	-0.0668	-0.0668	-0.6543	-0.6543	-0.6543	-0.6543	
0.650	-0.0511	-0.0149	0.0231	-0.0651	-0.0651	-0.6903	-0.6903	-0.6903	-0.6903	
0.675	*****	-0.0285	0.0159	-0.0675	-0.0675	-0.7071	-0.7071	-0.7071	-0.7071	
0.700	-0.0461	-0.0355	0.0141	-0.0659	-0.0659	-0.7310	-0.7310	-0.7310	-0.7310	
0.725	*****	-0.0436	*****	-0.0654	-0.0654	-0.7370	-0.7370	-0.7370	-0.7370	
0.750	-0.0376	-0.0504	*****	-0.0647	-0.0647	-0.7330	-0.7330	-0.7330	-0.7330	
0.775	*****	-0.0554	-0.0098	-0.0718	-0.0718	-0.7243	-0.7243	-0.7243	-0.7243	
0.800	-0.0192	-0.0597	-0.0238	-0.0769	-0.0769	*****	*****	*****	*****	
0.825	*****	-0.0582	-0.0362	-0.0741	-0.0741	-0.7059	-0.7059	-0.7059	-0.7059	
0.850	0.0037	-0.0546	-0.0469	-0.0963	-0.0963	-0.6875	-0.6875	-0.6875	-0.6875	
0.875	*****	-0.0448	-0.0531	-0.1068	-0.1068	-0.7506	-0.7506	-0.7506	-0.7506	
0.900	0.0354	-0.0348	-0.0523	-0.1177	-0.1177	-0.6811	-0.6811	-0.6811	-0.6811	
0.925	*****	-0.0116	-0.0391	-0.1128	-0.1128	-0.8613	-0.8613	-0.8613	-0.8613	
0.950	0.0858	0.0252	-0.0111	-0.0855	-0.0855	-0.3974	-0.3974	-0.3974	-0.3974	
0.975	*****	0.0821	0.0453	-0.0277	-0.0277	-0.2259	-0.2259	-0.2259	-0.2259	
1.000	0.2266	0.2244	0.2107	0.1692	0.1692	0.0902	0.0902	0.0902	0.0902	
η	$C_{p,l}$	$C_{p,l}$	$C_{p,l}$	$C_{p,l}$	$C_{p,l}$	$C_{p,l}$	$C_{p,l}$	$C_{p,l}$	$C_{p,l}$	
-0.200	-0.0172	0.0049	0.0870	*****	*****	-0.6348	-0.6348	-0.6348	-0.6348	
-0.400	-0.0427	0.0062	0.0468	-0.0977	-0.0977	-0.6217	-0.6217	-0.6217	-0.6217	
-0.600	-0.0635	-0.0181	0.0210	-0.0772	-0.0772	-0.6783	-0.6783	-0.6783	-0.6783	
-0.700	-0.0645	-0.0530	-0.0012	-0.0759	-0.0759	-0.7106	-0.7106	-0.7106	-0.7106	
-0.800	-0.0485	*****	-0.0454	-0.0871	-0.0871	-0.7227	-0.7227	-0.7227	-0.7227	
-0.850	*****	-0.0801	-0.0744	-0.1137	-0.1137	-0.7503	-0.7503	-0.7503	-0.7503	
-0.900	*****	-0.0649	-0.0863	-0.1454	-0.1454	-0.5172	-0.5172	-0.5172	-0.5172	
-0.950	0.0551	-0.0130	-0.0500	-0.1284	-0.1284	-0.3765	-0.3765	-0.3765	-0.3765	
-0.975	*****	0.0415	0.0015	-0.0711	-0.0711	-0.2522	-0.2522	-0.2522	-0.2522	
-1.000	0.1967	0.1963	0.1639	0.1579	0.1579	0.0770	0.0770	0.0770	0.0770	

Medium Radius L.E.

Run No. = 15, Point No. = 314

$C_N = -0.012$, $C_m = 0.0011$

$\alpha = -0.4^\circ$, $M_\infty = 0.849$

$R_{mac} = 96.3 \times 10^6$

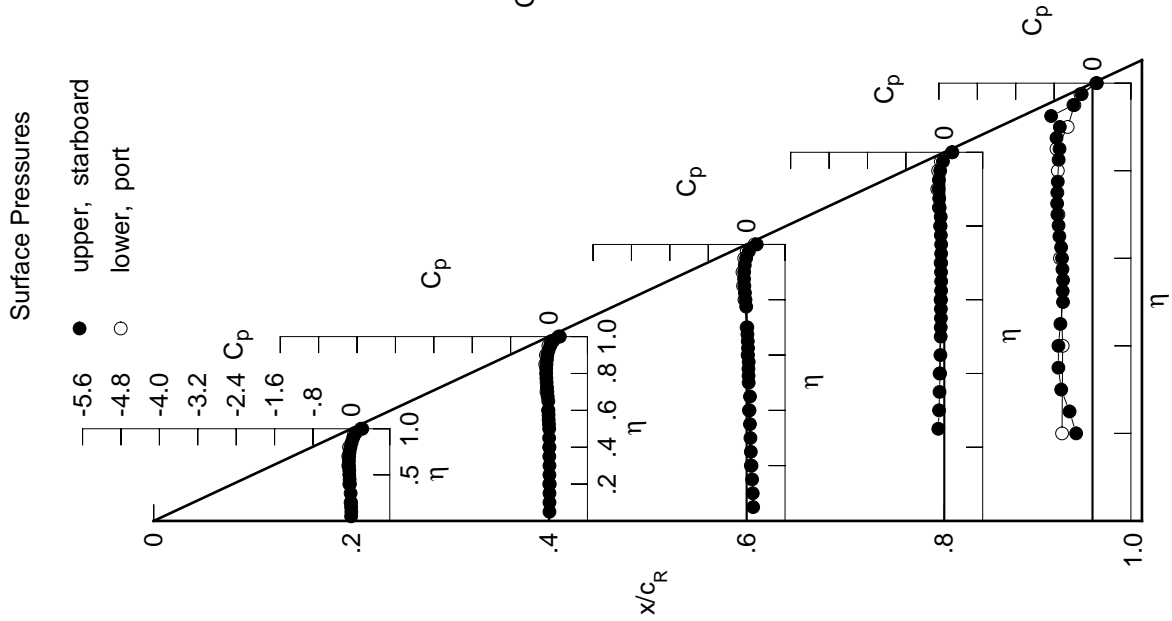

Leading Edge Pressures

- starboard
- port

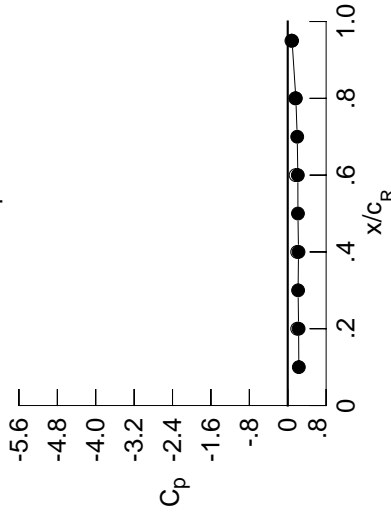

x/c_R	starb'd C_p	port C_p
0.10	0.2311	*****
0.20	0.2266	0.1967
0.30	0.2158	*****
0.40	0.2244	0.1963
0.50	0.2126	*****
0.60	0.2107	0.1639
0.70	0.1975	*****
0.80	0.1692	0.1579
0.90	*****	*****
0.95	0.0902	0.0770

Table E9. Continued.

η	$x/c_R = .2$		$x/c_R = .4$		$x/c_R = .6$		$x/c_R = .8$		$x/c_R = .95$	
	$C_{p,u}$	$C_{p,u}$	$C_{p,u}$	$C_{p,u}$	$C_{p,u}$	$C_{p,u}$	$C_{p,u}$	$C_{p,u}$	$C_{p,u}$	$C_{p,u}$
0.050	-0.0257	-0.0077	0.1236	*****	*****	*****	*****	*****	*****	*****
0.100	-0.0208	-0.0070	0.1145	*****	*****	*****	*****	*****	*****	*****
0.150	-0.0252	-0.0080	0.1008	*****	*****	*****	*****	*****	*****	*****
0.200	-0.0256	-0.0018	0.0891	*****	*****	*****	*****	*****	*****	-0.3174
0.250	*****	-0.0090	0.0746	-0.1358	-0.4397	*****	*****	*****	*****	-0.4397
0.300	-0.0352	-0.0084	0.0658	-0.1201	-0.6099	*****	*****	*****	*****	-0.6099
0.350	*****	-0.0125	0.0546	-0.1108	-0.6890	*****	*****	*****	*****	-0.6890
0.400	-0.0535	-0.0122	0.0459	-0.0994	-0.6901	*****	*****	*****	*****	-0.6901
0.450	-0.0611	-0.0172	0.0549	-0.0939	-0.6486	*****	*****	*****	*****	-0.6486
0.500	-0.0689	-0.0165	0.0267	-0.0873	-0.5877	*****	*****	*****	*****	-0.5877
0.525	*****	-0.0232	0.0238	-0.0874	-0.5937	*****	*****	*****	*****	-0.5937
0.550	-0.0711	-0.0300	0.0207	-0.0828	-0.5823	*****	*****	*****	*****	-0.5823
0.575	*****	-0.0320	0.0259	-0.0858	-0.5957	*****	*****	*****	*****	-0.5957
0.600	-0.0805	-0.0371	0.0089	-0.0845	-0.6021	*****	*****	*****	*****	-0.6021
0.625	*****	*****	0.0104	-0.0818	-0.6235	*****	*****	*****	*****	-0.6235
0.650	-0.0834	-0.0407	0.0038	-0.0814	-0.6658	*****	*****	*****	*****	-0.6658
0.675	*****	-0.0550	-0.0052	-0.0847	-0.6921	*****	*****	*****	*****	-0.6921
0.700	-0.0813	-0.0649	-0.0078	-0.0842	-0.7270	*****	*****	*****	*****	-0.7270
0.725	*****	-0.0746	*****	-0.0848	-0.7433	*****	*****	*****	*****	-0.7433
0.750	-0.0746	-0.0843	*****	-0.0861	-0.7439	*****	*****	*****	*****	-0.7439
0.775	*****	-0.0922	-0.0382	-0.0952	-0.7299	*****	*****	*****	*****	-0.7299
0.800	-0.0590	-0.0996	-0.0548	-0.1024	*****	*****	*****	*****	*****	-0.1024
0.825	*****	-0.1016	-0.0716	-0.1004	-0.6705	*****	*****	*****	*****	-0.6705
0.850	-0.0387	-0.1011	-0.0874	-0.1292	-0.6663	*****	*****	*****	*****	-0.6663
0.875	*****	-0.0954	-0.0995	-0.1463	-0.7292	*****	*****	*****	*****	-0.7292
0.900	-0.0102	-0.0882	-0.1048	-0.1647	-0.5558	*****	*****	*****	*****	-0.5558
0.925	*****	-0.0703	-0.0982	-0.1674	-0.7125	*****	*****	*****	*****	-0.7125
0.950	0.0369	-0.0363	-0.0781	-0.1509	-0.4348	*****	*****	*****	*****	-0.4348
0.975	*****	0.0145	-0.0280	-0.1024	-0.2820	*****	*****	*****	*****	-0.2820
1.000	0.2197	0.2121	0.1995	0.1526	0.0797	*****	*****	*****	*****	0.0797
	$C_{p,l}$	$C_{p,l}$	$C_{p,l}$	$C_{p,l}$	$C_{p,l}$	$C_{p,l}$	$C_{p,l}$	$C_{p,l}$	$C_{p,l}$	$C_{p,l}$
-0.200	0.0040	0.0234	0.1012	*****	-0.6517	*****	*****	*****	*****	-0.6517
-0.400	-0.0187	0.0268	0.0618	-0.0846	-0.6520	*****	*****	*****	*****	-0.6520
-0.600	-0.0327	0.0057	0.0399	-0.0610	-0.6934	*****	*****	*****	*****	-0.6934
-0.700	-0.0295	-0.0225	0.0217	-0.0563	-0.7236	*****	*****	*****	*****	-0.7236
-0.800	-0.0079	*****	-0.0141	-0.0613	-0.7065	*****	*****	*****	*****	-0.7065
-0.850	*****	-0.0336	-0.0339	-0.0808	-0.7329	*****	*****	*****	*****	-0.7329
-0.900	*****	-0.0116	-0.0351	-0.0988	-0.6019	*****	*****	*****	*****	-0.6019
-0.950	0.1032	0.0464	0.0133	-0.0652	-0.3412	*****	*****	*****	*****	-0.3412
-0.975	*****	0.1059	0.0707	-0.0004	-0.1985	*****	*****	*****	*****	-0.1985
-1.000	0.1953	0.1936	0.1589	0.1582	0.0787	*****	*****	*****	*****	0.0787

Medium Radius L.E.
 Run No. = 15 , Point No. = 315
 $C_N = 0.029$, $C_m = -0.0048$
 $\alpha = 0.7^\circ$, $M_\infty = 0.849$
 $R_{mac} = 96.1 \times 10^6$

Leading Edge Pressures

● starboard
 ○ port

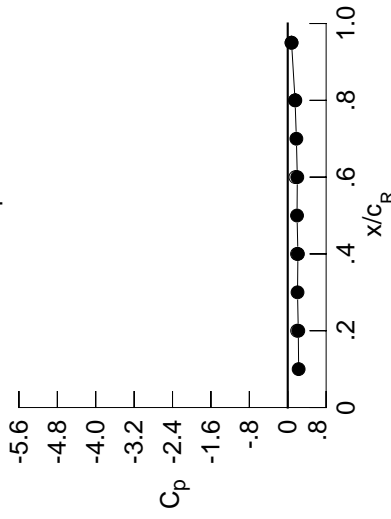

x/c_R	starb'd C_p	port C_p
0.10	0.2275	*****
0.20	0.2197	0.1953
0.30	0.2040	*****
0.40	0.2121	0.1936
0.50	0.1938	*****
0.60	0.1995	0.1589
0.70	0.1802	*****
0.80	0.1526	0.1582
0.90	*****	*****
0.95	0.0797	0.0787

Surface Pressures

● upper, starboard
 ○ lower, port

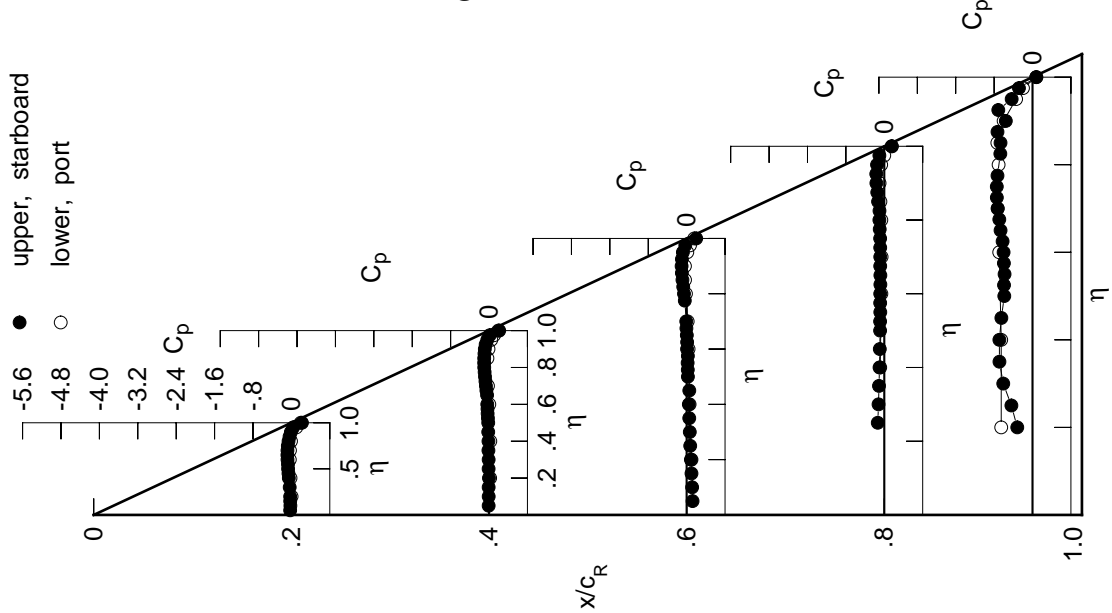

Table E9. Continued.

η	$x/c_R = .2$		$x/c_R = .4$		$x/c_R = .6$		$x/c_R = .8$		$x/c_R = .95$	
	$C_{p,u}$	$C_{p,u}$	$C_{p,u}$	$C_{p,u}$	$C_{p,u}$	$C_{p,u}$	$C_{p,u}$	$C_{p,u}$	$C_{p,u}$	$C_{p,u}$
0.050	-0.0463	-0.0262	0.1105	*****	*****	*****	*****	*****	*****	*****
0.100	-0.0412	-0.0258	0.1016	*****	*****	*****	*****	*****	*****	*****
0.150	-0.0460	-0.0267	0.0879	*****	*****	*****	*****	*****	*****	*****
0.200	-0.0465	-0.0215	0.0753	*****	*****	*****	*****	*****	*****	-0.2880
0.250	*****	-0.0286	0.0605	-0.1485	-0.4002	*****	*****	*****	*****	*****
0.300	-0.0575	-0.0284	0.0515	-0.1335	-0.5772	*****	*****	*****	*****	*****
0.350	*****	-0.0338	0.0393	-0.1242	-0.7054	*****	*****	*****	*****	*****
0.400	-0.0781	-0.0332	0.0301	-0.1127	-0.7314	*****	*****	*****	*****	*****
0.450	-0.0871	-0.0395	0.0383	-0.1070	-0.6991	*****	*****	*****	*****	*****
0.500	-0.0971	-0.0397	0.0091	-0.1019	-0.6301	*****	*****	*****	*****	*****
0.525	*****	-0.0473	0.0059	-0.1026	-0.6291	*****	*****	*****	*****	*****
0.550	-0.1015	-0.0534	0.0023	-0.0986	-0.6171	*****	*****	*****	*****	*****
0.575	*****	-0.0582	0.0065	-0.1014	-0.6321	*****	*****	*****	*****	*****
0.600	-0.1128	-0.0634	-0.0110	-0.1017	-0.6482	*****	*****	*****	*****	*****
0.625	*****	*****	-0.0106	-0.0998	-0.6780	*****	*****	*****	*****	*****
0.650	-0.1192	-0.0692	-0.0176	-0.0998	-0.7193	*****	*****	*****	*****	*****
0.675	*****	-0.0855	-0.0284	-0.1047	-0.7284	*****	*****	*****	*****	*****
0.700	-0.1196	-0.0978	-0.0321	-0.1048	-0.7364	*****	*****	*****	*****	*****
0.725	*****	-0.1103	*****	-0.1069	-0.7096	*****	*****	*****	*****	*****
0.750	-0.1162	-0.1227	*****	-0.1097	-0.5957	*****	*****	*****	*****	*****
0.775	*****	-0.1337	-0.0694	-0.1213	-0.4347	*****	*****	*****	*****	*****
0.800	-0.1043	-0.1451	-0.0908	-0.1313	*****	*****	*****	*****	*****	*****
0.825	*****	-0.1513	-0.1126	-0.1313	-0.3790	*****	*****	*****	*****	*****
0.850	-0.0878	-0.1551	-0.1343	-0.1661	-0.4415	*****	*****	*****	*****	*****
0.875	*****	-0.1546	-0.1531	-0.1909	-0.7214	*****	*****	*****	*****	*****
0.900	-0.0638	-0.1527	-0.1667	-0.2189	-0.6392	*****	*****	*****	*****	*****
0.925	*****	-0.1402	-0.1688	-0.2333	-0.8812	*****	*****	*****	*****	*****
0.950	-0.0236	-0.1126	-0.1592	-0.2294	-0.4799	*****	*****	*****	*****	*****
0.975	*****	-0.0742	-0.1222	-0.1980	-0.3526	*****	*****	*****	*****	*****
1.000	0.1834	0.1475	0.1111	0.0563	0.0107	*****	*****	*****	*****	*****
-0.200	$C_{p,l}$	$C_{p,l}$	$C_{p,l}$	$C_{p,l}$	$C_{p,l}$	$C_{p,l}$	$C_{p,l}$	$C_{p,l}$	$C_{p,l}$	$C_{p,l}$
-0.400	0.0241	0.0411	0.1131	*****	-0.6628	*****	*****	*****	*****	*****
-0.600	0.0045	0.0455	0.0764	-0.0717	-0.7073	*****	*****	*****	*****	*****
-0.700	-0.0032	0.0294	0.0571	-0.0462	-0.7342	*****	*****	*****	*****	*****
-0.800	0.0044	0.0068	0.0444	-0.0383	-0.7321	*****	*****	*****	*****	*****
-0.850	0.0307	*****	0.0164	-0.0369	-0.6909	*****	*****	*****	*****	*****
-0.900	*****	0.0100	0.0049	-0.0495	-0.7102	*****	*****	*****	*****	*****
-0.950	0.1441	0.0976	0.0681	-0.0558	-0.7374	*****	*****	*****	*****	*****
-0.975	*****	0.1557	0.1260	0.0575	-0.1535	*****	*****	*****	*****	*****
-1.000	0.1615	0.1385	0.0800	0.0796	0.0235	*****	*****	*****	*****	*****

Medium Radius L.E.
 Run No. = 15 , Point No. = 316
 $C_N = 0.072$, $C_m = -0.0117$
 $\alpha = 1.8^\circ$, $M_\infty = 0.849$
 $R_{mac} = 96.0 \times 10^6$

Leading Edge Pressures

● starboard
 ○ port

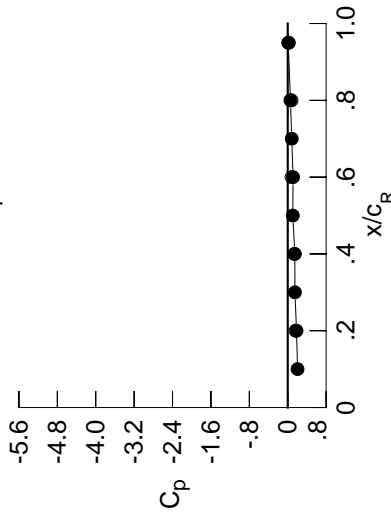

x/c_R	starb'd C_p	port C_p
0.10	0.2043	*****
0.20	0.1834	0.1615
0.30	0.1501	*****
0.40	0.1475	0.1385
0.50	0.1058	*****
0.60	0.1111	0.0800
0.70	0.0839	*****
0.80	0.0563	0.0796
0.90	*****	*****
0.95	0.0107	0.0235

Surface Pressures

● upper, starboard
 ○ lower, port

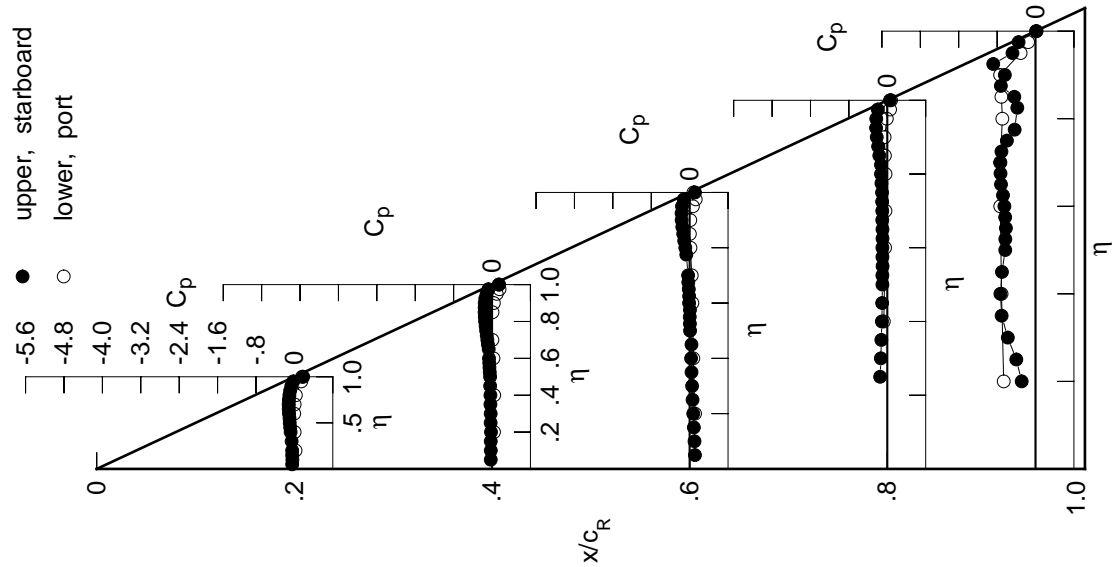

Table E9. Continued.

η	$x/c_R = .2$		$x/c_R = .4$		$x/c_R = .6$		$x/c_R = .8$		$x/c_R = .95$	
	$C_{p,u}$	$C_{p,u}$	$C_{p,u}$	$C_{p,u}$	$C_{p,u}$	$C_{p,u}$	$C_{p,u}$	$C_{p,u}$	$C_{p,u}$	$C_{p,u}$
0.050	-0.0657	-0.0441	0.0981	*****	*****	*****	*****	*****	*****	*****
0.100	-0.0617	-0.0438	0.0883	*****	*****	*****	*****	*****	*****	*****
0.150	-0.0660	-0.0453	0.0750	*****	*****	*****	*****	*****	*****	*****
0.200	-0.0676	-0.0403	0.0621	*****	*****	*****	*****	*****	*****	*****
0.250	*****	-0.0467	0.0472	0.1610	-0.3874	*****	*****	*****	*****	*****
0.300	-0.0789	-0.0476	0.0378	-0.1455	-0.5358	*****	*****	*****	*****	*****
0.350	*****	-0.0527	0.0245	-0.1366	-0.6753	*****	*****	*****	*****	*****
0.400	-0.1016	-0.0533	0.0154	-0.1254	-0.7231	*****	*****	*****	*****	*****
0.450	-0.1121	-0.0601	0.0220	-0.1209	-0.7001	*****	*****	*****	*****	*****
0.500	-0.1236	-0.0618	-0.0076	-0.1161	-0.6398	*****	*****	*****	*****	*****
0.525	*****	-0.0696	-0.0118	-0.1169	-0.6409	*****	*****	*****	*****	*****
0.550	-0.1307	-0.0785	-0.0160	-0.1134	-0.6340	*****	*****	*****	*****	*****
0.575	*****	-0.0820	-0.0127	-0.1168	-0.6561	*****	*****	*****	*****	*****
0.600	-0.1444	-0.0894	-0.0307	-0.1178	-0.6781	*****	*****	*****	*****	*****
0.625	*****	*****	-0.0315	-0.1165	-0.7052	*****	*****	*****	*****	*****
0.650	-0.1536	-0.0965	-0.0393	-0.1173	-0.7356	*****	*****	*****	*****	*****
0.675	*****	-0.1143	-0.0514	-0.1234	-0.7262	*****	*****	*****	*****	*****
0.700	-0.1576	-0.1290	-0.0571	-0.1249	-0.6825	*****	*****	*****	*****	*****
0.725	*****	-0.1444	*****	-0.1284	-0.5721	*****	*****	*****	*****	*****
0.750	-0.1579	-0.1598	*****	-0.1329	-0.4315	*****	*****	*****	*****	*****
0.775	*****	-0.1750	-0.1008	-0.1469	-0.3078	*****	*****	*****	*****	*****
0.800	-0.1502	-0.1901	-0.1256	-0.1601	*****	*****	*****	*****	*****	*****
0.825	*****	-0.2009	-0.1527	-0.1620	-0.3086	*****	*****	*****	*****	*****
0.850	-0.1387	-0.2098	-0.1810	-0.2034	-0.3317	*****	*****	*****	*****	*****
0.875	*****	-0.2147	-0.2080	-0.2362	-0.5270	*****	*****	*****	*****	*****
0.900	-0.1209	-0.2185	-0.2309	-0.2749	-0.6267	*****	*****	*****	*****	*****
0.925	*****	-0.2142	-0.2432	-0.3009	-0.8171	*****	*****	*****	*****	*****
0.950	-0.0890	-0.1952	-0.2469	-0.3131	-0.5283	*****	*****	*****	*****	*****
0.975	*****	-0.1726	-0.2290	-0.3035	-0.4315	*****	*****	*****	*****	*****
1.000	0.1167	0.0330	-0.0205	-0.1102	-0.1144	*****	*****	*****	*****	*****
-0.200	$C_{p,l}$	$C_{p,l}$	$C_{p,l}$	$C_{p,l}$	$C_{p,l}$	$C_{p,l}$	$C_{p,l}$	$C_{p,l}$	$C_{p,l}$	$C_{p,l}$
-0.400	0.0454	0.0589	0.1267	*****	-0.6684	*****	*****	*****	*****	*****
-0.600	0.0280	0.0638	0.0919	-0.0593	-0.7380	*****	*****	*****	*****	*****
-0.700	0.0252	0.0524	0.0753	-0.0313	-0.7447	*****	*****	*****	*****	*****
-0.800	0.0366	0.0339	0.0655	-0.0216	-0.7261	*****	*****	*****	*****	*****
-0.850	0.0657	*****	0.0439	-0.0155	-0.6753	*****	*****	*****	*****	*****
-0.900	*****	0.0483	0.0387	-0.0221	-0.6892	*****	*****	*****	*****	*****
-0.950	*****	0.0793	0.0537	-0.0184	-0.7232	*****	*****	*****	*****	*****
-0.975	0.1767	0.1382	0.1115	0.0358	-0.2857	*****	*****	*****	*****	*****
-1.000	0.0966	0.0328	-0.0798	-0.0666	-0.0734	*****	*****	*****	*****	*****

Medium Radius L.E.
 Run No. = 15, Point No. = 317
 $C_N = 0.113$, $C_m = -0.0179$
 $\alpha = 2.9^\circ$, $M_\infty = 0.849$
 $R_{mac} = 95.7 \times 10^6$

Leading Edge Pressures

- starboard
- port

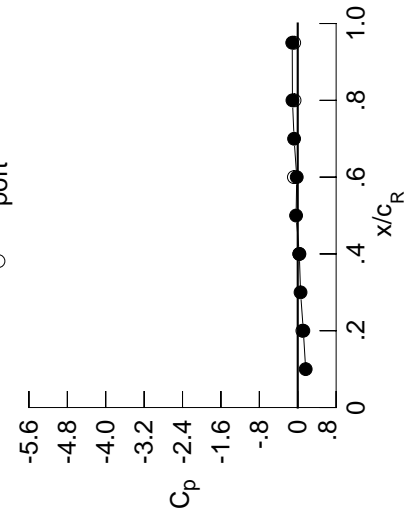

x/c_R	starb'd C_p	port C_p
0.10	0.1653	*****
0.20	0.1167	0.0966
0.30	0.0587	*****
0.40	0.0330	0.0328
0.50	-0.0346	*****
0.60	-0.0205	-0.0798
0.70	-0.0760	*****
0.80	-0.1102	-0.0666
0.90	*****	*****
0.95	-0.1144	-0.0734

Surface Pressures

- upper, starboard
- lower, port

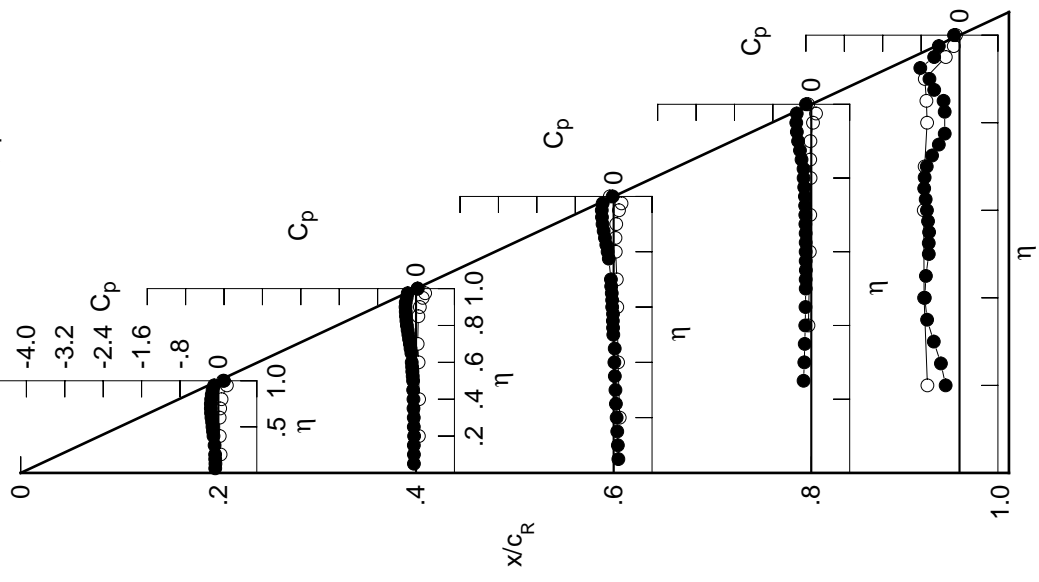

Table E9. Continued.

η	$x/c_R = .2$		$x/c_R = .4$		$x/c_R = .6$		$x/c_R = .8$		$x/c_R = .95$	
	$C_{p,u}$	$C_{p,u}$	$C_{p,u}$	$C_{p,u}$	$C_{p,u}$	$C_{p,u}$	$C_{p,u}$	$C_{p,u}$	$C_{p,u}$	$C_{p,u}$
0.050	-0.0847	-0.0609	0.0862	0.0862	0.0862	0.0862	0.0862	0.0862	0.0862	0.0862
0.100	-0.0810	-0.0611	0.0769	0.0769	0.0769	0.0769	0.0769	0.0769	0.0769	0.0769
0.150	-0.0851	-0.0621	0.0633	0.0633	0.0633	0.0633	0.0633	0.0633	0.0633	0.0633
0.200	-0.0865	-0.0574	0.0500	0.0500	0.0500	0.0500	0.0500	0.0500	0.0500	0.0500
0.250	0.0000	-0.0640	0.0345	0.0345	0.0345	0.0345	0.0345	0.0345	0.0345	0.0345
0.300	-0.0986	-0.0656	0.0250	0.0250	0.0250	0.0250	0.0250	0.0250	0.0250	0.0250
0.350	0.0000	-0.0712	0.0117	0.0117	0.0117	0.0117	0.0117	0.0117	0.0117	0.0117
0.400	-0.1235	-0.0724	0.0008	0.0008	0.0008	0.0008	0.0008	0.0008	0.0008	0.0008
0.450	-0.1362	-0.0799	0.0073	0.0073	0.0073	0.0073	0.0073	0.0073	0.0073	0.0073
0.500	-0.1496	-0.0831	-0.0234	-0.0234	-0.0234	-0.0234	-0.0234	-0.0234	-0.0234	-0.0234
0.525	0.0000	-0.0918	-0.0282	-0.0282	-0.0282	-0.0282	-0.0282	-0.0282	-0.0282	-0.0282
0.550	-0.1592	-0.1013	-0.0332	-0.0332	-0.0332	-0.0332	-0.0332	-0.0332	-0.0332	-0.0332
0.575	0.0000	-0.1067	-0.0303	-0.0303	-0.0303	-0.0303	-0.0303	-0.0303	-0.0303	-0.0303
0.600	-0.1751	-0.1144	-0.0493	-0.0493	-0.0493	-0.0493	-0.0493	-0.0493	-0.0493	-0.0493
0.625	0.0000	0.0000	-0.0507	-0.0507	-0.0507	-0.0507	-0.0507	-0.0507	-0.0507	-0.0507
0.650	-0.1876	-0.1233	-0.0601	-0.0601	-0.0601	-0.0601	-0.0601	-0.0601	-0.0601	-0.0601
0.675	0.0000	-0.1436	-0.0731	-0.0731	-0.0731	-0.0731	-0.0731	-0.0731	-0.0731	-0.0731
0.700	-0.1954	-0.1604	-0.0812	-0.0812	-0.0812	-0.0812	-0.0812	-0.0812	-0.0812	-0.0812
0.725	0.0000	-0.1789	0.0000	0.0000	-0.1498	-0.1498	-0.1498	-0.1498	-0.1498	-0.1498
0.750	-0.1997	-0.1981	0.0000	0.0000	-0.1563	-0.1563	-0.1563	-0.1563	-0.1563	-0.1563
0.775	0.0000	-0.2170	-0.1322	-0.1322	-0.1723	-0.1723	-0.1723	-0.1723	-0.1723	-0.1723
0.800	-0.1969	-0.2365	-0.1611	-0.1611	-0.1889	-0.1889	-0.1889	-0.1889	-0.1889	-0.1889
0.825	0.0000	-0.2525	-0.1944	-0.1944	-0.1932	-0.1932	-0.1932	-0.1932	-0.1932	-0.1932
0.850	-0.1905	-0.2660	-0.2292	-0.2292	-0.2404	-0.2404	-0.2404	-0.2404	-0.2404	-0.2404
0.875	0.0000	-0.2781	-0.2651	-0.2651	-0.2820	-0.2820	-0.2820	-0.2820	-0.2820	-0.2820
0.900	-0.1799	-0.2890	-0.2984	-0.2984	-0.3325	-0.3325	-0.3325	-0.3325	-0.3325	-0.3325
0.925	0.0000	-0.2942	-0.3232	-0.3232	-0.3734	-0.3734	-0.3734	-0.3734	-0.3734	-0.3734
0.950	-0.1591	-0.2860	-0.3439	-0.3439	-0.4046	-0.4046	-0.4046	-0.4046	-0.4046	-0.4046
0.975	0.0000	-0.2849	-0.3500	-0.3500	-0.4247	-0.4247	-0.4247	-0.4247	-0.4247	-0.4247
1.000	0.0232	-0.1330	-0.1938	-0.1938	-0.3416	-0.3416	-0.2882	-0.2882	-0.2882	-0.2882
-0.200	$C_{p,l}$	0.0667	0.0774	0.1410	0.1410	0.1410	0.1410	0.1410	0.1410	0.1410
-0.400	$C_{p,l}$	0.0519	0.0834	0.1072	0.1072	0.1072	0.1072	0.1072	0.1072	0.1072
-0.600	$C_{p,l}$	0.0541	0.0755	0.0929	0.0929	0.0929	0.0929	0.0929	0.0929	0.0929
-0.700	$C_{p,l}$	0.0681	0.0614	0.0867	0.0867	0.0867	0.0867	0.0867	0.0867	0.0867
-0.800	$C_{p,l}$	0.0994	0.0000	0.0715	0.0715	0.0715	0.0715	0.0715	0.0715	0.0715
-0.850	$C_{p,l}$	0.0852	0.0852	0.0715	0.0715	0.0715	0.0715	0.0715	0.0715	0.0715
-0.900	$C_{p,l}$	0.1176	0.1176	0.0909	0.0909	0.0909	0.0909	0.0909	0.0909	0.0909
-0.950	$C_{p,l}$	0.2026	0.1716	0.1479	0.1479	0.1479	0.1479	0.1479	0.1479	0.1479
-0.975	$C_{p,l}$	0.2108	0.2108	0.1904	0.1904	0.1904	0.1904	0.1904	0.1904	0.1904
-1.000	$C_{p,l}$	0.0036	-0.1176	-0.3051	-0.3051	-0.2844	-0.2844	-0.2844	-0.2844	-0.2844

Medium Radius L.E.
 Run No. = 15 , Point No. = 318
 $C_N = 0.156, C_m = -0.0258$
 $\alpha = 3.9^\circ, M_\infty = 0.849$
 $R_{mac} = 95.6 \times 10^6$

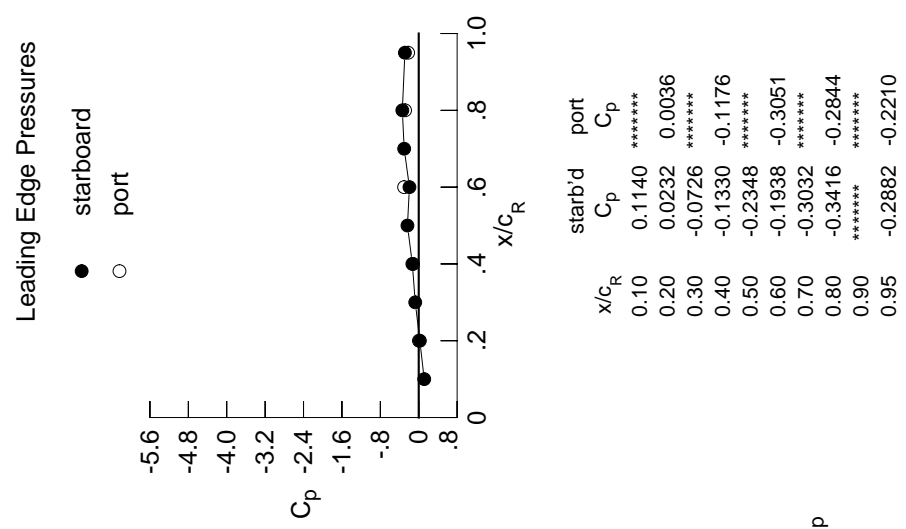

Table E9. Continued.

η	$x/c_R = .2$		$x/c_R = .4$		$x/c_R = .6$		$x/c_R = .8$		$x/c_R = .95$	
	$C_{p,u}$	$C_{p,u}$	$C_{p,u}$	$C_{p,u}$	$C_{p,u}$	$C_{p,u}$	$C_{p,u}$	$C_{p,u}$	$C_{p,u}$	$C_{p,u}$
0.050	-0.1009	-0.0748	0.0769	*****	*****	*****	*****	*****	*****	
0.100	-0.0979	-0.0759	0.0675	*****	*****	*****	*****	*****	*****	
0.150	-0.1023	-0.0775	0.0536	*****	*****	*****	*****	*****	*****	
0.200	-0.1040	-0.0725	0.0406	*****	*****	*****	*****	*****	-0.3327	
0.250	*****	-0.0795	0.0247	-0.1825	-0.3938	*****	*****	*****	*****	
0.300	-0.1160	-0.0815	0.0142	-0.1675	-0.5058	*****	*****	*****	*****	
0.350	*****	-0.0880	0.0001	-0.1591	-0.6339	*****	*****	*****	*****	
0.400	-0.1442	-0.0896	-0.0113	-0.1483	-0.7008	*****	*****	*****	*****	
0.450	-0.1579	-0.0984	-0.0058	-0.1446	-0.7021	*****	*****	*****	*****	
0.500	-0.1738	-0.1019	-0.0378	-0.1417	-0.6678	*****	*****	*****	*****	
0.525	*****	-0.1124	-0.0431	-0.1433	-0.6684	*****	*****	*****	*****	
0.550	-0.1858	-0.1225	-0.0486	-0.1410	-0.6515	*****	*****	*****	*****	
0.575	*****	-0.1286	-0.0462	-0.1456	-0.6543	*****	*****	*****	*****	
0.600	-0.2049	-0.1377	-0.0672	-0.1484	-0.6508	*****	*****	*****	*****	
0.625	*****	*****	-0.0692	-0.1481	-0.6547	*****	*****	*****	*****	
0.650	-0.2210	-0.1486	-0.0790	-0.1511	-0.6819	*****	*****	*****	*****	
0.675	*****	-0.1711	-0.0931	-0.1594	-0.6968	*****	*****	*****	*****	
0.700	-0.2325	-0.1899	-0.1028	-0.1633	-0.7258	*****	*****	*****	*****	
0.725	*****	-0.2122	*****	-0.1702	-0.7451	*****	*****	*****	*****	
0.750	-0.2418	-0.2334	*****	-0.1788	-0.7243	*****	*****	*****	*****	
0.775	*****	-0.2572	-0.1620	-0.1970	-0.6306	*****	*****	*****	*****	
0.800	-0.2442	-0.2806	-0.1958	-0.2167	*****	*****	*****	*****	*****	
0.825	*****	-0.3017	-0.2340	-0.2241	-0.5133	*****	*****	*****	*****	
0.850	-0.2439	-0.3218	-0.2759	-0.2771	-0.3674	*****	*****	*****	*****	
0.875	*****	-0.3412	-0.3208	-0.3270	-0.3508	*****	*****	*****	*****	
0.900	-0.2417	-0.3603	-0.3673	-0.3911	-0.3678	*****	*****	*****	*****	
0.925	*****	-0.3761	-0.4043	-0.4474	-0.3803	*****	*****	*****	*****	
0.950	-0.2345	-0.3827	-0.4441	-0.4990	-0.6388	*****	*****	*****	*****	
0.975	*****	-0.4060	-0.4891	-0.5540	-0.6201	*****	*****	*****	*****	
1.000	-0.0953	-0.3284	-0.3882	-0.6390	-0.5247	*****	*****	*****	*****	
-0.200	$C_{p,l}$	0.0968	0.1558	*****	-0.6622	$C_{p,l}$	$C_{p,l}$	$C_{p,l}$	$C_{p,l}$	
-0.400	0.0757	0.1041	0.1232	-0.0317	-0.7323	0.0888	0.0968	0.1558	*****	
-0.600	0.0821	0.0975	0.1116	0.0000	-0.7258	0.0757	0.1041	0.1232	-0.0317	
-0.700	0.0979	0.0873	0.1078	0.0139	-0.7010	0.0821	0.0975	0.1116	0.0000	
-0.800	0.1303	*****	0.0964	0.0282	-0.6419	0.0979	0.0873	0.1078	0.0139	
-0.850	*****	0.1177	0.1003	0.0302	-0.6482	0.1303	*****	0.0964	0.0282	
-0.900	*****	0.1502	0.1224	0.0467	-0.6545	*****	0.1177	0.1003	0.0302	
-0.950	0.2226	0.1971	0.1749	0.1045	-0.2432	*****	0.1502	0.1224	0.0467	
-0.975	*****	0.2213	0.2046	0.1485	-0.0739	0.2226	0.1971	0.1749	0.1045	
-1.000	-0.1090	-0.2861	-0.5832	-0.5748	-0.4157	*****	0.2213	0.2046	0.1485	

Medium Radius L.E.
 Run No. = 15, Point No. = 319
 $C_N = 0.196$, $C_m = -0.0319$
 $\alpha = 4.9^\circ$, $M_\infty = 0.849$
 $R_{mac} = 95.9 \times 10^6$

Leading Edge Pressures

● starboard
 ○ port

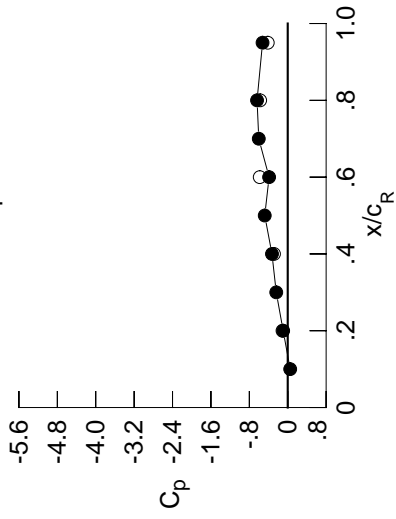

x/c_R	starb'd C_p	port C_p
0.10	0.0511	*****
0.20	-0.0953	-0.1090
0.30	-0.2393	*****
0.40	-0.3284	-0.2861
0.50	-0.4789	*****
0.60	-0.3882	-0.5832
0.70	-0.6033	*****
0.80	-0.6390	-0.5748
0.90	*****	*****
0.95	-0.5247	-0.4157

Surface Pressures

● upper, starboard
 ○ lower, port

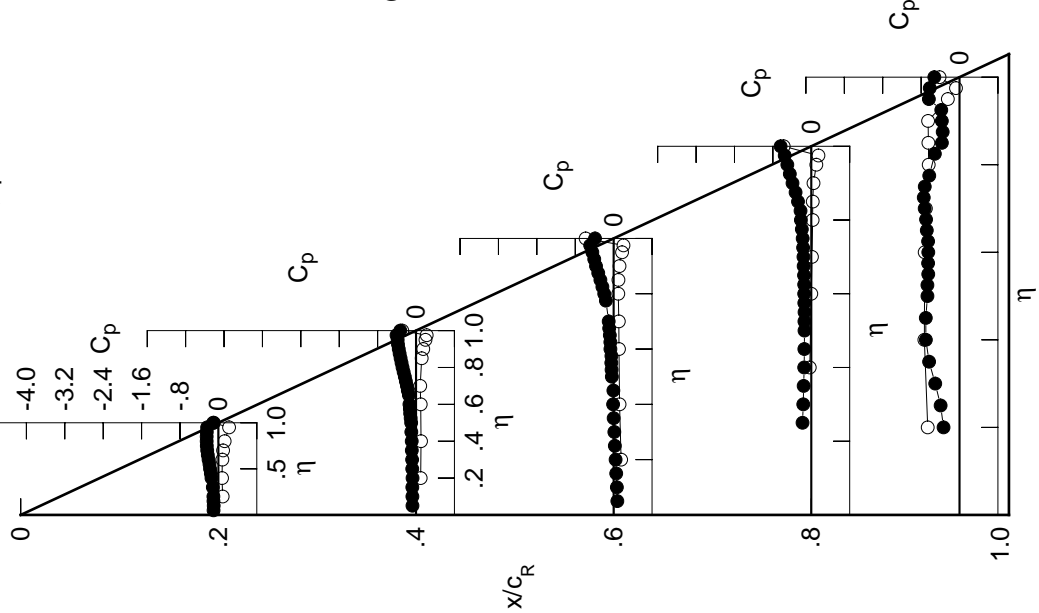

Table E9. Continued.

η	$x/c_R = .2$		$x/c_R = .4$		$x/c_R = .6$		$x/c_R = .8$		$x/c_R = .95$	
	$C_{p,u}$	$C_{p,u}$	$C_{p,u}$	$C_{p,u}$	$C_{p,u}$	$C_{p,u}$	$C_{p,u}$	$C_{p,u}$	$C_{p,u}$	$C_{p,u}$
0.050	-0.1193	-0.0926	0.0652	*****	*****	*****	*****	*****	*****	
0.100	-0.1173	-0.0931	0.0560	*****	*****	*****	*****	*****	*****	
0.150	-0.1214	-0.0951	0.0422	*****	*****	*****	*****	*****	*****	
0.200	-0.1239	-0.0905	0.0283	*****	*****	*****	*****	*****	*****	
0.250	*****	-0.0985	0.0113	-0.1947	-0.3907	*****	*****	*****	*****	
0.300	-0.1376	-0.1009	0.0011	-0.1795	-0.4653	*****	*****	*****	*****	
0.350	*****	-0.1081	-0.0138	-0.1717	-0.5595	*****	*****	*****	*****	
0.400	-0.1679	-0.1100	-0.0263	-0.1611	-0.6261	*****	*****	*****	*****	
0.450	-0.1832	-0.1206	-0.0210	-0.1583	-0.6336	*****	*****	*****	*****	
0.500	-0.2011	-0.1254	-0.0544	-0.1559	-0.6058	*****	*****	*****	*****	
0.525	*****	-0.1365	-0.0603	-0.1581	-0.6108	*****	*****	*****	*****	
0.550	-0.2157	-0.1473	-0.0671	-0.1559	-0.5875	*****	*****	*****	*****	
0.575	*****	-0.1550	-0.0655	-0.1613	-0.5854	*****	*****	*****	*****	
0.600	-0.2379	-0.1647	-0.0873	-0.1655	-0.5831	*****	*****	*****	*****	
0.625	*****	*****	-0.0904	-0.1660	-0.6031	*****	*****	*****	*****	
0.650	-0.2580	-0.1797	-0.1016	-0.1700	-0.6304	*****	*****	*****	*****	
0.675	*****	-0.2035	-0.1175	-0.1796	-0.6279	*****	*****	*****	*****	
0.700	-0.2742	-0.2256	-0.1291	-0.1856	-0.6311	*****	*****	*****	*****	
0.725	*****	-0.2499	*****	-0.1952	-0.6258	*****	*****	*****	*****	
0.750	-0.2885	-0.2758	*****	-0.2077	-0.5775	*****	*****	*****	*****	
0.775	*****	-0.3035	-0.1979	-0.2296	-0.5051	*****	*****	*****	*****	
0.800	-0.2974	-0.3331	-0.2347	-0.2513	*****	*****	*****	*****	*****	
0.825	*****	-0.3606	-0.2786	-0.2622	-0.4528	*****	*****	*****	*****	
0.850	-0.3049	-0.3869	-0.3285	-0.3163	-0.3414	*****	*****	*****	*****	
0.875	*****	-0.4151	-0.3854	-0.3728	-0.3422	*****	*****	*****	*****	
0.900	-0.3133	-0.4442	-0.4437	-0.4477	-0.3584	*****	*****	*****	*****	
0.925	*****	-0.4752	-0.4984	-0.5213	-0.3607	*****	*****	*****	*****	
0.950	-0.3235	-0.4987	-0.5581	-0.6027	-0.6987	*****	*****	*****	*****	
0.975	*****	-0.5614	-0.6297	-0.7066	-0.7394	*****	*****	*****	*****	
1.000	-0.2490	-0.5946	-0.6180	-0.9459	-0.8022	*****	*****	*****	*****	
-0.200	$C_{p,l}$	$C_{p,l}$	$C_{p,l}$	$C_{p,l}$	$C_{p,l}$	$C_{p,l}$	$C_{p,l}$	$C_{p,l}$	$C_{p,l}$	
-0.400	0.1115	0.1164	0.1699	*****	*****	-0.6497	*****	*****	*****	
-0.600	0.1008	0.1243	0.1394	-0.0184	-0.7287	*****	*****	*****	*****	
-0.700	0.1103	0.1216	0.1296	0.0167	-0.7151	*****	*****	*****	*****	
-0.800	0.1288	0.1137	0.1280	0.0317	-0.6888	*****	*****	*****	*****	
-0.850	0.1611	*****	0.1213	0.0484	-0.6267	*****	*****	*****	*****	
-0.900	*****	0.1493	0.1288	0.0548	-0.6290	*****	*****	*****	*****	
-0.950	0.2379	0.2168	0.1966	0.1298	-0.2284	*****	*****	*****	*****	
-0.975	*****	0.2210	0.2088	0.1585	-0.0648	*****	*****	*****	*****	
-1.000	-0.2585	-0.5026	-0.8267	-0.8776	-0.7016	*****	*****	*****	*****	

Medium Radius L.E.

Run No. = 15 , Point No. = 320

$C_N = 0.242$, $C_m = -0.0395$

$\alpha = 6.0^\circ$, $M_\infty = 0.849$

$R_{mac} = 96.4 \times 10^6$

Leading Edge Pressures

● starboard
○ port

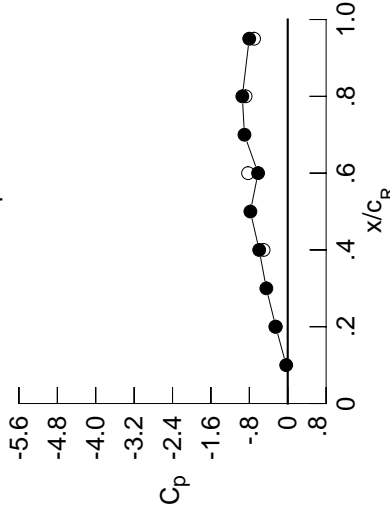

x/c_R	starb'd C_p	port C_p
0.10	-0.0320	*****
0.20	-0.2490	-0.2585
0.30	-0.4459	*****
0.40	-0.5946	-0.5026
0.50	-0.7786	*****
0.60	-0.6180	-0.8267
0.70	-0.9018	*****
0.80	-0.9459	-0.8776
0.90	*****	*****
0.95	-0.8022	-0.7016

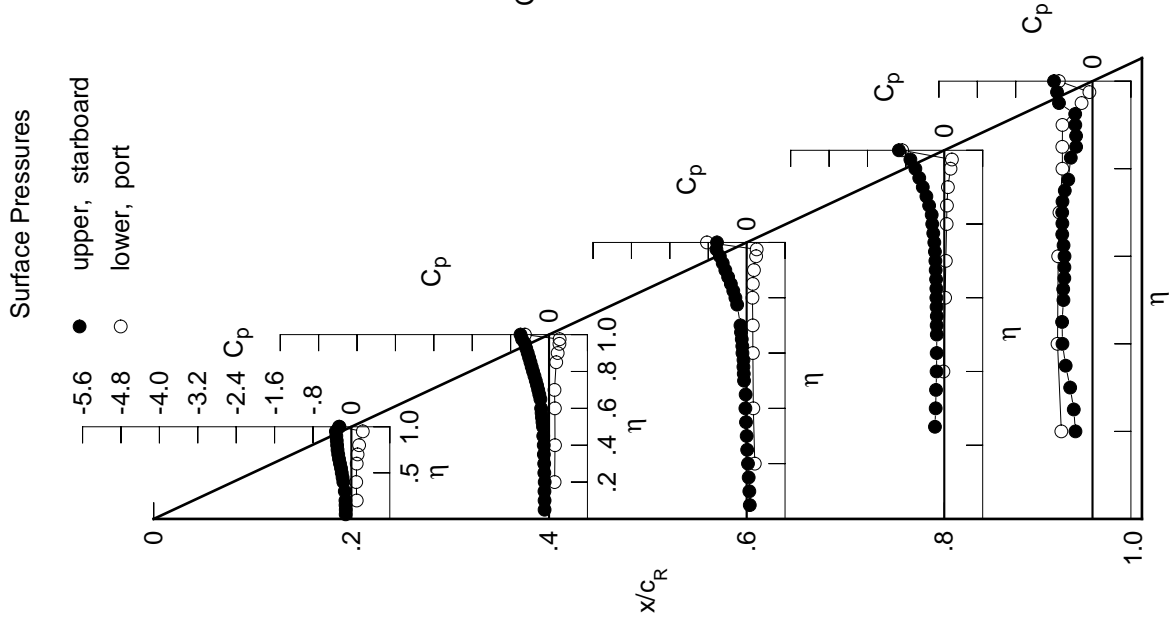

Table E9. Continued.

η	x/c_R .2	x/c_R .4	x/c_R .6	x/c_R .8	x/c_R .95
	$C_{p,u}$	$C_{p,u}$	$C_{p,u}$	$C_{p,u}$	$C_{p,u}$
0.050	-0.1364	-0.1087	0.0541	*****	*****
0.100	-0.1355	-0.1100	0.0440	*****	*****
0.150	-0.1402	-0.1124	0.0301	*****	*****
0.200	-0.1430	-0.1076	0.0158	*****	-0.3443
0.250	*****	-0.1162	-0.0016	-0.2069	-0.3640
0.300	-0.1583	-0.1194	-0.0122	-0.1919	-0.4151
0.350	*****	-0.1273	-0.0280	-0.1845	-0.4663
0.400	-0.1909	-0.1293	-0.0411	-0.1744	-0.5440
0.450	-0.2078	-0.1420	-0.0364	-0.1718	-0.6044
0.500	-0.2282	-0.1475	-0.0709	-0.1700	-0.6749
0.525	*****	-0.1603	-0.0781	-0.1715	-0.7090
0.550	-0.2457	-0.1723	-0.0846	-0.1702	-0.7005
0.575	*****	-0.1805	-0.0845	-0.1775	-0.7015
0.600	-0.2710	-0.1922	-0.1089	-0.1847	-0.6809
0.625	*****	*****	-0.1133	-0.1886	-0.6528
0.650	-0.2948	-0.2094	-0.1276	-0.1964	-0.6227
0.675	*****	-0.2349	-0.1462	-0.2110	-0.5621
0.700	-0.3165	-0.2592	-0.1618	-0.2233	-0.5144
0.725	*****	-0.2867	*****	-0.2382	-0.4756
0.750	-0.3363	-0.3159	*****	-0.2539	-0.4163
0.775	*****	-0.3491	-0.2357	-0.2752	-0.3380
0.800	-0.3527	-0.3826	-0.2735	-0.2960	*****
0.825	*****	-0.4180	-0.3195	-0.3101	-0.2987
0.850	-0.3681	-0.4522	-0.3725	-0.3575	-0.2976
0.875	*****	-0.4913	-0.4344	-0.4032	-0.3400
0.900	-0.3903	-0.5310	-0.5029	-0.4826	-0.4942
0.925	*****	-0.5755	-0.5710	-0.5727	-0.6987
0.950	-0.4170	-0.6167	-0.6480	-0.6784	-0.7225
0.975	*****	-0.7138	-0.8028	-0.8876	-0.7764
1.000	-0.4229	-0.8604	-0.7794	-1.1627	-1.0011
	$C_{p,l}$	$C_{p,l}$	$C_{p,l}$	$C_{p,l}$	$C_{p,l}$
-0.200	0.1356	0.1372	0.1858	*****	-0.6412
-0.400	0.1257	0.1456	0.1555	-0.0031	-0.7253
-0.600	0.1388	0.1450	0.1484	0.0306	-0.7043
-0.700	0.1582	0.1398	0.1479	0.0475	-0.6771
-0.800	0.1896	*****	0.1445	0.0675	-0.6114
-0.850	*****	0.1782	0.1541	0.0763	-0.6120
-0.900	*****	0.2057	0.1764	0.0992	-0.6010
-0.950	0.2462	0.2298	0.2112	0.1476	-0.2169
-0.975	*****	0.2126	0.2042	0.1601	-0.0611
-1.000	-0.4406	-0.7262	-1.0277	-1.0685	-0.8823

Medium Radius L.E.
 Run No. = 15, Point No. = 321
 $C_N = 0.287$, $C_m = -0.0472$
 $\alpha = 7.1^\circ$, $M_\infty = 0.847$
 $R_{mac} = 96.3 \times 10^6$

Leading Edge Pressures

● starboard
 ○ port

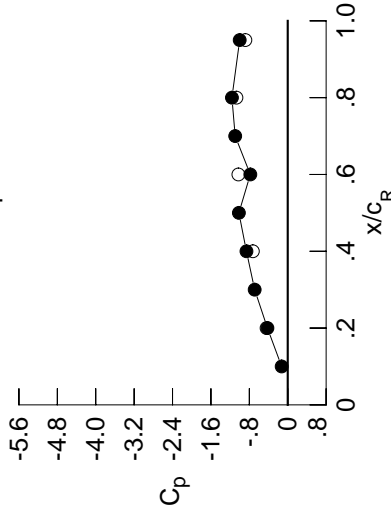

x/c_R	starb'd C_p	port C_p
0.10	-0.1266	*****
0.20	-0.4229	-0.4406
0.30	-0.6887	*****
0.40	-0.8604	-0.7262
0.50	-1.0174	*****
0.60	-0.7794	-1.0277
0.70	-1.0947	*****
0.80	-1.1627	-1.0685
0.90	*****	*****
0.95	-1.0011	-0.8823

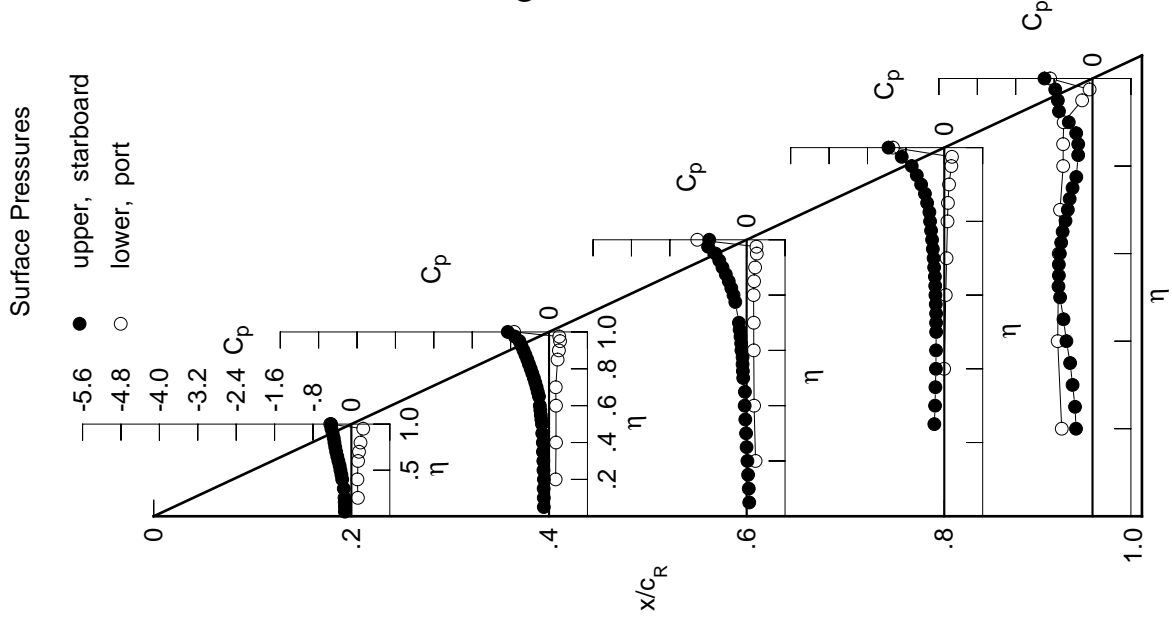

Table E9. Continued.

η	$x/c_R = .2$		$x/c_R = .4$		$x/c_R = .6$		$x/c_R = .8$		$x/c_R = .95$	
	$C_{p,u}$	$C_{p,u}$	$C_{p,u}$	$C_{p,u}$	$C_{p,u}$	$C_{p,u}$	$C_{p,u}$	$C_{p,u}$	$C_{p,u}$	$C_{p,u}$
0.050	-0.1501	-0.1229	0.0413	*****	*****	*****	*****	*****	*****	
0.100	-0.1507	-0.1257	0.0317	*****	*****	*****	*****	*****	*****	
0.150	-0.1564	-0.1284	0.0169	*****	*****	*****	*****	*****	*****	
0.200	-0.1600	-0.1247	0.0030	*****	*****	*****	*****	*****	-0.3575	
0.250	*****	-0.1328	-0.0149	-0.2291	-0.3416	*****	*****	*****	*****	
0.300	-0.1781	-0.1366	-0.0263	-0.2145	-0.3750	*****	*****	*****	*****	
0.350	*****	-0.1457	-0.0407	-0.2056	-0.4842	*****	*****	*****	*****	
0.400	-0.2135	-0.1490	-0.0564	-0.1949	-0.6633	*****	*****	*****	*****	
0.450	-0.2321	-0.1623	-0.0502	-0.1953	-0.7130	*****	*****	*****	*****	
0.500	-0.2545	-0.1691	-0.0912	-0.1965	-0.6970	*****	*****	*****	*****	
0.525	*****	-0.1847	-0.1022	-0.2003	-0.6860	*****	*****	*****	*****	
0.550	-0.2751	-0.1994	-0.1131	-0.2043	-0.6315	*****	*****	*****	*****	
0.575	*****	-0.2106	-0.1165	-0.2166	-0.6012	*****	*****	*****	*****	
0.600	-0.3040	-0.2236	-0.1427	-0.2273	-0.5817	*****	*****	*****	*****	
0.625	*****	*****	-0.1491	-0.2334	-0.5828	*****	*****	*****	*****	
0.650	-0.3326	-0.2461	-0.1674	-0.2343	-0.5902	*****	*****	*****	*****	
0.675	*****	-0.2726	-0.1890	-0.2389	-0.5627	*****	*****	*****	*****	
0.700	-0.3598	-0.2977	-0.2045	-0.2438	-0.5701	*****	*****	*****	*****	
0.725	*****	-0.3261	*****	-0.2716	-0.6078	*****	*****	*****	*****	
0.750	-0.3849	-0.3585	*****	-0.3252	-0.6299	*****	*****	*****	*****	
0.775	*****	-0.3947	-0.2761	-0.3374	-0.6686	*****	*****	*****	*****	
0.800	-0.4097	-0.4347	-0.3130	-0.3356	*****	*****	*****	*****	*****	
0.825	*****	-0.4758	-0.3551	-0.3611	-0.7718	*****	*****	*****	*****	
0.850	-0.4377	-0.5175	-0.4070	-0.5065	-0.8112	*****	*****	*****	*****	
0.875	*****	-0.5637	-0.4878	-0.5815	-0.7928	*****	*****	*****	*****	
0.900	-0.4705	-0.6149	-0.6249	-0.7342	-0.7174	*****	*****	*****	*****	
0.925	*****	-0.6708	-0.8053	-0.8242	-0.6197	*****	*****	*****	*****	
0.950	-0.5321	-0.7132	-0.9726	-0.8738	-0.5433	*****	*****	*****	*****	
0.975	*****	-0.9905	-1.0815	-0.8766	-0.7793	*****	*****	*****	*****	
1.000	-0.6322	-1.0658	-0.8713	-1.2285	-1.1166	*****	*****	*****	*****	
-0.200	$C_{p,l}$	$C_{p,l}$	$C_{p,l}$	$C_{p,l}$	$C_{p,l}$	$C_{p,l}$	$C_{p,l}$	$C_{p,l}$	$C_{p,l}$	
-0.400	0.1635	0.1630	0.2062	*****	*****	-0.6313	*****	*****	*****	
-0.600	0.1543	0.1724	0.1777	0.0168	-0.7108	*****	*****	*****	*****	
-0.700	0.1695	0.1732	0.1715	0.0530	-0.6874	*****	*****	*****	*****	
-0.800	0.1899	0.1688	0.1739	0.0694	-0.6577	*****	*****	*****	*****	
-0.850	0.2193	*****	0.1717	0.0920	-0.5896	*****	*****	*****	*****	
-0.900	*****	0.2085	0.1822	0.1005	-0.5911	*****	*****	*****	*****	
-0.950	*****	0.2315	0.2033	0.1246	-0.5753	*****	*****	*****	*****	
-0.975	0.2520	0.2411	0.2267	0.1662	-0.2054	*****	*****	*****	*****	
-1.000	*****	0.2013	0.2009	0.1660	-0.0600	*****	*****	*****	*****	
	-0.6614	-0.9157	-1.1553	-1.1373	-0.9321	*****	*****	*****	*****	

Medium Radius L.E.
 Run No. = 15, Point No. = 322
 $C_N = 0.352$, $C_m = -0.0633$
 $\alpha = 8.2^\circ$, $M_\infty = 0.849$
 $R_{mac} = 96.3 \times 10^6$

Leading Edge Pressures

● starboard
 ○ port

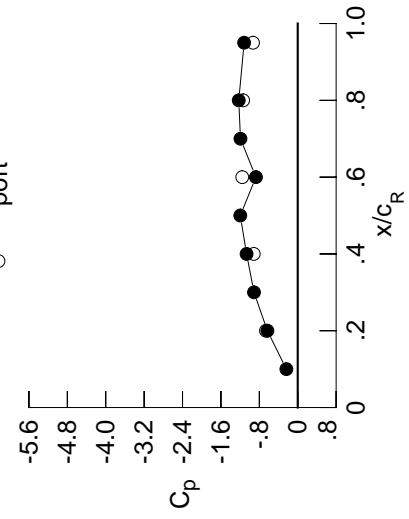

x/c_R	starb'd C_p	port C_p
0.10	-0.2371	*****
0.20	-0.6322	-0.6614
0.30	-0.9111	*****
0.40	-1.0658	-0.9157
0.50	-1.1967	*****
0.60	-0.8713	-1.1553
0.70	-1.1931	*****
0.80	-1.2285	-1.1373
0.90	*****	*****
0.95	-1.1166	-0.9321

Surface Pressures

● upper, starboard
 ○ lower, port

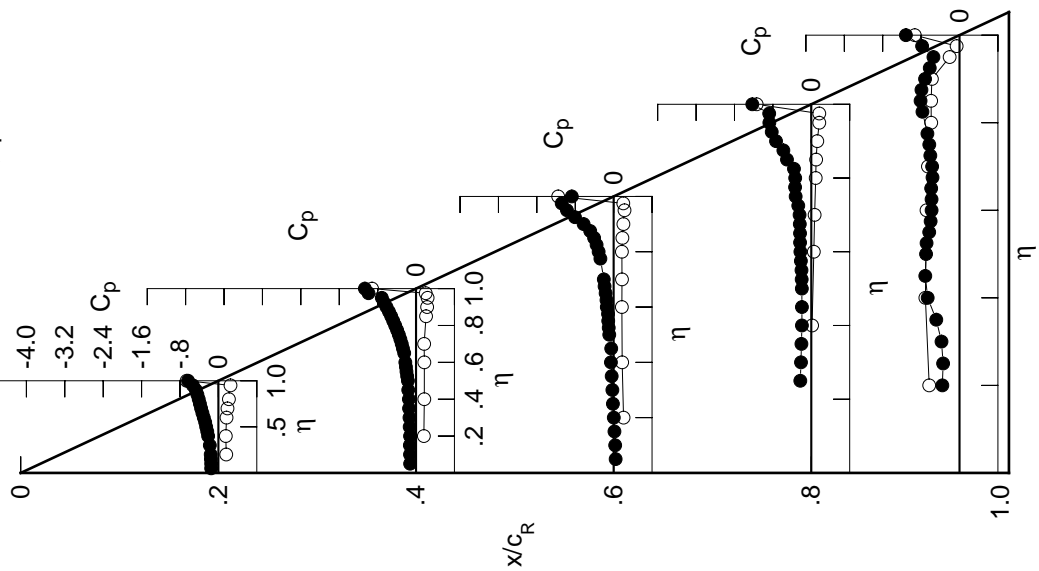
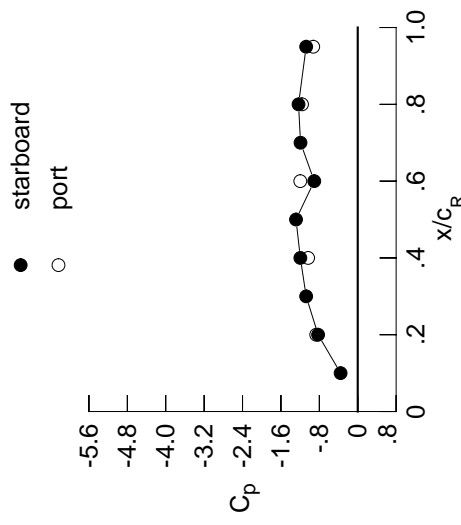

Table E9. Continued.

η	$x/c_R = .2$		$x/c_R = .4$		$x/c_R = .6$		$x/c_R = .8$		$x/c_R = .95$	
	$C_{p,u}$	$C_{p,l}$	$C_{p,u}$	$C_{p,l}$	$C_{p,u}$	$C_{p,l}$	$C_{p,u}$	$C_{p,l}$	$C_{p,u}$	$C_{p,l}$
0.050	-0.1661	-0.1453	0.0203	*****	*****	*****	*****	*****	*****	*****
0.100	-0.1699	-0.1488	0.0101	*****	*****	*****	*****	*****	*****	*****
0.150	-0.1765	-0.1514	-0.0059	*****	*****	*****	*****	*****	*****	*****
0.200	-0.1806	-0.1489	-0.0199	*****	*****	*****	*****	*****	-0.3291	*****
0.250	*****	-0.1575	-0.0388	-0.2594	-0.2594	-0.2594	-0.2594	-0.2649	*****	*****
0.300	-0.1993	-0.1625	-0.0479	-0.2415	-0.2415	-0.2415	-0.2415	-0.3056	*****	*****
0.350	*****	-0.1709	-0.0620	-0.2309	-0.2309	-0.2309	-0.2309	-0.3939	*****	*****
0.400	-0.2365	-0.1763	-0.0823	-0.2250	-0.2250	-0.2250	-0.2250	-0.4073	*****	*****
0.450	-0.2572	-0.1905	-0.0871	-0.2298	-0.2298	-0.2298	-0.2298	-0.3230	*****	*****
0.500	-0.2823	-0.2071	-0.1285	-0.2457	-0.2457	-0.2457	-0.2457	-0.2280	*****	*****
0.525	*****	-0.2251	-0.1434	-0.2430	-0.2430	-0.2430	-0.2430	-0.2984	*****	*****
0.550	-0.3061	-0.2413	-0.1607	-0.2308	-0.2308	-0.2308	-0.2308	-0.4030	*****	*****
0.575	*****	-0.2530	-0.1674	-0.2263	-0.2263	-0.2263	-0.2263	-0.6087	*****	*****
0.600	-0.3385	-0.2665	-0.1904	-0.2222	-0.2222	-0.2222	-0.2222	-0.7532	*****	*****
0.625	*****	*****	-0.1853	-0.2153	-0.2153	-0.2153	-0.2153	-0.7647	*****	*****
0.650	-0.3718	-0.2896	-0.1887	-0.2085	-0.2085	-0.2085	-0.2085	-0.7566	*****	*****
0.675	*****	-0.3140	-0.1985	-0.2018	-0.2018	-0.2018	-0.2018	-0.7233	*****	*****
0.700	-0.4042	-0.3374	-0.2012	-0.1851	-0.1851	-0.1851	-0.1851	-0.7452	*****	*****
0.725	*****	-0.3672	*****	-0.1997	-0.1997	-0.1997	-0.1997	-0.8860	*****	*****
0.750	-0.4375	-0.4017	*****	-0.3837	-0.3837	-0.3837	-0.3837	-1.0710	*****	*****
0.775	*****	-0.4401	-0.2059	-0.7619	-0.7619	-0.7619	-0.7619	-1.1304	*****	*****
0.800	-0.4696	-0.4816	-0.4450	-0.8981	-0.8981	-0.8981	-0.8981	*****	*****	*****
0.825	*****	-0.5243	-0.7541	-0.9507	-0.9507	-0.9507	-0.9507	-0.8766	*****	*****
0.850	-0.5095	-0.5681	-0.9084	-0.9168	-0.9168	-0.9168	-0.9168	-0.8314	*****	*****
0.875	*****	-0.6132	-0.9818	-0.8402	-0.8402	-0.8402	-0.8402	-0.7147	*****	*****
0.900	-0.5566	-0.6875	-0.9808	-0.7672	-0.7672	-0.7672	-0.7672	-0.6668	*****	*****
0.925	*****	-0.8202	-0.9458	-0.7160	-0.7160	-0.7160	-0.7160	-0.6588	*****	*****
0.950	-0.6391	-1.0585	-0.8901	-0.6853	-0.6853	-0.6853	-0.6853	-0.5949	*****	*****
0.975	*****	-1.2703	-0.9393	-0.6620	-0.6620	-0.6620	-0.6620	-0.6300	*****	*****
1.000	-0.8254	-1.1954	-0.9057	-1.2334	-1.2334	-1.2334	-1.2334	-1.0747	*****	*****
	$C_{p,l}$	$C_{p,l}$	$C_{p,l}$	$C_{p,l}$	$C_{p,l}$	$C_{p,l}$	$C_{p,l}$	$C_{p,l}$	$C_{p,l}$	$C_{p,l}$
-0.200	0.1903	0.1868	0.2252	*****	*****	*****	*****	-0.6267	*****	*****
-0.400	0.1830	0.1969	0.1972	0.0328	0.0328	0.0328	0.0328	-0.7027	*****	*****
-0.600	0.1998	0.1990	0.1923	0.0683	0.0683	0.0683	0.0683	-0.6771	*****	*****
-0.700	0.2210	0.1973	0.1957	0.0858	0.0858	0.0858	0.0858	-0.6477	*****	*****
-0.800	0.2475	*****	0.1963	0.1095	0.1095	0.1095	0.1095	-0.5776	*****	*****
-0.850	*****	0.2361	0.2074	0.1192	0.1192	0.1192	0.1192	-0.5775	*****	*****
-0.900	*****	0.2543	0.2263	0.1430	0.1430	0.1430	0.1430	-0.5563	*****	*****
-0.950	0.2536	0.2486	0.2391	0.1769	0.1769	0.1769	0.1769	-0.1975	*****	*****
-0.975	*****	0.1880	0.1992	0.1653	0.1653	0.1653	0.1653	-0.0594	*****	*****
-1.000	-0.8647	-1.0337	-1.1966	-1.1609	-1.1609	-1.1609	-1.1609	-0.9271	*****	*****

Medium Radius L.E.
 Run No. = 15 , Point No. = 323
 $C_N = 0.415$, $C_m = -0.0752$
 $\alpha = 9.2^\circ$, $M_\infty = 0.850$
 $R_{mac} = 96.2 \times 10^6$

Leading Edge Pressures



x/c_R	starb'd C_p	port C_p
0.10	-0.3570	*****
0.20	-0.8254	-0.8647
0.30	-1.0744	*****
0.40	-1.1954	-1.0337
0.50	-1.2860	*****
0.60	-0.9057	-1.1966
0.70	-1.1916	*****
0.80	-1.2334	-1.1609
0.90	*****	*****
0.95	-1.0747	-0.9271

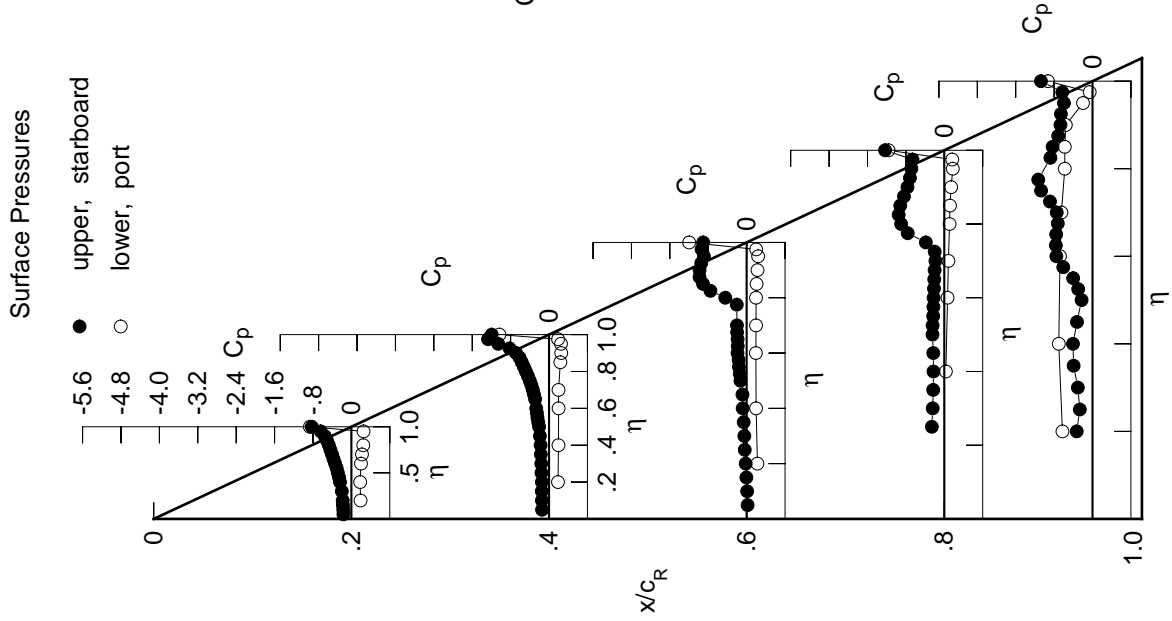

Table E9. Continued.

η	$x/c_R = .2$		$x/c_R = .4$		$x/c_R = .6$		$x/c_R = .8$		$x/c_R = .95$	
	$C_{p,u}$	$C_{p,l}$	$C_{p,u}$	$C_{p,l}$	$C_{p,u}$	$C_{p,l}$	$C_{p,u}$	$C_{p,l}$	$C_{p,u}$	$C_{p,l}$
0.050	-0.1819	-0.1731	-0.0022	*****	*****	*****	*****	*****	*****	*****
0.100	-0.1883	-0.1777	-0.0129	*****	*****	*****	*****	*****	*****	*****
0.150	-0.1971	-0.1804	-0.0295	*****	*****	*****	*****	*****	*****	*****
0.200	-0.2020	-0.1788	-0.0441	*****	*****	*****	*****	*****	*****	-0.2917
0.250	*****	-0.1883	-0.0591	-0.2807	-0.2757	*****	*****	*****	*****	*****
0.300	-0.2226	-0.1921	-0.0701	-0.2633	-0.3399	*****	*****	*****	*****	*****
0.350	*****	-0.2007	-0.0948	-0.2569	-0.3358	*****	*****	*****	*****	*****
0.400	-0.2612	-0.2147	-0.1186	-0.2634	-0.2722	*****	*****	*****	*****	*****
0.450	-0.2836	-0.2372	-0.1325	-0.2493	-0.3257	*****	*****	*****	*****	*****
0.500	-0.3107	-0.2547	-0.1634	-0.2349	-0.5622	*****	*****	*****	*****	*****
0.525	*****	-0.2707	-0.1638	-0.2325	-0.7099	*****	*****	*****	*****	*****
0.550	-0.3378	-0.2893	-0.1621	-0.2253	-0.7373	*****	*****	*****	*****	*****
0.575	*****	-0.3010	-0.1522	-0.2231	-0.7429	*****	*****	*****	*****	*****
0.600	-0.3733	-0.3104	-0.1687	-0.2180	-0.7202	*****	*****	*****	*****	*****
0.625	*****	*****	-0.1655	-0.2080	-0.6940	*****	*****	*****	*****	*****
0.650	-0.4116	-0.3261	-0.1644	-0.2098	-0.7042	*****	*****	*****	*****	*****
0.675	*****	-0.3449	-0.1650	-0.2602	-0.7604	*****	*****	*****	*****	*****
0.700	-0.4499	-0.3627	-0.1507	-0.4121	-0.9109	*****	*****	*****	*****	*****
0.725	*****	-0.3913	*****	-0.6768	-1.0644	*****	*****	*****	*****	*****
0.750	-0.4903	-0.4260	*****	-0.9004	-1.1262	*****	*****	*****	*****	*****
0.775	*****	-0.4692	-0.9624	-1.0288	-1.0681	*****	*****	*****	*****	*****
0.800	-0.5401	-0.5389	-1.0593	-1.0174	*****	*****	*****	*****	*****	*****
0.825	*****	-0.6733	-1.0545	-1.0160	-0.7186	*****	*****	*****	*****	*****
0.850	-0.5812	-0.8511	-1.0186	-0.9216	-0.6324	*****	*****	*****	*****	*****
0.875	*****	-0.9908	-0.9913	-0.7872	-0.6095	*****	*****	*****	*****	*****
0.900	-0.6416	-1.0866	-0.9303	-0.7360	-0.5948	*****	*****	*****	*****	*****
0.925	*****	-1.1346	-0.8634	-0.6869	-0.5973	*****	*****	*****	*****	*****
0.950	-0.7469	-1.1538	-0.8192	-0.6667	-0.5498	*****	*****	*****	*****	*****
0.975	*****	-1.1700	-0.7965	-0.6367	-0.5496	*****	*****	*****	*****	*****
1.000	-0.9751	-1.2835	-0.9013	-1.2463	-0.8311	*****	*****	*****	*****	*****
-0.200	$C_{p,l}$	0.2192	0.2122	0.2425	*****	*****	*****	*****	*****	-0.6212
-0.400		0.2127	0.2222	0.2155	0.0479	-0.6965	*****	*****	*****	*****
-0.600		0.2312	0.2259	0.2114	0.0826	-0.6704	*****	*****	*****	*****
-0.700		0.2519	0.2254	0.2164	0.1020	-0.6399	*****	*****	*****	*****
-0.800		0.2758	*****	0.2172	0.1254	-0.5674	*****	*****	*****	*****
-0.850	*****	0.2628	0.2278	0.1355	-0.5652	*****	*****	*****	*****	*****
-0.900	*****	0.2753	0.2437	0.1587	-0.5364	*****	*****	*****	*****	*****
-0.950	0.2524	0.2562	0.2446	0.1846	-0.1802	*****	*****	*****	*****	*****
-0.975	*****	0.1768	0.1901	0.1594	-0.0390	*****	*****	*****	*****	*****
-1.000	-1.0440	-1.1052	-1.2460	-1.2005	-0.6280	*****	*****	*****	*****	*****

Medium Radius L.E.
 Run No. = 15, Point No. = 324
 $C_N = 0.471$, $C_m = -0.0820$
 $\alpha = 10.3^\circ$, $M_\infty = 0.848$
 $R_{mac} = 95.8 \times 10^6$

Leading Edge Pressures

● starboard
 ○ port

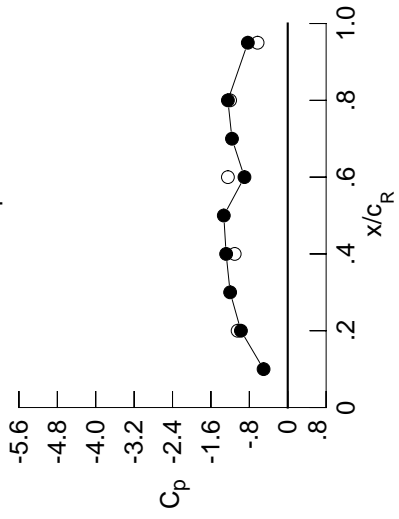

x/c_R	starb'd C_p	port C_p
0.10	-0.5029	*****
0.20	-0.9751	-1.0440
0.30	-1.1998	*****
0.40	-1.2835	-1.1052
0.50	-1.3322	*****
0.60	-0.9013	-1.2460
0.70	-1.1618	*****
0.80	-1.2463	-1.2005
0.90	*****	*****
0.95	-0.8311	-0.6280

Surface Pressures

● upper, starboard
 ○ lower, port

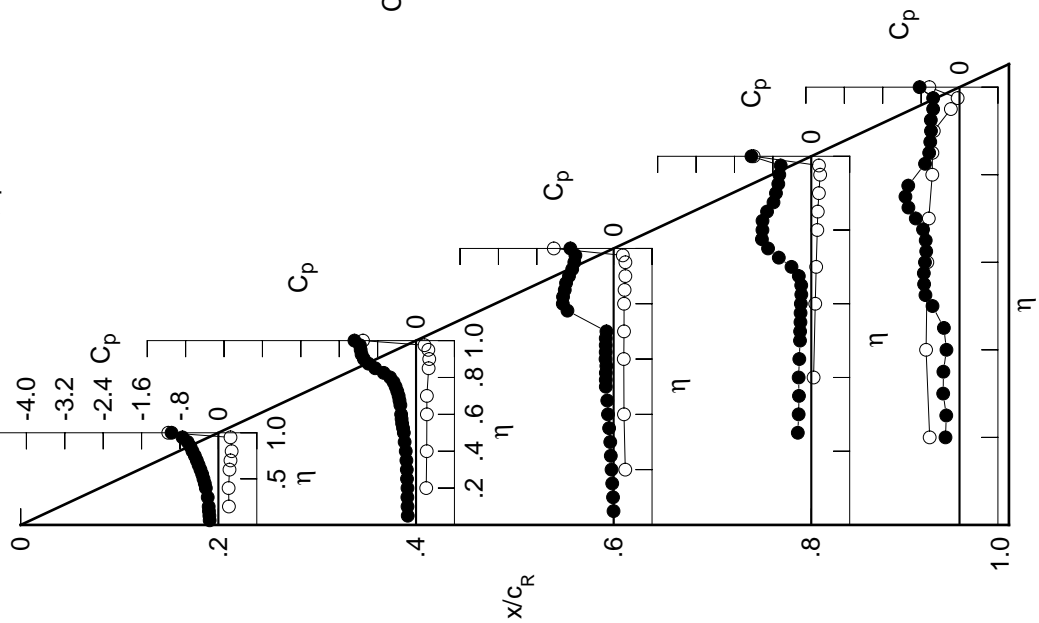

Table E9. Continued.

η	$x/c_R = .2$		$x/c_R = .4$		$x/c_R = .6$		$x/c_R = .8$		$x/c_R = .95$	
	$C_{p,u}$	$C_{p,u}$	$C_{p,u}$	$C_{p,u}$	$C_{p,u}$	$C_{p,u}$	$C_{p,u}$	$C_{p,u}$	$C_{p,u}$	$C_{p,u}$
0.050	-0.1986	-0.2019	-0.0245	*****	*****	*****	*****	*****	*****	*****
0.100	-0.2037	-0.2055	-0.0360	*****	*****	*****	*****	*****	*****	*****
0.150	-0.2178	-0.2101	-0.0537	*****	*****	*****	*****	*****	*****	*****
0.200	-0.2237	-0.2089	-0.0625	*****	*****	*****	*****	*****	*****	*****
0.250	*****	-0.2144	-0.0846	-0.3062	-0.3498	*****	*****	*****	*****	*****
0.300	-0.2477	-0.2226	-0.0995	-0.2910	-0.4204	*****	*****	*****	*****	*****
0.350	*****	-0.2403	-0.1247	-0.2906	-0.4137	*****	*****	*****	*****	*****
0.400	-0.2881	-0.2571	-0.1515	-0.2902	-0.4045	*****	*****	*****	*****	*****
0.450	-0.3126	-0.2821	-0.1663	-0.2722	-0.4841	*****	*****	*****	*****	*****
0.500	-0.3415	-0.2900	-0.1856	-0.2581	-0.6753	*****	*****	*****	*****	*****
0.525	*****	-0.2990	-0.1834	-0.2547	-0.7119	*****	*****	*****	*****	*****
0.550	-0.3710	-0.3086	-0.1798	-0.2459	-0.6991	*****	*****	*****	*****	*****
0.575	*****	-0.3154	-0.1660	-0.2459	-0.6956	*****	*****	*****	*****	*****
0.600	-0.4085	-0.3322	-0.1792	-0.2496	-0.6818	*****	*****	*****	*****	*****
0.625	*****	*****	-0.1670	-0.2673	-0.6979	*****	*****	*****	*****	*****
0.650	-0.4513	-0.4074	-0.1715	-0.3341	-0.7890	*****	*****	*****	*****	*****
0.675	*****	-0.4275	-0.2243	-0.4960	-0.9259	*****	*****	*****	*****	*****
0.700	-0.4954	-0.4230	-0.3936	-0.7362	-1.0892	*****	*****	*****	*****	*****
0.725	*****	-0.4247	*****	-0.9605	-1.2014	*****	*****	*****	*****	*****
0.750	-0.5512	-0.4248	*****	-1.0795	-1.1780	*****	*****	*****	*****	*****
0.775	*****	-0.4618	-1.1033	-1.1246	-0.8790	*****	*****	*****	*****	*****
0.800	-0.5934	-0.6977	-1.0727	-1.0857	*****	*****	*****	*****	*****	*****
0.825	*****	-1.0522	-1.0520	-1.0394	-0.6173	*****	*****	*****	*****	*****
0.850	-0.6389	-1.1473	-1.0096	-0.8849	-0.5595	*****	*****	*****	*****	*****
0.875	*****	-1.1800	-0.9825	-0.7996	-0.5482	*****	*****	*****	*****	*****
0.900	-0.7122	-1.1892	-0.9355	-0.7760	-0.5458	*****	*****	*****	*****	*****
0.925	*****	-1.2033	-0.8801	-0.7061	-0.5555	*****	*****	*****	*****	*****
0.950	-1.1075	-1.1913	-0.8368	-0.6760	-0.5174	*****	*****	*****	*****	*****
0.975	*****	-1.1549	-0.8049	-0.6372	-0.4734	*****	*****	*****	*****	*****
1.000	-1.0883	-1.3467	-0.8876	-1.0934	-0.6491	*****	*****	*****	*****	*****
-0.200	$C_{p,l}$	$C_{p,l}$	$C_{p,l}$	$C_{p,l}$	$C_{p,l}$	$C_{p,l}$	$C_{p,l}$	$C_{p,l}$	$C_{p,l}$	$C_{p,l}$
-0.400	0.2493	0.2376	0.2620	*****	-0.6077	*****	*****	*****	*****	*****
-0.600	0.2441	0.2479	0.2359	0.0647	-0.6826	*****	*****	*****	*****	*****
-0.700	0.2635	0.2518	0.2327	0.0997	-0.6584	*****	*****	*****	*****	*****
-0.800	0.2824	0.2520	0.2376	0.1187	-0.6272	*****	*****	*****	*****	*****
-0.850	0.3028	*****	0.2390	0.1426	-0.5542	*****	*****	*****	*****	*****
-0.900	*****	0.2850	0.2490	0.1530	-0.5501	*****	*****	*****	*****	*****
-0.950	*****	0.2914	0.2614	0.1745	-0.5175	*****	*****	*****	*****	*****
-0.975	0.2509	0.2574	0.2501	0.1911	-0.1748	*****	*****	*****	*****	*****
-1.000	0.2509	0.1585	0.1813	0.1532	-0.0450	*****	*****	*****	*****	*****
	-1.1217	-1.1552	-1.1938	-1.1545	-0.6506	*****	*****	*****	*****	*****

Medium Radius L.E.
 Run No. = 15 , Point No. = 325
 $C_N = 0.534$, $C_m = -0.0931$
 $\alpha = 11.4^\circ$, $M_\infty = 0.849$
 $R_{mac} = 95.8 \times 10^6$

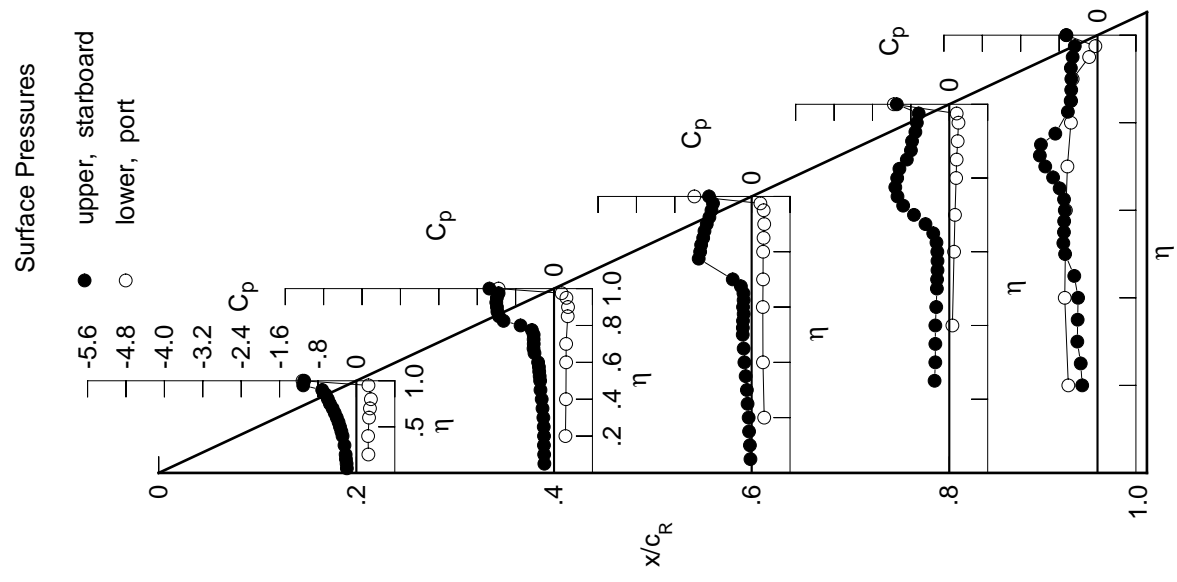
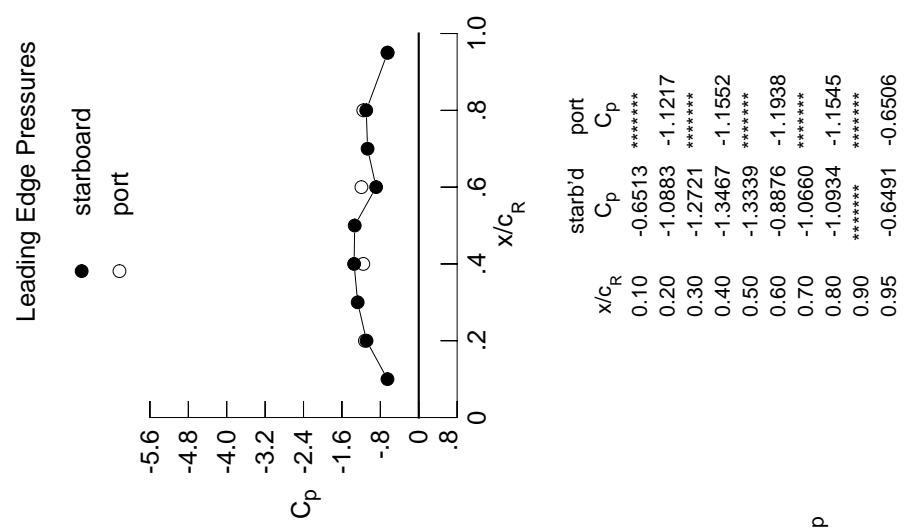

Table E9. Continued.

η	x/c_R .2		x/c_R .4		x/c_R .6		x/c_R .8		x/c_R .95	
	$C_{p,u}$	$C_{p,u}$	$C_{p,u}$	$C_{p,u}$	$C_{p,u}$	$C_{p,u}$	$C_{p,u}$	$C_{p,u}$	$C_{p,u}$	$C_{p,u}$
0.050	-0.2204	-0.2403	-0.0485	*****	*****	*****	*****	*****	*****	*****
0.100	-0.2232	-0.2417	-0.0591	*****	*****	*****	*****	*****	*****	*****
0.150	-0.2417	-0.2459	-0.0765	*****	*****	*****	*****	*****	*****	*****
0.200	-0.2504	-0.2435	-0.0869	*****	*****	*****	*****	*****	*****	*****
0.250	*****	-0.2515	-0.1085	-0.3313	-0.3914	*****	*****	*****	*****	*****
0.300	-0.2782	-0.2630	-0.1298	-0.3228	-0.3992	*****	*****	*****	*****	*****
0.350	*****	-0.2885	-0.1666	-0.3169	-0.3621	*****	*****	*****	*****	*****
0.400	-0.3240	-0.3013	-0.1672	-0.2935	-0.4411	*****	*****	*****	*****	*****
0.450	-0.3479	-0.3231	-0.1459	-0.2808	-0.6533	*****	*****	*****	*****	*****
0.500	-0.3735	-0.3360	-0.1669	-0.2667	-0.6948	*****	*****	*****	*****	*****
0.525	*****	-0.3340	-0.1644	-0.2639	-0.6858	*****	*****	*****	*****	*****
0.550	-0.4032	-0.3360	-0.1601	-0.2606	-0.6730	*****	*****	*****	*****	*****
0.575	*****	-0.3332	-0.1426	-0.2735	-0.6858	*****	*****	*****	*****	*****
0.600	-0.4427	-0.3282	-0.1868	-0.3092	-0.7179	*****	*****	*****	*****	*****
0.625	*****	*****	-0.2437	-0.3925	-0.8008	*****	*****	*****	*****	*****
0.650	-0.4876	-0.2941	-0.4502	-0.5575	-0.9542	*****	*****	*****	*****	*****
0.675	*****	-0.2889	-0.7431	-0.7958	-1.1077	*****	*****	*****	*****	*****
0.700	-0.5417	-0.3551	-0.9574	-1.0241	-1.2413	*****	*****	*****	*****	*****
0.725	*****	-0.7716	*****	-1.1924	-0.9343	*****	*****	*****	*****	*****
0.750	-0.5867	-1.1295	*****	-1.2706	-0.8322	*****	*****	*****	*****	*****
0.775	*****	-1.2437	-1.1912	-1.2178	-0.7124	*****	*****	*****	*****	*****
0.800	-0.6280	-1.2598	-1.1291	-0.9975	*****	*****	*****	*****	*****	*****
0.825	*****	-1.2189	-1.0938	-0.8876	-0.5642	*****	*****	*****	*****	*****
0.850	-0.7705	-1.2043	-1.0346	-0.8234	-0.5261	*****	*****	*****	*****	*****
0.875	*****	-1.1884	-0.9700	-0.8186	-0.5349	*****	*****	*****	*****	*****
0.900	-1.0532	-1.1406	-0.9021	-0.7827	-0.5383	*****	*****	*****	*****	*****
0.925	*****	-1.1267	-0.8574	-0.7085	-0.5597	*****	*****	*****	*****	*****
0.950	-1.2657	-1.0952	-0.8163	-0.7035	-0.5119	*****	*****	*****	*****	*****
0.975	*****	-1.0639	-0.7887	-0.6541	-0.4460	*****	*****	*****	*****	*****
1.000	-1.1843	-1.3659	-0.8607	-1.0121	-0.5833	*****	*****	*****	*****	*****
-0.200	$C_{p,l}$	$C_{p,l}$	$C_{p,l}$	$C_{p,l}$	$C_{p,l}$	$C_{p,l}$	$C_{p,l}$	$C_{p,l}$	$C_{p,l}$	$C_{p,l}$
-0.400	0.2776	0.2606	0.2787	*****	*****	*****	*****	*****	*****	*****
-0.600	0.2739	0.2708	0.2522	0.0781	-0.6736	*****	*****	*****	*****	*****
-0.700	0.2934	0.2759	0.2489	0.1130	-0.6491	*****	*****	*****	*****	*****
-0.800	0.3112	0.2774	0.2552	0.1323	-0.6175	*****	*****	*****	*****	*****
-0.850	0.3275	*****	0.2566	0.1560	-0.5430	*****	*****	*****	*****	*****
-0.900	*****	0.3069	0.2657	0.1662	-0.5369	*****	*****	*****	*****	*****
-0.950	*****	0.3074	0.2743	0.1864	-0.4996	*****	*****	*****	*****	*****
-0.975	0.2478	0.2611	0.2514	0.1942	-0.1663	*****	*****	*****	*****	*****
-1.000	*****	0.1478	0.1695	0.1448	-0.0435	*****	*****	*****	*****	*****
	-1.1809	-1.1655	-1.0820	-1.0615	-0.5641	*****	*****	*****	*****	*****

Medium Radius L.E.
 Run No. = 15 , Point No. = 326
 $C_N = 0.594$, $C_m = -0.1010$
 $\alpha = 12.5^\circ$, $M_\infty = 0.849$
 $R_{mac} = 95.5 \times 10^6$

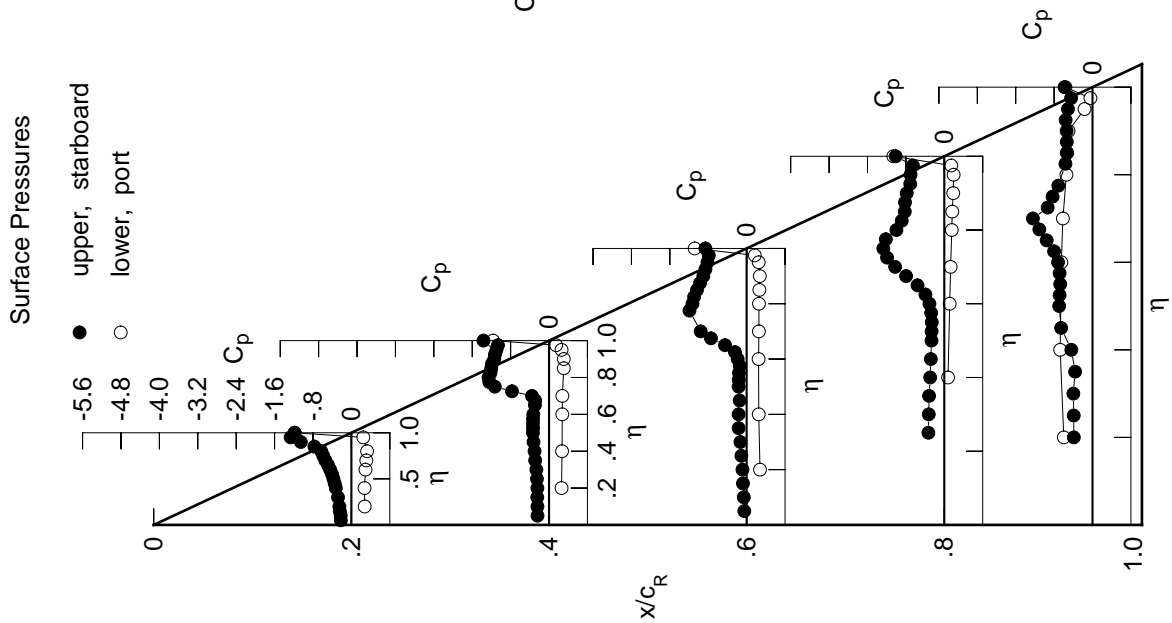
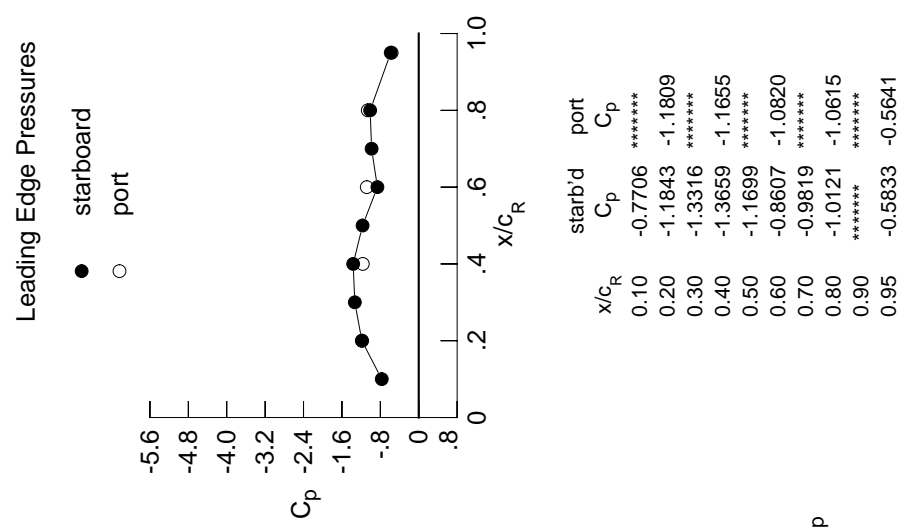

Table E9. Continued.

η	$x/c_R = .2$		$x/c_R = .4$		$x/c_R = .6$		$x/c_R = .8$		$x/c_R = .95$	
	$C_{p,u}$	$C_{p,u}$	$C_{p,u}$	$C_{p,u}$	$C_{p,u}$	$C_{p,u}$	$C_{p,u}$	$C_{p,u}$	$C_{p,u}$	$C_{p,u}$
0.050	-0.2456	-0.2803	-0.0709	*****	*****	*****	*****	*****	*****	*****
0.100	-0.2449	-0.2801	-0.0816	*****	*****	*****	*****	*****	*****	*****
0.150	-0.2640	-0.2838	-0.0967	*****	*****	*****	*****	*****	*****	*****
0.200	-0.2772	-0.2791	-0.1115	*****	*****	*****	*****	*****	*****	-0.4058
0.250	*****	-0.2900	-0.1323	-0.3576	-0.3973	*****	*****	*****	*****	-0.3973
0.300	-0.3194	-0.3122	-0.1548	-0.3464	-0.4359	*****	*****	*****	*****	-0.4359
0.350	*****	-0.3369	-0.1939	-0.3407	-0.4561	*****	*****	*****	*****	-0.4561
0.400	-0.3599	-0.3397	-0.2027	-0.3247	-0.5249	*****	*****	*****	*****	-0.5249
0.450	-0.3786	-0.3754	-0.1899	-0.3137	-0.6376	*****	*****	*****	*****	-0.6376
0.500	-0.4047	-0.4006	-0.2067	-0.3042	-0.6801	*****	*****	*****	*****	-0.6801
0.525	*****	-0.3955	-0.2089	-0.3088	-0.6889	*****	*****	*****	*****	-0.6889
0.550	-0.4348	-0.3981	-0.2157	-0.3214	-0.6982	*****	*****	*****	*****	-0.6982
0.575	*****	-0.4008	-0.2209	-0.3620	-0.7500	*****	*****	*****	*****	-0.7500
0.600	-0.4776	-0.3972	-0.3099	-0.4392	-0.8253	*****	*****	*****	*****	-0.8253
0.625	*****	*****	-0.4231	-0.5724	-0.9448	*****	*****	*****	*****	-0.9448
0.650	-0.5181	-0.3712	-0.6688	-0.7678	-1.1024	*****	*****	*****	*****	-1.1024
0.675	*****	-0.4147	-0.9458	-0.9915	-1.1738	*****	*****	*****	*****	-1.1738
0.700	-0.5608	-0.6302	-1.1413	-1.1814	-0.8020	*****	*****	*****	*****	-0.8020
0.725	*****	-1.0471	*****	-1.3204	-0.7509	*****	*****	*****	*****	-0.7509
0.750	-0.6192	-1.3038	*****	-1.2570	-0.6762	*****	*****	*****	*****	-0.6762
0.775	*****	-1.3701	-1.2891	-1.0433	-0.5988	*****	*****	*****	*****	-0.5988
0.800	-0.8523	-1.3502	-1.2227	-0.9545	*****	*****	*****	*****	*****	*****
0.825	*****	-1.3114	-1.1483	-0.8908	-0.5352	*****	*****	*****	*****	-0.5352
0.850	-1.1302	-1.2831	-1.0437	-0.8679	-0.5043	*****	*****	*****	*****	-0.5043
0.875	*****	-1.2591	-0.9699	-0.8531	-0.5191	*****	*****	*****	*****	-0.5191
0.900	-1.2505	-1.1935	-0.9311	-0.8056	-0.5293	*****	*****	*****	*****	-0.5293
0.925	*****	-1.1550	-0.8834	-0.7467	-0.5455	*****	*****	*****	*****	-0.5455
0.950	-1.2987	-1.1249	-0.8282	-0.7520	-0.4880	*****	*****	*****	*****	-0.4880
0.975	*****	-1.0891	-0.7986	-0.6852	-0.4164	*****	*****	*****	*****	-0.4164
1.000	-1.2576	-1.3554	-0.8407	-1.0005	-0.5150	*****	*****	*****	*****	-0.5150
-0.200	$C_{p,l}$	$C_{p,l}$	$C_{p,l}$	$C_{p,l}$	$C_{p,l}$	$C_{p,l}$	$C_{p,l}$	$C_{p,l}$	$C_{p,l}$	$C_{p,l}$
-0.400	0.3096	0.2877	0.2980	*****	-0.5864	*****	*****	*****	*****	-0.5864
-0.600	0.3067	0.2978	0.2729	0.0953	-0.6637	*****	*****	*****	*****	-0.6637
-0.700	0.3263	0.3026	0.2702	0.1293	-0.6404	*****	*****	*****	*****	-0.6404
-0.800	0.3422	0.3038	0.2764	0.1485	-0.6076	*****	*****	*****	*****	-0.6076
-0.850	0.3541	*****	0.2769	0.1722	-0.5317	*****	*****	*****	*****	-0.5317
-0.900	*****	0.3282	0.2843	0.1811	-0.5227	*****	*****	*****	*****	-0.5227
-0.950	*****	0.3228	0.2883	0.1986	-0.4813	*****	*****	*****	*****	-0.4813
-0.975	0.2468	0.2633	0.2535	0.1958	-0.1568	*****	*****	*****	*****	-0.1568
-1.000	*****	0.1346	0.1582	0.1324	-0.0446	*****	*****	*****	*****	-0.0446
-1.000	-1.2268	-1.1396	-0.9940	-0.9981	-0.5268	*****	*****	*****	*****	-0.5268

Medium Radius L.E.

Run No. = 15, Point No. = 327

$C_N = 0.650$, $C_m = -0.1069$

$\alpha = 13.5^\circ$, $M_\infty = 0.849$

$R_{mac} = 95.5 \times 10^6$

Leading Edge Pressures

● starboard
○ port

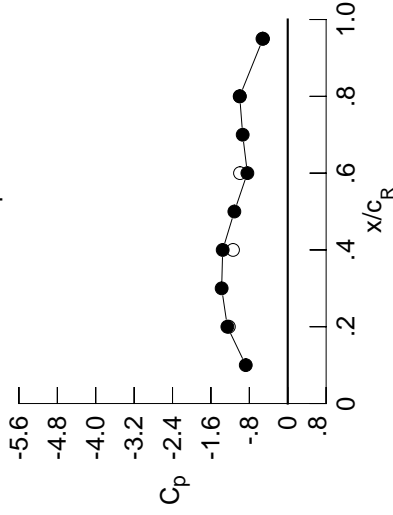

x/c_R	starb'd C_p	port C_p
0.10	-0.8748	*****
0.20	-1.2576	-1.2268
0.30	-1.3765	*****
0.40	-1.3554	-1.1396
0.50	-1.1120	*****
0.60	-0.8407	-0.9940
0.70	-0.9386	*****
0.80	-1.0005	-0.9981
0.90	*****	*****
0.95	-0.5150	-0.5268

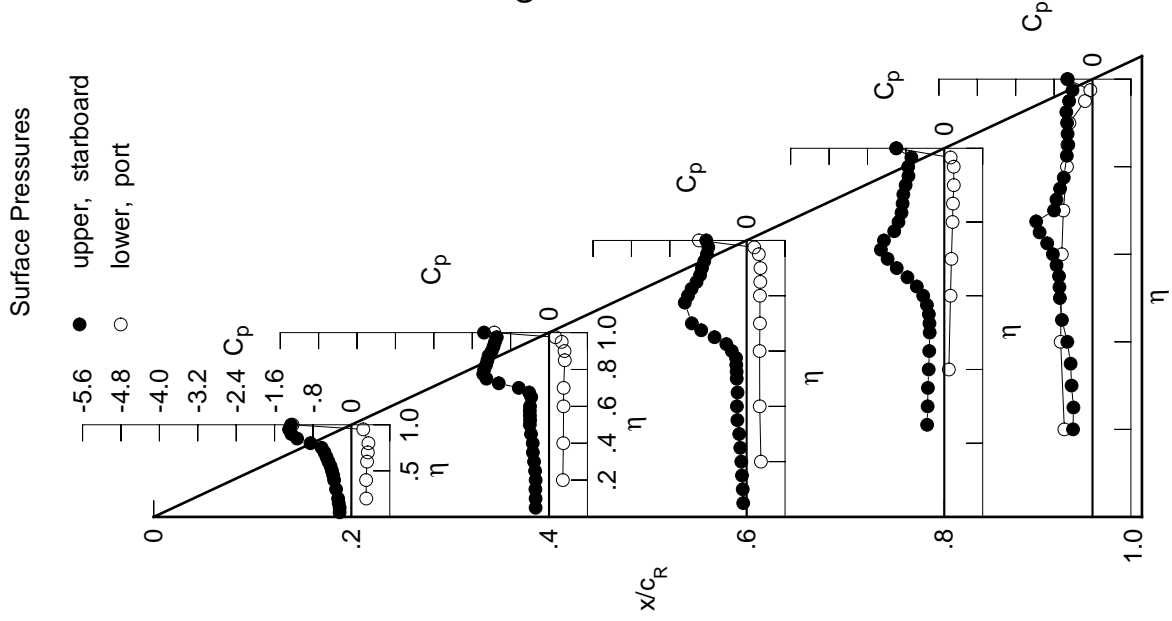
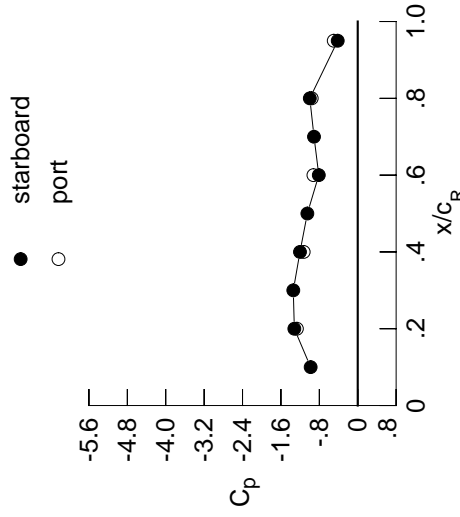

Table E9. Continued.

η	$x/c_R = 0.2$		$x/c_R = 0.4$		$x/c_R = 0.6$		$x/c_R = 0.8$		$x/c_R = 0.95$	
	$C_{p,u}$	$C_{p,u}$	$C_{p,u}$	$C_{p,u}$	$C_{p,u}$	$C_{p,u}$	$C_{p,u}$	$C_{p,u}$	$C_{p,u}$	$C_{p,u}$
0.050	-0.2726	-0.3202	-0.0900	*****	*****	*****	*****	*****	*****	*****
0.100	-0.2681	-0.3217	-0.1005	*****	*****	*****	*****	*****	*****	*****
0.150	-0.2842	-0.3210	-0.1167	*****	*****	*****	*****	*****	*****	*****
0.200	-0.2991	-0.3194	-0.1318	*****	*****	*****	*****	*****	*****	*****
0.250	*****	-0.3439	-0.1686	-0.3841	-0.5131	*****	*****	*****	*****	-0.6090
0.300	-0.3648	-0.3701	-0.1688	-0.3664	-0.3803	*****	*****	*****	*****	*****
0.350	*****	-0.3581	-0.1774	-0.3498	-0.4572	*****	*****	*****	*****	*****
0.400	-0.3855	-0.3510	-0.1852	-0.3326	-0.6518	*****	*****	*****	*****	*****
0.450	-0.3993	-0.3518	-0.1656	-0.3254	-0.7085	*****	*****	*****	*****	*****
0.500	-0.4245	-0.3399	-0.2164	-0.3345	-0.7181	*****	*****	*****	*****	*****
0.525	*****	-0.3427	-0.2432	-0.3588	-0.7430	*****	*****	*****	*****	*****
0.550	-0.4499	-0.3459	-0.3020	-0.4057	-0.7858	*****	*****	*****	*****	*****
0.575	*****	-0.3678	-0.3915	-0.4969	-0.8753	*****	*****	*****	*****	*****
0.600	-0.4798	-0.4572	-0.6240	-0.6322	-0.9768	*****	*****	*****	*****	*****
0.625	*****	*****	-0.8510	-0.8110	-1.0996	*****	*****	*****	*****	*****
0.650	-0.5060	-1.0372	-1.0922	-1.0110	-0.9546	*****	*****	*****	*****	*****
0.675	*****	-1.2816	-1.2836	-1.1996	-0.7093	*****	*****	*****	*****	*****
0.700	-0.6337	-1.3949	-1.3831	-1.2846	-0.6437	*****	*****	*****	*****	*****
0.725	*****	-1.3755	*****	-1.0153	-0.5580	*****	*****	*****	*****	*****
0.750	-0.9756	-1.3059	*****	-0.9660	-0.5075	*****	*****	*****	*****	*****
0.775	*****	-1.2869	-1.2966	-0.9671	-0.4865	*****	*****	*****	*****	*****
0.800	-1.1968	-1.2338	-1.1753	-0.9980	*****	*****	*****	*****	*****	*****
0.825	*****	-1.2081	-1.0523	-1.0205	-0.4759	*****	*****	*****	*****	*****
0.850	-1.3004	-1.2007	-0.9920	-1.0239	-0.4605	*****	*****	*****	*****	*****
0.875	*****	-1.1763	-0.9830	-0.9017	-0.4757	*****	*****	*****	*****	*****
0.900	-1.3041	-1.1210	-0.9507	-0.8089	-0.4879	*****	*****	*****	*****	*****
0.925	*****	-1.0829	-0.8572	-0.7816	-0.4856	*****	*****	*****	*****	*****
0.950	-1.2832	-1.0461	-0.8032	-0.7824	-0.4183	*****	*****	*****	*****	*****
0.975	*****	-1.0266	-0.7810	-0.7140	-0.3522	*****	*****	*****	*****	*****
1.000	-1.3207	-1.2031	-0.8109	-0.9982	-0.4167	*****	*****	*****	*****	*****
-0.200	$C_{p,l}$	$C_{p,l}$	$C_{p,l}$	$C_{p,l}$	$C_{p,l}$	$C_{p,l}$	$C_{p,l}$	$C_{p,l}$	$C_{p,l}$	$C_{p,l}$
-0.400	0.3408	0.3124	0.3155	*****	-0.5773	*****	*****	*****	*****	*****
-0.600	0.3381	0.3227	0.2907	0.1097	-0.6574	*****	*****	*****	*****	*****
-0.700	0.3570	0.3270	0.2882	0.1425	-0.6345	*****	*****	*****	*****	*****
-0.800	0.3707	0.3282	0.2943	0.1621	-0.5990	*****	*****	*****	*****	*****
-0.850	0.3773	*****	0.2940	0.1854	-0.5227	*****	*****	*****	*****	*****
-0.900	*****	0.3475	0.2997	0.1939	-0.5102	*****	*****	*****	*****	*****
-0.950	*****	0.3349	0.2991	0.2088	-0.4657	*****	*****	*****	*****	*****
-0.975	*****	0.2429	0.2619	0.2517	0.1953	-0.1498	*****	*****	*****	*****
-1.000	*****	0.1172	0.1431	0.1182	-0.0472	*****	*****	*****	*****	*****
-1.000	-1.2671	-1.1257	-0.9235	-0.9583	-0.5004	*****	*****	*****	*****	*****

Medium Radius L.E.
 Run No. = 15, Point No. = 328
 $C_N = 0.702$, $C_m = -0.1093$
 $\alpha = 14.6^\circ$, $M_\infty = 0.847$
 $R_{mac} = 95.7 \times 10^6$

Leading Edge Pressures



x/c_R	starb'd C_p	port C_p
0.10	-0.9810	*****
0.20	-1.3207	-1.2671
0.30	-1.3425	*****
0.40	-1.2031	-1.1257
0.50	-1.0496	*****
0.60	-0.8109	-0.9235
0.70	-0.9108	*****
0.80	-0.9982	-0.9583
0.90	*****	*****
0.95	-0.4167	-0.5004

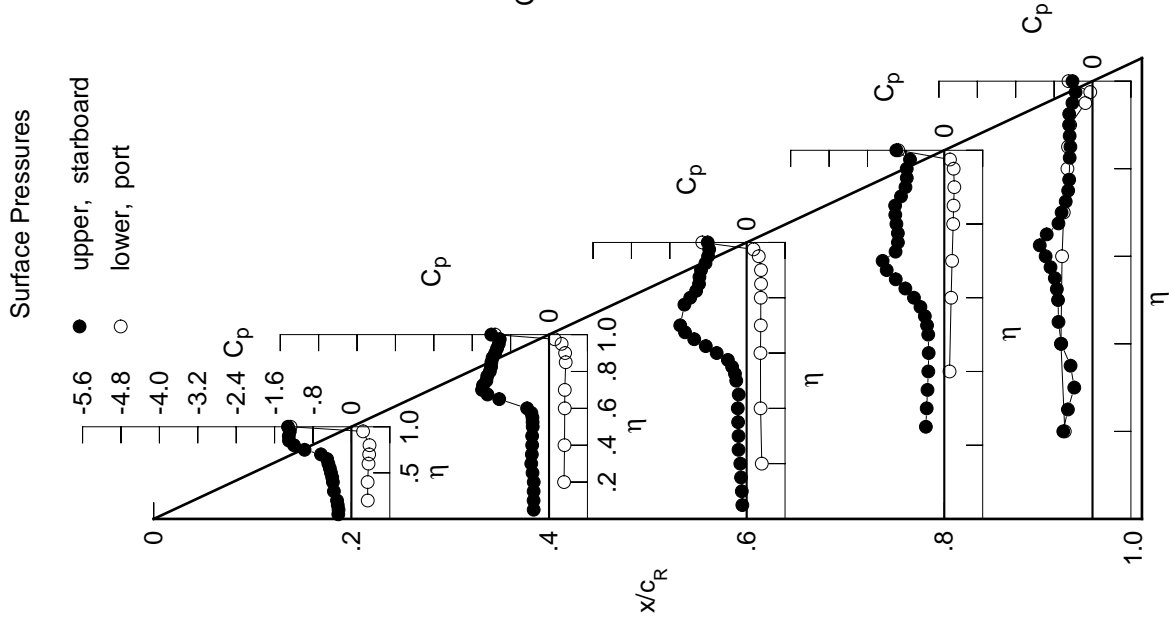
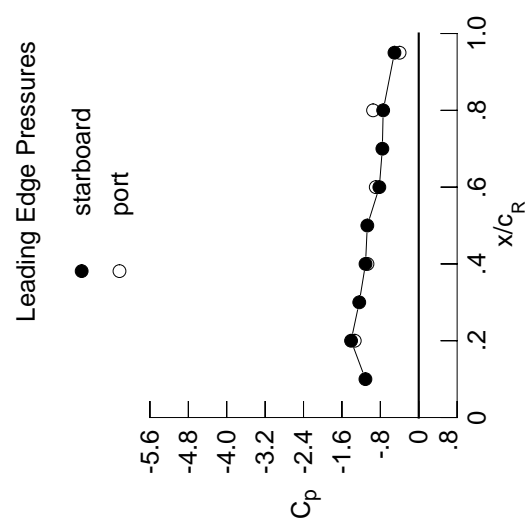

Table E9. Continued.

x/c_R	x/c_R	x/c_R	x/c_R	x/c_R	x/c_R	x/c_R	x/c_R	x/c_R	x/c_R
.2	.4	.6	.8	.95	η	$C_{p,u}$	$C_{p,u}$	$C_{p,u}$	$C_{p,u}$
0.050	-0.3274	-0.3872	-0.1048	*****	0.050	-0.3274	-0.3872	-0.1048	*****
0.100	-0.3179	-0.3838	-0.1167	*****	0.100	-0.3179	-0.3838	-0.1167	*****
0.150	-0.3314	-0.3838	-0.1281	*****	0.150	-0.3314	-0.3838	-0.1281	*****
0.200	-0.3529	-0.3950	-0.1546	*****	0.200	-0.3529	-0.3950	-0.1546	*****
0.250	*****	-0.4063	-0.1712	-0.2663	0.250	*****	-0.4063	-0.1712	-0.2663
0.300	-0.4071	-0.4025	-0.1749	-0.2371	0.300	-0.4071	-0.4025	-0.1749	-0.2371
0.350	*****	-0.4036	-0.1900	-0.2210	0.350	*****	-0.4036	-0.1900	-0.2210
0.400	-0.4079	-0.4010	-0.2084	-0.1899	0.400	-0.4079	-0.4010	-0.2084	-0.1899
0.450	-0.4293	-0.4084	-0.2201	-0.1977	0.450	-0.4293	-0.4084	-0.2201	-0.1977
0.500	-0.4468	-0.4366	-0.3626	-0.2539	0.500	-0.4468	-0.4366	-0.3626	-0.2539
0.525	*****	-0.5066	-0.4748	-0.3211	0.525	*****	-0.5066	-0.4748	-0.3211
0.550	-0.4316	-0.6238	-0.6322	-0.4223	0.550	-0.4316	-0.6238	-0.6322	-0.4223
0.575	*****	-0.8170	-0.8080	-0.5662	0.575	*****	-0.8170	-0.8080	-0.5662
0.600	-0.4793	-1.0347	-1.0435	-0.7343	0.600	-0.4793	-1.0347	-1.0435	-0.7343
0.625	*****	*****	-1.2098	-0.8906	0.625	*****	*****	-1.2098	-0.8906
0.650	-1.1572	-1.4271	-1.3539	-0.9510	0.650	-1.1572	-1.4271	-1.3539	-0.9510
0.675	*****	-1.5362	-1.4747	-0.7068	0.675	*****	-1.5362	-1.4747	-0.7068
0.700	-1.3516	-1.5998	-1.4589	-0.6455	0.700	-1.3516	-1.5998	-1.4589	-0.6455
0.725	*****	-1.6075	*****	-0.6287	0.725	*****	-1.6075	*****	-0.6287
0.750	-1.3404	-1.4631	*****	-0.6082	0.750	-1.3404	-1.4631	*****	-0.6082
0.775	*****	-1.4025	-1.2177	-0.6178	0.775	*****	-1.4025	-1.2177	-0.6178
0.800	-1.3736	-1.3323	-1.1706	-0.6363	0.800	-1.3736	-1.3323	-1.1706	-0.6363
0.825	*****	-1.2515	-1.1226	-0.6257	0.825	*****	-1.2515	-1.1226	-0.6257
0.850	-1.3631	-1.1916	-1.0748	-0.6354	0.850	-1.3631	-1.1916	-1.0748	-0.6354
0.875	*****	-1.1528	-1.0426	-0.6178	0.875	*****	-1.1528	-1.0426	-0.6178
0.900	-1.3067	-1.1232	-0.9664	-0.6259	0.900	-1.3067	-1.1232	-0.9664	-0.6259
0.925	*****	-1.0766	-0.8997	-0.6426	0.925	*****	-1.0766	-0.8997	-0.6426
0.950	-1.2545	-1.0305	-0.8684	-0.6388	0.950	-1.2545	-1.0305	-0.8684	-0.6388
0.975	*****	-1.0007	-0.8420	-0.5953	0.975	*****	-1.0007	-0.8420	-0.5953
1.000	-1.4097	-1.1085	-0.8206	-0.7408	1.000	-1.4097	-1.1085	-0.8206	-0.7408
-0.200	$C_{p,l}$	$C_{p,l}$	$C_{p,l}$	$C_{p,l}$	-0.200	0.4019	0.3626	0.3516	*****
-0.400	0.4000	0.3721	0.3277	0.1374	-0.400	0.4000	0.3721	0.3277	0.1374
-0.600	0.4161	0.3756	0.3245	0.1711	-0.600	0.4161	0.3756	0.3245	0.1711
-0.700	0.4247	0.3759	0.3305	0.1904	-0.700	0.4247	0.3759	0.3305	0.1904
-0.800	0.4209	*****	0.3275	0.2127	-0.800	0.4209	*****	0.3275	0.2127
-0.850	*****	0.3824	0.3294	0.2192	-0.850	*****	0.3824	0.3294	0.2192
-0.900	*****	0.3565	0.3178	0.2281	-0.900	*****	0.3565	0.3178	0.2281
-0.950	0.2348	0.2584	0.2447	0.1943	-0.950	0.2348	0.2584	0.2447	0.1943
-0.975	*****	0.0852	0.1087	0.0915	-0.975	*****	0.0852	0.1087	0.0915
-1.000	-1.3329	-1.0681	-0.8954	-0.9514	-1.000	-1.3329	-1.0681	-0.8954	-0.9514

Medium Radius L.E.
 Run No. = 15 , Point No. = 329
 $C_N = 0.763$, $C_m = -0.1013$
 $\alpha = 16.7^\circ$, $M_\infty = 0.850$
 $R_{mac} = 95.8 \times 10^6$



x/c_R	starb'd C_p	port C_p
0.10	-1.1106	*****
0.20	-1.4097	-1.3329
0.30	-1.2394	*****
0.40	-1.1085	-1.0681
0.50	-1.0715	*****
0.60	-0.8206	-0.8954
0.70	-0.7579	*****
0.80	-0.7408	-0.9514
0.90	*****	*****
0.95	-0.5055	-0.3989

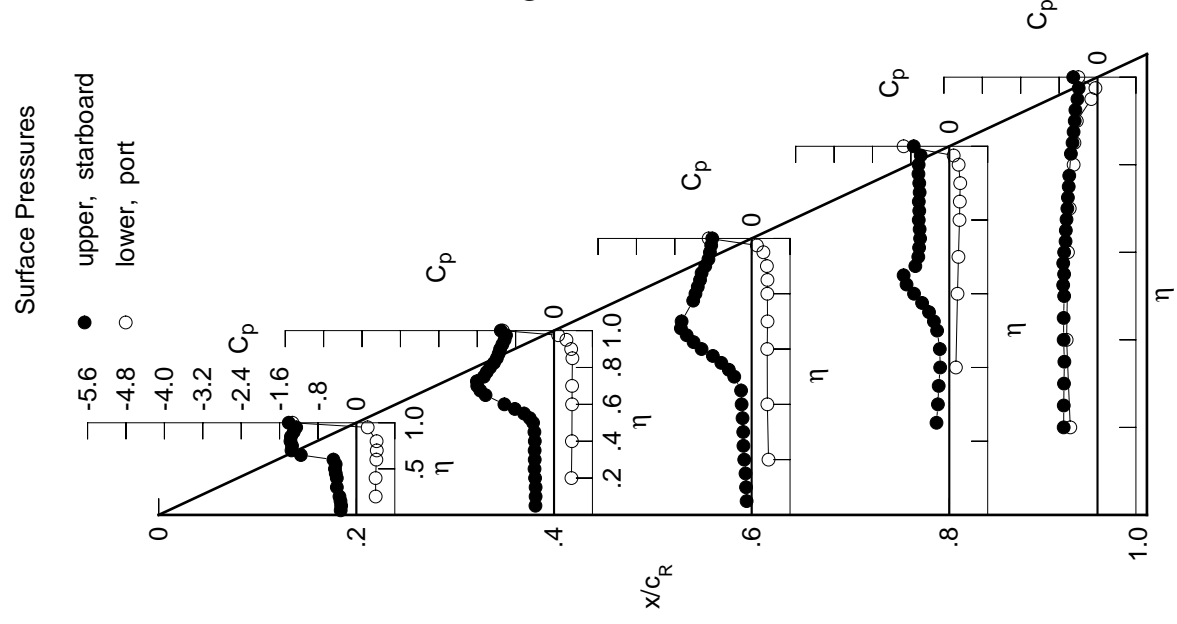
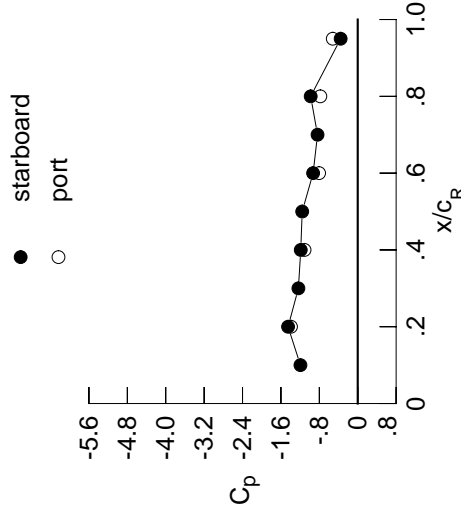

Table E9. Concluded.

η	$x/c_R = .2$		$x/c_R = .4$		$x/c_R = .6$		$x/c_R = .8$		$x/c_R = .95$	
	$C_{p,u}$	$C_{p,u}$	$C_{p,u}$	$C_{p,u}$	$C_{p,u}$	$C_{p,u}$	$C_{p,u}$	$C_{p,u}$	$C_{p,u}$	$C_{p,u}$
0.050	-0.3962	-0.4628	-0.0834	*****	*****	*****	*****	*****	*****	*****
0.100	-0.3874	-0.4628	-0.1003	*****	*****	*****	*****	*****	*****	*****
0.150	-0.4011	-0.4592	-0.1150	*****	*****	*****	*****	*****	*****	*****
0.200	-0.4572	-0.4783	-0.1472	*****	*****	*****	*****	*****	*****	*****
0.250	*****	-0.4802	-0.1651	-0.4344	-0.6291	*****	*****	*****	*****	*****
0.300	-0.4407	-0.4800	-0.1818	-0.4345	-0.6558	*****	*****	*****	*****	*****
0.350	*****	-0.4873	-0.2139	-0.4500	-0.6804	*****	*****	*****	*****	*****
0.400	-0.4654	-0.4972	-0.2673	-0.4765	-0.7253	*****	*****	*****	*****	*****
0.450	-0.4741	-0.5530	-0.3435	-0.5508	-0.7901	*****	*****	*****	*****	*****
0.500	-0.4805	-0.6887	-0.5920	-0.6877	-0.8998	*****	*****	*****	*****	*****
0.525	*****	-0.8354	-0.7549	-0.7875	-0.9775	*****	*****	*****	*****	*****
0.550	-0.6466	-1.0338	-0.9296	-0.9016	-1.0532	*****	*****	*****	*****	*****
0.575	*****	-1.2211	-1.0981	-1.0334	-0.9965	*****	*****	*****	*****	*****
0.600	-1.2224	-1.3768	-1.2769	-1.1600	-0.7325	*****	*****	*****	*****	*****
0.625	*****	*****	-1.3868	-1.2715	-0.6101	*****	*****	*****	*****	*****
0.650	-1.5341	-1.6007	-1.3608	-1.0457	-0.5327	*****	*****	*****	*****	*****
0.675	*****	-1.6694	-1.1653	-0.9394	-0.5008	*****	*****	*****	*****	*****
0.700	-1.5037	-1.6987	-1.1348	-0.9249	-0.4939	*****	*****	*****	*****	*****
0.725	*****	-1.5488	*****	-0.9305	-0.4933	*****	*****	*****	*****	*****
0.750	-1.5658	-1.5083	*****	-0.9326	-0.4853	*****	*****	*****	*****	*****
0.775	*****	-1.4280	-1.1691	-0.9513	-0.4753	*****	*****	*****	*****	*****
0.800	-1.4762	-1.3284	-1.2471	-0.9745	*****	*****	*****	*****	*****	*****
0.825	*****	-1.2383	-1.2942	-0.9466	-0.4630	*****	*****	*****	*****	*****
0.850	-1.4098	-1.2127	-1.1919	-0.9417	-0.4427	*****	*****	*****	*****	*****
0.875	*****	-1.2119	-1.0493	-0.9024	-0.4284	*****	*****	*****	*****	*****
0.900	-1.2932	-1.1707	-0.9842	-0.8958	-0.4072	*****	*****	*****	*****	*****
0.925	*****	-1.1242	-0.9937	-0.9091	-0.3829	*****	*****	*****	*****	*****
0.950	-1.2132	-1.1072	-0.9953	-0.9211	-0.3508	*****	*****	*****	*****	*****
0.975	*****	-1.0878	-0.9704	-0.8719	-0.3249	*****	*****	*****	*****	*****
1.000	-1.4512	-1.1869	-0.9296	-0.9804	-0.3557	*****	*****	*****	*****	*****
-0.200	$C_{p,l}$	$C_{p,l}$	$C_{p,l}$	$C_{p,l}$	$C_{p,l}$	$C_{p,l}$	$C_{p,l}$	$C_{p,l}$	$C_{p,l}$	$C_{p,l}$
-0.400	0.4602	0.4107	0.3876	*****	*****	*****	*****	*****	*****	*****
-0.600	0.4587	0.4191	0.3653	0.1668	-0.6355	*****	*****	*****	*****	*****
-0.700	0.4717	0.4216	0.3631	0.1996	-0.6101	*****	*****	*****	*****	*****
-0.800	0.4744	0.4204	0.3687	0.2187	-0.5741	*****	*****	*****	*****	*****
-0.850	0.4585	*****	0.3638	0.2399	-0.4955	*****	*****	*****	*****	*****
-0.900	*****	0.4125	0.3619	0.2443	-0.4825	*****	*****	*****	*****	*****
-0.950	0.2223	0.2487	0.2479	0.2067	-0.1552	*****	*****	*****	*****	*****
-0.975	*****	0.0488	0.0915	0.0989	-0.0917	*****	*****	*****	*****	*****
-1.000	-1.3902	-1.1084	-0.8051	-0.7789	-0.5202	*****	*****	*****	*****	*****

Medium Radius L.E.
 Run No. = 15 , Point No. = 330
 $C_N = 0.870$, $C_m = -0.1248$
 $\alpha = 18.7^\circ$, $M_\infty = 0.851$
 $R_{mac} = 95.5 \times 10^6$

Leading Edge Pressures



x/c_R	starb'd C_p	port C_p
0.10	-1.1940	*****
0.20	-1.4512	-1.3902
0.30	-1.2360	*****
0.40	-1.1869	-1.1084
0.50	-1.1570	*****
0.60	-0.9296	-0.8051
0.70	-0.8375	*****
0.80	-0.9804	-0.7789
0.90	*****	*****
0.95	-0.3557	-0.5202

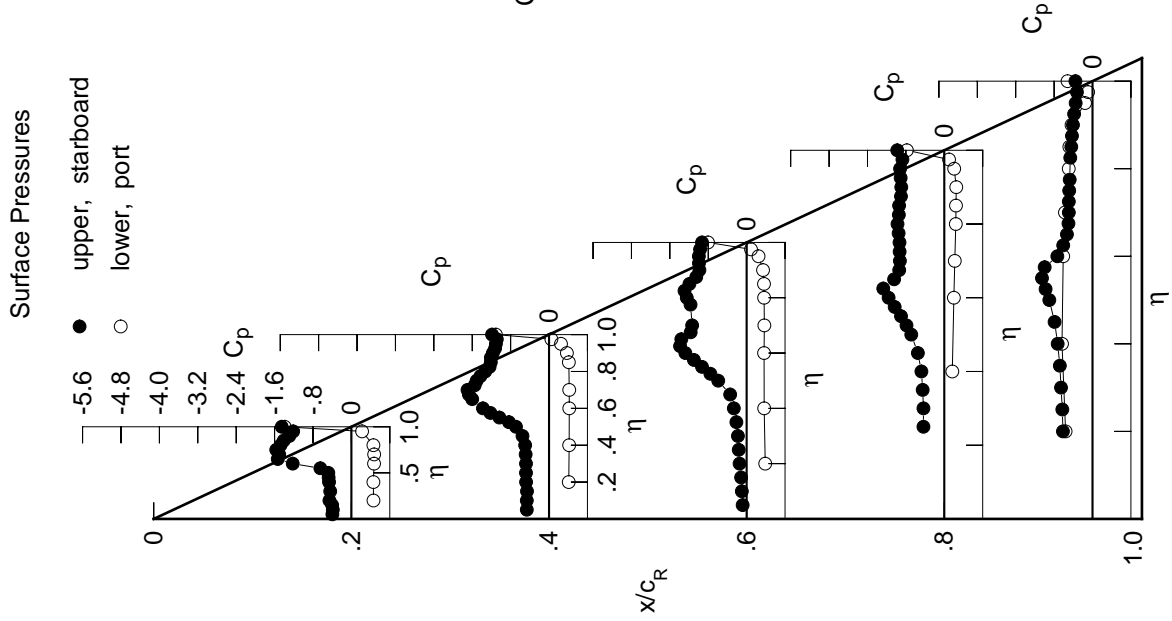

Table E10. Tabulations and Plots of Surface Pressure Coefficients.

η	x/c_R .2	x/c_R .4	x/c_R .6	x/c_R .8	x/c_R .95
	$C_{p,u}$	$C_{p,u}$	$C_{p,u}$	$C_{p,u}$	$C_{p,u}$
0.050	0.0035	0.0161	0.1398	*****	*****
0.100	0.0057	0.0161	0.1311	*****	*****
0.150	0.0017	0.0159	0.1178	*****	*****
0.200	0.0018	0.0214	0.1060	*****	-0.3255
0.250	*****	0.0147	0.0922	-0.1206	-0.4745
0.300	0.0069	0.0153	0.0834	-0.1035	-0.6746
0.350	*****	0.0135	0.0732	-0.0945	-0.7336
0.400	-0.0206	0.0135	0.0664	-0.0812	-0.7468
0.450	-0.0260	0.0095	0.0764	-0.0753	-0.7267
0.500	-0.0318	0.0114	0.0486	-0.0695	-0.6875
0.525	*****	0.0067	0.0466	-0.0676	-0.6858
0.550	-0.0304	0.0005	0.0440	-0.0650	-0.6724
0.575	*****	0.0001	0.0511	-0.0637	-0.6778
0.600	-0.0379	-0.0029	0.0346	-0.0637	-0.6773
0.625	*****	*****	0.0365	-0.0591	-0.6826
0.650	-0.0368	-0.0021	0.0311	-0.0565	-0.7040
0.675	*****	-0.0145	0.0240	-0.0594	-0.7062
0.700	-0.0306	-0.0214	0.0234	-0.0573	-0.7250
0.725	*****	-0.0281	*****	-0.0563	-0.7325
0.750	-0.0213	-0.0338	*****	-0.0551	-0.7287
0.775	*****	-0.0374	0.0034	-0.0610	-0.7188
0.800	-0.0004	-0.0404	-0.0087	-0.0656	*****
0.825	*****	-0.0383	-0.0198	-0.0615	-0.7010
0.850	0.0226	-0.0338	-0.0270	-0.0823	-0.6929
0.875	*****	-0.0229	-0.0319	-0.0899	-0.7433
0.900	0.0543	-0.0114	-0.0292	-0.0971	-0.7586
0.925	*****	0.0129	-0.0148	-0.0891	-1.0792
0.950	0.1043	0.0504	0.0159	-0.0593	-0.3828
0.975	*****	0.1063	0.0759	0.0024	-0.2046
1.000	0.2227	0.2154	0.1835	0.1535	0.0768
	$C_{p,l}$	$C_{p,l}$	$C_{p,l}$	$C_{p,l}$	$C_{p,l}$
-0.200	-0.0278	-0.0032	0.0801	*****	-0.6429
-0.400	-0.0524	-0.0041	0.0397	-0.1038	-0.6480
-0.600	-0.0767	-0.0294	0.0104	-0.0850	-0.6203
-0.700	-0.0802	-0.0660	-0.0116	-0.0843	-0.6263
-0.800	-0.0665	*****	-0.0603	-0.0978	-0.7196
-0.850	*****	-0.1003	-0.0922	-0.1295	-0.7341
-0.900	*****	-0.0886	-0.1104	-0.1669	-0.4905
-0.950	0.0312	-0.0413	-0.0811	-0.1587	-0.3924
-0.975	*****	0.0097	-0.0343	-0.1078	-0.2785
-1.000	0.1881	0.1805	0.1426	0.1338	0.0599

Medium Radius L.E.

Run No. = 16, Point No. = 333

$C_N = -0.031$, $C_m = 0.0045$

$\alpha = -0.8^\circ$, $M_\infty = 0.850$

$R_{mac} = 108.9 \times 10^6$

Surface Pressures

● upper, starboard
○ lower, port

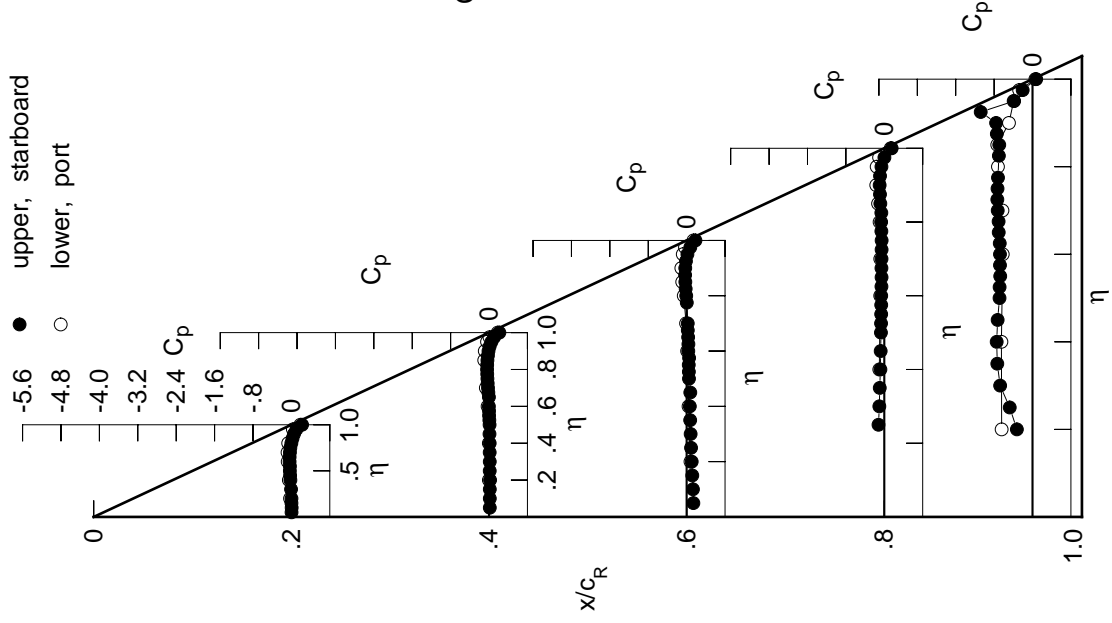

Leading Edge Pressures

● starboard
○ port

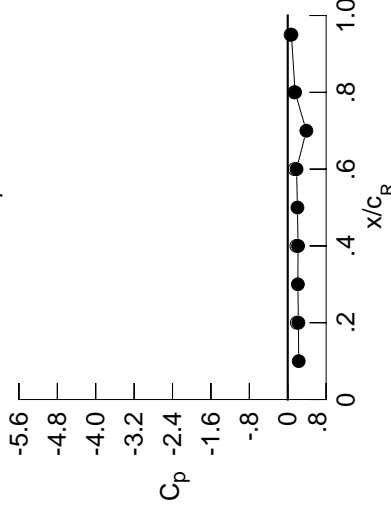

x/c_R	starb'd C_p	port C_p
0.10	0.2286	*****
0.20	0.2227	0.1881
0.30	0.2109	*****
0.40	0.2154	0.1805
0.50	0.2021	*****
0.60	0.1835	0.1426
0.70	0.3878	*****
0.80	0.1535	0.1338
0.90	*****	*****
0.95	0.0768	0.0599

Table E10. Continued.

η	$x/c_R = .2$		$x/c_R = .4$		$x/c_R = .6$		$x/c_R = .8$		$x/c_R = .95$	
	$C_{p,u}$	$C_{p,u}$	$C_{p,u}$	$C_{p,u}$	$C_{p,u}$	$C_{p,u}$	$C_{p,u}$	$C_{p,u}$	$C_{p,u}$	$C_{p,u}$
0.050	-0.0032	0.0096	0.1356	*****	*****	*****	*****	*****	*****	*****
0.100	-0.0017	0.0104	0.1270	*****	*****	*****	*****	*****	*****	*****
0.150	-0.0053	0.0096	0.1140	*****	*****	*****	*****	*****	*****	*****
0.200	-0.0058	0.0161	0.1019	*****	*****	*****	*****	*****	*****	*****
0.250	*****	0.0088	0.0881	-0.1251	-0.4637	*****	*****	*****	*****	*****
0.300	-0.0150	0.0099	0.0791	-0.1089	-0.6558	*****	*****	*****	*****	*****
0.350	*****	0.0066	0.0686	-0.0995	-0.7292	*****	*****	*****	*****	*****
0.400	-0.0297	0.0075	0.0617	-0.0866	-0.7434	*****	*****	*****	*****	*****
0.450	-0.0353	0.0034	0.0718	-0.0802	-0.7121	*****	*****	*****	*****	*****
0.500	-0.0418	0.0046	0.0435	-0.0744	-0.6462	*****	*****	*****	*****	*****
0.525	*****	-0.0007	0.0413	-0.0729	-0.6374	*****	*****	*****	*****	*****
0.550	-0.0410	-0.0074	0.0391	-0.0702	-0.6140	*****	*****	*****	*****	*****
0.575	-0.0492	-0.0070	0.0446	-0.0695	-0.6102	*****	*****	*****	*****	*****
0.600	-0.0492	-0.0114	0.0284	-0.0692	-0.6034	*****	*****	*****	*****	*****
0.625	*****	*****	0.0307	-0.0650	-0.6100	*****	*****	*****	*****	*****
0.650	-0.0489	-0.0119	0.0243	-0.0626	-0.6441	*****	*****	*****	*****	*****
0.675	*****	-0.0250	0.0171	-0.0664	-0.6597	*****	*****	*****	*****	*****
0.700	-0.0440	-0.0325	0.0156	-0.0641	-0.6975	*****	*****	*****	*****	*****
0.725	*****	-0.0404	*****	-0.0637	-0.7234	*****	*****	*****	*****	*****
0.750	-0.0352	-0.0463	*****	-0.0628	-0.7299	*****	*****	*****	*****	*****
0.775	*****	-0.0507	-0.0066	-0.0704	-0.7222	*****	*****	*****	*****	*****
0.800	-0.0153	-0.0556	-0.0199	-0.0749	*****	*****	*****	*****	*****	*****
0.825	*****	-0.0543	-0.0328	-0.0709	-0.6942	*****	*****	*****	*****	*****
0.850	0.0073	-0.0506	-0.0415	-0.0941	-0.6893	*****	*****	*****	*****	*****
0.875	*****	-0.0408	-0.0479	-0.1038	-0.7511	*****	*****	*****	*****	*****
0.900	0.0386	-0.0312	-0.0469	-0.1138	-0.7325	*****	*****	*****	*****	*****
0.925	*****	-0.0071	-0.0347	-0.1082	-0.9750	*****	*****	*****	*****	*****
0.950	0.0879	0.0292	-0.0058	-0.0813	-0.3945	*****	*****	*****	*****	*****
0.975	*****	0.0846	0.0525	-0.0223	-0.2222	*****	*****	*****	*****	*****
1.000	0.2266	0.2223	0.2024	0.1663	0.0871	*****	*****	*****	*****	*****
	$C_{p,l}$	$C_{p,l}$	$C_{p,l}$	$C_{p,l}$	$C_{p,l}$	$C_{p,l}$	$C_{p,l}$	$C_{p,l}$	$C_{p,l}$	$C_{p,l}$
-0.200	-0.0206	0.0031	0.0845	*****	-0.6504	*****	*****	*****	*****	*****
-0.400	-0.0445	0.0025	0.0447	-0.0999	-0.6356	*****	*****	*****	*****	*****
-0.600	-0.0660	-0.0204	0.0173	-0.0786	-0.6037	*****	*****	*****	*****	*****
-0.700	-0.0678	-0.0552	-0.0030	-0.0778	-0.6330	*****	*****	*****	*****	*****
-0.800	-0.0517	*****	-0.0487	-0.0883	-0.7194	*****	*****	*****	*****	*****
-0.850	*****	-0.0829	-0.0775	-0.1175	-0.7486	*****	*****	*****	*****	*****
-0.900	*****	-0.0683	-0.0909	-0.1494	-0.5069	*****	*****	*****	*****	*****
-0.950	0.0507	-0.0174	-0.0550	-0.1339	-0.3778	*****	*****	*****	*****	*****
-0.975	*****	0.0361	-0.0049	-0.0779	-0.2568	*****	*****	*****	*****	*****
-1.000	0.1949	0.1922	0.1601	0.1551	0.0737	*****	*****	*****	*****	*****

Medium Radius L.E.
 Run No. = 16 , Point No. = 334
 $C_N = -0.015$, $C_m = 0.0013$
 $\alpha = -0.4^\circ$, $M_\infty = 0.851$
 $R_{mac} = 108.9 \times 10^6$

Leading Edge Pressures

● starboard
 ○ port

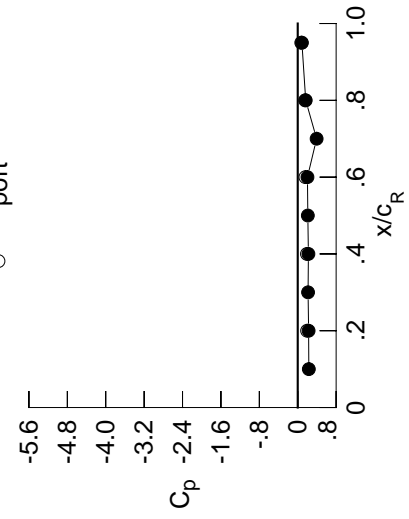

x/c_R	starb'd C_p	port C_p
0.10	0.2311	*****
0.20	0.2266	0.1949
0.30	0.2155	*****
0.40	0.2223	0.1922
0.50	0.2104	*****
0.60	0.2024	0.1601
0.70	0.3934	*****
0.80	0.1663	0.1551
0.90	*****	*****
0.95	0.0871	0.0737

Surface Pressures

● upper, starboard
 ○ lower, port

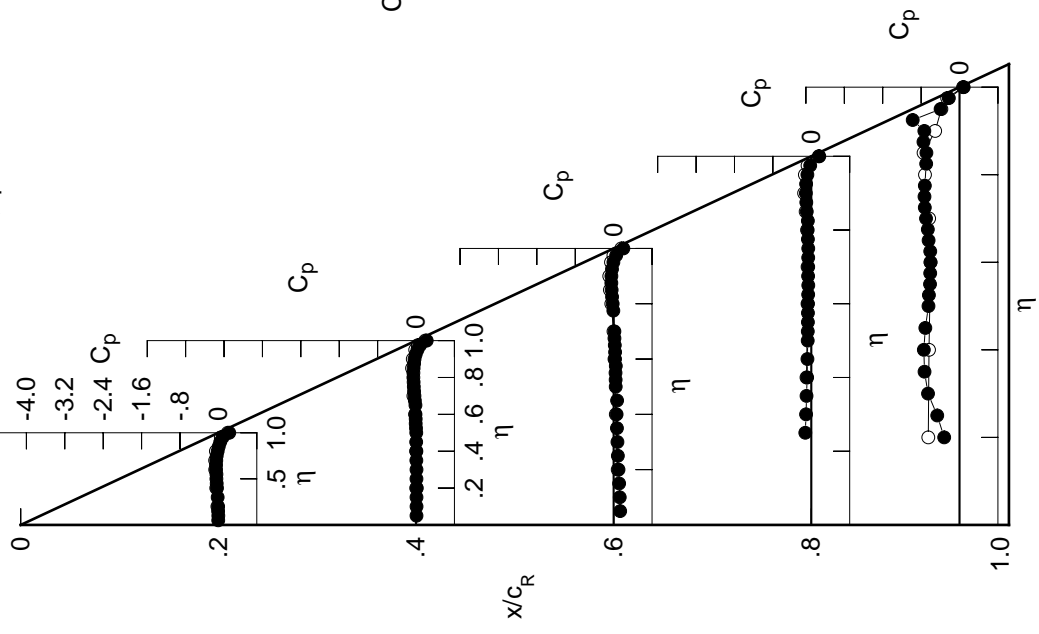

Table E10. Continued.

η	$x/c_R = .2$		$x/c_R = .4$		$x/c_R = .6$		$x/c_R = .8$		$x/c_R = .95$	
	$C_{p,u}$	$C_{p,u}$	$C_{p,u}$	$C_{p,u}$	$C_{p,u}$	$C_{p,u}$	$C_{p,u}$	$C_{p,u}$	$C_{p,u}$	$C_{p,u}$
0.050	-0.0245	-0.0087	0.1227	*****	*****	*****	*****	*****	*****	*****
0.100	-0.0224	-0.0082	0.1144	*****	*****	*****	*****	*****	*****	*****
0.150	-0.0261	-0.0086	0.1011	*****	*****	*****	*****	*****	*****	*****
0.200	-0.0266	-0.0038	0.0887	*****	*****	*****	*****	*****	*****	*****
0.250	*****	-0.0109	0.0745	-0.1368	-0.4337	*****	*****	*****	*****	*****
0.300	-0.0356	-0.0104	0.0651	-0.1208	-0.6063	*****	*****	*****	*****	*****
0.350	*****	-0.0134	0.0542	-0.1117	-0.7098	*****	*****	*****	*****	*****
0.400	-0.0526	-0.0138	0.0467	-0.0982	-0.7371	*****	*****	*****	*****	*****
0.450	-0.0612	-0.0179	0.0562	-0.0926	-0.7030	*****	*****	*****	*****	*****
0.500	-0.0689	-0.0182	0.0269	-0.0871	-0.6268	*****	*****	*****	*****	*****
0.525	*****	-0.0233	0.0244	-0.0868	-0.6184	*****	*****	*****	*****	*****
0.550	-0.0701	-0.0309	0.0207	-0.0842	-0.5935	*****	*****	*****	*****	*****
0.575	*****	-0.0327	0.0267	-0.0842	-0.5892	*****	*****	*****	*****	*****
0.600	-0.0801	-0.0370	0.0097	-0.0845	-0.5807	*****	*****	*****	*****	*****
0.625	*****	*****	0.0107	-0.0802	-0.5881	*****	*****	*****	*****	*****
0.650	-0.0823	-0.0383	0.0038	-0.0781	-0.6236	*****	*****	*****	*****	*****
0.675	*****	-0.0529	-0.0051	-0.0837	-0.6407	*****	*****	*****	*****	*****
0.700	-0.0797	-0.0626	-0.0072	-0.0821	-0.6832	*****	*****	*****	*****	*****
0.725	*****	-0.0724	*****	-0.0830	-0.7210	*****	*****	*****	*****	*****
0.750	-0.0735	-0.0813	*****	-0.0834	-0.7365	*****	*****	*****	*****	*****
0.775	*****	-0.0888	-0.0359	-0.0930	-0.7325	*****	*****	*****	*****	*****
0.800	-0.0561	-0.0964	-0.0529	-0.1010	*****	*****	*****	*****	*****	*****
0.825	*****	-0.0986	-0.0696	-0.0987	-0.6877	*****	*****	*****	*****	*****
0.850	-0.0361	-0.0982	-0.0834	-0.1275	-0.6880	*****	*****	*****	*****	*****
0.875	*****	-0.0921	-0.0955	-0.1433	-0.7502	*****	*****	*****	*****	*****
0.900	-0.0080	-0.0858	-0.1010	-0.1616	-0.5708	*****	*****	*****	*****	*****
0.925	*****	-0.0667	-0.0958	-0.1647	-0.7363	*****	*****	*****	*****	*****
0.950	0.0383	-0.0330	-0.0734	-0.1475	-0.4328	*****	*****	*****	*****	*****
0.975	*****	0.0169	-0.0215	-0.0980	-0.2795	*****	*****	*****	*****	*****
1.000	0.2209	0.2128	0.1979	0.1548	0.0811	*****	*****	*****	*****	*****
-0.200	$C_{p,l}$	$C_{p,l}$	$C_{p,l}$	$C_{p,l}$	$C_{p,l}$	$C_{p,l}$	$C_{p,l}$	$C_{p,l}$	$C_{p,l}$	$C_{p,l}$
-0.400	0.0006	0.0209	0.0983	*****	*****	*****	*****	*****	*****	*****
-0.600	-0.0209	0.0219	0.0602	-0.0869	-0.6592	*****	*****	*****	*****	*****
-0.700	-0.0358	0.0035	0.0365	-0.0635	-0.6465	*****	*****	*****	*****	*****
-0.800	-0.0326	-0.0249	0.0200	-0.0588	-0.6771	*****	*****	*****	*****	*****
-0.850	-0.0112	*****	-0.0171	-0.0634	-0.7075	*****	*****	*****	*****	*****
-0.900	*****	-0.0363	-0.0368	-0.0839	-0.7343	*****	*****	*****	*****	*****
-0.950	*****	-0.0149	-0.0388	-0.1024	-0.5843	*****	*****	*****	*****	*****
-0.975	0.0997	0.0428	0.0093	-0.0696	-0.3424	*****	*****	*****	*****	*****
-1.000	0.1944	0.1918	0.1602	0.1618	0.0786	*****	*****	*****	*****	*****

Medium Radius L.E.
 Run No. = 16 , Point No. = 335
 $C_N = 0.027$, $C_m = -0.0053$
 $\alpha = 0.7^\circ$, $M_\infty = 0.850$
 $R_{mac} = 108.9 \times 10^6$

Leading Edge Pressures

● starboard
 ○ port

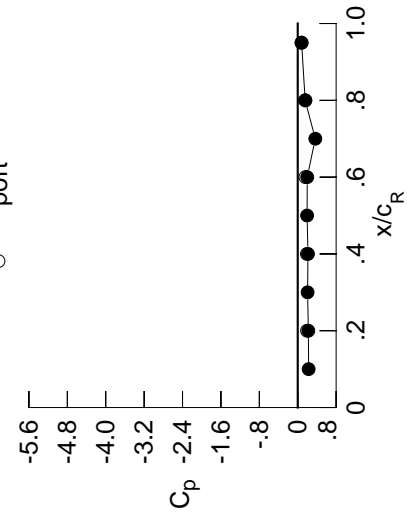

x/c_R	starb'd C_p	port C_p
0.10	0.2275	*****
0.20	0.2209	0.1944
0.30	0.2059	*****
0.40	0.2128	0.1918
0.50	0.1954	*****
0.60	0.1979	0.1602
0.70	0.3662	*****
0.80	0.1548	0.1618
0.90	*****	*****
0.95	0.0811	0.0786

Surface Pressures

● upper, starboard
 ○ lower, port

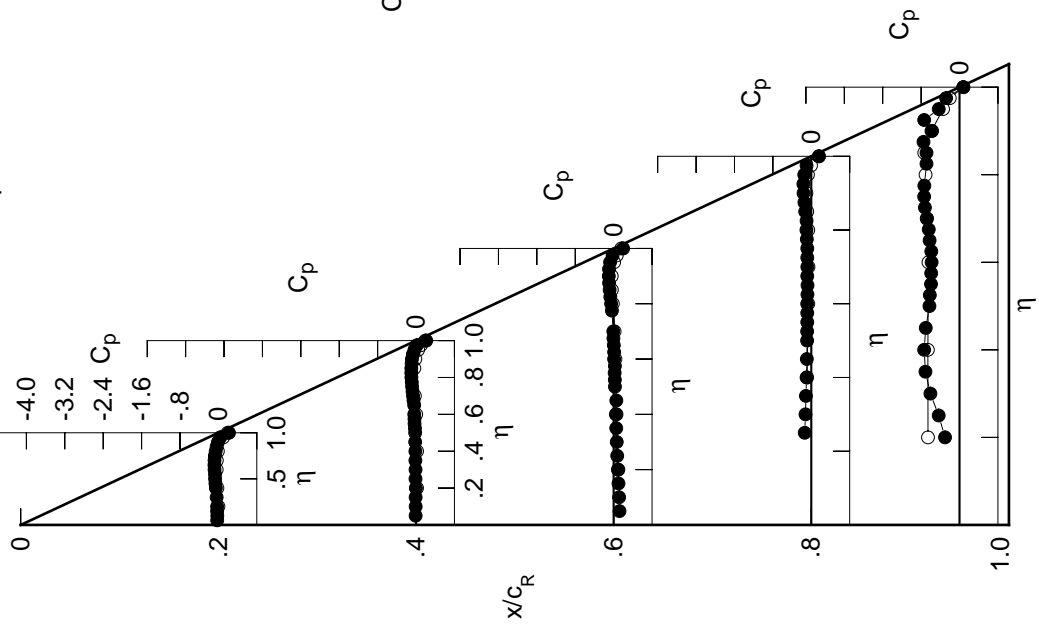

Table E10. Continued.

η	x/c_R .2	x/c_R .4	x/c_R .6	x/c_R .8	x/c_R .95
	$C_{p,u}$	$C_{p,u}$	$C_{p,u}$	$C_{p,u}$	$C_{p,u}$
0.050	-0.0449	-0.0260	0.1105	*****	*****
0.100	-0.0429	-0.0262	0.1017	*****	*****
0.150	-0.0464	-0.0267	0.0883	*****	*****
0.200	-0.0478	-0.0220	0.0756	*****	-0.2787
0.250	*****	-0.0293	0.0614	-0.1495	-0.4067
0.300	-0.0566	-0.0285	0.0516	-0.1335	-0.5998
0.350	*****	-0.0330	0.0395	-0.1244	-0.7336
0.400	-0.0762	-0.0331	0.0321	-0.1120	-0.7635
0.450	-0.0856	-0.0392	0.0403	-0.1063	-0.7459
0.500	-0.0954	-0.0402	0.0101	-0.1024	-0.6926
0.525	*****	-0.0462	0.0069	-0.1014	-0.6869
0.550	-0.0996	-0.0543	0.0028	-0.1003	-0.6769
0.575	*****	-0.0568	0.0078	-0.1002	-0.6909
0.600	-0.1113	-0.0624	-0.0101	-0.1012	-0.7056
0.625	*****	*****	-0.0095	-0.0979	-0.7254
0.650	-0.1170	-0.0664	-0.0171	-0.0965	-0.7512
0.675	*****	-0.0827	-0.0271	-0.1026	-0.7438
0.700	-0.1172	-0.0948	-0.0311	-0.1026	-0.7460
0.725	*****	-0.1074	*****	-0.1047	-0.7034
0.750	-0.1142	-0.1191	*****	-0.1075	-0.5534
0.775	*****	-0.1297	-0.0672	-0.1183	-0.3789
0.800	-0.1006	-0.1414	-0.0877	-0.1293	*****
0.825	*****	-0.1473	-0.1093	-0.1287	-0.3435
0.850	-0.0836	-0.1520	-0.1301	-0.1640	-0.3983
0.875	*****	-0.1511	-0.1485	-0.1877	-0.7318
0.900	-0.0611	-0.1494	-0.1626	-0.2157	-0.7057
0.925	*****	-0.1361	-0.1651	-0.2294	-1.0629
0.950	-0.0200	-0.1087	-0.1539	-0.2257	-0.4772
0.975	*****	-0.0704	-0.1149	-0.1916	-0.3498
1.000	0.1871	0.1515	0.1155	0.0632	0.0150
	$C_{p,l}$	$C_{p,l}$	$C_{p,l}$	$C_{p,l}$	$C_{p,l}$
-0.200	0.0226	0.0401	0.1122	*****	-0.6812
-0.400	0.0037	0.0428	0.0765	-0.0732	-0.7064
-0.600	-0.0051	0.0283	0.0557	-0.0479	-0.7089
-0.700	0.0022	0.0045	0.0434	-0.0401	-0.7198
-0.800	0.0286	*****	0.0143	-0.0374	-0.6909
-0.850	*****	0.0080	0.0027	-0.0521	-0.7109
-0.900	*****	0.0357	0.0096	-0.0584	-0.7237
-0.950	0.1423	0.0955	0.0653	-0.0125	-0.3111
-0.975	*****	0.1537	0.1233	0.0538	-0.1562
-1.000	0.1627	0.1409	0.0861	0.0875	0.0275

Medium Radius L.E.
 Run No. = 16, Point No. = 336
 $C_N = 0.069$, $C_m = -0.0118$
 $\alpha = 1.8^\circ$, $M_\infty = 0.850$
 $R_{mac} = 108.8 \times 10^6$

Leading Edge Pressures

● starboard
 ○ port

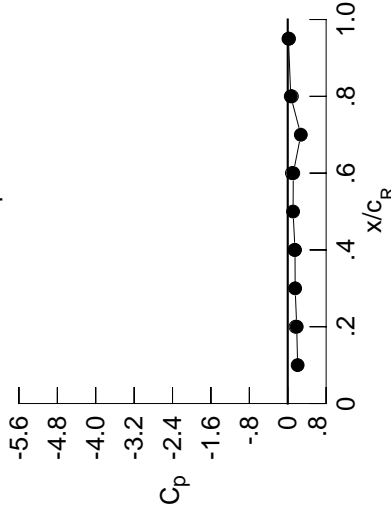

x/c_R	starb'd C_p	port C_p
0.10	0.2061	*****
0.20	0.1871	0.1627
0.30	0.1548	*****
0.40	0.1515	0.1409
0.50	0.1113	*****
0.60	0.1155	0.0861
0.70	0.2732	*****
0.80	0.0632	0.0875
0.90	*****	*****
0.95	0.0150	0.0275

Surface Pressures

● upper, starboard
 ○ lower, port

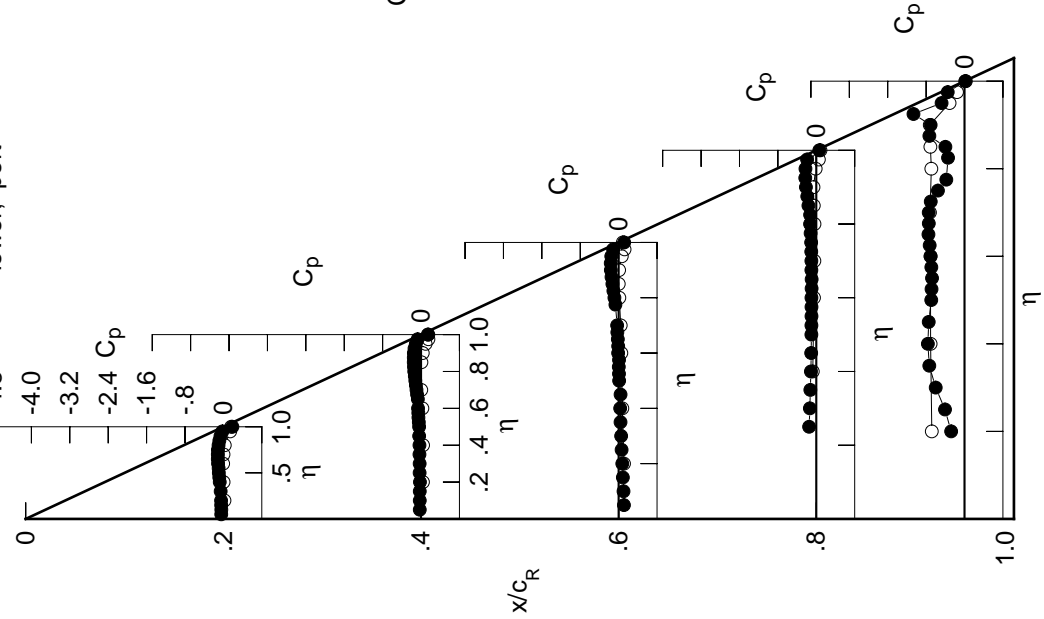

Table E10. Continued.

η	$x/c_R = .2$		$x/c_R = .4$		$x/c_R = .6$		$x/c_R = .8$		$x/c_R = .95$		
	$C_{p,u}$	$C_{p,l}$	$C_{p,u}$	$C_{p,l}$	$C_{p,u}$	$C_{p,l}$	$C_{p,u}$	$C_{p,l}$	$C_{p,u}$	$C_{p,l}$	
0.050	-0.0645	-0.0435	0.0983	*****	0.0983	*****	0.0983	*****	0.0983	*****	
0.100	-0.0631	-0.0432	0.0894	*****	0.0894	*****	0.0894	*****	0.0894	*****	
0.150	-0.0662	-0.0449	0.0753	*****	0.0753	*****	0.0753	*****	0.0753	*****	
0.200	-0.0676	-0.0397	0.0630	*****	0.0630	*****	0.0630	*****	0.0630	*****	
0.250	*****	-0.0471	0.0475	0.1619	-0.1619	-0.3826	0.1619	-0.3826	0.1619	-0.3826	
0.300	-0.0784	-0.0476	0.0376	-0.1462	-0.1462	-0.5556	0.1462	-0.5556	0.1462	-0.5556	
0.350	*****	-0.0518	0.0252	-0.1374	-0.1374	-0.7112	0.1374	-0.7112	0.1374	-0.7112	
0.400	-0.1007	-0.0529	0.0165	-0.1253	-0.1253	-0.7540	0.1253	-0.7540	0.1253	-0.7540	
0.450	-0.1112	-0.0598	0.0244	-0.1206	-0.1206	-0.7375	0.1206	-0.7375	0.1206	-0.7375	
0.500	-0.1230	-0.0611	-0.0071	-0.1166	-0.1166	-0.6814	0.1166	-0.6814	0.1166	-0.6814	
0.525	*****	-0.0683	-0.0108	-0.1166	-0.1166	-0.6772	0.1166	-0.6772	0.1166	-0.6772	
0.550	-0.1294	-0.0778	-0.0157	-0.1153	-0.1153	-0.6690	0.1153	-0.6690	0.1153	-0.6690	
0.575	*****	-0.0811	-0.0112	-0.1159	-0.1159	-0.6877	0.1159	-0.6877	0.1159	-0.6877	
0.600	-0.1436	-0.0875	-0.0295	-0.1184	-0.1184	-0.7085	0.1184	-0.7085	0.1184	-0.7085	
0.625	*****	*****	-0.0301	-0.1154	-0.1154	-0.7288	0.1154	-0.7288	0.1154	-0.7288	
0.650	-0.1522	-0.0948	-0.0385	-0.1150	-0.1150	-0.7501	0.1150	-0.7501	0.1150	-0.7501	
0.675	*****	-0.1125	-0.0501	-0.1222	-0.1222	-0.7265	0.1222	-0.7265	0.1222	-0.7265	
0.700	-0.1556	-0.1273	-0.0555	-0.1228	-0.1228	-0.6698	0.1228	-0.6698	0.1228	-0.6698	
0.725	*****	-0.1424	*****	-0.1270	-0.1270	-0.5435	0.1270	-0.5435	0.1270	-0.5435	
0.750	-0.1564	-0.1568	*****	-0.1315	-0.1315	-0.3998	0.1315	-0.3998	0.1315	-0.3998	
0.775	*****	-0.1720	-0.0987	-0.1445	-0.1445	-0.2741	0.1445	-0.2741	0.1445	-0.2741	
0.800	-0.1473	-0.1871	-0.1232	-0.1586	-0.1586	*****	0.1586	*****	0.1586	*****	
0.825	*****	-0.1978	-0.1506	-0.1599	-0.1599	-0.2849	0.1599	-0.2849	0.1599	-0.2849	
0.850	-0.1355	-0.2068	-0.1774	-0.2011	-0.2011	-0.3194	0.2011	-0.3194	0.2011	-0.3194	
0.875	*****	-0.2120	-0.2039	-0.2336	-0.2336	-0.5383	0.2336	-0.5383	0.2336	-0.5383	
0.900	-0.1185	-0.2164	-0.2272	-0.2712	-0.2712	-0.6483	0.2712	-0.6483	0.2712	-0.6483	
0.925	*****	-0.2106	-0.2405	-0.2982	-0.2982	-0.9113	0.2982	-0.9113	0.2982	-0.9113	
0.950	-0.0861	-0.1919	-0.2434	-0.3098	-0.3098	-0.5263	0.3098	-0.5263	0.3098	-0.5263	
0.975	*****	-0.1684	-0.2234	-0.2986	-0.2986	-0.4287	0.2986	-0.4287	0.2986	-0.4287	
1.000	0.1202	0.0371	-0.0113	-0.1017	-0.1017	-0.1072	0.1017	-0.1072	0.1017	-0.1072	
-0.200	$C_{p,l}$	0.0440	0.0582	0.1251	*****	-0.6772	$C_{p,l}$	0.0440	0.0582	0.1251	*****
-0.400	0.0271	0.0614	0.0912	-0.0600	-0.7364	0.0912	-0.0600	-0.7364	0.0912	-0.0600	
-0.600	0.0239	0.0515	0.0728	-0.0334	-0.7348	0.0728	-0.0334	-0.7348	0.0728	-0.0334	
-0.700	0.0348	0.0323	0.0650	-0.0228	-0.7225	0.0650	-0.0228	-0.7225	0.0650	-0.0228	
-0.800	0.0647	*****	0.0420	-0.0159	-0.6748	0.0420	-0.0159	-0.6748	0.0420	-0.0159	
-0.850	*****	0.0474	0.0374	-0.0227	-0.6892	0.0374	-0.0227	-0.6892	0.0374	-0.0227	
-0.900	*****	0.0784	0.0513	-0.0194	-0.7232	0.0513	-0.0194	-0.7232	0.0513	-0.0194	
-0.950	0.1755	0.1373	0.1096	0.0349	-0.2848	0.1096	0.0349	-0.2848	0.1096	0.0349	
-0.975	*****	0.1881	0.1631	0.0975	-0.1201	0.1631	0.0975	-0.1201	0.1631	0.0975	
-1.000	0.0979	0.0358	-0.0724	-0.0573	-0.0687	-0.0724	-0.0573	-0.0687	-0.0724	-0.0573	

Medium Radius L.E.
 Run No. = 16 , Point No. = 337
 $C_N = 0.111$, $C_m = -0.0182$
 $\alpha = 2.9^\circ$, $M_\infty = 0.850$
 $R_{mac} = 108.8 \times 10^6$

Leading Edge Pressures

● starboard
 ○ port

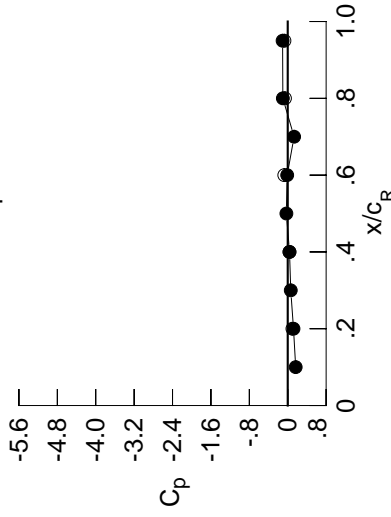

x/c_R	starb'd C_p	port C_p
0.10	0.1659	*****
0.20	0.1202	0.0979
0.30	0.0631	*****
0.40	0.0371	0.0358
0.50	-0.0282	*****
0.60	-0.0113	-0.0724
0.70	0.1326	*****
0.80	-0.1017	-0.0573
0.90	*****	*****
0.95	-0.1072	-0.0687

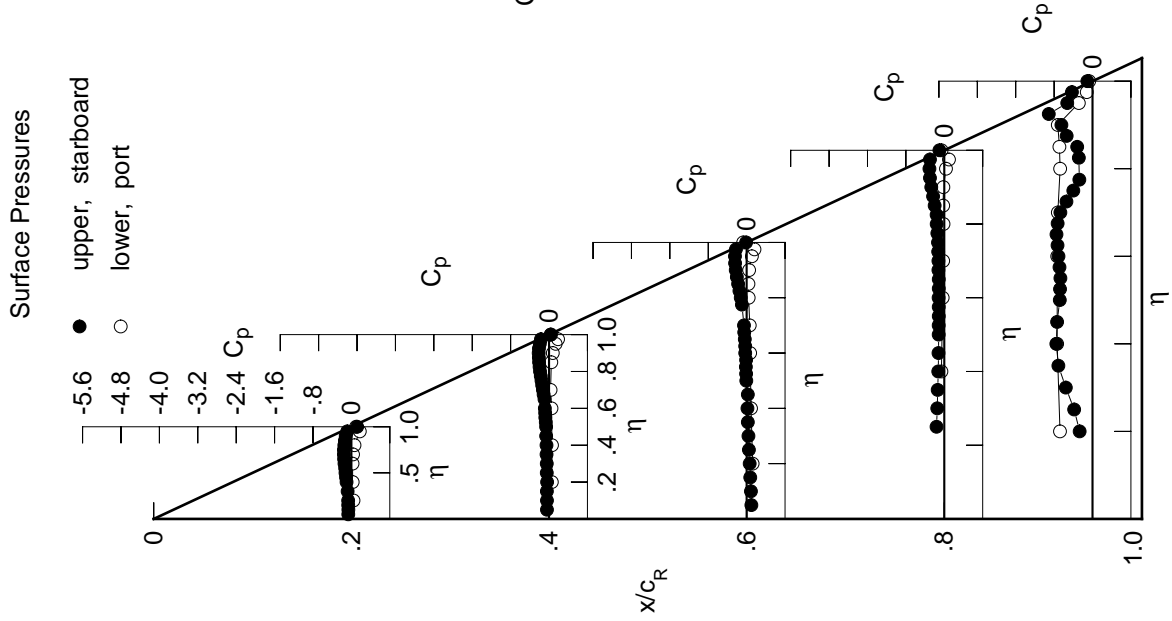

Table E10. Continued.

η	$x/c_R = .2$		$x/c_R = .4$		$x/c_R = .6$		$x/c_R = .8$		$x/c_R = .95$	
	$C_{p,u}$	$C_{p,u}$	$C_{p,u}$	$C_{p,u}$	$C_{p,u}$	$C_{p,u}$	$C_{p,u}$	$C_{p,u}$	$C_{p,u}$	$C_{p,u}$
0.050	-0.0830	-0.0607	0.0874	0.0874	0.0874	0.0874	0.0874	0.0874	0.0874	0.0874
0.100	-0.0816	-0.0611	0.0780	0.0780	0.0780	0.0780	0.0780	0.0780	0.0780	0.0780
0.150	-0.0854	-0.0622	0.0644	0.0644	0.0644	0.0644	0.0644	0.0644	0.0644	0.0644
0.200	-0.0875	-0.0572	0.0517	0.0517	0.0517	0.0517	0.0517	0.0517	0.0517	0.0517
0.250	*****	-0.0646	0.0361	0.0361	0.0361	0.0361	0.0361	0.0361	0.0361	0.0361
0.300	-0.0984	-0.0661	0.0255	0.0255	-0.1574	-0.5322	0.0255	0.0255	-0.1574	-0.5322
0.350	*****	-0.0708	0.0125	0.0125	-0.1482	-0.6948	0.0125	0.0125	-0.1482	-0.6948
0.400	-0.1227	-0.0725	0.0030	0.0030	-0.1371	-0.7513	0.0030	0.0030	-0.1371	-0.7513
0.450	-0.1350	-0.0806	0.0103	0.0103	-0.1329	-0.7392	0.0103	0.0103	-0.1329	-0.7392
0.500	-0.1488	-0.0828	-0.0221	-0.1297	-0.6890	0.0221	-0.1297	-0.6890	0.0221	-0.1297
0.525	*****	-0.0912	-0.0264	-0.1305	-0.6877	0.0264	-0.1305	-0.6877	0.0264	-0.1305
0.550	-0.1577	-0.1008	-0.0322	-0.1293	-0.6819	0.0322	-0.1293	-0.6819	0.0322	-0.1293
0.575	*****	-0.1056	-0.0286	-0.1310	-0.7023	0.0286	-0.1310	-0.7023	0.0286	-0.1310
0.600	-0.1745	-0.1132	-0.0478	-0.1338	-0.7211	0.0478	-0.1338	-0.7211	0.0478	-0.1338
0.625	*****	*****	-0.0491	-0.1321	-0.7308	0.0491	-0.1321	-0.7308	0.0491	-0.1321
0.650	-0.1869	-0.1214	-0.0588	-0.1324	-0.7282	0.0588	-0.1324	-0.7282	0.0588	-0.1324
0.675	*****	-0.1417	-0.0720	-0.1398	-0.6446	0.0720	-0.1398	-0.6446	0.0720	-0.1398
0.700	-0.1938	-0.1588	-0.0790	-0.1428	-0.5207	0.0790	-0.1428	-0.5207	0.0790	-0.1428
0.725	*****	-0.1770	*****	-0.1480	-0.4137	0.1480	-0.4137	0.1480	-0.4137	0.1480
0.750	-0.1992	-0.1945	*****	-0.1542	-0.3077	0.1542	-0.3077	0.1542	-0.3077	0.1542
0.775	*****	-0.2137	-0.1301	-0.1699	-0.2086	0.1301	-0.1699	-0.2086	0.1301	-0.1699
0.800	-0.1947	-0.2333	-0.1594	-0.1871	*****	0.1594	-0.1871	*****	0.1594	-0.1871
0.825	*****	-0.2501	-0.1927	-0.1919	-0.2403	0.1927	-0.1919	-0.2403	0.1927	-0.1919
0.850	-0.1887	-0.2641	-0.2255	-0.2391	-0.2578	0.2255	-0.2391	-0.2578	0.2255	-0.2391
0.875	*****	-0.2765	-0.2616	-0.2798	-0.4070	0.2616	-0.2798	-0.4070	0.2616	-0.2798
0.900	-0.1790	-0.2870	-0.2952	-0.3303	-0.6594	0.2952	-0.3303	-0.6594	0.2952	-0.3303
0.925	*****	-0.2919	-0.3212	-0.3707	-0.8953	0.3212	-0.3707	-0.8953	0.3212	-0.3707
0.950	-0.1578	-0.2843	-0.3406	-0.4017	-0.5811	0.3406	-0.4017	-0.5811	0.3406	-0.4017
0.975	*****	-0.2827	-0.3456	-0.4198	-0.5229	0.3456	-0.4198	-0.5229	0.3456	-0.4198
1.000	0.0249	-0.1298	-0.1795	-0.3327	-0.2858	0.1795	-0.3327	-0.2858	0.1795	-0.3327
	$C_{p,l}$	$C_{p,l}$	$C_{p,l}$	$C_{p,l}$	$C_{p,l}$	$C_{p,l}$	$C_{p,l}$	$C_{p,l}$	$C_{p,l}$	$C_{p,l}$
-0.200	0.0667	0.0777	0.1402	0.1402	0.1402	0.1402	0.1402	0.1402	0.1402	0.1402
-0.400	0.0517	0.0821	0.1076	0.1076	0.1076	0.1076	0.1076	0.1076	0.1076	0.1076
-0.600	0.0539	0.0752	0.0924	0.0924	0.0924	0.0924	0.0924	0.0924	0.0924	0.0924
-0.700	0.0676	0.0603	0.0864	0.0864	0.0864	0.0864	0.0864	0.0864	0.0864	0.0864
-0.800	0.0991	*****	0.0705	0.0067	-0.6577	0.0705	0.0067	-0.6577	0.0705	0.0067
-0.850	*****	0.0842	0.0706	0.0047	-0.6679	0.0706	0.0047	-0.6679	0.0706	0.0047
-0.900	*****	0.1173	0.0898	0.0158	-0.6863	0.0898	0.0158	-0.6863	0.0898	0.0158
-0.950	0.2028	0.1717	0.1471	0.0741	-0.2617	0.1471	0.0741	-0.2617	0.1471	0.0741
-0.975	*****	0.2108	0.1905	0.1293	-0.0927	0.1905	0.1293	-0.0927	0.1905	0.1293
-1.000	0.0056	-0.1092	-0.2979	-0.2719	-0.2147	0.2979	-0.2719	-0.2147	0.2979	-0.2719

Medium Radius L.E.
 Run No. = 16, Point No. = 338
 $C_N = 0.154$, $C_m = -0.0254$
 $\alpha = 3.9^\circ$, $M_\infty = 0.850$
 $R_{mac} = 108.9 \times 10^6$

Leading Edge Pressures

● starboard
 ○ port

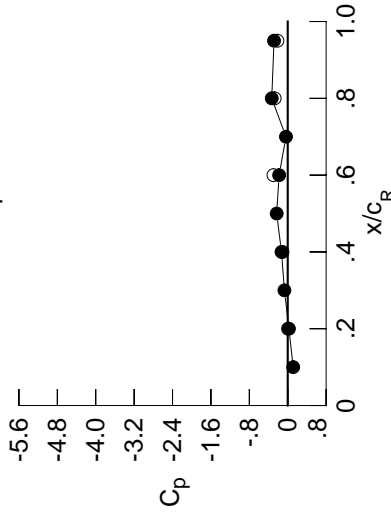

x/c_R	starb'd C_p	port C_p
0.10	0.1136	*****
0.20	0.0249	0.0056
0.30	-0.0686	*****
0.40	-0.1298	-0.1092
0.50	-0.2304	*****
0.60	-0.1795	-0.2979
0.70	-0.0370	*****
0.80	-0.3327	-0.2719
0.90	*****	*****
0.95	-0.2858	-0.2147

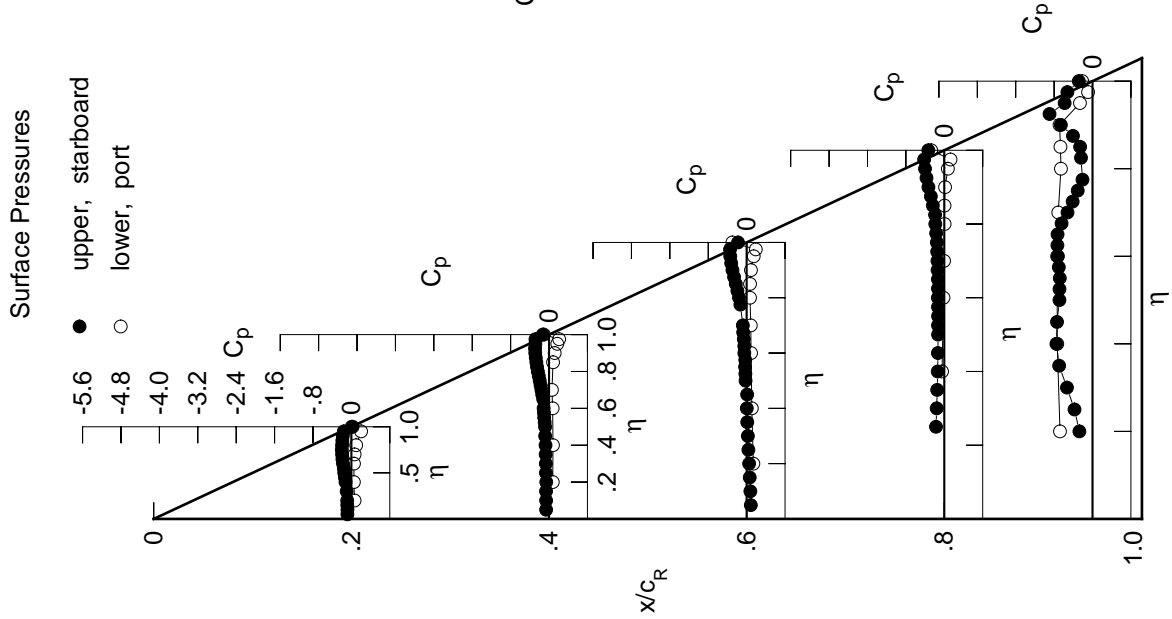

Table E10. Continued.

η	$x/c_R = .2$		$x/c_R = .4$		$x/c_R = .6$		$x/c_R = .8$		$x/c_R = .95$	
	$C_{p,u}$	$C_{p,u}$	$C_{p,u}$	$C_{p,u}$	$C_{p,u}$	$C_{p,u}$	$C_{p,u}$	$C_{p,u}$	$C_{p,u}$	$C_{p,u}$
0.050	-0.1012	-0.0772	0.0761	*****	*****	*****	*****	*****	*****	
0.100	-0.1001	-0.0768	0.0671	*****	*****	*****	*****	*****	*****	
0.150	-0.1042	-0.0789	0.0530	*****	*****	*****	*****	*****	*****	
0.200	-0.1059	-0.0740	0.0402	*****	*****	*****	*****	*****	-0.2848	
0.250	*****	-0.0823	0.0243	0.1841	-0.3656	*****	*****	*****	*****	
0.300	-0.1178	-0.0837	0.0132	-0.1680	-0.4972	*****	*****	*****	*****	
0.350	*****	-0.0896	-0.0006	-0.1604	-0.6563	*****	*****	*****	*****	
0.400	-0.1452	-0.0911	-0.0112	-0.1488	-0.7368	*****	*****	*****	*****	
0.450	-0.1595	-0.1007	-0.0048	-0.1457	-0.7354	*****	*****	*****	*****	
0.500	-0.1750	-0.1043	-0.0380	-0.1427	-0.6984	*****	*****	*****	*****	
0.525	*****	-0.1130	-0.0428	-0.1437	-0.6957	*****	*****	*****	*****	
0.550	-0.1864	-0.1247	-0.0492	-0.1436	-0.6891	*****	*****	*****	*****	
0.575	*****	-0.1301	-0.0464	-0.1455	-0.7068	*****	*****	*****	*****	
0.600	-0.2064	-0.1389	-0.0674	-0.1496	-0.7186	*****	*****	*****	*****	
0.625	*****	*****	-0.0693	-0.1481	-0.7162	*****	*****	*****	*****	
0.650	-0.2224	-0.1497	-0.0795	-0.1495	-0.6906	*****	*****	*****	*****	
0.675	*****	-0.1715	-0.0937	-0.1589	-0.5824	*****	*****	*****	*****	
0.700	-0.2337	-0.1912	-0.1030	-0.1627	-0.4722	*****	*****	*****	*****	
0.725	*****	-0.2124	*****	-0.1700	-0.3865	*****	*****	*****	*****	
0.750	-0.2435	-0.2335	*****	-0.1780	-0.2912	*****	*****	*****	*****	
0.775	*****	-0.2570	-0.1617	-0.1963	-0.2049	*****	*****	*****	*****	
0.800	-0.2447	-0.2820	-0.1951	-0.2166	*****	*****	*****	*****	*****	
0.825	*****	-0.3037	-0.2343	-0.2230	-0.2379	*****	*****	*****	*****	
0.850	-0.2447	-0.3242	-0.2754	-0.2768	-0.2539	*****	*****	*****	*****	
0.875	*****	-0.3437	-0.3210	-0.3273	-0.3770	*****	*****	*****	*****	
0.900	-0.2440	-0.3636	-0.3684	-0.3905	-0.6519	*****	*****	*****	*****	
0.925	*****	-0.3793	-0.4063	-0.4485	-0.8158	*****	*****	*****	*****	
0.950	-0.2375	-0.3875	-0.4488	-0.5004	-0.6418	*****	*****	*****	*****	
0.975	*****	-0.4126	-0.4962	-0.5562	-0.6260	*****	*****	*****	*****	
1.000	-0.1008	-0.3379	-0.3925	-0.6467	-0.5355	*****	*****	*****	*****	
	$C_{p,l}$	$C_{p,l}$	$C_{p,l}$	$C_{p,l}$	$C_{p,l}$	$C_{p,l}$	$C_{p,l}$	$C_{p,l}$	$C_{p,l}$	
-0.200	0.0890	0.0977	0.1553	*****	-0.6695	*****	*****	*****	*****	
-0.400	0.0767	0.1024	0.1238	-0.0321	-0.7350	*****	*****	*****	*****	
-0.600	0.0828	0.0990	0.1114	-0.0009	-0.7257	*****	*****	*****	*****	
-0.700	0.0988	0.0877	0.1076	0.0139	-0.7004	*****	*****	*****	*****	
-0.800	0.1311	*****	0.0968	0.0289	-0.6405	*****	*****	*****	*****	
-0.850	*****	0.1192	0.1009	0.0306	-0.6470	*****	*****	*****	*****	
-0.900	*****	0.1517	0.1225	0.0473	-0.6528	*****	*****	*****	*****	
-0.950	0.2234	0.1984	0.1755	0.1054	-0.2420	*****	*****	*****	*****	
-0.975	*****	0.2209	0.2050	0.1485	-0.0739	*****	*****	*****	*****	
-1.000	-0.1152	-0.2899	-0.5929	-0.5775	-0.4202	*****	*****	*****	*****	

Medium Radius L.E.
 Run No. = 16 , Point No. = 339
 $C_N = 0.198$, $C_m = -0.0321$
 $\alpha = 5.0^\circ$, $M_\infty = 0.851$
 $R_{mac} = 109.0 \times 10^6$

Leading Edge Pressures

● starboard
 ○ port

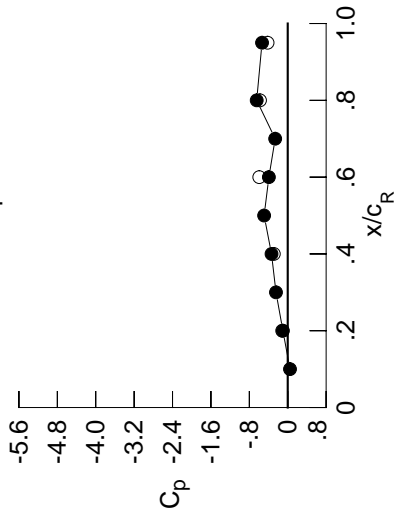

x/c_R	starb'd C_p	port C_p
0.10	0.0476	*****
0.20	-0.1008	-0.1152
0.30	-0.2445	*****
0.40	-0.3379	-0.2899
0.50	-0.4920	*****
0.60	-0.3925	-0.5929
0.70	-0.2614	*****
0.80	-0.6467	-0.5775
0.90	*****	*****
0.95	-0.5355	-0.4202

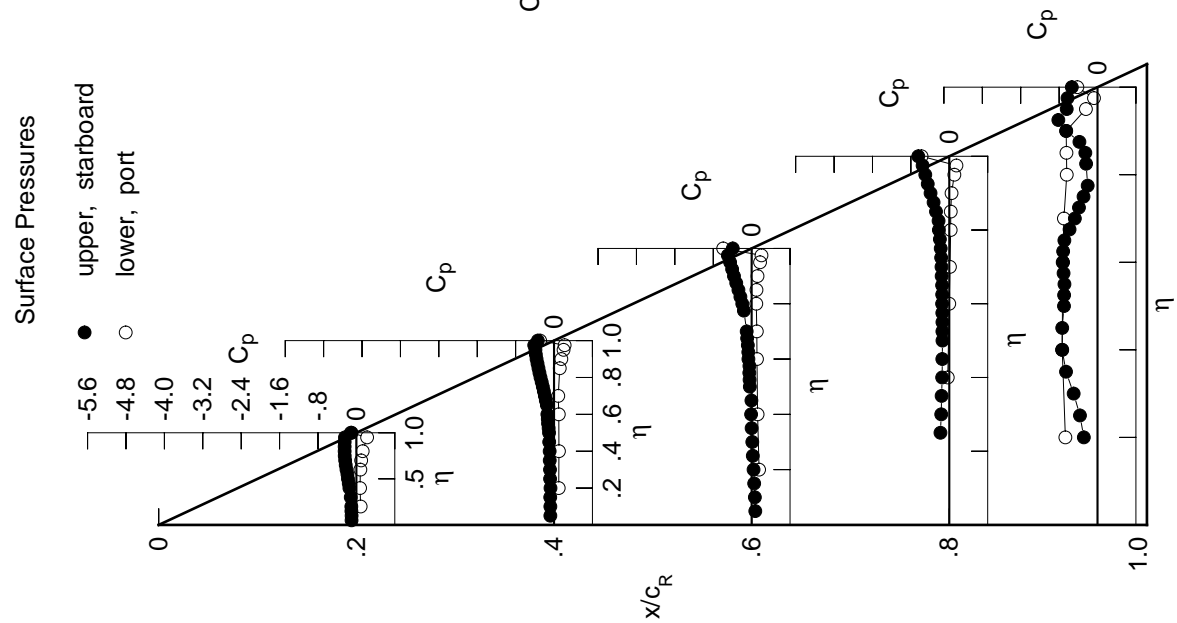
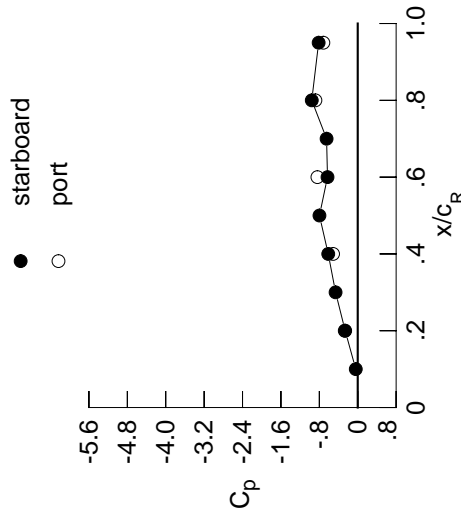

Table E10. Continued.

η	$x/c_R = .2$		$x/c_R = .4$		$x/c_R = .6$		$x/c_R = .8$		$x/c_R = .95$	
	$C_{p,u}$	$C_{p,u}$	$C_{p,u}$	$C_{p,u}$	$C_{p,u}$	$C_{p,u}$	$C_{p,u}$	$C_{p,u}$	$C_{p,u}$	$C_{p,u}$
0.050	-0.1212	-0.0947	0.0636	*****	*****	*****	*****	*****	*****	
0.100	-0.1212	-0.0955	0.0540	*****	*****	*****	*****	*****	*****	
0.150	-0.1250	-0.0974	0.0404	*****	*****	*****	*****	*****	*****	
0.200	-0.1279	-0.0930	0.0265	*****	*****	*****	*****	*****	-0.3153	
0.250	*****	-0.1009	0.0097	0.1967	-0.3646	*****	*****	*****	*****	
0.300	-0.1404	-0.1032	-0.0005	-0.1813	-0.4584	*****	*****	*****	*****	
0.350	*****	-0.1104	-0.0160	-0.1727	-0.5710	*****	*****	*****	*****	
0.400	-0.1704	-0.1124	-0.0270	-0.1622	-0.6718	*****	*****	*****	*****	
0.450	-0.1859	-0.1236	-0.0220	-0.1595	-0.7003	*****	*****	*****	*****	
0.500	-0.2042	-0.1283	-0.0557	-0.1578	-0.7001	*****	*****	*****	*****	
0.525	*****	-0.1383	-0.0620	-0.1593	-0.7131	*****	*****	*****	*****	
0.550	-0.2187	-0.1509	-0.0688	-0.1592	-0.7117	*****	*****	*****	*****	
0.575	*****	-0.1571	-0.0668	-0.1626	-0.7264	*****	*****	*****	*****	
0.600	-0.2416	-0.1677	-0.0891	-0.1672	-0.7281	*****	*****	*****	*****	
0.625	*****	*****	-0.0920	-0.1668	-0.7035	*****	*****	*****	*****	
0.650	-0.2611	-0.1811	-0.1034	-0.1703	-0.6338	*****	*****	*****	*****	
0.675	*****	-0.2058	-0.1194	-0.1807	-0.5202	*****	*****	*****	*****	
0.700	-0.2780	-0.2269	-0.1310	-0.1870	-0.4396	*****	*****	*****	*****	
0.725	*****	-0.2526	*****	-0.1970	-0.3687	*****	*****	*****	*****	
0.750	-0.2929	-0.2776	*****	-0.2093	-0.2782	*****	*****	*****	*****	
0.775	*****	-0.3058	-0.2003	-0.2315	-0.1971	*****	*****	*****	*****	
0.800	-0.3012	-0.3367	-0.2368	-0.2540	*****	*****	*****	*****	*****	
0.825	*****	-0.3639	-0.2813	-0.2640	-0.2291	*****	*****	*****	*****	
0.850	-0.3088	-0.3914	-0.3316	-0.3187	-0.2523	*****	*****	*****	*****	
0.875	*****	-0.4207	-0.3893	-0.3760	-0.3402	*****	*****	*****	*****	
0.900	-0.3196	-0.4505	-0.4477	-0.4512	-0.6371	*****	*****	*****	*****	
0.925	*****	-0.4822	-0.5033	-0.5254	-0.7984	*****	*****	*****	*****	
0.950	-0.3301	-0.5079	-0.5640	-0.6100	-0.7079	*****	*****	*****	*****	
0.975	*****	-0.5720	-0.6354	-0.7125	-0.7494	*****	*****	*****	*****	
1.000	-0.2615	-0.6146	-0.6299	-0.9577	-0.8147	*****	*****	*****	*****	
$C_{p,l}$	$C_{p,l}$	$C_{p,l}$	$C_{p,l}$	$C_{p,l}$	$C_{p,l}$	$C_{p,l}$	$C_{p,l}$	$C_{p,l}$	$C_{p,l}$	
-0.200	0.1123	0.1164	0.1695	*****	-0.6557	*****	*****	*****	*****	
-0.400	0.1017	0.1230	0.1388	-0.0185	-0.7359	*****	*****	*****	*****	
-0.600	0.1111	0.1219	0.1286	0.0142	-0.7171	*****	*****	*****	*****	
-0.700	0.1295	0.1140	0.1282	0.0301	-0.6904	*****	*****	*****	*****	
-0.800	0.1619	*****	0.1214	0.0488	-0.6269	*****	*****	*****	*****	
-0.850	*****	0.1506	0.1290	0.0543	-0.6295	*****	*****	*****	*****	
-0.900	*****	0.1813	0.1517	0.0752	-0.6246	*****	*****	*****	*****	
-0.950	0.2373	0.2172	0.1965	0.1293	-0.2282	*****	*****	*****	*****	
-0.975	*****	0.2196	0.2074	0.1565	-0.0660	*****	*****	*****	*****	
-1.000	-0.2704	-0.5139	-0.8399	-0.8819	-0.7161	*****	*****	*****	*****	

Medium Radius L.E.
 Run No. = 16 , Point No. = 340
 $C_N = 0.243$, $C_m = -0.0394$
 $\alpha = 6.1^\circ$, $M_\infty = 0.850$
 $R_{mac} = 108.8 \times 10^6$

Leading Edge Pressures



x/c_R	starb'd C_p	port C_p
0.10	-0.0410	*****
0.20	-0.2615	-0.2704
0.30	-0.4613	*****
0.40	-0.6146	-0.5139
0.50	-0.7975	*****
0.60	-0.6299	-0.8399
0.70	-0.6490	*****
0.80	-0.9577	-0.8819
0.90	*****	*****
0.95	-0.8147	-0.7161

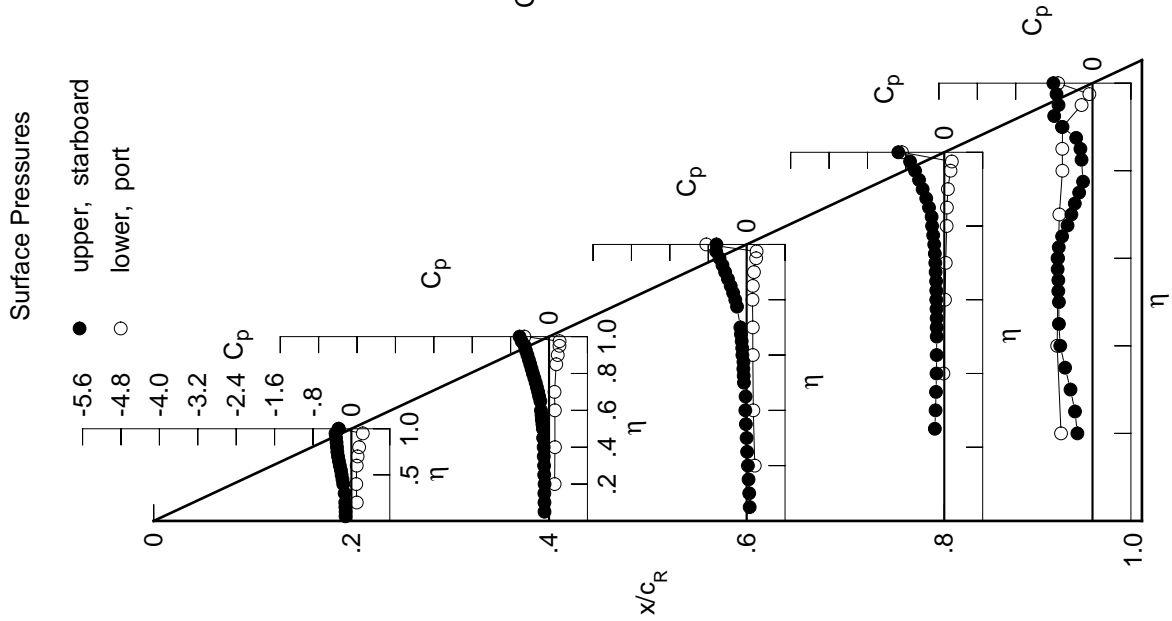
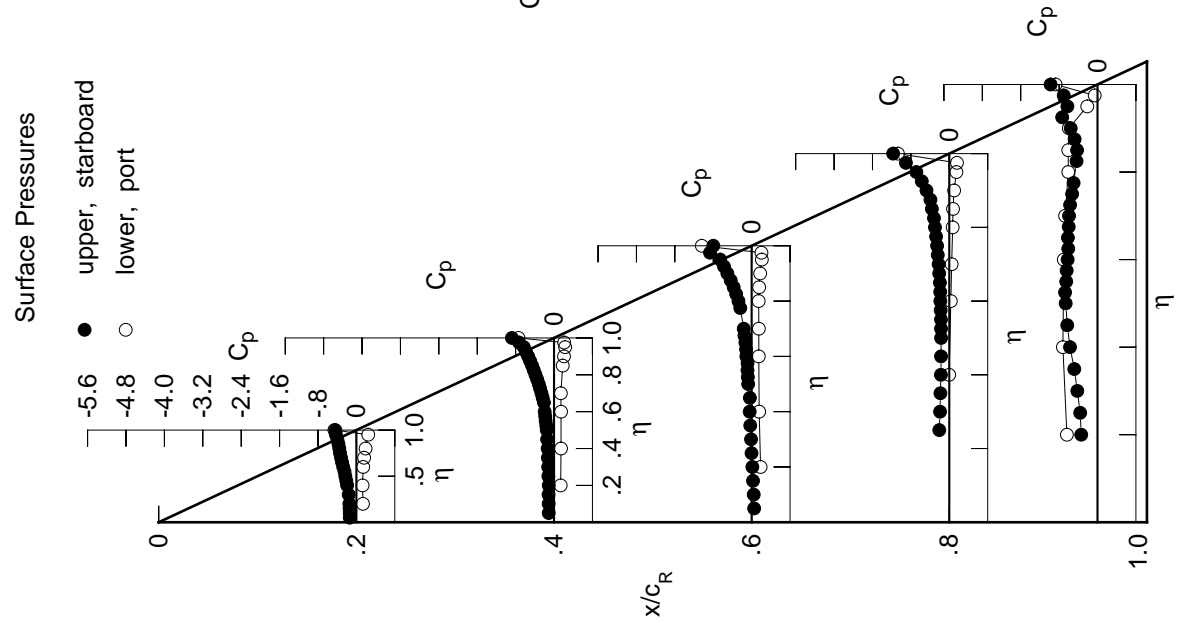

Table E10. Continued.

η	x/c_R .2	x/c_R .4	x/c_R .6	x/c_R .8	x/c_R .95
	$C_{p,u}$	$C_{p,u}$	$C_{p,u}$	$C_{p,u}$	$C_{p,u}$
0.050	-0.1380	-0.1112	0.0524	*****	*****
0.100	-0.1390	-0.1124	0.0430	*****	*****
0.150	-0.1431	-0.1148	0.0289	*****	*****
0.200	-0.1463	-0.1106	0.0150	*****	-0.3391
0.250	*****	-0.1187	-0.0022	-0.2077	-0.3610
0.300	-0.1601	-0.1224	-0.0131	-0.1922	-0.4205
0.350	*****	-0.1292	-0.0289	-0.1852	-0.4844
0.400	-0.1927	-0.1330	-0.0407	-0.1743	-0.5730
0.450	-0.2100	-0.1444	-0.0370	-0.1718	-0.6300
0.500	-0.2305	-0.1510	-0.0721	-0.1705	-0.6634
0.525	*****	-0.1619	-0.0790	-0.1723	-0.6756
0.550	-0.2475	-0.1756	-0.0866	-0.1730	-0.6522
0.575	*****	-0.1833	-0.0855	-0.1788	-0.6426
0.600	-0.2743	-0.1949	-0.1102	-0.1864	-0.6222
0.625	*****	*****	-0.1155	-0.1888	-0.6094
0.650	-0.2981	-0.2109	-0.1303	-0.1951	-0.6167
0.675	*****	-0.2371	-0.1493	-0.2095	-0.6003
0.700	-0.3199	-0.2618	-0.1651	-0.2222	-0.5928
0.725	*****	-0.2893	*****	-0.2397	-0.5713
0.750	-0.3408	-0.3186	*****	-0.2532	-0.5290
0.775	*****	-0.3560	-0.3866	-0.2745	-0.4982
0.800	-0.3560	-0.3866	-0.2745	-0.2987	*****
0.825	*****	-0.4226	-0.3215	-0.3189	-0.4369
0.850	-0.3733	-0.4573	-0.3742	-0.3620	-0.4252
0.875	*****	-0.4977	-0.4362	-0.3926	-0.4764
0.900	-0.3958	-0.5392	-0.5055	-0.4748	-0.5581
0.925	*****	-0.5852	-0.5763	-0.5729	-0.7357
0.950	-0.4263	-0.6289	-0.6555	-0.6863	-0.6273
0.975	*****	-0.7283	-0.8668	-0.9044	-0.7043
1.000	-0.4382	-0.8773	-0.7983	-1.1697	-0.9770
	$C_{p,l}$	$C_{p,l}$	$C_{p,l}$	$C_{p,l}$	$C_{p,l}$
-0.200	0.1371	0.1385	0.1864	*****	-0.6379
-0.400	0.1286	0.1455	0.1569	-0.0023	-0.7212
-0.600	0.1413	0.1464	0.1491	0.0321	-0.7022
-0.700	0.1606	0.1417	0.1500	0.0497	-0.6753
-0.800	0.1921	*****	0.1466	0.0701	-0.6089
-0.850	*****	0.1806	0.1560	0.0775	-0.6098
-0.900	*****	0.2082	0.1777	0.1007	-0.5972
-0.950	0.2468	0.2312	0.2118	0.1489	-0.2138
-0.975	*****	0.2113	0.2038	0.1601	-0.0585
-1.000	-0.4572	-0.7417	-1.0386	-1.0699	-0.8726

Medium Radius L.E.
 Run No. = 16, Point No. = 341
 $C_N = 0.292$, $C_m = -0.0484$
 $\alpha = 7.1^\circ$, $M_\infty = 0.849$
 $R_{mac} = 108.9 \times 10^6$



Leading Edge Pressures

● starboard
 ○ port

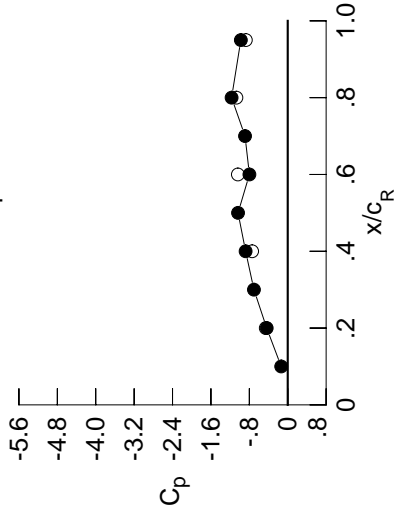

x/c_R	starb'd C_p	port C_p
0.10	-0.1361	*****
0.20	-0.4382	-0.4572
0.30	-0.7039	*****
0.40	-0.8773	-0.7417
0.50	-1.0350	*****
0.60	-0.7983	-1.0386
0.70	-0.8896	*****
0.80	-1.1697	-1.0699
0.90	*****	*****
0.95	-0.9770	-0.8726

Table E10. Continued.

η	$x/c_R = .2$		$x/c_R = .4$		$x/c_R = .6$		$x/c_R = .8$		$x/c_R = .95$	
	$C_{p,u}$	$C_{p,u}$	$C_{p,u}$	$C_{p,u}$	$C_{p,u}$	$C_{p,u}$	$C_{p,u}$	$C_{p,u}$	$C_{p,u}$	$C_{p,u}$
0.050	-0.1537	-0.1289	0.0366	*****	*****	*****	*****	*****	*****	*****
0.100	-0.1571	-0.1312	0.0266	*****	*****	*****	*****	*****	*****	*****
0.150	-0.1617	-0.1346	0.0117	*****	*****	*****	*****	*****	*****	*****
0.200	-0.1658	-0.1304	-0.0023	*****	*****	*****	*****	*****	*****	-0.3469
0.250	*****	-0.1396	-0.0204	-0.2330	-0.2330	-0.3321	-0.3321	-0.3321	-0.3321	-0.3321
0.300	-0.1811	-0.1425	-0.0317	-0.2176	-0.2176	-0.3732	-0.3732	-0.3732	-0.3732	-0.3732
0.350	*****	-0.1513	-0.0472	-0.2087	-0.2087	-0.5170	-0.5170	-0.5170	-0.5170	-0.5170
0.400	-0.2159	-0.1551	-0.0611	-0.1972	-0.1972	-0.7000	-0.7000	-0.7000	-0.7000	-0.7000
0.450	-0.2350	-0.1684	-0.0546	-0.1979	-0.1979	-0.7556	-0.7556	-0.7556	-0.7556	-0.7556
0.500	-0.2581	-0.1769	-0.0993	-0.1989	-0.1989	-0.6852	-0.6852	-0.6852	-0.6852	-0.6852
0.525	*****	-0.1905	-0.1092	-0.2040	-0.2040	-0.6107	-0.6107	-0.6107	-0.6107	-0.6107
0.550	-0.2785	-0.2069	-0.1200	-0.2116	-0.2116	-0.5002	-0.5002	-0.5002	-0.5002	-0.5002
0.575	*****	-0.2167	-0.1224	-0.2226	-0.2226	-0.4707	-0.4707	-0.4707	-0.4707	-0.4707
0.600	-0.3081	-0.2299	-0.1500	-0.2336	-0.2336	-0.4800	-0.4800	-0.4800	-0.4800	-0.4800
0.625	*****	*****	-0.1580	-0.2301	-0.2301	-0.5135	-0.5135	-0.5135	-0.5135	-0.5135
0.650	-0.3374	-0.2502	-0.1760	-0.2239	-0.2239	-0.5341	-0.5341	-0.5341	-0.5341	-0.5341
0.675	*****	-0.2766	-0.1968	-0.2260	-0.2260	-0.4830	-0.4830	-0.4830	-0.4830	-0.4830
0.700	-0.3643	-0.3011	-0.2111	-0.2224	-0.2224	-0.4791	-0.4791	-0.4791	-0.4791	-0.4791
0.725	*****	-0.3297	*****	-0.2255	-0.2255	-0.5155	-0.5155	-0.5155	-0.5155	-0.5155
0.750	-0.3920	-0.3615	*****	-0.2434	-0.2434	-0.5106	-0.5106	-0.5106	-0.5106	-0.5106
0.775	*****	-0.3978	-0.2745	-0.3293	-0.3293	-0.5404	-0.5404	-0.5404	-0.5404	-0.5404
0.800	-0.4175	-0.4391	-0.3097	-0.4352	-0.4352	*****	*****	*****	*****	*****
0.825	*****	-0.4810	-0.3498	-0.5299	-0.5299	-0.7638	-0.7638	-0.7638	-0.7638	-0.7638
0.850	-0.4445	-0.5231	-0.3974	-0.5523	-0.5523	-0.8883	-0.8883	-0.8883	-0.8883	-0.8883
0.875	*****	-0.5703	-0.5125	-0.4467	-0.4467	-1.1863	-1.1863	-1.1863	-1.1863	-1.1863
0.900	-0.4806	-0.6223	-0.7179	-0.4262	-0.4262	-1.1786	-1.1786	-1.1786	-1.1786	-1.1786
0.925	*****	-0.6772	-0.8981	-0.5903	-0.5903	-1.0744	-1.0744	-1.0744	-1.0744	-1.0744
0.950	-0.5460	-0.7228	-1.0121	-0.9881	-0.9881	-0.8502	-0.8502	-0.8502	-0.8502	-0.8502
0.975	*****	-1.0553	-1.0455	-1.0551	-1.0551	-0.8973	-0.8973	-0.8973	-0.8973	-0.8973
1.000	-0.6556	-1.0836	-0.8837	-1.2608	-1.2608	-1.1486	-1.1486	-1.1486	-1.1486	-1.1486
-0.200	$C_{p,l}$	0.1640	0.1628	0.2057	*****	-0.6356	-0.6356	-0.6356	-0.6356	-0.6356
-0.400	$C_{p,l}$	0.1565	0.1706	0.1773	0.0157	-0.7149	-0.7149	-0.7149	-0.7149	-0.7149
-0.600	$C_{p,l}$	0.1716	0.1731	0.1703	0.0499	-0.6905	-0.6905	-0.6905	-0.6905	-0.6905
-0.700	$C_{p,l}$	0.1916	0.1701	0.1740	0.0684	-0.6622	-0.6622	-0.6622	-0.6622	-0.6622
-0.800	$C_{p,l}$	0.2210	*****	0.1724	0.0911	-0.5919	-0.5919	-0.5919	-0.5919	-0.5919
-0.850	$C_{p,l}$	*****	0.2099	0.1835	0.1007	-0.5931	-0.5931	-0.5931	-0.5931	-0.5931
-0.900	$C_{p,l}$	*****	0.2331	0.2039	0.1247	-0.5759	-0.5759	-0.5759	-0.5759	-0.5759
-0.950	$C_{p,l}$	0.2511	0.2414	0.2266	0.1658	-0.2074	-0.2074	-0.2074	-0.2074	-0.2074
-0.975	$C_{p,l}$	*****	0.1984	0.2007	0.1648	-0.0637	-0.0637	-0.0637	-0.0637	-0.0637
-1.000	$C_{p,l}$	-0.6824	-0.9313	-1.1601	-1.1224	-0.9452	-0.9452	-0.9452	-0.9452	-0.9452

Medium Radius L.E.

Run No. = 16, Point No. = 342

$C_N = 0.358$, $C_m = -0.0650$

$\alpha = 8.2^\circ$, $M_\infty = 0.849$

$R_{mac} = 108.8 \times 10^6$

Leading Edge Pressures

● starboard
○ port

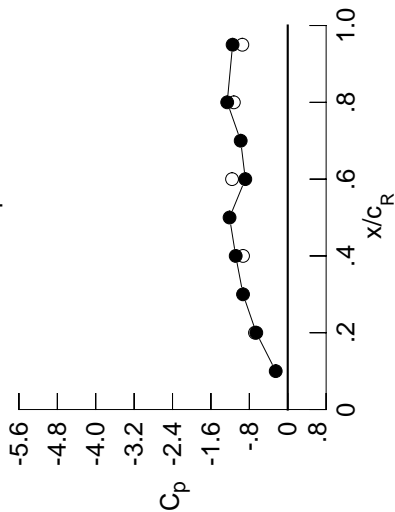

x/c_R	starb'd C_p	port C_p
0.10	-0.2502	*****
0.20	-0.6556	-0.6824
0.30	-0.9310	*****
0.40	-1.0836	-0.9313
0.50	-1.2119	*****
0.60	-0.8837	-1.1601
0.70	-0.9803	*****
0.80	-1.2608	-1.1224
0.90	*****	*****
0.95	-1.1486	-0.9452

Surface Pressures

● upper, starboard
○ lower, port

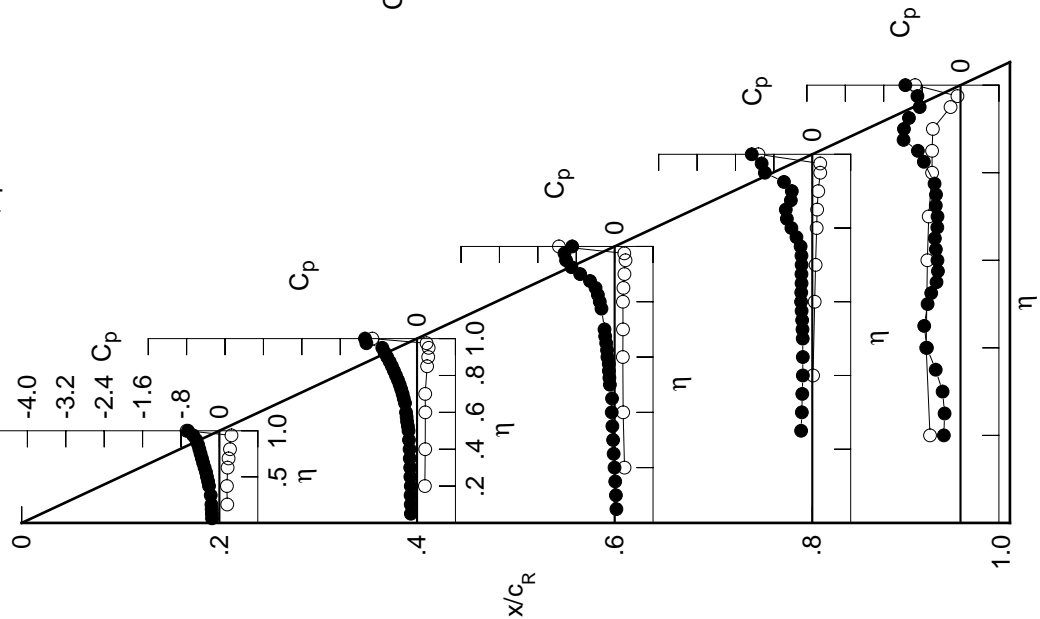
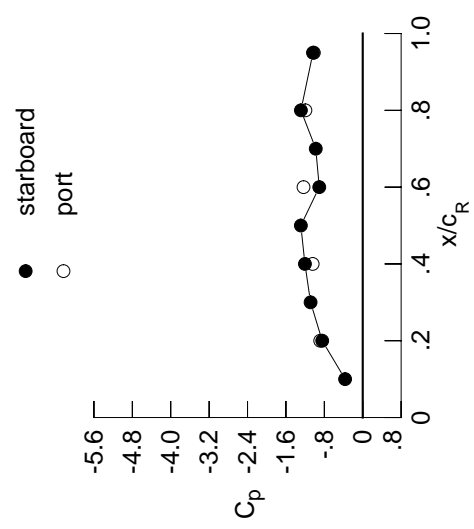

Table E10. Continued.

η	$x/c_R = .2$		$x/c_R = .4$		$x/c_R = .6$		$x/c_R = .8$		$x/c_R = .95$	
	$C_{p,u}$	$C_{p,u}$	$C_{p,u}$	$C_{p,u}$	$C_{p,u}$	$C_{p,u}$	$C_{p,u}$	$C_{p,u}$	$C_{p,u}$	$C_{p,u}$
0.050	-0.1705	-0.1509	0.0197	*****	*****	*****	*****	*****	*****	*****
0.100	-0.1761	-0.1548	0.0095	*****	*****	*****	*****	*****	*****	*****
0.150	-0.1821	-0.1575	-0.0062	*****	*****	*****	*****	*****	*****	*****
0.200	-0.1872	-0.1553	-0.0205	*****	*****	*****	*****	*****	*****	-0.3827
0.250	*****	-0.1646	-0.0388	-0.2376	-0.3477	*****	*****	*****	*****	*****
0.300	-0.2024	-0.1690	-0.0486	-0.2173	-0.4887	*****	*****	*****	*****	*****
0.350	*****	-0.1773	-0.0638	-0.2078	-0.6475	*****	*****	*****	*****	*****
0.400	-0.2394	-0.1824	-0.0842	-0.1968	-0.6818	*****	*****	*****	*****	*****
0.450	-0.2607	-0.1981	-0.0861	-0.2051	-0.5840	*****	*****	*****	*****	*****
0.500	-0.2857	-0.2159	-0.1317	-0.2129	-0.6092	*****	*****	*****	*****	*****
0.525	*****	-0.2323	-0.1467	-0.2013	-0.6671	*****	*****	*****	*****	*****
0.550	-0.3094	-0.2480	-0.1623	-0.1929	-0.6630	*****	*****	*****	*****	*****
0.575	*****	-0.2590	-0.1673	-0.1855	-0.6437	*****	*****	*****	*****	*****
0.600	-0.3427	-0.2728	-0.1863	-0.1828	-0.5929	*****	*****	*****	*****	*****
0.625	*****	*****	-0.1790	-0.1711	-0.5226	*****	*****	*****	*****	*****
0.650	-0.3757	-0.2936	-0.1808	-0.1587	-0.4454	*****	*****	*****	*****	*****
0.675	*****	-0.3186	-0.1882	-0.1502	-0.3639	*****	*****	*****	*****	*****
0.700	-0.4084	-0.3419	-0.1871	-0.1326	-0.3434	*****	*****	*****	*****	*****
0.725	*****	-0.3705	*****	-0.1651	-0.3674	*****	*****	*****	*****	*****
0.750	-0.4428	-0.4036	*****	-0.3781	-0.3735	*****	*****	*****	*****	*****
0.775	*****	-0.4417	-0.1749	-0.7415	-0.3437	*****	*****	*****	*****	*****
0.800	-0.4740	-0.4846	-0.4838	-0.8538	*****	*****	*****	*****	*****	*****
0.825	*****	-0.5257	-0.8772	-0.9088	-0.3669	*****	*****	*****	*****	*****
0.850	-0.5170	-0.5702	-0.9814	-0.7057	-0.4313	*****	*****	*****	*****	*****
0.875	*****	-0.6265	-0.9949	-0.4839	-0.6578	*****	*****	*****	*****	*****
0.900	-0.5648	-0.7223	-0.9665	-0.4631	-0.8791	*****	*****	*****	*****	*****
0.925	*****	-0.8913	-0.9308	-0.4088	-0.8668	*****	*****	*****	*****	*****
0.950	-0.6512	-1.0976	-0.8889	-1.0043	-0.7411	*****	*****	*****	*****	*****
0.975	*****	-1.2727	-0.8843	-0.8910	-0.7061	*****	*****	*****	*****	*****
1.000	-0.8439	-1.2042	-0.9056	-1.2879	-1.0361	*****	*****	*****	*****	*****
-0.200	$C_{p,l}$	0.1897	0.1862	0.2224	*****	*****	*****	*****	*****	-0.6300
-0.400	*****	0.1845	0.1939	0.1942	0.0299	-0.7058	*****	*****	*****	*****
-0.600	*****	0.2013	0.1984	0.1885	0.0642	-0.6792	*****	*****	*****	*****
-0.700	*****	0.2217	0.1974	0.1930	0.0837	-0.6492	*****	*****	*****	*****
-0.800	*****	0.2487	*****	0.1923	0.1074	-0.5780	*****	*****	*****	*****
-0.850	*****	*****	0.2362	0.2030	0.1183	-0.5770	*****	*****	*****	*****
-0.900	*****	*****	0.2544	0.2205	0.1426	-0.5542	*****	*****	*****	*****
-0.950	*****	0.2517	0.2483	0.2299	0.1763	-0.1993	*****	*****	*****	*****
-0.975	*****	*****	0.1846	0.1875	0.1611	-0.0665	*****	*****	*****	*****
-1.000	*****	-0.8852	-1.0430	-1.2333	-1.1946	-1.0186	*****	*****	*****	*****

Medium Radius L.E.
 Run No. = 16 , Point No. = 343
 $C_N = 0.404$, $C_m = -0.0693$
 $\alpha = 9.3^\circ$, $M_\infty = 0.850$
 $R_{mac} = 108.8 \times 10^6$

Leading Edge Pressures



x/c_R	starb'd C_p	port C_p
0.10	-0.3669	*****
0.20	-0.8439	-0.8852
0.30	-1.0867	*****
0.40	-1.2042	-1.0430
0.50	-1.2891	*****
0.60	-0.9056	-1.2333
0.70	-0.9783	*****
0.80	-1.2879	-1.1946
0.90	*****	*****
0.95	-1.0361	-1.0186

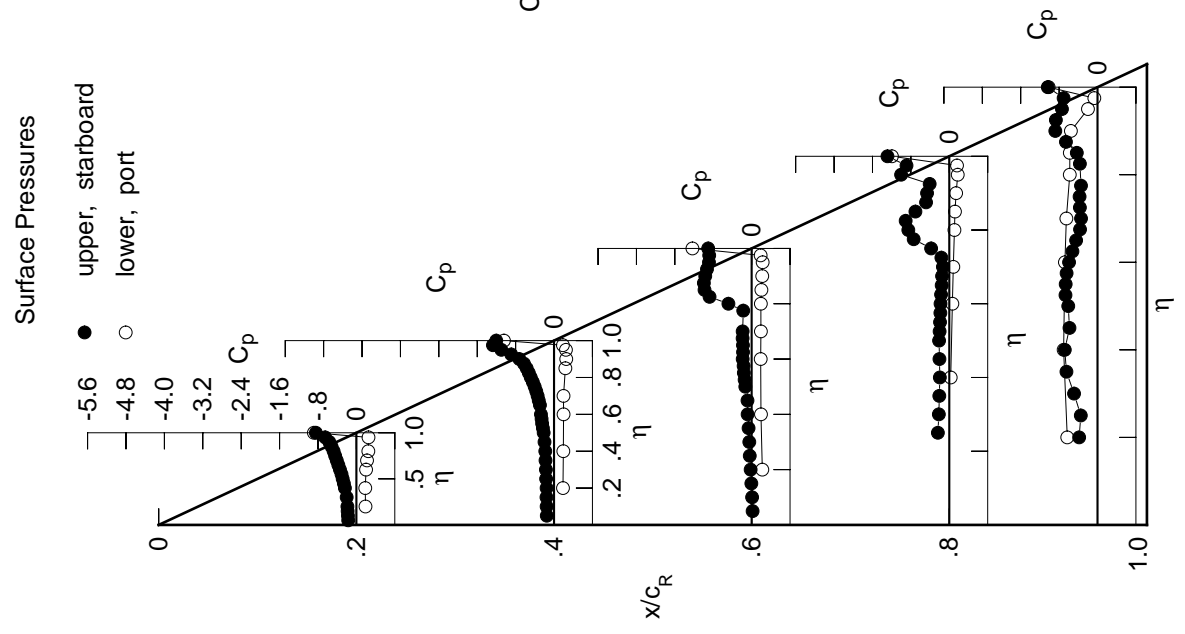
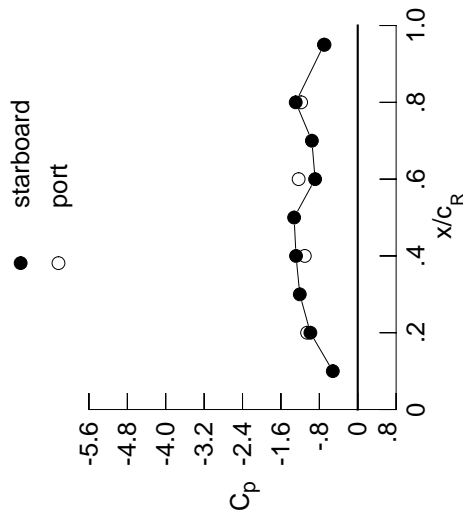

Table E10. Continued.

η	$x/c_R = .2$		$x/c_R = .4$		$x/c_R = .6$		$x/c_R = .8$		$x/c_R = .95$	
	$C_{p,u}$	$C_{p,l}$	$C_{p,u}$	$C_{p,l}$	$C_{p,u}$	$C_{p,l}$	$C_{p,u}$	$C_{p,l}$	$C_{p,u}$	$C_{p,l}$
0.050	-0.1865	-0.1814	-0.0070	*****	*****	*****	*****	*****	*****	*****
0.100	-0.1944	-0.1860	-0.0180	*****	*****	*****	*****	*****	*****	*****
0.150	-0.2030	-0.1890	-0.0347	*****	*****	*****	*****	*****	*****	*****
0.200	-0.2091	-0.1880	-0.0481	*****	*****	*****	*****	*****	*****	*****
0.250	*****	-0.1970	-0.0620	-0.2753	-0.3454	*****	*****	*****	*****	*****
0.300	-0.2267	-0.2000	-0.0779	-0.2571	-0.4168	*****	*****	*****	*****	*****
0.350	*****	-0.2106	-0.1006	-0.2549	-0.3803	*****	*****	*****	*****	*****
0.400	-0.2652	-0.2260	-0.1290	-0.2576	-0.3421	*****	*****	*****	*****	*****
0.450	-0.2877	-0.2473	-0.1380	-0.2366	-0.5021	*****	*****	*****	*****	*****
0.500	-0.3153	-0.2646	-0.1580	-0.2248	-0.7012	*****	*****	*****	*****	*****
0.525	*****	-0.2781	-0.1577	-0.2222	-0.7043	*****	*****	*****	*****	*****
0.550	-0.3425	-0.2970	-0.1577	-0.2167	-0.6781	*****	*****	*****	*****	*****
0.575	*****	-0.3063	-0.1485	-0.2117	-0.6614	*****	*****	*****	*****	*****
0.600	-0.3789	-0.3152	-0.1701	-0.2080	-0.6171	*****	*****	*****	*****	*****
0.625	*****	*****	-0.1644	-0.1978	-0.5718	*****	*****	*****	*****	*****
0.650	-0.4167	-0.3224	-0.1623	-0.2073	-0.5547	*****	*****	*****	*****	*****
0.675	*****	-0.3427	-0.1599	-0.2752	-0.5480	*****	*****	*****	*****	*****
0.700	-0.4568	-0.3568	-0.1495	-0.4436	-0.5972	*****	*****	*****	*****	*****
0.725	*****	-0.3796	*****	-0.7062	-0.6607	*****	*****	*****	*****	*****
0.750	-0.4996	-0.4074	*****	-0.9167	-0.6612	*****	*****	*****	*****	*****
0.775	*****	-0.4614	-1.0350	-1.0371	-0.5782	*****	*****	*****	*****	*****
0.800	-0.5496	-0.5969	-1.1182	-1.0186	*****	*****	*****	*****	*****	*****
0.825	*****	-0.8114	-1.0884	-0.9376	-0.5140	*****	*****	*****	*****	*****
0.850	-0.5878	-0.9749	-1.0436	-0.7149	-0.5137	*****	*****	*****	*****	*****
0.875	*****	-1.0620	-1.0002	-0.6328	-0.5659	*****	*****	*****	*****	*****
0.900	-0.6517	-1.1219	-0.9171	-0.6069	-0.6217	*****	*****	*****	*****	*****
0.925	*****	-1.1343	-0.8406	-0.5716	-0.6188	*****	*****	*****	*****	*****
0.950	-0.7697	-1.1383	-0.7933	-0.8339	-0.5448	*****	*****	*****	*****	*****
0.975	*****	-1.1317	-0.7675	-0.7509	-0.4914	*****	*****	*****	*****	*****
1.000	-0.9867	-1.2855	-0.8884	-1.2918	-0.7042	*****	*****	*****	*****	*****
-0.200	$C_{p,l}$	$C_{p,l}$	$C_{p,l}$	$C_{p,l}$	$C_{p,l}$	$C_{p,l}$	$C_{p,l}$	$C_{p,l}$	$C_{p,l}$	$C_{p,l}$
-0.400	0.2213	0.2127	0.2420	*****	*****	*****	*****	*****	*****	*****
-0.600	0.2165	0.2216	0.2150	0.0464	-0.6965	*****	*****	*****	*****	*****
-0.700	0.2347	0.2266	0.2102	0.0800	-0.6701	*****	*****	*****	*****	*****
-0.800	0.2547	0.2276	0.2164	0.1004	-0.6398	*****	*****	*****	*****	*****
-0.850	0.2783	*****	0.2177	0.1247	-0.5674	*****	*****	*****	*****	*****
-0.900	*****	0.2644	0.2287	0.1364	-0.5640	*****	*****	*****	*****	*****
-0.950	*****	0.2773	0.2441	0.1588	-0.5347	*****	*****	*****	*****	*****
-0.975	0.2513	0.2571	0.2444	0.1843	-0.1834	*****	*****	*****	*****	*****
-1.000	*****	0.1752	0.1908	0.1581	-0.0463	*****	*****	*****	*****	*****
-1.000	-1.0549	-1.1024	-1.2313	-1.1792	-0.6920	*****	*****	*****	*****	*****

Medium Radius L.E.
 Run No. = 16 , Point No. = 344
 $C_N = 0.473$, $C_m = -0.0805$
 $\alpha = 10.4^\circ$, $M_\infty = 0.850$
 $R_{mac} = 108.8 \times 10^6$

Leading Edge Pressures



x/c_R	starb'd C_p	port C_p
0.10	-0.5188	*****
0.20	-0.9867	-1.0549
0.30	-1.2073	*****
0.40	-1.2855	-1.1024
0.50	-1.3254	*****
0.60	-0.8884	-1.2313
0.70	-0.9554	*****
0.80	-1.2918	-1.1792
0.90	*****	*****
0.95	-0.7042	-0.6920

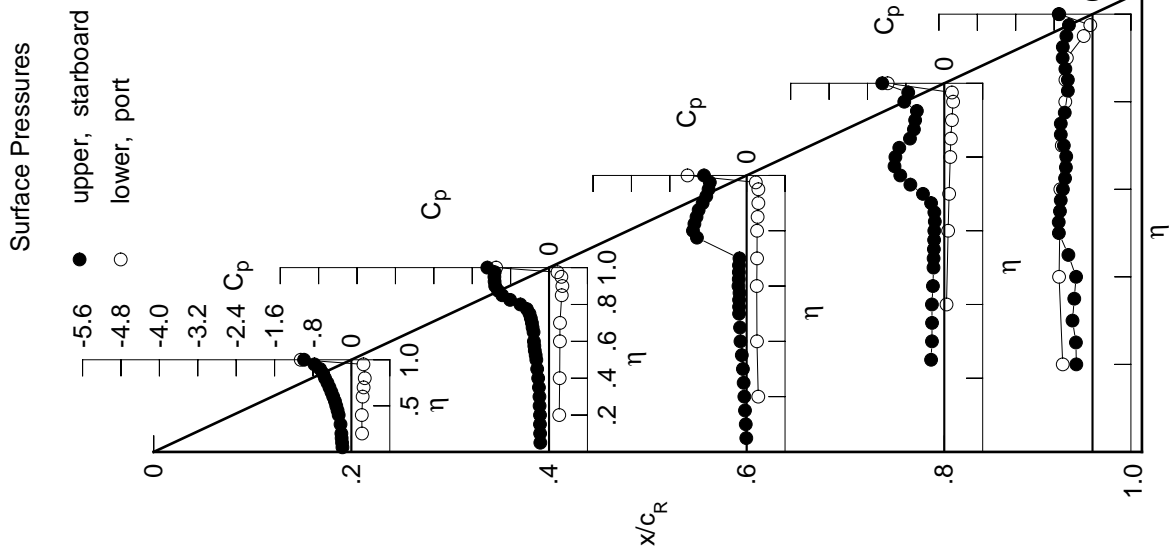

Table E10. Continued.

η	$x/c_R = .2$		$x/c_R = .4$		$x/c_R = .6$		$x/c_R = .8$		$x/c_R = .95$	
	$C_{p,u}$	$C_{p,u}$	$C_{p,u}$	$C_{p,u}$	$C_{p,u}$	$C_{p,u}$	$C_{p,u}$	$C_{p,u}$	$C_{p,u}$	$C_{p,u}$
0.050	-0.2046	-0.2153	-0.0313	*****	*****	*****	*****	*****	*****	
0.100	-0.2133	-0.2181	-0.0424	*****	*****	*****	*****	*****	*****	
0.150	-0.2254	-0.2233	-0.0601	*****	*****	*****	*****	*****	*****	
0.200	-0.2323	-0.2222	-0.0680	*****	*****	*****	*****	*****	-0.3339	
0.250	*****	-0.2277	-0.0910	-0.3079	-0.3079	-0.3663	*****	*****	*****	
0.300	-0.2533	-0.2383	-0.1085	-0.2959	-0.4509	*****	*****	*****	*****	
0.350	*****	-0.2537	-0.1406	-0.2919	-0.4644	*****	*****	*****	*****	
0.400	-0.2944	-0.2756	-0.1459	-0.2742	-0.5460	*****	*****	*****	*****	
0.450	-0.3187	-0.2934	-0.1271	-0.2650	-0.7119	*****	*****	*****	*****	
0.500	-0.3483	-0.2963	-0.1662	-0.2517	-0.7270	*****	*****	*****	*****	
0.525	*****	-0.3018	-0.1701	-0.2474	-0.7127	*****	*****	*****	*****	
0.550	-0.3774	-0.3075	-0.1692	-0.2401	-0.6921	*****	*****	*****	*****	
0.575	*****	-0.3070	-0.1501	-0.2407	-0.6905	*****	*****	*****	*****	
0.600	-0.4154	-0.3095	-0.1682	-0.2572	-0.6960	*****	*****	*****	*****	
0.625	*****	*****	-0.1662	-0.3031	-0.7444	*****	*****	*****	*****	
0.650	-0.4584	-0.3337	-0.2447	-0.4264	-0.8674	*****	*****	*****	*****	
0.675	*****	-0.4087	-0.4490	-0.6445	-0.9912	*****	*****	*****	*****	
0.700	-0.5051	-0.4492	-0.6967	-0.8667	-1.0836	*****	*****	*****	*****	
0.725	*****	-0.4972	*****	-1.0185	-1.1041	*****	*****	*****	*****	
0.750	-0.5608	-0.6267	*****	-1.0584	-0.9867	*****	*****	*****	*****	
0.775	*****	-0.8742	-1.0580	-1.0681	-0.7948	*****	*****	*****	*****	
0.800	-0.5985	-1.0525	-1.0319	-1.0129	*****	*****	*****	*****	*****	
0.825	*****	-1.1101	-1.0057	-0.9459	-0.6100	*****	*****	*****	*****	
0.850	-0.6444	-1.1286	-0.9623	-0.8004	-0.5574	*****	*****	*****	*****	
0.875	*****	-1.1376	-0.9328	-0.7331	-0.5337	*****	*****	*****	*****	
0.900	-0.7622	-1.1312	-0.8911	-0.7060	-0.5207	*****	*****	*****	*****	
0.925	*****	-1.1042	-0.8513	-0.6751	-0.5181	*****	*****	*****	*****	
0.950	-1.1652	-1.0842	-0.8181	-0.7322	-0.4720	*****	*****	*****	*****	
0.975	*****	-1.0645	-0.7901	-0.6533	-0.4220	*****	*****	*****	*****	
1.000	-1.1043	-1.3426	-0.8791	-1.1035	-0.5687	*****	*****	*****	*****	
	$C_{p,l}$	$C_{p,l}$	$C_{p,l}$	$C_{p,l}$	$C_{p,l}$	$C_{p,l}$	$C_{p,l}$	$C_{p,l}$	$C_{p,l}$	
-0.200	0.2514	0.2387	0.2603	*****	-0.6087	*****	*****	*****	*****	
-0.400	0.2486	0.2474	0.2348	0.0622	-0.6855	*****	*****	*****	*****	
-0.600	0.2674	0.2535	0.2304	0.0959	-0.6601	*****	*****	*****	*****	
-0.700	0.2866	0.2555	0.2372	0.1155	-0.6297	*****	*****	*****	*****	
-0.800	0.3061	*****	0.2390	0.1402	-0.5552	*****	*****	*****	*****	
-0.850	*****	0.2886	0.2491	0.1508	-0.5502	*****	*****	*****	*****	
-0.900	*****	0.2953	0.2611	0.1719	-0.5160	*****	*****	*****	*****	
-0.950	0.2492	0.2608	0.2496	0.1877	-0.1750	*****	*****	*****	*****	
-0.975	*****	0.1614	0.1831	0.1482	-0.0462	*****	*****	*****	*****	
-1.000	-1.1294	-1.1411	-1.1315	-1.1431	-0.6363	*****	*****	*****	*****	

Medium Radius L.E.
 Run No. = 16, Point No. = 345
 $C_N = 0.542$, $C_m = -0.0924$
 $\alpha = 11.4^\circ$, $M_\infty = 0.851$
 $R_{mac} = 108.8 \times 10^6$

Leading Edge Pressures

● starboard
 ○ port

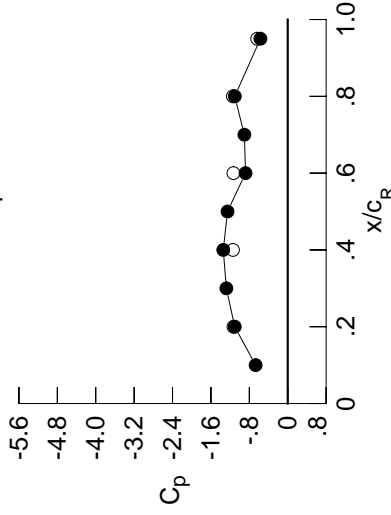

x/c_R	starb'd C_p	port C_p
0.10	-0.6685	*****
0.20	-1.1043	-1.1294
0.30	-1.2786	*****
0.40	-1.3426	-1.1411
0.50	-1.2548	*****
0.60	-0.8791	-1.1315
0.70	-0.9035	*****
0.80	-1.1035	-1.1431
0.90	*****	*****
0.95	-0.5687	-0.6363

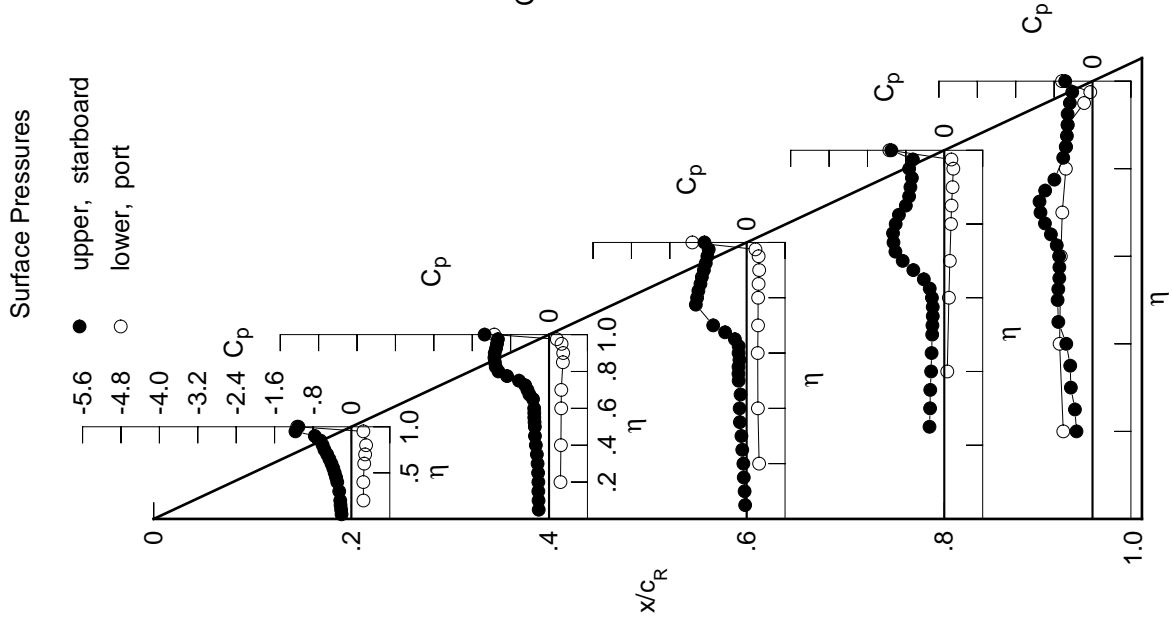

Table E10. Continued.

η	$x/c_R = .2$		$x/c_R = .4$		$x/c_R = .6$		$x/c_R = .8$		$x/c_R = .95$	
	$C_{p,u}$	$C_{p,u}$	$C_{p,u}$	$C_{p,u}$	$C_{p,u}$	$C_{p,u}$	$C_{p,u}$	$C_{p,u}$	$C_{p,u}$	$C_{p,u}$
0.050	-0.2271	-0.2501	-0.0532	*****	*****	*****	*****	*****	*****	*****
0.100	-0.2329	-0.2511	-0.0635	*****	*****	*****	*****	*****	*****	*****
0.150	-0.2495	-0.2559	-0.0802	*****	*****	*****	*****	*****	*****	*****
0.200	-0.2602	-0.2531	-0.0932	*****	*****	*****	*****	*****	*****	-0.4411
0.250	*****	-0.2631	-0.1133	-0.3300	-0.3300	-0.4437	*****	*****	*****	-0.4437
0.300	-0.2852	-0.2746	-0.1382	-0.3226	-0.3226	-0.4619	*****	*****	*****	-0.4619
0.350	*****	-0.3001	-0.1748	-0.3171	-0.3171	-0.4389	*****	*****	*****	-0.4389
0.400	-0.3318	-0.3126	-0.1750	-0.2926	-0.2926	-0.5321	*****	*****	*****	-0.5321
0.450	-0.3532	-0.3458	-0.1548	-0.2809	-0.2809	-0.6961	*****	*****	*****	-0.6961
0.500	-0.3806	-0.3532	-0.1755	-0.2673	-0.2673	-0.7023	*****	*****	*****	-0.7023
0.525	*****	-0.3484	-0.1733	-0.2659	-0.2659	-0.6915	*****	*****	*****	-0.6915
0.550	-0.4099	-0.3545	-0.1700	-0.2649	-0.2649	-0.6754	*****	*****	*****	-0.6754
0.575	*****	-0.3498	-0.1506	-0.2772	-0.2772	-0.6847	*****	*****	*****	-0.6847
0.600	-0.4504	-0.3437	-0.1872	-0.3130	-0.3130	-0.7056	*****	*****	*****	-0.7056
0.625	*****	*****	-0.2253	-0.3916	-0.3916	-0.7760	*****	*****	*****	-0.7760
0.650	-0.4961	-0.3140	-0.3980	-0.5487	-0.5487	-0.9129	*****	*****	*****	-0.9129
0.675	*****	-0.3087	-0.7021	-0.7852	-1.0508	*****	*****	*****	*****	-1.0508
0.700	-0.5460	-0.3045	-0.9651	-1.0210	-1.0484	*****	*****	*****	*****	-1.0484
0.725	*****	-0.6020	*****	-1.2074	-0.7309	*****	*****	*****	*****	-0.7309
0.750	-0.5863	-1.1583	*****	-1.3032	-0.6354	*****	*****	*****	*****	-0.6354
0.775	*****	-1.3375	-1.2686	-1.1076	-0.5673	*****	*****	*****	*****	-0.5673
0.800	-0.6320	-1.3625	-1.1860	-0.9126	*****	*****	*****	*****	*****	-0.9126
0.825	*****	-1.3151	-1.1352	-0.8267	-0.5449	*****	*****	*****	*****	-0.5449
0.850	-0.8715	-1.2719	-1.0517	-0.7992	-0.5151	*****	*****	*****	*****	-0.5151
0.875	*****	-1.2296	-0.9596	-0.7957	-0.5324	*****	*****	*****	*****	-0.5324
0.900	-1.1279	-1.1758	-0.8988	-0.7460	-0.5591	*****	*****	*****	*****	-0.5591
0.925	*****	-1.1373	-0.8563	-0.7154	-0.5626	*****	*****	*****	*****	-0.5626
0.950	-1.2731	-1.0988	-0.8125	-0.7730	-0.4813	*****	*****	*****	*****	-0.4813
0.975	*****	-1.0777	-0.7860	-0.6894	-0.4101	*****	*****	*****	*****	-0.4101
1.000	-1.1963	-1.3818	-0.8533	-1.0931	-0.5241	*****	*****	*****	*****	-0.5241
-0.200	$C_{p,l}$	$C_{p,l}$	$C_{p,l}$	$C_{p,l}$	$C_{p,l}$	$C_{p,l}$	$C_{p,l}$	$C_{p,l}$	$C_{p,l}$	$C_{p,l}$
-0.400	0.2815	0.2634	0.2776	*****	*****	-0.5984	*****	*****	*****	-0.5984
-0.600	0.2797	0.2722	0.2526	0.0773	0.0773	-0.6771	*****	*****	*****	-0.6771
-0.700	0.2988	0.2785	0.2487	0.1101	-0.6520	*****	*****	*****	*****	-0.6520
-0.800	0.3167	0.2809	0.2565	0.1306	-0.6204	*****	*****	*****	*****	-0.6204
-0.850	0.3321	*****	0.2574	0.1542	-0.5454	*****	*****	*****	*****	-0.5454
-0.900	*****	0.3099	0.2661	0.1656	-0.5370	*****	*****	*****	*****	-0.5370
-0.950	*****	0.3101	0.2740	0.1853	-0.4983	*****	*****	*****	*****	-0.4983
-0.975	0.2470	0.2625	0.2502	0.1920	-0.1659	*****	*****	*****	*****	-0.1659
-1.000	*****	0.1468	0.1697	0.1391	-0.0447	*****	*****	*****	*****	-0.0447
-1.000	-1.1884	-1.1410	-1.0439	-1.0593	-0.5570	*****	*****	*****	*****	-0.5570

Medium Radius L.E.
 Run No. = 16 , Point No. = 346
 $C_N = 0.598$, $C_m = -0.0989$
 $\alpha = 12.5^\circ$, $M_\infty = 0.849$
 $R_{mac} = 108.6 \times 10^6$

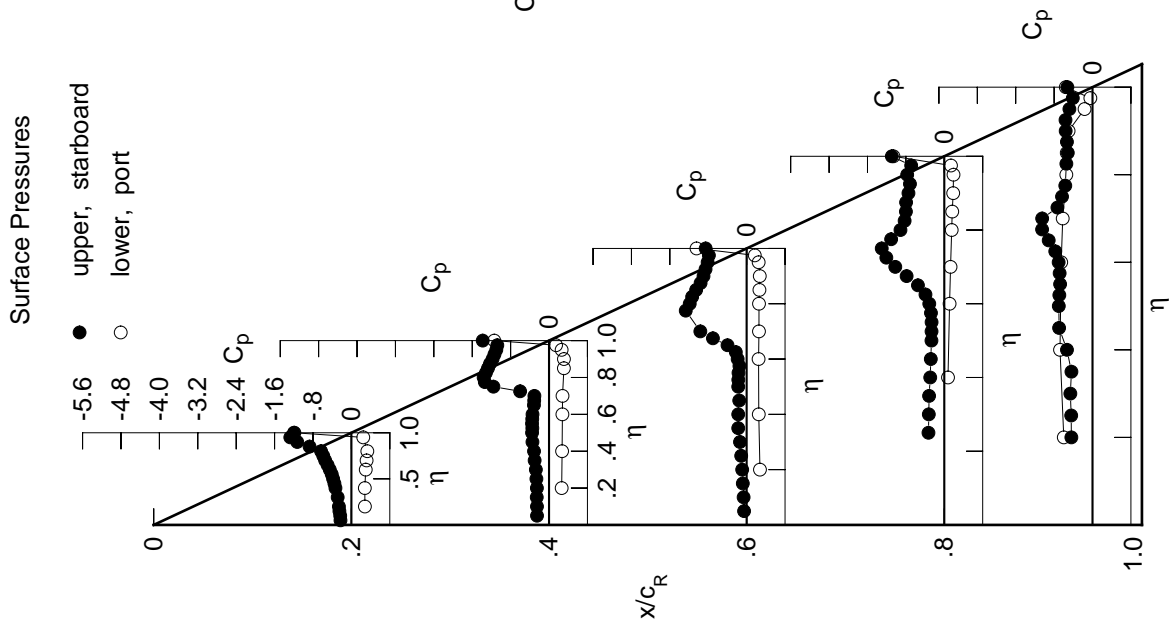
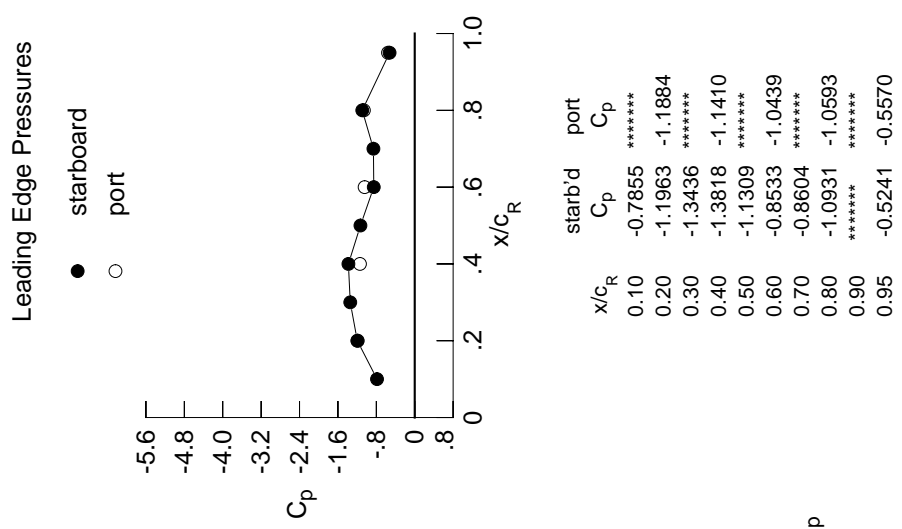
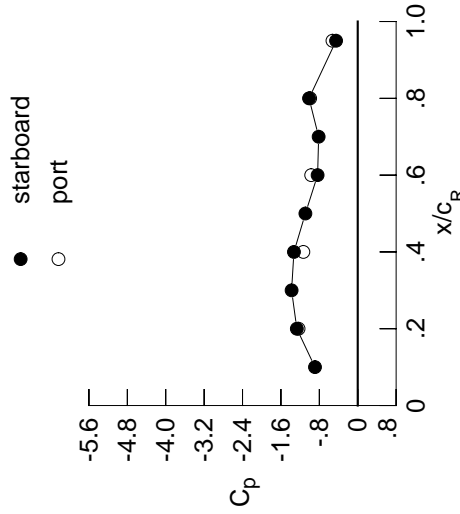

Table E10. Continued.

η	$x/c_R = .2$		$x/c_R = .4$		$x/c_R = .6$		$x/c_R = .8$		$x/c_R = .95$	
	$C_{p,u}$	$C_{p,u}$	$C_{p,u}$	$C_{p,u}$	$C_{p,u}$	$C_{p,u}$	$C_{p,u}$	$C_{p,u}$	$C_{p,u}$	$C_{p,u}$
0.050	-0.2529	-0.2930	-0.0745	*****	*****	*****	*****	*****	*****	*****
0.100	-0.2536	-0.2938	-0.0856	*****	*****	*****	*****	*****	*****	*****
0.150	-0.2718	-0.2955	-0.1005	*****	*****	*****	*****	*****	*****	*****
0.200	-0.2870	-0.2928	-0.1135	*****	*****	*****	*****	*****	*****	*****
0.250	*****	-0.3057	-0.1376	-0.3633	-0.4194	*****	*****	*****	*****	*****
0.300	-0.3291	-0.3321	-0.1545	-0.3473	-0.4890	*****	*****	*****	*****	*****
0.350	*****	-0.3449	-0.1788	-0.3401	-0.5354	*****	*****	*****	*****	*****
0.400	-0.3655	-0.3374	-0.2008	-0.3263	-0.5839	*****	*****	*****	*****	*****
0.450	-0.3825	-0.3561	-0.1893	-0.3210	-0.6351	*****	*****	*****	*****	*****
0.500	-0.4082	-0.3978	-0.2268	-0.3183	-0.6681	*****	*****	*****	*****	*****
0.525	*****	-0.4218	-0.2351	-0.3271	-0.6869	*****	*****	*****	*****	*****
0.550	-0.4378	-0.4310	-0.2517	-0.3514	-0.7087	*****	*****	*****	*****	*****
0.575	*****	-0.4272	-0.2839	-0.4081	-0.7768	*****	*****	*****	*****	*****
0.600	-0.4794	-0.4335	-0.4183	-0.5103	-0.8665	*****	*****	*****	*****	*****
0.625	*****	*****	-0.5580	-0.6617	-0.9899	*****	*****	*****	*****	*****
0.650	-0.5156	-0.4684	-0.8045	-0.8598	-1.1408	*****	*****	*****	*****	*****
0.675	*****	-0.5891	-1.0379	-1.0635	-1.2216	*****	*****	*****	*****	*****
0.700	-0.5487	-0.8607	-1.1766	-1.2213	-0.9246	*****	*****	*****	*****	*****
0.725	*****	-1.1534	*****	-1.3275	-0.8253	*****	*****	*****	*****	*****
0.750	-0.6598	-1.3041	*****	-1.2967	-0.7307	*****	*****	*****	*****	*****
0.775	*****	-1.3247	-1.2561	-1.0750	-0.6279	*****	*****	*****	*****	*****
0.800	-0.9859	-1.2995	-1.1943	-0.9299	*****	*****	*****	*****	*****	*****
0.825	*****	-1.2680	-1.1200	-0.8537	-0.5354	*****	*****	*****	*****	*****
0.850	-1.2020	-1.2349	-1.0130	-0.8253	-0.4993	*****	*****	*****	*****	*****
0.875	*****	-1.1982	-0.9509	-0.8163	-0.5030	*****	*****	*****	*****	*****
0.900	-1.2713	-1.1536	-0.9136	-0.7876	-0.5030	*****	*****	*****	*****	*****
0.925	*****	-1.1210	-0.8727	-0.7365	-0.4975	*****	*****	*****	*****	*****
0.950	-1.2852	-1.0893	-0.8262	-0.7616	-0.4348	*****	*****	*****	*****	*****
0.975	*****	-1.0640	-0.7943	-0.6805	-0.3655	*****	*****	*****	*****	*****
1.000	-1.2686	-1.3290	-0.8359	-1.0145	-0.4508	*****	*****	*****	*****	*****
-0.200	$C_{p,l}$	0.3154	0.2914	0.2993	*****	*****	*****	*****	*****	*****
-0.400	*****	0.3141	0.3001	0.2746	0.0947	-0.6647	*****	*****	*****	*****
-0.600	*****	0.3329	0.3062	0.2711	0.1289	-0.6412	*****	*****	*****	*****
-0.700	*****	0.3487	0.3083	0.2783	0.1486	-0.6087	*****	*****	*****	*****
-0.800	*****	0.3594	*****	0.2791	0.1727	-0.5318	*****	*****	*****	*****
-0.850	*****	0.3321	0.2862	0.1821	-0.5217	*****	*****	*****	*****	*****
-0.900	*****	0.3255	0.2887	0.1996	-0.4794	*****	*****	*****	*****	*****
-0.950	*****	0.2467	0.2639	0.2523	0.1950	-0.1568	*****	*****	*****	*****
-0.975	*****	0.1312	0.1571	0.1283	-0.0467	*****	*****	*****	*****	*****
-1.000	*****	-1.2330	-1.1327	-0.9697	-0.9909	-0.5266	*****	*****	*****	*****

Medium Radius L.E.
 Run No. = 16 , Point No. = 347
 $C_N = 0.659$, $C_m = -0.1070$
 $\alpha = 13.6^\circ$, $M_\infty = 0.850$
 $R_{mac} = 108.7 \times 10^6$

Leading Edge Pressures



x/c_R	starb'd C_p	port C_p
0.10	-0.8906	*****
0.20	-1.2686	-1.2330
0.30	-1.3780	*****
0.40	-1.3290	-1.1327
0.50	-1.0903	*****
0.60	-0.8359	-0.9697
0.70	-0.8143	*****
0.80	-1.0145	-0.9909
0.90	*****	*****
0.95	-0.4508	-0.5266

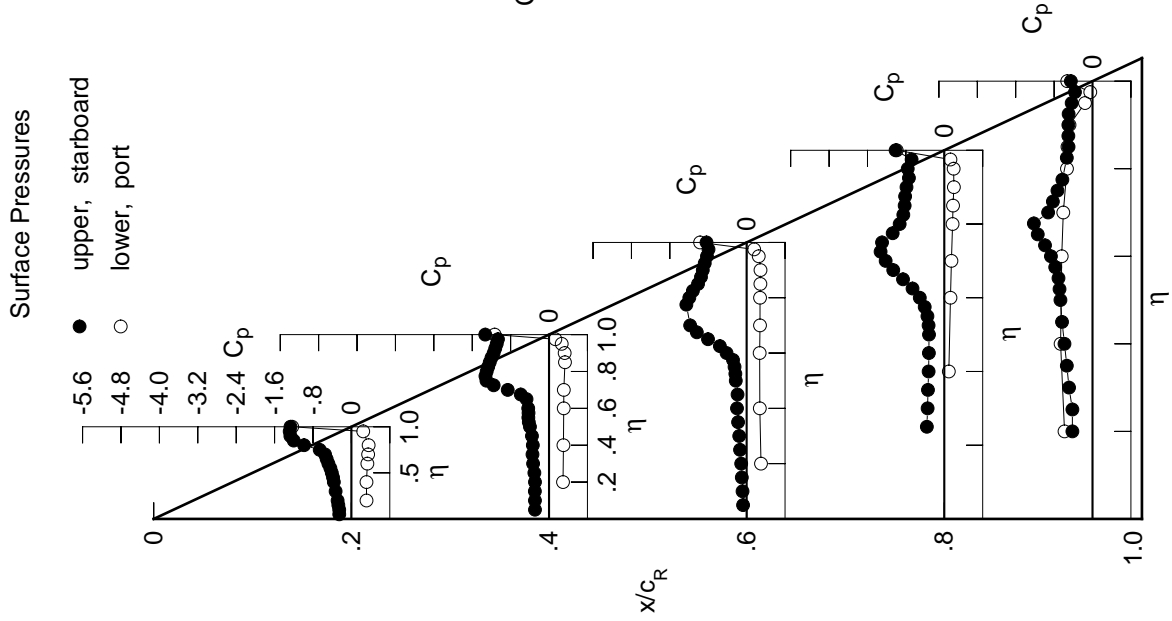
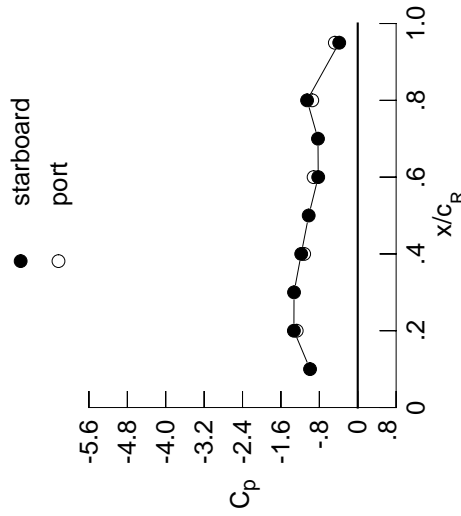

Table E10. Continued.

η	$x/c_R = .2$		$x/c_R = .4$		$x/c_R = .6$		$x/c_R = .8$		$x/c_R = .95$	
	$C_{p,u}$	$C_{p,u}$	$C_{p,u}$	$C_{p,u}$	$C_{p,u}$	$C_{p,u}$	$C_{p,u}$	$C_{p,u}$	$C_{p,u}$	$C_{p,u}$
0.050	-0.2776	-0.3345	-0.0923	*****	*****	*****	*****	*****	*****	*****
0.100	-0.2741	-0.3365	-0.1027	*****	*****	*****	*****	*****	*****	*****
0.150	-0.2898	-0.3367	-0.1189	*****	*****	*****	*****	*****	*****	*****
0.200	-0.3086	-0.3344	-0.1356	*****	*****	*****	*****	*****	*****	*****
0.250	*****	-0.3677	-0.1657	-0.3773	-0.3773	-0.5284	*****	*****	*****	*****
0.300	-0.3728	-0.3710	-0.1663	-0.3534	-0.4287	*****	*****	*****	*****	*****
0.350	*****	-0.3685	-0.1761	-0.3388	-0.5206	*****	*****	*****	*****	*****
0.400	-0.3852	-0.3650	-0.1831	-0.3188	-0.6740	*****	*****	*****	*****	*****
0.450	-0.3971	-0.3679	-0.1637	-0.3140	-0.6880	*****	*****	*****	*****	*****
0.500	-0.4238	-0.3551	-0.2186	-0.3283	-0.6850	*****	*****	*****	*****	*****
0.525	*****	-0.3593	-0.2517	-0.3588	-0.7100	*****	*****	*****	*****	*****
0.550	-0.4466	-0.3695	-0.3202	-0.4158	-0.7415	*****	*****	*****	*****	*****
0.575	*****	-0.3993	-0.4234	-0.5144	-0.8256	*****	*****	*****	*****	*****
0.600	-0.4682	-0.5011	-0.6668	-0.6570	-0.9089	*****	*****	*****	*****	*****
0.625	*****	*****	-0.8925	-0.8327	-1.0003	*****	*****	*****	*****	*****
0.650	-0.4649	-1.0698	-1.1223	-1.0238	-0.8470	*****	*****	*****	*****	*****
0.675	*****	-1.3195	-1.3068	-1.2018	-0.6195	*****	*****	*****	*****	*****
0.700	-0.7211	-1.4488	-1.4036	-1.0524	-0.5089	*****	*****	*****	*****	*****
0.725	*****	-1.4530	*****	-0.8981	-0.4752	*****	*****	*****	*****	*****
0.750	-1.1159	-1.3555	*****	-0.8715	-0.4673	*****	*****	*****	*****	*****
0.775	*****	-1.3411	-1.2420	-0.8779	-0.4716	*****	*****	*****	*****	*****
0.800	-1.2577	-1.3093	-1.0983	-0.9100	*****	*****	*****	*****	*****	*****
0.825	*****	-1.2656	-1.0174	-0.9245	-0.4785	*****	*****	*****	*****	*****
0.850	-1.3157	-1.2220	-0.9809	-0.9299	-0.4664	*****	*****	*****	*****	*****
0.875	*****	-1.1566	-0.9876	-0.8430	-0.4776	*****	*****	*****	*****	*****
0.900	-1.2972	-1.1005	-0.9531	-0.8003	-0.4672	*****	*****	*****	*****	*****
0.925	*****	-1.0574	-0.8566	-0.8262	-0.4235	*****	*****	*****	*****	*****
0.950	-1.2682	-1.0215	-0.8212	-0.8467	-0.3557	*****	*****	*****	*****	*****
0.975	*****	-1.0054	-0.7995	-0.7456	-0.3041	*****	*****	*****	*****	*****
1.000	-1.3300	-1.1775	-0.8232	-1.0554	-0.3860	*****	*****	*****	*****	*****
-0.200	$C_{p,l}$	$C_{p,l}$	$C_{p,l}$	$C_{p,l}$	$C_{p,l}$	$C_{p,l}$	$C_{p,l}$	$C_{p,l}$	$C_{p,l}$	$C_{p,l}$
-0.400	0.3442	0.3145	0.3155	*****	*****	-0.5767	*****	*****	*****	*****
-0.600	0.3437	0.3230	0.2912	0.1079	0.6585	*****	*****	*****	*****	*****
-0.700	0.3616	0.3294	0.2878	0.1413	-0.6346	*****	*****	*****	*****	*****
-0.800	0.3748	0.3314	0.2951	0.1612	-0.6009	*****	*****	*****	*****	*****
-0.850	0.3807	*****	0.2943	0.1848	-0.5222	*****	*****	*****	*****	*****
-0.900	*****	0.3487	0.2994	0.1938	-0.5086	*****	*****	*****	*****	*****
-0.950	0.2404	0.3354	0.2973	0.2085	-0.4633	*****	*****	*****	*****	*****
-0.975	0.2404	0.2602	0.2475	0.1942	-0.1487	*****	*****	*****	*****	*****
-1.000	0.1116	0.1116	0.1384	0.1144	-0.0461	*****	*****	*****	*****	*****
-1.000	-1.2711	-1.1161	-0.9195	-0.9470	-0.4770	*****	*****	*****	*****	*****

Medium Radius L.E.
 Run No. = 16 , Point No. = 348
 $C_N = 0.694$, $C_m = -0.1019$
 $\alpha = 14.7^\circ$, $M_\infty = 0.849$
 $R_{mac} = 108.7 \times 10^6$

Leading Edge Pressures



x/c_R	starb'd C_p	port C_p
0.10	-0.9933	*****
0.20	-1.3300	-1.2711
0.30	-1.3271	*****
0.40	-1.1775	-1.1161
0.50	-1.0213	*****
0.60	-0.8232	-0.9195
0.70	-0.8280	*****
0.80	-1.0554	-0.9470
0.90	*****	*****
0.95	-0.3860	-0.4770

Surface Pressures

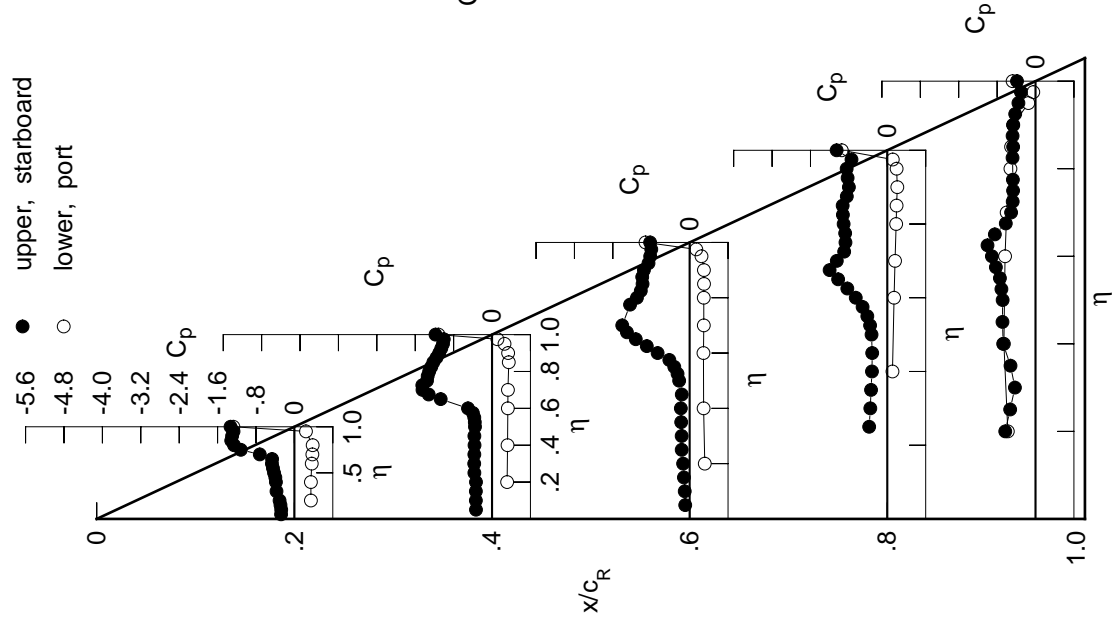

Table E10. Concluded.

η	$x/c_R = .2$		$x/c_R = .4$		$x/c_R = .6$		$x/c_R = .8$		$x/c_R = .95$	
	$C_{p,u}$	$C_{p,u}$	$C_{p,u}$	$C_{p,u}$	$C_{p,u}$	$C_{p,u}$	$C_{p,u}$	$C_{p,u}$	$C_{p,u}$	$C_{p,u}$
0.050	-0.3265	-0.3993	-0.0929	*****	*****	*****	*****	*****	*****	*****
0.100	-0.3227	-0.3955	-0.1065	*****	*****	*****	*****	*****	*****	*****
0.150	-0.3369	-0.3915	-0.1166	*****	*****	*****	*****	*****	*****	*****
0.200	-0.3669	-0.4157	-0.1466	*****	*****	*****	*****	*****	*****	-0.7488
0.250	*****	-0.4126	-0.1584	-0.2107	-0.1762	-0.1762	-0.1762	-0.1762	-0.1762	-0.7560
0.300	-0.3976	-0.4098	-0.1694	-0.1762	-0.1762	-0.1762	-0.1762	-0.1762	-0.1762	-0.7592
0.350	*****	-0.4097	-0.1851	-0.1697	-0.1697	-0.1697	-0.1697	-0.1697	-0.1697	-0.7581
0.400	-0.4101	-0.4105	-0.2051	-0.1406	-0.1406	-0.1406	-0.1406	-0.1406	-0.1406	-0.7697
0.450	-0.4310	-0.4177	-0.2214	-0.1551	-0.1551	-0.1551	-0.1551	-0.1551	-0.1551	-0.7778
0.500	-0.4410	-0.4434	-0.3755	-0.2221	-0.2221	-0.2221	-0.2221	-0.2221	-0.2221	-0.7644
0.525	*****	-0.5108	-0.4902	-0.2924	-0.2924	-0.2924	-0.2924	-0.2924	-0.2924	-0.7734
0.550	-0.4094	-0.6292	-0.6492	-0.3998	-0.3998	-0.3998	-0.3998	-0.3998	-0.3998	-0.7362
0.575	*****	-0.8247	-0.8214	-0.5433	-0.5433	-0.5433	-0.5433	-0.5433	-0.5433	-0.7366
0.600	-0.4107	-1.0574	-1.0505	-0.7175	-0.7175	-0.7175	-0.7175	-0.7175	-0.7175	-0.7127
0.625	*****	*****	-1.2154	-0.8832	-0.8832	-0.8832	-0.8832	-0.8832	-0.8832	-0.7005
0.650	-1.2414	-1.4492	-1.3621	-0.8206	-0.8206	-0.8206	-0.8206	-0.8206	-0.8206	-0.7002
0.675	*****	-1.5013	-1.4759	-0.5762	-0.5762	-0.5762	-0.5762	-0.5762	-0.5762	-0.6754
0.700	-1.4524	-1.5442	-1.3122	-0.5290	-0.5290	-0.5290	-0.5290	-0.5290	-0.5290	-0.6583
0.725	*****	-1.5191	*****	-0.5180	-0.5180	-0.5180	-0.5180	-0.5180	-0.5180	-0.6466
0.750	-1.4206	-1.4636	*****	-0.5162	-0.5162	-0.5162	-0.5162	-0.5162	-0.5162	-0.6205
0.775	*****	-1.3870	-1.1935	-0.5321	-0.5321	-0.5321	-0.5321	-0.5321	-0.5321	-0.5973
0.800	-1.4085	-1.3066	-1.1907	-0.5617	-0.5617	-0.5617	-0.5617	-0.5617	-0.5617	*****
0.825	*****	-1.2172	-1.1748	-0.5528	-0.5528	-0.5528	-0.5528	-0.5528	-0.5528	-0.5607
0.850	-1.3621	-1.1642	-1.1259	-0.5651	-0.5651	-0.5651	-0.5651	-0.5651	-0.5651	-0.5229
0.875	*****	-1.1384	-1.0504	-0.5645	-0.5645	-0.5645	-0.5645	-0.5645	-0.5645	-0.5027
0.900	-1.2928	-1.1223	-0.9491	-0.5845	-0.5845	-0.5845	-0.5845	-0.5845	-0.5845	-0.4835
0.925	*****	-1.0752	-0.8906	-0.5967	-0.5967	-0.5967	-0.5967	-0.5967	-0.5967	-0.4734
0.950	-1.2409	-1.0420	-0.8673	-0.5976	-0.5976	-0.5976	-0.5976	-0.5976	-0.5976	-0.4289
0.975	*****	-1.0239	-0.8484	-0.5371	-0.5371	-0.5371	-0.5371	-0.5371	-0.5371	-0.4061
1.000	-1.4191	-1.1300	-0.8325	-0.6532	-0.6532	-0.6532	-0.6532	-0.6532	-0.6532	-0.5018
-0.200	0.4026	0.3609	0.3492	*****	*****	*****	*****	*****	*****	-0.5848
-0.400	0.4022	0.3694	0.3241	0.1309	0.1309	0.1309	0.1309	0.1309	0.1309	-0.6579
-0.600	0.4182	0.3744	0.3212	0.1673	0.1673	0.1673	0.1673	0.1673	0.1673	-0.6295
-0.700	0.4267	0.3761	0.3292	0.1863	0.1863	0.1863	0.1863	0.1863	0.1863	-0.5925
-0.800	0.4220	*****	0.3259	0.2119	0.2119	0.2119	0.2119	0.2119	0.2119	-0.5137
-0.850	*****	0.3812	0.3270	0.2205	0.2205	0.2205	0.2205	0.2205	0.2205	-0.4985
-0.900	*****	0.3547	0.3156	0.2326	0.2326	0.2326	0.2326	0.2326	0.2326	-0.4555
-0.950	0.2314	0.2553	0.2418	0.2065	0.2065	0.2065	0.2065	0.2065	0.2065	-0.1566
-0.975	*****	0.0797	0.1069	0.1145	0.1145	0.1145	0.1145	0.1145	0.1145	-0.0737
-1.000	-1.3424	-1.0789	-0.8803	-0.7450	-0.7450	-0.7450	-0.7450	-0.7450	-0.7450	-0.5526

Medium Radius L.E.
 Run No. = 16 , Point No. = 349
 $C_N = 0.733$, $C_m = -0.0865$
 $\alpha = 16.7^\circ$, $M_\infty = 0.850$
 $R_{mac} = 108.6 \times 10^6$

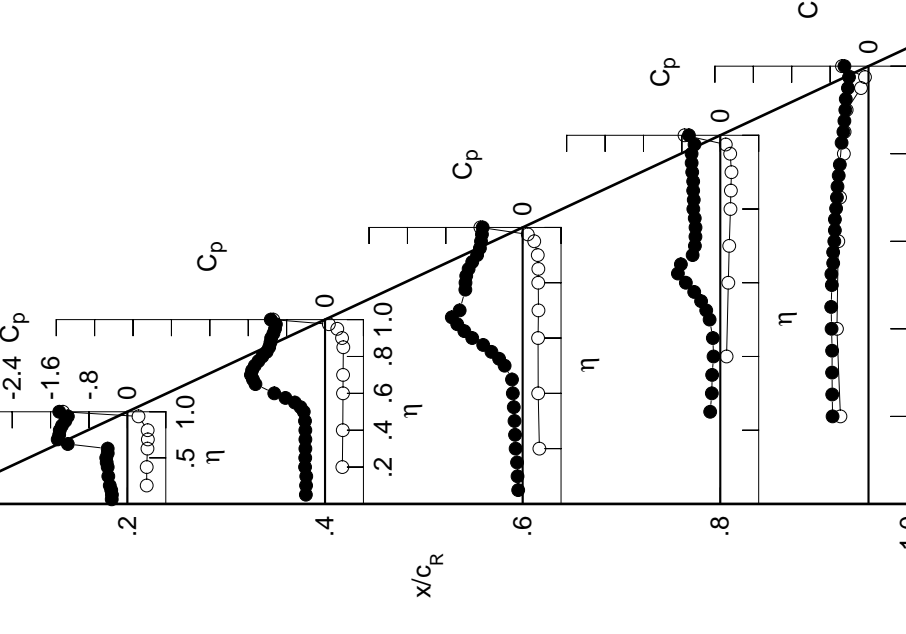
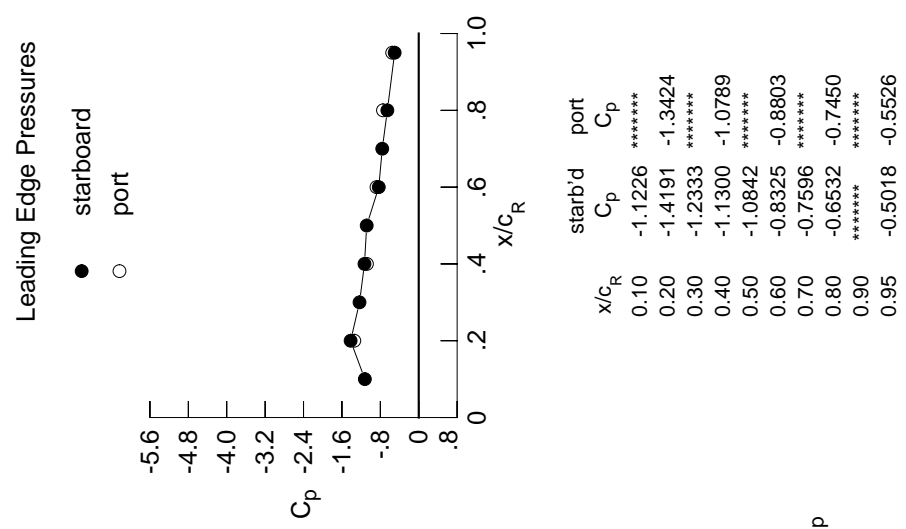
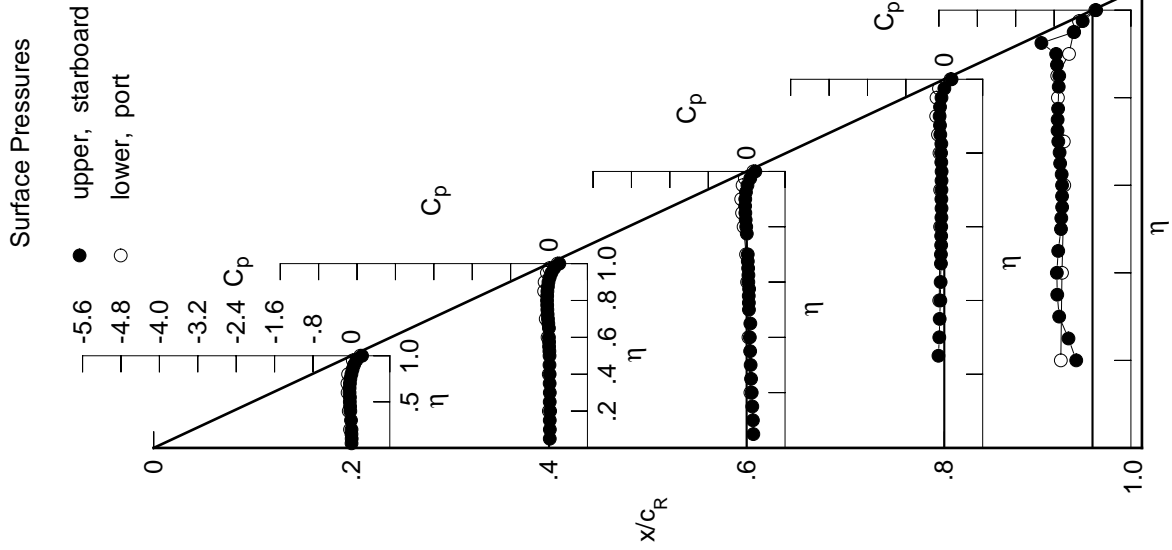

Table E11. Tabulations and Plots of Surface Pressure Coefficients.

η	$x/c_R = .2$		$x/c_R = .4$		$x/c_R = .6$		$x/c_R = .8$		$x/c_R = .95$	
	$C_{p,u}$	$C_{p,l}$	$C_{p,u}$	$C_{p,l}$	$C_{p,u}$	$C_{p,l}$	$C_{p,u}$	$C_{p,l}$	$C_{p,u}$	$C_{p,l}$
0.050	0.0033	0.0155	0.1395	0.1395	0.1395	0.1395	0.1395	0.1395	0.1395	0.1395
0.100	0.0059	0.0167	0.1304	0.1304	0.1304	0.1304	0.1304	0.1304	0.1304	0.1304
0.150	0.0071	0.0156	0.1173	0.1173	0.1173	0.1173	0.1173	0.1173	0.1173	0.1173
0.200	0.0020	0.0222	0.1058	0.1058	0.1058	0.1058	0.1058	0.1058	0.1058	0.1058
0.250	0.0000	0.0144	0.0919	0.0919	0.0919	0.0919	0.0919	0.0919	0.0919	0.0919
0.300	-0.0080	0.0162	0.0829	0.1044	0.1044	0.1044	0.1044	0.1044	0.1044	0.1044
0.350	0.0000	0.0126	0.0728	0.0959	0.0959	0.0959	0.0959	0.0959	0.0959	0.0959
0.400	-0.0224	0.0129	0.0664	0.0824	0.0824	0.0824	0.0824	0.0824	0.0824	0.0824
0.450	-0.0269	0.0100	0.0767	0.0761	0.0761	0.0761	0.0761	0.0761	0.0761	0.0761
0.500	-0.0327	0.0101	0.0483	0.0698	0.0698	0.0698	0.0698	0.0698	0.0698	0.0698
0.525	0.0000	0.0072	0.0467	0.0696	0.0696	0.0696	0.0696	0.0696	0.0696	0.0696
0.550	-0.0307	0.0007	0.0436	0.0647	0.0647	0.0647	0.0647	0.0647	0.0647	0.0647
0.575	0.0000	0.0009	0.0509	0.0648	0.0648	0.0648	0.0648	0.0648	0.0648	0.0648
0.600	-0.0386	0.0024	0.0356	0.0643	0.0643	0.0643	0.0643	0.0643	0.0643	0.0643
0.625	0.0000	0.0000	0.0367	0.0600	0.0600	0.0600	0.0600	0.0600	0.0600	0.0600
0.650	-0.0377	0.0024	0.0315	0.0573	0.0573	0.0573	0.0573	0.0573	0.0573	0.0573
0.675	0.0000	-0.0153	0.0241	0.0610	0.0610	0.0610	0.0610	0.0610	0.0610	0.0610
0.700	-0.0308	0.0024	0.0236	0.0589	0.0589	0.0589	0.0589	0.0589	0.0589	0.0589
0.725	0.0000	-0.0293	0.0000	0.0577	0.0577	0.0577	0.0577	0.0577	0.0577	0.0577
0.750	-0.0216	0.0355	0.0000	0.0563	0.0563	0.0563	0.0563	0.0563	0.0563	0.0563
0.775	0.0000	-0.0381	0.0030	0.0624	0.0624	0.0624	0.0624	0.0624	0.0624	0.0624
0.800	-0.0004	-0.0414	0.0089	0.0671	0.0671	0.0671	0.0671	0.0671	0.0671	0.0671
0.825	0.0000	-0.0386	0.0200	0.0616	0.0616	0.0616	0.0616	0.0616	0.0616	0.0616
0.850	0.0232	-0.0344	0.0275	0.0832	0.0832	0.0832	0.0832	0.0832	0.0832	0.0832
0.875	0.0000	-0.0236	0.0322	0.0898	0.0898	0.0898	0.0898	0.0898	0.0898	0.0898
0.900	0.0544	-0.0121	0.0287	0.0980	0.0980	0.0980	0.0980	0.0980	0.0980	0.0980
0.925	0.0000	0.0134	-0.0146	0.0889	0.0889	0.0889	0.0889	0.0889	0.0889	0.0889
0.950	0.1035	0.0505	0.0167	0.0588	0.0588	0.0588	0.0588	0.0588	0.0588	0.0588
0.975	0.0000	0.1068	0.0754	0.0018	0.02049	0.02049	0.02049	0.02049	0.02049	0.02049
1.000	0.2217	0.2145	0.1806	0.1515	0.1515	0.1515	0.1515	0.1515	0.1515	0.1515
-0.200	-0.0289	-0.0038	0.0787	0.0000	0.0000	0.0000	0.0000	0.0000	0.0000	0.0000
-0.400	-0.0550	-0.0056	0.0385	-0.1053	-0.1053	-0.1053	-0.1053	-0.1053	-0.1053	-0.1053
-0.600	-0.0782	-0.0301	0.0093	-0.0871	-0.0871	-0.0871	-0.0871	-0.0871	-0.0871	-0.0871
-0.700	-0.0820	-0.0690	-0.0121	-0.0861	-0.0861	-0.0861	-0.0861	-0.0861	-0.0861	-0.0861
-0.800	-0.0681	0.0000	-0.0632	-0.1002	-0.1002	-0.1002	-0.1002	-0.1002	-0.1002	-0.1002
-0.850	0.0000	-0.1028	-0.0955	-0.1315	-0.1315	-0.1315	-0.1315	-0.1315	-0.1315	-0.1315
-0.900	0.0000	-0.0917	-0.1136	-0.1691	-0.1691	-0.1691	-0.1691	-0.1691	-0.1691	-0.1691
-0.950	0.0294	-0.0441	-0.0842	-0.1618	-0.1618	-0.1618	-0.1618	-0.1618	-0.1618	-0.1618
-0.975	0.0000	0.0058	-0.0378	-0.1103	-0.1103	-0.1103	-0.1103	-0.1103	-0.1103	-0.1103
-1.000	0.1850	0.1767	0.1392	0.1307	0.1307	0.1307	0.1307	0.1307	0.1307	0.1307

Medium Radius L.E.
 Run No. = 17, Point No. = 350
 $C_N = -0.030$, $C_m = 0.0029$
 $\alpha = -0.8^\circ$, $M_\infty = 0.851$
 $R_{mac} = 120.0 \times 10^6$



Leading Edge Pressures

● starboard
 ○ port

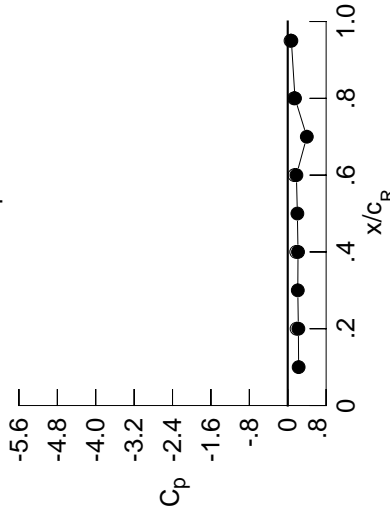

x/c_R	starb'd C_p	port C_p
0.10	0.2271	0.1850
0.20	0.2217	0.1850
0.30	0.2097	0.1767
0.40	0.2145	0.1767
0.50	0.2006	0.1767
0.60	0.1806	0.1392
0.70	0.3979	0.1307
0.80	0.1515	0.1307
0.90	0.0759	0.0585
0.95	0.0759	0.0585

Table E11. Continued.

η	x/c_R .2	x/c_R .4	x/c_R .6	x/c_R .8	x/c_R .95
	$C_{p,u}$	$C_{p,u}$	$C_{p,u}$	$C_{p,u}$	$C_{p,u}$
0.050	-0.0039	0.0094	0.1360	*****	*****
0.100	-0.0014	0.0102	0.1264	*****	*****
0.150	-0.0058	0.0102	0.1132	*****	*****
0.200	-0.0049	0.0157	0.1021	*****	-0.3369
0.250	*****	0.0084	0.0877	-0.1254	-0.4985
0.300	-0.0153	0.0095	0.0785	-0.1087	-0.6720
0.350	*****	0.0064	0.0682	-0.1002	-0.7155
0.400	-0.0305	0.0064	0.0615	-0.0865	-0.7105
0.450	-0.0347	0.0027	0.0725	-0.0805	-0.6592
0.500	-0.0414	0.0031	0.0430	-0.0743	-0.5902
0.525	*****	-0.0005	0.0414	-0.0741	-0.5914
0.550	-0.0404	-0.0071	0.0380	-0.0698	-0.5738
0.575	*****	-0.0074	0.0452	-0.0699	-0.5787
0.600	-0.0487	-0.0108	0.0292	-0.0698	-0.5795
0.625	*****	*****	0.0309	-0.0649	-0.5915
0.650	-0.0488	-0.0111	0.0293	-0.0628	-0.6306
0.675	*****	-0.0243	0.0174	-0.0669	-0.6512
0.700	-0.0432	-0.0324	0.0159	-0.0652	-0.6899
0.725	*****	-0.0403	*****	-0.0641	-0.7188
0.750	-0.0344	-0.0472	*****	-0.0634	-0.7260
0.775	*****	-0.0505	-0.0060	-0.0703	-0.7192
0.800	-0.0141	-0.0546	-0.0193	-0.0759	*****
0.825	*****	-0.0535	-0.0318	-0.0704	-0.7042
0.850	0.0091	-0.0498	-0.0410	-0.0941	-0.6951
0.875	*****	-0.0403	-0.0471	-0.1032	-0.7477
0.900	0.0392	-0.0299	-0.0460	-0.1136	-0.7293
0.925	*****	-0.0056	-0.0332	-0.1071	-0.9519
0.950	0.0881	0.0310	-0.0041	-0.0797	-0.3934
0.975	*****	0.0870	0.0543	-0.0215	-0.2218
1.000	0.2267	0.2228	0.2001	0.1657	0.0866
	$C_{p,l}$	$C_{p,l}$	$C_{p,l}$	$C_{p,l}$	$C_{p,l}$
-0.200	-0.0209	0.0027	0.0843	*****	-0.6488
-0.400	-0.0465	0.0019	0.0442	-0.1005	-0.6001
-0.600	-0.0669	-0.0215	0.0162	-0.0809	-0.5810
-0.700	-0.0691	-0.0582	-0.0036	-0.0789	-0.6030
-0.800	-0.0533	*****	-0.0511	-0.0905	-0.7110
-0.850	*****	-0.0850	-0.0803	-0.1197	-0.7440
-0.900	*****	-0.0712	-0.0937	-0.1515	-0.5063
-0.950	0.0487	-0.0202	-0.0582	-0.1369	-0.3786
-0.975	*****	0.0321	-0.0083	-0.0813	-0.2600
-1.000	0.1927	0.1898	0.1568	0.1522	0.0716

Medium Radius L.E.
 Run No. = 17, Point No. = 351
 $C_N = -0.015$, $C_m = 0.0004$
 $\alpha = -0.4^\circ$, $M_\infty = 0.851$
 $R_{mac} = 120.1 \times 10^6$

Leading Edge Pressures

● starboard
 ○ port

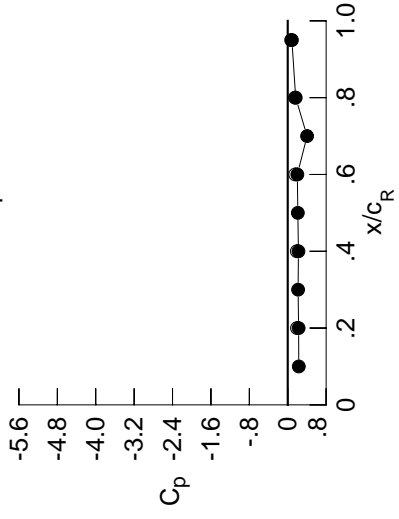

x/c_R	starb'd C_p	port C_p
0.10	0.2303	*****
0.20	0.2267	0.1927
0.30	0.2159	*****
0.40	0.2228	0.1898
0.50	0.2105	*****
0.60	0.2001	0.1568
0.70	0.4034	*****
0.80	0.1657	0.1522
0.90	*****	*****
0.95	0.0866	0.0716

Surface Pressures
 ● upper, starboard
 ○ lower, port

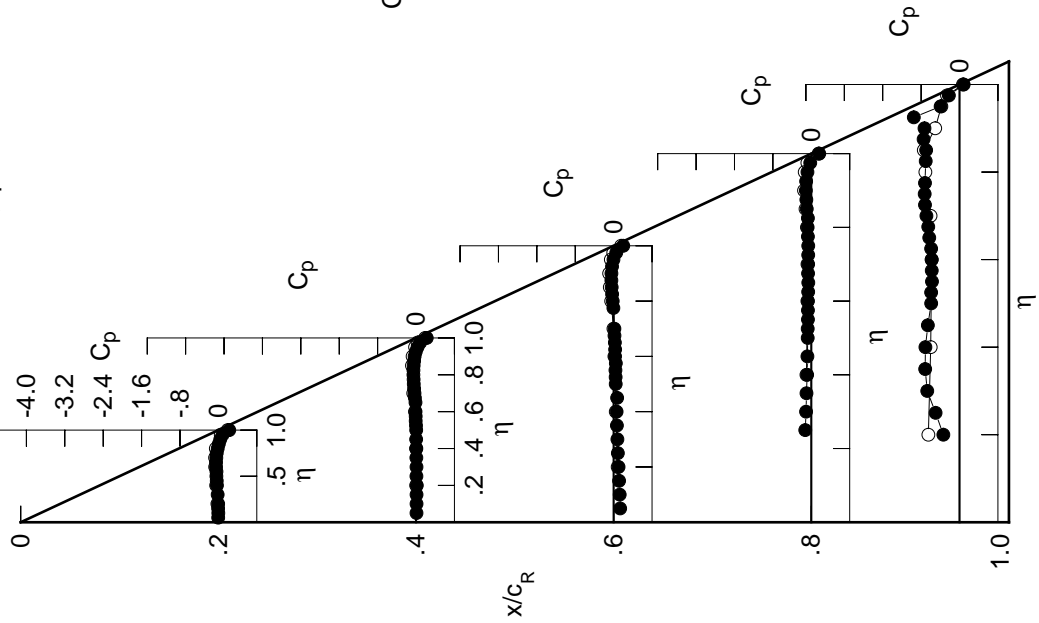

Table E11. Continued.

η	$x/c_R = .2$		$x/c_R = .4$		$x/c_R = .6$		$x/c_R = .8$		$x/c_R = .95$	
	$C_{p,u}$	$C_{p,u}$	$C_{p,u}$	$C_{p,u}$	$C_{p,u}$	$C_{p,u}$	$C_{p,u}$	$C_{p,u}$	$C_{p,u}$	$C_{p,u}$
0.050	-0.0245	-0.0085	0.1235	*****	*****	*****	*****	*****	*****	
0.100	-0.0217	-0.0080	0.1140	*****	*****	*****	*****	*****	*****	
0.150	-0.0262	-0.0085	0.1001	*****	*****	*****	*****	*****	*****	
0.200	-0.0256	-0.0032	0.0887	*****	*****	*****	*****	*****	-0.3190	
0.250	*****	-0.0102	0.0746	-0.1378	-0.4717	*****	*****	*****	*****	
0.300	-0.0363	-0.0098	0.0647	-0.1214	-0.6545	*****	*****	*****	*****	
0.350	*****	-0.0134	0.0541	-0.1130	-0.7104	*****	*****	*****	*****	
0.400	-0.0545	-0.0139	0.0468	-0.0998	-0.7030	*****	*****	*****	*****	
0.450	-0.0609	-0.0182	0.0569	-0.0939	-0.6473	*****	*****	*****	*****	
0.500	-0.0686	-0.0187	0.0270	-0.0887	-0.5666	*****	*****	*****	*****	
0.525	*****	-0.0233	0.0249	-0.0890	-0.5682	*****	*****	*****	*****	
0.550	-0.0699	-0.0309	0.0207	-0.0848	-0.5494	*****	*****	*****	*****	
0.575	*****	-0.0318	0.0271	-0.0856	-0.5538	*****	*****	*****	*****	
0.600	-0.0798	-0.0364	0.0102	-0.0859	-0.5535	*****	*****	*****	*****	
0.625	*****	*****	0.0118	-0.0826	-0.5661	*****	*****	*****	*****	
0.650	-0.0825	-0.0377	0.0045	-0.0809	-0.6075	*****	*****	*****	*****	
0.675	*****	-0.0530	-0.0040	-0.0851	-0.6303	*****	*****	*****	*****	
0.700	-0.0792	-0.0628	-0.0070	-0.0848	-0.6771	*****	*****	*****	*****	
0.725	*****	-0.0733	*****	-0.0848	-0.7185	*****	*****	*****	*****	
0.750	-0.0732	-0.0826	*****	-0.0864	-0.7354	*****	*****	*****	*****	
0.775	*****	-0.0889	-0.0353	-0.0944	-0.7298	*****	*****	*****	*****	
0.800	-0.0559	-0.0968	-0.0523	-0.1029	*****	*****	*****	*****	*****	
0.825	*****	-0.0981	-0.0687	-0.0983	-0.7055	*****	*****	*****	*****	
0.850	-0.0348	-0.0987	-0.0832	-0.1280	-0.7002	*****	*****	*****	*****	
0.875	*****	-0.0927	-0.0949	-0.1429	-0.7512	*****	*****	*****	*****	
0.900	-0.0078	-0.0855	-0.1004	-0.1622	-0.5601	*****	*****	*****	*****	
0.925	*****	-0.0665	-0.0950	-0.1635	-0.7256	*****	*****	*****	*****	
0.950	0.0387	-0.0327	-0.0724	-0.1462	-0.4313	*****	*****	*****	*****	
0.975	*****	0.0177	-0.0204	-0.0974	-0.2797	*****	*****	*****	*****	
1.000	0.2214	0.2143	0.1983	0.1554	0.0812	*****	*****	*****	*****	
η	$C_{p,l}$	$C_{p,l}$	$C_{p,l}$	$C_{p,l}$	$C_{p,l}$	$C_{p,l}$	$C_{p,l}$	$C_{p,l}$	$C_{p,l}$	
-0.200	-0.0002	0.0201	0.0980	*****	*****	-0.6507	*****	*****	*****	
-0.400	-0.0226	0.0215	0.0601	-0.0873	-0.6214	*****	*****	*****	*****	
-0.600	-0.0365	0.0026	0.0358	-0.0648	-0.6216	*****	*****	*****	*****	
-0.700	-0.0335	-0.0269	0.0199	-0.0599	-0.6514	*****	*****	*****	*****	
-0.800	-0.0118	*****	-0.0186	-0.0646	-0.7055	*****	*****	*****	*****	
-0.850	*****	-0.0375	-0.0385	-0.0851	-0.7347	*****	*****	*****	*****	
-0.900	*****	-0.0165	-0.0405	-0.1033	-0.5770	*****	*****	*****	*****	
-0.950	0.0986	0.0415	0.0073	-0.0708	-0.3420	*****	*****	*****	*****	
-0.975	*****	0.0994	0.0644	-0.0065	-0.2039	*****	*****	*****	*****	
-1.000	0.1930	0.1905	0.1595	0.1604	0.0766	*****	*****	*****	*****	

Medium Radius L.E.
 Run No. = 17, Point No. = 352
 $C_N = 0.028$, $C_m = -0.0065$
 $\alpha = 0.7^\circ$, $M_\infty = 0.850$
 $R_{mac} = 120.2 \times 10^6$

Leading Edge Pressures

● starboard
 ○ port

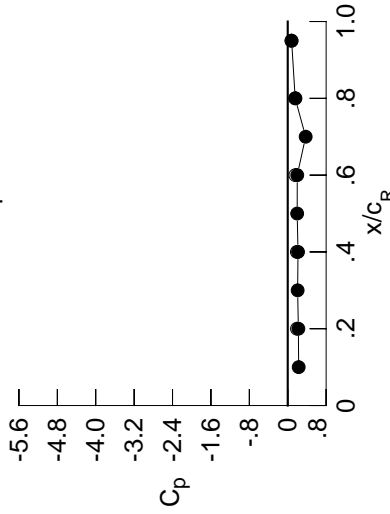

x/c_R	starb'd C_p	port C_p
0.10	0.2277	*****
0.20	0.2214	0.1930
0.30	0.2062	*****
0.40	0.2143	0.1905
0.50	0.1970	*****
0.60	0.1983	0.1595
0.70	0.3736	*****
0.80	0.1554	0.1604
0.90	*****	*****
0.95	0.0812	0.0766

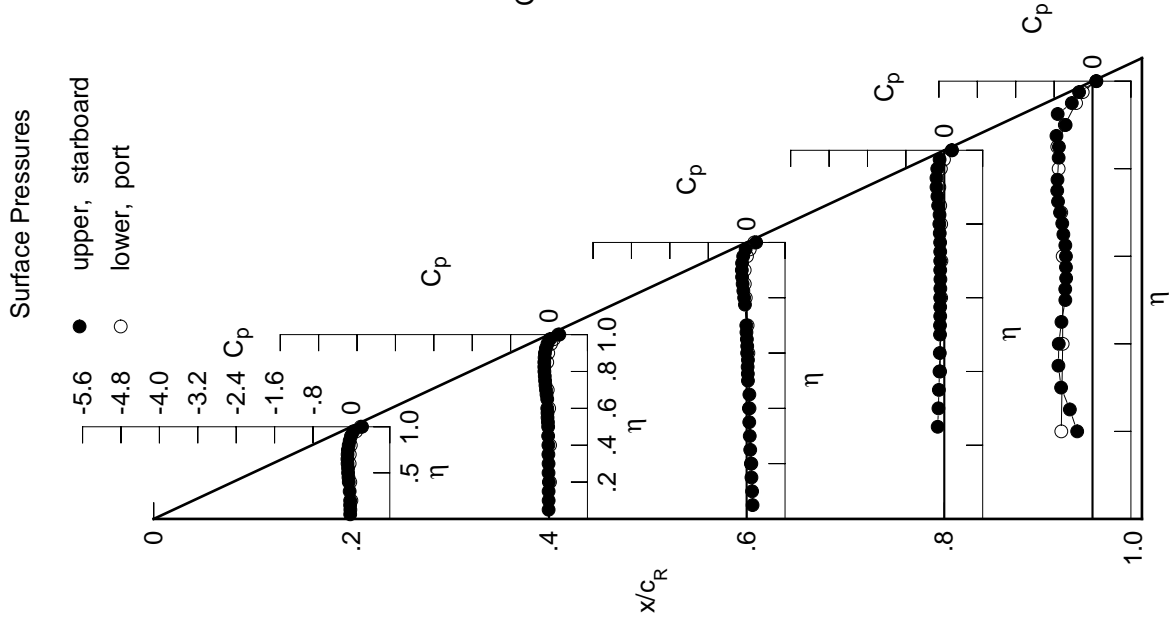

Table E11. Continued.

η	$x/c_R = .2$		$x/c_R = .4$		$x/c_R = .6$		$x/c_R = .8$		$x/c_R = .95$	
	$C_{p,u}$	$C_{p,u}$	$C_{p,u}$	$C_{p,u}$	$C_{p,u}$	$C_{p,u}$	$C_{p,u}$	$C_{p,u}$	$C_{p,u}$	$C_{p,u}$
0.050	-0.0446	-0.0271	0.1101	0.1101	0.0750	0.0750	0.0750	0.0750	0.0750	0.0750
0.100	-0.0418	-0.0265	0.1004	0.1004	0.0871	0.0871	0.0871	0.0871	0.0871	0.0871
0.150	-0.0466	-0.0284	0.0871	0.0871	0.0750	0.0750	0.0750	0.0750	0.0750	0.0750
0.200	-0.0467	-0.0228	0.0750	0.0750	0.0604	0.0604	0.0604	0.0604	0.0604	0.0604
0.250	*****	-0.0296	0.0604	0.0604	0.0506	0.0506	0.0506	0.0506	0.0506	0.0506
0.300	-0.0580	-0.0292	0.0506	0.0506	0.0387	0.0387	0.0387	0.0387	0.0387	0.0387
0.350	*****	-0.0338	0.0387	0.0387	0.0309	0.0309	0.0309	0.0309	0.0309	0.0309
0.400	-0.0786	-0.0348	0.0309	0.0309	0.0394	0.0394	0.0394	0.0394	0.0394	0.0394
0.450	-0.0868	-0.0398	0.0394	0.0394	0.0091	0.0091	0.0091	0.0091	0.0091	0.0091
0.500	-0.0963	-0.0412	0.0091	0.0091	0.0064	0.0064	0.0064	0.0064	0.0064	0.0064
0.525	*****	-0.0460	0.0064	0.0064	0.0020	0.0020	0.0020	0.0020	0.0020	0.0020
0.550	-0.0998	-0.0554	0.0020	0.0020	0.0077	0.0077	0.0077	0.0077	0.0077	0.0077
0.575	*****	-0.0567	0.0077	0.0077	0.0097	0.0097	0.0097	0.0097	0.0097	0.0097
0.600	-0.1123	-0.0629	0.0097	0.0097	0.0097	0.0097	0.0097	0.0097	0.0097	0.0097
0.625	*****	*****	0.0097	0.0097	0.0097	0.0097	0.0097	0.0097	0.0097	0.0097
0.650	-0.1180	-0.0660	0.00173	0.00173	0.00973	0.00973	0.00973	0.00973	0.00973	0.00973
0.675	*****	-0.0826	0.00271	0.00271	0.1033	0.1033	0.1033	0.1033	0.1033	0.1033
0.700	-0.1178	-0.0948	0.0313	0.0313	0.1039	0.1039	0.1039	0.1039	0.1039	0.1039
0.725	*****	-0.1079	0.0313	0.0313	0.1055	0.1055	0.1055	0.1055	0.1055	0.1055
0.750	-0.1150	-0.1201	0.0313	0.0313	0.1082	0.1082	0.1082	0.1082	0.1082	0.1082
0.775	*****	-0.1300	0.0665	0.0665	0.1191	0.1191	0.1191	0.1191	0.1191	0.1191
0.800	-0.1011	-0.1412	0.0869	0.0869	0.1303	0.1303	0.1303	0.1303	0.1303	0.1303
0.825	*****	-0.1470	0.1089	0.1089	0.1283	0.1283	0.1283	0.1283	0.1283	0.1283
0.850	-0.0839	-0.1520	0.1295	0.1295	0.1640	0.1640	0.1640	0.1640	0.1640	0.1640
0.875	*****	-0.1515	0.1482	0.1482	0.1871	0.1871	0.1871	0.1871	0.1871	0.1871
0.900	-0.0619	-0.1488	0.1616	0.1616	0.2158	0.2158	0.2158	0.2158	0.2158	0.2158
0.925	*****	-0.1359	0.1645	0.1645	0.2286	0.2286	0.2286	0.2286	0.2286	0.2286
0.950	-0.0208	-0.1079	0.1527	0.1527	0.2244	0.2244	0.2244	0.2244	0.2244	0.2244
0.975	*****	-0.0701	0.1146	0.1146	0.1917	0.1917	0.1917	0.1917	0.1917	0.1917
1.000	0.1859	0.1525	0.1148	0.1148	0.0656	0.0656	0.0656	0.0656	0.0656	0.0656
	$C_{p,l}$	$C_{p,l}$	$C_{p,l}$	$C_{p,l}$	$C_{p,l}$	$C_{p,l}$	$C_{p,l}$	$C_{p,l}$	$C_{p,l}$	$C_{p,l}$
-0.200	0.0219	0.0384	0.1113	0.1113	0.0680	0.0680	0.0680	0.0680	0.0680	0.0680
-0.400	0.0017	0.0409	0.0756	0.0756	0.0741	0.0741	0.0741	0.0741	0.0741	0.0741
-0.600	-0.0057	0.0277	0.0545	0.0545	0.0494	0.0494	0.0494	0.0494	0.0494	0.0494
-0.700	0.0013	0.0029	0.0432	0.0432	0.0414	0.0414	0.0414	0.0414	0.0414	0.0414
-0.800	0.0277	0.0029	0.0127	0.0127	0.0400	0.0400	0.0400	0.0400	0.0400	0.0400
-0.850	*****	0.0069	0.0012	0.0012	0.0528	0.0528	0.0528	0.0528	0.0528	0.0528
-0.900	*****	0.0339	0.0083	0.0083	0.0591	0.0591	0.0591	0.0591	0.0591	0.0591
-0.950	0.1408	0.0945	0.0642	0.0642	0.0135	0.0135	0.0135	0.0135	0.0135	0.0135
-0.975	*****	0.1518	0.1221	0.1221	0.0528	0.0528	0.0528	0.0528	0.0528	0.0528
-1.000	0.1602	0.1395	0.0856	0.0856	0.0866	0.0866	0.0866	0.0866	0.0866	0.0866

Medium Radius L.E.
 Run No. = 17, Point No. = 353
 $C_N = 0.071$, $C_m = -0.0130$
 $\alpha = 1.8^\circ$, $M_\infty = 0.851$
 $R_{mac} = 120.0 \times 10^6$

Leading Edge Pressures

● starboard
 ○ port

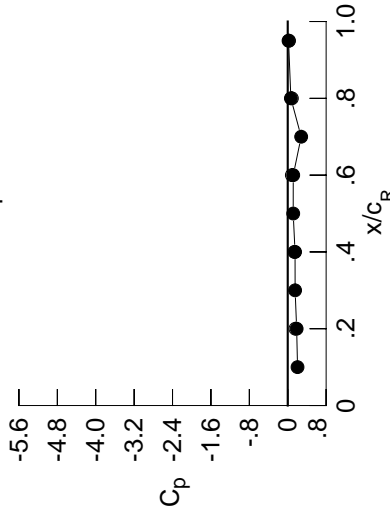

x/c_R	starb'd C_p	port C_p
0.10	0.2043	*****
0.20	0.1859	0.1602
0.30	0.1539	*****
0.40	0.1525	0.1395
0.50	0.1141	*****
0.60	0.1148	0.0856
0.70	0.2802	*****
0.80	0.0656	0.0866
0.90	*****	*****
0.95	0.0171	0.0270

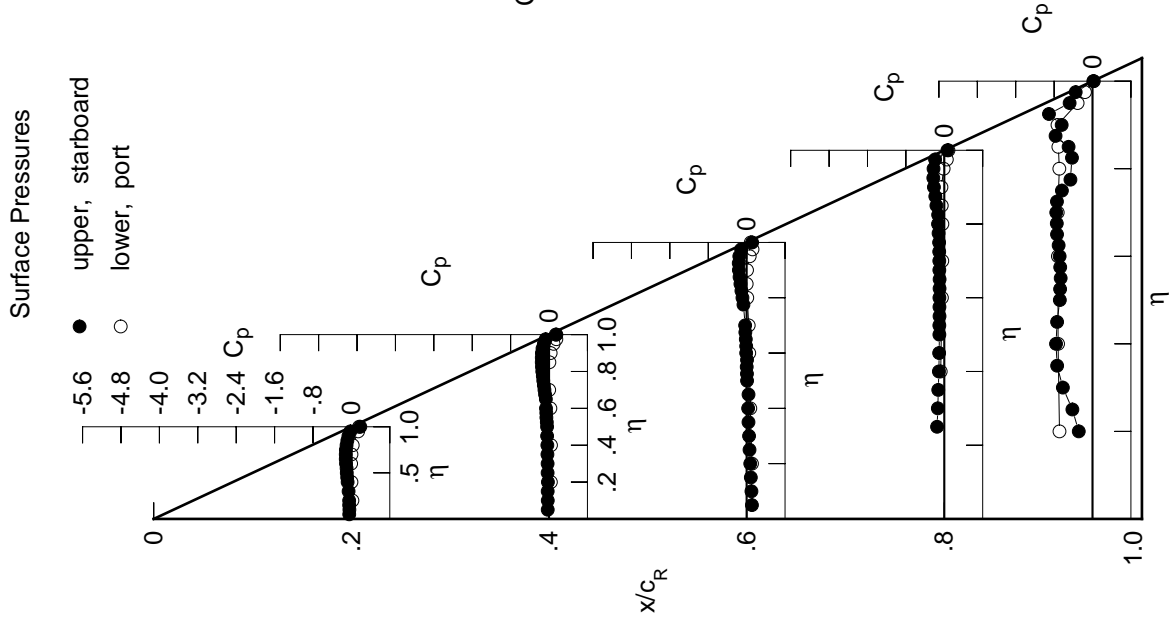
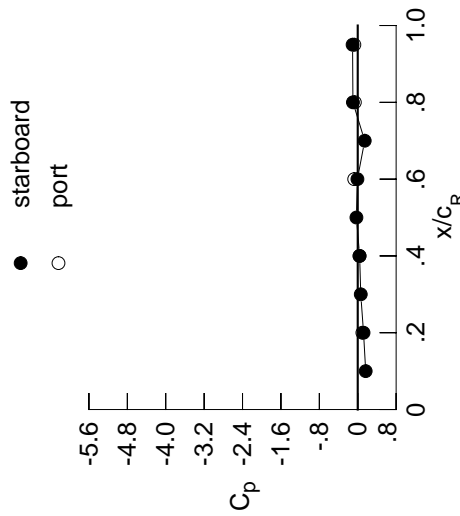

Table E11. Continued.

η	$x/c_R = 0.2$		$x/c_R = 0.4$		$x/c_R = 0.6$		$x/c_R = 0.8$		$x/c_R = 0.95$	
	$C_{p,u}$	$C_{p,l}$	$C_{p,u}$	$C_{p,l}$	$C_{p,u}$	$C_{p,l}$	$C_{p,u}$	$C_{p,l}$	$C_{p,u}$	$C_{p,l}$
0.050	-0.0639	-0.0446	0.0981	*****	*****	*****	*****	*****	*****	*****
0.100	-0.0617	-0.0441	0.0885	*****	*****	*****	*****	*****	*****	*****
0.150	-0.0666	-0.0455	0.0746	*****	*****	*****	*****	*****	*****	*****
0.200	-0.0670	-0.0402	0.0625	*****	*****	*****	*****	*****	*****	*****
0.250	*****	-0.0476	0.0477	-0.1620	-0.3843	*****	*****	*****	*****	*****
0.300	-0.0783	-0.0473	0.0374	-0.1456	-0.5738	*****	*****	*****	*****	*****
0.350	*****	-0.0531	0.0250	-0.1372	-0.7331	*****	*****	*****	*****	*****
0.400	-0.1016	-0.0538	0.0166	-0.1248	-0.7670	*****	*****	*****	*****	*****
0.450	-0.1114	-0.0604	0.0246	-0.1201	-0.7519	*****	*****	*****	*****	*****
0.500	-0.1228	-0.0617	-0.0069	-0.1161	-0.7023	*****	*****	*****	*****	*****
0.525	*****	-0.0691	-0.0104	-0.1169	-0.6963	*****	*****	*****	*****	*****
0.550	-0.1291	-0.0781	-0.0156	-0.1140	-0.6883	*****	*****	*****	*****	*****
0.575	*****	-0.0814	-0.0104	-0.1154	-0.7062	*****	*****	*****	*****	*****
0.600	-0.1437	-0.0875	-0.0289	-0.1177	-0.7242	*****	*****	*****	*****	*****
0.625	*****	*****	-0.0299	-0.1156	-0.7419	*****	*****	*****	*****	*****
0.650	-0.1532	-0.0934	-0.0381	-0.1148	-0.7616	*****	*****	*****	*****	*****
0.675	*****	-0.1115	-0.0494	-0.1219	-0.7481	*****	*****	*****	*****	*****
0.700	-0.1558	-0.1268	-0.0551	-0.1236	-0.7153	*****	*****	*****	*****	*****
0.725	*****	-0.1422	*****	-0.1268	-0.5926	*****	*****	*****	*****	*****
0.750	-0.1567	-0.1579	*****	-0.1312	-0.4244	*****	*****	*****	*****	*****
0.775	*****	-0.1715	-0.0973	-0.1444	-0.2861	*****	*****	*****	*****	*****
0.800	-0.1473	-0.1871	-0.1225	-0.1587	*****	*****	*****	*****	*****	*****
0.825	*****	-0.1971	-0.1495	-0.1584	-0.3034	*****	*****	*****	*****	*****
0.850	-0.1353	-0.2067	-0.1770	-0.1999	-0.3398	*****	*****	*****	*****	*****
0.875	*****	-0.2116	-0.2033	-0.2318	-0.5817	*****	*****	*****	*****	*****
0.900	-0.1188	-0.2160	-0.2264	-0.2708	-0.6403	*****	*****	*****	*****	*****
0.925	*****	-0.2106	-0.2397	-0.2969	-0.8699	*****	*****	*****	*****	*****
0.950	-0.0858	-0.1919	-0.2424	-0.3089	-0.5269	*****	*****	*****	*****	*****
0.975	*****	-0.1688	-0.2235	-0.2986	-0.4304	*****	*****	*****	*****	*****
1.000	0.1210	0.0396	-0.0067	-0.1001	-0.1076	*****	*****	*****	*****	*****
-0.200	$C_{p,l}$	$C_{p,l}$	$C_{p,l}$	$C_{p,l}$	$C_{p,l}$	$C_{p,l}$	$C_{p,l}$	$C_{p,l}$	$C_{p,l}$	$C_{p,l}$
-0.400	0.0435	0.0578	0.1248	*****	-0.6837	*****	*****	*****	*****	*****
-0.600	0.0261	0.0609	0.0910	-0.0607	-0.7355	*****	*****	*****	*****	*****
-0.700	0.0245	0.0516	0.0728	-0.0331	-0.7366	*****	*****	*****	*****	*****
-0.800	0.0351	0.0320	0.0652	-0.0231	-0.7228	*****	*****	*****	*****	*****
-0.850	0.0644	*****	0.0420	-0.0159	-0.6749	*****	*****	*****	*****	*****
-0.900	*****	0.0478	0.0371	-0.0226	-0.6891	*****	*****	*****	*****	*****
-0.950	*****	0.0783	0.0513	-0.0190	-0.7232	*****	*****	*****	*****	*****
-0.975	0.1750	0.1379	0.1096	0.0347	-0.2841	*****	*****	*****	*****	*****
-1.000	*****	0.1876	0.1633	0.0977	-0.1209	*****	*****	*****	*****	*****
	0.0967	0.0354	-0.0733	-0.0601	-0.0702	*****	*****	*****	*****	*****

Medium Radius L.E.
 Run No. = 17, Point No. = 354
 $C_N = 0.113$, $C_m = -0.0191$
 $\alpha = 2.9^\circ$, $M_\infty = 0.850$
 $R_{mac} = 120.0 \times 10^6$

Leading Edge Pressures



x/c_R	starb'd C_p	port C_p
0.10	0.1660	*****
0.20	0.1210	0.0967
0.30	0.0631	*****
0.40	0.0396	0.0354
0.50	-0.0273	*****
0.60	-0.0067	-0.0733
0.70	0.1454	*****
0.80	-0.1001	-0.0601
0.90	*****	*****
0.95	-0.1076	-0.0702

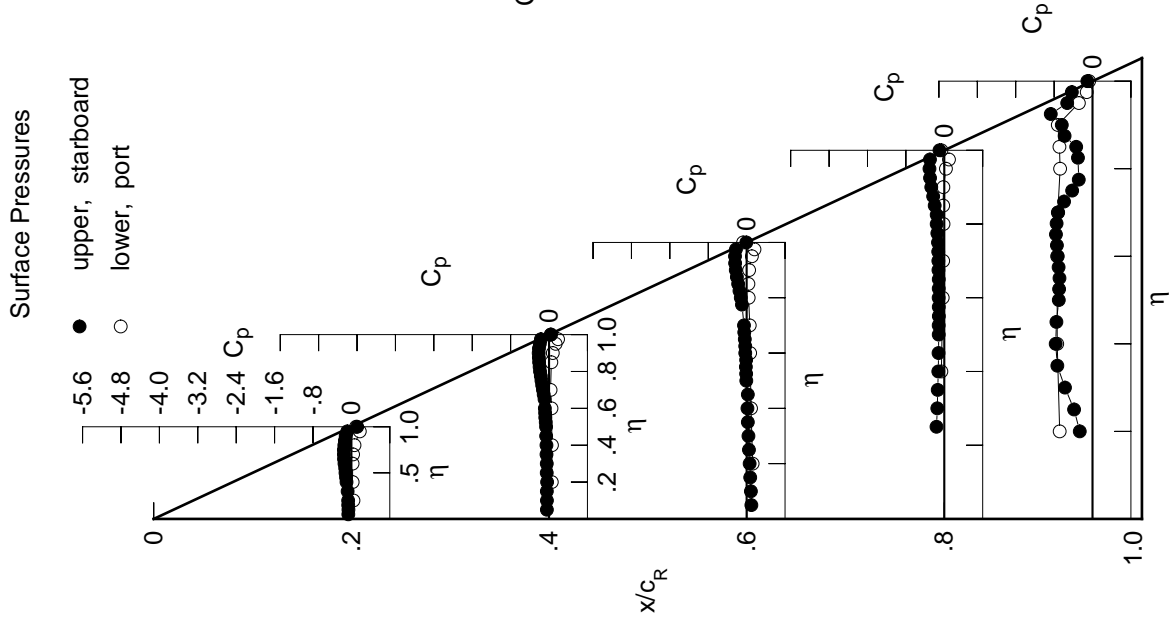
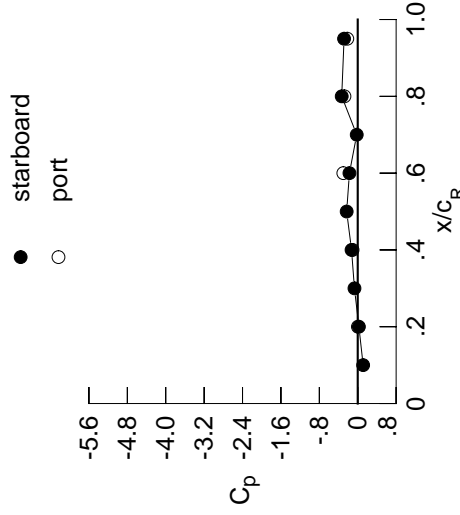

Table E11. Continued.

η	x/c_R .2	x/c_R .4	x/c_R .6	x/c_R .8	x/c_R .95
	$C_{p,u}$	$C_{p,u}$	$C_{p,u}$	$C_{p,u}$	$C_{p,u}$
0.050	-0.0848	-0.0618	0.0869	*****	*****
0.100	-0.0824	-0.0623	0.0770	*****	*****
0.150	-0.0867	-0.0632	0.0633	*****	*****
0.200	-0.0878	-0.0585	0.0511	*****	-0.2989
0.250	*****	-0.0658	0.0354	-0.1744	-0.4045
0.300	-0.0990	-0.0666	0.0247	-0.1576	-0.5768
0.350	*****	-0.0728	0.0115	-0.1501	-0.7260
0.400	-0.1251	-0.0741	0.0024	-0.1376	-0.7623
0.450	-0.1367	-0.0817	0.0094	-0.1332	-0.7451
0.500	-0.1501	-0.0848	-0.0229	-0.1301	-0.6955
0.525	*****	-0.0919	-0.0267	-0.1312	-0.6938
0.550	-0.1588	-0.1027	-0.0329	-0.1294	-0.6908
0.575	*****	-0.1066	-0.0283	-0.1312	-0.7128
0.600	-0.1762	-0.1144	-0.0482	-0.1338	-0.7318
0.625	*****	*****	-0.0497	-0.1327	-0.7435
0.650	-0.1890	-0.1213	-0.0594	-0.1331	-0.7532
0.675	*****	-0.1418	-0.0712	-0.1414	-0.7051
0.700	-0.1952	-0.1589	-0.0790	-0.1445	-0.5925
0.725	*****	-0.1785	*****	-0.1492	-0.4560
0.750	-0.2004	-0.1964	*****	-0.1553	-0.3328
0.775	*****	-0.2144	-0.1292	-0.1706	-0.2236
0.800	-0.1958	-0.2344	-0.1592	-0.1885	*****
0.825	*****	-0.2503	-0.1920	-0.1911	-0.2621
0.850	-0.1890	-0.2653	-0.2267	-0.2395	-0.2812
0.875	*****	-0.2770	-0.2618	-0.2795	-0.4427
0.900	-0.1798	-0.2891	-0.2957	-0.3313	-0.6412
0.925	*****	-0.2928	-0.3219	-0.3712	-0.8344
0.950	-0.1582	-0.2854	-0.3406	-0.4032	-0.5822
0.975	*****	-0.2840	-0.3478	-0.4226	-0.5254
1.000	0.0242	-0.1289	-0.1731	-0.3336	-0.2846
	$C_{p,l}$	$C_{p,l}$	$C_{p,l}$	$C_{p,l}$	$C_{p,l}$
-0.200	0.0655	0.0763	0.1396	*****	-0.6808
-0.400	0.0499	0.0811	0.1064	-0.0476	-0.7425
-0.600	0.0529	0.0748	0.0912	-0.0180	-0.7357
-0.700	0.0671	0.0596	0.0864	-0.0058	-0.7137
-0.800	0.0974	*****	0.0683	0.0057	-0.6589
-0.850	*****	0.0849	0.0698	0.0035	-0.6686
-0.900	*****	0.1169	0.0884	0.0150	-0.6869
-0.950	0.2021	0.1713	0.1464	0.0724	-0.2606
-0.975	*****	0.2104	0.1894	0.1281	-0.0936
-1.000	0.0037	-0.1082	-0.3003	-0.2766	-0.2173

Medium Radius L.E.
 Run No. = 17, Point No. = 355
 $C_N = 0.155$, $C_m = -0.0254$
 $\alpha = 3.9^\circ$, $M_\infty = 0.850$
 $R_{mac} = 120.0 \times 10^6$

Leading Edge Pressures



x/c_R	starb'd C_p	port C_p
0.10	0.1130	*****
0.20	0.0242	0.0037
0.30	-0.0684	*****
0.40	-0.1289	-0.1082
0.50	-0.2306	*****
0.60	-0.1731	-0.3003
0.70	-0.0208	*****
0.80	-0.3336	-0.2766
0.90	*****	*****
0.95	-0.2846	-0.2173

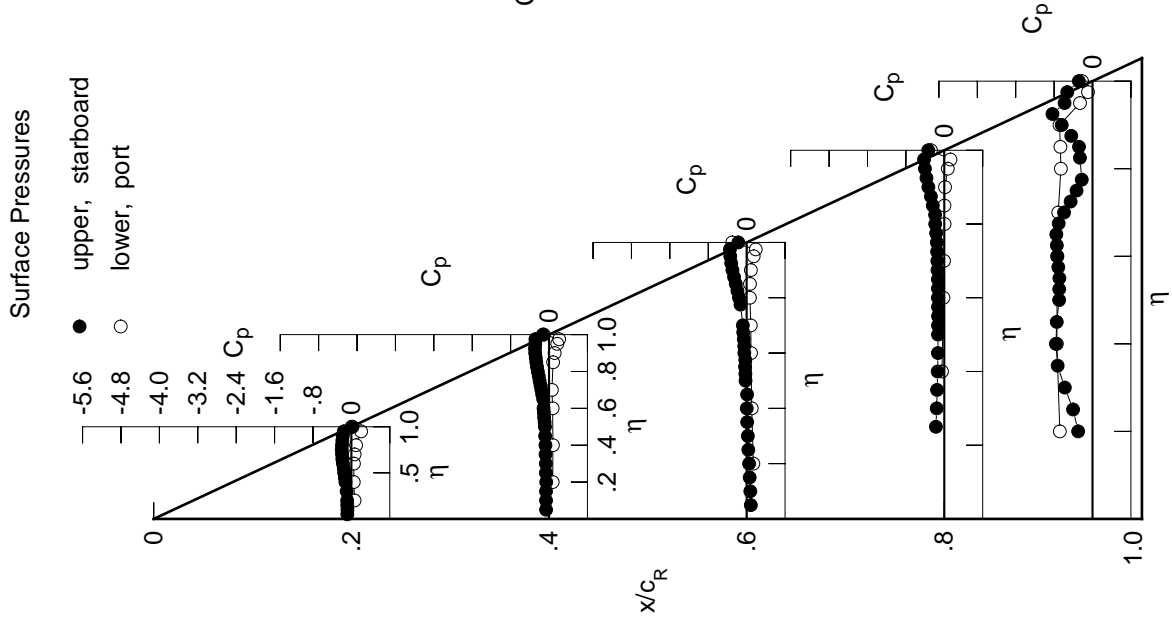
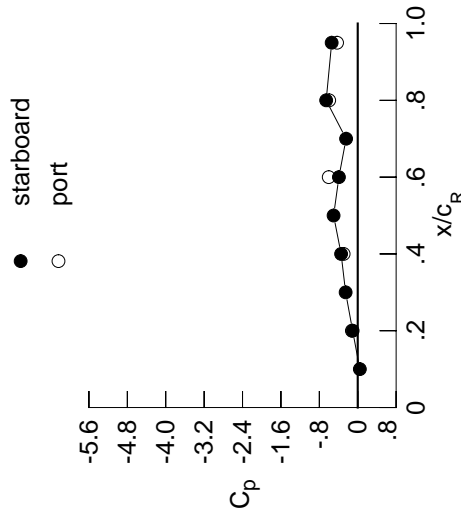

Table E11. Continued.

η	$x/c_R = .2$		$x/c_R = .4$		$x/c_R = .6$		$x/c_R = .8$		$x/c_R = .95$	
	$C_{p,u}$	$C_{p,u}$	$C_{p,u}$	$C_{p,u}$	$C_{p,u}$	$C_{p,u}$	$C_{p,u}$	$C_{p,u}$	$C_{p,u}$	$C_{p,u}$
0.050	-0.1022	-0.0781	0.0765	*****	*****	*****	*****	*****	*****	*****
0.100	-0.1005	-0.0779	0.0665	*****	*****	*****	*****	*****	*****	*****
0.150	-0.1051	-0.0805	0.0528	*****	*****	*****	*****	*****	*****	*****
0.200	-0.1070	-0.0752	0.0401	*****	*****	*****	*****	*****	*****	-0.3017
0.250	*****	-0.0837	0.0241	-0.1854	-0.3847	*****	*****	*****	*****	*****
0.300	-0.1190	-0.0845	0.0124	-0.1688	-0.5331	*****	*****	*****	*****	*****
0.350	*****	-0.0916	-0.0008	-0.1607	-0.6906	*****	*****	*****	*****	*****
0.400	-0.1476	-0.0935	-0.0114	-0.1492	-0.7518	*****	*****	*****	*****	*****
0.450	-0.1607	-0.1022	-0.0039	-0.1455	-0.7429	*****	*****	*****	*****	*****
0.500	-0.1767	-0.1060	-0.0384	-0.1427	-0.7003	*****	*****	*****	*****	*****
0.525	*****	-0.1148	-0.0427	-0.1453	-0.6992	*****	*****	*****	*****	*****
0.550	-0.1879	-0.1261	-0.0502	-0.1431	-0.6955	*****	*****	*****	*****	*****
0.575	*****	-0.1309	-0.0465	-0.1463	-0.7162	*****	*****	*****	*****	*****
0.600	-0.2084	-0.1401	-0.0667	-0.1500	-0.7288	*****	*****	*****	*****	*****
0.625	*****	*****	-0.0693	-0.1489	-0.7260	*****	*****	*****	*****	*****
0.650	-0.2254	-0.1503	-0.0805	-0.1509	-0.7040	*****	*****	*****	*****	*****
0.675	*****	-0.1731	-0.0940	-0.1603	-0.5999	*****	*****	*****	*****	*****
0.700	-0.2363	-0.1923	-0.1035	-0.1643	-0.4794	*****	*****	*****	*****	*****
0.725	*****	-0.2149	*****	-0.1711	-0.3848	*****	*****	*****	*****	*****
0.750	-0.2464	-0.2368	*****	-0.1789	-0.2833	*****	*****	*****	*****	*****
0.775	*****	-0.2597	-0.1629	-0.1975	-0.1973	*****	*****	*****	*****	*****
0.800	-0.2476	-0.2850	-0.1964	-0.2183	*****	*****	*****	*****	*****	*****
0.825	*****	-0.3063	-0.2360	-0.2239	-0.2349	*****	*****	*****	*****	*****
0.850	-0.2475	-0.3280	-0.2782	-0.2788	-0.2528	*****	*****	*****	*****	*****
0.875	*****	-0.3473	-0.3240	-0.3290	-0.3826	*****	*****	*****	*****	*****
0.900	-0.2480	-0.3670	-0.3706	-0.3937	-0.6551	*****	*****	*****	*****	*****
0.925	*****	-0.3839	-0.4103	-0.4500	-0.8162	*****	*****	*****	*****	*****
0.950	-0.2411	-0.3929	-0.4550	-0.5034	-0.6449	*****	*****	*****	*****	*****
0.975	*****	-0.4180	-0.5071	-0.5622	-0.6313	*****	*****	*****	*****	*****
1.000	-0.1061	-0.3461	-0.3921	-0.6573	-0.5428	*****	*****	*****	*****	*****
	$C_{p,l}$	$C_{p,l}$	$C_{p,l}$	$C_{p,l}$	$C_{p,l}$	$C_{p,l}$	$C_{p,l}$	$C_{p,l}$	$C_{p,l}$	$C_{p,l}$
-0.200	0.0897	0.0980	0.1560	*****	-0.6712	*****	*****	*****	*****	*****
-0.400	0.0765	0.1040	0.1241	-0.0322	-0.7325	*****	*****	*****	*****	*****
-0.600	0.0842	0.1006	0.1125	-0.0001	-0.7258	*****	*****	*****	*****	*****
-0.700	0.1003	0.0878	0.1087	0.0142	-0.7004	*****	*****	*****	*****	*****
-0.800	0.1324	*****	0.0960	0.0290	-0.6414	*****	*****	*****	*****	*****
-0.850	*****	0.1202	0.1006	0.0305	-0.6467	*****	*****	*****	*****	*****
-0.900	*****	0.1514	0.1227	0.0479	-0.6530	*****	*****	*****	*****	*****
-0.950	0.2250	0.1990	0.1757	0.1058	-0.2411	*****	*****	*****	*****	*****
-0.975	*****	0.2205	0.2053	0.1491	-0.0743	*****	*****	*****	*****	*****
-1.000	-0.1213	-0.2932	-0.6036	-0.5946	-0.4304	*****	*****	*****	*****	*****

Medium Radius L.E.
 Run No. = 17, Point No. = 356
 $C_N = 0.200$, $C_m = -0.0331$
 $\alpha = 5.0^\circ$, $M_\infty = 0.850$
 $R_{mac} = 120.1 \times 10^6$

Leading Edge Pressures



x/c_R	starb'd C_p	port C_p
0.10	0.0437	*****
0.20	-0.1061	-0.1213
0.30	-0.2524	*****
0.40	-0.3461	-0.2932
0.50	-0.5028	*****
0.60	-0.3921	-0.6036
0.70	-0.2428	*****
0.80	-0.6573	-0.5946
0.90	*****	*****
0.95	-0.5428	-0.4304

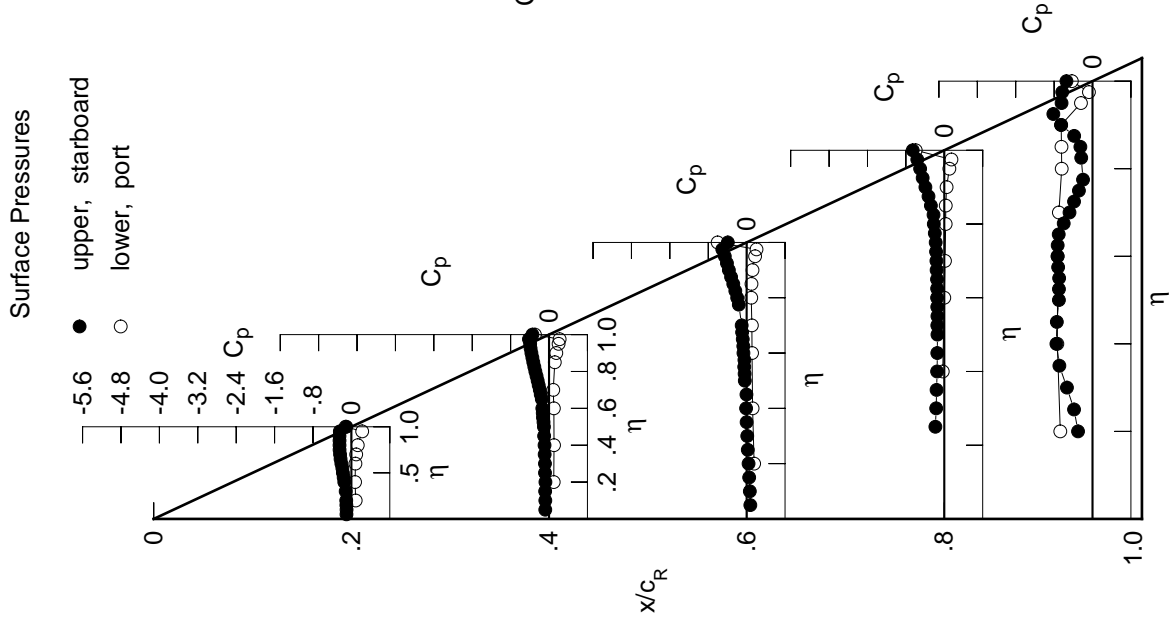
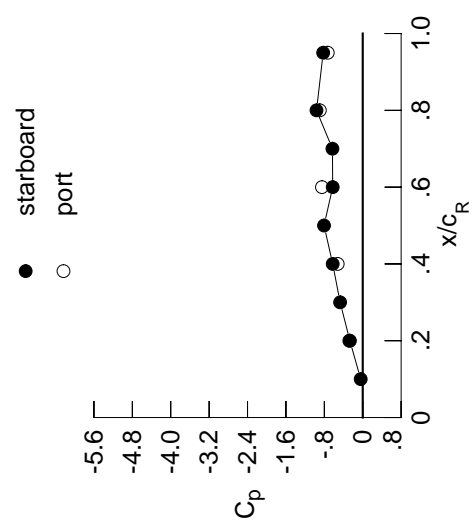

Table E11. Continued.

η	$x/c_R = .2$		$x/c_R = .4$		$x/c_R = .6$		$x/c_R = .8$		$x/c_R = .95$	
	$C_{p,u}$	$C_{p,u}$	$C_{p,u}$	$C_{p,u}$	$C_{p,u}$	$C_{p,u}$	$C_{p,u}$	$C_{p,u}$	$C_{p,u}$	$C_{p,u}$
0.050	-0.1227	-0.0974	0.0635	0.0635	0.0635	0.0635	0.0635	0.0635	0.0635	0.0635
0.100	-0.1218	-0.0968	0.0536	0.0536	0.0536	0.0536	0.0536	0.0536	0.0536	0.0536
0.150	-0.1267	-0.0998	0.0399	0.0399	0.0399	0.0399	0.0399	0.0399	0.0399	0.0399
0.200	-0.1289	-0.0951	0.0270	0.0270	0.0270	0.0270	0.0270	0.0270	0.0270	0.0270
0.250	*****	-0.1036	0.0102	0.0102	0.0102	0.0102	0.0102	0.0102	0.0102	0.0102
0.300	-0.1420	-0.1050	-0.0013	-0.1819	-0.1819	-0.4993	-0.4993	-0.4993	-0.4993	-0.4993
0.350	*****	-0.1128	-0.0160	-0.1740	-0.6371	-0.6371	-0.6371	-0.6371	-0.6371	-0.6371
0.400	-0.1728	-0.1156	-0.0271	-0.1629	-0.7154	-0.7154	-0.7154	-0.7154	-0.7154	-0.7154
0.450	-0.1876	-0.1258	-0.0220	-0.1598	-0.7239	-0.7239	-0.7239	-0.7239	-0.7239	-0.7239
0.500	-0.2057	-0.1312	-0.0561	-0.1582	-0.7217	-0.7217	-0.7217	-0.7217	-0.7217	-0.7217
0.525	*****	-0.1403	-0.0615	-0.1606	-0.7342	-0.7342	-0.7342	-0.7342	-0.7342	-0.7342
0.550	-0.2198	-0.1531	-0.0694	-0.1588	-0.7364	-0.7364	-0.7364	-0.7364	-0.7364	-0.7364
0.575	*****	-0.1595	-0.0666	-0.1632	-0.7522	-0.7522	-0.7522	-0.7522	-0.7522	-0.7522
0.600	-0.2435	-0.1692	-0.0886	-0.1674	-0.7568	-0.7568	-0.7568	-0.7568	-0.7568	-0.7568
0.625	*****	*****	-0.0920	-0.1678	-0.7351	-0.7351	-0.7351	-0.7351	-0.7351	-0.7351
0.650	-0.2642	-0.1814	-0.1044	-0.1712	-0.6677	-0.6677	-0.6677	-0.6677	-0.6677	-0.6677
0.675	*****	-0.2061	-0.1198	-0.1820	-0.5409	-0.5409	-0.5409	-0.5409	-0.5409	-0.5409
0.700	-0.2804	-0.2284	-0.1310	-0.1887	-0.4495	-0.4495	-0.4495	-0.4495	-0.4495	-0.4495
0.725	*****	-0.2542	*****	-0.1988	-0.3733	-0.3733	-0.3733	-0.3733	-0.3733	-0.3733
0.750	-0.2957	-0.2806	*****	-0.2109	-0.2786	-0.2786	-0.2786	-0.2786	-0.2786	-0.2786
0.775	*****	-0.3078	-0.2005	-0.2332	-0.1995	-0.1995	-0.1995	-0.1995	-0.1995	-0.1995
0.800	-0.3038	-0.3389	-0.2382	-0.2556	*****	*****	*****	*****	*****	*****
0.825	*****	-0.3660	-0.2826	-0.2640	-0.2346	-0.2346	-0.2346	-0.2346	-0.2346	-0.2346
0.850	-0.3114	-0.3948	-0.3342	-0.3201	-0.2564	-0.2564	-0.2564	-0.2564	-0.2564	-0.2564
0.875	*****	-0.4243	-0.3908	-0.3769	-0.3449	-0.3449	-0.3449	-0.3449	-0.3449	-0.3449
0.900	-0.3233	-0.4553	-0.4492	-0.4545	-0.6456	-0.6456	-0.6456	-0.6456	-0.6456	-0.6456
0.925	*****	-0.4865	-0.5064	-0.5290	-0.8361	-0.8361	-0.8361	-0.8361	-0.8361	-0.8361
0.950	-0.3341	-0.5132	-0.5667	-0.6160	-0.7104	-0.7104	-0.7104	-0.7104	-0.7104	-0.7104
0.975	*****	-0.5786	-0.6410	-0.7168	-0.7586	-0.7586	-0.7586	-0.7586	-0.7586	-0.7586
1.000	-0.2679	-0.6252	-0.6256	-0.9628	-0.8240	-0.8240	-0.8240	-0.8240	-0.8240	-0.8240
-0.200	$C_{p,l}$	$C_{p,l}$	$C_{p,l}$	$C_{p,l}$	$C_{p,l}$	$C_{p,l}$	$C_{p,l}$	$C_{p,l}$	$C_{p,l}$	$C_{p,l}$
-0.400	0.1133	0.1175	0.1705	0.1705	0.1705	0.1705	0.1705	0.1705	0.1705	0.1705
-0.600	0.1020	0.1241	0.1400	0.1400	0.1400	0.1400	0.1400	0.1400	0.1400	0.1400
-0.700	0.1133	0.1233	0.1304	0.1304	0.1304	0.1304	0.1304	0.1304	0.1304	0.1304
-0.800	0.1314	0.1151	0.1296	0.1296	0.1296	0.1296	0.1296	0.1296	0.1296	0.1296
-0.850	0.1634	*****	0.1216	0.0492	-0.6267	-0.6267	-0.6267	-0.6267	-0.6267	-0.6267
-0.900	*****	0.1522	0.1296	0.0543	-0.6284	-0.6284	-0.6284	-0.6284	-0.6284	-0.6284
-0.950	0.2387	0.1818	0.1523	0.0756	-0.6239	-0.6239	-0.6239	-0.6239	-0.6239	-0.6239
-0.975	*****	0.2194	0.1968	0.1295	-0.2274	-0.2274	-0.2274	-0.2274	-0.2274	-0.2274
-1.000	-0.2791	-0.5219	-0.8494	-0.8936	-0.7286	-0.7286	-0.7286	-0.7286	-0.7286	-0.7286

Medium Radius L.E.
 Run No. = 17, Point No. = 357
 $C_N = 0.245$, $C_m = -0.0402$
 $\alpha = 6.1^\circ$, $M_\infty = 0.850$
 $R_{mac} = 120.1 \times 10^6$

Leading Edge Pressures



x/c_R	starb'd C_p	port C_p
0.10	-0.0422	*****
0.20	-0.2679	-0.2791
0.30	-0.4710	*****
0.40	-0.6252	-0.5219
0.50	-0.8065	*****
0.60	-0.6256	-0.8494
0.70	-0.6312	*****
0.80	-0.9628	-0.8936
0.90	*****	*****
0.95	-0.8240	-0.7286

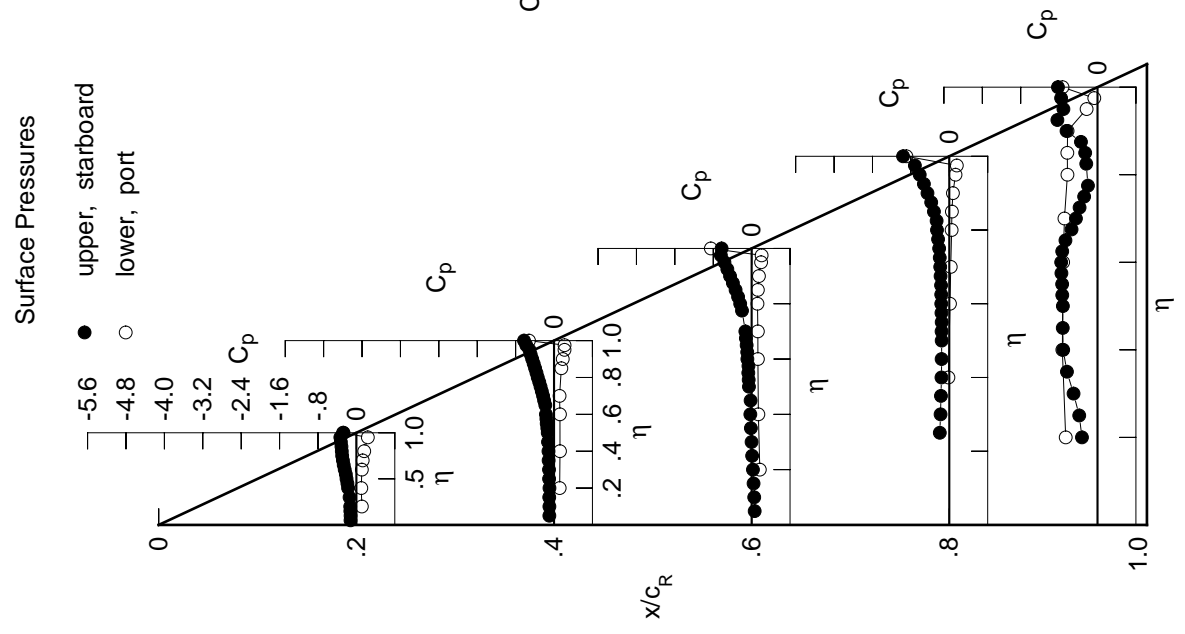

Table E11. Continued.

η	$x/c_R = .2$		$x/c_R = .4$		$x/c_R = .6$		$x/c_R = .8$		$x/c_R = .95$	
	$C_{p,u}$	$C_{p,u}$	$C_{p,u}$	$C_{p,u}$	$C_{p,u}$	$C_{p,u}$	$C_{p,u}$	$C_{p,u}$	$C_{p,u}$	$C_{p,u}$
0.050	-0.1397	-0.1136	0.0520	0.0520	0.0520	0.0520	0.0520	0.0520	0.0520	0.0520
0.100	-0.1401	-0.1141	0.0411	0.0411	0.0411	0.0411	0.0411	0.0411	0.0411	0.0411
0.150	-0.1454	-0.1168	0.0283	0.0283	0.0283	0.0283	0.0283	0.0283	0.0283	0.0283
0.200	-0.1480	-0.1127	0.0140	0.0140	0.0140	0.0140	0.0140	0.0140	0.0140	0.0140
0.250	*****	-0.1222	-0.0030	-0.2104	-0.2104	-0.2104	-0.2104	-0.2104	-0.2104	-0.2104
0.300	-0.1624	-0.1243	-0.0153	-0.1945	-0.1945	-0.1945	-0.1945	-0.1945	-0.1945	-0.1945
0.350	*****	-0.1327	-0.0299	-0.1875	-0.1875	-0.1875	-0.1875	-0.1875	-0.1875	-0.1875
0.400	-0.1960	-0.1364	-0.0421	-0.1763	-0.1763	-0.1763	-0.1763	-0.1763	-0.1763	-0.1763
0.450	-0.2128	-0.1481	-0.0381	-0.1735	-0.1735	-0.1735	-0.1735	-0.1735	-0.1735	-0.1735
0.500	-0.2333	-0.1543	-0.0736	-0.1719	-0.1719	-0.1719	-0.1719	-0.1719	-0.1719	-0.1719
0.525	*****	-0.1650	-0.0800	-0.1754	-0.1754	-0.1754	-0.1754	-0.1754	-0.1754	-0.1754
0.550	-0.2505	-0.1787	-0.0880	-0.1748	-0.1748	-0.1748	-0.1748	-0.1748	-0.1748	-0.1748
0.575	*****	-0.1856	-0.0873	-0.1818	-0.1818	-0.1818	-0.1818	-0.1818	-0.1818	-0.1818
0.600	-0.2773	-0.1978	-0.1114	-0.1882	-0.1882	-0.1882	-0.1882	-0.1882	-0.1882	-0.1882
0.625	*****	*****	-0.1175	-0.1910	-0.1910	-0.1910	-0.1910	-0.1910	-0.1910	-0.1910
0.650	-0.3022	-0.2134	-0.1336	-0.1981	-0.1981	-0.1981	-0.1981	-0.1981	-0.1981	-0.1981
0.675	*****	-0.2399	-0.1512	-0.2134	-0.2134	-0.2134	-0.2134	-0.2134	-0.2134	-0.2134
0.700	-0.3236	-0.2649	-0.1664	-0.2261	-0.2261	-0.2261	-0.2261	-0.2261	-0.2261	-0.2261
0.725	*****	-0.2933	*****	-0.2436	-0.2436	-0.2436	-0.2436	-0.2436	-0.2436	-0.2436
0.750	-0.3451	-0.3233	*****	-0.2578	-0.2578	-0.2578	-0.2578	-0.2578	-0.2578	-0.2578
0.775	*****	-0.3554	-0.2393	-0.2769	-0.2769	-0.2769	-0.2769	-0.2769	-0.2769	-0.2769
0.800	-0.3603	-0.3913	-0.2767	-0.3037	-0.3037	-0.3037	-0.3037	-0.3037	-0.3037	-0.3037
0.825	*****	-0.4267	-0.3240	-0.3216	-0.3216	-0.3216	-0.3216	-0.3216	-0.3216	-0.3216
0.850	-0.3779	-0.4628	-0.3774	-0.3752	-0.3752	-0.3752	-0.3752	-0.3752	-0.3752	-0.3752
0.875	*****	-0.5038	-0.4400	-0.3972	-0.3972	-0.3972	-0.3972	-0.3972	-0.3972	-0.3972
0.900	-0.4010	-0.5453	-0.5090	-0.4650	-0.4650	-0.4650	-0.4650	-0.4650	-0.4650	-0.4650
0.925	*****	-0.5927	-0.5796	-0.5651	-0.5651	-0.5651	-0.5651	-0.5651	-0.5651	-0.5651
0.950	-0.4331	-0.6367	-0.6616	-0.7014	-0.7014	-0.7014	-0.7014	-0.7014	-0.7014	-0.7014
0.975	*****	-0.7363	-0.9185	-0.9136	-0.9136	-0.9136	-0.9136	-0.9136	-0.9136	-0.9136
1.000	-0.4503	-0.8889	-0.7924	-1.1745	-1.1745	-1.1745	-1.1745	-1.1745	-1.1745	-1.1745
-0.200	$C_{p,l}$	$C_{p,l}$	$C_{p,l}$	$C_{p,l}$	$C_{p,l}$	$C_{p,l}$	$C_{p,l}$	$C_{p,l}$	$C_{p,l}$	$C_{p,l}$
-0.400	0.1379	0.1389	0.1862	0.1862	0.1862	0.1862	0.1862	0.1862	0.1862	0.1862
-0.600	0.1283	0.1459	0.1568	0.0025	-0.0025	-0.0025	-0.0025	-0.0025	-0.0025	-0.0025
-0.700	0.1427	0.1476	0.1488	0.0316	0.0316	0.0316	0.0316	0.0316	0.0316	0.0316
-0.800	0.1621	0.1421	0.1504	0.0491	0.0491	0.0491	0.0491	0.0491	0.0491	0.0491
-0.850	0.1931	*****	0.1462	0.0694	-0.0694	-0.0694	-0.0694	-0.0694	-0.0694	-0.0694
-0.900	*****	0.1819	0.1561	0.0772	-0.0772	-0.0772	-0.0772	-0.0772	-0.0772	-0.0772
-0.950	0.2470	0.2317	0.2118	0.1009	-0.1009	-0.1009	-0.1009	-0.1009	-0.1009	-0.1009
-0.975	*****	0.2101	0.2036	0.1592	-0.1592	-0.1592	-0.1592	-0.1592	-0.1592	-0.1592
-1.000	-0.4722	-0.7523	-1.0481	-1.0802	-1.0802	-1.0802	-1.0802	-1.0802	-1.0802	-1.0802

Medium Radius L.E.
 Run No. = 17, Point No. = 358
 $C_N = 0.297$, $C_m = -0.0505$
 $\alpha = 7.2^\circ$, $M_\infty = 0.849$
 $R_{mac} = 120.0 \times 10^6$

Leading Edge Pressures

● starboard
 ○ port

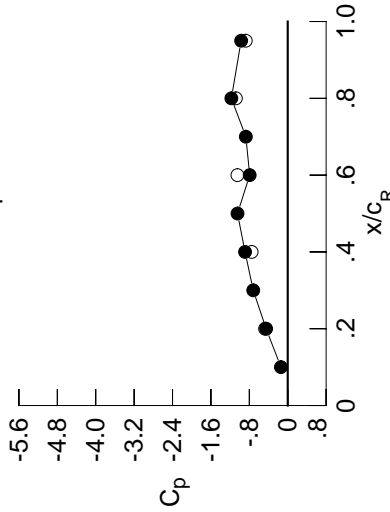

x/c_R	starb'd C_p	port C_p
0.10	-0.1414	*****
0.20	-0.4503	-0.4722
0.30	-0.7186	*****
0.40	-0.8889	-0.7523
0.50	-1.0463	*****
0.60	-0.7924	-1.0481
0.70	-0.8725	*****
0.80	-1.1745	-1.0802
0.90	*****	*****
0.95	-0.9706	-0.8740

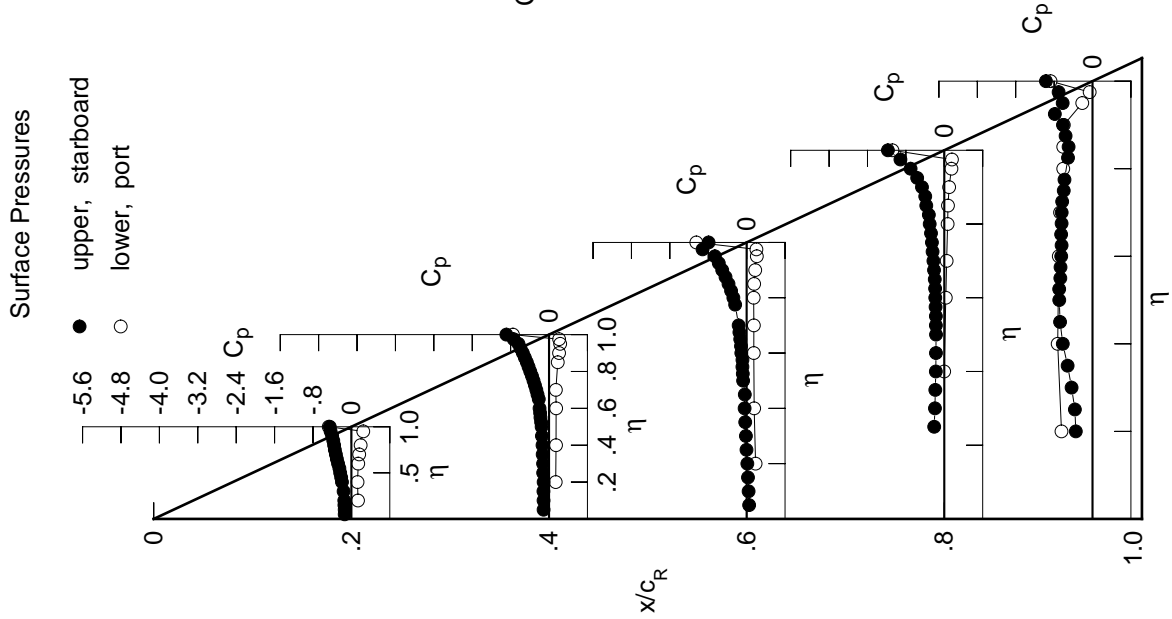

Table E11. Continued.

η	$x/c_R = .2$		$x/c_R = .4$		$x/c_R = .6$		$x/c_R = .8$		$x/c_R = .95$	
	$C_{p,u}$	$C_{p,l}$	$C_{p,u}$	$C_{p,l}$	$C_{p,u}$	$C_{p,l}$	$C_{p,u}$	$C_{p,l}$	$C_{p,u}$	$C_{p,l}$
0.050	-0.1570	-0.1336	0.0339	0.0339	0.0339	0.0339	0.0339	0.0339	0.0339	0.0339
0.100	-0.1604	-0.1355	0.0236	0.0236	0.0236	0.0236	0.0236	0.0236	0.0236	0.0236
0.150	-0.1668	-0.1378	0.0091	0.0091	0.0091	0.0091	0.0091	0.0091	0.0091	0.0091
0.200	-0.1698	-0.1354	-0.0048	-0.0048	-0.0048	-0.0048	-0.0048	-0.0048	-0.0048	-0.0048
0.250	*****	-0.1439	-0.0231	-0.2378	-0.2378	-0.2378	-0.2378	-0.2378	-0.2378	-0.2378
0.300	-0.1846	-0.1474	-0.0348	-0.2211	-0.3929	-0.3929	-0.3929	-0.3929	-0.3929	-0.3929
0.350	*****	-0.1559	-0.0508	-0.2113	-0.5709	-0.5709	-0.5709	-0.5709	-0.5709	-0.5709
0.400	-0.2206	-0.1616	-0.0632	-0.2013	-0.7077	-0.7077	-0.7077	-0.7077	-0.7077	-0.7077
0.450	-0.2394	-0.1727	-0.0581	-0.2014	-0.7423	-0.7423	-0.7423	-0.7423	-0.7423	-0.7423
0.500	-0.2621	-0.1832	-0.1041	-0.2021	-0.5836	-0.5836	-0.5836	-0.5836	-0.5836	-0.5836
0.525	*****	-0.1958	-0.1124	-0.2097	-0.4921	-0.4921	-0.4921	-0.4921	-0.4921	-0.4921
0.550	-0.2828	-0.2119	-0.1236	-0.2174	-0.4057	-0.4057	-0.4057	-0.4057	-0.4057	-0.4057
0.575	*****	-0.2214	-0.1253	-0.2295	-0.4123	-0.4123	-0.4123	-0.4123	-0.4123	-0.4123
0.600	-0.3134	-0.2348	-0.1542	-0.2348	-0.4487	-0.4487	-0.4487	-0.4487	-0.4487	-0.4487
0.625	*****	*****	-0.1632	-0.2255	-0.4870	-0.4870	-0.4870	-0.4870	-0.4870	-0.4870
0.650	-0.3427	-0.2557	-0.1821	-0.2175	-0.4940	-0.4940	-0.4940	-0.4940	-0.4940	-0.4940
0.675	*****	-0.2814	-0.2000	-0.2181	-0.4252	-0.4252	-0.4252	-0.4252	-0.4252	-0.4252
0.700	-0.3699	-0.3059	-0.2129	-0.2137	-0.4257	-0.4257	-0.4257	-0.4257	-0.4257	-0.4257
0.725	*****	-0.3359	*****	-0.2062	-0.4965	-0.4965	-0.4965	-0.4965	-0.4965	-0.4965
0.750	-0.4002	-0.3678	*****	-0.2007	-0.4768	-0.4768	-0.4768	-0.4768	-0.4768	-0.4768
0.775	*****	-0.4040	-0.2718	-0.2833	-0.4833	-0.4833	-0.4833	-0.4833	-0.4833	-0.4833
0.800	-0.4247	-0.4461	-0.3059	-0.5022	*****	*****	*****	*****	*****	*****
0.825	*****	-0.4875	-0.3418	-0.6523	-0.6757	-0.6757	-0.6757	-0.6757	-0.6757	-0.6757
0.850	-0.4502	-0.5306	-0.3918	-0.6098	-0.8260	-0.8260	-0.8260	-0.8260	-0.8260	-0.8260
0.875	*****	-0.5780	-0.5796	-0.4460	-1.2034	-1.2034	-1.2034	-1.2034	-1.2034	-1.2034
0.900	-0.4904	-0.6307	-0.8179	-0.4207	-1.2366	-1.2366	-1.2366	-1.2366	-1.2366	-1.2366
0.925	*****	-0.6837	-0.9588	-0.4819	-1.1730	-1.1730	-1.1730	-1.1730	-1.1730	-1.1730
0.950	-0.5576	-0.7455	-1.0187	-1.0231	-0.8893	-0.8893	-0.8893	-0.8893	-0.8893	-0.8893
0.975	*****	-1.1115	-1.0165	-1.0332	-0.9737	-0.9737	-0.9737	-0.9737	-0.9737	-0.9737
1.000	-0.6712	-1.0964	-0.8676	-1.2557	-1.1546	-1.1546	-1.1546	-1.1546	-1.1546	-1.1546
-0.200	$C_{p,l}$	0.1647	0.1632	0.2059	*****	*****	*****	*****	*****	*****
-0.400		0.1577	0.1712	0.1771	0.0157	-0.7151	-0.7151	-0.7151	-0.7151	-0.7151
-0.600		0.1740	0.1746	0.1702	0.0492	-0.6896	-0.6896	-0.6896	-0.6896	-0.6896
-0.700		0.1950	0.1715	0.1744	0.0675	-0.6608	-0.6608	-0.6608	-0.6608	-0.6608
-0.800		0.2233	*****	0.1726	0.0908	-0.5923	-0.5923	-0.5923	-0.5923	-0.5923
-0.850	*****	0.2117	0.1840	0.1004	-0.5916	-0.5916	-0.5916	-0.5916	-0.5916	-0.5916
-0.900	*****	0.2339	0.2048	0.1249	-0.5752	-0.5752	-0.5752	-0.5752	-0.5752	-0.5752
-0.950		0.2515	0.2414	0.2261	0.1658	-0.2068	-0.2068	-0.2068	-0.2068	-0.2068
-0.975	*****	0.1962	0.2000	0.1645	-0.0655	-0.0655	-0.0655	-0.0655	-0.0655	-0.0655
-1.000		-0.7044	-0.9428	-1.1614	-1.1206	-0.9448	-0.9448	-0.9448	-0.9448	-0.9448

Medium Radius L.E.
 Run No. = 17, Point No. = 359
 $C_N = 0.363$, $C_m = -0.0655$
 $\alpha = 8.3^\circ$, $M_\infty = 0.851$
 $R_{mac} = 120.1 \times 10^6$

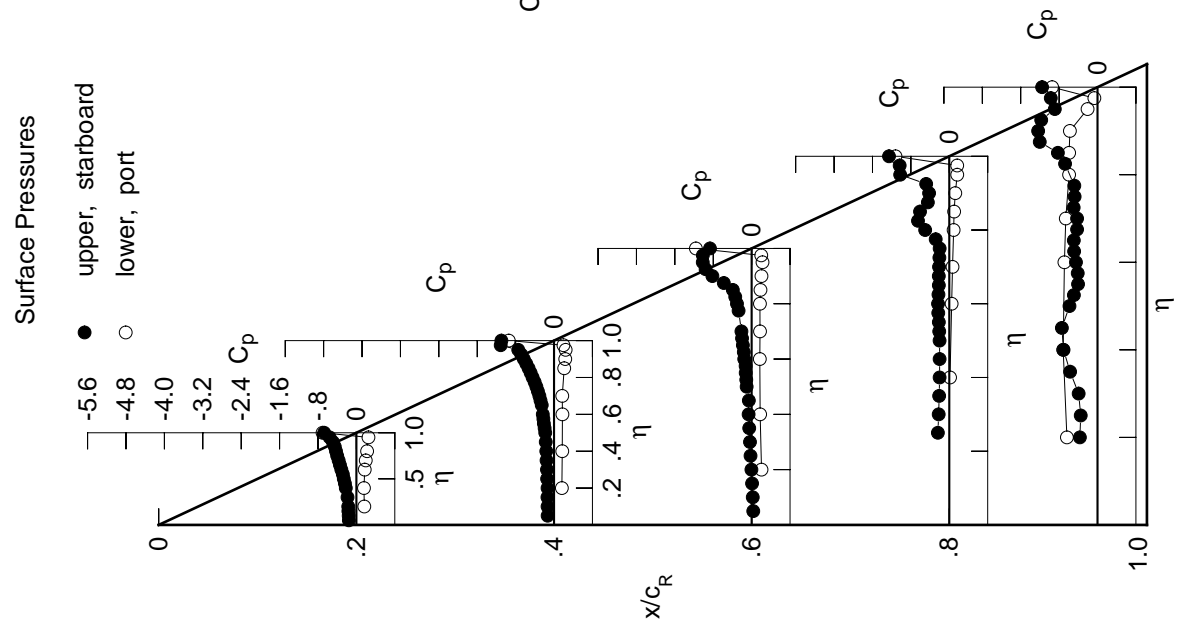
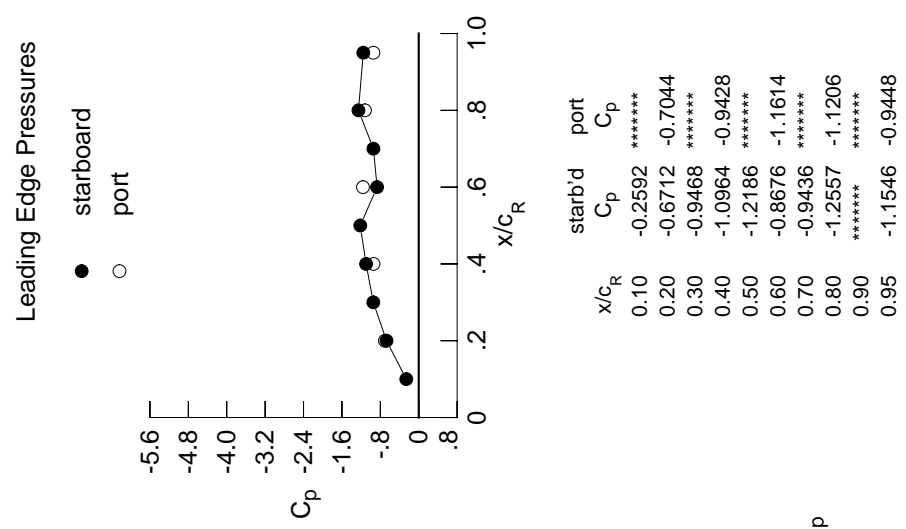
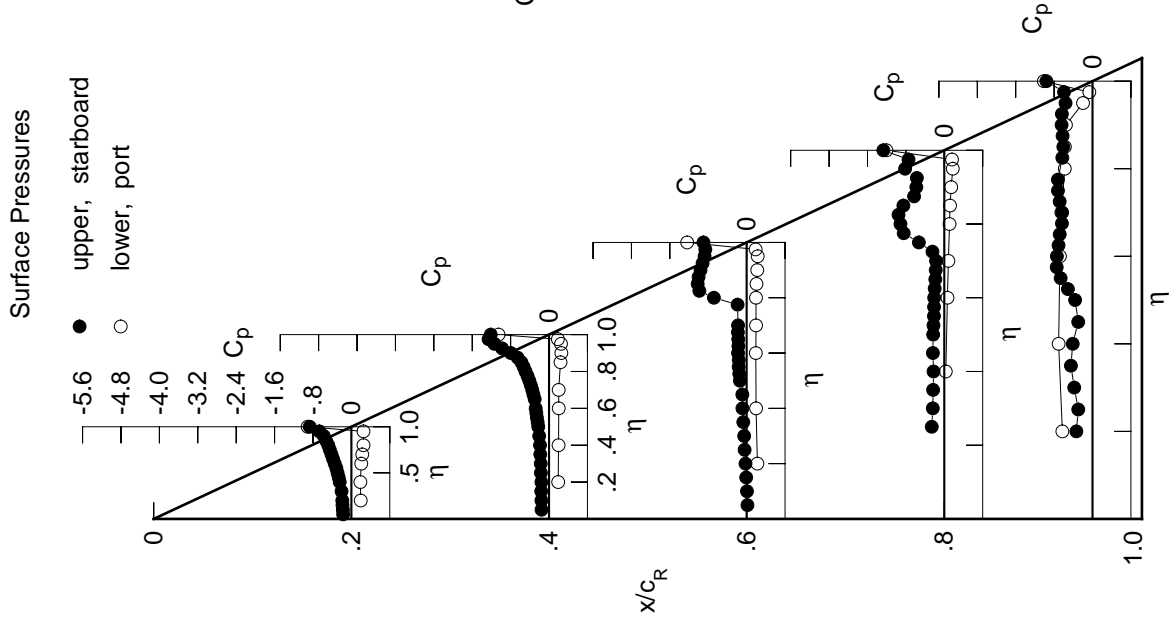
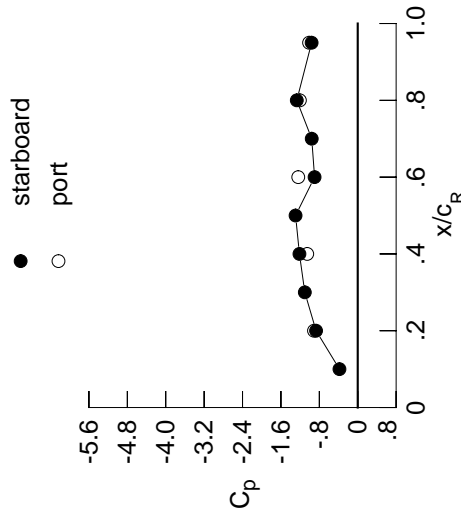

Table E11. Continued.

η	$x/c_R = .2$		$x/c_R = .4$		$x/c_R = .6$		$x/c_R = .8$		$x/c_R = .95$	
	$C_{p,u}$	$C_{p,u}$	$C_{p,u}$	$C_{p,u}$	$C_{p,u}$	$C_{p,u}$	$C_{p,u}$	$C_{p,u}$	$C_{p,u}$	$C_{p,u}$
0.050	-0.1718	-0.1558	0.0169	*****	*****	*****	*****	*****	*****	*****
0.100	-0.1775	-0.1586	0.0060	*****	*****	*****	*****	*****	*****	*****
0.150	-0.1853	-0.1622	-0.0095	*****	*****	*****	*****	*****	*****	*****
0.200	-0.1896	-0.1594	-0.0239	*****	*****	*****	*****	*****	*****	*****
0.250	*****	-0.1693	-0.0422	-0.2606	-0.2967	*****	*****	*****	*****	*****
0.300	-0.2051	-0.1731	-0.0514	-0.2395	-0.3807	*****	*****	*****	*****	*****
0.350	*****	-0.1821	-0.0693	-0.2326	-0.4493	*****	*****	*****	*****	*****
0.400	-0.2435	-0.1883	-0.0883	-0.2237	-0.4123	*****	*****	*****	*****	*****
0.450	-0.2639	-0.2051	-0.0898	-0.2373	-0.2974	*****	*****	*****	*****	*****
0.500	-0.2889	-0.2242	-0.1402	-0.2322	-0.3623	*****	*****	*****	*****	*****
0.525	*****	-0.2374	-0.1536	-0.2246	-0.5125	*****	*****	*****	*****	*****
0.550	-0.3130	-0.2537	-0.1664	-0.2155	-0.6641	*****	*****	*****	*****	*****
0.575	*****	-0.2647	-0.1651	-0.2128	-0.7459	*****	*****	*****	*****	*****
0.600	-0.3473	-0.2782	-0.1789	-0.2107	-0.7413	*****	*****	*****	*****	*****
0.625	*****	*****	-0.1717	-0.2000	-0.7083	*****	*****	*****	*****	*****
0.650	-0.3812	-0.2988	-0.1749	-0.1876	-0.6830	*****	*****	*****	*****	*****
0.675	*****	-0.3258	-0.1813	-0.1781	-0.6371	*****	*****	*****	*****	*****
0.700	-0.4148	-0.3495	-0.1790	-0.1712	-0.6329	*****	*****	*****	*****	*****
0.725	*****	-0.3790	*****	-0.2464	-0.6844	*****	*****	*****	*****	*****
0.750	-0.4497	-0.4110	*****	-0.5296	-0.7200	*****	*****	*****	*****	*****
0.775	*****	-0.4474	-0.1892	-0.8452	-0.7210	*****	*****	*****	*****	*****
0.800	-0.4816	-0.4902	-0.6825	-0.9125	*****	*****	*****	*****	*****	*****
0.825	*****	-0.5295	-0.9853	-0.9538	-0.6291	*****	*****	*****	*****	*****
0.850	-0.5278	-0.5756	-1.0199	-0.8518	-0.6080	*****	*****	*****	*****	*****
0.875	*****	-0.6556	-1.0016	-0.6296	-0.6231	*****	*****	*****	*****	*****
0.900	-0.5760	-0.7967	-0.9604	-0.5821	-0.6439	*****	*****	*****	*****	*****
0.925	*****	-0.9768	-0.9176	-0.5715	-0.6385	*****	*****	*****	*****	*****
0.950	-0.6674	-1.1391	-0.8760	-0.8156	-0.5619	*****	*****	*****	*****	*****
0.975	*****	-1.2600	-0.8605	-0.7457	-0.5931	*****	*****	*****	*****	*****
1.000	-0.8677	-1.2144	-0.8991	-1.2697	-0.9607	*****	*****	*****	*****	*****
-0.200	$C_{p,l}$	$C_{p,l}$	$C_{p,l}$	$C_{p,l}$	$C_{p,l}$	$C_{p,l}$	$C_{p,l}$	$C_{p,l}$	$C_{p,l}$	$C_{p,l}$
-0.400	0.1940	0.1900	0.2241	*****	-0.6278	*****	*****	*****	*****	*****
-0.600	0.1872	0.1983	0.1966	0.0312	-0.7056	*****	*****	*****	*****	*****
-0.700	0.2057	0.2027	0.1909	0.0656	-0.6787	*****	*****	*****	*****	*****
-0.800	0.2262	0.2005	0.1957	0.0850	-0.6487	*****	*****	*****	*****	*****
-0.850	0.2519	*****	0.1941	0.1090	-0.5772	*****	*****	*****	*****	*****
-0.900	*****	0.2395	0.2049	0.1196	-0.5758	*****	*****	*****	*****	*****
-0.950	*****	0.2566	0.2218	0.1443	-0.5533	*****	*****	*****	*****	*****
-0.975	0.2522	0.2497	0.2303	0.1766	-0.1974	*****	*****	*****	*****	*****
-1.000	*****	0.1836	0.1876	0.1605	-0.0663	*****	*****	*****	*****	*****
	-0.9114	-1.0517	-1.2394	-1.2050	-1.0136	*****	*****	*****	*****	*****

Medium Radius L.E.
 Run No. = 17, Point No. = 360
 $C_N = 0.419$, $C_m = -0.0741$
 $\alpha = 9.4^\circ$, $M_\infty = 0.849$
 $R_{mac} = 119.9 \times 10^6$

Leading Edge Pressures



x/c_R	starb'd C_p	port C_p
0.10	-0.3807	*****
0.20	-0.8677	-0.9114
0.30	-1.1028	*****
0.40	-1.2144	-1.0517
0.50	-1.2949	*****
0.60	-0.8991	-1.2394
0.70	-0.9581	*****
0.80	-1.2697	-1.2050
0.90	*****	*****
0.95	-0.9607	-1.0136

Table E11. Continued.

η	$x/c_R = .2$		$x/c_R = .4$		$x/c_R = .6$		$x/c_R = .8$		$x/c_R = .95$	
	$C_{p,u}$	$C_{p,u}$	$C_{p,u}$	$C_{p,u}$	$C_{p,u}$	$C_{p,u}$	$C_{p,u}$	$C_{p,u}$	$C_{p,u}$	$C_{p,u}$
0.050	-0.1884	-0.1861	-0.0100	*****	*****	*****	*****	*****	*****	*****
0.100	-0.1958	-0.1904	-0.0211	*****	*****	*****	*****	*****	*****	*****
0.150	-0.2062	-0.1936	-0.0376	*****	*****	*****	*****	*****	*****	*****
0.200	-0.2118	-0.1935	-0.0503	*****	*****	*****	*****	*****	*****	*****
0.250	*****	-0.2018	-0.0651	-0.2910	-0.2910	-0.3545	*****	*****	*****	*****
0.300	-0.2304	-0.2043	-0.0827	-0.2727	-0.2727	-0.3854	*****	*****	*****	*****
0.350	*****	-0.2178	-0.1048	-0.2735	-0.2735	-0.3220	*****	*****	*****	*****
0.400	-0.2700	-0.2311	-0.1369	-0.2701	-0.2701	-0.2793	*****	*****	*****	*****
0.450	-0.2920	-0.2532	-0.1367	-0.2502	-0.2502	-0.4503	*****	*****	*****	*****
0.500	-0.3199	-0.2713	-0.1539	-0.2404	-0.2404	-0.7320	*****	*****	*****	*****
0.525	*****	-0.2830	-0.1531	-0.2395	-0.2395	-0.7491	*****	*****	*****	*****
0.550	-0.3470	-0.2994	-0.1566	-0.2320	-0.2320	-0.7339	*****	*****	*****	*****
0.575	*****	-0.3051	-0.1477	-0.2288	-0.2288	-0.7271	*****	*****	*****	*****
0.600	-0.3847	-0.3126	-0.1679	-0.2252	-0.2252	-0.7031	*****	*****	*****	*****
0.625	*****	*****	-0.1610	-0.2192	-0.2192	-0.6884	*****	*****	*****	*****
0.650	-0.4236	-0.3172	-0.1573	-0.2365	-0.2365	-0.7294	*****	*****	*****	*****
0.675	*****	-0.3388	-0.1532	-0.3191	-0.3191	-0.8163	*****	*****	*****	*****
0.700	-0.4643	-0.3532	-0.1544	-0.5060	-0.5060	-0.9609	*****	*****	*****	*****
0.725	*****	-0.3680	*****	-0.7648	-1.0818	*****	*****	*****	*****	*****
0.750	-0.5110	-0.3807	*****	-0.9631	-1.0862	*****	*****	*****	*****	*****
0.775	*****	-0.4639	-1.0833	-1.0736	-0.8681	*****	*****	*****	*****	*****
0.800	-0.5576	-0.6886	-1.1395	-1.0504	*****	*****	*****	*****	*****	*****
0.825	*****	-0.9238	-1.1031	-0.9882	-0.6255	*****	*****	*****	*****	*****
0.850	-0.5944	-1.0488	-1.0528	-0.8164	-0.5725	*****	*****	*****	*****	*****
0.875	*****	-1.0978	-0.9979	-0.7400	-0.5697	*****	*****	*****	*****	*****
0.900	-0.6604	-1.1323	-0.9050	-0.7170	-0.5767	*****	*****	*****	*****	*****
0.925	*****	-1.1308	-0.8290	-0.6703	-0.5982	*****	*****	*****	*****	*****
0.950	-0.8113	-1.1265	-0.7842	-0.6850	-0.5447	*****	*****	*****	*****	*****
0.975	*****	-1.1129	-0.7568	-0.6387	-0.5362	*****	*****	*****	*****	*****
1.000	-0.9985	-1.2885	-0.8730	-1.2387	-0.7629	*****	*****	*****	*****	*****
-0.200	$C_{p,l}$	$C_{p,l}$	$C_{p,l}$	$C_{p,l}$	$C_{p,l}$	$C_{p,l}$	$C_{p,l}$	$C_{p,l}$	$C_{p,l}$	$C_{p,l}$
-0.400	0.2237	0.2149	0.2436	*****	*****	-0.6156	*****	*****	*****	*****
-0.600	0.2185	0.2235	0.2166	0.0476	0.0476	-0.6937	*****	*****	*****	*****
-0.700	0.2381	0.2293	0.2121	0.0822	-0.6671	*****	*****	*****	*****	*****
-0.800	0.2584	0.2288	0.2184	0.1018	-0.6372	*****	*****	*****	*****	*****
-0.850	0.2804	*****	0.2183	0.1263	-0.5653	*****	*****	*****	*****	*****
-0.900	*****	0.2652	0.2295	0.1370	-0.5618	*****	*****	*****	*****	*****
-0.950	*****	0.2760	0.2440	0.1602	-0.5325	*****	*****	*****	*****	*****
-0.975	0.2511	0.2541	0.2419	0.1842	-0.1806	*****	*****	*****	*****	*****
-1.000	0.1682	0.1854	0.1565	0.1565	-0.0451	*****	*****	*****	*****	*****
	-1.0661	-1.1148	-1.2563	-1.1907	-0.6534	*****	*****	*****	*****	*****

Medium Radius L.E.
 Run No. = 17, Point No. = 361
 $C_N = 0.486$, $C_m = -0.0852$
 $\alpha = 10.5^\circ$, $M_\infty = 0.852$
 $R_{mac} = 120.1 \times 10^6$

Leading Edge Pressures

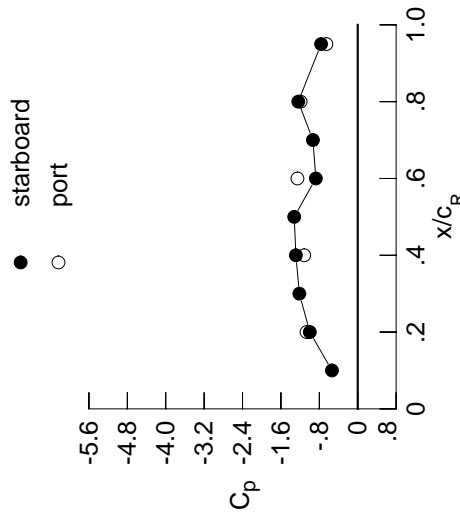

x/c_R	starb'd C_p	port C_p
0.10	-0.5372	*****
0.20	-0.9985	-1.0661
0.30	-1.2157	*****
0.40	-1.2885	-1.1148
0.50	-1.3231	*****
0.60	-0.8730	-1.2563
0.70	-0.9334	*****
0.80	-1.2387	-1.1907
0.90	*****	*****
0.95	-0.7629	-0.6534

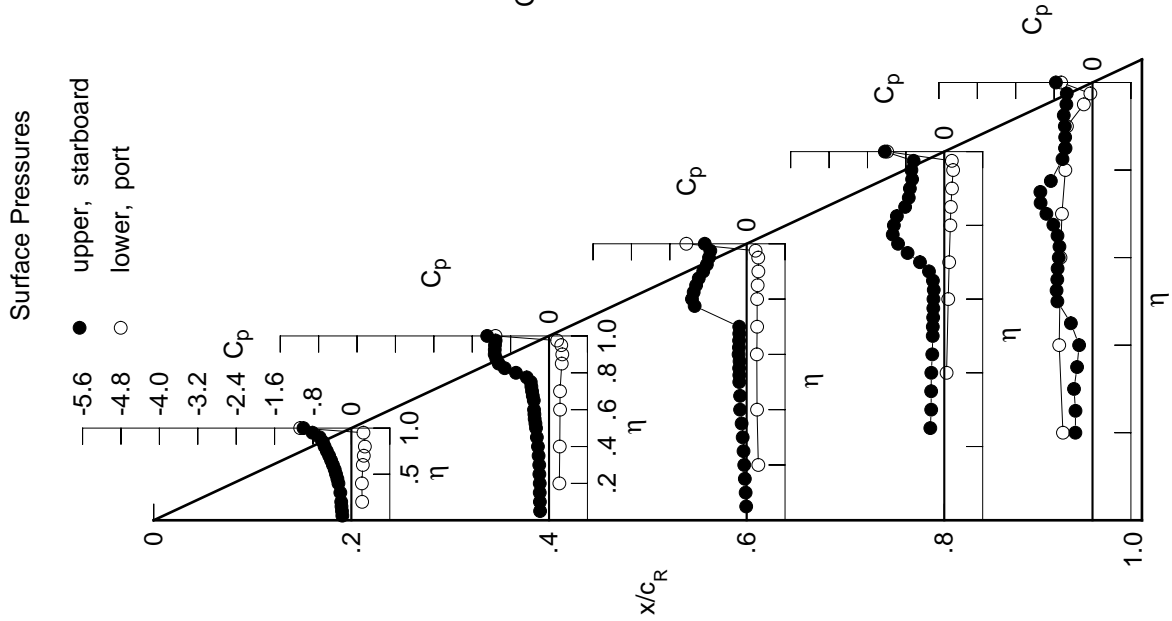
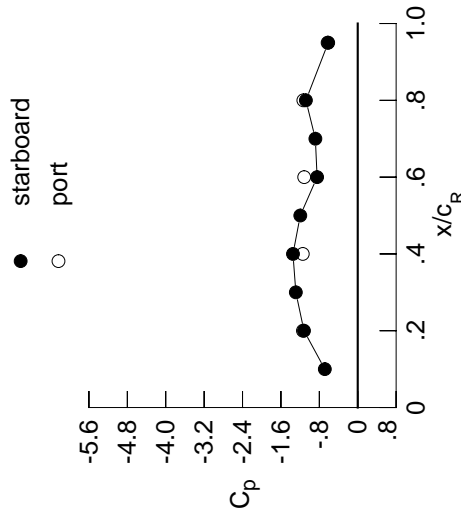

Table E11. Continued.

η	$x/c_R = .2$		$x/c_R = .4$		$x/c_R = .6$		$x/c_R = .8$		$x/c_R = .95$	
	$C_{p,u}$	$C_{p,l}$	$C_{p,u}$	$C_{p,l}$	$C_{p,u}$	$C_{p,l}$	$C_{p,u}$	$C_{p,l}$	$C_{p,u}$	$C_{p,l}$
0.050	-0.2086	-0.2209	-0.0342	*****	*****	*****	*****	*****	*****	*****
0.100	-0.2172	-0.2234	-0.0456	*****	*****	*****	*****	*****	*****	*****
0.150	-0.2306	-0.2283	-0.0631	*****	*****	*****	*****	*****	*****	*****
0.200	-0.2368	-0.2276	-0.0713	*****	*****	*****	*****	*****	*****	*****
0.250	*****	-0.2338	-0.0946	-0.3110	-0.3021	-0.3651	*****	*****	*****	*****
0.300	-0.2584	-0.2437	-0.1161	-0.3021	-0.2948	-0.3082	*****	*****	*****	*****
0.350	*****	-0.2611	-0.1495	-0.2948	-0.2948	-0.3082	*****	*****	*****	*****
0.400	-0.3018	-0.2866	-0.1470	-0.2727	-0.2727	-0.4266	*****	*****	*****	*****
0.450	-0.3252	-0.2944	-0.1258	-0.2625	-0.2625	-0.6923	*****	*****	*****	*****
0.500	-0.3549	-0.2969	-0.1597	-0.2509	-0.2509	-0.7205	*****	*****	*****	*****
0.525	*****	-0.3012	-0.1587	-0.2483	-0.2483	-0.7064	*****	*****	*****	*****
0.550	-0.3831	-0.3077	-0.1569	-0.2407	-0.2407	-0.6856	*****	*****	*****	*****
0.575	*****	-0.3066	-0.1350	-0.2430	-0.2430	-0.6850	*****	*****	*****	*****
0.600	-0.4224	-0.3078	-0.1519	-0.2589	-0.2589	-0.6906	*****	*****	*****	*****
0.625	*****	*****	-0.1472	-0.3033	-0.3033	-0.7403	*****	*****	*****	*****
0.650	-0.4658	-0.2787	-0.2126	-0.4211	-0.4211	-0.8701	*****	*****	*****	*****
0.675	*****	-0.2792	-0.4177	-0.6384	-1.0160	*****	*****	*****	*****	*****
0.700	-0.5140	-0.3017	-0.7260	-0.8801	-1.1599	*****	*****	*****	*****	*****
0.725	*****	-0.5631	*****	-1.0657	-1.2392	*****	*****	*****	*****	*****
0.750	-0.5682	-0.9498	*****	-1.1444	-0.9257	*****	*****	*****	*****	*****
0.775	*****	-1.1141	-1.1609	-1.1486	-0.7127	*****	*****	*****	*****	*****
0.800	-0.6042	-1.1680	-1.1159	-1.0437	*****	*****	*****	*****	*****	*****
0.825	*****	-1.1734	-1.0712	-0.9184	-0.5577	*****	*****	*****	*****	*****
0.850	-0.6502	-1.1523	-1.0009	-0.7964	-0.5223	*****	*****	*****	*****	*****
0.875	*****	-1.1340	-0.9354	-0.7706	-0.5278	*****	*****	*****	*****	*****
0.900	-0.8330	-1.1181	-0.8636	-0.7432	-0.5368	*****	*****	*****	*****	*****
0.925	*****	-1.0855	-0.8159	-0.6731	-0.5575	*****	*****	*****	*****	*****
0.950	-1.2009	-1.0650	-0.7808	-0.6833	-0.5127	*****	*****	*****	*****	*****
0.975	*****	-1.0423	-0.7540	-0.6316	-0.4641	*****	*****	*****	*****	*****
1.000	-1.1198	-1.3492	-0.8465	-1.0796	-0.6152	*****	*****	*****	*****	*****
-0.200	$C_{p,l}$	0.2544	0.2405	0.2605	*****	*****	*****	*****	*****	*****
-0.400	$C_{p,l}$	0.2506	0.2498	0.2342	0.0617	-0.6868	*****	*****	*****	*****
-0.600	$C_{p,l}$	0.2705	0.2557	0.2308	0.0954	-0.6606	*****	*****	*****	*****
-0.700	$C_{p,l}$	0.2902	0.2572	0.2379	0.1155	-0.6302	*****	*****	*****	*****
-0.800	$C_{p,l}$	0.3082	*****	0.2380	0.1391	-0.5563	*****	*****	*****	*****
-0.850	$C_{p,l}$	*****	0.2900	0.2488	0.1500	-0.5502	*****	*****	*****	*****
-0.900	$C_{p,l}$	*****	0.2951	0.2601	0.1716	-0.5162	*****	*****	*****	*****
-0.950	$C_{p,l}$	0.2485	0.2599	0.2475	0.1870	-0.1743	*****	*****	*****	*****
-0.975	$C_{p,l}$	*****	0.1587	0.1805	0.1473	-0.0475	*****	*****	*****	*****
-1.000	$C_{p,l}$	-1.1416	-1.1446	-1.1155	-1.1328	-0.6274	*****	*****	*****	*****

Medium Radius L.E.
 Run No. = 17, Point No. = 362
 $C_N = 0.548$, $C_m = -0.0922$
 $\alpha = 11.5^\circ$, $M_\infty = 0.850$
 $R_{mac} = 120.0 \times 10^6$

Leading Edge Pressures



x/c_R	starb'd C_p	port C_p
0.10	-0.6858	*****
0.20	-1.1198	-1.1416
0.30	-1.2894	*****
0.40	-1.3492	-1.1446
0.50	-1.1969	*****
0.60	-0.8465	-1.1155
0.70	-0.8826	*****
0.80	-1.0796	-1.1328
0.90	*****	*****
0.95	-0.6152	-0.6274

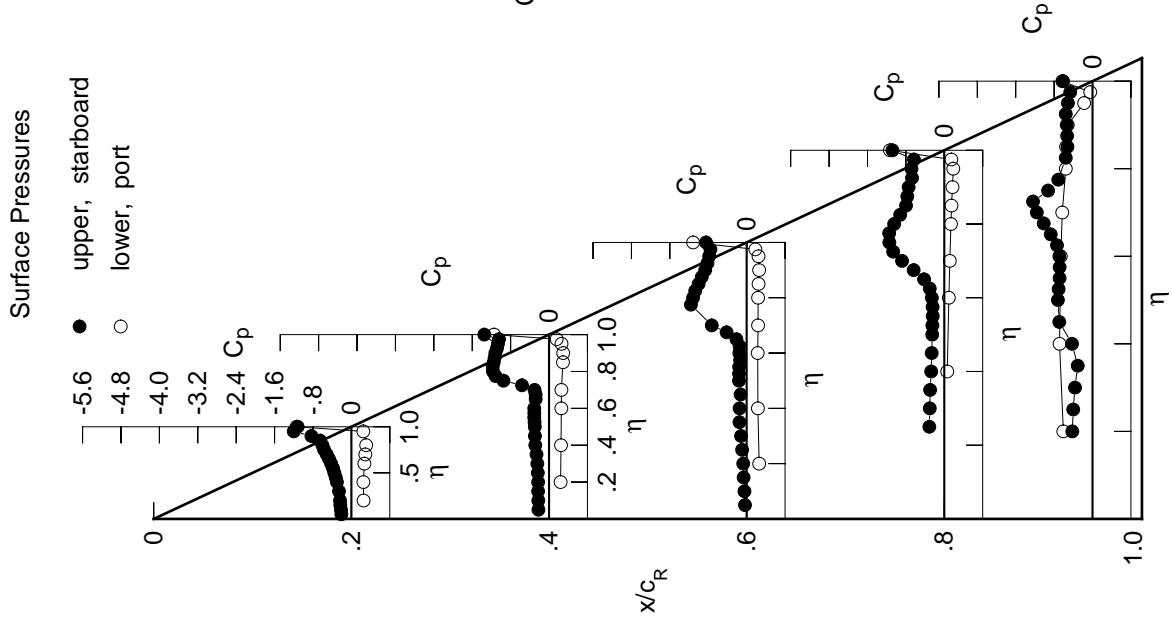

Table E11. Continued.

η	$x/c_R = .2$		$x/c_R = .4$		$x/c_R = .6$		$x/c_R = .8$		$x/c_R = .95$	
	$C_{p,u}$	$C_{p,u}$	$C_{p,u}$	$C_{p,u}$	$C_{p,u}$	$C_{p,u}$	$C_{p,u}$	$C_{p,u}$	$C_{p,u}$	$C_{p,u}$
0.050	-0.2309	-0.2571	-0.0552	*****	*****	*****	*****	*****	*****	*****
0.100	-0.2364	-0.2578	-0.0666	*****	*****	*****	*****	*****	*****	*****
0.150	-0.2543	-0.2615	-0.0824	*****	*****	*****	*****	*****	*****	*****
0.200	-0.2641	-0.2599	-0.0968	*****	*****	*****	*****	*****	*****	*****
0.250	*****	-0.2708	-0.1162	-0.3370	-0.4874	*****	*****	*****	*****	-0.5017
0.300	-0.2918	-0.2836	-0.1427	-0.3269	-0.4899	*****	*****	*****	*****	*****
0.350	*****	-0.3099	-0.1754	-0.3199	-0.4708	*****	*****	*****	*****	*****
0.400	-0.3386	-0.3197	-0.1786	-0.2980	-0.5615	*****	*****	*****	*****	*****
0.450	-0.3582	-0.3509	-0.1590	-0.2863	-0.7098	*****	*****	*****	*****	*****
0.500	-0.3860	-0.3598	-0.1802	-0.2741	-0.7044	*****	*****	*****	*****	*****
0.525	*****	-0.3552	-0.1782	-0.2736	-0.6956	*****	*****	*****	*****	*****
0.550	-0.4151	-0.3657	-0.1760	-0.2729	-0.6845	*****	*****	*****	*****	*****
0.575	*****	-0.3608	-0.1572	-0.2894	-0.7024	*****	*****	*****	*****	*****
0.600	-0.4560	-0.3529	-0.1982	-0.3312	-0.7369	*****	*****	*****	*****	*****
0.625	*****	*****	-0.2431	-0.4184	-0.8197	*****	*****	*****	*****	*****
0.650	-0.5048	-0.3214	-0.4236	-0.5824	-0.9630	*****	*****	*****	*****	*****
0.675	*****	-0.3187	-0.7252	-0.8174	-1.0993	*****	*****	*****	*****	*****
0.700	-0.5479	-0.3296	-0.9874	-1.0469	-0.9583	*****	*****	*****	*****	*****
0.725	*****	-0.6697	*****	-1.2256	-0.7223	*****	*****	*****	*****	*****
0.750	-0.5854	-1.2074	*****	-1.3027	-0.6257	*****	*****	*****	*****	*****
0.775	*****	-1.3385	-1.2818	-1.0575	-0.5587	*****	*****	*****	*****	*****
0.800	-0.6449	-1.2804	-1.1912	-0.9113	*****	*****	*****	*****	*****	*****
0.825	*****	-1.3339	-1.1398	-0.8381	-0.5379	*****	*****	*****	*****	*****
0.850	-0.9483	-1.2844	-1.0452	-0.8144	-0.5074	*****	*****	*****	*****	*****
0.875	*****	-1.2392	-0.9517	-0.8060	-0.5265	*****	*****	*****	*****	*****
0.900	-1.1738	-1.1852	-0.8997	-0.7521	-0.5554	*****	*****	*****	*****	*****
0.925	*****	-1.1380	-0.8559	-0.7191	-0.5648	*****	*****	*****	*****	*****
0.950	-1.2765	-1.0993	-0.8114	-0.7634	-0.4849	*****	*****	*****	*****	*****
0.975	*****	-1.0777	-0.7856	-0.6785	-0.4178	*****	*****	*****	*****	*****
1.000	-1.2049	-1.3619	-0.8378	-1.0789	-0.5236	*****	*****	*****	*****	*****
-0.200	$C_{p,l}$	$C_{p,l}$	$C_{p,l}$	$C_{p,l}$	$C_{p,l}$	$C_{p,l}$	$C_{p,l}$	$C_{p,l}$	$C_{p,l}$	$C_{p,l}$
-0.400	0.2854	0.2659	0.2792	*****	*****	*****	*****	*****	*****	-0.5965
-0.600	0.2826	0.2751	0.2532	0.0780	0.6765	*****	*****	*****	*****	*****
-0.700	0.3026	0.2814	0.2505	0.1107	-0.6515	*****	*****	*****	*****	*****
-0.800	0.3206	0.2832	0.2574	0.1310	-0.6201	*****	*****	*****	*****	*****
-0.850	0.3348	*****	0.2579	0.1547	-0.5447	*****	*****	*****	*****	*****
-0.900	*****	0.3120	0.2668	0.1659	-0.5358	*****	*****	*****	*****	*****
-0.950	*****	0.3107	0.2739	0.1853	-0.4973	*****	*****	*****	*****	*****
-0.975	0.2473	0.2628	0.2487	0.1909	-0.1648	*****	*****	*****	*****	*****
-1.000	*****	0.1451	0.1670	0.1370	-0.0460	*****	*****	*****	*****	*****
	-1.1942	-1.1281	-1.0293	-1.0537	-0.5578	*****	*****	*****	*****	*****

Medium Radius L.E.
 Run No. = 17, Point No. = 363
 $C_N = 0.603$, $C_m = -0.0980$
 $\alpha = 12.6^\circ$, $M_\infty = 0.850$
 $R_{mac} = 120.0 \times 10^6$

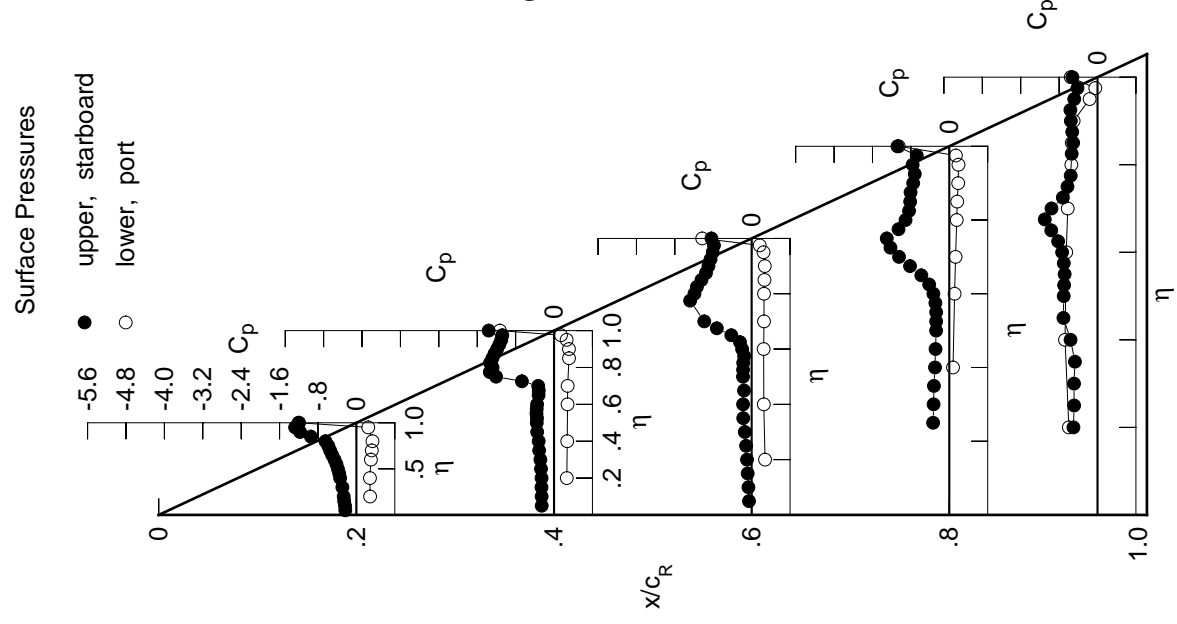
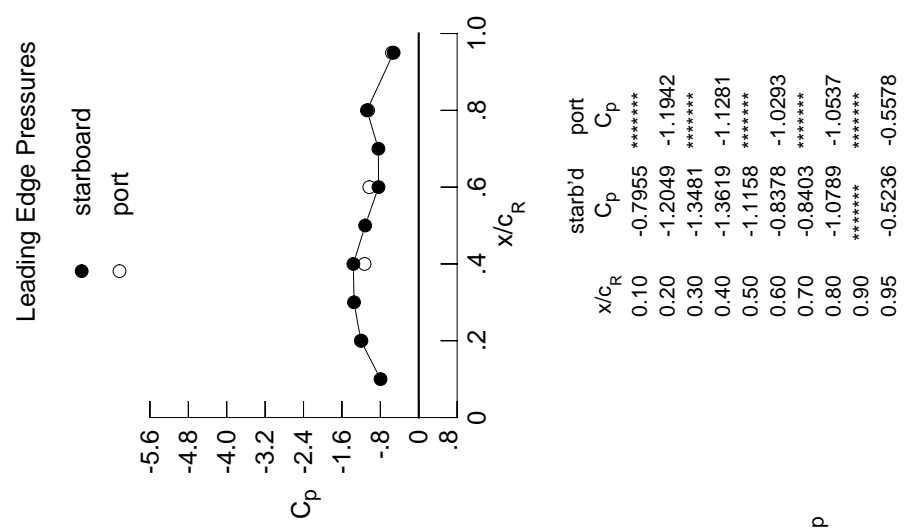
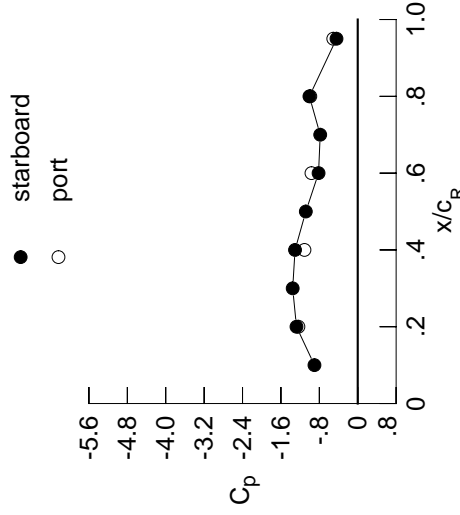

Table E11. Continued.

η	$x/c_R = .2$		$x/c_R = .4$		$x/c_R = .6$		$x/c_R = .8$		$x/c_R = .95$	
	$C_{p,u}$	$C_{p,u}$	$C_{p,u}$	$C_{p,u}$	$C_{p,u}$	$C_{p,u}$	$C_{p,u}$	$C_{p,u}$	$C_{p,u}$	$C_{p,u}$
0.050	-0.2587	-0.3031	-0.0767	*****	*****	*****	*****	*****	*****	*****
0.100	-0.2590	-0.3042	-0.0884	*****	*****	*****	*****	*****	*****	*****
0.150	-0.2774	-0.3040	-0.1041	*****	*****	*****	*****	*****	*****	*****
0.200	-0.2931	-0.3046	-0.1168	*****	*****	*****	*****	*****	*****	*****
0.250	*****	-0.3217	-0.1505	-0.3750	-0.4739	*****	*****	*****	*****	-0.5846
0.300	-0.3369	-0.3497	-0.1571	-0.3575	-0.3790	*****	*****	*****	*****	*****
0.350	*****	-0.3439	-0.1632	-0.3405	-0.4870	*****	*****	*****	*****	*****
0.400	-0.3722	-0.3356	-0.1704	-0.3225	-0.6871	*****	*****	*****	*****	*****
0.450	-0.3868	-0.3334	-0.1523	-0.3136	-0.7071	*****	*****	*****	*****	*****
0.500	-0.4119	-0.3302	-0.2045	-0.3156	-0.6974	*****	*****	*****	*****	*****
0.525	*****	-0.3496	-0.2235	-0.3323	-0.7087	*****	*****	*****	*****	*****
0.550	-0.4408	-0.3821	-0.2672	-0.3668	-0.7380	*****	*****	*****	*****	*****
0.575	*****	-0.4011	-0.3379	-0.4430	-0.8144	*****	*****	*****	*****	*****
0.600	-0.4787	-0.4517	-0.5465	-0.5689	-0.9140	*****	*****	*****	*****	*****
0.625	*****	*****	-0.7396	-0.7416	-1.0402	*****	*****	*****	*****	*****
0.650	-0.5117	-0.7611	-0.9765	-0.9413	-1.1888	*****	*****	*****	*****	*****
0.675	*****	-0.9975	-1.1532	-1.1284	-1.1663	*****	*****	*****	*****	*****
0.700	-0.5335	-1.1775	-1.2254	-1.2637	-0.8966	*****	*****	*****	*****	*****
0.725	*****	-1.2485	*****	-1.3201	-0.8102	*****	*****	*****	*****	*****
0.750	-0.7297	-1.2585	*****	-1.2379	-0.7093	*****	*****	*****	*****	*****
0.775	*****	-1.2399	-1.2170	-1.0481	-0.6154	*****	*****	*****	*****	*****
0.800	-1.0773	-1.2120	-1.1587	-0.9246	*****	*****	*****	*****	*****	*****
0.825	*****	-1.1821	-1.0805	-0.8528	-0.5404	*****	*****	*****	*****	*****
0.850	-1.2430	-1.1554	-0.9861	-0.8279	-0.5041	*****	*****	*****	*****	*****
0.875	*****	-1.1267	-0.9374	-0.8193	-0.5131	*****	*****	*****	*****	*****
0.900	-1.2760	-1.1000	-0.9003	-0.7849	-0.5114	*****	*****	*****	*****	*****
0.925	*****	-1.0778	-0.8559	-0.7289	-0.5038	*****	*****	*****	*****	*****
0.950	-1.2769	-1.0547	-0.8102	-0.7591	-0.4398	*****	*****	*****	*****	*****
0.975	*****	-1.0402	-0.7816	-0.6763	-0.3704	*****	*****	*****	*****	*****
1.000	-1.2761	-1.3061	-0.8162	-1.0068	-0.4423	*****	*****	*****	*****	*****
-0.200	$C_{p,l}$	$C_{p,l}$	$C_{p,l}$	$C_{p,l}$	$C_{p,l}$	$C_{p,l}$	$C_{p,l}$	$C_{p,l}$	$C_{p,l}$	$C_{p,l}$
-0.400	0.3183	0.2923	0.2987	*****	-0.5836	*****	*****	*****	*****	*****
-0.600	0.3166	0.3014	0.2736	0.0939	-0.6657	*****	*****	*****	*****	*****
-0.700	0.3361	0.3077	0.2701	0.1274	-0.6410	*****	*****	*****	*****	*****
-0.800	0.3523	0.3100	0.2784	0.1468	-0.6085	*****	*****	*****	*****	*****
-0.850	0.3613	*****	0.2776	0.1712	-0.5323	*****	*****	*****	*****	*****
-0.900	*****	0.3333	0.2851	0.1807	-0.5207	*****	*****	*****	*****	*****
-0.950	*****	0.3255	0.2868	0.1980	-0.4785	*****	*****	*****	*****	*****
-0.975	0.2461	0.2635	0.2486	0.1923	-0.1559	*****	*****	*****	*****	*****
-1.000	*****	0.1289	0.1521	0.1243	-0.0473	*****	*****	*****	*****	*****
-1.000	-1.2363	-1.1092	-0.9644	-0.9883	-0.5095	*****	*****	*****	*****	*****

Medium Radius L.E.
 Run No. = 17, Point No. = 364
 $C_N = 0.667$, $C_m = -0.1065$
 $\alpha = 13.7^\circ$, $M_\infty = 0.851$
 $R_{mac} = 119.9 \times 10^6$

Leading Edge Pressures



x/c_R	starb'd C_p	port C_p
0.10	-0.9015	*****
0.20	-1.2761	-1.2363
0.30	-1.3548	*****
0.40	-1.3061	-1.1092
0.50	-1.0813	*****
0.60	-0.8162	-0.9644
0.70	-0.7819	*****
0.80	-1.0068	-0.9883
0.90	*****	*****
0.95	-0.4423	-0.5095

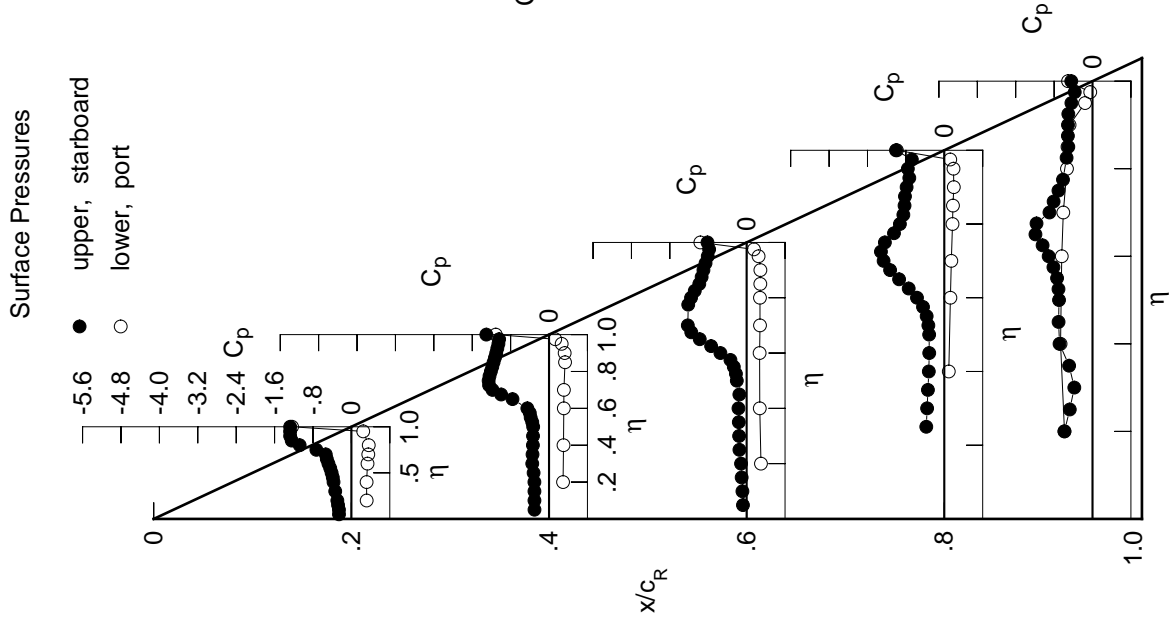
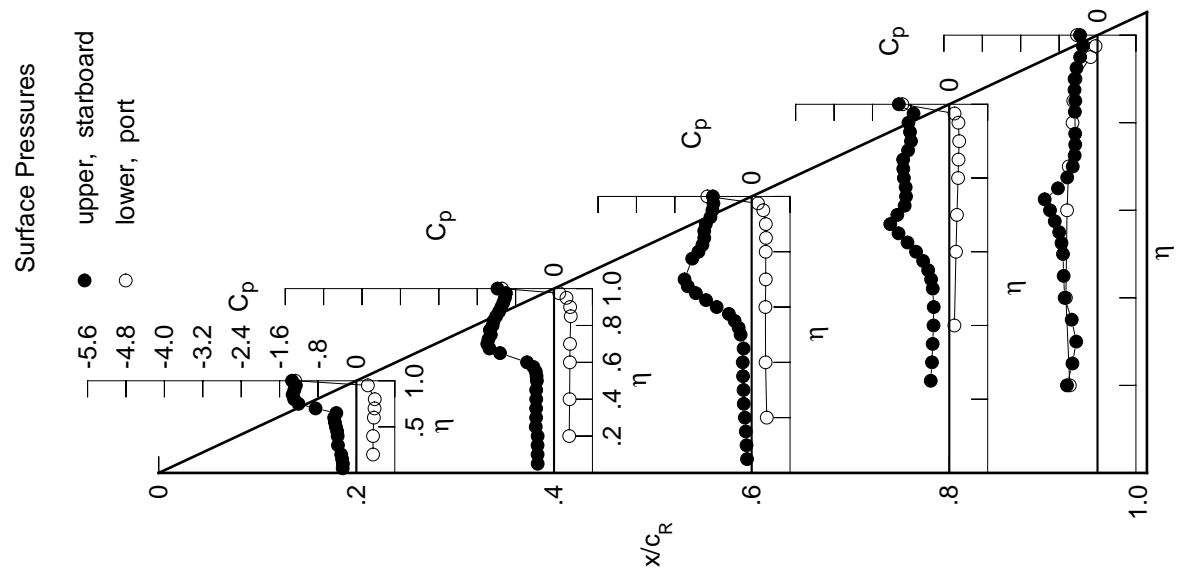
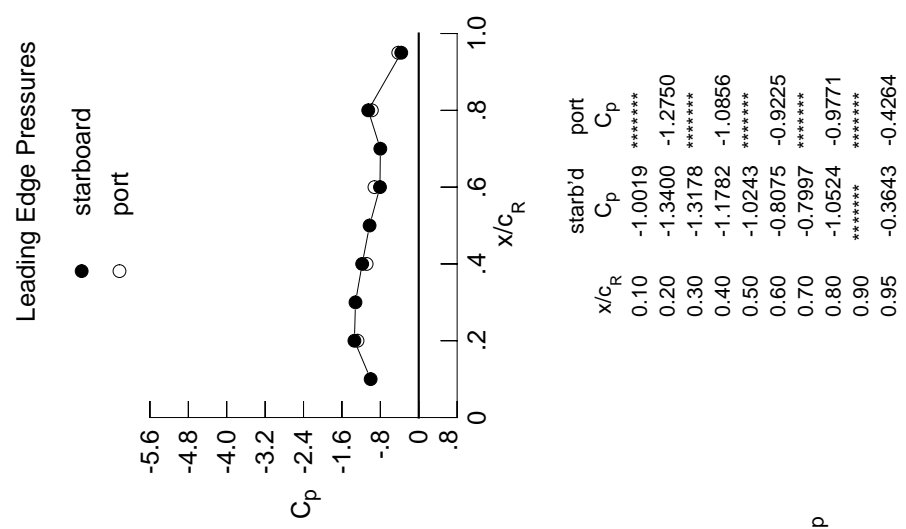

Table E11. Concluded.

η	$x/c_R = .2$		$x/c_R = .4$		$x/c_R = .6$		$x/c_R = .8$		$x/c_R = .95$	
	$C_{p,u}$	$C_{p,u}$	$C_{p,u}$	$C_{p,u}$	$C_{p,u}$	$C_{p,u}$	$C_{p,u}$	$C_{p,u}$	$C_{p,u}$	$C_{p,u}$
0.050	-0.2853	-0.3409	-0.0958	*****	*****	*****	*****	*****	*****	*****
0.100	-0.2805	-0.3424	-0.1062	*****	*****	*****	*****	*****	*****	*****
0.150	-0.2978	-0.3429	-0.1213	*****	*****	*****	*****	*****	*****	*****
0.200	-0.3158	-0.3413	-0.1407	*****	*****	*****	*****	*****	*****	*****
0.250	*****	-0.3807	-0.1650	-0.3866	-0.5222	*****	*****	*****	*****	-0.6366
0.300	-0.3838	-0.3725	-0.1688	-0.3611	-0.4429	*****	*****	*****	*****	*****
0.350	*****	-0.3736	-0.1790	-0.3466	-0.5376	*****	*****	*****	*****	*****
0.400	-0.3901	-0.3713	-0.1859	-0.3286	-0.6851	*****	*****	*****	*****	*****
0.450	-0.3997	-0.3721	-0.1676	-0.3250	-0.7055	*****	*****	*****	*****	*****
0.500	-0.4272	-0.3578	-0.2296	-0.3446	-0.7196	*****	*****	*****	*****	*****
0.525	*****	-0.3639	-0.2704	-0.3790	-0.7503	*****	*****	*****	*****	*****
0.550	-0.4477	-0.3811	-0.3543	-0.4400	-0.7986	*****	*****	*****	*****	*****
0.575	*****	-0.4303	-0.4740	-0.5449	-0.8903	*****	*****	*****	*****	*****
0.600	-0.4630	-0.5624	-0.7285	-0.6929	-0.9896	*****	*****	*****	*****	*****
0.625	*****	*****	-0.9507	-0.8705	-1.1006	*****	*****	*****	*****	*****
0.650	-0.4173	-1.1246	-1.1623	-1.0579	-0.8238	*****	*****	*****	*****	*****
0.675	*****	-1.3457	-1.3306	-1.2297	-0.6314	*****	*****	*****	*****	*****
0.700	-0.8508	-1.3901	-1.3977	-1.0835	-0.5163	*****	*****	*****	*****	*****
0.725	*****	-1.3675	*****	-0.9294	-0.4760	*****	*****	*****	*****	*****
0.750	-1.2054	-1.3176	*****	-0.9013	-0.4642	*****	*****	*****	*****	*****
0.775	*****	-1.3372	-1.2383	-0.9091	-0.4650	*****	*****	*****	*****	*****
0.800	-1.2962	-1.2791	-1.1071	-0.9463	*****	*****	*****	*****	*****	*****
0.825	*****	-1.2600	-1.0249	-0.9587	-0.4721	*****	*****	*****	*****	*****
0.850	-1.3280	-1.2054	-0.9861	-0.9614	-0.4621	*****	*****	*****	*****	*****
0.875	*****	-1.1453	-0.9878	-0.8585	-0.4791	*****	*****	*****	*****	*****
0.900	-1.2927	-1.0970	-0.9550	-0.7979	-0.4776	*****	*****	*****	*****	*****
0.925	*****	-1.0560	-0.8582	-0.8187	-0.4371	*****	*****	*****	*****	*****
0.950	-1.2611	-1.0233	-0.8171	-0.8514	-0.3619	*****	*****	*****	*****	*****
0.975	*****	-1.0022	-0.7958	-0.7448	-0.3067	*****	*****	*****	*****	*****
1.000	-1.3400	-1.1782	-0.8075	-1.0524	-0.3643	*****	*****	*****	*****	*****
-0.200	$C_{p,l}$	$C_{p,l}$	$C_{p,l}$	$C_{p,l}$	$C_{p,l}$	$C_{p,l}$	$C_{p,l}$	$C_{p,l}$	$C_{p,l}$	$C_{p,l}$
-0.400	0.3471	0.3157	0.3148	*****	-0.5772	*****	*****	*****	*****	*****
-0.600	0.3464	0.3241	0.2902	0.1066	-0.6589	*****	*****	*****	*****	*****
-0.700	0.3644	0.3307	0.2868	0.1398	-0.6343	*****	*****	*****	*****	*****
-0.800	0.3782	0.3326	0.2945	0.1593	-0.5999	*****	*****	*****	*****	*****
-0.850	0.3825	*****	0.2927	0.1833	-0.5211	*****	*****	*****	*****	*****
-0.900	*****	0.3491	0.2986	0.1922	-0.5051	*****	*****	*****	*****	*****
-0.950	*****	0.3348	0.2953	0.2063	-0.4595	*****	*****	*****	*****	*****
-0.975	0.2388	0.2593	0.2435	0.1906	-0.1435	*****	*****	*****	*****	*****
-1.000	*****	0.1092	0.1325	0.1084	-0.0408	*****	*****	*****	*****	*****
	-1.2750	-1.0856	-0.9225	-0.9771	-0.4264	*****	*****	*****	*****	*****

Medium Radius L.E.
 Run No. = 17, Point No. = 365
 $C_N = 0.703$, $C_m = -0.1025$
 $\alpha = 14.8^\circ$, $M_\infty = 0.851$
 $R_{mac} = 119.8 \times 10^6$



Appendix F

Experimental Surface Pressure Data for 65° Delta Wing, $R_{\text{mac}} = 6 \times 10^6$

The experimental surface pressure data for the 65° delta wing at constant $R_{\text{mac}} = 6 \times 10^6$ are summarized in tables F1–F4. Because of the extensive data contained in these tables, they have not been included in the printed copy of the paper but are available electronically from the Langley Technical Report Server (LTRS). Open the files with the following Uniform Resource Locator (URL):

<ftp://techreports.larc.nasa.gov/pub/techreports/larc/96/NASA-96-tm4645vol3appF.ps.Z>

Table F1. Tabulations and Plots of Surface Pressure Coefficients.

η	x/c_R .2	$C_{p,u}$	x/c_R .4	$C_{p,u}$	x/c_R .6	$C_{p,u}$	x/c_R .8	$C_{p,u}$	x/c_R .95
0.050		-0.0087	0.0056	0.1222	0.1222	0.1222	0.1222	0.1222	0.1222
0.100		-0.0089	0.0050	0.1112	0.1112	0.1112	0.1112	0.1112	0.1112
0.150		-0.0122	0.0037	0.1022	0.1022	0.1022	0.1022	0.1022	0.1022
0.200		-0.0149	0.0046	0.0884	0.0884	0.0884	0.0884	0.0884	0.0884
0.250		0.0000	0.0042	0.0736	-0.1255	-0.3127			
0.300		-0.0267	0.0046	0.0648	-0.1104	-0.3491			
0.350		0.0000	0.0022	0.0523	-0.0972	-0.3683			
0.400		-0.0350	0.0016	0.0462	-0.0865	-0.3824			
0.450		-0.0384	-0.0007	0.0404	-0.0841	-0.3976			
0.500		-0.0477	0.0007	0.0308	-0.0769	-0.4132			
0.525		0.0000	-0.0031	0.0272	-0.0785	-0.4188			
0.550		-0.0530	-0.0035	0.0244	-0.0752	-0.4251			
0.575		0.0000	-0.0072	0.0230	-0.0778	-0.4344			
0.600		-0.0548	-0.0093	0.0176	-0.0712	-0.4430			
0.625		0.0000	0.0000	0.0153	-0.0719	-0.4444			
0.650		-0.0556	-0.0301	0.0140	-0.0710	-0.4438			
0.675		0.0000	-0.0396	0.0080	-0.0725	-0.4380			
0.700		-0.0501	-0.0407	0.0082	-0.0699	-0.4328			
0.725		0.0000	-0.0469	0.0000	-0.0699	-0.4171			
0.750		-0.0413	-0.0530	0.0000	-0.0724	-0.3839			
0.775		0.0000	-0.0583	-0.0280	-0.0741	-0.3318			
0.800		-0.0257	-0.0577	-0.0353	-0.0773	0.0000			
0.825		0.0000	-0.0623	-0.0438	-0.0916	-0.3372			
0.850		-0.0031	-0.0585	-0.0533	-0.1036	-0.4933			
0.875		0.0000	-0.0475	-0.0592	-0.1154	-0.5415			
0.900		0.0298	-0.0352	-0.0556	-0.1188	-0.6920			
0.925		0.0000	-0.0111	-0.0396	-0.1147	-0.7789			
0.950		0.0773	0.0235	-0.0096	-0.0842	-0.4137			
0.975		0.0000	0.0751	0.0478	-0.0233	-0.2170			
1.000		0.1972	0.1865	0.1379	0.1325	0.0677			
η	$C_{p,l}$	$C_{p,l}$	$C_{p,l}$	$C_{p,l}$	$C_{p,l}$	$C_{p,l}$	$C_{p,l}$	$C_{p,l}$	$C_{p,l}$
-0.200	-0.0356	-0.0121	0.0701	0.0000	0.0000	-0.2679			
-0.400	-0.0616	-0.0114	0.0248	-0.1040	-0.3635				
-0.600	-0.0898	-0.0258	-0.0029	-0.0860	-0.3843				
-0.700	-0.0898	-0.0741	-0.0160	-0.0922	-0.4781				
-0.800	-0.0758	-0.1042	-0.0758	-0.1007	-0.5773				
-0.850	-0.0568	-0.1059	-0.1002	-0.1423	-0.5578				
-0.900	0.0000	-0.0944	-0.1157	-0.1738	-0.5425				
-0.950	0.0215	-0.0476	-0.0869	-0.1629	-0.3885				
-0.975	0.0000	0.0046	-0.0375	-0.1113	-0.2540				
-1.000	0.1882	0.1725	0.1460	0.1230	0.0760				

Medium Radius L.E.
 Run No. = 5, Point No. = 82
 $C_N = -0.022$, $C_M = -0.0010$
 $\alpha = -0.5^\circ$, $M_\infty = 0.799$
 $R_{mac} = 6.0 \times 10^6$

Leading Edge Pressures

- starboard
- port

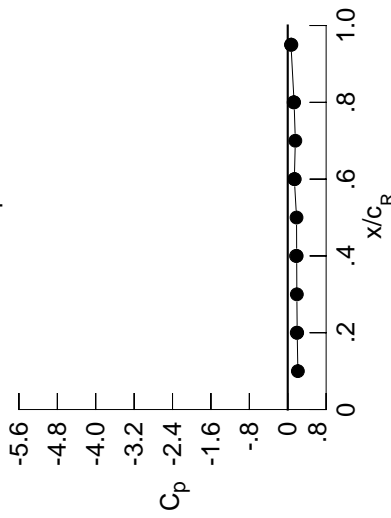

x/c_R	starb'd C_p	port C_p
0.10	0.2112	0.1882
0.20	0.1972	0.1882
0.30	0.1900	0.1882
0.40	0.1865	0.1725
0.50	0.1834	0.1725
0.60	0.1379	0.1460
0.70	0.1583	0.1460
0.80	0.1325	0.1230
0.90	0.0677	0.0760

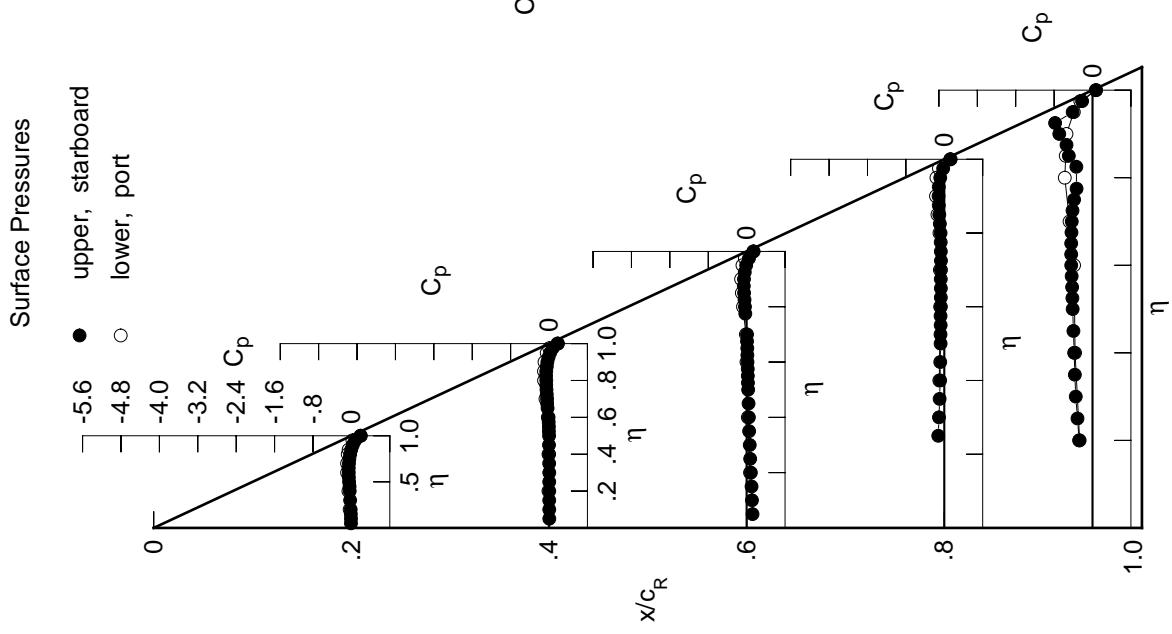

Table F1. Continued.

η	x/c_R	x/c_R	x/c_R	x/c_R	x/c_R	x/c_R	x/c_R	x/c_R	x/c_R
	$C_{p,u}$	$C_{p,u}$	$C_{p,u}$	$C_{p,u}$	$C_{p,u}$	$C_{p,u}$	$C_{p,u}$	$C_{p,u}$	$C_{p,u}$
0.050	-0.0201	-0.0036	0.1167	*****	*****	*****	*****	*****	*****
0.100	-0.0188	-0.0044	0.1063	*****	*****	*****	*****	*****	*****
0.150	-0.0226	-0.0038	0.0946	*****	*****	*****	*****	*****	*****
0.200	-0.0261	-0.0041	0.0801	*****	*****	*****	*****	*****	*****
0.250	*****	-0.0056	0.0672	-0.1309	-0.3075	*****	*****	*****	*****
0.300	-0.0340	-0.0034	0.0593	-0.1155	-0.3421	*****	*****	*****	*****
0.350	*****	-0.0062	0.0462	-0.1046	-0.3612	*****	*****	*****	*****
0.400	-0.0459	-0.0078	0.0381	-0.0930	-0.3761	*****	*****	*****	*****
0.450	-0.0517	-0.0085	0.0351	-0.0904	-0.3888	*****	*****	*****	*****
0.500	-0.0614	-0.0096	0.0235	-0.0844	-0.4047	*****	*****	*****	*****
0.525	*****	-0.0127	0.0193	-0.0846	-0.4117	*****	*****	*****	*****
0.550	-0.0658	-0.0120	0.0150	-0.0829	-0.4167	*****	*****	*****	*****
0.575	*****	-0.0164	0.0154	-0.0818	-0.4272	*****	*****	*****	*****
0.600	-0.0691	-0.0179	0.0091	-0.0784	-0.4343	*****	*****	*****	*****
0.625	*****	*****	0.0061	-0.0806	-0.4384	*****	*****	*****	*****
0.650	-0.0708	-0.0496	0.0058	-0.0802	-0.4389	*****	*****	*****	*****
0.675	*****	-0.0539	-0.0013	-0.0819	-0.4340	*****	*****	*****	*****
0.700	-0.0672	-0.0556	-0.0025	-0.0795	-0.4285	*****	*****	*****	*****
0.725	*****	-0.0631	*****	-0.0794	-0.4169	*****	*****	*****	*****
0.750	-0.0583	-0.0694	*****	-0.0802	-0.3880	*****	*****	*****	*****
0.775	*****	-0.0754	-0.0455	-0.0832	-0.3487	*****	*****	*****	*****
0.800	-0.0458	-0.0781	-0.0503	-0.0892	*****	*****	*****	*****	*****
0.825	*****	-0.0829	-0.0605	-0.1084	-0.3979	*****	*****	*****	*****
0.850	-0.0229	-0.0795	-0.0708	-0.1201	-0.5109	*****	*****	*****	*****
0.875	*****	-0.0710	-0.0810	-0.1323	-0.5404	*****	*****	*****	*****
0.900	0.0081	-0.0578	-0.0811	-0.1411	-0.6547	*****	*****	*****	*****
0.925	*****	-0.0414	-0.0654	-0.1380	-0.6312	*****	*****	*****	*****
0.950	0.0562	-0.0035	-0.0400	-0.1127	-0.4187	*****	*****	*****	*****
0.975	*****	0.0474	0.0152	-0.0551	-0.2348	*****	*****	*****	*****
1.000	0.2003	0.1901	0.1513	0.1452	0.0760	*****	*****	*****	*****
	$C_{p,l}$	$C_{p,l}$	$C_{p,l}$	$C_{p,l}$	$C_{p,l}$	$C_{p,l}$	$C_{p,l}$	$C_{p,l}$	$C_{p,l}$
-0.200	-0.0279	-0.0063	0.0742	*****	-0.2684	*****	*****	*****	*****
-0.400	-0.0527	-0.0040	0.0327	-0.0990	-0.3692	*****	*****	*****	*****
-0.600	-0.0774	-0.0172	0.0044	-0.0834	-0.3974	*****	*****	*****	*****
-0.700	-0.0740	-0.0618	-0.0062	-0.0824	-0.4965	*****	*****	*****	*****
-0.800	-0.0565	-0.0842	-0.0594	-0.0927	-0.6003	*****	*****	*****	*****
-0.850	-0.0368	-0.0851	-0.0824	-0.1263	-0.5828	*****	*****	*****	*****
-0.900	*****	-0.0698	-0.0910	-0.1533	-0.6151	*****	*****	*****	*****
-0.950	0.0446	-0.0182	-0.0559	-0.1324	-0.3916	*****	*****	*****	*****
-0.975	*****	0.0363	-0.0019	-0.0743	-0.2372	*****	*****	*****	*****
-1.000	0.1940	0.1847	0.1607	0.1413	0.0869	*****	*****	*****	*****

Medium Radius L.E.
 Run No. = 5, Point No. = 83
 $C_N = -0.015$, $C_m = 0.0062$
 $\alpha = 0.0^\circ$, $M_\infty = 0.800$
 $R_{mac} = 6.0 \times 10^6$

Leading Edge Pressures

- starboard
- port

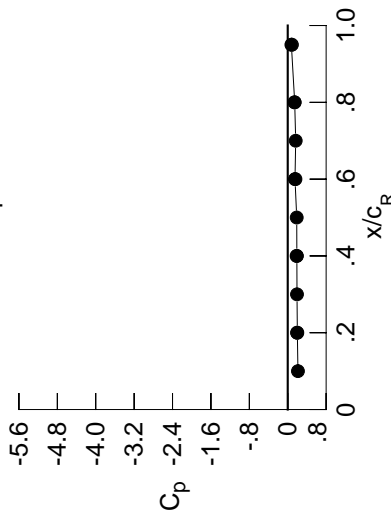

x/c_R	starb'd C_p	port C_p
0.10	0.2127	*****
0.20	0.2003	0.1940
0.30	0.1931	*****
0.40	0.1901	0.1847
0.50	0.1876	*****
0.60	0.1513	0.1607
0.70	0.1660	*****
0.80	0.1452	0.1413
0.90	*****	*****
0.95	0.0760	0.0869

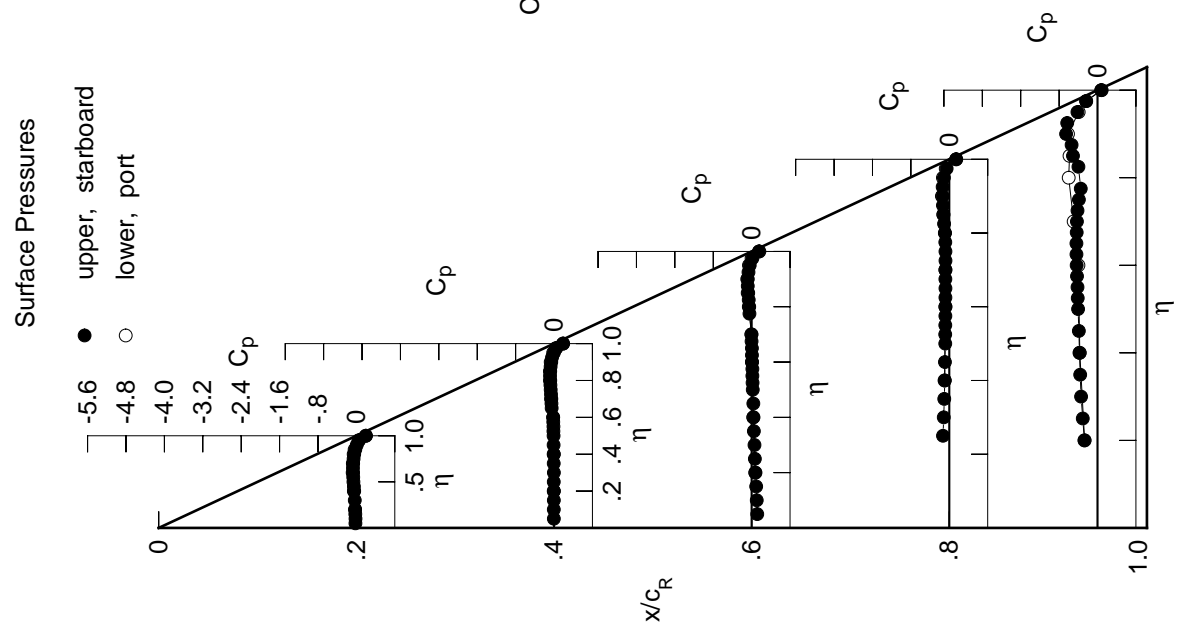

Table F1. Continued.

η	x/c_R .2	$C_{p,u}$	x/c_R .4	$C_{p,u}$	x/c_R .6	$C_{p,u}$	x/c_R .8	$C_{p,u}$	x/c_R .95	$C_{p,u}$
0.050	-0.0390	-0.0200	0.1061	0.1061	0.1061	0.1061	0.1061	0.1061	0.1061	0.1061
0.100	-0.0388	-0.0208	0.0928	0.0928	0.0928	0.0928	0.0928	0.0928	0.0928	0.0928
0.150	-0.0437	-0.0216	0.0826	0.0826	0.0826	0.0826	0.0826	0.0826	0.0826	0.0826
0.200	-0.0446	-0.0210	0.0682	0.0682	0.0682	0.0682	0.0682	0.0682	0.0682	0.0682
0.250	*****	-0.0218	0.0547	-0.1404	-0.2985	-0.2985	-0.2985	-0.2985	-0.2985	-0.2985
0.300	-0.0561	-0.0222	0.0442	-0.1274	-0.3306	-0.3306	-0.3306	-0.3306	-0.3306	-0.3306
0.350	*****	-0.0225	0.0319	-0.1160	-0.3449	-0.3449	-0.3449	-0.3449	-0.3449	-0.3449
0.400	-0.0703	-0.0277	0.0240	-0.1040	-0.3586	-0.3586	-0.3586	-0.3586	-0.3586	-0.3586
0.450	-0.0805	-0.0284	0.0196	-0.1033	-0.3731	-0.3731	-0.3731	-0.3731	-0.3731	-0.3731
0.500	-0.0883	-0.0297	0.0040	-0.0989	-0.3837	-0.3837	-0.3837	-0.3837	-0.3837	-0.3837
0.525	*****	-0.0304	0.0021	-0.0962	-0.3877	-0.3877	-0.3877	-0.3877	-0.3877	-0.3877
0.550	-0.0942	-0.0336	-0.0013	-0.0962	-0.3957	-0.3957	-0.3957	-0.3957	-0.3957	-0.3957
0.575	*****	-0.0328	-0.0014	-0.0970	-0.4060	-0.4060	-0.4060	-0.4060	-0.4060	-0.4060
0.600	-0.0996	-0.0287	-0.0089	-0.0932	-0.4149	-0.4149	-0.4149	-0.4149	-0.4149	-0.4149
0.625	*****	*****	-0.0097	-0.0955	-0.4225	-0.4225	-0.4225	-0.4225	-0.4225	-0.4225
0.650	-0.1029	-0.0878	-0.0145	-0.0963	-0.4254	-0.4254	-0.4254	-0.4254	-0.4254	-0.4254
0.675	*****	-0.0897	-0.0183	-0.0970	-0.4239	-0.4239	-0.4239	-0.4239	-0.4239	-0.4239
0.700	-0.1030	-0.0899	-0.0195	-0.0977	-0.4242	-0.4242	-0.4242	-0.4242	-0.4242	-0.4242
0.725	*****	-0.0948	*****	-0.0963	-0.4166	-0.4166	-0.4166	-0.4166	-0.4166	-0.4166
0.750	-0.0953	-0.1031	*****	-0.1019	-0.3952	-0.3952	-0.3952	-0.3952	-0.3952	-0.3952
0.775	*****	-0.1109	-0.0813	-0.1044	-0.3660	-0.3660	-0.3660	-0.3660	-0.3660	-0.3660
0.800	-0.0862	-0.1197	-0.0964	-0.1003	*****	*****	*****	*****	*****	*****
0.825	*****	-0.1251	-0.1008	-0.1507	-0.4223	-0.4223	-0.4223	-0.4223	-0.4223	-0.4223
0.850	-0.0674	-0.1271	-0.1136	-0.1593	-0.5353	-0.5353	-0.5353	-0.5353	-0.5353	-0.5353
0.875	*****	-0.1234	-0.1268	-0.1725	-0.5561	-0.5561	-0.5561	-0.5561	-0.5561	-0.5561
0.900	-0.0387	-0.1135	-0.1325	-0.1865	-0.6693	-0.6693	-0.6693	-0.6693	-0.6693	-0.6693
0.925	*****	-0.0971	-0.1261	-0.1955	-0.6352	-0.6352	-0.6352	-0.6352	-0.6352	-0.6352
0.950	0.0055	-0.0676	-0.1084	-0.1772	-0.4627	-0.4627	-0.4627	-0.4627	-0.4627	-0.4627
0.975	*****	-0.0231	-0.0596	-0.1328	-0.2963	-0.2963	-0.2963	-0.2963	-0.2963	-0.2963
1.000	0.1856	0.1646	0.1274	0.1149	0.0554	0.0554	0.0554	0.0554	0.0554	0.0554
-0.200	$C_{p,l}$	0.0117	$C_{p,l}$	0.0888	*****	*****	*****	*****	*****	*****
-0.400	-0.0256	0.0171	0.0463	-0.0858	-0.3848	-0.3848	-0.3848	-0.3848	-0.3848	-0.3848
-0.600	-0.0471	-0.0028	0.0238	-0.0688	-0.4231	-0.4231	-0.4231	-0.4231	-0.4231	-0.4231
-0.700	-0.0394	-0.0272	0.0107	-0.0643	-0.5000	-0.5000	-0.5000	-0.5000	-0.5000	-0.5000
-0.800	-0.0173	-0.0476	-0.0256	-0.0668	-0.6355	-0.6355	-0.6355	-0.6355	-0.6355	-0.6355
-0.850	0.0055	-0.0400	-0.0443	-0.0939	-0.6296	-0.6296	-0.6296	-0.6296	-0.6296	-0.6296
-0.900	*****	-0.0179	-0.0419	-0.1097	-0.6778	-0.6778	-0.6778	-0.6778	-0.6778	-0.6778
-0.950	0.0903	0.0384	0.0043	-0.0718	-0.3672	-0.3672	-0.3672	-0.3672	-0.3672	-0.3672
-0.975	*****	0.0955	0.0635	-0.0071	-0.1896	-0.1896	-0.1896	-0.1896	-0.1896	-0.1896
-1.000	0.1873	0.1716	0.1445	0.1288	0.0819	0.0819	0.0819	0.0819	0.0819	0.0819

Medium Radius L.E.
 Run No. = 5, Point No. = 84
 $C_N = 0.029$, $C_m = -0.0020$
 $\alpha = 1.1^\circ$, $M_\infty = 0.799$
 $R_{mac} = 6.0 \times 10^6$

Leading Edge Pressures

- starboard
- port

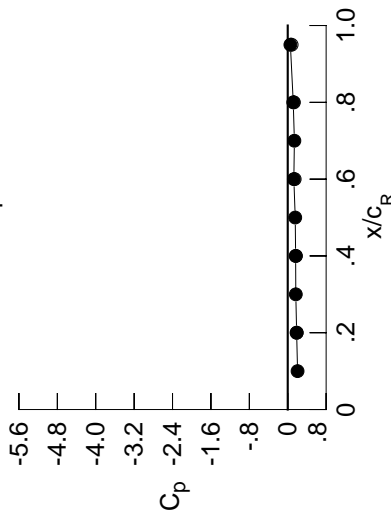

x/c_R	starb'd C_p	port C_p
0.10	0.2050	*****
0.20	0.1856	0.1873
0.30	0.1681	*****
0.40	0.1646	0.1716
0.50	0.1562	*****
0.60	0.1274	0.1445
0.70	0.1387	*****
0.80	0.1149	0.1288
0.90	*****	*****
0.95	0.0554	0.0819

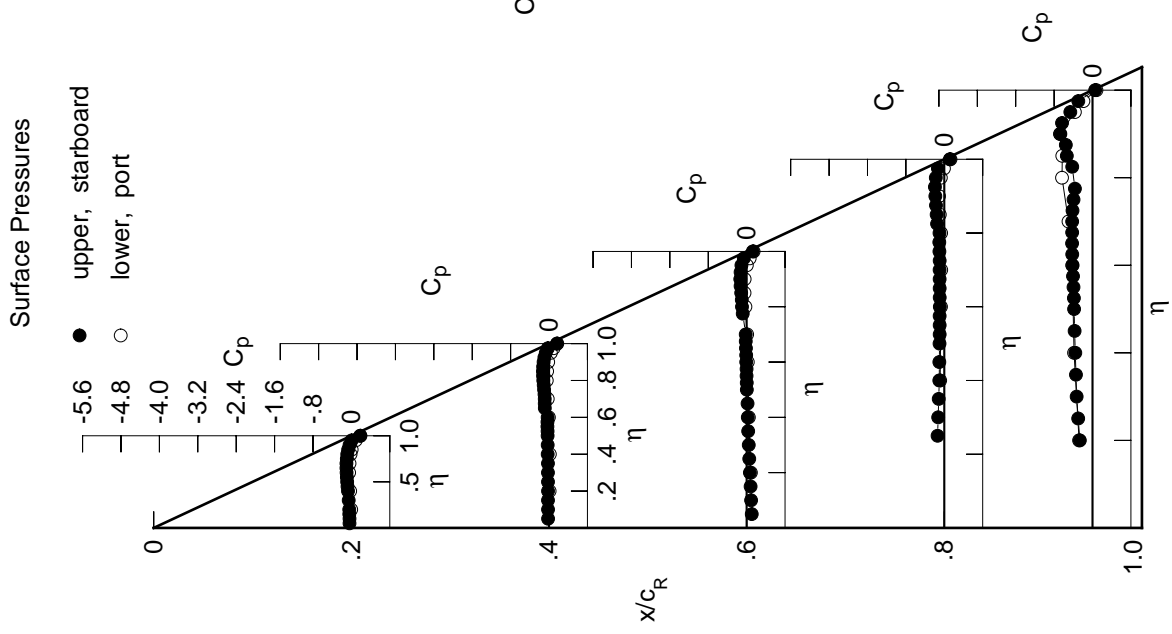
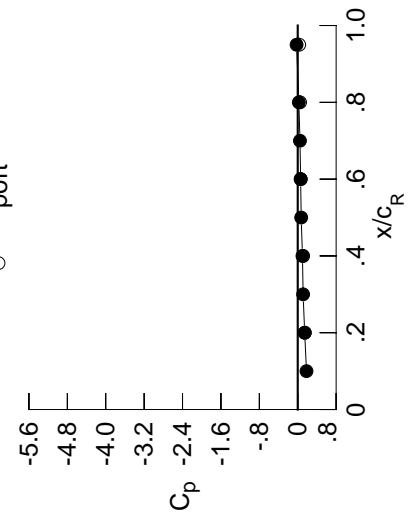

Table F1. Continued.

η	x/c_R	x/c_R	x/c_R	x/c_R	x/c_R	x/c_R	x/c_R
	$C_{p,u}$	$C_{p,u}$	$C_{p,u}$	$C_{p,u}$	$C_{p,u}$	$C_{p,i}$	$C_{p,i}$
0.050	-0.0565	-0.0344	0.0923	*****	*****	0.1000	*****
0.100	-0.0564	-0.0403	0.0813	*****	*****	0.0986	0.1126
0.150	-0.0617	-0.0398	0.0679	*****	*****	0.0720	*****
0.200	-0.0641	-0.0380	0.0553	*****	*****	0.0605	0.0634
0.250	*****	-0.0398	0.0385	-0.1501	-0.2866	0.40	0.0986
0.300	-0.0743	-0.0405	0.0317	-0.1367	-0.3203	0.50	0.0720
0.350	*****	-0.0407	0.0174	-0.1255	-0.3380	0.60	0.0605
0.400	-0.0900	-0.0478	0.0093	-0.1144	-0.3523	0.70	0.0468
0.450	-0.0980	-0.0503	0.0045	-0.1138	-0.3606	0.80	0.0230
0.500	-0.1078	-0.0518	-0.0105	-0.1098	-0.3641	0.90	*****
0.525	*****	-0.0563	-0.0156	-0.1109	-0.3685	0.95	*****
0.550	-0.1155	-0.0618	-0.0194	-0.1101	-0.3699		
0.575	*****	-0.0679	-0.0211	-0.1112	-0.3793		
0.600	-0.1253	-0.0685	-0.0302	-0.1090	-0.3804		
0.625	*****	*****	-0.0329	-0.1105	-0.3835		
0.650	-0.1315	-0.0855	-0.0391	-0.1114	-0.3807		
0.675	*****	-0.0980	-0.0463	-0.1155	-0.3743		
0.700	-0.1354	-0.1059	-0.0513	-0.1177	-0.3718		
0.725	*****	-0.1206	*****	-0.1188	-0.3575		
0.750	-0.1318	-0.1309	*****	-0.1275	-0.3209		
0.775	*****	-0.1450	-0.0889	-0.1329	-0.2641		
0.800	-0.1243	-0.1540	-0.1046	-0.1450	*****		
0.825	*****	-0.1644	-0.1284	-0.1526	-0.2660		
0.850	-0.1100	-0.1677	-0.1499	-0.1823	-0.3178		
0.875	*****	-0.1707	-0.1701	-0.2063	-0.4549		
0.900	-0.0866	-0.1679	-0.1842	-0.2318	-0.7395		
0.925	*****	-0.1572	-0.1837	-0.2480	-1.2822		
0.950	-0.0498	-0.1325	-0.1762	-0.2443	-0.5291		
0.975	*****	-0.1023	-0.1431	-0.2142	-0.3776		
1.000	0.1448	0.0986	0.0605	0.0230	-0.0238		
-0.200	$C_{p,i}$	0.0125	0.0283	0.1000	*****	$C_{p,i}$	0.2898
-0.400		-0.0030	0.0350	0.0595	-0.0768		-0.3972
-0.600		-0.0199	0.0210	0.0390	-0.0554		-0.4351
-0.700		-0.0082	-0.0002	0.0295	-0.0500		-0.4908
-0.800		0.0176	-0.0128	0.0064	-0.0487		-0.6185
-0.850		0.0418	-0.0025	-0.0080	-0.0597		-0.7148
-0.900	*****	0.0256	0.0019	-0.0705	-0.7306		
-0.950		0.1273	0.0841	0.0542	-0.0222		-0.3534
-0.975	*****	0.1386	0.1109	0.0443	-0.1577		
-1.000		0.1477	0.1126	0.0634	0.0488		0.0303

Medium Radius L.E.
 Run No. = 5, Point No. = 85
 $C_N = 0.069$, $C_M = -0.0099$
 $\alpha = 2.1^\circ$, $M_\infty = 0.799$
 $R_{mac} = 6.0 \times 10^6$

Leading Edge Pressures
 ● starboard
 ○ port



x/c_R	starb'd C_p	port C_p
0.10	0.1824	*****
0.20	0.1448	0.1477
0.30	0.1122	*****
0.40	0.0986	0.1126
0.50	0.0720	*****
0.60	0.0605	0.0634
0.70	0.0468	*****
0.80	0.0230	0.0488
0.90	*****	*****
0.95	-0.0238	0.0303

Surface Pressures
 ● upper, starboard
 ○ lower, port

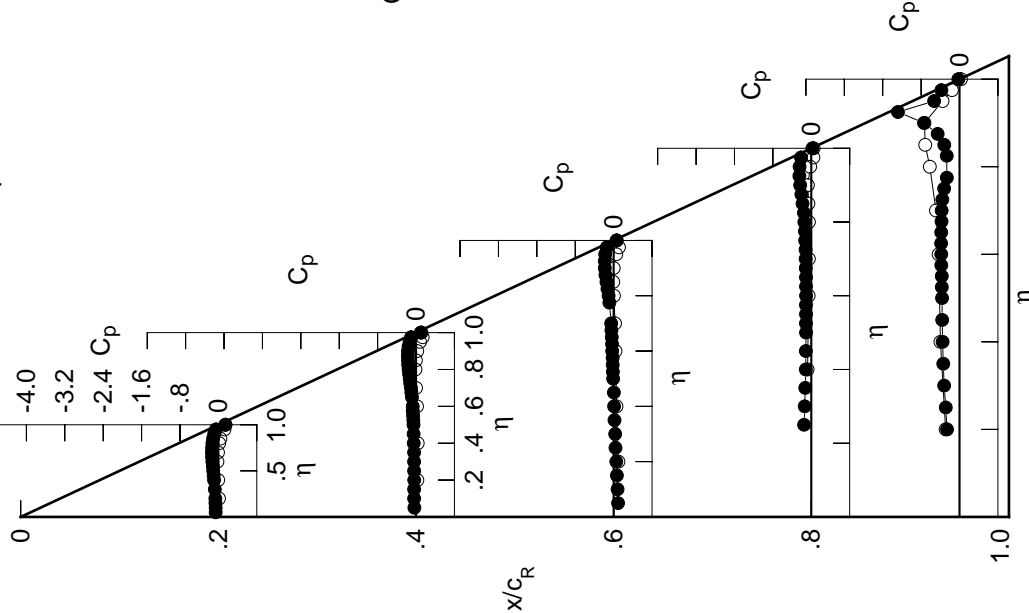

Table F1. Continued.

η	x/c_R	x/c_R	x/c_R	x/c_R	x/c_R	x/c_R	x/c_R
	$C_{p,u}$	$C_{p,u}$	$C_{p,u}$	$C_{p,u}$	$C_{p,u}$	$C_{p,u}$	$C_{p,u}$
0.050	-0.0741	-0.0541	0.0831	0.0831	0.0831	0.0831	0.0831
0.100	-0.0718	-0.0539	0.0706	0.0706	0.0706	0.0706	0.0706
0.150	-0.0771	-0.0558	0.0576	0.0576	0.0576	0.0576	0.0576
0.200	-0.0829	-0.0560	0.0424	0.0424	0.0424	0.0424	0.0424
0.250	*****	-0.0572	0.0290	-0.1596	-0.1596	-0.1596	-0.2606
0.300	-0.0928	-0.0565	0.0171	-0.1438	-0.3034	-0.3034	-0.3034
0.350	*****	-0.0606	0.0049	-0.1356	-0.3181	-0.3181	-0.3181
0.400	-0.1112	-0.0652	-0.0057	-0.1236	-0.3316	-0.3316	-0.3316
0.450	-0.1226	-0.0678	-0.0110	-0.1243	-0.3391	-0.3391	-0.3391
0.500	-0.1323	-0.0732	-0.0252	-0.1205	-0.3427	-0.3427	-0.3427
0.525	*****	-0.0766	-0.0293	-0.1194	-0.3459	-0.3459	-0.3459
0.550	-0.1401	-0.0835	-0.0363	-0.1209	-0.3467	-0.3467	-0.3467
0.575	*****	-0.0873	-0.0373	-0.1218	-0.3541	-0.3541	-0.3541
0.600	-0.1512	-0.0935	-0.0476	-0.1210	-0.3589	-0.3589	-0.3589
0.625	*****	*****	-0.0521	-0.1244	-0.3596	-0.3596	-0.3596
0.650	-0.1612	-0.1099	-0.0582	-0.1281	-0.3593	-0.3593	-0.3593
0.675	*****	-0.1251	-0.0664	-0.1304	-0.3508	-0.3508	-0.3508
0.700	-0.1671	-0.1360	-0.0719	-0.1317	-0.3464	-0.3464	-0.3464
0.725	*****	-0.1487	*****	-0.1371	-0.3286	-0.3286	-0.3286
0.750	-0.1666	-0.1674	*****	-0.1469	-0.2874	-0.2874	-0.2874
0.775	*****	-0.1825	-0.1172	-0.1552	-0.2255	-0.2255	-0.2255
0.800	-0.1629	-0.1963	-0.1393	-0.1673	*****	*****	*****
0.825	*****	-0.2111	-0.1657	-0.1807	-0.2272	-0.2272	-0.2272
0.850	-0.1532	-0.2191	-0.1937	-0.2135	-0.2688	-0.2688	-0.2688
0.875	*****	-0.2266	-0.2196	-0.2460	-0.3922	-0.3922	-0.3922
0.900	-0.1345	-0.2265	-0.2419	-0.2815	-0.6471	-0.6471	-0.6471
0.925	*****	-0.2227	-0.2527	-0.3093	-1.2581	-1.2581	-1.2581
0.950	-0.1113	-0.2065	-0.2584	-0.3206	-0.5706	-0.5706	-0.5706
0.975	*****	-0.1975	-0.2440	-0.3128	-0.4455	-0.4455	-0.4455
1.000	0.0812	-0.0153	-0.0443	-0.1364	-0.1378	-0.1378	-0.1378
$C_{p,i}$	$C_{p,i}$	$C_{p,i}$	$C_{p,i}$	$C_{p,i}$	$C_{p,i}$	$C_{p,i}$	$C_{p,i}$
-0.200	0.0341	0.0482	0.1151	*****	-0.3069	-0.3069	-0.3069
-0.400	0.0215	0.0524	0.0765	-0.0624	-0.4019	-0.4019	-0.4019
-0.600	0.0149	0.0415	0.0583	-0.0398	-0.4531	-0.4531	-0.4531
-0.700	0.0302	0.0287	0.0528	-0.0324	-0.5131	-0.5131	-0.5131
-0.800	0.0585	0.0248	0.0332	-0.0246	-0.6137	-0.6137	-0.6137
-0.850	0.0833	0.0422	0.0299	-0.0340	-0.7027	-0.7027	-0.7027
-0.900	*****	0.0724	0.0448	-0.0274	-0.7658	-0.7658	-0.7658
-0.950	0.1655	0.1286	0.1016	0.0259	-0.3358	-0.3358	-0.3358
-0.975	*****	0.1746	0.1523	0.0904	-0.1318	-0.1318	-0.1318
-1.000	0.0900	0.0094	-0.0821	-0.0976	-0.0835	-0.0835	-0.0835

Medium Radius L.E.
 Run No. = 5, Point No. = 86
 $C_N = 0.111$, $C_m = -0.0190$
 $\alpha = 3.1^\circ$, $M_\infty = 0.799$
 $R_{mac} = 6.0 \times 10^6$

Leading Edge Pressures

- starboard
- port

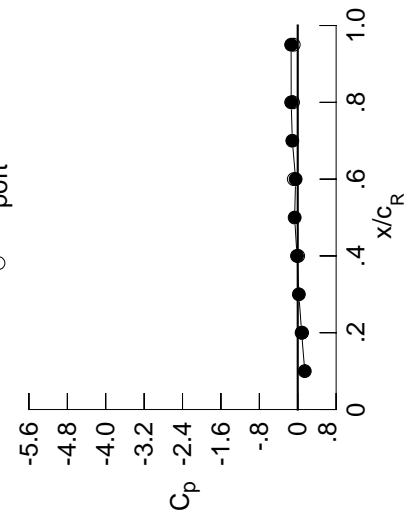

x/c_R	starb'd C_p	port C_p
0.10	0.1463	*****
0.20	0.0812	0.0900
0.30	0.0230	*****
0.40	-0.0153	0.0094
0.50	-0.0644	*****
0.60	-0.0443	-0.0821
0.70	-0.1125	*****
0.80	-0.1364	-0.0976
0.90	*****	*****
0.95	-0.1378	-0.0835

Surface Pressures

- upper, starboard
- lower, port

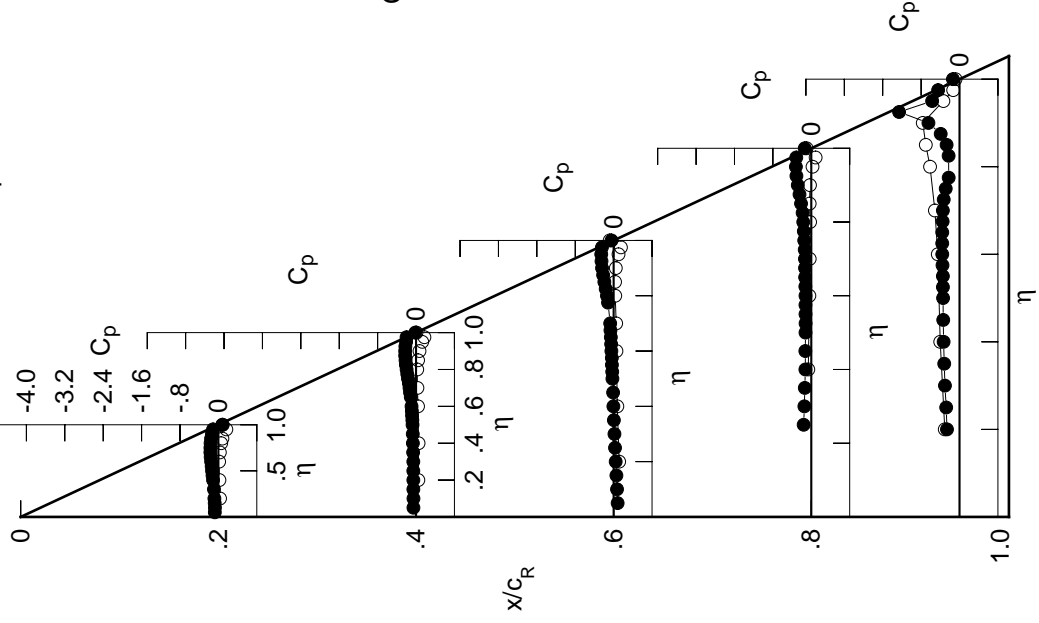
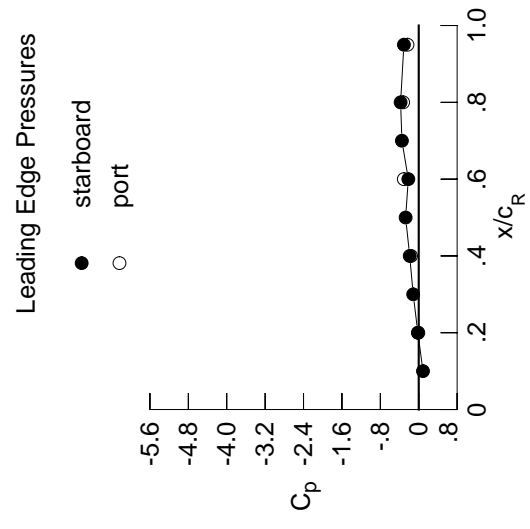

Table F1. Continued.

η	x/c_R	x/c_R	x/c_R	x/c_R	x/c_R	x/c_R	x/c_R
	$C_{p,u}$	$C_{p,u}$	$C_{p,u}$	$C_{p,u}$	$C_{p,u}$	$C_{p,u}$	$C_{p,u}$
0.050	-0.0974	-0.0692	0.0707	*****	*****	*****	*****
0.100	-0.0944	-0.0707	0.0562	*****	*****	*****	*****
0.150	-0.0990	-0.0713	0.0439	*****	*****	*****	*****
0.200	-0.1024	-0.0735	0.0303	*****	*****	*****	-0.2632
0.250	*****	-0.0742	0.0150	-0.1666	-0.2739	*****	*****
0.300	-0.1152	-0.0760	0.0063	-0.1564	-0.2946	*****	*****
0.350	*****	-0.0794	-0.0121	-0.1439	-0.3101	*****	*****
0.400	-0.1370	-0.0855	-0.0205	-0.1352	-0.3229	*****	*****
0.450	-0.1473	-0.0881	-0.0261	-0.1365	-0.3303	*****	*****
0.500	-0.1590	-0.0941	-0.0428	-0.1325	-0.3328	*****	*****
0.525	*****	-0.1013	-0.0477	-0.1323	-0.3362	*****	*****
0.550	-0.1709	-0.1052	-0.0540	-0.1332	-0.3378	*****	*****
0.575	*****	-0.1127	-0.0568	-0.1386	-0.3446	*****	*****
0.600	-0.1848	-0.1166	-0.0687	-0.1359	-0.3470	*****	*****
0.625	*****	*****	-0.0723	-0.1396	-0.3468	*****	*****
0.650	-0.1970	-0.1370	-0.0800	-0.1431	-0.3445	*****	*****
0.675	*****	-0.1545	-0.0889	-0.1499	-0.3367	*****	*****
0.700	-0.2074	-0.1682	-0.0991	-0.1521	-0.3290	*****	*****
0.725	*****	-0.1849	*****	-0.1591	-0.3068	*****	*****
0.750	-0.2109	-0.2058	*****	-0.1674	-0.2607	*****	*****
0.775	*****	-0.2237	-0.1502	-0.1817	-0.1930	*****	*****
0.800	-0.2128	-0.2439	-0.1752	-0.1963	*****	*****	*****
0.825	*****	-0.2622	-0.2067	-0.2119	-0.1977	*****	*****
0.850	-0.2077	-0.2777	-0.2441	-0.2499	-0.2345	*****	*****
0.875	*****	-0.2864	-0.2763	-0.2922	-0.3412	*****	*****
0.900	-0.1967	-0.2984	-0.3127	-0.3367	-0.5831	*****	*****
0.925	*****	-0.3026	-0.3311	-0.3809	-1.1525	*****	*****
0.950	-0.1869	-0.2996	-0.3520	-0.4080	-0.6167	*****	*****
0.975	*****	-0.3132	-0.3684	-0.4348	-0.5314	*****	*****
1.000	-0.0182	-0.1880	-0.2171	-0.3778	-0.3091	*****	*****
-0.200	$C_{p,l}$	0.0651	$C_{p,l}$	0.1283	*****	$C_{p,l}$	-0.3203
-0.400	0.0445	0.0739	0.0908	-0.0509	-0.4277	*****	*****
-0.600	0.0397	0.0625	0.0760	-0.0253	-0.4838	*****	*****
-0.700	0.0562	0.0558	0.0710	-0.0160	-0.5698	*****	*****
-0.800	0.0981	0.0567	0.0600	-0.0038	-0.6385	*****	*****
-0.850	0.1134	0.0747	0.0635	-0.0075	-0.6921	*****	*****
-0.900	*****	0.1058	0.0790	0.0064	-0.7300	*****	*****
-0.950	0.1865	0.1578	0.1341	0.0626	-0.3090	*****	*****
-0.975	*****	0.1926	0.1746	0.1201	-0.1028	*****	*****
-1.000	-0.0086	-0.1592	-0.3113	-0.3249	-0.2339	*****	*****

Medium Radius L.E.
 Run No. = 5, Point No. = 87
 $C_N = 0.149$, $C_m = -0.0221$
 $\alpha = 4.2^\circ$, $M_\infty = 0.800$
 $R_{mac} = 6.0 \times 10^6$



Leading Edge Pressures

x/c_R	starb'd C_p	port C_p
0.10	0.0891	*****
0.20	-0.0182	-0.0086
0.30	-0.1154	*****
0.40	-0.1880	-0.1592
0.50	-0.2731	*****
0.60	-0.2171	-0.3113
0.70	-0.3504	*****
0.80	-0.3778	-0.3249
0.90	*****	*****
0.95	-0.3091	-0.2339

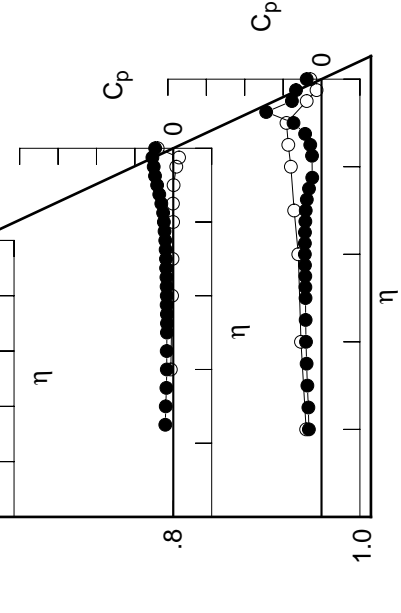
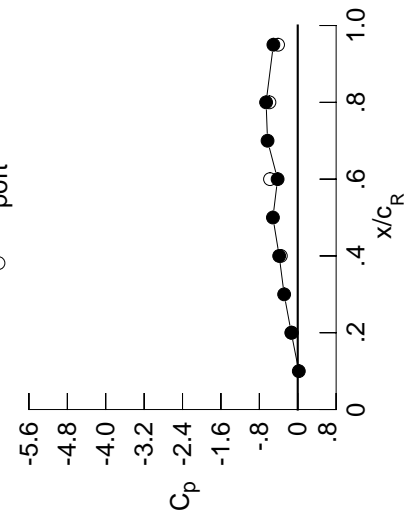

Table F1. Continued.

η	x/c_R	x/c_R	x/c_R	x/c_R	x/c_R	x/c_R	x/c_R
	$C_{p,u}$	$C_{p,u}$	$C_{p,u}$	$C_{p,u}$	$C_{p,u}$	$C_{p,i}$	$C_{p,i}$
0.050	-0.1112	-0.0837	0.0592	0.0592	0.0592	0.1420	0.1420
0.100	-0.1097	-0.0869	0.0470	0.0470	0.0470	0.1094	0.1094
0.150	-0.1138	-0.0860	0.0350	0.0350	0.0350	0.0938	0.0938
0.200	-0.1209	-0.0874	0.0191	0.0191	0.0191	0.0802	0.0802
0.250	*****	-0.0890	0.0043	0.0043	0.0043	0.0870	0.0870
0.300	-0.1345	-0.0936	-0.0087	-0.1617	-0.2841	0.0917	0.0917
0.350	*****	-0.0955	-0.0213	-0.1533	-0.2994	0.0845	0.0845
0.400	-0.1568	-0.1035	-0.0343	-0.1437	-0.3146	0.0906	0.0906
0.450	-0.1686	-0.1075	-0.0386	-0.1431	-0.3257	0.1401	0.1401
0.500	-0.1823	-0.1151	-0.0578	-0.1421	-0.3326	0.1633	0.1633
0.525	*****	-0.1191	-0.0616	-0.1434	-0.3368	0.1894	0.1894
0.550	-0.1957	-0.1275	-0.0704	-0.1444	-0.3392	0.2045	0.2045
0.575	*****	-0.1343	-0.0744	-0.1490	-0.3429	0.1894	0.1894
0.600	-0.2128	-0.1416	-0.0845	-0.1476	-0.3430	0.1633	0.1633
0.625	*****	*****	-0.0901	-0.1543	-0.3427	0.1378	0.1378
0.650	-0.2295	-0.1637	-0.0999	-0.1594	-0.3385	0.1894	0.1894
0.675	*****	-0.1827	-0.1124	-0.1630	-0.3270	0.1633	0.1633
0.700	-0.2427	-0.1969	-0.1216	-0.1702	-0.3170	0.1378	0.1378
0.725	*****	-0.2177	*****	-0.1758	-0.2935	0.1894	0.1894
0.750	-0.2512	-0.2405	*****	-0.1908	-0.2467	0.1633	0.1633
0.775	*****	-0.2621	-0.1811	-0.2026	-0.1816	0.1378	0.1378
0.800	-0.2569	-0.2870	-0.2089	-0.2201	*****	0.1894	0.1894
0.825	*****	-0.3087	-0.2460	-0.2409	-0.1803	0.1633	0.1633
0.850	-0.2588	-0.3324	-0.2882	-0.2834	-0.1991	0.1378	0.1378
0.875	*****	-0.3480	-0.3306	-0.3316	-0.2731	0.1894	0.1894
0.900	-0.2579	-0.3672	-0.3745	-0.3874	-0.4663	0.1633	0.1633
0.925	*****	-0.3806	-0.4098	-0.4460	-0.9030	0.1378	0.1378
0.950	-0.2632	-0.3928	-0.4486	-0.4944	-0.6569	0.1894	0.1894
0.975	*****	-0.4366	-0.4877	-0.5453	-0.6064	0.1633	0.1633
1.000	-0.1344	-0.3862	-0.4195	-0.6589	-0.5072	0.1378	0.1378
-0.200	0.0775	0.0828	0.1094	0.1420	0.1420	0.1420	0.1420
-0.400	0.0679	0.0936	0.1094	0.1094	0.1094	0.1094	0.1094
-0.600	0.0705	0.0834	0.0938	0.0938	0.0938	0.0938	0.0938
-0.700	0.0905	0.0802	0.0917	0.0917	0.0917	0.0917	0.0917
-0.800	0.1225	0.0870	0.0845	0.0845	0.0845	0.0845	0.0845
-0.850	0.1429	0.1097	0.0906	0.0906	0.0906	0.0906	0.0906
-0.900	*****	0.1401	0.1123	0.0344	-0.6960	0.0344	0.0344
-0.950	0.2088	0.1851	0.1633	0.0930	-0.2884	0.0930	0.0930
-0.975	*****	0.2045	0.1894	0.1378	-0.0812	0.1378	0.1378
-1.000	-0.1233	-0.3521	-0.5773	-0.5895	-0.4096	-0.5895	-0.4096

Medium Radius L.E.
 Run No. = 5, Point No. = 88
 $C_N = 0.189$, $C_m = -0.0294$
 $\alpha = 5.2^\circ$, $M_\infty = 0.799$
 $R_{mac} = 6.0 \times 10^6$

Leading Edge Pressures
 ● starboard
 ○ port



x/c_R	starb'd C_p	port C_p
0.10	0.0226	*****
0.20	-0.1344	-0.1233
0.30	-0.2831	*****
0.40	-0.3862	-0.3521
0.50	-0.5168	*****
0.60	-0.4195	-0.5773
0.70	-0.6291	*****
0.80	-0.6589	-0.5895
0.90	*****	*****
0.95	-0.5072	-0.4096

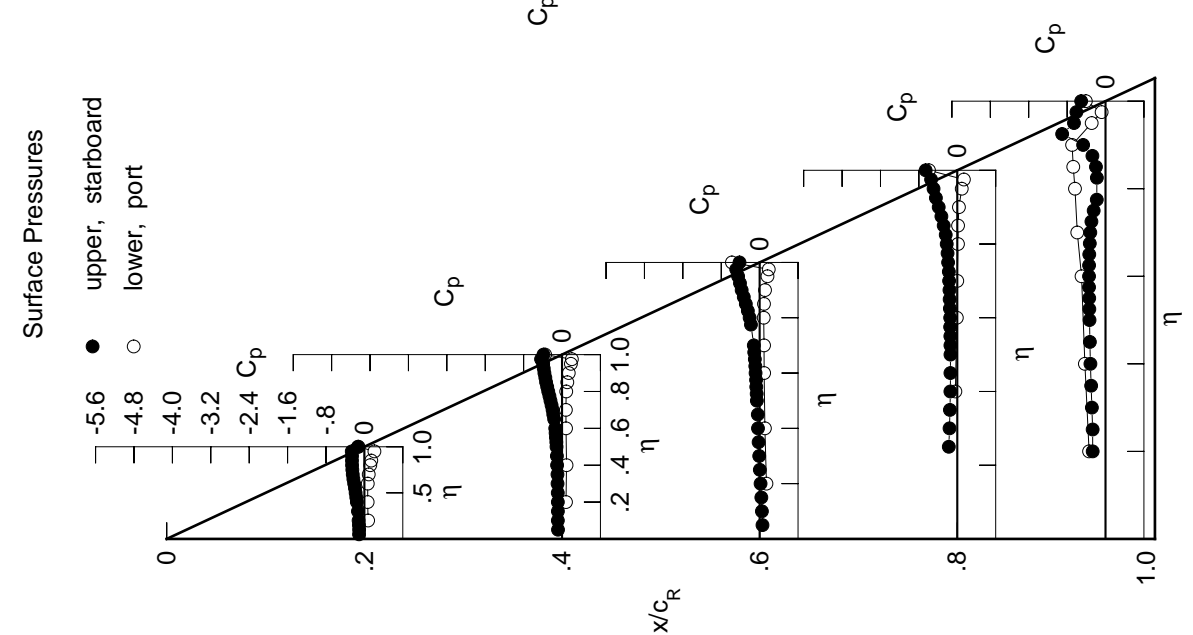

Table F1. Continued.

η	$x/c_R = .2$		$x/c_R = .4$		$x/c_R = .6$		$x/c_R = .8$		$x/c_R = .95$	
	$C_{p,u}$	$C_{p,l}$	$C_{p,u}$	$C_{p,l}$	$C_{p,u}$	$C_{p,l}$	$C_{p,u}$	$C_{p,l}$	$C_{p,u}$	$C_{p,l}$
0.050	-0.1293	-0.0991	0.0472	*****	*****	*****	*****	*****	*****	*****
0.100	-0.1283	-0.0992	0.0380	*****	*****	*****	*****	*****	*****	*****
0.150	-0.1352	-0.1043	0.0197	*****	*****	*****	*****	*****	*****	*****
0.200	-0.1386	-0.1032	0.0094	*****	*****	*****	*****	*****	*****	*****
0.250	*****	-0.1076	-0.0085	-0.1851	-0.2659	*****	*****	*****	*****	*****
0.300	-0.1533	-0.1075	-0.0185	-0.1715	-0.2734	*****	*****	*****	*****	*****
0.350	*****	-0.1146	-0.0351	-0.1614	-0.2896	*****	*****	*****	*****	*****
0.400	-0.1779	-0.1220	-0.0450	-0.1533	-0.3120	*****	*****	*****	*****	*****
0.450	-0.1931	-0.1283	-0.0528	-0.1537	-0.3310	*****	*****	*****	*****	*****
0.500	-0.2075	-0.1327	-0.0713	-0.1531	-0.3436	*****	*****	*****	*****	*****
0.525	*****	-0.1459	-0.0814	-0.1537	-0.3478	*****	*****	*****	*****	*****
0.550	-0.2235	-0.1494	-0.0894	-0.1580	-0.3547	*****	*****	*****	*****	*****
0.575	*****	-0.1611	-0.0945	-0.1633	-0.3604	*****	*****	*****	*****	*****
0.600	-0.2450	-0.1651	-0.1066	-0.1607	-0.3647	*****	*****	*****	*****	*****
0.625	*****	*****	-0.1140	-0.1679	-0.3624	*****	*****	*****	*****	*****
0.650	-0.2634	-0.1925	-0.1237	-0.1743	-0.3640	*****	*****	*****	*****	*****
0.675	*****	-0.2137	-0.1394	-0.1867	-0.3527	*****	*****	*****	*****	*****
0.700	-0.2809	-0.2273	-0.1517	-0.1931	-0.3463	*****	*****	*****	*****	*****
0.725	*****	-0.2532	*****	-0.2037	-0.3242	*****	*****	*****	*****	*****
0.750	-0.2949	-0.2763	*****	-0.2202	-0.2832	*****	*****	*****	*****	*****
0.775	*****	-0.3064	-0.2139	-0.2432	-0.2220	*****	*****	*****	*****	*****
0.800	-0.3073	-0.3323	-0.2463	-0.2575	*****	*****	*****	*****	*****	*****
0.825	*****	-0.3651	-0.2844	-0.2784	-0.2046	*****	*****	*****	*****	*****
0.850	-0.3161	-0.3904	-0.3324	-0.3200	-0.2039	*****	*****	*****	*****	*****
0.875	*****	-0.4207	-0.3851	-0.3671	-0.2382	*****	*****	*****	*****	*****
0.900	-0.3279	-0.4452	-0.4413	-0.4370	-0.3179	*****	*****	*****	*****	*****
0.925	*****	-0.4746	-0.4941	-0.5083	-0.4547	*****	*****	*****	*****	*****
0.950	-0.3532	-0.4936	-0.5567	-0.5904	-0.6274	*****	*****	*****	*****	*****
0.975	*****	-0.5771	-0.6303	-0.6834	-0.6636	*****	*****	*****	*****	*****
1.000	-0.2851	-0.6483	-0.6586	-0.9873	-0.7596	*****	*****	*****	*****	*****
-0.200	0.0998	0.1046	0.1566	*****	-0.3588	*****	*****	*****	*****	*****
-0.400	0.0925	0.1128	0.1218	-0.0268	-0.4404	*****	*****	*****	*****	*****
-0.600	0.0987	0.1064	0.1124	0.0041	-0.5198	*****	*****	*****	*****	*****
-0.700	0.1201	0.1062	0.1108	0.0164	-0.6195	*****	*****	*****	*****	*****
-0.800	0.1522	0.1178	0.1090	0.0352	-0.6382	*****	*****	*****	*****	*****
-0.850	0.1758	0.1403	0.1182	0.0398	-0.6568	*****	*****	*****	*****	*****
-0.900	*****	0.1701	0.1412	0.0621	-0.6631	*****	*****	*****	*****	*****
-0.950	0.2224	0.2048	0.1850	0.1177	-0.2678	*****	*****	*****	*****	*****
-0.975	*****	0.2052	0.1939	0.1490	-0.0649	*****	*****	*****	*****	*****
-1.000	-0.2736	-0.6058	-0.8964	-0.9208	-0.6375	*****	*****	*****	*****	*****

Medium Radius L.E.
 Run No. = 5, Point No. = 89
 $C_N = 0.230$, $C_m = -0.0358$
 $\alpha = 6.3^\circ$, $M_\infty = 0.799$
 $R_{mac} = 6.0 \times 10^6$

Leading Edge Pressures

● starboard
 ○ port

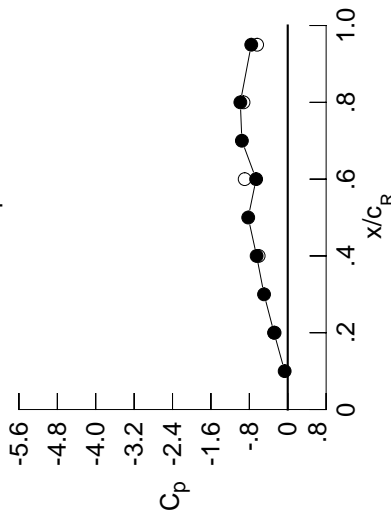

x/c_R	starb'd C_p	port C_p
0.10	-0.0642	*****
0.20	-0.2851	-0.2736
0.30	-0.4937	*****
0.40	-0.6483	-0.6058
0.50	-0.8236	*****
0.60	-0.6586	-0.8964
0.70	-0.9553	*****
0.80	-0.9873	-0.9208
0.90	*****	*****
0.95	-0.7596	-0.6375

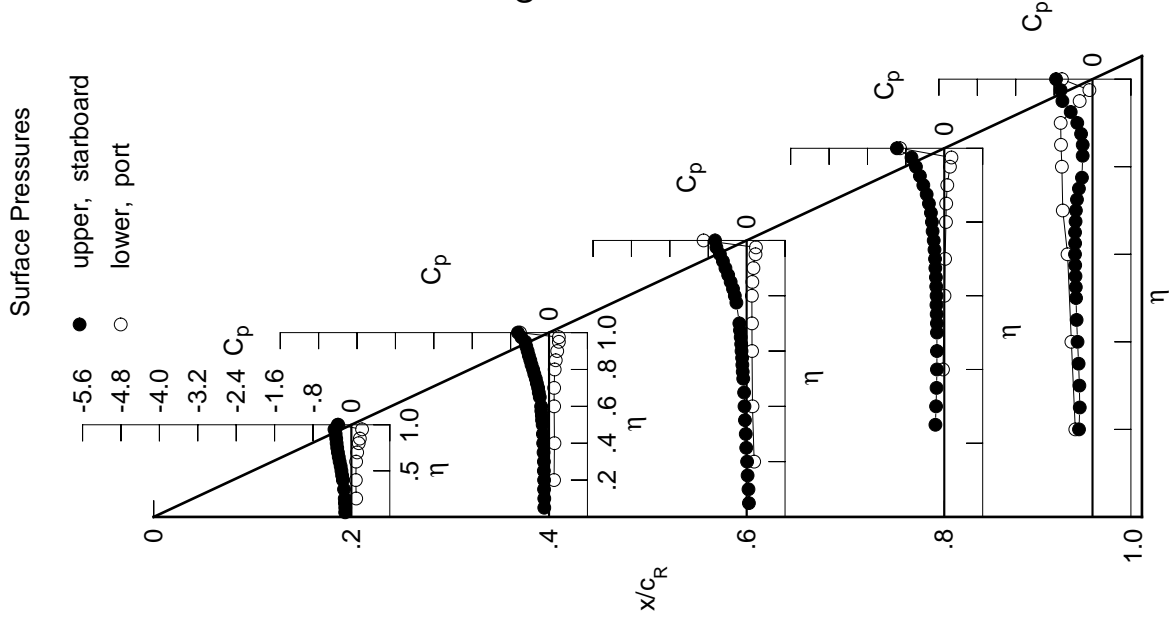
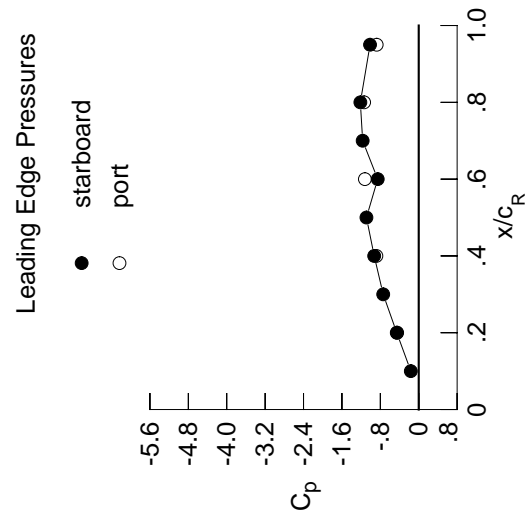

Table F1. Continued.

η	x/c_R	$C_{p,u}$	x/c_R	$C_{p,u}$	x/c_R	$C_{p,u}$	x/c_R	$C_{p,u}$	x/c_R	$C_{p,u}$
0.050	0.2	-0.1458	0.4	-0.1135	0.6	0.0379	0.8	0.0379	0.95	0.0379
0.100		-0.1477		-0.1169		0.0249		0.0249		0.0249
0.150		-0.1526		-0.1204		0.0114		0.0114		0.0114
0.200		-0.1589		-0.1210		-0.0046		-0.0046		-0.0046
0.250		*****		-0.1236		-0.0197		-0.1959		-0.2491
0.300		-0.1757		-0.1263		-0.0333		-0.1822		-0.2695
0.350		*****		-0.1327		-0.0482		-0.1728		-0.2878
0.400		-0.2021		-0.1389		-0.0625		-0.1626		-0.3003
0.450		-0.2154		-0.1502		-0.0694		-0.1655		-0.3169
0.500		-0.2329		-0.1599		-0.0909		-0.1641		-0.3410
0.525		*****		-0.1667		-0.0988		-0.1662		-0.3542
0.550		-0.2514		-0.1779		-0.1079		-0.1674		-0.3713
0.575		*****		-0.1859		-0.1151		-0.1729		-0.3927
0.600		-0.2741		-0.1952		-0.1301		-0.1753		-0.4106
0.625		*****		*****		-0.1427		-0.1832		-0.4264
0.650		-0.3029		-0.2263		-0.1564		-0.1937		-0.4347
0.675		*****		-0.2443		-0.1758		-0.2149		-0.4405
0.700		-0.3205		-0.2635		-0.1932		-0.2430		-0.4589
0.725		*****		-0.2850		*****		-0.2710		-0.4712
0.750		-0.3391		-0.3179		*****		-0.2942		-0.4686
0.775		*****		-0.3442		-0.2599		-0.3194		-0.4564
0.800		-0.3571		-0.3799		-0.2897		-0.3344		*****
0.825		*****		-0.4146		-0.3232		-0.3540		-0.3892
0.850		-0.3738		-0.4502		-0.3717		-0.3749		-0.3651
0.875		*****		-0.4863		-0.4284		-0.4053		-0.3220
0.900		-0.3981		-0.5241		-0.4970		-0.4593		-0.2857
0.925		*****		-0.5653		-0.5640		-0.5389		-0.3055
0.950		-0.4519		-0.6069		-0.6501		-0.6373		-0.4559
0.975		*****		-0.6852		-0.7526		-0.7949		-0.6294
1.000		-0.4576		-0.9276		-0.8546		-1.2163		-1.0141
-0.200		$C_{p,l}$		$C_{p,l}$		$C_{p,l}$		$C_{p,l}$		$C_{p,l}$
-0.400		0.1212		0.1243		0.1729		0.1729		0.1729
-0.600		0.1175		0.1327		0.1408		0.1408		0.1408
-0.700		0.1259		0.1313		0.1300		0.1300		0.1300
-0.800		0.1493		0.1316		0.1333		0.1333		0.1333
-0.850		0.1797		0.1455		0.1336		0.1336		0.1336
-0.900		0.2001		0.1678		0.1436		0.1436		0.1436
-0.950		*****		0.1943		0.1661		0.1661		0.1661
-0.975		0.2298		0.2176		0.2006		0.2006		0.2006
-1.000		0.4496		-0.8827		-1.1214		-1.1380		-0.8761

Medium Radius L.E.
 Run No. = 5, Point No. = 90
 $C_N = 0.276$, $C_M = -0.0441$
 $\alpha = 7.3^\circ$, $M_\infty = 0.799$
 $R_{mac} = 6.0 \times 10^6$



Leading Edge Pressures

x/c_R	starb'd C_p	port C_p
0.10	-0.1646	*****
0.20	-0.4576	-0.4496
0.30	-0.7403	*****
0.40	-0.9276	-0.8827
0.50	-1.0892	*****
0.60	-0.8546	-1.1214
0.70	-1.1681	*****
0.80	-1.2163	-1.1380
0.90	*****	*****
0.95	-1.0141	-0.8761

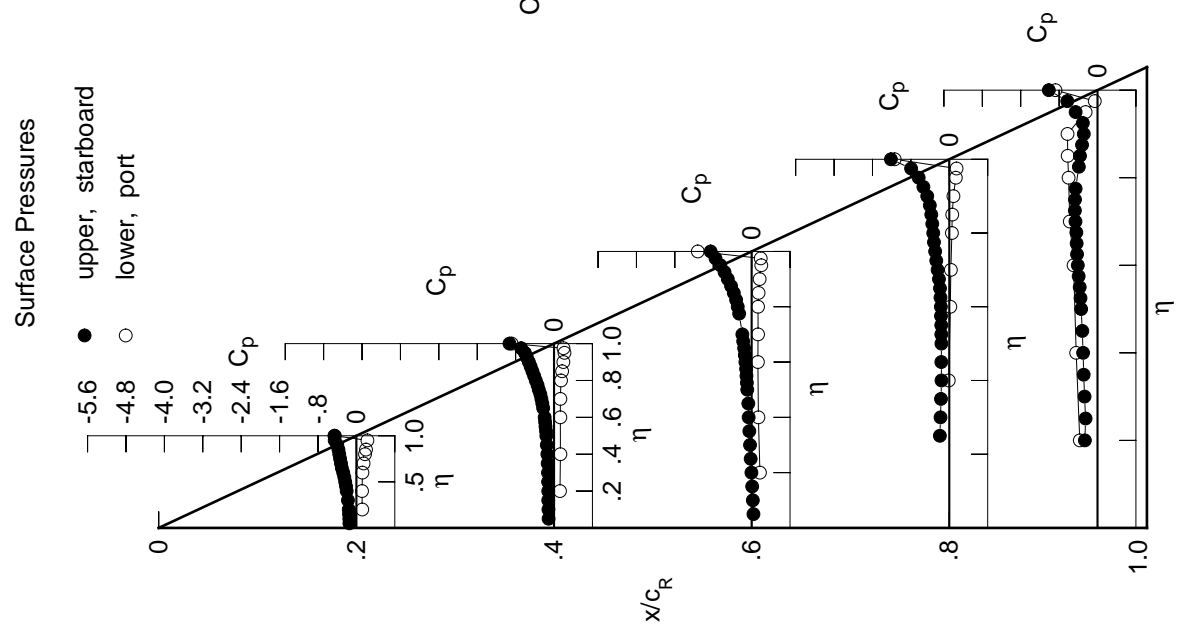
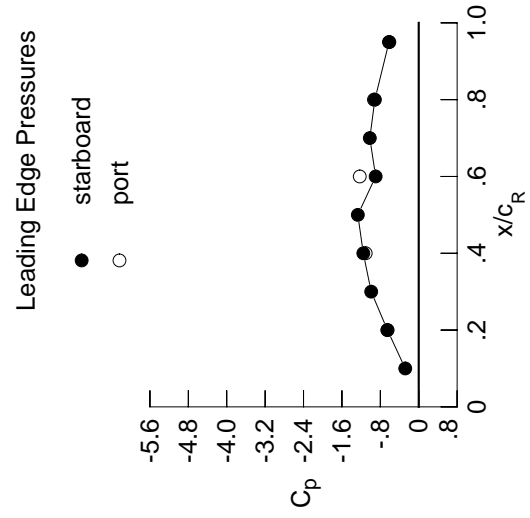

Table F1. Continued.

η	x/c_R .2	x/c_R .4	x/c_R .6	x/c_R .8	x/c_R .95
	$C_{p,u}$	$C_{p,u}$	$C_{p,u}$	$C_{p,u}$	$C_{p,u}$
0.050	-0.1622	-0.1289	0.0255	*****	*****
0.100	-0.1640	-0.1345	0.0103	*****	*****
0.150	-0.1675	-0.1358	-0.0027	*****	*****
0.200	-0.1758	-0.1383	-0.0219	*****	-0.2562
0.250	*****	-0.1403	-0.0334	-0.2119	-0.2444
0.300	-0.1925	-0.1472	-0.0515	-0.1987	-0.2647
0.350	*****	-0.1511	-0.0651	-0.1901	-0.2809
0.400	-0.2219	-0.1634	-0.0797	-0.1801	-0.3034
0.450	-0.2376	-0.1719	-0.0891	-0.1829	-0.3356
0.500	-0.2580	-0.1861	-0.1098	-0.1773	-0.3507
0.525	*****	-0.1965	-0.1184	-0.1811	-0.3411
0.550	-0.2784	-0.2053	-0.1353	-0.1858	-0.3055
0.575	*****	-0.2158	-0.1409	-0.2042	-0.2221
0.600	-0.3042	-0.2292	-0.1662	-0.2284	-0.1823
0.625	*****	*****	-0.1884	-0.2603	-0.2153
0.650	-0.3345	-0.2610	-0.2152	-0.2949	-0.2610
0.675	*****	-0.2822	-0.2392	-0.2295	-0.3110
0.700	-0.3611	-0.3022	-0.2611	-0.2259	-0.3634
0.725	*****	-0.3223	*****	-0.2186	-0.3956
0.750	-0.3851	-0.3538	*****	-0.2233	-0.4058
0.775	*****	-0.3854	-0.3104	-0.2142	-0.4818
0.800	-0.4114	-0.4270	-0.3275	-0.2197	*****
0.825	*****	-0.4630	-0.3514	-0.5113	-0.9383
0.850	-0.4397	-0.5085	-0.3954	-0.8051	-0.9025
0.875	*****	-0.5518	-0.4640	-0.8502	-0.8199
0.900	-0.4647	-0.6012	-0.6236	-0.8498	-0.7271
0.925	*****	-0.6577	-0.8308	-0.8123	-0.6802
0.950	-0.5396	-0.7097	-0.9760	-0.7725	-0.5907
0.975	*****	-0.8473	-1.0180	-0.7679	-0.5735
1.000	-0.6517	-1.1547	-0.8975	-0.9138	-0.6194
	$C_{p,l}$	$C_{p,l}$	$C_{p,l}$	$C_{p,l}$	$C_{p,l}$
-0.200	0.1463	0.1457	0.1914	*****	-0.3793
-0.400	0.1421	0.1582	0.1577	0.0060	-0.4518
-0.600	0.1540	0.1541	0.1531	0.0372	-0.5349
-0.700	0.1766	0.1582	0.1544	0.0517	-0.5721
-0.800	0.2060	0.1741	0.1585	0.0749	-0.5407
-0.850	0.2247	0.1955	0.1712	0.0832	-0.5570
-0.900	*****	0.2181	0.1922	0.1105	-0.5667
-0.950	0.2334	0.2267	0.2162	0.1533	-0.2232
-0.975	*****	0.1835	0.1874	0.1592	-0.0434
-1.000	-0.6511	-1.1049	-1.2289	-0.9330	-0.6121

Medium Radius L.E.
 Run No. = 5, Point No. = 91
 $C_N = 0.334$, $C_m = -0.0574$
 $\alpha = 8.3^\circ$, $M_\infty = 0.799$
 $R_{mac} = 6.0 \times 10^6$



x/c_R	starbd C_p	port C_p
0.10	-0.2809	*****
0.20	-0.6517	-0.6511
0.30	-0.9906	*****
0.40	-1.1547	-1.1049
0.50	-1.2687	*****
0.60	-0.8975	-1.2289
0.70	-1.0191	*****
0.80	-0.9138	-0.9330
0.90	*****	*****
0.95	-0.6194	-0.6121

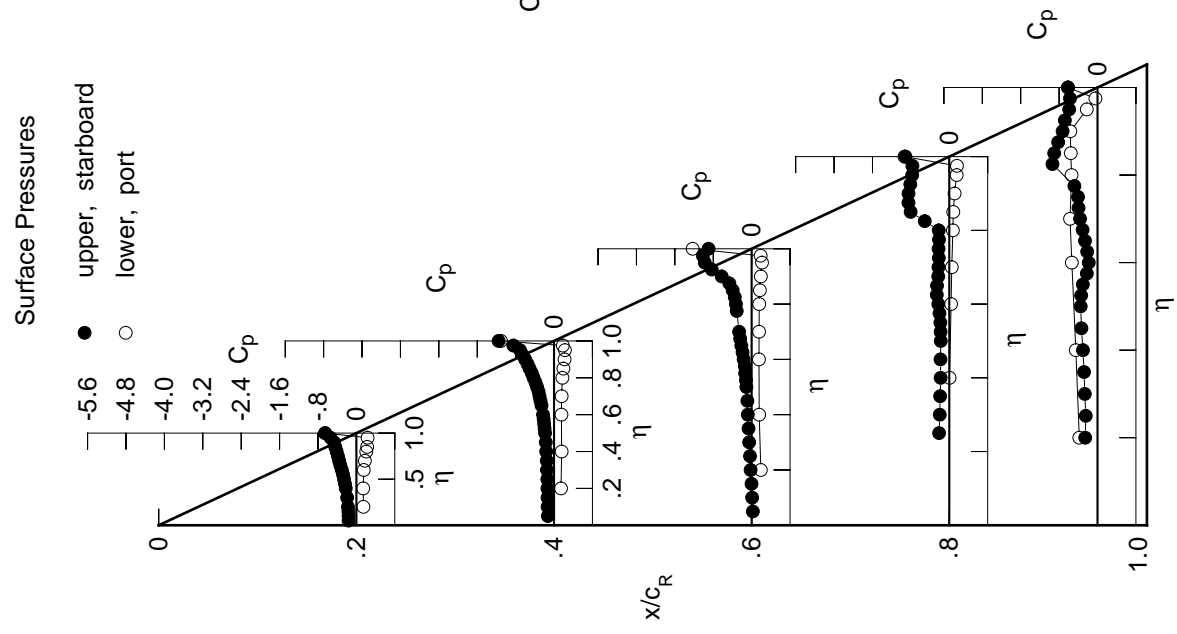
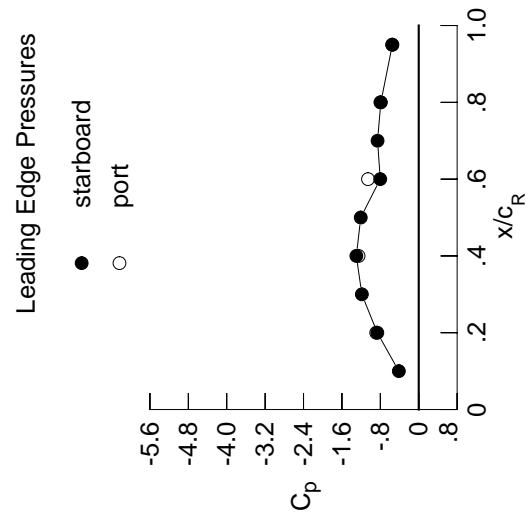

Table F1. Continued.

η	x/c_R .2	x/c_R .4	x/c_R .6	x/c_R .8	x/c_R .95
	$C_{p,u}$	$C_{p,u}$	$C_{p,u}$	$C_{p,u}$	$C_{p,u}$
0.050	-0.1789	-0.1521	0.0054	*****	*****
0.100	-0.1835	-0.1553	-0.0079	*****	*****
0.150	-0.1903	-0.1598	-0.0237	*****	*****
0.200	-0.1977	-0.1606	-0.0381	*****	-0.2993
0.250	*****	-0.1636	-0.0555	-0.2313	-0.2607
0.300	-0.2146	-0.1702	-0.0700	-0.2145	-0.2474
0.350	*****	-0.1771	-0.0860	-0.2061	-0.2672
0.400	-0.2465	-0.1898	-0.0958	-0.1897	-0.3044
0.450	-0.2638	-0.2031	-0.1034	-0.2030	-0.2443
0.500	-0.2854	-0.2200	-0.1341	-0.2375	-0.1873
0.525	*****	-0.2341	-0.1576	-0.2238	-0.2351
0.550	-0.3077	-0.2517	-0.1936	-0.2101	-0.2839
0.575	*****	-0.2669	-0.2191	-0.2046	-0.3457
0.600	-0.3391	-0.2801	-0.2367	-0.2000	-0.3890
0.625	*****	*****	-0.2225	-0.1980	-0.4167
0.650	-0.3719	-0.3167	-0.2156	-0.1950	-0.4244
0.675	*****	-0.3365	-0.2123	-0.1891	-0.4110
0.700	-0.4022	-0.3521	-0.2106	-0.1770	-0.4285
0.725	*****	-0.3731	*****	-0.1690	-0.5303
0.750	-0.4335	-0.4021	*****	-0.2692	-0.7284
0.775	*****	-0.4322	-0.2073	-0.6238	-0.8397
0.800	-0.4677	-0.4691	-0.3281	-0.9080	*****
0.825	*****	-0.5109	-0.7641	-0.9903	-0.7044
0.850	-0.5082	-0.5600	-0.9592	-0.9315	-0.5965
0.875	*****	-0.6115	-1.0022	-0.8081	-0.5792
0.900	-0.5511	-0.6873	-0.9853	-0.7388	-0.5970
0.925	*****	-0.8160	-0.9355	-0.7175	-0.6434
0.950	-0.6224	-1.0054	-0.9039	-0.7175	-0.5748
0.975	*****	-1.2087	-0.8871	-0.6941	-0.5191
1.000	-0.8629	-1.2996	-0.8015	-0.7895	-0.5490
	$C_{p,l}$	$C_{p,l}$	$C_{p,l}$	$C_{p,l}$	$C_{p,l}$
-0.200	0.1703	0.1703	0.2080	*****	-0.3927
-0.400	0.1683	0.1798	0.1762	0.0181	-0.4885
-0.600	0.1815	0.1793	0.1705	0.0545	-0.5393
-0.700	0.2054	0.1843	0.1777	0.0669	-0.5374
-0.800	0.2329	0.2015	0.1810	0.0937	-0.5224
-0.850	0.2466	0.2218	0.1929	0.1028	-0.5397
-0.900	*****	0.2396	0.2124	0.1279	-0.5424
-0.950	0.2319	0.2341	0.2257	0.1646	-0.2080
-0.975	*****	0.1700	0.1842	0.1587	-0.0353
-1.000	-0.8857	-1.2537	-1.0571	-0.7983	-0.5533

Medium Radius L.E.
 Run No. = 5, Point No. = 92
 $C_N = 0.393$, $C_m = -0.0701$
 $\alpha = 9.3^\circ$, $M_\infty = 0.799$
 $R_{mac} = 5.9 \times 10^6$



x/c_R	starb'd C_p	port C_p
0.10	-0.4145	*****
0.20	-0.8629	-0.8857
0.30	-1.1851	*****
0.40	-1.2996	-1.2537
0.50	-1.2082	*****
0.60	-0.8015	-1.0571
0.70	-0.8580	*****
0.80	-0.7895	-0.7983
0.90	*****	*****
0.95	-0.5490	-0.5533

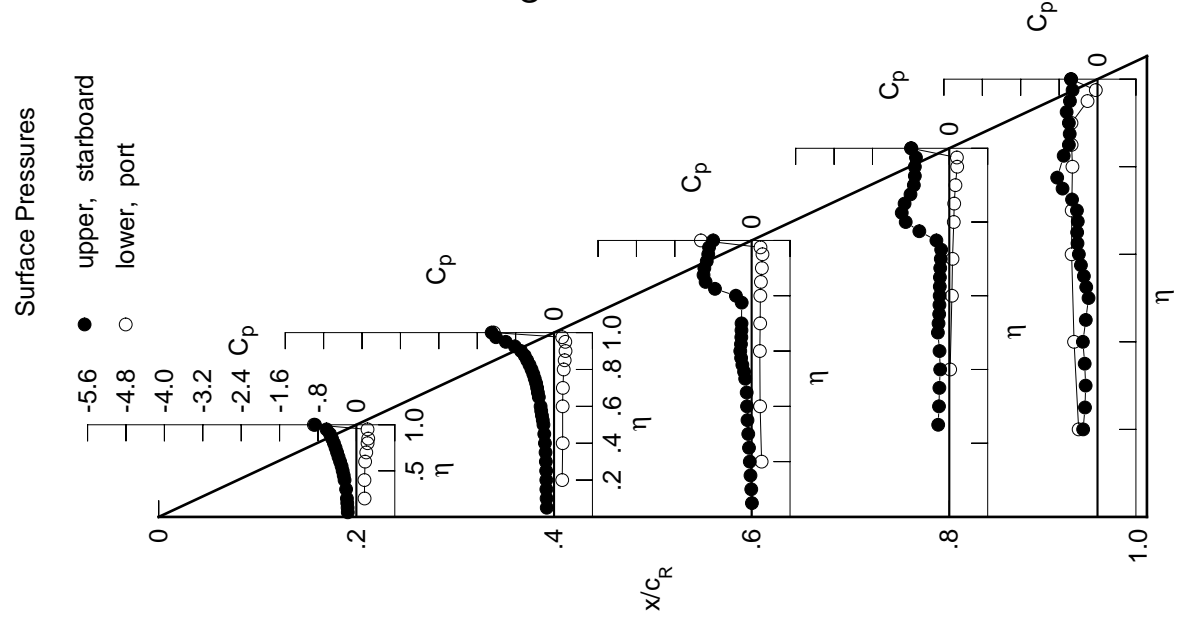
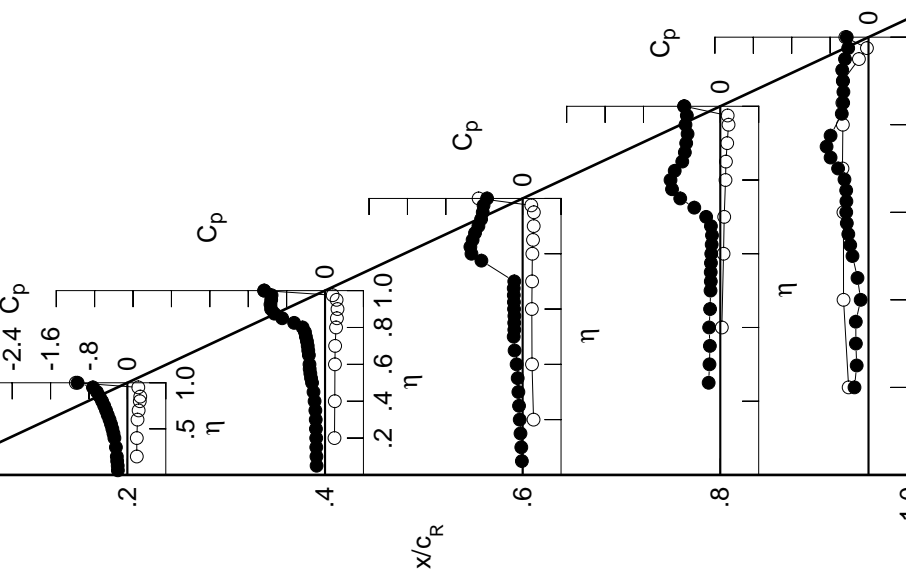
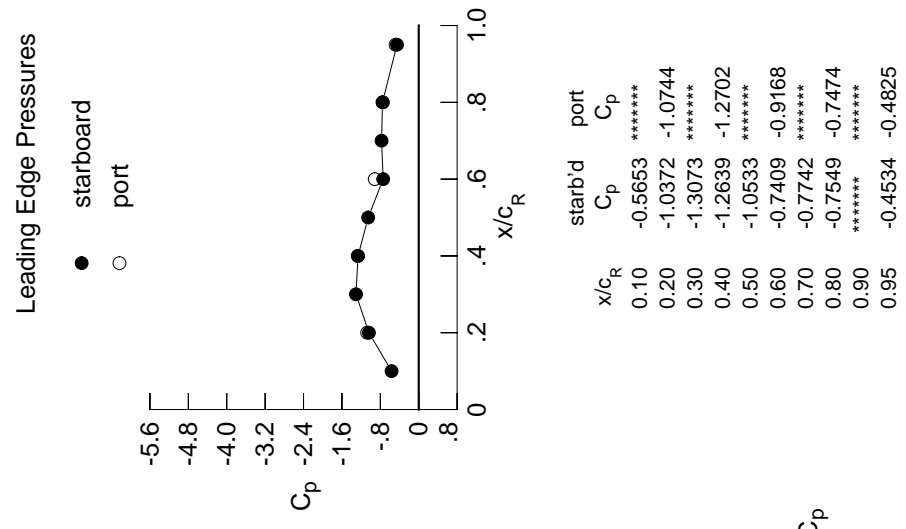

Table F1. Continued.

η	x/c_R	x/c_R	x/c_R	x/c_R	x/c_R	x/c_R	x/c_R	x/c_R	x/c_R
	$C_{p,u}$	$C_{p,u}$	$C_{p,u}$	$C_{p,u}$	$C_{p,u}$	$C_{p,u}$	$C_{p,i}$	$C_{p,i}$	$C_{p,i}$
0.050	-0.1980	-0.1760	-0.0160	*****	*****	*****	*****	*****	*****
0.100	-0.2018	-0.1793	-0.0281	*****	*****	*****	*****	*****	*****
0.150	-0.2125	-0.1827	-0.0444	*****	*****	*****	*****	*****	*****
0.200	-0.2198	-0.1836	-0.0606	*****	*****	*****	*****	*****	*****
0.250	*****	-0.1892	-0.0750	-0.2423	-0.2463	-0.2920	*****	*****	*****
0.300	-0.2388	-0.1940	-0.0891	-0.2246	-0.2633	-0.2646	*****	*****	*****
0.350	*****	-0.2015	-0.1028	-0.2167	-0.2646	-0.1632	*****	*****	*****
0.400	-0.2702	-0.2174	-0.1259	-0.2319	-0.1632	-0.3810	*****	*****	*****
0.450	-0.2907	-0.2402	-0.1681	-0.2125	-0.2295	-0.3332	*****	*****	*****
0.500	-0.3133	-0.2705	-0.1863	-0.2030	-0.3332	-0.3810	*****	*****	*****
0.525	*****	-0.2913	-0.1740	-0.1979	-0.3810	-0.4205	*****	*****	*****
0.550	-0.3405	-0.3066	-0.1754	-0.1989	-0.4205	-0.4520	*****	*****	*****
0.575	*****	-0.3197	-0.1717	-0.1947	-0.4520	-0.4637	*****	*****	*****
0.600	-0.3719	-0.3238	-0.1793	-0.1882	-0.4637	-0.4612	*****	*****	*****
0.625	*****	*****	-0.1818	-0.1789	-0.4612	-0.4650	*****	*****	*****
0.650	-0.4097	-0.3366	-0.1840	-0.1725	-0.4650	-0.5005	*****	*****	*****
0.675	*****	-0.3500	-0.1859	-0.1951	-0.5005	-0.6332	*****	*****	*****
0.700	-0.4452	-0.3605	-0.1745	-0.2941	-0.6332	-0.7907	*****	*****	*****
0.725	*****	-0.3766	*****	-0.5420	-0.7907	-0.8734	*****	*****	*****
0.750	-0.4831	-0.3992	*****	-0.8347	-0.8734	-0.7902	*****	*****	*****
0.775	*****	-0.4184	-0.8591	-1.0052	-0.7902	*****	*****	*****	*****
0.800	-0.5275	-0.4664	-1.0668	-1.0372	*****	-0.5570	*****	*****	*****
0.825	*****	-0.6439	-1.0888	-0.9493	-0.5570	-0.5283	*****	*****	*****
0.850	-0.5772	-0.8929	-1.0424	-0.7924	-0.5283	-0.5234	*****	*****	*****
0.875	*****	-1.0544	-0.9920	-0.7387	-0.5234	-0.5310	*****	*****	*****
0.900	-0.6347	-1.1237	-0.9212	-0.7106	-0.5310	-0.5482	*****	*****	*****
0.925	*****	-1.1366	-0.8654	-0.6814	-0.5482	-0.4895	*****	*****	*****
0.950	-0.7177	-1.1217	-0.8312	-0.7249	-0.4895	-0.4236	*****	*****	*****
0.975	*****	-1.1143	-0.8143	-0.6966	-0.4236	-0.4534	*****	*****	*****
1.000	-1.0372	-1.2639	-0.7409	-0.7549	-0.4534	*****	*****	*****	*****
-0.200	$C_{p,i}$	$C_{p,i}$	$C_{p,i}$	$C_{p,i}$	$C_{p,i}$	$C_{p,i}$	$C_{p,i}$	$C_{p,i}$	$C_{p,i}$
-0.400	0.1957	0.1967	0.2272	*****	*****	-0.4140	*****	*****	*****
-0.600	0.1962	0.2029	0.1951	0.0324	-0.5202	-0.5202	*****	*****	*****
-0.700	0.2112	0.2065	0.1914	0.0677	-0.5225	-0.5225	*****	*****	*****
-0.800	0.2343	0.2103	0.1965	0.0816	-0.5427	-0.5427	*****	*****	*****
-0.850	0.2587	0.2297	0.2020	0.1091	-0.5341	-0.5341	*****	*****	*****
-0.900	0.2676	0.2475	0.2156	0.1178	-0.5450	-0.5450	*****	*****	*****
-0.950	*****	0.2602	0.2302	0.1439	-0.5354	-0.5354	*****	*****	*****
-0.975	0.2276	0.2406	0.2339	0.1722	-0.1999	-0.1999	*****	*****	*****
-1.000	*****	0.1587	0.1799	0.1540	-0.0330	-0.0330	*****	*****	*****
	-1.0744	-1.2702	-0.9168	-0.7474	-0.4825	-0.4825	*****	*****	*****

Medium Radius L.E.
 Run No. = 5, Point No. = 93
 $C_N = 0.445$, $C_M = -0.0765$
 $\alpha = 10.3^\circ$, $M_\infty = 0.799$
 $R_{mac} = 5.9 \times 10^6$



x/c_R	starb'd C_p	port C_p
0.10	-0.5653	*****
0.20	-1.0372	-1.0744
0.30	-1.3073	*****
0.40	-1.2639	-1.2702
0.50	-1.0533	*****
0.60	-0.7409	-0.9168
0.70	-0.7742	*****
0.80	-0.7549	-0.7474
0.90	*****	*****
0.95	-0.4534	-0.4825

Table F1. Continued.

η	x/c_R	x/c_R	x/c_R	x/c_R	x/c_R	x/c_R	x/c_R	x/c_R	x/c_R
	$C_{p,u}$	$C_{p,u}$	$C_{p,u}$	$C_{p,u}$	$C_{p,u}$	$C_{p,u}$	$C_{p,u}$	$C_{p,i}$	$C_{p,i}$
0.050	-0.2187	-0.2012	-0.0372	*****	*****	*****	*****	-0.4129	*****
0.100	-0.2246	-0.2029	-0.0485	*****	*****	*****	*****	-0.5245	*****
0.150	-0.2336	-0.2064	-0.0682	*****	*****	*****	*****	-0.5556	*****
0.200	-0.2426	-0.2119	-0.0819	*****	*****	*****	*****	-0.5914	*****
0.250	*****	-0.2158	-0.0999	-0.2577	-0.2804	*****	*****	-0.5557	*****
0.300	-0.2672	-0.2193	-0.1122	-0.2433	-0.2617	*****	*****	-0.5316	*****
0.350	*****	-0.2258	-0.1503	-0.2509	-0.1614	*****	*****	-0.5544	*****
0.400	-0.3044	-0.2556	-0.1762	-0.2210	-0.2213	*****	*****	-0.5316	*****
0.450	-0.3219	-0.3052	-0.1584	-0.2187	-0.3166	*****	*****	-0.5347	*****
0.500	-0.3468	-0.3151	-0.1686	-0.2084	-0.4097	*****	*****	-0.5347	*****
0.525	*****	-0.3056	-0.1736	-0.2036	-0.4450	*****	*****	-0.5347	*****
0.550	-0.3751	-0.3029	-0.1779	-0.2010	-0.4642	*****	*****	-0.5347	*****
0.575	*****	-0.3032	-0.1758	-0.1962	-0.4847	*****	*****	-0.5347	*****
0.600	-0.4095	-0.3003	-0.1808	-0.1924	-0.4914	*****	*****	-0.5347	*****
0.625	*****	*****	-0.1745	-0.2058	-0.5229	*****	*****	-0.5347	*****
0.650	-0.4503	-0.3108	-0.1763	-0.2623	-0.5980	*****	*****	-0.5347	*****
0.675	*****	-0.3214	-0.2074	-0.4140	-0.7176	*****	*****	-0.5347	*****
0.700	-0.4903	-0.3141	-0.3473	-0.6613	-0.8758	*****	*****	-0.5347	*****
0.725	*****	-0.2975	*****	-0.9227	-0.9799	*****	*****	-0.5347	*****
0.750	-0.5346	-0.3995	*****	-1.0966	-0.8511	*****	*****	-0.5347	*****
0.775	*****	-0.8707	-1.1759	-1.1372	-0.6202	*****	*****	-0.5347	*****
0.800	-0.5858	-1.1246	-1.1955	-0.9492	*****	*****	*****	-0.5347	*****
0.825	*****	-1.1982	-1.1634	-0.8015	-0.5327	*****	*****	-0.5347	*****
0.850	-0.6444	-1.1936	-1.0710	-0.7720	-0.5153	*****	*****	-0.5347	*****
0.875	*****	-1.1728	-0.9496	-0.7700	-0.5154	*****	*****	-0.5347	*****
0.900	-0.7095	-1.1371	-0.8945	-0.7286	-0.5016	*****	*****	-0.5347	*****
0.925	*****	-1.1015	-0.8440	-0.7044	-0.4863	*****	*****	-0.5347	*****
0.950	-0.9708	-1.0771	-0.8015	-0.7289	-0.4260	*****	*****	-0.5347	*****
0.975	*****	-1.0677	-0.7819	-0.7030	-0.3730	*****	*****	-0.5347	*****
1.000	-1.1661	-1.1525	-0.7122	-0.7342	-0.3928	*****	*****	-0.5347	*****
-0.200	0.2232	0.2144	0.2435	*****	-0.4129	*****	*****	-0.5347	*****
-0.400	0.2236	0.2251	0.2133	0.0470	-0.5245	*****	*****	-0.5347	*****
-0.600	0.2395	0.2279	0.2062	0.0800	-0.5556	*****	*****	-0.5347	*****
-0.700	0.2612	0.2348	0.2151	0.0949	-0.5914	*****	*****	-0.5347	*****
-0.800	0.2812	0.2517	0.2212	0.1232	-0.5557	*****	*****	-0.5347	*****
-0.850	0.2872	0.2675	0.2328	0.1323	-0.5544	*****	*****	-0.5347	*****
-0.900	*****	0.2748	0.2462	0.1563	-0.5316	*****	*****	-0.5347	*****
-0.950	0.2229	0.2426	0.2368	0.1775	-0.1947	*****	*****	-0.5347	*****
-0.975	*****	0.1444	0.1686	0.1462	-0.0347	*****	*****	-0.5347	*****
-1.000	-1.2077	-1.1995	-0.8500	-0.7425	-0.4254	*****	*****	-0.5347	*****

Medium Radius L.E.
 Run No. = 5, Point No. = 94
 $C_N = 0.498$, $C_M = -0.0832$
 $\alpha = 11.4^\circ$, $M_\infty = 0.799$
 $R_{mac} = 5.9 \times 10^6$

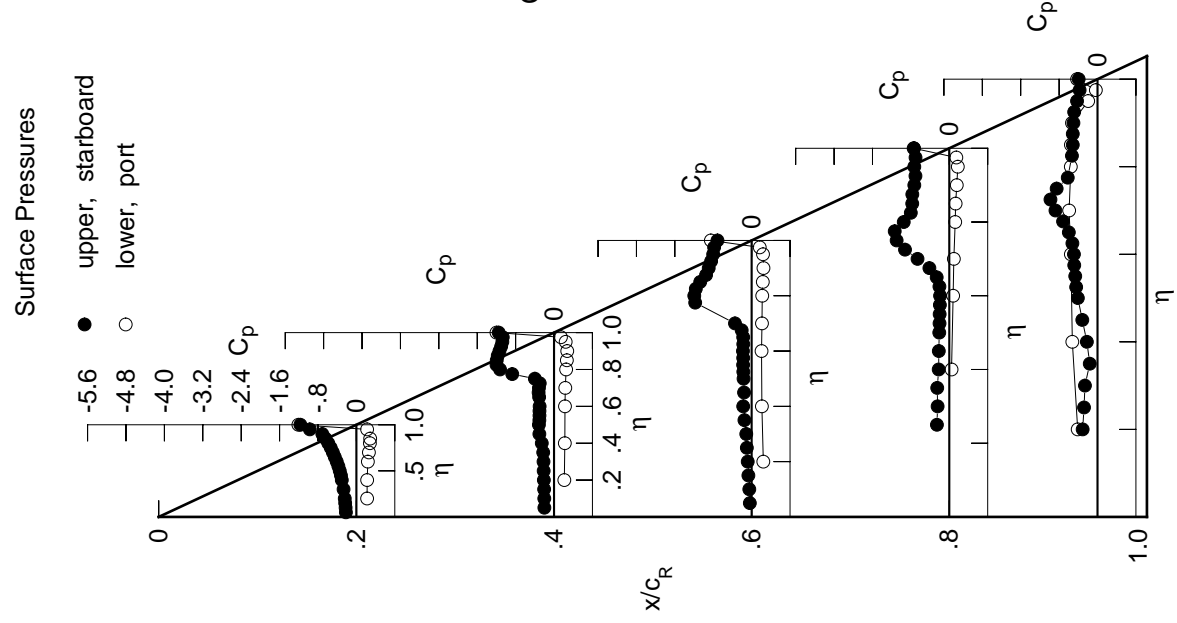
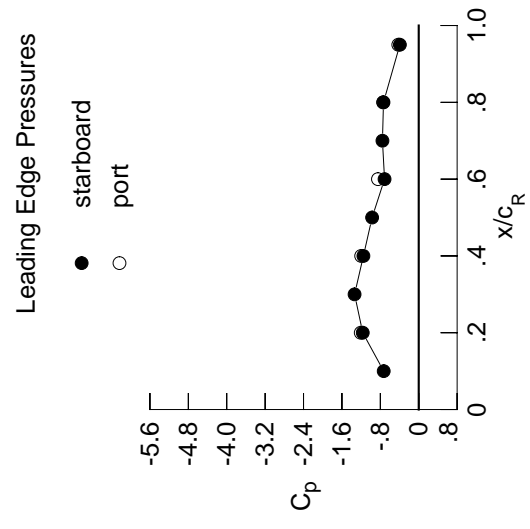

Table F1. Continued.

η	$x/c_R = .2$		$x/c_R = .4$		$x/c_R = .6$		$x/c_R = .8$		$x/c_R = .95$	
	$C_{p,u}$	$C_{p,u}$	$C_{p,u}$	$C_{p,u}$	$C_{p,u}$	$C_{p,u}$	$C_{p,u}$	$C_{p,u}$	$C_{p,u}$	$C_{p,u}$
0.050	-0.2394	-0.2325	-0.0559	*****	*****	*****	*****	*****	*****	*****
0.100	-0.2464	-0.2348	-0.0686	*****	*****	*****	*****	*****	*****	*****
0.150	-0.2580	-0.2380	-0.0865	*****	*****	*****	*****	*****	*****	*****
0.200	-0.2684	-0.2393	-0.1004	*****	*****	*****	*****	*****	*****	*****
0.250	*****	-0.2494	-0.1239	-0.2702	-0.2904	*****	*****	*****	*****	*****
0.300	-0.2965	-0.2651	-0.1546	-0.2642	-0.1859	*****	*****	*****	*****	*****
0.350	*****	-0.2926	-0.1627	-0.2435	-0.1884	*****	*****	*****	*****	*****
0.400	-0.3322	-0.2906	-0.1635	-0.2255	-0.2844	*****	*****	*****	*****	*****
0.450	-0.3506	-0.2997	-0.1602	-0.2191	-0.3868	*****	*****	*****	*****	*****
0.500	-0.3745	-0.2990	-0.1798	-0.2065	-0.4497	*****	*****	*****	*****	*****
0.525	*****	-0.3056	-0.1836	-0.2045	-0.4681	*****	*****	*****	*****	*****
0.550	-0.4040	-0.3075	-0.1927	-0.2084	-0.4789	*****	*****	*****	*****	*****
0.575	*****	-0.3097	-0.1996	-0.2256	-0.5052	*****	*****	*****	*****	*****
0.600	-0.4412	-0.3108	-0.2488	-0.2683	-0.5451	*****	*****	*****	*****	*****
0.625	*****	*****	-0.3032	-0.3720	-0.6344	*****	*****	*****	*****	*****
0.650	-0.4828	-0.3368	-0.4697	-0.5509	-0.7744	*****	*****	*****	*****	*****
0.675	*****	-0.4138	-0.6719	-0.7803	-0.9106	*****	*****	*****	*****	*****
0.700	-0.5156	-0.5995	-0.8712	-0.9802	-1.0221	*****	*****	*****	*****	*****
0.725	*****	-0.8061	*****	-1.1064	-1.0158	*****	*****	*****	*****	*****
0.750	-0.5495	-0.9389	*****	-1.1404	-0.7670	*****	*****	*****	*****	*****
0.775	*****	-1.0269	-1.1133	-1.0842	-0.6221	*****	*****	*****	*****	*****
0.800	-0.6291	-1.1081	-1.0806	-0.9397	*****	*****	*****	*****	*****	*****
0.825	*****	-1.1767	-1.0263	-0.8431	-0.5293	*****	*****	*****	*****	*****
0.850	-0.8920	-1.1943	-0.9613	-0.7959	-0.5105	*****	*****	*****	*****	*****
0.875	*****	-1.1650	-0.9244	-0.7756	-0.4914	*****	*****	*****	*****	*****
0.900	-1.1159	-1.1300	-0.8961	-0.7466	-0.4717	*****	*****	*****	*****	*****
0.925	*****	-1.0962	-0.8684	-0.7084	-0.4541	*****	*****	*****	*****	*****
0.950	-1.2021	-1.0684	-0.8335	-0.7237	-0.3892	*****	*****	*****	*****	*****
0.975	*****	-1.0483	-0.8114	-0.6980	-0.3405	*****	*****	*****	*****	*****
1.000	-1.2358	-1.0968	-0.7380	-0.7098	-0.3510	*****	*****	*****	*****	*****
-0.200	$C_{p,l}$	0.2518	0.2387	0.2591	*****	-0.4301	$C_{p,l}$	0.2518	0.2387	0.2591
-0.400	0.2523	0.2478	0.2323	0.0616	-0.5463	0.2523	0.2478	0.2323	0.0616	-0.5463
-0.600	0.2687	0.2523	0.2280	0.0955	-0.5990	0.2687	0.2523	0.2280	0.0955	-0.5990
-0.700	0.2890	0.2596	0.2357	0.1115	-0.6243	0.2890	0.2596	0.2357	0.1115	-0.6243
-0.800	0.3063	0.2757	0.2394	0.1382	-0.5671	0.3063	0.2757	0.2394	0.1382	-0.5671
-0.850	0.3079	0.2890	0.2513	0.1476	-0.5558	0.3079	0.2890	0.2513	0.1476	-0.5558
-0.900	*****	0.2893	0.2601	0.1712	-0.5249	*****	0.2893	0.2601	0.1712	-0.5249
-0.950	0.2205	0.2449	0.2389	0.1809	-0.1879	0.2205	0.2449	0.2389	0.1809	-0.1879
-0.975	*****	0.1312	0.1567	0.1390	-0.0350	*****	0.1312	0.1567	0.1390	-0.0350
-1.000	-1.2850	-1.1165	-0.8346	-0.7503	-0.3847	-1.2850	-1.1165	-0.8346	-0.7503	-0.3847

Medium Radius L.E.
 Run No. = 5 , Point No. = 95
 $C_N = 0.557$, $C_m = -0.0943$
 $\alpha = 12.4^\circ$, $M_\infty = 0.798$
 $R_{mac} = 5.9 \times 10^6$

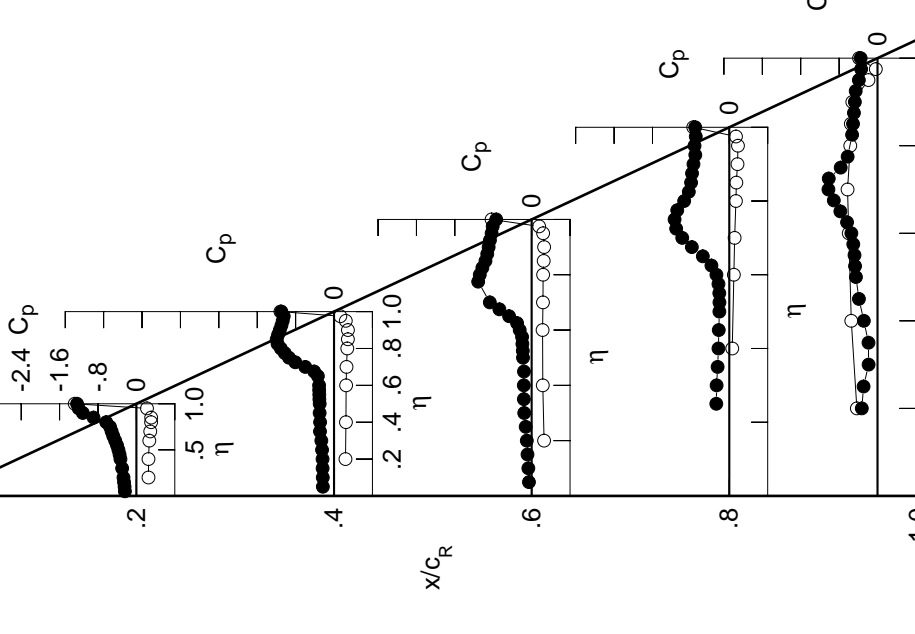
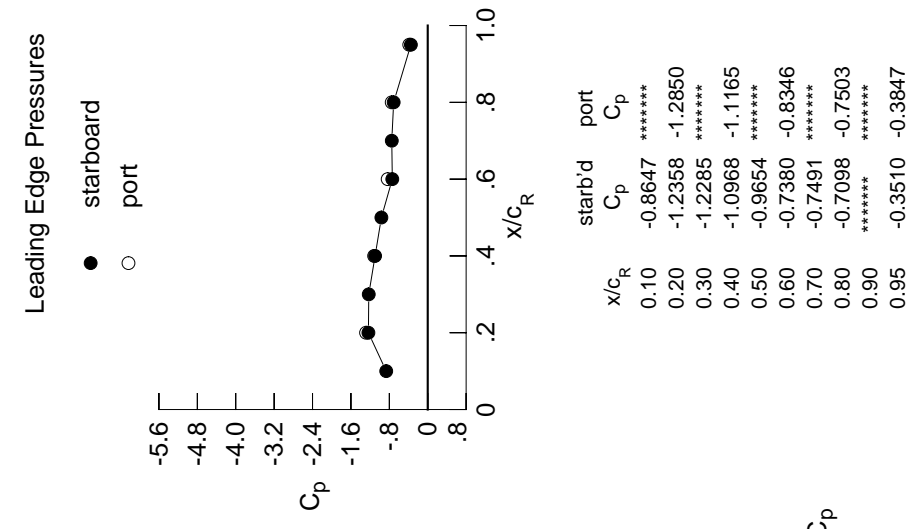
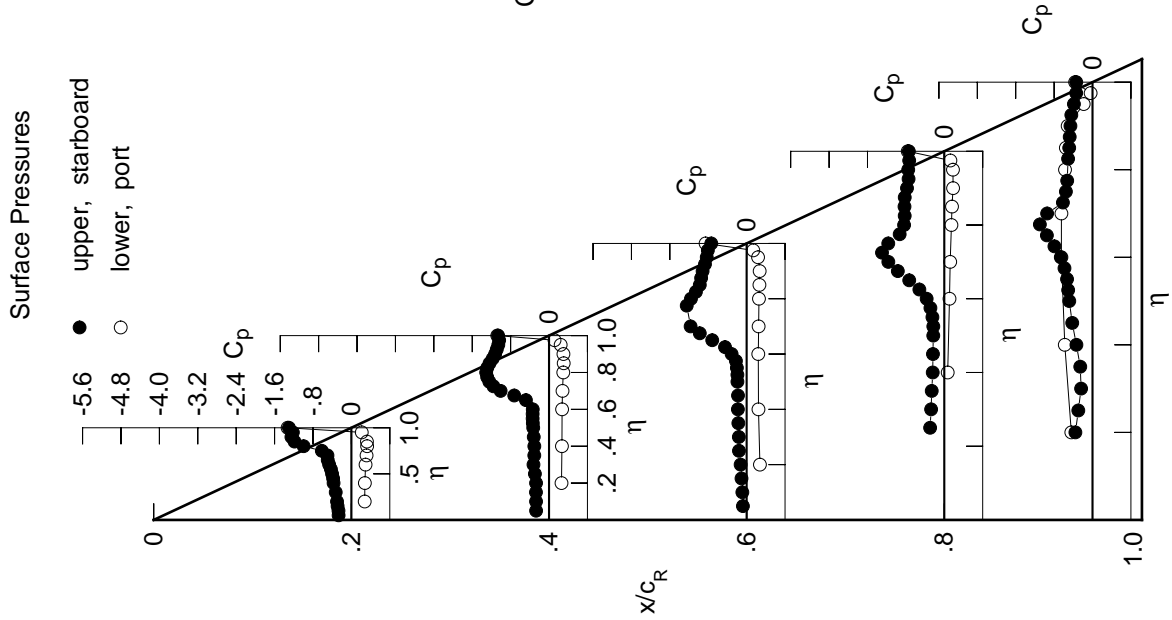
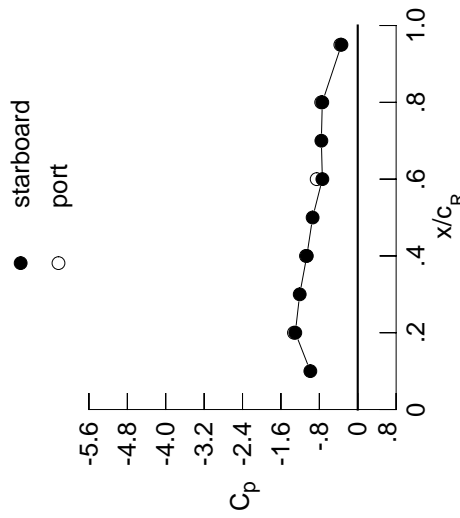

Table F1. Continued.

η	x/c_R	x/c_R	x/c_R	x/c_R	x/c_R	x/c_R	x/c_R
	$C_{p,u}$	$C_{p,u}$	$C_{p,u}$	$C_{p,u}$	$C_{p,u}$	$C_{p,u}$	$C_{p,u}$
0.050	-0.2661	-0.2698	-0.0775	*****	*****	*****	*****
0.100	-0.2687	-0.2705	-0.0898	*****	*****	*****	*****
0.150	-0.2873	-0.2721	-0.1071	*****	*****	*****	*****
0.200	-0.2991	-0.2706	-0.1259	*****	*****	-0.3565	*****
0.250	*****	-0.2947	-0.1603	-0.2951	-0.2956	*****	*****
0.300	-0.3265	-0.3237	-0.1620	-0.2745	-0.2380	*****	*****
0.350	*****	-0.3073	-0.1725	-0.2613	-0.2550	*****	*****
0.400	-0.3710	-0.3065	-0.1823	-0.2404	-0.3353	*****	*****
0.450	-0.3808	-0.3184	-0.1800	-0.2362	-0.4227	*****	*****
0.500	-0.4022	-0.3295	-0.1919	-0.2294	-0.4838	*****	*****
0.525	*****	-0.3380	-0.1926	-0.2285	-0.5076	*****	*****
0.550	-0.4266	-0.3413	-0.2033	-0.2473	-0.5302	*****	*****
0.575	*****	-0.3416	-0.2233	-0.2886	-0.5844	*****	*****
0.600	-0.4633	-0.3390	-0.3125	-0.3669	-0.6607	*****	*****
0.625	*****	*****	-0.4506	-0.5196	-0.7933	*****	*****
0.650	-0.4931	-0.4813	-0.7168	-0.7308	-0.9505	*****	*****
0.675	*****	-0.7246	-0.9759	-0.9678	-1.0966	*****	*****
0.700	-0.4982	-1.0089	-1.1670	-1.1653	-0.9457	*****	*****
0.725	*****	-1.1588	*****	-1.2977	-0.6171	*****	*****
0.750	-0.6159	-1.2442	*****	-1.1672	-0.5547	*****	*****
0.775	*****	-1.2886	-1.2480	-0.9299	-0.5270	*****	*****
0.800	-0.9953	-1.3093	-1.1599	-0.8377	*****	*****	*****
0.825	*****	-1.2872	-1.0568	-0.8251	-0.5089	*****	*****
0.850	-1.1849	-1.2389	-0.9758	-0.8285	-0.4858	*****	*****
0.875	*****	-1.1746	-0.9476	-0.8241	-0.4754	*****	*****
0.900	-1.2497	-1.1232	-0.9175	-0.7771	-0.4601	*****	*****
0.925	*****	-1.0884	-0.8678	-0.7437	-0.4418	*****	*****
0.950	-1.2192	-1.0568	-0.8308	-0.7516	-0.3868	*****	*****
0.975	*****	-1.0388	-0.8082	-0.7309	-0.3403	*****	*****
1.000	-1.3004	-1.0609	-0.7371	-0.7384	-0.3389	*****	*****
-0.200	0.2773	0.2597	0.2764	*****	-0.4413	*****	*****
-0.400	0.2810	0.2688	0.2467	0.0710	-0.5776	*****	*****
-0.600	0.2955	0.2720	0.2426	0.1086	-0.6484	*****	*****
-0.700	0.3157	0.2806	0.2499	0.1230	-0.6479	*****	*****
-0.800	0.3280	0.2967	0.2568	0.1489	-0.5726	*****	*****
-0.850	0.3244	0.3057	0.2662	0.1607	-0.5551	*****	*****
-0.900	*****	0.3000	0.2716	0.1829	-0.5177	*****	*****
-0.950	0.2160	0.2427	0.2374	0.1812	-0.1843	*****	*****
-0.975	*****	0.1141	0.1384	0.1270	-0.0395	*****	*****
-1.000	-1.3290	-1.0782	-0.8554	-0.7620	-0.3628	*****	*****

Medium Radius L.E.
 Run No. = 5, Point No. = 96
 $C_N = 0.607$, $C_m = -0.0992$
 $\alpha = 13.4^\circ$, $M_\infty = 0.798$
 $R_{mac} = 5.9 \times 10^6$

Leading Edge Pressures



x/c_R	starb'd C_p	port C_p
0.10	-0.9875	*****
0.20	-1.3004	-1.3290
0.30	-1.2088	*****
0.40	-1.0609	-1.0782
0.50	-0.9397	*****
0.60	-0.7371	-0.8554
0.70	-0.7577	*****
0.80	-0.7384	-0.7620
0.90	*****	*****
0.95	-0.3389	-0.3628

Table F1. Continued.

η	$x/c_R = .2$		$x/c_R = .4$		$x/c_R = .6$		$x/c_R = .8$		$x/c_R = .95$	
	$C_{p,u}$	$C_{p,u}$	$C_{p,u}$	$C_{p,u}$	$C_{p,u}$	$C_{p,u}$	$C_{p,u}$	$C_{p,u}$	$C_{p,u}$	$C_{p,u}$
0.050	-0.2842	-0.3029	-0.0969	*****	*****	*****	*****	*****	*****	*****
0.100	-0.2841	-0.3008	-0.1069	*****	*****	*****	*****	*****	*****	*****
0.150	-0.3104	-0.3065	-0.1249	*****	*****	*****	*****	*****	*****	*****
0.200	-0.3300	-0.3124	-0.1554	*****	*****	*****	*****	*****	*****	-0.3347
0.250	*****	-0.3462	-0.1676	-0.3061	-0.2421	*****	*****	*****	*****	-0.2421
0.300	-0.3579	-0.3310	-0.1740	-0.2807	-0.2161	*****	*****	*****	*****	-0.2161
0.350	*****	-0.3281	-0.1826	-0.2663	-0.2659	*****	*****	*****	*****	-0.2659
0.400	-0.3864	-0.3334	-0.1935	-0.2533	-0.3584	*****	*****	*****	*****	-0.3584
0.450	-0.3933	-0.3379	-0.1910	-0.2493	-0.4411	*****	*****	*****	*****	-0.4411
0.500	-0.4133	-0.3418	-0.2131	-0.2610	-0.5064	*****	*****	*****	*****	-0.5064
0.525	*****	-0.3462	-0.2264	-0.2795	-0.5441	*****	*****	*****	*****	-0.5441
0.550	-0.4354	-0.3521	-0.2584	-0.3266	-0.5987	*****	*****	*****	*****	-0.5987
0.575	*****	-0.3687	-0.3235	-0.4117	-0.6913	*****	*****	*****	*****	-0.6913
0.600	-0.4575	-0.4129	-0.4871	-0.5409	-0.8134	*****	*****	*****	*****	-0.8134
0.625	*****	*****	-0.6900	-0.7289	-0.9660	*****	*****	*****	*****	-0.9660
0.650	-0.4447	-0.8628	-0.9686	-0.9392	-1.1202	*****	*****	*****	*****	-1.1202
0.675	*****	-1.1521	-1.1941	-1.1490	-0.7942	*****	*****	*****	*****	-0.7942
0.700	-0.5431	-1.3186	-1.3478	-1.2978	-0.5950	*****	*****	*****	*****	-0.5950
0.725	*****	-1.3488	*****	-1.0963	-0.5465	*****	*****	*****	*****	-0.5465
0.750	-1.0938	-1.3733	*****	-0.9013	-0.5222	*****	*****	*****	*****	-0.5222
0.775	*****	-1.3906	-1.1755	-0.8590	-0.5038	*****	*****	*****	*****	-0.5038
0.800	-1.2819	-1.3629	-1.0645	-0.8481	*****	*****	*****	*****	*****	-0.8481
0.825	*****	-1.3020	-1.0115	-0.8594	-0.4787	*****	*****	*****	*****	-0.4787
0.850	-1.3033	-1.2248	-0.9943	-0.8751	-0.4515	*****	*****	*****	*****	-0.4515
0.875	*****	-1.1623	-0.9887	-0.8405	-0.4362	*****	*****	*****	*****	-0.4362
0.900	-1.2719	-1.1189	-0.9371	-0.7913	-0.4175	*****	*****	*****	*****	-0.4175
0.925	*****	-1.0866	-0.8859	-0.7725	-0.3998	*****	*****	*****	*****	-0.3998
0.950	-1.2426	-1.0551	-0.8592	-0.7774	-0.3556	*****	*****	*****	*****	-0.3556
0.975	*****	-1.0449	-0.8453	-0.7567	-0.3157	*****	*****	*****	*****	-0.3157
1.000	-1.3357	-1.0555	-0.7623	-0.7568	-0.3188	*****	*****	*****	*****	-0.3188
-0.200	$C_{p,l}$	$C_{p,l}$	$C_{p,l}$	$C_{p,l}$	$C_{p,l}$	$C_{p,l}$	$C_{p,l}$	$C_{p,l}$	$C_{p,l}$	$C_{p,l}$
-0.400	0.3076	0.2845	0.2943	*****	-0.4649	*****	*****	*****	*****	-0.4649
-0.600	0.3100	0.2955	0.2656	0.0889	-0.5972	*****	*****	*****	*****	-0.5972
-0.700	0.3223	0.2960	0.2624	0.1202	-0.6596	*****	*****	*****	*****	-0.6596
-0.800	0.3395	0.3054	0.2689	0.1386	-0.6430	*****	*****	*****	*****	-0.6430
-0.850	0.3470	0.3176	0.2745	0.1632	-0.5662	*****	*****	*****	*****	-0.5662
-0.900	0.3398	0.3215	0.2835	0.1745	-0.5445	*****	*****	*****	*****	-0.5445
-0.950	0.2084	0.2378	0.2364	0.1931	-0.5034	*****	*****	*****	*****	-0.5034
-0.975	*****	0.0939	0.1247	0.1166	-0.1755	*****	*****	*****	*****	-0.1755
-1.000	-1.3355	-1.0913	-0.8549	-0.7677	-0.3379	*****	*****	*****	*****	-0.3379

Medium Radius L.E.
 Run No. = 5, Point No. = 97
 $C_N = 0.657$, $C_M = -0.1041$
 $\alpha = 14.4^\circ$, $M_\infty = 0.799$
 $R_{mac} = 5.9 \times 10^6$

Leading Edge Pressures

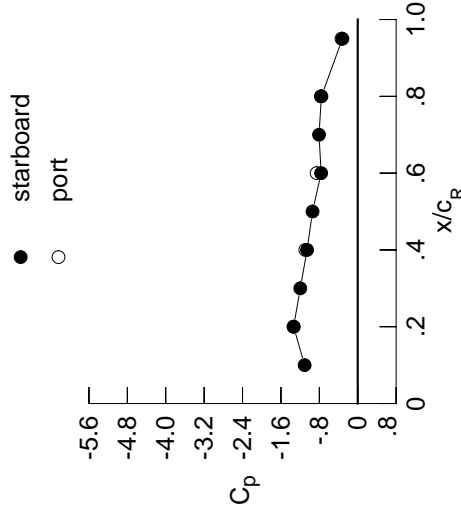

x/c_R	starb'd C_p	port C_p
0.10	-1.1063	*****
0.20	-1.3357	-1.3355
0.30	-1.1971	*****
0.40	-1.0555	-1.0913
0.50	-0.9417	*****
0.60	-0.7623	-0.8549
0.70	-0.8064	*****
0.80	-0.7568	-0.7677
0.90	*****	*****
0.95	-0.3188	-0.3379

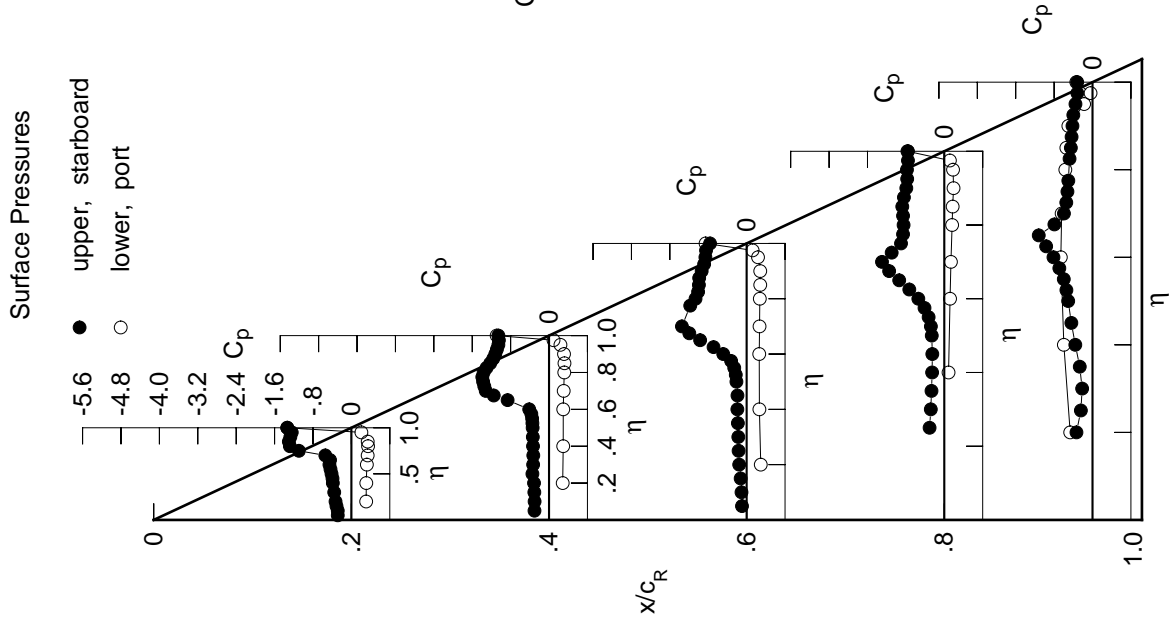
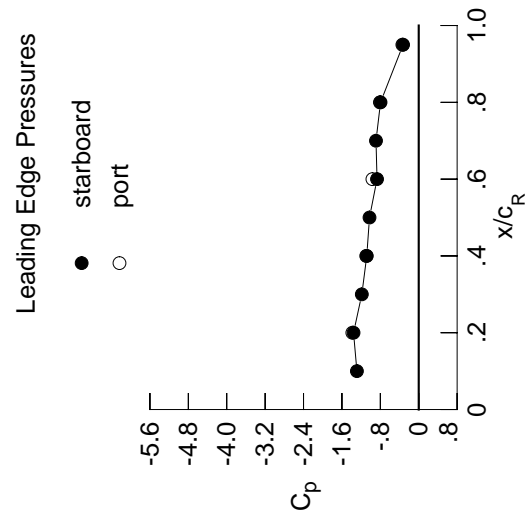

Table F1. Continued.

η	x/c_R	$C_{p,u}$	x/c_R	$C_{p,u}$	x/c_R	$C_{p,u}$	x/c_R	$C_{p,u}$
0.050	.2	-0.3455	.4	-0.3762	.6	-0.1429	.8	0.3275
0.100		-0.3396		-0.3758		-0.1510		0.3385
0.150		-0.3678		-0.3796		-0.1719		0.2948
0.200		-0.4120		-0.3993		-0.1989		0.3015
0.250		*****		-0.4006		-0.2087		0.3545
0.300		-0.4064		-0.3949		-0.2212		0.3700
0.350		*****		-0.3970		-0.2342		0.3294
0.400		-0.4401		-0.4013		-0.2512		0.2987
0.450		-0.4556		-0.4027		-0.2677		0.2282
0.500		-0.4629		-0.4069		-0.3475		0.2133
0.525		*****		-0.4320		-0.4216		0.1808
0.550		-0.4556		-0.4847		-0.5376		0.0546
0.575		*****		-0.6049		-0.6912		-0.0883
0.600		-0.4101		-0.8086		-0.9136		-0.8078
0.625		*****		*****		-1.1193		-1.0934
0.650		-0.6801		-1.3684		-1.3187		-1.3829
0.675		*****		-1.5531		-1.4737		-1.3581
0.700		-1.4295		-1.6586		-1.3791		-1.0257
0.725		*****		-1.6672		*****		-0.8686
0.750		-1.5282		-1.5643		*****		-0.9651
0.775		*****		-1.4880		-1.0995		-0.8904
0.800		-1.4902		-1.3784		-1.0946		-0.7958
0.825		*****		-1.2830		-1.1055		-0.3262
0.850		-1.4013		-1.2391		-1.0958		0.3269
0.875		*****		-1.2178		-1.0374		0.3664
0.900		-1.3213		-1.1828		-0.9918		0.3798
0.925		*****		-1.1304		-0.9835		0.3919
0.950		-1.2940		-1.1003		-0.9822		0.3889
0.975		*****		-1.0886		-0.9654		0.3700
1.000		-1.3581		-1.0826		-0.8686		0.3294
-0.200		0.3592		0.3269		0.3275		0.3275
-0.400		0.3664		0.3385		0.2995		0.2995
-0.600		0.3798		0.3381		0.2948		0.2948
-0.700		0.3919		0.3475		0.3015		0.3015
-0.800		0.3889		0.3545		0.3063		0.3063
-0.850		0.3700		0.3541		0.3099		0.3099
-0.900		0.3294		0.3294		0.2987		0.2987
-0.950		0.1952		0.2283		0.2235		0.2235
-0.975		0.0546		0.0546		0.0791		0.0791
-1.000		-1.3829		-1.0934		-0.9651		-0.8078

Medium Radius L.E.
 Run No. = 5, Point No. = 98
 $C_N = 0.760$, $C_M = -0.1180$
 $\alpha = 16.5^\circ$, $M_\infty = 0.799$
 $R_{mac} = 5.9 \times 10^6$



x/c_R	starb'd C_p	port C_p
0.10	-1.2879	*****
0.20	-1.3581	*****
0.30	-1.1853	*****
0.40	-1.0826	-1.0934
0.50	-1.0257	*****
0.60	-0.8686	-0.9651
0.70	-0.8904	*****
0.80	-0.7958	-0.8078
0.90	*****	*****
0.95	-0.3262	-0.3407

Table F1. Continued.

η	x/c_R	x/c_R	x/c_R	x/c_R	x/c_R	x/c_R	x/c_R
	$C_{p,u}$	$C_{p,u}$	$C_{p,u}$	$C_{p,u}$	$C_{p,u}$	$C_{p,u}$	$C_{p,u}$
0.050	-0.4099	-0.4518	-0.1888	*****	*****	*****	*****
0.100	-0.4087	-0.4527	-0.1992	*****	*****	*****	*****
0.150	-0.4492	-0.4741	-0.2259	*****	*****	*****	*****
0.200	-0.4693	-0.4692	-0.2435	*****	*****	*****	-0.3779
0.250	*****	-0.4704	-0.2586	-0.3861	-0.4151		
0.300	-0.4558	-0.4718	-0.2790	-0.3633	-0.4132		
0.350	*****	-0.4767	-0.3068	-0.3641	-0.4420		
0.400	-0.4818	-0.4880	-0.3550	-0.3713	-0.5004		
0.450	-0.4871	-0.5140	-0.4378	-0.4378	-0.5903		
0.500	-0.4753	-0.5978	-0.6383	-0.5895	-0.7326		
0.525	*****	-0.7041	-0.7740	-0.7066	-0.8349		
0.550	-0.4686	-0.8585	-0.9427	-0.8571	-0.9445		
0.575	*****	-1.0610	-1.1069	-1.0258	-1.0659		
0.600	-0.9020	-1.2684	-1.2947	-1.1868	-0.7425		
0.625	*****	*****	-1.4338	-1.3461	-0.6487		
0.650	-1.5988	-1.6433	-1.5539	-1.4326	-0.6495		
0.675	*****	-1.7333	-1.2666	-1.0609	-0.6479		
0.700	-1.6828	-1.5612	-1.1868	-1.0123	-0.6460		
0.725	*****	-1.4685	*****	-0.9987	-0.6271		
0.750	-1.6424	-1.4547	*****	-1.0041	-0.5944		
0.775	*****	-1.4533	-1.1645	-1.0161	-0.5230		
0.800	-1.5649	-1.4721	-1.1810	-1.0352	*****		
0.825	*****	-1.4743	-1.1829	-1.0468	-0.4216		
0.850	-1.4424	-1.4166	-1.1482	-1.0284	-0.4046		
0.875	*****	-1.3057	-1.0941	-0.9487	-0.4250		
0.900	-1.3535	-1.2265	-1.0664	-0.8692	-0.4342		
0.925	*****	-1.2011	-1.0527	-0.8313	-0.4468		
0.950	-1.3116	-1.1985	-1.0437	-0.8269	-0.3949		
0.975	*****	-1.1896	-1.0353	-0.8124	-0.3634		
1.000	-1.3324	-1.1839	-0.9347	-0.7976	-0.3536		
-0.200	0.4163	0.3729	0.3660	*****	-0.5123		
-0.400	0.4220	0.3852	0.3367	0.1466	-0.6469		
-0.600	0.4329	0.3833	0.3319	0.1810	-0.6490		
-0.700	0.4411	0.3914	0.3381	0.1935	-0.6166		
-0.800	0.4246	0.3908	0.3388	0.2183	-0.5315		
-0.850	0.3986	0.3823	0.3377	0.2256	-0.5031		
-0.900	*****	0.3426	0.3146	0.2321	-0.4521		
-0.950	0.1800	0.2130	0.2125	0.1803	-0.1537		
-0.975	*****	0.0082	0.0380	0.0596	-0.0620		
-1.000	-1.3617	-1.1756	-1.0227	-0.8162	-0.3639		

Medium Radius L.E.
 Run No. = 5, Point No. = 99
 $C_N = 0.874$, $C_M = -0.1367$
 $\alpha = 18.5^\circ$, $M_\infty = 0.799$
 $R_{mac} = 5.9 \times 10^6$

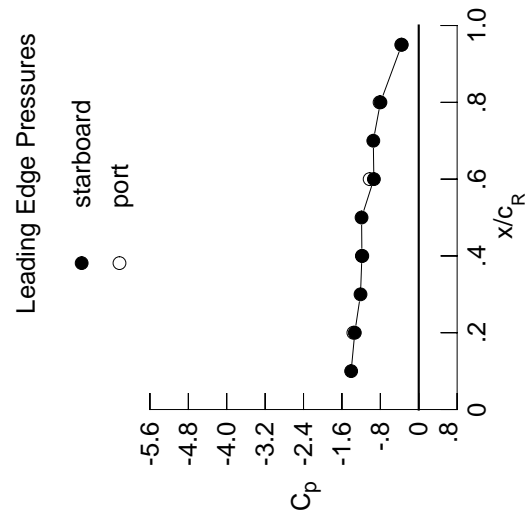

x/c_R	starb'd C_p	port C_p
0.10	-1.4078	*****
0.20	-1.3324	-1.3617
0.30	-1.2128	*****
0.40	-1.1839	-1.1756
0.50	-1.1908	*****
0.60	-0.9347	-1.0227
0.70	-0.9467	*****
0.80	-0.7976	-0.8162
0.90	*****	*****
0.95	-0.3536	-0.3639

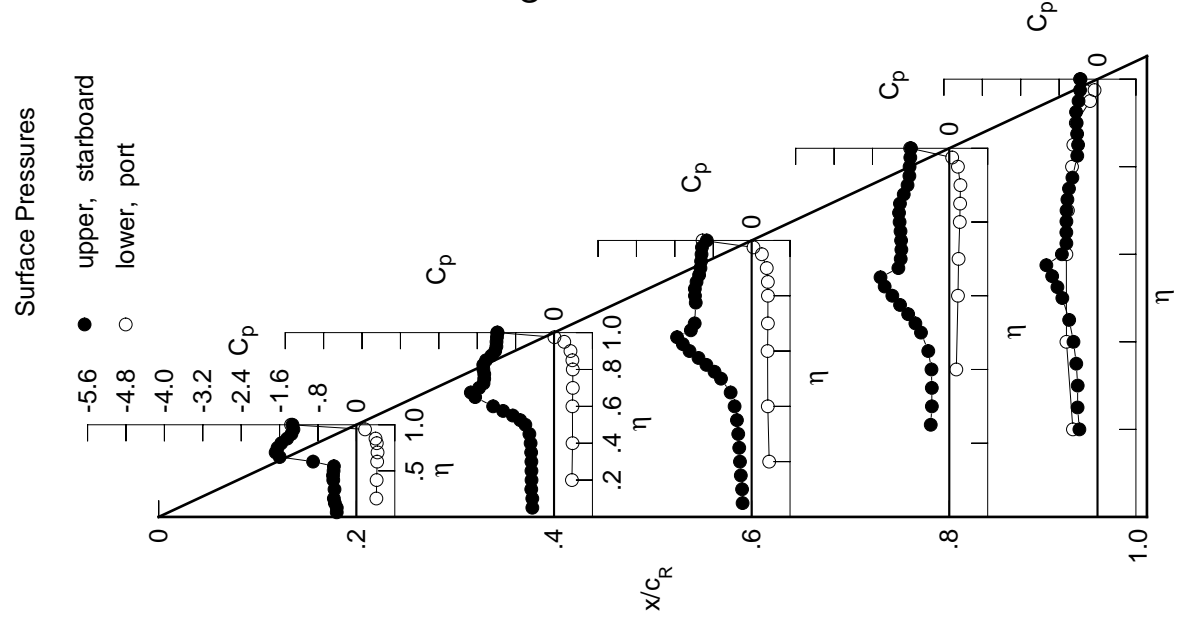

Table F1. Continued.

η	$x/c_R = .2$		$x/c_R = .4$		$x/c_R = .6$		$x/c_R = .8$		$x/c_R = .95$	
	$C_{p,u}$	$C_{p,u}$	$C_{p,u}$	$C_{p,u}$	$C_{p,u}$	$C_{p,u}$	$C_{p,u}$	$C_{p,u}$	$C_{p,u}$	$C_{p,u}$
0.050	-0.4767	-0.5301	-0.2197	*****	*****	*****	*****	*****	*****	*****
0.100	-0.4844	-0.5305	-0.2323	*****	*****	*****	*****	*****	*****	*****
0.150	-0.5222	-0.5552	-0.2510	*****	*****	*****	*****	*****	*****	*****
0.200	-0.5112	-0.5448	-0.2802	*****	*****	*****	*****	*****	*****	-0.3642
0.250	*****	-0.5542	-0.2971	-0.4231	-0.4561	*****	*****	*****	*****	-0.4561
0.300	-0.5175	-0.5590	-0.3271	-0.4145	-0.5129	*****	*****	*****	*****	-0.5129
0.350	*****	-0.5734	-0.3769	-0.4292	-0.5581	*****	*****	*****	*****	-0.5581
0.400	-0.5477	-0.6102	-0.4713	-0.4661	-0.6176	*****	*****	*****	*****	-0.6176
0.450	-0.5473	-0.6974	-0.6368	-0.5811	-0.7172	*****	*****	*****	*****	-0.7172
0.500	-0.5834	-0.8846	-0.9180	-0.7752	-0.8571	*****	*****	*****	*****	-0.8571
0.525	*****	-1.0421	-1.0751	-0.9042	-0.9375	*****	*****	*****	*****	-0.9375
0.550	-0.8906	-1.2125	-1.2360	-1.0513	-0.9618	*****	*****	*****	*****	-0.9618
0.575	*****	-1.3848	-1.3758	-1.2011	-0.6553	*****	*****	*****	*****	-0.6553
0.600	-1.5255	-1.5355	-1.5161	-1.3387	-0.6087	*****	*****	*****	*****	-0.6087
0.625	*****	*****	-1.6152	-1.4657	-0.6156	*****	*****	*****	*****	-0.6156
0.650	-1.8410	-1.6361	-1.4390	-1.1015	-0.6184	*****	*****	*****	*****	-0.6184
0.675	*****	-1.4502	-1.2910	-1.0235	-0.6079	*****	*****	*****	*****	-0.6079
0.700	-1.8345	-1.4253	-1.2676	-1.0138	-0.5820	*****	*****	*****	*****	-0.5820
0.725	*****	-1.4216	*****	-1.0052	-0.5221	*****	*****	*****	*****	-0.5221
0.750	-1.7581	-1.4377	*****	-1.0108	-0.4678	*****	*****	*****	*****	-0.4678
0.775	*****	-1.4611	-1.2474	-1.0287	-0.4362	*****	*****	*****	*****	-0.4362
0.800	-1.6225	-1.5045	-1.2577	-1.0675	*****	*****	*****	*****	*****	*****
0.825	*****	-1.4780	-1.2635	-1.1220	-0.4646	*****	*****	*****	*****	-0.4646
0.850	-1.4634	-1.4010	-1.2405	-1.1079	-0.4689	*****	*****	*****	*****	-0.4689
0.875	*****	-1.3405	-1.1838	-0.9909	-0.4834	*****	*****	*****	*****	-0.4834
0.900	-1.3835	-1.3316	-1.1479	-0.8746	-0.4863	*****	*****	*****	*****	-0.4863
0.925	*****	-1.3365	-1.1274	-0.8283	-0.5008	*****	*****	*****	*****	-0.5008
0.950	-1.3355	-1.3372	-1.1202	-0.8278	-0.4445	*****	*****	*****	*****	-0.4445
0.975	*****	-1.3272	-1.1096	-0.8101	-0.4084	*****	*****	*****	*****	-0.4084
1.000	-1.3379	-1.3321	-1.0028	-0.7871	-0.3976	*****	*****	*****	*****	-0.3976
	$C_{p,l}$	$C_{p,l}$	$C_{p,l}$	$C_{p,l}$	$C_{p,l}$	$C_{p,l}$	$C_{p,l}$	$C_{p,l}$	$C_{p,l}$	$C_{p,l}$
-0.200	0.4722	0.4202	0.3993	*****	-0.5423	*****	*****	*****	*****	-0.5423
-0.400	0.4759	0.4289	0.3770	0.1766	-0.6397	*****	*****	*****	*****	-0.6397
-0.600	0.4818	0.4269	0.3669	0.2107	-0.6291	*****	*****	*****	*****	-0.6291
-0.700	0.4830	0.4302	0.3716	0.2235	-0.5955	*****	*****	*****	*****	-0.5955
-0.800	0.4568	0.4231	0.3687	0.2437	-0.5091	*****	*****	*****	*****	-0.5091
-0.850	0.4188	0.4046	0.3607	0.2496	-0.4811	*****	*****	*****	*****	-0.4811
-0.900	*****	0.3491	0.3247	0.2478	-0.4282	*****	*****	*****	*****	-0.4282
-0.950	0.1595	0.1927	0.1950	0.1761	-0.1479	*****	*****	*****	*****	-0.1479
-0.975	*****	-0.0421	-0.0061	0.0317	-0.0806	*****	*****	*****	*****	-0.0806
-1.000	-1.3757	-1.3438	-1.0939	-0.7996	-0.4092	*****	*****	*****	*****	-0.4092

Medium Radius L.E.

Run No. = 5, Point No. = 100

$C_N = 0.982$, $C_m = -0.1546$

$\alpha = 20.5^\circ$, $M_\infty = 0.799$

$R_{mac} = 5.9 \times 10^6$

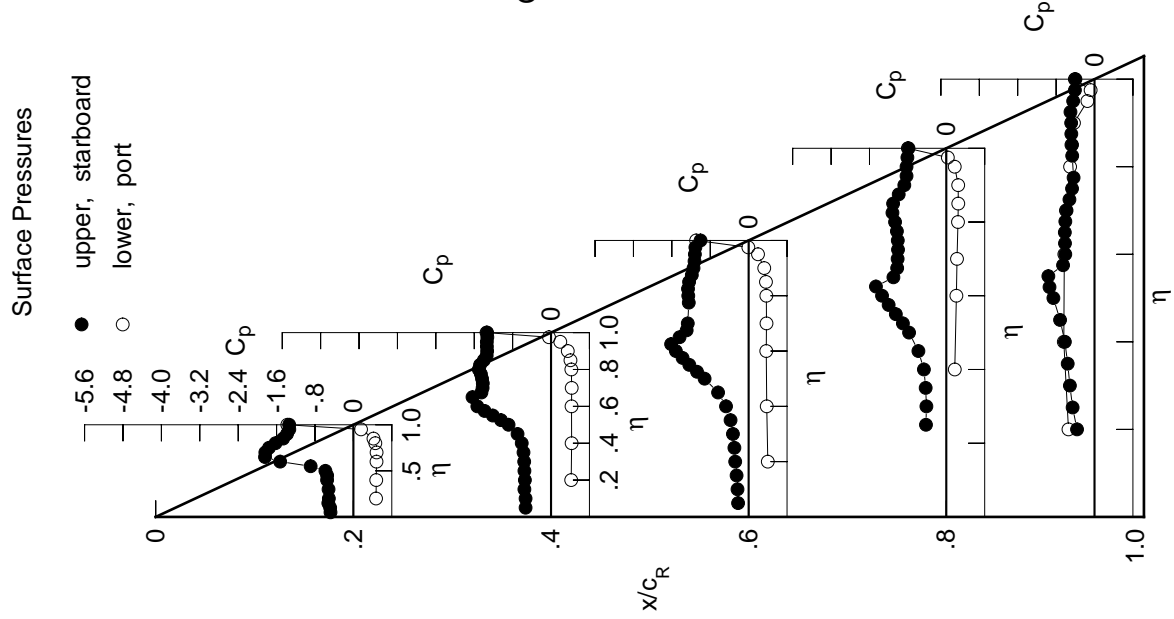

Leading Edge Pressures

- starboard
- port

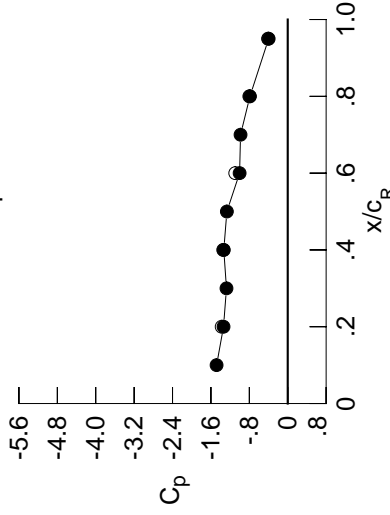

x/c_R	starb'd C_p	port C_p
0.10	-1.4821	*****
0.20	-1.3379	-1.3757
0.30	-1.2763	*****
0.40	-1.3321	-1.3438
0.50	-1.2679	*****
0.60	-1.0028	-1.0939
0.70	-0.9833	*****
0.80	-0.7871	-0.7996
0.90	*****	*****
0.95	-0.3976	-0.4092

Table F1. Continued.

η	x/c_R .2	$C_{p,u}$	x/c_R .4	$C_{p,u}$	x/c_R .6	$C_{p,u}$	x/c_R .8	$C_{p,u}$	x/c_R .95	$C_{p,u}$
0.050	-0.5570	-0.6082	-0.2564	*****	*****	*****	*****	*****	*****	
0.100	-0.5702	-0.6103	-0.2689	*****	*****	*****	*****	*****	*****	
0.150	-0.5994	-0.6161	-0.2897	*****	*****	*****	*****	*****	*****	
0.200	-0.5905	-0.6407	-0.3132	*****	*****	*****	*****	*****	-0.3633	
0.250	*****	-0.6433	-0.3489	-0.4755	-0.5058	*****	*****	*****	*****	
0.300	-0.5938	-0.6700	-0.4044	-0.4731	-0.5922	*****	*****	*****	*****	
0.350	*****	-0.7101	-0.4867	-0.5135	-0.6568	*****	*****	*****	*****	
0.400	-0.6359	-0.8037	-0.6180	-0.5796	-0.7536	*****	*****	*****	*****	
0.450	-0.6997	-0.9594	-0.8403	-0.7377	-0.8594	*****	*****	*****	*****	
0.500	-0.9388	-1.1975	-1.1390	-0.9602	-0.9852	*****	*****	*****	*****	
0.525	*****	-1.3374	-1.2942	-1.0905	-0.9902	*****	*****	*****	*****	
0.550	-1.3992	-1.4723	-1.4330	-1.2268	-0.6440	*****	*****	*****	*****	
0.575	*****	-1.5965	-1.5526	-1.3592	-0.5995	*****	*****	*****	*****	
0.600	-1.7789	-1.6995	-1.6604	-1.4705	-0.5794	*****	*****	*****	*****	
0.625	*****	*****	-1.6579	-1.1662	-0.5647	*****	*****	*****	*****	
0.650	-1.8880	-1.4954	-1.3771	-1.0368	-0.5481	*****	*****	*****	*****	
0.675	*****	-1.4829	-1.3435	-1.0170	-0.5286	*****	*****	*****	*****	
0.700	-1.8733	-1.4717	-1.3376	-1.0097	-0.5192	*****	*****	*****	*****	
0.725	*****	-1.4757	*****	-1.0096	-0.5195	*****	*****	*****	*****	
0.750	-1.8671	-1.4938	*****	-1.0146	-0.5228	*****	*****	*****	*****	
0.775	*****	-1.5176	-1.3682	-1.0389	-0.5269	*****	*****	*****	*****	
0.800	-1.6413	-1.5121	-1.4013	-1.0942	*****	*****	*****	*****	*****	
0.825	*****	-1.4755	-1.4040	-1.1424	-0.5320	*****	*****	*****	*****	
0.850	-1.4653	-1.4426	-1.3608	-1.1174	-0.5167	*****	*****	*****	*****	
0.875	*****	-1.4350	-1.2761	-0.9711	-0.5138	*****	*****	*****	*****	
0.900	-1.4071	-1.4316	-1.2230	-0.8471	-0.5125	*****	*****	*****	*****	
0.925	*****	-1.4325	-1.1996	-0.7971	-0.5320	*****	*****	*****	*****	
0.950	-1.3751	-1.4194	-1.1935	-0.8010	-0.4904	*****	*****	*****	*****	
0.975	*****	-1.4129	-1.1726	-0.7768	-0.4705	*****	*****	*****	*****	
1.000	-1.3778	-1.4143	-1.10578	-0.7429	-0.4497	*****	*****	*****	*****	
-0.200	$C_{p,l}$	0.4676	0.4362	*****	*****	*****	*****	*****	-0.5507	
-0.400	0.5290	0.4740	0.4136	0.2063	-0.6255	*****	*****	*****	*****	
-0.600	0.5310	0.4670	0.4024	0.2419	-0.6117	*****	*****	*****	*****	
-0.700	0.5260	0.4691	0.4070	0.2512	-0.5744	*****	*****	*****	*****	
-0.800	0.4854	0.4541	0.3970	0.2701	-0.4910	*****	*****	*****	*****	
-0.850	0.4371	0.4265	0.3827	0.2719	-0.4613	*****	*****	*****	*****	
-0.900	*****	0.3568	0.3338	0.2625	-0.4103	*****	*****	*****	*****	
-0.950	0.1379	0.1734	0.1776	0.1709	-0.1475	*****	*****	*****	*****	
-0.975	*****	-0.0863	-0.0488	0.0074	-0.1041	*****	*****	*****	*****	
-1.000	-1.4169	-1.4103	-1.1620	-0.7379	-0.4534	*****	*****	*****	*****	

Medium Radius L.E.
 Run No. = 5, Point No. = 101
 $C_N = 1.079$, $C_m = -0.1671$
 $\alpha = 22.6^\circ$, $M_\infty = 0.799$
 $R_{mac} = 5.9 \times 10^6$

Leading Edge Pressures

● starboard
 ○ port

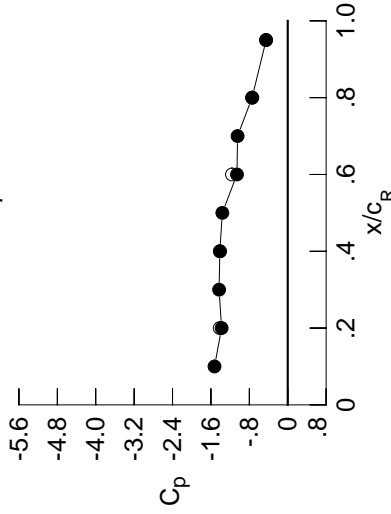

x/c_R	starb'd C_p	port C_p
0.10	-1.5253	*****
0.20	-1.3778	-1.4169
0.30	-1.4297	*****
0.40	-1.4143	-1.4103
0.50	-1.3626	*****
0.60	-1.0578	-1.1620
0.70	-1.0450	*****
0.80	-0.7429	-0.7379
0.90	*****	*****
0.95	-0.4497	-0.4534

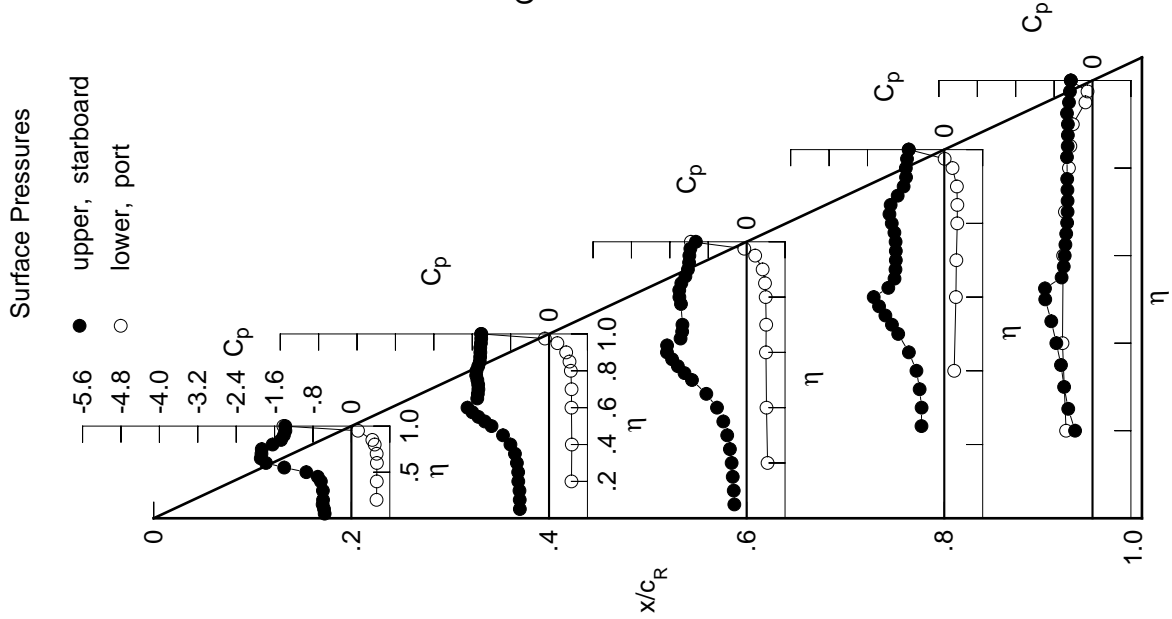

Table F1. Continued.

η	x/c_R .2	x/c_R .4	x/c_R .6	x/c_R .8	x/c_R .95
	$C_{p,u}$	$C_{p,u}$	$C_{p,u}$	$C_{p,u}$	$C_{p,u}$
0.050	-0.6291	-0.6546	-0.1130	*****	*****
0.100	-0.6251	-0.6555	-0.1271	*****	*****
0.150	-0.6517	-0.6680	-0.1449	*****	*****
0.200	-0.6683	-0.6780	-0.1737	*****	-0.4475
0.250	*****	-0.7079	-0.2128	-0.7284	-0.5551
0.300	-0.6900	-0.7494	-0.2782	-0.7606	-0.6466
0.350	*****	-0.8281	-0.3826	-0.8375	-0.7150
0.400	-0.7953	-0.9674	-0.5498	-0.8968	-0.7748
0.450	-0.9770	-1.1655	-0.7843	-0.9880	-0.7751
0.500	-1.3231	-1.3950	-1.0917	-1.0384	-0.7430
0.525	*****	-1.5161	-1.2434	-1.0473	-0.7560
0.550	-1.6694	-1.6242	-1.3772	-1.0374	-0.7496
0.575	*****	-1.7166	-1.4960	-1.0494	-0.7593
0.600	-1.8977	-1.7863	-1.4957	-1.0561	-0.7491
0.625	*****	*****	-1.2444	-1.0469	-0.7357
0.650	-1.8763	-1.5786	-1.1605	-1.0069	-0.7121
0.675	*****	-1.5635	-1.1341	-0.9765	-0.6833
0.700	-1.8401	-1.5513	-1.1163	-0.9503	-0.6635
0.725	*****	-1.5437	*****	-0.9250	-0.6420
0.750	-1.8194	-1.5534	*****	-0.9020	-0.6238
0.775	*****	-1.5690	-1.0767	-0.8919	-0.6071
0.800	-1.6246	-1.5821	-1.0674	-0.8862	*****
0.825	*****	-1.5448	-1.0768	-0.8820	-0.5936
0.850	-1.5041	-1.5018	-1.0675	-0.8829	-0.5775
0.875	*****	-1.4711	-1.0020	-0.8771	-0.5546
0.900	-1.4691	-1.4674	-0.9176	-0.8627	-0.5335
0.925	*****	-1.4670	-0.8552	-0.8378	-0.5165
0.950	-1.4419	-1.4566	-0.8403	-0.8332	-0.4822
0.975	*****	-1.4534	-0.8343	-0.8246	-0.4526
1.000	-1.4440	-1.4530	-0.7625	-0.8121	-0.4422
	$C_{p,l}$	$C_{p,l}$	$C_{p,l}$	$C_{p,l}$	$C_{p,l}$
-0.200	0.5742	0.5071	0.4709	*****	-0.5768
-0.400	0.5777	0.5134	0.4456	0.2291	-0.6402
-0.600	0.5728	0.5058	0.4367	0.2585	-0.6121
-0.700	0.5618	0.5055	0.4368	0.2690	-0.5725
-0.800	0.5080	0.4845	0.4295	0.2846	-0.4872
-0.850	0.4507	0.4465	0.4121	0.2807	-0.4588
-0.900	*****	0.3625	0.3574	0.2653	-0.4037
-0.950	0.1136	0.1562	0.1933	0.1594	-0.1505
-0.975	*****	-0.1230	-0.0332	-0.0139	-0.1201
-1.000	-1.5018	-1.4682	-0.7970	-0.8047	-0.4453

Medium Radius L.E.

Run No. = 5, Point No. = 102

$C_N = 1.113$, $C_m = -0.1827$

$\alpha = 24.6^\circ$, $M_\infty = 0.799$

$R_{mac} = 5.9 \times 10^6$

Leading Edge Pressures

● starboard
○ port

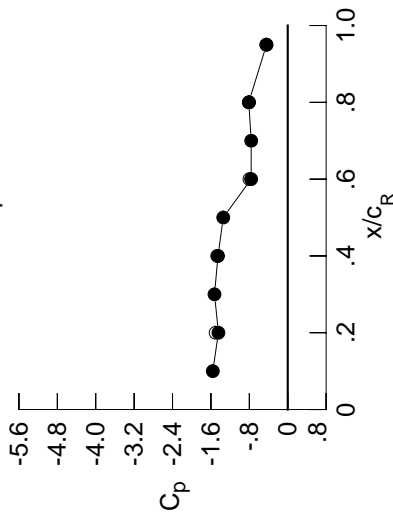

x/c_R	starb'd C_p	port C_p
0.10	-1.5609	*****
0.20	-1.4440	-1.5018
0.30	-1.5255	*****
0.40	-1.4530	-1.4682
0.50	-1.3430	*****
0.60	-0.7625	-0.7970
0.70	-0.7609	*****
0.80	-0.8121	-0.8047
0.90	*****	*****
0.95	-0.4422	-0.4453

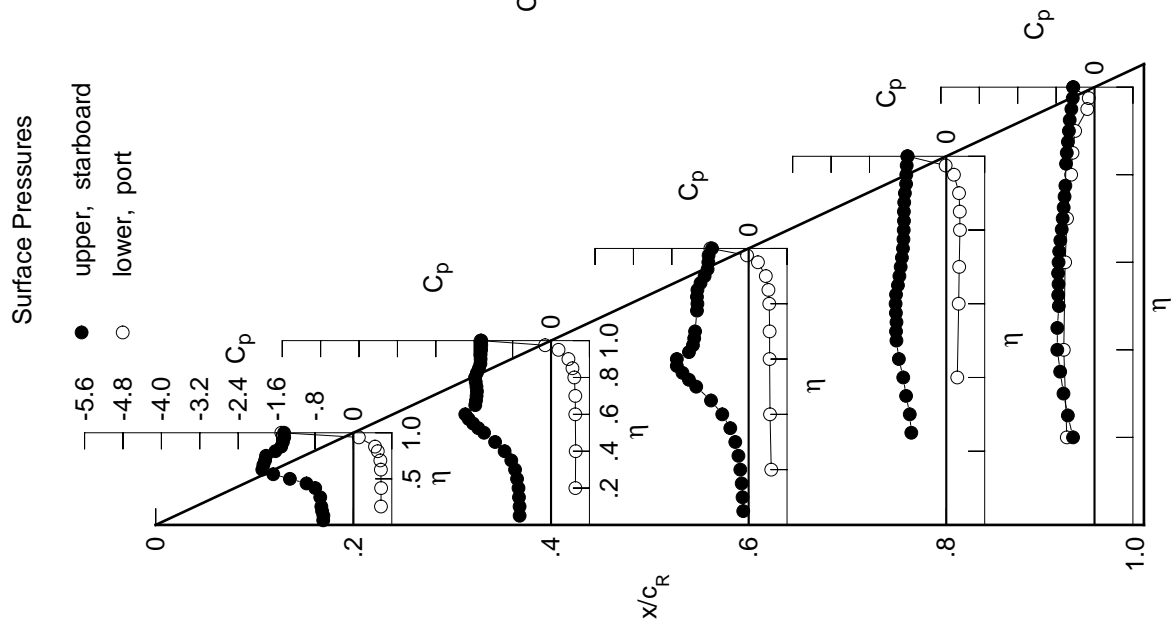

Table F1. Concluded.

η	$x/c_R = .2$		$x/c_R = .4$		$x/c_R = .6$		$x/c_R = .8$		$x/c_R = .95$	
	$C_{p,u}$	$C_{p,u}$	$C_{p,u}$	$C_{p,u}$	$C_{p,u}$	$C_{p,u}$	$C_{p,u}$	$C_{p,u}$	$C_{p,u}$	$C_{p,u}$
0.050	-0.7283	-0.7276	-0.1241	*****	*****	*****	*****	*****	*****	*****
0.100	-0.7321	-0.7344	-0.1375	*****	*****	*****	*****	*****	*****	*****
0.150	-0.7538	-0.7481	-0.1564	*****	*****	*****	*****	*****	*****	*****
0.200	-0.7560	-0.7645	-0.1850	*****	*****	*****	*****	*****	*****	-0.5816
0.250	*****	-0.8090	-0.2287	-0.9975	-0.9975	-0.9975	-0.9975	-0.9975	-0.9975	-0.6971
0.300	-0.8132	-0.8758	-0.3071	-0.9984	-0.9984	-0.9984	-0.9984	-0.9984	-0.9984	-0.7627
0.350	*****	-0.9847	-0.4304	-1.0037	-1.0037	-1.0037	-1.0037	-1.0037	-1.0037	-0.7662
0.400	-1.0490	-1.1486	-0.6205	-0.9814	-0.9814	-0.9814	-0.9814	-0.9814	-0.9814	-0.7537
0.450	-1.3080	-1.3541	-0.8538	-0.9802	-0.9802	-0.9802	-0.9802	-0.9802	-0.9802	-0.7513
0.500	-1.6127	-1.5557	-1.1415	-0.9777	-0.9777	-0.9777	-0.9777	-0.9777	-0.9777	-0.7515
0.525	*****	-1.6547	-1.2758	-0.9931	-0.9931	-0.9931	-0.9931	-0.9931	-0.9931	-0.7759
0.550	-1.8395	-1.7368	-1.3849	-1.0014	-1.0014	-1.0014	-1.0014	-1.0014	-1.0014	-0.7744
0.575	*****	-1.8095	-1.4647	-1.0322	-1.0322	-1.0322	-1.0322	-1.0322	-1.0322	-0.7887
0.600	-1.8805	-1.8394	-1.3616	-1.0441	-1.0441	-1.0441	-1.0441	-1.0441	-1.0441	-0.7810
0.625	*****	*****	-1.1678	-1.0397	-1.0397	-1.0397	-1.0397	-1.0397	-1.0397	-0.7725
0.650	-1.8159	-1.6475	-1.0990	-1.0267	-1.0267	-1.0267	-1.0267	-1.0267	-1.0267	-0.7555
0.675	*****	-1.6374	-1.0769	-1.0162	-1.0162	-1.0162	-1.0162	-1.0162	-1.0162	-0.7305
0.700	-1.8172	-1.6236	-1.0626	-1.0053	-1.0053	-1.0053	-1.0053	-1.0053	-1.0053	-0.7167
0.725	*****	-1.6177	*****	-0.9863	-0.9863	-0.9863	-0.9863	-0.9863	-0.9863	-0.6980
0.750	-1.8419	-1.6229	*****	-0.9677	-0.9677	-0.9677	-0.9677	-0.9677	-0.9677	-0.6822
0.775	*****	-1.6361	-1.0008	-0.9578	-0.9578	-0.9578	-0.9578	-0.9578	-0.9578	-0.6584
0.800	-1.7328	-1.6506	-0.9877	-0.9521	*****	*****	*****	*****	*****	*****
0.825	*****	-1.6174	-0.9775	-0.9459	-0.9459	-0.9459	-0.9459	-0.9459	-0.9459	-0.6355
0.850	-1.5605	-1.5761	-0.9646	-0.9368	-0.9368	-0.9368	-0.9368	-0.9368	-0.9368	-0.6173
0.875	*****	-1.5445	-0.9353	-0.9268	-0.9268	-0.9268	-0.9268	-0.9268	-0.9268	-0.6015
0.900	-1.5307	-1.5394	-0.8949	-0.9124	-0.9124	-0.9124	-0.9124	-0.9124	-0.9124	-0.5839
0.925	*****	-1.5413	-0.8591	-0.8849	-0.8849	-0.8849	-0.8849	-0.8849	-0.8849	-0.5681
0.950	-1.5231	-1.5366	-0.8481	-0.8757	-0.8757	-0.8757	-0.8757	-0.8757	-0.8757	-0.5333
0.975	*****	-1.5316	-0.8500	-0.8526	-0.8526	-0.8526	-0.8526	-0.8526	-0.8526	-0.4935
1.000	-1.5385	-1.5343	-0.7778	-0.8273	-0.8273	-0.8273	-0.8273	-0.8273	-0.8273	-0.4622
-0.200	$C_{p,l}$	$C_{p,l}$	$C_{p,l}$	$C_{p,l}$	$C_{p,l}$	$C_{p,l}$	$C_{p,l}$	$C_{p,l}$	$C_{p,l}$	$C_{p,l}$
-0.400	0.6283	0.5547	0.5074	*****	*****	*****	*****	*****	*****	-0.5374
-0.600	0.6279	0.5613	0.4833	0.2641	0.2641	0.2641	0.2641	0.2641	0.2641	-0.6080
-0.700	0.6184	0.5490	0.4706	0.2909	0.2909	0.2909	0.2909	0.2909	0.2909	-0.5812
-0.800	0.5982	0.5427	0.4700	0.2942	0.2942	0.2942	0.2942	0.2942	0.2942	-0.5477
-0.850	0.5313	0.5114	0.4535	0.3077	0.3077	0.3077	0.3077	0.3077	0.3077	-0.4589
-0.900	0.4635	0.4674	0.4297	0.3006	0.3006	0.3006	0.3006	0.3006	0.3006	-0.4317
-0.950	0.0887	0.1376	0.1774	0.2729	0.2729	0.2729	0.2729	0.2729	0.2729	-0.3764
-0.975	*****	-0.1636	-0.0652	-0.0508	-0.0508	-0.0508	-0.0508	-0.0508	-0.0508	-0.1432
-1.000	-1.6765	-1.5343	-0.8279	-0.8086	-0.8086	-0.8086	-0.8086	-0.8086	-0.8086	-0.4834

Medium Radius L.E.
 Run No. = 5, Point No. = 103
 $C_N = 1.207$, $C_m = -0.1975$
 $\alpha = 26.6^\circ$, $M_\infty = 0.799$
 $R_{mac} = 5.9 \times 10^6$

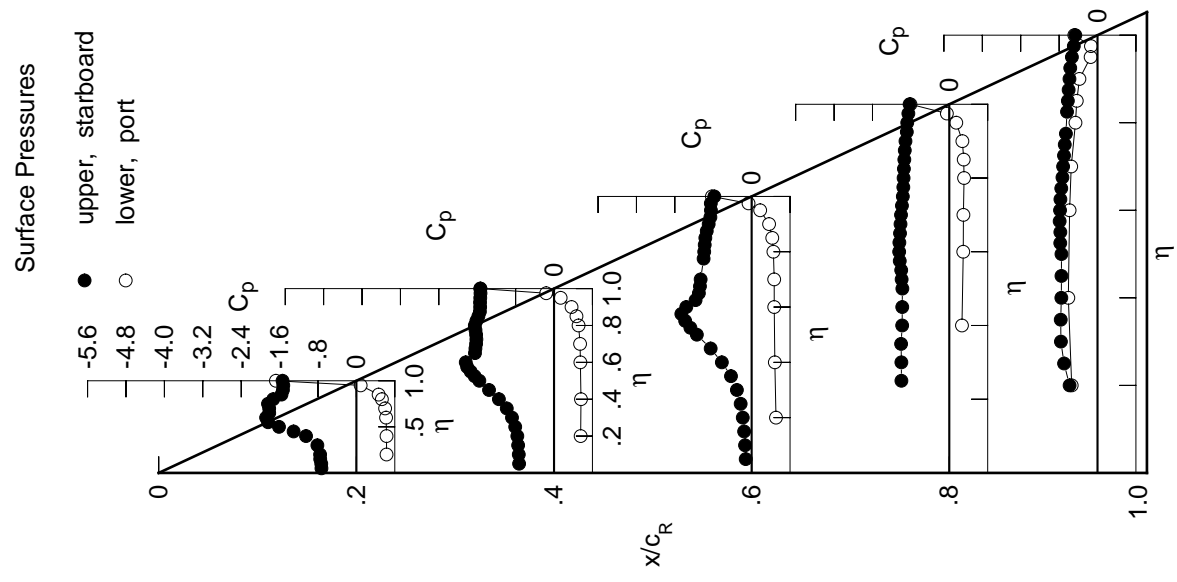
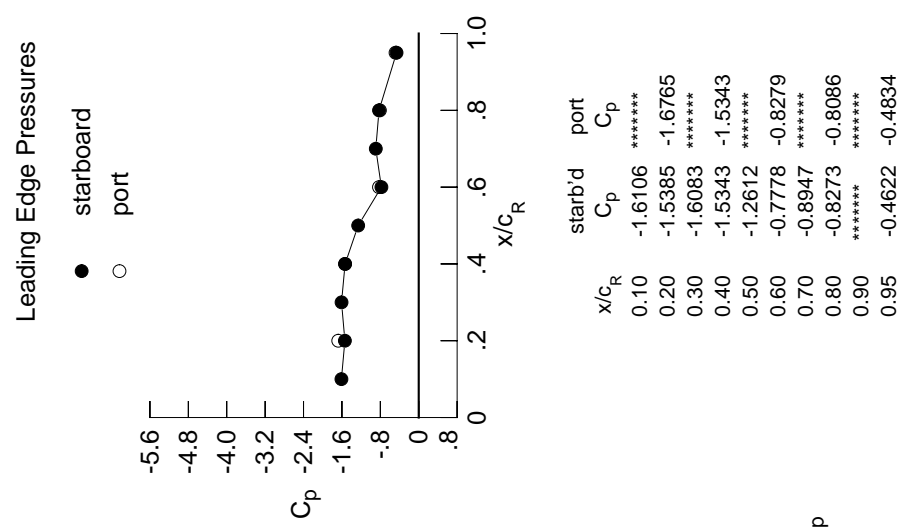
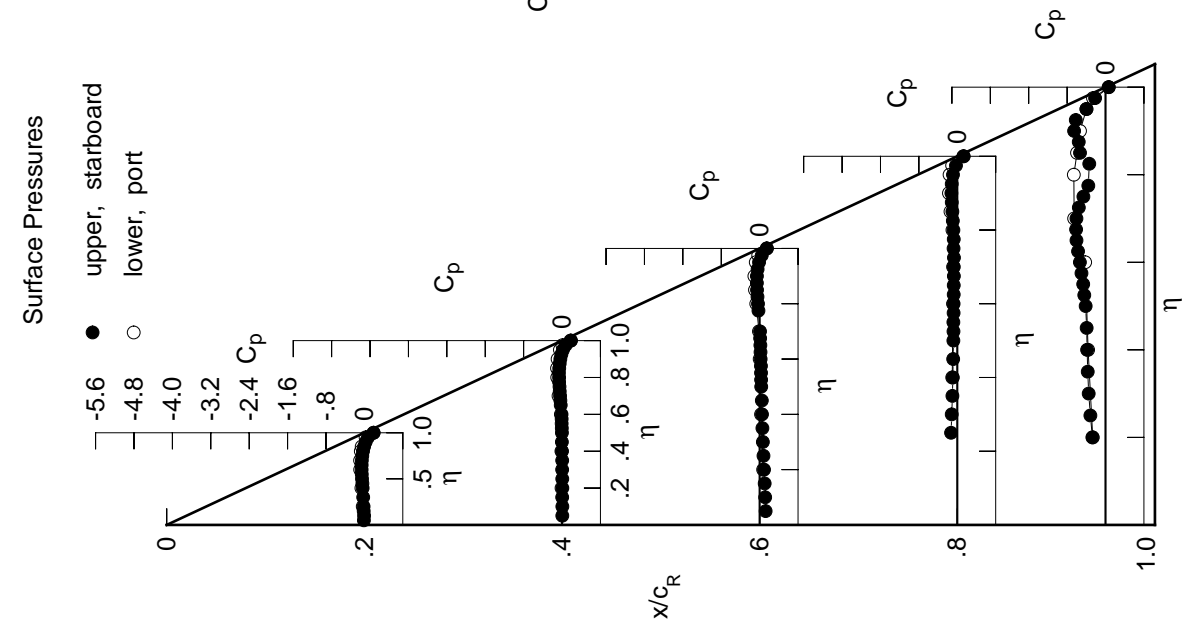

Table F2. Tabulations and Plots of Surface Pressure Coefficients.

η	x/c_R .2	x/c_R .4	x/c_R .6	x/c_R .8	x/c_R .95
	$C_{p,u}$	$C_{p,u}$	$C_{p,u}$	$C_{p,u}$	$C_{p,u}$
0.050	-0.0107	0.0054	0.1245	*****	*****
0.100	-0.0062	0.0061	0.1152	*****	*****
0.150	-0.0143	0.0035	0.1049	*****	*****
0.200	-0.0168	0.0065	0.0910	*****	-0.2735
0.250	*****	0.0048	0.0799	-0.1294	-0.3149
0.300	-0.0251	0.0025	0.0670	-0.1158	-0.3500
0.350	*****	0.0030	0.0576	-0.1012	-0.3705
0.400	-0.0366	-0.0009	0.0484	-0.0927	-0.3828
0.450	-0.0415	-0.0033	0.0456	-0.0857	-0.3931
0.500	-0.0498	-0.0028	0.0332	-0.0816	-0.4138
0.525	*****	-0.0049	0.0303	-0.0791	-0.4428
0.550	-0.0543	-0.0080	0.0292	-0.0812	-0.4647
0.575	*****	-0.0079	0.0272	-0.0766	-0.5008
0.600	-0.0575	-0.0100	0.0209	-0.0768	-0.5337
0.625	*****	*****	0.0185	-0.0747	-0.5717
0.650	-0.0569	-0.0275	0.0154	-0.0735	-0.6045
0.675	*****	-0.0341	0.0102	-0.0714	-0.6129
0.700	-0.0534	-0.0404	0.0080	-0.0728	-0.6058
0.725	*****	-0.0479	*****	-0.0697	-0.5560
0.750	-0.0436	-0.0531	*****	-0.0772	-0.4605
0.775	*****	-0.0609	-0.0249	-0.0735	-0.3585
0.800	-0.0290	-0.0609	-0.0344	-0.0810	*****
0.825	*****	-0.0647	-0.0449	-0.0926	-0.3382
0.850	-0.0061	-0.0585	-0.0542	-0.1025	-0.5309
0.875	*****	-0.0486	-0.0577	-0.1155	-0.5578
0.900	0.0267	-0.0355	-0.0569	-0.1235	-0.6543
0.925	*****	-0.0143	-0.0420	-0.1162	-0.6189
0.950	0.0755	0.0190	-0.0120	-0.0895	-0.3977
0.975	*****	0.0749	0.0441	-0.0269	-0.2165
1.000	0.1931	0.1868	0.1459	0.1344	0.0647
	$C_{p,l}$	$C_{p,l}$	$C_{p,l}$	$C_{p,l}$	$C_{p,l}$
-0.200	-0.0345	-0.0104	0.0726	*****	-0.2660
-0.400	-0.0625	-0.0125	0.0285	-0.1054	-0.3624
-0.600	-0.0879	-0.0240	0.0010	-0.0892	-0.4239
-0.700	-0.0892	-0.0731	-0.0142	-0.0880	-0.6533
-0.800	-0.0745	-0.1001	-0.0703	-0.1010	-0.6597
-0.850	-0.0556	-0.1043	-0.0967	-0.1416	-0.5935
-0.900	*****	-0.0922	-0.1098	-0.1734	-0.5309
-0.950	0.0251	-0.0438	-0.0810	-0.1608	-0.3968
-0.975	*****	0.0082	-0.0299	-0.1075	-0.2605
-1.000	0.1897	0.1768	0.1524	0.1256	0.0677

Medium Radius L.E.
 Run No. = 6, Point No. = 105
 $C_N = -0.015$, $C_m = -0.0040$
 $\alpha = -0.4^\circ$, $M_\infty = 0.829$
 $R_{mac} = 6.0 \times 10^6$



Leading Edge Pressures

● starboard
 ○ port

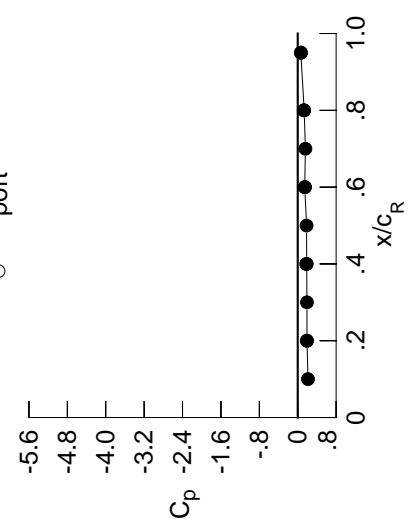

x/c_R	starb'd C_p	port C_p
0.10	0.2133	*****
0.20	0.1931	0.1897
0.30	0.1919	*****
0.40	0.1868	0.1768
0.50	0.1844	*****
0.60	0.1459	0.1524
0.70	0.1597	*****
0.80	0.1344	0.1256
0.90	*****	*****
0.95	0.0647	0.0677

Table F2. Continued.

η	$x/c_R = .2$		$x/c_R = .4$		$x/c_R = .6$		$x/c_R = .8$		$x/c_R = .95$	
	$C_{p,u}$	$C_{p,u}$	$C_{p,u}$	$C_{p,u}$	$C_{p,u}$	$C_{p,u}$	$C_{p,u}$	$C_{p,u}$	$C_{p,u}$	$C_{p,u}$
0.050	-0.0175	-0.0031	0.1209	0.1209	0.1209	0.1209	0.1209	0.1209	0.1209	0.1209
0.100	-0.0154	-0.0011	0.1133	0.1133	0.1133	0.1133	0.1133	0.1133	0.1133	0.1133
0.150	-0.0229	-0.0036	0.0992	0.0992	0.0992	0.0992	0.0992	0.0992	0.0992	0.0992
0.200	-0.0231	0.0009	0.0861	0.0861	0.0861	0.0861	0.0861	0.0861	0.0861	0.0861
0.250	*****	-0.0020	0.0744	-0.1323	-0.1323	-0.1323	-0.1323	-0.1323	-0.1323	-0.1323
0.300	-0.0308	-0.0031	0.0620	-0.1179	-0.1179	-0.1179	-0.1179	-0.1179	-0.1179	-0.1179
0.350	*****	-0.0027	0.0540	-0.1059	-0.1059	-0.1059	-0.1059	-0.1059	-0.1059	-0.1059
0.400	-0.0448	-0.0078	0.0432	-0.0956	-0.0956	-0.0956	-0.0956	-0.0956	-0.0956	-0.0956
0.450	-0.0510	-0.0080	0.0415	-0.0900	-0.0900	-0.0900	-0.0900	-0.0900	-0.0900	-0.0900
0.500	-0.0599	-0.0104	0.0264	-0.0869	-0.0869	-0.0869	-0.0869	-0.0869	-0.0869	-0.0869
0.525	*****	-0.0105	0.0265	-0.0846	-0.0846	-0.0846	-0.0846	-0.0846	-0.0846	-0.0846
0.550	-0.0649	-0.0145	0.0222	-0.0829	-0.0829	-0.0829	-0.0829	-0.0829	-0.0829	-0.0829
0.575	*****	-0.0153	0.0216	-0.0813	-0.0813	-0.0813	-0.0813	-0.0813	-0.0813	-0.0813
0.600	-0.0687	-0.0183	0.0151	-0.0807	-0.0807	-0.0807	-0.0807	-0.0807	-0.0807	-0.0807
0.625	*****	*****	0.0116	-0.0788	-0.0788	-0.0788	-0.0788	-0.0788	-0.0788	-0.0788
0.650	-0.0682	-0.0430	0.0086	-0.0779	-0.0779	-0.0779	-0.0779	-0.0779	-0.0779	-0.0779
0.675	*****	-0.0498	0.0037	-0.0781	-0.0781	-0.0781	-0.0781	-0.0781	-0.0781	-0.0781
0.700	-0.0668	-0.0525	0.0019	-0.0797	-0.0797	-0.0797	-0.0797	-0.0797	-0.0797	-0.0797
0.725	*****	-0.0617	*****	-0.0775	-0.0775	-0.0775	-0.0775	-0.0775	-0.0775	-0.0775
0.750	-0.0570	-0.0660	*****	-0.0819	-0.0819	-0.0819	-0.0819	-0.0819	-0.0819	-0.0819
0.775	*****	-0.0731	-0.0394	-0.0791	-0.0791	-0.0791	-0.0791	-0.0791	-0.0791	-0.0791
0.800	-0.0437	-0.0787	-0.0472	-0.0861	-0.0861	-0.0861	-0.0861	-0.0861	-0.0861	-0.0861
0.825	*****	-0.0767	-0.0551	-0.1041	-0.1041	-0.1041	-0.1041	-0.1041	-0.1041	-0.1041
0.850	-0.0215	-0.0777	-0.0697	-0.1151	-0.1151	-0.1151	-0.1151	-0.1151	-0.1151	-0.1151
0.875	*****	-0.0684	-0.0730	-0.1295	-0.1295	-0.1295	-0.1295	-0.1295	-0.1295	-0.1295
0.900	0.0100	-0.0577	-0.0751	-0.1409	-0.1409	-0.1409	-0.1409	-0.1409	-0.1409	-0.1409
0.925	*****	-0.0370	-0.0608	-0.1353	-0.1353	-0.1353	-0.1353	-0.1353	-0.1353	-0.1353
0.950	0.0586	0.0009	-0.0365	-0.1138	-0.1138	-0.1138	-0.1138	-0.1138	-0.1138	-0.1138
0.975	*****	0.0526	0.0194	-0.0510	-0.2344	-0.2344	-0.2344	-0.2344	-0.2344	-0.2344
1.000	0.1966	0.1915	0.1548	0.1408	0.1408	0.1408	0.1408	0.1408	0.1408	0.1408
$C_{p,l}$	$C_{p,l}$	$C_{p,l}$	$C_{p,l}$	$C_{p,l}$	$C_{p,l}$	$C_{p,l}$	$C_{p,l}$	$C_{p,l}$	$C_{p,l}$	$C_{p,l}$
-0.200	-0.0267	-0.0049	0.0787	*****	-0.2694	-0.2694	-0.2694	-0.2694	-0.2694	-0.2694
-0.400	-0.0528	-0.0064	0.0347	-0.0997	-0.3732	-0.3732	-0.3732	-0.3732	-0.3732	-0.3732
-0.600	-0.0759	-0.0151	0.0097	-0.0818	-0.4159	-0.4159	-0.4159	-0.4159	-0.4159	-0.4159
-0.700	-0.0740	-0.0582	-0.0043	-0.0798	-0.6437	-0.6437	-0.6437	-0.6437	-0.6437	-0.6437
-0.800	-0.0579	-0.0842	-0.0552	-0.0879	-0.6743	-0.6743	-0.6743	-0.6743	-0.6743	-0.6743
-0.850	-0.0380	-0.0855	-0.0803	-0.1253	-0.6138	-0.6138	-0.6138	-0.6138	-0.6138	-0.6138
-0.900	*****	-0.0700	-0.0887	-0.1536	-0.5543	-0.5543	-0.5543	-0.5543	-0.5543	-0.5543
-0.950	0.0455	-0.0177	-0.0532	-0.1330	-0.3863	-0.3863	-0.3863	-0.3863	-0.3863	-0.3863
-0.975	*****	0.0360	0.0001	-0.0749	-0.2402	-0.2402	-0.2402	-0.2402	-0.2402	-0.2402
-1.000	0.1971	0.1863	0.1654	0.1393	0.0781	0.0781	0.0781	0.0781	0.0781	0.0781

Medium Radius L.E.
 Run No. = 6, Point No. = 106
 $C_N = -0.001$, $C_m = -0.0045$
 $\alpha = 0.0^\circ$, $M_\infty = 0.829$
 $R_{mac} = 6.0 \times 10^6$

Leading Edge Pressures

- starboard
- port

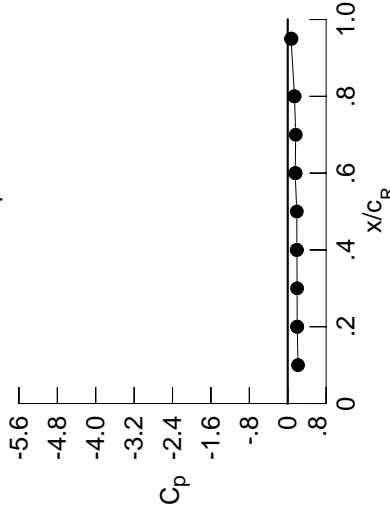

x/c_R	starb'd C_p	port C_p
0.10	0.2148	*****
0.20	0.1966	0.1971
0.30	0.1950	*****
0.40	0.1915	0.1863
0.50	0.1888	*****
0.60	0.1548	0.1654
0.70	0.1661	*****
0.80	0.1408	0.1393
0.90	*****	*****
0.95	0.0695	0.0781

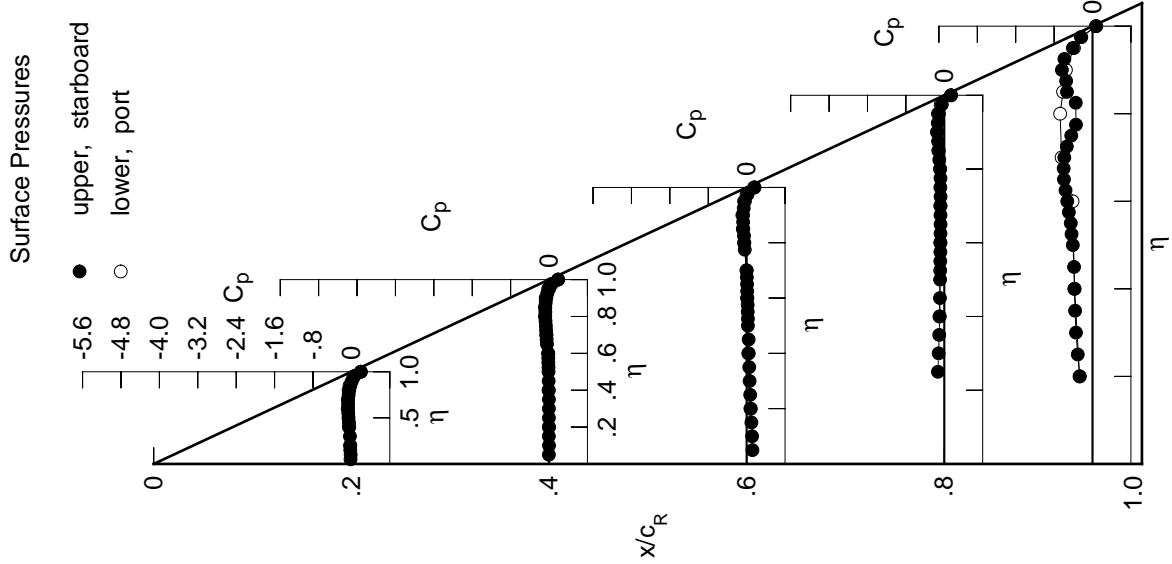

Table F2. Continued.

η	$x/c_R = .2$		$x/c_R = .4$		$x/c_R = .6$		$x/c_R = .8$		$x/c_R = .95$	
	$C_{p,u}$	$C_{p,l}$	$C_{p,u}$	$C_{p,l}$	$C_{p,u}$	$C_{p,l}$	$C_{p,u}$	$C_{p,l}$	$C_{p,u}$	$C_{p,l}$
0.050	-0.0354	-0.0189	0.1099	*****	*****	*****	*****	*****	*****	*****
0.100	-0.0352	-0.0192	0.0998	*****	*****	*****	*****	*****	*****	*****
0.150	-0.0396	-0.0213	0.0878	*****	*****	*****	*****	*****	*****	*****
0.200	-0.0447	-0.0159	0.0720	*****	*****	*****	*****	*****	*****	*****
0.250	*****	-0.0185	0.0621	-0.1443	-0.2985	*****	*****	*****	*****	*****
0.300	-0.0515	-0.0215	0.0475	-0.1290	-0.3311	*****	*****	*****	*****	*****
0.350	*****	-0.0213	0.0376	-0.1181	-0.3474	*****	*****	*****	*****	*****
0.400	-0.0712	-0.0245	0.0294	-0.1110	-0.3540	*****	*****	*****	*****	*****
0.450	-0.0800	-0.0295	0.0241	-0.1025	-0.3606	*****	*****	*****	*****	*****
0.500	-0.0868	-0.0277	0.0110	-0.1009	-0.3766	*****	*****	*****	*****	*****
0.525	*****	-0.0308	0.0082	-0.0995	-0.3959	*****	*****	*****	*****	*****
0.550	-0.0925	-0.0354	0.0068	-0.0982	-0.4067	*****	*****	*****	*****	*****
0.575	*****	-0.0325	0.0047	-0.0978	-0.4323	*****	*****	*****	*****	*****
0.600	-0.0982	-0.0298	-0.0042	-0.0975	-0.4565	*****	*****	*****	*****	*****
0.625	*****	*****	-0.0059	-0.0969	-0.4940	*****	*****	*****	*****	*****
0.650	-0.1009	-0.0772	-0.0092	-0.0977	-0.5449	*****	*****	*****	*****	*****
0.675	*****	-0.0852	-0.0158	-0.0946	-0.5854	*****	*****	*****	*****	*****
0.700	-0.1033	-0.0881	-0.0174	-0.0994	-0.6138	*****	*****	*****	*****	*****
0.725	*****	-0.0941	*****	-0.0962	-0.6114	*****	*****	*****	*****	*****
0.750	-0.0959	-0.1012	*****	-0.1055	-0.5748	*****	*****	*****	*****	*****
0.775	*****	-0.1115	-0.0775	-0.1029	-0.4966	*****	*****	*****	*****	*****
0.800	-0.0852	-0.1177	-0.0945	-0.1005	*****	*****	*****	*****	*****	*****
0.825	*****	-0.1245	-0.0989	-0.1481	-0.5080	*****	*****	*****	*****	*****
0.850	-0.0650	-0.1233	-0.1125	-0.1546	-0.5656	*****	*****	*****	*****	*****
0.875	*****	-0.1200	-0.1227	-0.1697	-0.5826	*****	*****	*****	*****	*****
0.900	-0.0367	-0.1121	-0.1306	-0.1874	-0.6307	*****	*****	*****	*****	*****
0.925	*****	-0.0950	-0.1217	-0.1933	-0.5965	*****	*****	*****	*****	*****
0.950	0.0080	-0.0646	-0.1042	-0.1803	-0.4507	*****	*****	*****	*****	*****
0.975	*****	-0.0176	-0.0568	-0.1313	-0.2986	*****	*****	*****	*****	*****
1.000	0.1823	0.1705	0.1336	0.1136	0.0487	*****	*****	*****	*****	*****
	$C_{p,l}$	$C_{p,l}$	$C_{p,l}$	$C_{p,l}$	$C_{p,l}$	$C_{p,l}$	$C_{p,l}$	$C_{p,l}$	$C_{p,l}$	$C_{p,l}$
-0.200	-0.0060	0.0147	0.0914	*****	-0.2812	*****	*****	*****	*****	*****
-0.400	-0.0301	0.0120	0.0491	-0.0874	-0.3888	*****	*****	*****	*****	*****
-0.600	-0.0461	0.0019	0.0259	-0.0663	-0.5066	*****	*****	*****	*****	*****
-0.700	-0.0412	-0.0283	0.0135	-0.0639	-0.6476	*****	*****	*****	*****	*****
-0.800	-0.0189	-0.0454	-0.0222	-0.0628	-0.7261	*****	*****	*****	*****	*****
-0.850	0.0044	-0.0404	-0.0415	-0.0930	-0.6870	*****	*****	*****	*****	*****
-0.900	*****	-0.0188	-0.0385	-0.1088	-0.6333	*****	*****	*****	*****	*****
-0.950	0.0916	0.0390	0.0085	-0.0708	-0.3656	*****	*****	*****	*****	*****
-0.975	*****	0.0948	0.0652	-0.0078	-0.1948	*****	*****	*****	*****	*****
-1.000	0.1900	0.1749	0.1502	0.1298	0.0703	*****	*****	*****	*****	*****

Medium Radius L.E.

Run No. = 6, Point No. = 107

$C_N = 0.038$, $C_m = -0.0096$

$\alpha = 1.1^\circ$, $M_\infty = 0.829$

$R_{mac} = 6.0 \times 10^6$

Leading Edge Pressures

- starboard
- port

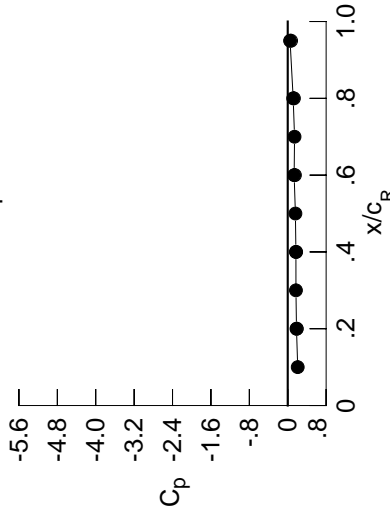

x/c_R	starb'd C_p	port C_p
0.10	0.2080	*****
0.20	0.1823	0.1900
0.30	0.1712	*****
0.40	0.1705	0.1749
0.50	0.1597	*****
0.60	0.1336	0.1502
0.70	0.1420	*****
0.80	0.1136	0.1298
0.90	*****	*****
0.95	0.0487	0.0703

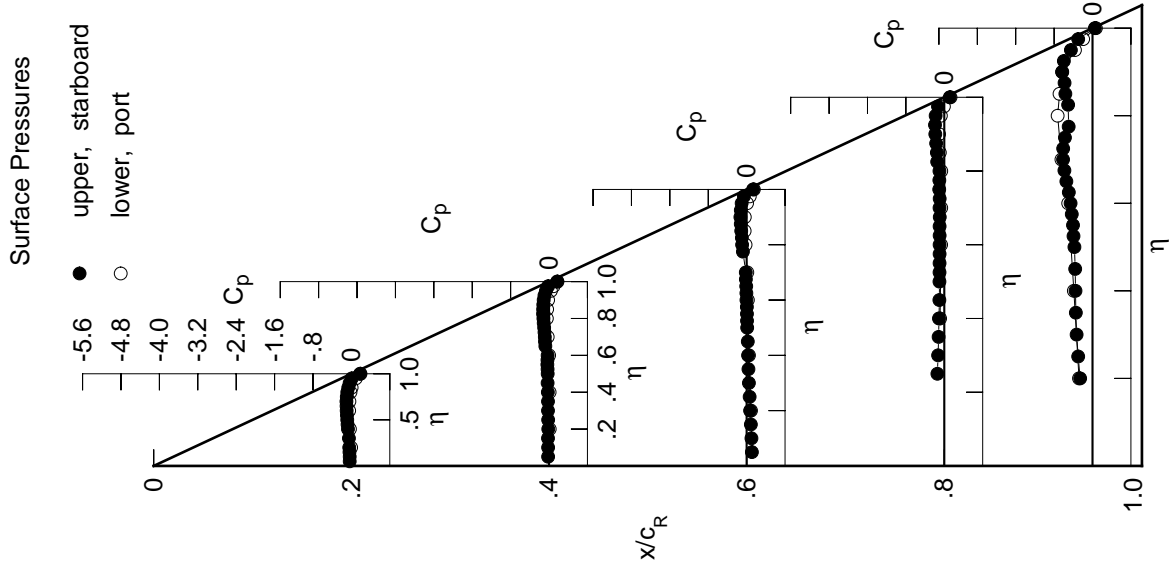

Table F2. Continued.

η	x/c_R .2	$C_{p,u}$	x/c_R .4	$C_{p,u}$	x/c_R .6	$C_{p,u}$	x/c_R .8	$C_{p,u}$	x/c_R .95	$C_{p,u}$
0.050		-0.0520		-0.0375		0.0931		0.0931		*****
0.100		-0.0539		-0.0330		0.0876		0.0876		*****
0.150		-0.0589		-0.0400		0.0718		0.0718		*****
0.200		-0.0619		-0.0325		0.0614		0.0614		*****
0.250		*****		-0.0380		0.0473		-0.1566		-0.2466
0.300		-0.0727		-0.0386		0.0369		-0.1427		-0.2859
0.350		*****		-0.0416		0.0243		-0.1319		-0.3419
0.400		-0.0909		-0.0452		0.0148		-0.1217		-0.3574
0.450		-0.0990		-0.0499		0.0095		-0.1163		-0.3562
0.500		-0.1102		-0.0538		-0.0044		-0.1121		-0.3657
0.525		*****		-0.0564		-0.0098		-0.1139		-0.3746
0.550		-0.1180		-0.0608		-0.0137		-0.1121		-0.3775
0.575		*****		-0.0653		-0.0152		-0.1127		-0.3899
0.600		-0.1266		-0.0646		-0.0251		-0.1138		-0.3963
0.625		*****		*****		-0.0280		-0.1120		-0.4044
0.650		-0.1322		-0.0827		-0.0318		-0.1146		-0.4122
0.675		*****		-0.0993		-0.0420		-0.1166		-0.4118
0.700		-0.1379		-0.1105		-0.0478		-0.1162		-0.4026
0.725		*****		-0.1219		*****		-0.1200		-0.3836
0.750		-0.1330		-0.1357		*****		-0.1316		-0.3415
0.775		*****		-0.1478		-0.0855		-0.1303		-0.2838
0.800		-0.1266		-0.1592		-0.1101		-0.1407		*****
0.825		*****		-0.1659		-0.1302		-0.1513		-0.3040
0.850		-0.1112		-0.1707		-0.1519		-0.1823		-0.3743
0.875		*****		-0.1736		-0.1696		-0.2094		-0.5331
0.900		-0.0874		-0.1694		-0.1835		-0.2371		-0.7829
0.925		*****		-0.1591		-0.1866		-0.2510		-0.9855
0.950		-0.0488		-0.1345		-0.1783		-0.2516		-0.5077
0.975		*****		-0.1005		-0.1451		-0.2187		-0.3723
1.000		0.1421		0.1020		0.0643		0.0155		-0.0322
-0.200		$C_{p,l}$		0.0304		0.1020		*****		-0.2933
-0.400		-0.0044		0.0310		0.0634		-0.0748		-0.4053
-0.600		-0.0167		0.0218		0.0428		-0.0564		-0.5439
-0.700		-0.0081		0.0033		0.0315		-0.0482		-0.6676
-0.800		0.0182		-0.0099		0.0112		-0.0442		-0.7093
-0.850		0.0435		0.0004		-0.0039		-0.0554		-0.7362
-0.900		*****		0.0284		0.0076		-0.0674		-0.7545
-0.950		0.1305		0.0868		0.0596		-0.0184		-0.3439
-0.975		*****		0.1398		0.1165		0.0468		-0.1602
-1.000		0.1557		0.1150		0.0662		0.0462		0.0121

Medium Radius L.E.
 Run No. = 6, Point No. = 108
 $C_N = 0.082$, $C_m = -0.0187$
 $\alpha = 2.1^\circ$, $M_\infty = 0.829$
 $R_{mac} = 6.0 \times 10^6$

Leading Edge Pressures

● starboard
 ○ port

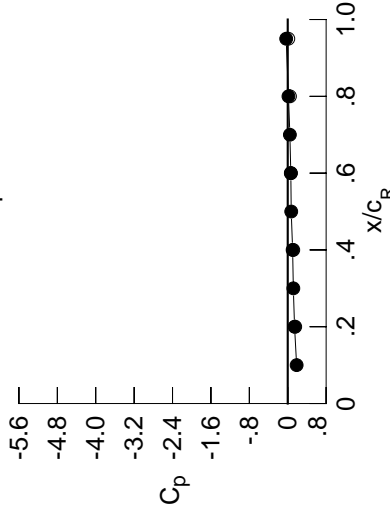

x/c_R	starb'd C_p	port C_p
0.10	0.1852	*****
0.20	0.1421	0.1557
0.30	0.1167	*****
0.40	0.1020	0.1150
0.50	0.0727	*****
0.60	0.0643	0.0662
0.70	0.0446	*****
0.80	0.0155	0.0462
0.90	*****	*****
0.95	-0.0322	0.0121

Surface Pressures

● upper, starboard
 ○ lower, port

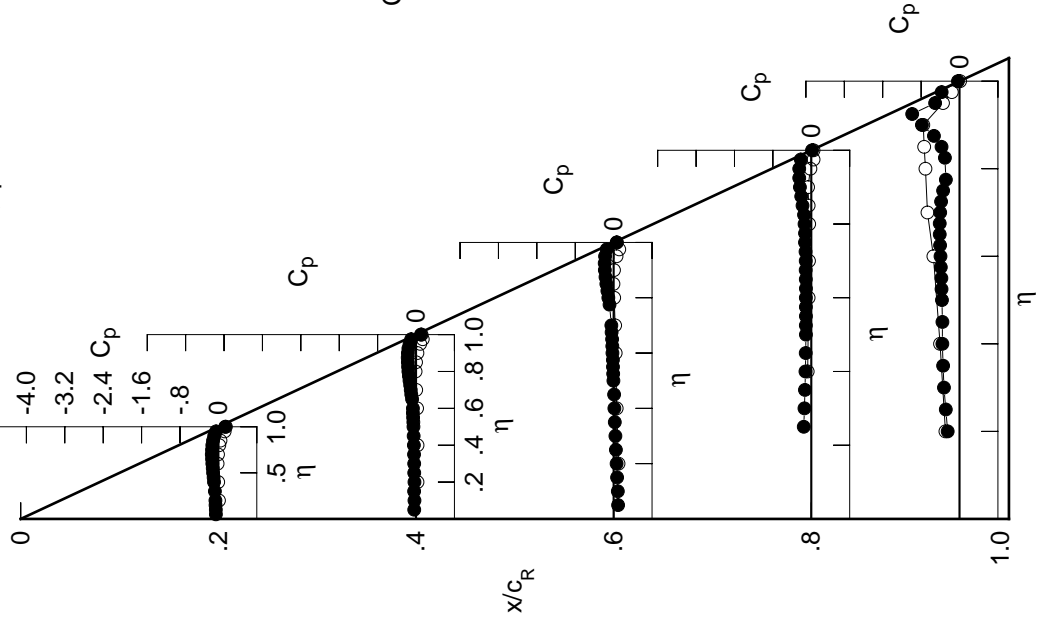

Table F2. Continued.

η	$x/c_R = .2$		$x/c_R = .4$		$x/c_R = .6$		$x/c_R = .8$		$x/c_R = .95$	
	$C_{p,u}$	$C_{p,l}$	$C_{p,u}$	$C_{p,l}$	$C_{p,u}$	$C_{p,l}$	$C_{p,u}$	$C_{p,l}$	$C_{p,u}$	$C_{p,l}$
0.050	-0.0723	-0.0520	0.0833	*****	*****	*****	*****	*****	*****	*****
0.100	-0.0737	-0.0523	0.0730	*****	*****	*****	*****	*****	*****	*****
0.150	-0.0777	-0.0581	0.0618	*****	*****	*****	*****	*****	*****	*****
0.200	-0.0806	-0.0504	0.0472	*****	*****	*****	*****	*****	*****	*****
0.250	*****	-0.0560	0.0369	-0.1655	-0.2789	*****	*****	*****	*****	*****
0.300	-0.0900	-0.0564	0.0209	-0.1525	-0.2998	*****	*****	*****	*****	*****
0.350	*****	-0.0639	0.0076	-0.1388	-0.3176	*****	*****	*****	*****	*****
0.400	-0.1100	-0.0634	-0.0004	-0.1335	-0.3305	*****	*****	*****	*****	*****
0.450	-0.1230	-0.0733	-0.0081	-0.1268	-0.3354	*****	*****	*****	*****	*****
0.500	-0.1338	-0.0746	-0.0224	-0.1260	-0.3390	*****	*****	*****	*****	*****
0.525	*****	-0.0794	-0.0271	-0.1270	-0.3453	*****	*****	*****	*****	*****
0.550	-0.1418	-0.0866	-0.0327	-0.1242	-0.3466	*****	*****	*****	*****	*****
0.575	*****	-0.0900	-0.0361	-0.1293	-0.3525	*****	*****	*****	*****	*****
0.600	-0.1530	-0.0932	-0.0464	-0.1256	-0.3573	*****	*****	*****	*****	*****
0.625	*****	*****	-0.0482	-0.1298	-0.3621	*****	*****	*****	*****	*****
0.650	-0.1614	-0.1052	-0.0551	-0.1315	-0.3645	*****	*****	*****	*****	*****
0.675	*****	-0.1236	-0.0657	-0.1330	-0.3572	*****	*****	*****	*****	*****
0.700	-0.1701	-0.1358	-0.0736	-0.1375	-0.3463	*****	*****	*****	*****	*****
0.725	*****	-0.1524	*****	-0.1408	-0.3223	*****	*****	*****	*****	*****
0.750	-0.1683	-0.1641	*****	-0.1509	-0.2643	*****	*****	*****	*****	*****
0.775	*****	-0.1853	-0.1166	-0.1580	-0.1971	*****	*****	*****	*****	*****
0.800	-0.1641	-0.1968	-0.1364	-0.1686	*****	*****	*****	*****	*****	*****
0.825	*****	-0.2097	-0.1667	-0.1803	-0.2088	*****	*****	*****	*****	*****
0.850	-0.1538	-0.2204	-0.1915	-0.2137	-0.2399	*****	*****	*****	*****	*****
0.875	*****	-0.2266	-0.2198	-0.2510	-0.3703	*****	*****	*****	*****	*****
0.900	-0.1364	-0.2306	-0.2412	-0.2867	-0.7215	*****	*****	*****	*****	*****
0.925	*****	-0.2246	-0.2541	-0.3153	-1.1956	*****	*****	*****	*****	*****
0.950	-0.1102	-0.2099	-0.2605	-0.3295	-0.5481	*****	*****	*****	*****	*****
0.975	*****	-0.1937	-0.2450	-0.3190	-0.4476	*****	*****	*****	*****	*****
1.000	0.0768	-0.0126	-0.0416	-0.1474	-0.1484	*****	*****	*****	*****	*****
-0.200	0.0338	0.0477	0.1148	*****	-0.3068	*****	*****	*****	*****	*****
-0.400	0.0220	0.0496	0.0800	-0.0631	-0.4255	*****	*****	*****	*****	*****
-0.600	0.0116	0.0454	0.0602	-0.0388	-0.5834	*****	*****	*****	*****	*****
-0.700	0.0246	0.0292	0.0532	-0.0290	-0.6766	*****	*****	*****	*****	*****
-0.800	0.0535	0.0256	0.0382	-0.0255	-0.6923	*****	*****	*****	*****	*****
-0.850	0.0792	0.0392	0.0322	-0.0303	-0.7153	*****	*****	*****	*****	*****
-0.900	*****	0.0697	0.0470	-0.0252	-0.7377	*****	*****	*****	*****	*****
-0.950	0.1627	0.1270	0.1032	0.0258	-0.3167	*****	*****	*****	*****	*****
-0.975	*****	0.1734	0.1534	0.0886	-0.1219	*****	*****	*****	*****	*****
-1.000	0.0909	0.0067	-0.0842	-0.1051	-0.0838	*****	*****	*****	*****	*****

Medium Radius L.E.
 Run No. = 6, Point No. = 109
 $C_N = 0.126$, $C_m = -0.0281$
 $\alpha = 3.1^\circ$, $M_\infty = 0.828$
 $R_{mac} = 6.0 \times 10^6$

Leading Edge Pressures

● starboard
 ○ port

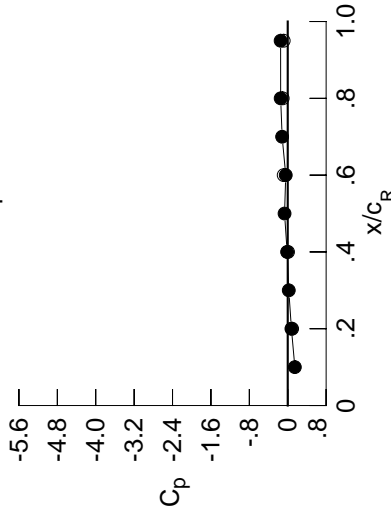

x/c_R	starb'd C_p	port C_p
0.10	0.1484	*****
0.20	0.0768	0.0909
0.30	0.0219	*****
0.40	-0.0126	0.0067
0.50	-0.0661	*****
0.60	-0.0416	-0.0842
0.70	-0.1164	*****
0.80	-0.1474	-0.1051
0.90	*****	*****
0.95	-0.1484	-0.0838

Surface Pressures

● upper, starboard
 ○ lower, port

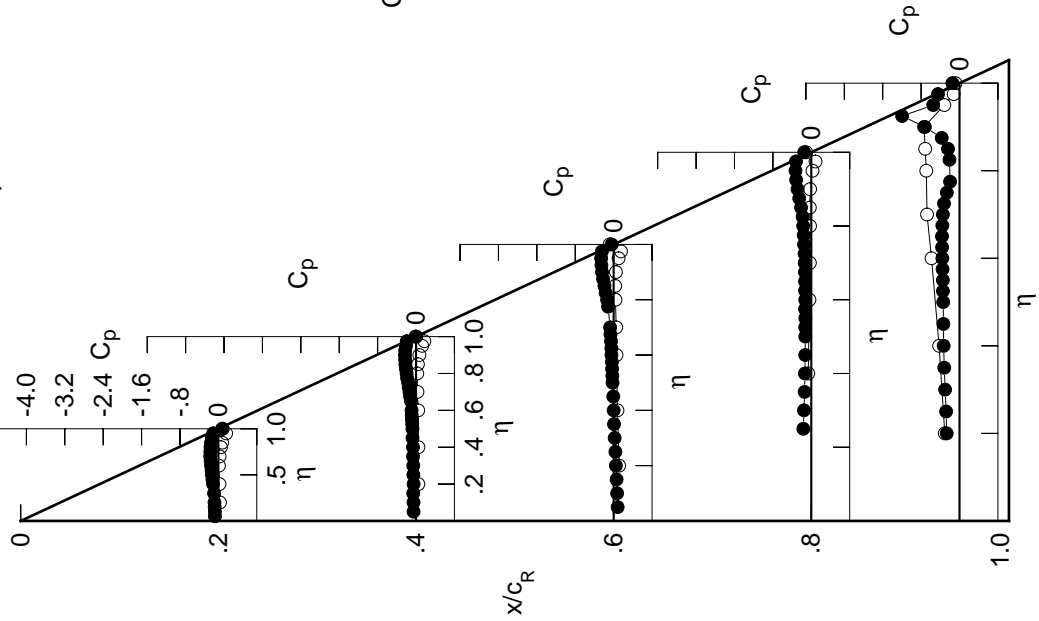

Table F2. Continued.

η	$x/c_R = .2$		$x/c_R = .4$		$x/c_R = .6$		$x/c_R = .8$		$x/c_R = .95$	
	$C_{p,u}$	$C_{p,l}$	$C_{p,u}$	$C_{p,l}$	$C_{p,u}$	$C_{p,l}$	$C_{p,u}$	$C_{p,l}$	$C_{p,u}$	$C_{p,l}$
0.050	-0.0923	-0.0711	0.0718	*****	*****	*****	*****	*****	*****	*****
0.100	-0.0924	-0.0712	0.0610	*****	*****	*****	*****	*****	*****	*****
0.150	-0.0957	-0.0729	0.0493	*****	*****	*****	*****	*****	*****	*****
0.200	-0.1022	-0.0671	0.0349	*****	*****	*****	*****	*****	*****	-0.2791
0.250	*****	-0.0742	0.0199	-0.1752	-0.2762	*****	*****	*****	*****	-0.2762
0.300	-0.1124	-0.0774	0.0071	-0.1639	-0.2805	*****	*****	*****	*****	-0.2805
0.350	*****	-0.0817	-0.0046	-0.1492	-0.3040	*****	*****	*****	*****	-0.3040
0.400	-0.1339	-0.0840	-0.0159	-0.1449	-0.3186	*****	*****	*****	*****	-0.3186
0.450	-0.1482	-0.0930	-0.0245	-0.1390	-0.3280	*****	*****	*****	*****	-0.3280
0.500	-0.1594	-0.0969	-0.0386	-0.1402	-0.3307	*****	*****	*****	*****	-0.3307
0.525	*****	-0.1009	-0.0442	-0.1409	-0.3361	*****	*****	*****	*****	-0.3361
0.550	-0.1713	-0.1089	-0.0504	-0.1398	-0.3356	*****	*****	*****	*****	-0.3356
0.575	*****	-0.1134	-0.0538	-0.1420	-0.3417	*****	*****	*****	*****	-0.3417
0.600	-0.1830	-0.1196	-0.0663	-0.1437	-0.3485	*****	*****	*****	*****	-0.3485
0.625	*****	*****	-0.0683	-0.1458	-0.3503	*****	*****	*****	*****	-0.3503
0.650	-0.1965	-0.1368	-0.0775	-0.1493	-0.3549	*****	*****	*****	*****	-0.3549
0.675	*****	-0.1542	-0.0886	-0.1506	-0.3449	*****	*****	*****	*****	-0.3449
0.700	-0.2080	-0.1691	-0.0992	-0.1575	-0.3375	*****	*****	*****	*****	-0.3375
0.725	*****	-0.1887	*****	-0.1628	-0.3060	*****	*****	*****	*****	-0.3060
0.750	-0.2117	-0.2033	*****	-0.1740	-0.2498	*****	*****	*****	*****	-0.2498
0.775	*****	-0.2265	-0.1481	-0.1845	-0.1832	*****	*****	*****	*****	-0.1832
0.800	-0.2115	-0.2435	-0.1742	-0.1978	*****	*****	*****	*****	*****	-0.1978
0.825	*****	-0.2615	-0.2081	-0.2144	-0.2001	*****	*****	*****	*****	-0.2001
0.850	-0.2069	-0.2746	-0.2410	-0.2513	-0.2212	*****	*****	*****	*****	-0.2212
0.875	*****	-0.2885	-0.2757	-0.2957	-0.3306	*****	*****	*****	*****	-0.3306
0.900	-0.1957	-0.2999	-0.3097	-0.3429	-0.6404	*****	*****	*****	*****	-0.6404
0.925	*****	-0.3054	-0.3323	-0.3851	-1.0665	*****	*****	*****	*****	-1.0665
0.950	-0.1842	-0.3036	-0.3561	-0.4180	-0.6004	*****	*****	*****	*****	-0.6004
0.975	*****	-0.3101	-0.3705	-0.4431	-0.5372	*****	*****	*****	*****	-0.5372
1.000	-0.0211	-0.1799	-0.2125	-0.3860	-0.3283	*****	*****	*****	*****	-0.3283
-0.200	$C_{p,l}$	$C_{p,l}$	$C_{p,l}$	$C_{p,l}$	$C_{p,l}$	$C_{p,l}$	$C_{p,l}$	$C_{p,l}$	$C_{p,l}$	$C_{p,l}$
-0.400	0.0561	0.0672	0.1299	*****	*****	*****	*****	*****	*****	-0.3371
-0.600	0.0451	0.0704	0.0955	-0.0495	-0.4573	*****	*****	*****	*****	-0.4573
-0.700	0.0421	0.0659	0.0772	-0.0258	-0.6360	*****	*****	*****	*****	-0.6360
-0.800	0.0557	0.0567	0.0732	-0.0130	-0.7199	*****	*****	*****	*****	-0.7199
-0.850	0.0870	0.0602	0.0650	-0.0032	-0.6801	*****	*****	*****	*****	-0.6801
-0.900	0.1133	0.0757	0.0673	-0.0046	-0.6960	*****	*****	*****	*****	-0.6960
-0.950	0.1876	0.1075	0.0846	0.0085	-0.7155	*****	*****	*****	*****	-0.7155
-0.975	0.1876	0.1607	0.1395	0.0667	-0.2966	*****	*****	*****	*****	-0.2966
-1.000	0.1937	0.1937	0.1777	0.1205	-0.1003	*****	*****	*****	*****	-0.1003
-1.000	-0.0025	-0.1551	-0.3092	-0.3296	-0.2564	*****	*****	*****	*****	-0.2564

Medium Radius L.E.
 Run No. = 6, Point No. = 110
 $C_N = 0.165$, $C_m = -0.0325$
 $\alpha = 4.2^\circ$, $M_\infty = 0.830$
 $R_{mac} = 6.0 \times 10^6$

Leading Edge Pressures

● starboard
 ○ port

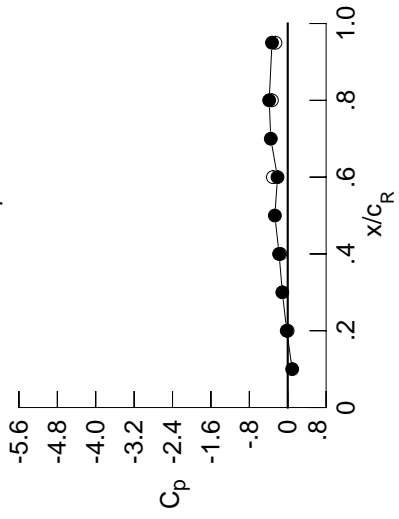

x/c_R	starb'd C_p	port C_p
0.10	0.0930	*****
0.20	-0.0211	-0.0025
0.30	-0.1126	*****
0.40	-0.1799	-0.1551
0.50	-0.2682	*****
0.60	-0.2125	-0.3092
0.70	-0.3531	*****
0.80	-0.3860	-0.3296
0.90	*****	*****
0.95	-0.3283	-0.2564

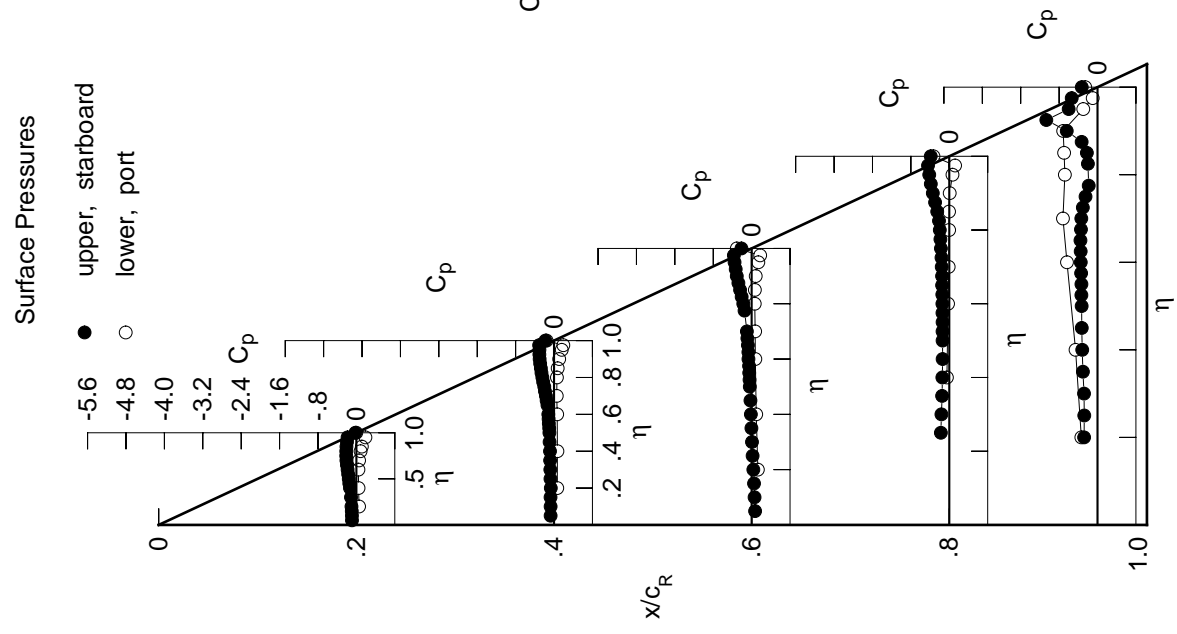

Table F2. Continued.

η	x/c_R .2	x/c_R .4	x/c_R .6	x/c_R .8	x/c_R .95
	$C_{p,u}$	$C_{p,u}$	$C_{p,u}$	$C_{p,u}$	$C_{p,u}$
0.050	-0.1134	-0.0849	0.0604	*****	*****
0.100	-0.1069	-0.0854	0.0499	*****	*****
0.150	-0.1154	-0.0887	0.0390	*****	*****
0.200	-0.1200	-0.0852	0.0218	*****	-0.2821
0.250	*****	-0.0909	0.0103	-0.1862	-0.2724
0.300	-0.1319	-0.0931	-0.0070	-0.1732	-0.2742
0.350	*****	-0.0972	-0.0174	-0.1628	-0.2897
0.400	-0.1539	-0.1023	-0.0283	-0.1560	-0.3087
0.450	-0.1701	-0.1130	-0.0384	-0.1507	-0.3247
0.500	-0.1835	-0.1147	-0.0528	-0.1517	-0.3340
0.525	*****	-0.1232	-0.0614	-0.1532	-0.3429
0.550	-0.1976	-0.1299	-0.0668	-0.1536	-0.3432
0.575	*****	-0.1386	-0.0734	-0.1591	-0.3507
0.600	-0.2141	-0.1432	-0.0822	-0.1579	-0.3513
0.625	*****	*****	-0.0902	-0.1602	-0.3559
0.650	-0.2287	-0.1605	-0.0982	-0.1665	-0.3567
0.675	*****	-0.1807	-0.1112	-0.1691	-0.3473
0.700	-0.2446	-0.1974	-0.1231	-0.1770	-0.3355
0.725	*****	-0.2180	*****	-0.1855	-0.3051
0.750	-0.2523	-0.2412	*****	-0.1993	-0.2522
0.775	*****	-0.2655	-0.1786	-0.2118	-0.1882
0.800	-0.2581	-0.2870	-0.2066	-0.2250	*****
0.825	*****	-0.3104	-0.2471	-0.2465	-0.2027
0.850	-0.2595	-0.3316	-0.2879	-0.2861	-0.2135
0.875	*****	-0.3539	-0.3297	-0.3380	-0.2852
0.900	-0.2588	-0.3702	-0.3756	-0.3983	-0.5194
0.925	*****	-0.3836	-0.4142	-0.4533	-0.7967
0.950	-0.2622	-0.3961	-0.4548	-0.5092	-0.6524
0.975	*****	-0.4370	-0.4951	-0.5592	-0.6293
1.000	-0.1329	-0.3814	-0.4111	-0.6716	-0.5461
	$C_{p,l}$	$C_{p,l}$	$C_{p,l}$	$C_{p,l}$	$C_{p,l}$
-0.200	0.0777	0.0836	0.1439	*****	-0.3533
-0.400	0.0675	0.0901	0.1097	-0.0377	-0.4687
-0.600	0.0729	0.0862	0.0957	-0.0104	-0.6629
-0.700	0.0899	0.0814	0.0921	0.0005	-0.7175
-0.800	0.1214	0.0899	0.0885	0.0160	-0.6658
-0.850	0.1473	0.1102	0.0937	0.0192	-0.6789
-0.900	*****	0.1431	0.1183	0.0375	-0.6871
-0.950	0.2103	0.1882	0.1683	0.0961	-0.2764
-0.975	*****	0.2060	0.1932	0.1393	-0.0813
-1.000	-0.1157	-0.3476	-0.5771	-0.6004	-0.4455

Medium Radius L.E.
 Run No. = 6, Point No. = 111
 $C_N = 0.203$, $C_m = -0.0378$
 $\alpha = 5.2^\circ$, $M_\infty = 0.829$
 $R_{mac} = 6.0 \times 10^6$

Leading Edge Pressures

● starboard
 ○ port

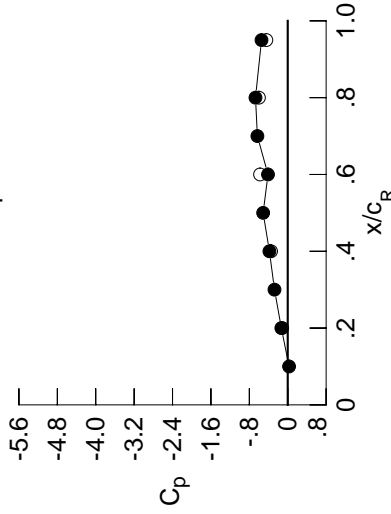

x/c_R	starb'd C_p	port C_p
0.10	0.0281	*****
0.20	-0.1329	-0.1157
0.30	-0.2756	*****
0.40	-0.3814	-0.3476
0.50	-0.5124	*****
0.60	-0.4111	-0.5771
0.70	-0.6321	*****
0.80	-0.6716	-0.6004
0.90	*****	*****
0.95	-0.5461	-0.4455

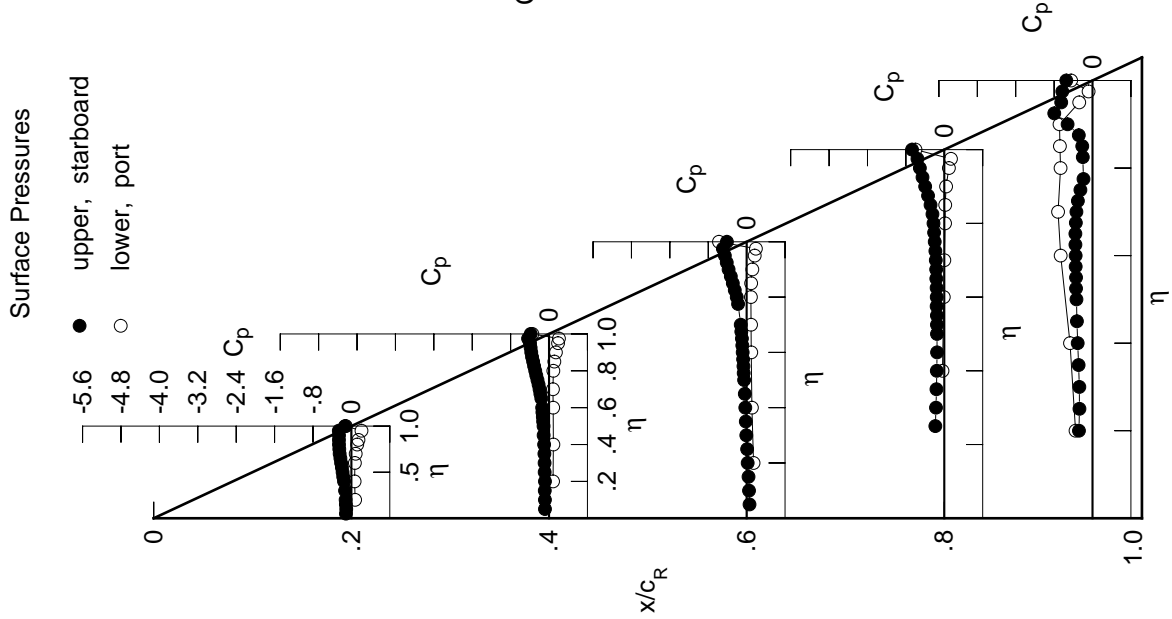
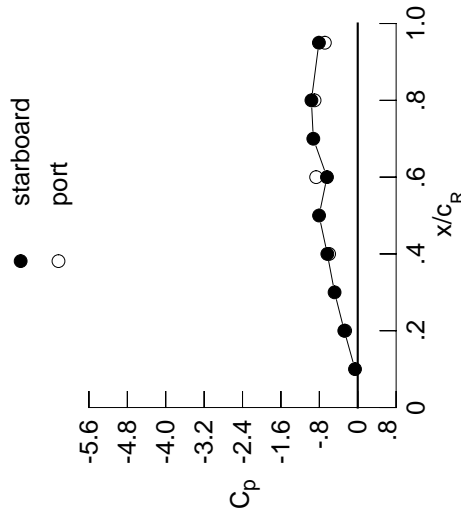

Table F2. Continued.

η	$x/c_R = 0.2$		$x/c_R = 0.4$		$x/c_R = 0.6$		$x/c_R = 0.8$		$x/c_R = 0.95$	
	$C_{p,u}$	$C_{p,u}$	$C_{p,u}$	$C_{p,u}$	$C_{p,u}$	$C_{p,u}$	$C_{p,u}$	$C_{p,u}$	$C_{p,u}$	$C_{p,u}$
0.050	-0.1260	-0.0972	0.0492	*****	*****	*****	*****	*****	*****	*****
0.100	-0.1269	-0.0991	0.0413	*****	*****	*****	*****	*****	*****	*****
0.150	-0.1305	-0.1054	0.0264	*****	*****	*****	*****	*****	*****	*****
0.200	-0.1378	-0.1000	0.0122	*****	*****	*****	*****	*****	*****	-0.2868
0.250	*****	-0.1058	-0.0027	-0.1939	-0.1939	-0.1939	-0.2653	-0.2653	-0.2653	-0.2653
0.300	-0.1499	-0.1089	-0.0162	-0.1826	-0.1826	-0.1826	-0.2618	-0.2618	-0.2618	-0.2618
0.350	*****	-0.1143	-0.0287	-0.1695	-0.1695	-0.1695	-0.2751	-0.2751	-0.2751	-0.2751
0.400	-0.1761	-0.1203	-0.0409	-0.1643	-0.1643	-0.1643	-0.3040	-0.3040	-0.3040	-0.3040
0.450	-0.1922	-0.1304	-0.0538	-0.1604	-0.1604	-0.1604	-0.3225	-0.3225	-0.3225	-0.3225
0.500	-0.2075	-0.1390	-0.0688	-0.1623	-0.1623	-0.1623	-0.3414	-0.3414	-0.3414	-0.3414
0.525	*****	-0.1453	-0.0778	-0.1634	-0.1634	-0.1634	-0.3537	-0.3537	-0.3537	-0.3537
0.550	-0.2242	-0.1527	-0.0833	-0.1669	-0.1669	-0.1669	-0.3607	-0.3607	-0.3607	-0.3607
0.575	*****	-0.1613	-0.0910	-0.1700	-0.1700	-0.1700	-0.3696	-0.3696	-0.3696	-0.3696
0.600	-0.2437	-0.1672	-0.1048	-0.1718	-0.1718	-0.1718	-0.3757	-0.3757	-0.3757	-0.3757
0.625	*****	*****	-0.1131	-0.1735	-0.1735	-0.1735	-0.3830	-0.3830	-0.3830	-0.3830
0.650	-0.2627	-0.1905	-0.1220	-0.1820	-0.1820	-0.1820	-0.3903	-0.3903	-0.3903	-0.3903
0.675	*****	-0.2089	-0.1369	-0.1906	-0.1906	-0.1906	-0.3864	-0.3864	-0.3864	-0.3864
0.700	-0.2814	-0.2287	-0.1537	-0.2024	-0.2024	-0.2024	-0.3814	-0.3814	-0.3814	-0.3814
0.725	*****	-0.2538	*****	-0.2138	-0.2138	-0.2138	-0.3592	-0.3592	-0.3592	-0.3592
0.750	-0.2947	-0.2780	*****	-0.2326	-0.2326	-0.2326	-0.3150	-0.3150	-0.3150	-0.3150
0.775	*****	-0.3063	-0.2134	-0.2491	-0.2491	-0.2491	-0.2546	-0.2546	-0.2546	-0.2546
0.800	-0.3067	-0.3345	-0.2432	-0.2664	-0.2664	-0.2664	*****	*****	*****	*****
0.825	*****	-0.3629	-0.2850	-0.2862	-0.2862	-0.2862	-0.2421	-0.2421	-0.2421	-0.2421
0.850	-0.3159	-0.3915	-0.3326	-0.3219	-0.3219	-0.3219	-0.2412	-0.2412	-0.2412	-0.2412
0.875	*****	-0.4215	-0.3812	-0.3751	-0.3751	-0.3751	-0.2680	-0.2680	-0.2680	-0.2680
0.900	-0.3269	-0.4457	-0.4409	-0.4420	-0.4420	-0.4420	-0.3127	-0.3127	-0.3127	-0.3127
0.925	*****	-0.4761	-0.4973	-0.5196	-0.5196	-0.5196	-0.3621	-0.3621	-0.3621	-0.3621
0.950	-0.3500	-0.4923	-0.5660	-0.5983	-0.5983	-0.5983	-0.6348	-0.6348	-0.6348	-0.6348
0.975	*****	-0.5771	-0.6414	-0.6910	-0.6910	-0.6910	-0.7192	-0.7192	-0.7192	-0.7192
1.000	-0.2803	-0.6338	-0.6409	-0.9651	-0.9651	-0.9651	-0.8084	-0.8084	-0.8084	-0.8084
-0.200	$C_{p,l}$	$C_{p,l}$	$C_{p,l}$	$C_{p,l}$	$C_{p,l}$	$C_{p,l}$	$C_{p,l}$	$C_{p,l}$	$C_{p,l}$	$C_{p,l}$
-0.400	0.0994	0.1076	0.1596	*****	*****	*****	-0.3746	-0.3746	-0.3746	-0.3746
-0.600	0.0933	0.1097	0.1272	-0.0212	-0.0212	-0.0212	-0.4865	-0.4865	-0.4865	-0.4865
-0.700	0.1023	0.1120	0.1152	0.0061	0.0061	0.0061	-0.6728	-0.6728	-0.6728	-0.6728
-0.800	0.1211	0.1081	0.1141	0.0193	0.0193	0.0193	-0.7088	-0.7088	-0.7088	-0.7088
-0.850	0.1520	0.1209	0.1151	0.0369	0.0369	0.0369	-0.6496	-0.6496	-0.6496	-0.6496
-0.900	0.1765	0.1430	0.1223	0.0431	0.0431	0.0431	-0.6607	-0.6607	-0.6607	-0.6607
-0.950	*****	0.1730	0.1477	0.0655	0.0655	0.0655	-0.6568	-0.6568	-0.6568	-0.6568
-0.975	0.2246	0.2075	0.1896	0.1207	0.1207	0.1207	-0.2583	-0.2583	-0.2583	-0.2583
-1.000	0.2070	0.1974	0.1497	-0.0683	-0.0683	-0.0683	-0.6845	-0.6845	-0.6845	-0.6845

Medium Radius L.E.
 Run No. = 6, Point No. = 112
 $C_N = 0.245$, $C_m = -0.0442$
 $\alpha = 6.3^\circ$, $M_\infty = 0.829$
 $R_{mac} = 6.0 \times 10^6$

Leading Edge Pressures



x/c_R	starb'd C_p	port C_p
0.10	-0.0566	*****
0.20	-0.2803	-0.2622
0.30	-0.4824	*****
0.40	-0.6338	-0.5960
0.50	-0.8056	*****
0.60	-0.6409	-0.8665
0.70	-0.9254	*****
0.80	-0.9651	-0.8994
0.90	*****	*****
0.95	-0.8084	-0.6845

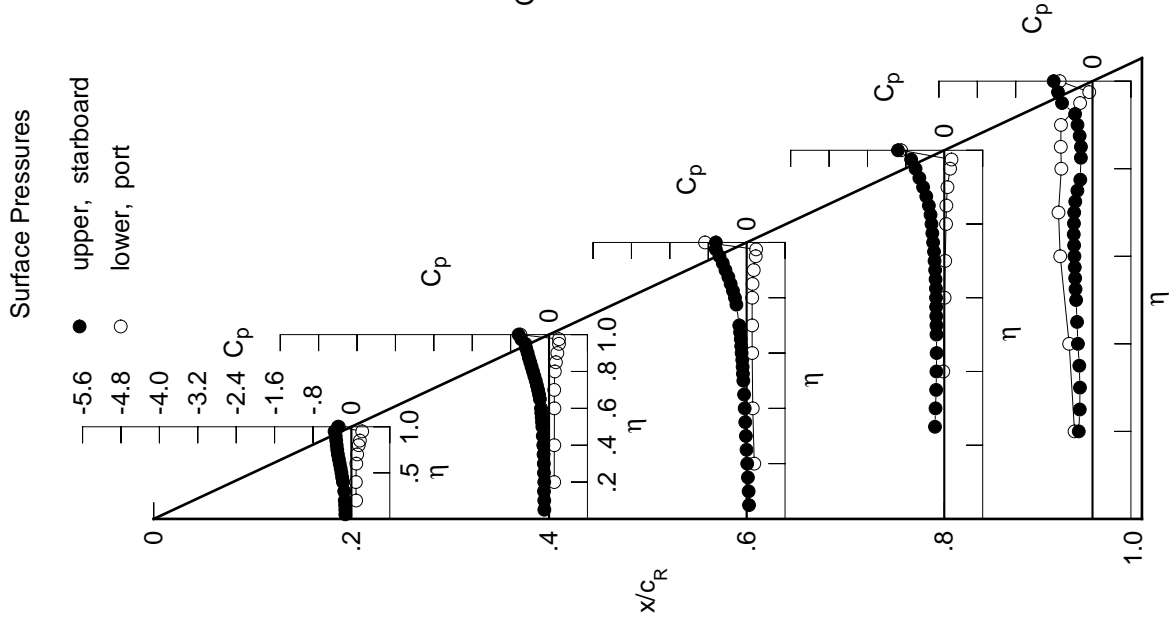
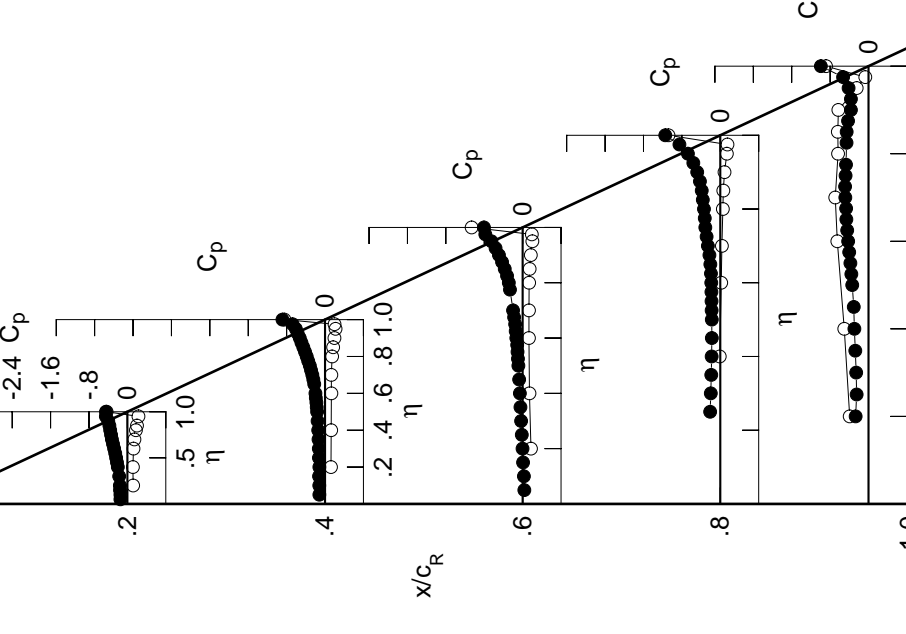
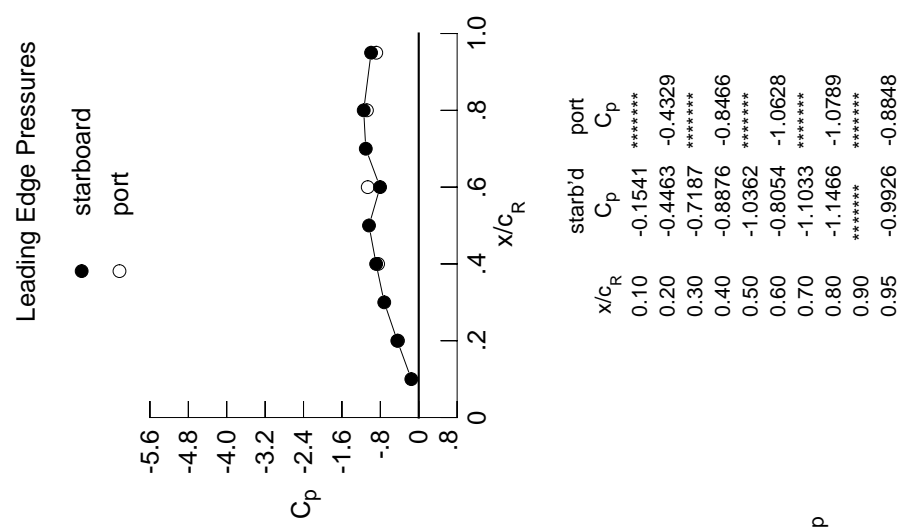

Table F2. Continued.

η	$x/c_R = .2$		$x/c_R = .4$		$x/c_R = .6$		$x/c_R = .8$		$x/c_R = .95$	
	$C_{p,u}$	$C_{p,l}$	$C_{p,u}$	$C_{p,l}$	$C_{p,u}$	$C_{p,l}$	$C_{p,u}$	$C_{p,l}$	$C_{p,u}$	$C_{p,l}$
0.050	-0.1453	-0.1186	0.0350	0.0350	0.0350	0.0350	0.0350	0.0350	0.0350	0.0350
0.100	-0.1459	-0.1199	0.0264	0.0264	0.0264	0.0264	0.0264	0.0264	0.0264	0.0264
0.150	-0.1536	-0.1252	0.0090	0.0090	0.0090	0.0090	0.0090	0.0090	0.0090	0.0090
0.200	-0.1568	-0.1185	-0.0021	-0.0021	-0.0021	-0.0021	-0.0021	-0.0021	-0.0021	-0.0021
0.250	0.0000	-0.1271	-0.0178	-0.0178	-0.0178	-0.0178	-0.0178	-0.0178	-0.0178	-0.0178
0.300	-0.1712	-0.1292	-0.0317	-0.0317	-0.0317	-0.0317	-0.0317	-0.0317	-0.0317	-0.0317
0.350	0.0000	-0.1357	-0.0455	-0.0455	-0.0455	-0.0455	-0.0455	-0.0455	-0.0455	-0.0455
0.400	-0.1990	-0.1421	-0.0576	-0.0576	-0.0576	-0.0576	-0.0576	-0.0576	-0.0576	-0.0576
0.450	-0.2169	-0.1550	-0.0725	-0.0725	-0.0725	-0.0725	-0.0725	-0.0725	-0.0725	-0.0725
0.500	-0.2347	-0.1652	-0.0891	-0.0891	-0.0891	-0.0891	-0.0891	-0.0891	-0.0891	-0.0891
0.525	0.0000	-0.1730	-0.0975	-0.0975	-0.0975	-0.0975	-0.0975	-0.0975	-0.0975	-0.0975
0.550	-0.2534	-0.1799	-0.1061	-0.1061	-0.1061	-0.1061	-0.1061	-0.1061	-0.1061	-0.1061
0.575	0.0000	-0.1916	-0.1133	-0.1133	-0.1133	-0.1133	-0.1133	-0.1133	-0.1133	-0.1133
0.600	-0.2757	-0.2002	-0.1316	-0.1316	-0.1316	-0.1316	-0.1316	-0.1316	-0.1316	-0.1316
0.625	0.0000	0.0000	-0.1452	-0.1452	-0.1452	-0.1452	-0.1452	-0.1452	-0.1452	-0.1452
0.650	-0.2993	-0.2245	-0.1562	-0.1562	-0.1562	-0.1562	-0.1562	-0.1562	-0.1562	-0.1562
0.675	0.0000	-0.2439	-0.1780	-0.1780	-0.1780	-0.1780	-0.1780	-0.1780	-0.1780	-0.1780
0.700	-0.3220	-0.2651	-0.1997	-0.1997	-0.1997	-0.1997	-0.1997	-0.1997	-0.1997	-0.1997
0.725	0.0000	-0.2912	0.0000	0.0000	0.0000	0.0000	0.0000	0.0000	0.0000	0.0000
0.750	-0.3403	-0.3164	0.0000	0.0000	0.0000	0.0000	0.0000	0.0000	0.0000	0.0000
0.775	0.0000	-0.3502	-0.2641	-0.2641	-0.2641	-0.2641	-0.2641	-0.2641	-0.2641	-0.2641
0.800	-0.3584	-0.3813	-0.2879	-0.2879	-0.2879	-0.2879	-0.2879	-0.2879	-0.2879	-0.2879
0.825	0.0000	-0.4165	-0.3251	-0.3251	-0.3251	-0.3251	-0.3251	-0.3251	-0.3251	-0.3251
0.850	-0.3751	-0.4527	-0.3731	-0.3731	-0.3731	-0.3731	-0.3731	-0.3731	-0.3731	-0.3731
0.875	0.0000	-0.4913	-0.4286	-0.4286	-0.4286	-0.4286	-0.4286	-0.4286	-0.4286	-0.4286
0.900	-0.3987	-0.5264	-0.4939	-0.4939	-0.4939	-0.4939	-0.4939	-0.4939	-0.4939	-0.4939
0.925	0.0000	-0.5693	-0.5639	-0.5639	-0.5639	-0.5639	-0.5639	-0.5639	-0.5639	-0.5639
0.950	-0.4485	-0.6087	-0.6494	-0.6494	-0.6494	-0.6494	-0.6494	-0.6494	-0.6494	-0.6494
0.975	0.0000	-0.6770	-0.7773	-0.7773	-0.7773	-0.7773	-0.7773	-0.7773	-0.7773	-0.7773
1.000	-0.4463	-0.8876	-0.8054	-0.8054	-0.8054	-0.8054	-0.8054	-0.8054	-0.8054	-0.8054
-0.200	0.1202	0.1240	0.1737	0.1737	0.1737	0.1737	0.1737	0.1737	0.1737	0.1737
-0.400	0.1150	0.1281	0.1421	0.1421	0.1421	0.1421	0.1421	0.1421	0.1421	0.1421
-0.600	0.1274	0.1321	0.1314	0.1314	0.1314	0.1314	0.1314	0.1314	0.1314	0.1314
-0.700	0.1466	0.1316	0.1317	0.1317	0.1317	0.1317	0.1317	0.1317	0.1317	0.1317
-0.800	0.1777	0.1474	0.1354	0.1354	0.1354	0.1354	0.1354	0.1354	0.1354	0.1354
-0.850	0.1997	0.1686	0.1454	0.1454	0.1454	0.1454	0.1454	0.1454	0.1454	0.1454
-0.900	0.0000	0.1957	0.1701	0.1701	0.1701	0.1701	0.1701	0.1701	0.1701	0.1701
-0.950	0.2303	0.2190	0.2028	0.2028	0.2028	0.2028	0.2028	0.2028	0.2028	0.2028
-0.975	0.0000	0.1980	0.1914	0.1914	0.1914	0.1914	0.1914	0.1914	0.1914	0.1914
-1.000	-0.4329	-0.8466	-1.0628	-1.0628	-1.0628	-1.0628	-1.0628	-1.0628	-1.0628	-1.0628

Medium Radius L.E.
 Run No. = 6, Point No. = 113
 $C_N = 0.293$, $C_m = -0.0537$
 $\alpha = 7.3^\circ$, $M_\infty = 0.830$
 $R_{mac} = 6.0 \times 10^6$



x/c_R	starb'd C_p	port C_p
0.10	-0.1541	0.0000
0.20	-0.4463	-0.4329
0.30	-0.7187	0.0000
0.40	-0.8876	-0.8466
0.50	-1.0362	0.0000
0.60	-0.8054	-1.0628
0.70	-1.1033	0.0000
0.80	-1.1466	-1.0789
0.90	0.0000	0.0000
0.95	-0.9926	-0.8848

Table F2. Continued.

η	$x/c_R = .2$		$x/c_R = .4$		$x/c_R = .6$		$x/c_R = .8$		$x/c_R = .95$	
	$C_{p,u}$	$C_{p,u}$	$C_{p,u}$	$C_{p,u}$	$C_{p,u}$	$C_{p,u}$	$C_{p,u}$	$C_{p,u}$	$C_{p,u}$	$C_{p,u}$
0.050	-0.1623	-0.1340	0.0221	*****	*****	*****	*****	*****	*****	
0.100	-0.1618	-0.1323	0.0108	*****	*****	*****	*****	*****	*****	
0.150	-0.1673	-0.1409	-0.0007	*****	*****	*****	*****	*****	*****	
0.200	-0.1754	-0.1356	-0.0168	*****	*****	*****	*****	*****	-0.2608	
0.250	*****	-0.1426	-0.0315	-0.2275	-0.2442	*****	*****	*****	*****	
0.300	-0.1901	-0.1465	-0.0483	-0.2164	-0.2527	*****	*****	*****	*****	
0.350	*****	-0.1534	-0.0607	-0.2046	-0.2687	*****	*****	*****	*****	
0.400	-0.2187	-0.1640	-0.0757	-0.1953	-0.3004	*****	*****	*****	*****	
0.450	-0.2382	-0.1761	-0.0869	-0.1942	-0.3315	*****	*****	*****	*****	
0.500	-0.2587	-0.1915	-0.1066	-0.1915	-0.3359	*****	*****	*****	*****	
0.525	*****	-0.1999	-0.1182	-0.1954	-0.3075	*****	*****	*****	*****	
0.550	-0.2802	-0.2124	-0.1304	-0.2040	-0.2174	*****	*****	*****	*****	
0.575	*****	-0.2211	-0.1444	-0.2289	-0.1530	*****	*****	*****	*****	
0.600	-0.3055	-0.2321	-0.1688	-0.2548	-0.1730	*****	*****	*****	*****	
0.625	*****	*****	-0.1933	-0.2591	-0.2299	*****	*****	*****	*****	
0.650	-0.3338	-0.2599	-0.2150	-0.2350	-0.2930	*****	*****	*****	*****	
0.675	*****	-0.2820	-0.2425	-0.2255	-0.3458	*****	*****	*****	*****	
0.700	-0.3628	-0.3026	-0.2597	-0.2227	-0.3894	*****	*****	*****	*****	
0.725	*****	-0.3266	*****	-0.2190	-0.4136	*****	*****	*****	*****	
0.750	-0.3853	-0.3567	*****	-0.2138	-0.4298	*****	*****	*****	*****	
0.775	*****	-0.3876	-0.2993	-0.1983	-0.5097	*****	*****	*****	*****	
0.800	-0.4115	-0.4270	-0.3174	-0.2783	*****	*****	*****	*****	*****	
0.825	*****	-0.4642	-0.3447	-0.7035	-0.9734	*****	*****	*****	*****	
0.850	-0.4394	-0.5088	-0.3930	-0.8591	-0.8864	*****	*****	*****	*****	
0.875	*****	-0.5544	-0.5034	-0.8548	-0.7860	*****	*****	*****	*****	
0.900	-0.4648	-0.6013	-0.7214	-0.8272	-0.7059	*****	*****	*****	*****	
0.925	*****	-0.6558	-0.8977	-0.7847	-0.6825	*****	*****	*****	*****	
0.950	-0.5435	-0.7091	-0.9683	-0.7501	-0.5938	*****	*****	*****	*****	
0.975	*****	-0.9399	-0.9797	-0.7468	-0.5775	*****	*****	*****	*****	
1.000	-0.6395	-1.0909	-0.8385	-0.8836	-0.6017	*****	*****	*****	*****	
-0.200	$C_{p,l}$	$C_{p,l}$	$C_{p,l}$	$C_{p,l}$	$C_{p,l}$	$C_{p,l}$	$C_{p,l}$	$C_{p,l}$	$C_{p,l}$	
-0.400	0.1474	0.1491	0.1934	*****	-0.3991	*****	*****	*****	*****	
-0.600	0.1432	0.1531	0.1642	0.0111	-0.5282	*****	*****	*****	*****	
-0.700	0.1565	0.1580	0.1557	0.0389	-0.6853	*****	*****	*****	*****	
-0.800	0.1771	0.1595	0.1563	0.0570	-0.6754	*****	*****	*****	*****	
-0.850	0.2070	0.1781	0.1631	0.0792	-0.6083	*****	*****	*****	*****	
-0.900	0.2256	0.1982	0.1741	0.0869	-0.6126	*****	*****	*****	*****	
-0.950	*****	0.2226	0.1981	0.1123	-0.5961	*****	*****	*****	*****	
-0.975	0.2363	0.2319	0.2204	0.1567	-0.2277	*****	*****	*****	*****	
-1.000	0.2363	0.1877	0.1934	0.1592	-0.0535	*****	*****	*****	*****	
	-0.6317	-1.0487	-1.1536	-0.9043	-0.6234	*****	*****	*****	*****	

Medium Radius L.E.
 Run No. = 6, Point No. = 114
 $C_N = 0.354$, $C_m = -0.0680$
 $\alpha = 8.3^\circ$, $M_\infty = 0.828$
 $R_{mac} = 6.0 \times 10^6$

Leading Edge Pressures

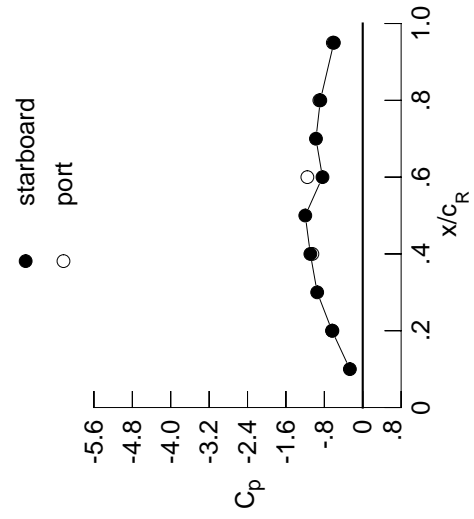

x/c_R	starb'd C_p	port C_p
0.10	-0.2677	*****
0.20	-0.6395	-0.6317
0.30	-0.9486	*****
0.40	-1.0909	-1.0487
0.50	-1.1971	*****
0.60	-0.8385	-1.1536
0.70	-0.9745	*****
0.80	-0.8836	-0.9043
0.90	*****	*****
0.95	-0.6017	-0.6234

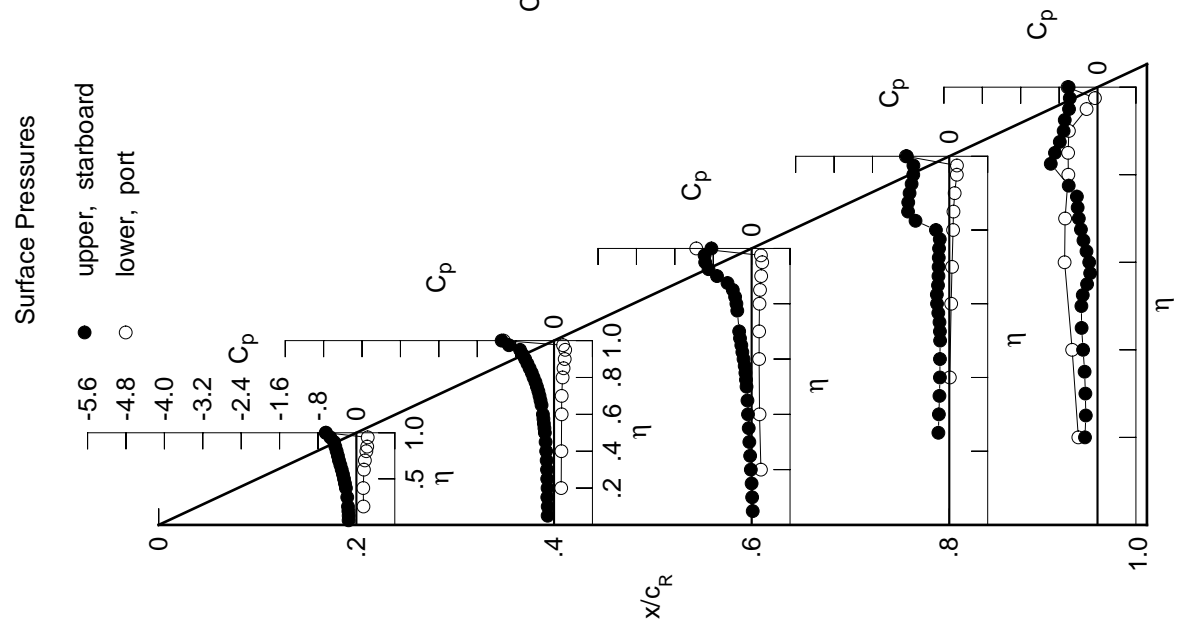
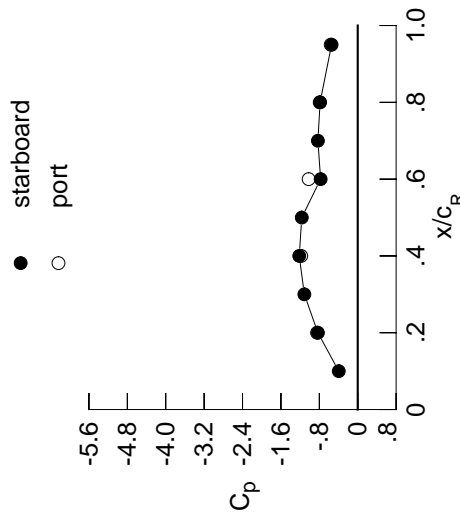

Table F2. Continued.

η	$x/c_R = .2$		$x/c_R = .4$		$x/c_R = .6$		$x/c_R = .8$		$x/c_R = .95$	
	$C_{p,u}$	$C_{p,u}$	$C_{p,u}$	$C_{p,u}$	$C_{p,u}$	$C_{p,u}$	$C_{p,u}$	$C_{p,u}$	$C_{p,u}$	$C_{p,u}$
0.050	-0.1792	-0.1562	0.0061	*****	*****	*****	*****	*****	*****	*****
0.100	-0.1801	-0.1542	-0.0054	*****	*****	*****	*****	*****	*****	*****
0.150	-0.1890	-0.1641	-0.0212	*****	*****	*****	*****	*****	*****	*****
0.200	-0.1926	-0.1571	-0.0355	*****	*****	*****	*****	*****	*****	-0.2973
0.250	*****	-0.1656	-0.0532	-0.2466	-0.2571	*****	*****	*****	*****	-0.2571
0.300	-0.2104	-0.1711	-0.0657	-0.2350	-0.2330	*****	*****	*****	*****	-0.2330
0.350	*****	-0.1801	-0.0821	-0.2191	-0.2637	*****	*****	*****	*****	-0.2637
0.400	-0.2430	-0.1912	-0.0934	-0.2125	-0.3011	*****	*****	*****	*****	-0.3011
0.450	-0.2637	-0.2057	-0.1067	-0.2190	-0.2011	*****	*****	*****	*****	-0.2011
0.500	-0.2859	-0.2267	-0.1392	-0.2503	-0.1894	*****	*****	*****	*****	-0.1894
0.525	*****	-0.2379	-0.1633	-0.2311	-0.2421	*****	*****	*****	*****	-0.2421
0.550	-0.3100	-0.2578	-0.1965	-0.2211	-0.2968	*****	*****	*****	*****	-0.2968
0.575	*****	-0.2696	-0.2141	-0.2176	-0.3587	*****	*****	*****	*****	-0.3587
0.600	-0.3374	-0.2841	-0.2201	-0.2115	-0.4066	*****	*****	*****	*****	-0.4066
0.625	*****	*****	-0.2068	-0.2079	-0.4397	*****	*****	*****	*****	-0.4397
0.650	-0.3708	-0.3129	-0.2016	-0.2071	-0.4531	*****	*****	*****	*****	-0.4531
0.675	*****	-0.3344	-0.2035	-0.1942	-0.4403	*****	*****	*****	*****	-0.4403
0.700	-0.4029	-0.3515	-0.2029	-0.1839	-0.4626	*****	*****	*****	*****	-0.4626
0.725	*****	-0.3758	*****	-0.1908	-0.5974	*****	*****	*****	*****	-0.5974
0.750	-0.4334	-0.4008	*****	-0.3570	-0.7861	*****	*****	*****	*****	-0.7861
0.775	*****	-0.4345	-0.1938	-0.7251	-0.8838	*****	*****	*****	*****	-0.8838
0.800	-0.4667	-0.4713	-0.4578	-0.9349	*****	*****	*****	*****	*****	-0.9349
0.825	*****	-0.5117	-0.8823	-0.9950	-0.6871	*****	*****	*****	*****	-0.6871
0.850	-0.5073	-0.5587	-0.9864	-0.9231	-0.6050	*****	*****	*****	*****	-0.6050
0.875	*****	-0.6216	-0.9895	-0.7990	-0.5969	*****	*****	*****	*****	-0.5969
0.900	-0.5489	-0.7091	-0.9590	-0.7364	-0.6082	*****	*****	*****	*****	-0.6082
0.925	*****	-0.8565	-0.9101	-0.7093	-0.6564	*****	*****	*****	*****	-0.6564
0.950	-0.6115	-1.0261	-0.8786	-0.7144	-0.5807	*****	*****	*****	*****	-0.5807
0.975	*****	-1.1879	-0.8606	-0.6922	-0.5337	*****	*****	*****	*****	-0.5337
1.000	-0.8300	-1.2186	-0.7732	-0.7843	-0.5451	*****	*****	*****	*****	-0.5451
-0.200	$C_{p,l}$	$C_{p,l}$	$C_{p,l}$	$C_{p,l}$	$C_{p,l}$	$C_{p,l}$	$C_{p,l}$	$C_{p,l}$	$C_{p,l}$	$C_{p,l}$
-0.400	0.1707	0.1736	0.2101	*****	-0.4202	*****	*****	*****	*****	-0.4202
-0.600	0.1700	0.1750	0.1801	0.0246	-0.6124	*****	*****	*****	*****	-0.6124
-0.700	0.1850	0.1828	0.1733	0.0542	-0.6747	*****	*****	*****	*****	-0.6747
-0.800	0.2051	0.1867	0.1738	0.0740	-0.6585	*****	*****	*****	*****	-0.6585
-0.850	0.2326	0.2055	0.1846	0.0945	-0.5948	*****	*****	*****	*****	-0.5948
-0.900	0.2485	0.2247	0.1980	0.1055	-0.5944	*****	*****	*****	*****	-0.5944
-0.950	*****	0.2433	0.2182	0.1298	-0.5715	*****	*****	*****	*****	-0.5715
-0.975	0.2368	0.2388	0.2317	0.1671	-0.2144	*****	*****	*****	*****	-0.2144
-1.000	*****	0.1753	0.1896	0.1577	-0.0467	*****	*****	*****	*****	-0.0467
	-0.8472	-1.1765	-1.0228	-0.7921	-0.5621	*****	*****	*****	*****	-0.5621

Medium Radius L.E.
 Run No. = 6, Point No. = 115
 $C_N = 0.410$, $C_m = -0.0786$
 $\alpha = 9.3^\circ$, $M_\infty = 0.829$
 $R_{mac} = 6.0 \times 10^6$

Leading Edge Pressures



x/c_R	starb'd C_p	port C_p
0.10	-0.3950	*****
0.20	-0.8300	-0.8472
0.30	-1.1123	*****
0.40	-1.2186	-1.1765
0.50	-1.1659	*****
0.60	-0.7732	-1.0228
0.70	-0.8297	*****
0.80	-0.7843	-0.7921
0.90	*****	*****
0.95	-0.5451	-0.5621

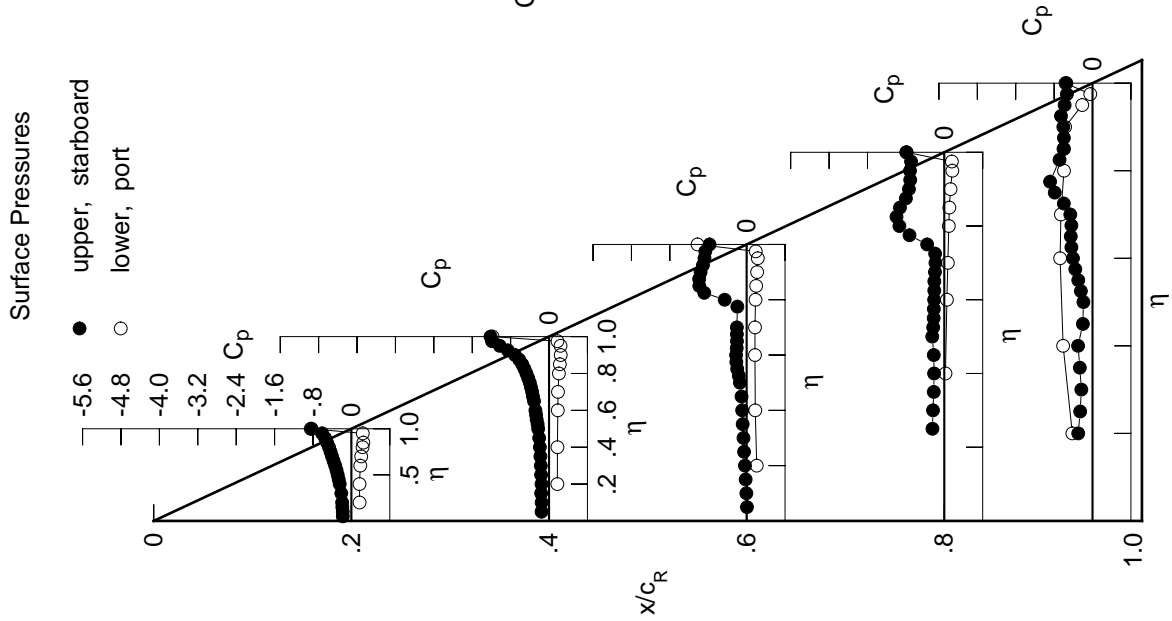
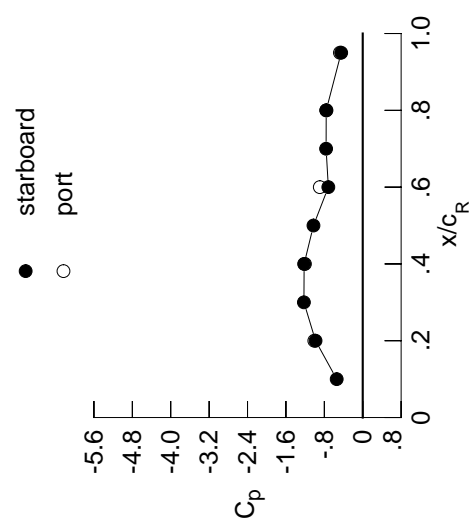

Table F2. Continued.

η	$x/c_R = .2$		$x/c_R = .4$		$x/c_R = .6$		$x/c_R = .8$		$x/c_R = .95$	
	$C_{p,u}$	$C_{p,u}$	$C_{p,u}$	$C_{p,u}$	$C_{p,u}$	$C_{p,u}$	$C_{p,u}$	$C_{p,u}$	$C_{p,u}$	$C_{p,u}$
0.050	-0.1958	-0.1797	-0.0175	*****	*****	*****	*****	*****	*****	*****
0.100	-0.1977	-0.1815	-0.0267	*****	*****	*****	*****	*****	*****	*****
0.150	-0.2096	-0.1877	-0.0431	*****	*****	*****	*****	*****	*****	*****
0.200	-0.2120	-0.1837	-0.0593	*****	*****	*****	*****	*****	*****	-0.2873
0.250	*****	-0.1930	-0.0751	*****	*****	*****	*****	*****	*****	-0.2422
0.300	-0.2352	-0.1967	-0.0899	-0.2472	-0.2652	*****	*****	*****	*****	-0.2652
0.350	*****	-0.2053	-0.1030	-0.2399	-0.2597	*****	*****	*****	*****	-0.2597
0.400	-0.2695	-0.2186	-0.1299	-0.2549	-0.1652	*****	*****	*****	*****	-0.1652
0.450	-0.2917	-0.2474	-0.1745	-0.2282	-0.2411	*****	*****	*****	*****	-0.2411
0.500	-0.3146	-0.2753	-0.1746	-0.2225	-0.3467	*****	*****	*****	*****	-0.3467
0.525	*****	-0.2947	-0.1688	-0.2195	-0.4060	*****	*****	*****	*****	-0.4060
0.550	-0.3427	-0.3084	-0.1710	-0.2163	-0.4433	*****	*****	*****	*****	-0.4433
0.575	*****	-0.3178	-0.1691	-0.2118	-0.4864	*****	*****	*****	*****	-0.4864
0.600	-0.3717	-0.3209	-0.1777	-0.2052	-0.4965	*****	*****	*****	*****	-0.4965
0.625	*****	*****	-0.1781	-0.1936	-0.5023	*****	*****	*****	*****	-0.5023
0.650	-0.4080	-0.3298	-0.1767	-0.1929	-0.5121	*****	*****	*****	*****	-0.5121
0.675	*****	-0.3426	-0.1758	-0.2221	-0.5588	*****	*****	*****	*****	-0.5588
0.700	-0.4463	-0.3568	-0.1686	-0.3512	-0.6901	*****	*****	*****	*****	-0.6901
0.725	*****	-0.3757	*****	-0.6252	-0.8404	*****	*****	*****	*****	-0.8404
0.750	-0.4831	-0.3964	*****	-0.8979	-0.8921	*****	*****	*****	*****	-0.8921
0.775	*****	-0.4250	-0.9560	-1.0381	-0.7556	*****	*****	*****	*****	-0.7556
0.800	-0.5250	-0.5159	-1.0921	-1.0365	*****	*****	*****	*****	*****	*****
0.825	*****	-0.7381	-1.0950	-0.9102	-0.5618	*****	*****	*****	*****	-0.5618
0.850	-0.5725	-0.9459	-1.0427	-0.7832	-0.5409	*****	*****	*****	*****	-0.5409
0.875	*****	-1.0599	-0.9791	-0.7522	-0.5442	*****	*****	*****	*****	-0.5442
0.900	-0.6289	-1.1034	-0.8953	-0.7243	-0.5472	*****	*****	*****	*****	-0.5472
0.925	*****	-1.1075	-0.8435	-0.6913	-0.5623	*****	*****	*****	*****	-0.5623
0.950	-0.7079	-1.0906	-0.8100	-0.7321	-0.4968	*****	*****	*****	*****	-0.4968
0.975	*****	-1.0873	-0.7921	-0.7041	-0.4329	*****	*****	*****	*****	-0.4329
1.000	-0.9830	-1.2209	-0.7166	-0.7611	-0.4486	*****	*****	*****	*****	-0.4486
-0.200	$C_{p,l}$	$C_{p,l}$	$C_{p,l}$	$C_{p,l}$	$C_{p,l}$	$C_{p,l}$	$C_{p,l}$	$C_{p,l}$	$C_{p,l}$	$C_{p,l}$
-0.400	0.1996	0.1985	0.2289	*****	*****	*****	*****	*****	*****	-0.4490
-0.600	0.1977	0.2014	0.1986	0.0381	-0.6581	*****	*****	*****	*****	-0.6581
-0.700	0.2152	0.2071	0.1944	0.0683	-0.6651	*****	*****	*****	*****	-0.6651
-0.800	0.2346	0.2126	0.1981	0.0868	-0.6535	*****	*****	*****	*****	-0.6535
-0.850	0.2583	0.2328	0.2058	0.1100	-0.5850	*****	*****	*****	*****	-0.5850
-0.900	0.2699	0.2495	0.2187	0.1207	-0.5822	*****	*****	*****	*****	-0.5822
-0.950	*****	0.2640	0.2370	0.1455	-0.5541	*****	*****	*****	*****	-0.5541
-0.975	0.2335	0.2466	0.2386	0.1744	-0.2043	*****	*****	*****	*****	-0.2043
-1.000	*****	0.1673	0.1841	0.1535	-0.0419	*****	*****	*****	*****	-0.0419
-1.000	-1.0085	-1.2038	-0.8940	-0.7561	-0.4755	*****	*****	*****	*****	-0.4755

Medium Radius L.E.
 Run No. = 6, Point No. = 116
 $C_N = 0.464$, $C_m = -0.0860$
 $\alpha = 10.4^\circ$, $M_\infty = 0.829$
 $R_{mac} = 6.0 \times 10^6$

Leading Edge Pressures



x/c_R	starb'd C_p	port C_p
0.10	-0.5427	*****
0.20	-0.9830	-1.0085
0.30	-1.2252	*****
0.40	-1.2209	-1.2038
0.50	-1.0263	*****
0.60	-0.7166	-0.8940
0.70	-0.7630	*****
0.80	-0.7611	-0.7561
0.90	*****	*****
0.95	-0.4486	-0.4755

Surface Pressures

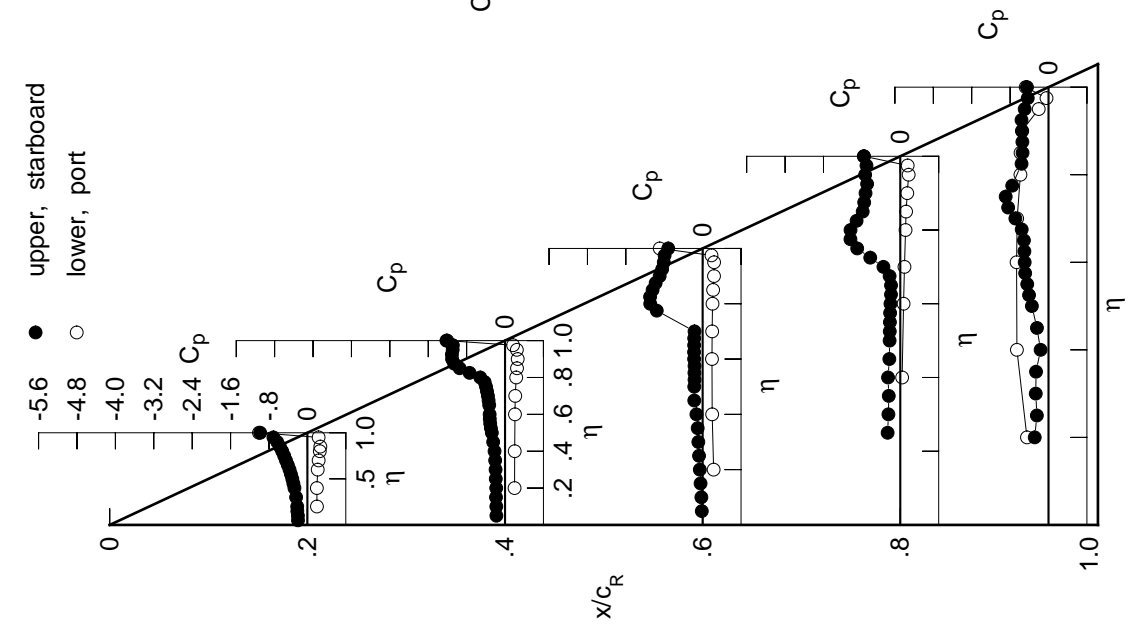
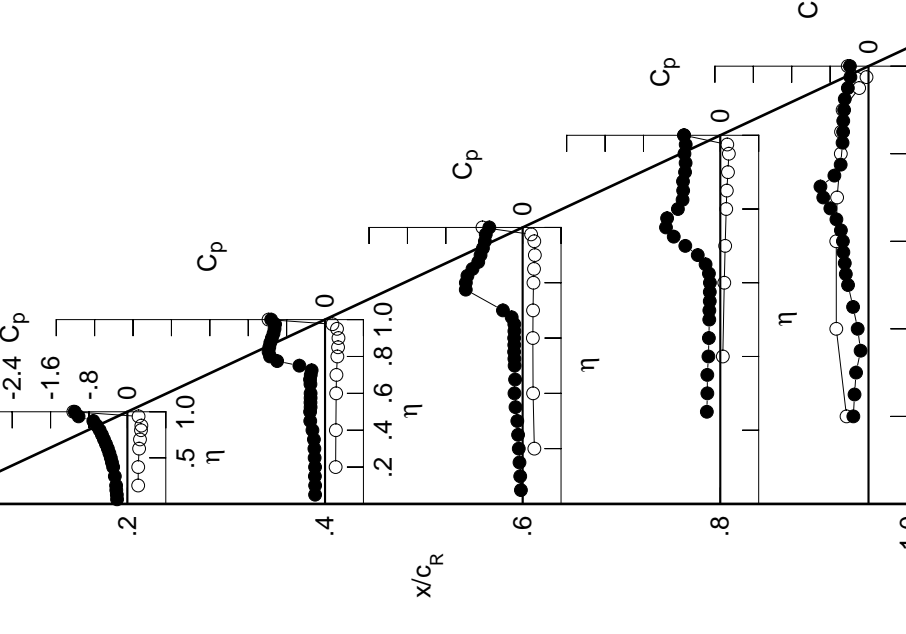
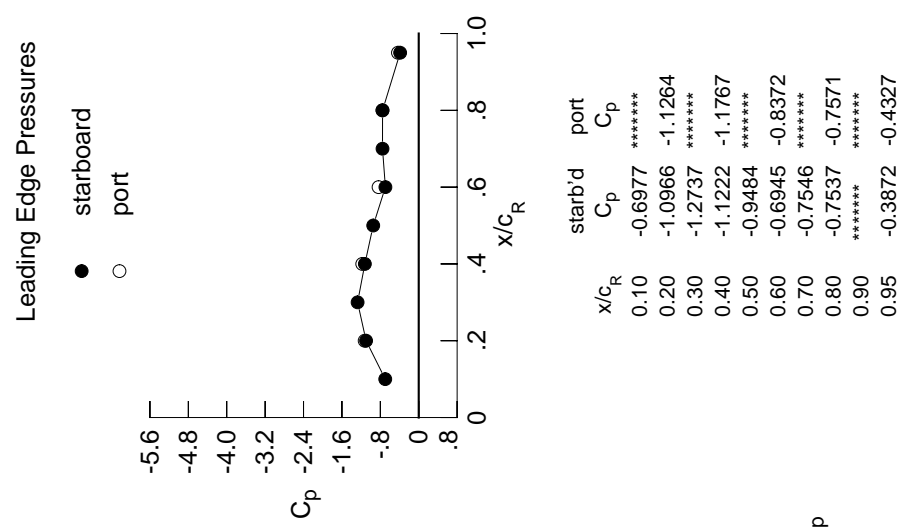

Table F2. Continued.

η	$x/c_R = .2$		$x/c_R = .4$		$x/c_R = .6$		$x/c_R = .8$		$x/c_R = .95$	
	$C_{p,u}$	$C_{p,u}$	$C_{p,u}$	$C_{p,u}$	$C_{p,u}$	$C_{p,u}$	$C_{p,u}$	$C_{p,u}$	$C_{p,u}$	$C_{p,u}$
0.050	-0.2149	-0.2069	-0.0359	*****	*****	*****	*****	*****	*****	*****
0.100	-0.2199	-0.2065	-0.0502	*****	*****	*****	*****	*****	*****	*****
0.150	-0.2311	-0.2110	-0.0654	*****	*****	*****	*****	*****	*****	*****
0.200	-0.2351	-0.2083	-0.0806	*****	*****	*****	*****	*****	*****	*****
0.250	*****	-0.2169	-0.0954	-0.2796	-0.2913	*****	*****	*****	*****	*****
0.300	-0.2616	-0.2216	-0.1114	-0.2698	-0.2594	*****	*****	*****	*****	*****
0.350	*****	-0.2324	-0.1491	-0.2703	-0.1645	*****	*****	*****	*****	*****
0.400	-0.2969	-0.2626	-0.1704	-0.2469	-0.2256	*****	*****	*****	*****	*****
0.450	-0.3213	-0.3077	-0.1579	-0.2373	-0.3219	*****	*****	*****	*****	*****
0.500	-0.3456	-0.3111	-0.1670	-0.2295	-0.4263	*****	*****	*****	*****	*****
0.525	*****	-0.3012	-0.1718	-0.2282	-0.4731	*****	*****	*****	*****	*****
0.550	-0.3754	-0.3033	-0.1777	-0.2195	-0.4942	*****	*****	*****	*****	*****
0.575	*****	-0.3005	-0.1742	-0.2187	-0.5240	*****	*****	*****	*****	*****
0.600	-0.4069	-0.3005	-0.1771	-0.2159	-0.5332	*****	*****	*****	*****	*****
0.625	*****	*****	-0.1719	-0.2370	-0.5752	*****	*****	*****	*****	*****
0.650	-0.4463	-0.3040	-0.1734	-0.3068	-0.6688	*****	*****	*****	*****	*****
0.675	*****	-0.3129	-0.2282	-0.4698	-0.7954	*****	*****	*****	*****	*****
0.700	-0.4883	-0.2976	-0.4105	-0.7285	-0.9426	*****	*****	*****	*****	*****
0.725	*****	-0.2793	*****	-0.9693	-1.0013	*****	*****	*****	*****	*****
0.750	-0.5304	-0.5347	*****	-1.1313	-0.7113	*****	*****	*****	*****	*****
0.775	*****	-0.9978	-1.1850	-1.1082	-0.5803	*****	*****	*****	*****	*****
0.800	-0.5778	-1.1456	-1.1834	-0.8828	*****	*****	*****	*****	*****	*****
0.825	*****	-1.1756	-1.1502	-0.7857	-0.5405	*****	*****	*****	*****	*****
0.850	-0.6390	-1.1618	-1.0447	-0.7737	-0.5293	*****	*****	*****	*****	*****
0.875	*****	-1.1397	-0.9251	-0.7770	-0.5261	*****	*****	*****	*****	*****
0.900	-0.7092	-1.1075	-0.8771	-0.7341	-0.5088	*****	*****	*****	*****	*****
0.925	*****	-1.0728	-0.8269	-0.7223	-0.4944	*****	*****	*****	*****	*****
0.950	-1.0177	-1.0517	-0.7867	-0.7466	-0.4306	*****	*****	*****	*****	*****
0.975	*****	-1.0410	-0.7676	-0.7206	-0.3767	*****	*****	*****	*****	*****
1.000	-1.0966	-1.1222	-0.6945	-0.7537	-0.3872	*****	*****	*****	*****	*****
-0.200	$C_{p,l}$	$C_{p,l}$	$C_{p,l}$	$C_{p,l}$	$C_{p,l}$	$C_{p,l}$	$C_{p,l}$	$C_{p,l}$	$C_{p,l}$	$C_{p,l}$
-0.400	0.2246	0.2205	0.2439	*****	-0.4575	*****	*****	*****	*****	*****
-0.600	0.2259	0.2256	0.2174	0.0525	-0.6712	*****	*****	*****	*****	*****
-0.700	0.2439	0.2322	0.2127	0.0829	-0.6718	*****	*****	*****	*****	*****
-0.800	0.2625	0.2377	0.2165	0.1014	-0.6540	*****	*****	*****	*****	*****
-0.850	0.2834	0.2569	0.2257	0.1237	-0.5770	*****	*****	*****	*****	*****
-0.900	0.2911	0.2711	0.2367	0.1361	-0.5720	*****	*****	*****	*****	*****
-0.950	*****	0.2804	0.2541	0.1596	-0.5391	*****	*****	*****	*****	*****
-0.975	0.2328	0.2494	0.2424	0.1782	-0.1956	*****	*****	*****	*****	*****
-1.000	0.2338	0.1544	0.1760	0.1458	-0.0414	*****	*****	*****	*****	*****
	-1.1264	-1.1767	-0.8372	-0.7571	-0.4327	*****	*****	*****	*****	*****

Medium Radius L.E.
 Run No. = 6, Point No. = 117
 $C_N = 0.521$, $C_m = -0.0962$
 $\alpha = 11.4^\circ$, $M_\infty = 0.829$
 $R_{mac} = 6.0 \times 10^6$



x/c_R	starb'd C_p	port C_p
0.10	-0.6977	*****
0.20	-1.0966	-1.1264
0.30	-1.2737	*****
0.40	-1.1222	-1.1767
0.50	-0.9484	*****
0.60	-0.6945	-0.8372
0.70	-0.7546	*****
0.80	-0.7537	-0.7571
0.90	*****	*****
0.95	-0.3872	-0.4327

Table F2. Continued.

η	$x/c_R = .2$		$x/c_R = .4$		$x/c_R = .6$		$x/c_R = .8$		$x/c_R = .95$	
	$C_{p,u}$	$C_{p,u}$	$C_{p,u}$	$C_{p,u}$	$C_{p,u}$	$C_{p,u}$	$C_{p,u}$	$C_{p,u}$	$C_{p,u}$	$C_{p,u}$
0.050	-0.2386	-0.2362	-0.0570	*****	*****	*****	*****	*****	*****	*****
0.100	-0.2434	-0.2377	-0.0720	*****	*****	*****	*****	*****	*****	*****
0.150	-0.2555	-0.2429	-0.0861	*****	*****	*****	*****	*****	*****	*****
0.200	-0.2617	-0.2415	-0.1021	*****	*****	*****	*****	*****	*****	*****
0.250	*****	-0.2463	-0.1172	-0.3001	-0.3004	*****	*****	*****	*****	-0.3416
0.300	-0.2929	-0.2514	-0.1573	-0.2979	-0.1664	*****	*****	*****	*****	*****
0.350	*****	-0.2905	-0.1619	-0.2719	-0.1916	*****	*****	*****	*****	*****
0.400	-0.3321	-0.3281	-0.1648	-0.2612	-0.2735	*****	*****	*****	*****	*****
0.450	-0.3568	-0.3047	-0.1683	-0.2499	-0.3838	*****	*****	*****	*****	*****
0.500	-0.3817	-0.2993	-0.1837	-0.2433	-0.4739	*****	*****	*****	*****	*****
0.525	*****	-0.3002	-0.1841	-0.2427	-0.5083	*****	*****	*****	*****	*****
0.550	-0.4122	-0.3040	-0.1840	-0.2430	-0.5266	*****	*****	*****	*****	*****
0.575	*****	-0.3066	-0.1805	-0.2570	-0.5690	*****	*****	*****	*****	*****
0.600	-0.4440	-0.3053	-0.1929	-0.2929	-0.6209	*****	*****	*****	*****	*****
0.625	*****	*****	-0.2198	-0.3753	-0.7247	*****	*****	*****	*****	*****
0.650	-0.4843	-0.2782	-0.3238	-0.5371	-0.8691	*****	*****	*****	*****	*****
0.675	*****	-0.2775	-0.5678	-0.7632	-1.0052	*****	*****	*****	*****	*****
0.700	-0.5288	-0.4036	-0.8874	-0.9919	-1.0899	*****	*****	*****	*****	*****
0.725	*****	-0.8934	*****	-1.1712	-0.6738	*****	*****	*****	*****	*****
0.750	-0.5725	-1.2066	*****	-1.1339	-0.5671	*****	*****	*****	*****	*****
0.775	*****	-1.2861	-1.2713	-0.8758	-0.5337	*****	*****	*****	*****	*****
0.800	-0.6283	-1.2874	-1.2073	-0.8027	*****	*****	*****	*****	*****	*****
0.825	*****	-1.2498	-1.0584	-0.8020	-0.5253	*****	*****	*****	*****	*****
0.850	-0.7637	-1.2032	-0.9433	-0.8132	-0.5077	*****	*****	*****	*****	*****
0.875	*****	-1.1455	-0.9167	-0.7897	-0.5005	*****	*****	*****	*****	*****
0.900	-0.9977	-1.0898	-0.8821	-0.7527	-0.4737	*****	*****	*****	*****	*****
0.925	*****	-1.0510	-0.8273	-0.7558	-0.4535	*****	*****	*****	*****	*****
0.950	-1.2240	-1.0287	-0.8002	-0.7668	-0.3928	*****	*****	*****	*****	*****
0.975	*****	-1.0165	-0.7849	-0.7449	-0.3497	*****	*****	*****	*****	*****
1.000	-1.1865	-1.0619	-0.7208	-0.7604	-0.3553	*****	*****	*****	*****	*****
-0.200	$C_{p,l}$	$C_{p,l}$	$C_{p,l}$	$C_{p,l}$	$C_{p,l}$	$C_{p,l}$	$C_{p,l}$	$C_{p,l}$	$C_{p,l}$	$C_{p,l}$
-0.400	0.2520	0.2380	0.2620	*****	*****	-0.4755	*****	*****	*****	*****
-0.600	0.2524	0.2461	0.2343	0.0655	-0.6774	*****	*****	*****	*****	*****
-0.700	0.2887	0.2598	0.2337	0.1129	-0.6454	*****	*****	*****	*****	*****
-0.800	0.3060	0.2773	0.2413	0.1374	-0.5707	*****	*****	*****	*****	*****
-0.850	0.3090	0.2889	0.2515	0.1486	-0.5623	*****	*****	*****	*****	*****
-0.900	*****	0.2910	0.2649	0.1710	-0.5233	*****	*****	*****	*****	*****
-0.950	0.2285	0.2497	0.2417	0.1781	-0.1884	*****	*****	*****	*****	*****
-0.975	*****	0.1403	0.1602	0.1348	-0.0422	*****	*****	*****	*****	*****
-1.000	-1.1953	-1.0934	-0.8268	-0.7699	-0.3925	*****	*****	*****	*****	*****

Medium Radius L.E.
 Run No. = 6, Point No. = 118
 $C_N = 0.575$, $C_m = -0.1046$
 $\alpha = 12.4^\circ$, $M_\infty = 0.829$
 $R_{mac} = 6.0 \times 10^6$

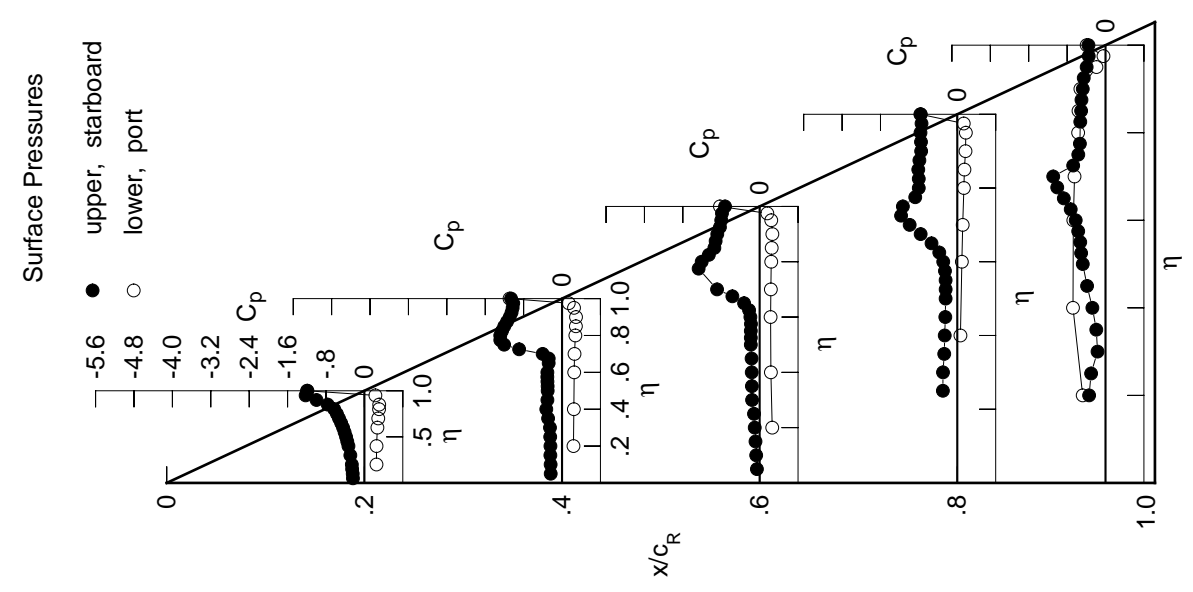
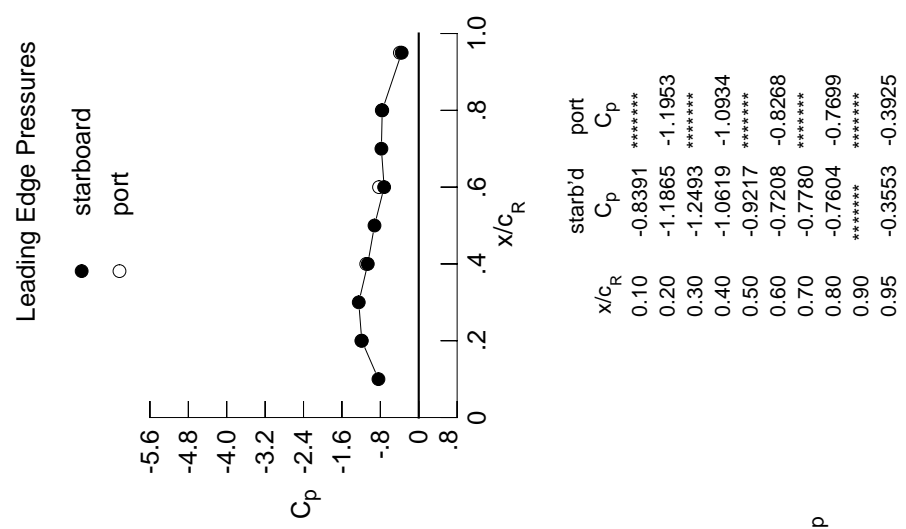
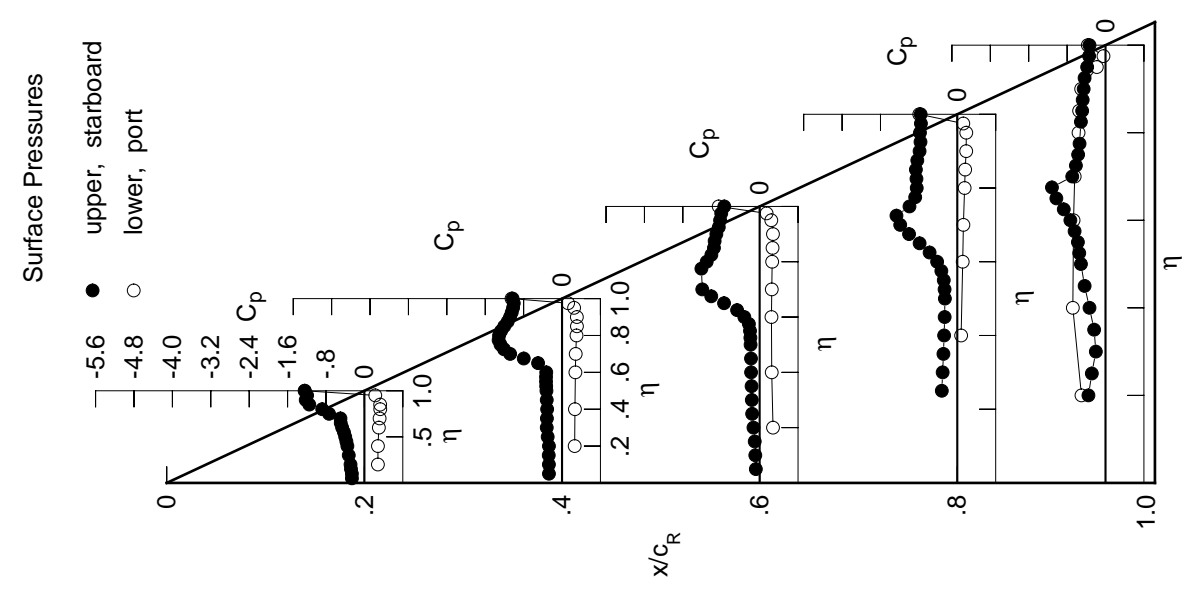
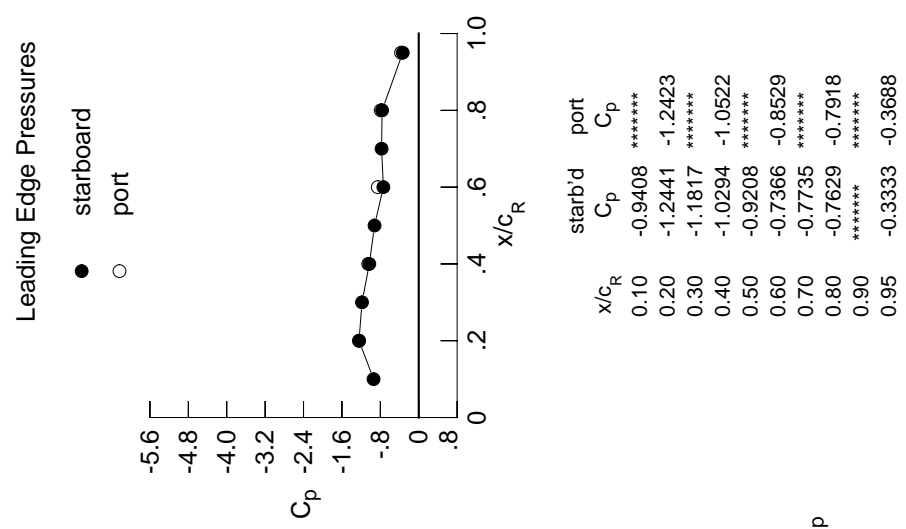

Table F2. Continued.

η	$x/c_R = 0.2$		$x/c_R = 0.4$		$x/c_R = 0.6$		$x/c_R = 0.8$		$x/c_R = 0.95$	
	$C_{p,u}$	$C_{p,l}$	$C_{p,u}$	$C_{p,l}$	$C_{p,u}$	$C_{p,l}$	$C_{p,u}$	$C_{p,l}$	$C_{p,u}$	$C_{p,l}$
0.050	-0.2602	-0.2724	-0.0790	*****	*****	*****	*****	*****	*****	*****
0.100	-0.2610	-0.2740	-0.0906	*****	*****	*****	*****	*****	*****	*****
0.150	-0.2795	-0.2766	-0.1022	*****	*****	*****	*****	*****	*****	*****
0.200	-0.2887	-0.2726	-0.1285	*****	*****	*****	*****	*****	*****	*****
0.250	*****	-0.2991	-0.1559	-0.3225	-0.3225	-0.2849	*****	*****	*****	*****
0.300	-0.3259	-0.3181	-0.1629	-0.3046	-0.2017	*****	*****	*****	*****	*****
0.350	*****	-0.3155	-0.1679	-0.2888	-0.2371	*****	*****	*****	*****	*****
0.400	-0.3543	-0.3105	-0.1782	-0.2744	-0.3340	*****	*****	*****	*****	*****
0.450	-0.3750	-0.3182	-0.1798	-0.2632	-0.4355	*****	*****	*****	*****	*****
0.500	-0.3992	-0.3251	-0.1885	-0.2584	-0.5121	*****	*****	*****	*****	*****
0.525	*****	-0.3303	-0.1932	-0.2650	-0.5470	*****	*****	*****	*****	*****
0.550	-0.4255	-0.3338	-0.2007	-0.2819	-0.5752	*****	*****	*****	*****	*****
0.575	*****	-0.3335	-0.2239	-0.3316	-0.6438	*****	*****	*****	*****	*****
0.600	-0.4633	-0.3287	-0.3195	-0.4197	-0.7320	*****	*****	*****	*****	*****
0.625	*****	*****	-0.4697	-0.5765	-0.8694	*****	*****	*****	*****	*****
0.650	-0.4932	-0.4995	-0.7414	-0.7851	-1.0240	*****	*****	*****	*****	*****
0.675	*****	-0.7980	-1.0080	-1.0044	-1.1159	*****	*****	*****	*****	*****
0.700	-0.4987	-1.0806	-1.1949	-1.1886	-0.6925	*****	*****	*****	*****	*****
0.725	*****	-1.2076	*****	-1.2672	-0.6166	*****	*****	*****	*****	*****
0.750	-0.7359	-1.2809	*****	-0.9961	-0.5708	*****	*****	*****	*****	*****
0.775	*****	-1.3218	-1.2133	-0.8772	-0.5406	*****	*****	*****	*****	*****
0.800	-0.8781	-1.3117	-1.1034	-0.8445	*****	*****	*****	*****	*****	*****
0.825	*****	-1.2680	-1.0057	-0.8501	-0.5128	*****	*****	*****	*****	*****
0.850	-1.1477	-1.2032	-0.9523	-0.8624	-0.4862	*****	*****	*****	*****	*****
0.875	*****	-1.1327	-0.9377	-0.8331	-0.4755	*****	*****	*****	*****	*****
0.900	-1.2227	-1.0833	-0.9016	-0.7857	-0.4552	*****	*****	*****	*****	*****
0.925	*****	-1.0482	-0.8516	-0.7664	-0.4364	*****	*****	*****	*****	*****
0.950	-1.1937	-1.0197	-0.8238	-0.7776	-0.3826	*****	*****	*****	*****	*****
0.975	*****	-1.0053	-0.8001	-0.7578	-0.3418	*****	*****	*****	*****	*****
1.000	-1.2441	-1.0294	-0.7366	-0.7629	-0.3333	*****	*****	*****	*****	*****
-0.200	$C_{p,l}$	0.2820	0.2631	0.2787	*****	-0.5005	$C_{p,l}$	0.2820	0.2631	0.2787
-0.400		0.2824	0.2689	0.2517	0.0797	0.6808		0.2824	0.2689	0.2517
-0.600		0.3020	0.2782	0.2460	0.1131	0.6659		0.3020	0.2782	0.2460
-0.700		0.3167	0.2846	0.2526	0.1271	0.6420		0.3167	0.2846	0.2526
-0.800		0.3301	0.3013	0.2610	0.1525	0.5617		0.3301	0.3013	0.2610
-0.850		0.3290	0.3103	0.2685	0.1642	0.5494		0.3290	0.3103	0.2685
-0.900	*****	0.3086	0.3086	0.2776	0.1853	0.5074	*****	0.3086	0.3086	0.2776
-0.950	0.2268	0.2511	0.2425	0.1874	-0.1807	*****	0.2268	0.2511	0.2425	0.1874
-0.975	*****	0.1265	0.1265	0.1444	0.1245	-0.0425	*****	0.1265	0.1265	0.1444
-1.000	-1.2423	-1.0522	-0.8529	-0.7918	-0.3688	*****	-1.2423	-1.0522	-0.8529	-0.7918

Medium Radius L.E.
 Run No. = 6, Point No. = 119
 $C_N = 0.626$, $C_m = -0.1089$
 $\alpha = 13.4^\circ$, $M_\infty = 0.829$
 $R_{mac} = 6.0 \times 10^6$



x/c_R	starb'd C_p	port C_p
0.10	-0.9408	*****
0.20	-1.2441	-1.2423
0.30	-1.1817	*****
0.40	-1.0294	-1.0522
0.50	-0.9208	*****
0.60	-0.7366	-0.8529
0.70	-0.7735	*****
0.80	-0.7629	-0.7918
0.90	*****	*****
0.95	-0.3333	-0.3688

Table F2. Continued.

η	$x/c_R = .2$		$x/c_R = .4$		$x/c_R = .6$		$x/c_R = .8$		$x/c_R = .95$	
	$C_{p,u}$	$C_{p,u}$	$C_{p,u}$	$C_{p,u}$	$C_{p,u}$	$C_{p,u}$	$C_{p,u}$	$C_{p,u}$	$C_{p,u}$	$C_{p,u}$
0.050	-0.2841	-0.3095	-0.1012	*****	*****	*****	*****	*****	*****	*****
0.100	-0.2809	-0.3083	-0.1091	*****	*****	*****	*****	*****	*****	*****
0.150	-0.3031	-0.3114	-0.1243	*****	*****	*****	*****	*****	*****	*****
0.200	-0.3227	-0.3210	-0.1596	*****	*****	*****	*****	*****	*****	*****
0.250	*****	-0.3504	-0.1654	-0.3422	-0.3422	-0.2485	*****	*****	*****	*****
0.300	-0.3489	-0.3356	-0.1747	-0.3190	-0.2186	*****	*****	*****	*****	*****
0.350	*****	-0.3345	-0.1838	-0.3041	-0.2733	*****	*****	*****	*****	*****
0.400	-0.3806	-0.3406	-0.1940	-0.2912	-0.3801	*****	*****	*****	*****	*****
0.450	-0.3942	-0.3447	-0.1949	-0.2842	-0.4746	*****	*****	*****	*****	*****
0.500	-0.4154	-0.3448	-0.2139	-0.3010	-0.5544	*****	*****	*****	*****	*****
0.525	*****	-0.3456	-0.2313	-0.3246	-0.6056	*****	*****	*****	*****	*****
0.550	-0.4403	-0.3507	-0.2701	-0.3763	-0.6651	*****	*****	*****	*****	*****
0.575	*****	-0.3685	-0.3503	-0.4698	-0.7685	*****	*****	*****	*****	*****
0.600	-0.4565	-0.4252	-0.5353	-0.6102	-0.8887	*****	*****	*****	*****	*****
0.625	*****	*****	-0.7500	-0.7927	-1.0397	*****	*****	*****	*****	*****
0.650	-0.4429	-0.9258	-1.0111	-0.9912	-1.0853	*****	*****	*****	*****	*****
0.675	*****	-1.2063	-1.2190	-1.1756	-0.6589	*****	*****	*****	*****	*****
0.700	-0.6741	-1.3497	-1.3571	-1.2351	-0.6103	*****	*****	*****	*****	*****
0.725	*****	-1.3474	*****	-0.9344	-0.5677	*****	*****	*****	*****	*****
0.750	-1.0772	-1.3500	*****	-0.8771	-0.5290	*****	*****	*****	*****	*****
0.775	*****	-1.3819	-1.0964	-0.8610	-0.5093	*****	*****	*****	*****	*****
0.800	-1.1665	-1.3382	-1.0267	-0.8693	*****	*****	*****	*****	*****	*****
0.825	*****	-1.2602	-1.0024	-0.8887	-0.4777	*****	*****	*****	*****	*****
0.850	-1.2831	-1.1844	-0.9967	-0.8943	-0.4478	*****	*****	*****	*****	*****
0.875	*****	-1.1214	-0.9842	-0.8487	-0.4343	*****	*****	*****	*****	*****
0.900	-1.2499	-1.0846	-0.9241	-0.8146	-0.4135	*****	*****	*****	*****	*****
0.925	*****	-1.0535	-0.8816	-0.8107	-0.3946	*****	*****	*****	*****	*****
0.950	-1.2016	-1.0250	-0.8673	-0.8162	-0.3524	*****	*****	*****	*****	*****
0.975	*****	-1.0147	-0.8459	-0.7972	-0.3220	*****	*****	*****	*****	*****
1.000	-1.2900	-1.0275	-0.7772	-0.7980	-0.3189	*****	*****	*****	*****	*****
-0.200	$C_{p,l}$	$C_{p,l}$	$C_{p,l}$	$C_{p,l}$	$C_{p,l}$	$C_{p,l}$	$C_{p,l}$	$C_{p,l}$	$C_{p,l}$	$C_{p,l}$
-0.400	0.3076	0.2832	0.2940	*****	-0.5417	*****	*****	*****	*****	*****
-0.600	0.3102	0.2908	0.2673	0.0924	-0.6799	*****	*****	*****	*****	*****
-0.700	0.3254	0.2991	0.2635	0.1228	-0.6621	*****	*****	*****	*****	*****
-0.800	0.3397	0.3065	0.2693	0.1415	-0.6322	*****	*****	*****	*****	*****
-0.850	0.3475	0.3203	0.2767	0.1661	-0.5524	*****	*****	*****	*****	*****
-0.900	0.3433	0.3244	0.2841	0.1766	-0.5394	*****	*****	*****	*****	*****
-0.950	0.2197	0.2454	0.2395	0.1856	-0.1744	*****	*****	*****	*****	*****
-0.975	*****	0.1048	0.1296	0.1109	-0.0453	*****	*****	*****	*****	*****
-1.000	-1.2717	-1.0654	-0.8585	-0.8142	-0.3476	*****	*****	*****	*****	*****

Medium Radius L.E.
 Run No. = 6, Point No. = 120
 $C_N = 0.672$, $C_m = -0.1114$
 $\alpha = 14.4^\circ$, $M_\infty = 0.829$
 $R_{mac} = 6.0 \times 10^6$

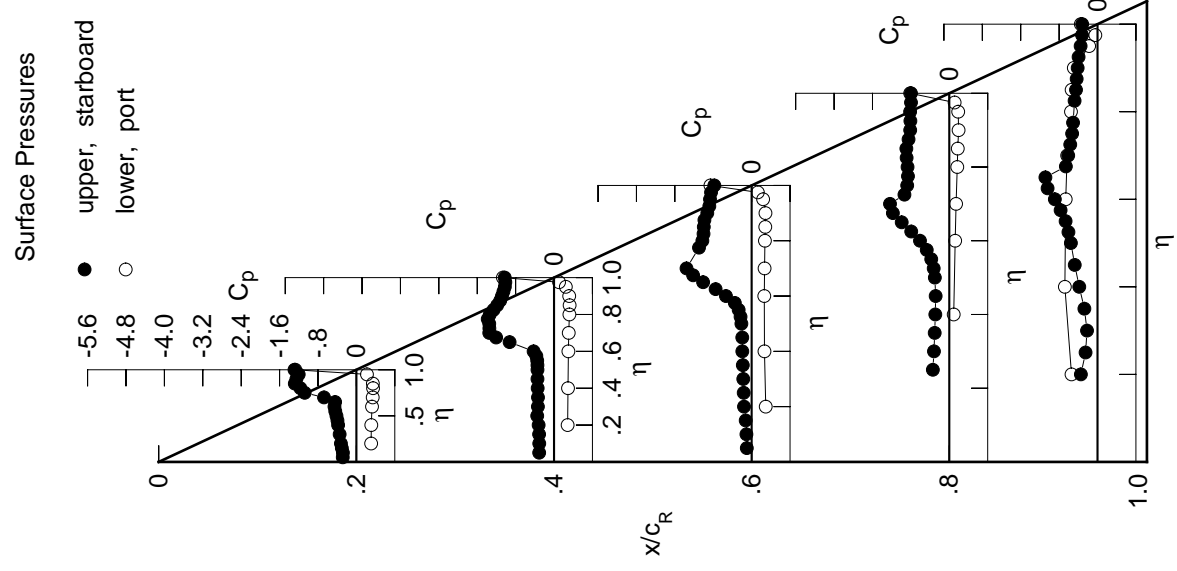
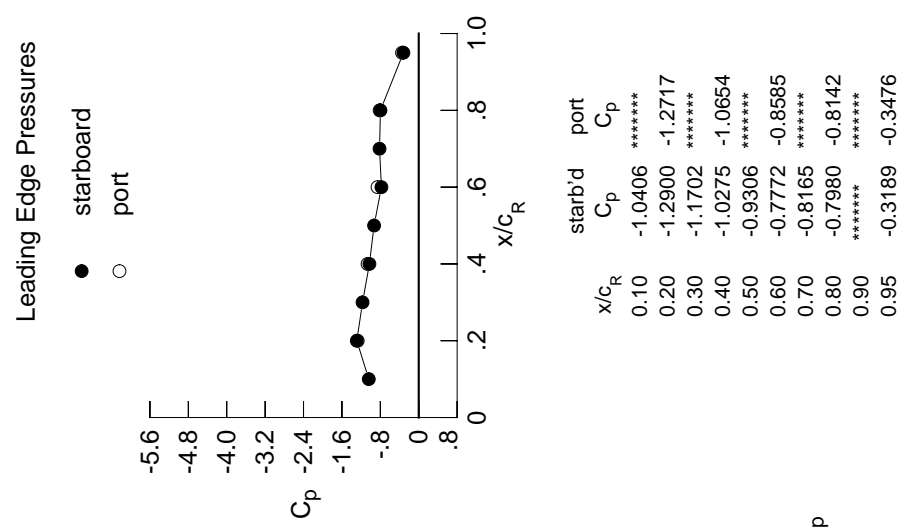

Table F2. Continued.

η	$x/c_R = .2$		$x/c_R = .4$		$x/c_R = .6$		$x/c_R = .8$		$x/c_R = .95$	
	$C_{p,u}$	$C_{p,u}$	$C_{p,u}$	$C_{p,u}$	$C_{p,u}$	$C_{p,u}$	$C_{p,u}$	$C_{p,u}$	$C_{p,u}$	$C_{p,u}$
0.050	-0.3367	-0.3808	-0.1422	*****	*****	*****	*****	*****	*****	*****
0.100	-0.3305	-0.3770	-0.1523	*****	*****	*****	*****	*****	*****	*****
0.150	-0.3607	-0.3880	-0.1733	*****	*****	*****	*****	*****	*****	*****
0.200	-0.3996	-0.4047	-0.1956	*****	*****	*****	*****	*****	*****	*****
0.250	*****	-0.3991	-0.2049	-0.3908	-0.3652	*****	*****	*****	*****	*****
0.300	-0.3941	-0.3977	-0.2179	-0.3727	-0.3368	*****	*****	*****	*****	*****
0.350	*****	-0.4000	-0.2311	-0.3623	-0.3734	*****	*****	*****	*****	*****
0.400	-0.4148	-0.4027	-0.2495	-0.3606	-0.4568	*****	*****	*****	*****	*****
0.450	-0.4376	-0.4062	-0.2697	-0.3850	-0.5487	*****	*****	*****	*****	*****
0.500	-0.4490	-0.4193	-0.3595	-0.4686	-0.6737	*****	*****	*****	*****	*****
0.525	*****	-0.4487	-0.4439	-0.5496	-0.7605	*****	*****	*****	*****	*****
0.550	-0.4385	-0.5214	-0.5721	-0.6625	-0.8676	*****	*****	*****	*****	*****
0.575	*****	-0.6651	-0.7395	-0.8107	-1.0037	*****	*****	*****	*****	*****
0.600	-0.3704	-0.8867	-0.9654	-0.9701	-1.0990	*****	*****	*****	*****	*****
0.625	*****	*****	-1.1543	-1.1280	-0.6617	*****	*****	*****	*****	*****
0.650	-0.9752	-1.3776	-1.3288	-1.2783	-0.6212	*****	*****	*****	*****	*****
0.675	*****	-1.5273	-1.4598	-1.0693	-0.6104	*****	*****	*****	*****	*****
0.700	-1.4242	-1.6058	-1.2543	-0.9269	-0.5921	*****	*****	*****	*****	*****
0.725	*****	-1.5929	*****	-0.9053	-0.5661	*****	*****	*****	*****	*****
0.750	-1.4456	-1.4786	*****	-0.9122	-0.5335	*****	*****	*****	*****	*****
0.775	*****	-1.4315	-1.1075	-0.9114	-0.5067	*****	*****	*****	*****	*****
0.800	-1.4077	-1.3303	-1.1063	-0.9311	*****	*****	*****	*****	*****	*****
0.825	*****	-1.2328	-1.1262	-0.9396	-0.4473	*****	*****	*****	*****	*****
0.850	-1.3582	-1.1976	-1.1101	-0.9128	-0.4110	*****	*****	*****	*****	*****
0.875	*****	-1.1769	-1.0346	-0.8733	-0.3996	*****	*****	*****	*****	*****
0.900	-1.2700	-1.1475	-0.9793	-0.8593	-0.3827	*****	*****	*****	*****	*****
0.925	*****	-1.0969	-0.9729	-0.8600	-0.3786	*****	*****	*****	*****	*****
0.950	-1.2433	-1.0714	-0.9709	-0.8626	-0.3460	*****	*****	*****	*****	*****
0.975	*****	-1.0623	-0.9527	-0.8432	-0.3282	*****	*****	*****	*****	*****
1.000	-1.3230	-1.0591	-0.8647	-0.8350	-0.3291	*****	*****	*****	*****	*****
	$C_{p,l}$	$C_{p,l}$	$C_{p,l}$	$C_{p,l}$	$C_{p,l}$	$C_{p,l}$	$C_{p,l}$	$C_{p,l}$	$C_{p,l}$	$C_{p,l}$
-0.200	0.3600	0.3303	0.3278	*****	-0.5596	*****	*****	*****	*****	*****
-0.400	0.3657	0.3354	0.3018	0.1228	-0.6657	*****	*****	*****	*****	*****
-0.600	0.3829	0.3435	0.2982	0.1498	-0.6451	*****	*****	*****	*****	*****
-0.700	0.3929	0.3494	0.3022	0.1716	-0.6155	*****	*****	*****	*****	*****
-0.800	0.3904	0.3589	0.3076	0.1924	-0.5307	*****	*****	*****	*****	*****
-0.850	0.3764	0.3573	0.3114	0.2024	-0.5152	*****	*****	*****	*****	*****
-0.900	*****	0.3356	0.3050	0.2143	-0.4650	*****	*****	*****	*****	*****
-0.950	0.2086	0.2386	0.2285	0.1806	-0.1630	*****	*****	*****	*****	*****
-0.975	*****	0.0689	0.0871	0.0827	-0.0562	*****	*****	*****	*****	*****
-1.000	-1.3342	-1.0791	-0.9539	-0.8498	-0.3515	*****	*****	*****	*****	*****

Medium Radius L.E.
 Run No. = 6, Point No. = 121
 $C_N = 0.781$, $C_m = -0.1285$
 $\alpha = 16.5^\circ$, $M_\infty = 0.828$
 $R_{mac} = 6.0 \times 10^6$

Leading Edge Pressures

● starboard
 ○ port

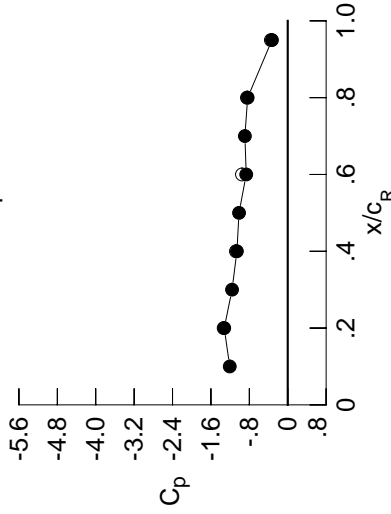

x/c_R	starb'd C_p	port C_p
0.10	-1.2082	*****
0.20	-1.3230	*****
0.30	-1.1597	*****
0.40	-1.0591	*****
0.50	-1.0147	*****
0.60	-0.8647	-0.9539
0.70	-0.8925	*****
0.80	-0.8350	-0.8498
0.90	*****	*****
0.95	-0.3291	-0.3515

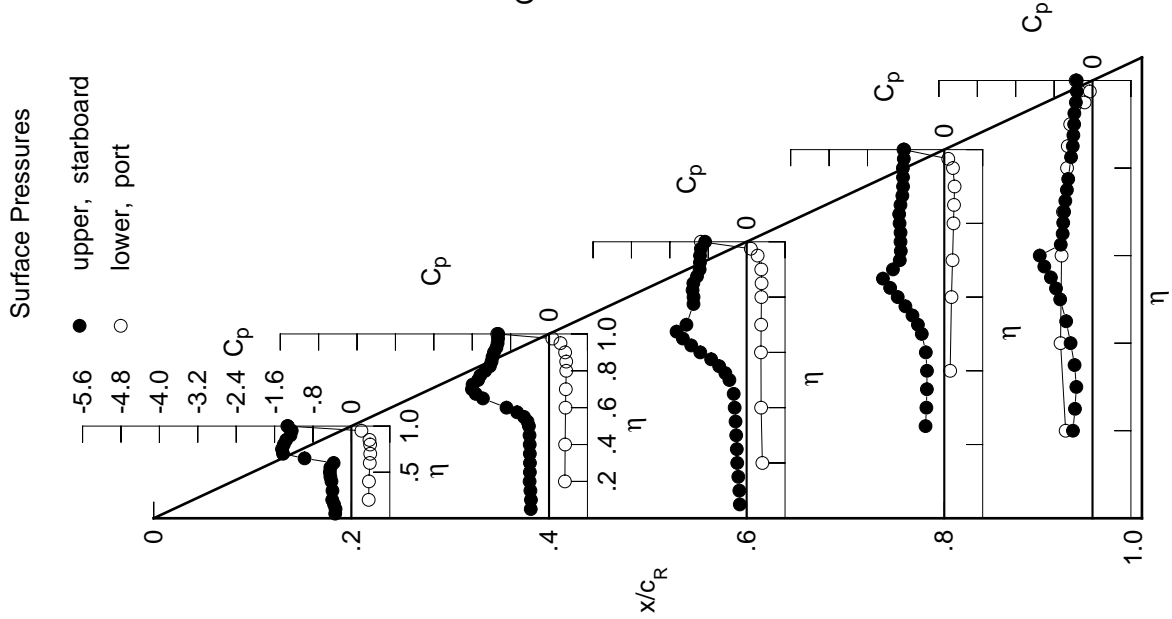
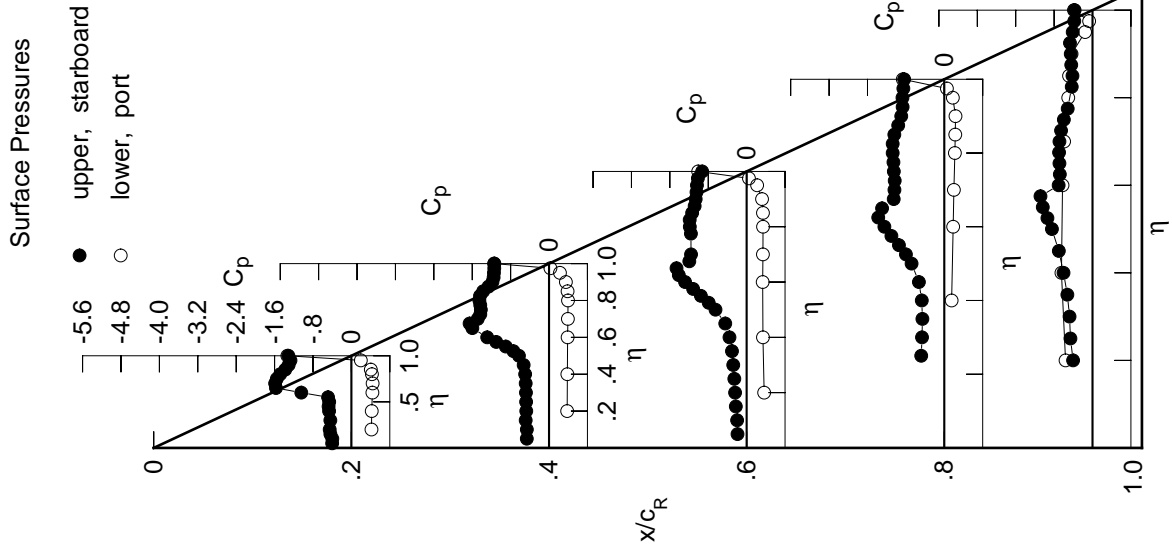

Table F2. Continued.

η	$x/c_R = .2$		$x/c_R = .4$		$x/c_R = .6$		$x/c_R = .8$		$x/c_R = .95$	
	$C_{p,u}$	$C_{p,u}$	$C_{p,u}$	$C_{p,u}$	$C_{p,u}$	$C_{p,u}$	$C_{p,u}$	$C_{p,u}$	$C_{p,u}$	$C_{p,u}$
0.050	-0.4006	-0.4633	-0.1904	*****	*****	*****	*****	*****	*****	*****
0.100	-0.3976	-0.4622	-0.1985	*****	*****	*****	*****	*****	*****	*****
0.150	-0.4373	-0.4862	-0.2253	*****	*****	*****	*****	*****	*****	*****
0.200	-0.4517	-0.4744	-0.2410	*****	*****	*****	*****	*****	*****	-0.4045
0.250	*****	-0.4775	-0.2566	-0.4804	-0.4597	*****	*****	*****	*****	*****
0.300	-0.4388	-0.4810	-0.2792	-0.4637	-0.4783	*****	*****	*****	*****	*****
0.350	*****	-0.4864	-0.3052	-0.4559	-0.5238	*****	*****	*****	*****	*****
0.400	-0.4650	-0.4977	-0.3577	-0.4688	-0.6041	*****	*****	*****	*****	*****
0.450	-0.4752	-0.5287	-0.4458	-0.5291	-0.7017	*****	*****	*****	*****	*****
0.500	-0.4625	-0.6273	-0.6491	-0.6812	-0.8459	*****	*****	*****	*****	*****
0.525	*****	-0.7414	-0.7902	-0.7991	-0.9390	*****	*****	*****	*****	*****
0.550	-0.4866	-0.9006	-0.9527	-0.9450	-1.0364	*****	*****	*****	*****	*****
0.575	*****	-1.0998	-1.1148	-1.1015	-1.0838	*****	*****	*****	*****	*****
0.600	-1.0440	-1.2877	-1.2824	-1.2482	-0.7055	*****	*****	*****	*****	*****
0.625	*****	*****	-1.4125	-1.3762	-0.6805	*****	*****	*****	*****	*****
0.650	-1.5714	-1.5977	-1.4610	-1.2960	-0.6888	*****	*****	*****	*****	*****
0.675	*****	-1.6551	-1.1946	-1.0533	-0.6971	*****	*****	*****	*****	*****
0.700	-1.5887	-1.4852	-1.1580	-1.0387	-0.6886	*****	*****	*****	*****	*****
0.725	*****	-1.4316	*****	-1.0326	-0.6553	*****	*****	*****	*****	*****
0.750	-1.5537	-1.4210	*****	-1.0513	-0.5964	*****	*****	*****	*****	*****
0.775	*****	-1.4324	-1.1612	-1.0590	-0.5172	*****	*****	*****	*****	*****
0.800	-1.4826	-1.4512	-1.1837	-1.0756	*****	*****	*****	*****	*****	*****
0.825	*****	-1.4378	-1.1863	-1.0749	-0.4326	*****	*****	*****	*****	*****
0.850	-1.3777	-1.3720	-1.1354	-1.0406	-0.4173	*****	*****	*****	*****	*****
0.875	*****	-1.2614	-1.0833	-0.9600	-0.4435	*****	*****	*****	*****	*****
0.900	-1.3069	-1.1791	-1.0619	-0.8967	-0.4539	*****	*****	*****	*****	*****
0.925	*****	-1.1543	-1.0452	-0.8678	-0.4698	*****	*****	*****	*****	*****
0.950	-1.2689	-1.1479	-1.0352	-0.8712	-0.4129	*****	*****	*****	*****	*****
0.975	*****	-1.1411	-1.0162	-0.8524	-0.3799	*****	*****	*****	*****	*****
1.000	-1.3125	-1.1391	-0.9262	-0.8360	-0.3724	*****	*****	*****	*****	*****
-0.200	$C_{p,l}$	$C_{p,l}$	$C_{p,l}$	$C_{p,l}$	$C_{p,l}$	$C_{p,l}$	$C_{p,l}$	$C_{p,l}$	$C_{p,l}$	$C_{p,l}$
-0.400	0.4184	0.3779	0.3649	*****	*****	*****	*****	*****	*****	-0.5619
-0.600	0.4236	0.3819	0.3396	0.1530	0.6469	*****	*****	*****	*****	*****
-0.700	0.4375	0.3870	0.3341	0.1848	-0.6247	*****	*****	*****	*****	*****
-0.800	0.4422	0.3931	0.3396	0.2002	-0.5923	*****	*****	*****	*****	*****
-0.850	0.4281	0.3955	0.3413	0.2205	-0.5059	*****	*****	*****	*****	*****
-0.900	0.4045	0.3867	0.3399	0.2288	-0.4886	*****	*****	*****	*****	*****
-0.950	*****	0.3509	0.3210	0.2334	-0.4368	*****	*****	*****	*****	*****
-0.975	0.1967	0.2275	0.2185	0.1784	-0.1548	*****	*****	*****	*****	*****
-1.000	-1.3333	-1.1433	-1.0099	-0.8646	-0.3862	*****	*****	*****	*****	*****



Medium Radius L.E.
 Run No. = 6, Point No. = 122
 $C_N = 0.895$, $C_m = -0.1486$
 $\alpha = 18.5^\circ$, $M_\infty = 0.828$
 $R_{mac} = 6.0 \times 10^6$

Leading Edge Pressures

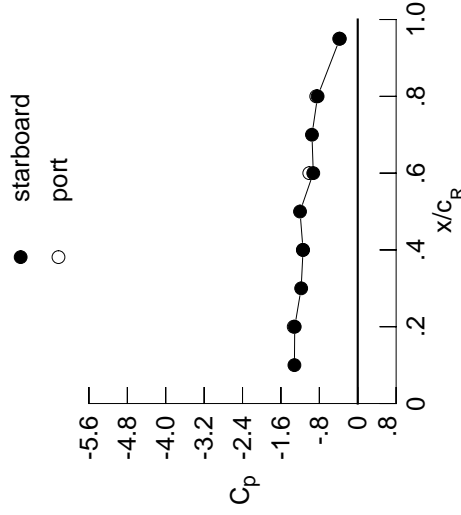

x/c_R	starb'd C_p	port C_p
0.10	-1.3191	*****
0.20	-1.3125	-1.3333
0.30	-1.1786	*****
0.40	-1.1391	-1.1433
0.50	-1.2024	*****
0.60	-0.9262	-1.0099
0.70	-0.9534	*****
0.80	-0.8360	-0.8646
0.90	*****	*****
0.95	-0.3724	-0.3862

Table F2. Continued.

η	$x/c_R = .2$		$x/c_R = .4$		$x/c_R = .6$		$x/c_R = .8$		$x/c_R = .95$	
	$C_{p,u}$	$C_{p,u}$	$C_{p,u}$	$C_{p,u}$	$C_{p,u}$	$C_{p,u}$	$C_{p,u}$	$C_{p,u}$	$C_{p,u}$	$C_{p,u}$
0.050	-0.4647	-0.5255	-0.2291	*****	*****	*****	*****	*****	*****	*****
0.100	-0.4704	-0.5219	-0.2400	*****	*****	*****	*****	*****	*****	*****
0.150	-0.5059	-0.5494	-0.2658	*****	*****	*****	*****	*****	*****	*****
0.200	-0.4968	-0.5351	-0.3032	*****	*****	*****	*****	*****	*****	-0.3976
0.250	*****	-0.5448	-0.3225	-0.5518	-0.5260	*****	*****	*****	*****	-0.5260
0.300	-0.4950	-0.5548	-0.3641	-0.5497	-0.6007	*****	*****	*****	*****	-0.6007
0.350	*****	-0.5712	-0.4212	-0.5628	-0.6706	*****	*****	*****	*****	-0.6706
0.400	-0.5283	-0.6157	-0.5293	-0.6121	-0.7524	*****	*****	*****	*****	-0.7524
0.450	-0.5383	-0.7153	-0.7081	-0.7219	-0.8598	*****	*****	*****	*****	-0.8598
0.500	-0.5961	-0.9192	-0.9810	-0.9131	-1.0259	*****	*****	*****	*****	-1.0259
0.525	*****	-1.0730	-1.1303	-1.0382	-1.1110	*****	*****	*****	*****	-1.1110
0.550	-0.9725	-1.2324	-1.2705	-1.1651	-1.0604	*****	*****	*****	*****	-1.0604
0.575	*****	-1.3880	-1.3946	-1.2938	-0.6971	*****	*****	*****	*****	-0.6971
0.600	-1.5364	-1.5134	-1.5107	-1.4044	-0.6723	*****	*****	*****	*****	-0.6723
0.625	*****	*****	-1.5764	-1.4848	-0.6843	*****	*****	*****	*****	-0.6843
0.650	-1.7678	-1.5172	-1.3077	-1.1381	-0.6940	*****	*****	*****	*****	-0.6940
0.675	*****	-1.4020	-1.2686	-1.0981	-0.6629	*****	*****	*****	*****	-0.6629
0.700	-1.7428	-1.3838	-1.2602	-1.0936	-0.6004	*****	*****	*****	*****	-0.6004
0.725	*****	-1.3878	*****	-1.0940	-0.5360	*****	*****	*****	*****	-0.5360
0.750	-1.6563	-1.3980	*****	-1.1125	-0.4949	*****	*****	*****	*****	-0.4949
0.775	*****	-1.4335	-1.2551	-1.1352	-0.4843	*****	*****	*****	*****	-0.4843
0.800	-1.5307	-1.4695	-1.2720	-1.1725	*****	*****	*****	*****	*****	*****
0.825	*****	-1.4255	-1.2723	-1.1791	-0.5215	*****	*****	*****	*****	-0.5215
0.850	-1.3990	-1.3381	-1.2230	-1.1450	-0.5134	*****	*****	*****	*****	-0.5134
0.875	*****	-1.2861	-1.1737	-1.0346	-0.5239	*****	*****	*****	*****	-0.5239
0.900	-1.3259	-1.2816	-1.1571	-0.9366	-0.5187	*****	*****	*****	*****	-0.5187
0.925	*****	-1.2859	-1.1607	-0.8981	-0.5357	*****	*****	*****	*****	-0.5357
0.950	-1.2798	-1.2835	-1.1595	-0.9064	-0.4631	*****	*****	*****	*****	-0.4631
0.975	*****	-1.2762	-1.1416	-0.8889	-0.4291	*****	*****	*****	*****	-0.4291
1.000	-1.3021	-1.2866	-1.0320	-0.8613	-0.4207	*****	*****	*****	*****	-0.4207
-0.200	$C_{p,l}$	$C_{p,l}$	$C_{p,l}$	$C_{p,l}$	$C_{p,l}$	$C_{p,l}$	$C_{p,l}$	$C_{p,l}$	$C_{p,l}$	$C_{p,l}$
-0.400	0.4748	0.4249	0.4033	*****	-0.5545	*****	*****	*****	*****	-0.5545
-0.600	0.4797	0.4275	0.3779	0.1873	0.6240	*****	*****	*****	*****	0.6240
-0.700	0.4888	0.4351	0.3730	0.2154	-0.6004	*****	*****	*****	*****	-0.6004
-0.800	0.4631	0.4338	0.3708	0.2480	-0.4783	*****	*****	*****	*****	-0.4783
-0.850	0.4297	0.4136	0.3642	0.2523	-0.4625	*****	*****	*****	*****	-0.4625
-0.900	*****	0.3612	0.3331	0.2487	-0.4108	*****	*****	*****	*****	-0.4108
-0.950	0.1809	0.2109	0.2037	0.1755	-0.1488	*****	*****	*****	*****	-0.1488
-0.975	*****	-0.0149	0.0069	0.0233	-0.0902	*****	*****	*****	*****	-0.0902
-1.000	-1.3445	-1.3219	-1.1314	-0.8851	-0.4394	*****	*****	*****	*****	-0.4394

Medium Radius L.E.
 Run No. = 6, Point No. = 123
 $C_N = 1.008$, $C_m = -0.1708$
 $\alpha = 20.6^\circ$, $M_\infty = 0.829$
 $R_{mac} = 6.0 \times 10^6$

Leading Edge Pressures

● starboard
 ○ port

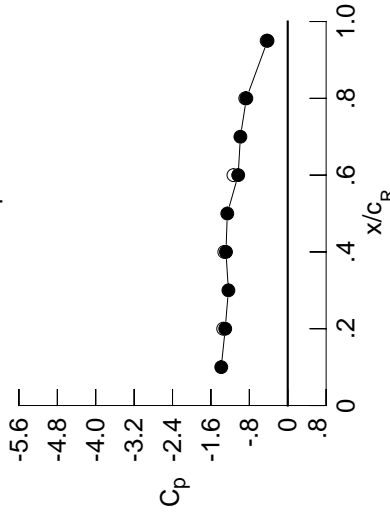

x/c_R	starb'd C_p	port C_p
0.10	-1.3852	*****
0.20	-1.3021	-1.3445
0.30	-1.2362	*****
0.40	-1.2866	-1.3219
0.50	-1.2590	*****
0.60	-1.0320	-1.1314
0.70	-0.9863	*****
0.80	-0.8613	-0.8851
0.90	*****	*****
0.95	-0.4207	-0.4394

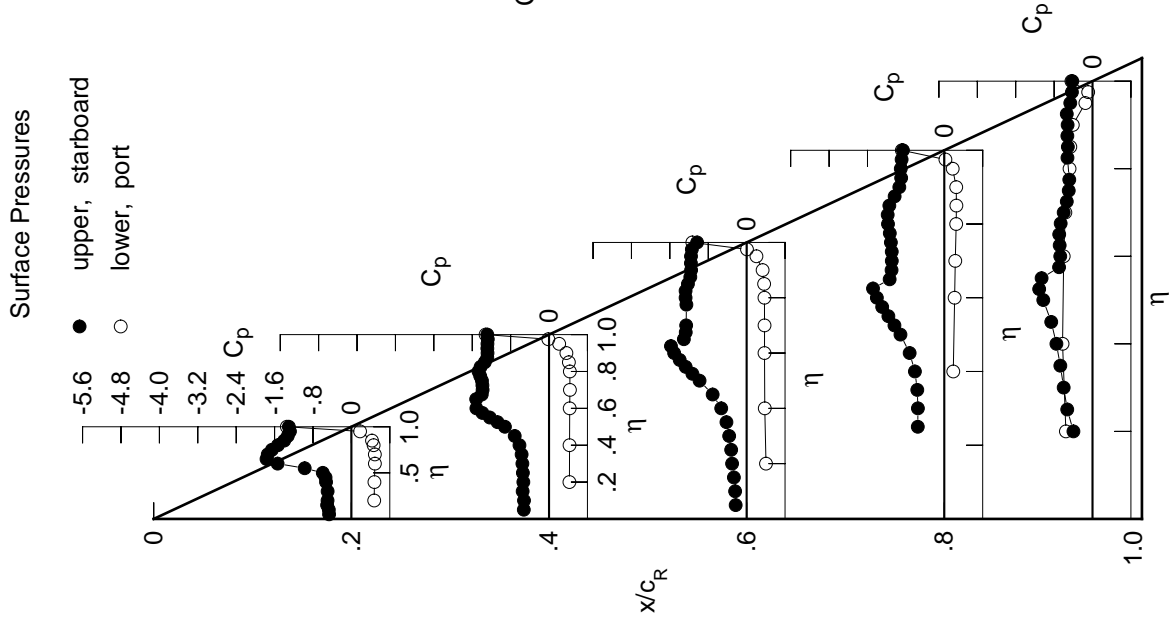
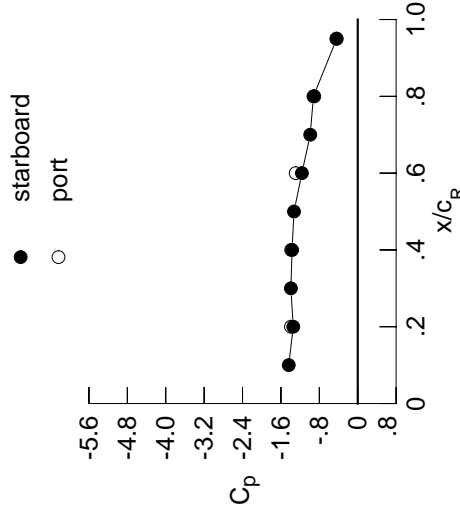

Table F2. Continued.

η	$x/c_R = .2$		$x/c_R = .4$		$x/c_R = .6$		$x/c_R = .8$		$x/c_R = .95$	
	$C_{p,u}$	$C_{p,l}$	$C_{p,u}$	$C_{p,l}$	$C_{p,u}$	$C_{p,l}$	$C_{p,u}$	$C_{p,l}$	$C_{p,u}$	$C_{p,l}$
0.050	-0.5307	-0.6023	-0.5100	*****	*****	*****	*****	*****	*****	*****
0.100	-0.5407	-0.6006	-0.5259	*****	*****	*****	*****	*****	*****	*****
0.150	-0.5714	-0.6085	-0.5493	*****	*****	*****	*****	*****	*****	*****
0.200	-0.5613	-0.6302	-0.5692	*****	*****	*****	*****	*****	*****	*****
0.250	*****	-0.6397	-0.5937	-0.6571	-0.6943	*****	*****	*****	*****	*****
0.300	-0.5654	-0.6635	-0.6307	-0.6690	-0.5774	*****	*****	*****	*****	*****
0.350	*****	-0.7158	-0.6990	-0.7039	-0.6394	*****	*****	*****	*****	*****
0.400	-0.6082	-0.8079	-0.8220	-0.7832	-0.7395	*****	*****	*****	*****	*****
0.450	-0.6941	-0.9732	-1.0211	-0.9179	-0.8827	*****	*****	*****	*****	*****
0.500	-0.9649	-1.1995	-1.2756	-1.1194	-1.0901	*****	*****	*****	*****	*****
0.525	*****	-1.3276	-1.3979	-1.2277	-1.1884	*****	*****	*****	*****	*****
0.550	-1.4075	-1.4448	-1.5065	-1.3380	-0.9540	*****	*****	*****	*****	*****
0.575	*****	-1.5547	-1.5961	-1.4386	-0.7137	*****	*****	*****	*****	*****
0.600	-1.7193	-1.6322	-1.6758	-1.5201	-0.6921	*****	*****	*****	*****	*****
0.625	*****	*****	-1.5401	-1.2311	-0.6721	*****	*****	*****	*****	*****
0.650	-1.7733	-1.4320	-1.4245	-1.1314	-0.6434	*****	*****	*****	*****	*****
0.675	*****	-1.4274	-1.4186	-1.1100	-0.6206	*****	*****	*****	*****	*****
0.700	-1.7707	-1.4222	-1.4152	-1.1125	-0.6010	*****	*****	*****	*****	*****
0.725	*****	-1.4295	*****	-1.1183	-0.5672	*****	*****	*****	*****	*****
0.750	-1.7745	-1.4436	*****	-1.1316	-0.5493	*****	*****	*****	*****	*****
0.775	*****	-1.4681	-1.4585	-1.1571	-0.5514	*****	*****	*****	*****	*****
0.800	-1.5450	-1.4554	-1.4818	-1.2035	*****	*****	*****	*****	*****	*****
0.825	*****	-1.4127	-1.4758	-1.2190	-0.5627	*****	*****	*****	*****	*****
0.850	-1.3970	-1.3897	-1.4171	-1.1904	-0.5368	*****	*****	*****	*****	*****
0.875	*****	-1.3815	-1.3327	-1.0724	-0.5305	*****	*****	*****	*****	*****
0.900	-1.3548	-1.3858	-1.2954	-0.9696	-0.5172	*****	*****	*****	*****	*****
0.925	*****	-1.3789	-1.2860	-0.9441	-0.5224	*****	*****	*****	*****	*****
0.950	-1.3272	-1.3707	-1.2886	-0.9687	-0.4778	*****	*****	*****	*****	*****
0.975	*****	-1.3579	-1.2763	-0.9548	-0.4489	*****	*****	*****	*****	*****
1.000	-1.3434	-1.3681	-1.1627	-0.9219	-0.4388	*****	*****	*****	*****	*****
-0.200	$C_{p,l}$	0.4723	0.4386	*****	-0.5347	*****	*****	*****	*****	*****
-0.400	0.5331	0.4719	0.4176	0.2169	-0.6015	*****	*****	*****	*****	*****
-0.600	0.5382	0.4752	0.4076	0.2449	-0.5744	*****	*****	*****	*****	*****
-0.700	0.5308	0.4738	0.4062	0.2572	-0.5407	*****	*****	*****	*****	*****
-0.800	0.4917	0.4618	0.3989	0.2716	-0.4549	*****	*****	*****	*****	*****
-0.850	0.4493	0.4358	0.3862	0.2719	-0.4386	*****	*****	*****	*****	*****
-0.900	*****	0.3699	0.3419	0.2605	-0.3854	*****	*****	*****	*****	*****
-0.950	0.1634	0.1947	0.1875	0.1637	-0.1414	*****	*****	*****	*****	*****
-0.975	*****	-0.0559	-0.0334	-0.0106	-0.1039	*****	*****	*****	*****	*****
-1.000	-1.3909	-1.3853	-1.2918	-0.9060	-0.4439	*****	*****	*****	*****	*****

Medium Radius L.E.
 Run No. = 6, Point No. = 124
 $C_N = 1.113$, $C_m = -0.1859$
 $\alpha = 22.6^\circ$, $M_\infty = 0.829$
 $R_{mac} = 6.0 \times 10^6$

Leading Edge Pressures



x/c_R	starb'd C_p	port C_p
0.10	-1.4367	*****
0.20	-1.3434	-1.3909
0.30	-1.3923	*****
0.40	-1.3681	-1.3853
0.50	-1.3276	*****
0.60	-1.1627	-1.2918
0.70	-0.9899	*****
0.80	-0.9219	-0.9060
0.90	*****	*****
0.95	-0.4388	-0.4439

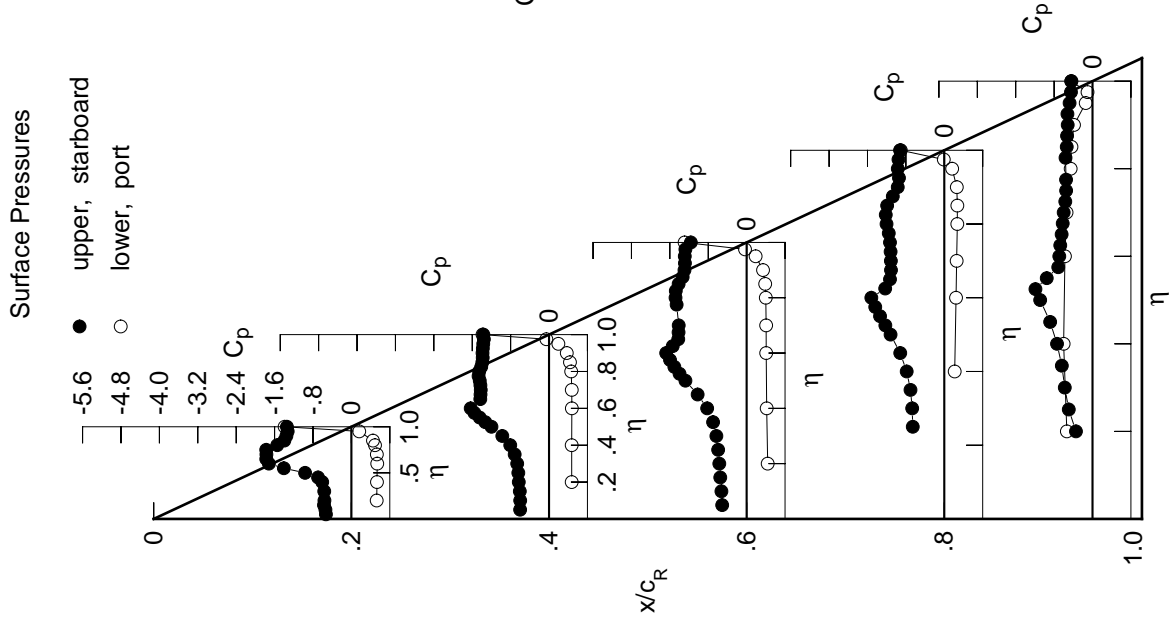
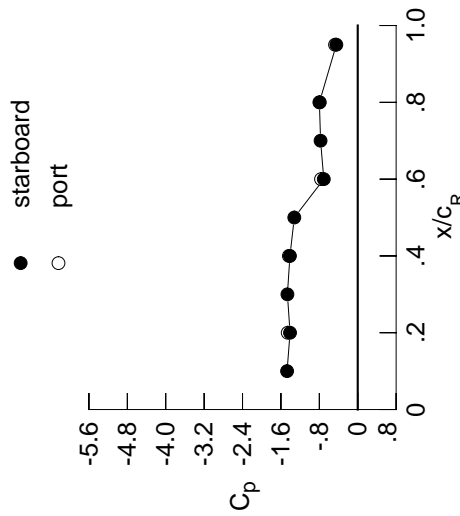

Table F2. Continued.

η	$x/c_R = .2$		$x/c_R = .4$		$x/c_R = .6$		$x/c_R = .8$		$x/c_R = .95$	
	$C_{p,u}$	$C_{p,u}$	$C_{p,u}$	$C_{p,u}$	$C_{p,u}$	$C_{p,u}$	$C_{p,u}$	$C_{p,u}$	$C_{p,u}$	$C_{p,u}$
0.050	-0.6110	-0.6609	-0.0799	*****	*****	*****	*****	*****	*****	*****
0.100	-0.6087	-0.6623	-0.0904	*****	*****	*****	*****	*****	*****	*****
0.150	-0.6360	-0.6740	-0.1051	*****	*****	*****	*****	*****	*****	*****
0.200	-0.6494	-0.6779	-0.1311	*****	*****	*****	*****	*****	*****	-0.5492
0.250	*****	-0.7105	-0.1661	-0.8104	-0.8104	-0.6488	*****	*****	*****	*****
0.300	-0.6733	-0.7555	-0.2311	-0.8409	-0.8409	-0.7236	*****	*****	*****	*****
0.350	*****	-0.8359	-0.3377	-0.8981	-0.8981	-0.7819	*****	*****	*****	*****
0.400	-0.7930	-0.9721	-0.5189	-0.9405	-0.9405	-0.8253	*****	*****	*****	*****
0.450	-0.9944	-1.1660	-0.7572	-0.9789	-0.9789	-0.8124	*****	*****	*****	*****
0.500	-1.3241	-1.3777	-1.0576	-0.9900	-0.9900	-0.7577	*****	*****	*****	*****
0.525	*****	-1.4810	-1.1991	-0.9889	-0.9889	-0.7658	*****	*****	*****	*****
0.550	-1.6239	-1.5743	-1.3146	-0.9732	-0.9732	-0.7527	*****	*****	*****	*****
0.575	*****	-1.6537	-1.4198	-0.9837	-0.9837	-0.7669	*****	*****	*****	*****
0.600	-1.8016	-1.6914	-1.4416	-0.9908	-0.9908	-0.7649	*****	*****	*****	*****
0.625	*****	*****	-1.2718	-0.9806	-0.9806	-0.7645	*****	*****	*****	*****
0.650	-1.7539	-1.4978	-1.1413	-0.9673	-0.9673	-0.7541	*****	*****	*****	*****
0.675	*****	-1.4932	-1.1004	-0.9469	-0.9469	-0.7306	*****	*****	*****	*****
0.700	-1.7376	-1.4916	-1.0770	-0.9321	-0.9321	-0.7174	*****	*****	*****	*****
0.725	*****	-1.4909	*****	-0.9139	-0.9139	-0.7018	*****	*****	*****	*****
0.750	-1.7280	-1.4954	*****	-0.8975	-0.8975	-0.6785	*****	*****	*****	*****
0.775	*****	-1.5230	-0.9903	-0.8827	-0.8827	-0.6588	*****	*****	*****	*****
0.800	-1.5410	-1.5256	-0.9716	-0.8800	-0.8800	*****	*****	*****	*****	*****
0.825	*****	-1.4786	-0.9757	-0.8792	-0.8792	-0.6279	*****	*****	*****	*****
0.850	-1.4353	-1.4382	-0.9550	-0.8749	-0.8749	-0.6070	*****	*****	*****	*****
0.875	*****	-1.4215	-0.9065	-0.8699	-0.8699	-0.5897	*****	*****	*****	*****
0.900	-1.4088	-1.4220	-0.8488	-0.8588	-0.8588	-0.5634	*****	*****	*****	*****
0.925	*****	-1.4211	-0.8105	-0.8393	-0.8393	-0.5518	*****	*****	*****	*****
0.950	-1.3886	-1.4139	-0.7965	-0.8313	-0.8313	-0.5110	*****	*****	*****	*****
0.975	*****	-1.4052	-0.7842	-0.8150	-0.8150	-0.4763	*****	*****	*****	*****
1.000	-1.4103	-1.4124	-0.7069	-0.7986	-0.7986	-0.4457	*****	*****	*****	*****
-0.200	$C_{p,l}$	$C_{p,l}$	$C_{p,l}$	$C_{p,l}$	$C_{p,l}$	$C_{p,l}$	$C_{p,l}$	$C_{p,l}$	$C_{p,l}$	$C_{p,l}$
-0.400	0.5782	0.5163	0.4737	*****	*****	-0.5449	*****	*****	*****	*****
-0.600	0.5850	0.5128	0.4505	0.2433	-0.6056	*****	*****	*****	*****	*****
-0.700	0.5831	0.5138	0.4404	0.2667	-0.5746	*****	*****	*****	*****	*****
-0.800	0.5683	0.5135	0.4422	0.2814	-0.5395	*****	*****	*****	*****	*****
-0.850	0.5186	0.4945	0.4357	0.2918	-0.4557	*****	*****	*****	*****	*****
-0.900	0.4666	0.4579	0.4186	0.2892	-0.4401	*****	*****	*****	*****	*****
-0.950	*****	0.3787	0.3699	0.2713	-0.3878	*****	*****	*****	*****	*****
-0.975	0.1447	0.1829	0.2083	0.1692	-0.1552	*****	*****	*****	*****	*****
-1.000	*****	-0.0874	-0.0117	-0.0076	-0.1325	*****	*****	*****	*****	*****
	-1.4585	-1.4334	-0.7645	-0.7911	-0.4729	*****	*****	*****	*****	*****

Medium Radius L.E.
 Run No. = 6, Point No. = 125
 $C_N = 1.132$, $C_m = -0.1972$
 $\alpha = 24.6^\circ$, $M_\infty = 0.829$
 $R_{mac} = 6.0 \times 10^6$

Leading Edge Pressures



x/c_R	starb'd C_p	port C_p
0.10	-1.4722	*****
0.20	-1.4103	-1.4585
0.30	-1.4649	*****
0.40	-1.4124	-1.4334
0.50	-1.3212	*****
0.60	-0.7069	-0.7645
0.70	-0.7743	*****
0.80	-0.7986	-0.7911
0.90	*****	*****
0.95	-0.4457	-0.4729

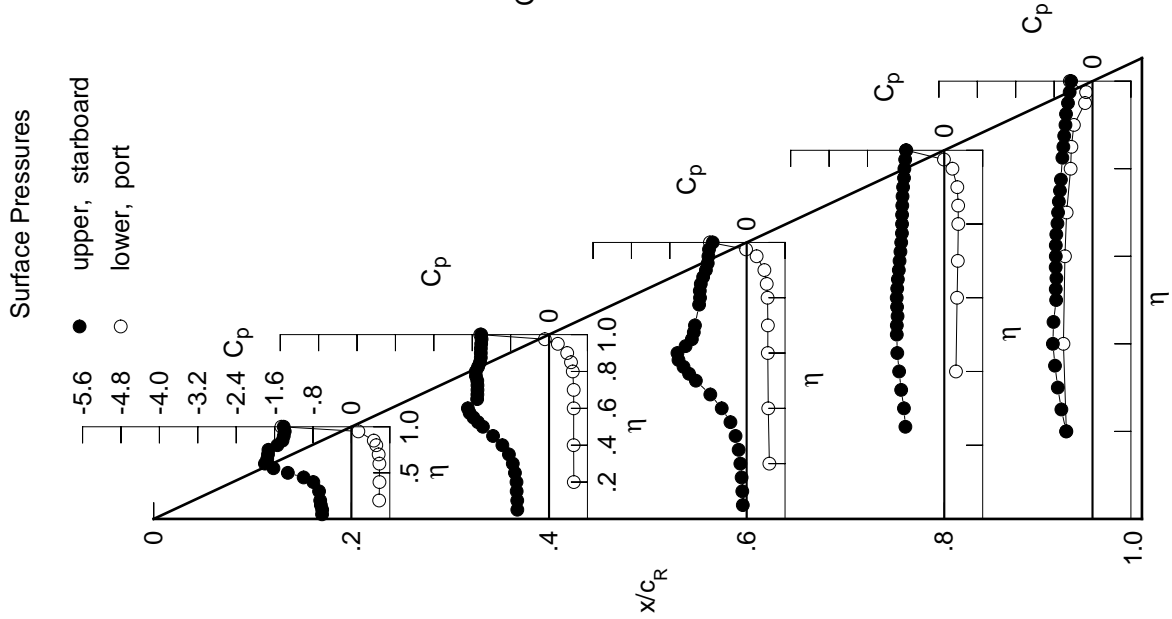

Table F2. Concluded.

η	x/c_R .2	x/c_R .4	x/c_R .6	x/c_R .8	x/c_R .95
	$C_{p,u}$	$C_{p,u}$	$C_{p,u}$	$C_{p,u}$	$C_{p,u}$
0.050	-0.7061	-0.7321	-0.0941	*****	*****
0.100	-0.7078	-0.7338	-0.0983	*****	*****
0.150	-0.7315	-0.7466	-0.1120	*****	*****
0.200	-0.7310	-0.7629	-0.1366	*****	-0.6801
0.250	*****	-0.8080	-0.1819	-1.0544	-0.7980
0.300	-0.7956	-0.8762	-0.2616	-1.0487	-0.8666
0.350	*****	-0.9860	-0.3915	-1.0401	-0.8571
0.400	-1.0446	-1.1445	-0.5885	-0.9923	-0.8096
0.450	-1.2988	-1.3343	-0.8250	-0.9487	-0.7687
0.500	-1.5674	-1.5140	-1.0932	-0.9339	-0.7523
0.525	*****	-1.5937	-1.2136	-0.9428	-0.7730
0.550	-1.7564	-1.6666	-1.3117	-0.9543	-0.7747
0.575	*****	-1.7235	-1.3779	-0.9832	-0.7893
0.600	-1.7528	-1.7220	-1.3219	-1.0002	-0.7892
0.625	*****	*****	-1.1365	-0.9946	-0.7915
0.650	-1.7035	-1.5677	-1.0386	-0.9879	-0.7849
0.675	*****	-1.5646	-1.0114	-0.9849	-0.7689
0.700	-1.7128	-1.5574	-0.9930	-0.9826	-0.7591
0.725	*****	-1.5531	*****	-0.9716	-0.7453
0.750	-1.7467	-1.5568	*****	-0.9516	-0.7241
0.775	*****	-1.5767	-0.9223	-0.9402	-0.7071
0.800	-1.6097	-1.5860	-0.9061	-0.9360	*****
0.825	*****	-1.5456	-0.8979	-0.9322	-0.6727
0.850	-1.4768	-1.5049	-0.8902	-0.9220	-0.6520
0.875	*****	-1.4843	-0.8758	-0.9100	-0.6320
0.900	-1.4631	-1.4793	-0.8553	-0.8980	-0.6108
0.925	*****	-1.4823	-0.8334	-0.8762	-0.6002
0.950	-1.4568	-1.4766	-0.8258	-0.8651	-0.5610
0.975	*****	-1.4706	-0.8220	-0.8354	-0.5248
1.000	-1.4927	-1.4845	-0.7689	-0.8082	-0.4836
	$C_{p,l}$	$C_{p,l}$	$C_{p,l}$	$C_{p,l}$	$C_{p,l}$
-0.200	0.6332	0.5624	0.5114	*****	-0.5169
-0.400	0.6388	0.5627	0.4923	0.2767	-0.5787
-0.600	0.6313	0.5586	0.4782	0.2983	-0.5472
-0.700	0.6087	0.5541	0.4771	0.3048	-0.5172
-0.800	0.5460	0.5236	0.4615	0.3151	-0.4254
-0.850	0.4837	0.4812	0.4390	0.3131	-0.4143
-0.900	*****	0.3857	0.3777	0.2845	-0.3642
-0.950	0.1264	0.1698	0.1935	0.1612	-0.1482
-0.975	*****	-0.1196	-0.0464	-0.0332	-0.1494
-1.000	-1.5697	-1.4992	-0.8367	-0.7776	-0.5105

Medium Radius L.E.
 Run No. = 6, Point No. = 126
 $C_N = 1.215$, $C_m = -0.2091$
 $\alpha = 26.6^\circ$, $M_\infty = 0.829$
 $R_{mac} = 6.0 \times 10^6$

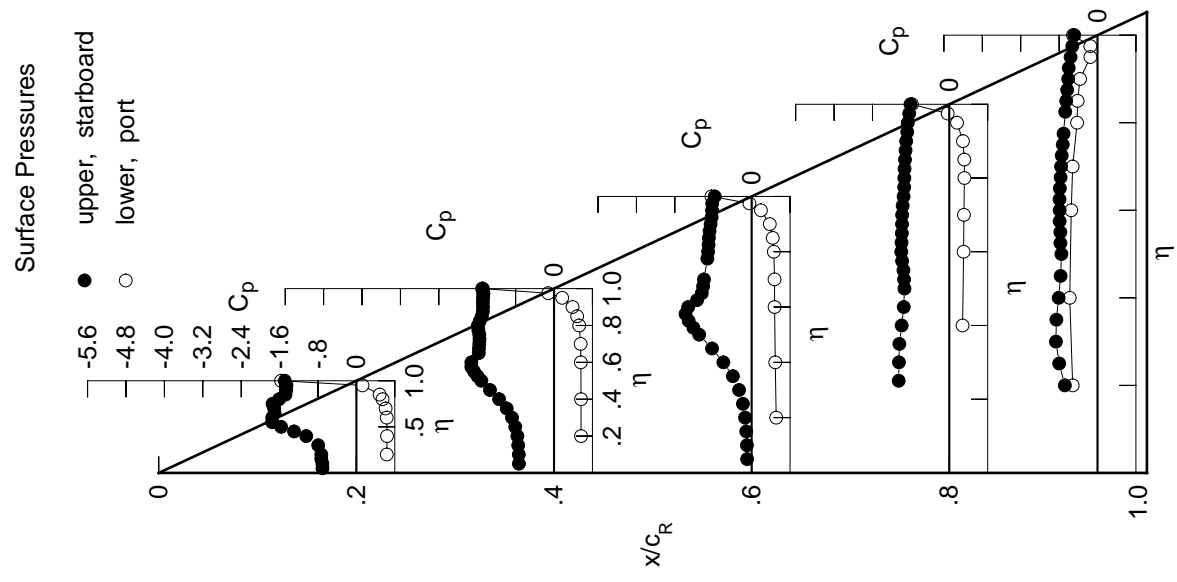
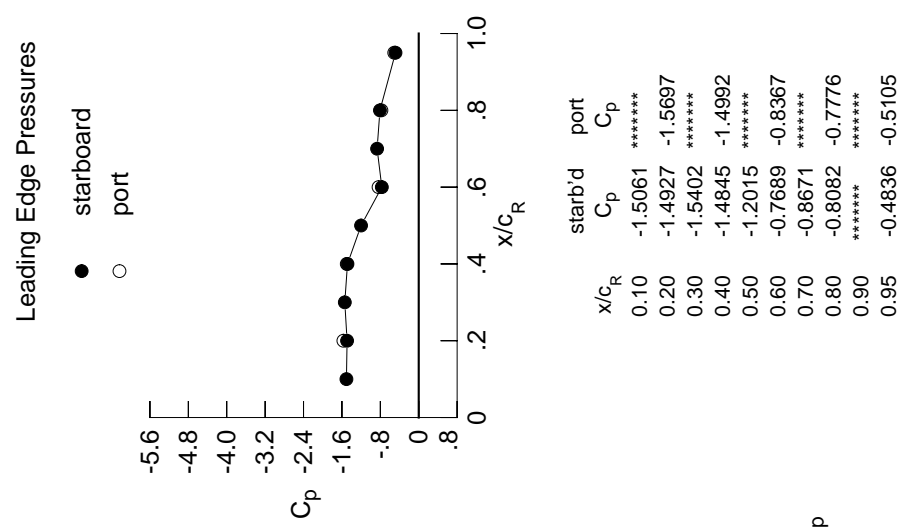

Table F3. Tabulations and Plots of Surface Pressure Coefficients.

η	$x/c_R = .2$		$x/c_R = .4$		$x/c_R = .6$		$x/c_R = .8$		$x/c_R = .95$	
	$C_{p,u}$	$C_{p,u}$	$C_{p,u}$	$C_{p,u}$	$C_{p,u}$	$C_{p,u}$	$C_{p,u}$	$C_{p,u}$	$C_{p,u}$	$C_{p,u}$
0.050	-0.0089	0.0078	0.1372	*****	*****	*****	*****	*****	*****	*****
0.100	-0.0051	0.0012	0.1264	*****	*****	*****	*****	*****	*****	*****
0.150	-0.0111	0.0038	0.1129	*****	*****	*****	*****	*****	*****	*****
0.200	-0.0158	0.0078	0.0986	*****	*****	*****	*****	*****	*****	*****
0.250	*****	0.0059	0.0871	-0.1311	-0.1311	-0.1311	-0.1311	-0.1311	-0.1311	-0.1311
0.300	-0.0219	0.0055	0.0773	-0.1150	-0.1150	-0.1150	-0.1150	-0.1150	-0.1150	-0.1150
0.350	*****	0.0043	0.0660	-0.1030	-0.1030	-0.1030	-0.1030	-0.1030	-0.1030	-0.1030
0.400	-0.0352	0.0042	0.0545	-0.0936	-0.0936	-0.0936	-0.0936	-0.0936	-0.0936	-0.0936
0.450	-0.0389	-0.0004	0.0546	-0.0880	-0.0880	-0.0880	-0.0880	-0.0880	-0.0880	-0.0880
0.500	-0.0476	0.0004	0.0422	-0.0791	-0.0791	-0.0791	-0.0791	-0.0791	-0.0791	-0.0791
0.525	*****	-0.0007	0.0419	-0.0805	-0.0805	-0.0805	-0.0805	-0.0805	-0.0805	-0.0805
0.550	-0.0522	-0.0060	0.0368	-0.0770	-0.0770	-0.0770	-0.0770	-0.0770	-0.0770	-0.0770
0.575	*****	-0.0048	0.0394	-0.0766	-0.0766	-0.0766	-0.0766	-0.0766	-0.0766	-0.0766
0.600	-0.0546	-0.0090	0.0295	-0.0742	-0.0742	-0.0742	-0.0742	-0.0742	-0.0742	-0.0742
0.625	*****	*****	0.0303	-0.0753	-0.0753	-0.0753	-0.0753	-0.0753	-0.0753	-0.0753
0.650	-0.0557	-0.0284	0.0264	-0.0731	-0.0731	-0.0731	-0.0731	-0.0731	-0.0731	-0.0731
0.675	*****	-0.0347	0.0212	-0.0693	-0.0693	-0.0693	-0.0693	-0.0693	-0.0693	-0.0693
0.700	-0.0509	-0.0403	0.0195	-0.0693	-0.0693	-0.0693	-0.0693	-0.0693	-0.0693	-0.0693
0.725	*****	-0.0467	*****	-0.0704	-0.0704	-0.0704	-0.0704	-0.0704	-0.0704	-0.0704
0.750	-0.0405	-0.0504	*****	-0.0734	-0.0734	-0.0734	-0.0734	-0.0734	-0.0734	-0.0734
0.775	*****	-0.0582	-0.0165	-0.0696	-0.0696	-0.0696	-0.0696	-0.0696	-0.0696	-0.0696
0.800	-0.0262	-0.0588	-0.0265	-0.0797	-0.0797	-0.0797	-0.0797	-0.0797	-0.0797	-0.0797
0.825	*****	-0.0601	-0.0358	-0.0870	-0.0870	-0.0870	-0.0870	-0.0870	-0.0870	-0.0870
0.850	-0.0021	-0.0565	-0.0482	-0.0972	-0.0972	-0.0972	-0.0972	-0.0972	-0.0972	-0.0972
0.875	*****	-0.0448	-0.0504	-0.1084	-0.1084	-0.1084	-0.1084	-0.1084	-0.1084	-0.1084
0.900	0.0300	-0.0301	-0.0475	-0.1166	-0.1166	-0.1166	-0.1166	-0.1166	-0.1166	-0.1166
0.925	*****	-0.0094	-0.0352	-0.1119	-0.1119	-0.1119	-0.1119	-0.1119	-0.1119	-0.1119
0.950	0.0790	0.0213	-0.0044	-0.0866	-0.0866	-0.0866	-0.0866	-0.0866	-0.0866	-0.0866
0.975	*****	0.0785	0.0533	-0.0208	-0.2094	-0.2094	-0.2094	-0.2094	-0.2094	-0.2094
1.000	0.1974	0.1884	0.1489	0.1328	0.1328	0.1328	0.1328	0.1328	0.1328	0.1328
$C_{p,l}$	$C_{p,l}$	$C_{p,l}$	$C_{p,l}$	$C_{p,l}$	$C_{p,l}$	$C_{p,l}$	$C_{p,l}$	$C_{p,l}$	$C_{p,l}$	$C_{p,l}$
-0.200	-0.0328	-0.0085	0.0819	*****	*****	*****	*****	*****	*****	*****
-0.400	-0.0615	-0.0076	0.0395	-0.1031	-0.1031	-0.1031	-0.1031	-0.1031	-0.1031	-0.1031
-0.600	-0.0864	-0.0203	0.0126	-0.0879	-0.0879	-0.0879	-0.0879	-0.0879	-0.0879	-0.0879
-0.700	-0.0872	-0.0707	-0.0054	-0.0874	-0.0874	-0.0874	-0.0874	-0.0874	-0.0874	-0.0874
-0.800	-0.0731	-0.0994	-0.0687	-0.1022	-0.1022	-0.1022	-0.1022	-0.1022	-0.1022	-0.1022
-0.850	-0.0538	-0.1032	-0.0905	-0.1369	-0.1369	-0.1369	-0.1369	-0.1369	-0.1369	-0.1369
-0.900	*****	-0.0891	-0.1055	-0.1704	-0.1704	-0.1704	-0.1704	-0.1704	-0.1704	-0.1704
-0.950	0.0280	-0.0418	-0.0758	-0.1578	-0.1578	-0.1578	-0.1578	-0.1578	-0.1578	-0.1578
-0.975	*****	0.0118	-0.0255	-0.1049	-0.2634	-0.2634	-0.2634	-0.2634	-0.2634	-0.2634
-1.000	0.1921	0.1787	0.1572	0.1262	0.1262	0.1262	0.1262	0.1262	0.1262	0.1262

Medium Radius L.E.

Run No. = 8, Point No. = 149

$C_N = -0.017$, $C_m = -0.0036$

$\alpha = -0.4^\circ$, $M_\infty = 0.870$

$R_{mac} = 6.0 \times 10^6$

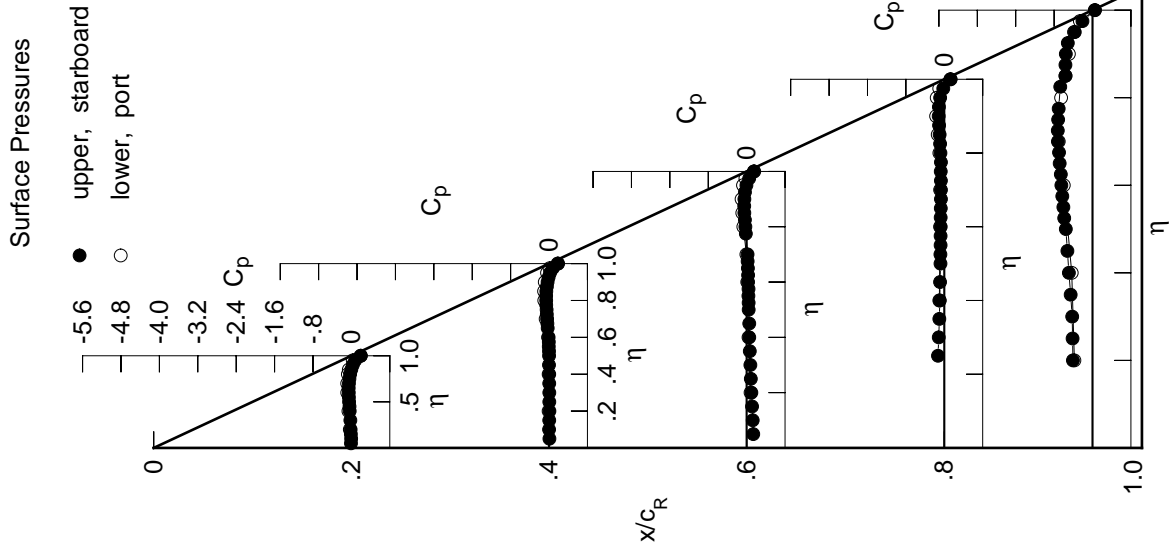

Leading Edge Pressures

- starboard
- port

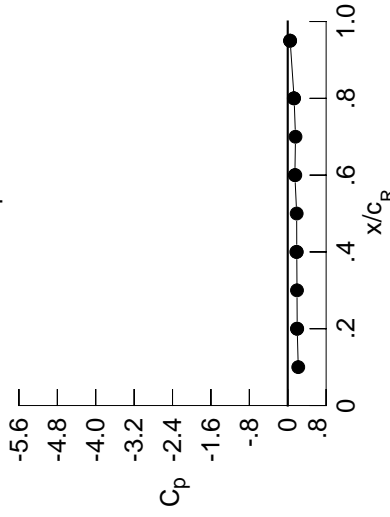

x/c_R	starb'd C_p	port C_p
0.10	0.2192	*****
0.20	0.1974	0.1921
0.30	0.1930	*****
0.40	0.1884	0.1787
0.50	0.1861	*****
0.60	0.1489	0.1572
0.70	0.1618	*****
0.80	0.1328	0.1262
0.90	*****	*****
0.95	0.0506	0.0483

Table F3. Continued.

η	$x/c_R = .2$		$x/c_R = .4$		$x/c_R = .6$		$x/c_R = .8$		$x/c_R = .95$	
	$C_{p,u}$	$C_{p,u}$	$C_{p,u}$	$C_{p,u}$	$C_{p,u}$	$C_{p,u}$	$C_{p,u}$	$C_{p,u}$	$C_{p,u}$	$C_{p,u}$
0.050	-0.0148	0.0008	0.1325	0.1325	0.0942	0.0942	0.0942	0.0942	0.0942	0.0942
0.100	-0.0151	-0.0036	0.1226	0.1226	0.0826	0.0826	0.0826	0.0826	0.0826	0.0826
0.150	-0.0211	-0.0041	0.1077	0.1077	0.0614	0.0614	0.0614	0.0614	0.0614	0.0614
0.200	-0.0208	-0.0003	0.0942	0.0942	0.0497	0.0497	0.0497	0.0497	0.0497	0.0497
0.250	*****	-0.0030	0.0826	0.0826	0.0374	0.0374	0.0374	0.0374	0.0374	0.0374
0.300	-0.0289	-0.0006	0.0708	0.0708	0.1204	0.1204	0.1204	0.1204	0.1204	0.1204
0.350	*****	-0.0058	0.0614	0.0614	-0.1084	-0.1084	-0.1084	-0.1084	-0.1084	-0.1084
0.400	-0.0422	-0.0027	0.0497	0.0497	0.0992	0.0992	0.0992	0.0992	0.0992	0.0992
0.450	-0.0501	-0.0100	0.0474	0.0474	0.0931	0.0931	0.0931	0.0931	0.0931	0.0931
0.500	-0.0595	-0.0050	0.0341	0.0341	-0.0870	-0.0870	-0.0870	-0.0870	-0.0870	-0.0870
0.525	*****	-0.0092	0.0347	0.0347	-0.0879	-0.0879	-0.0879	-0.0879	-0.0879	-0.0879
0.550	-0.0636	-0.0125	0.0314	0.0314	-0.0803	-0.0803	-0.0803	-0.0803	-0.0803	-0.0803
0.575	*****	-0.0132	0.0310	0.0310	-0.0812	-0.0812	-0.0812	-0.0812	-0.0812	-0.0812
0.600	-0.0667	-0.0184	0.0230	0.0230	-0.0779	-0.0779	-0.0779	-0.0779	-0.0779	-0.0779
0.625	*****	*****	0.0216	0.0216	-0.0774	-0.0774	-0.0774	-0.0774	-0.0774	-0.0774
0.650	-0.0683	-0.0475	0.0204	0.0204	-0.0776	-0.0776	-0.0776	-0.0776	-0.0776	-0.0776
0.675	*****	-0.0505	0.0142	0.0142	-0.0781	-0.0781	-0.0781	-0.0781	-0.0781	-0.0781
0.700	-0.0642	-0.0558	0.0100	0.0100	-0.0765	-0.0765	-0.0765	-0.0765	-0.0765	-0.0765
0.725	*****	-0.0593	*****	*****	-0.0762	-0.0762	-0.0762	-0.0762	-0.0762	-0.0762
0.750	-0.0554	-0.0651	*****	*****	-0.0794	-0.0794	-0.0794	-0.0794	-0.0794	-0.0794
0.775	*****	-0.0722	-0.0347	-0.0347	-0.0759	-0.0759	-0.0759	-0.0759	-0.0759	-0.0759
0.800	-0.0428	-0.0776	-0.0418	-0.0418	-0.0856	-0.0856	-0.0856	-0.0856	-0.0856	-0.0856
0.825	*****	-0.0774	-0.0514	-0.0514	-0.1012	-0.1012	-0.1012	-0.1012	-0.1012	-0.1012
0.850	-0.0197	-0.0764	-0.0647	-0.0647	-0.1139	-0.1139	-0.1139	-0.1139	-0.1139	-0.1139
0.875	*****	-0.0676	-0.0703	-0.0703	-0.1250	-0.1250	-0.1250	-0.1250	-0.1250	-0.1250
0.900	0.0118	-0.0529	-0.0683	-0.0683	-0.1359	-0.1359	-0.1359	-0.1359	-0.1359	-0.1359
0.925	*****	-0.0356	-0.0588	-0.0588	-0.1333	-0.1333	-0.1333	-0.1333	-0.1333	-0.1333
0.950	0.0595	-0.0008	-0.0309	-0.1114	-0.3833	-0.3833	-0.3833	-0.3833	-0.3833	-0.3833
0.975	*****	0.0540	0.0232	-0.0509	-0.2298	-0.2298	-0.2298	-0.2298	-0.2298	-0.2298
1.000	0.1988	0.1934	0.1603	0.1603	0.1441	0.1441	0.1441	0.1441	0.1441	0.1441
-0.200	$C_{p,l}$	$C_{p,l}$	$C_{p,l}$	$C_{p,l}$	$C_{p,l}$	$C_{p,l}$	$C_{p,l}$	$C_{p,l}$	$C_{p,l}$	$C_{p,l}$
-0.400	-0.0224	-0.0009	0.0921	0.0921	0.0921	0.0921	0.0921	0.0921	0.0921	0.0921
-0.600	-0.0485	-0.0003	0.0468	0.0468	-0.0963	-0.0963	-0.0963	-0.0963	-0.0963	-0.0963
-0.700	-0.0741	-0.0142	0.0193	0.0193	-0.0786	-0.0786	-0.0786	-0.0786	-0.0786	-0.0786
-0.800	-0.0715	-0.0536	0.0023	0.0023	-0.0784	-0.0784	-0.0784	-0.0784	-0.0784	-0.0784
-0.850	-0.0545	-0.0822	-0.0494	-0.0494	-0.0830	-0.0830	-0.0830	-0.0830	-0.0830	-0.0830
-0.900	-0.0333	-0.0810	-0.0721	-0.0721	-0.1204	-0.1204	-0.1204	-0.1204	-0.1204	-0.1204
-0.950	*****	-0.0654	-0.0818	-0.0818	-0.1485	-0.1485	-0.1485	-0.1485	-0.1485	-0.1485
-0.975	0.0501	-0.0130	-0.0444	-0.0444	-0.1274	-0.1274	-0.1274	-0.1274	-0.1274	-0.1274
-1.000	0.1978	0.1872	0.1709	0.1709	0.1437	0.1437	0.1437	0.1437	0.1437	0.1437

Medium Radius L.E.
 Run No. = 8, Point No. = 150
 $C_N = -0.008$, $C_m = 0.0008$
 $\alpha = 0.0^\circ$, $M_\infty = 0.870$
 $R_{mac} = 6.0 \times 10^6$

Leading Edge Pressures

● starboard
 ○ port

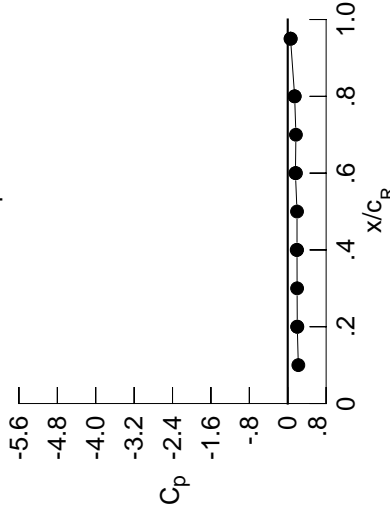

x/c_R	starb'd C_p	port C_p
0.10	0.2205	*****
0.20	0.1988	0.1978
0.30	0.1950	*****
0.40	0.1934	0.1872
0.50	0.1935	*****
0.60	0.1603	0.1709
0.70	0.1705	*****
0.80	0.1441	0.1437
0.90	*****	*****
0.95	0.0583	0.0624

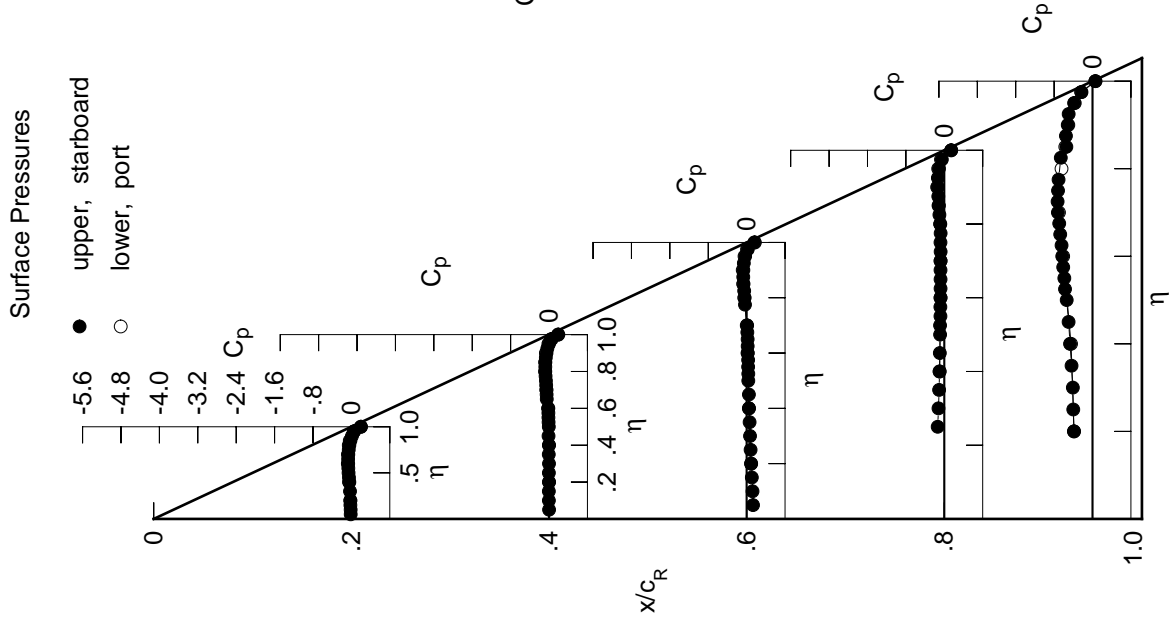

Table F3. Continued.

η	x/c_R .2	x/c_R .4	x/c_R .6	x/c_R .8	x/c_R .95
	$C_{p,u}$	$C_{p,u}$	$C_{p,u}$	$C_{p,u}$	$C_{p,u}$
0.050	-0.0339	-0.0169	0.1185	*****	*****
0.100	-0.0350	-0.0201	0.1077	*****	*****
0.150	-0.0391	-0.0212	0.0964	*****	*****
0.200	-0.0414	-0.0165	0.0832	*****	-0.3639
0.250	*****	-0.0189	0.0698	-0.1510	-0.3628
0.300	-0.0493	-0.0200	0.0574	-0.1343	-0.3762
0.350	*****	-0.0220	0.0466	-0.1218	-0.4034
0.400	-0.0702	-0.0228	0.0385	-0.1127	-0.4272
0.450	-0.0775	-0.0275	0.0322	-0.1071	-0.4568
0.500	-0.0844	-0.0279	0.0196	-0.1004	-0.4884
0.525	*****	-0.0273	0.0194	-0.1021	-0.5065
0.550	-0.0899	-0.0345	0.0145	-0.0955	-0.5442
0.575	*****	-0.0294	0.0147	-0.0965	-0.5631
0.600	-0.0961	-0.0280	0.0053	-0.0931	-0.5732
0.625	*****	*****	0.0067	-0.0961	-0.5697
0.650	-0.0995	-0.0828	-0.0002	-0.0966	-0.6172
0.675	*****	-0.0853	-0.0044	-0.0942	-0.6774
0.700	-0.0984	-0.0910	-0.0078	-0.0961	-0.7259
0.725	*****	-0.0924	*****	-0.0957	-0.7354
0.750	-0.0927	-0.0983	*****	-0.1008	-0.7291
0.775	*****	-0.1093	-0.0749	-0.0982	-0.7153
0.800	-0.0823	-0.1142	-0.0912	-0.0989	*****
0.825	*****	-0.1204	-0.0941	-0.1462	-0.6336
0.850	-0.0624	-0.1212	-0.1055	-0.1508	-0.5211
0.875	*****	-0.1185	-0.1180	-0.1651	-0.5210
0.900	-0.0336	-0.1069	-0.1196	-0.1837	-0.4926
0.925	*****	-0.0926	-0.1173	-0.1911	-0.4807
0.950	-0.0099	-0.0624	-0.0980	-0.1770	-0.4169
0.975	*****	-0.0157	-0.0506	-0.1262	-0.2880
1.000	0.1853	0.1709	0.1392	0.1149	0.0343
	$C_{p,l}$	$C_{p,l}$	$C_{p,l}$	$C_{p,l}$	$C_{p,l}$
-0.200	-0.0004	0.0170	0.1047	*****	-0.4128
-0.400	-0.0265	0.0174	0.0627	-0.0838	-0.4800
-0.600	-0.0443	0.0040	0.0386	-0.0635	-0.6537
-0.700	-0.0381	-0.0255	0.0216	-0.0582	-0.6996
-0.800	-0.0160	-0.0437	-0.0162	-0.0604	-0.6914
-0.850	0.0076	-0.0371	-0.0344	-0.0871	-0.6539
-0.900	*****	-0.0144	-0.0326	-0.1034	-0.5467
-0.950	0.0951	0.0426	0.0155	-0.0665	-0.3382
-0.975	*****	0.0988	0.0721	-0.0016	-0.1884
-1.000	0.1922	0.1783	0.1546	0.1313	0.0531

Medium Radius L.E.
 Run No. = 8, Point No. = 151
 $C_N = 0.039$, $C_m = -0.0099$
 $\alpha = 1.1^\circ$, $M_\infty = 0.870$
 $R_{mac} = 6.0 \times 10^6$

Leading Edge Pressures

- starboard
- port

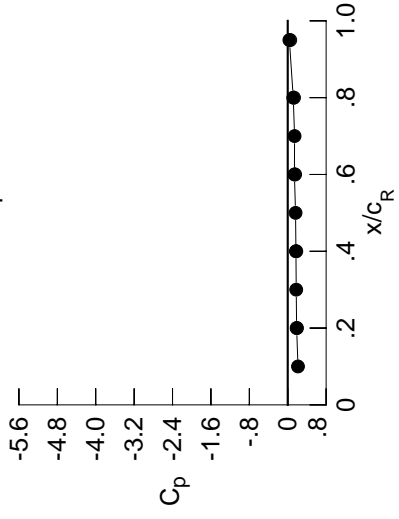

x/c_R	starb'd C_p	port C_p
0.10	0.2138	*****
0.20	0.1853	0.1922
0.30	0.1770	*****
0.40	0.1709	0.1783
0.50	0.1629	*****
0.60	0.1392	0.1546
0.70	0.1426	*****
0.80	0.1149	0.1313
0.90	*****	*****
0.95	0.0343	0.0531

Surface Pressures

- upper, starboard
- lower, port

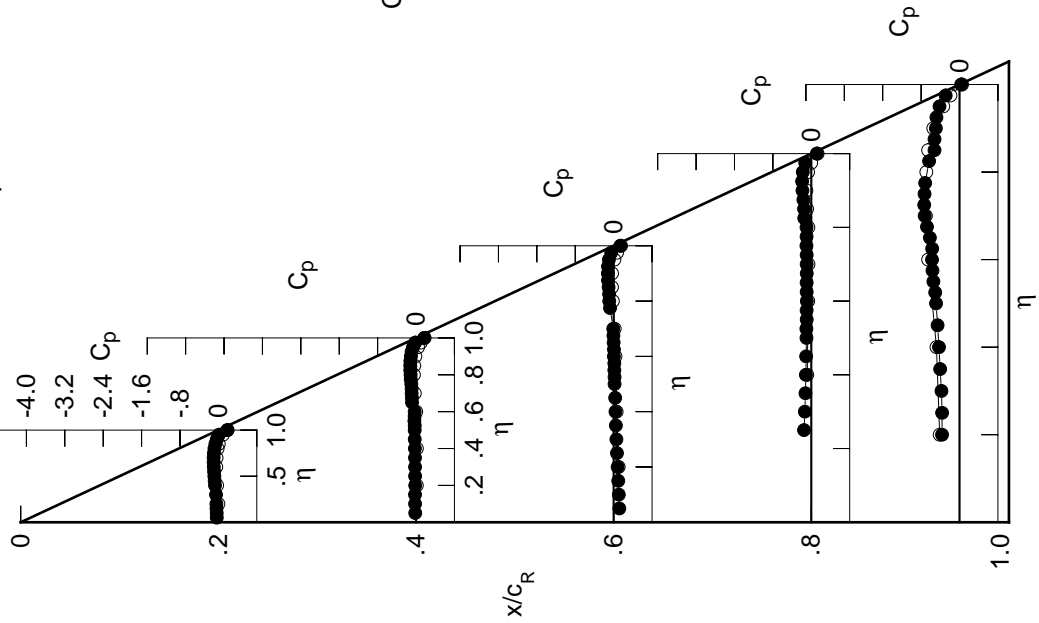

Table F3. Continued.

η	$x/c_R = .2$		$x/c_R = .4$		$x/c_R = .6$		$x/c_R = .8$		$x/c_R = .95$	
	$C_{p,u}$	$C_{p,u}$	$C_{p,u}$	$C_{p,u}$	$C_{p,u}$	$C_{p,u}$	$C_{p,u}$	$C_{p,u}$	$C_{p,u}$	$C_{p,u}$
0.050	-0.0548	-0.0360	0.1063	*****	*****	*****	*****	*****	*****	*****
0.100	-0.0532	-0.0381	0.0950	*****	*****	*****	*****	*****	*****	*****
0.150	-0.0575	-0.0388	0.0831	*****	*****	*****	*****	*****	*****	*****
0.200	-0.0603	-0.0353	0.0673	*****	*****	*****	*****	*****	*****	-0.3461
0.250	*****	-0.0370	0.0557	0.1652	-0.1652	-0.3536	*****	*****	*****	-0.3536
0.300	-0.0696	-0.0393	0.0423	-0.1478	-0.1478	-0.3541	*****	*****	*****	-0.3541
0.350	*****	-0.0435	0.0332	-0.1346	-0.1346	-0.3756	*****	*****	*****	-0.3756
0.400	-0.0882	-0.0444	0.0210	-0.1270	-0.1270	-0.4018	*****	*****	*****	-0.4018
0.450	-0.0968	-0.0488	0.0166	-0.1216	-0.1216	-0.4260	*****	*****	*****	-0.4260
0.500	-0.1067	-0.0524	-0.0004	-0.1172	-0.1172	-0.4425	*****	*****	*****	-0.4425
0.525	*****	-0.0543	0.0023	-0.1190	-0.1190	-0.4567	*****	*****	*****	-0.4567
0.550	-0.1134	-0.0639	-0.0070	-0.1140	-0.1140	-0.4581	*****	*****	*****	-0.4581
0.575	*****	-0.0640	-0.0061	-0.1133	-0.1133	-0.4721	*****	*****	*****	-0.4721
0.600	-0.1231	-0.0682	-0.0181	-0.1134	-0.1134	-0.4865	*****	*****	*****	-0.4865
0.625	*****	*****	-0.0160	-0.1154	-0.1154	-0.5057	*****	*****	*****	-0.5057
0.650	-0.1298	-0.0802	0.0243	-0.1188	-0.1188	-0.5366	*****	*****	*****	-0.5366
0.675	*****	-0.0942	-0.0302	-0.1161	-0.1161	-0.5625	*****	*****	*****	-0.5625
0.700	-0.1339	-0.1091	-0.0401	-0.1202	-0.1202	-0.5805	*****	*****	*****	-0.5805
0.725	*****	-0.1204	*****	-0.1208	-0.1208	-0.5529	*****	*****	*****	-0.5529
0.750	-0.1293	-0.1290	*****	-0.1299	-0.1299	-0.4592	*****	*****	*****	-0.4592
0.775	*****	-0.1456	-0.0788	-0.1318	-0.1318	-0.3426	*****	*****	*****	-0.3426
0.800	-0.1229	-0.1545	-0.0995	-0.1460	-0.1460	*****	*****	*****	*****	*****
0.825	*****	-0.1647	-0.1233	-0.1509	-0.1509	-0.3131	*****	*****	*****	-0.3131
0.850	-0.1060	-0.1662	-0.1454	-0.1798	-0.1798	-0.3759	*****	*****	*****	-0.3759
0.875	*****	-0.1690	-0.1657	-0.2039	-0.2039	-0.6338	*****	*****	*****	-0.6338
0.900	-0.0833	-0.1627	-0.1750	-0.2326	-0.2326	-0.8378	*****	*****	*****	-0.8378
0.925	*****	-0.1560	-0.1812	-0.2497	-0.2497	-0.9887	*****	*****	*****	-0.9887
0.950	-0.0448	-0.1307	-0.1726	-0.2486	-0.2486	-0.4777	*****	*****	*****	-0.4777
0.975	*****	-0.0963	-0.1383	-0.2159	-0.2159	-0.3646	*****	*****	*****	-0.3646
1.000	0.1466	0.1049	0.0682	0.0161	-0.0480	*****	*****	*****	*****	-0.0480
-0.200	$C_{p,l}$	$C_{p,l}$	$C_{p,l}$	$C_{p,l}$	$C_{p,l}$	$C_{p,l}$	$C_{p,l}$	$C_{p,l}$	$C_{p,l}$	$C_{p,l}$
-0.400	0.0170	0.0331	0.1160	*****	*****	-0.4501	*****	*****	*****	-0.4501
-0.600	-0.0048	0.0374	0.0770	-0.0698	-0.5191	*****	*****	*****	*****	-0.5191
-0.700	-0.0159	0.0281	0.0541	-0.0499	-0.6749	*****	*****	*****	*****	-0.6749
-0.800	-0.0063	0.0052	0.0417	-0.0426	-0.7055	*****	*****	*****	*****	-0.7055
-0.850	0.0203	-0.0085	0.0194	-0.0398	-0.6788	*****	*****	*****	*****	-0.6788
-0.900	0.0451	0.0023	0.0033	-0.0501	-0.6999	*****	*****	*****	*****	-0.6999
-0.950	0.1333	0.0900	0.0666	-0.0142	-0.3130	*****	*****	*****	*****	-0.3130
-0.975	*****	0.1429	0.1223	0.0510	-0.1477	*****	*****	*****	*****	-0.1477
-1.000	0.1580	0.1186	0.0708	0.0476	-0.0083	*****	*****	*****	*****	-0.0083

Medium Radius L.E.
 Run No. = 8, Point No. = 152
 $C_N = 0.079$, $C_m = -0.0167$
 $\alpha = 2.1^\circ$, $M_\infty = 0.870$
 $R_{mac} = 6.0 \times 10^6$

Leading Edge Pressures

● starboard
 ○ port

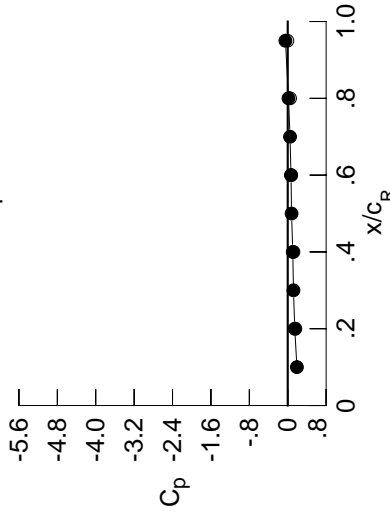

x/c_R	starb'd C_p	port C_p
0.10	0.1914	*****
0.20	0.1466	0.1580
0.30	0.1193	*****
0.40	0.1049	0.1186
0.50	0.0797	*****
0.60	0.0682	0.0708
0.70	0.0478	*****
0.80	0.0161	0.0476
0.90	*****	*****
0.95	-0.0480	-0.0083

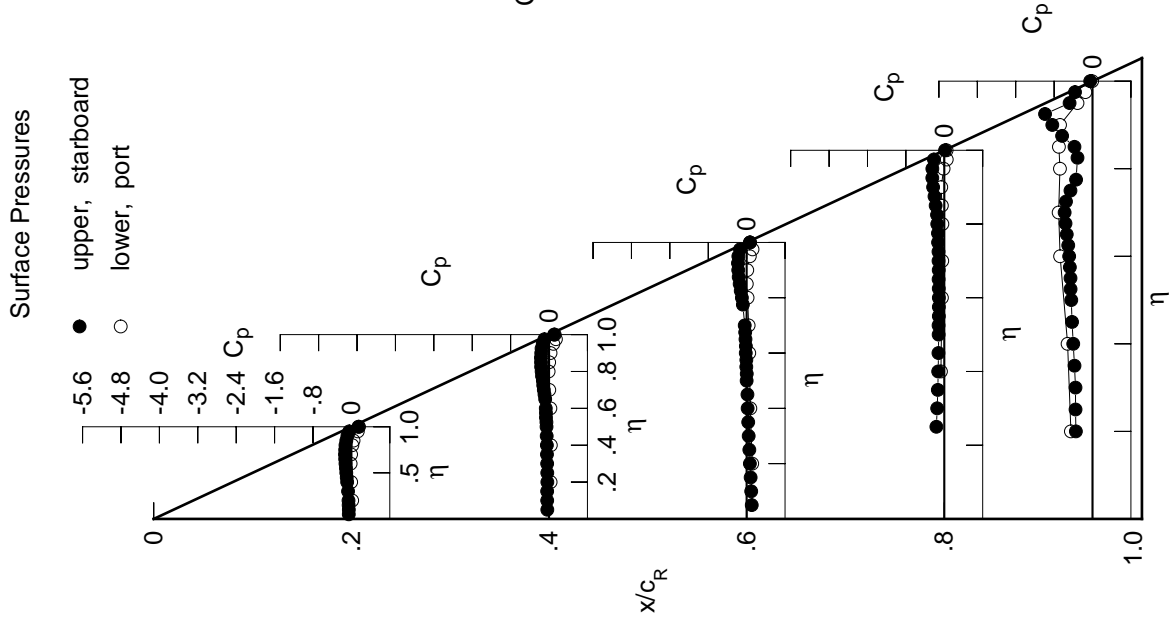

Table F3. Continued.

η	$x/c_R = .2$		$x/c_R = .4$		$x/c_R = .6$		$x/c_R = .8$		$x/c_R = .95$	
	$C_{p,u}$	$C_{p,u}$	$C_{p,u}$	$C_{p,u}$	$C_{p,u}$	$C_{p,u}$	$C_{p,u}$	$C_{p,u}$	$C_{p,u}$	$C_{p,u}$
0.050	-0.0739	-0.0515	0.0935	*****	*****	*****	*****	*****	*****	*****
0.100	-0.0725	-0.0546	0.0827	*****	*****	*****	*****	*****	*****	*****
0.150	-0.0755	-0.0579	0.0684	*****	*****	*****	*****	*****	*****	*****
0.200	-0.0799	-0.0525	0.0551	*****	*****	*****	*****	*****	*****	*****
0.250	*****	-0.0552	0.0420	-0.1772	-0.3320	*****	*****	*****	*****	*****
0.300	-0.0892	-0.0573	0.0302	-0.1599	-0.3211	*****	*****	*****	*****	*****
0.350	*****	-0.0613	0.0179	-0.1488	-0.3359	*****	*****	*****	*****	*****
0.400	-0.1104	-0.0647	0.0048	-0.1409	-0.3578	*****	*****	*****	*****	*****
0.450	-0.1211	-0.0696	-0.0003	-0.1367	-0.3815	*****	*****	*****	*****	*****
0.500	-0.1314	-0.0742	-0.0161	-0.1315	-0.3959	*****	*****	*****	*****	*****
0.525	*****	-0.0771	-0.0168	-0.1359	-0.4062	*****	*****	*****	*****	*****
0.550	-0.1396	-0.0863	-0.0223	-0.1304	-0.4089	*****	*****	*****	*****	*****
0.575	*****	-0.0877	-0.0253	-0.1306	-0.4191	*****	*****	*****	*****	*****
0.600	-0.1516	-0.0926	-0.0350	-0.1307	-0.4319	*****	*****	*****	*****	*****
0.625	*****	*****	-0.0361	-0.1335	-0.4474	*****	*****	*****	*****	*****
0.650	-0.1597	-0.1103	-0.0473	-0.1352	-0.4744	*****	*****	*****	*****	*****
0.675	*****	-0.1220	-0.0554	-0.1369	-0.4837	*****	*****	*****	*****	*****
0.700	-0.1661	-0.1398	-0.0631	-0.1387	-0.4812	*****	*****	*****	*****	*****
0.725	*****	-0.1508	*****	-0.1440	-0.4370	*****	*****	*****	*****	*****
0.750	-0.1648	-0.1652	*****	-0.1531	-0.3606	*****	*****	*****	*****	*****
0.775	*****	-0.1806	-0.1106	-0.1585	-0.2666	*****	*****	*****	*****	*****
0.800	-0.1613	-0.1974	-0.1323	-0.1734	*****	*****	*****	*****	*****	*****
0.825	*****	-0.2079	-0.1597	-0.1851	-0.2653	*****	*****	*****	*****	*****
0.850	-0.1489	-0.2176	-0.1898	-0.2151	-0.3027	*****	*****	*****	*****	*****
0.875	*****	-0.2219	-0.2146	-0.2498	-0.4905	*****	*****	*****	*****	*****
0.900	-0.1309	-0.2242	-0.2383	-0.2883	-0.8160	*****	*****	*****	*****	*****
0.925	*****	-0.2246	-0.2483	-0.3156	-0.9552	*****	*****	*****	*****	*****
0.950	-0.1053	-0.2073	-0.2566	-0.3279	-0.5259	*****	*****	*****	*****	*****
0.975	*****	-0.1897	-0.2411	-0.3203	-0.4445	*****	*****	*****	*****	*****
1.000	0.0864	-0.0063	-0.0344	-0.1474	-0.1753	*****	*****	*****	*****	*****
	$C_{p,l}$	$C_{p,l}$	$C_{p,l}$	$C_{p,l}$	$C_{p,l}$	$C_{p,l}$	$C_{p,l}$	$C_{p,l}$	$C_{p,l}$	$C_{p,l}$
-0.200	0.0364	0.0521	0.1304	*****	-0.4723	*****	*****	*****	*****	*****
-0.400	0.0251	0.0553	0.0893	-0.0603	-0.5546	*****	*****	*****	*****	*****
-0.600	0.0121	0.0482	0.0714	-0.0346	-0.6898	*****	*****	*****	*****	*****
-0.700	0.0260	0.0316	0.0596	-0.0265	-0.6984	*****	*****	*****	*****	*****
-0.800	0.0549	0.0261	0.0449	-0.0196	-0.6638	*****	*****	*****	*****	*****
-0.850	0.0802	0.0414	0.0393	-0.0253	-0.6804	*****	*****	*****	*****	*****
-0.900	*****	0.0722	0.0530	-0.0209	-0.6915	*****	*****	*****	*****	*****
-0.950	0.1634	0.1308	0.1107	0.0303	-0.2880	*****	*****	*****	*****	*****
-0.975	*****	0.1756	0.1580	0.0926	-0.1166	*****	*****	*****	*****	*****
-1.000	0.0982	0.0150	-0.0776	-0.1042	-0.1133	*****	*****	*****	*****	*****

Medium Radius L.E.
 Run No. = 8, Point No. = 153
 $C_N = 0.122$, $C_m = -0.0251$
 $\alpha = 3.1^\circ$, $M_\infty = 0.870$
 $R_{mac} = 6.0 \times 10^6$

Leading Edge Pressures

● starboard
 ○ port

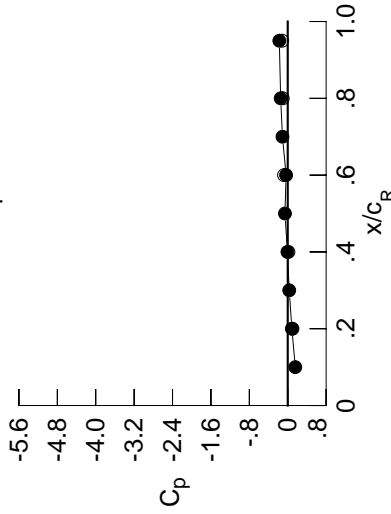

x/c_R	starb'd C_p	port C_p
0.10	0.1573	*****
0.20	0.0864	0.0982
0.30	0.0312	*****
0.40	-0.0063	0.0150
0.50	-0.0579	*****
0.60	-0.0344	-0.0776
0.70	-0.1094	*****
0.80	-0.1474	-0.1042
0.90	*****	*****
0.95	-0.1753	-0.1133

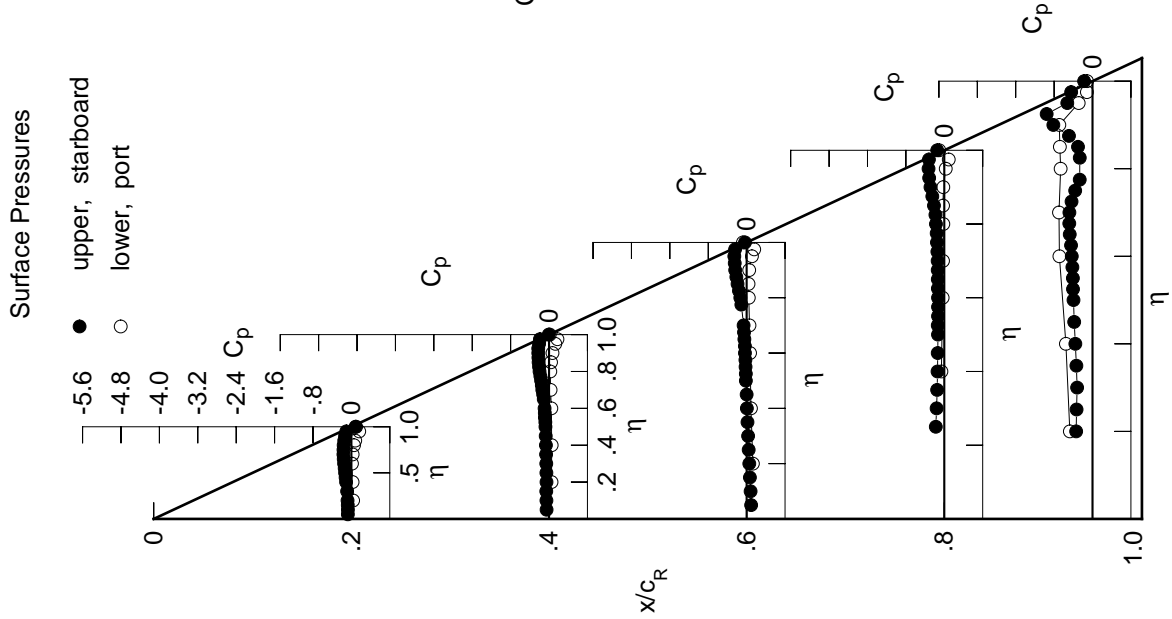

Table F3. Continued.

η	$x/c_R = .2$		$x/c_R = .4$		$x/c_R = .6$		$x/c_R = .8$		$x/c_R = .95$	
	$C_{p,u}$	$C_{p,u}$	$C_{p,u}$	$C_{p,u}$	$C_{p,u}$	$C_{p,u}$	$C_{p,u}$	$C_{p,u}$	$C_{p,u}$	$C_{p,u}$
0.050	-0.0907	-0.0689	0.0809	0.0809	0.0809	0.0809	0.0809	0.0809	0.0809	0.0809
0.100	-0.0906	-0.0723	0.0720	0.0720	0.0720	0.0720	0.0720	0.0720	0.0720	0.0720
0.150	-0.0973	-0.0763	0.0593	0.0593	0.0593	0.0593	0.0593	0.0593	0.0593	0.0593
0.200	-0.0978	-0.0706	0.0430	0.0430	0.0430	0.0430	0.0430	0.0430	0.0430	0.0430
0.250	*****	-0.0738	0.0298	0.0298	0.1894	0.1894	0.3167	0.3167	0.3167	0.3167
0.300	-0.1151	-0.0754	0.0166	0.0166	-0.1720	-0.1720	-0.3063	-0.3063	-0.3063	-0.3063
0.350	*****	-0.0796	0.0028	0.0028	-0.1614	-0.1614	-0.3121	-0.3121	-0.3121	-0.3121
0.400	-0.1338	-0.0830	-0.0090	-0.0090	-0.1545	-0.1545	-0.3359	-0.3359	-0.3359	-0.3359
0.450	-0.1452	-0.0899	-0.0160	-0.0160	-0.1492	-0.1492	-0.3543	-0.3543	-0.3543	-0.3543
0.500	-0.1565	-0.0954	-0.0306	-0.0306	-0.1467	-0.1467	-0.3713	-0.3713	-0.3713	-0.3713
0.525	*****	-0.1001	-0.0367	-0.0367	-0.1488	-0.1488	-0.3798	-0.3798	-0.3798	-0.3798
0.550	-0.1676	-0.1063	-0.0399	-0.0399	-0.1468	-0.1468	-0.3792	-0.3792	-0.3792	-0.3792
0.575	*****	-0.1134	-0.0453	-0.0453	-0.1464	-0.1464	-0.3891	-0.3891	-0.3891	-0.3891
0.600	-0.1821	-0.1164	-0.0519	-0.0519	-0.1505	-0.1505	-0.3982	-0.3982	-0.3982	-0.3982
0.625	*****	*****	-0.0599	-0.0599	-0.1505	-0.1505	-0.4115	-0.4115	-0.4115	-0.4115
0.650	-0.1934	-0.1386	-0.0663	-0.0663	-0.1539	-0.1539	-0.4296	-0.4296	-0.4296	-0.4296
0.675	*****	-0.1514	-0.0774	-0.0774	-0.1572	-0.1572	-0.4301	-0.4301	-0.4301	-0.4301
0.700	-0.2042	-0.1697	-0.0871	-0.0871	-0.1617	-0.1617	-0.4255	-0.4255	-0.4255	-0.4255
0.725	*****	-0.1833	*****	*****	-0.1669	-0.1669	-0.3927	-0.3927	-0.3927	-0.3927
0.750	-0.2061	-0.2046	*****	*****	-0.1766	-0.1766	-0.3343	-0.3343	-0.3343	-0.3343
0.775	*****	-0.2227	-0.1393	-0.1393	-0.1920	-0.1920	-0.2523	-0.2523	-0.2523	-0.2523
0.800	-0.2074	-0.2438	-0.1694	-0.1694	-0.2010	-0.2010	*****	*****	*****	*****
0.825	*****	-0.2597	-0.1995	-0.1995	-0.2167	-0.2167	-0.2598	-0.2598	-0.2598	-0.2598
0.850	-0.1999	-0.2736	-0.2360	-0.2360	-0.2549	-0.2549	-0.2883	-0.2883	-0.2883	-0.2883
0.875	*****	-0.2869	-0.2700	-0.2700	-0.2956	-0.2956	-0.4272	-0.4272	-0.4272	-0.4272
0.900	-0.1899	-0.2937	-0.3031	-0.3031	-0.3454	-0.3454	-0.7383	-0.7383	-0.7383	-0.7383
0.925	*****	-0.3013	-0.3304	-0.3304	-0.3883	-0.3883	-0.8988	-0.8988	-0.8988	-0.8988
0.950	-0.1773	-0.2982	-0.3515	-0.3515	-0.4219	-0.4219	-0.5842	-0.5842	-0.5842	-0.5842
0.975	*****	-0.3054	-0.3687	-0.3687	-0.4472	-0.4472	-0.5423	-0.5423	-0.5423	-0.5423
1.000	-0.0048	-0.1675	-0.1978	-0.1978	-0.3846	-0.3846	-0.3649	-0.3649	-0.3649	-0.3649
	$C_{p,l}$	$C_{p,l}$	$C_{p,l}$	$C_{p,l}$	$C_{p,l}$	$C_{p,l}$	$C_{p,l}$	$C_{p,l}$	$C_{p,l}$	$C_{p,l}$
-0.200	0.0595	0.0711	0.1440	0.1440	0.1440	0.1440	0.1440	0.1440	0.1440	0.1440
-0.400	0.0478	0.0768	0.1081	0.1081	0.0443	0.0443	0.5827	0.5827	0.5827	0.5827
-0.600	0.0425	0.0715	0.0912	0.0912	0.0153	0.0153	0.6962	0.6962	0.6962	0.6962
-0.700	0.0588	0.0605	0.0840	0.0840	0.0086	0.0086	0.6954	0.6954	0.6954	0.6954
-0.800	0.0887	0.0604	0.0726	0.0726	0.0045	0.0045	0.6470	0.6470	0.6470	0.6470
-0.850	0.1140	0.0788	0.0754	0.0754	0.0028	0.0028	0.6585	0.6585	0.6585	0.6585
-0.900	*****	0.1106	0.0912	0.0912	0.0144	0.0144	0.6814	0.6814	0.6814	0.6814
-0.950	0.1901	0.1643	0.1454	0.1454	0.0708	0.0708	0.2691	0.2691	0.2691	0.2691
-0.975	*****	0.1968	0.1838	0.1838	0.1261	0.1261	0.0943	0.0943	0.0943	0.0943
-1.000	0.0090	-0.1410	-0.3011	-0.3011	-0.3304	-0.3304	-0.2861	-0.2861	-0.2861	-0.2861

Medium Radius L.E.
 Run No. = 8, Point No. = 154
 $C_N = 0.169$, $C_m = -0.0343$
 $\alpha = 4.2^\circ$, $M_\infty = 0.870$
 $R_{mac} = 6.0 \times 10^6$

Leading Edge Pressures

● starboard
 ○ port

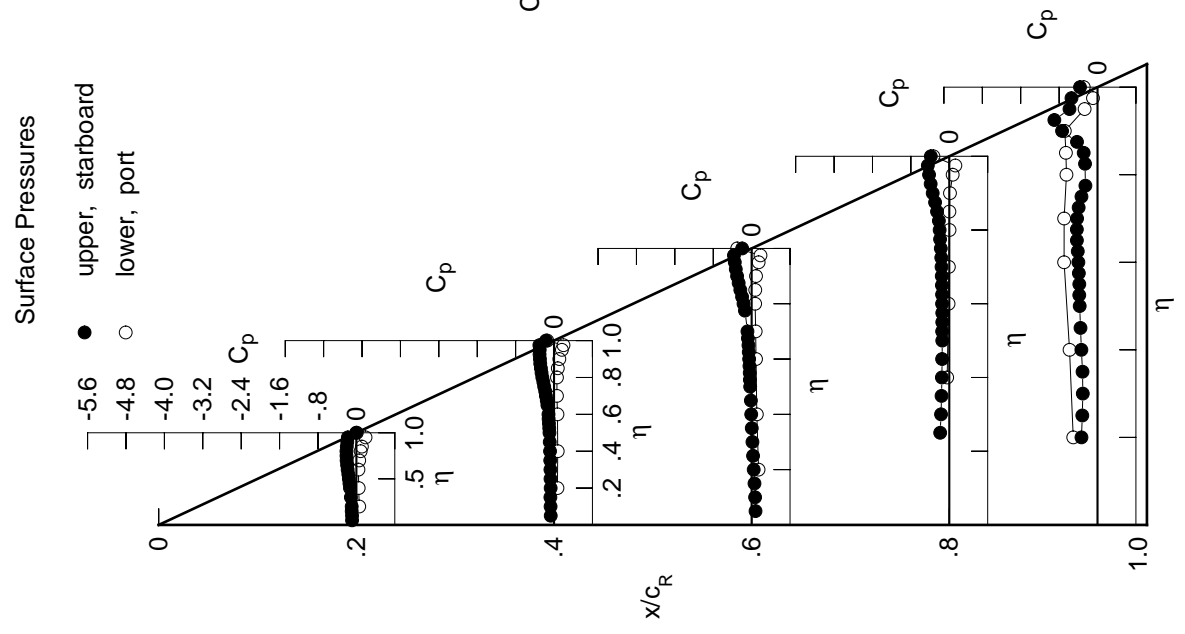
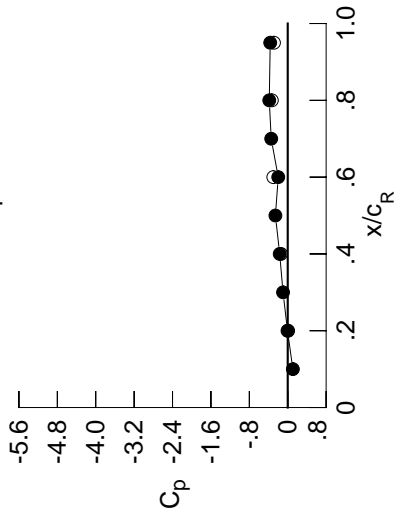
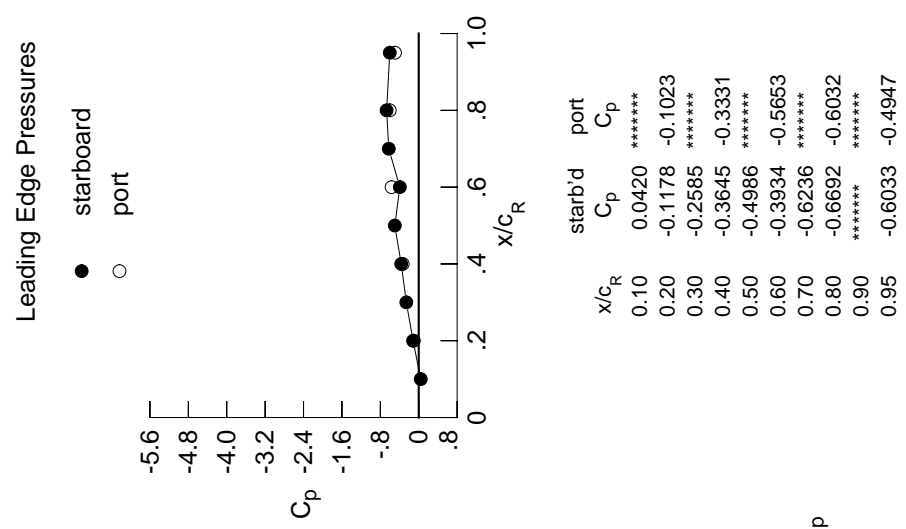

Table F3. Continued.

η	$x/c_R = .2$		$x/c_R = .4$		$x/c_R = .6$		$x/c_R = .8$		$x/c_R = .95$	
	$C_{p,u}$	$C_{p,u}$	$C_{p,u}$	$C_{p,u}$	$C_{p,u}$	$C_{p,u}$	$C_{p,u}$	$C_{p,u}$	$C_{p,u}$	$C_{p,u}$
0.050	-0.1104	-0.0852	0.0688	*****	*****	*****	*****	*****	*****	*****
0.100	-0.1058	-0.0889	0.0587	*****	*****	*****	*****	*****	*****	*****
0.150	-0.1139	-0.0914	0.0451	*****	*****	*****	*****	*****	*****	*****
0.200	-0.1161	-0.0880	0.0295	*****	*****	*****	*****	*****	*****	*****
0.250	*****	-0.0908	0.0167	-0.2033	-0.3079	*****	*****	*****	*****	*****
0.300	-0.1297	-0.0961	0.0030	-0.1848	-0.2912	*****	*****	*****	*****	*****
0.350	*****	-0.0981	-0.0097	-0.1762	-0.2945	*****	*****	*****	*****	*****
0.400	-0.1540	-0.1049	-0.0247	-0.1681	-0.3109	*****	*****	*****	*****	*****
0.450	-0.1670	-0.1098	-0.0318	-0.1658	-0.3360	*****	*****	*****	*****	*****
0.500	-0.1806	-0.1173	-0.0486	-0.1616	-0.3649	*****	*****	*****	*****	*****
0.525	*****	-0.1217	-0.0524	-0.1654	-0.3804	*****	*****	*****	*****	*****
0.550	-0.1935	-0.1316	-0.0586	-0.1614	-0.3853	*****	*****	*****	*****	*****
0.575	*****	-0.1371	-0.0637	-0.1644	-0.3968	*****	*****	*****	*****	*****
0.600	-0.2112	-0.1413	-0.0743	-0.1648	-0.4038	*****	*****	*****	*****	*****
0.625	*****	*****	-0.0792	-0.1692	-0.4141	*****	*****	*****	*****	*****
0.650	-0.2268	-0.1665	-0.0887	-0.1756	-0.4238	*****	*****	*****	*****	*****
0.675	*****	-0.1797	-0.1019	-0.1784	-0.4132	*****	*****	*****	*****	*****
0.700	-0.2405	-0.2013	-0.1136	-0.1853	-0.4078	*****	*****	*****	*****	*****
0.725	*****	-0.2200	*****	-0.1918	-0.3867	*****	*****	*****	*****	*****
0.750	-0.2472	-0.2399	*****	-0.2048	-0.3432	*****	*****	*****	*****	*****
0.775	*****	-0.2648	-0.1743	-0.2177	-0.2766	*****	*****	*****	*****	*****
0.800	-0.2537	-0.2882	-0.2016	-0.2346	*****	*****	*****	*****	*****	*****
0.825	*****	-0.3103	-0.2402	-0.2525	-0.2853	*****	*****	*****	*****	*****
0.850	-0.2531	-0.3330	-0.2849	-0.2931	-0.2929	*****	*****	*****	*****	*****
0.875	*****	-0.3502	-0.3267	-0.3419	-0.3626	*****	*****	*****	*****	*****
0.900	-0.2524	-0.3673	-0.3717	-0.4006	-0.5133	*****	*****	*****	*****	*****
0.925	*****	-0.3859	-0.4146	-0.4605	-0.6467	*****	*****	*****	*****	*****
0.950	-0.2537	-0.3966	-0.4569	-0.5171	-0.6473	*****	*****	*****	*****	*****
0.975	*****	-0.4296	-0.4962	-0.5647	-0.6396	*****	*****	*****	*****	*****
1.000	-0.1178	-0.3645	-0.3934	-0.6692	-0.6033	*****	*****	*****	*****	*****
	$C_{p,l}$	$C_{p,l}$	$C_{p,l}$	$C_{p,l}$	$C_{p,l}$	$C_{p,l}$	$C_{p,l}$	$C_{p,l}$	$C_{p,l}$	$C_{p,l}$
-0.200	0.0818	0.0889	0.1577	*****	-0.5090	*****	*****	*****	*****	*****
-0.400	0.0717	0.0954	0.1229	-0.0317	-0.6111	*****	*****	*****	*****	*****
-0.600	0.0743	0.0923	0.1072	-0.0010	-0.6917	*****	*****	*****	*****	*****
-0.700	0.0924	0.0857	0.1031	0.0089	-0.6852	*****	*****	*****	*****	*****
-0.800	0.1236	0.0925	0.0976	0.0248	-0.6320	*****	*****	*****	*****	*****
-0.850	0.1485	0.1147	0.1009	0.0262	-0.6409	*****	*****	*****	*****	*****
-0.900	*****	0.1460	0.1246	0.0438	-0.6496	*****	*****	*****	*****	*****
-0.950	0.2127	0.1911	0.1740	0.0994	-0.2516	*****	*****	*****	*****	*****
-0.975	*****	0.2095	0.1992	0.1431	-0.0786	*****	*****	*****	*****	*****
-1.000	-0.1023	-0.3331	-0.5653	-0.6032	-0.4947	*****	*****	*****	*****	*****

Medium Radius L.E.
 Run No. = 8, Point No. = 155
 $C_N = 0.212$, $C_m = -0.0426$
 $\alpha = 5.2^\circ$, $M_\infty = 0.870$
 $R_{mac} = 6.0 \times 10^6$



x/c_R	starb'd C_p	port C_p
0.10	0.0420	*****
0.20	-0.1178	-0.1023
0.30	-0.2585	*****
0.40	-0.3645	-0.3331
0.50	-0.4986	*****
0.60	-0.3934	-0.5653
0.70	-0.6236	*****
0.80	-0.6692	-0.6032
0.90	*****	*****
0.95	-0.6033	-0.4947

Table F3. Continued.

η	$x/c_R = .2$		$x/c_R = .4$		$x/c_R = .6$		$x/c_R = .8$		$x/c_R = .95$	
	$C_{p,u}$	$C_{p,u}$	$C_{p,u}$	$C_{p,u}$	$C_{p,u}$	$C_{p,u}$	$C_{p,u}$	$C_{p,u}$	$C_{p,u}$	$C_{p,u}$
0.050	-0.1269	-0.1034	0.0568	*****	*****	*****	*****	*****	*****	
0.100	-0.1259	-0.1049	0.0467	*****	*****	*****	*****	*****	*****	
0.150	-0.1332	-0.1076	0.0320	*****	*****	*****	*****	*****	*****	
0.200	-0.1376	-0.1075	0.0157	*****	*****	*****	*****	*****	-0.3267	
0.250	*****	-0.1091	0.0037	-0.2207	-0.3011	*****	*****	*****	*****	
0.300	-0.1513	-0.1147	-0.0125	-0.2028	-0.2833	*****	*****	*****	*****	
0.350	*****	-0.1195	-0.0250	-0.1914	-0.2866	*****	*****	*****	*****	
0.400	-0.1787	-0.1258	-0.0395	-0.1853	-0.3068	*****	*****	*****	*****	
0.450	-0.1923	-0.1335	-0.0490	-0.1807	-0.3419	*****	*****	*****	*****	
0.500	-0.2078	-0.1409	-0.0667	-0.1795	-0.3734	*****	*****	*****	*****	
0.525	*****	-0.1472	-0.0711	-0.1818	-0.3997	*****	*****	*****	*****	
0.550	-0.2224	-0.1570	-0.0794	-0.1814	-0.4224	*****	*****	*****	*****	
0.575	*****	-0.1634	-0.0839	-0.1836	-0.4577	*****	*****	*****	*****	
0.600	-0.2427	-0.1705	-0.1005	-0.1853	-0.4860	*****	*****	*****	*****	
0.625	*****	*****	-0.1039	-0.1917	-0.5027	*****	*****	*****	*****	
0.650	-0.2612	-0.1960	-0.1165	-0.1996	-0.5269	*****	*****	*****	*****	
0.675	*****	-0.2120	-0.1298	-0.2066	-0.5143	*****	*****	*****	*****	
0.700	-0.2789	-0.2396	-0.1479	-0.2185	-0.4923	*****	*****	*****	*****	
0.725	*****	-0.2559	*****	-0.2303	-0.4627	*****	*****	*****	*****	
0.750	-0.2919	-0.2802	*****	-0.2474	-0.4280	*****	*****	*****	*****	
0.775	*****	-0.3082	-0.2119	-0.2686	-0.3753	*****	*****	*****	*****	
0.800	-0.3030	-0.3369	-0.2437	-0.2814	*****	*****	*****	*****	*****	
0.825	*****	-0.3638	-0.2821	-0.3007	-0.3505	*****	*****	*****	*****	
0.850	-0.3101	-0.3918	-0.3312	-0.3332	-0.3136	*****	*****	*****	*****	
0.875	*****	-0.4209	-0.3824	-0.3816	-0.2917	*****	*****	*****	*****	
0.900	-0.3204	-0.4460	-0.4407	-0.4486	-0.3047	*****	*****	*****	*****	
0.925	*****	-0.4739	-0.4962	-0.5256	-0.3101	*****	*****	*****	*****	
0.950	-0.3400	-0.4911	-0.5622	-0.6141	-0.6321	*****	*****	*****	*****	
0.975	*****	-0.5766	-0.6259	-0.6956	-0.7659	*****	*****	*****	*****	
1.000	-0.2545	-0.6025	-0.5994	-0.9134	-0.8394	*****	*****	*****	*****	
-0.200	$C_{p,l}$	$C_{p,l}$	$C_{p,l}$	$C_{p,l}$	$C_{p,l}$	$C_{p,l}$	$C_{p,l}$	$C_{p,l}$	$C_{p,l}$	
-0.400	0.1019	0.1070	0.1693	*****	*****	*****	*****	*****	-0.5530	
-0.600	0.0935	0.1149	0.1364	-0.0191	-0.6346	*****	*****	*****	*****	
-0.700	0.1009	0.1129	0.1224	0.0114	-0.6882	*****	*****	*****	*****	
-0.800	0.1202	0.1088	0.1208	0.0224	-0.6762	*****	*****	*****	*****	
-0.850	0.1517	0.1191	0.1200	0.0399	-0.6186	*****	*****	*****	*****	
-0.900	0.1757	0.1449	0.1271	0.0480	-0.6219	*****	*****	*****	*****	
-0.950	*****	0.1737	0.1498	0.0689	-0.6209	*****	*****	*****	*****	
-0.975	0.2261	0.2099	0.1939	0.1214	-0.2383	*****	*****	*****	*****	
-1.000	*****	0.2099	0.2008	0.1511	-0.0735	*****	*****	*****	*****	
	-0.2398	-0.5645	-0.8125	-0.8515	-0.7233	*****	*****	*****	*****	

Medium Radius L.E.
 Run No. = 8, Point No. = 156
 $C_N = 0.251$, $C_m = -0.0457$
 $\alpha = 6.2^\circ$, $M_\infty = 0.871$
 $R_{mac} = 6.0 \times 10^6$

Leading Edge Pressures

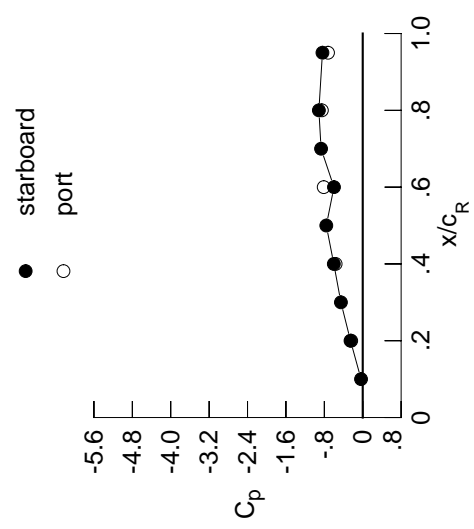

x/c_R	starb'd C_p	port C_p
0.10	-0.0349	*****
0.20	-0.2545	-0.2398
0.30	-0.4547	*****
0.40	-0.6025	-0.5645
0.50	-0.7588	*****
0.60	-0.5994	-0.8125
0.70	-0.8678	*****
0.80	-0.9134	-0.8515
0.90	*****	*****
0.95	-0.8394	-0.7233

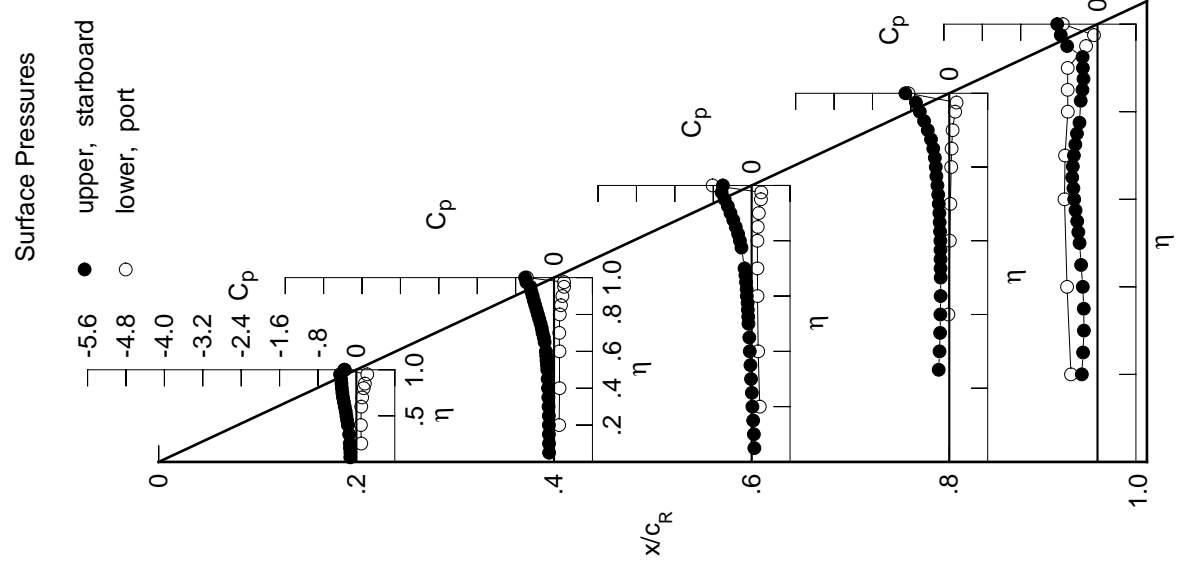
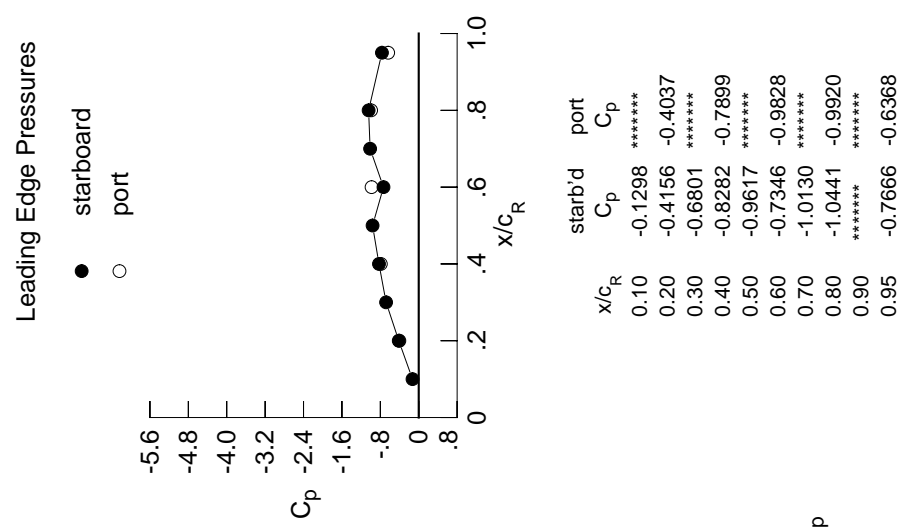

Table F3. Continued.

η	$x/c_R = .2$		$x/c_R = .4$		$x/c_R = .6$		$x/c_R = .8$		$x/c_R = .95$	
	$C_{p,u}$	$C_{p,u}$	$C_{p,u}$	$C_{p,u}$	$C_{p,u}$	$C_{p,u}$	$C_{p,u}$	$C_{p,u}$	$C_{p,u}$	$C_{p,u}$
0.050	-0.1436	-0.1201	0.0460	*****	*****	*****	*****	*****	*****	*****
0.100	-0.1445	-0.1243	0.0340	*****	*****	*****	*****	*****	*****	*****
0.150	-0.1518	-0.1279	0.0167	*****	*****	*****	*****	*****	*****	*****
0.200	-0.1551	-0.1252	0.0044	*****	*****	*****	*****	*****	*****	-0.2909
0.250	*****	-0.1277	-0.0095	-0.2356	-0.2744	*****	*****	*****	*****	-0.2744
0.300	-0.1693	-0.1330	-0.0245	-0.2170	-0.2717	*****	*****	*****	*****	-0.2717
0.350	*****	-0.1389	-0.0393	-0.2086	-0.2767	*****	*****	*****	*****	-0.2767
0.400	-0.1987	-0.1456	-0.0551	-0.2026	-0.2857	*****	*****	*****	*****	-0.2857
0.450	-0.2113	-0.1561	-0.0655	-0.1992	-0.3172	*****	*****	*****	*****	-0.3172
0.500	-0.2311	-0.1644	-0.0834	-0.1950	-0.3797	*****	*****	*****	*****	-0.3797
0.525	*****	-0.1729	-0.0907	-0.1988	-0.4363	*****	*****	*****	*****	-0.4363
0.550	-0.2493	-0.1850	-0.0997	-0.1966	-0.4881	*****	*****	*****	*****	-0.4881
0.575	*****	-0.1907	-0.1064	-0.2002	-0.5657	*****	*****	*****	*****	-0.5657
0.600	-0.2733	-0.2012	-0.1242	-0.2039	-0.6365	*****	*****	*****	*****	-0.6365
0.625	*****	*****	-0.1363	-0.2135	-0.6704	*****	*****	*****	*****	-0.6704
0.650	-0.2967	-0.2255	-0.1504	-0.2278	-0.6591	*****	*****	*****	*****	-0.6591
0.675	*****	-0.2481	-0.1705	-0.2468	-0.5860	*****	*****	*****	*****	-0.5860
0.700	-0.3182	-0.2688	-0.1948	-0.2742	-0.5265	*****	*****	*****	*****	-0.5265
0.725	*****	-0.2919	*****	-0.3007	-0.4838	*****	*****	*****	*****	-0.4838
0.750	-0.3348	-0.3193	*****	-0.3174	-0.4567	*****	*****	*****	*****	-0.4567
0.775	*****	-0.3504	-0.2618	-0.3242	-0.4578	*****	*****	*****	*****	-0.4578
0.800	-0.3533	-0.3835	-0.2857	-0.3400	*****	*****	*****	*****	*****	*****
0.825	*****	-0.4177	-0.3206	-0.3670	-0.5574	*****	*****	*****	*****	-0.5574
0.850	-0.3684	-0.4532	-0.3690	-0.3997	-0.6207	*****	*****	*****	*****	-0.6207
0.875	*****	-0.4928	-0.4228	-0.4483	-0.7082	*****	*****	*****	*****	-0.7082
0.900	-0.3926	-0.5279	-0.4878	-0.5345	-0.6849	*****	*****	*****	*****	-0.6849
0.925	*****	-0.5757	-0.5605	-0.6544	-0.5667	*****	*****	*****	*****	-0.5667
0.950	-0.4370	-0.6100	-0.6452	-0.7705	-0.5516	*****	*****	*****	*****	-0.5516
0.975	*****	-0.6572	-0.8381	-0.8644	-0.5966	*****	*****	*****	*****	-0.5966
1.000	-0.4156	-0.8282	-0.7346	-1.0441	-0.7666	*****	*****	*****	*****	-0.7666
-0.200	$C_{p,l}$	$C_{p,l}$	$C_{p,l}$	$C_{p,l}$	$C_{p,l}$	$C_{p,l}$	$C_{p,l}$	$C_{p,l}$	$C_{p,l}$	$C_{p,l}$
-0.400	0.1256	0.1286	0.1876	*****	*****	*****	*****	*****	*****	-0.5704
-0.600	0.1196	0.1366	0.1561	-0.0020	-0.6512	*****	*****	*****	*****	-0.6512
-0.700	0.1292	0.1373	0.1443	0.0302	-0.6754	*****	*****	*****	*****	-0.6754
-0.800	0.1491	0.1351	0.1424	0.0433	-0.6602	*****	*****	*****	*****	-0.6602
-0.850	0.1811	0.1501	0.1450	0.0638	-0.6019	*****	*****	*****	*****	-0.6019
-0.900	0.2023	0.1726	0.1540	0.0724	-0.6009	*****	*****	*****	*****	-0.6009
-0.950	*****	0.2000	0.1761	0.0952	-0.5919	*****	*****	*****	*****	-0.5919
-0.975	0.2353	0.2235	0.2096	0.1429	-0.2183	*****	*****	*****	*****	-0.2183
-1.000	*****	0.2049	0.1984	0.1563	-0.0532	*****	*****	*****	*****	-0.0532
	-0.4037	-0.7899	-0.9828	-0.9920	-0.6368	*****	*****	*****	*****	-0.6368

Medium Radius L.E.
 Run No. = 8, Point No. = 157
 $C_N = 0.306$, $C_m = -0.0593$
 $\alpha = 7.3^\circ$, $M_\infty = 0.870$
 $R_{mac} = 6.0 \times 10^6$



x/c_R	starb'd C_p	port C_p
0.10	-0.1298	*****
0.20	-0.4156	-0.4037
0.30	-0.6801	*****
0.40	-0.8282	-0.7899
0.50	-0.9617	*****
0.60	-0.7346	-0.9828
0.70	-1.0130	*****
0.80	-1.0441	-0.9920
0.90	*****	*****
0.95	-0.7666	-0.6368

Table F3. Continued.

η	$x/c_R = .2$		$x/c_R = .4$		$x/c_R = .6$		$x/c_R = .8$		$x/c_R = .95$	
	$C_{p,u}$	$C_{p,u}$	$C_{p,u}$	$C_{p,u}$	$C_{p,u}$	$C_{p,u}$	$C_{p,u}$	$C_{p,u}$	$C_{p,u}$	$C_{p,u}$
0.050	-0.1601	-0.1406	0.0285	*****	*****	*****	*****	*****	*****	
0.100	-0.1620	-0.1439	0.0175	*****	*****	*****	*****	*****	*****	
0.150	-0.1709	-0.1471	0.0016	*****	*****	*****	*****	*****	*****	
0.200	-0.1727	-0.1425	-0.0110	*****	*****	*****	*****	*****	-0.2887	
0.250	*****	-0.1483	-0.0283	-0.2651	-0.2680	*****	*****	*****	*****	
0.300	-0.1900	-0.1516	-0.0436	-0.2473	-0.2446	*****	*****	*****	*****	
0.350	*****	-0.1601	-0.0581	-0.2373	-0.2505	*****	*****	*****	*****	
0.400	-0.2200	-0.1692	-0.0744	-0.2296	-0.2840	*****	*****	*****	*****	
0.450	-0.2376	-0.1826	-0.0846	-0.2252	-0.3384	*****	*****	*****	*****	
0.500	-0.2572	-0.1950	-0.1063	-0.2195	-0.3584	*****	*****	*****	*****	
0.525	*****	-0.2038	-0.1157	-0.2257	-0.3212	*****	*****	*****	*****	
0.550	-0.2777	-0.2175	-0.1306	-0.2369	-0.2341	*****	*****	*****	*****	
0.575	*****	-0.2264	-0.1425	-0.2596	-0.2287	*****	*****	*****	*****	
0.600	-0.3045	-0.2390	-0.1690	-0.2783	-0.2889	*****	*****	*****	*****	
0.625	*****	*****	-0.1888	-0.2662	-0.3793	*****	*****	*****	*****	
0.650	-0.3323	-0.2707	-0.2133	-0.2517	-0.5415	*****	*****	*****	*****	
0.675	*****	-0.2879	-0.2379	-0.2448	-0.7087	*****	*****	*****	*****	
0.700	-0.3584	-0.3089	-0.2535	-0.2382	-0.7606	*****	*****	*****	*****	
0.725	*****	-0.3317	*****	-0.2325	-0.7378	*****	*****	*****	*****	
0.750	-0.3822	-0.3586	*****	-0.2201	-0.7753	*****	*****	*****	*****	
0.775	*****	-0.3912	-0.2884	-0.2056	-0.9874	*****	*****	*****	*****	
0.800	-0.4067	-0.4276	-0.3120	-0.4518	*****	*****	*****	*****	*****	
0.825	*****	-0.4685	-0.3494	-0.8320	-1.0545	*****	*****	*****	*****	
0.850	-0.4294	-0.5123	-0.4247	-0.8902	-0.8821	*****	*****	*****	*****	
0.875	*****	-0.5572	-0.5922	-0.8537	-0.7619	*****	*****	*****	*****	
0.900	-0.4540	-0.6017	-0.7976	-0.8070	-0.7072	*****	*****	*****	*****	
0.925	*****	-0.6573	-0.9097	-0.7569	-0.6933	*****	*****	*****	*****	
0.950	-0.5451	-0.7052	-0.9400	-0.7301	-0.6067	*****	*****	*****	*****	
0.975	*****	-1.0683	-0.9343	-0.7250	-0.5564	*****	*****	*****	*****	
1.000	-0.5980	-1.0016	-0.7678	-0.8525	-0.5846	*****	*****	*****	*****	
-0.200	$C_{p,l}$	$C_{p,l}$	$C_{p,l}$	$C_{p,l}$	$C_{p,l}$	$C_{p,l}$	$C_{p,l}$	$C_{p,l}$	$C_{p,l}$	
-0.400	0.1490	0.1514	0.2058	*****	-0.5852	*****	*****	*****	*****	
-0.600	0.1445	0.1573	0.1738	0.0147	-0.6578	*****	*****	*****	*****	
-0.700	0.1564	0.1620	0.1639	0.0458	-0.6682	*****	*****	*****	*****	
-0.800	0.1766	0.1623	0.1641	0.0610	-0.6492	*****	*****	*****	*****	
-0.850	0.2075	0.1779	0.1694	0.0831	-0.5899	*****	*****	*****	*****	
-0.880	0.2251	0.1988	0.1804	0.0924	-0.5886	*****	*****	*****	*****	
-0.900	*****	0.2229	0.2018	0.1162	-0.5772	*****	*****	*****	*****	
-0.950	0.2395	0.2341	0.2247	0.1575	-0.2167	*****	*****	*****	*****	
-0.975	*****	0.1951	0.1993	0.1608	-0.0632	*****	*****	*****	*****	
-1.000	-0.5965	-0.9570	-1.0539	-0.8650	-0.6126	*****	*****	*****	*****	

Medium Radius L.E.
 Run No. = 8, Point No. = 158
 $C_N = 0.372$, $C_m = -0.0771$
 $\alpha = 8.3^\circ$, $M_\infty = 0.870$
 $R_{mac} = 6.0 \times 10^6$

Leading Edge Pressures

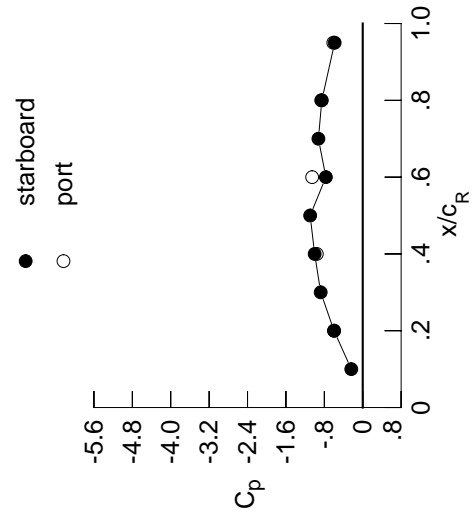

x/c_R	starb'd C_p	port C_p
0.10	-0.2383	*****
0.20	-0.5980	-0.5965
0.30	-0.8758	*****
0.40	-1.0016	-0.9570
0.50	-1.0955	*****
0.60	-0.7678	-1.0539
0.70	-0.9233	*****
0.80	-0.8525	-0.8650
0.90	*****	*****
0.95	-0.5846	-0.6126

Surface Pressures

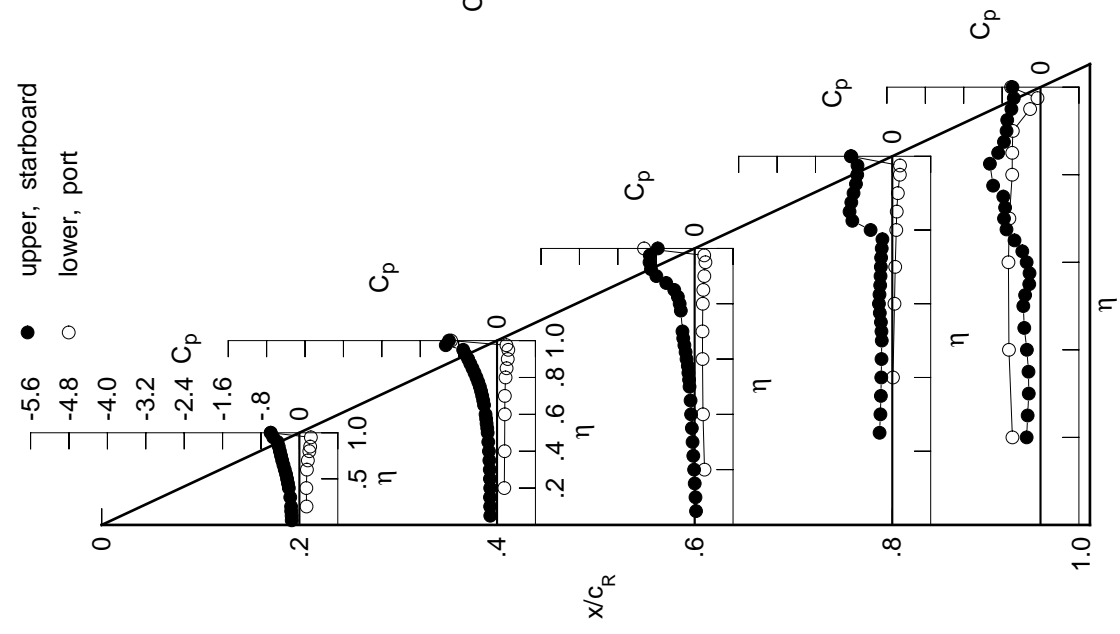

Table F3. Continued.

η	$x/c_R = .2$		$x/c_R = .4$		$x/c_R = .6$		$x/c_R = .8$		$x/c_R = .95$	
	$C_{p,u}$	$C_{p,u}$	$C_{p,u}$	$C_{p,u}$	$C_{p,u}$	$C_{p,u}$	$C_{p,u}$	$C_{p,u}$	$C_{p,u}$	$C_{p,u}$
0.050	-0.1747	-0.1607	0.0135	*****	*****	*****	*****	*****	*****	*****
0.100	-0.1781	-0.1652	0.0001	*****	*****	*****	*****	*****	*****	*****
0.150	-0.1847	-0.1684	-0.0156	*****	*****	*****	*****	*****	*****	*****
0.200	-0.1895	-0.1631	-0.0315	*****	*****	*****	*****	*****	*****	-0.2890
0.250	*****	-0.1702	-0.0448	-0.2901	-0.2418	*****	*****	*****	*****	*****
0.300	-0.2073	-0.1752	-0.0608	-0.2714	-0.2212	*****	*****	*****	*****	*****
0.350	*****	-0.1847	-0.0757	-0.2590	-0.2487	*****	*****	*****	*****	*****
0.400	-0.2383	-0.1940	-0.0909	-0.2502	-0.3070	*****	*****	*****	*****	*****
0.450	-0.2601	-0.2092	-0.1033	-0.2596	-0.2694	*****	*****	*****	*****	*****
0.500	-0.2806	-0.2279	-0.1366	-0.2780	-0.2929	*****	*****	*****	*****	*****
0.525	*****	-0.2441	-0.1623	-0.2584	-0.3445	*****	*****	*****	*****	*****
0.550	-0.3035	-0.2617	-0.1892	-0.2496	-0.4158	*****	*****	*****	*****	*****
0.575	*****	-0.2708	-0.2007	-0.2466	-0.5516	*****	*****	*****	*****	*****
0.600	-0.3330	-0.2850	-0.2000	-0.2419	-0.6784	*****	*****	*****	*****	*****
0.625	*****	*****	-0.1892	-0.2368	-0.7328	*****	*****	*****	*****	*****
0.650	-0.3652	-0.3184	-0.1882	-0.2304	-0.7387	*****	*****	*****	*****	*****
0.675	*****	-0.3349	-0.1913	-0.2200	-0.7221	*****	*****	*****	*****	*****
0.700	-0.3943	-0.3551	-0.1918	-0.2074	-0.7663	*****	*****	*****	*****	*****
0.725	*****	-0.3742	*****	-0.2408	-0.8827	*****	*****	*****	*****	*****
0.750	-0.4226	-0.4015	*****	-0.4729	-0.9729	*****	*****	*****	*****	*****
0.775	*****	-0.4343	-0.1988	-0.8273	-0.9204	*****	*****	*****	*****	*****
0.800	-0.4582	-0.4708	-0.6565	-0.9669	*****	*****	*****	*****	*****	*****
0.825	*****	-0.5107	-0.9529	-0.9991	-0.6819	*****	*****	*****	*****	*****
0.850	-0.4982	-0.5601	-0.9866	-0.9113	-0.6241	*****	*****	*****	*****	*****
0.875	*****	-0.6271	-0.9673	-0.7826	-0.6179	*****	*****	*****	*****	*****
0.900	-0.5363	-0.7315	-0.9274	-0.7335	-0.6338	*****	*****	*****	*****	*****
0.925	*****	-0.8775	-0.8771	-0.7057	-0.6628	*****	*****	*****	*****	*****
0.950	-0.5971	-1.0238	-0.8471	-0.7092	-0.5926	*****	*****	*****	*****	*****
0.975	*****	-1.1631	-0.8331	-0.6928	-0.5367	*****	*****	*****	*****	*****
1.000	-0.7612	-1.1118	-0.7303	-0.7822	-0.5248	*****	*****	*****	*****	*****
-0.200	$C_{p,l}$	0.1774	0.1793	0.2248	*****	*****	*****	*****	*****	-0.5868
-0.400	$C_{p,l}$	0.1750	0.1848	0.1935	0.0325	-0.6756	*****	*****	*****	*****
-0.600	$C_{p,l}$	0.1895	0.1908	0.1861	0.0651	-0.6562	*****	*****	*****	*****
-0.700	$C_{p,l}$	0.2057	0.1927	0.1890	0.0789	-0.6367	*****	*****	*****	*****
-0.800	$C_{p,l}$	0.2339	0.2078	0.1941	0.1028	-0.5777	*****	*****	*****	*****
-0.850	$C_{p,l}$	0.2497	0.2271	0.2061	0.1123	-0.5756	*****	*****	*****	*****
-0.900	$C_{p,l}$	*****	0.2463	0.2223	0.1356	-0.5622	*****	*****	*****	*****
-0.950	$C_{p,l}$	0.2428	0.2452	0.2370	0.1668	-0.2085	*****	*****	*****	*****
-0.975	$C_{p,l}$	*****	0.1876	0.1974	0.1589	-0.0594	*****	*****	*****	*****
-1.000	$C_{p,l}$	-0.7788	-1.0558	-0.9286	-0.7584	-0.5813	*****	*****	*****	*****

Medium Radius L.E.
 Run No. = 8, Point No. = 159
 $C_N = 0.425$, $C_m = -0.0838$
 $\alpha = 9.3^\circ$, $M_\infty = 0.869$
 $R_{mac} = 6.0 \times 10^6$

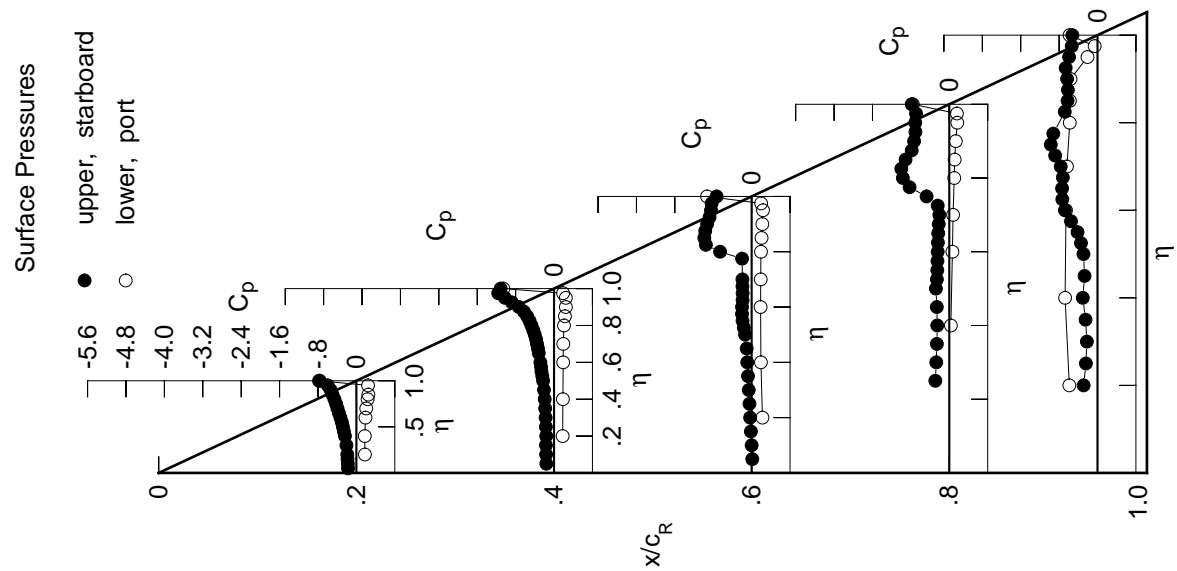
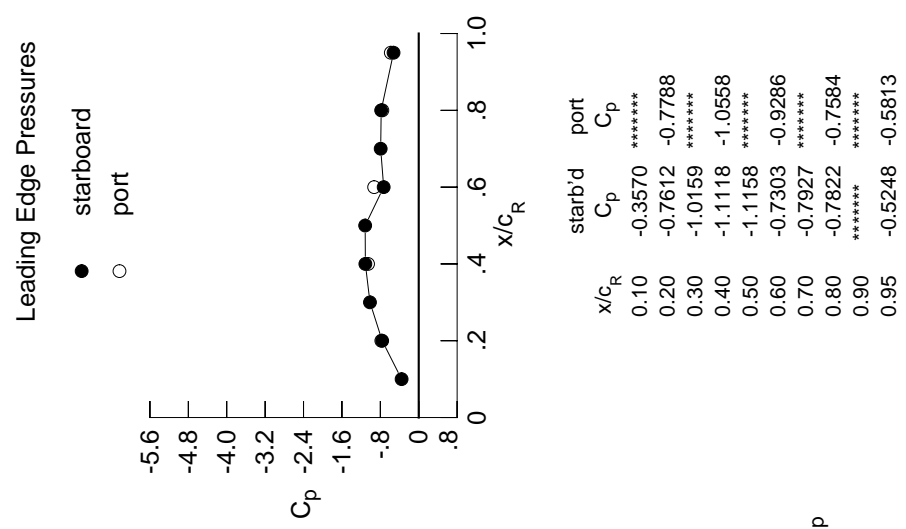

Table F3. Continued.

η	$x/c_R = .2$		$x/c_R = .4$		$x/c_R = .6$		$x/c_R = .8$		$x/c_R = .95$	
	$C_{p,u}$	$C_{p,u}$	$C_{p,u}$	$C_{p,u}$	$C_{p,u}$	$C_{p,u}$	$C_{p,u}$	$C_{p,u}$	$C_{p,u}$	$C_{p,u}$
0.050	-0.1959	-0.1879	-0.0085	*****	*****	*****	*****	*****	*****	*****
0.100	-0.1976	-0.1918	-0.0206	*****	*****	*****	*****	*****	*****	*****
0.150	-0.2051	-0.1936	-0.0398	*****	*****	*****	*****	*****	*****	*****
0.200	-0.2111	-0.1914	-0.0542	*****	*****	*****	*****	*****	*****	-0.2690
0.250	*****	-0.1988	-0.0680	-0.3193	-0.2977	-0.2708	*****	*****	*****	*****
0.300	-0.2300	-0.2044	-0.0843	-0.2977	-0.2708	*****	*****	*****	*****	*****
0.350	*****	-0.2123	-0.1000	-0.2893	-0.3013	*****	*****	*****	*****	*****
0.400	-0.2664	-0.2272	-0.1304	-0.3005	-0.2449	*****	*****	*****	*****	*****
0.450	-0.2868	-0.2527	-0.1688	-0.2769	-0.3132	*****	*****	*****	*****	*****
0.500	-0.3086	-0.2773	-0.1684	-0.2670	-0.4667	*****	*****	*****	*****	*****
0.525	*****	-0.2909	-0.1613	-0.2664	-0.6028	*****	*****	*****	*****	*****
0.550	-0.3356	-0.3151	-0.1647	-0.2579	-0.6793	*****	*****	*****	*****	*****
0.575	*****	-0.3211	-0.1609	-0.2540	-0.7085	*****	*****	*****	*****	*****
0.600	-0.3659	-0.3234	-0.1705	-0.2441	-0.6976	*****	*****	*****	*****	*****
0.625	*****	*****	-0.1678	-0.2373	-0.6858	*****	*****	*****	*****	*****
0.650	-0.4025	-0.3332	-0.1671	-0.2394	-0.7095	*****	*****	*****	*****	*****
0.675	*****	-0.3437	-0.1601	-0.2795	-0.7823	*****	*****	*****	*****	*****
0.700	-0.4366	-0.3633	-0.1542	-0.4379	-0.9149	*****	*****	*****	*****	*****
0.725	*****	-0.3812	*****	-0.7148	-0.9918	*****	*****	*****	*****	*****
0.750	-0.4788	-0.4100	*****	-0.9584	-0.8033	*****	*****	*****	*****	*****
0.775	*****	-0.4666	-1.0347	-1.0738	-0.6494	*****	*****	*****	*****	*****
0.800	-0.5215	-0.6002	-1.1015	-1.0325	*****	*****	*****	*****	*****	*****
0.825	*****	-0.7876	-1.0843	-0.8600	-0.5860	*****	*****	*****	*****	*****
0.850	-0.5650	-0.9345	-1.0373	-0.7814	-0.5735	*****	*****	*****	*****	*****
0.875	*****	-1.0206	-0.9591	-0.7730	-0.5826	*****	*****	*****	*****	*****
0.900	-0.6173	-1.0555	-0.8640	-0.7294	-0.5921	*****	*****	*****	*****	*****
0.925	*****	-1.0634	-0.8137	-0.7089	-0.5918	*****	*****	*****	*****	*****
0.950	-0.7014	-1.0554	-0.7803	-0.7443	-0.5185	*****	*****	*****	*****	*****
0.975	*****	-1.0544	-0.7621	-0.7219	-0.4444	*****	*****	*****	*****	*****
1.000	-0.8906	-1.1518	-0.6799	-0.7828	-0.4423	*****	*****	*****	*****	*****
-0.200	$C_{p,l}$	$C_{p,l}$	$C_{p,l}$	$C_{p,l}$	$C_{p,l}$	$C_{p,l}$	$C_{p,l}$	$C_{p,l}$	$C_{p,l}$	$C_{p,l}$
-0.400	0.2020	0.1978	0.2397	*****	*****	*****	*****	*****	*****	-0.5939
-0.600	0.2020	0.2081	0.2110	0.0472	-0.6676	*****	*****	*****	*****	*****
-0.700	0.2176	0.2127	0.2030	0.0785	-0.6480	*****	*****	*****	*****	*****
-0.800	0.2369	0.2176	0.2061	0.0924	-0.6281	*****	*****	*****	*****	*****
-0.850	0.2603	0.2345	0.2135	0.1170	-0.5647	*****	*****	*****	*****	*****
-0.900	0.2728	0.2523	0.2252	0.1285	-0.5615	*****	*****	*****	*****	*****
-0.950	0.2428	0.2522	0.2450	0.1743	-0.5380	*****	*****	*****	*****	*****
-0.975	*****	0.1784	0.1917	0.1541	-0.0541	*****	*****	*****	*****	*****
-1.000	-0.9125	-1.1099	-0.8558	-0.7698	-0.4840	*****	*****	*****	*****	*****

Medium Radius L.E.
 Run No. = 8, Point No. = 160
 $C_N = 0.482$, $C_m = -0.0939$
 $\alpha = 10.4^\circ$, $M_\infty = 0.870$
 $R_{mac} = 6.0 \times 10^6$

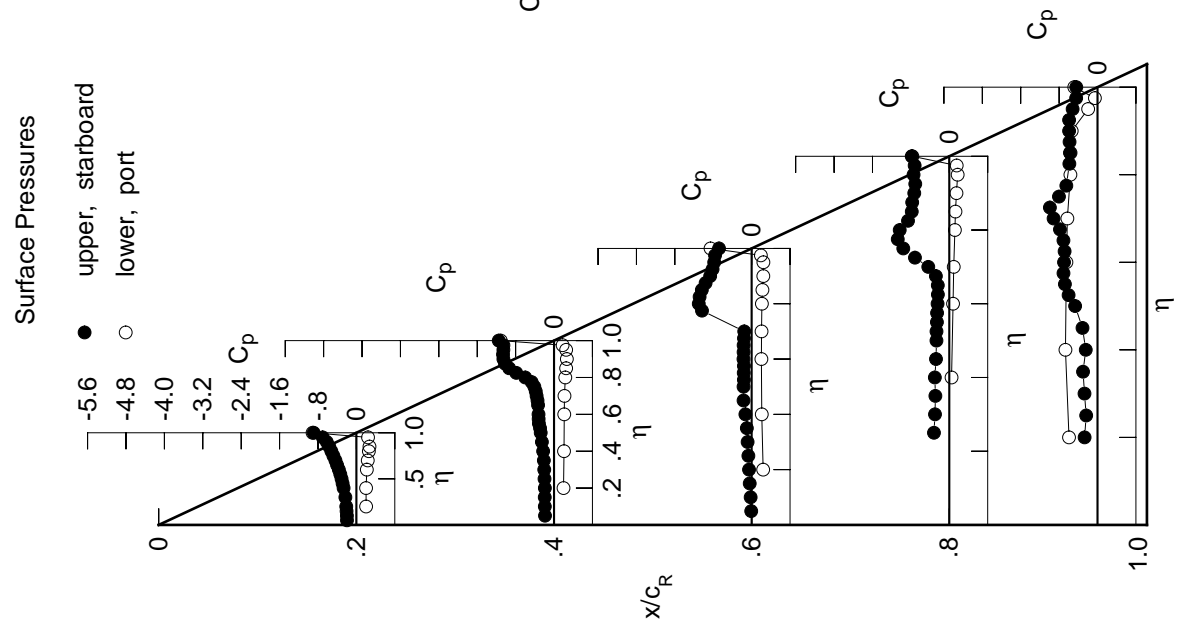
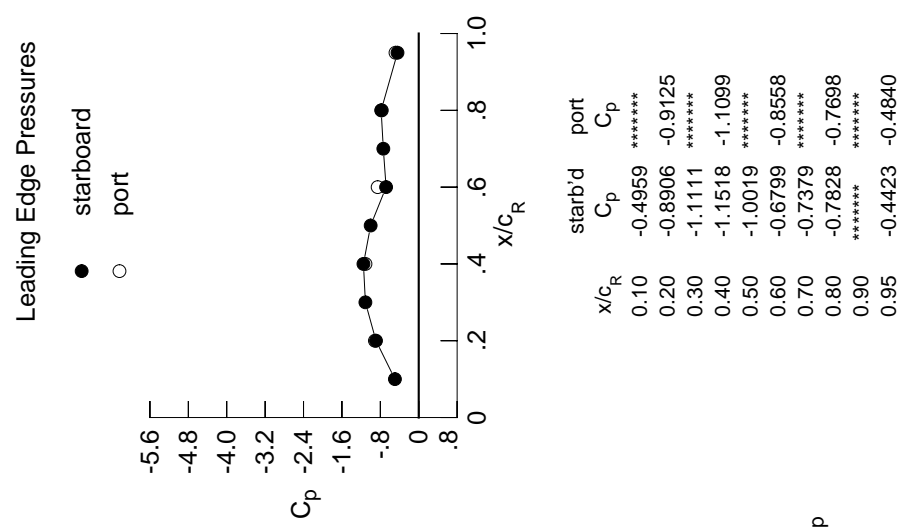

Table F3. Continued.

η	x/c_R .2	x/c_R .4	x/c_R .6	x/c_R .8	x/c_R .95
	$C_{p,u}$	$C_{p,u}$	$C_{p,u}$	$C_{p,u}$	$C_{p,u}$
0.050	-0.2104	-0.2115	-0.0268	*****	*****
0.100	-0.2167	-0.2154	-0.0403	*****	*****
0.150	-0.2252	-0.2185	-0.0605	*****	*****
0.200	-0.2302	-0.2163	-0.0740	*****	-0.2949
0.250	*****	-0.2227	-0.0892	-0.3371	-0.2828
0.300	-0.2541	-0.2252	-0.1058	-0.3248	-0.2892
0.350	*****	-0.2400	-0.1484	-0.3254	-0.2188
0.400	-0.2925	-0.2662	-0.1610	-0.3016	-0.2771
0.450	-0.3141	-0.3053	-0.1541	-0.2926	-0.4012
0.500	-0.3373	-0.3067	-0.1638	-0.2815	-0.6338
0.525	*****	-0.2986	-0.1655	-0.2782	-0.6796
0.550	-0.3663	-0.3010	-0.1710	-0.2700	-0.6797
0.575	*****	-0.2985	-0.1655	-0.2657	-0.6850
0.600	-0.3984	-0.2987	-0.1717	-0.2688	-0.6988
0.625	*****	*****	-0.1617	-0.2930	-0.7527
0.650	-0.4386	-0.3065	-0.1761	-0.3827	-0.8614
0.675	*****	-0.3055	-0.2634	-0.5682	-0.9914
0.700	-0.4824	-0.2855	-0.5187	-0.8114	-1.1192
0.725	*****	-0.3074	*****	-1.0228	-0.8411
0.750	-0.5235	-0.7586	*****	-1.1492	-0.6488
0.775	*****	-1.0373	-1.1601	-1.0733	-0.5922
0.800	-0.5697	-1.1110	-1.1408	-0.8603	*****
0.825	*****	-1.1231	-1.1015	-0.8014	-0.5663
0.850	-0.6219	-1.1108	-0.9983	-0.7979	-0.5560
0.875	*****	-1.0898	-0.8992	-0.7941	-0.5552
0.900	-0.6963	-1.0603	-0.8524	-0.7463	-0.5464
0.925	*****	-1.0371	-0.8043	-0.7397	-0.5197
0.950	-1.0550	-1.0199	-0.7668	-0.7641	-0.4535
0.975	*****	-1.0124	-0.7488	-0.7423	-0.3921
1.000	-0.9907	-1.1076	-0.6683	-0.7819	-0.3866
	$C_{p,l}$	$C_{p,l}$	$C_{p,l}$	$C_{p,l}$	$C_{p,l}$
-0.200	0.2320	0.2266	0.2596	*****	-0.5900
-0.400	0.2317	0.2332	0.2309	0.0625	-0.6594
-0.600	0.2487	0.2386	0.2246	0.0928	-0.6381
-0.700	0.2685	0.2433	0.2271	0.1113	-0.6172
-0.800	0.2892	0.2613	0.2346	0.1328	-0.5521
-0.850	0.2975	0.2773	0.2444	0.1443	-0.5475
-0.900	*****	0.2852	0.2599	0.1651	-0.5183
-0.950	0.2469	0.2590	0.2516	0.1821	-0.1847
-0.975	*****	0.1712	0.1855	0.1480	-0.0486
-1.000	-1.0173	-1.1323	-0.8162	-0.7881	-0.4312

Medium Radius L.E.
 Run No. = 8, Point No. = 161
 $C_N = 0.540$, $C_m = -0.1047$
 $\alpha = 11.4^\circ$, $M_\infty = 0.870$
 $R_{mac} = 6.0 \times 10^6$

Leading Edge Pressures

● starboard
 ○ port

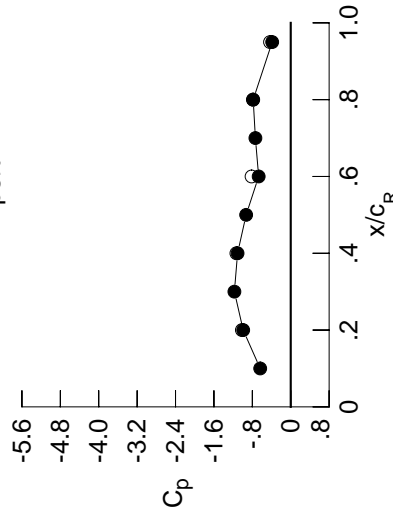

x/c_R	starb'd C_p	port C_p
0.10	-0.6359	*****
0.20	-0.9907	-1.0173
0.30	-1.1737	*****
0.40	-1.1076	-1.1323
0.50	-0.9290	*****
0.60	-0.6683	-0.8162
0.70	-0.7362	*****
0.80	-0.7819	-0.7881
0.90	*****	*****
0.95	-0.3866	-0.4312

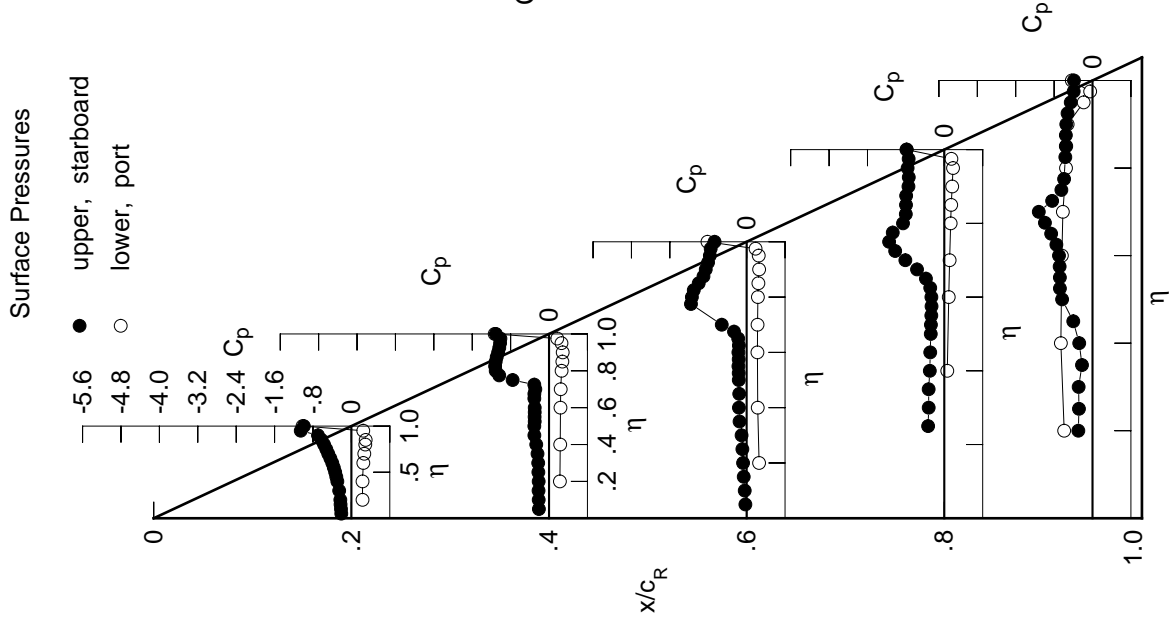
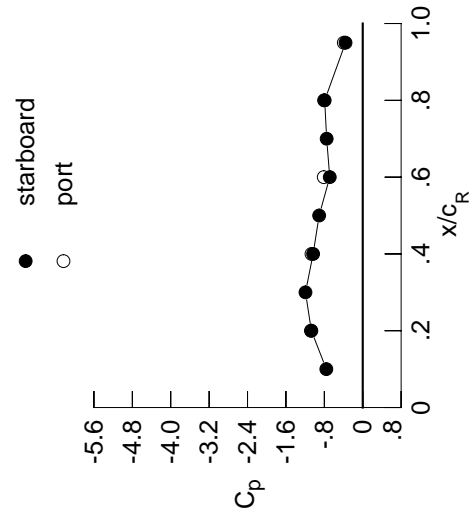

Table F3. Continued.

η	$x/c_R = .2$		$x/c_R = .4$		$x/c_R = .6$		$x/c_R = .8$		$x/c_R = .95$	
	$C_{p,u}$	$C_{p,u}$	$C_{p,u}$	$C_{p,u}$	$C_{p,u}$	$C_{p,u}$	$C_{p,u}$	$C_{p,u}$	$C_{p,u}$	$C_{p,u}$
0.050	-0.2322	-0.2423	-0.0482	*****	*****	*****	*****	*****	*****	*****
0.100	-0.2359	-0.2488	-0.0613	*****	*****	*****	*****	*****	*****	*****
0.150	-0.2481	-0.2492	-0.0795	*****	*****	*****	*****	*****	*****	*****
0.200	-0.2554	-0.2455	-0.0918	*****	*****	*****	*****	*****	*****	*****
0.250	*****	-0.2512	-0.1114	-0.3605	-0.3153	*****	*****	*****	*****	*****
0.300	-0.2847	-0.2642	-0.1500	-0.3553	-0.1960	*****	*****	*****	*****	*****
0.350	*****	-0.2985	-0.1531	-0.3327	-0.2329	*****	*****	*****	*****	*****
0.400	-0.3242	-0.3180	-0.1594	-0.3186	-0.3248	*****	*****	*****	*****	*****
0.450	-0.3466	-0.3036	-0.1599	-0.3097	-0.5310	*****	*****	*****	*****	*****
0.500	-0.3699	-0.3013	-0.1747	-0.2969	-0.6622	*****	*****	*****	*****	*****
0.525	*****	-0.3011	-0.1721	-0.2969	-0.6742	*****	*****	*****	*****	*****
0.550	-0.3980	-0.3086	-0.1768	-0.2960	-0.6825	*****	*****	*****	*****	*****
0.575	*****	-0.3058	-0.1717	-0.3121	-0.7182	*****	*****	*****	*****	*****
0.600	-0.4339	-0.3041	-0.1989	-0.3544	-0.7827	*****	*****	*****	*****	*****
0.625	*****	*****	-0.2429	-0.4558	-0.8926	*****	*****	*****	*****	*****
0.650	-0.4746	-0.2827	-0.4102	-0.6296	-1.0294	*****	*****	*****	*****	*****
0.675	*****	-0.3009	-0.6999	-0.8475	-1.1460	*****	*****	*****	*****	*****
0.700	-0.5155	-0.5905	-0.9790	-1.0466	-0.8160	*****	*****	*****	*****	*****
0.725	*****	-1.0277	*****	-1.1870	-0.6828	*****	*****	*****	*****	*****
0.750	-0.5571	-1.1847	*****	-1.0774	-0.6116	*****	*****	*****	*****	*****
0.775	*****	-1.2105	-1.1922	-0.8970	-0.5778	*****	*****	*****	*****	*****
0.800	-0.6159	-1.2098	-1.1261	-0.8477	*****	*****	*****	*****	*****	*****
0.825	*****	-1.1816	-1.0056	-0.8465	-0.5558	*****	*****	*****	*****	*****
0.850	-0.7707	-1.1428	-0.9199	-0.8518	-0.5346	*****	*****	*****	*****	*****
0.875	*****	-1.0881	-0.8902	-0.8138	-0.5215	*****	*****	*****	*****	*****
0.900	-0.9788	-1.0428	-0.8622	-0.7748	-0.5039	*****	*****	*****	*****	*****
0.925	*****	-1.0132	-0.8132	-0.7727	-0.4727	*****	*****	*****	*****	*****
0.950	-1.1774	-0.9934	-0.7912	-0.7887	-0.4111	*****	*****	*****	*****	*****
0.975	*****	-0.9816	-0.7710	-0.7716	-0.3651	*****	*****	*****	*****	*****
1.000	-1.0704	-1.0337	-0.6870	-0.7925	-0.3586	*****	*****	*****	*****	*****
-0.200	$C_{p,l}$	$C_{p,l}$	$C_{p,l}$	$C_{p,l}$	$C_{p,l}$	$C_{p,l}$	$C_{p,l}$	$C_{p,l}$	$C_{p,l}$	$C_{p,l}$
-0.400	0.2581	0.2470	0.2751	*****	-0.5892	*****	*****	*****	*****	*****
-0.600	0.2612	0.2548	0.2454	0.0762	-0.6532	*****	*****	*****	*****	*****
-0.700	0.2766	0.2597	0.2401	0.1073	-0.6302	*****	*****	*****	*****	*****
-0.800	0.2951	0.2675	0.2446	0.1219	-0.6096	*****	*****	*****	*****	*****
-0.850	0.3131	0.2825	0.2508	0.1466	-0.5413	*****	*****	*****	*****	*****
-0.900	0.3170	0.2971	0.2611	0.1572	-0.5344	*****	*****	*****	*****	*****
-0.950	*****	0.3021	0.2718	0.1774	-0.5010	*****	*****	*****	*****	*****
-0.975	0.2459	0.2622	0.2518	0.1863	-0.1757	*****	*****	*****	*****	*****
-1.000	*****	0.1580	0.1725	0.1378	-0.0475	*****	*****	*****	*****	*****
	-1.0781	-1.0675	-0.8123	-0.8044	-0.3941	*****	*****	*****	*****	*****

Medium Radius L.E.
 Run No. = 8, Point No. = 162
 $C_N = 0.595$, $C_m = -0.1135$
 $\alpha = 12.4^\circ$, $M_\infty = 0.870$
 $R_{mac} = 6.0 \times 10^6$

Leading Edge Pressures



x/c_R	starb'd C_p	port C_p
0.10	-0.7582	*****
0.20	-1.0704	-1.0781
0.30	-1.1927	*****
0.40	-1.0337	-1.0675
0.50	-0.9082	*****
0.60	-0.6870	-0.8123
0.70	-0.7516	*****
0.80	-0.7925	-0.8044
0.90	*****	*****
0.95	-0.3586	-0.3941

Surface Pressures

● upper, starboard
 ○ lower, port

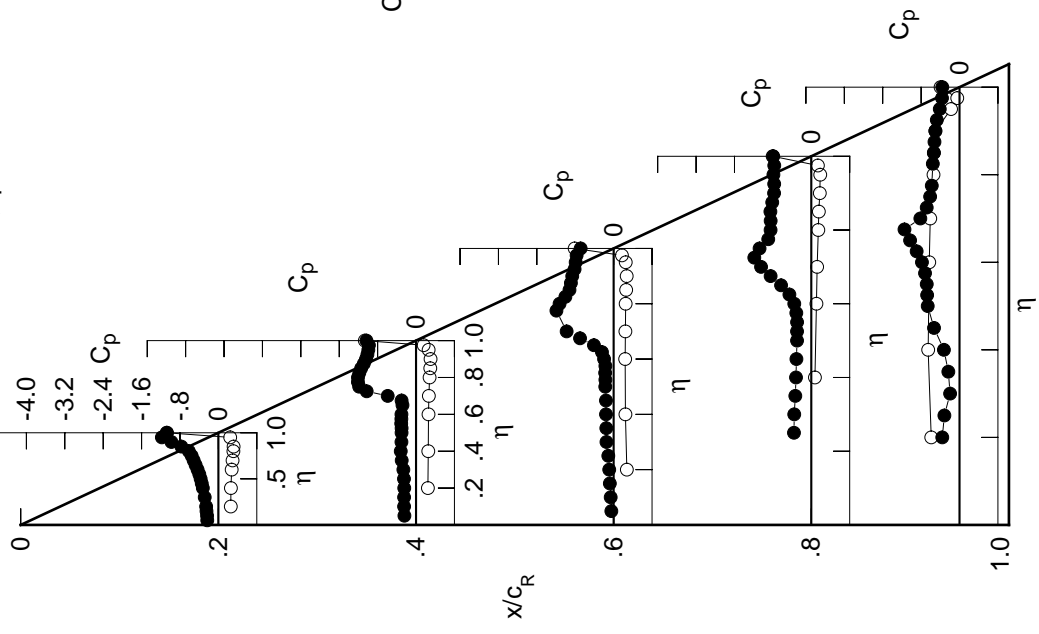

Table F3. Continued.

η	$x/c_R = .2$		$x/c_R = .4$		$x/c_R = .6$		$x/c_R = .8$		$x/c_R = .95$	
	$C_{p,u}$	$C_{p,u}$	$C_{p,u}$	$C_{p,u}$	$C_{p,u}$	$C_{p,u}$	$C_{p,u}$	$C_{p,u}$	$C_{p,u}$	$C_{p,u}$
0.050	-0.2560	-0.2831	-0.0678	*****	*****	*****	*****	*****	*****	*****
0.100	-0.2567	-0.2870	-0.0782	*****	*****	*****	*****	*****	*****	*****
0.150	-0.2730	-0.2890	-0.0944	*****	*****	*****	*****	*****	*****	*****
0.200	-0.2828	-0.2882	-0.1162	*****	*****	*****	*****	*****	*****	*****
0.250	*****	-0.3144	-0.1493	-0.3873	-0.3873	-0.3873	-0.3873	-0.3873	-0.3873	-0.3873
0.300	-0.3132	-0.3298	-0.1491	-0.3646	-0.3646	-0.3646	-0.3646	-0.3646	-0.3646	-0.3646
0.350	*****	-0.3232	-0.1563	-0.3485	-0.3485	-0.3485	-0.3485	-0.3485	-0.3485	-0.3485
0.400	-0.3494	-0.3196	-0.1664	-0.3354	-0.3354	-0.3354	-0.3354	-0.3354	-0.3354	-0.3354
0.450	-0.3650	-0.3274	-0.1641	-0.3210	-0.3210	-0.3210	-0.3210	-0.3210	-0.3210	-0.3210
0.500	-0.3878	-0.3293	-0.1791	-0.3167	-0.3167	-0.3167	-0.3167	-0.3167	-0.3167	-0.3167
0.525	*****	-0.3311	-0.1787	-0.3251	-0.3251	-0.3251	-0.3251	-0.3251	-0.3251	-0.3251
0.550	-0.4166	-0.3331	-0.1934	-0.3440	-0.3440	-0.3440	-0.3440	-0.3440	-0.3440	-0.3440
0.575	*****	-0.3291	-0.2279	-0.3938	-0.3938	-0.3938	-0.3938	-0.3938	-0.3938	-0.3938
0.600	-0.4472	-0.3306	-0.3589	-0.4946	-0.4946	-0.4946	-0.4946	-0.4946	-0.4946	-0.4946
0.625	*****	*****	-0.5478	-0.6562	-0.6562	-0.6562	-0.6562	-0.6562	-0.6562	-0.6562
0.650	-0.4881	-0.5650	-0.8342	-0.8610	-0.8610	-0.8610	-0.8610	-0.8610	-0.8610	-0.8610
0.675	*****	-0.8765	-1.0647	-1.0645	-0.7309	-0.7309	-0.7309	-0.7309	-0.7309	-0.7309
0.700	-0.5090	-1.1217	-1.2093	-1.2187	-0.6690	-0.6690	-0.6690	-0.6690	-0.6690	-0.6690
0.725	*****	-1.1898	*****	-1.1705	-0.6144	-0.6144	-0.6144	-0.6144	-0.6144	-0.6144
0.750	-0.6800	-1.2540	*****	-0.9505	-0.5710	-0.5710	-0.5710	-0.5710	-0.5710	-0.5710
0.775	*****	-1.3052	-1.1364	-0.9120	-0.5470	-0.5470	-0.5470	-0.5470	-0.5470	-0.5470
0.800	-0.9338	-1.2764	-1.0358	-0.9063	*****	*****	*****	*****	*****	*****
0.825	*****	-1.2196	-0.9612	-0.9151	-0.5205	-0.5205	-0.5205	-0.5205	-0.5205	-0.5205
0.850	-1.1050	-1.1567	-0.9289	-0.9155	-0.5012	-0.5012	-0.5012	-0.5012	-0.5012	-0.5012
0.875	*****	-1.0813	-0.9177	-0.8637	-0.4989	-0.4989	-0.4989	-0.4989	-0.4989	-0.4989
0.900	-1.1520	-1.0277	-0.8824	-0.7976	-0.4857	-0.4857	-0.4857	-0.4857	-0.4857	-0.4857
0.925	*****	-0.9980	-0.8389	-0.7918	-0.4480	-0.4480	-0.4480	-0.4480	-0.4480	-0.4480
0.950	-1.1302	-0.9703	-0.8154	-0.8130	-0.3908	-0.3908	-0.3908	-0.3908	-0.3908	-0.3908
0.975	*****	-0.9556	-0.7939	-0.7951	-0.3451	-0.3451	-0.3451	-0.3451	-0.3451	-0.3451
1.000	-1.1299	-0.9881	-0.7108	-0.8104	-0.3321	-0.3321	-0.3321	-0.3321	-0.3321	-0.3321
-0.200	$C_{p,l}$	$C_{p,l}$	$C_{p,l}$	$C_{p,l}$	$C_{p,l}$	$C_{p,l}$	$C_{p,l}$	$C_{p,l}$	$C_{p,l}$	$C_{p,l}$
-0.400	0.2867	0.2703	0.2913	*****	-0.5869	-0.5869	-0.5869	-0.5869	-0.5869	-0.5869
-0.600	0.2891	0.2775	0.2624	0.0902	-0.6445	-0.6445	-0.6445	-0.6445	-0.6445	-0.6445
-0.700	0.3064	0.2825	0.2569	0.1204	-0.6222	-0.6222	-0.6222	-0.6222	-0.6222	-0.6222
-0.800	0.3229	0.2910	0.2604	0.1361	-0.5989	-0.5989	-0.5989	-0.5989	-0.5989	-0.5989
-0.850	0.3372	0.3051	0.2685	0.1614	-0.5311	-0.5311	-0.5311	-0.5311	-0.5311	-0.5311
-0.900	0.3368	0.3160	0.2765	0.1714	-0.5210	-0.5210	-0.5210	-0.5210	-0.5210	-0.5210
-0.950	*****	0.3154	0.2824	0.1886	-0.4834	-0.4834	-0.4834	-0.4834	-0.4834	-0.4834
-0.975	0.2451	0.2629	0.2510	0.1885	-0.1670	-0.1670	-0.1670	-0.1670	-0.1670	-0.1670
-1.000	*****	0.1456	0.1558	0.1251	-0.0464	-0.0464	-0.0464	-0.0464	-0.0464	-0.0464
-1.000	-1.1228	-1.0170	-0.8354	-0.8397	-0.3627	-0.3627	-0.3627	-0.3627	-0.3627	-0.3627

Medium Radius L.E.
 Run No. = 8, Point No. = 163
 $C_N = 0.649$, $C_m = -0.1217$
 $\alpha = 13.4^\circ$, $M_\infty = 0.870$
 $R_{mac} = 6.0 \times 10^6$

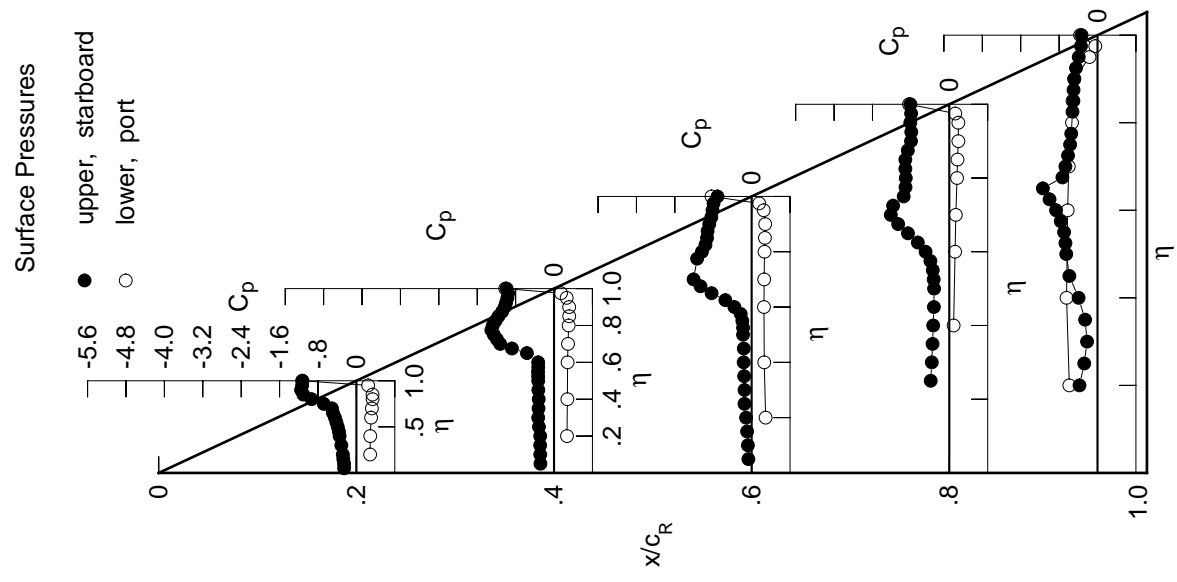
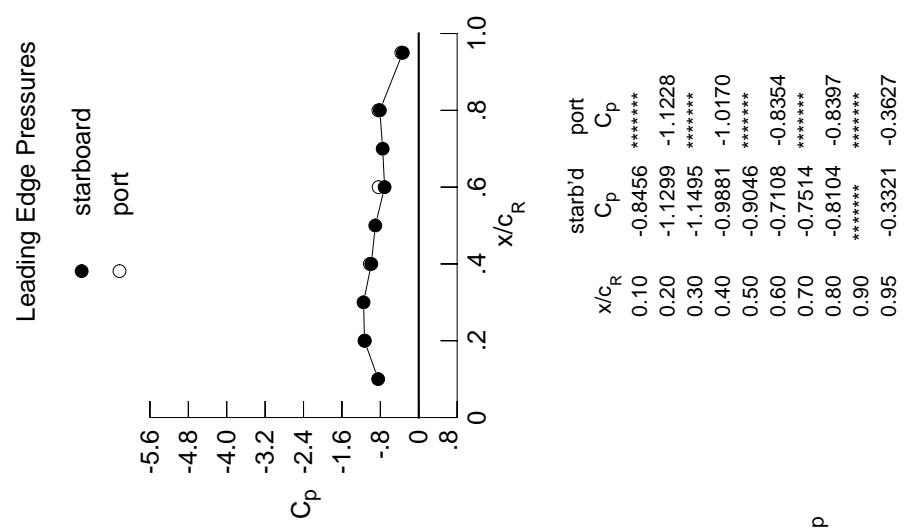
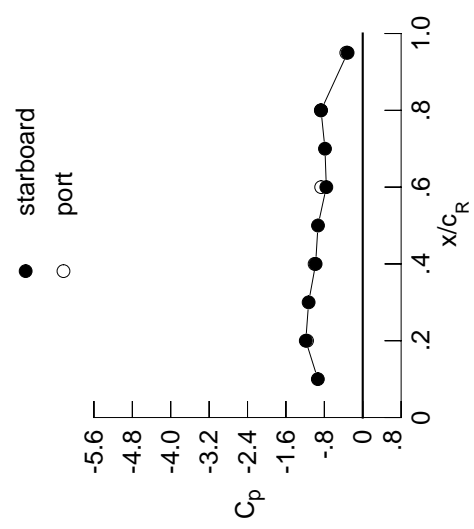

Table F3. Continued.

η	$x/c_R = .2$		$x/c_R = .4$		$x/c_R = .6$		$x/c_R = .8$		$x/c_R = .95$	
	$C_{p,u}$	$C_{p,u}$	$C_{p,u}$	$C_{p,u}$	$C_{p,u}$	$C_{p,u}$	$C_{p,u}$	$C_{p,u}$	$C_{p,u}$	$C_{p,u}$
0.050	-0.2724	-0.3109	-0.0840	*****	*****	*****	*****	*****	*****	*****
0.100	-0.2734	-0.3127	-0.0943	*****	*****	*****	*****	*****	*****	*****
0.150	-0.2942	-0.3152	-0.1138	*****	*****	*****	*****	*****	*****	*****
0.200	-0.3132	-0.3236	-0.1450	*****	*****	*****	*****	*****	*****	-0.4104
0.250	*****	-0.3487	-0.1534	-0.4148	-0.3208	*****	*****	*****	*****	*****
0.300	-0.3358	-0.3361	-0.1610	-0.3899	-0.2892	*****	*****	*****	*****	*****
0.350	*****	-0.3369	-0.1685	-0.3750	-0.3431	*****	*****	*****	*****	*****
0.400	-0.3692	-0.3373	-0.1793	-0.3608	-0.5107	*****	*****	*****	*****	*****
0.450	-0.3793	-0.3456	-0.1806	-0.3562	-0.6450	*****	*****	*****	*****	*****
0.500	-0.4012	-0.3404	-0.2064	-0.3704	-0.6934	*****	*****	*****	*****	*****
0.525	*****	-0.3399	-0.2281	-0.4013	-0.7277	*****	*****	*****	*****	*****
0.550	-0.4295	-0.3437	-0.2868	-0.4561	-0.7871	*****	*****	*****	*****	*****
0.575	*****	-0.3526	-0.3896	-0.5605	-0.8815	*****	*****	*****	*****	*****
0.600	-0.4357	-0.4118	-0.6017	-0.7052	-0.9988	*****	*****	*****	*****	*****
0.625	*****	*****	-0.8209	-0.8842	-1.1285	*****	*****	*****	*****	*****
0.650	-0.4252	-0.9348	-1.0533	-1.0603	-0.7560	*****	*****	*****	*****	*****
0.675	*****	-1.2086	-1.2200	-1.2118	-0.6502	*****	*****	*****	*****	*****
0.700	-0.7430	-1.3516	-1.3284	-1.1043	-0.5944	*****	*****	*****	*****	*****
0.725	*****	-1.3453	*****	-0.9264	-0.5525	*****	*****	*****	*****	*****
0.750	-1.0323	-1.3009	*****	-0.9117	-0.5316	*****	*****	*****	*****	*****
0.775	*****	-1.3436	-1.0165	-0.9091	-0.5192	*****	*****	*****	*****	*****
0.800	-1.1503	-1.3155	-0.9786	-0.9211	*****	*****	*****	*****	*****	*****
0.825	*****	-1.2095	-0.9782	-0.9389	-0.4871	*****	*****	*****	*****	*****
0.850	-1.2003	-1.1282	-0.9883	-0.9317	-0.4741	*****	*****	*****	*****	*****
0.875	*****	-1.0712	-0.9628	-0.8700	-0.4616	*****	*****	*****	*****	*****
0.900	-1.1738	-1.0352	-0.9016	-0.8428	-0.4340	*****	*****	*****	*****	*****
0.925	*****	-1.0039	-0.8863	-0.8543	-0.3977	*****	*****	*****	*****	*****
0.950	-1.1458	-0.9755	-0.8773	-0.8691	-0.3565	*****	*****	*****	*****	*****
0.975	*****	-0.9609	-0.8542	-0.8550	-0.3236	*****	*****	*****	*****	*****
1.000	-1.1865	-0.9813	-0.7585	-0.8684	-0.3152	*****	*****	*****	*****	*****
-0.200	$C_{p,l}$	0.2944	0.3100	*****	-0.5830	*****	*****	*****	*****	*****
-0.400	$C_{p,l}$	0.3171	0.2994	0.2838	0.1053	-0.6372	*****	*****	*****	*****
-0.600	$C_{p,l}$	0.3324	0.3084	0.2758	0.1374	-0.6124	*****	*****	*****	*****
-0.700	$C_{p,l}$	0.3476	0.3128	0.2788	0.1527	-0.5881	*****	*****	*****	*****
-0.800	$C_{p,l}$	0.3570	0.3256	0.2851	0.1740	-0.5172	*****	*****	*****	*****
-0.850	$C_{p,l}$	0.3538	0.3325	0.2925	0.1847	-0.5077	*****	*****	*****	*****
-0.900	$C_{p,l}$	0.3254	0.3254	0.2936	0.1991	-0.4656	*****	*****	*****	*****
-0.950	$C_{p,l}$	0.2407	0.2609	0.2487	0.1889	-0.1577	*****	*****	*****	*****
-0.975	$C_{p,l}$	0.1301	0.1301	0.1400	0.1131	-0.0472	*****	*****	*****	*****
-1.000	$C_{p,l}$	-1.1603	-1.0020	-0.8656	-0.8731	-0.3423	*****	*****	*****	*****

Medium Radius L.E.
 Run No. = 8, Point No. = 164
 $C_N = 0.700$, $C_m = -0.1274$
 $\alpha = 14.5^\circ$, $M_\infty = 0.870$
 $R_{mac} = 6.0 \times 10^6$

Leading Edge Pressures



x/c_R	starb'd C_p	port C_p
0.10	-0.9352	*****
0.20	-1.1865	-1.1603
0.30	-1.1271	*****
0.40	-0.9813	-1.0020
0.50	-0.9323	*****
0.60	-0.7585	-0.8656
0.70	-0.7867	*****
0.80	-0.8684	-0.8731
0.90	*****	*****
0.95	-0.3152	-0.3423

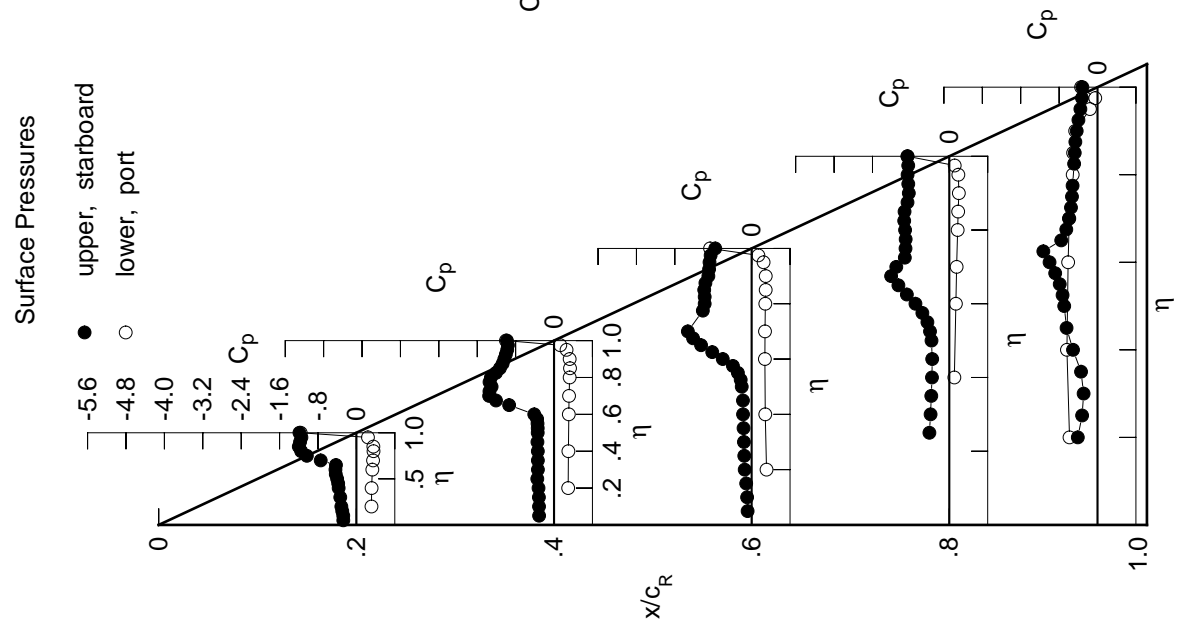
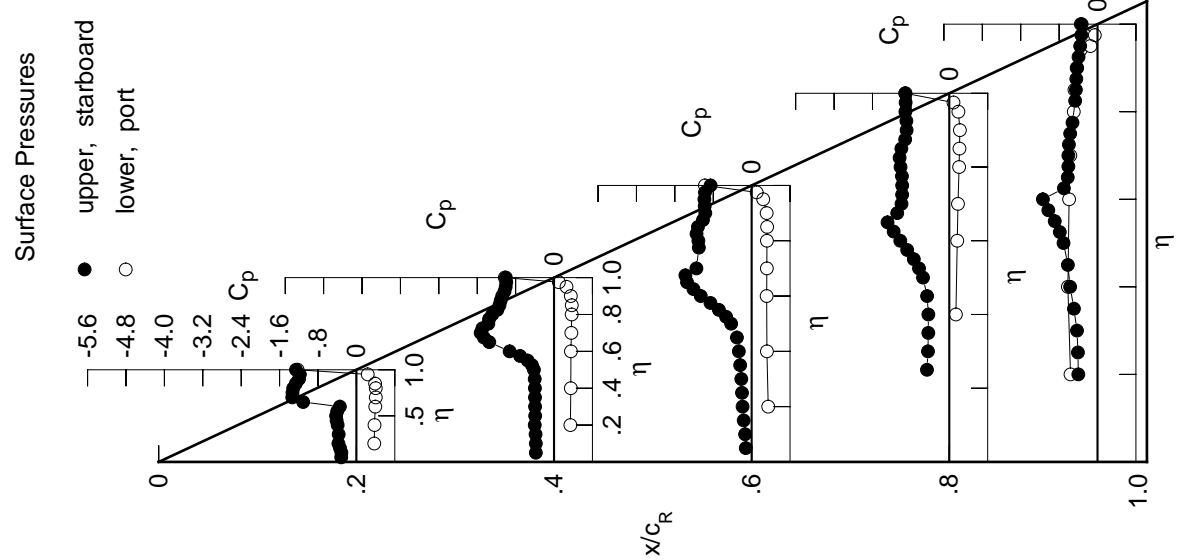
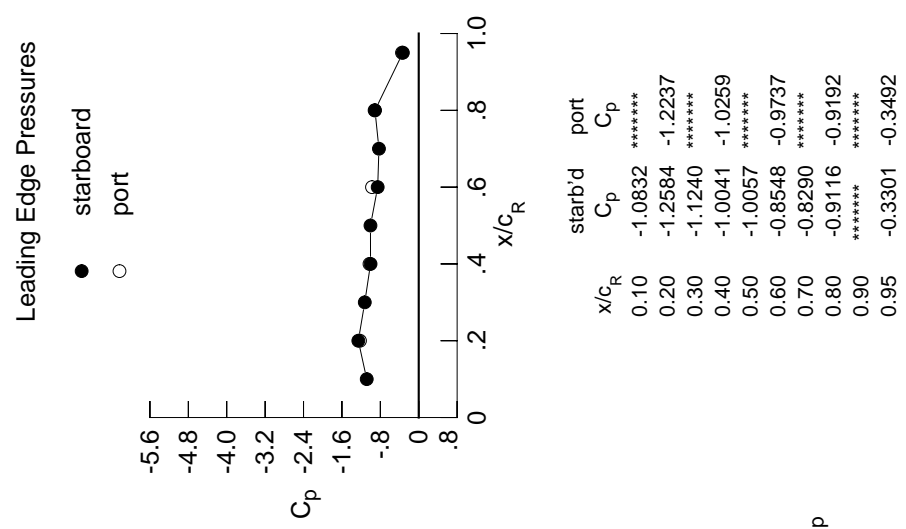

Table F3. Continued.

η	$x/c_R = .2$		$x/c_R = .4$		$x/c_R = .6$		$x/c_R = .8$		$x/c_R = .95$	
	$C_{p,u}$	$C_{p,u}$	$C_{p,u}$	$C_{p,u}$	$C_{p,u}$	$C_{p,u}$	$C_{p,u}$	$C_{p,u}$	$C_{p,u}$	$C_{p,u}$
0.050	-0.3160	-0.3795	-0.1227	*****	*****	*****	*****	*****	*****	*****
0.100	-0.3118	-0.3794	-0.1357	*****	*****	*****	*****	*****	*****	*****
0.150	-0.3405	-0.3846	-0.1652	*****	*****	*****	*****	*****	*****	*****
0.200	-0.3750	-0.4013	-0.1888	*****	*****	*****	*****	*****	*****	-0.4003
0.250	*****	-0.3932	-0.2008	-0.4649	-0.4080	*****	*****	*****	*****	-0.4080
0.300	-0.3692	-0.3952	-0.2154	-0.4443	-0.4274	*****	*****	*****	*****	-0.4274
0.350	*****	-0.3971	-0.2388	-0.4372	-0.4915	*****	*****	*****	*****	-0.4915
0.400	-0.3904	-0.3982	-0.2670	-0.4359	-0.5702	*****	*****	*****	*****	-0.5702
0.450	-0.4120	-0.4022	-0.3061	-0.4625	-0.6174	*****	*****	*****	*****	-0.6174
0.500	-0.4220	-0.4191	-0.4271	-0.5468	-0.7082	*****	*****	*****	*****	-0.7082
0.525	*****	-0.4598	-0.5327	-0.6310	-0.7854	*****	*****	*****	*****	-0.7854
0.550	-0.3996	-0.5486	-0.6823	-0.7392	-0.8914	*****	*****	*****	*****	-0.8914
0.575	*****	-0.7073	-0.8576	-0.8767	-1.0248	*****	*****	*****	*****	-1.0248
0.600	-0.3439	-0.9253	-1.0596	-1.0206	-1.1372	*****	*****	*****	*****	-1.1372
0.625	*****	*****	-1.2113	-1.1596	-0.7011	*****	*****	*****	*****	-0.7011
0.650	-1.1093	-1.3491	-1.3466	-1.2861	-0.6202	*****	*****	*****	*****	-0.6202
0.675	*****	-1.4620	-1.3799	-1.0848	-0.6069	*****	*****	*****	*****	-0.6069
0.700	-1.3363	-1.5288	-1.1505	-0.9950	-0.6069	*****	*****	*****	*****	-0.6069
0.725	*****	-1.4918	*****	-0.9821	-0.5957	*****	*****	*****	*****	-0.5957
0.750	-1.3316	-1.3690	*****	-0.9813	-0.5697	*****	*****	*****	*****	-0.5697
0.775	*****	-1.3532	-1.0997	-0.9867	-0.5209	*****	*****	*****	*****	-0.5209
0.800	-1.3161	-1.2874	-1.1098	-1.0160	*****	*****	*****	*****	*****	*****
0.825	*****	-1.1809	-1.1482	-1.0351	-0.4658	*****	*****	*****	*****	-0.4658
0.850	-1.2620	-1.1364	-1.1194	-0.9983	-0.4504	*****	*****	*****	*****	-0.4504
0.875	*****	-1.1122	-1.0144	-0.9193	-0.4413	*****	*****	*****	*****	-0.4413
0.900	-1.1964	-1.0791	-0.9655	-0.8890	-0.4236	*****	*****	*****	*****	-0.4236
0.925	*****	-1.0319	-0.9786	-0.8936	-0.3956	*****	*****	*****	*****	-0.3956
0.950	-1.1777	-1.0074	-0.9851	-0.9142	-0.3608	*****	*****	*****	*****	-0.3608
0.975	*****	-0.9955	-0.9719	-0.9097	-0.3360	*****	*****	*****	*****	-0.3360
1.000	-1.2584	-1.0041	-0.8548	-0.9116	-0.3301	*****	*****	*****	*****	-0.3301
-0.200	$C_{p,l}$	0.3718	0.3411	0.3456	*****	*****	*****	*****	*****	-0.5626
-0.400	$C_{p,l}$	0.3776	0.3492	0.3180	0.1376	0.6172	*****	*****	*****	-0.6172
-0.600	$C_{p,l}$	0.3936	0.3523	0.3132	0.1661	0.5917	*****	*****	*****	-0.5917
-0.700	$C_{p,l}$	0.4044	0.3605	0.3167	0.1811	0.5667	*****	*****	*****	-0.5667
-0.800	$C_{p,l}$	0.4032	0.3684	0.3186	0.2045	0.4942	*****	*****	*****	-0.4942
-0.850	$C_{p,l}$	0.3893	0.3696	0.3223	0.2123	0.4802	*****	*****	*****	-0.4802
-0.900	$C_{p,l}$	*****	0.3493	0.3131	0.2207	0.4346	*****	*****	*****	-0.4346
-0.950	$C_{p,l}$	0.2360	0.2600	0.2411	0.1895	-0.1461	*****	*****	*****	-0.1461
-0.975	$C_{p,l}$	*****	0.1010	0.1046	0.0876	-0.0565	*****	*****	*****	-0.0565
-1.000	$C_{p,l}$	-1.2237	-1.0259	-0.9737	-0.9192	-0.3492	*****	*****	*****	-0.3492

Medium Radius L.E.
 Run No. = 8, Point No. = 165
 $C_N = 0.816$, $C_m = -0.1500$
 $\alpha = 16.5^\circ$, $M_\infty = 0.869$
 $R_{mac} = 6.0 \times 10^6$



x/c_R	starb'd C_p	port C_p
0.10	-1.0832	*****
0.20	-1.2584	-1.2237
0.30	-1.1240	*****
0.40	-1.0041	-1.0259
0.50	-1.0057	*****
0.60	-0.8548	-0.9737
0.70	-0.8290	*****
0.80	-0.9116	-0.9192
0.90	*****	*****
0.95	-0.3301	-0.3492

Table F3. Continued.

η	$x/c_R = 0.2$		$x/c_R = 0.4$		$x/c_R = 0.6$		$x/c_R = 0.8$		$x/c_R = 0.95$	
	$C_{p,u}$	$C_{p,l}$	$C_{p,u}$	$C_{p,l}$	$C_{p,u}$	$C_{p,l}$	$C_{p,u}$	$C_{p,l}$	$C_{p,u}$	$C_{p,l}$
0.050	-0.3722	-0.4354	-0.3035	*****	*****	*****	*****	*****	*****	*****
0.100	-0.3684	-0.4342	-0.3278	*****	*****	*****	*****	*****	*****	*****
0.150	-0.4114	-0.4573	-0.3569	*****	*****	*****	*****	*****	*****	*****
0.200	-0.4182	-0.4463	-0.3656	*****	*****	*****	*****	*****	*****	-0.2715
0.250	*****	-0.4481	-0.3932	-0.4996	-0.4996	-0.3541	*****	*****	*****	*****
0.300	-0.4086	-0.4524	-0.4276	-0.4795	-0.3899	*****	*****	*****	*****	*****
0.350	*****	-0.4587	-0.4604	-0.4842	-0.4414	*****	*****	*****	*****	*****
0.400	-0.4387	-0.4711	-0.5140	-0.5101	-0.5128	*****	*****	*****	*****	*****
0.450	-0.4474	-0.5123	-0.6018	-0.5933	-0.5990	*****	*****	*****	*****	*****
0.500	-0.4318	-0.6290	-0.7927	-0.7663	-0.7482	*****	*****	*****	*****	*****
0.525	*****	-0.7573	-0.9198	-0.8870	-0.8497	*****	*****	*****	*****	*****
0.550	-0.4856	-0.9229	-1.0637	-1.0170	-0.9713	*****	*****	*****	*****	*****
0.575	*****	-1.1086	-1.1995	-1.1459	-1.0852	*****	*****	*****	*****	*****
0.600	-1.1315	-1.2728	-1.3327	-1.2603	-0.9247	*****	*****	*****	*****	*****
0.625	*****	*****	-1.4238	-1.3574	-0.7480	*****	*****	*****	*****	*****
0.650	-1.4986	-1.5228	-1.2401	-1.2766	-0.7550	*****	*****	*****	*****	*****
0.675	*****	-1.5450	-1.1847	-1.0988	-0.7511	*****	*****	*****	*****	*****
0.700	-1.4748	-1.4163	-1.1871	-1.0954	-0.7556	*****	*****	*****	*****	*****
0.725	*****	-1.3681	*****	-1.1011	-0.7583	*****	*****	*****	*****	*****
0.750	-1.4416	-1.3646	*****	-1.1049	-0.7273	*****	*****	*****	*****	*****
0.775	*****	-1.3694	-1.2284	-1.0994	-0.6381	*****	*****	*****	*****	*****
0.800	-1.3829	-1.3652	-1.2543	-1.0883	*****	*****	*****	*****	*****	*****
0.825	*****	-1.3237	-1.2233	-1.0617	-0.5265	*****	*****	*****	*****	*****
0.850	-1.2869	-1.2503	-1.1640	-1.0356	-0.4981	*****	*****	*****	*****	*****
0.875	*****	-1.1670	-1.1321	-0.9794	-0.5062	*****	*****	*****	*****	*****
0.900	-1.2212	-1.1049	-1.1256	-0.9383	-0.5007	*****	*****	*****	*****	*****
0.925	*****	-1.0799	-1.1273	-0.9253	-0.4917	*****	*****	*****	*****	*****
0.950	-1.1894	-1.0733	-1.1224	-0.9410	-0.4320	*****	*****	*****	*****	*****
0.975	*****	-1.0666	-1.1069	-0.9360	-0.4041	*****	*****	*****	*****	*****
1.000	-1.2633	-1.0733	-0.9762	-0.9334	-0.3949	*****	*****	*****	*****	*****
-0.200	$C_{p,l}$	0.3838	0.3806	*****	-0.5436	*****	*****	*****	*****	*****
-0.400	0.4336	0.3939	0.3520	0.1669	-0.5960	*****	*****	*****	*****	*****
-0.600	0.4460	0.3964	0.3473	0.1956	-0.5715	*****	*****	*****	*****	*****
-0.700	0.4528	0.4017	0.3475	0.2086	-0.5472	*****	*****	*****	*****	*****
-0.800	0.4415	0.4044	0.3496	0.2287	-0.4732	*****	*****	*****	*****	*****
-0.850	0.4197	0.3983	0.3482	0.2359	-0.4563	*****	*****	*****	*****	*****
-0.900	*****	0.3658	0.3278	0.2378	-0.4085	*****	*****	*****	*****	*****
-0.950	0.2278	0.2503	0.2307	0.1848	-0.1423	*****	*****	*****	*****	*****
-0.975	*****	0.0660	0.0671	0.0583	-0.0782	*****	*****	*****	*****	*****
-1.000	-1.2590	-1.0816	-1.1216	-0.9487	-0.4030	*****	*****	*****	*****	*****

Medium Radius L.E.
 Run No. = 8, Point No. = 166
 $C_N = 0.943$, $C_m = -0.1818$
 $\alpha = 18.6^\circ$, $M_\infty = 0.870$
 $R_{mac} = 6.0 \times 10^6$

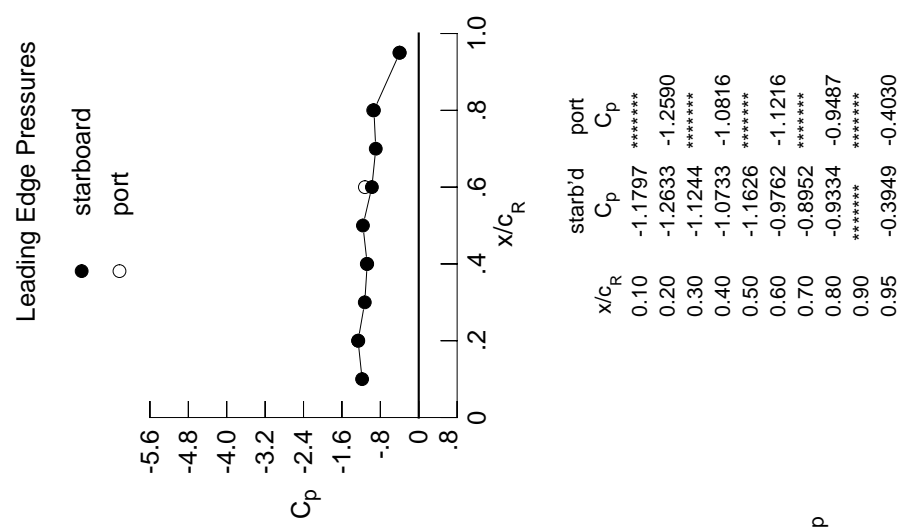

x/c_R	starb'd C_p	port C_p
0.10	-1.1797	*****
0.20	-1.2633	-1.2590
0.30	-1.1244	*****
0.40	-1.0733	-1.0816
0.50	-1.1626	*****
0.60	-0.9762	-1.1216
0.70	-0.8952	*****
0.80	-0.9334	-0.9487
0.90	*****	*****
0.95	-0.3949	-0.4030

Table F3. Continued.

η	$x/c_R = .2$		$x/c_R = .4$		$x/c_R = .6$		$x/c_R = .8$		$x/c_R = .95$	
	$C_{p,u}$	$C_{p,u}$	$C_{p,u}$	$C_{p,u}$	$C_{p,u}$	$C_{p,u}$	$C_{p,u}$	$C_{p,u}$	$C_{p,u}$	$C_{p,u}$
0.050	-0.4357	-0.5117	-0.5127	*****	*****	*****	*****	*****	*****	*****
0.100	-0.4452	-0.5147	-0.5161	*****	*****	*****	*****	*****	*****	*****
0.150	-0.4730	-0.5365	-0.5189	*****	*****	*****	*****	*****	*****	*****
0.200	-0.4629	-0.5240	-0.5307	*****	*****	*****	*****	*****	*****	-0.2599
0.250	*****	-0.5333	-0.5383	-0.4945	-0.4945	-0.4945	-0.4945	-0.4945	-0.4945	-0.3721
0.300	-0.4644	-0.5427	-0.5588	-0.5086	-0.5086	-0.5086	-0.5086	-0.5086	-0.5086	-0.4421
0.350	*****	-0.5606	-0.6014	-0.5475	-0.5475	-0.5475	-0.5475	-0.5475	-0.5475	-0.5063
0.400	-0.4943	-0.6081	-0.6894	-0.6161	-0.6161	-0.6161	-0.6161	-0.6161	-0.6161	-0.5949
0.450	-0.5076	-0.7212	-0.8467	-0.7487	-0.7487	-0.7487	-0.7487	-0.7487	-0.7487	-0.7195
0.500	-0.6021	-0.9313	-1.0777	-0.9484	-0.9484	-0.9484	-0.9484	-0.9484	-0.9484	-0.9166
0.525	*****	-1.0748	-1.1951	-1.0644	-1.0644	-1.0644	-1.0644	-1.0644	-1.0644	-1.0192
0.550	-1.0430	-1.2206	-1.3067	-1.1747	-1.1747	-1.1747	-1.1747	-1.1747	-1.1747	-1.1282
0.575	*****	-1.3472	-1.3981	-1.2816	-1.2816	-1.2816	-1.2816	-1.2816	-1.2816	-1.0393
0.600	-1.4935	-1.4493	-1.4876	-1.3732	-1.3732	-1.3732	-1.3732	-1.3732	-1.3732	-0.7771
0.625	*****	*****	-1.4689	-1.4481	-1.4481	-1.4481	-1.4481	-1.4481	-1.4481	-0.7734
0.650	-1.6103	-1.3940	-1.3037	-1.2251	-1.2251	-1.2251	-1.2251	-1.2251	-1.2251	-0.8031
0.675	*****	-1.3285	-1.2886	-1.1658	-1.1658	-1.1658	-1.1658	-1.1658	-1.1658	-0.7725
0.700	-1.5988	-1.3207	-1.2828	-1.1542	-1.1542	-1.1542	-1.1542	-1.1542	-1.1542	-0.7354
0.725	*****	-1.3219	*****	-1.1478	-1.1478	-1.1478	-1.1478	-1.1478	-1.1478	-0.6664
0.750	-1.5044	-1.3380	*****	-1.1454	-1.1454	-1.1454	-1.1454	-1.1454	-1.1454	-0.5832
0.775	*****	-1.3805	-1.2958	-1.1373	-1.1373	-1.1373	-1.1373	-1.1373	-1.1373	-0.5314
0.800	-1.4135	-1.4029	-1.3132	-1.1455	-1.1455	-1.1455	-1.1455	-1.1455	-1.1455	*****
0.825	*****	-1.3254	-1.2953	-1.1538	-1.1538	-1.1538	-1.1538	-1.1538	-1.1538	-0.5418
0.850	-1.3033	-1.2397	-1.2422	-1.1407	-1.1407	-1.1407	-1.1407	-1.1407	-1.1407	-0.5443
0.875	*****	-1.2063	-1.1973	-1.0629	-1.0629	-1.0629	-1.0629	-1.0629	-1.0629	-0.5572
0.900	-1.2437	-1.2099	-1.1860	-0.9635	-0.9635	-0.9635	-0.9635	-0.9635	-0.9635	-0.5530
0.925	*****	-1.2166	-1.1856	-0.9185	-0.9185	-0.9185	-0.9185	-0.9185	-0.9185	-0.5566
0.950	-1.2066	-1.2127	-1.1886	-0.9249	-0.9249	-0.9249	-0.9249	-0.9249	-0.9249	-0.4901
0.975	*****	-1.2081	-1.1755	-0.9213	-0.9213	-0.9213	-0.9213	-0.9213	-0.9213	-0.4461
1.000	-1.2516	-1.2293	-1.0379	-0.9109	-0.9109	-0.9109	-0.9109	-0.9109	-0.9109	-0.4319
	$C_{p,l}$	$C_{p,l}$	$C_{p,l}$	$C_{p,l}$	$C_{p,l}$	$C_{p,l}$	$C_{p,l}$	$C_{p,l}$	$C_{p,l}$	$C_{p,l}$
-0.200	0.4851	0.4364	0.4164	*****	*****	*****	*****	*****	*****	-0.5213
-0.400	0.4910	0.4386	0.3920	0.2015	0.2015	0.2015	0.2015	0.2015	0.2015	-0.5749
-0.600	0.4998	0.4417	0.3826	0.2289	0.2289	0.2289	0.2289	0.2289	0.2289	-0.5494
-0.700	0.5021	0.4450	0.3835	0.2410	0.2410	0.2410	0.2410	0.2410	0.2410	-0.5207
-0.800	0.4779	0.4413	0.3821	0.2565	0.2565	0.2565	0.2565	0.2565	0.2565	-0.4477
-0.850	0.4477	0.4262	0.3748	0.2622	0.2622	0.2622	0.2622	0.2622	0.2622	-0.4304
-0.900	*****	0.3800	0.3431	0.2551	0.2551	0.2551	0.2551	0.2551	0.2551	-0.3831
-0.950	0.2179	0.2396	0.2225	0.1797	0.1797	0.1797	0.1797	0.1797	0.1797	-0.1379
-0.975	*****	0.0297	0.0358	0.0336	0.0336	0.0336	0.0336	0.0336	0.0336	-0.0971
-1.000	-1.2810	-1.2355	-1.1921	-0.9116	-0.9116	-0.9116	-0.9116	-0.9116	-0.9116	-0.4617

Medium Radius L.E.
 Run No. = 8, Point No. = 167
 $C_N = 1.052$, $C_m = -0.2035$
 $\alpha = 20.6^\circ$, $M_\infty = 0.870$
 $R_{mac} = 6.0 \times 10^6$

Leading Edge Pressures
 ● starboard
 ○ port

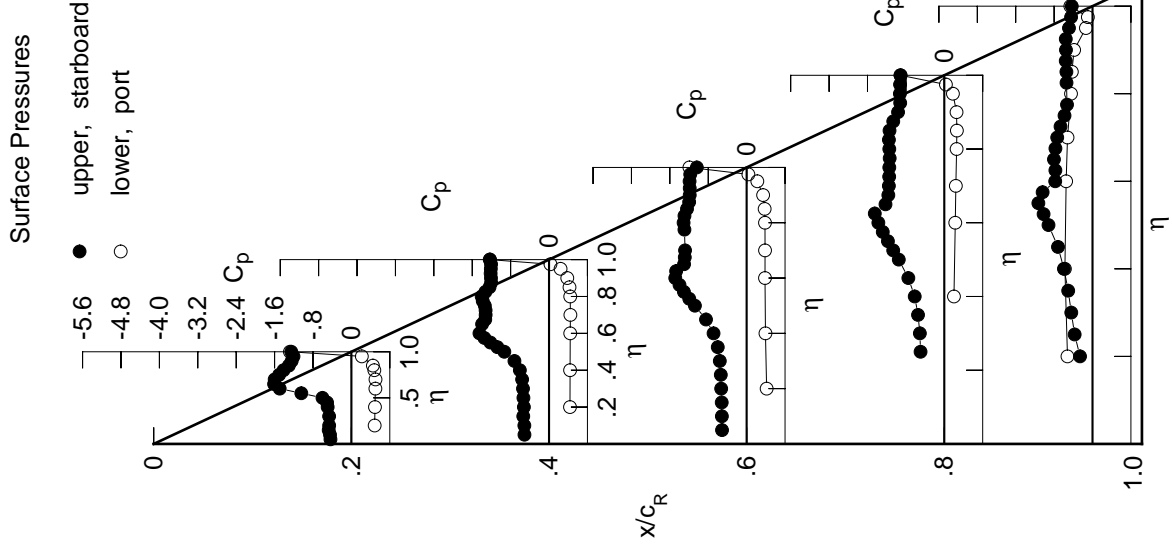
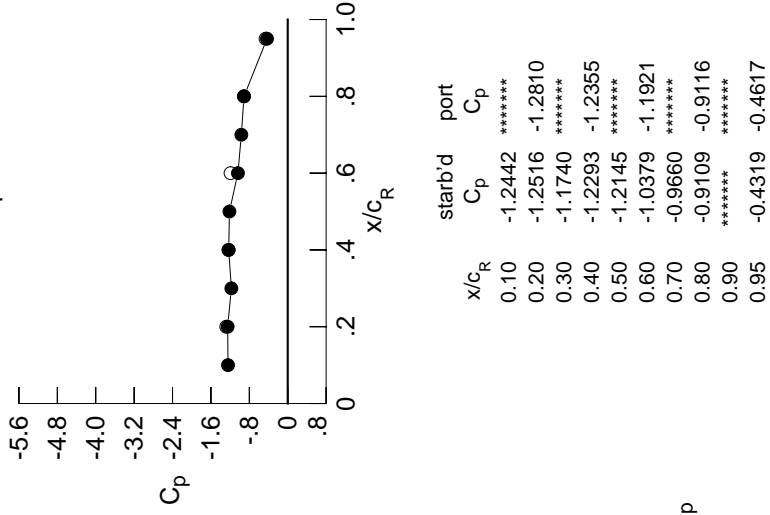

x/c_R	starb'd C_p	port C_p
0.10	-1.2442	*****
0.20	-1.2516	-1.2810
0.30	-1.1740	*****
0.40	-1.2293	-1.2355
0.50	-1.2145	*****
0.60	-1.0379	-1.1921
0.70	-0.9660	*****
0.80	-0.9109	-0.9116
0.90	*****	*****
0.95	-0.4319	-0.4617

Table F3. Continued.

η	$x/c_R = .2$		$x/c_R = .4$		$x/c_R = .6$		$x/c_R = .8$		$x/c_R = .95$	
	$C_{p,u}$	$C_{p,u}$	$C_{p,u}$	$C_{p,u}$	$C_{p,u}$	$C_{p,u}$	$C_{p,u}$	$C_{p,u}$	$C_{p,u}$	$C_{p,u}$
0.050	-0.5025	-0.5888	-0.5753	*****	*****	*****	*****	*****	*****	*****
0.100	-0.5156	-0.5918	-0.5777	*****	*****	*****	*****	*****	*****	*****
0.150	-0.5396	-0.5946	-0.5846	*****	*****	*****	*****	*****	*****	*****
0.200	-0.5303	-0.6184	-0.5938	*****	*****	*****	*****	*****	*****	-0.3043
0.250	*****	-0.6233	-0.6082	-0.5203	-0.5508	-0.5504	*****	*****	*****	-0.4577
0.300	-0.5387	-0.6509	-0.6449	-0.5508	-0.5508	-0.5504	*****	*****	*****	-0.5504
0.350	*****	-0.7022	-0.7165	-0.6237	-0.6200	*****	*****	*****	*****	-0.6200
0.400	-0.5886	-0.7972	-0.8471	-0.7399	-0.7282	*****	*****	*****	*****	-0.7282
0.450	-0.6873	-0.9603	-1.0406	-0.9071	-0.8720	*****	*****	*****	*****	-0.8720
0.500	-0.9803	-1.1686	-1.2626	-1.1094	-1.0654	*****	*****	*****	*****	-1.0654
0.525	*****	-1.2818	-1.3587	-1.2119	-1.0576	*****	*****	*****	*****	-1.0576
0.550	-1.3721	-1.3843	-1.4473	-1.3026	-0.6911	*****	*****	*****	*****	-0.6911
0.575	*****	-1.4698	-1.5168	-1.3853	-0.6618	*****	*****	*****	*****	-0.6618
0.600	-1.6131	-1.5115	-1.5736	-1.4540	-0.6636	*****	*****	*****	*****	-0.6636
0.625	*****	*****	-1.4147	-1.2874	-0.6576	*****	*****	*****	*****	-0.6576
0.650	-1.6233	-1.3386	-1.3628	-1.1403	-0.6273	*****	*****	*****	*****	-0.6273
0.675	*****	-1.3385	-1.3594	-1.1240	-0.5845	*****	*****	*****	*****	-0.5845
0.700	-1.6224	-1.3412	-1.3607	-1.1282	-0.5720	*****	*****	*****	*****	-0.5720
0.725	*****	-1.3460	*****	-1.1191	-0.5714	*****	*****	*****	*****	-0.5714
0.750	-1.6304	-1.3636	*****	-1.1152	-0.5936	*****	*****	*****	*****	-0.5936
0.775	*****	-1.3824	-1.3986	-1.1050	-0.6200	*****	*****	*****	*****	-0.6200
0.800	-1.3993	-1.3587	-1.4088	-1.1308	*****	*****	*****	*****	*****	*****
0.825	*****	-1.3169	-1.3936	-1.1946	-0.6535	*****	*****	*****	*****	-0.6535
0.850	-1.2994	-1.3001	-1.3345	-1.1959	-0.6420	*****	*****	*****	*****	-0.6420
0.875	*****	-1.3001	-1.2679	-1.0498	-0.6573	*****	*****	*****	*****	-0.6573
0.900	-1.2678	-1.3013	-1.2377	-0.9183	-0.6623	*****	*****	*****	*****	-0.6623
0.925	*****	-1.3043	-1.2347	-0.8764	-0.7203	*****	*****	*****	*****	-0.7203
0.950	-1.2484	-1.2936	-1.2396	-0.8939	-0.6265	*****	*****	*****	*****	-0.6265
0.975	*****	-1.2868	-1.2307	-0.8870	-0.6123	*****	*****	*****	*****	-0.6123
1.000	-1.2884	-1.3097	-1.0825	-0.8542	-0.6084	*****	*****	*****	*****	-0.6084
-0.200	$C_{p,l}$	$C_{p,l}$	$C_{p,l}$	$C_{p,l}$	$C_{p,l}$	$C_{p,l}$	$C_{p,l}$	$C_{p,l}$	$C_{p,l}$	$C_{p,l}$
-0.400	0.5424	0.4835	0.4570	*****	*****	*****	*****	*****	*****	-0.4930
-0.600	0.5468	0.4887	0.4325	0.2372	0.5478	*****	*****	*****	*****	-0.5478
-0.700	0.5520	0.4889	0.4213	0.2614	-0.5216	*****	*****	*****	*****	-0.5216
-0.800	0.5463	0.4879	0.4204	0.2708	-0.4940	*****	*****	*****	*****	-0.4940
-0.850	0.5112	0.4750	0.4127	0.2846	-0.4164	*****	*****	*****	*****	-0.4164
-0.900	0.4701	0.4525	0.3997	0.2847	-0.4040	*****	*****	*****	*****	-0.4040
-0.950	0.2063	0.2279	0.2129	0.1742	-0.1390	*****	*****	*****	*****	-0.1390
-0.975	*****	-0.0051	0.0062	0.0094	-0.1261	*****	*****	*****	*****	-0.1261
-1.000	-1.3194	-1.3363	-1.2604	-0.8685	-0.5946	*****	*****	*****	*****	-0.5946

Medium Radius L.E.
 Run No. = 8, Point No. = 168
 $C_N = 1.142$, $C_m = -0.2131$
 $\alpha = 22.6^\circ$, $M_\infty = 0.870$
 $R_{mac} = 6.0 \times 10^6$

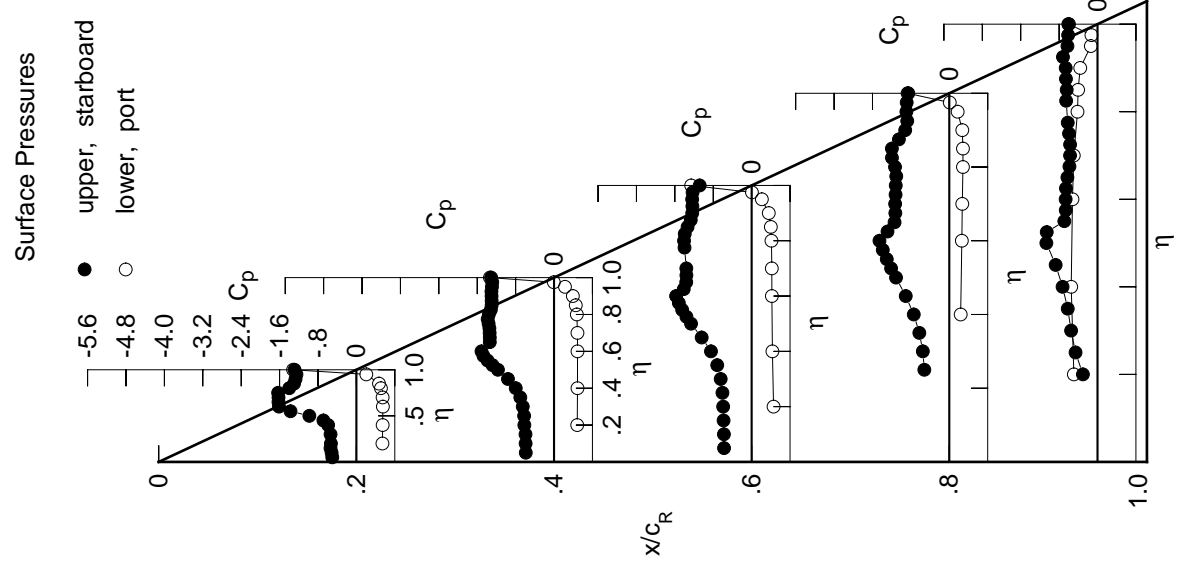
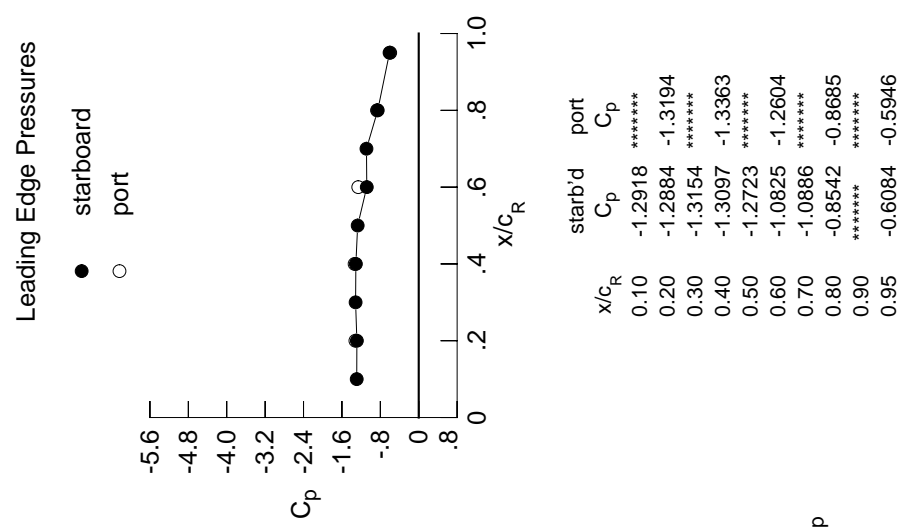

Table F3. Continued.

η	x/c_R .2	x/c_R .4	x/c_R .6	x/c_R .8	x/c_R .95
	$C_{p,u}$	$C_{p,u}$	$C_{p,u}$	$C_{p,u}$	$C_{p,u}$
0.050	-0.5786	-0.6418	0.0109	*****	*****
0.100	-0.5795	-0.6497	0.0018	*****	*****
0.150	-0.6034	-0.6561	-0.0143	*****	*****
0.200	-0.6226	-0.6656	-0.0363	*****	-0.6178
0.250	*****	-0.6971	-0.0753	-0.9193	-0.6967
0.300	-0.6483	-0.7455	-0.1467	-0.9498	-0.7796
0.350	*****	-0.8263	-0.2687	-0.9940	-0.8460
0.400	-0.7808	-0.9610	-0.4679	-1.0135	-0.8867
0.450	-0.9890	-1.1431	-0.7156	-0.9964	-0.8308
0.500	-1.2897	-1.3279	-0.9990	-0.9412	-0.7492
0.525	*****	-1.4132	-1.1232	-0.9163	-0.7490
0.550	-1.5296	-1.4905	-1.2181	-0.8926	-0.7378
0.575	*****	-1.5520	-1.2686	-0.9031	-0.7522
0.600	-1.6515	-1.5428	-1.2625	-0.9214	-0.7574
0.625	*****	*****	-1.1739	-0.9219	-0.7643
0.650	-1.6043	-1.4045	-1.0563	-0.9219	-0.7690
0.675	*****	-1.4002	-0.9832	-0.9213	-0.7536
0.700	-1.6009	-1.4019	-0.9497	-0.9236	-0.7597
0.725	*****	-1.4007	*****	-0.9216	-0.7513
0.750	-1.5832	-1.4119	*****	-0.8982	-0.7437
0.775	*****	-1.4349	-0.8856	-0.8826	-0.7239
0.800	-1.4041	-1.4275	-0.8688	-0.8620	*****
0.825	*****	-1.3777	-0.8614	-0.8543	-0.6844
0.850	-1.3285	-1.3428	-0.8469	-0.8385	-0.6655
0.875	*****	-1.3321	-0.8196	-0.8265	-0.6454
0.900	-1.3124	-1.3362	-0.7888	-0.8127	-0.6242
0.925	*****	-1.3403	-0.7696	-0.7906	-0.6083
0.950	-1.2986	-1.3341	-0.7583	-0.7749	-0.5713
0.975	*****	-1.3257	-0.7484	-0.7413	-0.5265
1.000	-1.3470	-1.3546	-0.6571	-0.7196	-0.4974
	$C_{p,l}$	$C_{p,l}$	$C_{p,l}$	$C_{p,l}$	$C_{p,l}$
-0.200	0.5945	0.5284	0.4923	*****	-0.4951
-0.400	0.6002	0.5305	0.4683	0.2600	-0.5470
-0.600	0.6007	0.5311	0.4555	0.2845	-0.5199
-0.700	0.5877	0.5267	0.4548	0.2918	-0.4921
-0.800	0.5419	0.5070	0.4463	0.3024	-0.4199
-0.850	0.4918	0.4769	0.4308	0.3033	-0.4060
-0.900	*****	0.4031	0.3818	0.2852	-0.3617
-0.950	0.1928	0.2197	0.2277	0.1869	-0.1471
-0.975	*****	-0.0325	0.0171	0.0208	-0.1420
-1.000	-1.3696	-1.3729	-0.7649	-0.7140	-0.5109

x/c_R	starb'd	port
0.10	C_p	C_p
0.20	-1.3282	*****
0.30	-1.3470	-1.3696
0.40	-1.3763	*****
0.50	-1.3546	-1.3729
0.60	-1.2755	*****
0.70	-0.6571	-0.7649
0.80	-0.7259	*****
0.90	-0.7196	-0.7140
0.95	*****	*****
	C_p	C_p
	-1.3474	-0.5109

Medium Radius L.E.

Run No. = 8, Point No. = 169

$C_N = 1.111$, $C_m = -0.1898$

$\alpha = 24.6^\circ$, $M_\infty = 0.870$

$R_{mac} = 6.0 \times 10^6$

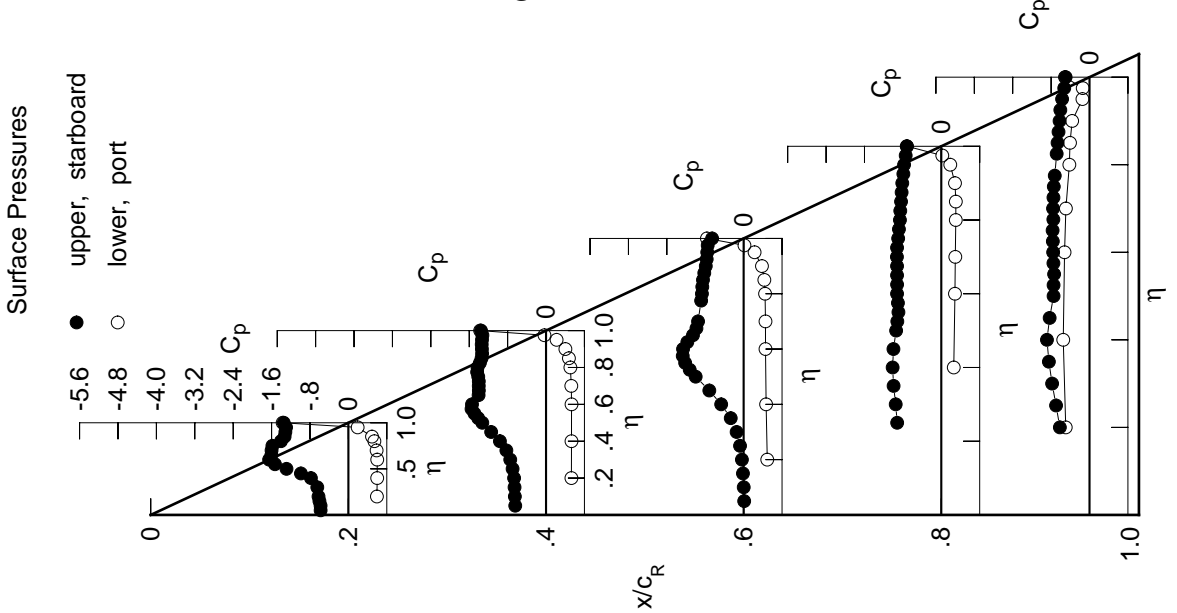

Leading Edge Pressures

● starboard
○ port

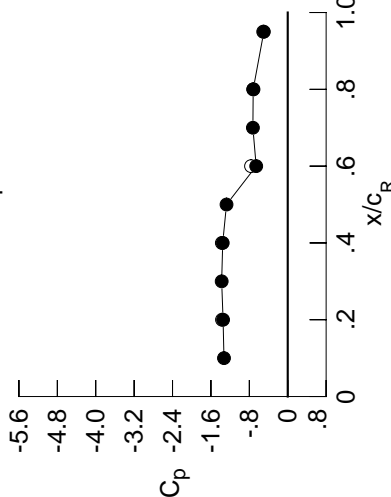
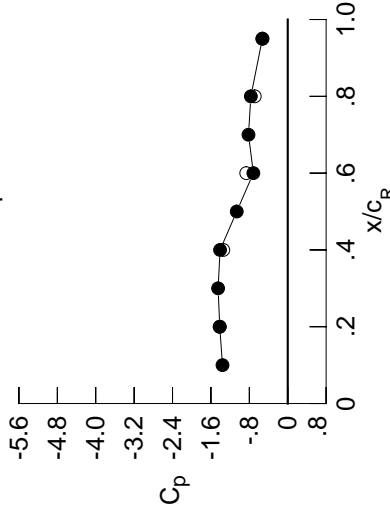

Table F3. Concluded.

η	x/c_R .2	x/c_R .4	x/c_R .6	x/c_R .8	x/c_R .95
	$C_{p,u}$	$C_{p,u}$	$C_{p,u}$	$C_{p,u}$	$C_{p,u}$
0.050	-0.6591	-0.6981	-0.2805	*****	*****
0.100	-0.6643	-0.7067	-0.2747	*****	*****
0.150	-0.6831	-0.7228	-0.2613	*****	*****
0.200	-0.6890	-0.7380	-0.2632	*****	-0.7274
0.250	*****	-0.7857	-0.2854	-0.9735	-0.8215
0.300	-0.7511	-0.8532	-0.3447	-0.9678	-0.8846
0.350	*****	-0.9594	-0.4509	-0.9591	-0.8877
0.400	-1.0115	-1.1073	-0.6279	-0.9183	-0.8302
0.450	-1.2484	-1.2792	-0.8215	-0.8890	-0.7575
0.500	-1.4762	-1.4331	-1.0453	-0.8862	-0.7337
0.525	*****	-1.4979	-1.1375	-0.9001	-0.7494
0.550	-1.6251	-1.5547	-1.1922	-0.9101	-0.7570
0.575	*****	-1.6034	-1.2047	-0.9306	-0.7765
0.600	-1.5992	-1.5544	-1.1514	-0.9455	-0.7810
0.625	*****	*****	-1.0278	-0.9378	-0.7857
0.650	-1.5680	-1.4541	-0.9576	-0.9376	-0.7855
0.675	*****	-1.4547	-0.9505	-0.9386	-0.7725
0.700	-1.5839	-1.4493	-0.9490	-0.9363	-0.7728
0.725	*****	-1.4537	*****	-0.9317	-0.7667
0.750	-1.6094	-1.4570	*****	-0.9173	-0.7498
0.775	*****	-1.4830	-0.8991	-0.9030	-0.7320
0.800	-1.4447	-1.4788	-0.8802	-0.8921	*****
0.825	*****	-1.4388	-0.8714	-0.8905	-0.6987
0.850	-1.3681	-1.4021	-0.8574	-0.8796	-0.6801
0.875	*****	-1.3909	-0.8498	-0.8654	-0.6625
0.900	-1.3618	-1.3915	-0.8345	-0.8521	-0.6416
0.925	*****	-1.3915	-0.8196	-0.8294	-0.6313
0.950	-1.3526	-1.3849	-0.8159	-0.8198	-0.5956
0.975	*****	-1.3807	-0.8101	-0.7888	-0.5613
1.000	-1.4162	-1.4097	-0.7156	-0.7683	-0.5286
	$C_{p,l}$	$C_{p,l}$	$C_{p,l}$	$C_{p,l}$	$C_{p,l}$
-0.200	0.6504	0.5788	0.5299	*****	-0.4659
-0.400	0.6516	0.5806	0.5073	0.2959	-0.5201
-0.600	0.6474	0.5756	0.4931	0.3156	-0.4937
-0.700	0.6292	0.5686	0.4900	0.3220	-0.4638
-0.800	0.5711	0.5412	0.4750	0.3304	-0.3915
-0.850	0.5135	0.5033	0.4539	0.3276	-0.3789
-0.900	*****	0.4160	0.3934	0.3025	-0.3364
-0.950	0.1801	0.2141	0.2182	0.1862	-0.1385
-0.975	*****	-0.0570	-0.0119	0.0016	-0.1487
-1.000	-1.4183	-1.3422	-0.8637	-0.6871	-0.5265

Medium Radius L.E.
 Run No. = 8, Point No. = 170
 $C_N = 1.181$, $C_m = -0.2030$
 $\alpha = 26.6^\circ$, $M_\infty = 0.870$
 $R_{mac} = 6.0 \times 10^6$

Leading Edge Pressures
 ● starboard
 ○ port



x/c_R	starb'd C_p	port C_p
0.10	-1.3594	*****
0.20	-1.4162	-1.4183
0.30	-1.4503	*****
0.40	-1.4097	-1.3422
0.50	-1.0627	*****
0.60	-0.7156	-0.8637
0.70	-0.8173	*****
0.80	-0.7683	-0.6871
0.90	*****	*****
0.95	-0.5286	-0.5265

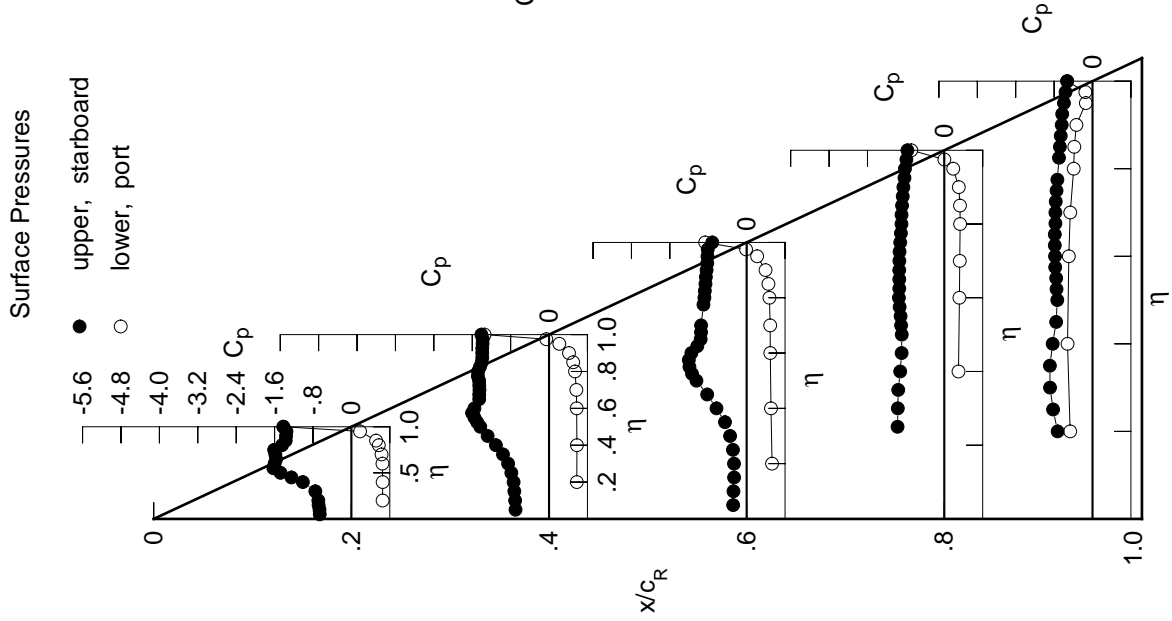

Table F4. Tabulations and Plots of Surface Pressure Coefficients.

η	$x/c_R = .2$		$x/c_R = .4$		$x/c_R = .6$		$x/c_R = .8$		$x/c_R = .95$	
	$C_{p,u}$	$C_{p,u}$	$C_{p,u}$	$C_{p,u}$	$C_{p,u}$	$C_{p,u}$	$C_{p,u}$	$C_{p,u}$	$C_{p,u}$	$C_{p,u}$
0.050	-0.0067	0.0070	0.1464	*****	*****	*****	*****	*****	*****	*****
0.100	-0.0059	0.0078	0.1367	*****	*****	*****	*****	*****	*****	*****
0.150	-0.0089	0.0053	0.1245	*****	*****	*****	*****	*****	*****	*****
0.200	-0.0129	0.0123	0.1132	*****	*****	*****	*****	*****	*****	*****
0.250	*****	0.0063	0.0990	-0.1312	-0.16121	*****	*****	*****	*****	*****
0.300	-0.0189	0.0059	0.0864	-0.1174	-0.5986	*****	*****	*****	*****	*****
0.350	*****	0.0058	0.0796	-0.1022	-0.6098	*****	*****	*****	*****	*****
0.400	-0.0340	0.0029	0.0703	-0.0921	-0.6350	*****	*****	*****	*****	*****
0.450	-0.0374	0.0014	0.0647	-0.0858	-0.6481	*****	*****	*****	*****	*****
0.500	-0.0463	-0.0021	0.0540	-0.0786	-0.6677	*****	*****	*****	*****	*****
0.525	*****	0.0017	0.0516	-0.0746	-0.6776	*****	*****	*****	*****	*****
0.550	-0.0506	-0.0032	0.0474	-0.0755	-0.6835	*****	*****	*****	*****	*****
0.575	*****	-0.0036	0.0490	-0.0705	-0.6922	*****	*****	*****	*****	*****
0.600	-0.0531	-0.0067	0.0379	-0.0695	-0.6964	*****	*****	*****	*****	*****
0.625	*****	*****	0.0392	-0.0692	-0.6947	*****	*****	*****	*****	*****
0.650	-0.0547	-0.0281	0.0340	-0.0673	-0.6939	*****	*****	*****	*****	*****
0.675	*****	-0.0333	0.0299	-0.0659	-0.6828	*****	*****	*****	*****	*****
0.700	-0.0510	-0.0396	0.0264	-0.0662	-0.6920	*****	*****	*****	*****	*****
0.725	*****	-0.0464	*****	-0.0667	-0.6870	*****	*****	*****	*****	*****
0.750	-0.0402	-0.0507	*****	-0.0676	-0.6736	*****	*****	*****	*****	*****
0.775	*****	-0.0585	-0.0111	-0.0632	-0.6650	*****	*****	*****	*****	*****
0.800	-0.0241	-0.0604	-0.0188	-0.0732	*****	*****	*****	*****	*****	*****
0.825	*****	-0.0598	-0.0274	-0.0821	-0.6601	*****	*****	*****	*****	*****
0.850	-0.0018	-0.0544	-0.0365	-0.0922	-0.5555	*****	*****	*****	*****	*****
0.875	*****	-0.0436	-0.0409	-0.1047	-0.5420	*****	*****	*****	*****	*****
0.900	0.0323	-0.0304	-0.0378	-0.1113	-0.5026	*****	*****	*****	*****	*****
0.925	*****	-0.0049	-0.0222	-0.1044	-0.4667	*****	*****	*****	*****	*****
0.950	0.0807	0.0277	0.0043	-0.0768	-0.3443	*****	*****	*****	*****	*****
0.975	*****	0.0822	0.0612	-0.0141	-0.1976	*****	*****	*****	*****	*****
1.000	0.1989	0.1927	0.1515	0.1343	0.0440	*****	*****	*****	*****	*****
	$C_{p,l}$	$C_{p,l}$	$C_{p,l}$	$C_{p,l}$	$C_{p,l}$	$C_{p,l}$	$C_{p,l}$	$C_{p,l}$	$C_{p,l}$	$C_{p,l}$
-0.200	-0.0318	-0.0082	0.0909	*****	-0.5752	*****	*****	*****	*****	*****
-0.400	-0.0599	-0.0086	0.0476	-0.1019	-0.5946	*****	*****	*****	*****	*****
-0.600	-0.0861	-0.0183	0.0142	-0.0879	-0.6925	*****	*****	*****	*****	*****
-0.700	-0.0864	-0.0703	0.0014	-0.0872	-0.7000	*****	*****	*****	*****	*****
-0.800	-0.0713	-0.0981	-0.0622	-0.0962	-0.6419	*****	*****	*****	*****	*****
-0.850	-0.0514	-0.1010	-0.0826	-0.1340	-0.5437	*****	*****	*****	*****	*****
-0.900	*****	-0.0890	-0.0995	-0.1661	-0.4834	*****	*****	*****	*****	*****
-0.950	0.0303	-0.0379	-0.0682	-0.1540	-0.3665	*****	*****	*****	*****	*****
-0.975	*****	0.0134	-0.0190	-0.1018	-0.2554	*****	*****	*****	*****	*****
-1.000	0.1947	0.1814	0.1632	0.1292	0.0399	*****	*****	*****	*****	*****

Medium Radius L.E.
 Run No. = 9, Point No. = 171
 $C_N = -0.026$, $C_m = 0.0026$
 $\alpha = -0.5^\circ$, $M_\infty = 0.898$
 $R_{mac} = 6.0 \times 10^6$

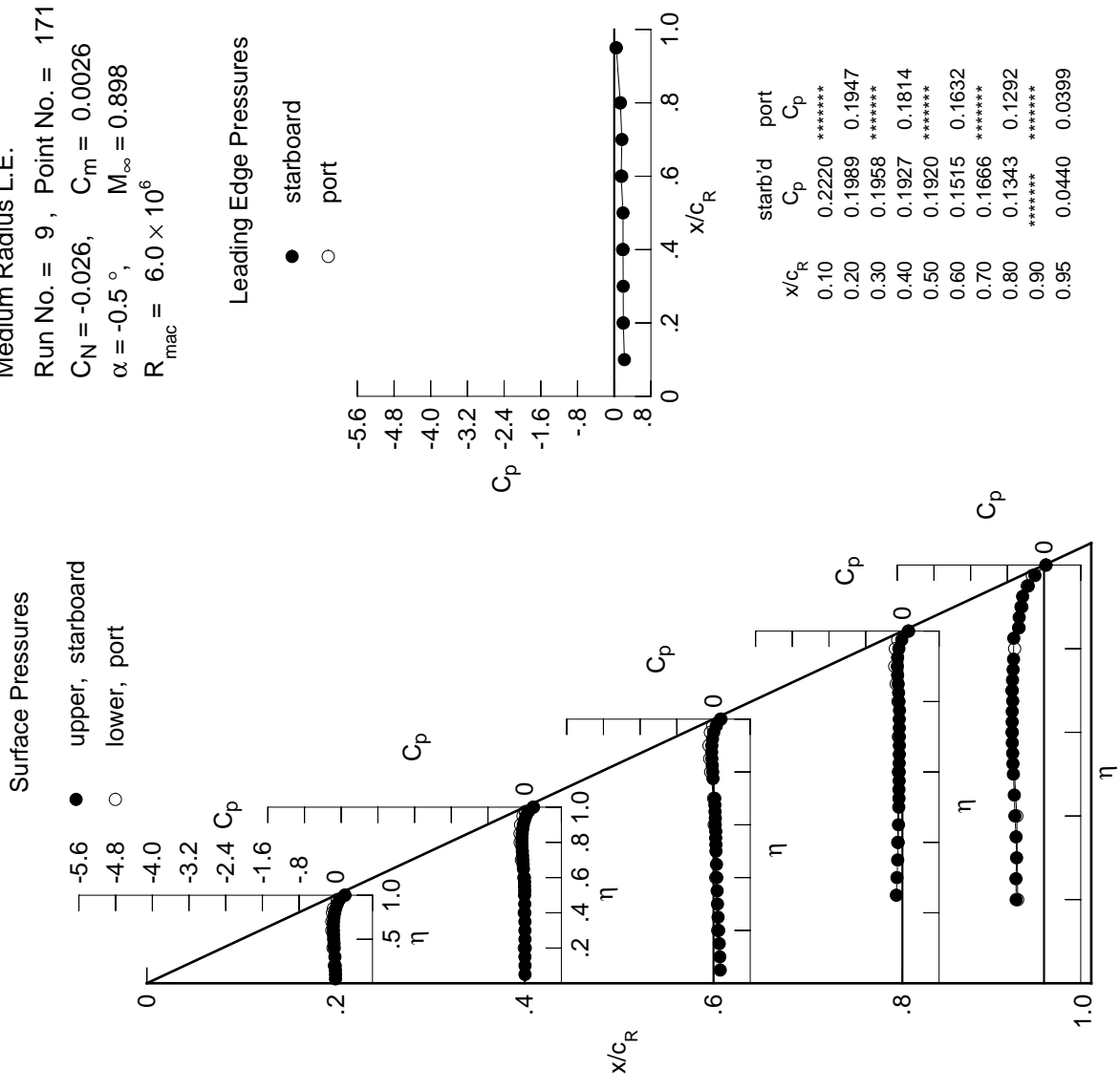
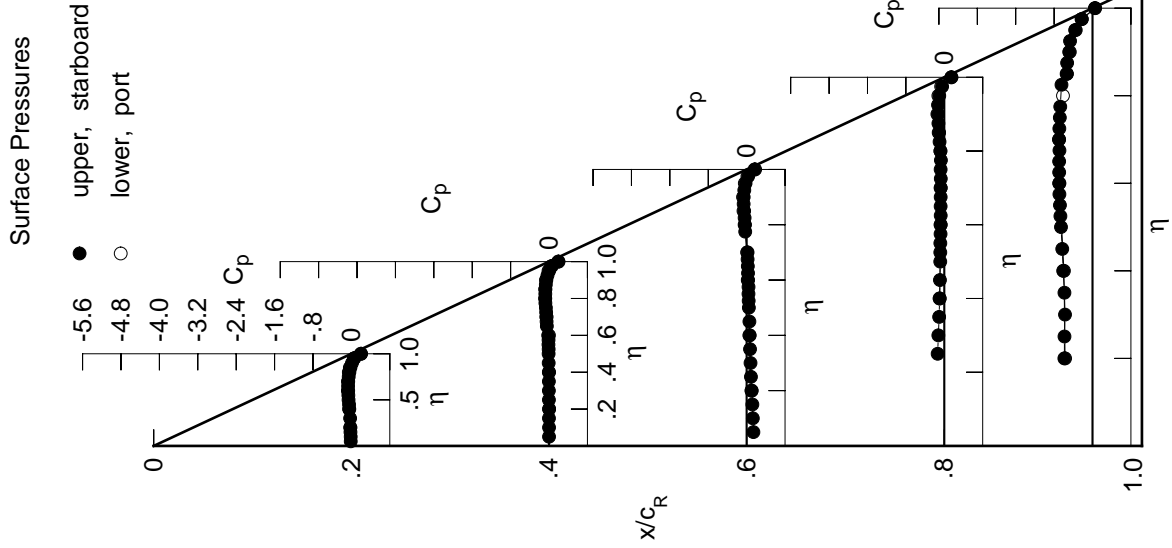

Table F4. Continued.

η	$x/c_R = .2$		$x/c_R = .4$		$x/c_R = .6$		$x/c_R = .8$		$x/c_R = .95$	
	$C_{p,u}$	$C_{p,u}$	$C_{p,u}$	$C_{p,u}$	$C_{p,u}$	$C_{p,u}$	$C_{p,u}$	$C_{p,u}$	$C_{p,u}$	$C_{p,u}$
0.050	-0.0139	-0.0004	0.1410	*****	*****	*****	*****	*****	*****	*****
0.100	-0.0144	-0.0003	0.1290	*****	*****	*****	*****	*****	*****	*****
0.150	-0.0196	-0.0016	0.1196	*****	*****	*****	*****	*****	*****	*****
0.200	-0.0236	0.0017	0.1059	*****	*****	*****	*****	*****	*****	*****
0.250	*****	-0.0027	0.0900	-0.1384	-0.5843	*****	*****	*****	*****	*****
0.300	-0.0266	-0.0029	0.0808	-0.1236	-0.5725	*****	*****	*****	*****	*****
0.350	*****	-0.0035	0.0701	-0.1075	-0.5847	*****	*****	*****	*****	*****
0.400	-0.0442	-0.0038	0.0638	-0.0980	-0.6114	*****	*****	*****	*****	*****
0.450	-0.0489	-0.0074	0.0575	-0.0907	-0.6303	*****	*****	*****	*****	*****
0.500	-0.0589	-0.0087	0.0462	-0.0841	-0.6571	*****	*****	*****	*****	*****
0.525	*****	-0.0079	0.0428	-0.0833	-0.6691	*****	*****	*****	*****	*****
0.550	-0.0635	-0.0116	0.0384	-0.0820	-0.6787	*****	*****	*****	*****	*****
0.575	*****	-0.0107	0.0392	-0.0779	-0.6892	*****	*****	*****	*****	*****
0.600	-0.0664	-0.0175	0.0296	-0.0747	-0.6935	*****	*****	*****	*****	*****
0.625	*****	*****	0.0286	-0.0742	-0.6944	*****	*****	*****	*****	*****
0.650	-0.0686	-0.0456	0.0248	-0.0759	-0.6950	*****	*****	*****	*****	*****
0.675	*****	-0.0511	0.0200	-0.0755	-0.6884	*****	*****	*****	*****	*****
0.700	-0.0660	-0.0553	0.0194	-0.0748	-0.6950	*****	*****	*****	*****	*****
0.725	*****	-0.0603	*****	-0.0727	-0.6910	*****	*****	*****	*****	*****
0.750	-0.0559	-0.0654	*****	-0.0757	-0.6805	*****	*****	*****	*****	*****
0.775	*****	-0.0760	-0.0297	-0.0702	-0.6719	*****	*****	*****	*****	*****
0.800	-0.0419	-0.0788	-0.0353	-0.0802	*****	*****	*****	*****	*****	*****
0.825	*****	-0.0778	-0.0424	-0.0988	-0.6462	*****	*****	*****	*****	*****
0.850	-0.0197	-0.0751	-0.0521	-0.1082	-0.5329	*****	*****	*****	*****	*****
0.875	*****	-0.0673	-0.0627	-0.1221	-0.5286	*****	*****	*****	*****	*****
0.900	0.0130	-0.0557	-0.0613	-0.1314	-0.4859	*****	*****	*****	*****	*****
0.925	*****	-0.0324	-0.0487	-0.1303	-0.4682	*****	*****	*****	*****	*****
0.950	0.0607	0.0026	-0.0221	-0.1050	-0.3612	*****	*****	*****	*****	*****
0.975	*****	0.0559	0.0313	-0.0458	-0.2218	*****	*****	*****	*****	*****
1.000	0.2008	0.1972	0.1647	0.1488	0.0505	*****	*****	*****	*****	*****
	$C_{p,l}$	$C_{p,l}$	$C_{p,l}$	$C_{p,l}$	$C_{p,l}$	$C_{p,l}$	$C_{p,l}$	$C_{p,l}$	$C_{p,l}$	$C_{p,l}$
-0.200	-0.0208	0.0013	0.0997	*****	-0.5715	*****	*****	*****	*****	*****
-0.400	-0.0455	0.0012	0.0571	-0.0949	-0.5955	*****	*****	*****	*****	*****
-0.600	-0.0728	-0.0017	0.0234	-0.0777	-0.6895	*****	*****	*****	*****	*****
-0.700	-0.0708	-0.0529	0.0105	-0.0760	-0.6986	*****	*****	*****	*****	*****
-0.800	-0.0533	-0.0812	-0.0426	-0.0808	-0.6153	*****	*****	*****	*****	*****
-0.850	-0.0319	-0.0797	-0.0656	-0.1170	-0.5393	*****	*****	*****	*****	*****
-0.900	*****	-0.0635	-0.0750	-0.1443	-0.4727	*****	*****	*****	*****	*****
-0.950	0.0522	-0.0104	-0.0384	-0.1230	-0.3488	*****	*****	*****	*****	*****
-0.975	*****	0.0444	0.0162	-0.0660	-0.2286	*****	*****	*****	*****	*****
-1.000	0.1997	0.1919	0.1769	0.1463	0.0547	*****	*****	*****	*****	*****



Medium Radius L.E.
 Run No. = 9, Point No. = 172
 $C_N = -0.0006$, $C_m = -0.0008$
 $\alpha = 0.0^\circ$, $M_\infty = 0.897$
 $R_{mac} = 6.0 \times 10^6$

Leading Edge Pressures

● starboard
○ port

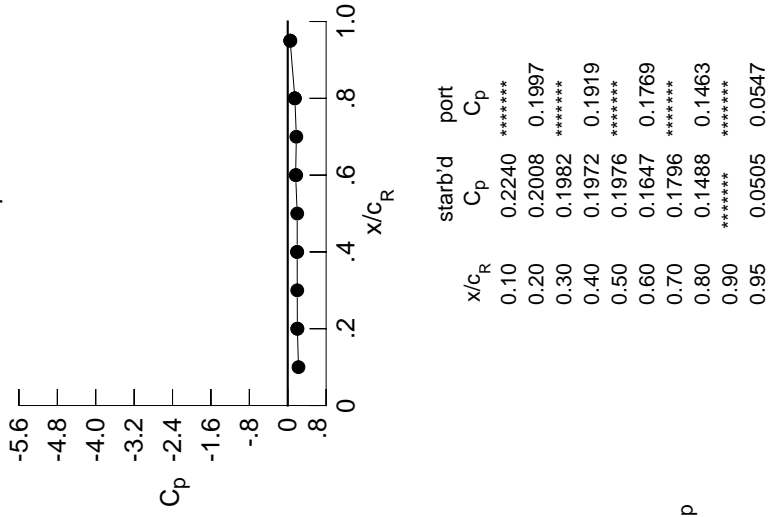

Table F4. Continued.

η	$x/c_R = .2$		$x/c_R = .4$		$x/c_R = .6$		$x/c_R = .8$		$x/c_R = .95$	
	$C_{p,u}$	$C_{p,u}$	$C_{p,u}$	$C_{p,u}$	$C_{p,u}$	$C_{p,u}$	$C_{p,u}$	$C_{p,u}$	$C_{p,u}$	$C_{p,u}$
0.050	-0.0359	-0.0189	0.1260	*****	*****	*****	*****	*****	*****	*****
0.100	-0.0344	-0.0182	0.1164	*****	*****	*****	*****	*****	*****	*****
0.150	-0.0396	-0.0212	0.1082	*****	*****	*****	*****	*****	*****	*****
0.200	-0.0426	-0.0172	0.0920	*****	*****	*****	*****	*****	*****	*****
0.250	*****	-0.0203	0.0796	-0.1523	-0.5497	*****	*****	*****	*****	*****
0.300	-0.0477	-0.0227	0.0651	-0.1380	-0.5589	*****	*****	*****	*****	*****
0.350	*****	-0.0229	0.0564	-0.1248	-0.5605	*****	*****	*****	*****	*****
0.400	-0.0716	-0.0256	0.0469	-0.1132	-0.5876	*****	*****	*****	*****	*****
0.450	-0.0794	-0.0290	0.0427	-0.1093	-0.6107	*****	*****	*****	*****	*****
0.500	-0.0863	-0.0298	0.0297	-0.1011	-0.6459	*****	*****	*****	*****	*****
0.525	*****	-0.0305	0.0276	-0.0996	-0.6502	*****	*****	*****	*****	*****
0.550	-0.0901	-0.0318	0.0234	-0.0998	-0.6750	*****	*****	*****	*****	*****
0.575	*****	-0.0313	0.0203	-0.0956	-0.6859	*****	*****	*****	*****	*****
0.600	-0.0970	-0.0281	0.0159	-0.0939	-0.6918	*****	*****	*****	*****	*****
0.625	*****	*****	0.0102	-0.0949	-0.6917	*****	*****	*****	*****	*****
0.650	-0.1001	-0.0839	0.0051	-0.0948	-0.6973	*****	*****	*****	*****	*****
0.675	*****	-0.0882	0.0020	-0.0980	-0.6967	*****	*****	*****	*****	*****
0.700	-0.1023	-0.0900	0.0016	-0.0953	-0.7047	*****	*****	*****	*****	*****
0.725	*****	-0.0950	*****	-0.0969	-0.7026	*****	*****	*****	*****	*****
0.750	-0.0935	-0.1017	*****	-0.0998	-0.6905	*****	*****	*****	*****	*****
0.775	*****	-0.1140	-0.0675	-0.0966	-0.6803	*****	*****	*****	*****	*****
0.800	-0.0822	-0.1189	-0.0864	-0.0956	*****	*****	*****	*****	*****	*****
0.825	*****	-0.1227	-0.0860	-0.1437	-0.6225	*****	*****	*****	*****	*****
0.850	-0.0634	-0.1235	-0.0963	-0.1485	-0.5067	*****	*****	*****	*****	*****
0.875	*****	-0.1177	-0.1109	-0.1645	-0.4917	*****	*****	*****	*****	*****
0.900	-0.0329	-0.1108	-0.1166	-0.1832	-0.4663	*****	*****	*****	*****	*****
0.925	*****	-0.0920	-0.1108	-0.1881	-0.4555	*****	*****	*****	*****	*****
0.950	0.0117	-0.0604	-0.0933	-0.1742	-0.3974	*****	*****	*****	*****	*****
0.975	*****	-0.0123	-0.0454	-0.1241	-0.2837	*****	*****	*****	*****	*****
1.000	0.1867	0.1738	0.1421	0.1163	0.0247	*****	*****	*****	*****	*****
η	$C_{p,l}$	$C_{p,l}$	$C_{p,l}$	$C_{p,l}$	$C_{p,l}$	$C_{p,l}$	$C_{p,l}$	$C_{p,l}$	$C_{p,l}$	$C_{p,l}$
-0.200	-0.0015	0.0177	0.1102	*****	*****	*****	*****	*****	*****	-0.6073
-0.400	-0.0273	0.0170	0.0686	-0.0803	-0.6290	*****	*****	*****	*****	*****
-0.600	-0.0446	0.0077	0.0399	-0.0624	-0.6912	*****	*****	*****	*****	*****
-0.700	-0.0384	-0.0250	0.0272	-0.0568	-0.6877	*****	*****	*****	*****	*****
-0.800	-0.0149	-0.0429	-0.0099	-0.0577	-0.6549	*****	*****	*****	*****	*****
-0.850	0.0083	-0.0363	-0.0307	-0.0818	-0.6382	*****	*****	*****	*****	*****
-0.900	*****	-0.0128	-0.0257	-0.0991	-0.5300	*****	*****	*****	*****	*****
-0.950	0.0963	0.0451	0.0219	-0.0610	-0.3155	*****	*****	*****	*****	*****
-0.975	*****	0.1011	0.0801	0.0011	-0.1770	*****	*****	*****	*****	*****
-1.000	0.1933	0.1791	0.1576	0.1321	0.0430	*****	*****	*****	*****	*****

Medium Radius L.E.

Run No. = 9, Point No. = 173

$C_N = 0.039$, $C_m = -0.0102$

$\alpha = 1.1^\circ$, $M_\infty = 0.898$

$R_{mac} = 6.0 \times 10^6$

Leading Edge Pressures

- starboard
- port

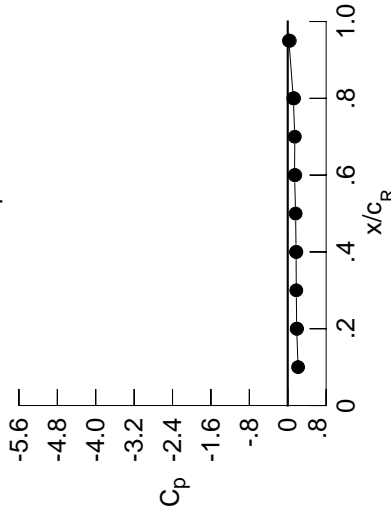

x/c_R	starb'd C_p	port C_p
0.10	0.2156	*****
0.20	0.1867	0.1933
0.30	0.1780	*****
0.40	0.1738	0.1791
0.50	0.1642	*****
0.60	0.1421	0.1576
0.70	0.1472	*****
0.80	0.1163	0.1321
0.90	*****	*****
0.95	0.0247	0.0430

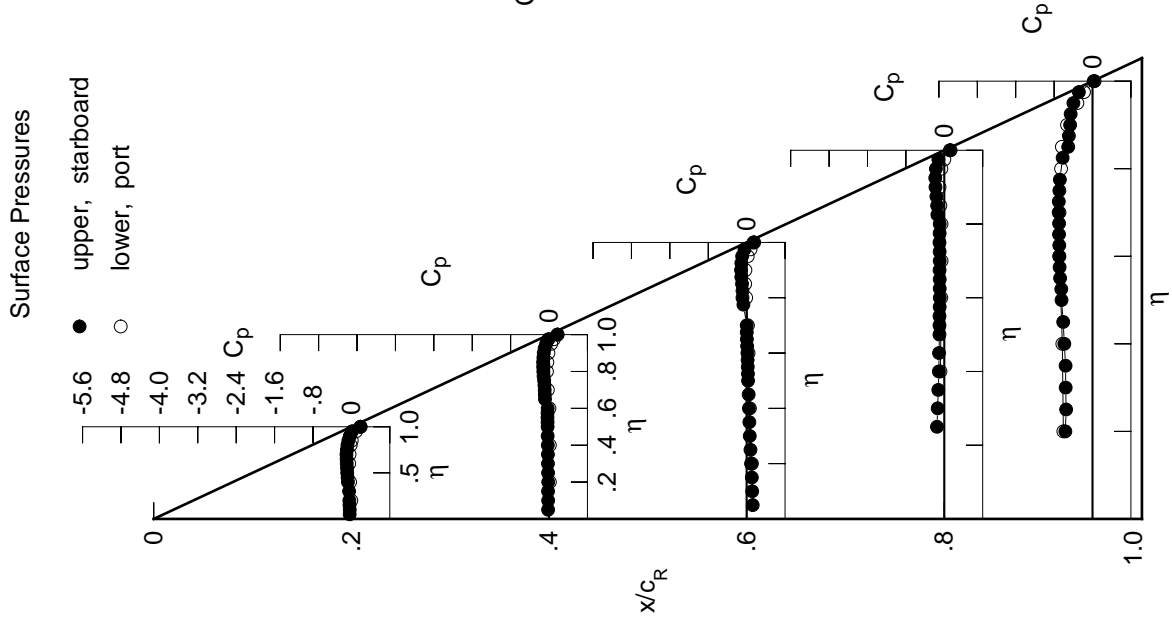

Table F4. Continued.

η	$x/c_R = .2$		$x/c_R = .4$		$x/c_R = .6$		$x/c_R = .8$		$x/c_R = .95$	
	$C_{p,u}$	$C_{p,u}$	$C_{p,u}$	$C_{p,u}$	$C_{p,u}$	$C_{p,u}$	$C_{p,u}$	$C_{p,u}$	$C_{p,u}$	$C_{p,u}$
0.050	-0.0552	-0.0334	0.1172	*****	*****	*****	*****	*****	*****	*****
0.100	-0.0534	-0.0354	0.1031	*****	*****	*****	*****	*****	*****	*****
0.150	-0.0557	-0.0399	0.0969	*****	*****	*****	*****	*****	*****	*****
0.200	-0.0633	-0.0337	0.0800	*****	*****	*****	*****	*****	*****	-0.5321
0.250	*****	-0.0359	0.0665	-0.1710	-0.5060	*****	*****	*****	*****	*****
0.300	-0.0659	-0.0402	0.0507	-0.1513	-0.5104	*****	*****	*****	*****	*****
0.350	*****	-0.0408	0.0438	-0.1415	-0.5153	*****	*****	*****	*****	*****
0.400	-0.0946	-0.0452	0.0321	-0.1257	-0.5351	*****	*****	*****	*****	*****
0.450	-0.1072	-0.0450	0.0280	-0.1274	-0.5786	*****	*****	*****	*****	*****
0.500	-0.1109	-0.0518	0.0115	-0.1171	-0.6112	*****	*****	*****	*****	*****
0.525	*****	-0.0480	0.0108	-0.1180	-0.6363	*****	*****	*****	*****	*****
0.550	-0.1170	-0.0539	0.0033	-0.1148	-0.6502	*****	*****	*****	*****	*****
0.575	*****	-0.0534	0.0051	-0.1133	-0.6655	*****	*****	*****	*****	*****
0.600	-0.1252	-0.0527	0.0053	-0.1106	-0.6679	*****	*****	*****	*****	*****
0.625	*****	*****	-0.0087	-0.1112	-0.6747	*****	*****	*****	*****	*****
0.650	-0.1314	-0.0916	0.0166	-0.1140	-0.6953	*****	*****	*****	*****	*****
0.675	*****	-0.1306	-0.0190	-0.1152	-0.7020	*****	*****	*****	*****	*****
0.700	-0.1372	-0.1306	-0.0267	-0.1171	-0.7107	*****	*****	*****	*****	*****
0.725	*****	-0.1371	*****	-0.1181	-0.7121	*****	*****	*****	*****	*****
0.750	-0.1309	-0.1406	*****	-0.1239	-0.6937	*****	*****	*****	*****	*****
0.775	*****	-0.1506	-0.0497	-0.1205	-0.6749	*****	*****	*****	*****	*****
0.800	-0.1237	-0.1580	-0.1277	-0.1291	*****	*****	*****	*****	*****	*****
0.825	*****	-0.1676	-0.1329	-0.1290	-0.5540	*****	*****	*****	*****	*****
0.850	-0.1073	-0.1717	-0.1395	-0.2044	-0.4610	*****	*****	*****	*****	*****
0.875	*****	-0.1733	-0.1590	-0.2112	-0.4305	*****	*****	*****	*****	*****
0.900	-0.0829	-0.1694	-0.1709	-0.2326	-0.4245	*****	*****	*****	*****	*****
0.925	*****	-0.1569	-0.1781	-0.2492	-0.4010	*****	*****	*****	*****	*****
0.950	-0.0431	-0.1296	-0.1696	-0.2482	-0.4055	*****	*****	*****	*****	*****
0.975	*****	-0.0957	-0.1380	-0.2166	-0.3546	*****	*****	*****	*****	*****
1.000	0.1491	0.1098	0.0690	0.0141	-0.0547	*****	*****	*****	*****	*****
	$C_{p,l}$	$C_{p,l}$	$C_{p,l}$	$C_{p,l}$	$C_{p,l}$	$C_{p,l}$	$C_{p,l}$	$C_{p,l}$	$C_{p,l}$	$C_{p,l}$
-0.200	0.0218	0.0366	0.1259	*****	*****	*****	*****	*****	*****	-0.6186
-0.400	-0.0040	0.0388	0.0842	-0.0629	-0.6450	*****	*****	*****	*****	*****
-0.600	-0.0152	0.0288	0.0599	-0.0437	-0.6841	*****	*****	*****	*****	*****
-0.700	-0.0049	0.0078	0.0465	-0.0386	-0.6795	*****	*****	*****	*****	*****
-0.800	0.0220	-0.0058	0.0268	-0.0359	-0.6421	*****	*****	*****	*****	*****
-0.850	0.0470	0.0060	0.0112	-0.0438	-0.6633	*****	*****	*****	*****	*****
-0.900	*****	0.0337	0.0204	-0.0565	-0.6466	*****	*****	*****	*****	*****
-0.950	0.1344	0.0936	0.0746	-0.0092	-0.2883	*****	*****	*****	*****	*****
-0.975	*****	0.1459	0.1306	0.0551	-0.1365	*****	*****	*****	*****	*****
-1.000	0.1613	0.1196	0.0725	0.0471	-0.0212	*****	*****	*****	*****	*****

Medium Radius L.E.
 Run No. = 9, Point No. = 174
 $C_N = 0.084$, $C_m = -0.0193$
 $\alpha = 2.1^\circ$, $M_\infty = 0.898$
 $R_{mac} = 6.0 \times 10^6$

Leading Edge Pressures

● starboard
 ○ port

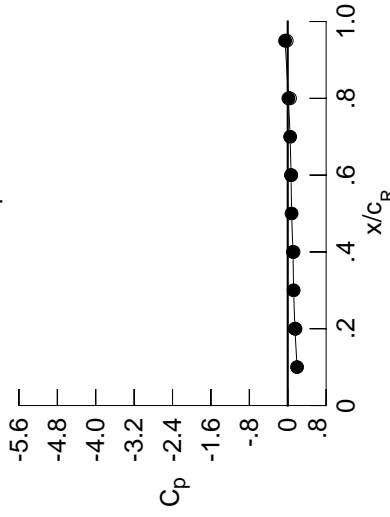

x/c_R	starb'd C_p	port C_p
0.10	0.1947	*****
0.20	0.1491	0.1613
0.30	0.1222	*****
0.40	0.1098	0.1196
0.50	0.0798	*****
0.60	0.0690	0.0725
0.70	0.0507	*****
0.80	0.0141	0.0471
0.90	*****	*****
0.95	-0.0547	-0.0212

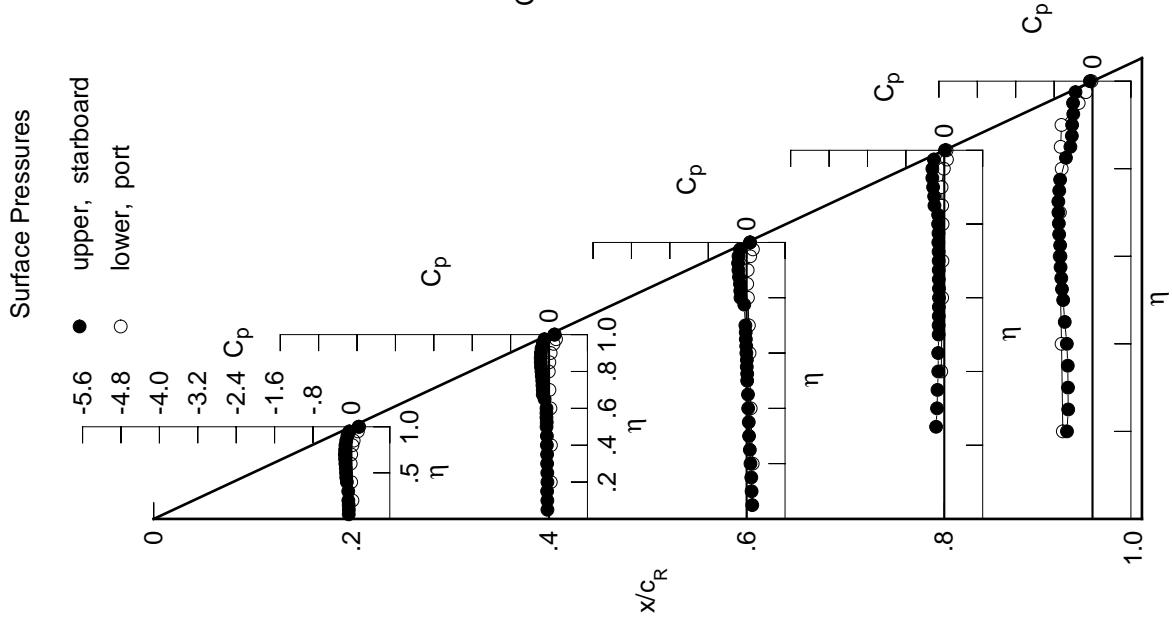

Table F4. Continued.

η	$x/c_R = .2$		$x/c_R = .4$		$x/c_R = .6$		$x/c_R = .8$		$x/c_R = .95$	
	$C_{p,u}$	$C_{p,u}$	$C_{p,u}$	$C_{p,u}$	$C_{p,u}$	$C_{p,u}$	$C_{p,u}$	$C_{p,u}$	$C_{p,u}$	$C_{p,u}$
0.050	-0.0731	-0.0543	0.1037	*****	*****	*****	*****	*****	*****	*****
0.100	-0.0714	-0.0549	0.0914	*****	*****	*****	*****	*****	*****	*****
0.150	-0.0746	-0.0549	0.0852	*****	*****	*****	*****	*****	*****	*****
0.200	-0.0821	-0.0512	0.0669	*****	*****	*****	*****	*****	*****	*****
0.250	*****	-0.0561	0.0541	-0.1837	-0.4892	*****	*****	*****	*****	*****
0.300	-0.0881	-0.0572	0.0380	-0.1682	-0.4704	*****	*****	*****	*****	*****
0.350	*****	-0.0604	0.0300	-0.1548	-0.4778	*****	*****	*****	*****	*****
0.400	-0.1189	-0.0630	0.0178	-0.1447	-0.4866	*****	*****	*****	*****	*****
0.450	-0.1287	-0.0678	0.0122	-0.1403	-0.5340	*****	*****	*****	*****	*****
0.500	-0.1367	-0.0723	-0.0028	-0.1332	-0.5773	*****	*****	*****	*****	*****
0.525	*****	-0.0722	-0.0061	-0.1340	-0.6079	*****	*****	*****	*****	*****
0.550	-0.1444	-0.0810	-0.0134	-0.1328	-0.6211	*****	*****	*****	*****	*****
0.575	*****	-0.0813	-0.0153	-0.1320	-0.6314	*****	*****	*****	*****	*****
0.600	-0.1540	-0.0849	-0.0248	-0.1305	-0.6358	*****	*****	*****	*****	*****
0.625	*****	*****	-0.0288	-0.1326	-0.6595	*****	*****	*****	*****	*****
0.650	-0.1641	-0.0889	-0.0345	-0.1351	-0.6815	*****	*****	*****	*****	*****
0.675	*****	-0.1321	-0.0440	-0.1381	-0.6894	*****	*****	*****	*****	*****
0.700	-0.1714	-0.1706	-0.0501	-0.1411	-0.7070	*****	*****	*****	*****	*****
0.725	*****	-0.1770	*****	-0.1426	-0.7085	*****	*****	*****	*****	*****
0.750	-0.1702	-0.1800	*****	-0.1500	-0.6963	*****	*****	*****	*****	*****
0.775	*****	-0.1917	-0.0897	-0.1535	-0.6694	*****	*****	*****	*****	*****
0.800	-0.1664	-0.2001	-0.1164	-0.1661	*****	*****	*****	*****	*****	*****
0.825	*****	-0.2120	-0.1893	-0.1703	-0.5745	*****	*****	*****	*****	*****
0.850	-0.1560	-0.2227	-0.1948	-0.2237	-0.4790	*****	*****	*****	*****	*****
0.875	*****	-0.2289	-0.2125	-0.2715	-0.4839	*****	*****	*****	*****	*****
0.900	-0.1358	-0.2324	-0.2328	-0.2894	-0.4707	*****	*****	*****	*****	*****
0.925	*****	-0.2261	-0.2463	-0.3160	-0.4737	*****	*****	*****	*****	*****
0.950	-0.1054	-0.2103	-0.2543	-0.3302	-0.4122	*****	*****	*****	*****	*****
0.975	*****	-0.1890	-0.2404	-0.3213	-0.4230	*****	*****	*****	*****	*****
1.000	0.0888	-0.0016	-0.0324	-0.1459	-0.1898	*****	*****	*****	*****	*****
-0.200	$C_{p,l}$	$C_{p,l}$	$C_{p,l}$	$C_{p,l}$	$C_{p,l}$	$C_{p,l}$	$C_{p,l}$	$C_{p,l}$	$C_{p,l}$	$C_{p,l}$
-0.400	0.0396	0.0525	0.1379	*****	-0.6285	*****	*****	*****	*****	*****
-0.600	0.0243	0.0567	0.0968	-0.0515	-0.6595	*****	*****	*****	*****	*****
-0.700	0.0118	0.0515	0.0763	-0.0333	-0.6793	*****	*****	*****	*****	*****
-0.800	0.0261	0.0335	0.0677	-0.0211	-0.6685	*****	*****	*****	*****	*****
-0.850	0.0554	0.0277	0.0524	-0.0158	-0.6291	*****	*****	*****	*****	*****
-0.900	0.0806	0.0427	0.0450	-0.0203	-0.6446	*****	*****	*****	*****	*****
-0.950	*****	0.0736	0.0592	-0.0146	-0.6496	*****	*****	*****	*****	*****
-0.975	0.1645	0.1315	0.1162	0.0345	-0.2658	*****	*****	*****	*****	*****
-1.000	*****	0.1769	0.1648	0.0953	-0.1070	*****	*****	*****	*****	*****
	0.1011	0.0168	-0.0742	-0.1038	-0.1347	*****	*****	*****	*****	*****

Medium Radius L.E.

Run No. = 9, Point No. = 175

$C_N = 0.131$, $C_m = -0.0308$

$\alpha = 3.2^\circ$, $M_\infty = 0.899$

$R_{mac} = 6.0 \times 10^6$

Leading Edge Pressures

- starboard
- port

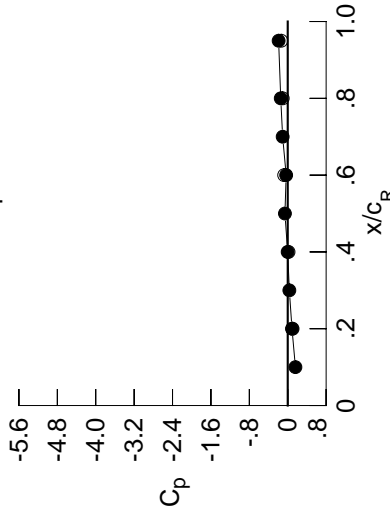

x/c_R	starb'd C_p	port C_p
0.10	0.1602	*****
0.20	0.0888	0.1011
0.30	0.0334	*****
0.40	-0.0016	0.0168
0.50	-0.0582	*****
0.60	-0.0324	-0.0742
0.70	-0.1060	*****
0.80	-0.1459	-0.1038
0.90	*****	*****
0.95	-0.1898	-0.1347

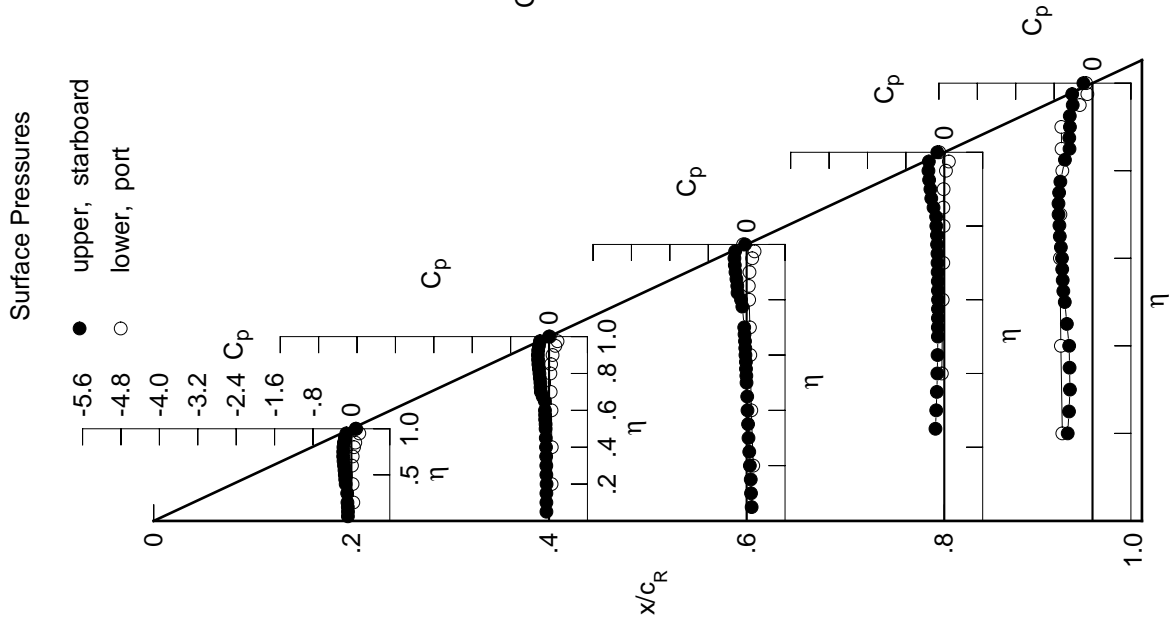

Table F4. Continued.

η	$x/c_R = 0.2$		$x/c_R = 0.4$		$x/c_R = 0.6$		$x/c_R = 0.8$		$x/c_R = 0.95$	
	$C_{p,u}$	$C_{p,l}$	$C_{p,u}$	$C_{p,l}$	$C_{p,u}$	$C_{p,l}$	$C_{p,u}$	$C_{p,l}$	$C_{p,u}$	$C_{p,l}$
0.050	-0.0912	-0.0713	0.0915	*****	*****	*****	*****	*****	*****	*****
0.100	-0.0897	-0.0696	0.0808	*****	*****	*****	*****	*****	*****	*****
0.150	-0.0934	-0.0756	0.0697	*****	*****	*****	*****	*****	*****	*****
0.200	-0.0983	-0.0677	0.0552	*****	*****	*****	*****	*****	*****	*****
0.250	*****	-0.0766	0.0407	-0.1987	-0.1839	-0.4129	-0.4079	-0.4287	-0.5140	-0.4590
0.300	-0.1083	-0.0761	0.0254	-0.1839	-0.1704	-0.4079	-0.4287	-0.5140	-0.4590	-0.4129
0.350	*****	-0.0806	0.0157	-0.1704	-0.4079	-0.4287	-0.5140	-0.4590	-0.4129	-0.3500
0.400	-0.1338	-0.0845	0.0038	-0.1601	-0.4287	-0.5140	-0.4590	-0.4129	-0.3500	-0.3000
0.450	-0.1443	-0.0921	-0.0053	-0.1555	-0.4481	-0.4744	-0.4941	-0.5025	-0.5025	-0.4481
0.500	-0.1565	-0.0985	-0.0198	-0.1510	-0.4744	-0.4941	-0.5025	-0.5025	-0.4481	-0.4000
0.525	*****	-0.1014	-0.0258	-0.1513	-0.4941	-0.5025	-0.5025	-0.4481	-0.4000	-0.3500
0.550	-0.1666	-0.1072	-0.0330	-0.1554	-0.5025	-0.5025	-0.4481	-0.4000	-0.3500	-0.3000
0.575	*****	-0.1128	-0.0357	-0.1533	-0.5219	-0.5346	-0.5476	-0.5666	-0.5794	-0.6065
0.600	-0.1808	-0.1192	-0.0460	-0.1501	-0.5346	-0.5476	-0.5666	-0.5794	-0.6065	-0.6207
0.625	*****	*****	-0.0544	-0.1514	-0.5476	-0.5666	-0.5794	-0.6065	-0.6207	-0.5903
0.650	-0.1929	-0.1376	-0.0603	-0.1562	-0.5666	-0.5794	-0.6065	-0.6207	-0.5903	-0.4819
0.675	*****	-0.1512	-0.0707	-0.1622	-0.5794	-0.6065	-0.6207	-0.5903	-0.4819	-0.2023
0.700	-0.2049	-0.1697	-0.0781	-0.1645	-0.6065	-0.6207	-0.5903	-0.4819	-0.2023	-0.2023
0.725	*****	-0.1866	*****	-0.1701	-0.6207	-0.5903	-0.4819	-0.2023	-0.2023	-0.4050
0.750	-0.2062	-0.2050	*****	-0.1787	-0.5903	-0.4819	-0.2023	-0.4050	-0.4050	-0.4437
0.775	*****	-0.2247	-0.1338	-0.1871	-0.4819	-0.2023	-0.4050	-0.4437	-0.4437	-0.5884
0.800	-0.2048	-0.2457	-0.1631	-0.2023	-0.4819	-0.2023	-0.4050	-0.4437	-0.4437	-0.5987
0.825	*****	-0.2597	-0.1903	-0.2185	-0.4050	-0.4437	-0.5884	-0.5987	-0.5987	-0.7515
0.850	-0.1993	-0.2751	-0.2299	-0.2533	-0.4437	-0.5884	-0.5987	-0.5987	-0.5987	-0.5596
0.875	*****	-0.2867	-0.2642	-0.2984	-0.5884	-0.5987	-0.5987	-0.5987	-0.5987	-0.5386
0.900	-0.1865	-0.2989	-0.2998	-0.3447	-0.5987	-0.5987	-0.5987	-0.5987	-0.5987	-0.3940
0.925	*****	-0.2994	-0.3236	-0.3891	-0.7515	-0.7515	-0.7515	-0.7515	-0.7515	-0.6366
0.950	-0.1727	-0.2953	-0.3488	-0.4193	-0.5596	-0.5987	-0.5987	-0.5987	-0.5987	-0.6615
0.975	*****	-0.3006	-0.3624	-0.4449	-0.5386	-0.5987	-0.5987	-0.5987	-0.5987	-0.6747
1.000	0.0027	-0.1570	-0.1905	-0.3789	-0.3940	-0.3940	-0.3940	-0.3940	-0.3940	-0.6592
-0.200	$C_{p,l}$	0.0602	0.0730	0.1511	*****	*****	*****	*****	*****	*****
-0.400	$C_{p,l}$	0.0491	0.0763	0.1146	-0.0365	-0.6615	-0.6615	-0.6615	-0.6615	-0.6615
-0.600	$C_{p,l}$	0.0420	0.0739	0.0949	-0.0140	-0.6747	-0.6747	-0.6747	-0.6747	-0.6747
-0.700	$C_{p,l}$	0.0592	0.0617	0.0905	-0.0035	-0.6592	-0.6592	-0.6592	-0.6592	-0.6592
-0.800	$C_{p,l}$	0.0903	0.0618	0.0795	0.0106	-0.6156	-0.6156	-0.6156	-0.6156	-0.6156
-0.850	$C_{p,l}$	0.1157	0.0806	0.0817	0.0089	-0.6279	-0.6279	-0.6279	-0.6279	-0.6279
-0.900	$C_{p,l}$	*****	0.1119	0.0965	0.0200	-0.6489	-0.6489	-0.6489	-0.6489	-0.6489
-0.950	$C_{p,l}$	0.1918	0.1657	0.1520	0.0757	-0.2464	-0.2464	-0.2464	-0.2464	-0.2464
-0.975	$C_{p,l}$	*****	0.1992	0.1901	0.1279	-0.0864	-0.0864	-0.0864	-0.0864	-0.0864
-1.000	$C_{p,l}$	0.0158	-0.1342	-0.2961	-0.3273	-0.3097	-0.3097	-0.3097	-0.3097	-0.3097

Medium Radius L.E.
 Run No. = 9, Point No. = 176
 $C_N = 0.174$, $C_m = -0.0368$
 $\alpha = 4.2^\circ$, $M_\infty = 0.898$
 $R_{mac} = 6.0 \times 10^6$

Leading Edge Pressures

● starboard
 ○ port

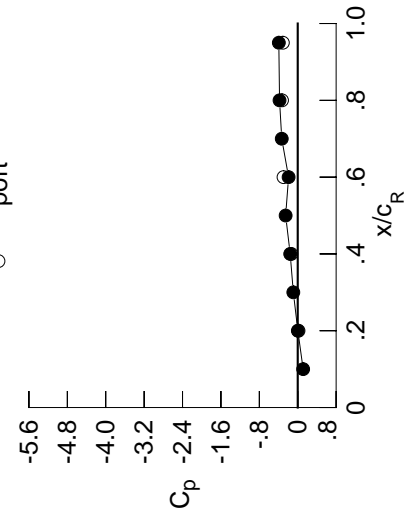

x/c_R	starb'd C_p	port C_p
0.10	0.1126	*****
0.20	0.0027	0.0158
0.30	-0.0918	*****
0.40	-0.1570	-0.1342
0.50	-0.2519	*****
0.60	-0.1905	-0.2961
0.70	-0.3329	*****
0.80	-0.3789	-0.3273
0.90	*****	*****
0.95	-0.3940	-0.3097

Surface Pressures

● upper, starboard
 ○ lower, port

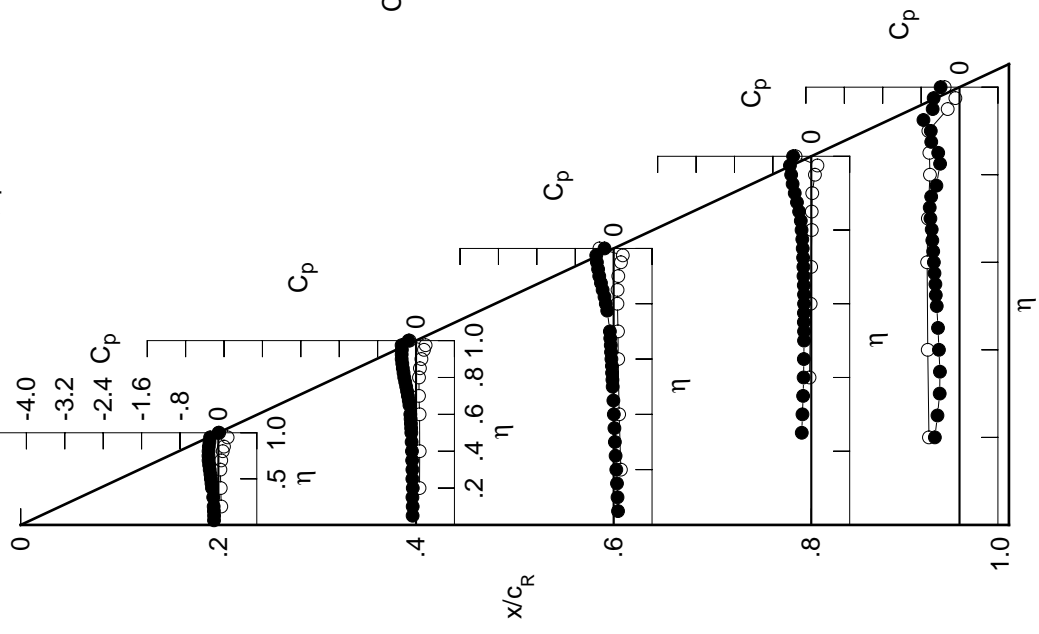

Table F4. Continued.

η	$x/c_R = .2$		$x/c_R = .4$		$x/c_R = .6$		$x/c_R = .8$		$x/c_R = .95$	
	$C_{p,u}$	$C_{p,u}$	$C_{p,u}$	$C_{p,u}$	$C_{p,u}$	$C_{p,u}$	$C_{p,u}$	$C_{p,u}$	$C_{p,u}$	$C_{p,u}$
0.050	-0.1089	-0.0884	0.0777	*****	*****	*****	*****	*****	*****	*****
0.100	-0.1064	-0.0891	0.0689	*****	*****	*****	*****	*****	*****	*****
0.150	-0.1141	-0.0917	0.0587	*****	*****	*****	*****	*****	*****	*****
0.200	-0.1187	-0.0891	0.0425	*****	*****	*****	*****	*****	*****	*****
0.250	*****	-0.0943	0.0253	-0.2136	-0.4435					
0.300	-0.1263	-0.0974	0.0119	-0.1995	-0.3868					
0.350	*****	-0.1015	0.0018	-0.1860	-0.3763					
0.400	-0.1547	-0.1053	-0.0125	-0.1778	-0.3929					
0.450	-0.1671	-0.1134	-0.0231	-0.1722	-0.4227					
0.500	-0.1813	-0.1209	-0.0379	-0.1703	-0.4626					
0.525	*****	-0.1251	-0.0426	-0.1698	-0.4882					
0.550	-0.1936	-0.1316	-0.0503	-0.1744	-0.4995					
0.575	*****	-0.1387	-0.0557	-0.1716	-0.5117					
0.600	-0.2107	-0.1452	-0.0668	-0.1702	-0.5222					
0.625	*****	*****	-0.0750	-0.1751	-0.5349					
0.650	-0.2259	-0.1672	-0.0851	-0.1789	-0.5495					
0.675	*****	-0.1843	-0.0945	-0.1867	-0.5396					
0.700	-0.2412	-0.2022	-0.1065	-0.1920	-0.5510					
0.725	*****	-0.2238	*****	-0.1999	-0.5518					
0.750	-0.2465	-0.2433	*****	-0.2096	-0.5243					
0.775	*****	-0.2689	-0.1676	-0.2224	-0.4596					
0.800	-0.2518	-0.2916	-0.1973	-0.2357	*****					
0.825	*****	-0.3140	-0.2335	-0.2572	-0.4123					
0.850	-0.2522	-0.3321	-0.2773	-0.2957	-0.3847					
0.875	*****	-0.3540	-0.3243	-0.3446	-0.3707					
0.900	-0.2496	-0.3720	-0.3692	-0.4019	-0.3911					
0.925	*****	-0.3851	-0.4088	-0.4628	-0.4455					
0.950	-0.2493	-0.3949	-0.4527	-0.5220	-0.6358					
0.975	*****	-0.4306	-0.4896	-0.5673	-0.6657					
1.000	-0.1091	-0.3542	-0.3887	-0.6593	-0.6404					
-0.200	$C_{p,l}$	0.0824	0.0895	0.1649	*****	$C_{p,l}$	0.1649	*****	$C_{p,l}$	-0.6329
-0.400		0.0711	0.0966	0.1303	-0.0230		0.1303	-0.0230		-0.6648
-0.600		0.0741	0.0944	0.1121	0.0016		0.0016	-0.6642		
-0.700		0.0928	0.0859	0.1089	0.0126		0.0126	-0.6484		
-0.800		0.1246	0.0940	0.1032	0.0269		0.0269	-0.6002		
-0.850		0.1497	0.1160	0.1074	0.0319		0.0319	-0.6071		
-0.900	*****	0.1475	0.1475	0.1293	0.0493		0.0493	-0.6189		
-0.950		0.2144	0.1931	0.1806	0.1041		0.1041	-0.2328		
-0.975	*****	0.2114	0.2048	0.1453	-0.0740		0.1453	-0.0740		
-1.000		-0.0924	-0.3235	-0.5513	-0.5965		-0.5965	-0.5319		

Medium Radius L.E.
 Run No. = 9, Point No. = 177
 $C_N = 0.216$, $C_m = -0.0444$
 $\alpha = 5.2^\circ$, $M_\infty = 0.898$
 $R_{mac} = 6.0 \times 10^6$

Leading Edge Pressures

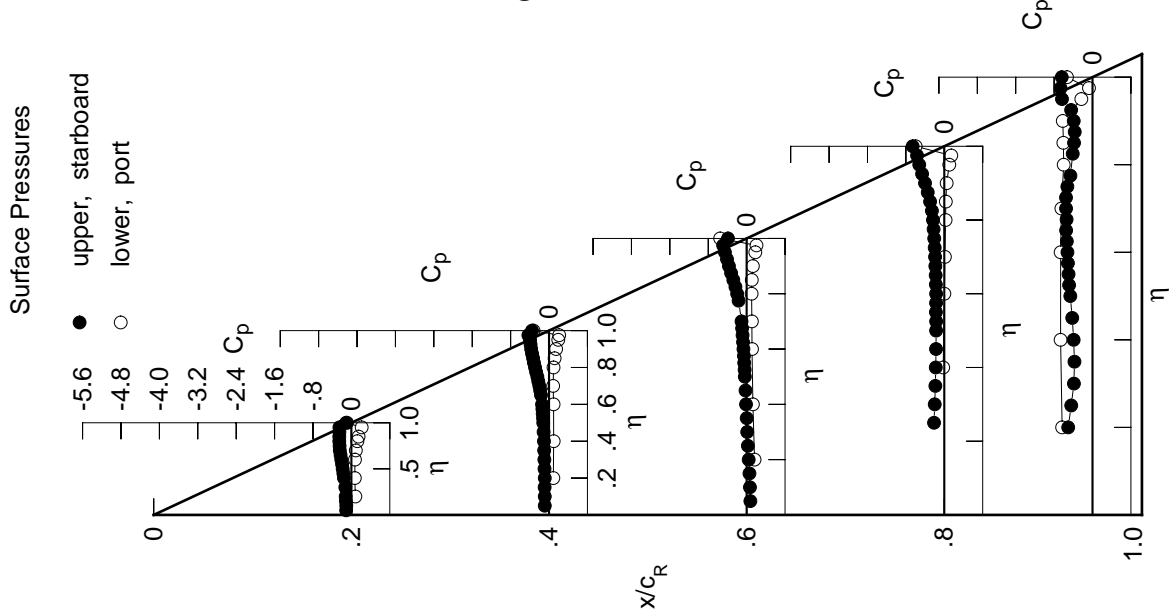
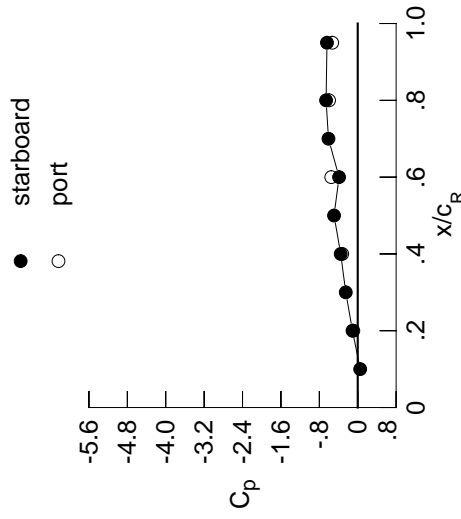

Table F4. Continued.

η	$x/c_R = .2$		$x/c_R = .4$		$x/c_R = .6$		$x/c_R = .8$		$x/c_R = .95$	
	$C_{p,u}$	$C_{p,l}$	$C_{p,u}$	$C_{p,l}$	$C_{p,u}$	$C_{p,l}$	$C_{p,u}$	$C_{p,l}$	$C_{p,u}$	$C_{p,l}$
0.050	-0.1247	-0.1040	0.0687	*****	*****	*****	*****	*****	*****	*****
0.100	-0.1240	-0.1066	0.0558	*****	*****	*****	*****	*****	*****	*****
0.150	-0.1301	-0.1098	0.0475	*****	*****	*****	*****	*****	*****	*****
0.200	-0.1354	-0.1047	0.0287	*****	*****	*****	*****	*****	*****	-0.4766
0.250	*****	-0.1106	0.0152	-0.2294	-0.4014	*****	*****	*****	*****	-0.4014
0.300	-0.1472	-0.1151	-0.0020	-0.2153	-0.3485	*****	*****	*****	*****	-0.3485
0.350	*****	-0.1193	-0.0122	-0.2018	-0.3356	*****	*****	*****	*****	-0.3356
0.400	-0.1759	-0.1281	-0.0265	-0.1939	-0.3582	*****	*****	*****	*****	-0.3582
0.450	-0.1899	-0.1343	-0.0377	-0.1882	-0.3889	*****	*****	*****	*****	-0.3889
0.500	-0.2054	-0.1448	-0.0519	-0.1867	-0.4373	*****	*****	*****	*****	-0.4373
0.525	*****	-0.1473	-0.0608	-0.1853	-0.4762	*****	*****	*****	*****	-0.4762
0.550	-0.2197	-0.1548	-0.0680	-0.1896	-0.5168	*****	*****	*****	*****	-0.5168
0.575	*****	-0.1630	-0.0751	-0.1880	-0.5763	*****	*****	*****	*****	-0.5763
0.600	-0.2400	-0.1701	-0.0879	-0.1897	-0.6075	*****	*****	*****	*****	-0.6075
0.625	*****	*****	-0.0983	-0.1955	-0.6314	*****	*****	*****	*****	-0.6314
0.650	-0.2585	-0.1950	-0.1093	-0.2010	-0.6511	*****	*****	*****	*****	-0.6511
0.675	*****	-0.2134	-0.1214	-0.2115	-0.6467	*****	*****	*****	*****	-0.6467
0.700	-0.2771	-0.2365	-0.1399	-0.2249	-0.6194	*****	*****	*****	*****	-0.6194
0.725	*****	-0.2563	*****	-0.2361	-0.5612	*****	*****	*****	*****	-0.5612
0.750	-0.2883	-0.2804	*****	-0.2535	-0.4996	*****	*****	*****	*****	-0.4996
0.775	*****	-0.3113	-0.2038	-0.2684	-0.4279	*****	*****	*****	*****	-0.4279
0.800	-0.2988	-0.3371	-0.2356	-0.2843	*****	*****	*****	*****	*****	*****
0.825	*****	-0.3667	-0.2728	-0.3035	-0.3772	*****	*****	*****	*****	-0.3772
0.850	-0.3060	-0.3925	-0.3198	-0.3337	-0.3385	*****	*****	*****	*****	-0.3385
0.875	*****	-0.4227	-0.3760	-0.3821	-0.3133	*****	*****	*****	*****	-0.3133
0.900	-0.3133	-0.4498	-0.4334	-0.4493	-0.3270	*****	*****	*****	*****	-0.3270
0.925	*****	-0.4736	-0.4887	-0.5229	-0.3321	*****	*****	*****	*****	-0.3321
0.950	-0.3312	-0.4854	-0.5530	-0.6005	-0.6752	*****	*****	*****	*****	-0.6752
0.975	*****	-0.5738	-0.6113	-0.6762	-0.7730	*****	*****	*****	*****	-0.7730
1.000	-0.2368	-0.5763	-0.5710	-0.8694	-0.8400	*****	*****	*****	*****	-0.8400
-0.200	$C_{p,l}$	$C_{p,l}$	$C_{p,l}$	$C_{p,l}$	$C_{p,l}$	$C_{p,l}$	$C_{p,l}$	$C_{p,l}$	$C_{p,l}$	$C_{p,l}$
-0.400	0.1063	0.1099	0.1802	*****	-0.6319	*****	*****	*****	*****	-0.6319
-0.600	0.0952	0.1172	0.1462	-0.0098	-0.6636	*****	*****	*****	*****	-0.6636
-0.700	0.1021	0.1164	0.1278	0.0181	-0.6544	*****	*****	*****	*****	-0.6544
-0.800	0.1220	0.1118	0.1300	0.0301	-0.6397	*****	*****	*****	*****	-0.6397
-0.850	0.1531	0.1223	0.1270	0.0489	-0.5884	*****	*****	*****	*****	-0.5884
-0.900	0.1777	0.1453	0.1328	0.0555	-0.5906	*****	*****	*****	*****	-0.5906
-0.950	0.2286	0.2119	0.1994	0.1260	-0.2230	*****	*****	*****	*****	-0.2230
-0.975	*****	0.2136	0.2077	0.1535	-0.0713	*****	*****	*****	*****	-0.0713
-1.000	-0.2228	-0.5408	-0.7762	-0.8120	-0.7315	*****	*****	*****	*****	-0.7315

Medium Radius L.E.
 Run No. = 9, Point No. = 178
 $C_N = 0.260$, $C_m = -0.0508$
 $\alpha = 6.2^\circ$, $M_\infty = 0.898$
 $R_{mac} = 6.0 \times 10^6$

Leading Edge Pressures

● starboard
 ○ port

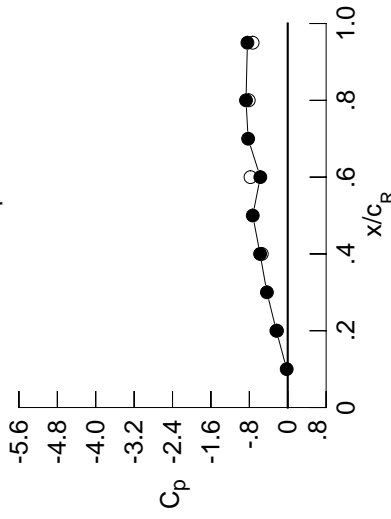

x/c_R	starb'd C_p	port C_p
0.10	-0.0215	*****
0.20	-0.2368	-0.2228
0.30	-0.4337	*****
0.40	-0.5763	-0.5408
0.50	-0.7286	*****
0.60	-0.5710	-0.7762
0.70	-0.8248	*****
0.80	-0.8694	-0.8120
0.90	*****	*****
0.95	-0.8400	-0.7315

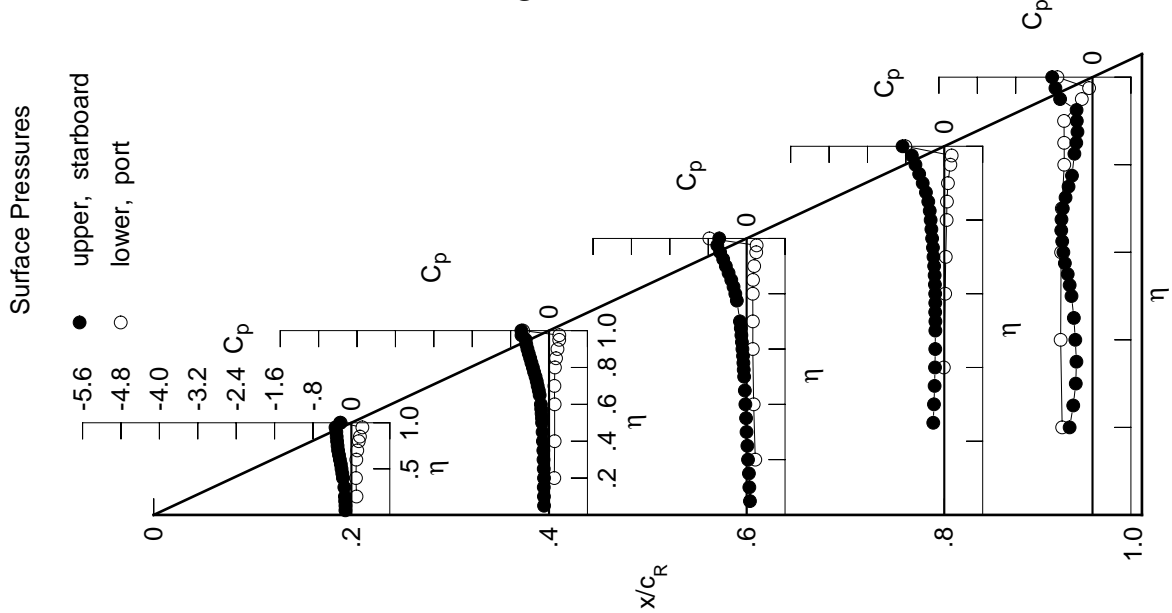

Table F4. Continued.

η	$x/c_R = .2$		$x/c_R = .4$		$x/c_R = .6$		$x/c_R = .8$		$x/c_R = .95$	
	$C_{p,u}$	$C_{p,u}$	$C_{p,u}$	$C_{p,u}$	$C_{p,u}$	$C_{p,u}$	$C_{p,u}$	$C_{p,u}$	$C_{p,u}$	$C_{p,u}$
0.050	-0.1416	-0.1220	0.0568	*****	*****	*****	*****	*****	*****	*****
0.100	-0.1417	-0.1221	0.0447	*****	*****	*****	*****	*****	*****	*****
0.150	-0.1469	-0.1258	0.0349	*****	*****	*****	*****	*****	*****	*****
0.200	-0.1552	-0.1245	0.0160	*****	*****	*****	*****	*****	*****	-0.3828
0.250	*****	-0.1292	0.0028	-0.2486	-0.3194	-0.3436	-0.3194	-0.3436	-0.3194	-0.3436
0.300	-0.1655	-0.1360	-0.2316	-0.2184	-0.3048	-0.3048	-0.3048	-0.3048	-0.3048	-0.3048
0.350	*****	-0.1395	-0.0239	-0.2108	-0.3017	-0.3017	-0.3017	-0.3017	-0.3017	-0.3017
0.400	-0.1969	-0.1471	-0.0412	-0.2108	-0.3017	-0.3017	-0.3017	-0.3017	-0.3017	-0.3017
0.450	-0.2121	-0.1558	-0.0520	-0.2077	-0.3459	-0.3459	-0.3459	-0.3459	-0.3459	-0.3459
0.500	-0.2298	-0.1675	-0.0709	-0.2046	-0.4269	-0.4269	-0.4269	-0.4269	-0.4269	-0.4269
0.525	*****	-0.1743	-0.0787	-0.2024	-0.5024	-0.5024	-0.5024	-0.5024	-0.5024	-0.5024
0.550	-0.2460	-0.1843	-0.0893	-0.2073	-0.5736	-0.5736	-0.5736	-0.5736	-0.5736	-0.5736
0.575	*****	-0.1907	-0.0963	-0.2075	-0.6356	-0.6356	-0.6356	-0.6356	-0.6356	-0.6356
0.600	-0.2695	-0.2014	-0.1157	-0.2097	-0.6718	-0.6718	-0.6718	-0.6718	-0.6718	-0.6718
0.625	*****	*****	-0.1296	-0.2217	-0.6820	-0.6820	-0.6820	-0.6820	-0.6820	-0.6820
0.650	-0.2935	-0.2311	-0.1473	-0.2387	-0.6336	-0.6336	-0.6336	-0.6336	-0.6336	-0.6336
0.675	*****	-0.2471	-0.1637	-0.2576	-0.5148	-0.5148	-0.5148	-0.5148	-0.5148	-0.5148
0.700	-0.3146	-0.2708	-0.1861	-0.2796	-0.4504	-0.4504	-0.4504	-0.4504	-0.4504	-0.4504
0.725	*****	-0.2946	*****	-0.3020	-0.4362	-0.4362	-0.4362	-0.4362	-0.4362	-0.4362
0.750	-0.3291	-0.3211	*****	-0.3122	-0.4660	-0.4660	-0.4660	-0.4660	-0.4660	-0.4660
0.775	*****	-0.3550	-0.2514	-0.3102	-0.5663	-0.5663	-0.5663	-0.5663	-0.5663	-0.5663
0.800	-0.3477	-0.3862	-0.2781	-0.3289	*****	*****	*****	*****	*****	*****
0.825	*****	-0.4222	-0.3069	-0.3563	-0.8153	-0.8153	-0.8153	-0.8153	-0.8153	-0.8153
0.850	-0.3720	-0.4572	-0.3532	-0.4011	-0.8357	-0.8357	-0.8357	-0.8357	-0.8357	-0.8357
0.875	*****	-0.4952	-0.4092	-0.4732	-0.8409	-0.8409	-0.8409	-0.8409	-0.8409	-0.8409
0.900	-0.3889	-0.5307	-0.4793	-0.6031	-0.7571	-0.7571	-0.7571	-0.7571	-0.7571	-0.7571
0.925	*****	-0.5725	-0.5500	-0.7095	-0.6321	-0.6321	-0.6321	-0.6321	-0.6321	-0.6321
0.950	-0.4277	-0.6031	-0.6480	-0.7788	-0.5832	-0.5832	-0.5832	-0.5832	-0.5832	-0.5832
0.975	*****	-0.6616	-0.8837	-0.8272	-0.6249	-0.6249	-0.6249	-0.6249	-0.6249	-0.6249
1.000	-0.3932	-0.7834	-0.6924	-0.9732	-0.7215	-0.7215	-0.7215	-0.7215	-0.7215	-0.7215
-0.200	$C_{p,l}$	0.1285	0.1334	0.1967	*****	-0.6244	-0.6244	-0.6244	-0.6244	-0.6244
-0.400	$C_{p,l}$	0.1203	0.1390	0.1615	0.0081	-0.6583	-0.6583	-0.6583	-0.6583	-0.6583
-0.600	$C_{p,l}$	0.1293	0.1402	0.1488	0.0358	-0.6435	-0.6435	-0.6435	-0.6435	-0.6435
-0.700	$C_{p,l}$	0.1506	0.1377	0.1497	0.0495	-0.6267	-0.6267	-0.6267	-0.6267	-0.6267
-0.800	$C_{p,l}$	0.1825	0.1520	0.1506	0.0707	-0.5720	-0.5720	-0.5720	-0.5720	-0.5720
-0.850	$C_{p,l}$	0.2045	0.1750	0.1597	0.0792	-0.5711	-0.5711	-0.5711	-0.5711	-0.5711
-0.900	$C_{p,l}$	*****	0.2021	0.1824	0.1018	-0.5638	-0.5638	-0.5638	-0.5638	-0.5638
-0.950	$C_{p,l}$	0.2390	0.2270	0.2148	0.1475	-0.2028	-0.2028	-0.2028	-0.2028	-0.2028
-0.975	$C_{p,l}$	*****	0.2097	0.2061	0.1606	-0.0542	-0.0542	-0.0542	-0.0542	-0.0542
-1.000	$C_{p,l}$	-0.3818	-0.7485	-0.9296	-0.9296	-0.6369	-0.6369	-0.6369	-0.6369	-0.6369

Medium Radius L.E.

Run No. = 9, Point No. = 179

$C_N = 0.316$, $C_m = -0.0648$

$\alpha = 7.3^\circ$, $M_\infty = 0.898$

$R_{mac} = 6.0 \times 10^6$

Leading Edge Pressures

● starboard
○ port

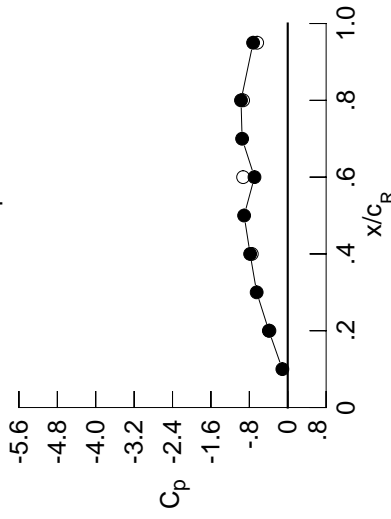

x/c_R	starb'd C_p	port C_p
0.10	-0.1123	*****
0.20	-0.3932	-0.3818
0.30	-0.6469	*****
0.40	-0.7834	-0.7485
0.50	-0.9086	*****
0.60	-0.6924	-0.9296
0.70	-0.9505	*****
0.80	-0.9732	-0.9296
0.90	*****	*****
0.95	-0.7215	-0.6369

Surface Pressures

● upper, starboard
○ lower, port

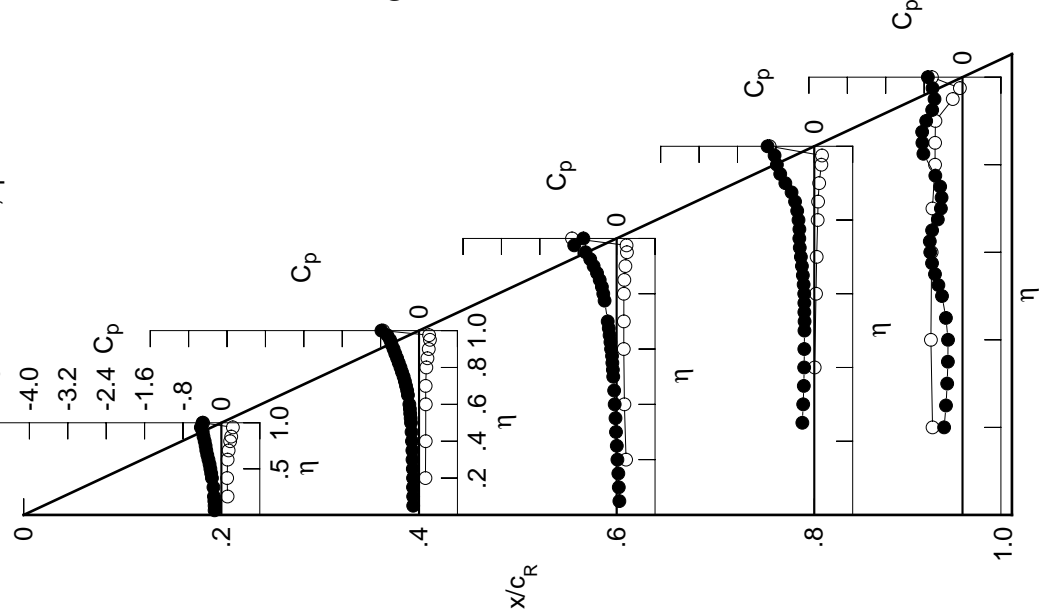
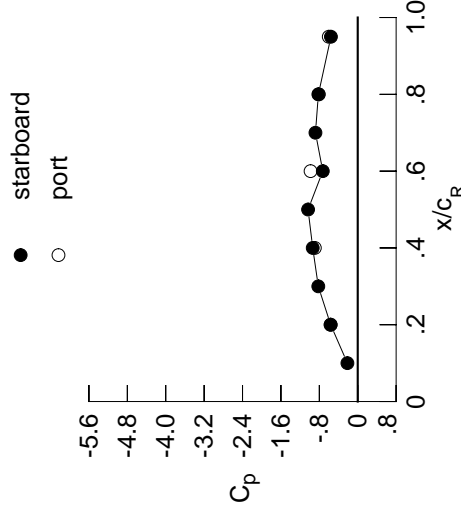

Table F4. Continued.

η	$x/c_R = .2$		$x/c_R = .4$		$x/c_R = .6$		$x/c_R = .8$		$x/c_R = .95$	
	$C_{p,u}$	$C_{p,u}$	$C_{p,u}$	$C_{p,u}$	$C_{p,u}$	$C_{p,u}$	$C_{p,u}$	$C_{p,u}$	$C_{p,u}$	$C_{p,u}$
0.050	-0.1531	-0.1394	0.0435	*****	*****	*****	*****	*****	*****	*****
0.100	-0.1549	-0.1411	0.0292	*****	*****	*****	*****	*****	*****	*****
0.150	-0.1608	-0.1468	0.0157	*****	*****	*****	*****	*****	*****	*****
0.200	-0.1685	-0.1396	0.0030	*****	*****	*****	*****	*****	*****	-0.3277
0.250	*****	-0.1500	-0.0111	-0.2664	-0.2847	*****	*****	*****	*****	-0.2847
0.300	-0.1820	-0.1526	-0.0302	-0.2527	-0.2326	*****	*****	*****	*****	-0.2326
0.350	*****	-0.1608	-0.0435	-0.2388	-0.2456	*****	*****	*****	*****	-0.2456
0.400	-0.2136	-0.1675	-0.0576	-0.2292	-0.2741	*****	*****	*****	*****	-0.2741
0.450	-0.2314	-0.1792	-0.0702	-0.2264	-0.3370	*****	*****	*****	*****	-0.3370
0.500	-0.2511	-0.1957	-0.0924	-0.2220	-0.4412	*****	*****	*****	*****	-0.4412
0.525	*****	-0.2017	-0.1028	-0.2243	-0.3982	*****	*****	*****	*****	-0.3982
0.550	-0.2706	-0.2141	-0.1169	-0.2397	-0.3297	*****	*****	*****	*****	-0.3297
0.575	*****	-0.2236	-0.1322	-0.2623	-0.3467	*****	*****	*****	*****	-0.3467
0.600	-0.2974	-0.2368	-0.1593	-0.2707	-0.4255	*****	*****	*****	*****	-0.4255
0.625	*****	*****	-0.1797	-0.2560	-0.5698	*****	*****	*****	*****	-0.5698
0.650	-0.3252	-0.2658	-0.2036	-0.2461	-0.7093	*****	*****	*****	*****	-0.7093
0.675	*****	-0.2882	-0.2261	-0.2402	-0.7448	*****	*****	*****	*****	-0.7448
0.700	-0.3520	-0.3080	-0.2413	-0.2356	-0.7439	*****	*****	*****	*****	-0.7439
0.725	*****	-0.3312	*****	-0.2270	-0.7301	*****	*****	*****	*****	-0.7301
0.750	-0.3797	-0.3578	*****	-0.2088	-0.8055	*****	*****	*****	*****	-0.8055
0.775	*****	-0.3920	-0.2680	-0.2098	-1.0256	*****	*****	*****	*****	-1.0256
0.800	-0.4049	-0.4289	-0.2903	-0.5276	*****	*****	*****	*****	*****	*****
0.825	*****	-0.4679	-0.3414	-0.8431	-1.0323	*****	*****	*****	*****	-1.0323
0.850	-0.4243	-0.5091	-0.4503	-0.8774	-0.8390	*****	*****	*****	*****	-0.8390
0.875	*****	-0.5565	-0.6278	-0.8307	-0.7225	*****	*****	*****	*****	-0.7225
0.900	-0.4415	-0.6024	-0.7947	-0.7809	-0.6674	*****	*****	*****	*****	-0.6674
0.925	*****	-0.6469	-0.8892	-0.7243	-0.6466	*****	*****	*****	*****	-0.6466
0.950	-0.5356	-0.6906	-0.9150	-0.6985	-0.5708	*****	*****	*****	*****	-0.5708
0.975	*****	-1.1068	-0.9108	-0.6940	-0.5193	*****	*****	*****	*****	-0.5193
1.000	-0.5641	-0.9374	-0.7276	-0.8197	-0.5582	*****	*****	*****	*****	-0.5582
-0.200	$C_{p,l}$	$C_{p,l}$	$C_{p,l}$	$C_{p,l}$	$C_{p,l}$	$C_{p,l}$	$C_{p,l}$	$C_{p,l}$	$C_{p,l}$	$C_{p,l}$
-0.400	0.1555	0.1580	0.2156	*****	*****	*****	*****	*****	*****	-0.6165
-0.600	0.1491	0.1661	0.1832	0.0267	0.6529	*****	*****	*****	*****	-0.6529
-0.700	0.1574	0.1689	0.1696	0.0556	-0.6315	*****	*****	*****	*****	-0.6315
-0.800	0.1782	0.1680	0.1762	0.0697	-0.6165	*****	*****	*****	*****	-0.6165
-0.850	0.2089	0.1835	0.1779	0.0913	-0.5597	*****	*****	*****	*****	-0.5597
-0.900	0.2284	0.2029	0.1887	0.1014	-0.5602	*****	*****	*****	*****	-0.5602
-0.950	0.2437	0.2255	0.2080	0.1253	-0.5534	*****	*****	*****	*****	-0.5534
-0.975	0.2437	0.2392	0.2314	0.1613	-0.2021	*****	*****	*****	*****	-0.2021
-1.000	0.2021	0.2080	0.1641	-0.0637	*****	*****	*****	*****	*****	-0.0637
-1.000	-0.5655	-0.8939	-0.9828	-0.8100	-0.6035	*****	*****	*****	*****	-0.6035

Medium Radius L.E.
 Run No. = 9, Point No. = 180
 $C_N = 0.378$, $C_m = -0.0798$
 $\alpha = 8.3^\circ$, $M_\infty = 0.898$
 $R_{mac} = 6.0 \times 10^6$

Leading Edge Pressures



x/c_R	starb'd C_p	port C_p
0.10	-0.2148	*****
0.20	-0.5641	-0.5655
0.30	-0.8216	*****
0.40	-0.9374	-0.8939
0.50	-1.0348	*****
0.60	-0.7276	-0.9828
0.70	-0.8806	*****
0.80	-0.8197	-0.8100
0.90	*****	*****
0.95	-0.5582	-0.6035

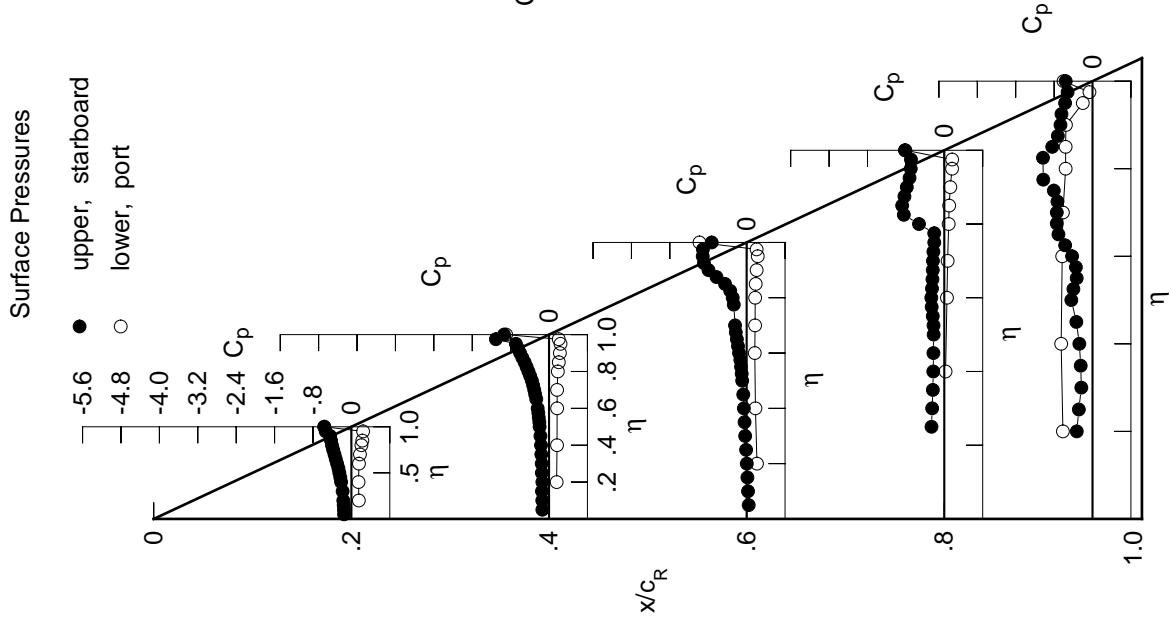

Table F4. Continued.

η	x/c_R .2	x/c_R .4	x/c_R .6	x/c_R .8	x/c_R .95
	$C_{p,u}$	$C_{p,u}$	$C_{p,u}$	$C_{p,u}$	$C_{p,u}$
0.050	-0.1687	-0.1605	0.0284	*****	*****
0.100	-0.1693	-0.1603	0.0159	*****	*****
0.150	-0.1796	-0.1670	0.0036	*****	*****
0.200	-0.1835	-0.1593	-0.0113	*****	-0.2775
0.250	*****	-0.1711	-0.0289	-0.2889	-0.2316
0.300	-0.2012	-0.1752	-0.0466	-0.2734	-0.2146
0.350	*****	-0.1835	-0.0554	-0.2574	-0.2480
0.400	-0.2350	-0.1933	-0.0721	-0.2477	-0.3166
0.450	-0.2557	-0.2080	-0.0867	-0.2576	-0.3080
0.500	-0.2761	-0.2283	-0.1207	-0.2728	-0.3470
0.525	*****	-0.2414	-0.1481	-0.2560	-0.4105
0.550	-0.2985	-0.2556	-0.1775	-0.2516	-0.5113
0.575	*****	-0.2680	-0.1835	-0.2434	-0.6314
0.600	-0.3266	-0.2797	-0.1766	-0.2382	-0.7046
0.625	*****	*****	-0.1713	-0.2348	-0.7426
0.650	-0.3626	-0.3158	-0.1723	-0.2288	-0.7596
0.675	*****	-0.3353	-0.1755	-0.2186	-0.7684
0.700	-0.3980	-0.3517	-0.1772	-0.2119	-0.8520
0.725	*****	-0.3768	*****	-0.2565	-1.0021
0.750	-0.4253	-0.4019	*****	-0.5066	-1.0862
0.775	*****	-0.4359	-0.2269	-0.8332	-0.9138
0.800	-0.4545	-0.4707	-0.7363	-0.9556	*****
0.825	*****	-0.5090	-0.9512	-0.9741	-0.6368
0.850	-0.4896	-0.5533	-0.9638	-0.8792	-0.5990
0.875	*****	-0.6189	-0.9438	-0.7536	-0.5916
0.900	-0.5272	-0.7248	-0.9029	-0.7150	-0.6168
0.925	*****	-0.8638	-0.8524	-0.6813	-0.6432
0.950	-0.5867	-1.0089	-0.8257	-0.6907	-0.5757
0.975	*****	-1.1613	-0.8121	-0.6733	-0.5168
1.000	-0.7126	-1.0424	-0.7062	-0.7637	-0.5115
	$C_{p,l}$	$C_{p,l}$	$C_{p,l}$	$C_{p,l}$	$C_{p,l}$
-0.200	0.1799	0.1814	0.2329	*****	-0.6104
-0.400	0.1764	0.1879	0.2028	0.0399	-0.6462
-0.600	0.1892	0.1946	0.1899	0.0701	-0.6261
-0.700	0.2073	0.1939	0.1957	0.0852	-0.6056
-0.800	0.2360	0.2105	0.2004	0.1096	-0.5506
-0.850	0.2530	0.2286	0.2117	0.1181	-0.5494
-0.900	*****	0.2475	0.2299	0.1415	-0.5405
-0.950	0.2486	0.2500	0.2422	0.1710	-0.1990
-0.975	*****	0.1958	0.2057	0.1632	-0.0682
-1.000	-0.7281	-0.9906	-0.9032	-0.7380	-0.5695

Medium Radius L.E.
 Run No. = 9, Point No. = 181
 $C_N = 0.435$, $C_m = -0.0910$
 $\alpha = 9.3^\circ$, $M_\infty = 0.897$
 $R_{mac} = 6.0 \times 10^6$

Leading Edge Pressures

- starboard
- port

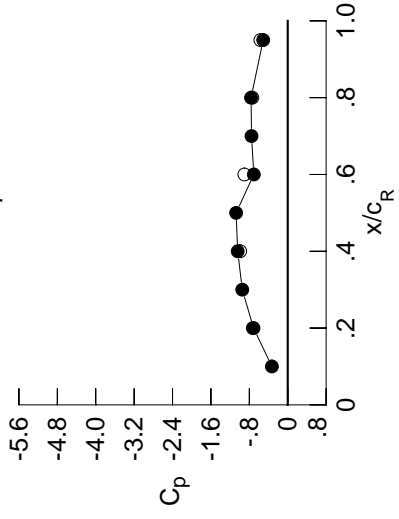

x/c_R	starb'd C_p	port C_p
0.10	-0.3294	*****
0.20	-0.7126	-0.7281
0.30	-0.9469	*****
0.40	-1.0424	-0.9906
0.50	-1.0756	*****
0.60	-0.7062	-0.9032
0.70	-0.7545	*****
0.80	-0.7637	-0.7380
0.90	*****	*****
0.95	-0.5115	-0.5695

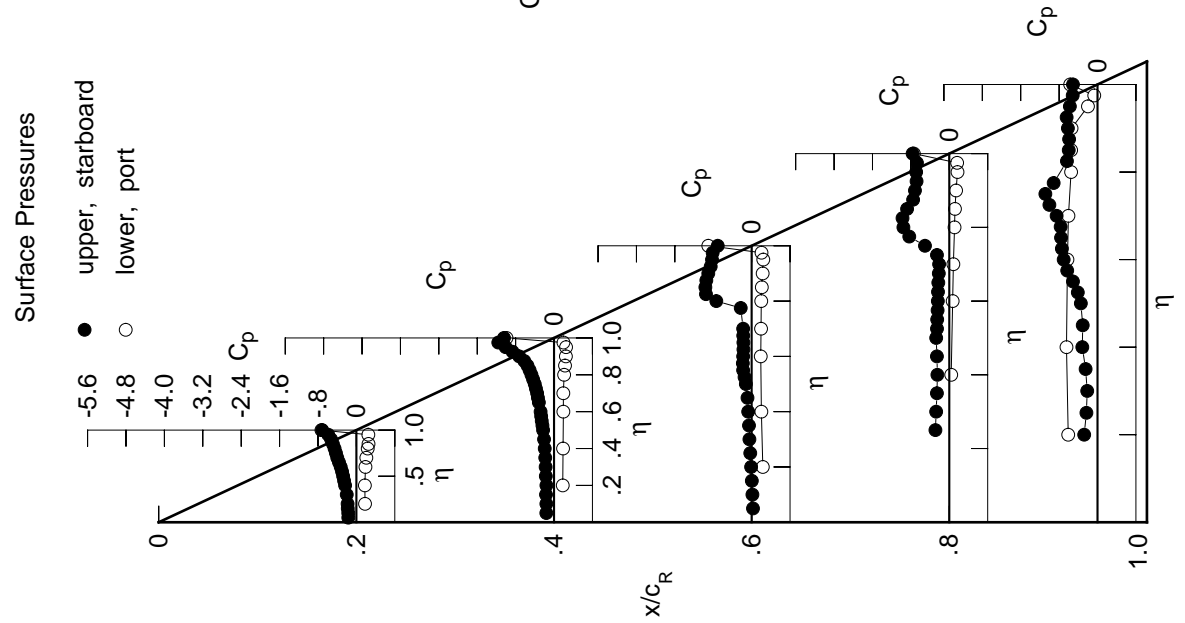
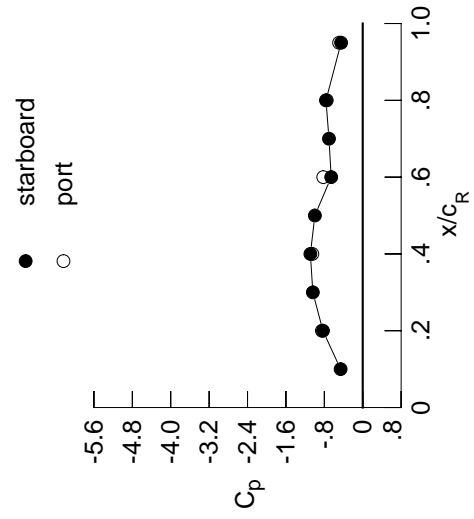

Table F4. Continued.

η	$x/c_R = .2$		$x/c_R = .4$		$x/c_R = .6$		$x/c_R = .8$		$x/c_R = .95$	
	$C_{p,u}$	$C_{p,u}$	$C_{p,u}$	$C_{p,u}$	$C_{p,u}$	$C_{p,u}$	$C_{p,u}$	$C_{p,u}$	$C_{p,u}$	$C_{p,u}$
0.050	-0.1838	-0.1850	0.0073	*****	*****	*****	*****	*****	*****	*****
0.100	-0.1886	-0.1864	-0.0023	*****	*****	*****	*****	*****	*****	*****
0.150	-0.1965	-0.1904	-0.0167	*****	*****	*****	*****	*****	*****	*****
0.200	-0.2048	-0.1884	-0.0341	*****	*****	*****	*****	*****	*****	*****
0.250	*****	-0.1970	-0.0497	-0.3101	-0.2347	*****	*****	*****	*****	*****
0.300	-0.2226	-0.2020	-0.0663	-0.2913	-0.2611	*****	*****	*****	*****	*****
0.350	*****	-0.2087	-0.0809	-0.2814	-0.2769	*****	*****	*****	*****	*****
0.400	-0.2597	-0.2252	-0.1085	-0.2925	-0.2471	*****	*****	*****	*****	*****
0.450	-0.2801	-0.2492	-0.1525	-0.2670	-0.2965	*****	*****	*****	*****	*****
0.500	-0.3031	-0.2751	-0.1428	-0.2604	-0.4043	*****	*****	*****	*****	*****
0.525	*****	-0.2862	-0.1442	-0.2551	-0.5183	*****	*****	*****	*****	*****
0.550	-0.3308	-0.3033	-0.1454	-0.2537	-0.6245	*****	*****	*****	*****	*****
0.575	*****	-0.3165	-0.1448	-0.2431	-0.7148	*****	*****	*****	*****	*****
0.600	-0.3638	-0.3200	-0.1506	-0.2360	-0.7548	*****	*****	*****	*****	*****
0.625	*****	*****	-0.1536	-0.2301	-0.7791	*****	*****	*****	*****	*****
0.650	-0.4007	-0.3316	-0.1488	-0.2366	-0.8301	*****	*****	*****	*****	*****
0.675	*****	-0.3413	-0.1392	-0.2867	-0.9167	*****	*****	*****	*****	*****
0.700	-0.4354	-0.3540	-0.1413	-0.4561	-1.0215	*****	*****	*****	*****	*****
0.725	*****	-0.3734	*****	-0.7274	-0.9206	*****	*****	*****	*****	*****
0.750	-0.4681	-0.4089	*****	-0.9523	-0.6998	*****	*****	*****	*****	*****
0.775	*****	-0.4914	-1.0534	-1.0532	-0.6303	*****	*****	*****	*****	*****
0.800	-0.5082	-0.6420	-1.0759	-0.9821	*****	*****	*****	*****	*****	*****
0.825	*****	-0.7978	-1.0502	-0.8135	-0.5841	*****	*****	*****	*****	*****
0.850	-0.5538	-0.9088	-0.9982	-0.7568	-0.5748	*****	*****	*****	*****	*****
0.875	*****	-0.9855	-0.9302	-0.7542	-0.5890	*****	*****	*****	*****	*****
0.900	-0.6016	-1.0238	-0.8392	-0.7094	-0.6075	*****	*****	*****	*****	*****
0.925	*****	-1.0295	-0.7906	-0.6914	-0.6038	*****	*****	*****	*****	*****
0.950	-0.7170	-1.0285	-0.7573	-0.7238	-0.5312	*****	*****	*****	*****	*****
0.975	*****	-1.0318	-0.7394	-0.7034	-0.4607	*****	*****	*****	*****	*****
1.000	-0.8292	-1.0907	-0.6569	-0.7656	-0.4508	*****	*****	*****	*****	*****
-0.200	$C_{p,l}$	$C_{p,l}$	$C_{p,l}$	$C_{p,l}$	$C_{p,l}$	$C_{p,l}$	$C_{p,l}$	$C_{p,l}$	$C_{p,l}$	$C_{p,l}$
-0.400	0.2091	0.2062	0.2518	*****	-0.5988	*****	*****	*****	*****	*****
-0.600	0.2067	0.2148	0.2214	0.0571	-0.6383	*****	*****	*****	*****	*****
-0.700	0.2207	0.2189	0.2140	0.0860	-0.6136	*****	*****	*****	*****	*****
-0.800	0.2399	0.2222	0.2163	0.1008	-0.5954	*****	*****	*****	*****	*****
-0.850	0.2641	0.2396	0.2211	0.1242	-0.5374	*****	*****	*****	*****	*****
-0.900	0.2773	0.2558	0.2318	0.1349	-0.5350	*****	*****	*****	*****	*****
-0.950	*****	0.2700	0.2492	0.1566	-0.5171	*****	*****	*****	*****	*****
-0.975	0.2511	0.2582	0.2509	0.1816	-0.1903	*****	*****	*****	*****	*****
-1.000	*****	0.1883	0.2007	0.1592	-0.0616	*****	*****	*****	*****	*****
	-0.8503	-1.0493	-0.8224	-0.7495	-0.4920	*****	*****	*****	*****	*****

Medium Radius L.E.
 Run No. = 9, Point No. = 182
 $C_N = 0.494$, $C_m = -0.1021$
 $\alpha = 10.4^\circ$, $M_\infty = 0.899$
 $R_{mac} = 6.0 \times 10^6$

Leading Edge Pressures



x/c_R	starb'd C_p	port C_p
0.10	-0.4610	*****
0.20	-0.8292	-0.8503
0.30	-1.0394	*****
0.40	-1.0907	-1.0493
0.50	-0.9972	*****
0.60	-0.6569	-0.8224
0.70	-0.7033	*****
0.80	-0.7656	-0.7495
0.90	*****	*****
0.95	-0.4508	-0.4920

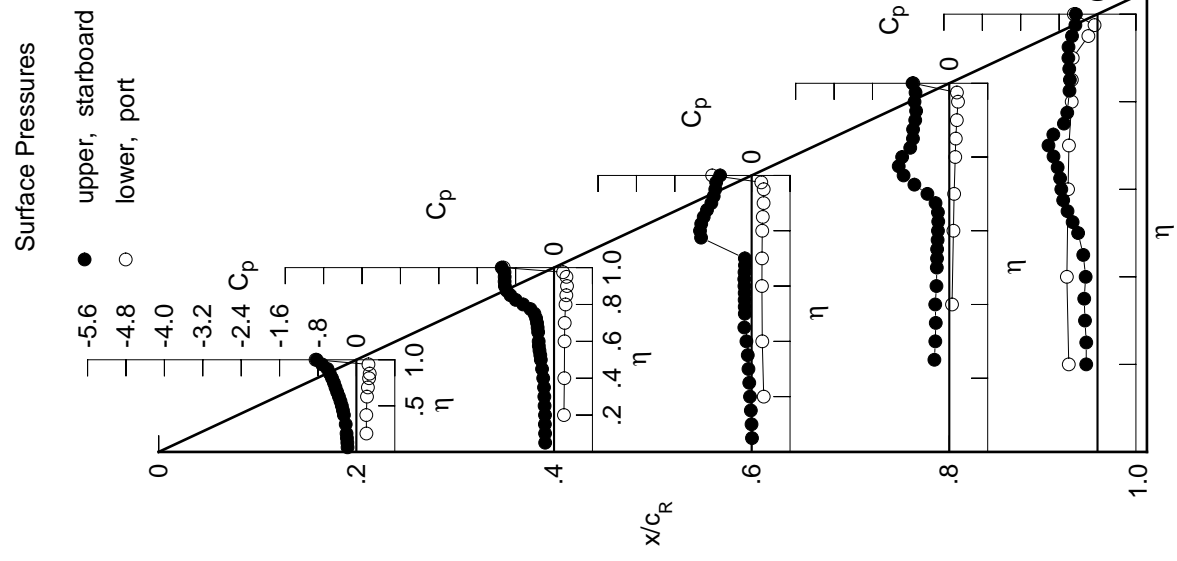

Table F4. Continued.

η	$x/c_R = .2$		$x/c_R = .4$		$x/c_R = .6$		$x/c_R = .8$		$x/c_R = .95$	
	$C_{p,u}$	$C_{p,u}$	$C_{p,u}$	$C_{p,u}$	$C_{p,u}$	$C_{p,u}$	$C_{p,u}$	$C_{p,u}$	$C_{p,u}$	$C_{p,u}$
0.050	-0.2013	-0.2117	-0.0109	*****	*****	*****	*****	*****	*****	*****
0.100	-0.2058	-0.2152	-0.0216	*****	*****	*****	*****	*****	*****	*****
0.150	-0.2165	-0.2166	-0.0375	*****	*****	*****	*****	*****	*****	*****
0.200	-0.2211	-0.2164	-0.0542	*****	*****	*****	*****	*****	*****	-0.2620
0.250	*****	-0.2217	-0.0703	-0.3287	-0.3287	-0.2641	*****	*****	*****	-0.2641
0.300	-0.2468	-0.2279	-0.0891	-0.3143	-0.3143	-0.2540	*****	*****	*****	-0.2540
0.350	*****	-0.2386	-0.1240	-0.3151	-0.2300	*****	*****	*****	*****	-0.2300
0.400	-0.2871	-0.2659	-0.1414	-0.2894	-0.2469	*****	*****	*****	*****	-0.2469
0.450	-0.3104	-0.2994	-0.1321	-0.2822	-0.3102	*****	*****	*****	*****	-0.3102
0.500	-0.3345	-0.3081	-0.1435	-0.2708	-0.4835	*****	*****	*****	*****	-0.4835
0.525	*****	-0.2980	-0.1462	-0.2661	-0.6293	*****	*****	*****	*****	-0.6293
0.550	-0.3613	-0.2963	-0.1517	-0.2609	-0.7227	*****	*****	*****	*****	-0.7227
0.575	*****	-0.2950	-0.1475	-0.2547	-0.7775	*****	*****	*****	*****	-0.7775
0.600	-0.3932	-0.2943	-0.1534	-0.2589	-0.8137	*****	*****	*****	*****	-0.8137
0.625	*****	*****	-0.1497	-0.2932	-0.8778	*****	*****	*****	*****	-0.8778
0.650	-0.4314	-0.3047	-0.1713	-0.3817	-0.9778	*****	*****	*****	*****	-0.9778
0.675	*****	-0.3022	-0.2760	-0.5640	-1.0704	*****	*****	*****	*****	-1.0704
0.700	-0.4710	-0.2849	-0.5740	-0.8033	-0.8584	*****	*****	*****	*****	-0.8584
0.725	*****	-0.3933	*****	-1.0059	-0.7272	*****	*****	*****	*****	-0.7272
0.750	-0.5105	-0.8238	*****	-1.1301	-0.6572	*****	*****	*****	*****	-0.6572
0.775	*****	-1.0103	-1.1337	-1.0144	-0.6041	*****	*****	*****	*****	-0.6041
0.800	-0.5565	-1.0657	-1.1047	-0.8199	*****	*****	*****	*****	*****	-0.8199
0.825	*****	-1.0793	-1.0607	-0.7789	-0.5775	*****	*****	*****	*****	-0.5775
0.850	-0.6084	-1.0705	-0.9637	-0.7771	-0.5603	*****	*****	*****	*****	-0.5603
0.875	*****	-1.0574	-0.8778	-0.7705	-0.5705	*****	*****	*****	*****	-0.5705
0.900	-0.6810	-1.0344	-0.8325	-0.7209	-0.5756	*****	*****	*****	*****	-0.5756
0.925	*****	-1.0077	-0.7830	-0.7184	-0.5522	*****	*****	*****	*****	-0.5522
0.950	-1.0585	-0.9901	-0.7520	-0.7398	-0.4854	*****	*****	*****	*****	-0.4854
0.975	*****	-0.9863	-0.7360	-0.7208	-0.4224	*****	*****	*****	*****	-0.4224
1.000	-0.9190	-1.0812	-0.6527	-0.7620	-0.4079	*****	*****	*****	*****	-0.4079
	$C_{p,l}$	$C_{p,l}$	$C_{p,l}$	$C_{p,l}$	$C_{p,l}$	$C_{p,l}$	$C_{p,l}$	$C_{p,l}$	$C_{p,l}$	$C_{p,l}$
-0.200	0.2353	0.2257	0.2651	*****	-0.5937	*****	*****	*****	*****	-0.5937
-0.400	0.2341	0.2356	0.2344	0.0700	-0.6306	*****	*****	*****	*****	-0.6306
-0.600	0.2495	0.2426	0.2261	0.0966	-0.6059	*****	*****	*****	*****	-0.6059
-0.700	0.2705	0.2469	0.2333	0.1148	-0.5861	*****	*****	*****	*****	-0.5861
-0.800	0.2927	0.2630	0.2402	0.1366	-0.5278	*****	*****	*****	*****	-0.5278
-0.850	0.3011	0.2805	0.2507	0.1492	-0.5224	*****	*****	*****	*****	-0.5224
-0.900	*****	0.2907	0.2648	0.1704	-0.4997	*****	*****	*****	*****	-0.4997
-0.950	0.2550	0.2666	0.2570	0.1871	-0.1806	*****	*****	*****	*****	-0.1806
-0.975	*****	0.1810	0.1930	0.1520	-0.0593	*****	*****	*****	*****	-0.0593
-1.000	-0.9431	-1.0793	-0.8017	-0.7707	-0.4415	*****	*****	*****	*****	-0.4415

Medium Radius L.E.
 Run No. = 9, Point No. = 183
 $C_N = 0.553$, $C_m = -0.1151$
 $\alpha = 11.4^\circ$, $M_\infty = 0.899$
 $R_{mac} = 6.0 \times 10^6$

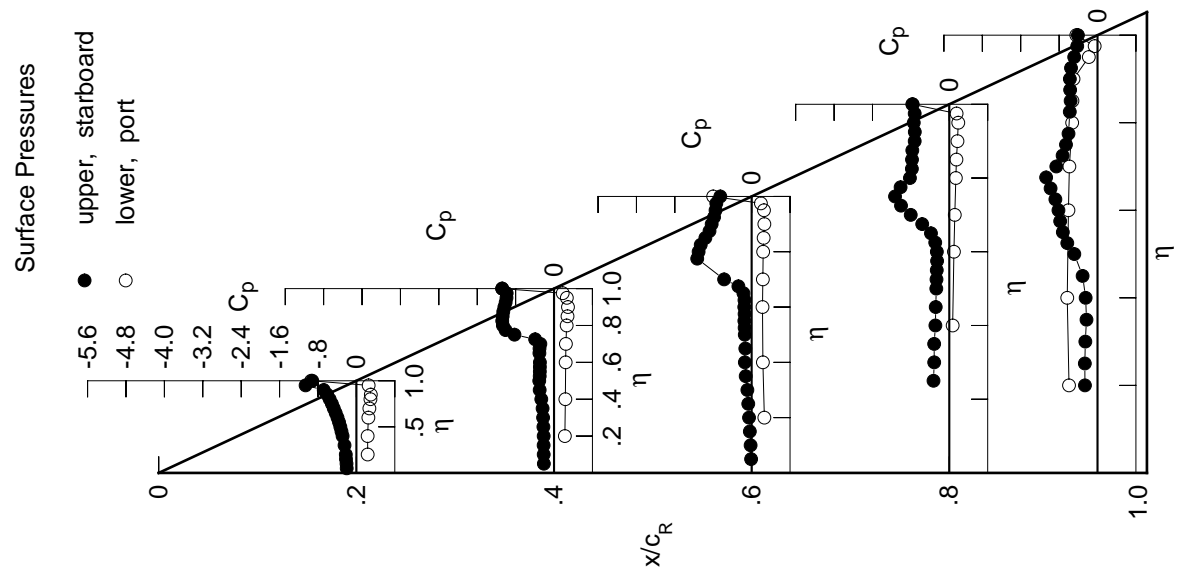
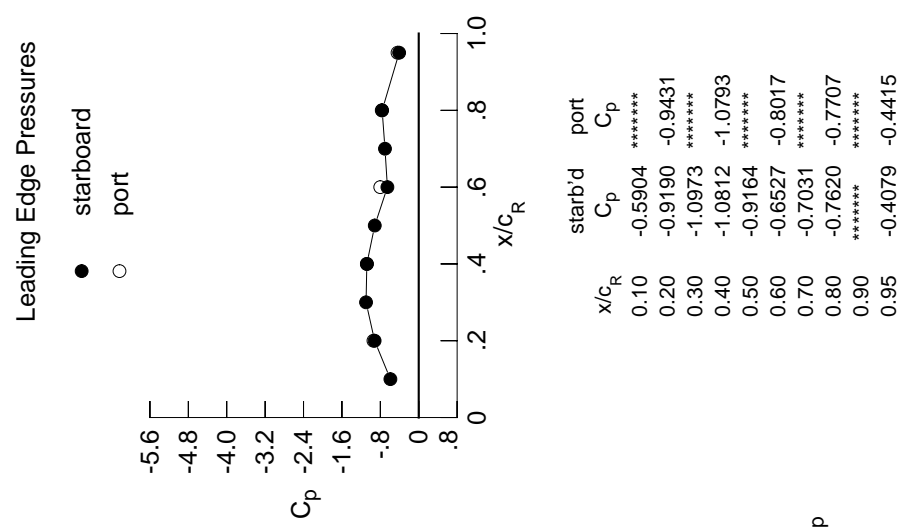
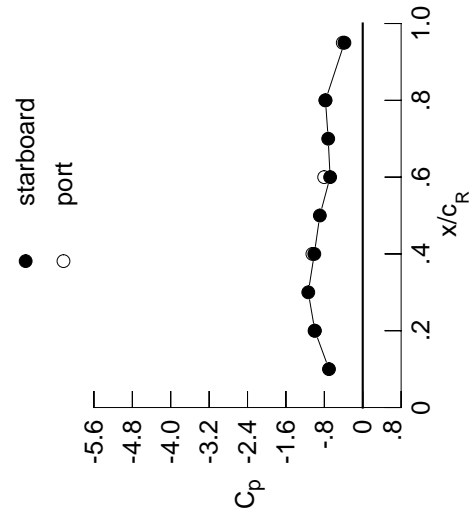

Table F4. Continued.

η	$x/c_R = .2$		$x/c_R = .4$		$x/c_R = .6$		$x/c_R = .8$		$x/c_R = .95$	
	$C_{p,u}$	$C_{p,u}$	$C_{p,u}$	$C_{p,u}$	$C_{p,u}$	$C_{p,u}$	$C_{p,u}$	$C_{p,u}$	$C_{p,u}$	$C_{p,u}$
0.050	-0.2216	-0.2362	-0.0255	*****	*****	*****	*****	*****	*****	*****
0.100	-0.2268	-0.2374	-0.0397	*****	*****	*****	*****	*****	*****	*****
0.150	-0.2363	-0.2405	-0.0556	*****	*****	*****	*****	*****	*****	*****
0.200	-0.2476	-0.2389	-0.0697	*****	*****	*****	*****	*****	*****	*****
0.250	*****	-0.2438	-0.0888	-0.3478	-0.3478	-0.3478	-0.3478	-0.3478	-0.3478	-0.3478
0.300	-0.2736	-0.2538	-0.1299	-0.3458	-0.3458	-0.3458	-0.3458	-0.3458	-0.3458	-0.3458
0.350	*****	-0.2867	-0.1304	-0.3179	-0.2071	*****	*****	*****	*****	*****
0.400	-0.3175	-0.3192	-0.1334	-0.3049	-0.2312	*****	*****	*****	*****	*****
0.450	-0.3375	-0.2937	-0.1343	-0.2964	-0.3341	*****	*****	*****	*****	*****
0.500	-0.3619	-0.2948	-0.1471	-0.2841	-0.5766	*****	*****	*****	*****	*****
0.525	*****	-0.2891	-0.1492	-0.2824	-0.7112	*****	*****	*****	*****	*****
0.550	-0.3881	-0.2929	-0.1515	-0.2842	-0.7753	*****	*****	*****	*****	*****
0.575	*****	-0.2931	-0.1489	-0.2981	-0.8287	*****	*****	*****	*****	*****
0.600	-0.4214	-0.2921	-0.1780	-0.3389	-0.8850	*****	*****	*****	*****	*****
0.625	*****	*****	-0.2377	-0.4419	-0.9752	*****	*****	*****	*****	*****
0.650	-0.4610	-0.2641	-0.4319	-0.6140	-1.0682	*****	*****	*****	*****	*****
0.675	*****	-0.2794	-0.7364	-0.8313	-0.7657	*****	*****	*****	*****	*****
0.700	-0.5031	-0.6127	-1.0042	-1.0304	-0.7148	*****	*****	*****	*****	*****
0.725	*****	-1.0736	*****	-1.1669	-0.6684	*****	*****	*****	*****	*****
0.750	-0.5450	-1.1929	*****	-0.9677	-0.6105	*****	*****	*****	*****	*****
0.775	*****	-1.1905	-1.1538	-0.8493	-0.5806	*****	*****	*****	*****	*****
0.800	-0.6009	-1.1773	-1.0914	-0.8351	*****	*****	*****	*****	*****	*****
0.825	*****	-1.1466	-0.9685	-0.8489	-0.5643	*****	*****	*****	*****	*****
0.850	-0.7358	-1.1030	-0.8916	-0.8503	-0.5531	*****	*****	*****	*****	*****
0.875	*****	-1.0561	-0.8711	-0.7945	-0.5592	*****	*****	*****	*****	*****
0.900	-0.9373	-1.0132	-0.8484	-0.7499	-0.5472	*****	*****	*****	*****	*****
0.925	*****	-0.9801	-0.7983	-0.7547	-0.5142	*****	*****	*****	*****	*****
0.950	-1.1627	-0.9593	-0.7848	-0.7671	-0.4466	*****	*****	*****	*****	*****
0.975	*****	-0.9511	-0.7664	-0.7513	-0.4003	*****	*****	*****	*****	*****
1.000	-0.9973	-1.0090	-0.6795	-0.7761	-0.3812	*****	*****	*****	*****	*****
-0.200	$C_{p,l}$	$C_{p,l}$	$C_{p,l}$	$C_{p,l}$	$C_{p,l}$	$C_{p,l}$	$C_{p,l}$	$C_{p,l}$	$C_{p,l}$	$C_{p,l}$
-0.400	0.2632	0.2489	0.2816	*****	-0.5842	*****	*****	*****	*****	*****
-0.600	0.2618	0.2577	0.2521	0.0841	-0.6237	*****	*****	*****	*****	*****
-0.700	0.2788	0.2630	0.2433	0.1115	-0.5960	*****	*****	*****	*****	*****
-0.800	0.2982	0.2698	0.2491	0.1286	-0.5777	*****	*****	*****	*****	*****
-0.850	0.3165	0.2858	0.2563	0.1507	-0.5188	*****	*****	*****	*****	*****
-0.900	0.3220	0.3003	0.2656	0.1633	-0.5118	*****	*****	*****	*****	*****
-0.950	0.2564	0.2696	0.2760	0.1827	-0.4855	*****	*****	*****	*****	*****
-0.975	*****	0.1709	0.1802	0.1435	-0.0596	*****	*****	*****	*****	*****
-1.000	-1.0031	-1.0490	-0.8035	-0.7780	-0.4162	*****	*****	*****	*****	*****

Medium Radius L.E.
 Run No. = 9, Point No. = 184
 $C_N = 0.610$, $C_m = -0.1258$
 $\alpha = 12.4^\circ$, $M_\infty = 0.899$
 $R_{mac} = 6.0 \times 10^6$

Leading Edge Pressures



x/c_R	starb'd C_p	port C_p
0.10	-0.7030	*****
0.20	-0.9973	-1.0031
0.30	-1.1345	*****
0.40	-1.0090	-1.0490
0.50	-0.8936	*****
0.60	-0.6795	-0.8035
0.70	-0.7196	*****
0.80	-0.7761	-0.7780
0.90	*****	*****
0.95	-0.3812	-0.4162

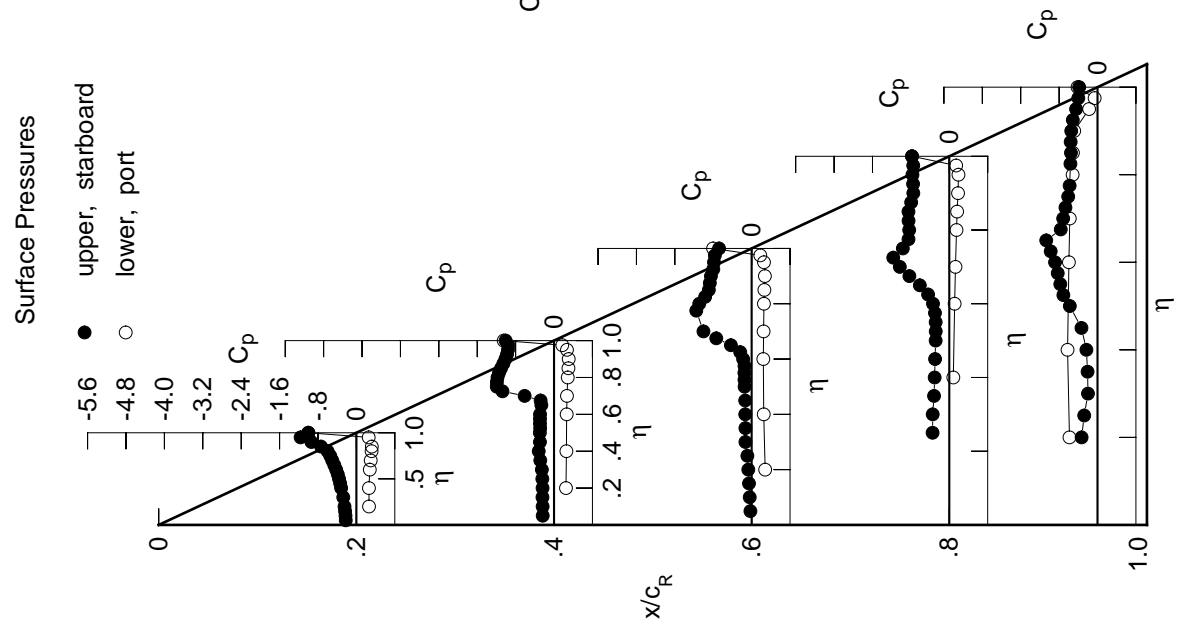

Table F4. Continued.

η	$x/c_R = 0.2$		$x/c_R = 0.4$		$x/c_R = 0.6$		$x/c_R = 0.8$		$x/c_R = 0.95$	
	$C_{p,u}$	$C_{p,u}$	$C_{p,u}$	$C_{p,u}$	$C_{p,u}$	$C_{p,u}$	$C_{p,u}$	$C_{p,u}$	$C_{p,u}$	$C_{p,u}$
0.050	-0.2396	-0.2691	-0.0418	*****	*****	*****	*****	*****	*****	*****
0.100	-0.2440	-0.2676	-0.0551	*****	*****	*****	*****	*****	*****	*****
0.150	-0.2596	-0.2698	-0.0678	*****	*****	*****	*****	*****	*****	*****
0.200	-0.2700	-0.2703	-0.0957	*****	*****	*****	*****	*****	*****	-0.2771
0.250	*****	-0.2966	-0.1271	-0.3758	-0.2052	*****	*****	*****	*****	*****
0.300	-0.3000	-0.3131	-0.1321	-0.3528	-0.1877	*****	*****	*****	*****	*****
0.350	*****	-0.3044	-0.1350	-0.3387	-0.1830	*****	*****	*****	*****	*****
0.400	-0.3377	-0.3035	-0.1470	-0.3221	-0.2188	*****	*****	*****	*****	*****
0.450	-0.3524	-0.3056	-0.1495	-0.3112	-0.3203	*****	*****	*****	*****	*****
0.500	-0.3740	-0.3105	-0.1669	-0.3023	-0.5144	*****	*****	*****	*****	*****
0.525	*****	-0.3099	-0.1762	-0.3070	-0.6386	*****	*****	*****	*****	*****
0.550	-0.3992	-0.3114	-0.2015	-0.3298	-0.7022	*****	*****	*****	*****	*****
0.575	*****	-0.3060	-0.2564	-0.3824	-0.7707	*****	*****	*****	*****	*****
0.600	-0.4334	-0.3129	-0.4222	-0.4884	-0.8425	*****	*****	*****	*****	*****
0.625	*****	*****	-0.6385	-0.6627	-0.9380	*****	*****	*****	*****	*****
0.650	-0.4770	-0.5848	-0.9016	-0.8651	-0.7233	*****	*****	*****	*****	*****
0.675	*****	-0.8963	-1.0838	-1.0523	-0.6830	*****	*****	*****	*****	*****
0.700	-0.4995	-1.1096	-1.1878	-1.1961	-0.6802	*****	*****	*****	*****	*****
0.725	*****	-1.1437	*****	-1.1893	-0.6453	*****	*****	*****	*****	*****
0.750	-0.6621	-1.1966	*****	-0.9579	-0.5973	*****	*****	*****	*****	*****
0.775	*****	-1.2548	-1.0864	-0.9157	-0.5743	*****	*****	*****	*****	*****
0.800	-0.9096	-1.2276	-1.0036	-0.9070	*****	*****	*****	*****	*****	*****
0.825	*****	-1.1704	-0.9453	-0.9045	-0.5519	*****	*****	*****	*****	*****
0.850	-1.0746	-1.1143	-0.9201	-0.8991	-0.5436	*****	*****	*****	*****	*****
0.875	*****	-1.0397	-0.9113	-0.8570	-0.5700	*****	*****	*****	*****	*****
0.900	-1.1065	-0.9928	-0.8835	-0.7687	-0.5743	*****	*****	*****	*****	*****
0.925	*****	-0.9554	-0.8409	-0.7431	-0.5435	*****	*****	*****	*****	*****
0.950	-1.0934	-0.9309	-0.8236	-0.7676	-0.4690	*****	*****	*****	*****	*****
0.975	*****	-0.9190	-0.8024	-0.7550	-0.4074	*****	*****	*****	*****	*****
1.000	-1.0543	-0.9518	-0.7164	-0.7733	-0.3760	*****	*****	*****	*****	*****
-0.200	$C_{p,l}$	$C_{p,l}$	$C_{p,l}$	$C_{p,l}$	$C_{p,l}$	$C_{p,l}$	$C_{p,l}$	$C_{p,l}$	$C_{p,l}$	$C_{p,l}$
-0.400	0.2925	0.2754	0.2987	*****	-0.5746	*****	*****	*****	*****	*****
-0.600	0.2930	0.2827	0.2718	0.0992	-0.6135	*****	*****	*****	*****	*****
-0.700	0.3097	0.2895	0.2602	0.1288	-0.5864	*****	*****	*****	*****	*****
-0.800	0.3266	0.2943	0.2694	0.1443	-0.5671	*****	*****	*****	*****	*****
-0.850	0.3424	0.3108	0.2750	0.1670	-0.5051	*****	*****	*****	*****	*****
-0.900	0.3434	0.3221	0.2828	0.1789	-0.4991	*****	*****	*****	*****	*****
-0.950	*****	0.3223	0.2886	0.1965	-0.4689	*****	*****	*****	*****	*****
-0.975	*****	0.2579	0.2740	0.2570	-0.1659	*****	*****	*****	*****	*****
-1.000	*****	0.1623	0.1662	0.1352	-0.0595	*****	*****	*****	*****	*****
		-1.0455	-0.9876	-0.8405	-0.8049	-0.3928	*****	*****	*****	*****

Medium Radius L.E.
 Run No. = 9, Point No. = 185
 $C_N = 0.667$, $C_m = -0.1355$
 $\alpha = 13.4^\circ$, $M_\infty = 0.898$
 $R_{mac} = 6.0 \times 10^6$

Leading Edge Pressures

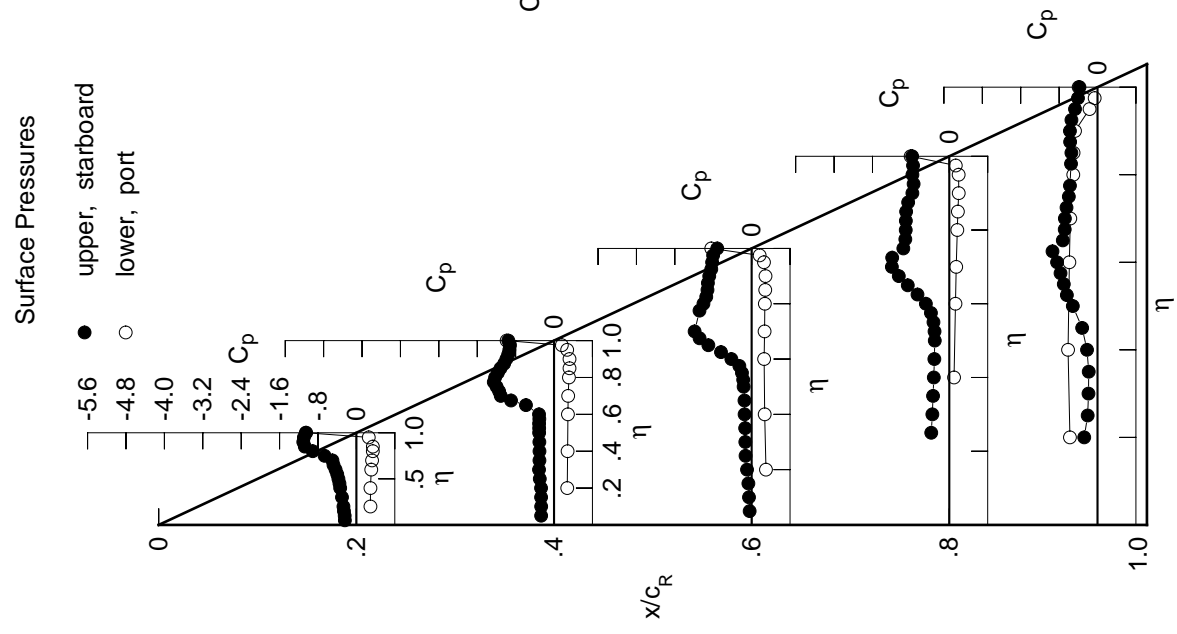
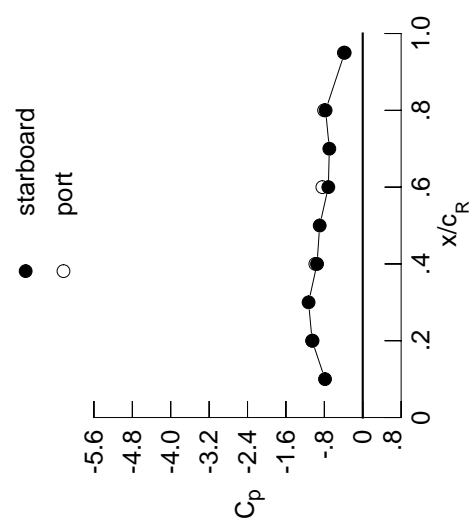
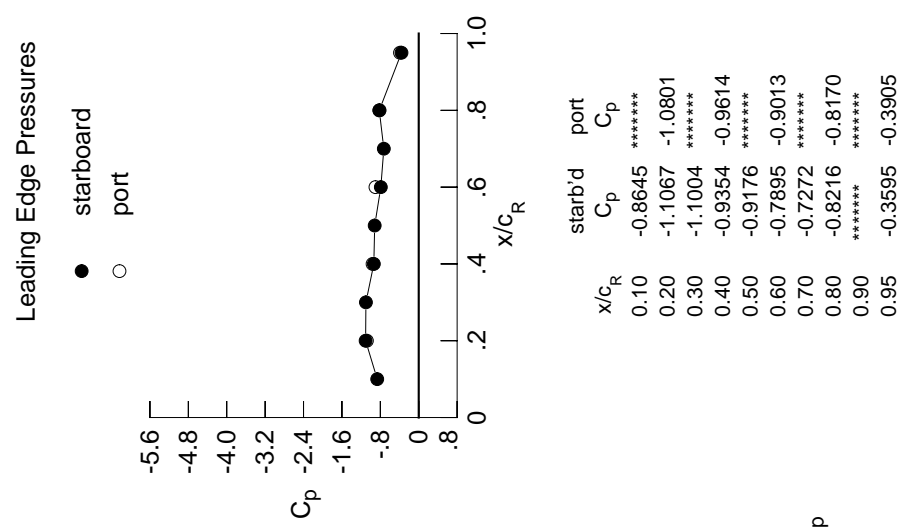

Table F4. Continued.

η	$x/c_R = .2$		$x/c_R = .4$		$x/c_R = .6$		$x/c_R = .8$		$x/c_R = .95$	
	$C_{p,u}$	$C_{p,u}$	$C_{p,u}$	$C_{p,u}$	$C_{p,u}$	$C_{p,u}$	$C_{p,u}$	$C_{p,u}$	$C_{p,u}$	$C_{p,u}$
0.050	-0.2577	-0.3036	-0.0719	*****	*****	*****	*****	*****	*****	*****
0.100	-0.2561	-0.3009	-0.0861	*****	*****	*****	*****	*****	*****	*****
0.150	-0.2783	-0.3015	-0.1077	*****	*****	*****	*****	*****	*****	*****
0.200	-0.2959	-0.3091	-0.1469	*****	*****	*****	*****	*****	*****	-0.2702
0.250	*****	-0.3358	-0.1610	-0.3932	-0.3932	-0.2222	*****	*****	*****	*****
0.300	-0.3198	-0.3269	-0.1724	-0.3705	-0.3705	-0.1993	*****	*****	*****	*****
0.350	*****	-0.3237	-0.1874	-0.3521	-0.3521	-0.2028	*****	*****	*****	*****
0.400	-0.3537	-0.3235	-0.2116	-0.3396	-0.3396	-0.2397	*****	*****	*****	*****
0.450	-0.3670	-0.3298	-0.2277	-0.3366	-0.3366	-0.3284	*****	*****	*****	*****
0.500	-0.3890	-0.3298	-0.2691	-0.3524	-0.3524	-0.4520	*****	*****	*****	*****
0.525	*****	-0.3258	-0.3031	-0.3842	-0.3842	-0.5296	*****	*****	*****	*****
0.550	-0.4084	-0.3266	-0.3732	-0.4506	-0.4506	-0.5902	*****	*****	*****	*****
0.575	*****	-0.3406	-0.4937	-0.5589	-0.5589	-0.6971	*****	*****	*****	*****
0.600	-0.4155	-0.3977	-0.7110	-0.7065	-0.7065	-0.8028	*****	*****	*****	*****
0.625	*****	*****	-0.9161	-0.8816	-0.8816	-0.6848	*****	*****	*****	*****
0.650	-0.4457	-0.9055	-1.1085	-1.0442	-1.0442	-0.6534	*****	*****	*****	*****
0.675	*****	-1.1748	-1.2391	-1.1788	-1.1788	-0.6431	*****	*****	*****	*****
0.700	-0.7370	-1.3233	-1.3147	-1.1389	-1.1389	-0.6269	*****	*****	*****	*****
0.725	*****	-1.3260	*****	-0.9353	-0.5994	*****	*****	*****	*****	*****
0.750	-0.9829	-1.2516	*****	-0.9174	-0.5763	*****	*****	*****	*****	*****
0.775	*****	-1.2902	-1.0084	-0.9041	-0.5510	*****	*****	*****	*****	*****
0.800	-1.0980	-1.2869	-0.9812	-0.9072	*****	*****	*****	*****	*****	*****
0.825	*****	-1.1805	-0.9786	-0.9317	-0.5279	*****	*****	*****	*****	*****
0.850	-1.1493	-1.0883	-0.9890	-0.9344	-0.5315	*****	*****	*****	*****	*****
0.875	*****	-1.0319	-0.9526	-0.8544	-0.5457	*****	*****	*****	*****	*****
0.900	-1.1272	-1.0012	-0.9096	-0.7915	-0.5286	*****	*****	*****	*****	*****
0.925	*****	-0.9584	-0.9057	-0.7956	-0.4808	*****	*****	*****	*****	*****
0.950	-1.1061	-0.9303	-0.9071	-0.8139	-0.4201	*****	*****	*****	*****	*****
0.975	*****	-0.9154	-0.8894	-0.8046	-0.3814	*****	*****	*****	*****	*****
1.000	-1.1067	-0.9354	-0.7895	-0.8216	-0.3595	*****	*****	*****	*****	*****
-0.200	$C_{p,l}$	$C_{p,l}$	$C_{p,l}$	$C_{p,l}$	$C_{p,l}$	$C_{p,l}$	$C_{p,l}$	$C_{p,l}$	$C_{p,l}$	$C_{p,l}$
-0.400	0.3222	0.2971	0.3164	*****	*****	-0.5643	*****	*****	*****	*****
-0.600	0.3225	0.3053	0.2886	0.1155	-0.6018	*****	*****	*****	*****	*****
-0.700	0.3358	0.3141	0.2784	0.1435	-0.5789	*****	*****	*****	*****	*****
-0.800	0.3524	0.3190	0.2860	0.1584	-0.5559	*****	*****	*****	*****	*****
-0.850	0.3636	0.3312	0.2915	0.1822	-0.4958	*****	*****	*****	*****	*****
-0.880	0.3613	0.3383	0.2987	0.1932	-0.4875	*****	*****	*****	*****	*****
-0.900	*****	0.3327	0.2998	0.2074	-0.4543	*****	*****	*****	*****	*****
-0.950	0.2554	0.2736	0.2555	0.1975	-0.1605	*****	*****	*****	*****	*****
-0.975	*****	0.1479	0.1495	0.1250	-0.0648	*****	*****	*****	*****	*****
-1.000	-1.0801	-0.9614	-0.9013	-0.8170	-0.3905	*****	*****	*****	*****	*****

Medium Radius L.E.
 Run No. = 9, Point No. = 186
 $C_N = 0.721$, $C_m = -0.1443$
 $\alpha = 14.5^\circ$, $M_\infty = 0.899$
 $R_{mac} = 6.0 \times 10^6$



x/c_R	starb'd C_p	port C_p
0.10	-0.8645	*****
0.20	-1.1067	-1.0801
0.30	-1.1004	*****
0.40	-0.9354	-0.9614
0.50	-0.9176	*****
0.60	-0.7895	-0.9013
0.70	-0.7272	*****
0.80	-0.8216	-0.8170
0.90	*****	*****
0.95	-0.3595	-0.3905

Table F4. Continued.

η	$x/c_R = .2$		$x/c_R = .4$		$x/c_R = .6$		$x/c_R = .8$		$x/c_R = .95$	
	$C_{p,u}$	$C_{p,u}$	$C_{p,u}$	$C_{p,u}$	$C_{p,u}$	$C_{p,u}$	$C_{p,u}$	$C_{p,u}$	$C_{p,u}$	$C_{p,u}$
0.050	-0.2962	-0.3526	-0.2773	*****	*****	*****	*****	*****	*****	*****
0.100	-0.2925	-0.3463	-0.2978	*****	*****	*****	*****	*****	*****	*****
0.150	-0.3202	-0.3565	-0.3171	*****	*****	*****	*****	*****	*****	*****
0.200	-0.3569	-0.3702	-0.3237	*****	*****	*****	*****	*****	*****	-0.3494
0.250	*****	-0.3671	-0.3393	-0.4212	-0.2871	*****	*****	*****	*****	-0.2871
0.300	-0.3525	-0.3684	-0.3629	-0.4016	-0.2417	*****	*****	*****	*****	-0.2417
0.350	*****	-0.3688	-0.3813	-0.3919	-0.2468	*****	*****	*****	*****	-0.2468
0.400	-0.3778	-0.3708	-0.3975	-0.3938	-0.2874	*****	*****	*****	*****	-0.2874
0.450	-0.3979	-0.3765	-0.4256	-0.4248	-0.3741	*****	*****	*****	*****	-0.3741
0.500	-0.4040	-0.3992	-0.5267	-0.5201	-0.5237	*****	*****	*****	*****	-0.5237
0.525	*****	-0.4447	-0.6264	-0.6026	-0.6287	*****	*****	*****	*****	-0.6287
0.550	-0.3766	-0.5377	-0.7656	-0.7202	-0.7462	*****	*****	*****	*****	-0.7462
0.575	*****	-0.7075	-0.9266	-0.8494	-0.7680	*****	*****	*****	*****	-0.7680
0.600	-0.3719	-0.9220	-1.1004	-0.9897	-0.6987	*****	*****	*****	*****	-0.6987
0.625	*****	*****	-1.2347	-1.1191	-0.7040	*****	*****	*****	*****	-0.7040
0.650	-1.1129	-1.3174	-1.3431	-1.2349	-0.7055	*****	*****	*****	*****	-0.7055
0.675	*****	-1.4190	-1.2749	-1.0932	-0.6936	*****	*****	*****	*****	-0.6936
0.700	-1.2576	-1.4759	-1.1353	-0.9859	-0.6912	*****	*****	*****	*****	-0.6912
0.725	*****	-1.4273	*****	-0.9779	-0.6771	*****	*****	*****	*****	-0.6771
0.750	-1.2463	-1.3156	*****	-0.9737	-0.6279	*****	*****	*****	*****	-0.6279
0.775	*****	-1.2828	-1.1274	-0.9748	-0.5559	*****	*****	*****	*****	-0.5559
0.800	-1.2429	-1.2138	-1.1566	-0.9922	*****	*****	*****	*****	*****	*****
0.825	*****	-1.1249	-1.1894	-1.0006	-0.5019	*****	*****	*****	*****	-0.5019
0.850	-1.2086	-1.0883	-1.1234	-0.9647	-0.4942	*****	*****	*****	*****	-0.4942
0.875	*****	-1.0686	-1.0231	-0.8947	-0.5112	*****	*****	*****	*****	-0.5112
0.900	-1.1549	-1.0393	-0.9979	-0.8412	-0.5161	*****	*****	*****	*****	-0.5161
0.925	*****	-0.9871	-1.0051	-0.8228	-0.4936	*****	*****	*****	*****	-0.4936
0.950	-1.1371	-0.9731	-1.0132	-0.8329	-0.4383	*****	*****	*****	*****	-0.4383
0.975	*****	-0.9623	-1.0019	-0.8306	-0.4044	*****	*****	*****	*****	-0.4044
1.000	-1.1890	-0.9746	-0.8853	-0.8364	-0.3861	*****	*****	*****	*****	-0.3861
-0.200	$C_{p,l}$	$C_{p,l}$	$C_{p,l}$	$C_{p,l}$	$C_{p,l}$	$C_{p,l}$	$C_{p,l}$	$C_{p,l}$	$C_{p,l}$	$C_{p,l}$
-0.400	0.3779	0.3466	0.3531	*****	-0.5420	*****	*****	*****	*****	-0.5420
-0.600	0.3813	0.3528	0.3255	0.1466	-0.5809	*****	*****	*****	*****	-0.5809
-0.700	0.3958	0.3592	0.3164	0.1758	-0.5570	*****	*****	*****	*****	-0.5570
-0.800	0.4086	0.3630	0.3220	0.1897	-0.5348	*****	*****	*****	*****	-0.5348
-0.850	0.4087	0.3723	0.3235	0.2126	-0.4716	*****	*****	*****	*****	-0.4716
-0.900	0.3985	0.3756	0.3271	0.2185	-0.4628	*****	*****	*****	*****	-0.4628
-0.950	*****	0.3560	0.3178	0.2290	-0.4240	*****	*****	*****	*****	-0.4240
-0.975	0.2525	0.2733	0.2503	0.1970	-0.1498	*****	*****	*****	*****	-0.1498
-1.000	*****	0.1213	0.1187	0.0991	-0.0750	*****	*****	*****	*****	-0.0750
-1.000	-1.1438	-0.9975	-1.0260	-0.8498	-0.3976	*****	*****	*****	*****	-0.3976

Medium Radius L.E.

Run No. = 9, Point No. = 187

$C_N = 0.832$, $C_m = -0.1639$

$\alpha = 16.5^\circ$, $M_\infty = 0.898$

$R_{mac} = 6.0 \times 10^6$

Leading Edge Pressures

● starboard
○ port

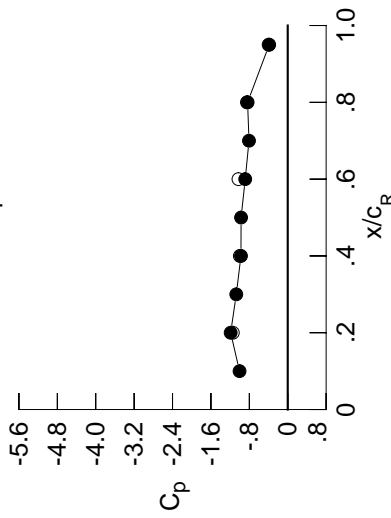

x/c_R	starb'd C_p	port C_p
0.10	-1.0043	*****
0.20	-1.1890	-1.1438
0.30	-1.0719	*****
0.40	-0.9746	-0.9975
0.50	-0.9717	*****
0.60	-0.8853	-1.0260
0.70	-0.8069	*****
0.80	-0.8364	-0.8498
0.90	*****	*****
0.95	-0.3861	-0.3976

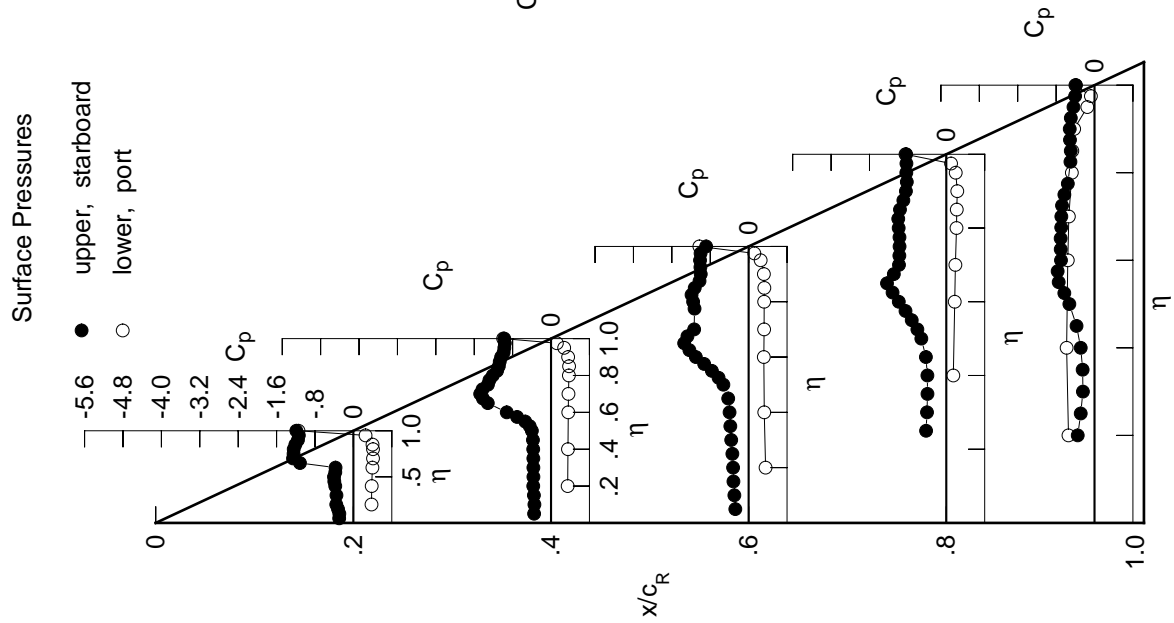

Table F4. Continued.

η	$x/c_R = .2$		$x/c_R = .4$		$x/c_R = .6$		$x/c_R = .8$		$x/c_R = .95$	
	$C_{p,u}$	$C_{p,u}$	$C_{p,u}$	$C_{p,u}$	$C_{p,u}$	$C_{p,u}$	$C_{p,u}$	$C_{p,u}$	$C_{p,u}$	$C_{p,u}$
0.050	-0.3471	-0.4211	-0.4392	*****	*****	*****	*****	*****	*****	*****
0.100	-0.3447	-0.4139	-0.4468	*****	*****	*****	*****	*****	*****	*****
0.150	-0.3873	-0.4390	-0.4539	*****	*****	*****	*****	*****	*****	*****
0.200	-0.3957	-0.4302	-0.4532	*****	*****	*****	*****	*****	*****	*****
0.250	*****	-0.4349	-0.4597	-0.4295	-0.4295	-0.4295	-0.4295	-0.4295	-0.4295	-0.4295
0.300	-0.3872	-0.4390	-0.4713	-0.4245	-0.4245	-0.4245	-0.4245	-0.4245	-0.4245	-0.4245
0.350	*****	-0.4447	-0.4862	-0.4403	-0.4403	-0.4403	-0.4403	-0.4403	-0.4403	-0.4403
0.400	-0.4171	-0.4589	-0.5240	-0.4787	-0.4787	-0.4787	-0.4787	-0.4787	-0.4787	-0.4787
0.450	-0.4269	-0.5012	-0.6050	-0.5817	-0.5817	-0.5817	-0.5817	-0.5817	-0.5817	-0.5817
0.500	-0.4117	-0.6336	-0.7952	-0.7620	-0.7620	-0.7620	-0.7620	-0.7620	-0.7620	-0.7620
0.525	*****	-0.7588	-0.9198	-0.8807	-0.8807	-0.8807	-0.8807	-0.8807	-0.8807	-0.8807
0.550	-0.4971	-0.9228	-1.0588	-1.0038	-1.0038	-1.0038	-1.0038	-1.0038	-1.0038	-1.0038
0.575	*****	-1.0941	-1.1810	-1.1220	-1.1220	-1.1220	-1.1220	-1.1220	-1.1220	-1.1220
0.600	-1.1647	-1.2467	-1.3003	-1.2224	-1.2224	-1.2224	-1.2224	-1.2224	-1.2224	-1.2224
0.625	*****	*****	-1.3750	-1.3109	-1.3109	-1.3109	-1.3109	-1.3109	-1.3109	-1.3109
0.650	-1.4350	-1.4681	-1.1832	-1.2385	-1.2385	-1.2385	-1.2385	-1.2385	-1.2385	-1.2385
0.675	*****	-1.4721	-1.1527	-1.0886	-1.0886	-1.0886	-1.0886	-1.0886	-1.0886	-1.0886
0.700	-1.4002	-1.3567	-1.1538	-1.0748	-1.0748	-1.0748	-1.0748	-1.0748	-1.0748	-1.0748
0.725	*****	-1.3225	*****	-1.0662	-1.0662	-1.0662	-1.0662	-1.0662	-1.0662	-1.0662
0.750	-1.3685	-1.3216	*****	-1.0585	-1.0585	-1.0585	-1.0585	-1.0585	-1.0585	-1.0585
0.775	*****	-1.3255	-1.2103	-1.0424	-1.0424	-1.0424	-1.0424	-1.0424	-1.0424	-1.0424
0.800	-1.3133	-1.3152	-1.2368	-1.0396	-1.0396	-1.0396	-1.0396	-1.0396	-1.0396	-1.0396
0.825	*****	-1.2607	-1.1973	-1.0430	-1.0430	-1.0430	-1.0430	-1.0430	-1.0430	-1.0430
0.850	-1.2285	-1.1777	-1.1236	-1.0216	-1.0216	-1.0216	-1.0216	-1.0216	-1.0216	-1.0216
0.875	*****	-1.1014	-1.0934	-0.9601	-0.9601	-0.9601	-0.9601	-0.9601	-0.9601	-0.9601
0.900	-1.1686	-1.0650	-1.0902	-0.9029	-0.9029	-0.9029	-0.9029	-0.9029	-0.9029	-0.9029
0.925	*****	-1.0425	-1.0975	-0.8823	-0.8823	-0.8823	-0.8823	-0.8823	-0.8823	-0.8823
0.950	-1.1433	-1.0349	-1.0967	-0.8872	-0.8872	-0.8872	-0.8872	-0.8872	-0.8872	-0.8872
0.975	*****	-1.0268	-1.0813	-0.8837	-0.8837	-0.8837	-0.8837	-0.8837	-0.8837	-0.8837
1.000	-1.2195	-1.0393	-0.9494	-0.8805	-0.8805	-0.8805	-0.8805	-0.8805	-0.8805	-0.8805
-0.200	$C_{p,l}$	$C_{p,l}$	$C_{p,l}$	$C_{p,l}$	$C_{p,l}$	$C_{p,l}$	$C_{p,l}$	$C_{p,l}$	$C_{p,l}$	$C_{p,l}$
-0.400	0.4371	0.3942	0.3899	*****	*****	*****	*****	*****	*****	*****
-0.600	0.4407	0.3989	0.3660	0.1807	0.1807	0.1807	0.1807	0.1807	0.1807	0.1807
-0.700	0.4537	0.4084	0.3547	0.2078	0.2078	0.2078	0.2078	0.2078	0.2078	0.2078
-0.800	0.4616	0.4098	0.3587	0.2194	0.2194	0.2194	0.2194	0.2194	0.2194	0.2194
-0.850	0.4516	0.4130	0.3578	0.2372	0.2372	0.2372	0.2372	0.2372	0.2372	0.2372
-0.900	0.4308	0.4081	0.3562	0.2451	0.2451	0.2451	0.2451	0.2451	0.2451	0.2451
-0.950	*****	0.3763	0.3372	0.2468	0.2468	0.2468	0.2468	0.2468	0.2468	0.2468
-0.975	0.2491	0.2681	0.2439	0.1946	0.1946	0.1946	0.1946	0.1946	0.1946	0.1946
-1.000	*****	0.0908	0.0882	0.0734	0.0734	0.0734	0.0734	0.0734	0.0734	0.0734
-1.000	-1.1896	-1.0536	-1.1072	-0.8884	-0.8884	-0.8884	-0.8884	-0.8884	-0.8884	-0.8884

Medium Radius L.E.
 Run No. = 9, Point No. = 188
 $C_N = 0.950$, $C_m = -0.1891$
 $\alpha = 18.6^\circ$, $M_\infty = 0.897$
 $R_{mac} = 6.0 \times 10^6$

Leading Edge Pressures

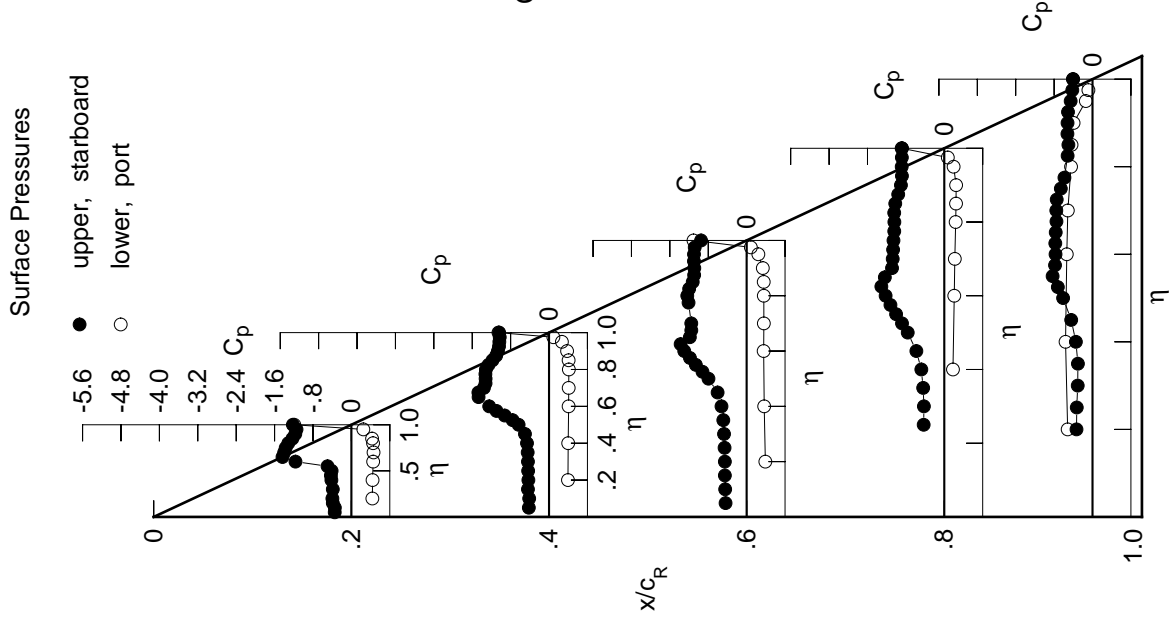
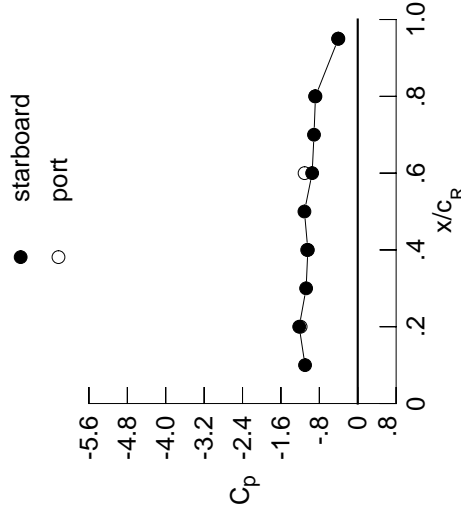
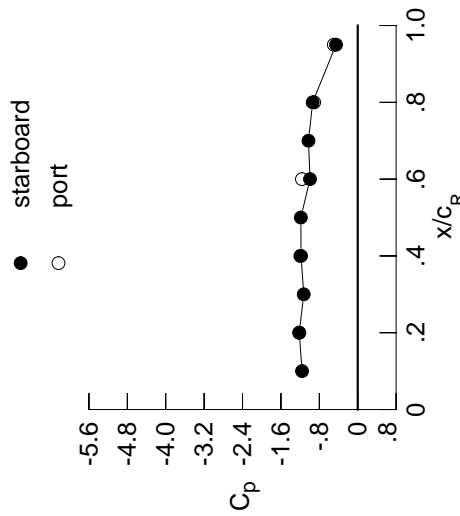

Table F4. Continued.

η	$x/c_R = .2$		$x/c_R = .4$		$x/c_R = .6$		$x/c_R = .8$		$x/c_R = .95$	
	$C_{p,u}$	$C_{p,u}$	$C_{p,u}$	$C_{p,u}$	$C_{p,u}$	$C_{p,u}$	$C_{p,u}$	$C_{p,u}$	$C_{p,u}$	$C_{p,u}$
0.050	-0.4090	-0.4962	-0.5063	*****	*****	*****	*****	*****	*****	*****
0.100	-0.4196	-0.4933	-0.5101	*****	*****	*****	*****	*****	*****	*****
0.150	-0.4454	-0.5142	-0.5087	*****	*****	*****	*****	*****	*****	*****
0.200	-0.4388	-0.5030	-0.5245	*****	*****	*****	*****	*****	*****	-0.2907
0.250	*****	-0.5140	-0.5304	-0.5197	-0.3500	*****	*****	*****	*****	*****
0.300	-0.4435	-0.5234	-0.5514	-0.5321	-0.4192	*****	*****	*****	*****	*****
0.350	*****	-0.5429	-0.5924	-0.5702	-0.4637	*****	*****	*****	*****	*****
0.400	-0.4748	-0.5933	-0.6800	-0.6450	-0.5451	*****	*****	*****	*****	*****
0.450	-0.4875	-0.7078	-0.8358	-0.7858	-0.6774	*****	*****	*****	*****	*****
0.500	-0.6033	-0.9190	-1.0519	-0.9843	-0.8741	*****	*****	*****	*****	*****
0.525	*****	-1.0560	-1.1632	-1.0898	-0.9683	*****	*****	*****	*****	*****
0.550	-1.0564	-1.1859	-1.2624	-1.1944	-0.9027	*****	*****	*****	*****	*****
0.575	*****	-1.3008	-1.3470	-1.2821	-0.8377	*****	*****	*****	*****	*****
0.600	-1.4494	-1.3933	-1.4218	-1.3573	-0.8514	*****	*****	*****	*****	*****
0.625	*****	*****	-1.3699	-1.3934	-0.8620	*****	*****	*****	*****	*****
0.650	-1.5240	-1.3189	-1.2509	-1.1860	-0.8585	*****	*****	*****	*****	*****
0.675	*****	-1.2771	-1.2393	-1.1676	-0.8455	*****	*****	*****	*****	*****
0.700	-1.5153	-1.2695	-1.2350	-1.1686	-0.8456	*****	*****	*****	*****	*****
0.725	*****	-1.2738	*****	-1.1642	-0.8279	*****	*****	*****	*****	*****
0.750	-1.4197	-1.2949	*****	-1.1663	-0.7532	*****	*****	*****	*****	*****
0.775	*****	-1.3391	-1.2575	-1.1635	-0.6517	*****	*****	*****	*****	*****
0.800	-1.3422	-1.3477	-1.2721	-1.1783	*****	*****	*****	*****	*****	*****
0.825	*****	-1.2560	-1.2443	-1.1811	-0.5493	*****	*****	*****	*****	*****
0.850	-1.2430	-1.1723	-1.1903	-1.1544	-0.5298	*****	*****	*****	*****	*****
0.875	*****	-1.1517	-1.1551	-1.0653	-0.5653	*****	*****	*****	*****	*****
0.900	-1.1878	-1.1586	-1.1458	-0.9847	-0.5682	*****	*****	*****	*****	*****
0.925	*****	-1.1625	-1.1466	-0.9455	-0.5748	*****	*****	*****	*****	*****
0.950	-1.1548	-1.1575	-1.1464	-0.9518	-0.5078	*****	*****	*****	*****	*****
0.975	*****	-1.1542	-1.1381	-0.9442	-0.4726	*****	*****	*****	*****	*****
1.000	-1.2176	-1.1812	-0.9942	-0.9392	-0.4523	*****	*****	*****	*****	*****
η	$C_{p,l}$	$C_{p,l}$	$C_{p,l}$	$C_{p,l}$	$C_{p,l}$	$C_{p,l}$	$C_{p,l}$	$C_{p,l}$	$C_{p,l}$	$C_{p,l}$
-0.200	0.4956	0.4432	0.4281	*****	-0.4936	*****	*****	*****	*****	*****
-0.400	0.4987	0.4480	0.4016	0.2100	-0.5378	*****	*****	*****	*****	*****
-0.600	0.5081	0.4516	0.3902	0.2395	-0.5125	*****	*****	*****	*****	*****
-0.700	0.5104	0.4525	0.3938	0.2469	-0.4895	*****	*****	*****	*****	*****
-0.800	0.4901	0.4493	0.3903	0.2648	-0.4182	*****	*****	*****	*****	*****
-0.850	0.4605	0.4368	0.3838	0.2693	-0.4070	*****	*****	*****	*****	*****
-0.900	*****	0.3919	0.3529	0.2632	-0.3658	*****	*****	*****	*****	*****
-0.950	0.2422	0.2598	0.2371	0.1897	-0.1306	*****	*****	*****	*****	*****
-0.975	*****	0.0583	0.0610	0.0456	-0.1004	*****	*****	*****	*****	*****
-1.000	-1.2190	-1.1958	-1.1624	-0.9071	-0.4974	*****	*****	*****	*****	*****

Medium Radius L.E.
 Run No. = 9, Point No. = 189
 $C_N = 1.063$, $C_m = -0.2115$
 $\alpha = 20.6^\circ$, $M_\infty = 0.897$
 $R_{mac} = 6.0 \times 10^6$

Leading Edge Pressures



x/c_R	starb'd C_p	port C_p
0.10	-1.1600	*****
0.20	-1.2176	-1.2190
0.30	-1.1249	*****
0.40	-1.1812	-1.1958
0.50	-1.1849	*****
0.60	-0.9942	-1.1624
0.70	-1.0259	*****
0.80	-0.9392	-0.9071
0.90	*****	*****
0.95	-0.4523	-0.4974

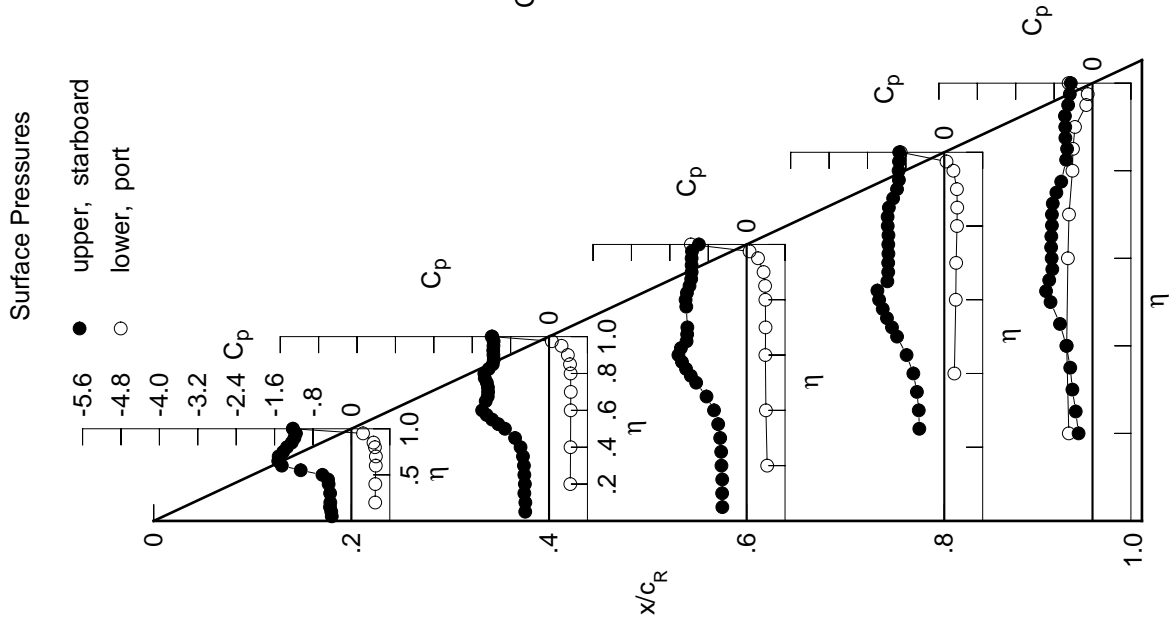
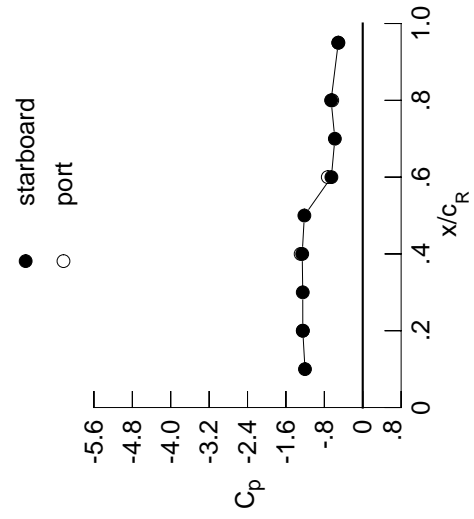

Table F4. Continued.

η	$x/c_R = .2$		$x/c_R = .4$		$x/c_R = .6$		$x/c_R = .8$		$x/c_R = .95$	
	$C_{p,u}$	$C_{p,u}$	$C_{p,u}$	$C_{p,u}$	$C_{p,u}$	$C_{p,u}$	$C_{p,u}$	$C_{p,u}$	$C_{p,u}$	$C_{p,u}$
0.050	-0.4701	-0.5562	-0.0741	*****	*****	*****	*****	*****	*****	*****
0.100	-0.4820	-0.5580	-0.0876	*****	*****	*****	*****	*****	*****	*****
0.150	-0.5077	-0.5647	-0.1102	*****	*****	*****	*****	*****	*****	*****
0.200	-0.5001	-0.5806	-0.1385	*****	*****	*****	*****	*****	*****	-0.5604
0.250	*****	-0.5939	-0.1808	-0.6316	-0.5986	*****	*****	*****	*****	*****
0.300	-0.5079	-0.6186	-0.2495	-0.6774	-0.6515	*****	*****	*****	*****	*****
0.350	*****	-0.6660	-0.3594	-0.7555	-0.7102	*****	*****	*****	*****	*****
0.400	-0.5611	-0.7595	-0.5304	-0.8368	-0.7885	*****	*****	*****	*****	*****
0.450	-0.6663	-0.9206	-0.7485	-0.9245	-0.8491	*****	*****	*****	*****	*****
0.500	-0.9623	-1.1226	-1.0224	-0.9707	-0.8367	*****	*****	*****	*****	*****
0.525	*****	-1.2292	-1.1445	-0.9659	-0.8190	*****	*****	*****	*****	*****
0.550	-1.3288	-1.3202	-1.2285	-0.9377	-0.7772	*****	*****	*****	*****	*****
0.575	*****	-1.4023	-1.2429	-0.9135	-0.7612	*****	*****	*****	*****	*****
0.600	-1.5415	-1.4166	-1.1703	-0.8922	-0.7456	*****	*****	*****	*****	*****
0.625	*****	*****	-1.1119	-0.8818	-0.7474	*****	*****	*****	*****	*****
0.650	-1.5351	-1.2727	-1.0709	-0.8975	-0.7490	*****	*****	*****	*****	*****
0.675	*****	-1.2739	-1.0470	-0.8900	-0.7404	*****	*****	*****	*****	*****
0.700	-1.5381	-1.2787	-1.0304	-0.8658	-0.7426	*****	*****	*****	*****	*****
0.725	*****	-1.2848	*****	-0.8579	-0.7382	*****	*****	*****	*****	*****
0.750	-1.5408	-1.3048	*****	-0.8367	-0.7308	*****	*****	*****	*****	*****
0.775	*****	-1.3237	-0.9778	-0.8104	-0.7114	*****	*****	*****	*****	*****
0.800	-1.3037	-1.2931	-0.9655	-0.7891	*****	*****	*****	*****	*****	*****
0.825	*****	-1.2493	-0.9590	-0.7771	-0.6793	*****	*****	*****	*****	*****
0.850	-1.2390	-1.2302	-0.9041	-0.7600	-0.6639	*****	*****	*****	*****	*****
0.875	*****	-1.2378	-0.8476	-0.7493	-0.6468	*****	*****	*****	*****	*****
0.900	-1.2077	-1.2468	-0.8106	-0.7344	-0.6280	*****	*****	*****	*****	*****
0.925	*****	-1.2426	-0.7882	-0.7080	-0.6209	*****	*****	*****	*****	*****
0.950	-1.1899	-1.2335	-0.7733	-0.6896	-0.5753	*****	*****	*****	*****	*****
0.975	*****	-1.2244	-0.7591	-0.6675	-0.5360	*****	*****	*****	*****	*****
1.000	-1.2488	-1.2610	-0.6530	-0.6588	-0.5096	*****	*****	*****	*****	*****
-0.200	$C_{p,l}$	$C_{p,l}$	$C_{p,l}$	$C_{p,l}$	$C_{p,l}$	$C_{p,l}$	$C_{p,l}$	$C_{p,l}$	$C_{p,l}$	$C_{p,l}$
-0.400	0.5538	0.4929	0.4687	*****	*****	*****	*****	*****	*****	-0.4800
-0.600	0.5557	0.4992	0.4439	0.2472	0.5252	*****	*****	*****	*****	*****
-0.700	0.5615	0.4998	0.4324	0.2695	-0.5000	*****	*****	*****	*****	*****
-0.800	0.5572	0.4972	0.4339	0.2807	-0.4737	*****	*****	*****	*****	*****
-0.850	0.5259	0.4872	0.4293	0.2939	-0.4098	*****	*****	*****	*****	*****
-0.900	0.4872	0.4667	0.4183	0.2978	-0.4024	*****	*****	*****	*****	*****
-0.950	*****	0.4089	0.3810	0.2878	-0.3626	*****	*****	*****	*****	*****
-0.975	0.2351	0.2546	0.2503	0.2130	-0.1406	*****	*****	*****	*****	*****
-1.000	*****	0.0331	0.0615	0.0708	-0.1219	*****	*****	*****	*****	*****
	-1.2487	-1.2935	-0.7284	-0.6352	-0.5082	*****	*****	*****	*****	*****

Medium Radius L.E.
 Run No. = 9, Point No. = 190
 $C_N = 1.038$, $C_m = -0.1908$
 $\alpha = 22.6^\circ$, $M_\infty = 0.898$
 $R_{mac} = 6.0 \times 10^6$

Leading Edge Pressures



x/c_R	starb'd C_p	port C_p
0.10	-1.2028	*****
0.20	-1.2488	-1.2487
0.30	-1.2494	*****
0.40	-1.2610	-1.2935
0.50	-1.2158	*****
0.60	-0.6530	-0.7284
0.70	-0.5807	*****
0.80	-0.6588	-0.6352
0.90	*****	*****
0.95	-0.5096	-0.5082

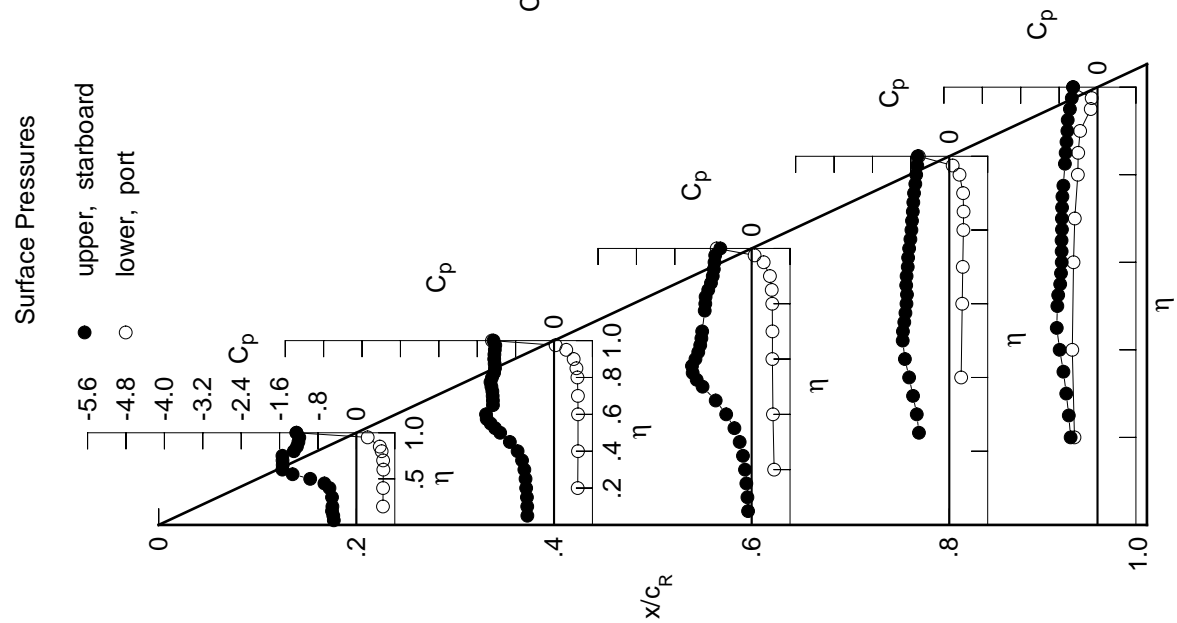

Table F4. Continued.

η	x/c_R .2	x/c_R .4	x/c_R .6	x/c_R .8	x/c_R .95	x/c_R .95
	$C_{p,u}$	$C_{p,u}$	$C_{p,u}$	$C_{p,u}$	$C_{p,u}$	$C_{p,u}$
0.050	-0.5431	-0.6168	-0.0469	*****	*****	*****
0.100	-0.5455	-0.6202	-0.0641	*****	*****	*****
0.150	-0.5643	-0.6313	-0.0805	*****	*****	*****
0.200	-0.5805	-0.6410	-0.1109	*****	*****	-0.6196
0.250	*****	-0.6733	-0.1576	-0.8259	-0.6688	
0.300	-0.6140	-0.7221	-0.2432	-0.8601	-0.7318	
0.350	*****	-0.8012	-0.3719	-0.9115	-0.7969	
0.400	-0.7593	-0.9332	-0.5762	-0.9406	-0.8683	
0.450	-0.9689	-1.1044	-0.8078	-0.9397	-0.8783	
0.500	-1.2517	-1.2783	-1.0565	-0.8941	-0.8214	
0.525	*****	-1.3533	-1.1262	-0.8765	-0.8056	
0.550	-1.4635	-1.4217	-1.1080	-0.8565	-0.7766	
0.575	*****	-1.4747	-1.1022	-0.8674	-0.7783	
0.600	-1.5495	-1.4459	-1.0914	-0.8762	-0.7682	
0.625	*****	*****	-1.0631	-0.8786	-0.7714	
0.650	-1.5123	-1.3407	-1.0295	-0.8766	-0.7724	
0.675	*****	-1.3413	-1.0129	-0.8752	-0.7638	
0.700	-1.5152	-1.3381	-1.0003	-0.8721	-0.7626	
0.725	*****	-1.3396	*****	-0.8726	-0.7599	
0.750	-1.4917	-1.3513	*****	-0.8565	-0.7536	
0.775	*****	-1.3761	-0.9476	-0.8379	-0.7358	
0.800	-1.3146	-1.3587	-0.9243	-0.8185	*****	
0.825	*****	-1.3084	-0.9027	-0.8119	-0.7024	
0.850	-1.2573	-1.2752	-0.8710	-0.7878	-0.6869	
0.875	*****	-1.2693	-0.8451	-0.7728	-0.6681	
0.900	-1.2423	-1.2785	-0.8128	-0.7566	-0.6472	
0.925	*****	-1.2759	-0.7940	-0.7342	-0.6370	
0.950	-1.2313	-1.2704	-0.7865	-0.7161	-0.5986	
0.975	*****	-1.2658	-0.7774	-0.6756	-0.5599	
1.000	-1.2926	-1.3028	-0.6826	-0.6468	-0.5212	
	$C_{p,l}$	$C_{p,l}$	$C_{p,l}$	$C_{p,l}$	$C_{p,l}$	$C_{p,l}$
-0.200	0.6083	0.5420	0.5056	*****	*****	-0.4525
-0.400	0.6118	0.5435	0.4799	0.2823	-0.4983	
-0.600	0.6118	0.5421	0.4689	0.2984	-0.4735	
-0.700	0.6013	0.5393	0.4696	0.3105	-0.4489	
-0.800	0.5577	0.5208	0.4586	0.3199	-0.3819	
-0.850	0.5109	0.4921	0.4427	0.3197	-0.3729	
-0.900	*****	0.4220	0.3947	0.3040	-0.3342	
-0.950	0.2252	0.2466	0.2449	0.2072	-0.1304	
-0.975	*****	0.0056	0.0384	0.0470	-0.1317	
-1.000	-1.2852	-1.3241	-0.7796	-0.6452	-0.5257	

Medium Radius L.E.
 Run No. = 9, Point No. = 191
 $C_N = 1.110$, $C_m = -0.1987$
 $\alpha = 24.6^\circ$, $M_\infty = 0.898$
 $R_{mac} = 6.0 \times 10^6$

Leading Edge Pressures

● starboard
 ○ port

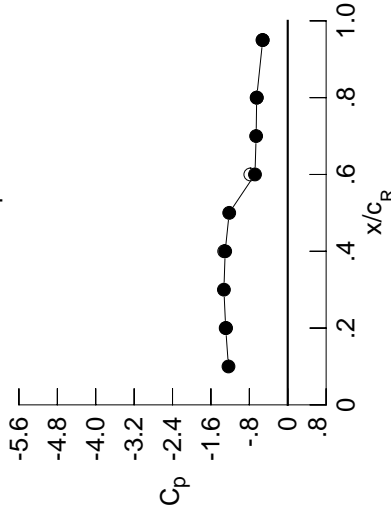

x/c_R	starb'd C_p	port C_p
0.10	-1.2348	*****
0.20	-1.2926	-1.2852
0.30	-1.3298	*****
0.40	-1.3028	-1.3241
0.50	-1.2193	*****
0.60	-0.6826	-0.7796
0.70	-0.6582	*****
0.80	-0.6468	-0.6452
0.90	*****	*****
0.95	-0.5212	-0.5257

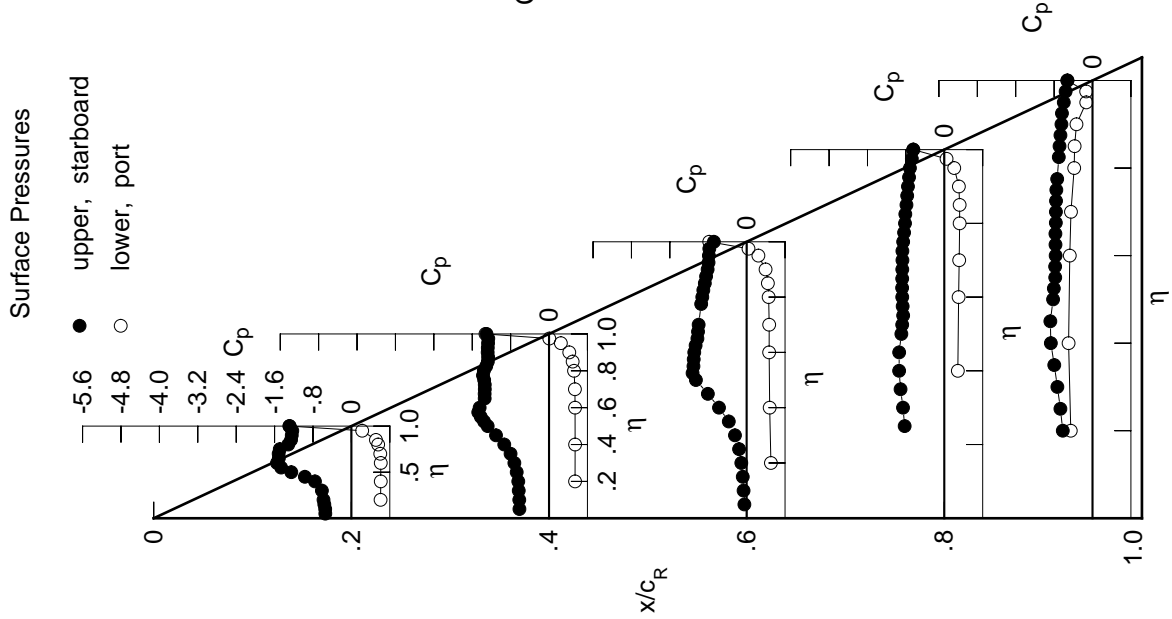
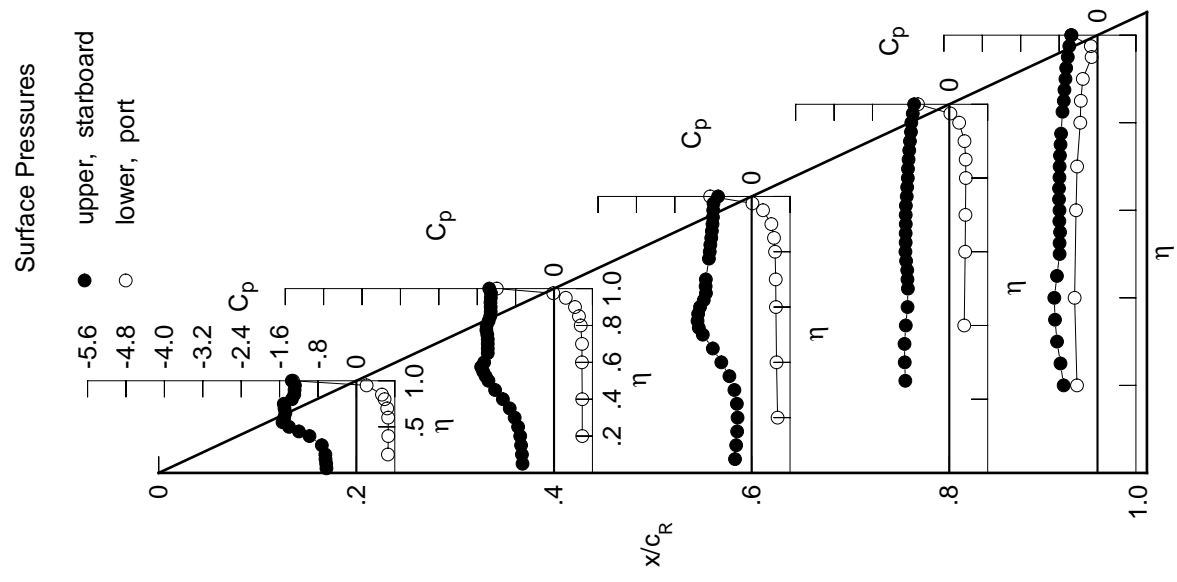
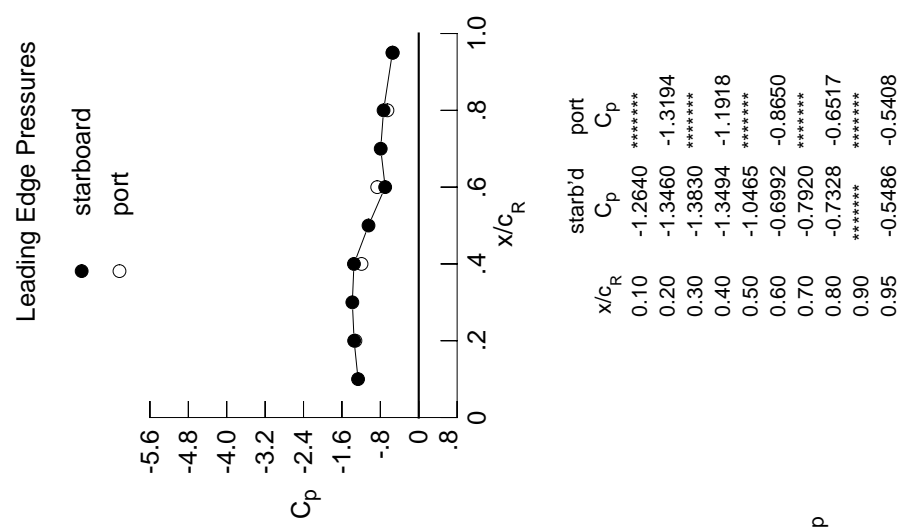

Table F4. Concluded.

η	$x/c_R = .2$		$x/c_R = .4$		$x/c_R = .6$		$x/c_R = .8$		$x/c_R = .95$	
	$C_{p,u}$	$C_{p,u}$	$C_{p,u}$	$C_{p,u}$	$C_{p,u}$	$C_{p,u}$	$C_{p,u}$	$C_{p,u}$	$C_{p,u}$	$C_{p,u}$
0.050	-0.6243	-0.6566	-0.3462	*****	*****	*****	*****	*****	*****	*****
0.100	-0.6294	-0.6688	-0.3221	*****	*****	*****	*****	*****	*****	*****
0.150	-0.6429	-0.6863	-0.3015	*****	*****	*****	*****	*****	*****	*****
0.200	-0.6463	-0.7051	-0.2935	*****	*****	*****	*****	*****	*****	-0.7057
0.250	*****	-0.7491	-0.3082	-0.9157	-0.9157	-0.9157	-0.9157	-0.9157	-0.9157	-0.7716
0.300	-0.7198	-0.8196	-0.3592	-0.9279	-0.9279	-0.9279	-0.9279	-0.9279	-0.9279	-0.8431
0.350	*****	-0.9229	-0.4635	-0.9324	-0.9324	-0.9324	-0.9324	-0.9324	-0.9324	-0.8853
0.400	-0.9770	-1.0655	-0.6318	-0.9066	-0.9066	-0.9066	-0.9066	-0.9066	-0.9066	-0.9004
0.450	-1.1980	-1.2280	-0.8090	-0.8699	-0.8699	-0.8699	-0.8699	-0.8699	-0.8699	-0.8451
0.500	-1.4044	-1.3661	-1.0179	-0.8625	-0.8625	-0.8625	-0.8625	-0.8625	-0.8625	-0.7900
0.525	*****	-1.4256	-1.1006	-0.8710	-0.8710	-0.8710	-0.8710	-0.8710	-0.8710	-0.7903
0.550	-1.5385	-1.4766	-1.1268	-0.8764	-0.8764	-0.8764	-0.8764	-0.8764	-0.8764	-0.7802
0.575	*****	-1.5183	-1.1141	-0.8998	-0.8998	-0.8998	-0.8998	-0.8998	-0.8998	-0.7953
0.600	-1.5037	-1.4557	-1.0755	-0.9137	-0.9137	-0.9137	-0.9137	-0.9137	-0.9137	-0.7923
0.625	*****	*****	-0.9977	-0.9084	-0.9084	-0.9084	-0.9084	-0.9084	-0.9084	-0.8015
0.650	-1.4804	-1.3805	-0.9518	-0.9085	-0.9085	-0.9085	-0.9085	-0.9085	-0.9085	-0.8014
0.675	*****	-1.3805	-0.9581	-0.9063	-0.9063	-0.9063	-0.9063	-0.9063	-0.9063	-0.7930
0.700	-1.4978	-1.3808	-0.9541	-0.9082	-0.9082	-0.9082	-0.9082	-0.9082	-0.9082	-0.7894
0.725	*****	-1.3806	*****	-0.9049	-0.9049	-0.9049	-0.9049	-0.9049	-0.9049	-0.7827
0.750	-1.5120	-1.3906	*****	-0.8863	-0.8863	-0.8863	-0.8863	-0.8863	-0.8863	-0.7701
0.775	*****	-1.4096	-0.8901	-0.8775	-0.8775	-0.8775	-0.8775	-0.8775	-0.8775	-0.7594
0.800	-1.3443	-1.4056	-0.8725	-0.8638	-0.8638	-0.8638	-0.8638	-0.8638	-0.8638	*****
0.825	*****	-1.3623	-0.8611	-0.8608	-0.8608	-0.8608	-0.8608	-0.8608	-0.8608	-0.7296
0.850	-1.2944	-1.3298	-0.8415	-0.8478	-0.8478	-0.8478	-0.8478	-0.8478	-0.8478	-0.7025
0.875	*****	-1.3191	-0.8292	-0.8347	-0.8347	-0.8347	-0.8347	-0.8347	-0.8347	-0.6889
0.900	-1.2881	-1.3200	-0.8154	-0.8200	-0.8200	-0.8200	-0.8200	-0.8200	-0.8200	-0.6678
0.925	*****	-1.3238	-0.8065	-0.7980	-0.7980	-0.7980	-0.7980	-0.7980	-0.7980	-0.6529
0.950	-1.2807	-1.3180	-0.8008	-0.7909	-0.7909	-0.7909	-0.7909	-0.7909	-0.7909	-0.6190
0.975	*****	-1.3135	-0.7943	-0.7610	-0.7610	-0.7610	-0.7610	-0.7610	-0.7610	-0.5882
1.000	-1.3460	-1.3494	-0.6992	-0.7328	-0.7328	-0.7328	-0.7328	-0.7328	-0.7328	-0.5486
	$C_{p,l}$	$C_{p,l}$	$C_{p,l}$	$C_{p,l}$	$C_{p,l}$	$C_{p,l}$	$C_{p,l}$	$C_{p,l}$	$C_{p,l}$	$C_{p,l}$
-0.200	0.6567	0.5879	0.5405	*****	*****	*****	*****	*****	*****	-0.4275
-0.400	0.6650	0.5875	0.5183	0.3112	0.3112	0.3112	0.3112	0.3112	0.3112	-0.4769
-0.600	0.6618	0.5810	0.5055	0.3310	0.3310	0.3310	0.3310	0.3310	0.3310	-0.4476
-0.700	0.6422	0.5825	0.5013	0.3372	0.3372	0.3372	0.3372	0.3372	0.3372	-0.4258
-0.800	0.5872	0.5557	0.4879	0.3445	0.3445	0.3445	0.3445	0.3445	0.3445	-0.3590
-0.850	0.5325	0.5189	0.4659	0.3416	0.3416	0.3416	0.3416	0.3416	0.3416	-0.3478
-0.900	*****	0.4372	0.4103	0.3170	0.3170	0.3170	0.3170	0.3170	0.3170	-0.3065
-0.950	0.2125	0.2438	0.2369	0.2053	0.2053	0.2053	0.2053	0.2053	0.2053	-0.1227
-0.975	*****	-0.0159	0.0162	0.0231	0.0231	0.0231	0.0231	0.0231	0.0231	-0.1392
-1.000	-1.3194	-1.1918	-0.8650	-0.6517	-0.6517	-0.6517	-0.6517	-0.6517	-0.6517	-0.5408

Medium Radius L.E.
 Run No. = 9, Point No. = 192
 $C_N = 1.172$, $C_m = -0.2049$
 $\alpha = 26.7^\circ$, $M_\infty = 0.899$
 $R_{mac} = 6.0 \times 10^6$



Appendix G

Experimental Surface Pressure Data for 65° Delta Wing, $R_{\text{mac}} = 60 \times 10^6$

The experimental surface pressure data for the 65° delta wing at constant $R_{\text{mac}} = 60 \times 10^6$ are summarized in tables G1–G4. Because of the extensive data contained in these tables, they have not been included in the printed copy of the paper but are available electronically from the Langley Technical Report Server (LTRS). Open the files with the following Uniform Resource Locator (URL):

<ftp://techreports.larc.nasa.gov/pub/techreports/larc/95/NASA-95-tm4645vol3appG.ps.Z>

Table G1. Tabulations and Plots of Surface Pressure Coefficients.

η	$x/c_R = .2$		$x/c_R = .4$		$x/c_R = .6$		$x/c_R = .8$		$x/c_R = .95$	
	$C_{p,u}$	$C_{p,u}$	$C_{p,u}$	$C_{p,u}$	$C_{p,u}$	$C_{p,u}$	$C_{p,u}$	$C_{p,u}$	$C_{p,u}$	$C_{p,u}$
0.050	0.0014	0.0162	0.1334	*****	*****	*****	*****	*****	*****	
0.100	0.0065	0.0164	0.1249	*****	*****	*****	*****	*****	*****	
0.150	0.0048	0.0163	0.1123	*****	*****	*****	*****	*****	*****	
0.200	0.0052	0.0218	0.0995	*****	*****	*****	*****	*****	*****	
0.250	*****	0.0166	0.0850	-0.1102	-0.3632	*****	*****	*****	*****	
0.300	-0.0059	0.0169	0.0785	-0.0989	-0.4125	*****	*****	*****	*****	
0.350	*****	0.0134	0.0665	-0.0892	-0.4293	*****	*****	*****	*****	
0.400	-0.0213	0.0148	0.0595	-0.0771	-0.4606	*****	*****	*****	*****	
0.450	-0.0268	0.0106	0.0686	-0.0724	-0.4707	*****	*****	*****	*****	
0.500	-0.0329	0.0110	0.0433	-0.0653	-0.4831	*****	*****	*****	*****	
0.525	*****	0.0067	0.0405	-0.0673	-0.4913	*****	*****	*****	*****	
0.550	-0.0333	0.0005	0.0385	-0.0616	-0.4885	*****	*****	*****	*****	
0.575	*****	-0.0030	0.0443	-0.0639	-0.5026	*****	*****	*****	*****	
0.600	-0.0396	-0.0040	0.0299	-0.0628	-0.4987	*****	*****	*****	*****	
0.625	*****	*****	0.0302	-0.0589	-0.4954	*****	*****	*****	*****	
0.650	-0.0380	-0.0056	0.0314	-0.0589	-0.4917	*****	*****	*****	*****	
0.675	*****	-0.0169	0.0184	-0.0583	-0.4757	*****	*****	*****	*****	
0.700	-0.0330	-0.0246	0.0167	-0.0575	-0.4612	*****	*****	*****	*****	
0.725	*****	-0.0310	*****	-0.0593	-0.4514	*****	*****	*****	*****	
0.750	-0.0257	-0.0372	*****	-0.0610	-0.4243	*****	*****	*****	*****	
0.775	*****	-0.0398	-0.0047	-0.0632	-0.4039	*****	*****	*****	*****	
0.800	-0.0059	-0.0432	-0.0153	-0.0659	*****	*****	*****	*****	*****	
0.825	*****	-0.0406	-0.0269	-0.0634	-0.4499	*****	*****	*****	*****	
0.850	0.0167	-0.0368	-0.0334	-0.0846	-0.4430	*****	*****	*****	*****	
0.875	*****	-0.0266	-0.0392	-0.0926	-0.6326	*****	*****	*****	*****	
0.900	0.0511	-0.0135	-0.0354	-0.0996	-0.7959	*****	*****	*****	*****	
0.925	*****	0.0098	-0.0214	-0.0935	-1.2707	*****	*****	*****	*****	
0.950	0.1014	0.0470	0.0115	-0.0619	-0.4163	*****	*****	*****	*****	
0.975	*****	0.1020	0.0684	-0.0010	-0.2112	*****	*****	*****	*****	
1.000	0.2176	0.2137	0.2006	0.1509	0.0901	*****	*****	*****	*****	
-0.200	$C_{p,l}$	$C_{p,l}$	$C_{p,l}$	$C_{p,l}$	$C_{p,l}$	$C_{p,l}$	$C_{p,l}$	$C_{p,l}$	$C_{p,l}$	
-0.400	-0.0259	-0.0032	0.0713	*****	-0.4049	*****	*****	*****	*****	
-0.600	-0.0524	-0.0051	0.0318	-0.0984	-0.4389	*****	*****	*****	*****	
-0.700	-0.0764	-0.0292	0.0039	-0.0872	-0.4874	*****	*****	*****	*****	
-0.800	-0.0784	-0.0651	-0.0240	-0.0854	-0.5486	*****	*****	*****	*****	
-0.850	-0.0645	*****	-0.0650	-0.0997	-0.6391	*****	*****	*****	*****	
-0.900	*****	-0.0983	-0.0970	-0.1307	-0.7326	*****	*****	*****	*****	
-0.950	*****	-0.0862	-0.1124	-0.1672	-0.6330	*****	*****	*****	*****	
-0.975	0.0338	-0.0390	-0.0825	-0.1572	-0.4314	*****	*****	*****	*****	
-1.000	0.0149	-0.0333	-0.1077	-0.2872	*****	*****	*****	*****	*****	
	0.1902	0.1863	0.1439	0.1326	0.0690	*****	*****	*****	*****	

Medium Radius L.E.
 Run No. = 24, Point No. = 481
 $C_N = -0.024$, $C_m = 0.0000$
 $\alpha = -0.7^\circ$, $M_\infty = 0.799$
 $R_{mac} = 59.3 \times 10^6$

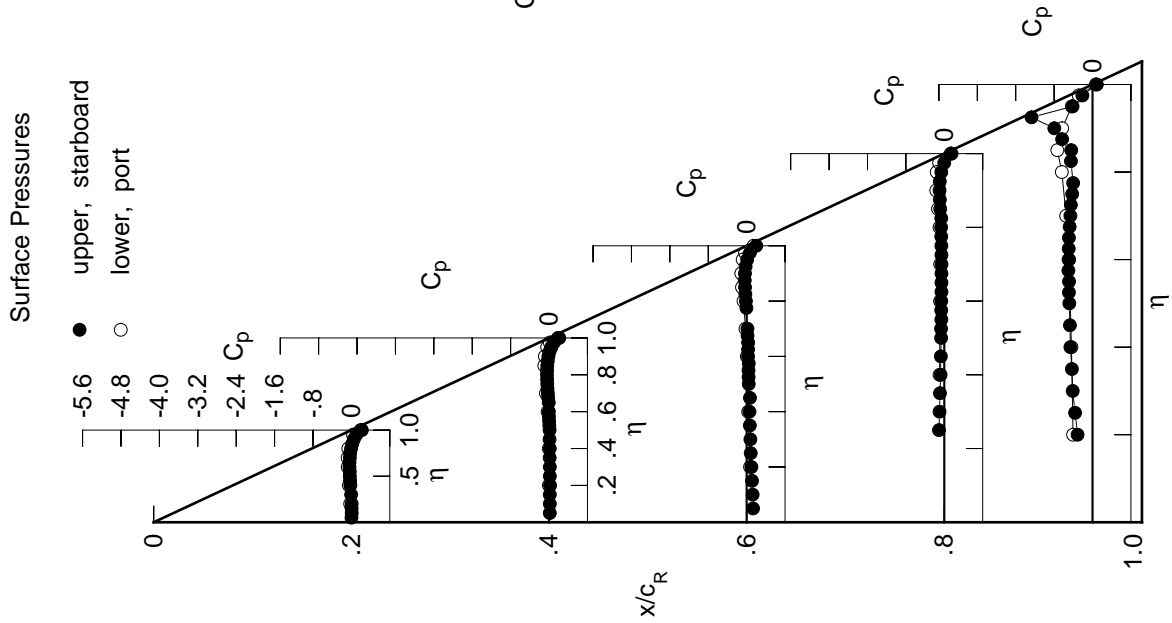

Leading Edge Pressures

- starboard
- port

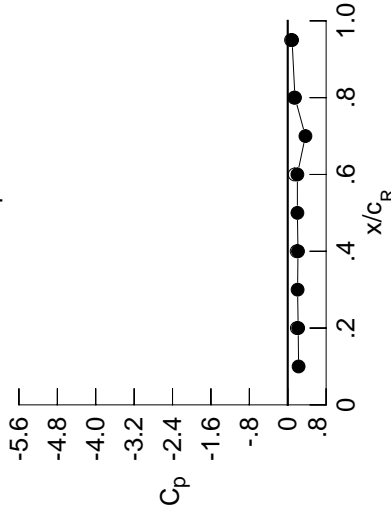

x/c_R	starb'd C_p	port C_p
0.10	0.2263	*****
0.20	0.2176	0.1902
0.30	0.2053	*****
0.40	0.2137	0.1863
0.50	0.2013	*****
0.60	0.2006	0.1439
0.70	0.3685	*****
0.80	0.1509	0.1326
0.90	*****	*****
0.95	0.0901	0.0690

Table G1. Continued.

η	$x/c_R = .2$		$x/c_R = .4$		$x/c_R = .6$		$x/c_R = .8$		$x/c_R = .95$	
	$C_{p,u}$	$C_{p,u}$	$C_{p,u}$	$C_{p,u}$	$C_{p,u}$	$C_{p,u}$	$C_{p,u}$	$C_{p,u}$	$C_{p,u}$	$C_{p,u}$
0.050	-0.0050	0.0109	0.1298	*****	*****	*****	*****	*****	*****	*****
0.100	-0.0007	0.0110	0.1208	*****	*****	*****	*****	*****	*****	*****
0.150	-0.0010	0.0116	0.1084	*****	*****	*****	*****	*****	*****	*****
0.200	-0.0014	0.0161	0.0951	*****	*****	*****	*****	*****	*****	*****
0.250	*****	0.0116	0.0816	-0.1140	-0.3568	*****	*****	*****	*****	*****
0.300	-0.0130	0.0111	0.0735	-0.1020	-0.4065	*****	*****	*****	*****	*****
0.350	*****	0.0086	0.0626	-0.0924	-0.4243	*****	*****	*****	*****	*****
0.400	-0.0293	0.0080	0.0544	-0.0806	-0.4557	*****	*****	*****	*****	*****
0.450	-0.0353	0.0045	0.0629	-0.0761	-0.4665	*****	*****	*****	*****	*****
0.500	-0.0421	0.0028	0.0386	-0.0691	-0.4774	*****	*****	*****	*****	*****
0.525	*****	0.0009	0.0349	-0.0706	-0.4859	*****	*****	*****	*****	*****
0.550	-0.0432	-0.0056	0.0338	-0.0657	-0.4827	*****	*****	*****	*****	*****
0.575	*****	-0.0091	0.0387	-0.0681	-0.4970	*****	*****	*****	*****	*****
0.600	-0.0501	-0.0125	0.0243	-0.0662	-0.4916	*****	*****	*****	*****	*****
0.625	*****	*****	0.0245	-0.0646	-0.4887	*****	*****	*****	*****	*****
0.650	-0.0491	-0.0144	0.0240	-0.0646	-0.4821	*****	*****	*****	*****	*****
0.675	*****	-0.0263	0.0127	-0.0628	-0.4640	*****	*****	*****	*****	*****
0.700	-0.0450	-0.0340	0.0088	-0.0640	-0.4480	*****	*****	*****	*****	*****
0.725	*****	-0.0421	*****	-0.0659	-0.4352	*****	*****	*****	*****	*****
0.750	-0.0380	-0.0492	*****	-0.0678	-0.4040	*****	*****	*****	*****	*****
0.775	*****	-0.0518	-0.0149	-0.0711	-0.3771	*****	*****	*****	*****	*****
0.800	-0.0192	-0.0566	-0.0272	-0.0747	*****	*****	*****	*****	*****	*****
0.825	*****	-0.0549	-0.0377	-0.0716	-0.4205	*****	*****	*****	*****	*****
0.850	0.0027	-0.0515	-0.0472	-0.0951	-0.4183	*****	*****	*****	*****	*****
0.875	*****	-0.0424	-0.0552	-0.1056	-0.5929	*****	*****	*****	*****	*****
0.900	0.0369	-0.0307	-0.0520	-0.1146	-0.7914	*****	*****	*****	*****	*****
0.925	*****	-0.0085	-0.0405	-0.1105	-1.2810	*****	*****	*****	*****	*****
0.950	0.0863	0.0280	-0.0087	-0.0806	-0.4275	*****	*****	*****	*****	*****
0.975	*****	0.0828	0.0473	-0.0235	-0.2284	*****	*****	*****	*****	*****
1.000	0.2204	0.2197	0.2171	0.1640	0.0986	*****	*****	*****	*****	*****
η	$C_{p,l}$	$C_{p,l}$	$C_{p,l}$	$C_{p,l}$	$C_{p,l}$	$C_{p,l}$	$C_{p,l}$	$C_{p,l}$	$C_{p,l}$	$C_{p,l}$
-0.200	-0.0198	0.0029	0.0744	*****	-0.4072	*****	*****	*****	*****	*****
-0.400	-0.0451	-0.0001	0.0370	-0.0944	-0.4435	*****	*****	*****	*****	*****
-0.600	-0.0667	-0.0208	0.0090	-0.0823	-0.4924	*****	*****	*****	*****	*****
-0.700	-0.0668	-0.0556	-0.0162	-0.0802	-0.5600	*****	*****	*****	*****	*****
-0.800	-0.0511	*****	-0.0547	-0.0920	-0.6604	*****	*****	*****	*****	*****
-0.850	*****	-0.0822	-0.0837	-0.1205	-0.7622	*****	*****	*****	*****	*****
-0.900	*****	-0.0677	-0.0947	-0.1522	-0.7246	*****	*****	*****	*****	*****
-0.950	0.0514	-0.0180	-0.0600	-0.1353	-0.4204	*****	*****	*****	*****	*****
-0.975	*****	0.0387	-0.0077	-0.0819	-0.2688	*****	*****	*****	*****	*****
-1.000	0.1963	0.1952	0.1577	0.1510	0.0807	*****	*****	*****	*****	*****

Medium Radius L.E.
 Run No. = 24 , Point No. = 482
 $C_N = -0.012$, $C_m = -0.0009$
 $\alpha = -0.4^\circ$, $M_\infty = 0.799$
 $R_{mac} = 59.4 \times 10^6$

Leading Edge Pressures

- starboard
- port

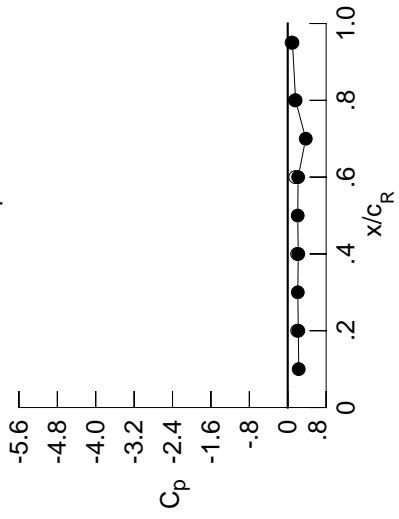

x/c_R	starb'd C_p	port C_p
0.10	0.2291	*****
0.20	0.2204	0.1963
0.30	0.2100	*****
0.40	0.2197	0.1952
0.50	0.2078	*****
0.60	0.2171	0.1577
0.70	0.3751	*****
0.80	0.1640	0.1510
0.90	*****	*****
0.95	0.0986	0.0807

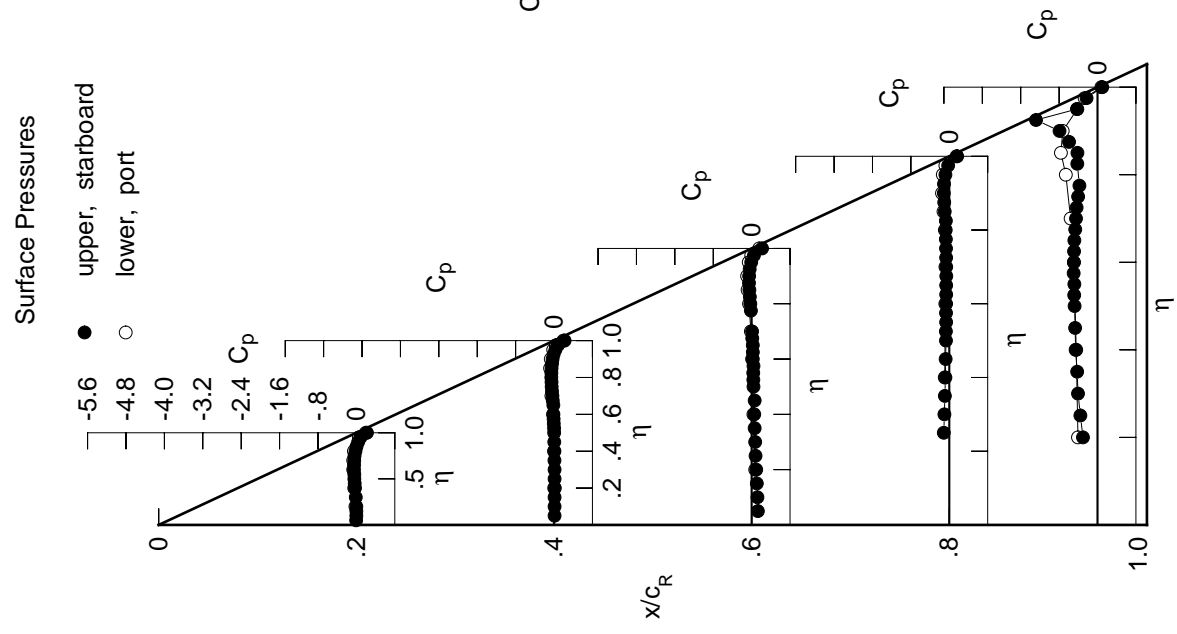

Table G1. Continued.

η	x/c_R .2	x/c_R .4	x/c_R .6	x/c_R .8	x/c_R .95
	$C_{p,u}$	$C_{p,u}$	$C_{p,u}$	$C_{p,u}$	$C_{p,u}$
0.050	-0.0238	-0.0050	0.1182	*****	*****
0.100	-0.0183	-0.0042	0.1107	*****	*****
0.150	-0.0198	-0.0046	0.0977	*****	*****
0.200	-0.0202	-0.0016	0.0843	*****	-0.2951
0.250	*****	-0.0053	0.0697	-0.1215	-0.3450
0.300	-0.0330	-0.0057	0.0627	-0.1102	-0.3941
0.350	*****	-0.0098	0.0498	-0.1014	-0.4114
0.400	-0.0520	-0.0086	0.0415	-0.0900	-0.4407
0.450	-0.0591	-0.0139	0.0498	-0.0853	-0.4501
0.500	-0.0675	-0.0153	0.0245	-0.0789	-0.4603
0.525	*****	-0.0200	0.0202	-0.0815	-0.4678
0.550	-0.0701	-0.0264	0.0196	-0.0769	-0.4647
0.575	*****	-0.0318	0.0225	-0.0801	-0.4750
0.600	-0.0794	-0.0344	0.0081	-0.0792	-0.4714
0.625	*****	*****	0.0069	-0.0770	-0.4667
0.650	-0.0808	-0.0386	0.0074	-0.0771	-0.4581
0.675	*****	-0.0533	-0.0068	-0.0791	-0.4390
0.700	-0.0795	-0.0627	-0.0113	-0.0788	-0.4211
0.725	*****	-0.0730	*****	-0.0831	-0.4005
0.750	-0.0746	-0.0815	*****	-0.0855	-0.3601
0.775	*****	-0.0887	-0.0426	-0.0915	-0.3192
0.800	-0.0587	-0.0952	-0.0580	-0.0976	*****
0.825	*****	-0.0978	-0.0735	-0.0978	-0.3552
0.850	-0.0392	-0.0975	-0.0881	-0.1260	-0.3687
0.875	*****	-0.0923	-0.0998	-0.1424	-0.5185
0.900	-0.0087	-0.0839	-0.1046	-0.1596	-0.7667
0.925	*****	-0.0669	-0.0977	-0.1632	-1.3081
0.950	0.0372	-0.0336	-0.0748	-0.1434	-0.4632
0.975	*****	0.0169	-0.0243	-0.0944	-0.2830
1.000	0.2142	0.2100	0.2112	0.1554	0.0932
	$C_{p,l}$	$C_{p,l}$	$C_{p,l}$	$C_{p,l}$	$C_{p,l}$
-0.200	0.0017	0.0219	0.0889	*****	-0.4176
-0.400	-0.0217	0.0217	0.0540	-0.0824	-0.4557
-0.600	-0.0362	0.0033	0.0299	-0.0659	-0.5138
-0.700	-0.0318	-0.0252	0.0076	-0.0613	-0.5981
-0.800	-0.0101	*****	-0.0226	-0.0666	-0.6974
-0.850	*****	-0.0368	-0.0432	-0.0873	-0.7674
-0.900	*****	-0.0150	-0.0431	-0.1059	-0.8421
-0.950	0.0999	0.0415	0.0037	-0.0721	-0.3880
-0.975	*****	0.1025	0.0620	-0.0095	-0.2180
-1.000	0.1953	0.1942	0.1561	0.1582	0.0884

Medium Radius L.E.
 Run No. = 24 , Point No. = 483
 $C_N = 0.027$, $C_m = -0.0065$
 $\alpha = 0.7^\circ$, $M_\infty = 0.798$
 $R_{mac} = 59.5 \times 10^6$

Leading Edge Pressures

● starboard
 ○ port

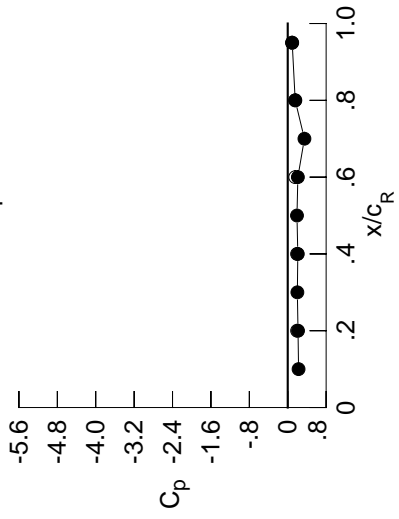

x/c_R	starb'd C_p	port C_p
0.10	0.2258	*****
0.20	0.2142	0.1953
0.30	0.2004	*****
0.40	0.2100	0.1942
0.50	0.1924	*****
0.60	0.2112	0.1561
0.70	0.3477	*****
0.80	0.1554	0.1582
0.90	*****	*****
0.95	0.0932	0.0884

Surface Pressures

● upper, starboard
 ○ lower, port

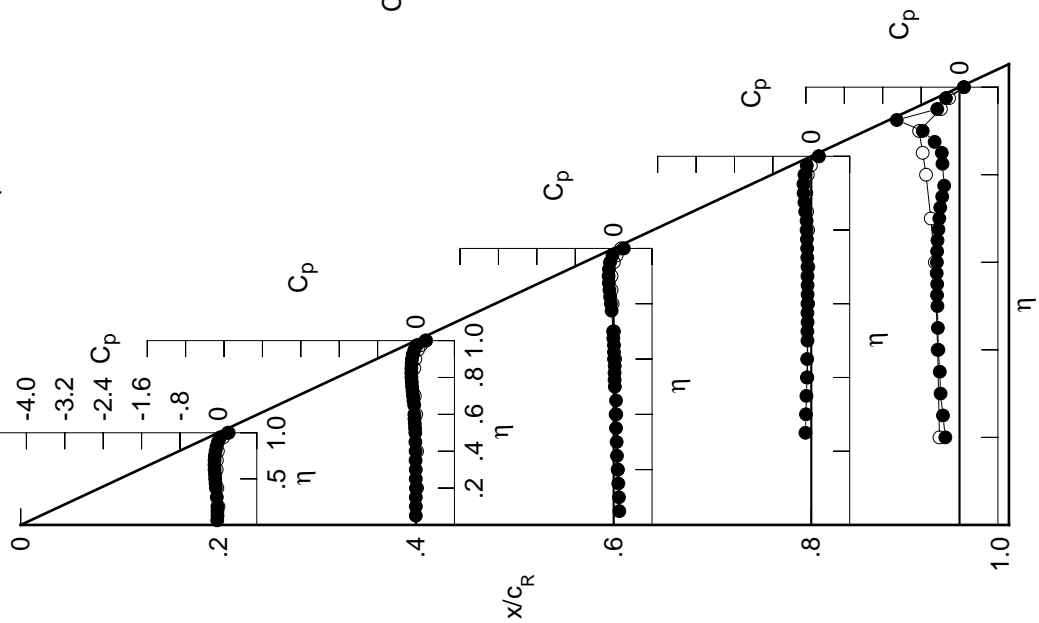

Table G1. Continued.

η	$x/c_R = .2$		$x/c_R = .4$		$x/c_R = .6$		$x/c_R = .8$		$x/c_R = .95$	
	$C_{p,u}$	$C_{p,u}$	$C_{p,u}$	$C_{p,u}$	$C_{p,u}$	$C_{p,u}$	$C_{p,u}$	$C_{p,u}$	$C_{p,u}$	$C_{p,u}$
0.050	-0.0433	-0.0200	0.1070	*****	*****	*****	*****	*****	*****	
0.100	-0.0370	-0.0205	0.0989	*****	*****	*****	*****	*****	*****	
0.150	-0.0384	-0.0206	0.0857	*****	*****	*****	*****	*****	*****	
0.200	-0.0397	-0.0170	0.0727	*****	*****	*****	*****	*****	-0.2791	
0.250	*****	-0.0211	0.0579	-0.1308	-0.1308	-0.3285	*****	*****	*****	
0.300	-0.0526	-0.0228	0.0499	-0.1193	-0.3787	*****	*****	*****	*****	
0.350	*****	-0.0273	0.0370	-0.1103	-0.3968	*****	*****	*****	*****	
0.400	-0.0749	-0.0272	0.0276	-0.1005	-0.4266	*****	*****	*****	*****	
0.450	-0.0843	-0.0330	0.0359	-0.0959	-0.4358	*****	*****	*****	*****	
0.500	-0.0934	-0.0354	0.0086	-0.0907	-0.4451	*****	*****	*****	*****	
0.525	*****	-0.0407	0.0044	-0.0929	-0.4512	*****	*****	*****	*****	
0.550	-0.0983	-0.0489	0.0014	-0.0898	-0.4491	*****	*****	*****	*****	
0.575	*****	-0.0543	0.0059	-0.0923	-0.4581	*****	*****	*****	*****	
0.600	-0.1098	-0.0578	-0.0112	-0.0934	-0.4539	*****	*****	*****	*****	
0.625	*****	*****	-0.0112	-0.0911	-0.4498	*****	*****	*****	*****	
0.650	-0.1148	-0.0659	-0.0130	-0.0925	-0.4402	*****	*****	*****	*****	
0.675	*****	-0.0808	-0.0278	-0.0952	-0.4193	*****	*****	*****	*****	
0.700	-0.1161	-0.0927	-0.0341	-0.0964	-0.3990	*****	*****	*****	*****	
0.725	*****	-0.1061	*****	-0.1016	-0.3725	*****	*****	*****	*****	
0.750	-0.1142	-0.1178	*****	-0.1057	-0.3258	*****	*****	*****	*****	
0.775	*****	-0.1272	-0.0712	-0.1152	-0.2728	*****	*****	*****	*****	
0.800	-0.1017	-0.1380	-0.0910	-0.1229	*****	*****	*****	*****	*****	
0.825	*****	-0.1441	-0.1118	-0.1258	-0.3007	*****	*****	*****	*****	
0.850	-0.0863	-0.1478	-0.1322	-0.1598	-0.3277	*****	*****	*****	*****	
0.875	*****	-0.1484	-0.1497	-0.1835	-0.4643	*****	*****	*****	*****	
0.900	-0.0605	-0.1436	-0.1631	-0.2097	-0.6986	*****	*****	*****	*****	
0.925	*****	-0.1336	-0.1648	-0.2246	-1.3308	*****	*****	*****	*****	
0.950	-0.0200	-0.1060	-0.1514	-0.2156	-0.5054	*****	*****	*****	*****	
0.975	*****	-0.0666	-0.1140	-0.1838	-0.3475	*****	*****	*****	*****	
1.000	0.1804	0.1486	0.1284	0.0699	0.0366	*****	*****	*****	*****	
-0.200	$C_{p,l}$	$C_{p,l}$	$C_{p,l}$	$C_{p,l}$	$C_{p,l}$	$C_{p,l}$	$C_{p,l}$	$C_{p,l}$	$C_{p,l}$	
-0.400	0.0234	0.0414	0.1035	*****	-0.4228	*****	*****	*****	*****	
-0.600	0.0033	0.0429	0.0691	-0.0693	-0.4693	*****	*****	*****	*****	
-0.700	-0.0055	0.0287	0.0490	-0.0503	-0.5415	*****	*****	*****	*****	
-0.800	0.0034	0.0044	0.0307	-0.0419	-0.6353	*****	*****	*****	*****	
-0.850	0.0293	*****	0.0078	-0.0420	-0.6948	*****	*****	*****	*****	
-0.900	*****	0.0071	-0.0037	-0.0559	-0.7474	*****	*****	*****	*****	
-0.950	0.1425	0.0934	0.0041	-0.0628	-0.8031	*****	*****	*****	*****	
-0.975	*****	0.1536	0.0591	-0.0165	-0.3553	*****	*****	*****	*****	
-1.000	0.1652	0.1417	0.0846	0.0892	0.0471	*****	*****	*****	*****	

Medium Radius L.E.
 Run No. = 24 , Point No. = 484
 $C_N = 0.065$, $C_m = -0.0100$
 $\alpha = 1.8^\circ$, $M_\infty = 0.798$
 $R_{mac} = 59.4 \times 10^6$

Leading Edge Pressures

● starboard
 ○ port

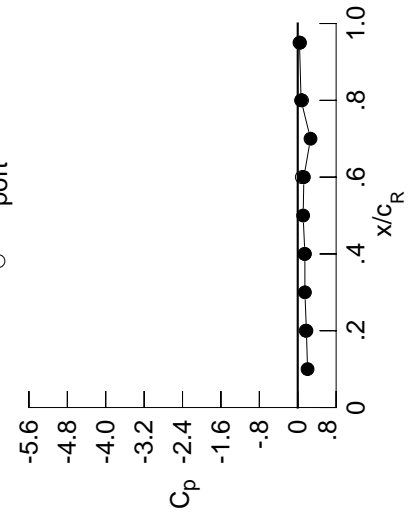

x/c_R	starb'd C_p	port C_p
0.10	0.2049	*****
0.20	0.1804	0.1652
0.30	0.1497	*****
0.40	0.1486	0.1417
0.50	0.1128	*****
0.60	0.1284	0.0846
0.70	0.2663	*****
0.80	0.0699	0.0892
0.90	*****	*****
0.95	0.0366	0.0471

Surface Pressures

● upper, starboard
 ○ lower, port

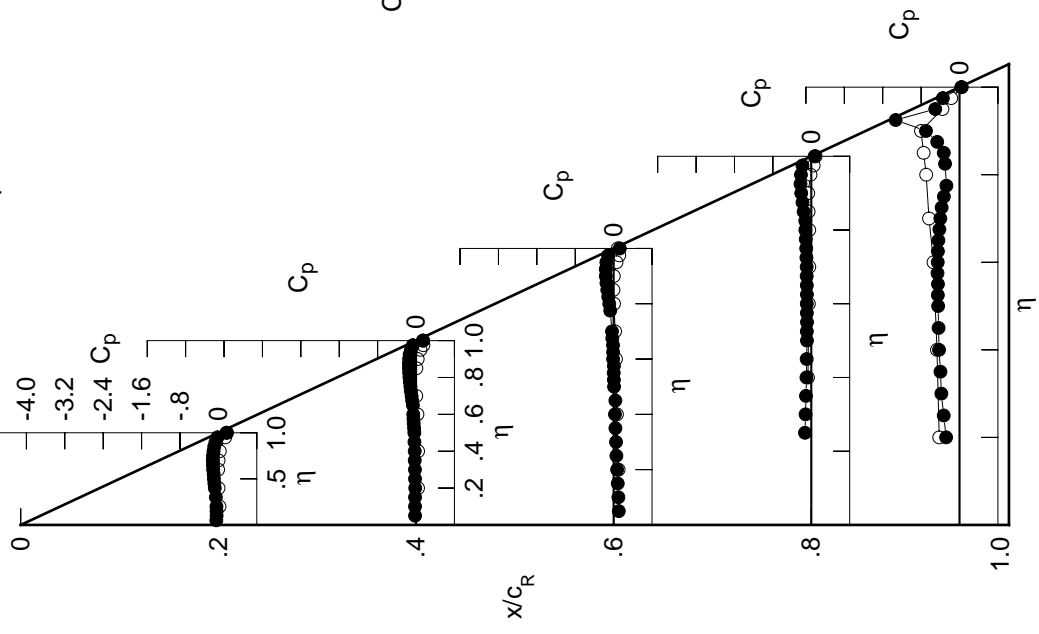

Table G1. Continued.

η	$x/c_R = .2$		$x/c_R = .4$		$x/c_R = .6$		$x/c_R = .8$		$x/c_R = .95$	
	$C_{p,u}$	$C_{p,u}$	$C_{p,u}$	$C_{p,u}$	$C_{p,u}$	$C_{p,u}$	$C_{p,u}$	$C_{p,u}$	$C_{p,u}$	$C_{p,u}$
0.050	-0.0630	-0.0382	0.0946	*****	*****	*****	*****	*****	*****	
0.100	-0.0578	-0.0382	0.0859	*****	*****	*****	*****	*****	*****	
0.150	-0.0589	-0.0388	0.0732	*****	*****	*****	*****	*****	*****	
0.200	-0.0603	-0.0351	0.0593	*****	*****	*****	*****	*****	-0.2897	
0.250	*****	-0.0405	0.0442	-0.1414	-0.3307	*****	*****	*****	*****	
0.300	-0.0741	-0.0415	0.0358	-0.1298	-0.3725	*****	*****	*****	*****	
0.350	*****	-0.0468	0.0228	-0.1229	-0.3882	*****	*****	*****	*****	
0.400	-0.0981	-0.0479	0.0124	-0.1117	-0.4155	*****	*****	*****	*****	
0.450	-0.1093	-0.0533	0.0202	-0.1080	-0.4248	*****	*****	*****	*****	
0.500	-0.1208	-0.0572	-0.0080	-0.1031	-0.4345	*****	*****	*****	*****	
0.525	*****	-0.0630	-0.0128	-0.1058	-0.4401	*****	*****	*****	*****	
0.550	-0.1282	-0.0720	-0.0165	-0.1037	-0.4374	*****	*****	*****	*****	
0.575	*****	-0.0787	-0.0127	-0.1074	-0.4472	*****	*****	*****	*****	
0.600	-0.1415	-0.0835	-0.0304	-0.1078	-0.4421	*****	*****	*****	*****	
0.625	*****	*****	-0.0310	-0.1071	-0.4374	*****	*****	*****	*****	
0.650	-0.1494	-0.0927	-0.0337	-0.1086	-0.4263	*****	*****	*****	*****	
0.675	*****	-0.1110	-0.0505	-0.1127	-0.4049	*****	*****	*****	*****	
0.700	-0.1543	-0.1243	-0.0580	-0.1152	-0.3806	*****	*****	*****	*****	
0.725	*****	-0.1397	*****	-0.1210	-0.3506	*****	*****	*****	*****	
0.750	-0.1558	-0.1544	*****	-0.1283	-0.2965	*****	*****	*****	*****	
0.775	*****	-0.1681	-0.1026	-0.1379	-0.2370	*****	*****	*****	*****	
0.800	-0.1472	-0.1820	-0.1257	-0.1503	*****	*****	*****	*****	*****	
0.825	*****	-0.1922	-0.1517	-0.1549	-0.2600	*****	*****	*****	*****	
0.850	-0.1361	-0.2007	-0.1776	-0.1944	-0.2928	*****	*****	*****	*****	
0.875	*****	-0.2070	-0.2039	-0.2266	-0.4224	*****	*****	*****	*****	
0.900	-0.1172	-0.2091	-0.2241	-0.2626	-0.6295	*****	*****	*****	*****	
0.925	*****	-0.2054	-0.2367	-0.2885	-1.3176	*****	*****	*****	*****	
0.950	-0.0845	-0.1862	-0.2356	-0.2975	-0.5484	*****	*****	*****	*****	
0.975	*****	-0.1640	-0.2162	-0.2850	-0.4201	*****	*****	*****	*****	
1.000	0.1161	0.0393	-0.0159	-0.0850	-0.0680	*****	*****	*****	*****	
-0.200	$C_{p,l}$	$C_{p,l}$	$C_{p,l}$	$C_{p,l}$	$C_{p,l}$	$C_{p,l}$	$C_{p,l}$	$C_{p,l}$	$C_{p,l}$	
-0.400	0.0433	0.0575	0.1160	*****	-0.4390	*****	*****	*****	*****	
-0.600	0.0247	0.0602	0.0819	-0.0577	-0.4900	*****	*****	*****	*****	
-0.700	0.0212	0.0497	0.0660	-0.0373	-0.5824	*****	*****	*****	*****	
-0.800	0.0337	0.0300	0.0507	-0.0263	-0.6832	*****	*****	*****	*****	
-0.850	0.0629	*****	0.0349	-0.0215	-0.6909	*****	*****	*****	*****	
-0.900	*****	0.0441	0.0289	-0.0292	-0.7287	*****	*****	*****	*****	
-0.950	*****	0.0754	0.0437	-0.0259	-0.7663	*****	*****	*****	*****	
-0.975	0.1741	0.1327	0.1019	0.0284	-0.3271	*****	*****	*****	*****	
-1.000	*****	0.1860	0.1552	0.0913	-0.1339	*****	*****	*****	*****	
	0.1027	0.0372	-0.0599	-0.0522	-0.0443	*****	*****	*****	*****	

Medium Radius L.E.
 Run No. = 24 , Point No. = 485
 $C_N = 0.105$, $C_m = -0.0170$
 $\alpha = 2.8^\circ$, $M_\infty = 0.799$
 $R_{mac} = 59.5 \times 10^6$

Leading Edge Pressures

● starboard
 ○ port

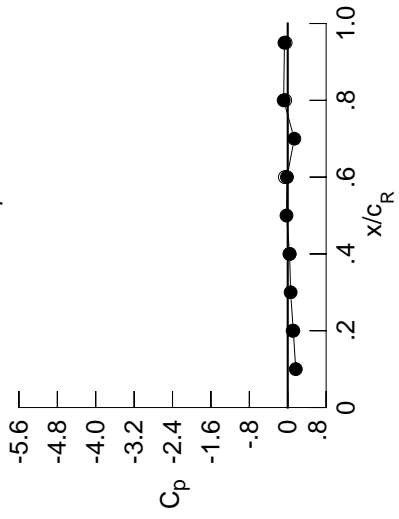

x/c_R	starb'd C_p	port C_p
0.10	0.1668	*****
0.20	0.1161	0.1027
0.30	0.0598	*****
0.40	0.0393	0.0372
0.50	-0.0253	*****
0.60	-0.0159	-0.0599
0.70	0.1366	*****
0.80	-0.0850	-0.0522
0.90	*****	*****
0.95	-0.0680	-0.0443

Surface Pressures
 ● upper, starboard
 ○ lower, port

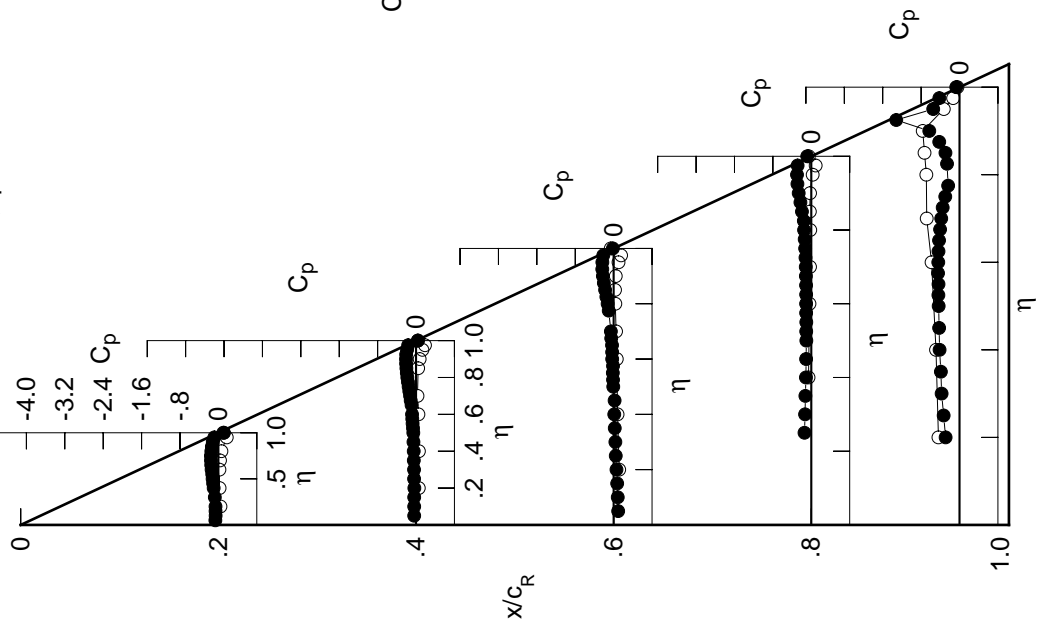
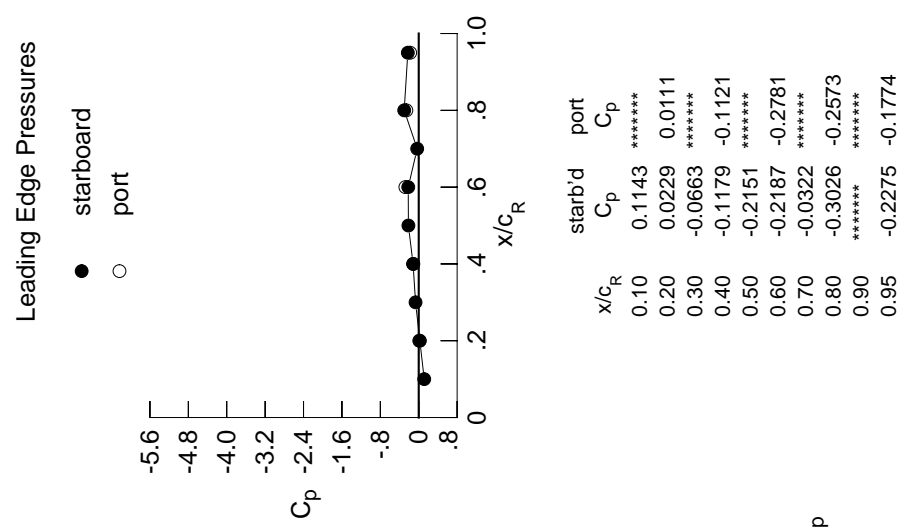

Table G1. Continued.

η	$x/c_R = .2$		$x/c_R = .4$		$x/c_R = .6$		$x/c_R = .8$		$x/c_R = .95$	
	$C_{p,u}$	$C_{p,l}$	$C_{p,u}$	$C_{p,l}$	$C_{p,u}$	$C_{p,l}$	$C_{p,u}$	$C_{p,l}$	$C_{p,u}$	$C_{p,l}$
0.050	-0.0802	-0.0539	0.0837	*****	*****	*****	*****	*****	*****	*****
0.100	-0.0758	-0.0530	0.0757	*****	*****	*****	*****	*****	*****	*****
0.150	-0.0776	-0.0547	0.0621	*****	*****	*****	*****	*****	*****	*****
0.200	-0.0777	-0.0500	0.0489	*****	*****	*****	*****	*****	*****	*****
0.250	*****	-0.0557	0.0314	-0.1501	-0.1501	-0.1501	-0.1501	-0.1501	-0.1501	-0.1501
0.300	-0.0933	-0.0571	0.0245	-0.1391	-0.1391	-0.1391	-0.1391	-0.1391	-0.1391	-0.1391
0.350	*****	-0.0648	0.0104	-0.1300	-0.1300	-0.1300	-0.1300	-0.1300	-0.1300	-0.1300
0.400	-0.1196	-0.0649	-0.0011	-0.1205	-0.1205	-0.1205	-0.1205	-0.1205	-0.1205	-0.1205
0.450	-0.1325	-0.0725	0.0052	-0.1172	-0.1172	-0.1172	-0.1172	-0.1172	-0.1172	-0.1172
0.500	-0.1454	-0.0772	-0.0233	-0.1141	-0.1141	-0.1141	-0.1141	-0.1141	-0.1141	-0.1141
0.525	*****	-0.0838	-0.0282	-0.1169	-0.1169	-0.1169	-0.1169	-0.1169	-0.1169	-0.1169
0.550	-0.1554	-0.0932	-0.0326	-0.1156	-0.1156	-0.1156	-0.1156	-0.1156	-0.1156	-0.1156
0.575	*****	-0.1016	-0.0297	-0.1190	-0.1190	-0.1190	-0.1190	-0.1190	-0.1190	-0.1190
0.600	-0.1714	-0.1069	-0.0488	-0.1205	-0.1205	-0.1205	-0.1205	-0.1205	-0.1205	-0.1205
0.625	*****	*****	-0.0501	-0.1198	-0.1198	-0.1198	-0.1198	-0.1198	-0.1198	-0.1198
0.650	-0.1833	-0.1179	0.0542	-0.1224	-0.1224	-0.1224	-0.1224	-0.1224	-0.1224	-0.1224
0.675	*****	-0.1373	-0.0720	-0.1274	-0.1274	-0.1274	-0.1274	-0.1274	-0.1274	-0.1274
0.700	-0.1907	-0.1541	-0.0804	-0.1311	-0.1311	-0.1311	-0.1311	-0.1311	-0.1311	-0.1311
0.725	*****	-0.1725	*****	-0.1400	-0.1400	-0.1400	-0.1400	-0.1400	-0.1400	-0.1400
0.750	-0.1968	-0.1899	*****	-0.1485	-0.1485	-0.1485	-0.1485	-0.1485	-0.1485	-0.1485
0.775	*****	-0.2075	-0.1321	-0.1613	-0.1613	-0.1613	-0.1613	-0.1613	-0.1613	-0.1613
0.800	-0.1930	-0.2260	-0.1592	-0.1755	-0.1755	-0.1755	-0.1755	-0.1755	-0.1755	-0.1755
0.825	*****	-0.2416	-0.1905	-0.1826	-0.1826	-0.1826	-0.1826	-0.1826	-0.1826	-0.1826
0.850	-0.1879	-0.2553	-0.2226	-0.2289	-0.2289	-0.2289	-0.2289	-0.2289	-0.2289	-0.2289
0.875	*****	-0.2670	-0.2581	-0.2686	-0.2686	-0.2686	-0.2686	-0.2686	-0.2686	-0.2686
0.900	-0.1759	-0.2761	-0.2882	-0.3154	-0.3154	-0.3154	-0.3154	-0.3154	-0.3154	-0.3154
0.925	*****	-0.2814	-0.3123	-0.3558	-1.1849	-1.1849	-1.1849	-1.1849	-1.1849	-1.1849
0.950	-0.1547	-0.2734	-0.3263	-0.3811	-0.3811	-0.3811	-0.3811	-0.3811	-0.3811	-0.3811
0.975	*****	-0.2720	-0.3317	-0.3967	-0.4989	-0.4989	-0.4989	-0.4989	-0.4989	-0.4989
1.000	0.0229	-0.1179	-0.2187	-0.3026	-0.2275	-0.2275	-0.2275	-0.2275	-0.2275	-0.2275
-0.200	$C_{p,l}$	$C_{p,l}$	$C_{p,l}$	$C_{p,l}$	$C_{p,l}$	$C_{p,l}$	$C_{p,l}$	$C_{p,l}$	$C_{p,l}$	$C_{p,l}$
-0.400	0.0652	0.0773	0.1307	*****	*****	*****	*****	*****	*****	*****
-0.600	0.0487	0.0802	0.0990	-0.0447	-0.5029	-0.5029	-0.5029	-0.5029	-0.5029	-0.5029
-0.700	0.0498	0.0730	0.0849	-0.0223	-0.6014	-0.6014	-0.6014	-0.6014	-0.6014	-0.6014
-0.800	0.0646	0.0568	0.0723	-0.0092	-0.6865	-0.6865	-0.6865	-0.6865	-0.6865	-0.6865
-0.850	0.0966	*****	0.0612	0.0009	-0.6751	-0.6751	-0.6751	-0.6751	-0.6751	-0.6751
-0.900	*****	0.0804	0.0616	-0.0026	-0.7060	-0.7060	-0.7060	-0.7060	-0.7060	-0.7060
-0.950	*****	0.1135	0.0812	0.0086	-0.7315	-0.7315	-0.7315	-0.7315	-0.7315	-0.7315
-0.975	0.2006	0.1661	0.1387	0.0670	-0.3007	-0.3007	-0.3007	-0.3007	-0.3007	-0.3007
-1.000	0.0111	-0.1121	-0.2781	-0.2573	-0.1774	-0.1774	-0.1774	-0.1774	-0.1774	-0.1774

Medium Radius L.E.
 Run No. = 24 , Point No. = 486
 $C_N = 0.143$, $C_m = -0.0218$
 $\alpha = 3.9^\circ$, $M_\infty = 0.798$
 $R_{mac} = 59.6 \times 10^6$



x/c_R	starb'd C_p	port C_p
0.10	0.1143	*****
0.20	0.0229	0.0111
0.30	-0.0663	*****
0.40	-0.1179	-0.1121
0.50	-0.2151	*****
0.60	-0.2187	-0.2781
0.70	-0.0322	*****
0.80	-0.3026	-0.2573
0.90	*****	*****
0.95	-0.2275	-0.1774

Table G1. Continued.

η	$x/c_R = .2$		$x/c_R = .4$		$x/c_R = .6$		$x/c_R = .8$		$x/c_R = .95$	
	$C_{p,u}$	$C_{p,u}$	$C_{p,u}$	$C_{p,u}$	$C_{p,u}$	$C_{p,u}$	$C_{p,u}$	$C_{p,u}$	$C_{p,u}$	$C_{p,u}$
0.050	-0.0999	-0.0706	0.0725	*****	*****	*****	*****	*****	*****	*****
0.100	-0.0956	-0.0691	0.0643	*****	*****	*****	*****	*****	*****	*****
0.150	-0.0968	-0.0715	0.0502	*****	*****	*****	*****	*****	*****	*****
0.200	-0.0984	-0.0671	0.0365	*****	*****	*****	*****	*****	*****	*****
0.250	*****	-0.0737	0.0198	-0.1598	-0.1598	-0.1598	-0.1598	-0.1598	-0.1598	-0.1598
0.300	-0.1146	-0.0757	0.0107	-0.1485	-0.1485	-0.1485	-0.1485	-0.1485	-0.1485	-0.1485
0.350	*****	-0.0831	-0.0031	-0.1406	-0.1406	-0.1406	-0.1406	-0.1406	-0.1406	-0.1406
0.400	-0.1425	-0.0847	-0.0149	-0.1313	-0.1313	-0.1313	-0.1313	-0.1313	-0.1313	-0.1313
0.450	-0.1566	-0.0930	-0.0086	-0.1284	-0.1284	-0.1284	-0.1284	-0.1284	-0.1284	-0.1284
0.500	-0.1721	-0.0988	-0.0398	-0.1258	-0.1258	-0.1258	-0.1258	-0.1258	-0.1258	-0.1258
0.525	*****	-0.1065	-0.0454	-0.1289	-0.1289	-0.1289	-0.1289	-0.1289	-0.1289	-0.1289
0.550	-0.1848	-0.1171	-0.0500	-0.1291	-0.1291	-0.1291	-0.1291	-0.1291	-0.1291	-0.1291
0.575	*****	-0.1260	-0.0480	-0.1324	-0.1324	-0.1324	-0.1324	-0.1324	-0.1324	-0.1324
0.600	-0.2040	-0.1332	-0.0679	-0.1356	-0.1356	-0.1356	-0.1356	-0.1356	-0.1356	-0.1356
0.625	*****	*****	-0.0708	-0.1361	-0.1361	-0.1361	-0.1361	-0.1361	-0.1361	-0.1361
0.650	-0.2189	-0.1471	-0.0750	-0.1398	-0.1398	-0.1398	-0.1398	-0.1398	-0.1398	-0.1398
0.675	*****	-0.1679	-0.0947	-0.1449	-0.1449	-0.1449	-0.1449	-0.1449	-0.1449	-0.1449
0.700	-0.2308	-0.1869	-0.1055	-0.1513	-0.1513	-0.1513	-0.1513	-0.1513	-0.1513	-0.1513
0.725	*****	-0.2070	*****	-0.1604	-0.1604	-0.1604	-0.1604	-0.1604	-0.1604	-0.1604
0.750	-0.2413	-0.2293	*****	-0.1714	-0.1714	-0.1714	-0.1714	-0.1714	-0.1714	-0.1714
0.775	*****	-0.2490	-0.1656	-0.1865	-0.1865	-0.1865	-0.1865	-0.1865	-0.1865	-0.1865
0.800	-0.2429	-0.2743	-0.1958	-0.2044	-0.2044	-0.2044	-0.2044	-0.2044	-0.2044	-0.2044
0.825	*****	-0.2940	-0.2330	-0.2151	-0.1989	-0.1989	-0.1989	-0.1989	-0.1989	-0.1989
0.850	-0.2452	-0.3154	-0.2729	-0.2655	-0.2655	-0.2655	-0.2655	-0.2655	-0.2655	-0.2655
0.875	*****	-0.3343	-0.3167	-0.3146	-0.3536	-0.3536	-0.3536	-0.3536	-0.3536	-0.3536
0.900	-0.2421	-0.3516	-0.3588	-0.3737	-0.5872	-0.5872	-0.5872	-0.5872	-0.5872	-0.5872
0.925	*****	-0.3679	-0.3964	-0.4295	-0.9980	-0.9980	-0.9980	-0.9980	-0.9980	-0.9980
0.950	-0.2360	-0.3735	-0.4307	-0.4769	-0.6467	-0.6467	-0.6467	-0.6467	-0.6467	-0.6467
0.975	*****	-0.3992	-0.4661	-0.5257	-0.5909	-0.5909	-0.5909	-0.5909	-0.5909	-0.5909
1.000	-0.1058	-0.3352	-0.4919	-0.6048	-0.4406	-0.4406	-0.4406	-0.4406	-0.4406	-0.4406
-0.200	$C_{p,l}$	$C_{p,l}$	$C_{p,l}$	$C_{p,l}$	$C_{p,l}$	$C_{p,l}$	$C_{p,l}$	$C_{p,l}$	$C_{p,l}$	$C_{p,l}$
-0.400	0.0868	0.0946	0.1441	*****	-0.4374	-0.4374	-0.4374	-0.4374	-0.4374	-0.4374
-0.600	0.0722	0.0995	0.1136	-0.0326	-0.5210	-0.5210	-0.5210	-0.5210	-0.5210	-0.5210
-0.700	0.0775	0.0955	0.1018	-0.0085	-0.6296	-0.6296	-0.6296	-0.6296	-0.6296	-0.6296
-0.800	0.0950	0.0828	0.0921	0.0074	-0.6920	-0.6920	-0.6920	-0.6920	-0.6920	-0.6920
-0.850	0.1277	*****	0.0870	0.0210	-0.6606	-0.6606	-0.6606	-0.6606	-0.6606	-0.6606
-0.900	*****	0.1136	0.0910	0.0225	-0.6835	-0.6835	-0.6835	-0.6835	-0.6835	-0.6835
-0.950	*****	0.1471	0.1142	0.0397	-0.6959	-0.6959	-0.6959	-0.6959	-0.6959	-0.6959
-0.975	0.2204	0.1925	0.1677	0.0988	-0.2785	-0.2785	-0.2785	-0.2785	-0.2785	-0.2785
-1.000	*****	0.2171	0.1970	0.1450	-0.0815	-0.0815	-0.0815	-0.0815	-0.0815	-0.0815
-1.000	-0.1113	-0.3235	-0.5739	-0.5370	-0.3573	-0.3573	-0.3573	-0.3573	-0.3573	-0.3573

Medium Radius L.E.
 Run No. = 24 , Point No. = 487
 $C_N = 0.185$, $C_m = -0.0289$
 $\alpha = 4.9^\circ$, $M_\infty = 0.799$
 $R_{mac} = 59.5 \times 10^6$

Leading Edge Pressures

● starboard
 ○ port

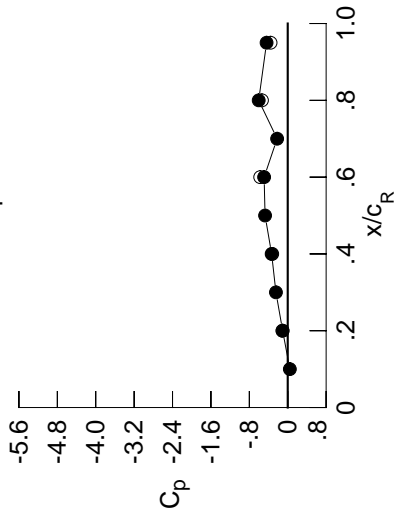

x/c_R	starb'd C_p	port C_p
0.10	0.0443	*****
0.20	-0.1058	-0.1113
0.30	-0.2458	*****
0.40	-0.3352	-0.3235
0.50	-0.4722	*****
0.60	-0.4919	-0.5739
0.70	-0.2211	*****
0.80	-0.6048	-0.5370
0.90	*****	*****
0.95	-0.4406	-0.3573

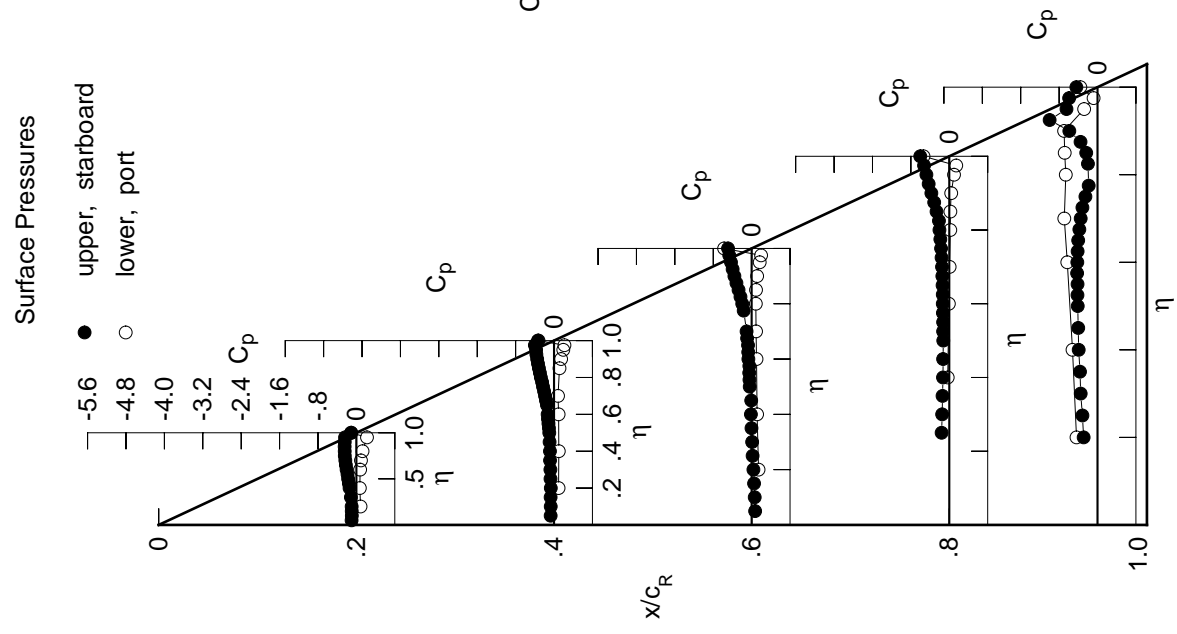
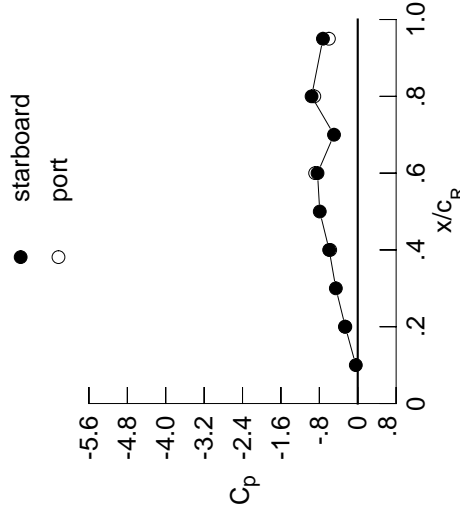

Table G1. Continued.

η	$x/c_R = .2$		$x/c_R = .4$		$x/c_R = .6$		$x/c_R = .8$		$x/c_R = .95$	
	$C_{p,u}$	$C_{p,u}$	$C_{p,u}$	$C_{p,u}$	$C_{p,u}$	$C_{p,u}$	$C_{p,u}$	$C_{p,u}$	$C_{p,u}$	$C_{p,u}$
0.050	-0.1158	-0.0835	0.0640	*****	*****	*****	*****	*****	*****	*****
0.100	-0.1126	-0.0834	0.0549	*****	*****	*****	*****	*****	*****	*****
0.150	-0.1144	-0.0863	0.0416	*****	*****	*****	*****	*****	*****	*****
0.200	-0.1169	-0.0818	0.0270	*****	*****	*****	*****	*****	*****	-0.2848
0.250	*****	-0.0885	0.0094	-0.1670	-0.1392	-0.1155	-0.0923	-0.0695	-0.0467	-0.3041
0.300	-0.1323	-0.0915	0.0010	-0.1555	-0.1337	-0.1117	-0.0890	-0.0662	-0.0434	-0.3379
0.350	*****	-0.0995	-0.0138	-0.1478	-0.1260	-0.1032	-0.0804	-0.0576	-0.0348	-0.3517
0.400	-0.1641	-0.1013	-0.0270	-0.1385	-0.1147	-0.0919	-0.0691	-0.0463	-0.0235	-0.3794
0.450	-0.1801	-0.1117	-0.0218	-0.1367	-0.1135	-0.0906	-0.0680	-0.0452	-0.0224	-0.3906
0.500	-0.1974	-0.1186	-0.0526	-0.1355	-0.1155	-0.0923	-0.0700	-0.0482	-0.0254	-0.4052
0.525	*****	-0.1277	-0.0597	-0.1389	-0.1189	-0.0957	-0.0737	-0.0517	-0.0284	-0.4105
0.550	-0.2128	-0.1393	-0.0655	-0.1392	-0.1218	-0.1000	-0.0770	-0.0547	-0.0314	-0.4107
0.575	*****	-0.1487	-0.0653	-0.1435	-0.1261	-0.1053	-0.0819	-0.0596	-0.0363	-0.4191
0.600	-0.2349	-0.1574	-0.0857	-0.1474	-0.1311	-0.1107	-0.0868	-0.0646	-0.0411	-0.4152
0.625	*****	*****	-0.0890	-0.1483	-0.1364	-0.1160	-0.0921	-0.0700	-0.0464	-0.4101
0.650	-0.2542	-0.1729	-0.0955	-0.1530	-0.1423	-0.1223	-0.1023	-0.0823	-0.0623	-0.3969
0.675	*****	-0.1961	-0.1155	-0.1597	-0.1500	-0.1280	-0.1080	-0.0880	-0.0680	-0.3722
0.700	-0.2697	-0.2169	-0.1288	-0.1668	-0.1571	-0.1351	-0.1151	-0.0951	-0.0751	-0.3411
0.725	*****	-0.2409	*****	-0.1789	-0.1668	-0.1458	-0.1258	-0.1058	-0.0858	-0.3008
0.750	-0.2854	-0.2665	*****	-0.1923	-0.1768	-0.1568	-0.1368	-0.1168	-0.0968	-0.2323
0.775	*****	-0.2922	-0.1962	-0.2118	-0.1818	-0.1618	-0.1418	-0.1218	-0.1018	-0.1606
0.800	-0.2935	-0.3218	-0.2318	-0.2329	-0.2129	-0.1929	-0.1729	-0.1529	-0.1329	*****
0.825	*****	-0.3479	-0.2738	-0.2461	-0.2261	-0.2061	-0.1861	-0.1661	-0.1461	-0.1689
0.850	-0.3034	-0.3757	-0.3213	-0.3019	-0.2819	-0.2619	-0.2419	-0.2219	-0.2019	-0.2068
0.875	*****	-0.4032	-0.3759	-0.3576	-0.3376	-0.3176	-0.2976	-0.2776	-0.2576	-0.3019
0.900	-0.3104	-0.4309	-0.4308	-0.4298	-0.4298	-0.4298	-0.4298	-0.4298	-0.4298	-0.5431
0.925	*****	-0.4602	-0.4844	-0.5037	-0.5037	-0.5037	-0.5037	-0.5037	-0.5037	-0.9015
0.950	-0.3226	-0.4823	-0.5435	-0.5764	-0.5764	-0.5764	-0.5764	-0.5764	-0.5764	-0.7010
0.975	*****	-0.5424	-0.6220	-0.6671	-0.6671	-0.6671	-0.6671	-0.6671	-0.6671	-0.6937
1.000	-0.2587	-0.5949	-0.8376	-0.9614	-0.9614	-0.9614	-0.9614	-0.9614	-0.9614	-0.7249
	$C_{p,l}$	$C_{p,l}$	$C_{p,l}$	$C_{p,l}$	$C_{p,l}$	$C_{p,l}$	$C_{p,l}$	$C_{p,l}$	$C_{p,l}$	$C_{p,l}$
-0.200	0.1107	0.1172	0.1610	*****	*****	*****	*****	*****	*****	-0.4350
-0.400	0.0987	0.1225	0.1325	-0.0168	-0.5377	-0.5377	-0.5377	-0.5377	-0.5377	-0.5377
-0.600	0.1079	0.1207	0.1231	0.0107	-0.6509	-0.6509	-0.6509	-0.6509	-0.6509	-0.6509
-0.700	0.1272	0.1117	0.1162	0.0260	-0.6898	-0.6898	-0.6898	-0.6898	-0.6898	-0.6898
-0.800	0.1600	*****	0.1143	0.0440	-0.6427	-0.6427	-0.6427	-0.6427	-0.6427	-0.6427
-0.850	*****	0.1472	0.1213	0.0480	-0.6604	-0.6604	-0.6604	-0.6604	-0.6604	-0.6604
-0.900	*****	0.1789	0.1462	0.0695	-0.6615	-0.6615	-0.6615	-0.6615	-0.6615	-0.6615
-0.950	0.2368	0.2138	0.1918	0.1258	-0.2571	-0.2571	-0.2571	-0.2571	-0.2571	-0.2571
-0.975	*****	0.2185	0.2030	0.1571	-0.0653	-0.0653	-0.0653	-0.0653	-0.0653	-0.0653
-1.000	-0.2669	-0.5733	-0.8869	-0.9044	-0.9044	-0.9044	-0.9044	-0.9044	-0.9044	-0.9044

Medium Radius L.E.
 Run No. = 24 , Point No. = 488
 $C_N = 0.227$, $C_m = -0.0350$
 $\alpha = 6.0^\circ$, $M_\infty = 0.799$
 $R_{mac} = 59.5 \times 10^6$

Leading Edge Pressures



x/c_R	starb'd C_p	port C_p
0.10	-0.0397	*****
0.20	-0.2587	-0.2669
0.30	-0.4556	*****
0.40	-0.5949	-0.5733
0.50	-0.7915	*****
0.60	-0.8376	-0.8869
0.70	-0.4943	*****
0.80	-0.9614	-0.9044
0.90	*****	*****
0.95	-0.7249	-0.6010

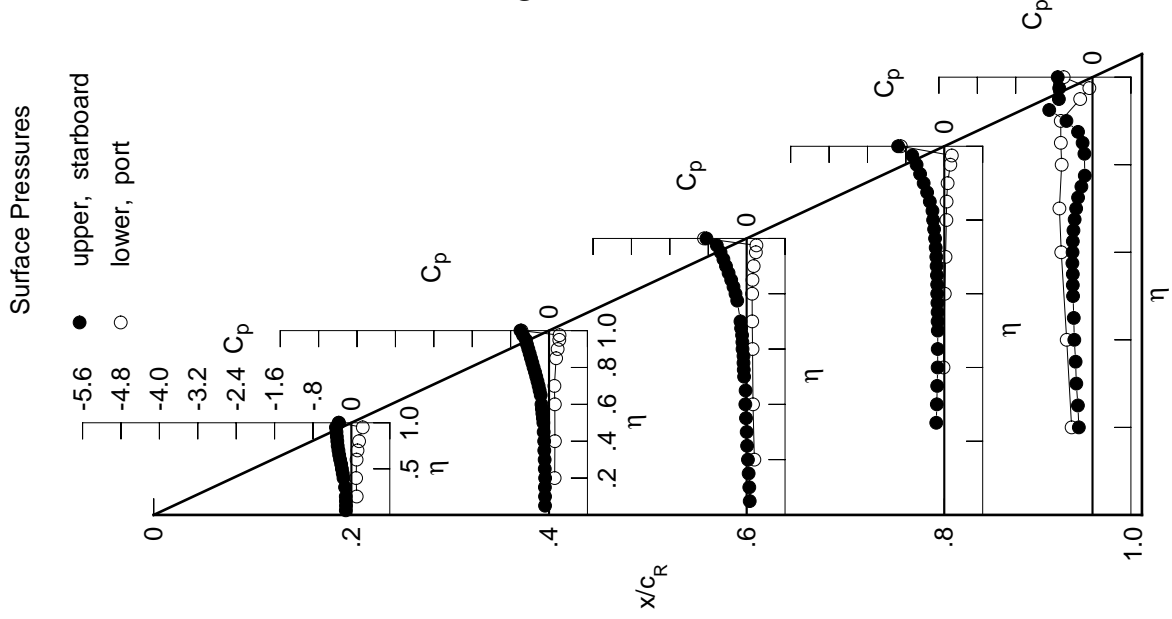
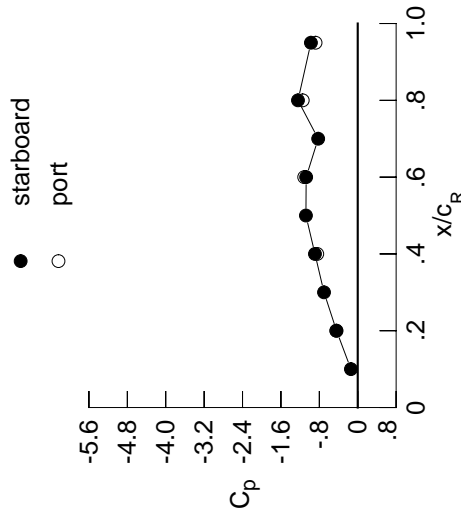

Table G1. Continued.

η	$x/c_R = .2$		$x/c_R = .4$		$x/c_R = .6$		$x/c_R = .8$		$x/c_R = .95$	
	$C_{p,u}$	$C_{p,u}$	$C_{p,u}$	$C_{p,u}$	$C_{p,u}$	$C_{p,u}$	$C_{p,u}$	$C_{p,u}$	$C_{p,u}$	$C_{p,u}$
0.050	-0.1329	-0.0995	0.0528	0.0528	0.0528	0.0528	0.0528	0.0528	0.0528	0.0528
0.100	-0.1312	-0.0997	0.0437	0.0437	0.0437	0.0437	0.0437	0.0437	0.0437	0.0437
0.150	-0.1327	-0.1023	0.0302	0.0302	0.0302	0.0302	0.0302	0.0302	0.0302	0.0302
0.200	-0.1357	-0.0995	0.0155	0.0155	0.0155	0.0155	0.0155	0.0155	0.0155	0.0155
0.250	*****	-0.1059	-0.0025	-0.1748	-0.1748	-0.1748	-0.1748	-0.1748	-0.1748	-0.1748
0.300	-0.1535	-0.1086	-0.0115	-0.1635	-0.1635	-0.1635	-0.1635	-0.1635	-0.1635	-0.1635
0.350	*****	-0.1180	-0.0275	-0.1568	-0.1568	-0.1568	-0.1568	-0.1568	-0.1568	-0.1568
0.400	-0.1868	-0.1211	-0.0417	-0.1473	-0.1473	-0.1473	-0.1473	-0.1473	-0.1473	-0.1473
0.450	-0.2048	-0.1320	-0.0373	-0.1468	-0.1468	-0.1468	-0.1468	-0.1468	-0.1468	-0.1468
0.500	-0.2239	-0.1404	-0.0689	-0.1446	-0.1446	-0.1446	-0.1446	-0.1446	-0.1446	-0.1446
0.525	*****	-0.1515	-0.0771	-0.1484	-0.1484	-0.1484	-0.1484	-0.1484	-0.1484	-0.1484
0.550	-0.2421	-0.1628	-0.0833	-0.1491	-0.1491	-0.1491	-0.1491	-0.1491	-0.1491	-0.1491
0.575	-0.1742	-0.0835	-0.1543	-0.4557	-0.4557	-0.4557	-0.4557	-0.4557	-0.4557	-0.4557
0.600	-0.2679	-0.1839	-0.1049	-0.1574	-0.1574	-0.1574	-0.1574	-0.1574	-0.1574	-0.1574
0.625	*****	*****	-0.1098	-0.1601	-0.1601	-0.1601	-0.1601	-0.1601	-0.1601	-0.1601
0.650	-0.2907	-0.2029	-0.1180	-0.1689	-0.1689	-0.1689	-0.1689	-0.1689	-0.1689	-0.1689
0.675	*****	-0.2272	-0.1407	-0.1809	-0.1809	-0.1809	-0.1809	-0.1809	-0.1809	-0.1809
0.700	-0.3114	-0.2506	-0.1575	-0.1960	-0.1960	-0.1960	-0.1960	-0.1960	-0.1960	-0.1960
0.725	*****	-0.2773	*****	-0.2157	-0.3249	-0.3249	-0.3249	-0.3249	-0.3249	-0.3249
0.750	-0.3331	-0.3065	*****	-0.2371	-0.2486	-0.2486	-0.2486	-0.2486	-0.2486	-0.2486
0.775	*****	-0.3369	-0.2359	-0.2592	-0.1729	-0.1729	-0.1729	-0.1729	-0.1729	-0.1729
0.800	-0.3476	-0.3709	-0.2727	-0.2771	*****	*****	*****	*****	*****	*****
0.825	*****	-0.4048	-0.3165	-0.2910	-0.1559	-0.1559	-0.1559	-0.1559	-0.1559	-0.1559
0.850	-0.3661	-0.4382	-0.3670	-0.3335	-0.1753	-0.1753	-0.1753	-0.1753	-0.1753	-0.1753
0.875	*****	-0.4760	-0.4303	-0.3869	-0.2103	-0.2103	-0.2103	-0.2103	-0.2103	-0.2103
0.900	-0.3851	-0.5145	-0.4983	-0.4674	-0.3215	-0.3215	-0.3215	-0.3215	-0.3215	-0.3215
0.925	*****	-0.5569	-0.5708	-0.5578	-0.4922	-0.4922	-0.4922	-0.4922	-0.4922	-0.4922
0.950	-0.4187	-0.5972	-0.6488	-0.6541	-0.6876	-0.6876	-0.6876	-0.6876	-0.6876	-0.6876
0.975	*****	-0.6977	-0.7514	-0.7723	-0.7463	-0.7463	-0.7463	-0.7463	-0.7463	-0.7463
1.000	-0.4417	-0.8908	-1.0743	-1.2447	-0.9753	-0.9753	-0.9753	-0.9753	-0.9753	-0.9753
-0.200	$C_{p,l}$	$C_{p,l}$	$C_{p,l}$	$C_{p,l}$	$C_{p,l}$	$C_{p,l}$	$C_{p,l}$	$C_{p,l}$	$C_{p,l}$	$C_{p,l}$
-0.400	0.1334	0.1352	0.1754	0.1754	0.1754	0.1754	0.1754	0.1754	0.1754	0.1754
-0.600	0.1218	0.1414	0.1472	0.0044	-0.5428	-0.5428	-0.5428	-0.5428	-0.5428	-0.5428
-0.700	0.1340	0.1416	0.1394	0.0238	-0.6167	-0.6167	-0.6167	-0.6167	-0.6167	-0.6167
-0.800	0.1540	0.1345	0.1347	0.0417	-0.6568	-0.6568	-0.6568	-0.6568	-0.6568	-0.6568
-0.850	0.1868	*****	0.1356	0.0617	-0.6165	-0.6165	-0.6165	-0.6165	-0.6165	-0.6165
-0.900	*****	0.1736	0.1446	0.0682	-0.6327	-0.6327	-0.6327	-0.6327	-0.6327	-0.6327
-0.950	*****	0.2025	0.1694	0.0924	-0.6277	-0.6277	-0.6277	-0.6277	-0.6277	-0.6277
-0.975	0.2432	0.2255	0.2048	0.1431	-0.2422	-0.2422	-0.2422	-0.2422	-0.2422	-0.2422
-1.000	*****	0.2084	0.1976	0.1577	-0.0602	-0.0602	-0.0602	-0.0602	-0.0602	-0.0602
-1.000	-0.4478	-0.8431	-1.1150	-1.1455	-0.8787	-0.8787	-0.8787	-0.8787	-0.8787	-0.8787

Medium Radius L.E.
 Run No. = 24 , Point No. = 489
 $C_N = 0.267$, $C_m = -0.0409$
 $\alpha = 7.0^\circ$, $M_\infty = 0.797$
 $R_{mac} = 59.5 \times 10^6$

Leading Edge Pressures



x/c_R	starb'd C_p	port C_p
0.10	-0.1417	*****
0.20	-0.4417	-0.4478
0.30	-0.7026	*****
0.40	-0.8908	-0.8431
0.50	-1.0793	*****
0.60	-1.0743	-1.1150
0.70	-0.8241	*****
0.80	-1.2447	-1.1455
0.90	*****	*****
0.95	-0.9753	-0.8787

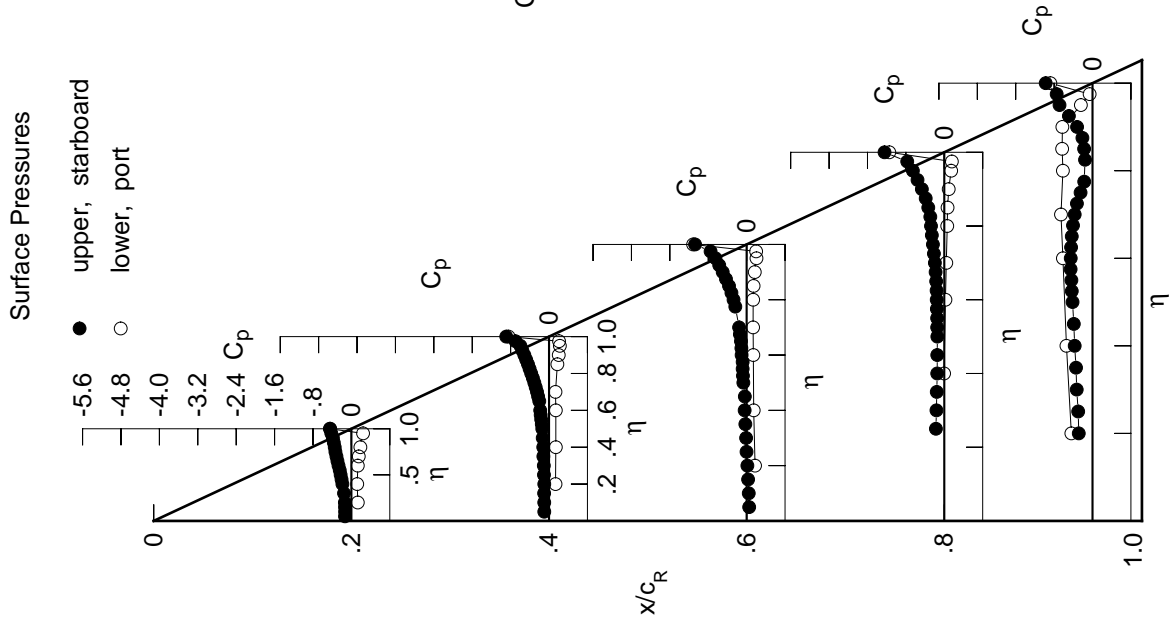
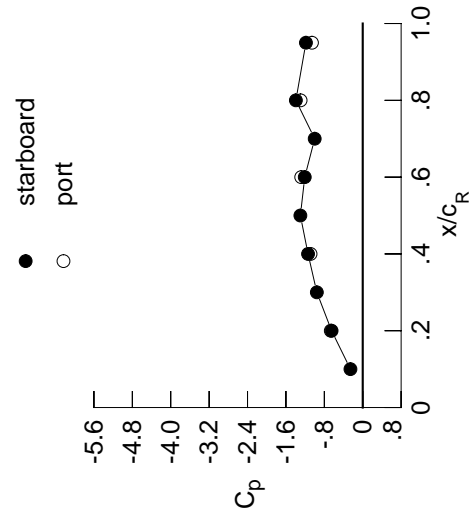

Table G1. Continued.

η	$x/c_R = .2$		$x/c_R = .4$		$x/c_R = .6$		$x/c_R = .8$		$x/c_R = .95$	
	$C_{p,u}$	$C_{p,u}$	$C_{p,u}$	$C_{p,u}$	$C_{p,u}$	$C_{p,u}$	$C_{p,u}$	$C_{p,u}$	$C_{p,u}$	$C_{p,u}$
0.050	-0.1482	-0.1148	0.0410	0.0410	0.0410	0.0410	0.0410	0.0410	0.0410	0.0410
0.100	-0.1489	-0.1153	0.0312	0.0312	0.0312	0.0312	0.0312	0.0312	0.0312	0.0312
0.150	-0.1512	-0.1195	0.0177	0.0177	0.0177	0.0177	0.0177	0.0177	0.0177	0.0177
0.200	-0.1545	-0.1152	0.0023	0.0023	0.0023	0.0023	0.0023	0.0023	0.0023	0.0023
0.250	0.0000	-0.1225	-0.0156	-0.0156	-0.0156	-0.0156	-0.0156	-0.0156	-0.0156	-0.0156
0.300	-0.1739	-0.1269	-0.0255	-0.0255	-0.0255	-0.0255	-0.0255	-0.0255	-0.0255	-0.0255
0.350	0.0000	-0.1366	-0.0418	-0.0418	-0.0418	-0.0418	-0.0418	-0.0418	-0.0418	-0.0418
0.400	-0.2099	-0.1397	-0.0561	-0.0561	-0.0561	-0.0561	-0.0561	-0.0561	-0.0561	-0.0561
0.450	-0.2289	-0.1538	-0.0532	-0.0532	-0.0532	-0.0532	-0.0532	-0.0532	-0.0532	-0.0532
0.500	-0.2503	-0.1626	-0.0855	-0.0855	-0.0855	-0.0855	-0.0855	-0.0855	-0.0855	-0.0855
0.525	0.0000	-0.1751	-0.0939	-0.0939	-0.0939	-0.0939	-0.0939	-0.0939	-0.0939	-0.0939
0.550	-0.2713	-0.1883	-0.1021	-0.1021	-0.1021	-0.1021	-0.1021	-0.1021	-0.1021	-0.1021
0.575	0.0000	-0.2000	-0.1043	-0.1043	-0.1043	-0.1043	-0.1043	-0.1043	-0.1043	-0.1043
0.600	-0.3004	-0.2131	-0.1339	-0.1339	-0.1339	-0.1339	-0.1339	-0.1339	-0.1339	-0.1339
0.625	0.0000	0.0000	-0.1463	-0.1463	-0.1463	-0.1463	-0.1463	-0.1463	-0.1463	-0.1463
0.650	-0.3280	-0.2379	-0.1619	-0.1619	-0.1619	-0.1619	-0.1619	-0.1619	-0.1619	-0.1619
0.675	0.0000	-0.2626	-0.1889	-0.1889	-0.1889	-0.1889	-0.1889	-0.1889	-0.1889	-0.1889
0.700	-0.3533	-0.2864	-0.2096	-0.2096	-0.2096	-0.2096	-0.2096	-0.2096	-0.2096	-0.2096
0.725	0.0000	-0.3154	0.0000	0.0000	0.0000	0.0000	0.0000	0.0000	0.0000	0.0000
0.750	-0.3814	-0.3474	0.0000	0.0000	0.0000	0.0000	0.0000	0.0000	0.0000	0.0000
0.775	0.0000	-0.3820	-0.2776	-0.2776	-0.2776	-0.2776	-0.2776	-0.2776	-0.2776	-0.2776
0.800	-0.4033	-0.4207	-0.3093	-0.3093	-0.3093	-0.3093	-0.3093	-0.3093	-0.3093	-0.3093
0.825	0.0000	-0.4614	-0.3517	-0.3517	-0.3517	-0.3517	-0.3517	-0.3517	-0.3517	-0.3517
0.850	-0.4321	-0.5026	-0.4038	-0.4038	-0.4038	-0.4038	-0.4038	-0.4038	-0.4038	-0.4038
0.875	0.0000	-0.5499	-0.4694	-0.4694	-0.4694	-0.4694	-0.4694	-0.4694	-0.4694	-0.4694
0.900	-0.4638	-0.5975	-0.5486	-0.5486	-0.5486	-0.5486	-0.5486	-0.5486	-0.5486	-0.5486
0.925	0.0000	-0.6539	-0.6403	-0.6403	-0.6403	-0.6403	-0.6403	-0.6403	-0.6403	-0.6403
0.950	-0.5224	-0.7105	-0.7554	-0.7554	-0.7554	-0.7554	-0.7554	-0.7554	-0.7554	-0.7554
0.975	0.0000	-0.8231	-1.0803	-1.0803	-1.0803	-1.0803	-1.0803	-1.0803	-1.0803	-1.0803
1.000	-0.6490	-1.1392	-1.2079	-1.2079	-1.2079	-1.2079	-1.2079	-1.2079	-1.2079	-1.2079
-0.200	$C_{p,l}$	0.1574	0.1558	0.1940	0.1940	0.1940	0.1940	0.1940	0.1940	0.1940
-0.400	$C_{p,l}$	0.1472	0.1636	0.1666	0.1666	0.1666	0.1666	0.1666	0.1666	0.1666
-0.600	$C_{p,l}$	0.1616	0.1650	0.1594	0.1594	0.1594	0.1594	0.1594	0.1594	0.1594
-0.700	$C_{p,l}$	0.1825	0.1607	0.1561	0.1561	0.1561	0.1561	0.1561	0.1561	0.1561
-0.800	$C_{p,l}$	0.2142	0.1599	0.1599	0.1599	0.1599	0.1599	0.1599	0.1599	0.1599
-0.850	$C_{p,l}$	0.2005	0.1703	0.1703	0.1703	0.1703	0.1703	0.1703	0.1703	0.1703
-0.900	$C_{p,l}$	0.2257	0.1932	0.1932	0.1932	0.1932	0.1932	0.1932	0.1932	0.1932
-0.950	$C_{p,l}$	0.2465	0.2344	0.2168	0.2168	0.2168	0.2168	0.2168	0.2168	0.2168
-0.975	$C_{p,l}$	0.1939	0.1896	0.1896	0.1896	0.1896	0.1896	0.1896	0.1896	0.1896
-1.000	$C_{p,l}$	-0.6655	-1.0872	-1.2816	-1.2816	-1.2816	-1.2816	-1.2816	-1.2816	-1.2816

Medium Radius L.E.
 Run No. = 24 , Point No. = 490
 $C_N = 0.321$, $C_m = -0.0526$
 $\alpha = 8.1^\circ$, $M_\infty = 0.800$
 $R_{mac} = 59.5 \times 10^6$

Leading Edge Pressures



x/c_R	starb'd C_p	port C_p
0.10	-0.2558	0.0000
0.20	-0.6490	-0.6655
0.30	-0.9559	0.0000
0.40	-1.1392	-1.0872
0.50	-1.2989	0.0000
0.60	-1.2079	-1.2816
0.70	-1.0007	0.0000
0.80	-1.3929	-1.2946
0.90	0.0000	0.0000
0.95	-1.1834	-1.0577

Surface Pressures

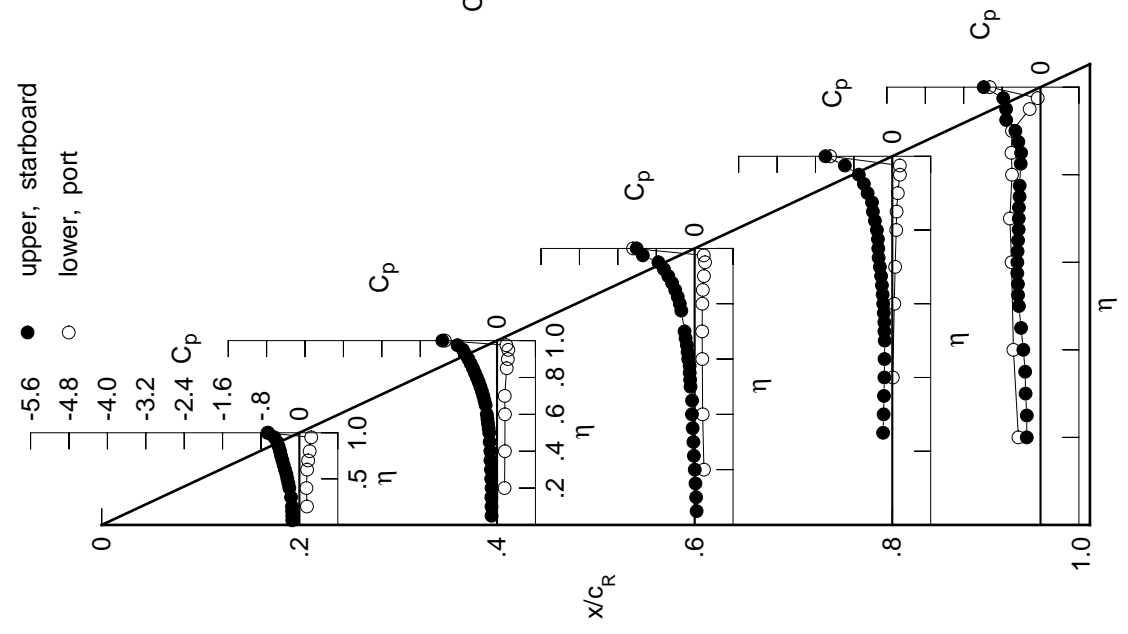

Table G1. Continued.

η	x/c_R .2	x/c_R .4	x/c_R .6	x/c_R .8	x/c_R .95
	$C_{p,u}$	$C_{p,u}$	$C_{p,u}$	$C_{p,u}$	$C_{p,u}$
0.050	-0.1632	-0.1310	0.0263	*****	*****
0.100	-0.1663	-0.1331	0.0178	*****	*****
0.150	-0.1695	-0.1365	0.0022	*****	*****
0.200	-0.1740	-0.1334	-0.0131	*****	-0.3091
0.250	*****	-0.1413	-0.0324	-0.2068	-0.2895
0.300	-0.1951	-0.1466	-0.0414	-0.1966	-0.3029
0.350	*****	-0.1570	-0.0576	-0.1861	-0.3486
0.400	-0.2325	-0.1614	-0.0700	-0.1742	-0.4216
0.450	-0.2531	-0.1749	-0.0635	-0.1742	-0.4606
0.500	-0.2767	-0.1898	-0.1103	-0.1810	-0.4782
0.525	*****	-0.2044	-0.1278	-0.1922	-0.4814
0.550	-0.3008	-0.2225	-0.1447	-0.2034	-0.4716
0.575	*****	-0.2385	-0.1552	-0.2235	-0.4735
0.600	-0.3333	-0.2536	-0.1878	-0.2408	-0.4604
0.625	*****	*****	-0.1995	-0.2515	-0.4466
0.650	-0.3650	-0.2814	-0.2176	-0.2661	-0.4346
0.675	*****	-0.3041	-0.2406	-0.2906	-0.4360
0.700	-0.3963	-0.3266	-0.2425	-0.3146	-0.4545
0.725	*****	-0.3518	*****	-0.3306	-0.4634
0.750	-0.4307	-0.3831	*****	-0.3337	-0.4419
0.775	*****	-0.4186	-0.3469	-0.3553	-0.4435
0.800	-0.4614	-0.4623	-0.3689	-0.4214	*****
0.825	*****	-0.5074	-0.3972	-0.5073	-0.4562
0.850	-0.5001	-0.5547	-0.4628	-0.4978	-0.4294
0.875	*****	-0.6091	-0.5168	-0.4534	-0.4502
0.900	-0.5461	-0.6696	-0.5623	-0.4569	-0.5230
0.925	*****	-0.7326	-0.8482	-0.7856	-0.6592
0.950	-0.6337	-0.7970	-0.8053	-0.9362	-0.5704
0.975	*****	-1.1642	-1.4031	-0.8449	-0.8601
1.000	-0.8565	-1.3055	-1.3023	-1.4675	-1.2419
	$C_{p,l}$	$C_{p,l}$	$C_{p,l}$	$C_{p,l}$	$C_{p,l}$
-0.200	0.1812	0.1781	0.2092	*****	-0.4559
-0.400	0.1730	0.1848	0.1842	0.0274	-0.5623
-0.600	0.1893	0.1891	0.1784	0.0556	-0.6203
-0.700	0.2097	0.1861	0.1760	0.0763	-0.6437
-0.800	0.2389	*****	0.1812	0.0993	-0.5839
-0.850	*****	0.2258	0.1920	0.1088	-0.5895
-0.900	*****	0.2456	0.2127	0.1343	-0.5698
-0.950	0.2450	0.2388	0.2237	0.1695	-0.2118
-0.975	*****	0.1767	0.1788	0.1537	-0.0549
-1.000	-0.9002	-1.2476	-1.3798	-1.3535	-1.0930

Medium Radius L.E.
 Run No. = 24, Point No. = 491
 $C_N = 0.369$, $C_m = -0.0604$
 $\alpha = 9.1^\circ$, $M_\infty = 0.801$
 $R_{mac} = 59.5 \times 10^6$

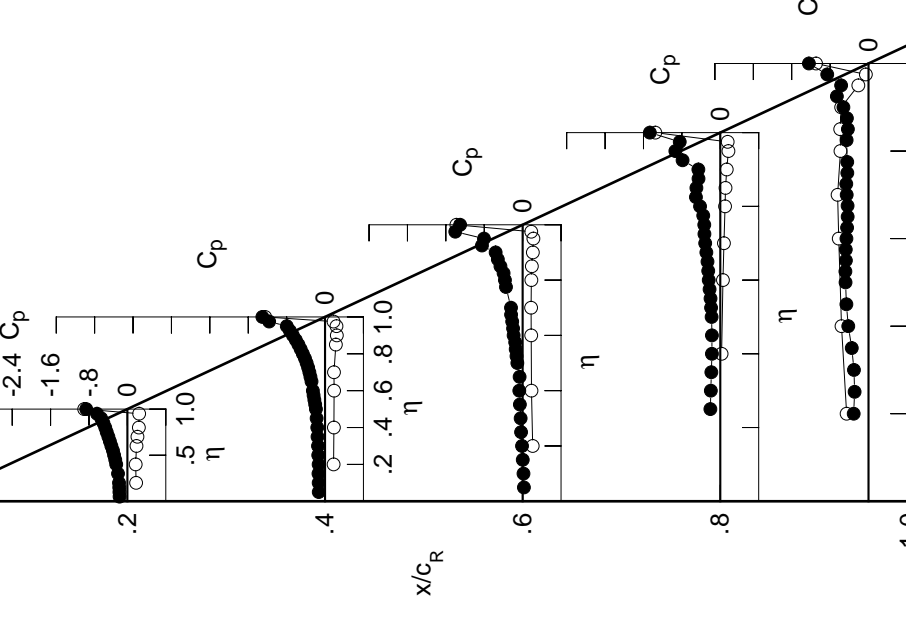
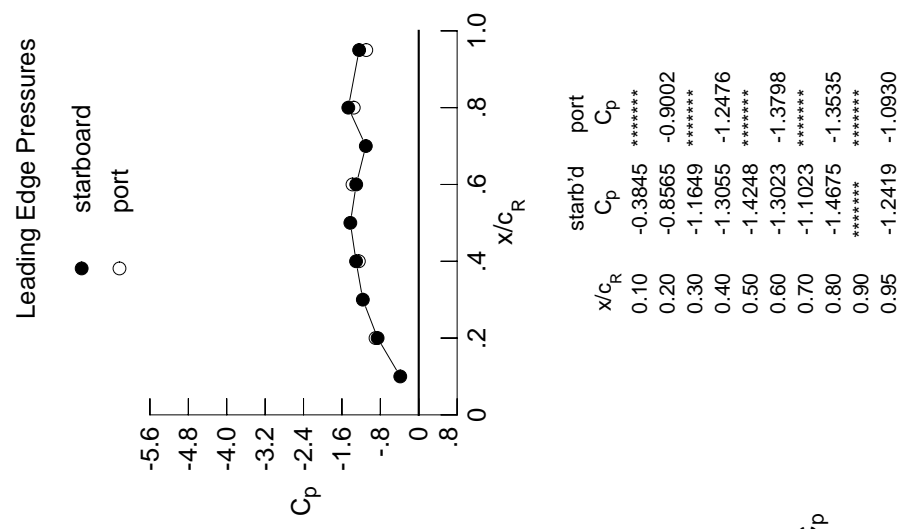
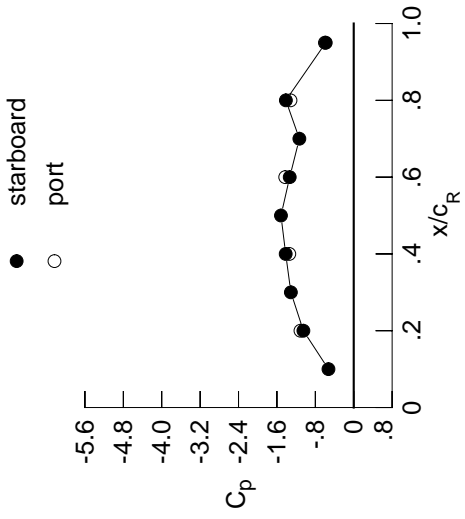

Table G1. Continued.

η	$x/c_R = .2$		$x/c_R = .4$		$x/c_R = .6$		$x/c_R = .8$		$x/c_R = .95$	
	$C_{p,u}$	$C_{p,l}$	$C_{p,u}$	$C_{p,l}$	$C_{p,u}$	$C_{p,l}$	$C_{p,u}$	$C_{p,l}$	$C_{p,u}$	$C_{p,l}$
0.050	-0.1759	-0.1507	0.0078	0.0078	0.0078	0.0078	0.0078	0.0078	0.0078	0.0078
0.100	-0.1820	-0.1537	-0.0030	-0.0030	-0.0030	-0.0030	-0.0030	-0.0030	-0.0030	-0.0030
0.150	-0.1875	-0.1581	-0.0189	-0.0189	-0.0189	-0.0189	-0.0189	-0.0189	-0.0189	-0.0189
0.200	-0.1929	-0.1548	-0.0344	-0.0344	-0.0344	-0.0344	-0.0344	-0.0344	-0.0344	-0.0344
0.250	0.0000	-0.1647	-0.0543	-0.2246	-0.2246	-0.2246	-0.2246	-0.2246	-0.2246	-0.2246
0.300	-0.2157	-0.1689	-0.0595	-0.2101	-0.3084	-0.3084	-0.3084	-0.3084	-0.3084	-0.3084
0.350	0.0000	-0.1789	-0.0759	-0.2006	-0.3742	-0.3742	-0.3742	-0.3742	-0.3742	-0.3742
0.400	-0.2547	-0.1823	-0.0932	-0.1899	-0.4438	-0.4438	-0.4438	-0.4438	-0.4438	-0.4438
0.450	-0.2766	-0.2051	-0.0993	-0.2078	-0.4617	-0.4617	-0.4617	-0.4617	-0.4617	-0.4617
0.500	-0.3028	-0.2332	-0.1606	-0.2237	-0.4553	-0.4553	-0.4553	-0.4553	-0.4553	-0.4553
0.525	0.0000	-0.2527	-0.1845	-0.2366	-0.4463	-0.4463	-0.4463	-0.4463	-0.4463	-0.4463
0.550	-0.3295	-0.2708	-0.2011	-0.2452	-0.4297	-0.4297	-0.4297	-0.4297	-0.4297	-0.4297
0.575	0.0000	-0.2859	-0.2084	-0.2574	-0.4234	-0.4234	-0.4234	-0.4234	-0.4234	-0.4234
0.600	-0.3656	-0.2981	-0.2370	-0.2664	-0.4158	-0.4158	-0.4158	-0.4158	-0.4158	-0.4158
0.625	0.0000	0.0000	-0.2393	-0.2687	-0.4261	-0.4261	-0.4261	-0.4261	-0.4261	-0.4261
0.650	-0.4029	-0.3221	-0.2482	-0.2760	-0.4555	-0.4555	-0.4555	-0.4555	-0.4555	-0.4555
0.675	0.0000	-0.3454	-0.2812	-0.2978	-0.5019	-0.5019	-0.5019	-0.5019	-0.5019	-0.5019
0.700	-0.4392	-0.3664	-0.3065	-0.3459	-0.5544	-0.5544	-0.5544	-0.5544	-0.5544	-0.5544
0.725	0.0000	-0.3896	0.0000	-0.4393	-0.5982	-0.5982	-0.5982	-0.5982	-0.5982	-0.5982
0.750	-0.4813	-0.4147	0.0000	-0.5284	-0.6233	-0.6233	-0.6233	-0.6233	-0.6233	-0.6233
0.775	0.0000	-0.4435	-0.4036	-0.5901	-0.6565	-0.6565	-0.6565	-0.6565	-0.6565	-0.6565
0.800	-0.5206	-0.4833	-0.4494	-0.6279	0.0000	0.0000	0.0000	0.0000	0.0000	0.0000
0.825	0.0000	-0.5266	-0.4616	-0.6680	-0.6190	-0.6190	-0.6190	-0.6190	-0.6190	-0.6190
0.850	-0.5729	-0.6081	-0.5085	-0.6685	-0.5729	-0.5729	-0.5729	-0.5729	-0.5729	-0.5729
0.875	0.0000	-0.7317	-0.7668	-0.6761	-0.5416	-0.5416	-0.5416	-0.5416	-0.5416	-0.5416
0.900	-0.6306	-0.7585	-0.9340	-0.7737	-0.5176	-0.5176	-0.5176	-0.5176	-0.5176	-0.5176
0.925	0.0000	-0.8169	-1.0766	-0.8688	-0.4688	-0.4688	-0.4688	-0.4688	-0.4688	-0.4688
0.950	-0.7383	-1.2478	-1.1319	-0.8275	-0.3993	-0.3993	-0.3993	-0.3993	-0.3993	-0.3993
0.975	0.0000	-1.4294	-1.1066	-0.7300	-0.3437	-0.3437	-0.3437	-0.3437	-0.3437	-0.3437
1.000	-1.0488	-1.4175	-1.3336	-1.4140	-0.5831	-0.5831	-0.5831	-0.5831	-0.5831	-0.5831
-0.200	0.2086	0.2018	0.2278	0.2375	0.2278	0.2278	0.2278	0.2278	0.2278	0.2278
-0.400	0.2009	0.2098	0.2035	0.0414	-0.5850	-0.5850	-0.5850	-0.5850	-0.5850	-0.5850
-0.600	0.2184	0.2150	0.1987	0.0729	-0.6339	-0.6339	-0.6339	-0.6339	-0.6339	-0.6339
-0.700	0.2390	0.2126	0.1982	0.0934	-0.6395	-0.6395	-0.6395	-0.6395	-0.6395	-0.6395
-0.800	0.2647	0.2000	0.2040	0.1181	-0.5736	-0.5736	-0.5736	-0.5736	-0.5736	-0.5736
-0.850	0.0000	0.2510	0.2147	0.1286	-0.5752	-0.5752	-0.5752	-0.5752	-0.5752	-0.5752
-0.900	0.0000	0.2655	0.2325	0.1535	-0.5487	-0.5487	-0.5487	-0.5487	-0.5487	-0.5487
-0.950	0.2417	0.2442	0.2315	0.1823	-0.1894	-0.1894	-0.1894	-0.1894	-0.1894	-0.1894
-0.975	0.0000	0.1616	0.1711	0.1569	-0.0260	-0.0260	-0.0260	-0.0260	-0.0260	-0.0260
-1.000	-1.1098	-1.3424	-1.4272	-1.3173	-0.5999	-0.5999	-0.5999	-0.5999	-0.5999	-0.5999

Medium Radius L.E.
 Run No. = 24 , Point No. = 492
 $C_N = 0.427$, $C_m = -0.0714$
 $\alpha = 10.2^\circ$, $M_\infty = 0.801$
 $R_{mac} = 59.6 \times 10^6$

Leading Edge Pressures



x/c_R	starb'd C_p	port C_p
0.10	-0.5265	0.0000
0.20	-1.0488	-1.1098
0.30	-1.3095	0.0000
0.40	-1.4175	-1.3424
0.50	-1.5157	0.0000
0.60	-1.3336	-1.4272
0.70	-1.1326	0.0000
0.80	-1.4140	-1.3173
0.90	0.0000	0.0000
0.95	-0.5831	-0.5999

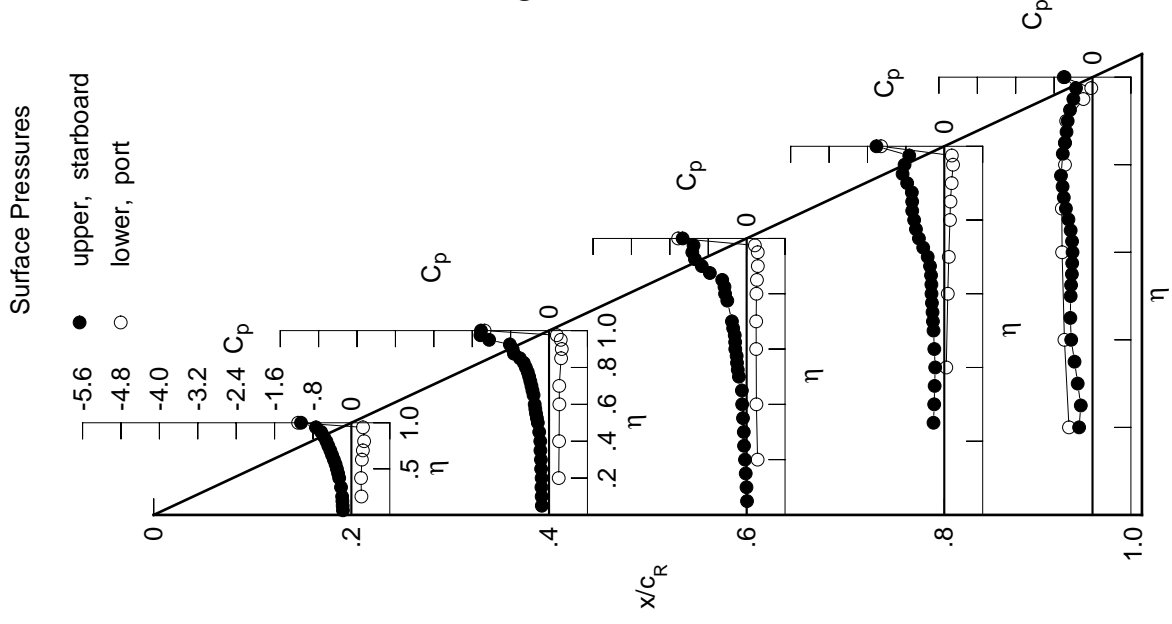
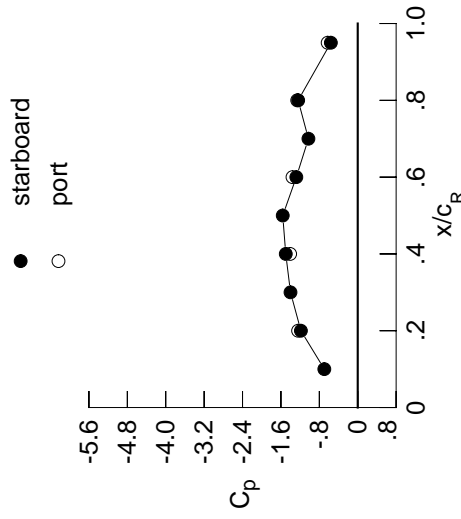

Table G1. Continued.

η	$x/c_R = .2$		$x/c_R = .4$		$x/c_R = .6$		$x/c_R = .8$		$x/c_R = .95$	
	$C_{p,u}$	$C_{p,u}$	$C_{p,u}$	$C_{p,u}$	$C_{p,u}$	$C_{p,u}$	$C_{p,u}$	$C_{p,u}$	$C_{p,u}$	$C_{p,u}$
0.050	-0.1939	-0.1802	-0.0179	*****	*****	*****	*****	*****	*****	*****
0.100	-0.1999	-0.1816	-0.0295	*****	*****	*****	*****	*****	*****	*****
0.150	-0.2098	-0.1868	-0.0467	*****	*****	*****	*****	*****	*****	*****
0.200	-0.2155	-0.1853	-0.0619	*****	*****	*****	*****	*****	*****	-0.2503
0.250	*****	-0.1937	-0.0769	-0.2409	-0.2366	*****	*****	*****	*****	-0.2366
0.300	-0.2422	-0.1955	-0.0860	-0.2255	-0.3258	*****	*****	*****	*****	-0.3258
0.350	*****	-0.2063	-0.1076	-0.2179	-0.3821	*****	*****	*****	*****	-0.3821
0.400	-0.2820	-0.2249	-0.1327	-0.2142	-0.4287	*****	*****	*****	*****	-0.4287
0.450	-0.3058	-0.2634	-0.1496	-0.2235	-0.4322	*****	*****	*****	*****	-0.4322
0.500	-0.3343	-0.2955	-0.2033	-0.2380	-0.4110	*****	*****	*****	*****	-0.4110
0.525	*****	-0.3039	-0.2211	-0.2397	-0.4046	*****	*****	*****	*****	-0.4046
0.550	-0.3650	-0.3045	-0.2416	-0.2323	-0.4002	*****	*****	*****	*****	-0.4002
0.575	*****	-0.3083	-0.2662	-0.2314	-0.4138	*****	*****	*****	*****	-0.4138
0.600	-0.4032	-0.3172	-0.3151	-0.2336	-0.4150	*****	*****	*****	*****	-0.4150
0.625	*****	*****	-0.3212	-0.2357	-0.4296	*****	*****	*****	*****	-0.4296
0.650	-0.4436	-0.3694	-0.3229	-0.2625	-0.4773	*****	*****	*****	*****	-0.4773
0.675	*****	-0.4374	-0.3372	-0.3435	-0.5853	*****	*****	*****	*****	-0.5853
0.700	-0.4862	-0.4761	-0.3564	-0.5067	-0.7619	*****	*****	*****	*****	-0.7619
0.725	*****	-0.4684	*****	-0.7441	-0.9286	*****	*****	*****	*****	-0.9286
0.750	-0.5347	-0.4691	*****	-0.9161	-1.0107	*****	*****	*****	*****	-1.0107
0.775	*****	-0.4692	-0.6860	-1.0050	-0.9878	*****	*****	*****	*****	-0.9878
0.800	-0.5806	-0.4897	-0.7692	-0.9667	*****	*****	*****	*****	*****	-0.9667
0.825	*****	-0.5664	-0.8354	-0.9370	-0.7327	*****	*****	*****	*****	-0.7327
0.850	-0.6360	-0.8247	-0.9147	-0.8802	-0.6028	*****	*****	*****	*****	-0.6028
0.875	*****	-0.9708	-1.0100	-0.8326	-0.5282	*****	*****	*****	*****	-0.5282
0.900	-0.7083	-0.8782	-1.0536	-0.7981	-0.4752	*****	*****	*****	*****	-0.4752
0.925	*****	-0.8015	-1.0298	-0.7513	-0.4528	*****	*****	*****	*****	-0.4528
0.950	-0.8263	-1.5183	-0.9780	-0.7057	-0.3937	*****	*****	*****	*****	-0.3937
0.975	*****	-1.5191	-0.9335	-0.6643	-0.3426	*****	*****	*****	*****	-0.3426
1.000	-1.1839	-1.4995	-1.2795	-1.2410	-0.5603	*****	*****	*****	*****	-0.5603
-0.200	$C_{p,l}$	$C_{p,l}$	$C_{p,l}$	$C_{p,l}$	$C_{p,l}$	$C_{p,l}$	$C_{p,l}$	$C_{p,l}$	$C_{p,l}$	$C_{p,l}$
-0.400	0.2362	0.2262	0.2474	*****	-0.5176	*****	*****	*****	*****	-0.5176
-0.600	0.2295	0.2341	0.2232	0.0584	-0.6020	*****	*****	*****	*****	-0.6020
-0.700	0.2489	0.2400	0.2188	0.0886	-0.6422	*****	*****	*****	*****	-0.6422
-0.800	0.2676	0.2384	0.2199	0.1093	-0.6314	*****	*****	*****	*****	-0.6314
-0.850	0.2895	*****	0.2264	0.1338	-0.5584	*****	*****	*****	*****	-0.5584
-0.900	*****	0.2727	0.2368	0.1440	-0.5587	*****	*****	*****	*****	-0.5587
-0.950	*****	0.2814	0.2517	0.1680	-0.5276	*****	*****	*****	*****	-0.5276
-0.975	0.2358	0.2442	0.2401	0.1882	-0.1816	*****	*****	*****	*****	-0.1816
-1.000	*****	0.1418	0.1674	0.1520	-0.0307	*****	*****	*****	*****	-0.0307
	-1.2428	-1.4080	-1.3592	-1.2611	-0.6260	*****	*****	*****	*****	-0.6260

Medium Radius L.E.
 Run No. = 24 , Point No. = 493
 $C_N = 0.494$, $C_m = -0.0837$
 $\alpha = 11.2^\circ$, $M_\infty = 0.801$
 $R_{mac} = 59.3 \times 10^6$

Leading Edge Pressures



x/c_R	starb'd C_p	port C_p
0.10	-0.6957	*****
0.20	-1.1839	-1.2428
0.30	-1.4007	*****
0.40	-1.4995	-1.4080
0.50	-1.5622	*****
0.60	-1.2795	-1.3592
0.70	-1.0273	*****
0.80	-1.2410	-1.2611
0.90	*****	*****
0.95	-0.5603	-0.6260

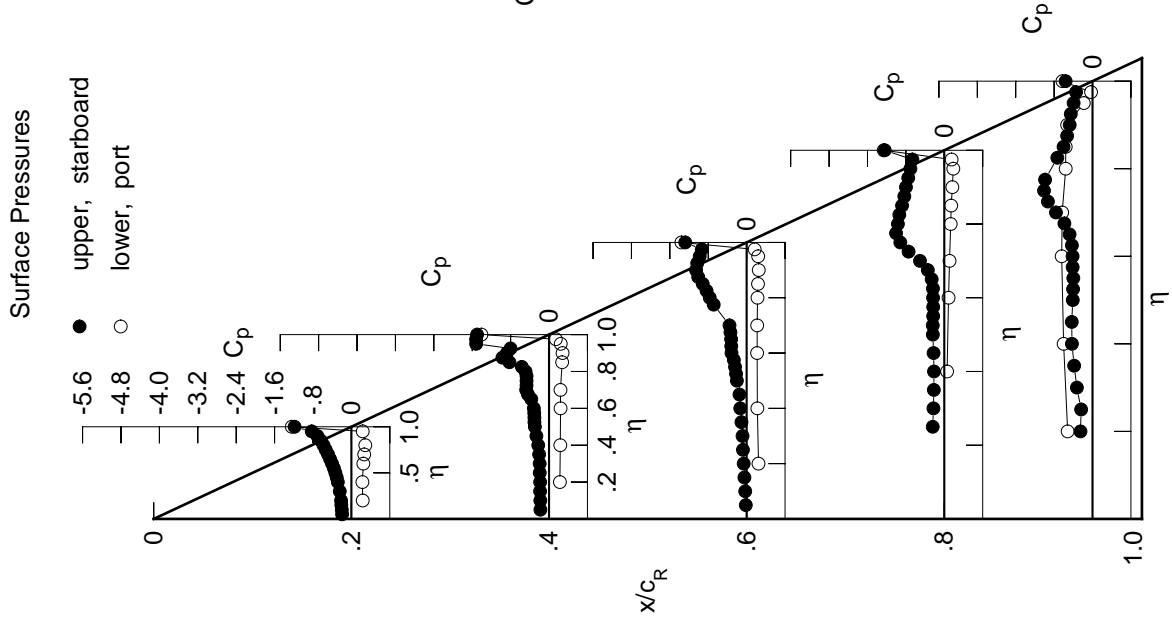
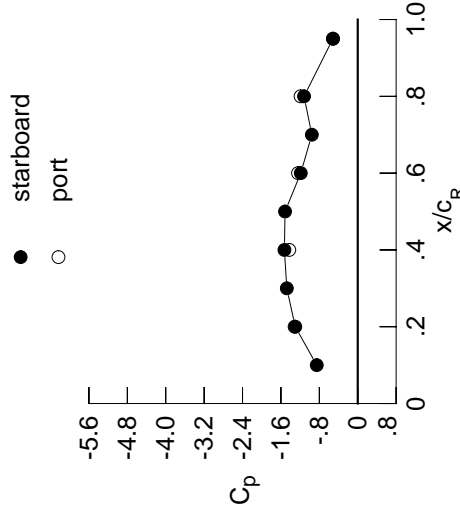

Table G1. Continued.

η	$x/c_R = .2$		$x/c_R = .4$		$x/c_R = .6$		$x/c_R = .8$		$x/c_R = .95$	
	$C_{p,u}$	$C_{p,l}$	$C_{p,u}$	$C_{p,l}$	$C_{p,u}$	$C_{p,l}$	$C_{p,u}$	$C_{p,l}$	$C_{p,u}$	$C_{p,l}$
0.050	-0.2140	-0.2152	-0.0433	*****	*****	*****	*****	*****	*****	*****
0.100	-0.2168	-0.2155	-0.0529	*****	*****	*****	*****	*****	*****	*****
0.150	-0.2322	-0.2212	-0.0716	*****	*****	*****	*****	*****	*****	*****
0.200	-0.2406	-0.2214	-0.0808	*****	*****	*****	*****	*****	*****	*****
0.250	*****	-0.2235	-0.0995	-0.2569	-0.2698	*****	*****	*****	*****	*****
0.300	-0.2713	-0.2274	-0.1113	-0.2452	-0.3483	*****	*****	*****	*****	*****
0.350	*****	-0.2500	-0.1398	-0.2404	-0.3790	*****	*****	*****	*****	*****
0.400	-0.3141	-0.2801	-0.1604	-0.2361	-0.3957	*****	*****	*****	*****	*****
0.450	-0.3419	-0.3252	-0.1764	-0.2281	-0.3993	*****	*****	*****	*****	*****
0.500	-0.3718	-0.3302	-0.2179	-0.2161	-0.4357	*****	*****	*****	*****	*****
0.525	*****	-0.3322	-0.2240	-0.2136	-0.4541	*****	*****	*****	*****	*****
0.550	-0.4016	-0.3416	-0.2303	-0.2064	-0.4544	*****	*****	*****	*****	*****
0.575	*****	-0.3600	-0.2458	-0.2121	-0.4712	*****	*****	*****	*****	*****
0.600	-0.4395	-0.3960	-0.3190	-0.2362	-0.4837	*****	*****	*****	*****	*****
0.625	*****	*****	-0.3785	-0.2971	-0.5507	*****	*****	*****	*****	*****
0.650	-0.4847	-0.4662	-0.4929	-0.4404	-0.6924	*****	*****	*****	*****	*****
0.675	*****	-0.4904	-0.6195	-0.6772	-0.8674	*****	*****	*****	*****	*****
0.700	-0.5329	-0.5031	-0.7127	-0.9206	-1.0374	*****	*****	*****	*****	*****
0.725	*****	-0.5096	*****	-1.0850	-1.1362	*****	*****	*****	*****	*****
0.750	-0.5856	-0.5270	*****	-1.1167	-1.1317	*****	*****	*****	*****	*****
0.775	*****	-0.5634	-0.9328	-1.1187	-0.9345	*****	*****	*****	*****	*****
0.800	-0.6358	-0.6873	-0.9659	-1.0452	*****	*****	*****	*****	*****	*****
0.825	*****	-0.9008	-1.0019	-1.0035	-0.6039	*****	*****	*****	*****	*****
0.850	-0.7034	-1.0004	-1.0233	-0.9142	-0.5188	*****	*****	*****	*****	*****
0.875	*****	-1.1055	-1.0319	-0.8206	-0.4749	*****	*****	*****	*****	*****
0.900	-0.8271	-1.0950	-0.9925	-0.7590	-0.4584	*****	*****	*****	*****	*****
0.925	*****	-1.1069	-0.9370	-0.7139	-0.4552	*****	*****	*****	*****	*****
0.950	-1.2634	-1.3946	-0.9021	-0.6681	-0.3760	*****	*****	*****	*****	*****
0.975	*****	-1.3236	-0.8701	-0.6289	-0.3255	*****	*****	*****	*****	*****
1.000	-1.3015	-1.5273	-1.1868	-1.1183	-0.5165	*****	*****	*****	*****	*****
-0.200	$C_{p,l}$	0.2644	0.2493	0.2648	*****	*****	*****	*****	*****	*****
-0.400		0.2588	0.2588	0.2411	0.0747	-0.6103	*****	*****	*****	*****
-0.600		0.2781	0.2649	0.2397	0.1039	-0.6233	*****	*****	*****	*****
-0.700		0.2954	0.2637	0.2385	0.1253	-0.6139	*****	*****	*****	*****
-0.800		0.3131	*****	0.2455	0.1489	-0.5421	*****	*****	*****	*****
-0.850		*****	0.2942	0.2553	0.1591	-0.5415	*****	*****	*****	*****
-0.900		*****	0.2969	0.2657	0.1816	-0.5069	*****	*****	*****	*****
-0.950		0.2301	0.2448	0.2419	0.1927	-0.1698	*****	*****	*****	*****
-0.975		*****	0.1245	0.1549	0.1435	-0.0271	*****	*****	*****	*****
-1.000		-1.3153	-1.4257	-1.2437	-1.1911	-0.5144	*****	*****	*****	*****

Medium Radius L.E.
 Run No. = 24 , Point No. = 494
 $C_N = 0.560$, $C_m = -0.0949$
 $\alpha = 12.3^\circ$, $M_\infty = 0.802$
 $R_{mac} = 59.4 \times 10^6$

Leading Edge Pressures



x/c_R	starb'd C_p	port C_p
0.10	-0.8536	*****
0.20	-1.3015	-1.3153
0.30	-1.4775	*****
0.40	-1.5273	-1.4257
0.50	-1.5144	*****
0.60	-1.1868	-1.2437
0.70	-0.9557	*****
0.80	-1.1183	-1.1911
0.90	*****	*****
0.95	-0.5165	-0.5144

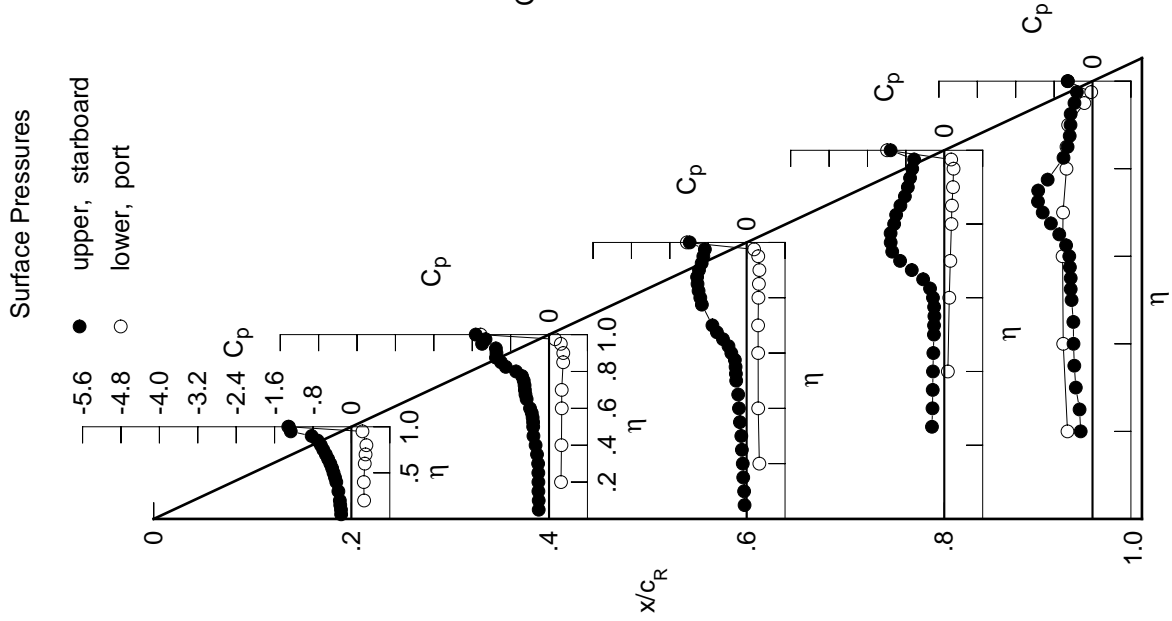
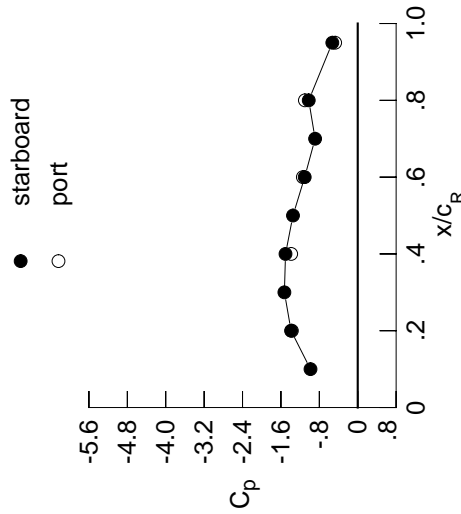

Table G1. Continued.

η	$x/c_R = .2$		$x/c_R = .4$		$x/c_R = .6$		$x/c_R = .8$		$x/c_R = .95$	
	$C_{p,u}$	$C_{p,u}$	$C_{p,u}$	$C_{p,u}$	$C_{p,u}$	$C_{p,u}$	$C_{p,u}$	$C_{p,u}$	$C_{p,u}$	$C_{p,u}$
0.050	-0.2378	-0.2536	-0.0647	*****	*****	*****	*****	*****	*****	*****
0.100	-0.2367	-0.2533	-0.0740	*****	*****	*****	*****	*****	*****	*****
0.150	-0.2520	-0.2572	-0.0916	*****	*****	*****	*****	*****	*****	*****
0.200	-0.2678	-0.2551	-0.1017	*****	*****	*****	*****	*****	*****	*****
0.250	*****	-0.2575	-0.1211	-0.2736	-0.2603	*****	*****	*****	*****	*****
0.300	-0.3047	-0.2699	-0.1362	-0.2642	-0.3294	*****	*****	*****	*****	*****
0.350	*****	-0.2989	-0.1664	-0.2567	-0.3474	*****	*****	*****	*****	*****
0.400	-0.3576	-0.3219	-0.1758	-0.2406	-0.3976	*****	*****	*****	*****	*****
0.450	-0.3792	-0.3745	-0.1621	-0.2284	-0.4498	*****	*****	*****	*****	*****
0.500	-0.4035	-0.3845	-0.1813	-0.2161	-0.4844	*****	*****	*****	*****	*****
0.525	*****	-0.3830	-0.1899	-0.2179	-0.4949	*****	*****	*****	*****	*****
0.550	-0.4308	-0.3871	-0.2115	-0.2246	-0.4955	*****	*****	*****	*****	*****
0.575	*****	-0.3993	-0.2655	-0.2565	-0.5272	*****	*****	*****	*****	*****
0.600	-0.4700	-0.4343	-0.4326	-0.3302	-0.5808	*****	*****	*****	*****	*****
0.625	*****	*****	-0.5793	-0.4675	-0.7004	*****	*****	*****	*****	*****
0.650	-0.5144	-0.5878	-0.7830	-0.6882	-0.8820	*****	*****	*****	*****	*****
0.675	*****	-0.6502	-0.9557	-0.9480	-1.0615	*****	*****	*****	*****	*****
0.700	-0.5660	-0.7018	-1.0381	-1.1613	-1.2151	*****	*****	*****	*****	*****
0.725	*****	-0.7674	*****	-1.2943	-1.2939	*****	*****	*****	*****	*****
0.750	-0.6060	-0.8639	*****	-1.2819	-0.8893	*****	*****	*****	*****	*****
0.775	*****	-0.9708	-1.0689	-1.2160	-0.6993	*****	*****	*****	*****	*****
0.800	-0.6428	-1.0527	-1.0733	-1.1218	*****	*****	*****	*****	*****	*****
0.825	*****	-1.0793	-1.0861	-1.0124	-0.5201	*****	*****	*****	*****	*****
0.850	-0.9616	-1.0974	-1.0715	-0.8793	-0.4778	*****	*****	*****	*****	*****
0.875	*****	-1.1287	-1.0296	-0.8174	-0.4705	*****	*****	*****	*****	*****
0.900	-1.2594	-1.0695	-0.9560	-0.7668	-0.4839	*****	*****	*****	*****	*****
0.925	*****	-1.0424	-0.9041	-0.7092	-0.4867	*****	*****	*****	*****	*****
0.950	-1.3828	-1.3423	-0.8710	-0.6447	-0.4161	*****	*****	*****	*****	*****
0.975	*****	-1.2942	-0.8379	-0.6047	-0.3536	*****	*****	*****	*****	*****
1.000	-1.3890	-1.5044	-1.1051	-1.0204	-0.5294	*****	*****	*****	*****	*****
-0.200	$C_{p,l}$	$C_{p,l}$	$C_{p,l}$	$C_{p,l}$	$C_{p,l}$	$C_{p,l}$	$C_{p,l}$	$C_{p,l}$	$C_{p,l}$	$C_{p,l}$
-0.400	0.2953	0.2769	0.2857	*****	-0.5171	*****	*****	*****	*****	*****
-0.600	0.2899	0.2849	0.2628	0.0891	-0.6360	*****	*****	*****	*****	*****
-0.700	0.3096	0.2922	0.2602	0.1205	-0.6429	*****	*****	*****	*****	*****
-0.800	0.3248	0.2898	0.2604	0.1416	-0.6196	*****	*****	*****	*****	*****
-0.850	0.3374	*****	0.2661	0.1662	-0.5406	*****	*****	*****	*****	*****
-0.900	*****	0.3162	0.2738	0.1754	-0.5376	*****	*****	*****	*****	*****
-0.950	0.2237	0.2460	0.2436	0.1977	-0.4971	*****	*****	*****	*****	*****
-0.975	*****	0.1102	0.1431	0.1365	-0.0281	*****	*****	*****	*****	*****
-1.000	-1.3722	-1.3863	-1.1429	-1.1011	-0.4702	*****	*****	*****	*****	*****

Medium Radius L.E.
 Run No. = 24 , Point No. = 495
 $C_N = 0.620$, $C_m = -0.1036$
 $\alpha = 13.3^\circ$, $M_\infty = 0.801$
 $R_{mac} = 59.3 \times 10^6$

Leading Edge Pressures



x/c_R	starb'd C_p	port C_p
0.10	-0.9844	*****
0.20	-1.3890	-1.3722
0.30	-1.5276	*****
0.40	-1.5044	-1.3863
0.50	-1.3491	*****
0.60	-1.1051	-1.1429
0.70	-0.8883	*****
0.80	-1.0204	-1.1011
0.90	*****	*****
0.95	-0.5294	-0.4702

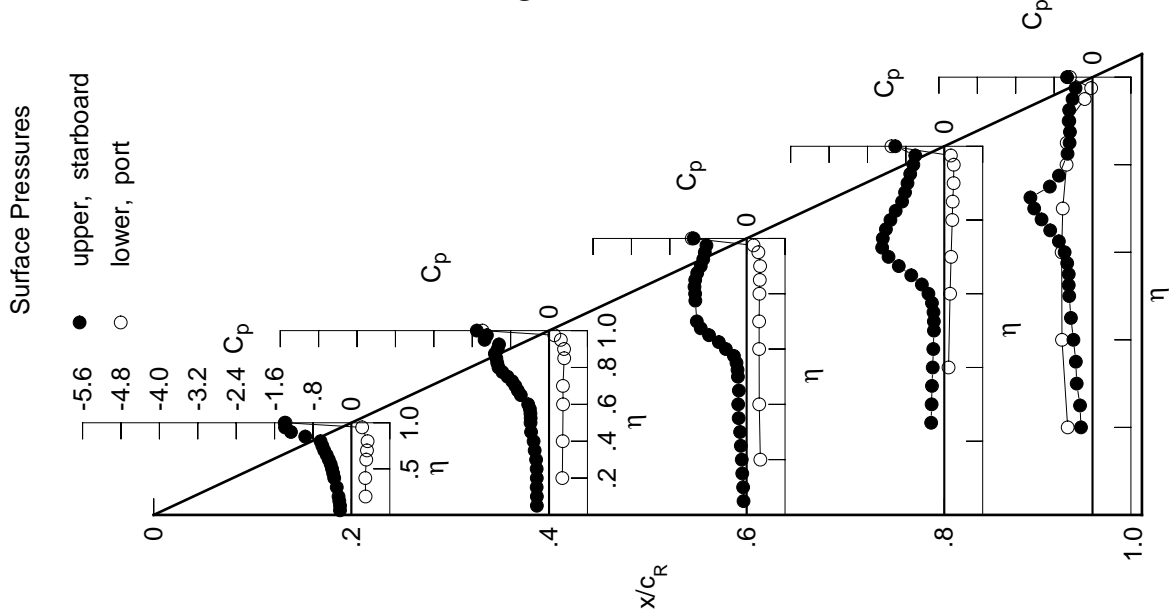
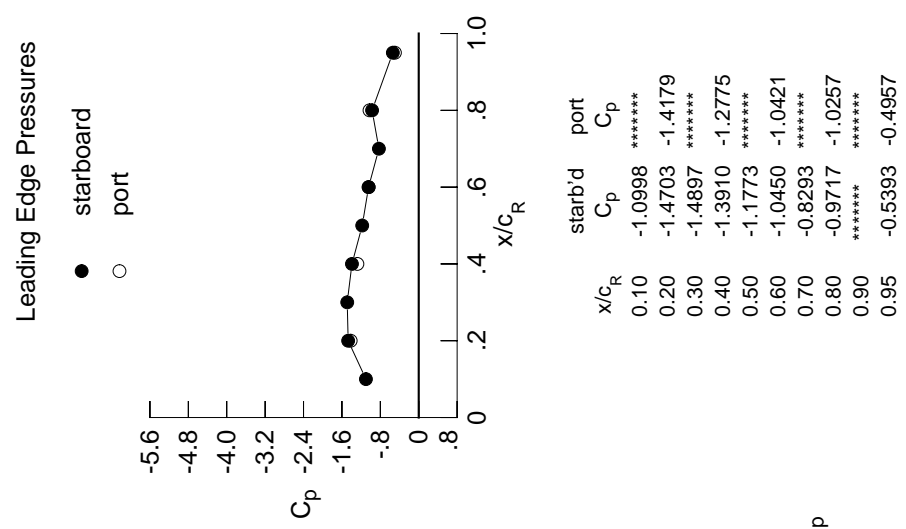

Table G1. Continued.

η	$x/c_R = .2$		$x/c_R = .4$		$x/c_R = .6$		$x/c_R = .8$		$x/c_R = .95$	
	$C_{p,u}$	$C_{p,u}$	$C_{p,u}$	$C_{p,u}$	$C_{p,u}$	$C_{p,u}$	$C_{p,u}$	$C_{p,u}$	$C_{p,u}$	$C_{p,u}$
0.050	-0.2628	-0.2891	-0.0856	*****	*****	*****	*****	*****	*****	*****
0.100	-0.2578	-0.2888	-0.0960	*****	*****	*****	*****	*****	*****	*****
0.150	-0.2714	-0.2927	-0.1101	*****	*****	*****	*****	*****	*****	*****
0.200	-0.2885	-0.2847	-0.1234	*****	*****	*****	*****	*****	*****	-0.3404
0.250	*****	-0.2946	-0.1527	-0.2852	-0.2852	-0.3272	*****	*****	*****	*****
0.300	-0.3505	-0.3188	-0.1655	-0.2735	-0.3296	*****	*****	*****	*****	*****
0.350	*****	-0.3464	-0.1757	-0.2614	-0.3502	*****	*****	*****	*****	*****
0.400	-0.3966	-0.3382	-0.1805	-0.2417	-0.4198	*****	*****	*****	*****	*****
0.450	-0.4111	-0.3349	-0.1618	-0.2347	-0.4659	*****	*****	*****	*****	*****
0.500	-0.4259	-0.3444	-0.1991	-0.2333	-0.4959	*****	*****	*****	*****	*****
0.525	*****	-0.3884	-0.2153	-0.2497	-0.5133	*****	*****	*****	*****	*****
0.550	-0.4483	-0.4397	-0.2517	-0.2811	-0.5307	*****	*****	*****	*****	*****
0.575	*****	-0.4976	-0.3258	-0.3522	-0.5907	*****	*****	*****	*****	*****
0.600	-0.4913	-0.5836	-0.5471	-0.4700	-0.6806	*****	*****	*****	*****	*****
0.625	*****	*****	-0.7644	-0.6460	-0.8270	*****	*****	*****	*****	*****
0.650	-0.5532	-0.8304	-1.0255	-0.8692	-1.0133	*****	*****	*****	*****	*****
0.675	*****	-0.9499	-1.2295	-1.0968	-1.1803	*****	*****	*****	*****	*****
0.700	-0.6546	-1.0539	-1.3161	-1.2793	-0.8277	*****	*****	*****	*****	*****
0.725	*****	-1.1378	*****	-1.4074	-0.7240	*****	*****	*****	*****	*****
0.750	-0.6813	-1.1946	*****	-1.4460	-0.6624	*****	*****	*****	*****	*****
0.775	*****	-1.2025	-1.2356	-1.1804	-0.6149	*****	*****	*****	*****	*****
0.800	-0.6213	-1.1800	-1.2120	-0.9720	*****	*****	*****	*****	*****	*****
0.825	*****	-1.1494	-1.1671	-0.8811	-0.5404	*****	*****	*****	*****	*****
0.850	-1.2739	-1.1421	-1.0772	-0.8512	-0.5079	*****	*****	*****	*****	*****
0.875	*****	-1.1608	-0.9883	-0.8570	-0.5199	*****	*****	*****	*****	*****
0.900	-1.4646	-1.1363	-0.9112	-0.8314	-0.4987	*****	*****	*****	*****	*****
0.925	*****	-1.1095	-0.8711	-0.7066	-0.4980	*****	*****	*****	*****	*****
0.950	-1.4892	-1.2420	-0.8318	-0.6709	-0.4476	*****	*****	*****	*****	*****
0.975	*****	-1.1487	-0.7971	-0.6401	-0.3784	*****	*****	*****	*****	*****
1.000	-1.4703	-1.3910	-1.0450	-0.9717	-0.5393	*****	*****	*****	*****	*****
-0.200	$C_{p,l}$	$C_{p,l}$	$C_{p,l}$	$C_{p,l}$	$C_{p,l}$	$C_{p,l}$	$C_{p,l}$	$C_{p,l}$	$C_{p,l}$	$C_{p,l}$
-0.400	0.3257	0.3013	0.3046	*****	*****	-0.5177	*****	*****	*****	*****
-0.600	0.3188	0.3106	0.2807	0.1062	-0.6412	*****	*****	*****	*****	*****
-0.700	0.3375	0.3165	0.2797	0.1353	-0.6497	*****	*****	*****	*****	*****
-0.800	0.3507	0.3126	0.2791	0.1564	-0.6192	*****	*****	*****	*****	*****
-0.850	0.3581	*****	0.2827	0.1796	-0.5361	*****	*****	*****	*****	*****
-0.900	*****	0.3340	0.2892	0.1866	-0.5326	*****	*****	*****	*****	*****
-0.950	*****	0.3229	0.2907	0.2042	-0.4876	*****	*****	*****	*****	*****
-0.975	0.2153	0.2432	0.2423	0.1964	-0.1617	*****	*****	*****	*****	*****
-1.000	0.0923	0.1296	0.1232	0.10386	*****	*****	*****	*****	*****	*****
	-1.4179	-1.2775	-1.0421	-1.0257	-0.4957	*****	*****	*****	*****	*****

Medium Radius L.E.
 Run No. = 24 , Point No. = 496
 $C_N = 0.676$, $C_m = -0.1089$
 $\alpha = 14.4^\circ$, $M_\infty = 0.802$
 $R_{mac} = 59.6 \times 10^6$



x/c_R	starb'd C_p	port C_p
0.10	-1.0998	*****
0.20	-1.4703	-1.4179
0.30	-1.4897	*****
0.40	-1.3910	-1.2775
0.50	-1.1773	*****
0.60	-1.0450	-1.0421
0.70	-0.8293	*****
0.80	-0.9717	-1.0257
0.90	*****	*****
0.95	-0.5393	-0.4957

Table G1. Continued.

η	$x/c_R = .2$		$x/c_R = .4$		$x/c_R = .6$		$x/c_R = .8$		$x/c_R = .95$	
	$C_{p,u}$	$C_{p,u}$	$C_{p,u}$	$C_{p,u}$	$C_{p,u}$	$C_{p,u}$	$C_{p,u}$	$C_{p,u}$	$C_{p,u}$	$C_{p,u}$
0.050	-0.3291	-0.3637	-0.1256	*****	*****	*****	*****	*****	*****	*****
0.100	-0.3209	-0.3643	-0.1367	*****	*****	*****	*****	*****	*****	*****
0.150	-0.3314	-0.3610	-0.1480	*****	*****	*****	*****	*****	*****	*****
0.200	-0.3379	-0.3573	-0.1648	*****	*****	*****	*****	*****	*****	-0.4104
0.250	*****	-0.3768	-0.1935	-0.3058	-0.4126	*****	*****	*****	*****	*****
0.300	-0.4452	-0.3953	-0.2068	-0.2947	-0.4311	*****	*****	*****	*****	*****
0.350	*****	-0.4165	-0.2238	-0.2880	-0.4345	*****	*****	*****	*****	*****
0.400	-0.4655	-0.4111	-0.2378	-0.2787	-0.4768	*****	*****	*****	*****	*****
0.450	-0.4764	-0.4162	-0.2309	-0.2887	-0.5159	*****	*****	*****	*****	*****
0.500	-0.5092	-0.4237	-0.3074	-0.3350	-0.5756	*****	*****	*****	*****	*****
0.525	*****	-0.4628	-0.3764	-0.3910	-0.6366	*****	*****	*****	*****	*****
0.550	-0.5605	-0.5403	-0.4878	-0.4778	-0.7023	*****	*****	*****	*****	*****
0.575	*****	-0.6865	-0.6404	-0.6062	-0.8221	*****	*****	*****	*****	*****
0.600	-0.6588	-0.9043	-0.9015	-0.7685	-0.9443	*****	*****	*****	*****	*****
0.625	*****	*****	-1.1124	-0.9518	-1.0744	*****	*****	*****	*****	*****
0.650	-0.6926	-1.3427	-1.3091	-1.1448	-0.6339	*****	*****	*****	*****	*****
0.675	*****	-1.4656	-1.4770	-1.3204	-0.5011	*****	*****	*****	*****	*****
0.700	-0.7190	-1.5295	-1.5719	-1.0707	-0.4450	*****	*****	*****	*****	*****
0.725	*****	-1.5636	*****	-0.9351	-0.4271	*****	*****	*****	*****	*****
0.750	-0.9347	-1.5508	*****	-0.9119	-0.4137	*****	*****	*****	*****	*****
0.775	*****	-1.4670	-1.3465	-0.9162	-0.4155	*****	*****	*****	*****	*****
0.800	-1.3867	-1.4108	-1.2111	-0.9425	*****	*****	*****	*****	*****	*****
0.825	*****	-1.3299	-1.0989	-0.9870	-0.4186	*****	*****	*****	*****	*****
0.850	-1.5584	-1.2574	-1.0379	-1.0296	-0.4094	*****	*****	*****	*****	*****
0.875	*****	-1.2217	-1.0185	-0.9310	-0.4086	*****	*****	*****	*****	*****
0.900	-1.5105	-1.1977	-1.0098	-0.8206	-0.3921	*****	*****	*****	*****	*****
0.925	*****	-1.1607	-0.9220	-0.7979	-0.3630	*****	*****	*****	*****	*****
0.950	-1.4821	-1.1273	-0.8561	-0.8233	-0.3166	*****	*****	*****	*****	*****
0.975	*****	-1.0963	-0.8409	-0.7691	-0.2725	*****	*****	*****	*****	*****
1.000	-1.5874	-1.2483	-1.0218	-0.9782	-0.3543	*****	*****	*****	*****	*****
	$C_{p,l}$	$C_{p,l}$	$C_{p,l}$	$C_{p,l}$	$C_{p,l}$	$C_{p,l}$	$C_{p,l}$	$C_{p,l}$	$C_{p,l}$	$C_{p,l}$
-0.200	0.3830	0.3480	0.3386	*****	-0.4945	*****	*****	*****	*****	*****
-0.400	0.3754	0.3570	0.3163	0.1339	-0.6548	*****	*****	*****	*****	*****
-0.600	0.3922	0.3611	0.3145	0.1620	-0.6471	*****	*****	*****	*****	*****
-0.700	0.4002	0.3559	0.3139	0.1831	-0.6118	*****	*****	*****	*****	*****
-0.800	0.3969	*****	0.3132	0.2045	-0.5215	*****	*****	*****	*****	*****
-0.850	*****	0.3641	0.3156	0.2078	-0.5156	*****	*****	*****	*****	*****
-0.900	*****	0.3396	0.3063	0.2199	-0.4637	*****	*****	*****	*****	*****
-0.950	0.2003	0.2332	0.2330	0.1911	-0.1504	*****	*****	*****	*****	*****
-0.975	*****	0.0515	0.0934	0.0914	-0.0469	*****	*****	*****	*****	*****
-1.000	-1.4987	-1.2074	-0.9507	-0.9539	-0.4763	*****	*****	*****	*****	*****

Medium Radius L.E.

Run No. = 24 , Point No. = 497

$C_N = 0.772$, $C_m = -0.1125$

$\alpha = 16.5^\circ$, $M_\infty = 0.800$

$R_{mac} = 59.6 \times 10^6$

Leading Edge Pressures

● starboard
○ port

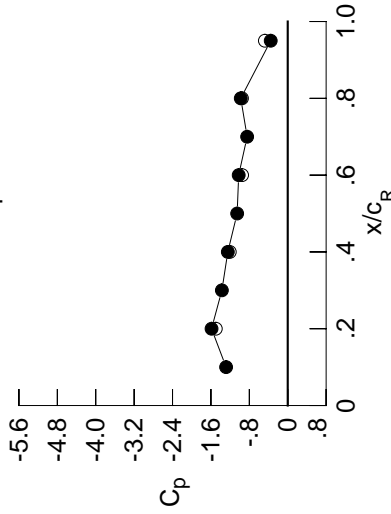

x/c_R	starb'd C_p	port C_p
0.10	-1.2839	*****
0.20	-1.5874	-1.4987
0.30	-1.3716	*****
0.40	-1.2483	-1.2074
0.50	-1.0539	*****
0.60	-1.0218	-0.9507
0.70	-0.8455	*****
0.80	-0.9782	-0.9539
0.90	*****	*****
0.95	-0.3543	-0.4763

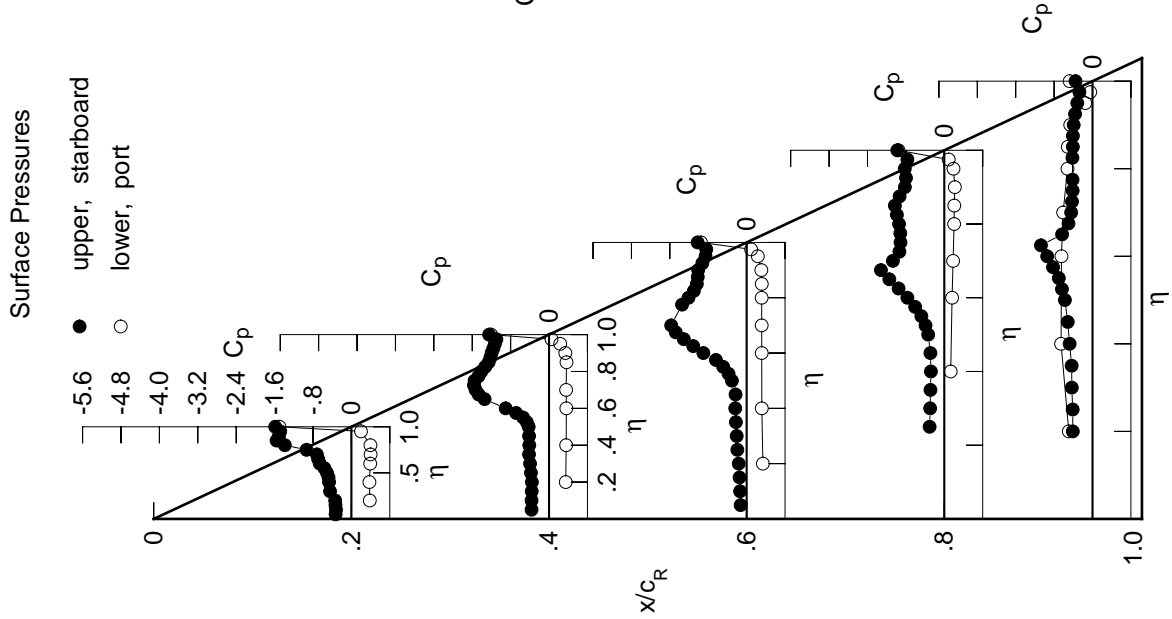

Table G1. Continued.

η	$x/c_R = .2$		$x/c_R = .4$		$x/c_R = .6$		$x/c_R = .8$		$x/c_R = .95$	
	$C_{p,u}$	$C_{p,u}$	$C_{p,u}$	$C_{p,u}$	$C_{p,u}$	$C_{p,u}$	$C_{p,u}$	$C_{p,u}$	$C_{p,u}$	$C_{p,u}$
0.050	-0.4150	-0.4461	-0.1624	*****	*****	*****	*****	*****	*****	*****
0.100	-0.4053	-0.4427	-0.1717	*****	*****	*****	*****	*****	*****	*****
0.150	-0.4073	-0.4368	-0.1848	*****	*****	*****	*****	*****	*****	*****
0.200	-0.4567	-0.4586	-0.2105	*****	*****	*****	*****	*****	*****	-0.4690
0.250	*****	-0.4532	-0.2234	-0.3458	-0.3458	-0.4888	-0.4888	-0.4888	-0.4888	-0.4888
0.300	-0.4642	-0.4488	-0.2334	-0.3378	-0.3378	-0.5092	-0.5092	-0.5092	-0.5092	-0.5092
0.350	*****	-0.4518	-0.2534	-0.3347	-0.3347	-0.5279	-0.5279	-0.5279	-0.5279	-0.5279
0.400	-0.4849	-0.4539	-0.2885	-0.3399	-0.3399	-0.5988	-0.5988	-0.5988	-0.5988	-0.5988
0.450	-0.5085	-0.5083	-0.3394	-0.3892	-0.3892	-0.6661	-0.6661	-0.6661	-0.6661	-0.6661
0.500	-0.5615	-0.6767	-0.5421	-0.5041	-0.5041	-0.7719	-0.7719	-0.7719	-0.7719	-0.7719
0.525	*****	-0.8568	-0.6966	-0.6057	-0.6057	-0.8528	-0.8528	-0.8528	-0.8528	-0.8528
0.550	-0.6776	-1.0745	-0.8792	-0.7334	-0.7334	-0.9368	-0.9368	-0.9368	-0.9368	-0.9368
0.575	*****	-1.2773	-1.0638	-0.8918	-1.0545	-1.0545	-1.0545	-1.0545	-1.0545	-1.0545
0.600	-1.0458	-1.4425	-1.2838	-1.0566	-1.0566	-0.9536	-0.9536	-0.9536	-0.9536	-0.9536
0.625	*****	*****	-1.4313	-1.2189	-0.5772	-0.5772	-0.5772	-0.5772	-0.5772	-0.5772
0.650	-1.3755	-1.6482	-1.5503	-1.2677	-0.4560	-0.4560	-0.4560	-0.4560	-0.4560	-0.4560
0.675	*****	-1.6735	-1.6617	-0.9174	-0.4146	-0.4146	-0.4146	-0.4146	-0.4146	-0.4146
0.700	-1.2583	-1.6504	-1.6588	-0.8725	-0.4168	-0.4168	-0.4168	-0.4168	-0.4168	-0.4168
0.725	*****	-1.6110	*****	-0.8676	-0.4267	-0.4267	-0.4267	-0.4267	-0.4267	-0.4267
0.750	-1.1907	-1.5822	*****	-0.8652	-0.4246	-0.4246	-0.4246	-0.4246	-0.4246	-0.4246
0.775	*****	-1.4969	-1.3294	-0.8846	-0.4288	-0.4288	-0.4288	-0.4288	-0.4288	-0.4288
0.800	-1.3628	-1.4098	-1.2561	-0.9186	*****	*****	*****	*****	*****	*****
0.825	*****	-1.3312	-1.2129	-0.9343	-0.4135	-0.4135	-0.4135	-0.4135	-0.4135	-0.4135
0.850	-1.6316	-1.2801	-1.1813	-0.9504	-0.3998	-0.3998	-0.3998	-0.3998	-0.3998	-0.3998
0.875	*****	-1.2493	-1.1779	-0.9062	-0.3835	-0.3835	-0.3835	-0.3835	-0.3835	-0.3835
0.900	-1.4490	-1.2313	-1.0843	-0.8827	-0.3643	-0.3643	-0.3643	-0.3643	-0.3643	-0.3643
0.925	*****	-1.2117	-0.9633	-0.8959	-0.3474	-0.3474	-0.3474	-0.3474	-0.3474	-0.3474
0.950	-1.4371	-1.1868	-0.9237	-0.9113	-0.3246	-0.3246	-0.3246	-0.3246	-0.3246	-0.3246
0.975	*****	-1.1167	-0.9135	-0.8558	-0.2990	-0.2990	-0.2990	-0.2990	-0.2990	-0.2990
1.000	-1.6346	-1.2511	-1.0218	-0.9792	-0.3603	-0.3603	-0.3603	-0.3603	-0.3603	-0.3603
-0.200	$C_{p,l}$	$C_{p,l}$	$C_{p,l}$	$C_{p,l}$	$C_{p,l}$	$C_{p,l}$	$C_{p,l}$	$C_{p,l}$	$C_{p,l}$	$C_{p,l}$
-0.400	0.4392	0.3953	0.3738	*****	*****	-0.5318	-0.5318	-0.5318	-0.5318	-0.5318
-0.600	0.4323	0.4036	0.3519	0.1622	-0.6539	-0.6539	-0.6539	-0.6539	-0.6539	-0.6539
-0.700	0.4467	0.4054	0.3482	0.1890	-0.6398	-0.6398	-0.6398	-0.6398	-0.6398	-0.6398
-0.800	0.4484	0.3986	0.3474	0.2097	-0.6007	-0.6007	-0.6007	-0.6007	-0.6007	-0.6007
-0.850	0.4332	*****	0.3423	0.2289	-0.5063	-0.5063	-0.5063	-0.5063	-0.5063	-0.5063
-0.900	*****	0.3912	0.3390	0.2307	-0.4973	-0.4973	-0.4973	-0.4973	-0.4973	-0.4973
-0.950	0.1848	0.2186	0.2151	0.1814	-0.4418	-0.4418	-0.4418	-0.4418	-0.4418	-0.4418
-0.975	*****	0.0086	0.0459	0.0502	-0.0555	-0.0555	-0.0555	-0.0555	-0.0555	-0.0555
-1.000	-1.5118	-1.1956	-0.9916	-0.9760	-0.4183	-0.4183	-0.4183	-0.4183	-0.4183	-0.4183

Medium Radius L.E.
 Run No. = 24 , Point No. = 498
 $C_N = 0.865$, $C_m = -0.1169$
 $\alpha = 18.5^\circ$, $M_\infty = 0.800$
 $R_{mac} = 59.5 \times 10^6$

Leading Edge Pressures

● starboard
 ○ port

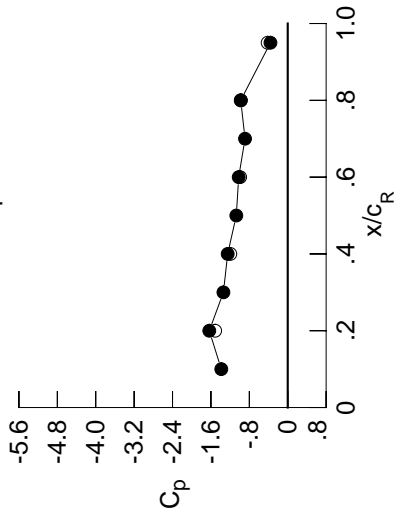

x/c_R	starb'd C_p	port C_p
0.10	-1.3840	*****
0.20	-1.6346	-1.5118
0.30	-1.3397	*****
0.40	-1.2511	-1.1956
0.50	-1.0713	*****
0.60	-1.0218	-0.9916
0.70	-0.8895	*****
0.80	-0.9792	-0.9760
0.90	*****	*****
0.95	-0.3603	-0.4183

Surface Pressures

● upper, starboard
 ○ lower, port

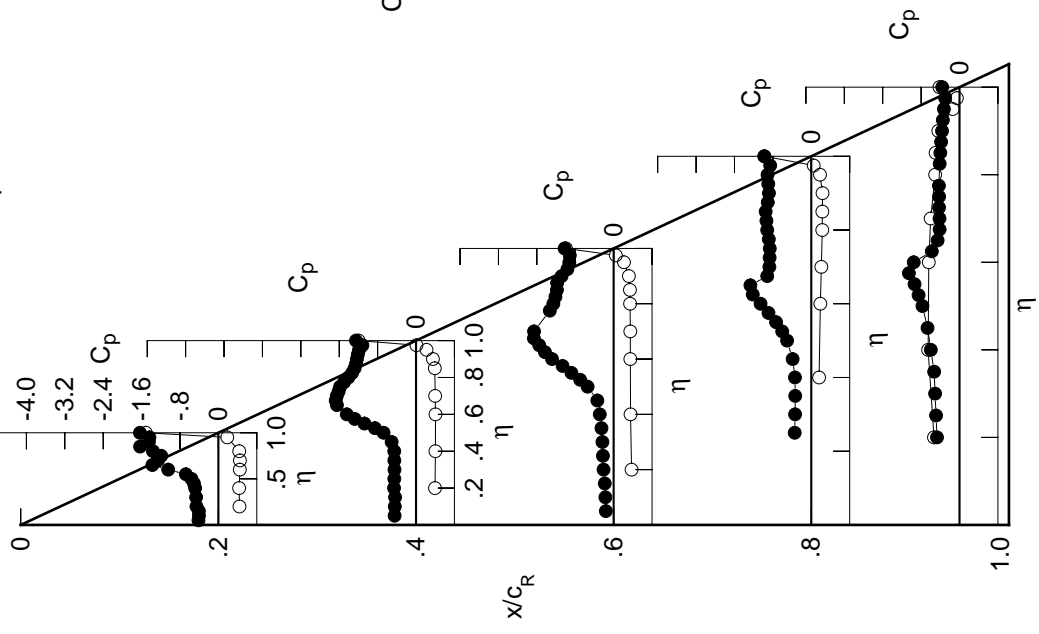
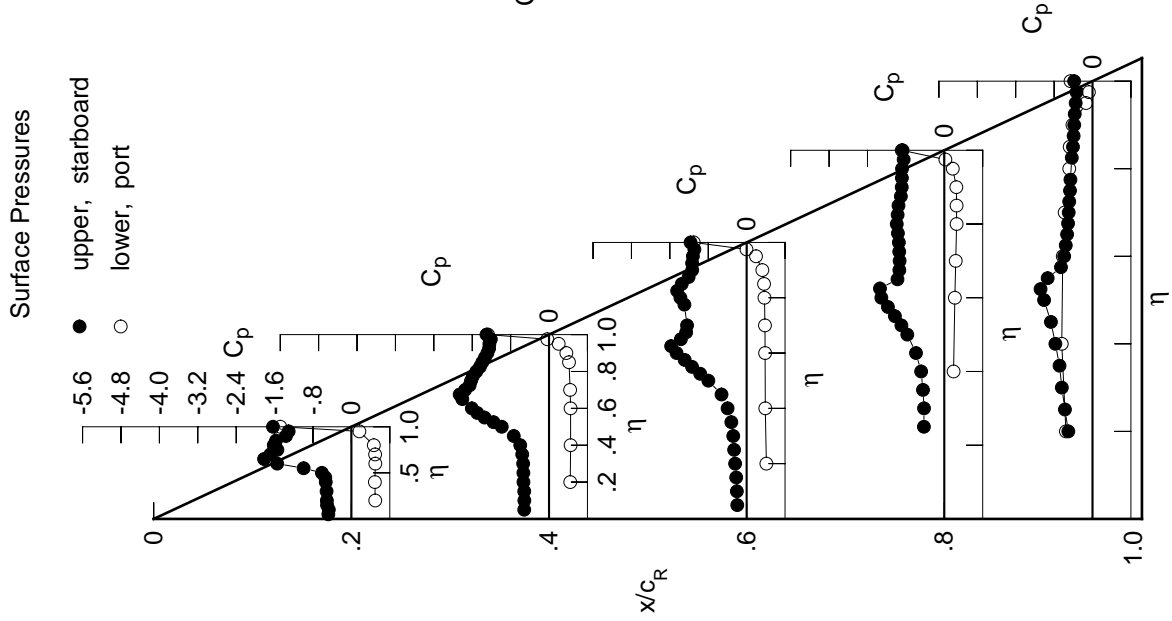
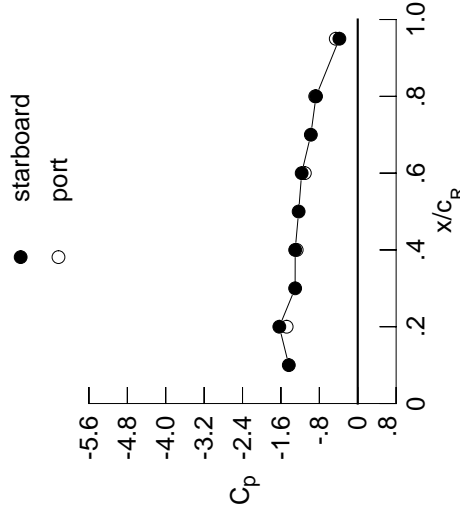

Table G1. Continued.

η	$x/c_R = .2$		$x/c_R = .4$		$x/c_R = .6$		$x/c_R = .8$		$x/c_R = .95$	
	$C_{p,u}$	$C_{p,u}$	$C_{p,u}$	$C_{p,u}$	$C_{p,u}$	$C_{p,u}$	$C_{p,u}$	$C_{p,u}$	$C_{p,u}$	$C_{p,u}$
0.050	-0.4796	-0.5168	-0.1955	*****	*****	*****	*****	*****	*****	*****
0.100	-0.4704	-0.5144	-0.2043	*****	*****	*****	*****	*****	*****	*****
0.150	-0.5071	-0.5170	-0.2179	*****	*****	*****	*****	*****	*****	*****
0.200	-0.5111	-0.5332	-0.2397	*****	*****	*****	*****	*****	*****	*****
0.250	*****	-0.5348	-0.2612	-0.4245	-0.5744	*****	*****	*****	*****	*****
0.300	-0.5164	-0.5393	-0.2792	-0.4224	-0.6395	*****	*****	*****	*****	*****
0.350	*****	-0.5587	-0.3194	-0.4440	-0.6875	*****	*****	*****	*****	*****
0.400	-0.5345	-0.6000	-0.3968	-0.4826	-0.7732	*****	*****	*****	*****	*****
0.450	-0.5442	-0.7352	-0.5232	-0.5899	-0.8668	*****	*****	*****	*****	*****
0.500	-0.6143	-0.9845	-0.7979	-0.7701	-1.0091	*****	*****	*****	*****	*****
0.525	*****	-1.1569	-0.9672	-0.8938	-1.0824	*****	*****	*****	*****	*****
0.550	-0.9950	-1.3432	-1.1368	-1.0285	-0.9344	*****	*****	*****	*****	*****
0.575	*****	-1.4951	-1.2906	-1.1748	-0.6565	*****	*****	*****	*****	*****
0.600	-1.5459	-1.6078	-1.4600	-1.3111	-0.5907	*****	*****	*****	*****	*****
0.625	*****	*****	-1.5728	-1.3397	-0.5575	*****	*****	*****	*****	*****
0.650	-1.8195	-1.8061	-1.3707	-0.9751	-0.5294	*****	*****	*****	*****	*****
0.675	*****	-1.8623	-1.2600	-0.9363	-0.5097	*****	*****	*****	*****	*****
0.700	-1.6880	-1.7479	-1.2412	-0.9301	-0.4958	*****	*****	*****	*****	*****
0.725	*****	-1.6547	*****	-0.9386	-0.4856	*****	*****	*****	*****	*****
0.750	-1.5419	-1.6250	*****	-0.9465	-0.4688	*****	*****	*****	*****	*****
0.775	*****	-1.5854	-1.2970	-0.9661	-0.4603	*****	*****	*****	*****	*****
0.800	-1.6173	-1.5142	-1.3798	-0.9902	*****	*****	*****	*****	*****	*****
0.825	*****	-1.4398	-1.4472	-0.9720	-0.4318	*****	*****	*****	*****	*****
0.850	-1.5701	-1.3899	-1.3509	-0.9534	-0.4071	*****	*****	*****	*****	*****
0.875	*****	-1.3360	-1.2085	-0.9049	-0.3935	*****	*****	*****	*****	*****
0.900	-1.3624	-1.2839	-1.1339	-0.8861	-0.3806	*****	*****	*****	*****	*****
0.925	*****	-1.2490	-1.1363	-0.8834	-0.3701	*****	*****	*****	*****	*****
0.950	-1.3071	-1.2429	-1.1204	-0.8798	-0.3505	*****	*****	*****	*****	*****
0.975	*****	-1.2126	-1.0887	-0.8467	-0.3338	*****	*****	*****	*****	*****
1.000	-1.6336	-1.3029	-1.1680	-0.8692	-0.3823	*****	*****	*****	*****	*****
-0.200	$C_{p,l}$	$C_{p,l}$	$C_{p,l}$	$C_{p,l}$	$C_{p,l}$	$C_{p,l}$	$C_{p,l}$	$C_{p,l}$	$C_{p,l}$	$C_{p,l}$
-0.400	0.4969	0.4420	0.4112	*****	*****	*****	*****	*****	*****	*****
-0.600	0.4893	0.4497	0.3885	0.1936	-0.6404	*****	*****	*****	*****	*****
-0.700	0.4987	0.4486	0.3848	0.2200	-0.6198	*****	*****	*****	*****	*****
-0.800	0.4942	0.4395	0.3814	0.2387	-0.5796	*****	*****	*****	*****	*****
-0.850	0.4669	*****	0.3716	0.2567	-0.4851	*****	*****	*****	*****	*****
-0.900	*****	0.4158	0.3624	0.2559	-0.4752	*****	*****	*****	*****	*****
-0.950	*****	0.3608	0.3276	0.2515	-0.4175	*****	*****	*****	*****	*****
-0.975	0.1666	0.2012	0.1955	0.1767	-0.1361	*****	*****	*****	*****	*****
-1.000	*****	-0.0364	-0.0034	0.0224	-0.0749	*****	*****	*****	*****	*****
	-1.4806	-1.2712	-1.1013	-0.8867	-0.4574	*****	*****	*****	*****	*****

Medium Radius L.E.
 Run No. = 24 , Point No. = 499
 $C_N = 0.972$, $C_m = -0.1313$
 $\alpha = 20.6^\circ$, $M_\infty = 0.801$
 $R_{mac} = 59.7 \times 10^6$

Leading Edge Pressures



x/c_R	starb'd C_p	port C_p
0.10	-1.4358	*****
0.20	-1.6336	-1.4806
0.30	-1.3043	*****
0.40	-1.3029	-1.2712
0.50	-1.2308	*****
0.60	-1.1680	-1.1013
0.70	-0.9772	*****
0.80	-0.8692	-0.8867
0.90	*****	*****
0.95	-0.3823	-0.4574

Table G1. Continued.

η	$x/c_R = .2$		$x/c_R = .4$		$x/c_R = .6$		$x/c_R = .8$		$x/c_R = .95$	
	$C_{p,u}$	$C_{p,l}$	$C_{p,u}$	$C_{p,l}$	$C_{p,u}$	$C_{p,l}$	$C_{p,u}$	$C_{p,l}$	$C_{p,u}$	$C_{p,l}$
0.050	-0.5619	-0.6110	-0.2435	*****	*****	*****	*****	*****	*****	*****
0.100	-0.5538	-0.6103	-0.2567	*****	*****	*****	*****	*****	*****	*****
0.150	-0.5913	-0.6055	-0.2767	*****	*****	*****	*****	*****	*****	*****
0.200	-0.5904	-0.6221	-0.3036	*****	*****	*****	*****	*****	*****	-0.4722
0.250	*****	-0.6443	-0.3462	-0.4890	-0.5812	*****	*****	*****	*****	*****
0.300	-0.5975	-0.6627	-0.3960	-0.4965	-0.6597	*****	*****	*****	*****	*****
0.350	*****	-0.7173	-0.4903	-0.5351	-0.7184	*****	*****	*****	*****	*****
0.400	-0.6371	-0.8130	-0.6385	-0.6130	-0.8284	*****	*****	*****	*****	*****
0.450	-0.7274	-0.9996	-0.8352	-0.7660	-0.9594	*****	*****	*****	*****	*****
0.500	-1.0045	-1.2382	-1.1234	-0.9823	-1.1447	*****	*****	*****	*****	*****
0.525	*****	-1.3744	-1.2692	-1.1125	-1.1972	*****	*****	*****	*****	*****
0.550	-1.4709	-1.5255	-1.4046	-1.2410	-0.7169	*****	*****	*****	*****	*****
0.575	*****	-1.6424	-1.5201	-1.3709	-0.6323	*****	*****	*****	*****	*****
0.600	-1.8184	-1.7433	-1.6399	-1.4849	-0.6017	*****	*****	*****	*****	*****
0.625	*****	*****	-1.6345	-1.1392	-0.5881	*****	*****	*****	*****	*****
0.650	-1.9965	-1.6704	-1.3678	-1.0679	-0.5658	*****	*****	*****	*****	*****
0.675	*****	-1.5959	-1.3580	-1.0551	-0.5424	*****	*****	*****	*****	*****
0.700	-1.8332	-1.5673	-1.3605	-1.0557	-0.5144	*****	*****	*****	*****	*****
0.725	*****	-1.5630	*****	-1.0761	-0.4976	*****	*****	*****	*****	*****
0.750	-1.7472	-1.5538	*****	-1.1099	-0.4798	*****	*****	*****	*****	*****
0.775	*****	-1.5525	-1.4023	-1.1512	-0.4879	*****	*****	*****	*****	*****
0.800	-1.5537	-1.5878	-1.4451	-1.1812	*****	*****	*****	*****	*****	*****
0.825	*****	-1.5708	-1.4395	-1.1444	-0.5073	*****	*****	*****	*****	*****
0.850	-1.5347	-1.4794	-1.3462	-1.1104	-0.4909	*****	*****	*****	*****	*****
0.875	*****	-1.3956	-1.2497	-1.0018	-0.4981	*****	*****	*****	*****	*****
0.900	-1.4040	-1.3706	-1.2022	-0.9250	-0.4972	*****	*****	*****	*****	*****
0.925	*****	-1.3877	-1.2063	-0.8951	-0.5085	*****	*****	*****	*****	*****
0.950	-1.3453	-1.4000	-1.2164	-0.8919	-0.4560	*****	*****	*****	*****	*****
0.975	*****	-1.3708	-1.2063	-0.8665	-0.4299	*****	*****	*****	*****	*****
1.000	-1.6447	-1.4293	-1.2389	-0.8375	-0.4680	*****	*****	*****	*****	*****
-0.200	$C_{p,l}$	0.4874	0.4465	*****	-0.5347	*****	*****	*****	*****	*****
-0.400	0.5413	0.4942	0.4246	0.2262	-0.6148	*****	*****	*****	*****	*****
-0.600	0.5455	0.4894	0.4187	0.2499	-0.5912	*****	*****	*****	*****	*****
-0.700	0.5337	0.4769	0.4133	0.2679	-0.5523	*****	*****	*****	*****	*****
-0.800	0.4930	*****	0.3987	0.2815	-0.4579	*****	*****	*****	*****	*****
-0.850	*****	0.4346	0.3827	0.2773	-0.4491	*****	*****	*****	*****	*****
-0.900	*****	0.3635	0.3335	0.2635	-0.3904	*****	*****	*****	*****	*****
-0.950	0.1418	0.1774	0.1734	0.1658	-0.1303	*****	*****	*****	*****	*****
-0.975	*****	-0.0851	-0.0514	-0.0130	-0.0954	*****	*****	*****	*****	*****
-1.000	-1.4150	-1.4037	-1.1904	-0.8637	-0.5228	*****	*****	*****	*****	*****

Medium Radius L.E.
 Run No. = 24 , Point No. = 500
 $C_N = 1.084$, $C_m = -0.1489$
 $\alpha = 22.6^\circ$, $M_\infty = 0.801$
 $R_{mac} = 59.3 \times 10^6$

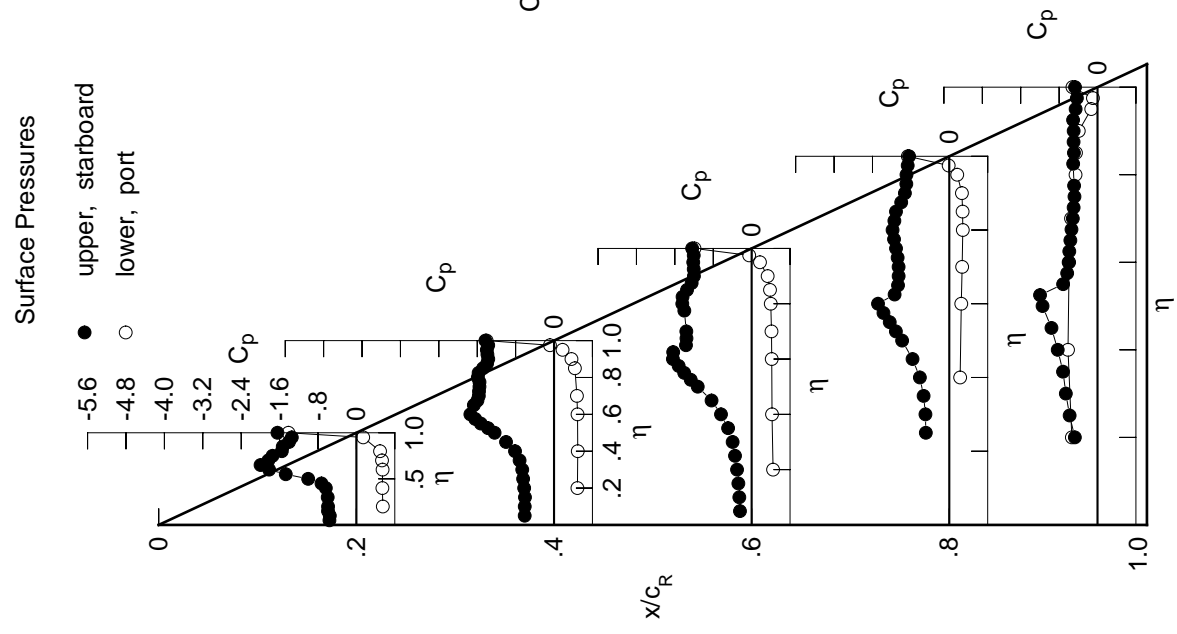
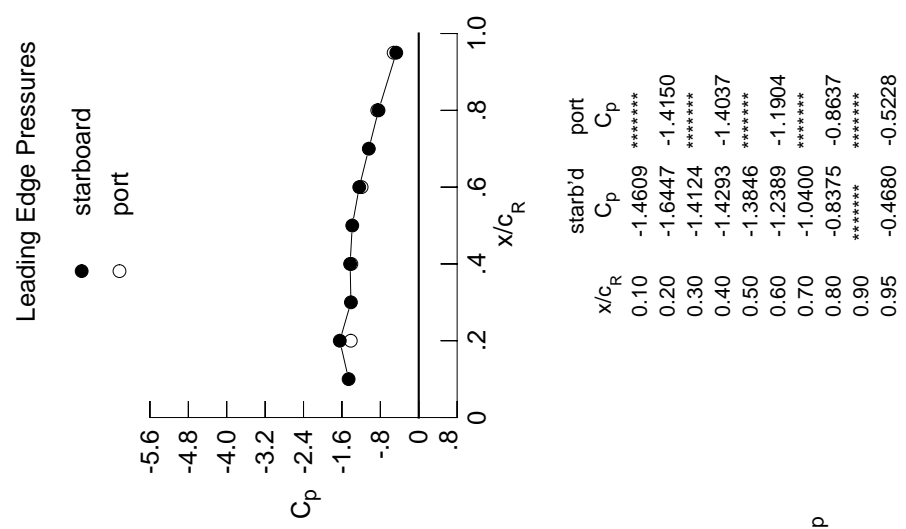
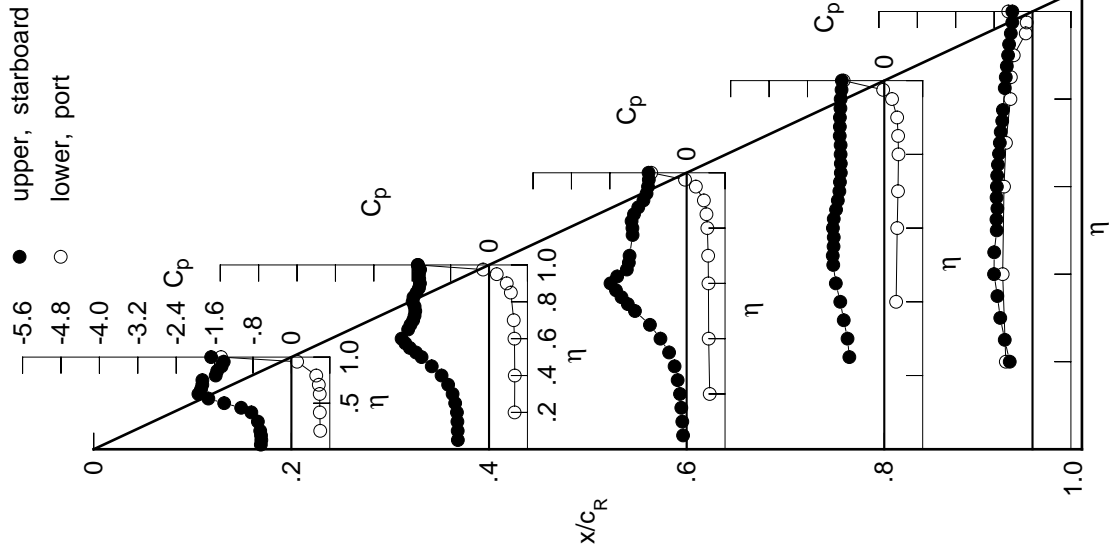

Table G1. Continued.

η	x/c_R .2	x/c_R .4	x/c_R .6	x/c_R .8	x/c_R .95
	$C_{p,u}$	$C_{p,u}$	$C_{p,u}$	$C_{p,u}$	$C_{p,u}$
0.050	-0.6369	-0.6498	-0.0744	*****	*****
0.100	-0.6268	-0.6529	-0.0902	*****	*****
0.150	-0.6330	-0.6594	-0.1109	*****	*****
0.200	-0.6498	-0.6687	-0.1387	*****	-0.4745
0.250	*****	-0.7059	-0.1873	-0.7281	-0.5787
0.300	-0.6988	-0.7591	-0.2511	-0.7659	-0.6716
0.350	*****	-0.8523	-0.3659	-0.8446	-0.7322
0.400	-0.8344	-0.9885	-0.5452	-0.9166	-0.8018
0.450	-1.0462	-1.1939	-0.7645	-1.0097	-0.7981
0.500	-1.3997	-1.4060	-1.0769	-1.0635	-0.7454
0.525	*****	-1.5212	-1.2254	-1.0739	-0.7508
0.550	-1.7304	-1.6509	-1.3571	-1.0567	-0.7320
0.575	*****	-1.7443	-1.4720	-1.0524	-0.7490
0.600	-1.9379	-1.8220	-1.5867	-1.0705	-0.7425
0.625	*****	*****	-1.4473	-1.0527	-0.7357
0.650	-1.8831	-1.6851	-1.2464	-1.0045	-0.7204
0.675	*****	-1.6377	-1.2042	-0.9678	-0.6981
0.700	-1.8557	-1.5811	-1.1886	-0.9364	-0.6805
0.725	*****	-1.5511	*****	-0.9240	-0.6622
0.750	-1.8548	-1.5368	*****	-0.9053	-0.6315
0.775	*****	-1.5506	-1.1262	-0.9054	-0.6166
0.800	-1.5767	-1.5918	-1.1295	-0.9095	*****
0.825	*****	-1.5745	-1.1473	-0.9097	-0.5783
0.850	-1.5460	-1.5102	-1.0970	-0.9277	-0.5569
0.875	*****	-1.4602	-1.0080	-0.9259	-0.5354
0.900	-1.4546	-1.4393	-0.9003	-0.9248	-0.5085
0.925	*****	-1.4542	-0.8353	-0.9133	-0.4882
0.950	-1.4092	-1.4609	-0.8047	-0.9087	-0.4522
0.975	*****	-1.4360	-0.7877	-0.8904	-0.4214
1.000	-1.6723	-1.4848	-0.7939	-0.8844	-0.4202
	$C_{p,l}$	$C_{p,l}$	$C_{p,l}$	$C_{p,l}$	$C_{p,l}$
-0.200	0.6010	0.5320	0.4806	*****	-0.5563
-0.400	0.5918	0.5362	0.4589	0.2468	-0.6217
-0.600	0.5901	0.5295	0.4540	0.2693	-0.5939
-0.700	0.5714	0.5143	0.4483	0.2855	-0.5537
-0.800	0.5172	*****	0.4315	0.2959	-0.4598
-0.850	*****	0.4548	0.4128	0.2880	-0.4509
-0.900	*****	0.3688	0.3588	0.2682	-0.3912
-0.950	0.1190	0.1596	0.1922	0.1613	-0.1410
-0.975	*****	-0.1242	-0.0333	-0.0243	-0.1213
-1.000	-1.4644	-1.4798	-0.7380	-0.8470	-0.5049

Surface Pressures



Medium Radius L.E.
 Run No. = 24, Point No. = 501
 $C_N = 1.106$, $C_m = -0.1560$
 $\alpha = 24.6^\circ$, $M_\infty = 0.800$
 $R_{mac} = 59.6 \times 10^6$

Leading Edge Pressures

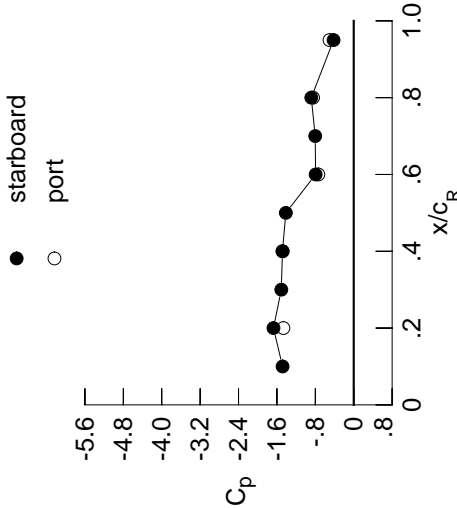

x/c_R	starb'd C_p	port C_p
0.10	-1.4828	*****
0.20	-1.6723	-1.4644
0.30	-1.5091	*****
0.40	-1.4848	-1.4798
0.50	-1.4144	*****
0.60	-0.7939	-0.7380
0.70	-0.8027	*****
0.80	-0.8844	-0.8470
0.90	*****	*****
0.95	-0.4202	-0.5049

Table G1. Concluded.

η	$x/c_R = 0.2$		$x/c_R = 0.4$		$x/c_R = 0.6$		$x/c_R = 0.8$		$x/c_R = 0.95$	
	$C_{p,u}$	$C_{p,u}$	$C_{p,u}$	$C_{p,u}$	$C_{p,u}$	$C_{p,u}$	$C_{p,u}$	$C_{p,u}$	$C_{p,u}$	$C_{p,u}$
0.050	-0.7705	-0.7722	-0.1426	*****	*****	*****	*****	*****	*****	*****
0.100	-0.7672	-0.7824	-0.1556	*****	*****	*****	*****	*****	*****	*****
0.150	-0.7805	-0.7932	-0.1721	*****	*****	*****	*****	*****	*****	*****
0.200	-0.7957	-0.8077	-0.1940	*****	*****	*****	*****	*****	*****	*****
0.250	*****	-0.8515	-0.2449	-1.0616	-0.7665	*****	*****	*****	*****	*****
0.300	-0.8435	-0.9167	-0.3230	-1.0729	-0.8188	*****	*****	*****	*****	*****
0.350	*****	-1.0283	-0.4507	-1.0761	-0.8139	*****	*****	*****	*****	*****
0.400	-1.0986	-1.1917	-0.6429	-1.0580	-0.8039	*****	*****	*****	*****	*****
0.450	-1.3708	-1.4020	-0.8762	-1.0161	-0.7707	*****	*****	*****	*****	*****
0.500	-1.6656	-1.5852	-1.1736	-0.9637	-0.7405	*****	*****	*****	*****	*****
0.525	*****	-1.6802	-1.3051	-0.9673	-0.7222	*****	*****	*****	*****	*****
0.550	-1.8861	-1.7888	-1.4215	-0.9772	-0.7785	*****	*****	*****	*****	*****
0.575	*****	-1.8583	-1.5153	-1.0204	-0.8124	*****	*****	*****	*****	*****
0.600	-2.0145	-1.9208	-1.5226	-1.0662	-0.8101	*****	*****	*****	*****	*****
0.625	*****	*****	-1.3096	-1.0770	-0.7986	*****	*****	*****	*****	*****
0.650	-1.8576	-1.7329	-1.2028	-1.0776	-0.7777	*****	*****	*****	*****	*****
0.675	*****	-1.6505	-1.1650	-1.0817	-0.7492	*****	*****	*****	*****	*****
0.700	-1.8882	-1.6482	-1.1467	-1.0676	-0.7343	*****	*****	*****	*****	*****
0.725	*****	-1.6464	*****	-1.0548	-0.7126	*****	*****	*****	*****	*****
0.750	-1.9537	-1.6486	*****	-1.0264	-0.6856	*****	*****	*****	*****	*****
0.775	*****	-1.6694	-1.0301	-1.0225	-0.6653	*****	*****	*****	*****	*****
0.800	-1.6467	-1.6967	-1.0110	-1.0194	*****	*****	*****	*****	*****	*****
0.825	*****	-1.6669	-1.0127	-0.9968	-0.6312	*****	*****	*****	*****	*****
0.850	-1.5869	-1.6121	-0.9874	-0.9971	-0.5920	*****	*****	*****	*****	*****
0.875	*****	-1.5674	-0.9633	-0.9820	-0.5743	*****	*****	*****	*****	*****
0.900	-1.5237	-1.5527	-0.9101	-0.9661	-0.5518	*****	*****	*****	*****	*****
0.925	*****	-1.5620	-0.8580	-0.9372	-0.5349	*****	*****	*****	*****	*****
0.950	-1.5158	-1.5601	-0.8306	-0.9211	-0.4963	*****	*****	*****	*****	*****
0.975	*****	-1.5396	-0.8252	-0.8873	-0.4625	*****	*****	*****	*****	*****
1.000	-1.7208	-1.5758	-0.8345	-0.8640	-0.4445	*****	*****	*****	*****	*****
-0.200	$C_{p,l}$	$C_{p,l}$	$C_{p,l}$	$C_{p,l}$	$C_{p,l}$	$C_{p,l}$	$C_{p,l}$	$C_{p,l}$	$C_{p,l}$	$C_{p,l}$
-0.400	0.6372	0.5591	0.5018	*****	-0.5308	*****	*****	*****	*****	*****
-0.600	0.6449	0.5630	0.4786	0.2597	-0.6059	*****	*****	*****	*****	*****
-0.700	0.6359	0.5528	0.4683	0.2844	-0.5837	*****	*****	*****	*****	*****
-0.800	0.6099	0.5530	0.4668	0.2938	-0.5439	*****	*****	*****	*****	*****
-0.850	0.5394	*****	0.4575	0.3050	-0.4529	*****	*****	*****	*****	*****
-0.900	*****	0.4727	0.4316	0.3100	-0.4225	*****	*****	*****	*****	*****
-0.950	*****	0.3697	0.3634	0.2799	-0.3609	*****	*****	*****	*****	*****
-0.975	0.0908	0.1364	0.1699	0.1460	-0.1298	*****	*****	*****	*****	*****
-1.000	*****	-0.1695	-0.0791	-0.0633	-0.1331	*****	*****	*****	*****	*****
-1.000	-1.5793	-1.5637	-0.8519	-0.8430	-0.4972	*****	*****	*****	*****	*****

Medium Radius L.E.
 Run No. = 24 , Point No. = 502
 $C_N = 1.221$, $C_m = -0.1733$
 $\alpha = 26.7^\circ$, $M_\infty = 0.797$
 $R_{mac} = 59.3 \times 10^6$

Leading Edge Pressures

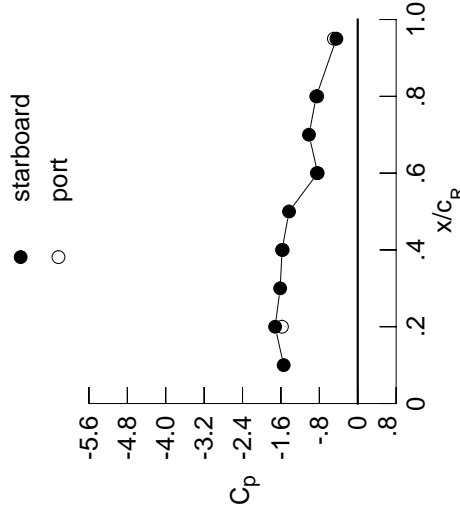

x/c_R	starb'd C_p	port C_p
0.10	-1.5428	*****
0.20	-1.7208	-1.5793
0.30	-1.6157	*****
0.40	-1.5758	-1.5637
0.50	-1.4312	*****
0.60	-0.8345	-0.8519
0.70	-1.0156	*****
0.80	-0.8640	-0.8430
0.90	*****	*****
0.95	-0.4445	-0.4972

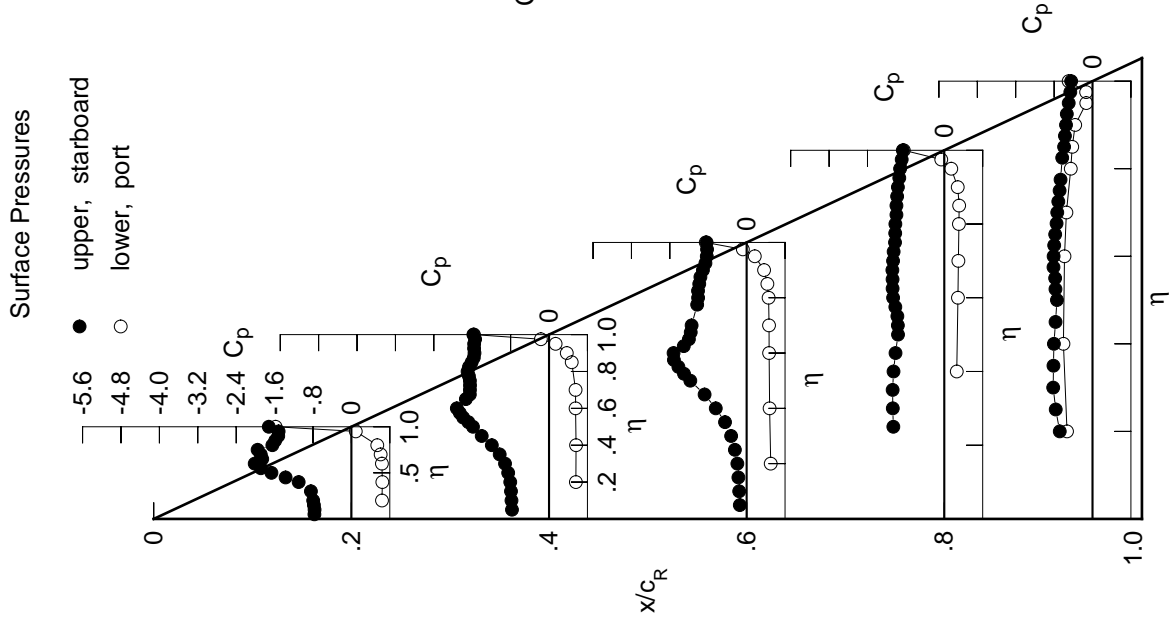
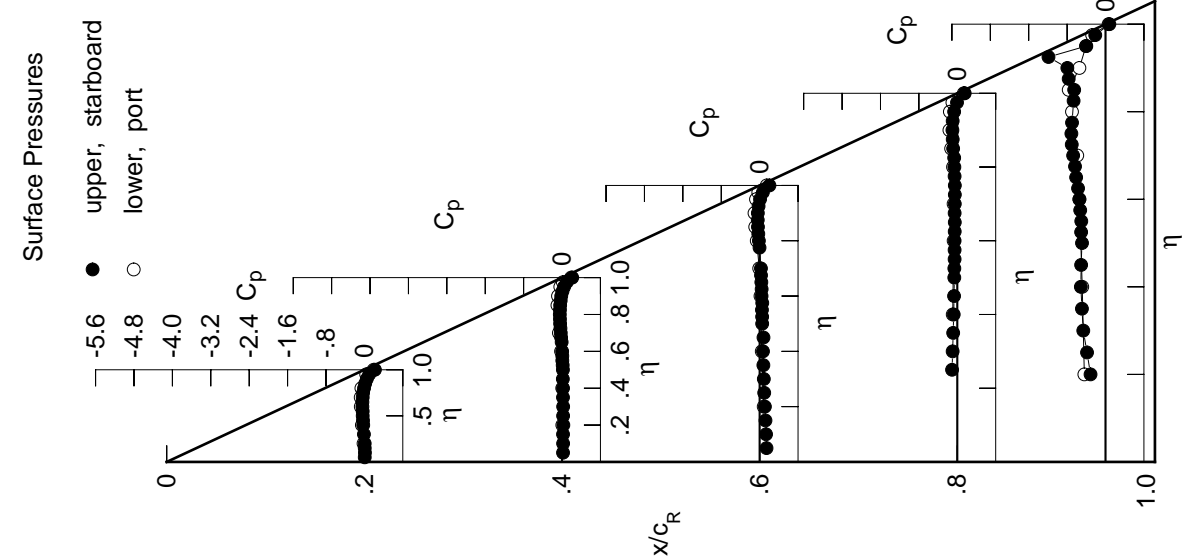

Table G2. Tabulations and Plots of Surface Pressure Coefficients.

η	$x/c_R = .2$		$x/c_R = .4$		$x/c_R = .6$		$x/c_R = .8$		$x/c_R = .95$	
	$C_{p,u}$	$C_{p,u}$	$C_{p,u}$	$C_{p,u}$	$C_{p,u}$	$C_{p,u}$	$C_{p,u}$	$C_{p,u}$	$C_{p,u}$	$C_{p,u}$
0.050	0.0071	0.0207	0.1435	0.1435	0.1435	0.1435	0.1435	0.1435	0.1435	0.1435
0.100	0.0115	0.0221	0.1338	0.1338	0.1338	0.1338	0.1338	0.1338	0.1338	0.1338
0.150	0.0070	0.0210	0.1213	0.1213	0.1213	0.1213	0.1213	0.1213	0.1213	0.1213
0.200	0.0066	0.0276	0.1093	0.1093	0.1093	0.1093	0.1093	0.1093	0.1093	0.1093
0.250	0.0066	0.0222	0.0956	0.0956	0.0956	0.0956	0.0956	0.0956	0.0956	0.0956
0.300	-0.0092	0.0232	0.0870	0.0870	0.0870	0.0870	0.0870	0.0870	0.0870	0.0870
0.350	0.0066	0.0203	0.0777	0.0777	0.0777	0.0777	0.0777	0.0777	0.0777	0.0777
0.400	-0.0242	0.0210	0.0696	0.0696	0.0696	0.0696	0.0696	0.0696	0.0696	0.0696
0.450	-0.0291	0.0168	0.0797	0.0797	0.0797	0.0797	0.0797	0.0797	0.0797	0.0797
0.500	-0.0348	0.0183	0.0529	0.0529	0.0529	0.0529	0.0529	0.0529	0.0529	0.0529
0.525	0.0066	0.0134	0.0524	0.0524	0.0524	0.0524	0.0524	0.0524	0.0524	0.0524
0.550	-0.0348	0.0055	0.0481	0.0481	0.0481	0.0481	0.0481	0.0481	0.0481	0.0481
0.575	0.0066	0.0058	0.0545	0.0545	0.0545	0.0545	0.0545	0.0545	0.0545	0.0545
0.600	-0.0416	0.0025	0.0398	0.0398	0.0398	0.0398	0.0398	0.0398	0.0398	0.0398
0.625	0.0066	0.0000	0.0413	0.0413	0.0413	0.0413	0.0413	0.0413	0.0413	0.0413
0.650	-0.0405	-0.0081	0.0349	0.0349	0.0349	0.0349	0.0349	0.0349	0.0349	0.0349
0.675	0.0066	-0.0188	0.0287	0.0287	0.0287	0.0287	0.0287	0.0287	0.0287	0.0287
0.700	-0.0351	-0.0266	0.0275	0.0275	0.0275	0.0275	0.0275	0.0275	0.0275	0.0275
0.725	0.0066	-0.0328	0.0000	0.0000	0.0000	0.0000	0.0000	0.0000	0.0000	0.0000
0.750	-0.0270	-0.0402	0.0000	0.0000	0.0000	0.0000	0.0000	0.0000	0.0000	0.0000
0.775	0.0066	-0.0429	-0.0028	-0.0028	-0.0028	-0.0028	-0.0028	-0.0028	-0.0028	-0.0028
0.800	-0.0072	-0.0462	-0.0161	-0.0161	-0.0161	-0.0161	-0.0161	-0.0161	-0.0161	-0.0161
0.825	0.0066	-0.0432	-0.0280	-0.0280	-0.0280	-0.0280	-0.0280	-0.0280	-0.0280	-0.0280
0.850	0.0156	-0.0395	-0.0351	-0.0351	-0.0351	-0.0351	-0.0351	-0.0351	-0.0351	-0.0351
0.875	0.0066	-0.0284	-0.0392	-0.0392	-0.0392	-0.0392	-0.0392	-0.0392	-0.0392	-0.0392
0.900	0.0500	-0.0166	-0.0375	-0.0375	-0.0375	-0.0375	-0.0375	-0.0375	-0.0375	-0.0375
0.925	0.0066	0.0079	-0.0228	-0.0228	-0.0228	-0.0228	-0.0228	-0.0228	-0.0228	-0.0228
0.950	0.1003	0.0429	0.0087	0.0087	0.0087	0.0087	0.0087	0.0087	0.0087	0.0087
0.975	0.0066	0.0978	0.0669	0.0669	0.0669	0.0669	0.0669	0.0669	0.0669	0.0669
1.000	0.2194	0.2116	0.2037	0.2037	0.2037	0.2037	0.2037	0.2037	0.2037	0.2037
	$C_{p,l}$	$C_{p,l}$	$C_{p,l}$	$C_{p,l}$	$C_{p,l}$	$C_{p,l}$	$C_{p,l}$	$C_{p,l}$	$C_{p,l}$	$C_{p,l}$
-0.200	-0.0177	0.0057	0.0844	0.0844	0.0844	0.0844	0.0844	0.0844	0.0844	0.0844
-0.400	-0.0518	0.0041	0.0443	0.0443	0.0443	0.0443	0.0443	0.0443	0.0443	0.0443
-0.600	-0.0749	-0.0204	0.0173	0.0173	0.0173	0.0173	0.0173	0.0173	0.0173	0.0173
-0.700	-0.0766	-0.0644	-0.0091	-0.0091	-0.0091	-0.0091	-0.0091	-0.0091	-0.0091	-0.0091
-0.800	-0.0627	0.0000	-0.0603	-0.0603	-0.0603	-0.0603	-0.0603	-0.0603	-0.0603	-0.0603
-0.850	0.0066	-0.0961	-0.0918	-0.0918	-0.0918	-0.0918	-0.0918	-0.0918	-0.0918	-0.0918
-0.900	0.0066	-0.0836	-0.1074	-0.1074	-0.1074	-0.1074	-0.1074	-0.1074	-0.1074	-0.1074
-0.950	0.0379	-0.0359	-0.0757	-0.0757	-0.0757	-0.0757	-0.0757	-0.0757	-0.0757	-0.0757
-0.975	0.0066	0.0173	-0.0278	-0.0278	-0.0278	-0.0278	-0.0278	-0.0278	-0.0278	-0.0278
-1.000	0.1932	0.1903	0.1476	0.1476	0.1476	0.1476	0.1476	0.1476	0.1476	0.1476

Medium Radius L.E.
 Run No. = 25 , Point No. = 503
 $C_N = -0.021$, $C_m = -0.0010$
 $\alpha = -0.7^\circ$, $M_\infty = 0.831$
 $R_{mac} = 59.9 \times 10^6$



Leading Edge Pressures

● starboard
 ○ port

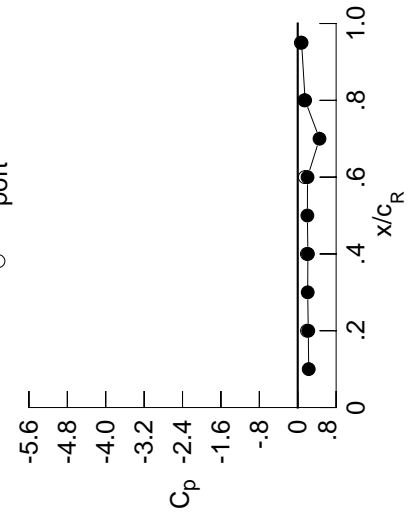

x/c_R	starb'd C_p	port C_p
0.10	0.2287	0.1932
0.20	0.2194	0.1903
0.30	0.2076	0.1903
0.40	0.2116	0.1903
0.50	0.2011	0.1903
0.60	0.2037	0.1476
0.70	0.4535	0.1476
0.80	0.1540	0.1353
0.90	0.0802	0.0648
0.95	0.0802	0.0648

Table G2. Continued.

η	$x/c_R = .2$		$x/c_R = .4$		$x/c_R = .6$		$x/c_R = .8$		$x/c_R = .95$	
	$C_{p,u}$	$C_{p,u}$	$C_{p,u}$	$C_{p,u}$	$C_{p,u}$	$C_{p,u}$	$C_{p,u}$	$C_{p,u}$	$C_{p,u}$	$C_{p,u}$
0.050	-0.0066	0.0082	0.1302	*****	*****	*****	*****	*****	*****	
0.100	-0.0027	0.0084	0.1218	*****	*****	*****	*****	*****	*****	
0.150	-0.0073	0.0088	0.1096	*****	*****	*****	*****	*****	*****	
0.200	-0.0079	0.0127	0.0967	*****	*****	*****	*****	*****	-0.3108	
0.250	*****	0.0090	0.0837	-0.1217	-0.3851	*****	*****	*****	*****	
0.300	-0.0147	0.0090	0.0745	-0.1076	-0.4661	*****	*****	*****	*****	
0.350	*****	0.0060	0.0640	-0.0983	-0.4971	*****	*****	*****	*****	
0.400	-0.0311	0.0061	0.0574	-0.0852	-0.5206	*****	*****	*****	*****	
0.450	-0.0364	0.0026	0.0675	-0.0794	-0.5158	*****	*****	*****	*****	
0.500	-0.0429	0.0028	0.0402	-0.0737	-0.4965	*****	*****	*****	*****	
0.525	*****	-0.0013	0.0398	-0.0731	-0.5150	*****	*****	*****	*****	
0.550	-0.0434	-0.0087	0.0362	-0.0684	-0.5117	*****	*****	*****	*****	
0.575	*****	-0.0094	0.0402	-0.0685	-0.5346	*****	*****	*****	*****	
0.600	-0.0507	-0.0134	0.0259	-0.0681	-0.5485	*****	*****	*****	*****	
0.625	*****	*****	0.0281	-0.0654	-0.5770	*****	*****	*****	*****	
0.650	-0.0501	-0.0164	0.0214	-0.0643	-0.6142	*****	*****	*****	*****	
0.675	*****	-0.0271	0.0143	-0.0670	-0.6334	*****	*****	*****	*****	
0.700	-0.0458	-0.0355	0.0127	-0.0649	-0.6612	*****	*****	*****	*****	
0.725	*****	-0.0422	*****	-0.0638	-0.6796	*****	*****	*****	*****	
0.750	-0.0385	-0.0503	*****	-0.0649	-0.6674	*****	*****	*****	*****	
0.775	*****	-0.0542	-0.0114	-0.0706	-0.6171	*****	*****	*****	*****	
0.800	-0.0193	-0.0583	-0.0258	-0.0765	*****	*****	*****	*****	*****	
0.825	*****	-0.0557	-0.0385	-0.0734	-0.5857	*****	*****	*****	*****	
0.850	0.0026	-0.0533	-0.0470	-0.0953	-0.6003	*****	*****	*****	*****	
0.875	*****	-0.0432	-0.0532	-0.1067	-0.7704	*****	*****	*****	*****	
0.900	0.0360	-0.0325	-0.0532	-0.1159	-0.7978	*****	*****	*****	*****	
0.925	*****	-0.0094	-0.0401	-0.1122	-1.1894	*****	*****	*****	*****	
0.950	0.0862	0.0254	-0.0107	-0.0839	-0.4079	*****	*****	*****	*****	
0.975	*****	0.0788	0.0454	-0.0263	-0.2275	*****	*****	*****	*****	
1.000	0.2225	0.2172	0.2195	0.1643	0.0874	*****	*****	*****	*****	
η	$C_{p,l}$	$C_{p,l}$	$C_{p,l}$	$C_{p,l}$	$C_{p,l}$	$C_{p,l}$	$C_{p,l}$	$C_{p,l}$	$C_{p,l}$	
-0.200	-0.0187	0.0041	0.0825	*****	*****	-0.4559	*****	*****	*****	
-0.400	-0.0437	0.0031	0.0427	-0.0973	-0.4925	*****	*****	*****	*****	
-0.600	-0.0643	-0.0199	0.0166	-0.0782	-0.5641	*****	*****	*****	*****	
-0.700	-0.0642	-0.0538	-0.0081	-0.0776	-0.6249	*****	*****	*****	*****	
-0.800	-0.0483	*****	-0.0488	-0.0687	-0.7122	*****	*****	*****	*****	
-0.850	*****	-0.0798	-0.0774	-0.1160	-0.7699	*****	*****	*****	*****	
-0.900	*****	-0.0641	-0.0893	-0.1474	-0.5817	*****	*****	*****	*****	
-0.950	0.0555	-0.0140	-0.0524	-0.1309	-0.3935	*****	*****	*****	*****	
-0.975	*****	0.0420	-0.0014	-0.0749	-0.2577	*****	*****	*****	*****	
-1.000	0.1984	0.1991	0.1613	0.1537	0.0764	*****	*****	*****	*****	

Medium Radius L.E.
 Run No. = 25 , Point No. = 504
 $C_N = -0.008$, $C_m = -0.0025$
 $\alpha = -0.4^\circ$, $M_\infty = 0.833$
 $R_{mac} = 59.9 \times 10^6$

Leading Edge Pressures

● starboard
 ○ port

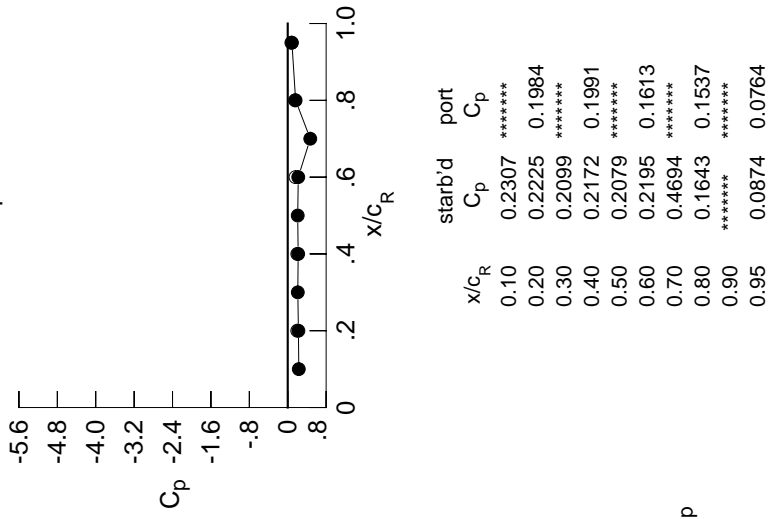

Surface Pressures
 ● upper, starboard
 ○ lower, port

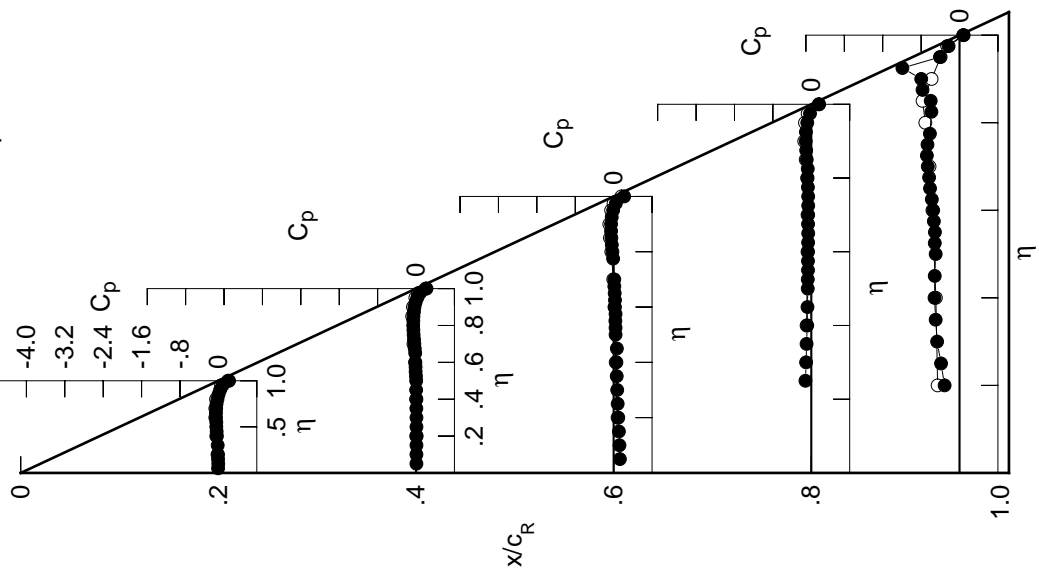

Table G2. Continued.

η	$x/c_R = .2$		$x/c_R = .4$		$x/c_R = .6$		$x/c_R = .8$		$x/c_R = .95$	
	$C_{p,u}$	$C_{p,l}$	$C_{p,u}$	$C_{p,l}$	$C_{p,u}$	$C_{p,l}$	$C_{p,u}$	$C_{p,l}$	$C_{p,u}$	$C_{p,l}$
0.050	-0.0277	-0.0104	0.1185	*****	*****	*****	*****	*****	*****	*****
0.100	-0.0238	-0.0105	0.1084	*****	*****	*****	*****	*****	*****	*****
0.150	-0.0283	-0.0110	0.0958	*****	*****	*****	*****	*****	*****	*****
0.200	-0.0299	-0.0059	0.0837	*****	*****	*****	*****	*****	*****	*****
0.250	*****	-0.0102	0.0701	-0.1344	-0.1344	-0.3705	-0.2966	-0.2966	-0.2966	-0.2966
0.300	-0.0349	-0.0104	0.0593	-0.1204	-0.1204	-0.4510	-0.3705	-0.3705	-0.3705	-0.3705
0.350	*****	-0.0135	0.0494	-0.1120	-0.1120	-0.4851	-0.4510	-0.4510	-0.4510	-0.4510
0.400	-0.0539	-0.0152	0.0415	-0.0987	-0.0987	-0.5060	-0.4851	-0.4851	-0.4851	-0.4851
0.450	-0.0601	-0.0190	0.0504	-0.0938	-0.0938	-0.4970	-0.5060	-0.5060	-0.5060	-0.5060
0.500	-0.0684	-0.0197	0.0227	-0.0883	-0.0883	-0.4697	-0.4970	-0.4970	-0.4970	-0.4970
0.525	*****	-0.0247	0.0211	-0.0878	-0.0878	-0.4874	-0.4697	-0.4697	-0.4697	-0.4697
0.550	-0.0709	-0.0328	0.0164	-0.0833	-0.0833	-0.4814	-0.4874	-0.4874	-0.4874	-0.4874
0.575	*****	-0.0351	0.0213	-0.0842	-0.0842	-0.5045	-0.4814	-0.4814	-0.4814	-0.4814
0.600	-0.0800	-0.0388	0.0063	-0.0849	-0.0849	-0.5146	-0.5045	-0.5045	-0.5045	-0.5045
0.625	*****	*****	0.0065	-0.0831	-0.0831	-0.5403	-0.5146	-0.5146	-0.5146	-0.5146
0.650	-0.0823	-0.0417	-0.0001	-0.0823	-0.0823	-0.5688	-0.5403	-0.5403	-0.5403	-0.5403
0.675	*****	-0.0542	-0.0084	-0.0854	-0.0854	-0.5660	-0.5688	-0.5688	-0.5688	-0.5688
0.700	-0.0809	-0.0651	-0.0116	-0.0842	-0.0842	-0.5597	-0.5660	-0.5660	-0.5660	-0.5660
0.725	*****	-0.0731	*****	-0.0846	-0.0846	-0.5308	-0.5597	-0.5597	-0.5597	-0.5597
0.750	-0.0757	-0.0849	*****	-0.0858	-0.0858	-0.4594	-0.5308	-0.5308	-0.5308	-0.5308
0.775	*****	-0.0895	-0.0396	-0.0944	-0.0944	-0.3696	-0.4594	-0.4594	-0.4594	-0.4594
0.800	-0.0589	-0.0986	-0.0574	-0.1035	-0.1035	*****	-0.3696	-0.3696	-0.3696	-0.3696
0.825	*****	-0.0995	-0.0741	-0.0999	-0.4026	*****	-0.1035	-0.1035	-0.1035	-0.1035
0.850	-0.0396	-0.0993	-0.0883	-0.1271	-0.4481	*****	-0.4026	-0.4026	-0.4026	-0.4026
0.875	*****	-0.0935	-0.0999	-0.1452	-0.7309	*****	-0.4481	-0.4481	-0.4481	-0.4481
0.900	-0.0093	-0.0856	-0.1062	-0.1618	-0.8040	*****	-0.7309	-0.7309	-0.7309	-0.7309
0.925	*****	-0.0686	-0.0991	-0.1672	-1.2065	*****	-0.8040	-0.8040	-0.8040	-0.8040
0.950	0.0373	-0.0362	-0.0768	-0.1480	-0.4450	*****	-1.2065	-1.2065	-1.2065	-1.2065
0.975	*****	0.0120	-0.0264	-0.1003	-0.2829	*****	-0.4450	-0.4450	-0.4450	-0.4450
1.000	0.2161	0.2070	0.2102	0.1512	0.0793	*****	-0.2829	-0.2829	-0.2829	-0.2829
-0.200	$C_{p,l}$	0.0016	0.0217	0.0945	*****	-0.4727	0.0793	0.0793	0.0793	0.0793
-0.400	0.0205	0.0211	0.0564	-0.0867	-0.5136	*****	0.0793	0.0793	0.0793	0.0793
-0.600	-0.0347	0.0018	0.0333	-0.0646	-0.5970	*****	0.0793	0.0793	0.0793	0.0793
-0.700	-0.0304	-0.0243	0.0131	-0.0613	-0.6626	*****	0.0793	0.0793	0.0793	0.0793
-0.800	-0.0086	*****	-0.0170	-0.0638	-0.7103	*****	0.0793	0.0793	0.0793	0.0793
-0.850	*****	-0.0349	-0.0371	-0.0835	-0.7516	*****	0.0793	0.0793	0.0793	0.0793
-0.900	*****	-0.0127	-0.0382	-0.1020	-0.7324	*****	0.0793	0.0793	0.0793	0.0793
-0.950	0.1024	0.0438	0.0100	-0.0692	-0.3591	*****	0.0793	0.0793	0.0793	0.0793
-0.975	*****	0.1041	0.0667	-0.0050	-0.2052	*****	0.0793	0.0793	0.0793	0.0793
-1.000	0.1980	0.1973	0.1577	0.1563	0.0803	*****	0.0793	0.0793	0.0793	0.0793

Medium Radius L.E.
 Run No. = 25 , Point No. = 505
 $C_N = 0.033$, $C_m = -0.0095$
 $\alpha = 0.7^\circ$, $M_\infty = 0.832$
 $R_{mac} = 59.9 \times 10^6$

Leading Edge Pressures

● starboard
 ○ port

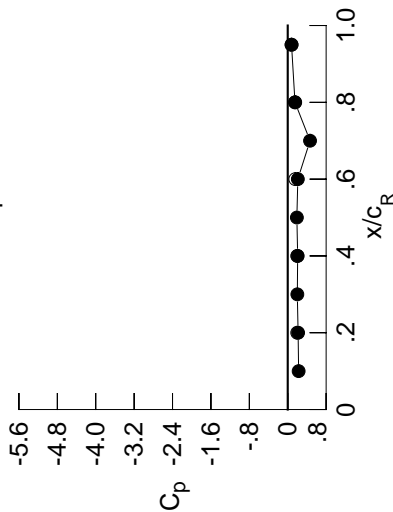

x/c_R	starb'd C_p	port C_p
0.10	0.2270	*****
0.20	0.2161	0.1980
0.30	0.1997	*****
0.40	0.2070	0.1973
0.50	0.1902	*****
0.60	0.2102	0.1577
0.70	0.4649	*****
0.80	0.1512	0.1563
0.90	*****	*****
0.95	0.0793	0.0803

Surface Pressures

● upper, starboard
 ○ lower, port

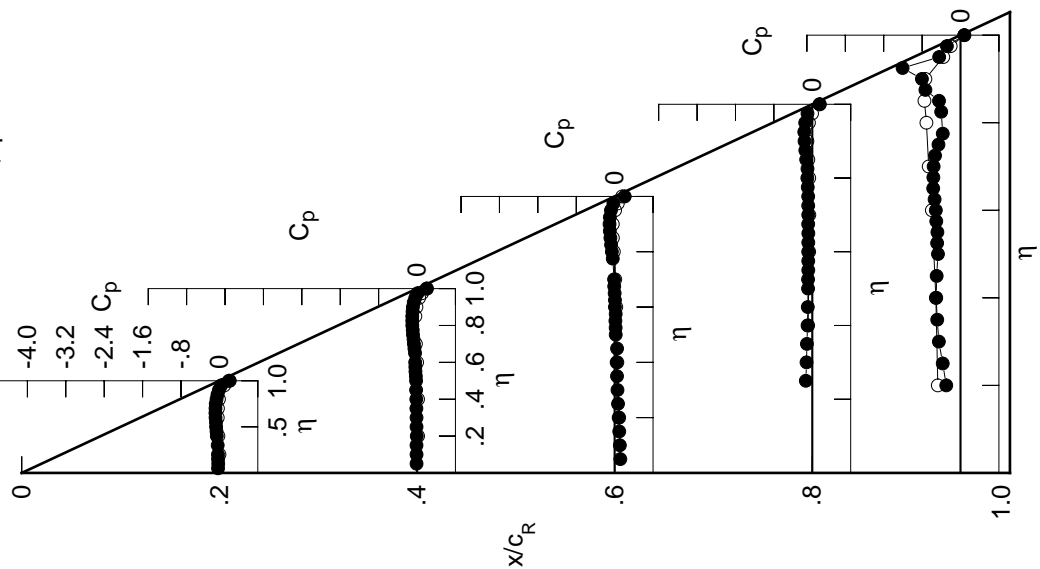

Table G2. Continued.

η	$x/c_R = .2$		$x/c_R = .4$		$x/c_R = .6$		$x/c_R = .8$		$x/c_R = .95$	
	$C_{p,u}$	$C_{p,u}$	$C_{p,u}$	$C_{p,u}$	$C_{p,u}$	$C_{p,u}$	$C_{p,u}$	$C_{p,u}$	$C_{p,u}$	$C_{p,u}$
0.050	-0.0478	-0.0286	0.1047	*****	*****	*****	*****	*****	*****	*****
0.100	-0.0444	-0.0281	0.0953	*****	*****	*****	*****	*****	*****	*****
0.150	-0.0488	-0.0291	0.0825	*****	*****	*****	*****	*****	*****	*****
0.200	-0.0506	-0.0248	0.0696	*****	*****	*****	*****	*****	*****	-0.2804
0.250	*****	-0.0294	0.0558	-0.1468	-0.1468	-0.1468	-0.1468	-0.1468	-0.1468	-0.3476
0.300	-0.0557	-0.0290	0.0450	-0.1326	-0.1326	-0.1326	-0.1326	-0.1326	-0.1326	-0.4248
0.350	*****	-0.0336	0.0329	-0.1239	-0.1239	-0.1239	-0.1239	-0.1239	-0.1239	-0.4671
0.400	-0.0770	-0.0342	0.0255	-0.1109	-0.1109	-0.1109	-0.1109	-0.1109	-0.1109	-0.5038
0.450	-0.0856	-0.0400	0.0325	-0.1072	-0.1072	-0.1072	-0.1072	-0.1072	-0.1072	-0.5003
0.500	-0.0948	-0.0416	0.0055	-0.1025	-0.1025	-0.1025	-0.1025	-0.1025	-0.1025	-0.4765
0.525	*****	-0.0473	0.0031	-0.1028	-0.1028	-0.1028	-0.1028	-0.1028	-0.1028	-0.4949
0.550	-0.0994	-0.0564	-0.0024	-0.0983	-0.0983	-0.0983	-0.0983	-0.0983	-0.0983	-0.4879
0.575	*****	-0.0590	0.0018	-0.1004	-0.1004	-0.1004	-0.1004	-0.1004	-0.1004	-0.5107
0.600	-0.1110	-0.0645	-0.0134	-0.1002	-0.1002	-0.1002	-0.1002	-0.1002	-0.1002	-0.5181
0.625	*****	*****	-0.0156	-0.0992	-0.0992	-0.0992	-0.0992	-0.0992	-0.0992	-0.5346
0.650	-0.1163	-0.0687	-0.0214	-0.0992	-0.0992	-0.0992	-0.0992	-0.0992	-0.0992	-0.5492
0.675	*****	-0.0830	-0.0322	-0.1040	-0.1040	-0.1040	-0.1040	-0.1040	-0.1040	-0.5262
0.700	-0.1175	-0.0957	-0.0354	-0.1037	-0.1037	-0.1037	-0.1037	-0.1037	-0.1037	-0.4952
0.725	*****	-0.1076	*****	-0.1056	-0.1056	-0.1056	-0.1056	-0.1056	-0.1056	-0.4413
0.750	-0.1154	-0.1203	*****	-0.1087	-0.1087	-0.1087	-0.1087	-0.1087	-0.1087	-0.3646
0.775	*****	-0.1306	-0.0708	-0.1192	-0.1192	-0.1192	-0.1192	-0.1192	-0.1192	-0.2783
0.800	-0.1022	-0.1412	-0.0924	-0.1309	-0.1309	-0.1309	-0.1309	-0.1309	-0.1309	*****
0.825	*****	-0.1474	-0.1130	-0.1278	-0.1278	-0.1278	-0.1278	-0.1278	-0.1278	-0.3154
0.850	-0.0865	-0.1518	-0.1329	-0.1623	-0.1623	-0.1623	-0.1623	-0.1623	-0.1623	-0.3449
0.875	*****	-0.1511	-0.1513	-0.1873	-0.1873	-0.1873	-0.1873	-0.1873	-0.1873	-0.5703
0.900	-0.0611	-0.1476	-0.1654	-0.2137	-0.2137	-0.2137	-0.2137	-0.2137	-0.2137	-0.7633
0.925	*****	-0.1355	-0.1668	-0.2288	-0.2288	-0.2288	-0.2288	-0.2288	-0.2288	-1.2183
0.950	-0.0199	-0.1099	-0.1545	-0.2229	-0.2229	-0.2229	-0.2229	-0.2229	-0.2229	-0.4881
0.975	*****	-0.0744	-0.1172	-0.1913	-0.1913	-0.1913	-0.1913	-0.1913	-0.1913	-0.3507
1.000	0.1811	0.1434	0.1232	0.0588	0.0588	0.0588	0.0588	0.0588	0.0588	0.0175
	$C_{p,l}$	$C_{p,l}$	$C_{p,l}$	$C_{p,l}$	$C_{p,l}$	$C_{p,l}$	$C_{p,l}$	$C_{p,l}$	$C_{p,l}$	$C_{p,l}$
-0.200	0.0220	0.0393	0.1074	*****	*****	*****	*****	*****	*****	-0.4938
-0.400	0.0033	0.0403	0.0705	-0.0743	-0.0743	-0.0743	-0.0743	-0.0743	-0.0743	-0.5497
-0.600	-0.0043	0.0256	0.0514	-0.0499	-0.0499	-0.0499	-0.0499	-0.0499	-0.0499	-0.6262
-0.700	0.0043	0.0059	0.0347	-0.0437	-0.0437	-0.0437	-0.0437	-0.0437	-0.0437	-0.6949
-0.800	0.0303	*****	0.0142	-0.0403	-0.0403	-0.0403	-0.0403	-0.0403	-0.0403	-0.6988
-0.850	*****	0.0093	0.0023	-0.0519	-0.0519	-0.0519	-0.0519	-0.0519	-0.0519	-0.7282
-0.900	*****	0.0365	0.0093	-0.0587	-0.0587	-0.0587	-0.0587	-0.0587	-0.0587	-0.7787
-0.950	0.1438	0.0957	0.0652	-0.0131	-0.0131	-0.0131	-0.0131	-0.0131	-0.0131	-0.3281
-0.975	*****	0.1549	0.1221	0.0532	0.0532	0.0532	0.0532	0.0532	0.0532	-0.1601
-1.000	0.1656	0.1439	0.0816	0.0818	0.0818	0.0818	0.0818	0.0818	0.0818	0.0316

Medium Radius L.E.
 Run No. = 25 , Point No. = 506
 $C_N = 0.070$, $C_m = -0.0119$
 $\alpha = 1.8^\circ$, $M_\infty = 0.831$
 $R_{mac} = 59.9 \times 10^6$

Leading Edge Pressures

- starboard
- port

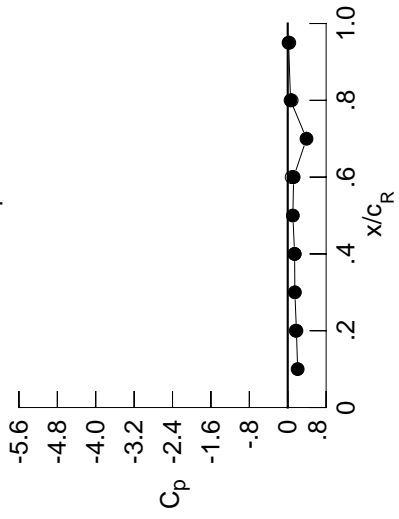

x/c_R	starb'd C_p	port C_p
0.10	0.2064	*****
0.20	0.1811	0.1656
0.30	0.1487	*****
0.40	0.1434	0.1439
0.50	0.1068	*****
0.60	0.1232	0.0816
0.70	0.3910	*****
0.80	0.0588	0.0818
0.90	*****	*****
0.95	0.0175	0.0316

Surface Pressures

- upper, starboard
- lower, port

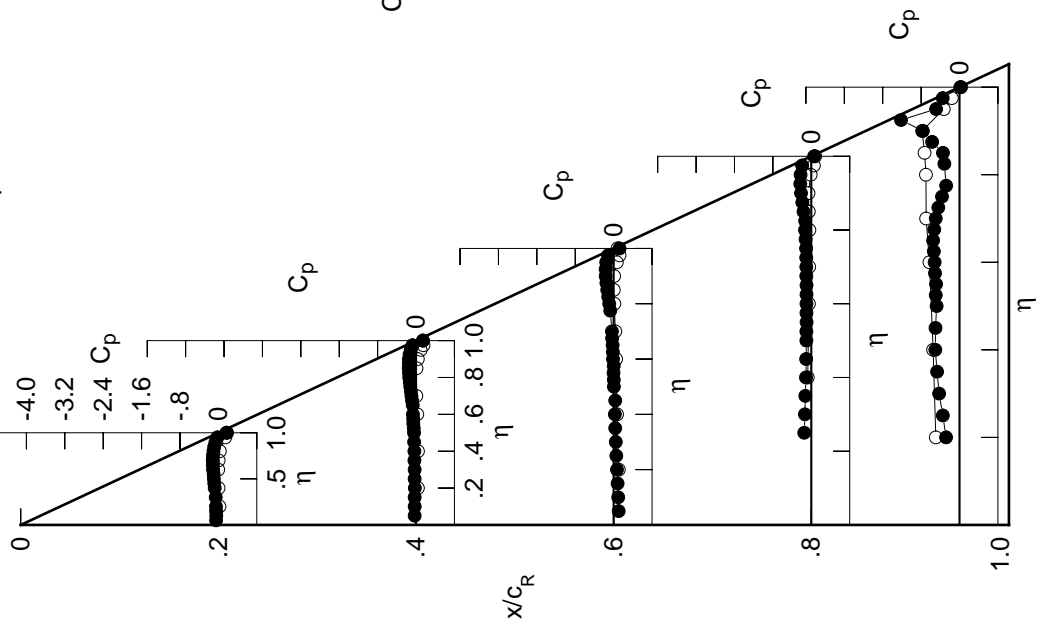

Table G2. Continued.

η	$x/c_R = .2$		$x/c_R = .4$		$x/c_R = .6$		$x/c_R = .8$		$x/c_R = .95$	
	$C_{p,u}$	$C_{p,l}$	$C_{p,u}$	$C_{p,l}$	$C_{p,u}$	$C_{p,l}$	$C_{p,u}$	$C_{p,l}$	$C_{p,u}$	$C_{p,l}$
0.050	-0.0693	-0.0469	0.0912	*****	0.0912	*****	*****	*****	*****	*****
0.100	-0.0650	-0.0468	0.0812	*****	0.0812	*****	*****	*****	*****	*****
0.150	-0.0700	-0.0467	0.0684	*****	0.0684	*****	*****	*****	*****	*****
0.200	-0.0719	-0.0433	0.0553	*****	0.0553	*****	*****	*****	*****	*****
0.250	*****	-0.0485	0.0408	-0.1602	-0.1602	-0.3346	*****	*****	*****	*****
0.300	-0.0769	-0.0497	0.0291	-0.1464	-0.1464	-0.3969	*****	*****	*****	*****
0.350	*****	-0.0535	0.0179	-0.1377	-0.1377	-0.4373	*****	*****	*****	*****
0.400	-0.1007	-0.0553	0.0083	-0.1258	-0.1258	-0.5074	*****	*****	*****	*****
0.450	-0.1108	-0.0622	0.0149	-0.1222	-0.1222	-0.5570	*****	*****	*****	*****
0.500	-0.1218	-0.0648	-0.0132	-0.1174	-0.1174	-0.5771	*****	*****	*****	*****
0.525	*****	-0.0703	-0.0159	-0.1191	-0.1191	-0.6075	*****	*****	*****	*****
0.550	-0.1295	-0.0808	-0.0219	-0.1161	-0.1161	-0.6088	*****	*****	*****	*****
0.575	*****	-0.0847	-0.0184	-0.1172	-0.1172	-0.6273	*****	*****	*****	*****
0.600	-0.1429	-0.0907	-0.0346	-0.1189	-0.1189	-0.6238	*****	*****	*****	*****
0.625	*****	*****	-0.0369	-0.1171	-0.1171	-0.6080	*****	*****	*****	*****
0.650	-0.1504	-0.0963	-0.0446	-0.1191	-0.1191	-0.5737	*****	*****	*****	*****
0.675	*****	-0.1128	-0.0556	-0.1233	-0.1233	-0.4974	*****	*****	*****	*****
0.700	-0.1556	-0.1273	-0.0616	-0.1255	-0.1255	-0.4287	*****	*****	*****	*****
0.725	*****	-0.1422	*****	-0.1280	-0.1280	-0.3704	*****	*****	*****	*****
0.750	-0.1568	-0.1582	*****	-0.1349	-0.1349	-0.2987	*****	*****	*****	*****
0.775	*****	-0.1709	-0.1024	-0.1459	-0.1459	-0.2138	*****	*****	*****	*****
0.800	-0.1477	-0.1864	-0.1270	-0.1610	-0.1610	*****	*****	*****	*****	*****
0.825	*****	-0.1962	-0.1536	-0.1598	-0.1598	-0.2499	*****	*****	*****	*****
0.850	-0.1369	-0.2055	-0.1809	-0.1989	-0.1989	-0.2755	*****	*****	*****	*****
0.875	*****	-0.2102	-0.2057	-0.2324	-0.2324	-0.4409	*****	*****	*****	*****
0.900	-0.1176	-0.2137	-0.2287	-0.2681	-0.2681	-0.7144	*****	*****	*****	*****
0.925	*****	-0.2076	-0.2392	-0.2964	-0.2964	-1.2311	*****	*****	*****	*****
0.950	-0.0843	-0.1909	-0.2413	-0.3053	-0.3053	-0.5361	*****	*****	*****	*****
0.975	*****	-0.1695	-0.2219	-0.2951	-0.2951	-0.4268	*****	*****	*****	*****
1.000	0.1157	0.0321	-0.0250	-0.1022	-0.1022	*****	*****	*****	*****	*****
	$C_{p,l}$	$C_{p,i}$	$C_{p,l}$	$C_{p,i}$	$C_{p,l}$	$C_{p,i}$	$C_{p,l}$	$C_{p,i}$	$C_{p,l}$	$C_{p,i}$
-0.200	0.0403	0.0546	0.1182	*****	*****	-0.5146	*****	*****	*****	*****
-0.400	0.0253	0.0569	0.0831	-0.0643	-0.6838	*****	*****	*****	*****	*****
-0.600	0.0231	0.0464	0.0656	-0.0377	-0.7407	*****	*****	*****	*****	*****
-0.700	0.0346	0.0315	0.0537	-0.0294	-0.7395	*****	*****	*****	*****	*****
-0.800	0.0638	*****	0.0398	-0.0207	-0.6904	*****	*****	*****	*****	*****
-0.850	*****	0.0462	0.0343	-0.0249	-0.7106	*****	*****	*****	*****	*****
-0.900	*****	0.0764	0.0497	-0.0218	-0.7420	*****	*****	*****	*****	*****
-0.950	0.1753	0.1343	0.1076	0.0320	-0.3029	*****	*****	*****	*****	*****
-0.975	*****	0.1875	0.1588	0.0948	-0.1253	*****	*****	*****	*****	*****
-1.000	0.1037	0.0387	-0.0694	-0.0626	-0.0654	*****	*****	*****	*****	*****

Medium Radius L.E.
 Run No. = 25 , Point No. = 507
 $C_N = 0.113$, $C_m = -0.0208$
 $\alpha = 2.8^\circ$, $M_\infty = 0.831$
 $R_{mac} = 59.9 \times 10^6$

Leading Edge Pressures

● starboard
 ○ port

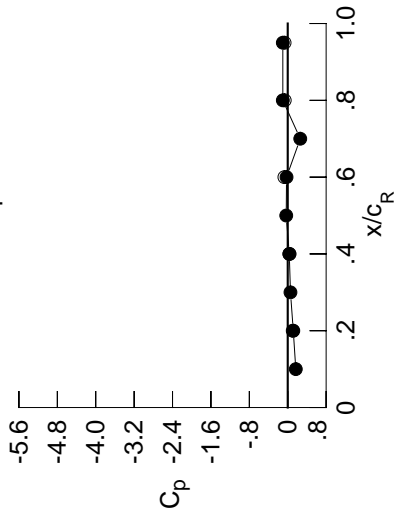

x/c_R	starb'd C_p	port C_p
0.10	0.1680	*****
0.20	0.1157	0.1037
0.30	0.0571	*****
0.40	0.0321	0.0387
0.50	-0.0315	*****
0.60	-0.0250	-0.0694
0.70	0.2612	*****
0.80	-0.1022	-0.0626
0.90	*****	*****
0.95	-0.1022	-0.0654

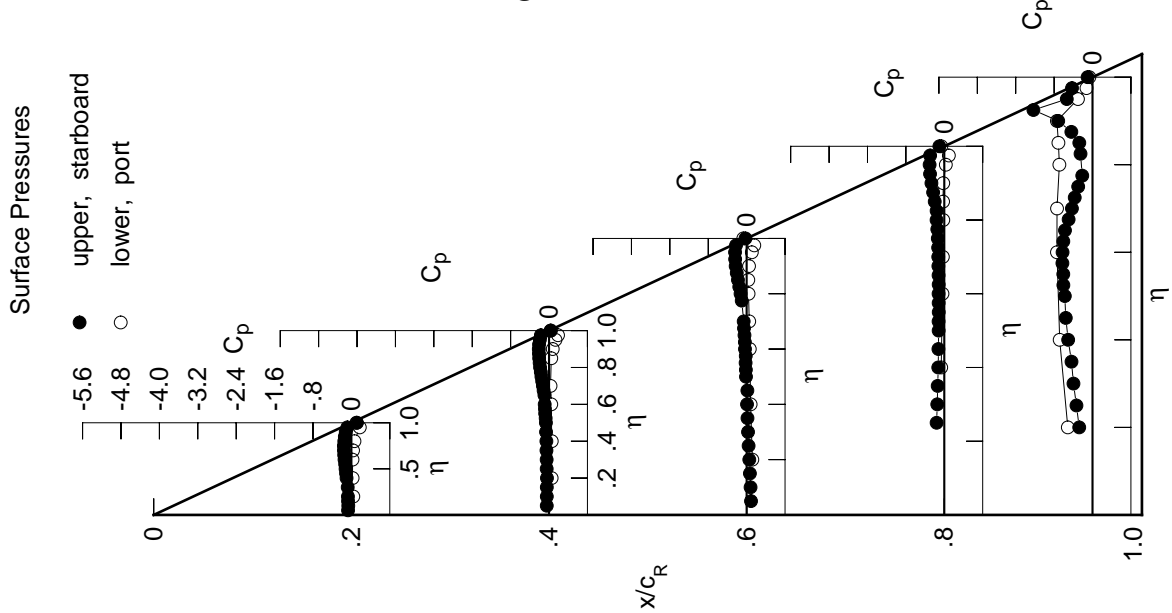

Table G2. Continued.

η	$x/c_R = .2$		$x/c_R = .4$		$x/c_R = .6$		$x/c_R = .8$		$x/c_R = .95$	
	$C_{p,u}$	$C_{p,u}$	$C_{p,u}$	$C_{p,u}$	$C_{p,u}$	$C_{p,u}$	$C_{p,u}$	$C_{p,u}$	$C_{p,u}$	$C_{p,u}$
0.050	-0.0867	-0.0624	0.0805	0.0805	0.0805	0.0805	0.0805	0.0805	0.0805	0.0805
0.100	-0.0841	-0.0629	0.0705	0.0705	0.0705	0.0705	0.0705	0.0705	0.0705	0.0705
0.150	-0.0876	-0.0646	0.0574	0.0574	0.0574	0.0574	0.0574	0.0574	0.0574	0.0574
0.200	-0.0908	-0.0600	0.0438	0.0438	0.0438	0.0438	0.0438	0.0438	0.0438	0.0438
0.250	*****	-0.0655	0.0290	0.0290	-0.1706	-0.1706	-0.3249	-0.3249	-0.3249	-0.3249
0.300	-0.0961	-0.0663	0.0175	-0.1572	-0.1572	-0.3825	-0.3825	-0.3825	-0.3825	-0.3825
0.350	*****	-0.0719	0.0051	-0.1483	-0.1483	-0.4200	-0.4200	-0.4200	-0.4200	-0.4200
0.400	-0.1217	-0.0742	-0.0046	-0.1368	-0.1368	-0.4838	-0.4838	-0.4838	-0.4838	-0.4838
0.450	-0.1333	-0.0820	0.0007	-0.1340	-0.1340	-0.5351	-0.5351	-0.5351	-0.5351	-0.5351
0.500	-0.1465	-0.0853	-0.0282	-0.1302	-0.1302	-0.5604	-0.5604	-0.5604	-0.5604	-0.5604
0.525	*****	-0.0925	-0.0316	-0.1305	-0.1305	-0.5923	-0.5923	-0.5923	-0.5923	-0.5923
0.550	-0.1566	-0.1031	-0.0394	-0.1287	-0.1287	-0.5916	-0.5916	-0.5916	-0.5916	-0.5916
0.575	*****	-0.1077	-0.0349	-0.1310	-0.1310	-0.6052	-0.6052	-0.6052	-0.6052	-0.6052
0.600	-0.1722	-0.1158	-0.0525	-0.1337	-0.1337	-0.5943	-0.5943	-0.5943	-0.5943	-0.5943
0.625	*****	*****	-0.0559	-0.1323	-0.1323	-0.5675	-0.5675	-0.5675	-0.5675	-0.5675
0.650	-0.1843	-0.1220	-0.0645	-0.1355	-0.1355	-0.5260	-0.5260	-0.5260	-0.5260	-0.5260
0.675	*****	-0.1408	-0.0777	-0.1414	-0.1414	-0.4566	-0.4566	-0.4566	-0.4566	-0.4566
0.700	-0.1918	-0.1578	-0.0860	-0.1443	-0.1443	-0.4015	-0.4015	-0.4015	-0.4015	-0.4015
0.725	*****	-0.1746	*****	-0.1489	-0.1489	-0.3477	-0.3477	-0.3477	-0.3477	-0.3477
0.750	-0.1972	-0.1945	*****	-0.1559	-0.1559	-0.2748	-0.2748	-0.2748	-0.2748	-0.2748
0.775	*****	-0.2110	-0.1330	-0.1716	-0.1716	-0.1946	-0.1946	-0.1946	-0.1946	-0.1946
0.800	-0.1930	-0.2315	-0.1612	-0.1889	-0.1889	*****	*****	*****	*****	*****
0.825	*****	-0.2457	-0.1933	-0.1895	-0.1895	-0.2367	-0.2367	-0.2367	-0.2367	-0.2367
0.850	-0.1880	-0.2603	-0.2266	-0.2353	-0.2353	-0.2570	-0.2570	-0.2570	-0.2570	-0.2570
0.875	*****	-0.2714	-0.2609	-0.2759	-0.2759	-0.3898	-0.3898	-0.3898	-0.3898	-0.3898
0.900	-0.1753	-0.2809	-0.2944	-0.3246	-0.3246	-0.6508	-0.6508	-0.6508	-0.6508	-0.6508
0.925	*****	-0.2852	-0.3173	-0.3658	-0.3658	-1.0549	-1.0549	-1.0549	-1.0549	-1.0549
0.950	-0.1530	-0.2784	-0.3347	-0.3933	-0.3933	-0.5878	-0.5878	-0.5878	-0.5878	-0.5878
0.975	*****	-0.2785	-0.3395	-0.4111	-0.4111	-0.5161	-0.5161	-0.5161	-0.5161	-0.5161
1.000	0.0259	-0.1280	-0.2306	-0.3274	-0.3274	-0.2713	-0.2713	-0.2713	-0.2713	-0.2713
-0.200	$C_{p,l}$	$C_{p,l}$	$C_{p,l}$	$C_{p,l}$	$C_{p,l}$	$C_{p,l}$	$C_{p,l}$	$C_{p,l}$	$C_{p,l}$	$C_{p,l}$
-0.400	0.0622	0.0734	0.1329	0.1329	0.1329	0.1329	0.1329	0.1329	0.1329	0.1329
-0.600	0.0501	0.0777	0.1001	0.1001	0.1001	0.1001	0.1001	0.1001	0.1001	0.1001
-0.700	0.0525	0.0688	0.0838	0.0838	0.0838	0.0838	0.0838	0.0838	0.0838	0.0838
-0.800	0.0671	0.0593	0.0762	0.0762	0.0762	0.0762	0.0762	0.0762	0.0762	0.0762
-0.850	0.0988	*****	0.0677	0.0677	0.0677	0.0677	0.0677	0.0677	0.0677	0.0677
-0.900	*****	0.0836	0.0675	0.0675	0.0675	0.0675	0.0675	0.0675	0.0675	0.0675
-0.950	0.2029	0.1687	0.1447	0.1447	0.1447	0.1447	0.1447	0.1447	0.1447	0.1447
-0.975	*****	0.2106	0.1864	0.1864	0.1864	0.1864	0.1864	0.1864	0.1864	0.1864
-1.000	0.0135	-0.1152	-0.2891	-0.2891	-0.2891	-0.2891	-0.2891	-0.2891	-0.2891	-0.2891

Medium Radius L.E.
 Run No. = 25 , Point No. = 508
 $C_N = 0.152$, $C_m = -0.0261$
 $\alpha = 3.9^\circ$, $M_\infty = 0.831$
 $R_{mac} = 59.9 \times 10^6$

Leading Edge Pressures

● starboard
 ○ port

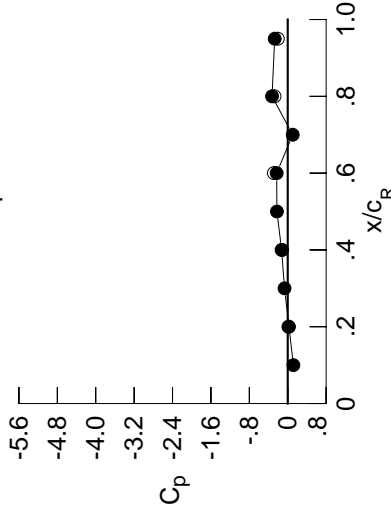

x/c_R	starb'd C_p	port C_p
0.10	0.1176	*****
0.20	0.0259	0.0135
0.30	-0.0670	*****
0.40	-0.1280	-0.1152
0.50	-0.2249	*****
0.60	-0.2306	-0.2891
0.70	0.1039	*****
0.80	-0.3274	-0.2751
0.90	*****	*****
0.95	-0.2713	-0.2068

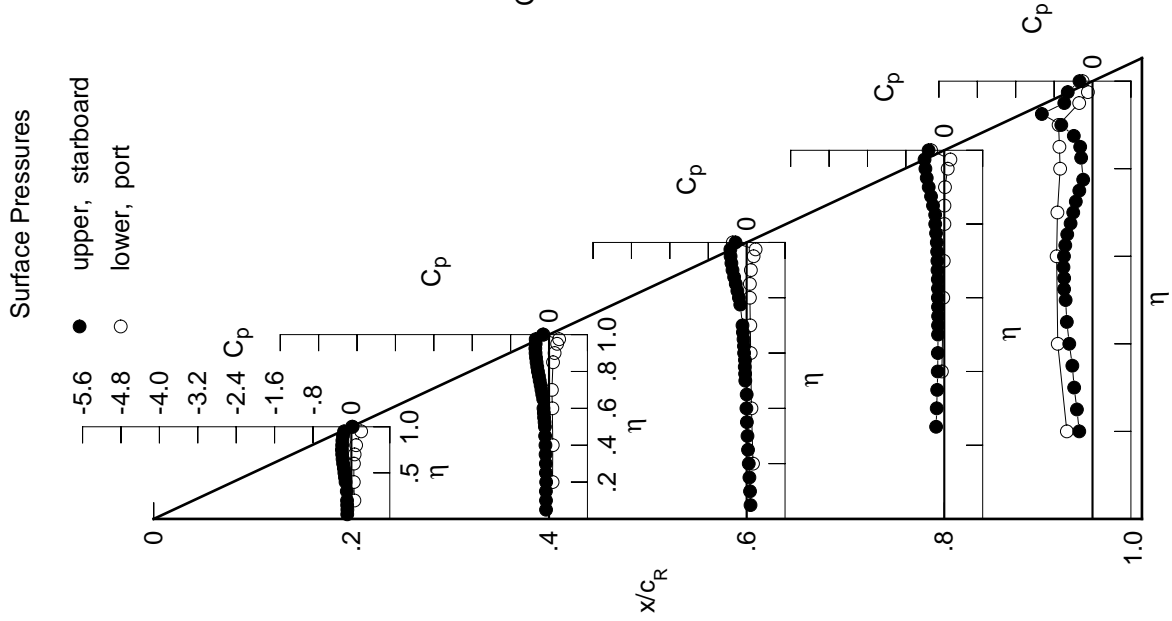

Table G2. Continued.

η	$x/c_R = .2$		$x/c_R = .4$		$x/c_R = .6$		$x/c_R = .8$		$x/c_R = .95$	
	$C_{p,u}$	$C_{p,u}$	$C_{p,u}$	$C_{p,u}$	$C_{p,u}$	$C_{p,u}$	$C_{p,u}$	$C_{p,u}$	$C_{p,u}$	$C_{p,u}$
0.050	-0.1049	-0.0792	0.0691	0.0691	0.0691	0.0691	0.0691	0.0691	0.0691	0.0691
0.100	-0.1022	-0.0790	0.0588	0.0588	0.0588	0.0588	0.0588	0.0588	0.0588	0.0588
0.150	-0.1068	-0.0812	0.0463	0.0463	0.0463	0.0463	0.0463	0.0463	0.0463	0.0463
0.200	-0.1104	-0.0771	0.0316	0.0316	0.0316	0.0316	0.0316	0.0316	0.0316	0.0316
0.250	*****	-0.0826	0.0176	0.0176	0.0176	0.0176	0.0176	0.0176	0.0176	0.0176
0.300	-0.1156	-0.0848	0.0048	0.0048	-0.1671	-0.1671	-0.3625	-0.3625	-0.3625	-0.3625
0.350	*****	-0.0902	-0.0070	-0.1598	-0.1598	-0.3896	-0.3896	-0.3896	-0.3896	-0.3896
0.400	-0.1439	-0.0932	-0.0191	-0.1479	-0.1479	-0.4412	-0.4412	-0.4412	-0.4412	-0.4412
0.450	-0.1570	-0.1023	-0.0142	-0.1462	-0.1462	-0.4921	-0.4921	-0.4921	-0.4921	-0.4921
0.500	-0.1723	-0.1066	-0.0440	-0.1434	-0.1434	-0.5240	-0.5240	-0.5240	-0.5240	-0.5240
0.525	*****	-0.1154	-0.0481	-0.1449	-0.1449	-0.5548	-0.5548	-0.5548	-0.5548	-0.5548
0.550	-0.1849	-0.1262	-0.0563	-0.1427	-0.1427	-0.5500	-0.5500	-0.5500	-0.5500	-0.5500
0.575	*****	-0.1324	-0.0542	-0.1462	-0.1462	-0.5582	-0.5582	-0.5582	-0.5582	-0.5582
0.600	-0.2038	-0.1413	-0.0715	-0.1483	-0.1483	-0.5373	-0.5373	-0.5373	-0.5373	-0.5373
0.625	*****	*****	-0.0761	-0.1489	-0.1489	-0.5090	-0.5090	-0.5090	-0.5090	-0.5090
0.650	-0.2195	-0.1504	-0.0855	-0.1524	-0.1524	-0.4736	-0.4736	-0.4736	-0.4736	-0.4736
0.675	*****	-0.1698	-0.1006	-0.1603	-0.1603	-0.4248	-0.4248	-0.4248	-0.4248	-0.4248
0.700	-0.2308	-0.1902	-0.1094	-0.1640	-0.1640	-0.3820	-0.3820	-0.3820	-0.3820	-0.3820
0.725	*****	-0.2092	*****	-0.1702	-0.1702	-0.3302	-0.3302	-0.3302	-0.3302	-0.3302
0.750	-0.2411	-0.2323	*****	-0.1796	-0.1796	-0.2570	-0.2570	-0.2570	-0.2570	-0.2570
0.775	*****	-0.2535	-0.1651	-0.1976	-0.1976	-0.1786	-0.1786	-0.1786	-0.1786	-0.1786
0.800	-0.2421	-0.2781	-0.1978	-0.2183	-0.2183	*****	*****	*****	*****	*****
0.825	*****	-0.2988	-0.2357	-0.2223	-0.2223	-0.2219	-0.2219	-0.2219	-0.2219	-0.2219
0.850	-0.2440	-0.3192	-0.2762	-0.2733	-0.2733	-0.2457	-0.2457	-0.2457	-0.2457	-0.2457
0.875	*****	-0.3383	-0.3191	-0.3240	-0.3240	-0.3614	-0.3614	-0.3614	-0.3614	-0.3614
0.900	-0.2401	-0.3560	-0.3647	-0.3846	-0.3846	-0.6413	-0.6413	-0.6413	-0.6413	-0.6413
0.925	*****	-0.3722	-0.4014	-0.4409	-0.4409	-0.8892	-0.8892	-0.8892	-0.8892	-0.8892
0.950	-0.2331	-0.3786	-0.4424	-0.4926	-0.4926	-0.6454	-0.6454	-0.6454	-0.6454	-0.6454
0.975	*****	-0.4046	-0.4747	-0.5478	-0.5478	-0.6167	-0.6167	-0.6167	-0.6167	-0.6167
1.000	-0.1016	-0.3366	-0.5168	-0.6403	-0.6403	-0.5061	-0.5061	-0.5061	-0.5061	-0.5061
	$C_{p,l}$	$C_{p,l}$	$C_{p,l}$	$C_{p,l}$	$C_{p,l}$	$C_{p,l}$	$C_{p,l}$	$C_{p,l}$	$C_{p,l}$	$C_{p,l}$
-0.200	0.0840	0.0930	0.1481	0.1481	0.1481	0.5234	0.5234	0.5234	0.5234	0.5234
-0.400	0.0749	0.0977	0.1158	0.1158	0.1158	0.7435	0.7435	0.7435	0.7435	0.7435
-0.600	0.0813	0.0921	0.1032	0.1032	0.1032	0.7406	0.7406	0.7406	0.7406	0.7406
-0.700	0.0978	0.0862	0.0964	0.0964	0.0964	0.7187	0.7187	0.7187	0.7187	0.7187
-0.800	0.1306	0.1306	0.0940	0.0940	0.0940	0.6581	0.6581	0.6581	0.6581	0.6581
-0.850	*****	0.1173	0.0979	0.0284	0.0284	-0.6690	-0.6690	-0.6690	-0.6690	-0.6690
-0.900	*****	0.1500	0.1210	0.0450	0.0450	-0.6732	-0.6732	-0.6732	-0.6732	-0.6732
-0.950	0.2233	0.1951	0.1735	0.1035	0.1035	-0.2567	-0.2567	-0.2567	-0.2567	-0.2567
-0.975	*****	0.2204	0.2011	0.1480	0.1480	-0.0760	-0.0760	-0.0760	-0.0760	-0.0760
-1.000	-0.1075	-0.3181	-0.5838	-0.5678	-0.5678	-0.4005	-0.4005	-0.4005	-0.4005	-0.4005

Medium Radius L.E.
 Run No. = 25 , Point No. = 509
 $C_N = 0.196$, $C_m = -0.0333$
 $\alpha = 4.9^\circ$, $M_\infty = 0.832$
 $R_{mac} = 59.9 \times 10^6$

Leading Edge Pressures

● starboard
 ○ port

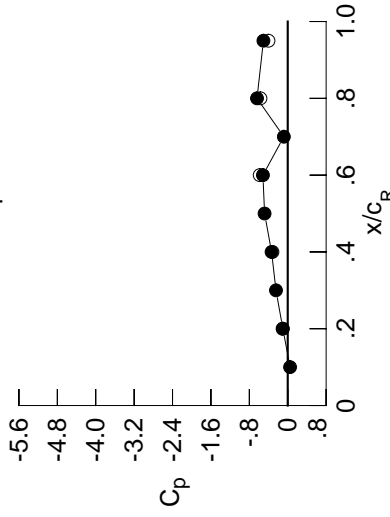

x/c_R	starb'd C_p	port C_p
0.10	0.0492	*****
0.20	-0.1016	-0.1075
0.30	-0.2449	*****
0.40	-0.3366	-0.3181
0.50	-0.4823	*****
0.60	-0.5168	-0.5838
0.70	-0.0811	*****
0.80	-0.6403	-0.5678
0.90	*****	*****
0.95	-0.5061	-0.4005

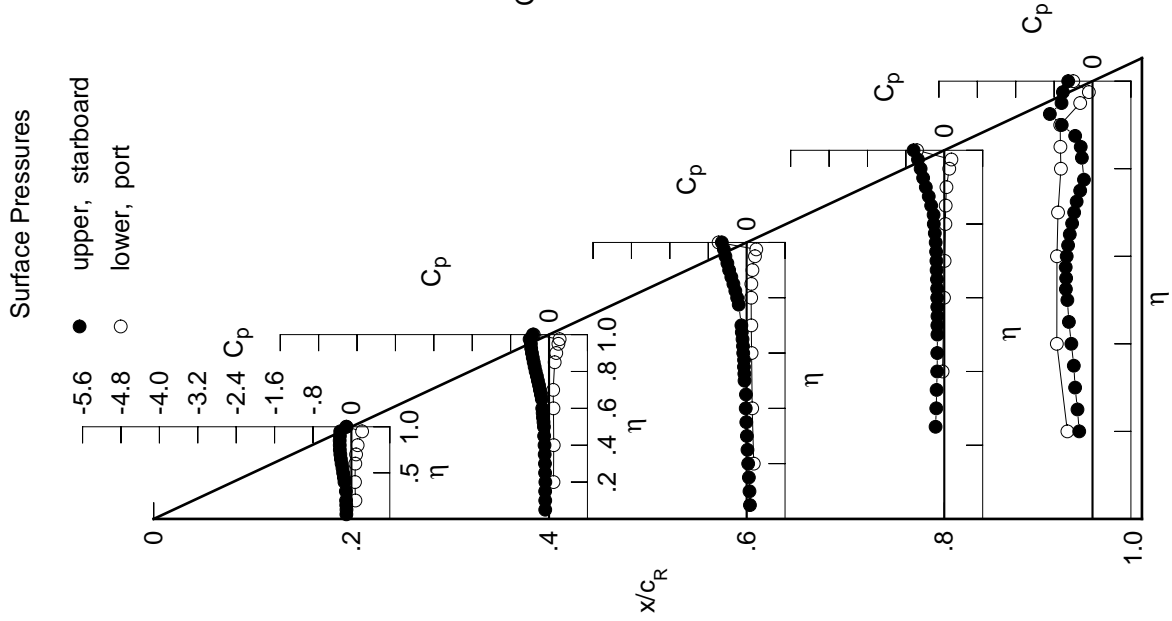
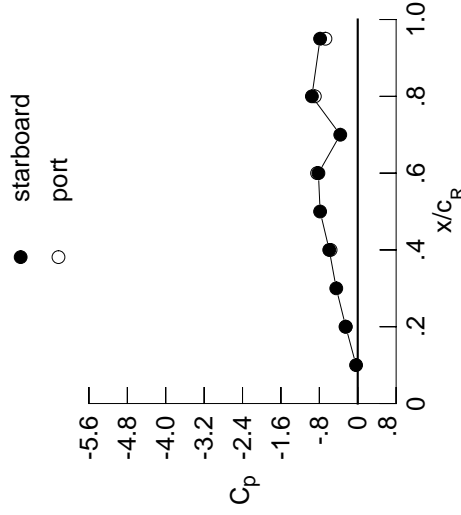

Table G2. Continued.

η	$x/c_R = .2$		$x/c_R = .4$		$x/c_R = .6$		$x/c_R = .8$		$x/c_R = .95$	
	$C_{p,u}$	$C_{p,u}$	$C_{p,u}$	$C_{p,u}$	$C_{p,u}$	$C_{p,u}$	$C_{p,u}$	$C_{p,u}$	$C_{p,u}$	$C_{p,u}$
0.050	-0.1238	-0.0957	0.0569	0.0569	0.0569	0.0569	0.0569	0.0569	0.0569	0.0569
0.100	-0.1224	-0.0976	0.0467	0.0467	0.0467	0.0467	0.0467	0.0467	0.0467	0.0467
0.150	-0.1266	-0.0983	0.0338	0.0338	0.0338	0.0338	0.0338	0.0338	0.0338	0.0338
0.200	-0.1312	-0.0951	0.0193	0.0193	0.0193	0.0193	0.0193	0.0193	0.0193	0.0193
0.250	0.0000	-0.1008	0.0035	0.0035	0.0035	0.0035	0.0035	0.0035	0.0035	0.0035
0.300	-0.1366	-0.1038	-0.0089	-0.1790	-0.1790	-0.1790	-0.1790	-0.1790	-0.1790	-0.1790
0.350	0.0000	-0.1100	-0.0220	-0.1710	-0.1710	-0.1710	-0.1710	-0.1710	-0.1710	-0.1710
0.400	-0.1669	-0.1137	-0.0339	-0.1608	-0.1608	-0.1608	-0.1608	-0.1608	-0.1608	-0.1608
0.450	-0.1822	-0.1235	-0.0305	-0.1585	-0.1585	-0.1585	-0.1585	-0.1585	-0.1585	-0.1585
0.500	-0.1992	-0.1294	-0.0614	-0.1571	-0.1571	-0.1571	-0.1571	-0.1571	-0.1571	-0.1571
0.525	0.0000	-0.1396	-0.0656	-0.1597	-0.1597	-0.1597	-0.1597	-0.1597	-0.1597	-0.1597
0.550	-0.2140	-0.1511	-0.0750	-0.1579	-0.1579	-0.1579	-0.1579	-0.1579	-0.1579	-0.1579
0.575	0.0000	-0.1582	-0.0734	-0.1612	-0.1612	-0.1612	-0.1612	-0.1612	-0.1612	-0.1612
0.600	-0.2363	-0.1688	-0.0931	-0.1642	-0.1642	-0.1642	-0.1642	-0.1642	-0.1642	-0.1642
0.625	0.0000	0.0000	-0.0962	-0.1669	-0.1669	-0.1669	-0.1669	-0.1669	-0.1669	-0.1669
0.650	-0.2555	-0.1790	-0.1096	-0.1719	-0.1719	-0.1719	-0.1719	-0.1719	-0.1719	-0.1719
0.675	0.0000	-0.2003	-0.1246	-0.1795	-0.1795	-0.1795	-0.1795	-0.1795	-0.1795	-0.1795
0.700	-0.2713	-0.2233	-0.1363	-0.1860	-0.1860	-0.1860	-0.1860	-0.1860	-0.1860	-0.1860
0.725	0.0000	-0.2448	0.0000	-0.1939	-0.1939	-0.1939	-0.1939	-0.1939	-0.1939	-0.1939
0.750	-0.2867	-0.2727	0.0000	-0.2079	-0.2079	-0.2079	-0.2079	-0.2079	-0.2079	-0.2079
0.775	0.0000	-0.2976	-0.1989	-0.2295	-0.2295	-0.2295	-0.2295	-0.2295	-0.2295	-0.2295
0.800	-0.2938	-0.3279	-0.2368	-0.2532	-0.2532	-0.2532	-0.2532	-0.2532	-0.2532	-0.2532
0.825	0.0000	-0.3543	-0.2781	-0.2583	-0.2583	-0.2583	-0.2583	-0.2583	-0.2583	-0.2583
0.850	-0.3031	-0.3816	-0.3263	-0.3124	-0.3124	-0.3124	-0.3124	-0.3124	-0.3124	-0.3124
0.875	0.0000	-0.4090	-0.3803	-0.3686	-0.3686	-0.3686	-0.3686	-0.3686	-0.3686	-0.3686
0.900	-0.3093	-0.4378	-0.4392	-0.4408	-0.4408	-0.4408	-0.4408	-0.4408	-0.4408	-0.4408
0.925	0.0000	-0.4664	-0.4952	-0.5156	-0.5156	-0.5156	-0.5156	-0.5156	-0.5156	-0.5156
0.950	-0.3201	-0.4852	-0.5550	-0.5916	-0.5916	-0.5916	-0.5916	-0.5916	-0.5916	-0.5916
0.975	0.0000	-0.5485	-0.6307	-0.6830	-0.6830	-0.6830	-0.6830	-0.6830	-0.6830	-0.6830
1.000	-0.2490	-0.5934	-0.8189	-0.9553	-0.9553	-0.9553	-0.9553	-0.9553	-0.9553	-0.9553
-0.200	$C_{p,l}$	0.1060	0.1098	0.1623	0.1623	0.1623	0.1623	0.1623	0.1623	0.1623
-0.400	$C_{p,l}$	0.0986	0.1165	0.1315	0.1315	0.1315	0.1315	0.1315	0.1315	0.1315
-0.600	$C_{p,l}$	0.1080	0.1133	0.1191	0.1191	0.1191	0.1191	0.1191	0.1191	0.1191
-0.700	$C_{p,l}$	0.1268	0.1116	0.1160	0.1213	0.1213	0.1213	0.1213	0.1213	0.1213
-0.800	$C_{p,l}$	0.1601	0.1181	0.1181	0.1181	0.1181	0.1181	0.1181	0.1181	0.1181
-0.850	$C_{p,l}$	0.1478	0.1478	0.1251	0.1251	0.1251	0.1251	0.1251	0.1251	0.1251
-0.900	$C_{p,l}$	0.1791	0.1791	0.1496	0.1496	0.1496	0.1496	0.1496	0.1496	0.1496
-0.950	$C_{p,l}$	0.2367	0.2141	0.1945	0.1945	0.1945	0.1945	0.1945	0.1945	0.1945
-0.975	$C_{p,l}$	0.2188	0.2188	0.2047	0.2047	0.2047	0.2047	0.2047	0.2047	0.2047
-1.000	$C_{p,l}$	-0.2547	-0.5653	-0.8469	-0.8932	-0.8932	-0.8932	-0.8932	-0.8932	-0.8932

Medium Radius L.E.
 Run No. = 25 , Point No. = 510
 $C_N = 0.238$, $C_m = -0.0400$
 $\alpha = 6.0^\circ$, $M_\infty = 0.833$
 $R_{mac} = 60.0 \times 10^6$

Leading Edge Pressures



x/c_R	starb'd C_p	port C_p
0.10	-0.0343	0.0000
0.20	-0.2490	-0.2547
0.30	-0.4475	0.0000
0.40	-0.5934	-0.5653
0.50	-0.7837	0.0000
0.60	-0.8189	-0.8469
0.70	-0.3640	0.0000
0.80	-0.9553	-0.8932
0.90	0.0000	0.0000
0.95	-0.7843	-0.6729

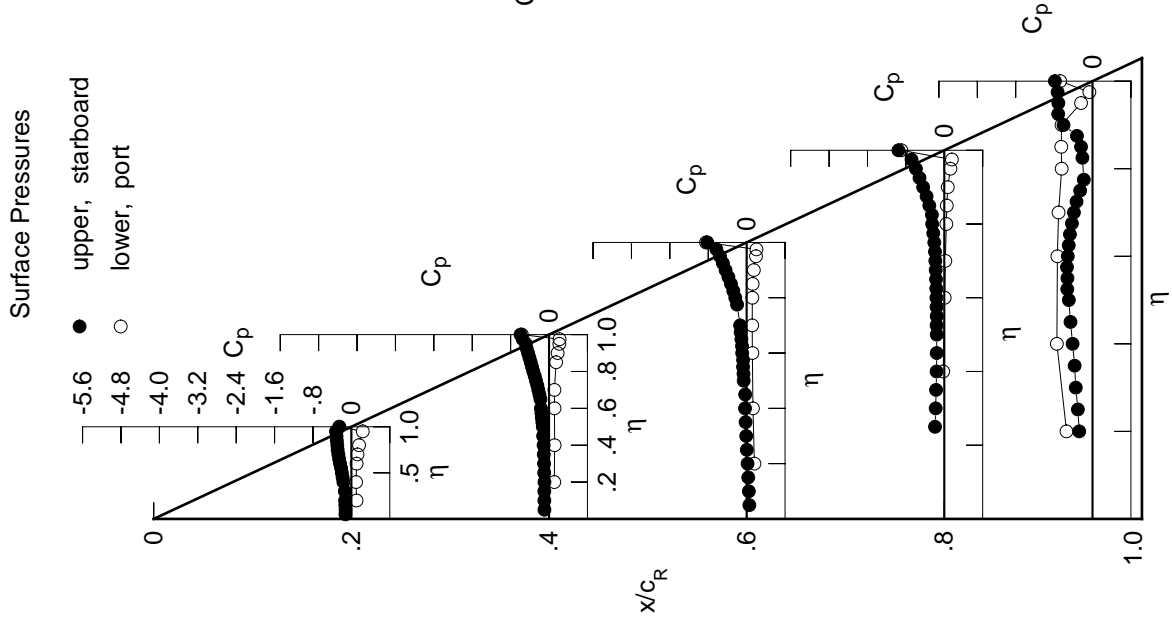
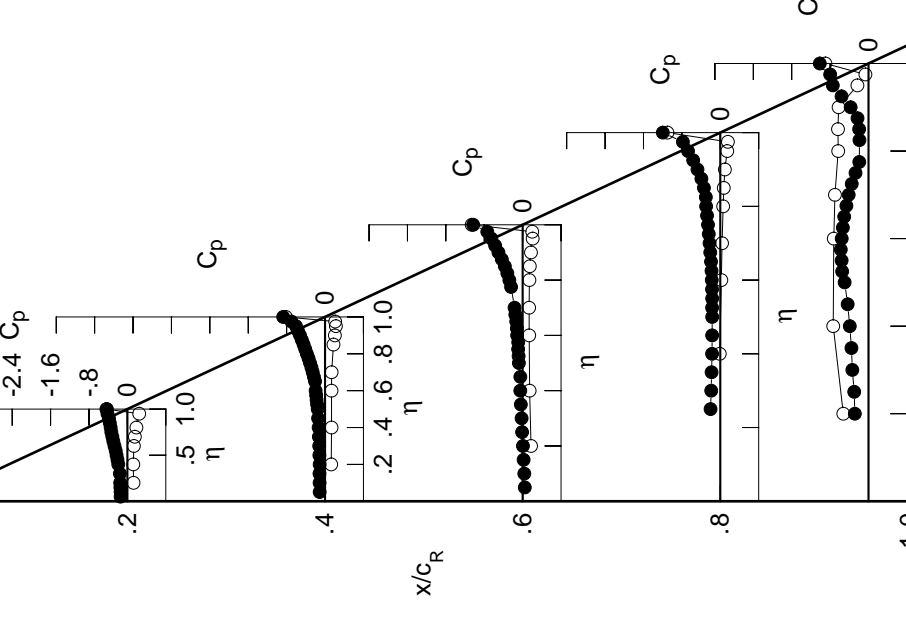
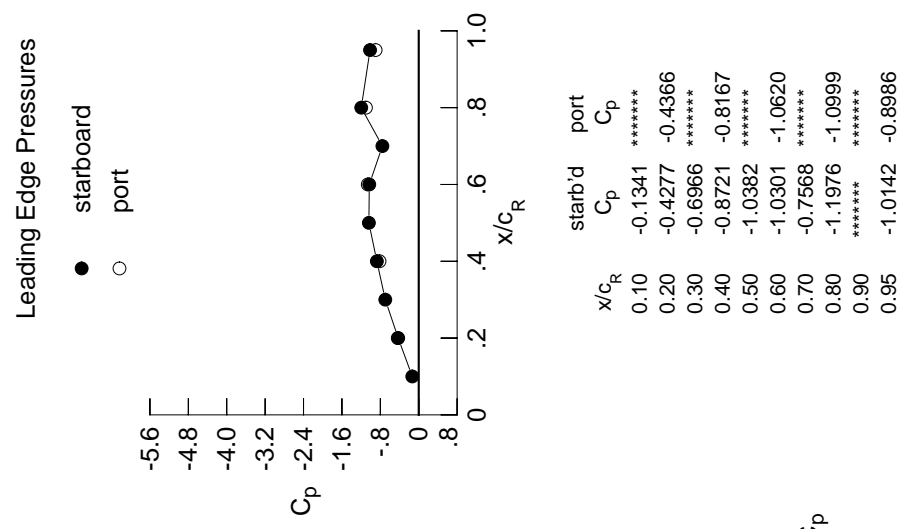

Table G2. Continued.

η	x/c_R .2	x/c_R .4	x/c_R .6	x/c_R .8	x/c_R .95
	$C_{p,u}$	$C_{p,u}$	$C_{p,u}$	$C_{p,u}$	$C_{p,u}$
0.050	-0.1415	-0.1123	0.0450	*****	*****
0.100	-0.1417	-0.1139	0.0341	*****	*****
0.150	-0.1463	-0.1157	0.0204	*****	*****
0.200	-0.1506	-0.1124	0.0061	*****	-0.2851
0.250	*****	-0.1181	-0.0108	-0.2028	-0.2978
0.300	-0.1569	-0.1217	-0.0218	-0.1889	-0.3370
0.350	*****	-0.1290	-0.0377	-0.1816	-0.3553
0.400	-0.1895	-0.1335	-0.0491	-0.1716	-0.3907
0.450	-0.2062	-0.1449	-0.0477	-0.1696	-0.4343
0.500	-0.2255	-0.1524	-0.0786	-0.1689	-0.4972
0.525	*****	-0.1646	-0.0843	-0.1704	-0.5491
0.550	-0.2437	-0.1763	-0.0933	-0.1690	-0.5603
0.575	*****	-0.1844	-0.0923	-0.1720	-0.5778
0.600	-0.2687	-0.1962	-0.1146	-0.1776	-0.5586
0.625	*****	*****	-0.1199	-0.1823	-0.5348
0.650	-0.2928	-0.2083	-0.1338	-0.1929	-0.5061
0.675	*****	-0.2324	-0.1526	-0.2090	-0.4606
0.700	-0.3130	-0.2564	-0.1685	-0.2241	-0.4126
0.725	*****	-0.2822	*****	-0.2397	-0.3493
0.750	-0.3341	-0.3125	*****	-0.2562	-0.2706
0.775	*****	-0.3432	-0.2407	-0.2763	-0.1917
0.800	-0.3486	-0.3788	-0.2769	-0.2951	*****
0.825	*****	-0.4120	-0.3195	-0.3011	-0.1885
0.850	-0.3667	-0.4465	-0.3708	-0.3405	-0.1953
0.875	*****	-0.4832	-0.4337	-0.3936	-0.2289
0.900	-0.3843	-0.5212	-0.5040	-0.4754	-0.3722
0.925	*****	-0.5643	-0.5738	-0.5651	-0.5617
0.950	-0.4160	-0.6057	-0.6513	-0.6717	-0.7436
0.975	*****	-0.7001	-0.7366	-0.7793	-0.7992
1.000	-0.4277	-0.8721	-1.0301	-1.1976	-1.0142
	$C_{p,l}$	$C_{p,l}$	$C_{p,l}$	$C_{p,l}$	$C_{p,l}$
-0.200	0.1278	0.1290	0.1750	*****	-0.5248
-0.400	0.1232	0.1359	0.1457	-0.0111	-0.7349
-0.600	0.1354	0.1350	0.1365	0.0218	-0.7237
-0.700	0.1552	0.1366	0.1349	0.0368	-0.6992
-0.800	0.1880	*****	0.1407	0.0603	-0.6314
-0.850	*****	0.1758	0.1498	0.0725	-0.6363
-0.900	*****	0.2045	0.1739	0.0957	-0.6229
-0.950	0.2454	0.2266	0.2084	0.1448	-0.2310
-0.975	*****	0.2110	0.1998	0.1585	-0.0651
-1.000	-0.4366	-0.8167	-1.0620	-1.0999	-0.8986

Medium Radius L.E.
 Run No. = 25, Point No. = 511
 $C_N = 0.281$, $C_m = -0.0466$
 $\alpha = 7.1^\circ$, $M_\infty = 0.829$
 $R_{mac} = 59.8 \times 10^6$



x/c_R	starb'd C_p	port C_p
0.10	-0.1341	*****
0.20	-0.4277	-0.4366
0.30	-0.6966	*****
0.40	-0.8721	-0.8167
0.50	-1.0382	*****
0.60	-1.0301	-1.0620
0.70	-0.7568	*****
0.80	-1.1976	-1.0999
0.90	*****	*****
0.95	-1.0142	-0.8986

Table G2. Continued.

η	$x/c_R = .2$		$x/c_R = .4$		$x/c_R = .6$		$x/c_R = .8$		$x/c_R = .95$	
	$C_{p,u}$	$C_{p,u}$	$C_{p,u}$	$C_{p,u}$	$C_{p,u}$	$C_{p,u}$	$C_{p,u}$	$C_{p,u}$	$C_{p,u}$	$C_{p,u}$
0.050	-0.1569	-0.1281	0.0323	*****	*****	*****	*****	*****	*****	
0.100	-0.1589	-0.1294	0.0214	*****	*****	*****	*****	*****	*****	
0.150	-0.1651	-0.1320	0.0069	*****	*****	*****	*****	*****	*****	
0.200	-0.1697	-0.1300	-0.0071	*****	*****	*****	*****	*****	-0.2888	
0.250	*****	-0.1360	-0.0242	-0.2180	-0.2867	*****	*****	*****	*****	
0.300	-0.1773	-0.1398	-0.0372	-0.2046	-0.3184	*****	*****	*****	*****	
0.350	*****	-0.1480	-0.0524	-0.1977	-0.3361	*****	*****	*****	*****	
0.400	-0.2119	-0.1544	-0.0650	-0.1860	-0.3909	*****	*****	*****	*****	
0.450	-0.2307	-0.1660	-0.0638	-0.1834	-0.4792	*****	*****	*****	*****	
0.500	-0.2522	-0.1758	-0.0951	-0.1820	-0.5421	*****	*****	*****	*****	
0.525	*****	-0.1869	-0.1031	-0.1883	-0.5681	*****	*****	*****	*****	
0.550	-0.2730	-0.2028	-0.1151	-0.1936	-0.5466	*****	*****	*****	*****	
0.575	*****	-0.2124	-0.1201	-0.2037	-0.5449	*****	*****	*****	*****	
0.600	-0.3011	-0.2267	-0.1493	-0.2146	-0.5234	*****	*****	*****	*****	
0.625	*****	*****	-0.1611	-0.2244	-0.5095	*****	*****	*****	*****	
0.650	-0.3291	-0.2450	-0.1805	-0.2360	-0.4945	*****	*****	*****	*****	
0.675	*****	-0.2684	-0.2009	-0.2520	-0.4779	*****	*****	*****	*****	
0.700	-0.3549	-0.2934	-0.2155	-0.2740	-0.4768	*****	*****	*****	*****	
0.725	*****	-0.3209	*****	-0.2988	-0.4734	*****	*****	*****	*****	
0.750	-0.3822	-0.3534	*****	-0.3065	-0.4628	*****	*****	*****	*****	
0.775	*****	-0.3873	-0.2775	-0.3144	-0.4588	*****	*****	*****	*****	
0.800	-0.4048	-0.4272	-0.3112	-0.3437	*****	*****	*****	*****	*****	
0.825	*****	-0.4653	-0.3543	-0.3821	-0.4736	*****	*****	*****	*****	
0.850	-0.4332	-0.5069	-0.4064	-0.4218	-0.4556	*****	*****	*****	*****	
0.875	*****	-0.5548	-0.4713	-0.4331	-0.5315	*****	*****	*****	*****	
0.900	-0.4621	-0.6049	-0.5531	-0.5201	-0.5837	*****	*****	*****	*****	
0.925	*****	-0.6595	-0.6596	-0.6076	-0.8569	*****	*****	*****	*****	
0.950	-0.5201	-0.7134	-0.8211	-0.7444	-0.7140	*****	*****	*****	*****	
0.975	*****	-0.8093	-1.1505	-1.0324	-0.7706	*****	*****	*****	*****	
1.000	-0.6327	-1.0918	-1.1491	-1.3215	-1.1243	*****	*****	*****	*****	
-0.200	$C_{p,l}$	$C_{p,l}$	$C_{p,l}$	$C_{p,l}$	$C_{p,l}$	$C_{p,l}$	$C_{p,l}$	$C_{p,l}$	$C_{p,l}$	
-0.400	0.1521	0.1509	0.1921	*****	*****	-0.5503	*****	*****	*****	
-0.600	0.1483	0.1580	0.1634	0.0055	-0.7241	*****	*****	*****	*****	
-0.700	0.1636	0.1596	0.1557	0.0392	-0.7101	*****	*****	*****	*****	
-0.800	0.1837	0.1622	0.1557	0.0542	-0.6831	*****	*****	*****	*****	
-0.850	0.2146	*****	0.1640	0.0796	-0.6137	*****	*****	*****	*****	
-0.900	*****	0.2023	0.1742	0.0935	-0.6153	*****	*****	*****	*****	
-0.950	*****	0.2271	0.1969	0.1178	-0.5940	*****	*****	*****	*****	
-0.975	0.2490	0.2354	0.2202	0.1598	-0.2156	*****	*****	*****	*****	
-1.000	*****	0.1969	0.1925	0.1585	-0.0554	*****	*****	*****	*****	
	-0.6494	-1.0372	-1.2143	-1.2288	-0.9578	*****	*****	*****	*****	

Medium Radius L.E.
 Run No. = 25 , Point No. = 512
 $C_N = 0.333$, $C_m = -0.0576$
 $\alpha = 8.1^\circ$, $M_\infty = 0.828$
 $R_{mac} = 59.8 \times 10^6$

Leading Edge Pressures

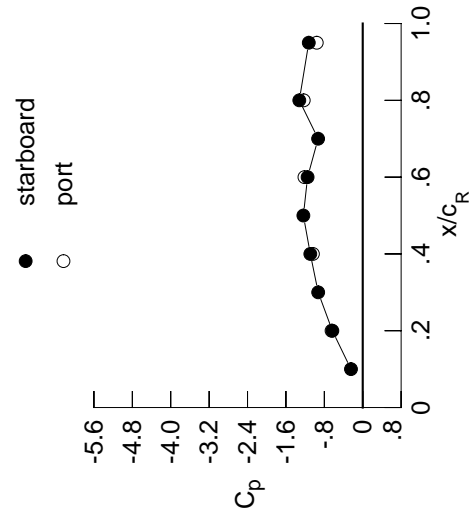

x/c_R	starb'd C_p	port C_p
0.10	-0.2452	*****
0.20	-0.6327	-0.6494
0.30	-0.9279	*****
0.40	-1.0918	-1.0372
0.50	-1.2365	*****
0.60	-1.1491	-1.2143
0.70	-0.9296	*****
0.80	-1.3215	-1.2288
0.90	*****	*****
0.95	-1.1243	-0.9578

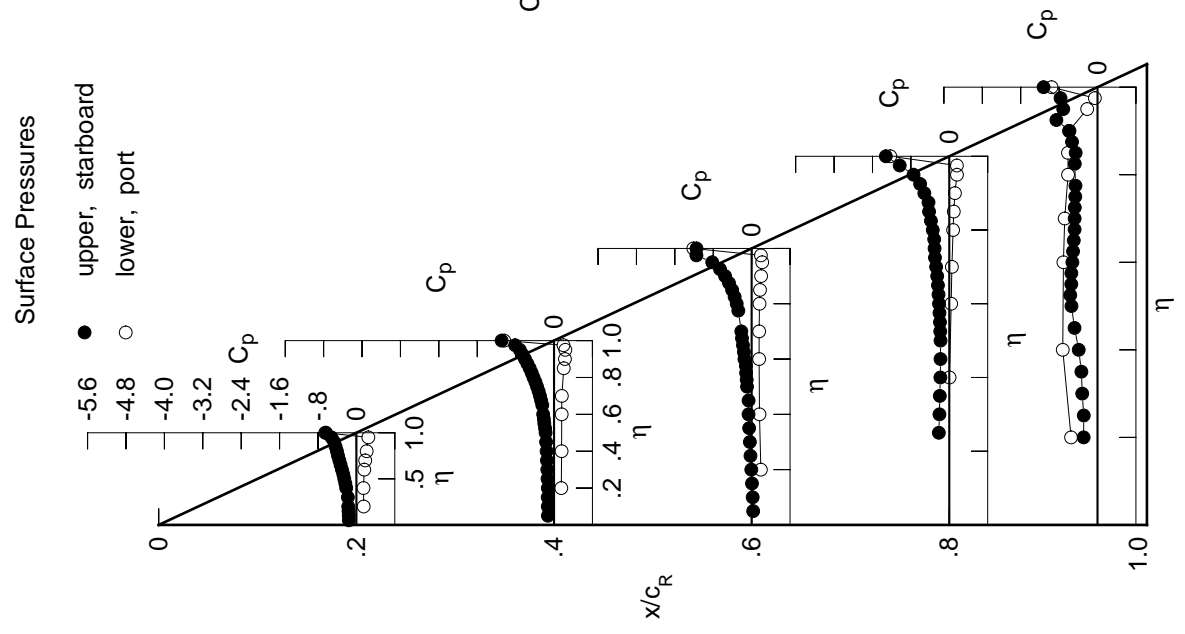
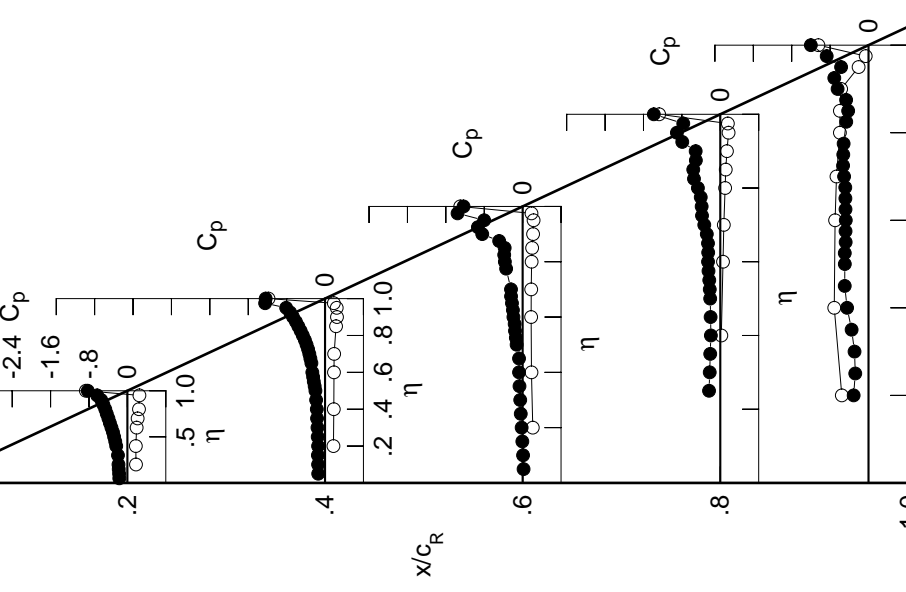
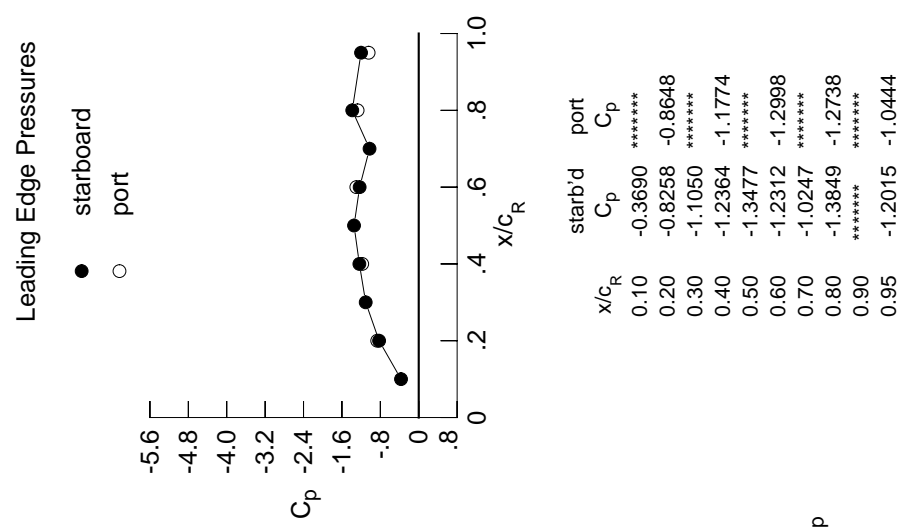

Table G2. Continued.

η	$x/c_R = .2$		$x/c_R = .4$		$x/c_R = .6$		$x/c_R = .8$		$x/c_R = .95$	
	$C_{p,u}$	$C_{p,u}$	$C_{p,u}$	$C_{p,u}$	$C_{p,u}$	$C_{p,u}$	$C_{p,u}$	$C_{p,u}$	$C_{p,u}$	$C_{p,u}$
0.050	-0.1686	-0.1425	0.0193	*****	*****	*****	*****	*****	*****	*****
0.100	-0.1726	-0.1449	0.0087	*****	*****	*****	*****	*****	*****	*****
0.150	-0.1804	-0.1487	-0.0063	*****	*****	*****	*****	*****	*****	*****
0.200	-0.1853	-0.1450	-0.0210	*****	*****	*****	*****	*****	*****	-0.3097
0.250	*****	-0.1526	-0.0389	-0.2345	-0.2762	*****	*****	*****	*****	*****
0.300	-0.1959	-0.1575	-0.0504	-0.2199	-0.2909	*****	*****	*****	*****	*****
0.350	*****	-0.1668	-0.0654	-0.2096	-0.3522	*****	*****	*****	*****	*****
0.400	-0.2326	-0.1711	-0.0753	-0.1962	-0.4462	*****	*****	*****	*****	*****
0.450	-0.2530	-0.1859	-0.0750	-0.2018	-0.4955	*****	*****	*****	*****	*****
0.500	-0.2759	-0.2004	-0.1259	-0.2100	-0.4938	*****	*****	*****	*****	*****
0.525	*****	-0.2164	-0.1416	-0.2193	-0.4941	*****	*****	*****	*****	*****
0.550	-0.2999	-0.2342	-0.1594	-0.2292	-0.4759	*****	*****	*****	*****	*****
0.575	*****	-0.2482	-0.1663	-0.2456	-0.4784	*****	*****	*****	*****	*****
0.600	-0.3323	-0.2651	-0.1923	-0.2553	-0.4739	*****	*****	*****	*****	*****
0.625	*****	*****	-0.2027	-0.2518	-0.4795	*****	*****	*****	*****	*****
0.650	-0.3645	-0.2844	-0.2226	-0.2560	-0.4817	*****	*****	*****	*****	*****
0.675	*****	-0.3056	-0.2419	-0.2808	-0.4842	*****	*****	*****	*****	*****
0.700	-0.3954	-0.3276	-0.2427	-0.3337	-0.5088	*****	*****	*****	*****	*****
0.725	*****	-0.3525	*****	-0.3808	-0.5298	*****	*****	*****	*****	*****
0.750	-0.4293	-0.3844	*****	-0.3882	-0.5254	*****	*****	*****	*****	*****
0.775	*****	-0.4200	-0.3437	-0.4069	-0.5182	*****	*****	*****	*****	*****
0.800	-0.4605	-0.4636	-0.3705	-0.4666	*****	*****	*****	*****	*****	*****
0.825	*****	-0.5079	-0.3840	-0.5478	-0.4640	*****	*****	*****	*****	*****
0.850	-0.5008	-0.5565	-0.3745	-0.5631	-0.4236	*****	*****	*****	*****	*****
0.875	*****	-0.6076	-0.4892	-0.5086	-0.4666	*****	*****	*****	*****	*****
0.900	-0.5449	-0.6673	-0.8420	-0.5129	-0.6443	*****	*****	*****	*****	*****
0.925	*****	-0.7274	-0.9318	-0.7922	-0.7130	*****	*****	*****	*****	*****
0.950	-0.6301	-0.8094	-0.8019	-0.9041	-0.5709	*****	*****	*****	*****	*****
0.975	*****	-1.2479	-1.3556	-0.7708	-0.8716	*****	*****	*****	*****	*****
1.000	-0.8258	-1.2364	-1.2312	-1.3849	-1.2015	*****	*****	*****	*****	*****
-0.200	$C_{p,l}$	$C_{p,l}$	$C_{p,l}$	$C_{p,l}$	$C_{p,l}$	$C_{p,l}$	$C_{p,l}$	$C_{p,l}$	$C_{p,l}$	$C_{p,l}$
-0.400	0.1792	0.1754	0.2113	*****	*****	*****	*****	*****	*****	-0.5560
-0.600	0.1757	0.1827	0.1837	0.0216	-0.7137	*****	*****	*****	*****	*****
-0.700	0.1927	0.1866	0.1771	0.0568	-0.6964	*****	*****	*****	*****	*****
-0.800	0.2132	0.1895	0.1787	0.0736	-0.6669	*****	*****	*****	*****	*****
-0.850	0.2415	*****	0.1868	0.1005	-0.5962	*****	*****	*****	*****	*****
-0.900	*****	0.2293	0.1976	0.1137	-0.5963	*****	*****	*****	*****	*****
-0.950	*****	0.2491	0.2173	0.1383	-0.5701	*****	*****	*****	*****	*****
-0.975	0.2506	0.2431	0.2280	0.1728	-0.2060	*****	*****	*****	*****	*****
-1.000	0.2506	0.1829	0.1839	0.1577	-0.0586	*****	*****	*****	*****	*****
-1.000	-0.8648	-1.1774	-1.2998	-1.2738	-1.0444	*****	*****	*****	*****	*****

Medium Radius L.E.
 Run No. = 25 , Point No. = 513
 $C_N = 0.386$, $C_m = -0.0675$
 $\alpha = 9.1^\circ$, $M_\infty = 0.829$
 $R_{mac} = 59.7 \times 10^6$



x/c_R	starb'd C_p	port C_p
0.10	-0.3690	*****
0.20	-0.8258	-0.8648
0.30	-1.1050	*****
0.40	-1.2364	-1.1774
0.50	-1.3477	*****
0.60	-1.2312	-1.2998
0.70	-1.0247	*****
0.80	-1.3849	-1.2738
0.90	*****	*****
0.95	-1.2015	-1.0444

Table G2. Continued.

η	$x/c_R = 0.2$		$x/c_R = 0.4$		$x/c_R = 0.6$		$x/c_R = 0.8$		$x/c_R = 0.95$	
	$C_{p,u}$	$C_{p,u}$	$C_{p,u}$	$C_{p,u}$	$C_{p,u}$	$C_{p,u}$	$C_{p,u}$	$C_{p,u}$	$C_{p,u}$	$C_{p,u}$
0.050	-0.1856	-0.1655	-0.0032	*****	*****	*****	*****	*****	*****	*****
0.100	-0.1923	-0.1692	-0.0150	*****	*****	*****	*****	*****	*****	*****
0.150	-0.2011	-0.1717	-0.0320	*****	*****	*****	*****	*****	*****	*****
0.200	-0.2075	-0.1700	-0.0464	*****	*****	*****	*****	*****	*****	-0.2546
0.250	*****	-0.1788	-0.0635	-0.2578	-0.2578	-0.2119	*****	*****	*****	-0.2119
0.300	-0.2197	-0.1830	-0.0711	-0.2394	-0.2394	-0.3073	*****	*****	*****	-0.3073
0.350	*****	-0.1910	-0.0884	-0.2321	-0.2321	-0.3893	*****	*****	*****	-0.3893
0.400	-0.2582	-0.1970	-0.1097	-0.2216	-0.2216	-0.4746	*****	*****	*****	-0.4746
0.450	-0.2791	-0.2246	-0.1195	-0.2355	-0.2355	-0.5057	*****	*****	*****	-0.5057
0.500	-0.3046	-0.2493	-0.1726	-0.2498	-0.2498	-0.4945	*****	*****	*****	-0.4945
0.525	*****	-0.2683	-0.1932	-0.2579	-0.2579	-0.4931	*****	*****	*****	-0.4931
0.550	-0.3315	-0.2852	-0.2133	-0.2661	-0.2661	-0.4761	*****	*****	*****	-0.4761
0.575	*****	-0.2942	-0.2193	-0.2752	-0.2752	-0.4763	*****	*****	*****	-0.4763
0.600	-0.3670	-0.3057	-0.2466	-0.2848	-0.2848	-0.4675	*****	*****	*****	-0.4675
0.625	*****	*****	-0.2523	-0.2886	-0.2886	-0.4732	*****	*****	*****	-0.4732
0.650	-0.4051	-0.3245	-0.2680	-0.2976	-0.2976	-0.5004	*****	*****	*****	-0.5004
0.675	*****	-0.3481	-0.2962	-0.3230	-0.3230	-0.5496	*****	*****	*****	-0.5496
0.700	-0.4422	-0.3724	-0.3225	-0.3787	-0.3787	-0.6298	*****	*****	*****	-0.6298
0.725	*****	-0.3944	*****	-0.4843	-0.4843	-0.6915	*****	*****	*****	-0.6915
0.750	-0.4816	-0.4230	*****	-0.5953	-0.5953	-0.7155	*****	*****	*****	-0.7155
0.775	*****	-0.4478	-0.4130	-0.6825	-0.6825	-0.7163	*****	*****	*****	-0.7163
0.800	-0.5188	-0.4833	-0.4769	-0.7223	-0.7223	*****	*****	*****	*****	-0.7223
0.825	*****	-0.5226	-0.5145	-0.7423	-0.7423	-0.6419	*****	*****	*****	-0.6419
0.850	-0.5665	-0.6158	-0.5924	-0.7155	-0.7155	-0.5928	*****	*****	*****	-0.5928
0.875	*****	-0.7525	-0.8637	-0.6777	-0.6777	-0.5645	*****	*****	*****	-0.5645
0.900	-0.6277	-0.7666	-1.0210	-0.7134	-0.7134	-0.5506	*****	*****	*****	-0.5506
0.925	*****	-0.8836	-1.0918	-0.8441	-0.8441	-0.5060	*****	*****	*****	-0.5060
0.950	-0.7326	-1.2644	-1.0819	-0.8366	-0.8366	-0.4339	*****	*****	*****	-0.4339
0.975	*****	-1.4303	-1.0273	-0.7207	-0.7207	-0.3654	*****	*****	*****	-0.3654
1.000	-0.9948	-1.3388	-1.2534	-1.3431	-1.3431	-0.6065	*****	*****	*****	-0.6065
-0.200	$C_{p,l}$	$C_{p,l}$	$C_{p,l}$	$C_{p,l}$	$C_{p,l}$	$C_{p,l}$	$C_{p,l}$	$C_{p,l}$	$C_{p,l}$	$C_{p,l}$
-0.400	0.2047	0.1981	0.2285	*****	*****	-0.6171	*****	*****	*****	-0.6171
-0.600	0.2037	0.2062	0.2011	0.0365	-0.7124	*****	*****	*****	*****	-0.7124
-0.700	0.2215	0.2100	0.1947	0.0724	-0.6923	*****	*****	*****	*****	-0.6923
-0.800	0.2416	0.2154	0.1991	0.0885	-0.6601	*****	*****	*****	*****	-0.6601
-0.850	0.2670	*****	0.2087	0.1165	-0.5856	*****	*****	*****	*****	-0.5856
-0.900	*****	0.2539	0.2196	0.1309	-0.5811	*****	*****	*****	*****	-0.5811
-0.950	*****	0.2677	0.2367	0.1552	-0.5481	*****	*****	*****	*****	-0.5481
-0.975	0.2477	0.2475	0.2358	0.1821	-0.1857	*****	*****	*****	*****	-0.1857
-1.000	*****	0.1682	0.1768	0.1571	-0.0321	*****	*****	*****	*****	-0.0321
	-1.0573	-1.2631	-1.3489	-1.2495	-0.6255	*****	*****	*****	*****	-0.6255

Medium Radius L.E.
 Run No. = 25 , Point No. = 514
 $C_N = 0.441$, $C_m = -0.0761$
 $\alpha = 10.2^\circ$, $M_\infty = 0.827$
 $R_{mac} = 59.8 \times 10^6$

Leading Edge Pressures

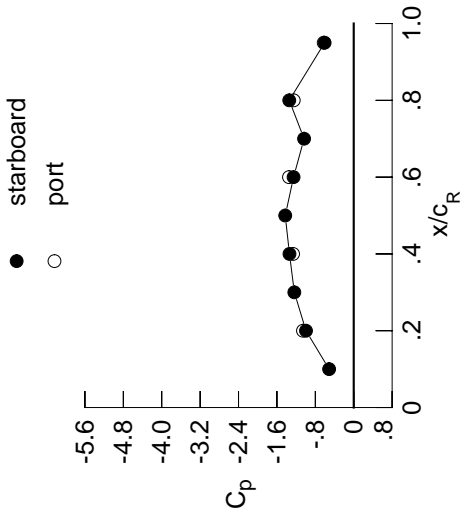

x/c_R	starb'd C_p	port C_p
0.10	-0.5125	*****
0.20	-0.9948	-1.0573
0.30	-1.2374	*****
0.40	-1.3388	-1.2631
0.50	-1.4268	*****
0.60	-1.2534	-1.3489
0.70	-1.0346	*****
0.80	-1.3431	-1.2495
0.90	*****	*****
0.95	-0.6065	-0.6255

Surface Pressures

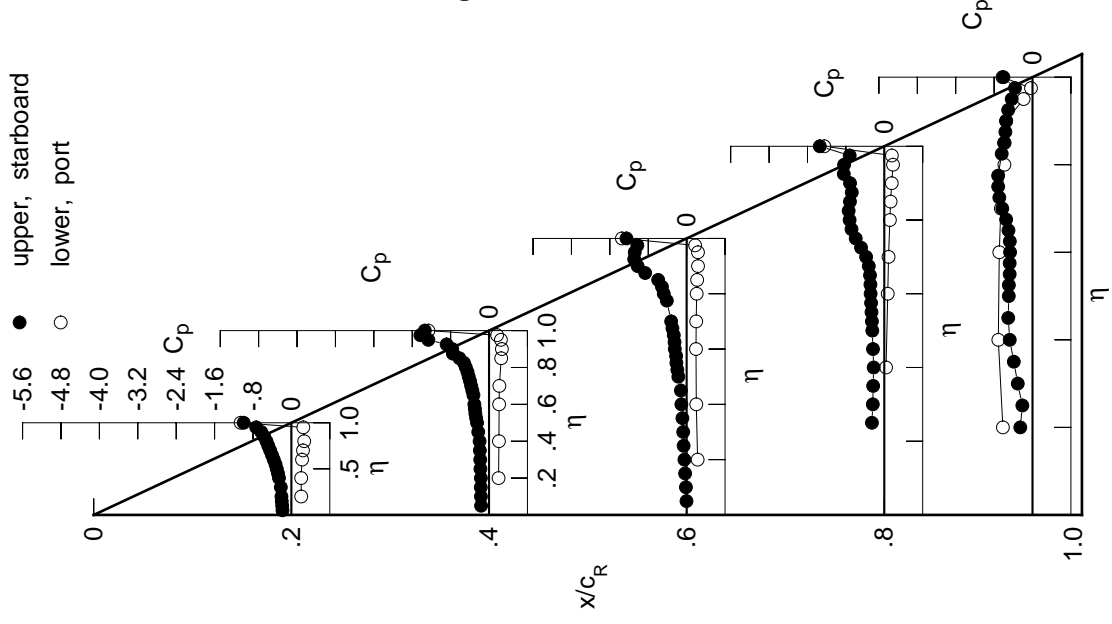
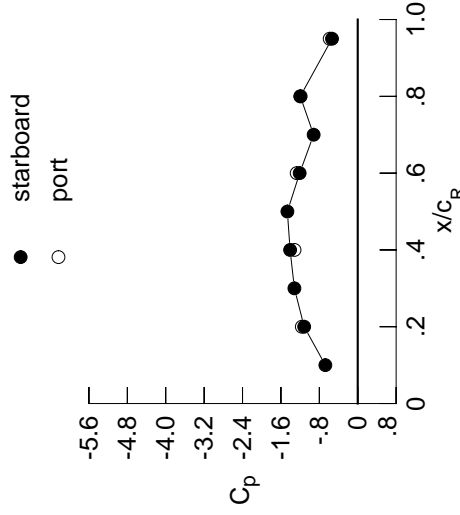

Table G2. Continued.

η	$x/c_R = .2$		$x/c_R = .4$		$x/c_R = .6$		$x/c_R = .8$		$x/c_R = .95$	
	$C_{p,u}$	$C_{p,u}$	$C_{p,u}$	$C_{p,u}$	$C_{p,u}$	$C_{p,u}$	$C_{p,u}$	$C_{p,u}$	$C_{p,u}$	$C_{p,u}$
0.050	-0.2039	-0.1972	-0.0327	*****	*****	*****	*****	*****	*****	*****
0.100	-0.2105	-0.1996	-0.0449	*****	*****	*****	*****	*****	*****	*****
0.150	-0.2241	-0.2034	-0.0622	*****	*****	*****	*****	*****	*****	*****
0.200	-0.2313	-0.2040	-0.0740	*****	*****	*****	*****	*****	*****	*****
0.250	*****	-0.2104	-0.0891	-0.2772	-0.2467	*****	*****	*****	*****	*****
0.300	-0.2457	-0.2108	-0.1028	-0.2603	-0.3468	*****	*****	*****	*****	*****
0.350	*****	-0.2262	-0.1251	-0.2530	-0.4061	*****	*****	*****	*****	*****
0.400	-0.2844	-0.2479	-0.1476	-0.2477	-0.4594	*****	*****	*****	*****	*****
0.450	-0.3077	-0.2806	-0.1660	-0.2457	-0.4892	*****	*****	*****	*****	*****
0.500	-0.3367	-0.3064	-0.2134	-0.2562	-0.4904	*****	*****	*****	*****	*****
0.525	*****	-0.3142	-0.2229	-0.2628	-0.4978	*****	*****	*****	*****	*****
0.550	-0.3659	-0.3177	-0.2393	-0.2616	-0.4920	*****	*****	*****	*****	*****
0.575	*****	-0.3181	-0.2618	-0.2632	-0.5105	*****	*****	*****	*****	*****
0.600	-0.4038	-0.3248	-0.3226	-0.2714	-0.5142	*****	*****	*****	*****	*****
0.625	*****	*****	-0.3460	-0.2839	-0.5397	*****	*****	*****	*****	*****
0.650	-0.4427	-0.3834	-0.3668	-0.3322	-0.6048	*****	*****	*****	*****	*****
0.675	*****	-0.4476	-0.3851	-0.4451	-0.6961	*****	*****	*****	*****	*****
0.700	-0.4843	-0.4742	-0.4079	-0.6245	-0.8013	*****	*****	*****	*****	*****
0.725	*****	-0.4699	*****	-0.8278	-0.8724	*****	*****	*****	*****	*****
0.750	-0.5314	-0.4724	*****	-0.9474	-0.9044	*****	*****	*****	*****	*****
0.775	*****	-0.4689	-0.7239	-1.0012	-0.8853	*****	*****	*****	*****	*****
0.800	-0.5774	-0.4788	-0.7977	-0.9466	*****	*****	*****	*****	*****	*****
0.825	*****	-0.6009	-0.8605	-0.8857	-0.6783	*****	*****	*****	*****	*****
0.850	-0.6392	-0.9004	-0.9381	-0.7831	-0.5870	*****	*****	*****	*****	*****
0.875	*****	-1.0236	-1.0216	-0.7068	-0.5264	*****	*****	*****	*****	*****
0.900	-0.7019	-0.9029	-1.0367	-0.6932	-0.4743	*****	*****	*****	*****	*****
0.925	*****	-0.8923	-0.9922	-0.7503	-0.4417	*****	*****	*****	*****	*****
0.950	-0.8447	-1.4448	-0.9364	-0.8076	-0.3877	*****	*****	*****	*****	*****
0.975	*****	-1.4395	-0.8979	-0.7036	-0.3321	*****	*****	*****	*****	*****
1.000	-1.1159	-1.4091	-1.2094	-1.1968	-0.5359	*****	*****	*****	*****	*****
$C_{p,l}$	$C_{p,l}$	$C_{p,l}$	$C_{p,l}$	$C_{p,l}$	$C_{p,l}$	$C_{p,l}$	$C_{p,l}$	$C_{p,l}$	$C_{p,l}$	$C_{p,l}$
-0.200	0.2310	0.2199	0.2446	*****	-0.6138	*****	*****	*****	*****	*****
-0.400	0.2312	0.2283	0.2190	0.0516	-0.7029	*****	*****	*****	*****	*****
-0.600	0.2505	0.2337	0.2144	0.0854	-0.6811	*****	*****	*****	*****	*****
-0.700	0.2698	0.2406	0.2178	0.1021	-0.6487	*****	*****	*****	*****	*****
-0.800	0.2912	*****	0.2294	0.1295	-0.5729	*****	*****	*****	*****	*****
-0.850	*****	0.2752	0.2402	0.1454	-0.5651	*****	*****	*****	*****	*****
-0.900	*****	0.2830	0.2543	0.1682	-0.5287	*****	*****	*****	*****	*****
-0.950	0.2427	0.2486	0.2438	0.1871	-0.1789	*****	*****	*****	*****	*****
-0.975	*****	0.1503	0.1732	0.1517	-0.0348	*****	*****	*****	*****	*****
-1.000	-1.1645	-1.3168	-1.2724	-1.1900	-0.5851	*****	*****	*****	*****	*****

Medium Radius L.E.
 Run No. = 25 , Point No. = 515
 $C_N = 0.511$, $C_m = -0.0904$
 $\alpha = 11.2^\circ$, $M_\infty = 0.829$
 $R_{mac} = 59.9 \times 10^6$

Leading Edge Pressures



x/c_R	starb'd C_p	port C_p
0.10	-0.6740	*****
0.20	-1.1159	-1.1645
0.30	-1.3194	*****
0.40	-1.4091	-1.3168
0.50	-1.4659	*****
0.60	-1.2094	-1.2724
0.70	-0.9185	*****
0.80	-1.1968	-1.1900
0.90	*****	*****
0.95	-0.5359	-0.5851

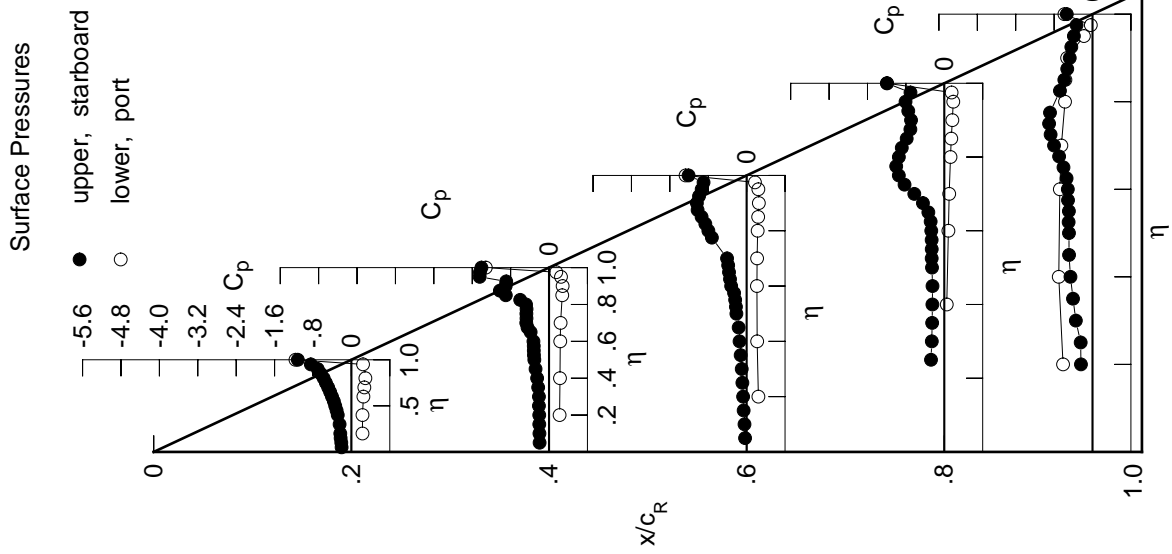
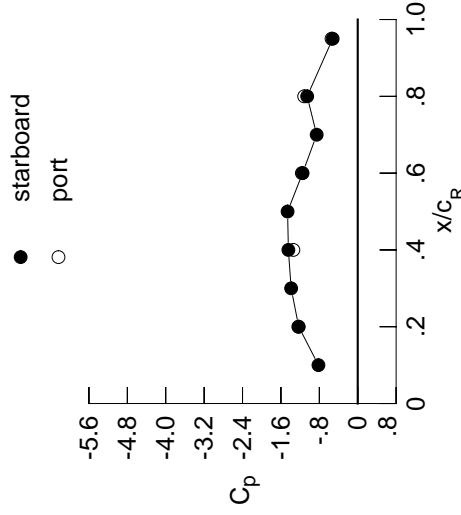

Table G2. Continued.

η	$x/c_R = .2$		$x/c_R = .4$		$x/c_R = .6$		$x/c_R = .8$		$x/c_R = .95$	
	$C_{p,u}$	$C_{p,u}$	$C_{p,u}$	$C_{p,u}$	$C_{p,u}$	$C_{p,u}$	$C_{p,u}$	$C_{p,u}$	$C_{p,u}$	$C_{p,u}$
0.050	-0.2222	-0.2291	-0.0539	*****	*****	*****	*****	*****	*****	*****
0.100	-0.2252	-0.2300	-0.0660	*****	*****	*****	*****	*****	*****	*****
0.150	-0.2438	-0.2350	-0.0837	*****	*****	*****	*****	*****	*****	*****
0.200	-0.2554	-0.2351	-0.0929	*****	*****	*****	*****	*****	*****	*****
0.250	*****	-0.2359	-0.1107	-0.2952	-0.2733	-0.2501	-0.2501	-0.2501	-0.2501	-0.2501
0.300	-0.2722	-0.2439	-0.1284	-0.2799	-0.3611	-0.2952	-0.2733	-0.2733	-0.2733	-0.2733
0.350	*****	-0.2664	-0.1595	-0.2815	-0.3953	-0.2799	-0.3611	-0.2799	-0.3611	-0.3611
0.400	-0.3165	-0.2945	-0.1836	-0.2806	-0.4071	-0.2815	-0.3953	-0.2806	-0.4071	-0.4071
0.450	-0.3427	-0.3391	-0.2024	-0.2733	-0.4007	-0.2806	-0.4071	-0.2733	-0.4007	-0.4007
0.500	-0.3707	-0.3419	-0.2407	-0.2631	-0.4341	-0.2733	-0.4007	-0.2631	-0.4341	-0.4341
0.525	*****	-0.3404	-0.2395	-0.2616	-0.4651	-0.2631	-0.4341	-0.2616	-0.4651	-0.4651
0.550	-0.3983	-0.3441	-0.2392	-0.2544	-0.4742	-0.2616	-0.4651	-0.2544	-0.4742	-0.4742
0.575	*****	-0.3488	-0.2377	-0.2552	-0.5031	-0.2544	-0.4742	-0.2552	-0.5031	-0.5031
0.600	-0.4367	-0.3636	-0.2721	-0.2733	-0.5213	-0.2552	-0.5031	-0.2733	-0.5213	-0.5213
0.625	*****	*****	-0.2860	-0.3233	-0.5926	-0.2733	-0.5213	-0.3233	-0.5926	-0.5926
0.650	-0.4807	-0.4462	-0.3877	-0.4493	-0.7274	-0.3233	-0.5926	-0.4493	-0.7274	-0.7274
0.675	*****	-0.5069	-0.5689	-0.6704	-0.8892	-0.4493	-0.7274	-0.6704	-0.8892	-0.8892
0.700	-0.5276	-0.5218	-0.7351	-0.9123	-1.0481	-0.6704	-0.8892	-0.9123	-1.0481	-1.0481
0.725	*****	-0.5233	*****	-1.0904	-1.1336	-0.9123	-1.0481	-1.0904	-1.1336	-1.1336
0.750	-0.5806	-0.5368	*****	-1.1389	-1.1019	-1.0904	-1.1336	-1.1389	-1.1019	-1.1019
0.775	*****	-0.5096	-0.9674	-1.1351	-0.9291	-1.1389	-1.1019	-1.1351	-0.9291	-0.9291
0.800	-0.6347	-0.5025	-0.9735	-1.0870	*****	-0.9291	-0.9291	-1.0870	*****	*****
0.825	*****	-0.7895	-0.9988	-1.0233	-0.6005	-1.0870	*****	-1.0233	-0.6005	-0.6005
0.850	-0.6946	-1.2125	-1.0276	-0.8859	-0.5192	-1.0233	-0.6005	-0.8859	-0.5192	-0.5192
0.875	*****	-1.3117	-1.0480	-0.7955	-0.4808	-0.8859	-0.5192	-0.7955	-0.4808	-0.4808
0.900	-0.8498	-1.1914	-1.0150	-0.7621	-0.4687	-1.0480	-0.7955	-0.7621	-0.4687	-0.4687
0.925	*****	-1.1611	-0.9531	-0.7365	-0.4682	-0.7621	-0.4687	-0.9531	-0.7365	-0.7365
0.950	-1.2782	-1.3489	-0.9084	-0.7190	-0.4032	-0.7365	-0.4682	-0.9084	-0.7190	-0.7190
0.975	*****	-1.3044	-0.8708	-0.6417	-0.3439	-0.7190	-0.4032	-0.8708	-0.6417	-0.6417
1.000	-1.2293	-1.4449	-1.1488	-1.0530	-0.5222	-0.6417	-0.3439	-1.1488	-1.0530	-1.0530
-0.200	$C_{p,l}$	$C_{p,l}$	$C_{p,l}$	$C_{p,l}$	$C_{p,l}$	$C_{p,l}$	$C_{p,l}$	$C_{p,l}$	$C_{p,l}$	$C_{p,l}$
-0.400	0.2626	0.2468	0.2653	*****	-0.5985	0.2653	*****	-0.5985	0.2653	0.2653
-0.600	0.2641	0.2566	0.2398	0.0691	-0.6922	0.2398	0.0691	-0.6922	0.2398	0.2398
-0.700	0.2840	0.2611	0.2369	0.1038	-0.6702	0.2369	0.1038	-0.6702	0.2369	0.2369
-0.800	0.3015	0.2691	0.2401	0.1203	-0.6357	0.2401	0.1203	-0.6357	0.2401	0.2401
-0.850	0.3192	*****	0.2528	0.1482	-0.5572	0.2528	0.1482	-0.5572	0.2528	0.2528
-0.900	*****	0.3006	0.2620	0.1644	-0.5465	0.2620	0.1644	-0.5465	0.2620	0.2620
-0.950	*****	0.3023	0.2715	0.1847	-0.5072	0.2715	0.1847	-0.5072	0.2715	0.2715
-0.975	0.2415	0.2532	0.2495	0.1949	-0.1676	0.2495	0.1949	-0.1676	0.2495	0.2495
-1.000	0.2415	0.1371	0.1656	0.1466	-0.0325	0.1656	0.1466	-0.0325	0.1656	0.1656
-1.000	-1.2364	-1.3406	-1.1637	-1.1160	-0.5459	-1.1637	-1.1160	-0.5459	-1.1637	-1.1637

Medium Radius L.E.
 Run No. = 25 , Point No. = 516
 $C_N = 0.574$, $C_m = -0.1003$
 $\alpha = 12.3^\circ$, $M_\infty = 0.827$
 $R_{mac} = 59.7 \times 10^6$

Leading Edge Pressures



x/c_R	starb'd C_p	port C_p
0.10	-0.8182	*****
0.20	-1.2293	-1.2364
0.30	-1.3872	*****
0.40	-1.4449	-1.3406
0.50	-1.4612	*****
0.60	-1.1488	-1.1637
0.70	-0.8552	*****
0.80	-1.0530	-1.1160
0.90	*****	*****
0.95	-0.5222	-0.5459

Surface Pressures

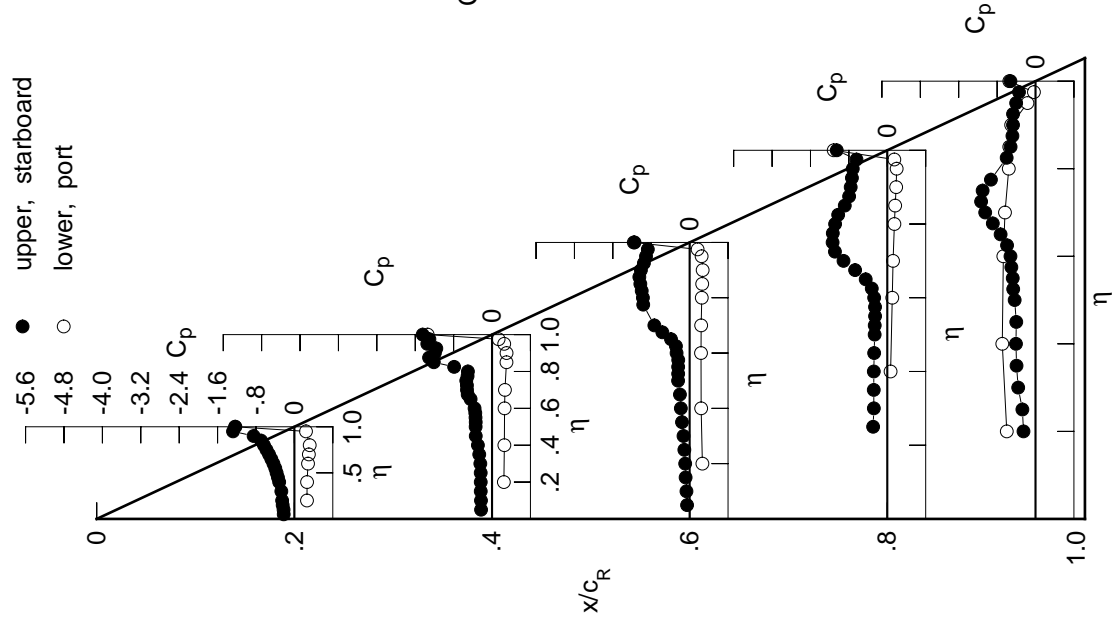
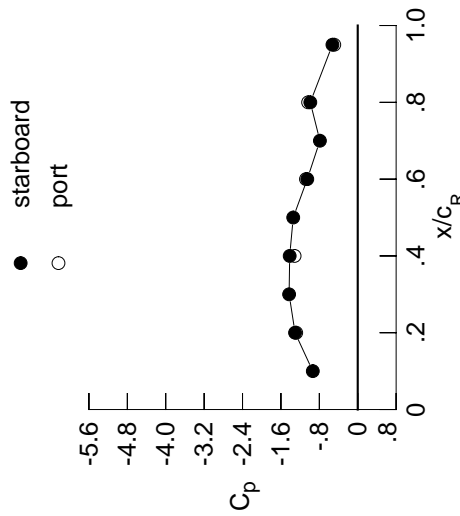

Table G2. Continued.

η	$x/c_R = .2$		$x/c_R = .4$		$x/c_R = .6$		$x/c_R = .8$		$x/c_R = .95$	
	$C_{p,u}$	$C_{p,u}$	$C_{p,u}$	$C_{p,u}$	$C_{p,u}$	$C_{p,u}$	$C_{p,u}$	$C_{p,u}$	$C_{p,u}$	$C_{p,u}$
0.050	-0.2384	-0.2656	-0.0714	*****	*****	*****	*****	*****	*****	*****
0.100	-0.2384	-0.2664	-0.0828	*****	*****	*****	*****	*****	*****	*****
0.150	-0.2574	-0.2688	-0.0995	*****	*****	*****	*****	*****	*****	*****
0.200	-0.2739	-0.2665	-0.1106	*****	*****	*****	*****	*****	*****	-0.2403
0.250	*****	-0.2700	-0.1295	-0.3143	-0.3143	-0.2583	*****	*****	*****	*****
0.300	-0.3068	-0.2854	-0.1497	-0.3017	-0.3412	*****	*****	*****	*****	*****
0.350	*****	-0.3119	-0.1817	-0.2976	-0.3696	*****	*****	*****	*****	*****
0.400	-0.3558	-0.3332	-0.1934	-0.2792	-0.4172	*****	*****	*****	*****	*****
0.450	-0.3747	-0.3823	-0.1794	-0.2664	-0.4997	*****	*****	*****	*****	*****
0.500	-0.3979	-0.3924	-0.1900	-0.2527	-0.5500	*****	*****	*****	*****	*****
0.525	*****	-0.3841	-0.1881	-0.2523	-0.5731	*****	*****	*****	*****	*****
0.550	-0.4244	-0.3846	-0.2006	-0.2597	-0.5744	*****	*****	*****	*****	*****
0.575	*****	-0.3842	-0.2293	-0.2944	-0.6184	*****	*****	*****	*****	*****
0.600	-0.4624	-0.3954	-0.3882	-0.3723	-0.6791	*****	*****	*****	*****	*****
0.625	*****	*****	-0.5606	-0.5160	-0.8049	*****	*****	*****	*****	*****
0.650	-0.5045	-0.5554	-0.8076	-0.7363	-0.9719	*****	*****	*****	*****	*****
0.675	*****	-0.7092	-0.9972	-0.9865	-1.1242	*****	*****	*****	*****	*****
0.700	-0.5559	-0.8076	-1.0937	-1.1875	-1.2516	*****	*****	*****	*****	*****
0.725	*****	-0.8611	*****	-1.3148	-1.0955	*****	*****	*****	*****	*****
0.750	-0.6018	-0.9262	*****	-1.3186	-0.8695	*****	*****	*****	*****	*****
0.775	*****	-1.0021	-1.0662	-1.1815	-0.7417	*****	*****	*****	*****	*****
0.800	-0.6673	-1.0657	-1.0630	-1.0495	*****	*****	*****	*****	*****	*****
0.825	*****	-1.0819	-1.0805	-0.9353	-0.5536	*****	*****	*****	*****	*****
0.850	-1.0179	-1.0952	-1.0808	-0.8491	-0.5098	*****	*****	*****	*****	*****
0.875	*****	-1.1351	-1.0390	-0.8137	-0.4996	*****	*****	*****	*****	*****
0.900	-1.2539	-1.1036	-0.9567	-0.7741	-0.5034	*****	*****	*****	*****	*****
0.925	*****	-1.0940	-0.8924	-0.7158	-0.4991	*****	*****	*****	*****	*****
0.950	-1.3443	-1.2930	-0.8539	-0.7086	-0.4294	*****	*****	*****	*****	*****
0.975	*****	-1.2048	-0.8195	-0.6417	-0.3675	*****	*****	*****	*****	*****
1.000	-1.3057	-1.4176	-1.0511	-0.9883	-0.5269	*****	*****	*****	*****	*****
-0.200	$C_{p,l}$	$C_{p,l}$	$C_{p,l}$	$C_{p,l}$	$C_{p,l}$	$C_{p,l}$	$C_{p,l}$	$C_{p,l}$	$C_{p,l}$	$C_{p,l}$
-0.400	0.2984	0.2778	0.2900	*****	*****	*****	*****	*****	*****	-0.5899
-0.600	0.2953	0.2871	0.2646	0.0903	-0.6762	*****	*****	*****	*****	*****
-0.700	0.3146	0.2923	0.2622	0.1248	-0.6545	*****	*****	*****	*****	*****
-0.800	0.3305	0.2944	0.2651	0.1423	-0.6209	*****	*****	*****	*****	*****
-0.850	0.3430	*****	0.2715	0.1698	-0.5412	*****	*****	*****	*****	*****
-0.900	*****	0.3209	0.2793	0.1790	-0.5353	*****	*****	*****	*****	*****
-0.950	0.2378	0.2544	0.2496	0.1985	-0.1602	*****	*****	*****	*****	*****
-0.975	*****	0.1228	0.1519	0.1370	-0.0338	*****	*****	*****	*****	*****
-1.000	-1.2816	-1.3149	-1.0783	-1.0338	-0.4885	*****	*****	*****	*****	*****

Medium Radius L.E.
 Run No. = 25 , Point No. = 517
 $C_N = 0.637$, $C_m = -0.1101$
 $\alpha = 13.4^\circ$, $M_\infty = 0.827$
 $R_{mac} = 59.7 \times 10^6$

Leading Edge Pressures



x/c_R	starb'd C_p	port C_p
0.10	-0.9364	*****
0.20	-1.3057	-1.2816
0.30	-1.4296	*****
0.40	-1.4176	-1.3149
0.50	-1.3438	*****
0.60	-1.0511	-1.0783
0.70	-0.7877	*****
0.80	-0.9883	-1.0338
0.90	*****	*****
0.95	-0.5269	-0.4885

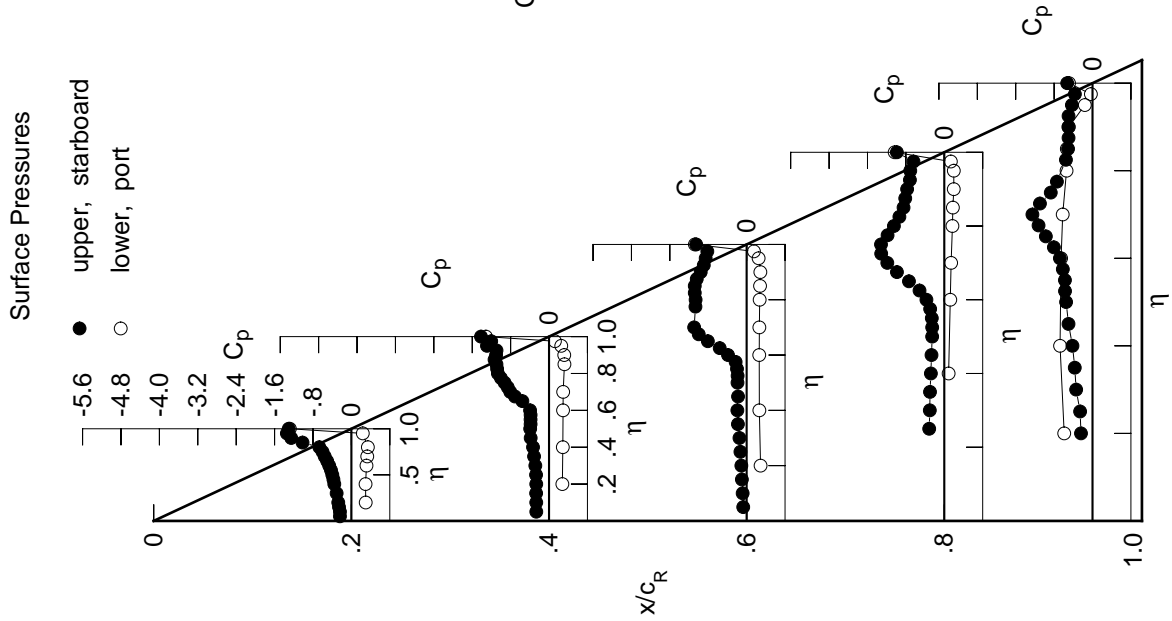

Table G2. Continued.

η	$x/c_R = .2$		$x/c_R = .4$		$x/c_R = .6$		$x/c_R = .8$		$x/c_R = .95$	
	$C_{p,u}$	$C_{p,u}$	$C_{p,u}$	$C_{p,u}$	$C_{p,u}$	$C_{p,u}$	$C_{p,u}$	$C_{p,u}$	$C_{p,u}$	$C_{p,u}$
0.050	-0.2538	-0.2950	-0.0856	*****	*****	*****	*****	*****	*****	*****
0.100	-0.2495	-0.2949	-0.0964	*****	*****	*****	*****	*****	*****	*****
0.150	-0.2676	-0.2987	-0.1108	*****	*****	*****	*****	*****	*****	*****
0.200	-0.2827	-0.2898	-0.1232	*****	*****	*****	*****	*****	*****	*****
0.250	*****	-0.3021	-0.1518	-0.3235	-0.3176	*****	*****	*****	*****	*****
0.300	-0.3535	-0.3233	-0.1645	-0.3091	-0.3394	*****	*****	*****	*****	*****
0.350	*****	-0.3492	-0.1753	-0.2970	-0.3705	*****	*****	*****	*****	*****
0.400	-0.3925	-0.3422	-0.1786	-0.2776	-0.4591	*****	*****	*****	*****	*****
0.450	-0.4049	-0.3419	-0.1618	-0.2696	-0.5247	*****	*****	*****	*****	*****
0.500	-0.4221	-0.3570	-0.2013	-0.2725	-0.5477	*****	*****	*****	*****	*****
0.525	*****	-0.4084	-0.2223	-0.2869	-0.5674	*****	*****	*****	*****	*****
0.550	-0.4454	-0.4614	-0.2756	-0.3231	-0.5823	*****	*****	*****	*****	*****
0.575	*****	-0.5166	-0.3701	-0.3983	-0.6533	*****	*****	*****	*****	*****
0.600	-0.4861	-0.6026	-0.6146	-0.5253	-0.7530	*****	*****	*****	*****	*****
0.625	*****	*****	-0.8361	-0.7075	-0.9032	*****	*****	*****	*****	*****
0.650	-0.5449	-0.8588	-1.0690	-0.9285	-1.0784	*****	*****	*****	*****	*****
0.675	*****	-0.9713	-1.2363	-1.1444	-1.1422	*****	*****	*****	*****	*****
0.700	-0.6627	-1.0569	-1.3008	-1.3086	-0.7957	*****	*****	*****	*****	*****
0.725	*****	-1.1176	*****	-1.4216	-0.7446	*****	*****	*****	*****	*****
0.750	-0.6854	-1.1635	*****	-1.4134	-0.6975	*****	*****	*****	*****	*****
0.775	*****	-1.1740	-1.1804	-1.1216	-0.6415	*****	*****	*****	*****	*****
0.800	-0.6444	-1.1596	-1.1683	-0.9728	*****	*****	*****	*****	*****	*****
0.825	*****	-1.1399	-1.1443	-0.8806	-0.5661	*****	*****	*****	*****	*****
0.850	-1.2887	-1.1425	-1.0805	-0.8372	-0.5415	*****	*****	*****	*****	*****
0.875	*****	-1.1578	-0.9954	-0.8267	-0.5476	*****	*****	*****	*****	*****
0.900	-1.4309	-1.1180	-0.9166	-0.8057	-0.5193	*****	*****	*****	*****	*****
0.925	*****	-1.0915	-0.8716	-0.7050	-0.5020	*****	*****	*****	*****	*****
0.950	-1.4382	-1.2267	-0.8334	-0.7320	-0.4313	*****	*****	*****	*****	*****
0.975	*****	-1.1396	-0.8004	-0.6758	-0.3635	*****	*****	*****	*****	*****
1.000	-1.3844	-1.3363	-1.0089	-0.9661	-0.4929	*****	*****	*****	*****	*****
-0.200	$C_{p,l}$	$C_{p,l}$	$C_{p,l}$	$C_{p,l}$	$C_{p,l}$	$C_{p,l}$	$C_{p,l}$	$C_{p,l}$	$C_{p,l}$	$C_{p,l}$
-0.400	0.3354	0.3102	0.3161	*****	*****	*****	*****	*****	*****	*****
-0.600	0.3242	0.3189	0.2919	1.140	-0.6560	*****	*****	*****	*****	*****
-0.700	0.3433	0.3242	0.2892	1.488	-0.6361	*****	*****	*****	*****	*****
-0.800	0.3571	0.3180	0.2921	1.658	-0.6012	*****	*****	*****	*****	*****
-0.850	0.3645	*****	0.2890	1.916	-0.5198	*****	*****	*****	*****	*****
-0.900	*****	0.3389	0.2951	1.917	-0.5245	*****	*****	*****	*****	*****
-0.950	0.2302	0.2520	0.2489	1.980	-0.1557	*****	*****	*****	*****	*****
-0.975	*****	0.1049	0.1392	1.234	-0.0403	*****	*****	*****	*****	*****
-1.000	-1.3304	-1.2372	-0.9958	-0.9801	-0.5017	*****	*****	*****	*****	*****

Medium Radius L.E.
 Run No. = 25 , Point No. = 518
 $C_N = 0.695$, $C_m = -0.1169$
 $\alpha = 14.4^\circ$, $M_\infty = 0.827$
 $R_{mac} = 59.7 \times 10^6$

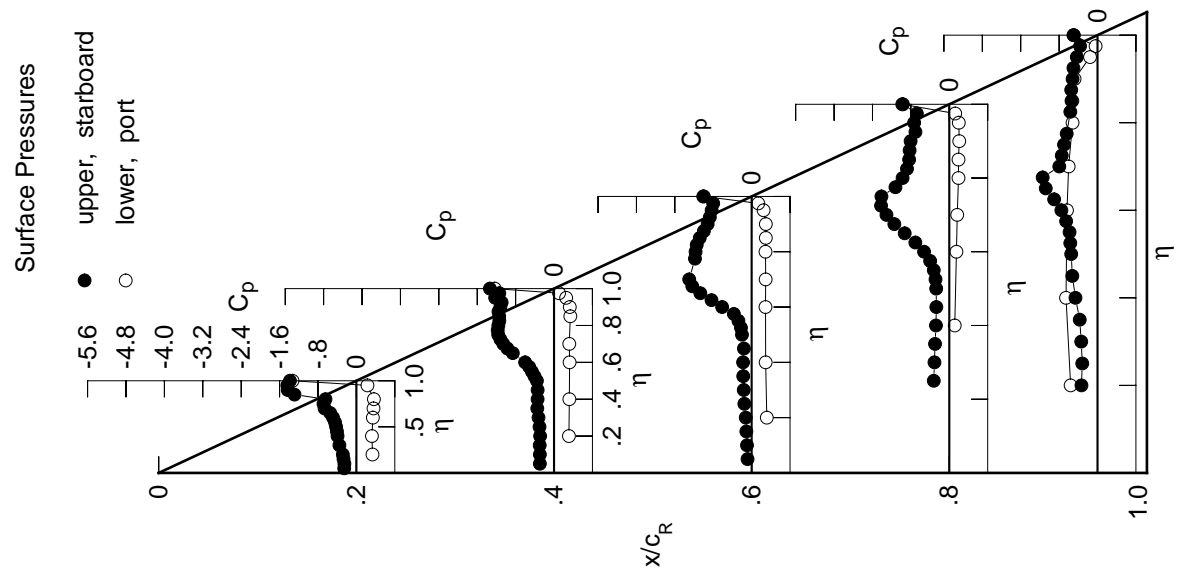
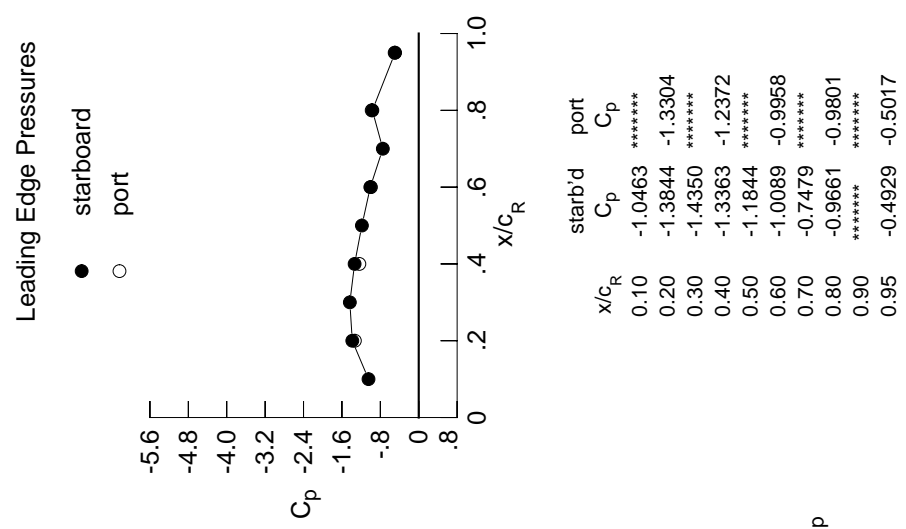
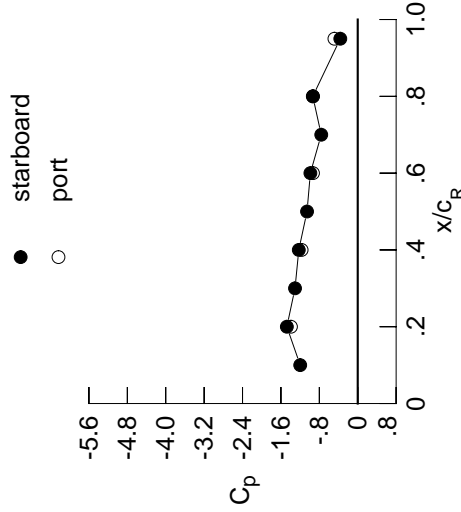

Table G2. Continued.

η	$x/c_R = .2$		$x/c_R = .4$		$x/c_R = .6$		$x/c_R = .8$		$x/c_R = .95$	
	$C_{p,u}$	$C_{p,u}$	$C_{p,u}$	$C_{p,u}$	$C_{p,u}$	$C_{p,u}$	$C_{p,u}$	$C_{p,u}$	$C_{p,u}$	$C_{p,u}$
0.050	-0.3224	-0.3745	-0.1262	*****	*****	*****	*****	*****	*****	*****
0.100	-0.3146	-0.3769	-0.1378	*****	*****	*****	*****	*****	*****	*****
0.150	-0.3282	-0.3714	-0.1507	*****	*****	*****	*****	*****	*****	*****
0.200	-0.3376	-0.3734	-0.1673	*****	*****	*****	*****	*****	*****	-0.4186
0.250	*****	-0.3908	-0.1904	-0.3724	-0.4052	*****	*****	*****	*****	-0.4052
0.300	-0.4424	-0.4002	-0.2044	-0.3561	-0.4397	*****	*****	*****	*****	-0.4397
0.350	*****	-0.4137	-0.2187	-0.3471	-0.4659	*****	*****	*****	*****	-0.4659
0.400	-0.4624	-0.4157	-0.2349	-0.3356	-0.5284	*****	*****	*****	*****	-0.5284
0.450	-0.4704	-0.4284	-0.2401	-0.3465	-0.5785	*****	*****	*****	*****	-0.5785
0.500	-0.4981	-0.4580	-0.3480	-0.4014	-0.6324	*****	*****	*****	*****	-0.6324
0.525	*****	-0.5239	-0.4457	-0.4620	-0.6941	*****	*****	*****	*****	-0.6941
0.550	-0.5438	-0.6373	-0.5933	-0.5998	-0.7602	*****	*****	*****	*****	-0.7602
0.575	*****	-0.8096	-0.7670	-0.6988	-0.8825	*****	*****	*****	*****	-0.8825
0.600	-0.6480	-1.0093	-1.0160	-0.8670	-1.0055	*****	*****	*****	*****	-1.0055
0.625	*****	*****	-1.1931	-1.0438	-0.7973	*****	*****	*****	*****	-0.7973
0.650	-0.7182	-1.3593	-1.3455	-1.2154	-0.6052	*****	*****	*****	*****	-0.6052
0.675	*****	-1.4303	-1.4642	-1.3635	-0.5635	*****	*****	*****	*****	-0.5635
0.700	-0.7926	-1.4623	-1.5201	-1.2003	-0.5285	*****	*****	*****	*****	-0.5285
0.725	*****	-1.4914	*****	-1.0509	-0.4908	*****	*****	*****	*****	-0.4908
0.750	-1.0591	-1.4801	*****	-1.0310	-0.4608	*****	*****	*****	*****	-0.4608
0.775	*****	-1.3897	-1.2993	-1.0534	-0.4388	*****	*****	*****	*****	-0.4388
0.800	-1.3251	-1.3229	-1.2332	-1.0930	*****	*****	*****	*****	*****	-0.4388
0.825	*****	-1.2513	-1.1018	-1.1032	-0.4532	*****	*****	*****	*****	-0.4532
0.850	-1.4760	-1.1944	-1.0294	-1.1064	-0.4522	*****	*****	*****	*****	-0.4522
0.875	*****	-1.1762	-1.0028	-0.9909	-0.4760	*****	*****	*****	*****	-0.4760
0.900	-1.4303	-1.1681	-0.9997	-0.8377	-0.4884	*****	*****	*****	*****	-0.4884
0.925	*****	-1.1547	-0.9352	-0.7675	-0.4687	*****	*****	*****	*****	-0.4687
0.950	-1.3863	-1.1445	-0.8614	-0.8172	-0.3951	*****	*****	*****	*****	-0.3951
0.975	*****	-1.0324	-0.8368	-0.7543	-0.3234	*****	*****	*****	*****	-0.3234
1.000	-1.4766	-1.2280	-0.9867	-0.9363	-0.3631	*****	*****	*****	*****	-0.3631
-0.200	$C_{p,l}$	$C_{p,l}$	$C_{p,l}$	$C_{p,l}$	$C_{p,l}$	$C_{p,l}$	$C_{p,l}$	$C_{p,l}$	$C_{p,l}$	$C_{p,l}$
-0.400	0.3909	0.3550	0.3490	*****	*****	*****	*****	*****	*****	-0.5531
-0.600	0.3828	0.3642	0.3246	0.1408	-0.6418	*****	*****	*****	*****	-0.6418
-0.700	0.3997	0.3679	0.3220	0.1745	-0.6220	*****	*****	*****	*****	-0.6220
-0.800	0.4088	0.3630	0.3244	0.1897	-0.5852	*****	*****	*****	*****	-0.5852
-0.850	0.4055	*****	0.3205	0.2137	-0.5010	*****	*****	*****	*****	-0.5010
-0.900	*****	0.3711	0.3230	0.2149	-0.4992	*****	*****	*****	*****	-0.4992
-0.950	*****	0.3468	0.3127	0.2235	-0.4478	*****	*****	*****	*****	-0.4478
-0.975	0.2208	0.2457	0.2402	0.1927	-0.1447	*****	*****	*****	*****	-0.1447
-1.000	*****	0.0718	0.1035	0.0916	-0.0536	*****	*****	*****	*****	-0.0536
-1.000	-1.3910	-1.1686	-0.9322	-0.9311	-0.4858	*****	*****	*****	*****	-0.4858

Medium Radius L.E.
 Run No. = 25 , Point No. = 519
 $C_N = 0.797$, $C_m = -0.1232$
 $\alpha = 16.5^\circ$, $M_\infty = 0.830$
 $R_{mac} = 59.7 \times 10^6$

Leading Edge Pressures



x/c_R	starb'd C_p	port C_p
0.10	-1.1982	*****
0.20	-1.4766	-1.3910
0.30	-1.3067	*****
0.40	-1.2280	-1.1686
0.50	-1.0563	*****
0.60	-0.9867	-0.9322
0.70	-0.7603	*****
0.80	-0.9363	-0.9311
0.90	*****	*****
0.95	-0.3631	-0.4858

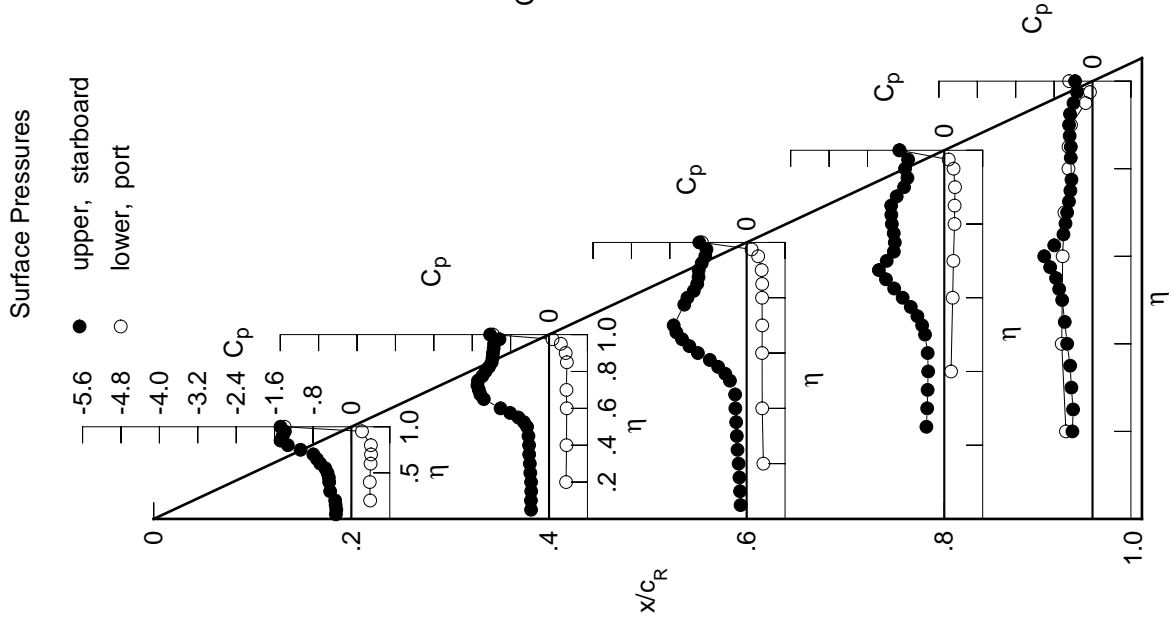

Table G2. Continued.

η	x/c_R .2	x/c_R .4	x/c_R .6	x/c_R .8	x/c_R .95
	$C_{p,u}$	$C_{p,u}$	$C_{p,u}$	$C_{p,u}$	$C_{p,u}$
0.050	-0.4099	-0.4465	-0.1218	*****	*****
0.100	-0.4011	-0.4440	-0.1316	*****	*****
0.150	-0.4078	-0.4379	-0.1431	*****	*****
0.200	-0.4578	-0.4563	-0.1663	*****	-0.7065
0.250	*****	-0.4533	-0.1768	-0.2067	-0.7183
0.300	-0.4498	-0.4497	-0.1870	-0.1758	-0.7202
0.350	*****	-0.4519	-0.2082	-0.1608	-0.7412
0.400	-0.4637	-0.4584	-0.2450	-0.1325	-0.7569
0.450	-0.4823	-0.5127	-0.3068	-0.1585	-0.7534
0.500	-0.5661	-0.6724	-0.5318	-0.2568	-0.7129
0.525	*****	-0.8474	-0.6948	-0.3453	-0.7282
0.550	-0.7425	-1.0622	-0.8812	-0.4631	-0.6956
0.575	*****	-1.2622	-1.0606	-0.6094	-0.7136
0.600	-1.1079	-1.4190	-1.2598	-0.7584	-0.7048
0.625	*****	*****	-1.3847	-0.8409	-0.7034
0.650	-1.3458	-1.6227	-1.4938	-0.6871	-0.7023
0.675	*****	-1.6565	-1.5793	-0.5874	-0.6783
0.700	-1.2523	-1.6333	-1.3951	-0.5516	-0.6696
0.725	*****	-1.5583	*****	-0.5264	-0.6600
0.750	-1.2615	-1.5144	*****	-0.5050	-0.6440
0.775	*****	-1.4239	-1.2485	-0.5040	-0.6255
0.800	-1.4217	-1.3363	-1.2167	-0.5157	*****
0.825	*****	-1.2730	-1.1944	-0.5210	-0.5877
0.850	-1.4850	-1.2322	-1.1728	-0.5478	-0.5519
0.875	*****	-1.2117	-1.1302	-0.5407	-0.5349
0.900	-1.3303	-1.1877	-1.0087	-0.5376	-0.5144
0.925	*****	-1.1663	-0.9185	-0.5477	-0.5065
0.950	-1.3557	-1.1459	-0.8842	-0.5691	-0.4541
0.975	*****	-1.0659	-0.8664	-0.5400	-0.4242
1.000	-1.5177	-1.1957	-0.9602	-0.6335	-0.5257
	$C_{p,l}$	$C_{p,l}$	$C_{p,l}$	$C_{p,l}$	$C_{p,l}$
-0.200	0.4402	0.3925	0.3751	*****	-0.5777
-0.400	0.4404	0.4018	0.3507	0.1557	-0.6520
-0.600	0.4552	0.4028	0.3459	0.1883	-0.6237
-0.700	0.4590	0.4058	0.3486	0.2044	-0.5824
-0.800	0.4446	*****	0.3494	0.2279	-0.4940
-0.850	*****	0.3998	0.3467	0.2355	-0.4769
-0.900	*****	0.3619	0.3253	0.2372	-0.4215
-0.950	0.2114	0.2361	0.2275	0.1846	-0.1313
-0.975	*****	0.0364	0.0651	0.0577	-0.0546
-1.000	-1.4120	-1.1538	-0.9725	-0.9855	-0.4054

Medium Radius L.E.
 Run No. = 25 , Point No. = 520
 $C_N = 0.840$, $C_m = -0.1144$
 $\alpha = 18.5^\circ$, $M_\infty = 0.831$
 $R_{mac} = 59.7 \times 10^6$

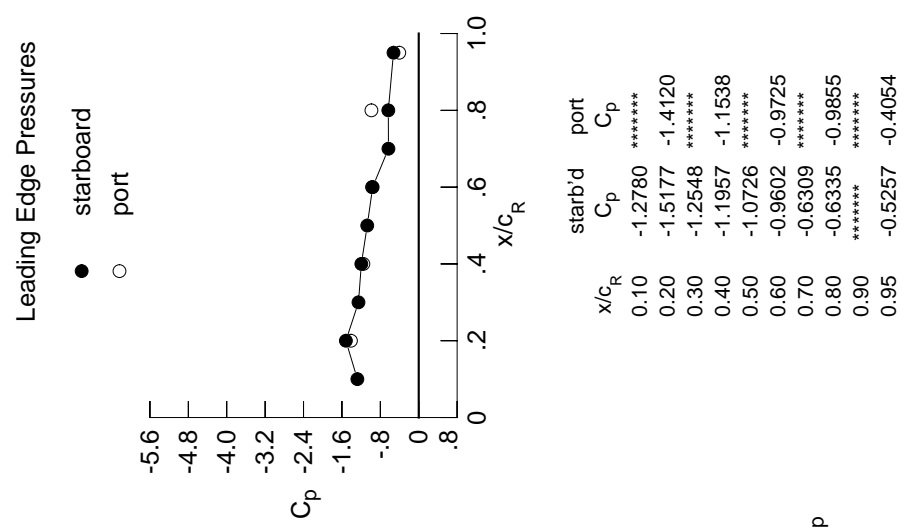

Table G2. Continued.

η	x/c_R .2	x/c_R .4	x/c_R .6	x/c_R .8	x/c_R .95
	$C_{p,u}$	$C_{p,u}$	$C_{p,u}$	$C_{p,u}$	$C_{p,u}$
0.050	-0.4622	-0.5322	-0.1056	*****	*****
0.100	-0.4535	-0.5290	-0.1122	*****	*****
0.150	-0.4953	-0.5307	-0.1227	*****	*****
0.200	-0.4998	-0.5459	-0.1382	*****	-0.5417
0.250	*****	-0.5484	-0.1589	-0.4559	-0.5612
0.300	-0.4949	-0.5536	-0.1782	-0.4672	-0.6073
0.350	*****	-0.5751	-0.2226	-0.5189	-0.6626
0.400	-0.5197	-0.6275	-0.3098	-0.5670	-0.7309
0.450	-0.5366	-0.7742	-0.4505	-0.6804	-0.7607
0.500	-0.6358	-1.0168	-0.7436	-0.8098	-0.7225
0.525	*****	-1.1704	-0.9128	-0.8592	-0.7341
0.550	-1.0573	-1.3338	-1.0769	-0.8899	-0.6973
0.575	*****	-1.4621	-1.2228	-0.9053	-0.7087
0.600	-1.5415	-1.5605	-1.3776	-0.9189	-0.7001
0.625	*****	*****	-1.4741	-0.9242	-0.7018
0.650	-1.7560	-1.7237	-1.3614	-0.8979	-0.7007
0.675	*****	-1.7645	-1.1938	-0.8564	-0.6796
0.700	-1.5770	-1.6381	-1.1597	-0.8071	-0.6679
0.725	*****	-1.5740	*****	-0.7747	-0.6554
0.750	-1.4566	-1.5478	*****	-0.7366	-0.6365
0.775	*****	-1.5186	-1.1361	-0.7274	-0.6173
0.800	-1.5331	-1.4477	-1.1897	-0.7275	*****
0.825	*****	-1.3716	-1.2635	-0.7177	-0.5790
0.850	-1.4990	-1.3218	-1.1599	-0.7437	-0.5480
0.875	*****	-1.2687	-0.9979	-0.7608	-0.5220
0.900	-1.3096	-1.2199	-0.9001	-0.7939	-0.4886
0.925	*****	-1.1994	-0.8849	-0.8451	-0.4607
0.950	-1.2650	-1.2046	-0.8714	-0.8831	-0.4198
0.975	*****	-1.1614	-0.8428	-0.8386	-0.3880
1.000	-1.5246	-1.2576	-0.8854	-0.9262	-0.4180
	$C_{p,l}$	$C_{p,l}$	$C_{p,l}$	$C_{p,l}$	$C_{p,l}$
-0.200	0.4951	0.4389	0.4097	*****	-0.5577
-0.400	0.4962	0.4469	0.3859	0.1872	-0.6289
-0.600	0.5065	0.4450	0.3802	0.2173	-0.6010
-0.700	0.5033	0.4463	0.3808	0.2322	-0.5587
-0.800	0.4775	*****	0.3780	0.2520	-0.4710
-0.850	*****	0.4241	0.3691	0.2571	-0.4528
-0.900	*****	0.3714	0.3352	0.2504	-0.3978
-0.950	0.1946	0.2197	0.2087	0.1747	-0.1289
-0.975	*****	-0.0059	0.0192	0.0222	-0.0784
-1.000	-1.4001	-1.2382	-1.0474	-1.0189	-0.4510

Medium Radius L.E.
 Run No. = 25, Point No. = 521
 $C_N = 0.969$, $C_m = -0.1462$
 $\alpha = 20.6^\circ$, $M_\infty = 0.831$
 $R_{mac} = 59.8 \times 10^6$

Leading Edge Pressures

● starboard
 ○ port

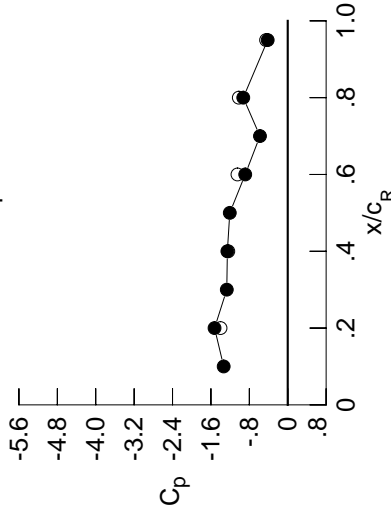

x/c_R	starb'd C_p	port C_p
0.10	-1.3341	*****
0.20	-1.5246	-1.4001
0.30	-1.2697	*****
0.40	-1.2576	-1.2382
0.50	-1.2072	*****
0.60	-0.8854	-1.0474
0.70	-0.5786	*****
0.80	-0.9262	-1.0189
0.90	*****	*****
0.95	-0.4180	-0.4510

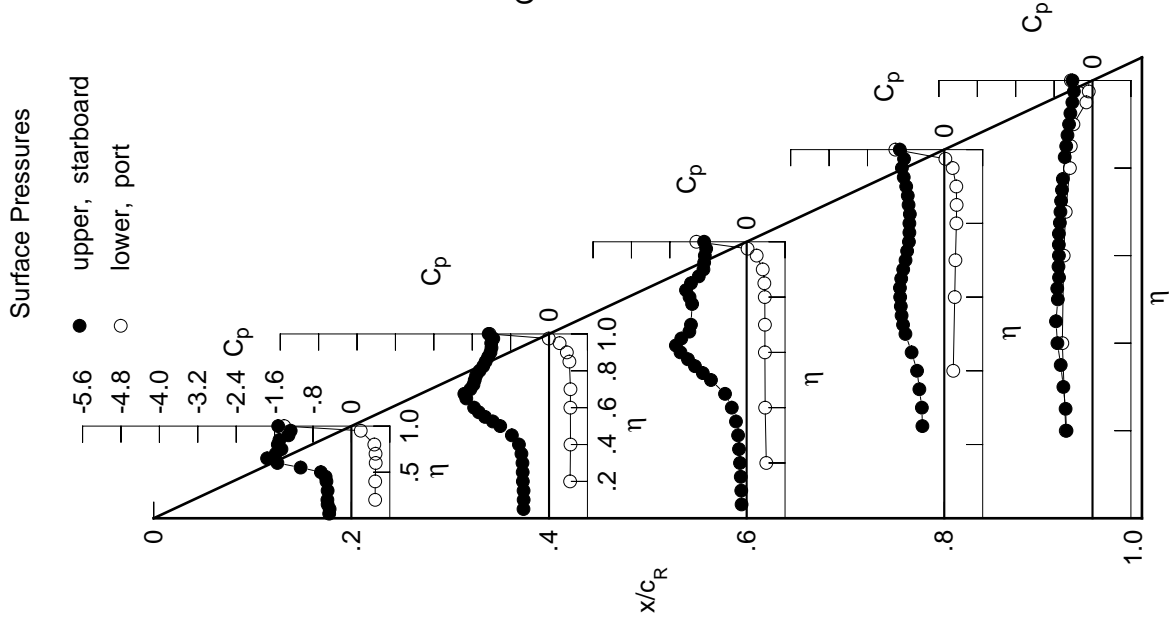
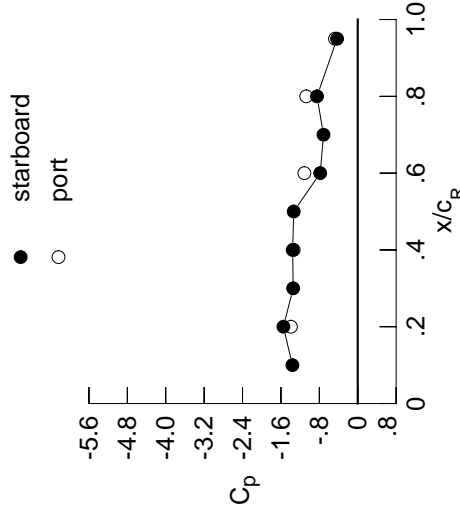

Table G2. Continued.

η	$x/c_R = .2$		$x/c_R = .4$		$x/c_R = .6$		$x/c_R = .8$		$x/c_R = .95$	
	$C_{p,u}$	$C_{p,l}$	$C_{p,u}$	$C_{p,l}$	$C_{p,u}$	$C_{p,l}$	$C_{p,u}$	$C_{p,l}$	$C_{p,u}$	$C_{p,l}$
0.050	-0.5379	-0.5901	-0.1220	*****	*****	*****	*****	*****	*****	*****
0.100	-0.5307	-0.5926	-0.1262	*****	*****	*****	*****	*****	*****	*****
0.150	-0.5688	-0.5928	-0.1339	*****	*****	*****	*****	*****	*****	*****
0.200	-0.5685	-0.6114	-0.1449	*****	*****	*****	*****	*****	*****	*****
0.250	*****	-0.6351	-0.1727	-0.6771	-0.6771	-0.6771	-0.6771	-0.6771	-0.6771	-0.6771
0.300	-0.5662	-0.6576	-0.2107	-0.7057	-0.7057	-0.7057	-0.7057	-0.7057	-0.7057	-0.7057
0.350	*****	-0.7170	-0.2954	-0.7719	-0.7719	-0.7719	-0.7719	-0.7719	-0.7719	-0.7719
0.400	-0.6120	-0.8206	-0.4414	-0.8176	-0.8176	-0.8176	-0.8176	-0.8176	-0.8176	-0.8176
0.450	-0.7239	-1.0081	-0.6286	-0.8903	-0.8903	-0.8903	-0.8903	-0.8903	-0.8903	-0.8903
0.500	-1.0315	-1.2283	-0.9449	-0.9365	-0.9365	-0.9365	-0.9365	-0.9365	-0.9365	-0.9365
0.525	*****	-1.3523	-1.0995	-0.9493	-0.9493	-0.9493	-0.9493	-0.9493	-0.9493	-0.9493
0.550	-1.4625	-1.4880	-1.2343	-0.9502	-0.9502	-0.9502	-0.9502	-0.9502	-0.9502	-0.9502
0.575	*****	-1.5861	-1.3541	-0.9585	-0.9585	-0.9585	-0.9585	-0.9585	-0.9585	-0.9585
0.600	-1.7474	-1.6702	-1.4810	-0.9741	-0.9741	-0.9741	-0.9741	-0.9741	-0.9741	-0.9741
0.625	*****	*****	-1.3819	-0.9731	-0.9731	-0.9731	-0.9731	-0.9731	-0.9731	-0.9731
0.650	-1.8805	-1.6046	-1.1724	-0.9468	-0.9468	-0.9468	-0.9468	-0.9468	-0.9468	-0.9468
0.675	*****	-1.5399	-1.1235	-0.9219	-0.9219	-0.9219	-0.9219	-0.9219	-0.9219	-0.9219
0.700	-1.7318	-1.5126	-1.0990	-0.8923	-0.8923	-0.8923	-0.8923	-0.8923	-0.8923	-0.8923
0.725	*****	-1.4971	*****	-0.8689	-0.8689	-0.8689	-0.8689	-0.8689	-0.8689	-0.8689
0.750	-1.6217	-1.4808	*****	-0.8365	-0.8365	-0.8365	-0.8365	-0.8365	-0.8365	-0.8365
0.775	*****	-1.4807	-1.0578	-0.8286	-0.8286	-0.8286	-0.8286	-0.8286	-0.8286	-0.8286
0.800	-1.4715	-1.5181	-1.0933	-0.8266	-0.8266	-0.8266	-0.8266	-0.8266	-0.8266	-0.8266
0.825	*****	-1.4933	-1.0966	-0.8214	-0.8214	-0.8214	-0.8214	-0.8214	-0.8214	-0.8214
0.850	-1.4546	-1.4020	-0.9949	-0.8376	-0.8376	-0.8376	-0.8376	-0.8376	-0.8376	-0.8376
0.875	*****	-1.3367	-0.9026	-0.8395	-0.8395	-0.8395	-0.8395	-0.8395	-0.8395	-0.8395
0.900	-1.3522	-1.3184	-0.8446	-0.8441	-0.8441	-0.8441	-0.8441	-0.8441	-0.8441	-0.8441
0.925	*****	-1.3175	-0.8201	-0.8468	-0.8468	-0.8468	-0.8468	-0.8468	-0.8468	-0.8468
0.950	-1.3046	-1.3383	-0.7980	-0.8499	-0.8499	-0.8499	-0.8499	-0.8499	-0.8499	-0.8499
0.975	*****	-1.3068	-0.7622	-0.8240	-0.8240	-0.8240	-0.8240	-0.8240	-0.8240	-0.8240
1.000	-1.5480	-1.3554	-0.7814	-0.8487	-0.8487	-0.8487	-0.8487	-0.8487	-0.8487	-0.8487
-0.200	$C_{p,l}$	0.5515	0.4878	0.4492	*****	*****	*****	*****	*****	*****
-0.400	$C_{p,l}$	0.5517	0.4947	0.4246	0.2228	0.2228	0.2228	0.2228	0.2228	0.2228
-0.600	$C_{p,l}$	0.5571	0.4900	0.4182	0.2498	0.2498	0.2498	0.2498	0.2498	0.2498
-0.700	$C_{p,l}$	0.5468	0.4870	0.4170	0.2641	0.2641	0.2641	0.2641	0.2641	0.2641
-0.800	$C_{p,l}$	0.5078	*****	0.4079	0.2798	0.2798	0.2798	0.2798	0.2798	0.2798
-0.850	$C_{p,l}$	*****	0.4472	0.3929	0.2799	0.2799	0.2799	0.2799	0.2799	0.2799
-0.900	$C_{p,l}$	*****	0.3794	0.3461	0.2642	0.2642	0.2642	0.2642	0.2642	0.2642
-0.950	$C_{p,l}$	0.1763	0.2026	0.1947	0.1657	0.1657	0.1657	0.1657	0.1657	0.1657
-0.975	$C_{p,l}$	*****	-0.0466	-0.0177	-0.0105	-0.0105	-0.0105	-0.0105	-0.0105	-0.0105
-1.000	$C_{p,l}$	-1.3916	-1.3343	-1.1117	-1.0717	-1.0717	-1.0717	-1.0717	-1.0717	-1.0717

Medium Radius L.E.
 Run No. = 25 , Point No. = 522
 $C_N = 1.082$, $C_m = -0.1680$
 $\alpha = 22.7^\circ$, $M_\infty = 0.832$
 $R_{mac} = 59.7 \times 10^6$

Leading Edge Pressures



x/c_R	starb'd C_p	port C_p
0.10	-1.3612	*****
0.20	-1.5480	-1.3916
0.30	-1.3454	*****
0.40	-1.3554	-1.3343
0.50	-1.3339	*****
0.60	-0.7814	-1.1117
0.70	-0.7128	*****
0.80	-0.8487	-1.0717
0.90	*****	*****
0.95	-0.4304	-0.4734

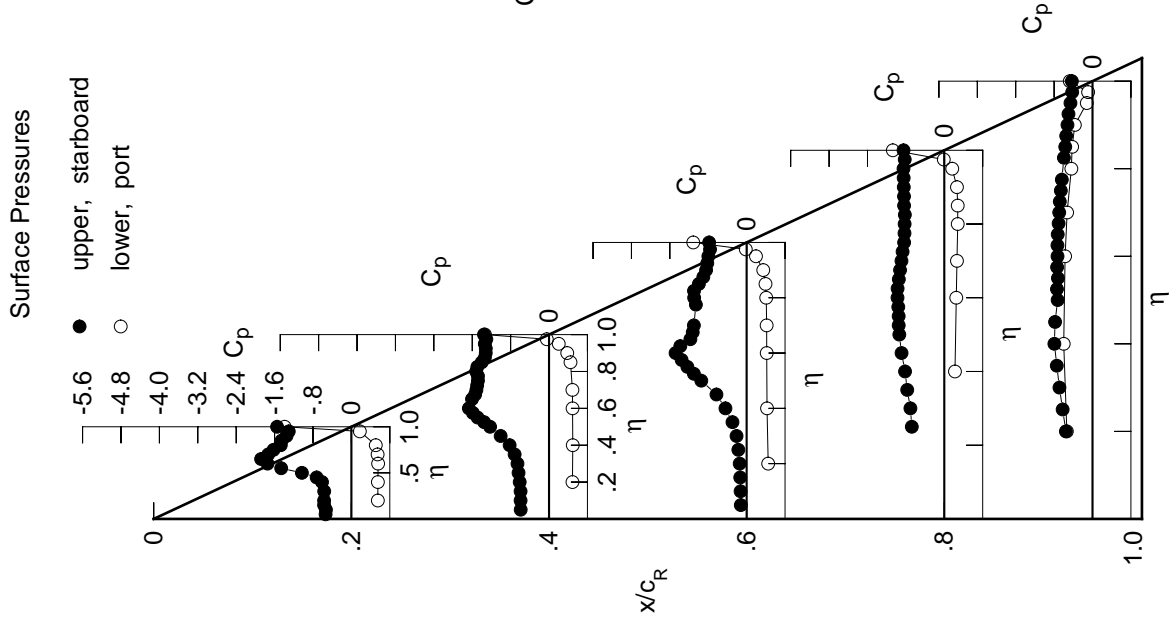

Table G2. Continued.

η	$x/c_R = .2$		$x/c_R = .4$		$x/c_R = .6$		$x/c_R = .8$		$x/c_R = .95$	
	$C_{p,u}$	$C_{p,u}$	$C_{p,u}$	$C_{p,u}$	$C_{p,u}$	$C_{p,u}$	$C_{p,u}$	$C_{p,u}$	$C_{p,u}$	$C_{p,u}$
0.050	-0.6341	-0.6732	-0.0423	*****	*****	*****	*****	*****	*****	*****
0.100	-0.6271	-0.6765	-0.0573	*****	*****	*****	*****	*****	*****	*****
0.150	-0.6329	-0.6805	-0.0735	*****	*****	*****	*****	*****	*****	*****
0.200	-0.6524	-0.6903	-0.0975	*****	*****	*****	*****	*****	*****	*****
0.250	*****	-0.7240	-0.1425	-0.8317	-0.8317	-0.8317	-0.8317	-0.8317	-0.8317	-0.8317
0.300	-0.6905	-0.7764	-0.2102	-0.8741	-0.8741	-0.8741	-0.8741	-0.8741	-0.8741	-0.8741
0.350	*****	-0.8662	-0.3238	-0.9424	-0.9424	-0.9424	-0.9424	-0.9424	-0.9424	-0.9424
0.400	-0.8389	-1.0051	-0.5065	-0.9904	-0.9904	-0.9904	-0.9904	-0.9904	-0.9904	-0.9904
0.450	-1.0560	-1.1997	-0.7338	-1.0358	-1.0358	-1.0358	-1.0358	-1.0358	-1.0358	-1.0358
0.500	-1.3848	-1.3923	-1.0390	-1.0293	-1.0293	-1.0293	-1.0293	-1.0293	-1.0293	-1.0293
0.525	*****	-1.4912	-1.1763	-1.0215	-1.0215	-1.0215	-1.0215	-1.0215	-1.0215	-1.0215
0.550	-1.6666	-1.6061	-1.2999	-1.0015	-1.0015	-1.0015	-1.0015	-1.0015	-1.0015	-1.0015
0.575	*****	-1.6822	-1.4034	-1.0049	-1.0049	-1.0049	-1.0049	-1.0049	-1.0049	-1.0049
0.600	-1.8378	-1.7472	-1.5000	-1.0123	-1.0123	-1.0123	-1.0123	-1.0123	-1.0123	-1.0123
0.625	*****	*****	-1.4203	-1.0095	-1.0095	-1.0095	-1.0095	-1.0095	-1.0095	-1.0095
0.650	-1.7445	-1.6019	-1.2305	-0.9943	-0.9943	-0.9943	-0.9943	-0.9943	-0.9943	-0.9943
0.675	*****	-1.5441	-1.1703	-0.9754	-0.9754	-0.9754	-0.9754	-0.9754	-0.9754	-0.9754
0.700	-1.7512	-1.5195	-1.1404	-0.9517	-0.9517	-0.9517	-0.9517	-0.9517	-0.9517	-0.9517
0.725	*****	-1.5069	*****	-0.9367	-0.9367	-0.9367	-0.9367	-0.9367	-0.9367	-0.9367
0.750	-1.7484	-1.4996	*****	-0.9114	-0.9114	-0.9114	-0.9114	-0.9114	-0.9114	-0.9114
0.775	*****	-1.5217	-1.0179	-0.9085	-0.9085	-0.9085	-0.9085	-0.9085	-0.9085	-0.9085
0.800	-1.4857	-1.5559	-1.0045	-0.9103	-0.9103	-0.9103	-0.9103	-0.9103	-0.9103	-0.9103
0.825	*****	-1.5192	-1.0139	-0.9038	-0.9038	-0.9038	-0.9038	-0.9038	-0.9038	-0.9038
0.850	-1.4768	-1.4565	-0.9648	-0.9214	-0.9214	-0.9214	-0.9214	-0.9214	-0.9214	-0.9214
0.875	*****	-1.4197	-0.8967	-0.9191	-0.9191	-0.9191	-0.9191	-0.9191	-0.9191	-0.9191
0.900	-1.3958	-1.4106	-0.8209	-0.9155	-0.9155	-0.9155	-0.9155	-0.9155	-0.9155	-0.9155
0.925	*****	-1.4185	-0.7661	-0.9018	-0.9018	-0.9018	-0.9018	-0.9018	-0.9018	-0.9018
0.950	-1.3730	-1.4251	-0.7342	-0.8939	-0.8939	-0.8939	-0.8939	-0.8939	-0.8939	-0.8939
0.975	*****	-1.4006	-0.7142	-0.8768	-0.8768	-0.8768	-0.8768	-0.8768	-0.8768	-0.8768
1.000	-1.5843	-1.4412	-0.7232	-0.8739	-0.8739	-0.8739	-0.8739	-0.8739	-0.8739	-0.8739
-0.200	$C_{p,l}$	$C_{p,l}$	$C_{p,l}$	$C_{p,l}$	$C_{p,l}$	$C_{p,l}$	$C_{p,l}$	$C_{p,l}$	$C_{p,l}$	$C_{p,l}$
-0.400	0.6030	0.5306	0.4820	*****	*****	*****	*****	*****	*****	*****
-0.600	0.6028	0.5367	0.4600	0.2480	0.2480	0.2480	0.2480	0.2480	0.2480	0.2480
-0.700	0.6031	0.5299	0.4532	0.2733	0.2733	0.2733	0.2733	0.2733	0.2733	0.2733
-0.800	0.5856	0.5254	0.4513	0.2860	0.2860	0.2860	0.2860	0.2860	0.2860	0.2860
-0.850	0.5332	*****	0.4419	0.2983	0.2983	0.2983	0.2983	0.2983	0.2983	0.2983
-0.900	*****	0.4683	0.4238	0.2978	0.2978	0.2978	0.2978	0.2978	0.2978	0.2978
-0.950	0.1547	0.1864	0.2089	0.1705	0.1705	0.1705	0.1705	0.1705	0.1705	0.1705
-0.975	*****	-0.0845	-0.0068	-0.0102	-0.0102	-0.0102	-0.0102	-0.0102	-0.0102	-0.0102
-1.000	-1.4425	-1.4273	-0.7011	-0.8320	-0.8320	-0.8320	-0.8320	-0.8320	-0.8320	-0.8320

Medium Radius L.E.
 Run No. = 25 , Point No. = 523
 $C_N = 1.124$, $C_m = -0.1672$
 $\alpha = 24.7^\circ$, $M_\infty = 0.830$
 $R_{mac} = 59.7 \times 10^6$

Leading Edge Pressures

● starboard
 ○ port

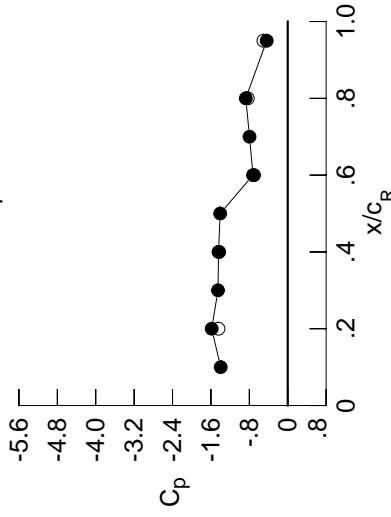

x/c_R	starb'd C_p	port C_p
0.10	-1.3968	*****
0.20	-1.5843	-1.4425
0.30	-1.4526	*****
0.40	-1.4412	-1.4273
0.50	-1.4076	*****
0.60	-0.7232	-0.7011
0.70	-0.7960	*****
0.80	-0.8739	-0.8320
0.90	*****	*****
0.95	-0.4386	-0.5062

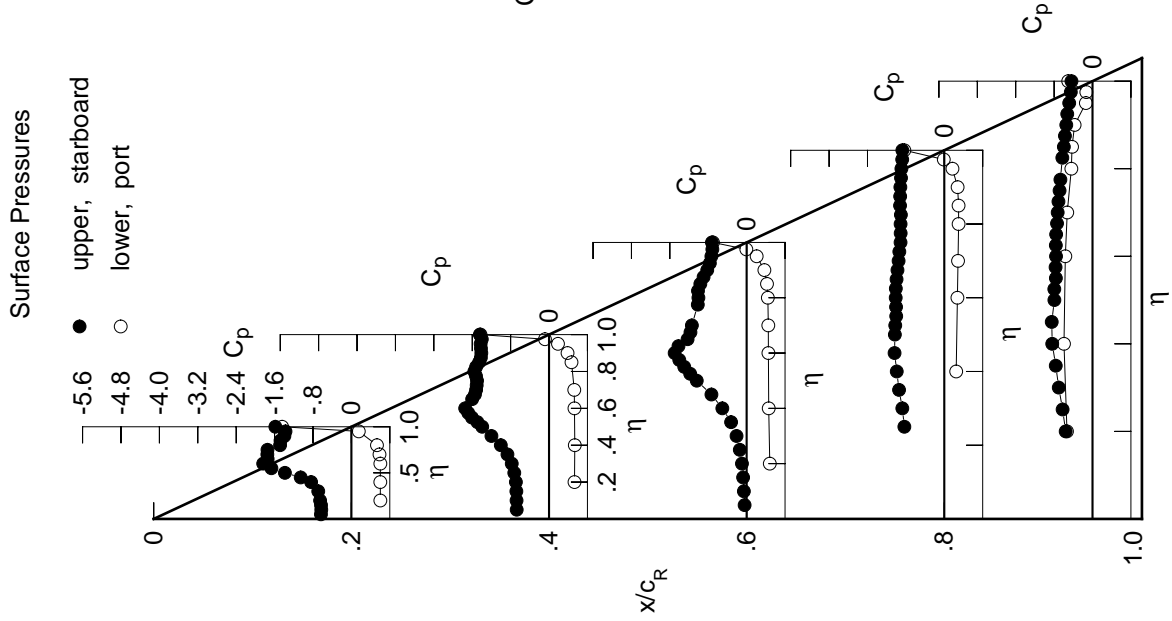
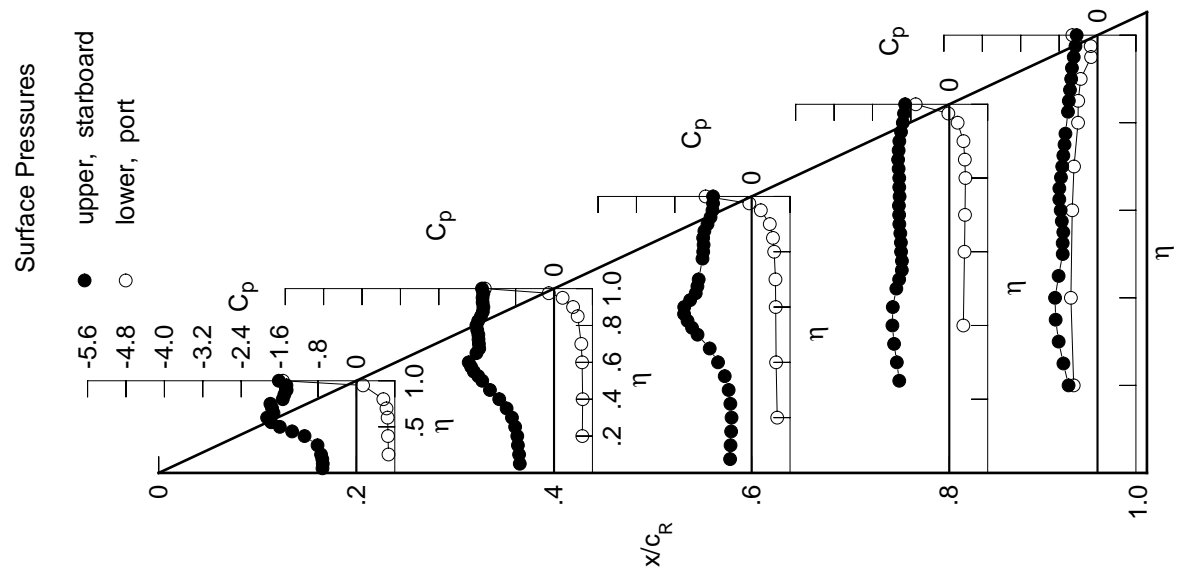
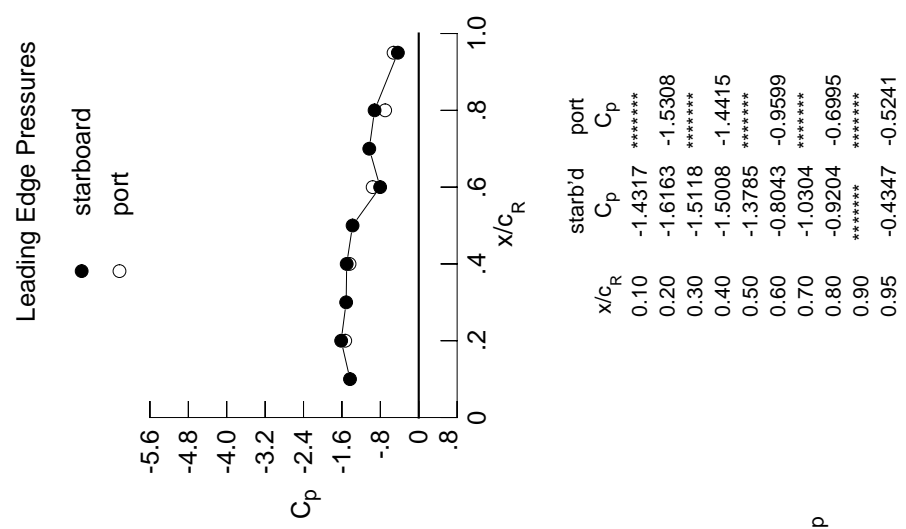

Table G2. Concluded.

η	$x/c_R = .2$		$x/c_R = .4$		$x/c_R = .6$		$x/c_R = .8$		$x/c_R = .95$	
	$C_{p,u}$	$C_{p,l}$	$C_{p,u}$	$C_{p,l}$	$C_{p,u}$	$C_{p,l}$	$C_{p,u}$	$C_{p,l}$	$C_{p,u}$	$C_{p,l}$
0.050	-0.7064	-0.7137	-0.4489	*****	*****	*****	*****	*****	*****	*****
0.100	-0.7007	-0.7281	-0.4390	*****	*****	*****	*****	*****	*****	*****
0.150	-0.7106	-0.7528	-0.4270	*****	*****	*****	*****	*****	*****	*****
0.200	-0.7360	-0.7653	-0.4184	*****	*****	*****	*****	*****	*****	*****
0.250	*****	-0.8107	-0.4434	-1.0421	-0.7105	*****	*****	*****	*****	*****
0.300	-0.8092	-0.8772	-0.4790	-1.0929	-0.8099	*****	*****	*****	*****	*****
0.350	*****	-0.9879	-0.5611	-1.1505	-0.8718	*****	*****	*****	*****	*****
0.400	-1.0803	-1.1418	-0.7001	-1.1845	-0.8850	*****	*****	*****	*****	*****
0.450	-1.3395	-1.3355	-0.8737	-1.1770	-0.8105	*****	*****	*****	*****	*****
0.500	-1.5951	-1.4961	-1.1274	-1.1029	-0.7249	*****	*****	*****	*****	*****
0.525	*****	-1.5781	-1.2418	-1.0449	-0.7255	*****	*****	*****	*****	*****
0.550	-1.7754	-1.6710	-1.3349	-0.9889	-0.7128	*****	*****	*****	*****	*****
0.575	*****	-1.7265	-1.4076	-0.9863	-0.7441	*****	*****	*****	*****	*****
0.600	-1.8597	-1.7773	-1.4051	-1.0047	-0.7668	*****	*****	*****	*****	*****
0.625	*****	*****	-1.2816	-1.0080	-0.7957	*****	*****	*****	*****	*****
0.650	-1.7268	-1.6164	-1.1649	-1.0203	-0.7955	*****	*****	*****	*****	*****
0.675	*****	-1.5586	-1.1292	-1.0405	-0.7617	*****	*****	*****	*****	*****
0.700	-1.7561	-1.5657	-1.1032	-1.0449	-0.7353	*****	*****	*****	*****	*****
0.725	*****	-1.5733	*****	-1.0499	-0.7118	*****	*****	*****	*****	*****
0.750	-1.7923	-1.5771	*****	-1.0351	-0.6873	*****	*****	*****	*****	*****
0.775	*****	-1.6001	-1.0240	-1.0420	-0.6677	*****	*****	*****	*****	*****
0.800	-1.5343	-1.6179	-1.0090	-1.0428	*****	*****	*****	*****	*****	*****
0.825	*****	-1.5801	-1.0006	-1.0556	-0.6155	*****	*****	*****	*****	*****
0.850	-1.5006	-1.5221	-1.0102	-1.0662	-0.5973	*****	*****	*****	*****	*****
0.875	*****	-1.4834	-0.9851	-1.0556	-0.5738	*****	*****	*****	*****	*****
0.900	-1.4537	-1.4719	-0.9196	-1.0405	-0.5490	*****	*****	*****	*****	*****
0.925	*****	-1.4875	-0.8561	-1.0055	-0.5325	*****	*****	*****	*****	*****
0.950	-1.4574	-1.4885	-0.8164	-0.9683	-0.4950	*****	*****	*****	*****	*****
0.975	*****	-1.4728	-0.8043	-0.9436	-0.4592	*****	*****	*****	*****	*****
1.000	-1.6163	-1.5008	-0.8043	-0.9204	-0.4347	*****	*****	*****	*****	*****
-0.200	0.6686	0.5894	0.5328	*****	-0.4961	*****	*****	*****	*****	*****
-0.400	0.6586	0.5961	0.5098	0.2928	-0.5543	*****	*****	*****	*****	*****
-0.600	0.6512	0.5851	0.5011	0.3167	-0.5267	*****	*****	*****	*****	*****
-0.700	0.6271	0.5678	0.4962	0.3276	-0.4895	*****	*****	*****	*****	*****
-0.800	0.5613	*****	0.4695	0.3360	-0.4055	*****	*****	*****	*****	*****
-0.850	*****	0.4927	0.4440	0.3239	-0.4023	*****	*****	*****	*****	*****
-0.900	*****	0.3969	0.3779	0.2954	-0.3506	*****	*****	*****	*****	*****
-0.950	0.1389	0.1784	0.1912	0.1735	-0.1339	*****	*****	*****	*****	*****
-0.975	*****	-0.1099	-0.0481	-0.0202	-0.1424	*****	*****	*****	*****	*****
-1.000	-1.5308	-1.4415	-0.9599	-0.6995	-0.5241	*****	*****	*****	*****	*****

Medium Radius L.E.
 Run No. = 25 , Point No. = 524
 $C_N = 1.210$, $C_m = -0.1804$
 $\alpha = 26.8^\circ$, $M_\infty = 0.830$
 $R_{mac} = 59.5 \times 10^6$



x/c_R	starb'd C_p	port C_p
0.10	-1.4317	*****
0.20	-1.6163	-1.5308
0.30	-1.5118	*****
0.40	-1.5008	-1.4415
0.50	-1.3785	*****
0.60	-0.8043	-0.9599
0.70	-1.0304	*****
0.80	-0.9204	-0.6995
0.90	*****	*****
0.95	-0.4347	-0.5241

Table G3. Tabulations and Plots of Surface Pressure Coefficients.

η	$x/c_R = .2$		$x/c_R = .4$		$x/c_R = .6$		$x/c_R = .8$		$x/c_R = .95$	
	$C_{p,u}$	$C_{p,l}$	$C_{p,u}$	$C_{p,l}$	$C_{p,u}$	$C_{p,l}$	$C_{p,u}$	$C_{p,l}$	$C_{p,u}$	$C_{p,l}$
0.050	0.0019	0.0153	0.1422	0.1422	0.1422	0.1422	0.1422	0.1422	0.1422	0.1422
0.100	0.0051	0.0154	0.1340	0.1340	0.1340	0.1340	0.1340	0.1340	0.1340	0.1340
0.150	0.0014	0.0165	0.1221	0.1221	0.1221	0.1221	0.1221	0.1221	0.1221	0.1221
0.200	-0.0002	0.0220	0.1108	0.1108	0.1108	0.1108	0.1108	0.1108	0.1108	0.1108
0.250	0.0000	0.0152	0.0978	0.0978	0.1209	0.1209	0.1209	0.1209	0.1209	0.1209
0.300	-0.0072	0.0155	0.0880	0.0880	0.1069	0.1069	0.1069	0.1069	0.1069	0.1069
0.350	0.0000	0.0138	0.0779	0.0779	0.0944	0.0944	0.0944	0.0944	0.0944	0.0944
0.400	-0.0215	0.0133	0.0712	0.0712	0.0823	0.0823	0.0823	0.0823	0.0823	0.0823
0.450	-0.0273	0.0087	0.0772	0.0772	0.0754	0.0754	0.0754	0.0754	0.0754	0.0754
0.500	-0.0336	0.0096	0.0524	0.0680	0.06415	0.06415	0.06415	0.06415	0.06415	0.06415
0.525	0.0000	0.0052	0.0510	0.0677	0.06539	0.06539	0.06539	0.06539	0.06539	0.06539
0.550	-0.0331	-0.0011	0.0479	0.0623	0.06528	0.06528	0.06528	0.06528	0.06528	0.06528
0.575	0.0000	-0.0018	0.0519	0.0628	0.06676	0.06676	0.06676	0.06676	0.06676	0.06676
0.600	-0.0391	-0.0052	0.0389	0.0632	0.06728	0.06728	0.06728	0.06728	0.06728	0.06728
0.625	0.0000	0.0000	0.0394	0.0583	0.06844	0.06844	0.06844	0.06844	0.06844	0.06844
0.650	-0.0379	-0.0067	0.0349	0.0568	0.07011	0.07011	0.07011	0.07011	0.07011	0.07011
0.675	0.0000	-0.0167	0.0261	0.0595	0.07035	0.07035	0.07035	0.07035	0.07035	0.07035
0.700	-0.0328	-0.0248	0.0262	0.0576	0.07123	0.07123	0.07123	0.07123	0.07123	0.07123
0.725	0.0000	-0.0320	0.0000	0.0560	0.07124	0.07124	0.07124	0.07124	0.07124	0.07124
0.750	-0.0245	-0.0381	0.0034	0.0554	0.07065	0.07065	0.07065	0.07065	0.07065	0.07065
0.775	0.0000	-0.0408	0.0034	0.0616	0.06966	0.06966	0.06966	0.06966	0.06966	0.06966
0.800	-0.0044	-0.0438	-0.0080	0.0658	0.0658	0.0658	0.0658	0.0658	0.0658	0.0658
0.825	0.0000	-0.0415	-0.0204	0.0627	0.06725	0.06725	0.06725	0.06725	0.06725	0.06725
0.850	0.0182	-0.0367	-0.0276	0.0819	0.06587	0.06587	0.06587	0.06587	0.06587	0.06587
0.875	0.0000	-0.0259	-0.0337	0.0915	0.07187	0.07187	0.07187	0.07187	0.07187	0.07187
0.900	0.0534	-0.0140	-0.0294	0.0977	0.07430	0.07430	0.07430	0.07430	0.07430	0.07430
0.925	0.0000	0.0110	-0.0154	0.0911	0.0906	0.0906	0.0906	0.0906	0.0906	0.0906
0.950	0.1030	0.0470	0.0157	0.0623	0.03654	0.03654	0.03654	0.03654	0.03654	0.03654
0.975	0.0000	0.1017	0.0735	0.0005	-0.1993	-0.1993	-0.1993	-0.1993	-0.1993	-0.1993
1.000	0.2208	0.2142	0.2075	0.1547	0.0699	0.0699	0.0699	0.0699	0.0699	0.0699
-0.200	-0.0260	-0.0012	0.0858	0.0000	-0.6363	-0.6363	-0.6363	-0.6363	-0.6363	-0.6363
-0.400	-0.0505	-0.0035	0.0441	-0.1015	-0.6244	-0.6244	-0.6244	-0.6244	-0.6244	-0.6244
-0.600	-0.0742	-0.0261	0.0164	-0.0822	-0.6739	-0.6739	-0.6739	-0.6739	-0.6739	-0.6739
-0.700	-0.0757	-0.0631	-0.0099	-0.0822	-0.7064	-0.7064	-0.7064	-0.7064	-0.7064	-0.7064
-0.800	-0.0609	0.0000	-0.0540	-0.0954	-0.7081	-0.7081	-0.7081	-0.7081	-0.7081	-0.7081
-0.850	0.0000	-0.0947	-0.0865	-0.1245	-0.7456	-0.7456	-0.7456	-0.7456	-0.7456	-0.7456
-0.900	0.0000	-0.0821	-0.1010	-0.1611	-0.5063	-0.5063	-0.5063	-0.5063	-0.5063	-0.5063
-0.950	0.0399	-0.0342	-0.0710	-0.1509	-0.3789	-0.3789	-0.3789	-0.3789	-0.3789	-0.3789
-0.975	0.0000	0.0189	-0.0231	-0.0993	-0.2660	-0.2660	-0.2660	-0.2660	-0.2660	-0.2660
-1.000	0.1954	0.1916	0.1513	0.1372	0.0537	0.0537	0.0537	0.0537	0.0537	0.0537

Medium Radius L.E.
 Run No. = 27, Point No. = 530
 $C_N = -0.019$, $C_m = -0.0026$
 $\alpha = -0.8^\circ$, $M_\infty = 0.870$
 $R_{mac} = 59.9 \times 10^6$

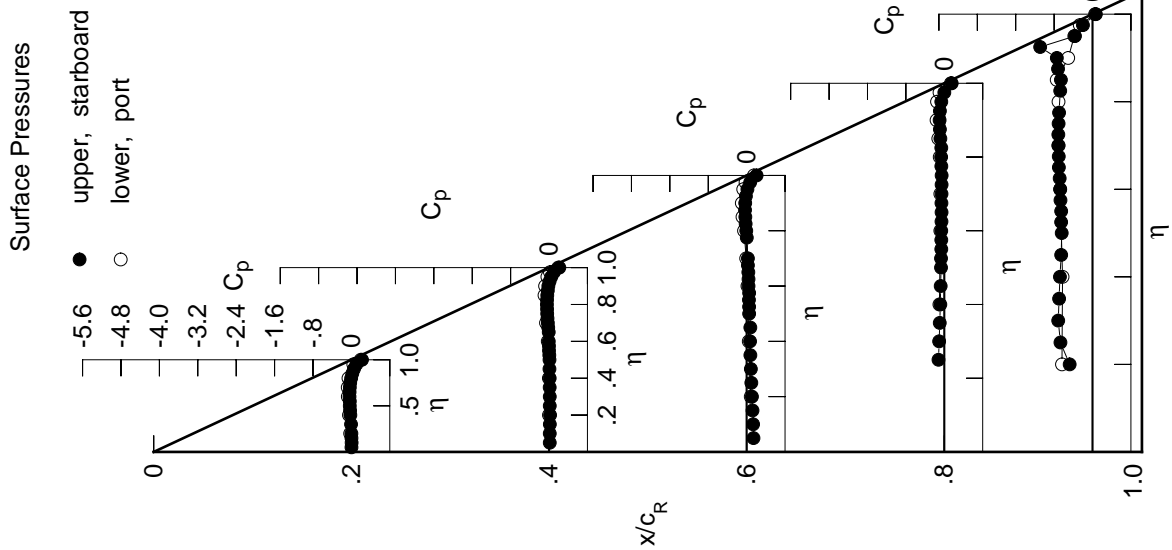

Leading Edge Pressures

● starboard
 ○ port

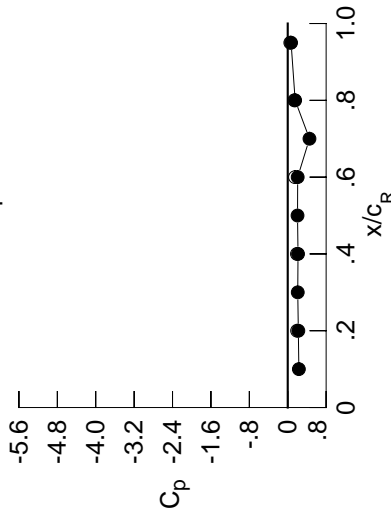

x/c_R	starb'd C_p	port C_p
0.10	0.2319	0.1954
0.20	0.2208	0.1954
0.30	0.2087	0.1916
0.40	0.2142	0.1916
0.50	0.2042	0.1513
0.60	0.2075	0.1513
0.70	0.4531	0.1372
0.80	0.1547	0.1372
0.90	0.0699	0.0537
0.95	0.0699	0.0537

Table G3. Continued.

η	x/c_R .2	x/c_R .4	x/c_R .6	x/c_R .8	x/c_R .95
	$C_{p,u}$	$C_{p,u}$	$C_{p,u}$	$C_{p,u}$	$C_{p,u}$
0.050	-0.0048	0.0095	0.1385	*****	*****
0.100	-0.0011	0.0087	0.1298	*****	*****
0.150	-0.0051	0.0106	0.1175	*****	*****
0.200	-0.0071	0.0153	0.1068	*****	-0.4667
0.250	*****	0.0090	0.0936	-0.1259	-0.6623
0.300	-0.0133	0.0092	0.0834	-0.1120	-0.7198
0.350	*****	0.0074	0.0733	-0.0993	-0.7057
0.400	-0.0298	0.0059	0.0657	-0.0871	-0.6905
0.450	-0.0350	0.0020	0.0723	-0.0804	-0.6700
0.500	-0.0418	0.0030	0.0477	-0.0742	-0.6686
0.525	*****	-0.0024	0.0450	-0.0730	-0.6786
0.550	-0.0424	-0.0082	0.0415	-0.0682	-0.6785
0.575	*****	-0.0096	0.0459	-0.0679	-0.6922
0.600	-0.0491	-0.0126	0.0325	-0.0699	-0.6967
0.625	*****	*****	0.0337	-0.0641	-0.7037
0.650	-0.0484	-0.0151	0.0282	-0.0628	-0.7151
0.675	*****	-0.0262	0.0188	-0.0659	-0.7138
0.700	-0.0438	-0.0344	0.0183	-0.0642	-0.7207
0.725	*****	-0.0424	*****	-0.0637	-0.7188
0.750	-0.0367	-0.0494	*****	-0.0624	-0.7132
0.775	*****	-0.0529	-0.0059	-0.0697	-0.7030
0.800	-0.0173	-0.0564	-0.0191	-0.0751	*****
0.825	*****	-0.0558	-0.0313	-0.0712	-0.6738
0.850	0.0046	-0.0516	-0.0409	-0.0931	-0.6576
0.875	*****	-0.0423	-0.0484	-0.1038	-0.7266
0.900	0.0389	-0.0304	-0.0469	-0.1139	-0.7389
0.925	*****	-0.0072	-0.0345	-0.1095	-1.0971
0.950	0.0885	0.0285	-0.0048	-0.0826	-0.3778
0.975	*****	0.0818	0.0523	-0.0222	-0.2161
1.000	0.2250	0.2210	0.2241	0.1663	0.0786
	$C_{p,l}$	$C_{p,l}$	$C_{p,l}$	$C_{p,l}$	$C_{p,l}$
-0.200	-0.0189	0.0047	0.0912	*****	-0.6469
-0.400	-0.0425	0.0041	0.0486	-0.0968	-0.6587
-0.600	-0.0638	-0.0185	0.0223	-0.0765	-0.7055
-0.700	-0.0640	-0.0530	-0.0020	-0.0761	-0.7224
-0.800	-0.0472	*****	-0.0429	-0.0860	-0.7044
-0.850	*****	-0.0788	-0.0721	-0.1131	-0.7402
-0.900	*****	-0.0633	-0.0831	-0.1447	-0.5407
-0.950	0.0573	-0.0126	-0.0479	-0.1272	-0.3658
-0.975	*****	0.0429	0.0034	-0.0722	-0.2456
-1.000	0.2022	0.2022	0.1659	0.1567	0.0669

Surface Pressures

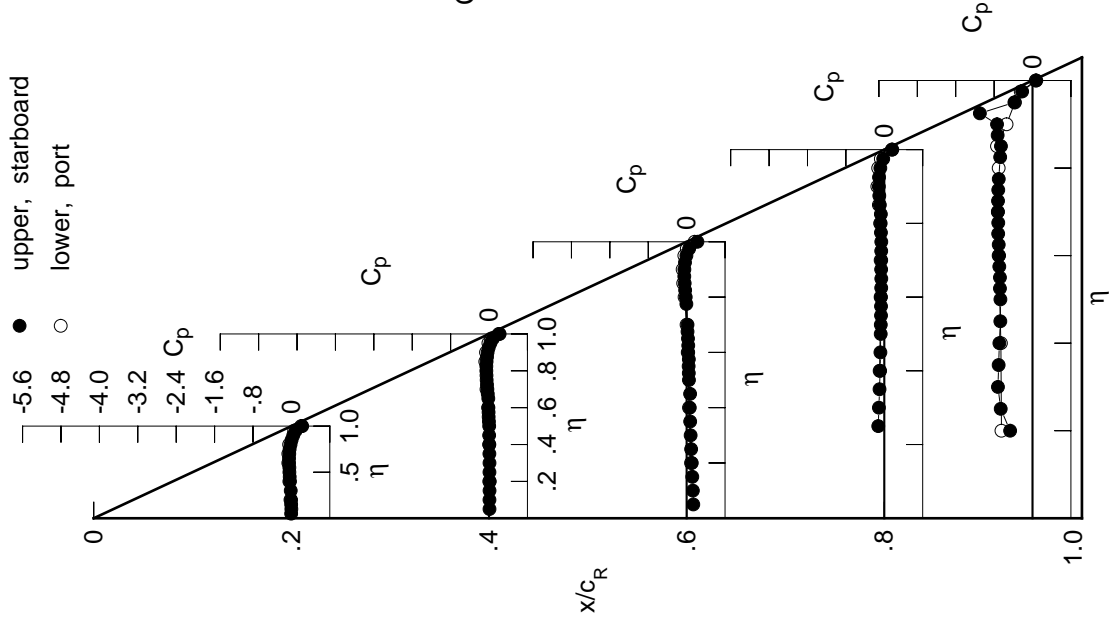

Medium Radius L.E.
 Run No. = 27, Point No. = 531
 $C_N = -0.006$, $C_m = -0.0045$
 $\alpha = -0.4^\circ$, $M_\infty = 0.869$
 $R_{mac} = 59.8 \times 10^6$

Leading Edge Pressures

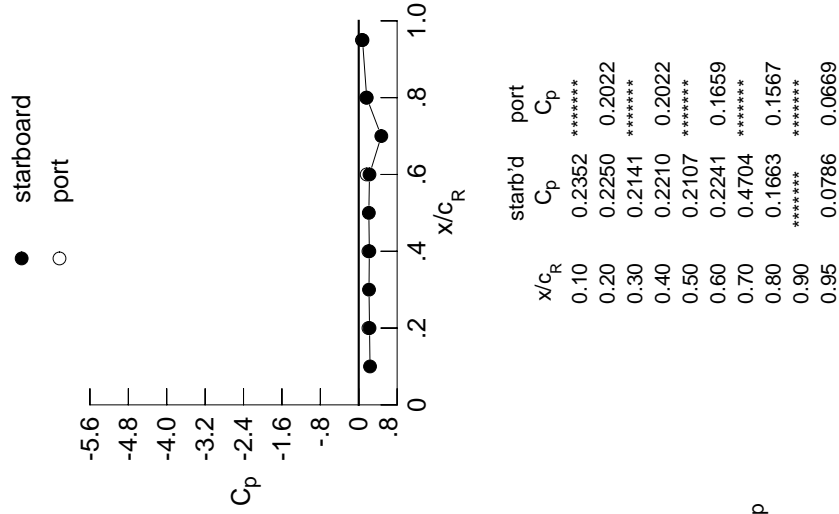

x/c_R	starb'd C_p	port C_p
0.10	0.2352	*****
0.20	0.2250	0.2022
0.30	0.2141	*****
0.40	0.2210	0.2022
0.50	0.2107	*****
0.60	0.2241	0.1659
0.70	0.4704	*****
0.80	0.1663	0.1567
0.90	*****	*****
0.95	0.0786	0.0669

Table G3. Continued.

η	$x/c_R = .2$		$x/c_R = .4$		$x/c_R = .6$		$x/c_R = .8$		$x/c_R = .95$	
	$C_{p,u}$	$C_{p,u}$	$C_{p,u}$	$C_{p,u}$	$C_{p,u}$	$C_{p,u}$	$C_{p,u}$	$C_{p,u}$	$C_{p,u}$	$C_{p,u}$
0.050	-0.0255	-0.0088	0.1265	0.1265	0.1265	0.1265	0.1265	0.1265	0.1265	0.1265
0.100	-0.0225	-0.0091	0.1179	0.1179	0.1179	0.1179	0.1179	0.1179	0.1179	0.1179
0.150	-0.0262	-0.0078	0.1050	0.1050	0.1050	0.1050	0.1050	0.1050	0.1050	0.1050
0.200	-0.0275	-0.0027	0.0938	0.0938	0.0938	0.0938	0.0938	0.0938	0.0938	0.0938
0.250	*****	-0.0099	0.0804	0.0804	0.0804	0.0804	0.0804	0.0804	0.0804	0.0804
0.300	-0.0351	-0.0098	0.0691	0.0691	0.0691	0.0691	0.0691	0.0691	0.0691	0.0691
0.350	*****	-0.0130	0.0593	0.0593	0.0593	0.0593	0.0593	0.0593	0.0593	0.0593
0.400	-0.0528	-0.0138	0.0510	0.0510	0.0510	0.0510	0.0510	0.0510	0.0510	0.0510
0.450	-0.0594	-0.0192	0.0571	0.0571	0.0571	0.0571	0.0571	0.0571	0.0571	0.0571
0.500	-0.0689	-0.0190	0.0308	0.0308	0.0308	0.0308	0.0308	0.0308	0.0308	0.0308
0.525	*****	-0.0250	0.0289	0.0289	0.0289	0.0289	0.0289	0.0289	0.0289	0.0289
0.550	-0.0706	-0.0323	0.0242	0.0242	0.0242	0.0242	0.0242	0.0242	0.0242	0.0242
0.575	*****	-0.0342	0.0283	0.0283	0.0283	0.0283	0.0283	0.0283	0.0283	0.0283
0.600	-0.0794	-0.0381	0.0141	0.0141	0.0141	0.0141	0.0141	0.0141	0.0141	0.0141
0.625	*****	*****	0.0136	0.0136	0.0136	0.0136	0.0136	0.0136	0.0136	0.0136
0.650	-0.0814	-0.0428	0.0081	0.0081	0.0081	0.0081	0.0081	0.0081	0.0081	0.0081
0.675	*****	-0.0549	-0.0029	-0.0029	-0.0029	-0.0029	-0.0029	-0.0029	-0.0029	-0.0029
0.700	-0.0799	-0.0650	-0.0046	-0.0046	-0.0046	-0.0046	-0.0046	-0.0046	-0.0046	-0.0046
0.725	*****	-0.0756	*****	*****	*****	*****	*****	*****	*****	*****
0.750	-0.0744	-0.0850	*****	*****	*****	*****	*****	*****	*****	*****
0.775	*****	-0.0919	-0.0360	-0.0360	-0.0360	-0.0360	-0.0360	-0.0360	-0.0360	-0.0360
0.800	-0.0576	-0.0978	-0.0515	-0.0515	-0.0515	-0.0515	-0.0515	-0.0515	-0.0515	-0.0515
0.825	*****	-0.1010	-0.0686	-0.0686	-0.0686	-0.0686	-0.0686	-0.0686	-0.0686	-0.0686
0.850	-0.0383	-0.0998	-0.0837	-0.0837	-0.0837	-0.0837	-0.0837	-0.0837	-0.0837	-0.0837
0.875	*****	-0.0938	-0.0965	-0.0965	-0.0965	-0.0965	-0.0965	-0.0965	-0.0965	-0.0965
0.900	-0.0069	-0.0865	-0.1010	-0.1010	-0.1010	-0.1010	-0.1010	-0.1010	-0.1010	-0.1010
0.925	*****	-0.0677	-0.0945	-0.0945	-0.0945	-0.0945	-0.0945	-0.0945	-0.0945	-0.0945
0.950	0.0395	-0.0347	-0.0734	-0.0734	-0.0734	-0.0734	-0.0734	-0.0734	-0.0734	-0.0734
0.975	*****	0.0142	-0.0218	-0.0218	-0.0218	-0.0218	-0.0218	-0.0218	-0.0218	-0.0218
1.000	0.2178	0.2098	0.2142	0.2142	0.2142	0.2142	0.2142	0.2142	0.2142	0.2142
	$C_{p,l}$	$C_{p,l}$	$C_{p,l}$	$C_{p,l}$	$C_{p,l}$	$C_{p,l}$	$C_{p,l}$	$C_{p,l}$	$C_{p,l}$	$C_{p,l}$
-0.200	0.0006	0.0227	0.1033	0.1033	0.1033	0.1033	0.1033	0.1033	0.1033	0.1033
-0.400	-0.0202	0.0229	0.0644	0.0644	0.0644	0.0644	0.0644	0.0644	0.0644	0.0644
-0.600	-0.0348	0.0044	0.0401	0.0401	0.0401	0.0401	0.0401	0.0401	0.0401	0.0401
-0.700	-0.0301	-0.0233	0.0203	0.0203	0.0203	0.0203	0.0203	0.0203	0.0203	0.0203
-0.800	-0.0078	*****	-0.0116	-0.0116	-0.0116	-0.0116	-0.0116	-0.0116	-0.0116	-0.0116
-0.850	*****	-0.0336	-0.0321	-0.0321	-0.0321	-0.0321	-0.0321	-0.0321	-0.0321	-0.0321
-0.900	*****	-0.0110	-0.0317	-0.0317	-0.0317	-0.0317	-0.0317	-0.0317	-0.0317	-0.0317
-0.950	0.1040	0.0455	0.0156	0.0156	0.0156	0.0156	0.0156	0.0156	0.0156	0.0156
-0.975	*****	0.1043	0.0712	0.0712	0.0712	0.0712	0.0712	0.0712	0.0712	0.0712
-1.000	0.2002	0.1992	0.1606	0.1606	0.1606	0.1606	0.1606	0.1606	0.1606	0.1606

Medium Radius L.E.
 Run No. = 27, Point No. = 532
 $C_N = 0.038$, $C_m = -0.0127$
 $\alpha = 0.7^\circ$, $M_\infty = 0.870$
 $R_{mac} = 59.8 \times 10^6$

Leading Edge Pressures

● starboard
 ○ port

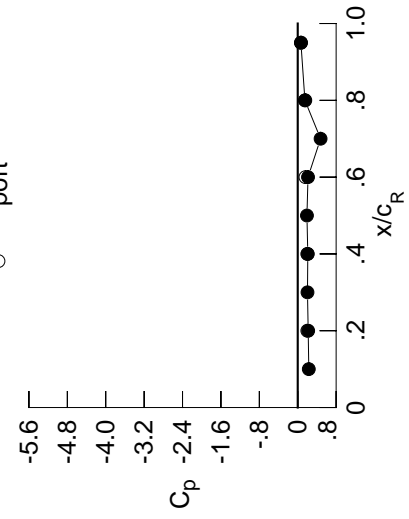

x/c_R	starb'd C_p	port C_p
0.10	0.2307	*****
0.20	0.2178	0.2002
0.30	0.2031	*****
0.40	0.2098	0.1992
0.50	0.1917	*****
0.60	0.2142	0.1606
0.70	0.4757	*****
0.80	0.1498	0.1576
0.90	*****	*****
0.95	0.0664	0.0681

Surface Pressures

● upper, starboard
 ○ lower, port

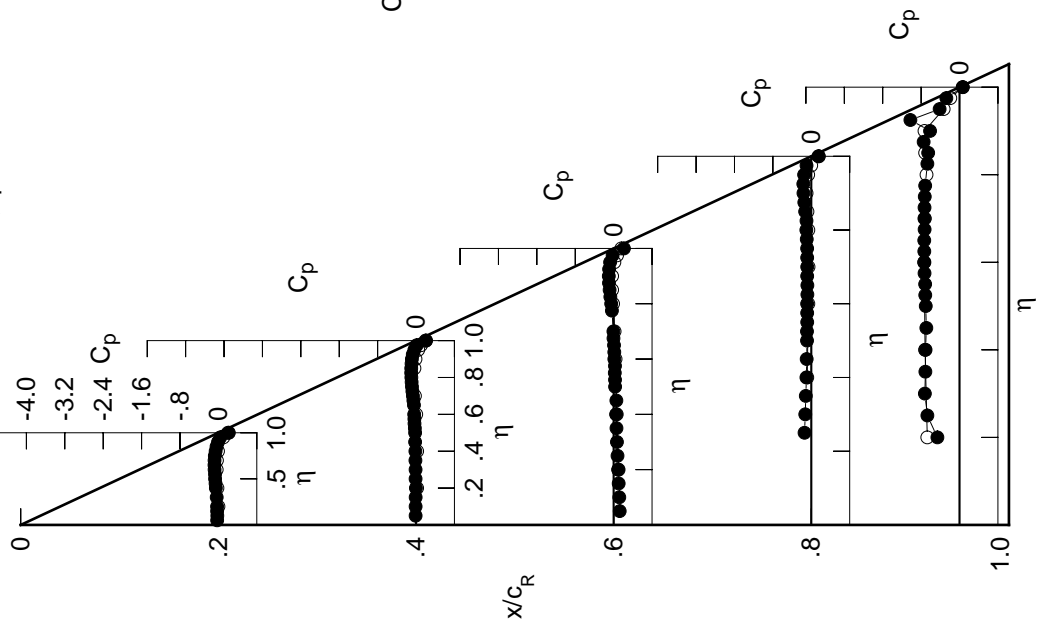

Table G3. Continued.

η	$x/c_R = .2$		$x/c_R = .4$		$x/c_R = .6$		$x/c_R = .8$		$x/c_R = .95$	
	$C_{p,u}$	$C_{p,u}$	$C_{p,u}$	$C_{p,u}$	$C_{p,u}$	$C_{p,u}$	$C_{p,u}$	$C_{p,u}$	$C_{p,u}$	$C_{p,u}$
0.050	-0.0440	-0.0252	0.1141	*****	*****	*****	*****	*****	*****	*****
0.100	-0.0410	-0.0255	0.1044	*****	*****	*****	*****	*****	*****	*****
0.150	-0.0448	-0.0252	0.0926	*****	*****	*****	*****	*****	*****	*****
0.200	-0.0469	-0.0204	0.0810	*****	*****	*****	*****	*****	*****	-0.4076
0.250	*****	-0.0274	0.0670	-0.1516	-0.1516	-0.1516	-0.1516	-0.1516	-0.1516	-0.5920
0.300	-0.0550	-0.0281	0.0559	-0.1377	-0.1377	-0.1377	-0.1377	-0.1377	-0.1377	-0.6878
0.350	*****	-0.0313	0.0453	-0.1260	-0.1260	-0.1260	-0.1260	-0.1260	-0.1260	-0.6826
0.400	-0.0754	-0.0329	0.0362	-0.1143	-0.1143	-0.1143	-0.1143	-0.1143	-0.1143	-0.6573
0.450	-0.0849	-0.0395	0.0415	-0.1084	-0.1084	-0.1084	-0.1084	-0.1084	-0.1084	-0.6248
0.500	-0.0942	-0.0400	0.0142	-0.1032	-0.1032	-0.1032	-0.1032	-0.1032	-0.1032	-0.6158
0.525	*****	-0.0471	0.0122	-0.1032	-0.1032	-0.1032	-0.1032	-0.1032	-0.1032	-0.6322
0.550	-0.0983	-0.0547	0.0061	-0.1001	-0.1001	-0.1001	-0.1001	-0.1001	-0.1001	-0.6322
0.575	*****	-0.0573	0.0096	-0.1012	-0.1012	-0.1012	-0.1012	-0.1012	-0.1012	-0.6475
0.600	-0.1094	-0.0634	0.0055	-0.1024	-0.1024	-0.1024	-0.1024	-0.1024	-0.1024	-0.6569
0.625	*****	*****	-0.0056	-0.0985	-0.0985	-0.0985	-0.0985	-0.0985	-0.0985	-0.6726
0.650	-0.1146	-0.0684	-0.0134	-0.0986	-0.0986	-0.0986	-0.0986	-0.0986	-0.0986	-0.7008
0.675	*****	-0.0829	-0.0239	-0.1034	-0.1034	-0.1034	-0.1034	-0.1034	-0.1034	-0.7142
0.700	-0.1157	-0.0958	-0.0280	-0.1038	-0.1038	-0.1038	-0.1038	-0.1038	-0.1038	-0.7331
0.725	*****	-0.1080	*****	-0.1056	-0.1056	-0.1056	-0.1056	-0.1056	-0.1056	-0.7394
0.750	-0.1135	-0.1199	*****	-0.1086	-0.1086	-0.1086	-0.1086	-0.1086	-0.1086	-0.7377
0.775	*****	-0.1303	-0.0658	-0.1196	-0.1196	-0.1196	-0.1196	-0.1196	-0.1196	-0.7229
0.800	-0.1005	-0.1409	-0.0856	-0.1310	-0.1310	-0.1310	-0.1310	-0.1310	-0.1310	*****
0.825	*****	-0.1473	-0.1081	-0.1300	-0.1300	-0.1300	-0.1300	-0.1300	-0.1300	-0.6658
0.850	-0.0846	-0.1499	-0.1279	-0.1634	-0.1634	-0.1634	-0.1634	-0.1634	-0.1634	-0.6382
0.875	*****	-0.1502	-0.1484	-0.1882	-0.1882	-0.1882	-0.1882	-0.1882	-0.1882	-0.5769
0.900	-0.0573	-0.1469	-0.1601	-0.2155	-0.2155	-0.2155	-0.2155	-0.2155	-0.2155	-0.4666
0.925	*****	-0.1343	-0.1632	-0.2297	-0.2297	-0.2297	-0.2297	-0.2297	-0.2297	-0.6134
0.950	-0.0166	-0.1068	-0.1515	-0.2256	-0.2256	-0.2256	-0.2256	-0.2256	-0.2256	-0.4604
0.975	*****	-0.0701	-0.1131	-0.1910	-0.1910	-0.1910	-0.1910	-0.1910	-0.1910	-0.3442
1.000	0.1845	0.1479	0.1269	0.0563	-0.0002	-0.0002	-0.0002	-0.0002	-0.0002	-0.0002
-0.200	$C_{p,l}$	$C_{p,l}$	$C_{p,l}$	$C_{p,l}$	$C_{p,l}$	$C_{p,l}$	$C_{p,l}$	$C_{p,l}$	$C_{p,l}$	$C_{p,l}$
-0.400	0.0232	0.0416	0.1181	*****	*****	*****	*****	*****	*****	-0.6593
-0.600	0.0053	0.0444	0.0798	-0.0700	-0.0700	-0.0700	-0.0700	-0.0700	-0.0700	-0.6820
-0.700	-0.0038	0.0294	0.0601	-0.0435	-0.0435	-0.0435	-0.0435	-0.0435	-0.0435	-0.7205
-0.800	0.0052	0.0074	0.0432	-0.0376	-0.0376	-0.0376	-0.0376	-0.0376	-0.0376	-0.7128
-0.850	0.0314	*****	0.0203	-0.0353	-0.0353	-0.0353	-0.0353	-0.0353	-0.0353	-0.6716
-0.900	*****	0.0108	0.0078	-0.0464	-0.0464	-0.0464	-0.0464	-0.0464	-0.0464	-0.6954
-0.950	*****	0.0387	0.0163	-0.0532	-0.0532	-0.0532	-0.0532	-0.0532	-0.0532	-0.7474
-0.975	0.1461	0.0974	0.0706	-0.0074	-0.0074	-0.0074	-0.0074	-0.0074	-0.0074	-0.2999
-1.000	0.1694	0.1473	0.0839	0.0817	0.0817	0.0817	0.0817	0.0817	0.0817	0.0163

Medium Radius L.E.
 Run No. = 27, Point No. = 533
 $C_N = 0.077$, $C_m = -0.0166$
 $\alpha = 1.8^\circ$, $M_\infty = 0.868$
 $R_{mac} = 59.8 \times 10^6$

Leading Edge Pressures

● starboard
 ○ port

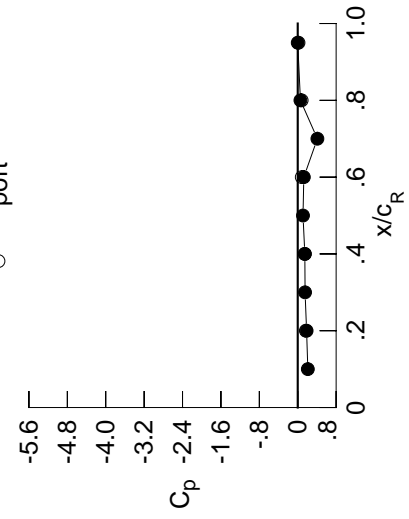

x/c_R	starb'd C_p	port C_p
0.10	0.2106	*****
0.20	0.1845	0.1694
0.30	0.1530	*****
0.40	0.1479	0.1473
0.50	0.1099	*****
0.60	0.1269	0.0839
0.70	0.4093	*****
0.80	0.0563	0.0817
0.90	*****	*****
0.95	-0.0002	0.0163

Surface Pressures

● upper, starboard
 ○ lower, port

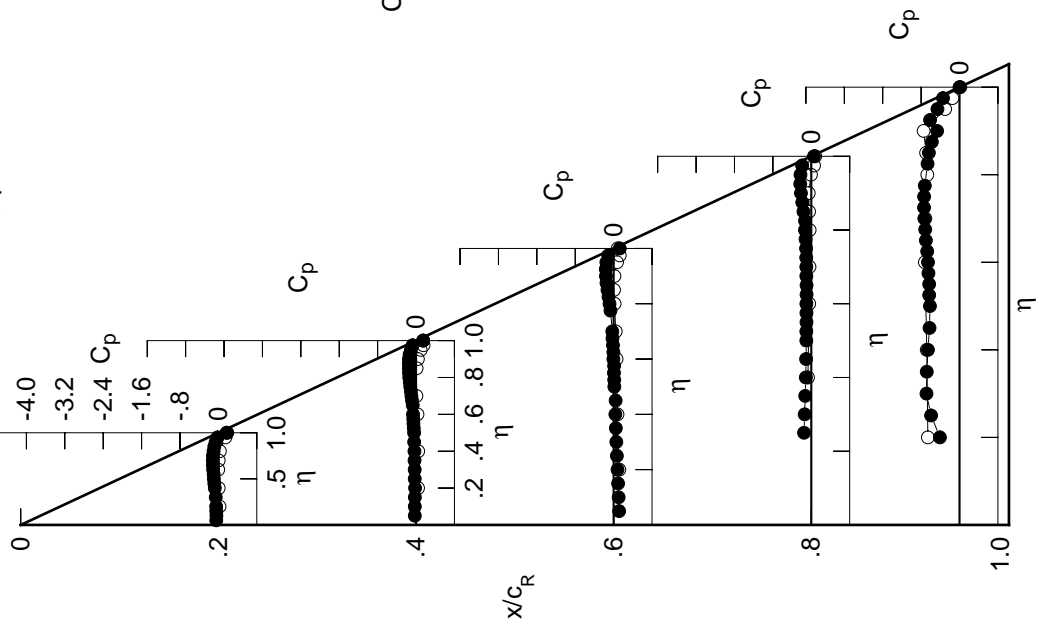

Table G3. Continued.

η	$x/c_R = .2$		$x/c_R = .4$		$x/c_R = .6$		$x/c_R = .8$		$x/c_R = .95$	
	$C_{p,u}$	$C_{p,u}$	$C_{p,u}$	$C_{p,u}$	$C_{p,u}$	$C_{p,u}$	$C_{p,u}$	$C_{p,u}$	$C_{p,u}$	$C_{p,u}$
0.050	-0.0639	-0.0436	0.1019	*****	*****	*****	*****	*****	*****	
0.100	-0.0606	-0.0446	0.0929	*****	*****	*****	*****	*****	*****	
0.150	-0.0649	-0.0448	0.0797	*****	*****	*****	*****	*****	*****	
0.200	-0.0676	-0.0393	0.0680	*****	*****	*****	*****	*****	-0.4200	
0.250	*****	-0.0459	0.0536	-0.1665	-0.1665	-0.1665	-0.1665	-0.1665	-0.5981	
0.300	-0.0759	-0.0469	0.0427	-0.1525	-0.1525	-0.1525	-0.1525	-0.1525	-0.6678	
0.350	*****	-0.0510	0.0309	-0.1405	-0.1405	-0.1405	-0.1405	-0.1405	-0.6735	
0.400	-0.0989	-0.0531	0.0216	-0.1288	-0.1288	-0.1288	-0.1288	-0.1288	-0.6706	
0.450	-0.1096	-0.0601	0.0254	-0.1236	-0.1236	-0.1236	-0.1236	-0.1236	-0.6481	
0.500	-0.1210	-0.0625	-0.0026	-0.1191	-0.1191	-0.1191	-0.1191	-0.1191	-0.6505	
0.525	*****	-0.0707	-0.0058	-0.1194	-0.1194	-0.1194	-0.1194	-0.1194	-0.6647	
0.550	-0.1277	-0.0787	-0.0115	-0.1168	-0.1168	-0.1168	-0.1168	-0.1168	-0.6648	
0.575	*****	-0.0822	-0.0090	-0.1177	-0.1177	-0.1177	-0.1177	-0.1177	-0.6801	
0.600	-0.1411	-0.0886	-0.0252	-0.1207	-0.1207	-0.1207	-0.1207	-0.1207	-0.6865	
0.625	*****	*****	-0.0260	-0.1169	-0.1169	-0.1169	-0.1169	-0.1169	-0.6979	
0.650	-0.1488	-0.0960	-0.0352	-0.1182	-0.1182	-0.1182	-0.1182	-0.1182	-0.7206	
0.675	*****	-0.1125	-0.0464	-0.1240	-0.1240	-0.1240	-0.1240	-0.1240	-0.7286	
0.700	-0.1531	-0.1273	-0.0525	-0.1257	-0.1257	-0.1257	-0.1257	-0.1257	-0.7448	
0.725	*****	-0.1424	*****	-0.1289	-0.1289	-0.1289	-0.1289	-0.1289	-0.7490	
0.750	-0.1541	-0.1572	*****	-0.1331	-0.1331	-0.1331	-0.1331	-0.1331	-0.7484	
0.775	*****	-0.1712	-0.0968	-0.1475	-0.1475	-0.1475	-0.1475	-0.1475	-0.7361	
0.800	-0.1452	-0.1856	-0.1208	-0.1600	-0.1600	-0.1600	-0.1600	-0.1600	*****	
0.825	*****	-0.1966	-0.1478	-0.1616	-0.1616	-0.1616	-0.1616	-0.1616	-0.6607	
0.850	-0.1335	-0.2041	-0.1747	-0.2017	-0.2017	-0.2017	-0.2017	-0.2017	-0.4995	
0.875	*****	-0.2097	-0.2027	-0.2341	-0.2341	-0.2341	-0.2341	-0.2341	-0.4091	
0.900	-0.1129	-0.2120	-0.2232	-0.2714	-0.2714	-0.2714	-0.2714	-0.2714	-0.4051	
0.925	*****	-0.2071	-0.2366	-0.2981	-0.2981	-0.2981	-0.2981	-0.2981	-0.4619	
0.950	-0.0795	-0.1875	-0.2377	-0.3094	-0.3094	-0.3094	-0.3094	-0.3094	-0.5088	
0.975	*****	-0.1647	-0.2177	-0.2953	-0.2953	-0.2953	-0.2953	-0.2953	-0.4233	
1.000	0.1230	0.0374	-0.0184	-0.1043	-0.1043	-0.1043	-0.1043	-0.1043	-0.1246	
$C_{p,l}$	$C_{p,l}$	$C_{p,l}$	$C_{p,l}$	$C_{p,l}$	$C_{p,l}$	$C_{p,l}$	$C_{p,l}$	$C_{p,l}$	$C_{p,l}$	
-0.200	0.0432	0.0592	0.1309	*****	*****	*****	*****	*****	-0.6740	
-0.400	0.0273	0.0628	0.0944	-0.0659	-0.0659	-0.0659	-0.0659	-0.0659	-0.7271	
-0.600	0.0239	0.0521	0.0781	-0.0282	-0.0282	-0.0282	-0.0282	-0.0282	-0.7220	
-0.700	0.0356	0.0341	0.0644	-0.0194	-0.0194	-0.0194	-0.0194	-0.0194	-0.7019	
-0.800	0.0651	*****	0.0477	-0.0131	-0.0131	-0.0131	-0.0131	-0.0131	-0.6541	
-0.850	*****	0.0485	0.0416	-0.0178	-0.0178	-0.0178	-0.0178	-0.0178	-0.6730	
-0.900	*****	0.0798	0.0573	-0.0155	-0.0155	-0.0155	-0.0155	-0.0155	-0.7065	
-0.950	0.1773	0.1372	0.1145	0.0378	0.0378	0.0378	0.0378	0.0378	-0.2737	
-0.975	*****	0.1888	0.1652	0.0994	0.0994	0.0994	0.0994	0.0994	-0.1142	
-1.000	0.1098	0.0441	-0.0680	-0.0634	-0.0634	-0.0634	-0.0634	-0.0634	-0.0855	

Medium Radius L.E.
 Run No. = 27, Point No. = 534
 $C_N = 0.122$, $C_m = -0.0256$
 $\alpha = 2.8^\circ$, $M_\infty = 0.870$
 $R_{mac} = 59.8 \times 10^6$

Leading Edge Pressures

● starboard
 ○ port

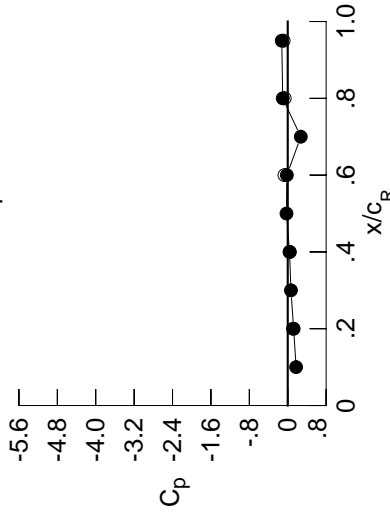

x/c_R	starb'd C_p	port C_p
0.10	0.1747	*****
0.20	0.1230	0.1098
0.30	0.0671	*****
0.40	0.0374	0.0441
0.50	-0.0259	*****
0.60	-0.0184	-0.0680
0.70	0.2722	*****
0.80	-0.1043	-0.0634
0.90	*****	*****
0.95	-0.1246	-0.0855

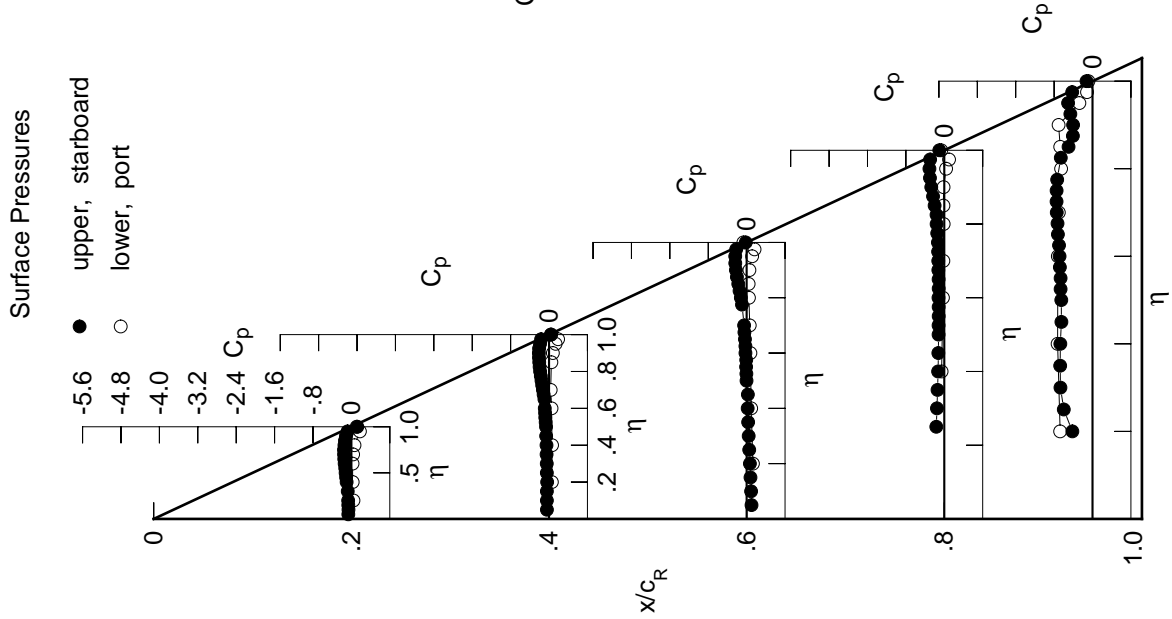

Table G3. Continued.

η	$x/c_R = .2$		$x/c_R = .4$		$x/c_R = .6$		$x/c_R = .8$		$x/c_R = .95$	
	$C_{p,u}$	$C_{p,u}$	$C_{p,u}$	$C_{p,u}$	$C_{p,u}$	$C_{p,u}$	$C_{p,u}$	$C_{p,u}$	$C_{p,u}$	$C_{p,u}$
0.050	-0.0809	-0.0589	0.0912	*****	0.0912	*****	0.0912	*****	0.0912	*****
0.100	-0.0781	-0.0600	0.0818	*****	0.0818	*****	0.0818	*****	0.0818	*****
0.150	-0.0828	-0.0599	0.0693	*****	0.0693	*****	0.0693	*****	0.0693	*****
0.200	-0.0850	-0.0548	0.0576	*****	0.0576	*****	0.0576	*****	0.0576	*****
0.250	*****	-0.0623	0.0421	-0.1781	-0.1781	-0.5662	-0.5662	-0.5662	-0.5662	-0.4161
0.300	-0.0944	-0.0633	0.0308	-0.1636	-0.1636	-0.6344	-0.6344	-0.6344	-0.6344	-0.6344
0.350	*****	-0.0687	0.0182	-0.1527	-0.1527	-0.6420	-0.6420	-0.6420	-0.6420	-0.6420
0.400	-0.1199	-0.0711	0.0086	-0.1409	-0.1409	-0.6338	-0.6338	-0.6338	-0.6338	-0.6338
0.450	-0.1319	-0.0790	0.0118	-0.1359	-0.1359	-0.6117	-0.6117	-0.6117	-0.6117	-0.6117
0.500	-0.1448	-0.0825	-0.0167	-0.1326	-0.1326	-0.6057	-0.6057	-0.6057	-0.6057	-0.6057
0.525	*****	-0.0909	-0.0209	-0.1333	-0.1333	-0.6209	-0.6209	-0.6209	-0.6209	-0.6209
0.550	-0.1542	-0.1004	-0.0274	-0.1312	-0.1312	-0.6176	-0.6176	-0.6176	-0.6176	-0.6176
0.575	*****	-0.1046	-0.0253	-0.1322	-0.1322	-0.6306	-0.6306	-0.6306	-0.6306	-0.6306
0.600	-0.1701	-0.1129	-0.0429	-0.1361	-0.1361	-0.6345	-0.6345	-0.6345	-0.6345	-0.6345
0.625	*****	*****	-0.0441	-0.1337	-0.1337	-0.6431	-0.6431	-0.6431	-0.6431	-0.6431
0.650	-0.1820	-0.1219	-0.0552	-0.1351	-0.1351	-0.6749	-0.6749	-0.6749	-0.6749	-0.6749
0.675	*****	-0.1396	-0.0677	-0.1423	-0.1423	-0.6941	-0.6941	-0.6941	-0.6941	-0.6941
0.700	-0.1892	-0.1575	-0.0752	-0.1452	-0.1452	-0.7292	-0.7292	-0.7292	-0.7292	-0.7292
0.725	*****	-0.1750	*****	-0.1495	-0.1495	-0.7479	-0.7479	-0.7479	-0.7479	-0.7479
0.750	-0.1939	-0.1934	*****	-0.1561	-0.1561	-0.7532	-0.7532	-0.7532	-0.7532	-0.7532
0.775	*****	-0.2108	-0.1272	-0.1724	-0.1724	-0.7284	-0.7284	-0.7284	-0.7284	-0.7284
0.800	-0.1894	-0.2303	-0.1554	-0.1891	-0.1891	*****	*****	*****	*****	*****
0.825	*****	-0.2458	-0.1877	-0.1931	-0.1931	-0.5963	-0.5963	-0.5963	-0.5963	-0.5963
0.850	-0.1844	-0.2592	-0.2217	-0.2387	-0.2387	-0.4135	-0.4135	-0.4135	-0.4135	-0.4135
0.875	*****	-0.2709	-0.2577	-0.2789	-0.2789	-0.3637	-0.3637	-0.3637	-0.3637	-0.3637
0.900	-0.1697	-0.2798	-0.2898	-0.3289	-0.3289	-0.3769	-0.3769	-0.3769	-0.3769	-0.3769
0.925	*****	-0.2837	-0.3146	-0.3700	-0.3700	-0.3988	-0.3988	-0.3988	-0.3988	-0.3988
0.950	-0.1473	-0.2753	-0.3324	-0.3992	-0.3992	-0.5639	-0.5639	-0.5639	-0.5639	-0.5639
0.975	*****	-0.2717	-0.3361	-0.4135	-0.4135	-0.5169	-0.5169	-0.5169	-0.5169	-0.5169
1.000	0.0342	-0.1199	-0.2245	-0.3306	-0.3306	-0.3014	-0.3014	-0.3014	-0.3014	-0.3014
-0.200	$C_{p,l}$	$C_{p,l}$	$C_{p,l}$	$C_{p,l}$	$C_{p,l}$	$C_{p,l}$	$C_{p,l}$	$C_{p,l}$	$C_{p,l}$	$C_{p,l}$
-0.400	0.0663	0.0791	0.1466	*****	0.1466	*****	0.1466	*****	0.1466	*****
-0.600	0.0522	0.0846	0.1108	-0.0414	-0.0414	-0.7200	-0.7200	-0.7200	-0.7200	-0.7200
-0.700	0.0533	0.0763	0.0971	-0.0119	-0.0119	-0.7121	-0.7121	-0.7121	-0.7121	-0.7121
-0.800	0.0683	0.0622	0.0868	-0.0010	-0.0010	-0.6903	-0.6903	-0.6903	-0.6903	-0.6903
-0.850	0.0997	*****	0.0751	0.0108	0.0108	-0.6385	-0.6385	-0.6385	-0.6385	-0.6385
-0.900	*****	0.0853	0.0750	0.0095	0.0095	-0.6526	-0.6526	-0.6526	-0.6526	-0.6526
-0.950	*****	0.1186	0.0949	0.0201	0.0201	-0.6702	-0.6702	-0.6702	-0.6702	-0.6702
-0.975	0.2051	0.1716	0.1512	0.0769	0.0769	-0.2512	-0.2512	-0.2512	-0.2512	-0.2512
-1.000	*****	0.2124	0.1924	0.1319	0.1319	-0.0871	-0.0871	-0.0871	-0.0871	-0.0871
-1.000	0.0231	-0.1082	-0.2866	-0.2753	-0.2753	-0.2345	-0.2345	-0.2345	-0.2345	-0.2345

Medium Radius L.E.
 Run No. = 27, Point No. = 535
 $C_N = 0.164$, $C_m = -0.0326$
 $\alpha = 3.9^\circ$, $M_\infty = 0.869$
 $R_{mac} = 59.9 \times 10^6$

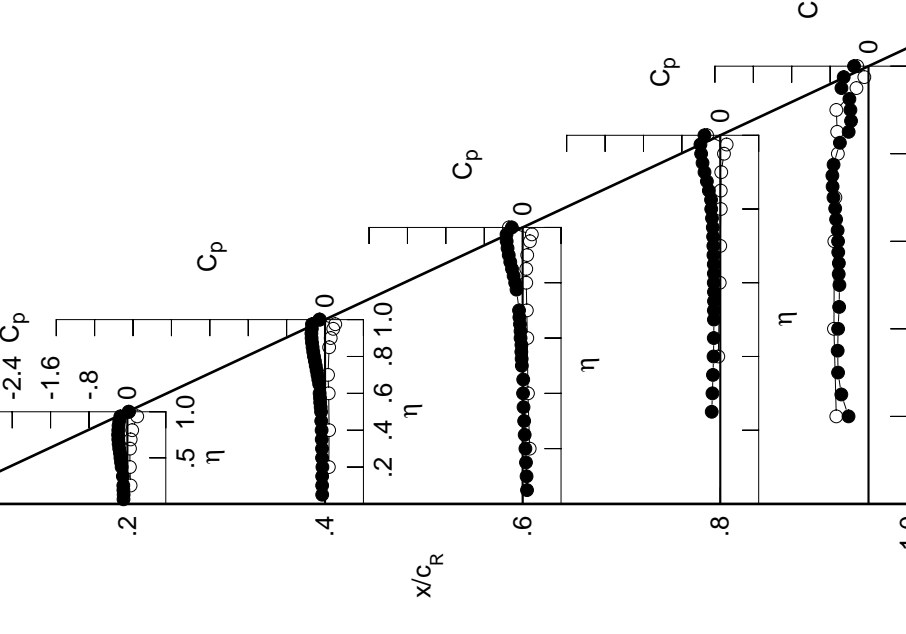
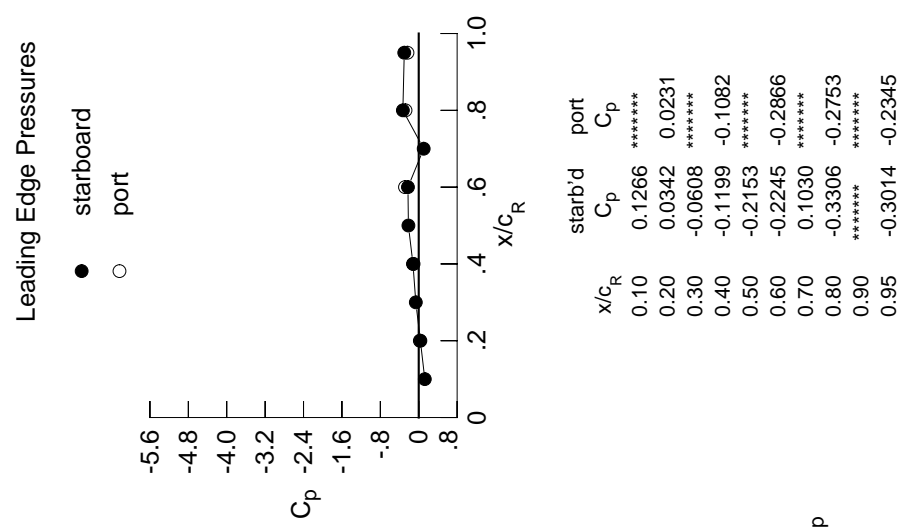
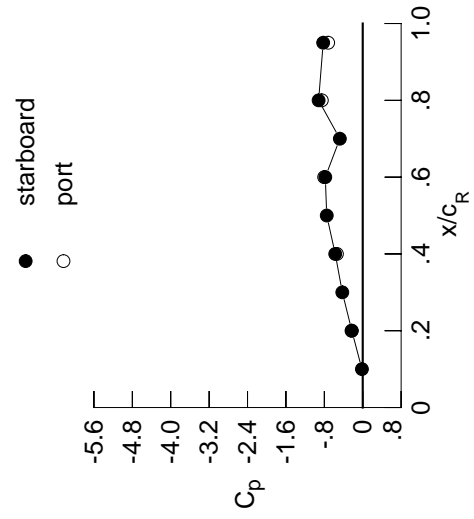

Table G3. Continued.

η	$x/c_R = .2$		$x/c_R = .4$		$x/c_R = .6$		$x/c_R = .8$		$x/c_R = .95$	
	$C_{p,u}$	$C_{p,u}$	$C_{p,u}$	$C_{p,u}$	$C_{p,u}$	$C_{p,u}$	$C_{p,u}$	$C_{p,u}$	$C_{p,u}$	$C_{p,u}$
0.050	-0.1178	-0.0936	0.0683	0.0683	0.0683	0.0683	0.0683	0.0683	0.0683	0.0683
0.100	-0.1168	-0.0940	0.0588	0.0588	0.0588	0.0588	0.0588	0.0588	0.0588	0.0588
0.150	-0.1211	-0.0958	0.0458	0.0458	0.0458	0.0458	0.0458	0.0458	0.0458	0.0458
0.200	-0.1248	-0.0908	0.0333	0.0333	0.0333	0.0333	0.0333	0.0333	0.0333	0.0333
0.250	0.0000	-0.0995	0.0173	-0.2064	-0.1921	-0.5587	-0.5587	-0.5587	-0.5587	-0.5587
0.300	-0.1354	-0.1013	0.0052	-0.1921	-0.1812	-0.5710	-0.5710	-0.5710	-0.5710	-0.5710
0.350	0.0000	-0.1085	-0.0090	-0.1812	-0.1705	-0.5759	-0.5759	-0.5759	-0.5759	-0.5759
0.400	-0.1657	-0.1122	-0.0206	-0.1705	-0.1643	-0.5756	-0.5756	-0.5756	-0.5756	-0.5756
0.450	-0.1805	-0.1224	-0.0191	-0.1664	-0.1643	-0.5756	-0.5756	-0.5756	-0.5756	-0.5756
0.500	-0.1980	-0.1283	-0.0497	-0.1645	-0.1645	-0.5542	-0.5542	-0.5542	-0.5542	-0.5542
0.525	0.0000	-0.1393	-0.0552	-0.1646	-0.1646	-0.5762	-0.5762	-0.5762	-0.5762	-0.5762
0.550	-0.2127	-0.1500	-0.0633	-0.1643	-0.1643	-0.5756	-0.5756	-0.5756	-0.5756	-0.5756
0.575	0.0000	-0.1564	-0.0635	-0.1676	-0.1676	-0.5896	-0.5896	-0.5896	-0.5896	-0.5896
0.600	-0.2338	-0.1672	-0.0825	-0.1726	-0.1726	-0.6030	-0.6030	-0.6030	-0.6030	-0.6030
0.625	0.0000	0.0000	-0.0871	-0.1717	-0.1717	-0.6425	-0.6425	-0.6425	-0.6425	-0.6425
0.650	-0.2535	-0.1805	-0.0993	-0.1765	-0.1765	-0.6813	-0.6813	-0.6813	-0.6813	-0.6813
0.675	0.0000	-0.2026	-0.1150	-0.1866	-0.1866	-0.6858	-0.6858	-0.6858	-0.6858	-0.6858
0.700	-0.2688	-0.2249	-0.1261	-0.1923	-0.1923	-0.7034	-0.7034	-0.7034	-0.7034	-0.7034
0.725	0.0000	-0.2483	0.0000	-0.2021	-0.2021	-0.7219	-0.7219	-0.7219	-0.7219	-0.7219
0.750	-0.2833	-0.2742	0.0000	-0.2149	-0.2149	-0.6928	-0.6928	-0.6928	-0.6928	-0.6928
0.775	0.0000	-0.3001	-0.1959	-0.2384	-0.2384	-0.5966	-0.5966	-0.5966	-0.5966	-0.5966
0.800	-0.2911	-0.3288	-0.2319	-0.2597	-0.2597	0.0000	0.0000	0.0000	0.0000	0.0000
0.825	0.0000	-0.3569	-0.2752	-0.2702	-0.2702	-0.4838	-0.4838	-0.4838	-0.4838	-0.4838
0.850	-0.2981	-0.3833	-0.3231	-0.3207	-0.3207	-0.3419	-0.3419	-0.3419	-0.3419	-0.3419
0.875	0.0000	-0.4117	-0.3794	-0.3768	-0.3768	-0.3335	-0.3335	-0.3335	-0.3335	-0.3335
0.900	-0.3032	-0.4390	-0.4374	-0.4498	-0.4498	-0.3496	-0.3496	-0.3496	-0.3496	-0.3496
0.925	0.0000	-0.4671	-0.4933	-0.5277	-0.5277	-0.3500	-0.3500	-0.3500	-0.3500	-0.3500
0.950	-0.3100	-0.4868	-0.5546	-0.6126	-0.6126	-0.6868	-0.6868	-0.6868	-0.6868	-0.6868
0.975	0.0000	-0.5459	-0.6296	-0.6943	-0.6943	-0.7650	-0.7650	-0.7650	-0.7650	-0.7650
1.000	-0.2270	-0.5726	-0.7797	-0.9192	-0.9192	-0.8237	-0.8237	-0.8237	-0.8237	-0.8237
-0.200	$C_{p,l}$	0.1101	0.1184	0.1758	0.1758	0.1758	0.1758	0.1758	0.1758	0.1758
-0.400	$C_{p,l}$	0.1011	0.1241	0.1439	0.1439	0.1439	0.1439	0.1439	0.1439	0.1439
-0.600	$C_{p,l}$	0.1097	0.1224	0.1336	0.1336	0.1336	0.1336	0.1336	0.1336	0.1336
-0.700	$C_{p,l}$	0.1288	0.1152	0.1287	0.1287	0.1287	0.1287	0.1287	0.1287	0.1287
-0.800	$C_{p,l}$	0.1620	0.1620	0.1620	0.1620	0.1620	0.1620	0.1620	0.1620	0.1620
-0.850	$C_{p,l}$	0.1515	0.1515	0.1515	0.1515	0.1515	0.1515	0.1515	0.1515	0.1515
-0.900	$C_{p,l}$	0.1830	0.1830	0.1830	0.1830	0.1830	0.1830	0.1830	0.1830	0.1830
-0.950	$C_{p,l}$	0.2415	0.2183	0.2014	0.2014	0.2014	0.2014	0.2014	0.2014	0.2014
-0.975	$C_{p,l}$	0.2238	0.2238	0.2118	0.2118	0.2118	0.2118	0.2118	0.2118	0.2118
-1.000	$C_{p,l}$	-0.2334	-0.5376	-0.8042	-0.8519	-0.8519	-0.8519	-0.8519	-0.8519	-0.8519

Medium Radius L.E.
 Run No. = 27, Point No. = 537
 $C_N = 0.253$, $C_m = -0.0483$
 $\alpha = 6.0^\circ$, $M_\infty = 0.870$
 $R_{mac} = 59.8 \times 10^6$

Leading Edge Pressures



x/c_R	starb'd C_p	port C_p
0.10	-0.0170	0.0000
0.20	-0.2270	-0.2334
0.30	-0.4253	0.0000
0.40	-0.5726	-0.5376
0.50	-0.7500	0.0000
0.60	-0.7797	-0.8042
0.70	-0.4767	0.0000
0.80	-0.9192	-0.8519
0.90	0.0000	0.0000
0.95	-0.8237	-0.7202

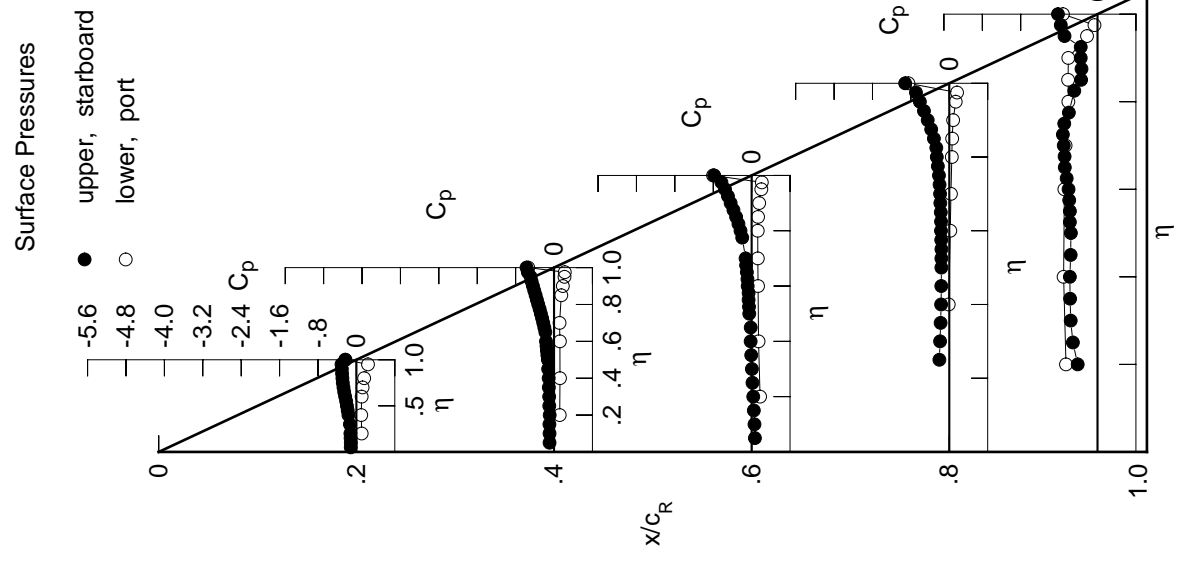
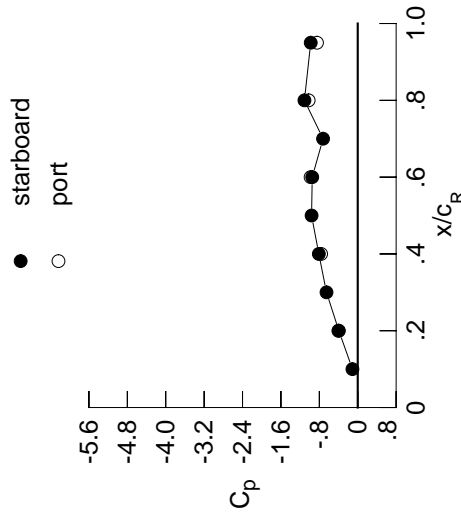

Table G3. Continued.

η	$x/c_R = .2$		$x/c_R = .4$		$x/c_R = .6$		$x/c_R = .8$		$x/c_R = .95$	
	$C_{p,u}$	$C_{p,l}$	$C_{p,u}$	$C_{p,l}$	$C_{p,u}$	$C_{p,l}$	$C_{p,u}$	$C_{p,l}$	$C_{p,u}$	$C_{p,l}$
0.050	-0.1351	-0.1102	0.0569	*****	*****	*****	*****	*****	*****	*****
0.100	-0.1358	-0.1117	0.0468	*****	*****	*****	*****	*****	*****	*****
0.150	-0.1400	-0.1131	0.0340	*****	*****	*****	*****	*****	*****	*****
0.200	-0.1448	-0.1087	0.0208	*****	*****	*****	*****	*****	*****	*****
0.250	*****	-0.1173	0.0044	-0.2197	-0.4743	*****	*****	*****	*****	-0.4180
0.300	-0.1548	-0.1203	-0.0085	-0.2057	-0.5134	*****	*****	*****	*****	*****
0.350	*****	-0.1276	-0.0223	-0.1961	-0.5272	*****	*****	*****	*****	*****
0.400	-0.1873	-0.1319	-0.0352	-0.1847	-0.5394	*****	*****	*****	*****	*****
0.450	-0.2040	-0.1443	-0.0348	-0.1813	-0.5566	*****	*****	*****	*****	*****
0.500	-0.2238	-0.1517	-0.0658	-0.1790	-0.6389	*****	*****	*****	*****	*****
0.525	*****	-0.1631	-0.0726	-0.1800	-0.6877	*****	*****	*****	*****	*****
0.550	-0.2407	-0.1750	-0.0813	-0.1787	-0.6936	*****	*****	*****	*****	*****
0.575	*****	-0.1821	-0.0818	-0.1839	-0.7012	*****	*****	*****	*****	*****
0.600	-0.2657	-0.1949	-0.1037	-0.1920	-0.6906	*****	*****	*****	*****	*****
0.625	*****	*****	-0.1087	-0.1974	-0.6799	*****	*****	*****	*****	*****
0.650	-0.2891	-0.2108	-0.1255	-0.2068	-0.6715	*****	*****	*****	*****	*****
0.675	*****	-0.2345	-0.1441	-0.2199	-0.6290	*****	*****	*****	*****	*****
0.700	-0.3097	-0.2588	-0.1605	-0.2324	-0.5730	*****	*****	*****	*****	*****
0.725	*****	-0.2852	*****	-0.2444	-0.5075	*****	*****	*****	*****	*****
0.750	-0.3296	-0.3138	*****	-0.2584	-0.4357	*****	*****	*****	*****	*****
0.775	*****	-0.3450	-0.2325	-0.2774	-0.3490	*****	*****	*****	*****	*****
0.800	-0.3437	-0.3794	-0.2670	-0.2983	*****	*****	*****	*****	*****	*****
0.825	*****	-0.4141	-0.3111	-0.3102	-0.3237	*****	*****	*****	*****	*****
0.850	-0.3588	-0.4479	-0.3628	-0.3542	-0.3306	*****	*****	*****	*****	*****
0.875	*****	-0.4860	-0.4265	-0.4073	-0.3898	*****	*****	*****	*****	*****
0.900	-0.3732	-0.5256	-0.4965	-0.4925	-0.5945	*****	*****	*****	*****	*****
0.925	*****	-0.5687	-0.5678	-0.5811	-0.9978	*****	*****	*****	*****	*****
0.950	-0.4039	-0.6048	-0.6448	-0.6752	-0.6055	*****	*****	*****	*****	*****
0.975	*****	-0.6950	-0.7404	-0.8428	-0.7385	*****	*****	*****	*****	*****
1.000	-0.3933	-0.8105	-0.9480	-1.1107	-0.9795	*****	*****	*****	*****	*****
-0.200	$C_{p,l}$	0.1333	0.1377	0.1904	*****	*****	*****	*****	*****	-0.6462
-0.400		0.1252	0.1449	0.1592	0.0019	-0.7013	*****	*****	*****	*****
-0.600		0.1373	0.1444	0.1503	0.0349	-0.6799	*****	*****	*****	*****
-0.700		0.1569	0.1401	0.1474	0.0501	-0.6545	*****	*****	*****	*****
-0.800		0.1893	*****	0.1487	0.0707	-0.5930	*****	*****	*****	*****
-0.850	*****	0.1787	0.1572	0.0804	-0.5962	*****	*****	*****	*****	*****
-0.900	*****	0.2076	0.1808	0.1028	-0.5831	*****	*****	*****	*****	*****
-0.950		0.2496	0.2316	0.2149	0.1502	-0.2060	*****	*****	*****	*****
-0.975	*****	0.2164	0.2075	0.1629	-0.0560	*****	*****	*****	*****	*****
-1.000		-0.4034	-0.7624	-0.9812	-1.0228	-0.8485	*****	*****	*****	*****

Medium Radius L.E.
 Run No. = 27, Point No. = 538
 $C_N = 0.298$, $C_m = -0.0553$
 $\alpha = 7.0^\circ$, $M_\infty = 0.870$
 $R_{mac} = 59.9 \times 10^6$

Leading Edge Pressures



x/c_R	starb'd C_p	port C_p
0.10	-0.1102	*****
0.20	-0.3933	-0.4034
0.30	-0.6508	*****
0.40	-0.8105	-0.7624
0.50	-0.9618	*****
0.60	-0.9480	-0.9812
0.70	-0.7223	*****
0.80	-1.1107	-1.0228
0.90	*****	*****
0.95	-0.9795	-0.8485

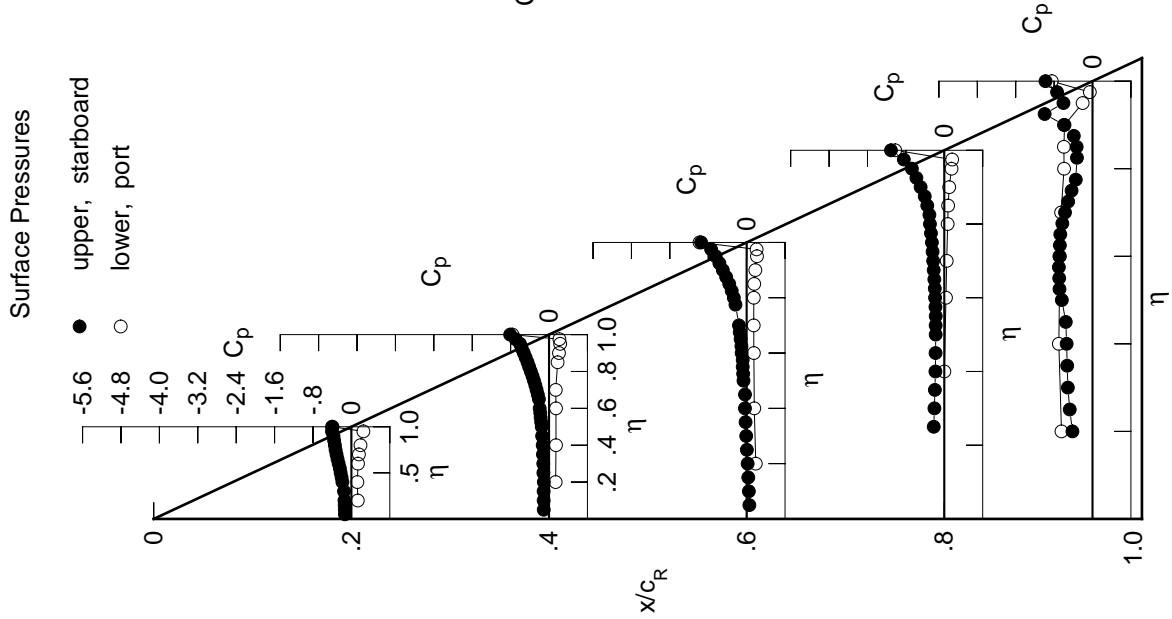
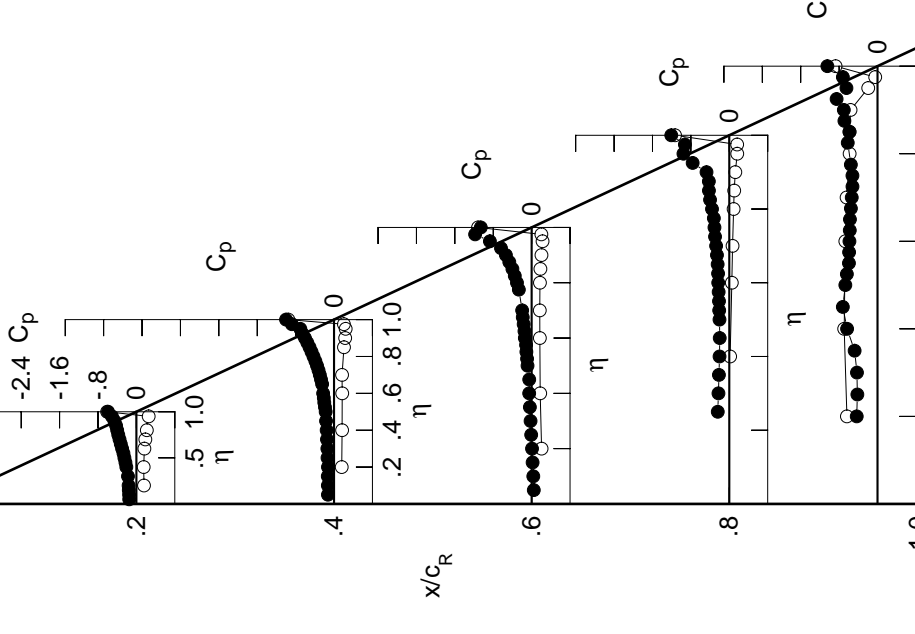
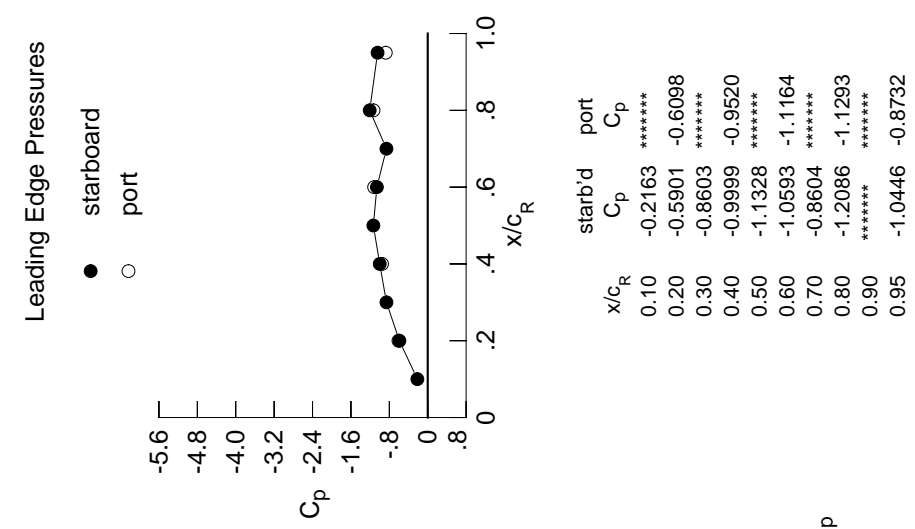

Table G3. Continued.

η	$x/c_R = .2$		$x/c_R = .4$		$x/c_R = .6$		$x/c_R = .8$		$x/c_R = .95$	
	$C_{p,u}$	$C_{p,u}$	$C_{p,u}$	$C_{p,u}$	$C_{p,u}$	$C_{p,u}$	$C_{p,u}$	$C_{p,u}$	$C_{p,u}$	$C_{p,u}$
0.050	-0.1499	-0.1272	0.0446	*****	*****	*****	*****	*****	*****	*****
0.100	-0.1521	-0.1289	0.0340	*****	*****	*****	*****	*****	*****	*****
0.150	-0.1581	-0.1307	0.0201	*****	*****	*****	*****	*****	*****	*****
0.200	-0.1625	-0.1262	0.0076	*****	*****	*****	*****	*****	*****	-0.4326
0.250	*****	-0.1356	-0.0097	-0.2403	-0.4202	*****	*****	*****	*****	*****
0.300	-0.1750	-0.1393	-0.0228	-0.2257	-0.4283	*****	*****	*****	*****	*****
0.350	*****	-0.1476	-0.0371	-0.2156	-0.4770	*****	*****	*****	*****	*****
0.400	-0.2092	-0.1535	-0.0511	-0.2033	-0.6335	*****	*****	*****	*****	*****
0.450	-0.2277	-0.1667	-0.0505	-0.1994	-0.7227	*****	*****	*****	*****	*****
0.500	-0.2493	-0.1747	-0.0856	-0.2039	-0.6708	*****	*****	*****	*****	*****
0.525	*****	-0.1886	-0.0953	-0.2107	-0.6388	*****	*****	*****	*****	*****
0.550	-0.2696	-0.2028	-0.1095	-0.2147	-0.5956	*****	*****	*****	*****	*****
0.575	*****	-0.2127	-0.1161	-0.2217	-0.5923	*****	*****	*****	*****	*****
0.600	-0.2974	-0.2273	-0.1416	-0.2301	-0.5849	*****	*****	*****	*****	*****
0.625	*****	*****	-0.1497	-0.2338	-0.5777	*****	*****	*****	*****	*****
0.650	-0.3249	-0.2477	-0.1668	-0.2427	-0.5744	*****	*****	*****	*****	*****
0.675	*****	-0.2713	-0.1850	-0.2568	-0.5543	*****	*****	*****	*****	*****
0.700	-0.3510	-0.2963	-0.1974	-0.2742	-0.5370	*****	*****	*****	*****	*****
0.725	*****	-0.3236	*****	-0.2964	-0.5219	*****	*****	*****	*****	*****
0.750	-0.3776	-0.3544	*****	-0.3089	-0.5220	*****	*****	*****	*****	*****
0.775	*****	-0.3886	-0.2663	-0.3219	-0.5549	*****	*****	*****	*****	*****
0.800	-0.3998	-0.4280	-0.3058	-0.3603	*****	*****	*****	*****	*****	*****
0.825	*****	-0.4684	-0.3513	-0.4011	-0.6202	*****	*****	*****	*****	*****
0.850	-0.4234	-0.5104	-0.4005	-0.4239	-0.5859	*****	*****	*****	*****	*****
0.875	*****	-0.5569	-0.4652	-0.4253	-0.6899	*****	*****	*****	*****	*****
0.900	-0.4566	-0.6061	-0.5361	-0.4745	-0.7017	*****	*****	*****	*****	*****
0.925	*****	-0.6630	-0.6382	-0.7634	-0.8521	*****	*****	*****	*****	*****
0.950	-0.5106	-0.7025	-0.8693	-0.9650	-0.6470	*****	*****	*****	*****	*****
0.975	*****	-0.8786	-1.1779	-0.9247	-0.7215	*****	*****	*****	*****	*****
1.000	-0.5901	-0.9999	-1.0593	-1.2086	-1.0446	*****	*****	*****	*****	*****
-0.200	$C_{p,l}$	0.1586	0.1604	0.2073	*****	*****	*****	*****	*****	-0.6372
-0.400	$C_{p,l}$	0.1521	0.1679	0.1782	0.0178	-0.6941	*****	*****	*****	*****
-0.600	$C_{p,l}$	0.1664	0.1703	0.1710	0.0528	-0.6706	*****	*****	*****	*****
-0.700	$C_{p,l}$	0.1865	0.1670	0.1693	0.0683	-0.6438	*****	*****	*****	*****
-0.800	$C_{p,l}$	0.2179	*****	0.1730	0.0901	-0.5807	*****	*****	*****	*****
-0.850	$C_{p,l}$	*****	0.2069	0.1824	0.1022	-0.5808	*****	*****	*****	*****
-0.900	$C_{p,l}$	*****	0.2322	0.2047	0.1254	-0.5615	*****	*****	*****	*****
-0.950	$C_{p,l}$	0.2561	0.2422	0.2274	0.1657	-0.1934	*****	*****	*****	*****
-0.975	$C_{p,l}$	*****	0.2060	0.2026	0.1641	-0.0484	*****	*****	*****	*****
-1.000	$C_{p,l}$	-0.6098	-0.9520	-1.1164	-1.1293	-0.8732	*****	*****	*****	*****

Medium Radius L.E.
 Run No. = 27, Point No. = 539
 $C_N = 0.351$, $C_m = -0.0668$
 $\alpha = 8.1^\circ$, $M_\infty = 0.868$
 $R_{mac} = 59.8 \times 10^6$



x/c_R	starb'd C_p	port C_p
0.10	-0.2163	*****
0.20	-0.5901	-0.6098
0.30	-0.8603	*****
0.40	-0.9999	-0.9520
0.50	-1.1328	*****
0.60	-1.0593	-1.1164
0.70	-0.8604	*****
0.80	-1.2086	-1.1293
0.90	*****	*****
0.95	-1.0446	-0.8732

Table G3. Continued.

η	$x/c_R = .2$		$x/c_R = .4$		$x/c_R = .6$		$x/c_R = .8$		$x/c_R = .95$	
	$C_{p,u}$	$C_{p,u}$	$C_{p,u}$	$C_{p,u}$	$C_{p,u}$	$C_{p,u}$	$C_{p,u}$	$C_{p,u}$	$C_{p,u}$	$C_{p,u}$
0.050	-0.1647	-0.1445	0.0285	*****	*****	*****	*****	*****	*****	
0.100	-0.1699	-0.1477	0.0170	*****	*****	*****	*****	*****	*****	
0.150	-0.1755	-0.1499	0.0036	*****	*****	*****	*****	*****	*****	
0.200	-0.1822	-0.1459	-0.0102	*****	*****	*****	*****	*****	-0.3743	
0.250	*****	-0.1561	-0.0279	-0.2709	-0.2709	-0.2745	*****	*****	*****	
0.300	-0.1945	-0.1601	-0.0401	-0.2543	-0.2543	-0.3215	*****	*****	*****	
0.350	*****	-0.1689	-0.0529	-0.2402	-0.2402	-0.5792	*****	*****	*****	
0.400	-0.2310	-0.1753	-0.0677	-0.2306	-0.2306	-0.7560	*****	*****	*****	
0.450	-0.2514	-0.1897	-0.0763	-0.2392	-0.2392	-0.7372	*****	*****	*****	
0.500	-0.2745	-0.2048	-0.1244	-0.2399	-0.2399	-0.6698	*****	*****	*****	
0.525	*****	-0.2230	-0.1378	-0.2435	-0.2435	-0.6450	*****	*****	*****	
0.550	-0.2975	-0.2417	-0.1506	-0.2507	-0.2507	-0.6052	*****	*****	*****	
0.575	*****	-0.2517	-0.1565	-0.2661	-0.2661	-0.6129	*****	*****	*****	
0.600	-0.3288	-0.2662	-0.1783	-0.2759	-0.2759	-0.6356	*****	*****	*****	
0.625	*****	*****	-0.1807	-0.2693	-0.2693	-0.6562	*****	*****	*****	
0.650	-0.3603	-0.2846	-0.2000	-0.2689	-0.2689	-0.6473	*****	*****	*****	
0.675	*****	-0.3059	-0.2224	-0.2879	-0.2879	-0.5977	*****	*****	*****	
0.700	-0.3913	-0.3280	-0.2313	-0.3331	-0.3331	-0.5733	*****	*****	*****	
0.725	*****	-0.3549	*****	-0.3929	-0.3929	-0.5685	*****	*****	*****	
0.750	-0.4230	-0.3870	*****	-0.4163	-0.4163	-0.5549	*****	*****	*****	
0.775	*****	-0.4227	-0.3262	-0.4514	-0.4514	-0.5570	*****	*****	*****	
0.800	-0.4606	-0.4674	-0.3650	-0.5196	-0.5196	*****	*****	*****	*****	
0.825	*****	-0.5133	-0.3791	-0.5846	-0.5846	-0.5667	*****	*****	*****	
0.850	-0.4935	-0.5600	-0.3625	-0.5460	-0.5460	-0.5299	*****	*****	*****	
0.875	*****	-0.6116	-0.5173	-0.5064	-0.5064	-0.5614	*****	*****	*****	
0.900	-0.5323	-0.6636	-0.8946	-0.5404	-0.7528	*****	*****	*****	*****	
0.925	*****	-0.7078	-0.9949	-0.8856	-0.7882	*****	*****	*****	*****	
0.950	-0.6137	-0.8958	-0.8458	-0.9145	-0.6285	*****	*****	*****	*****	
0.975	*****	-1.3430	-1.2952	-0.8372	-0.8334	*****	*****	*****	*****	
1.000	-0.7595	-1.1250	-1.1257	-1.2696	-1.1300	*****	*****	*****	*****	
-0.200	$C_{p,l}$	0.1835	0.1822	0.2248	*****	-0.6231	*****	*****	*****	
-0.400	$C_{p,l}$	0.1786	0.1906	0.1957	0.0333	-0.6824	*****	*****	*****	
-0.600	$C_{p,l}$	0.1948	0.1944	0.1905	0.0689	-0.6564	*****	*****	*****	
-0.700	$C_{p,l}$	0.2160	0.1933	0.1896	0.0862	-0.6299	*****	*****	*****	
-0.800	$C_{p,l}$	0.2444	*****	0.1950	0.1086	-0.5657	*****	*****	*****	
-0.850	$C_{p,l}$	*****	0.2329	0.2046	0.1223	-0.5656	*****	*****	*****	
-0.900	$C_{p,l}$	*****	0.2526	0.2240	0.1454	-0.5435	*****	*****	*****	
-0.950	$C_{p,l}$	0.2580	0.2493	0.2347	0.1783	-0.1920	*****	*****	*****	
-0.975	$C_{p,l}$	*****	0.1933	0.1939	0.1640	-0.0621	*****	*****	*****	
-1.000	$C_{p,l}$	-0.7955	-1.0714	-1.1853	-1.1639	-0.9915	*****	*****	*****	

Medium Radius L.E.
 Run No. = 27 , Point No. = 540
 $C_N = 0.409$, $C_m = -0.0788$
 $\alpha = 9.1^\circ$, $M_\infty = 0.870$
 $R_{mac} = 59.7 \times 10^6$

Leading Edge Pressures

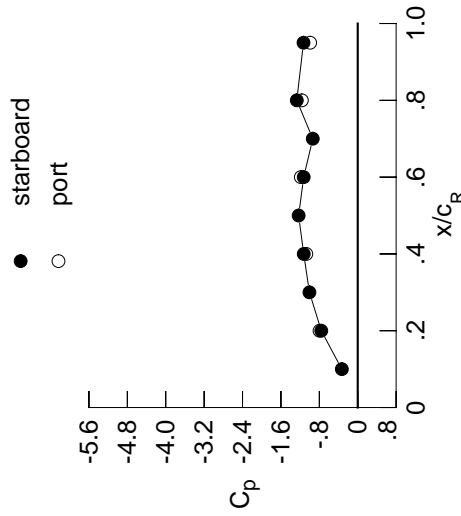

x/c_R	starb'd C_p	port C_p
0.10	-0.3314	*****
0.20	-0.7595	-0.7955
0.30	-1.0062	*****
0.40	-1.1250	-1.0714
0.50	-1.2314	*****
0.60	-1.1257	-1.1853
0.70	-0.9365	*****
0.80	-1.2696	-1.1639
0.90	*****	*****
0.95	-1.1300	-0.9915

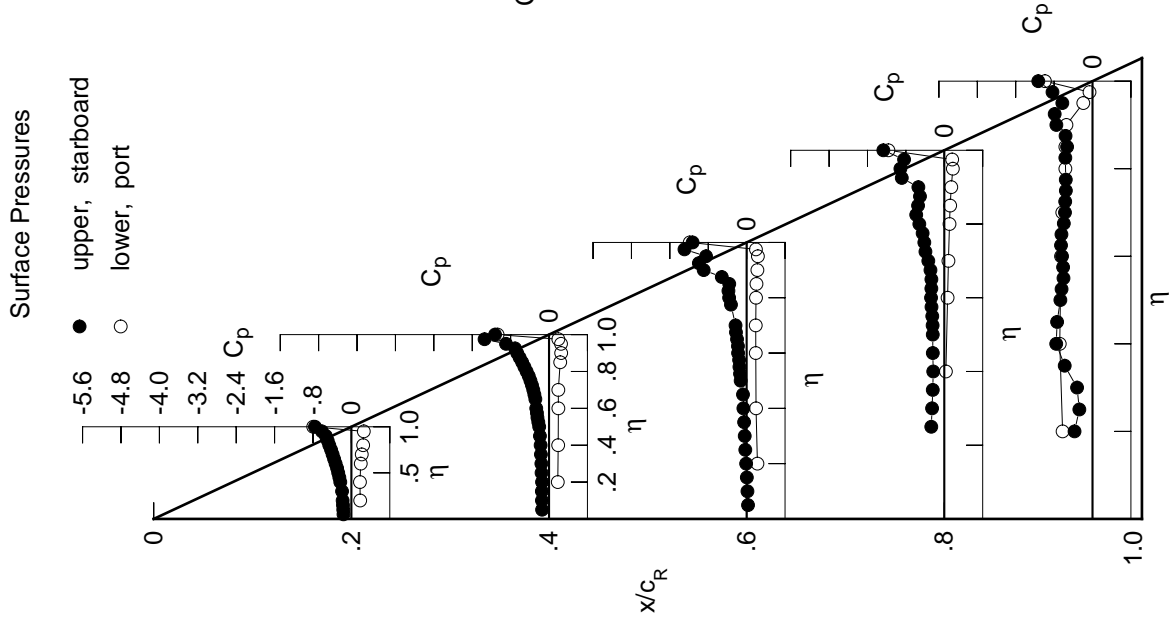
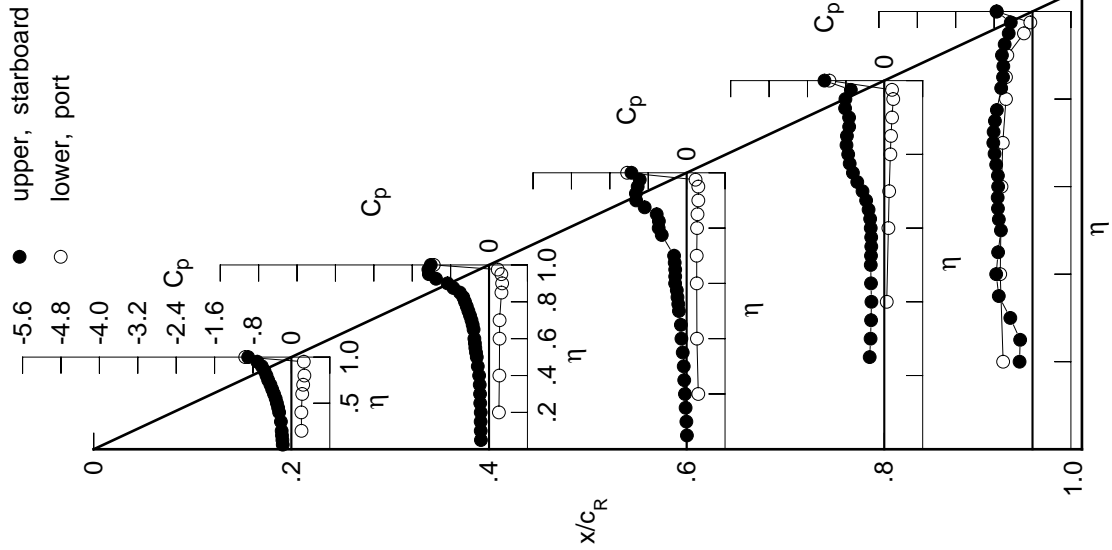

Table G3. Continued.

η	x/c_R .2	x/c_R .4	x/c_R .6	x/c_R .8	x/c_R .95
	$C_{p,u}$	$C_{p,u}$	$C_{p,u}$	$C_{p,u}$	$C_{p,u}$
0.050	-0.1799	-0.1687	0.0053	*****	*****
0.100	-0.1875	-0.1725	-0.0059	*****	*****
0.150	-0.1958	-0.1746	-0.0215	*****	*****
0.200	-0.2023	-0.1727	-0.0352	*****	-0.2698
0.250	*****	-0.1831	-0.0502	-0.3039	-0.2573
0.300	-0.2180	-0.1872	-0.0607	-0.2857	-0.4628
0.350	*****	-0.1937	-0.0815	-0.2754	-0.7022
0.400	-0.2551	-0.2062	-0.1090	-0.2678	-0.7570
0.450	-0.2763	-0.2341	-0.1198	-0.2765	-0.7167
0.500	-0.3019	-0.2551	-0.1609	-0.2819	-0.6580
0.525	*****	-0.2709	-0.1742	-0.2767	-0.7015
0.550	-0.3276	-0.2857	-0.1910	-0.2714	-0.7198
0.575	*****	-0.2943	-0.2045	-0.2730	-0.7255
0.600	-0.3627	-0.3053	-0.2396	-0.2823	-0.7158
0.625	*****	*****	-0.2388	-0.2944	-0.7209
0.650	-0.3998	-0.3212	-0.2381	-0.3270	-0.7564
0.675	*****	-0.3409	-0.2492	-0.3787	-0.7906
0.700	-0.4369	-0.3659	-0.2612	-0.4534	-0.8164
0.725	*****	-0.3963	*****	-0.5635	-0.8102
0.750	-0.4840	-0.4303	*****	-0.6535	-0.7835
0.775	*****	-0.4639	-0.5181	-0.7210	-0.7426
0.800	-0.5193	-0.5005	-0.5827	-0.7521	*****
0.825	*****	-0.5379	-0.5787	-0.7876	-0.6525
0.850	-0.5603	-0.6076	-0.6242	-0.7781	-0.6142
0.875	*****	-0.7427	-0.8742	-0.7320	-0.6082
0.900	-0.6159	-0.8641	-1.0523	-0.7335	-0.6367
0.925	*****	-1.1046	-1.0575	-0.8166	-0.5798
0.950	-0.7113	-1.2537	-1.0200	-0.8094	-0.4964
0.975	*****	-1.2638	-0.9765	-0.6965	-0.4530
1.000	-0.9011	-1.2143	-1.1495	-1.2462	-0.7449
	$C_{p,l}$	$C_{p,l}$	$C_{p,l}$	$C_{p,l}$	$C_{p,l}$
-0.200	0.2108	0.2056	0.2427	*****	-0.6119
-0.400	0.2071	0.2148	0.2141	0.0510	-0.6724
-0.600	0.2254	0.2196	0.2101	0.0854	-0.6463
-0.700	0.2456	0.2202	0.2100	0.1020	-0.6191
-0.800	0.2706	*****	0.2170	0.1264	-0.5526
-0.850	*****	0.2582	0.2265	0.1398	-0.5526
-0.900	*****	0.2731	0.2436	0.1616	-0.5245
-0.950	0.2584	0.2557	0.2429	0.1867	-0.1783
-0.975	*****	0.1815	0.1860	0.1611	-0.0455
-1.000	-0.9617	-1.1513	-1.2396	-1.1435	-0.7497

Surface Pressures



Medium Radius L.E.
 Run No. = 27, Point No. = 541
 $C_N = 0.471$, $C_m = -0.0910$
 $\alpha = 10.2^\circ$, $M_\infty = 0.870$
 $R_{mac} = 59.8 \times 10^6$

Leading Edge Pressures

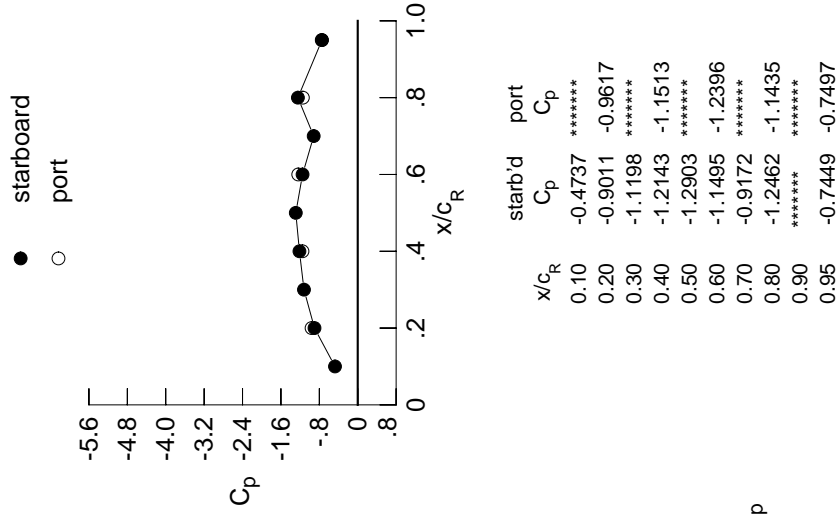
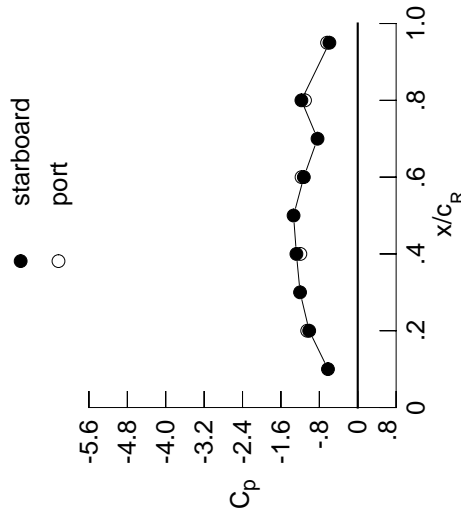

Table G3. Continued.

η	$x/c_R = .2$		$x/c_R = .4$		$x/c_R = .6$		$x/c_R = .8$		$x/c_R = .95$	
	$C_{p,u}$	$C_{p,u}$	$C_{p,u}$	$C_{p,u}$	$C_{p,u}$	$C_{p,u}$	$C_{p,u}$	$C_{p,u}$	$C_{p,u}$	$C_{p,u}$
0.050	-0.1935	-0.1965	-0.0205	*****	*****	*****	*****	*****	*****	*****
0.100	-0.2013	-0.1991	-0.0328	*****	*****	*****	*****	*****	*****	*****
0.150	-0.2143	-0.2025	-0.0485	*****	*****	*****	*****	*****	*****	*****
0.200	-0.2218	-0.2016	-0.0580	*****	*****	*****	*****	*****	*****	-0.2493
0.250	*****	-0.2092	-0.0742	-0.3279	-0.3279	-0.3279	-0.3279	-0.3279	-0.3279	-0.3279
0.300	-0.2403	-0.2107	-0.0937	-0.3124	-0.3124	-0.3124	-0.3124	-0.3124	-0.3124	-0.3124
0.350	*****	-0.2304	-0.1141	-0.3003	-0.3003	-0.3003	-0.3003	-0.3003	-0.3003	-0.3003
0.400	-0.2792	-0.2532	-0.1396	-0.2960	-0.2960	-0.2960	-0.2960	-0.2960	-0.2960	-0.2960
0.450	-0.3025	-0.2758	-0.1627	-0.2928	-0.2928	-0.2928	-0.2928	-0.2928	-0.2928	-0.2928
0.500	-0.3316	-0.2964	-0.2027	-0.3082	-0.3082	-0.3082	-0.3082	-0.3082	-0.3082	-0.3082
0.525	*****	-0.3077	-0.2088	-0.3180	-0.3180	-0.3180	-0.3180	-0.3180	-0.3180	-0.3180
0.550	-0.3601	-0.3150	-0.2214	-0.3190	-0.3190	-0.3190	-0.3190	-0.3190	-0.3190	-0.3190
0.575	*****	-0.3164	-0.2403	-0.3213	-0.3213	-0.3213	-0.3213	-0.3213	-0.3213	-0.3213
0.600	-0.3962	-0.3282	-0.3025	-0.3290	-0.3290	-0.3290	-0.3290	-0.3290	-0.3290	-0.3290
0.625	*****	*****	-0.3318	-0.3352	-0.3352	-0.3352	-0.3352	-0.3352	-0.3352	-0.3352
0.650	-0.4377	-0.3908	-0.3639	-0.3727	-0.3727	-0.3727	-0.3727	-0.3727	-0.3727	-0.3727
0.675	*****	-0.4297	-0.3750	-0.4694	-0.4694	-0.4694	-0.4694	-0.4694	-0.4694	-0.4694
0.700	-0.4869	-0.4435	-0.3822	-0.6318	-1.0014	-1.0014	-1.0014	-1.0014	-1.0014	-1.0014
0.725	*****	-0.4510	*****	-0.8320	-1.0127	-1.0127	-1.0127	-1.0127	-1.0127	-1.0127
0.750	-0.5289	-0.4571	*****	-0.9581	-0.9460	-0.9460	-0.9460	-0.9460	-0.9460	-0.9460
0.775	*****	-0.4602	-0.7267	-1.0251	-0.8499	-0.8499	-0.8499	-0.8499	-0.8499	-0.8499
0.800	-0.5709	-0.5011	-0.8534	-0.9876	*****	*****	*****	*****	*****	*****
0.825	*****	-0.7366	-0.9299	-0.9430	-0.6201	-0.6201	-0.6201	-0.6201	-0.6201	-0.6201
0.850	-0.6236	-0.9795	-0.9929	-0.8320	-0.5595	-0.5595	-0.5595	-0.5595	-0.5595	-0.5595
0.875	*****	-1.0739	-1.0413	-0.7438	-0.5310	-0.5310	-0.5310	-0.5310	-0.5310	-0.5310
0.900	-0.6830	-0.9743	-1.0204	-0.7228	-0.5336	-0.5336	-0.5336	-0.5336	-0.5336	-0.5336
0.925	*****	-1.0605	-0.9673	-0.7591	-0.5309	-0.5309	-0.5309	-0.5309	-0.5309	-0.5309
0.950	-0.9069	-1.3020	-0.9139	-0.8005	-0.4590	-0.4590	-0.4590	-0.4590	-0.4590	-0.4590
0.975	*****	-1.2881	-0.8741	-0.6775	-0.4102	-0.4102	-0.4102	-0.4102	-0.4102	-0.4102
1.000	-1.0111	-1.2776	-1.1232	-1.1738	-0.5903	-0.5903	-0.5903	-0.5903	-0.5903	-0.5903
-0.200	$C_{p,l}$	$C_{p,l}$	$C_{p,l}$	$C_{p,l}$	$C_{p,l}$	$C_{p,l}$	$C_{p,l}$	$C_{p,l}$	$C_{p,l}$	$C_{p,l}$
-0.400	0.2405	0.2314	0.2621	*****	*****	*****	*****	*****	*****	-0.5989
-0.600	0.2385	0.2408	0.2346	0.0679	-0.6619	-0.6619	-0.6619	-0.6619	-0.6619	-0.6619
-0.700	0.2571	0.2465	0.2314	0.1022	-0.6351	-0.6351	-0.6351	-0.6351	-0.6351	-0.6351
-0.800	0.2767	0.2484	0.2328	0.1190	-0.6085	-0.6085	-0.6085	-0.6085	-0.6085	-0.6085
-0.850	0.2985	*****	0.2408	0.1420	-0.5400	-0.5400	-0.5400	-0.5400	-0.5400	-0.5400
-0.900	*****	0.2836	0.2504	0.1569	-0.5392	-0.5392	-0.5392	-0.5392	-0.5392	-0.5392
-0.950	*****	0.2924	0.2643	0.1777	-0.5081	-0.5081	-0.5081	-0.5081	-0.5081	-0.5081
-0.975	0.2589	0.2619	0.2546	0.1944	-0.1716	-0.1716	-0.1716	-0.1716	-0.1716	-0.1716
-1.000	*****	0.1704	0.1878	0.1581	-0.0452	-0.0452	-0.0452	-0.0452	-0.0452	-0.0452
-1.000	-1.0525	-1.1955	-1.1704	-1.0983	-0.6380	-0.6380	-0.6380	-0.6380	-0.6380	-0.6380

Medium Radius L.E.
 Run No. = 27, Point No. = 542
 $C_N = 0.539$, $C_m = -0.1046$
 $\alpha = 11.3^\circ$, $M_\infty = 0.869$
 $R_{mac} = 59.8 \times 10^6$

Leading Edge Pressures



x/c_R	starb'd C_p	port C_p
0.10	-0.6199	*****
0.20	-1.0111	-1.0525
0.30	-1.2012	*****
0.40	-1.2776	-1.1955
0.50	-1.3371	*****
0.60	-1.1232	-1.1704
0.70	-0.8378	*****
0.80	-1.1738	-1.0983
0.90	*****	*****
0.95	-0.5903	-0.6380

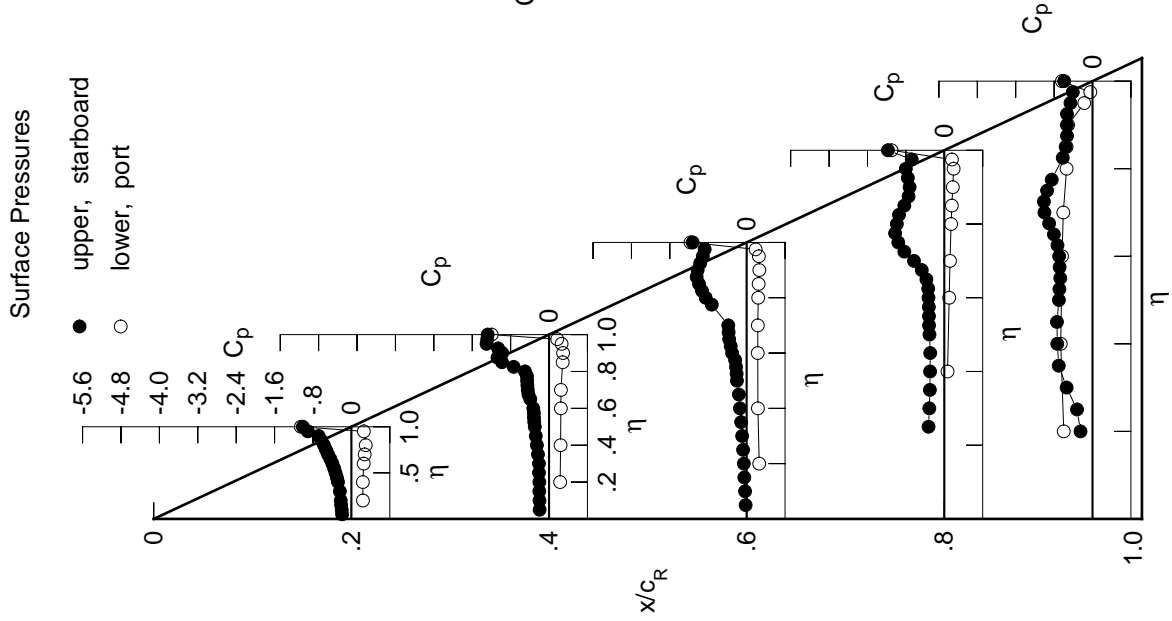
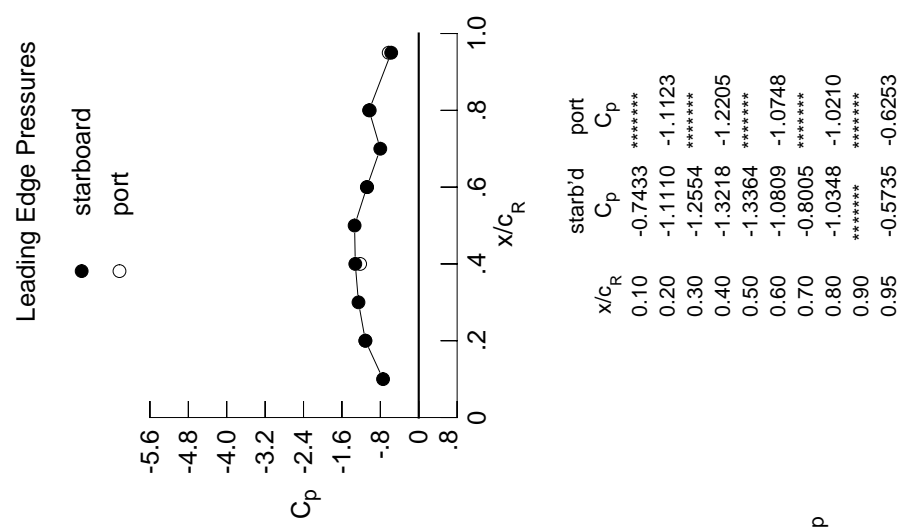

Table G3. Continued.

η	$x/c_R = .2$		$x/c_R = .4$		$x/c_R = .6$		$x/c_R = .8$		$x/c_R = .95$	
	$C_{p,u}$	$C_{p,u}$	$C_{p,u}$	$C_{p,u}$	$C_{p,u}$	$C_{p,u}$	$C_{p,u}$	$C_{p,u}$	$C_{p,u}$	$C_{p,u}$
0.050	-0.2110	-0.2316	-0.0438	*****	*****	*****	*****	*****	*****	*****
0.100	-0.2160	-0.2323	-0.0541	*****	*****	*****	*****	*****	*****	*****
0.150	-0.2343	-0.2360	-0.0721	*****	*****	*****	*****	*****	*****	*****
0.200	-0.2444	-0.2341	-0.0783	*****	*****	*****	*****	*****	*****	-0.2544
0.250	*****	-0.2385	-0.0997	-0.3546	-0.3201	*****	*****	*****	*****	*****
0.300	-0.2664	-0.2514	-0.1171	-0.3412	-0.4780	*****	*****	*****	*****	*****
0.350	*****	-0.2740	-0.1468	-0.3333	-0.5776	*****	*****	*****	*****	*****
0.400	-0.3108	-0.3006	-0.1696	-0.3359	-0.5739	*****	*****	*****	*****	*****
0.450	-0.3348	-0.3328	-0.1938	-0.3294	-0.5632	*****	*****	*****	*****	*****
0.500	-0.3608	-0.3418	-0.2406	-0.3199	-0.6053	*****	*****	*****	*****	*****
0.525	*****	-0.3418	-0.2400	-0.3193	-0.6369	*****	*****	*****	*****	*****
0.550	-0.3874	-0.3462	-0.2393	-0.3156	-0.6369	*****	*****	*****	*****	*****
0.575	*****	-0.3512	-0.2394	-0.3196	-0.6586	*****	*****	*****	*****	*****
0.600	-0.4271	-0.3651	-0.2792	-0.3426	-0.6936	*****	*****	*****	*****	*****
0.625	*****	*****	-0.2947	-0.3940	-0.7914	*****	*****	*****	*****	*****
0.650	-0.4735	-0.4366	-0.4052	-0.5255	-0.9450	*****	*****	*****	*****	*****
0.675	*****	-0.5136	-0.5902	-0.7402	-1.0960	*****	*****	*****	*****	*****
0.700	-0.5188	-0.5400	-0.7616	-0.9574	-1.2202	*****	*****	*****	*****	*****
0.725	*****	-0.5396	*****	-1.1153	-1.2754	*****	*****	*****	*****	*****
0.750	-0.5694	-0.5482	*****	-1.1522	-1.0430	*****	*****	*****	*****	*****
0.775	*****	-0.5188	-0.9845	-1.1077	-0.8196	*****	*****	*****	*****	*****
0.800	-0.6146	-0.5043	-0.9833	-1.0770	*****	*****	*****	*****	*****	*****
0.825	*****	-0.8157	-0.9998	-1.0352	-0.6153	*****	*****	*****	*****	*****
0.850	-0.6712	-1.2461	-1.0117	-0.8879	-0.5483	*****	*****	*****	*****	*****
0.875	*****	-1.3133	-1.0165	-0.8136	-0.5246	*****	*****	*****	*****	*****
0.900	-0.8369	-1.1990	-0.9788	-0.7850	-0.5278	*****	*****	*****	*****	*****
0.925	*****	-1.1813	-0.9251	-0.7540	-0.5405	*****	*****	*****	*****	*****
0.950	-1.2408	-1.2985	-0.8805	-0.7305	-0.4846	*****	*****	*****	*****	*****
0.975	*****	-1.2669	-0.8445	-0.6404	-0.4666	*****	*****	*****	*****	*****
1.000	-1.1110	-1.3218	-1.0809	-1.0348	-0.5735	*****	*****	*****	*****	*****
	$C_{p,l}$	$C_{p,l}$	$C_{p,l}$	$C_{p,l}$	$C_{p,l}$	$C_{p,l}$	$C_{p,l}$	$C_{p,l}$	$C_{p,l}$	$C_{p,l}$
-0.200	0.2709	0.2568	0.2805	*****	*****	*****	*****	*****	*****	-0.5853
-0.400	0.2697	0.2661	0.2538	0.0840	-0.6503	*****	*****	*****	*****	*****
-0.600	0.2888	0.2726	0.2511	0.1176	-0.6255	*****	*****	*****	*****	*****
-0.700	0.3069	0.2747	0.2526	0.1347	-0.5977	*****	*****	*****	*****	*****
-0.800	0.3245	*****	0.2608	0.1584	-0.5289	*****	*****	*****	*****	*****
-0.850	*****	0.3064	0.2689	0.1715	-0.5267	*****	*****	*****	*****	*****
-0.900	*****	0.3098	0.2790	0.1905	-0.4923	*****	*****	*****	*****	*****
-0.950	0.2572	0.2658	0.2579	0.1981	-0.1660	*****	*****	*****	*****	*****
-0.975	*****	0.1578	0.1782	0.1494	-0.0496	*****	*****	*****	*****	*****
-1.000	-1.1123	-1.2205	-1.0748	-1.0210	-0.6253	*****	*****	*****	*****	*****

Medium Radius L.E.
 Run No. = 27, Point No. = 543
 $C_N = 0.609$, $C_m = -0.1185$
 $\alpha = 12.4^\circ$, $M_\infty = 0.868$
 $R_{mac} = 59.8 \times 10^6$



x/c_R	starb'd C_p	port C_p
0.10	-0.7433	*****
0.20	-1.1110	-1.1123
0.30	-1.2554	*****
0.40	-1.3218	-1.2205
0.50	-1.3364	*****
0.60	-1.0809	-1.0748
0.70	-0.8005	*****
0.80	-1.0348	-1.0210
0.90	*****	*****
0.95	-0.5735	-0.6253

Table G3. Continued.

η	$x/c_R = .2$		$x/c_R = .4$		$x/c_R = .6$		$x/c_R = .8$		$x/c_R = .95$	
	$C_{p,u}$	$C_{p,u}$	$C_{p,u}$	$C_{p,u}$	$C_{p,u}$	$C_{p,u}$	$C_{p,u}$	$C_{p,u}$	$C_{p,u}$	$C_{p,u}$
0.050	-0.2341	-0.2839	-0.0628	*****	*****	*****	*****	*****	*****	*****
0.100	-0.2355	-0.2847	-0.0721	*****	*****	*****	*****	*****	*****	*****
0.150	-0.2555	-0.2865	-0.0862	*****	*****	*****	*****	*****	*****	*****
0.200	-0.2704	-0.2820	-0.0975	*****	*****	*****	*****	*****	*****	*****
0.250	*****	-0.2921	-0.1162	-0.3811	-0.2557	*****	*****	*****	*****	*****
0.300	-0.3033	-0.3092	-0.1378	-0.3677	-0.3409	*****	*****	*****	*****	*****
0.350	*****	-0.3362	-0.1669	-0.3572	-0.3881	*****	*****	*****	*****	*****
0.400	-0.3477	-0.3534	-0.1814	-0.3408	-0.4633	*****	*****	*****	*****	*****
0.450	-0.3663	-0.3990	-0.1703	-0.3283	-0.5666	*****	*****	*****	*****	*****
0.500	-0.3914	-0.4128	-0.1892	-0.3127	-0.5921	*****	*****	*****	*****	*****
0.525	*****	-0.4074	-0.2008	-0.3139	-0.5967	*****	*****	*****	*****	*****
0.550	-0.4192	-0.4101	-0.2434	-0.3259	-0.6065	*****	*****	*****	*****	*****
0.575	*****	-0.4156	-0.3328	-0.3729	-0.6758	*****	*****	*****	*****	*****
0.600	-0.4600	-0.4258	-0.5453	-0.4766	-0.7822	*****	*****	*****	*****	*****
0.625	*****	*****	-0.7085	-0.6433	-0.9393	*****	*****	*****	*****	*****
0.650	-0.5037	-0.5338	-0.8649	-0.8649	-1.1055	*****	*****	*****	*****	*****
0.675	*****	-0.6850	-0.9689	-1.0768	-1.2332	*****	*****	*****	*****	*****
0.700	-0.5503	-0.8219	-1.0106	-1.2244	-1.3106	*****	*****	*****	*****	*****
0.725	*****	-0.8631	*****	-1.3026	-1.0325	*****	*****	*****	*****	*****
0.750	-0.5853	-0.8667	*****	-1.2403	-0.9013	*****	*****	*****	*****	*****
0.775	*****	-0.9711	-1.0113	-1.1145	-0.7660	*****	*****	*****	*****	*****
0.800	-0.6644	-0.9979	-1.0152	-1.0348	*****	*****	*****	*****	*****	*****
0.825	*****	-1.1179	-1.0352	-0.9553	-0.6013	*****	*****	*****	*****	*****
0.850	-0.9843	-1.1983	-1.0362	-0.8575	-0.5481	*****	*****	*****	*****	*****
0.875	*****	-1.1634	-1.0104	-0.8211	-0.5267	*****	*****	*****	*****	*****
0.900	-1.1969	-1.0517	-0.9530	-0.8033	-0.5384	*****	*****	*****	*****	*****
0.925	*****	-1.0092	-0.9013	-0.7534	-0.5482	*****	*****	*****	*****	*****
0.950	-1.2870	-1.2095	-0.8652	-0.7230	-0.5029	*****	*****	*****	*****	*****
0.975	*****	-1.1927	-0.8322	-0.6382	-0.4851	*****	*****	*****	*****	*****
1.000	-1.1758	-1.3093	-1.0187	-0.9684	-0.5397	*****	*****	*****	*****	*****
-0.200	$C_{p,l}$	$C_{p,l}$	$C_{p,l}$	$C_{p,l}$	$C_{p,l}$	$C_{p,l}$	$C_{p,l}$	$C_{p,l}$	$C_{p,l}$	$C_{p,l}$
-0.400	0.3012	0.2823	0.2998	*****	*****	*****	*****	*****	*****	*****
-0.600	0.3004	0.2919	0.2730	0.1012	-0.6370	*****	*****	*****	*****	*****
-0.700	0.3198	0.2978	0.2717	0.1346	-0.6124	*****	*****	*****	*****	*****
-0.800	0.3362	0.3000	0.2718	0.1507	-0.5845	*****	*****	*****	*****	*****
-0.850	0.3496	*****	0.2795	0.1744	-0.5154	*****	*****	*****	*****	*****
-0.900	*****	0.3269	0.2867	0.1862	-0.5146	*****	*****	*****	*****	*****
-0.950	*****	0.3248	0.2918	0.2026	-0.4769	*****	*****	*****	*****	*****
-0.975	0.2570	0.2684	0.2593	0.2009	-0.1636	*****	*****	*****	*****	*****
-1.000	*****	0.1466	0.1662	0.1394	-0.0591	*****	*****	*****	*****	*****
-1.000	-1.1487	-1.2105	-0.9893	-0.9596	-0.5971	*****	*****	*****	*****	*****

Medium Radius L.E.
 Run No. = 27 , Point No. = 544
 $C_N = 0.677$, $C_m = -0.1327$
 $\alpha = 13.4^\circ$, $M_\infty = 0.871$
 $R_{mac} = 59.9 \times 10^6$

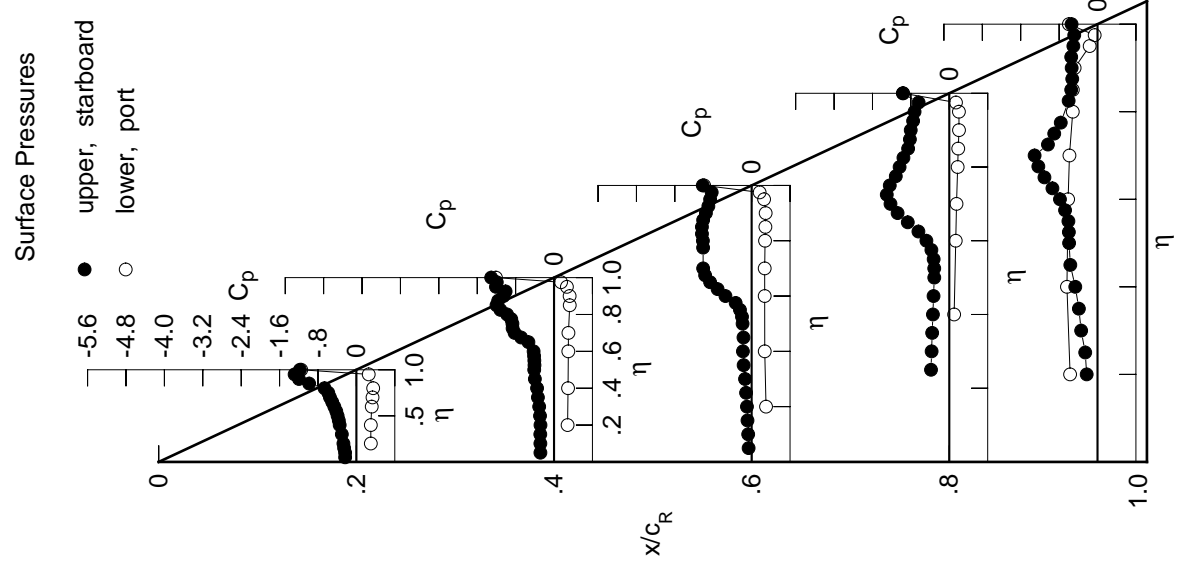
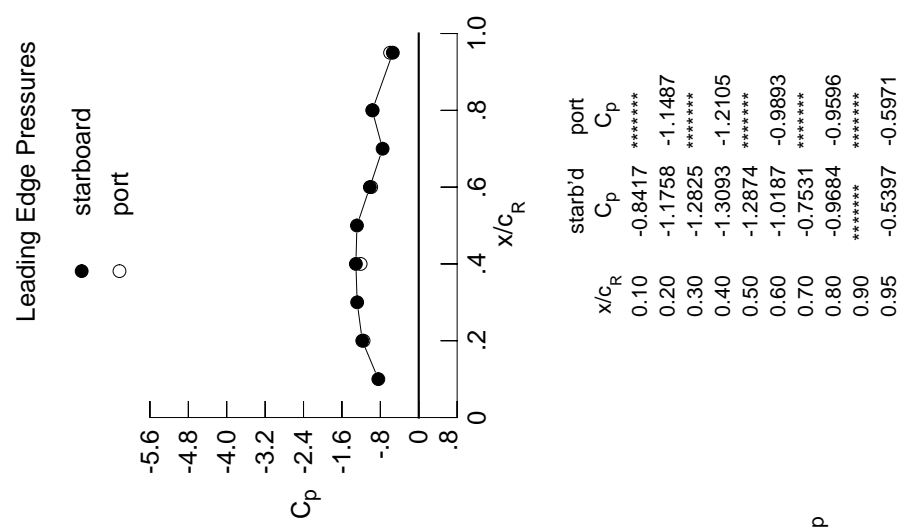

x/c_R	starb'd C_p	port C_p
0.10	-0.8417	*****
0.20	-1.1758	-1.1487
0.30	-1.2825	*****
0.40	-1.3093	-1.2105
0.50	-1.2874	*****
0.60	-1.0187	-0.9893
0.70	-0.7531	*****
0.80	-0.9684	-0.9596
0.90	*****	*****
0.95	-0.5397	-0.5971

Table G3. Continued.

η	$x/c_R = .2$		$x/c_R = .4$		$x/c_R = .6$		$x/c_R = .8$		$x/c_R = .95$	
	$C_{p,u}$	$C_{p,u}$	$C_{p,u}$	$C_{p,u}$	$C_{p,u}$	$C_{p,u}$	$C_{p,u}$	$C_{p,u}$	$C_{p,u}$	$C_{p,u}$
0.050	-0.2543	-0.3129	-0.0829	*****	*****	*****	*****	*****	*****	*****
0.100	-0.2537	-0.3140	-0.0949	*****	*****	*****	*****	*****	*****	*****
0.150	-0.2696	-0.3129	-0.1052	*****	*****	*****	*****	*****	*****	*****
0.200	-0.2854	-0.3052	-0.1179	*****	*****	*****	*****	*****	*****	-0.2570
0.250	*****	-0.3194	-0.1417	-0.3969	-0.3969	-0.3969	-0.3969	-0.3969	-0.3969	-0.2694
0.300	-0.3461	-0.3377	-0.1559	-0.3812	-0.3812	-0.3812	-0.3812	-0.3812	-0.3812	-0.3219
0.350	*****	-0.3545	-0.1646	-0.3627	-0.3627	-0.3627	-0.3627	-0.3627	-0.3627	-0.3895
0.400	-0.3772	-0.3509	-0.1754	-0.3446	-0.3446	-0.3446	-0.3446	-0.3446	-0.3446	-0.4852
0.450	-0.3892	-0.3667	-0.1721	-0.3364	-0.3364	-0.3364	-0.3364	-0.3364	-0.3364	-0.5361
0.500	-0.4082	-0.4318	-0.2272	-0.3392	-0.3392	-0.3392	-0.3392	-0.3392	-0.3392	-0.5619
0.525	*****	-0.4804	-0.2675	-0.3578	-0.3578	-0.3578	-0.3578	-0.3578	-0.3578	-0.5992
0.550	-0.4361	-0.5087	-0.3479	-0.4003	-0.4003	-0.4003	-0.4003	-0.4003	-0.4003	-0.6551
0.575	*****	-0.5294	-0.4881	-0.4945	-0.4945	-0.4945	-0.4945	-0.4945	-0.4945	-0.7631
0.600	-0.4733	-0.5727	-0.7390	-0.6464	-0.6464	-0.6464	-0.6464	-0.6464	-0.6464	-0.8917
0.625	*****	*****	-0.9229	-0.8419	-0.8419	-0.8419	-0.8419	-0.8419	-0.8419	-1.0417
0.650	-0.5342	-0.7867	-1.0961	-1.0523	-1.0523	-1.0523	-1.0523	-1.0523	-1.0523	-1.1865
0.675	*****	-0.9436	-1.2098	-1.2326	-1.2326	-1.2326	-1.2326	-1.2326	-1.2326	-1.1504
0.700	-0.5912	-1.0662	-1.2437	-1.3571	-1.3571	-1.3571	-1.3571	-1.3571	-1.3571	-0.8818
0.725	*****	-1.1285	*****	-1.4352	-0.8535	-0.8535	-0.8535	-0.8535	-0.8535	-0.8535
0.750	-0.6849	-1.1647	*****	-1.3455	-0.7826	-0.7826	-0.7826	-0.7826	-0.7826	-0.7826
0.775	*****	-1.1706	-1.0687	-1.1277	-0.9745	-0.9745	-0.9745	-0.9745	-0.9745	-0.7017
0.800	-1.0111	-1.1466	-1.0797	-0.9745	*****	*****	*****	*****	*****	*****
0.825	*****	-1.1225	-1.0920	-0.8664	-0.6170	-0.6170	-0.6170	-0.6170	-0.6170	-0.6170
0.850	-1.2531	-1.1161	-1.0664	-0.8271	-0.5548	-0.5548	-0.5548	-0.5548	-0.5548	-0.5548
0.875	*****	-1.1104	-0.9969	-0.8134	-0.5622	-0.5622	-0.5622	-0.5622	-0.5622	-0.5622
0.900	-1.2887	-1.0467	-0.9197	-0.8124	-0.5445	-0.5445	-0.5445	-0.5445	-0.5445	-0.5445
0.925	*****	-1.0093	-0.8724	-0.7353	-0.5332	-0.5332	-0.5332	-0.5332	-0.5332	-0.5332
0.950	-1.2785	-1.1401	-0.8355	-0.7523	-0.4681	-0.4681	-0.4681	-0.4681	-0.4681	-0.4681
0.975	*****	-1.0778	-0.8071	-0.6720	-0.4107	-0.4107	-0.4107	-0.4107	-0.4107	-0.4107
1.000	-1.2384	-1.2322	-0.9621	-0.9596	-0.4818	-0.4818	-0.4818	-0.4818	-0.4818	-0.4818
-0.200	0.3332	0.3082	0.3190	*****	-0.5606	-0.5606	-0.5606	-0.5606	-0.5606	-0.5606
-0.400	0.3321	0.3182	0.2928	0.1172	-0.6271	-0.6271	-0.6271	-0.6271	-0.6271	-0.6271
-0.600	0.3515	0.3240	0.2908	0.1508	-0.6023	-0.6023	-0.6023	-0.6023	-0.6023	-0.6023
-0.700	0.3654	0.3262	0.2931	0.1673	-0.5742	-0.5742	-0.5742	-0.5742	-0.5742	-0.5742
-0.800	0.3744	*****	0.2985	0.1892	-0.5037	-0.5037	-0.5037	-0.5037	-0.5037	-0.5037
-0.850	*****	0.3479	0.3038	0.2012	-0.5011	-0.5011	-0.5011	-0.5011	-0.5011	-0.5011
-0.900	*****	0.3390	0.3051	0.2146	-0.4592	-0.4592	-0.4592	-0.4592	-0.4592	-0.4592
-0.950	0.2549	0.2699	0.2594	0.2024	-0.1546	-0.1546	-0.1546	-0.1546	-0.1546	-0.1546
-0.975	*****	0.1336	0.1537	0.1278	-0.0591	-0.0591	-0.0591	-0.0591	-0.0591	-0.0591
-1.000	-1.1896	-1.1656	-0.9281	-0.9247	-0.5527	-0.5527	-0.5527	-0.5527	-0.5527	-0.5527

Medium Radius L.E.
 Run No. = 27 , Point No. = 545
 $C_N = 0.737$, $C_m = -0.1413$
 $\alpha = 14.5^\circ$, $M_\infty = 0.869$
 $R_{mac} = 59.8 \times 10^6$

Leading Edge Pressures

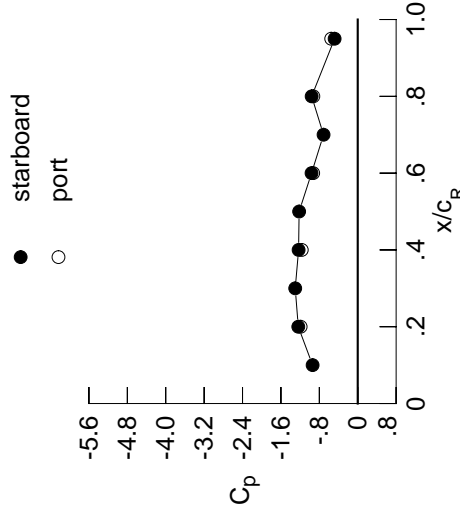

x/c_R	starb'd C_p	port C_p
0.10	-0.9403	*****
0.20	-1.2384	-1.1896
0.30	-1.3021	*****
0.40	-1.2322	-1.1656
0.50	-1.2211	*****
0.60	-0.9621	-0.9281
0.70	-0.7122	*****
0.80	-0.9596	-0.9247
0.90	*****	*****
0.95	-0.4818	-0.5527

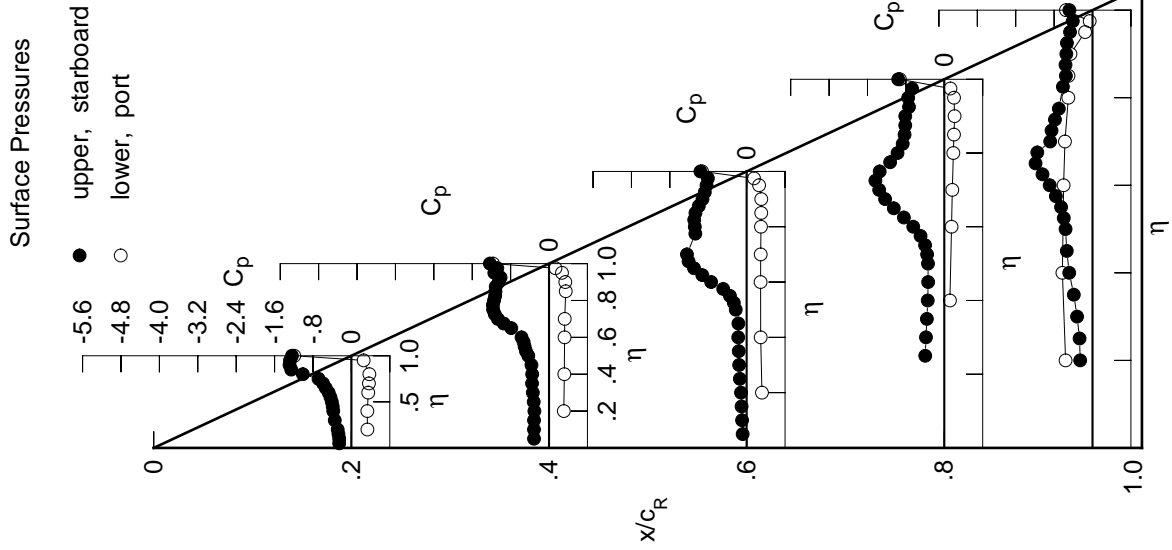

Table G3. Continued.

η	$x/c_R = .2$		$x/c_R = .4$		$x/c_R = .6$		$x/c_R = .8$		$x/c_R = .95$	
	$C_{p,u}$	$C_{p,u}$	$C_{p,u}$	$C_{p,u}$	$C_{p,u}$	$C_{p,u}$	$C_{p,u}$	$C_{p,u}$	$C_{p,u}$	$C_{p,u}$
0.050	-0.3069	-0.3718	-0.1186	*****	*****	*****	*****	*****	*****	*****
0.100	-0.2997	-0.3731	-0.1312	*****	*****	*****	*****	*****	*****	*****
0.150	-0.3110	-0.3667	-0.1454	*****	*****	*****	*****	*****	*****	*****
0.200	-0.3255	-0.3675	-0.1710	*****	*****	*****	*****	*****	*****	-0.4764
0.250	*****	-0.3926	-0.2041	-0.4511	-0.4618	*****	*****	*****	*****	-0.4618
0.300	-0.4106	-0.3988	-0.2253	-0.4382	-0.4885	*****	*****	*****	*****	-0.4885
0.350	*****	-0.3978	-0.2369	-0.4247	-0.4995	*****	*****	*****	*****	-0.4995
0.400	-0.4297	-0.3911	-0.2619	-0.4121	-0.5603	*****	*****	*****	*****	-0.5603
0.450	-0.4393	-0.4001	-0.2842	-0.4249	-0.5910	*****	*****	*****	*****	-0.5910
0.500	-0.4635	-0.4472	-0.4333	-0.4910	-0.6499	*****	*****	*****	*****	-0.6499
0.525	*****	-0.5453	-0.5629	-0.5651	-0.7137	*****	*****	*****	*****	-0.7137
0.550	-0.4787	-0.6974	-0.7433	-0.6755	-0.7992	*****	*****	*****	*****	-0.7992
0.575	*****	-0.8975	-0.9325	-0.8265	-0.9230	*****	*****	*****	*****	-0.9230
0.600	-0.4917	-1.0951	-1.1461	-0.9922	-1.0508	*****	*****	*****	*****	-1.0508
0.625	*****	*****	-1.2782	-1.1459	-1.1264	*****	*****	*****	*****	-1.1264
0.650	-0.6873	-1.2985	-1.3852	-1.2844	-0.7408	*****	*****	*****	*****	-0.7408
0.675	*****	-1.2922	-1.4604	-1.3974	-0.6768	*****	*****	*****	*****	-0.6768
0.700	-1.0849	-1.3170	-1.4825	-1.3820	-0.6288	*****	*****	*****	*****	-0.6288
0.725	*****	-1.3641	*****	-1.1695	-0.5956	*****	*****	*****	*****	-0.5956
0.750	-1.0546	-1.3527	*****	-1.1532	-0.5858	*****	*****	*****	*****	-0.5858
0.775	*****	-1.2759	-1.2068	-1.2029	-0.5477	*****	*****	*****	*****	-0.5477
0.800	-1.1115	-1.2004	-1.1657	-1.2194	*****	*****	*****	*****	*****	*****
0.825	*****	-1.1510	-1.0900	-1.1202	-0.5273	*****	*****	*****	*****	-0.5273
0.850	-1.3808	-1.1306	-1.0387	-1.0162	-0.5077	*****	*****	*****	*****	-0.5077
0.875	*****	-1.1303	-1.0207	-0.9406	-0.5399	*****	*****	*****	*****	-0.5399
0.900	-1.3685	-1.1008	-1.0029	-0.8515	-0.5771	*****	*****	*****	*****	-0.5771
0.925	*****	-1.0808	-0.9431	-0.7702	-0.5962	*****	*****	*****	*****	-0.5962
0.950	-1.3109	-1.1181	-0.9051	-0.8239	-0.5128	*****	*****	*****	*****	-0.5128
0.975	*****	-1.0148	-0.8936	-0.7521	-0.4393	*****	*****	*****	*****	-0.4393
1.000	-1.3398	-1.1589	-1.0013	-0.9355	-0.4523	*****	*****	*****	*****	-0.4523
-0.200	$C_{p,l}$	$C_{p,l}$	$C_{p,l}$	$C_{p,l}$	$C_{p,l}$	$C_{p,l}$	$C_{p,l}$	$C_{p,l}$	$C_{p,l}$	$C_{p,l}$
-0.400	0.3929	0.3577	0.3551	*****	*****	*****	*****	*****	*****	-0.5361
-0.600	0.3921	0.3671	0.3296	0.1493	0.6060	*****	*****	*****	*****	-0.6060
-0.700	0.4094	0.3713	0.3274	0.1813	0.5830	*****	*****	*****	*****	-0.5830
-0.800	0.4186	0.3729	0.3285	0.1966	0.5539	*****	*****	*****	*****	-0.5539
-0.850	0.4178	*****	0.3308	0.2173	-0.4801	*****	*****	*****	*****	-0.4801
-0.900	*****	0.3819	0.3321	0.2273	-0.4744	*****	*****	*****	*****	-0.4744
-0.950	*****	0.3599	0.3221	0.2344	-0.4270	*****	*****	*****	*****	-0.4270
-0.975	0.2481	0.2664	0.2512	0.2024	-0.1403	*****	*****	*****	*****	-0.1403
-1.000	*****	0.1029	0.1179	0.1028	-0.0653	*****	*****	*****	*****	-0.0653
-1.000	-1.2610	-1.1040	-0.9689	-0.8956	-0.5269	*****	*****	*****	*****	-0.5269

Medium Radius L.E.
 Run No. = 27 , Point No. = 546
 $C_N = 0.850$, $C_m = -0.1548$
 $\alpha = 16.5^\circ$, $M_\infty = 0.868$
 $R_{mac} = 59.7 \times 10^6$

Leading Edge Pressures

● starboard
 ○ port

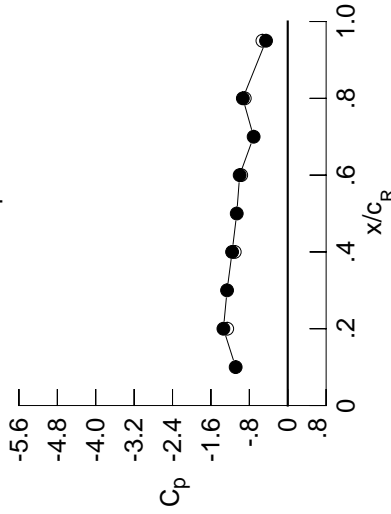

x/c_R	starb'd C_p	port C_p
0.10	-1.0847	*****
0.20	-1.3398	-1.2610
0.30	-1.2636	*****
0.40	-1.1589	-1.1040
0.50	-1.0621	*****
0.60	-1.0013	-0.9689
0.70	-0.7106	*****
0.80	-0.9355	-0.8956
0.90	*****	*****
0.95	-0.4523	-0.5269

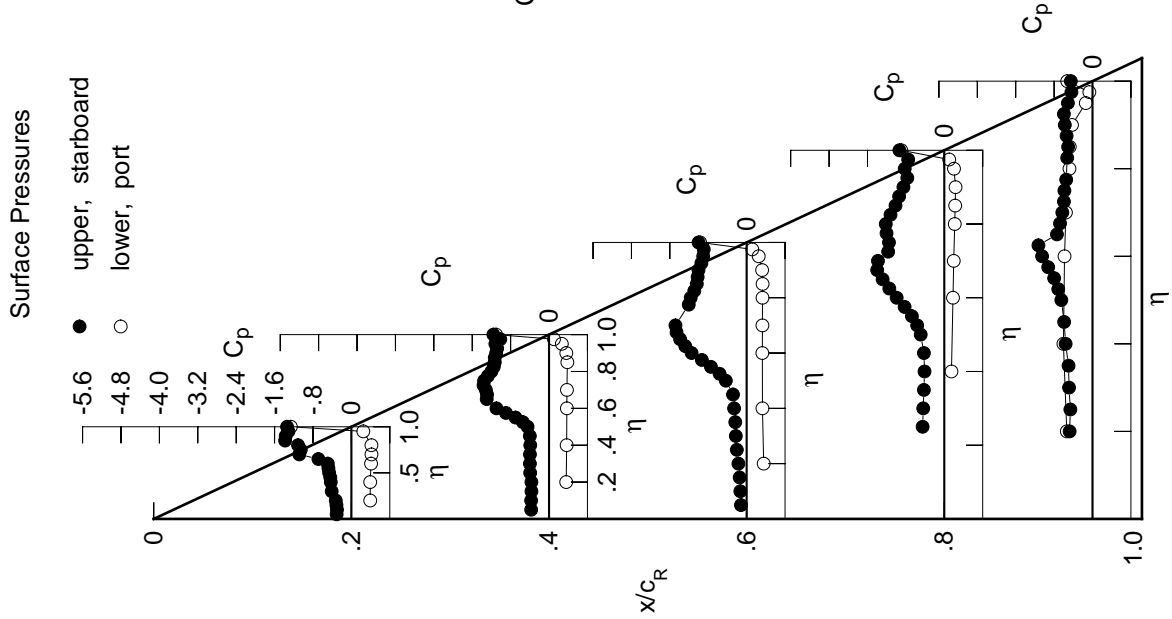
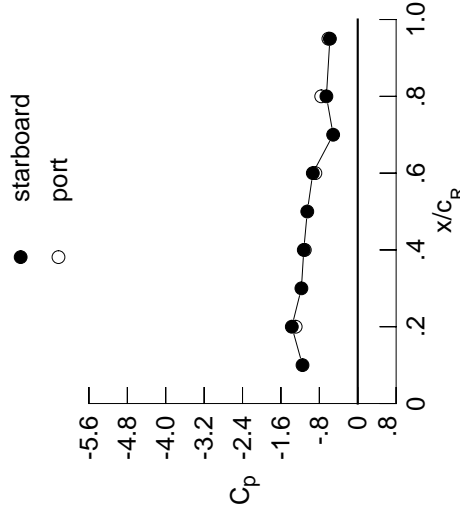

Table G3. Continued.

η	$x/c_R = .2$		$x/c_R = .4$		$x/c_R = .6$		$x/c_R = .8$		$x/c_R = .95$	
	$C_{p,u}$	$C_{p,u}$	$C_{p,u}$	$C_{p,u}$	$C_{p,u}$	$C_{p,u}$	$C_{p,u}$	$C_{p,u}$	$C_{p,u}$	$C_{p,u}$
0.050	-0.3585	-0.4283	-0.0443	*****	*****	*****	*****	*****	*****	*****
0.100	-0.3506	-0.4271	-0.0575	*****	*****	*****	*****	*****	*****	*****
0.150	-0.3567	-0.4250	-0.0735	*****	*****	*****	*****	*****	*****	*****
0.200	-0.4017	-0.4376	-0.0997	*****	*****	*****	*****	*****	*****	-0.7376
0.250	*****	-0.4420	-0.1144	-0.1634	-0.1634	-0.1634	-0.1634	-0.1634	-0.1634	-0.7178
0.300	-0.4059	-0.4394	-0.1310	-0.1373	-0.1373	-0.1373	-0.1373	-0.1373	-0.1373	-0.7028
0.350	*****	-0.4468	-0.1600	-0.1291	-0.1291	-0.1291	-0.1291	-0.1291	-0.1291	-0.7104
0.400	-0.4193	-0.4586	-0.2125	-0.1064	-0.1064	-0.1064	-0.1064	-0.1064	-0.1064	-0.7260
0.450	-0.4819	-0.5161	-0.2880	-0.1444	-0.1444	-0.1444	-0.1444	-0.1444	-0.1444	-0.7416
0.500	-0.6258	-0.6684	-0.5534	-0.2508	-0.2508	-0.2508	-0.2508	-0.2508	-0.2508	-0.7251
0.525	*****	-0.8318	-0.7303	-0.3466	-0.3466	-0.3466	-0.3466	-0.3466	-0.3466	-0.7364
0.550	-0.7658	-1.0348	-0.9073	-0.4652	-0.4652	-0.4652	-0.4652	-0.4652	-0.4652	-0.7058
0.575	*****	-1.2170	-1.0728	-0.6064	-0.6064	-0.6064	-0.6064	-0.6064	-0.6064	-0.7157
0.600	-1.0176	-1.3669	-1.2411	-0.7410	-0.7410	-0.7410	-0.7410	-0.7410	-0.7410	-0.7006
0.625	*****	*****	-1.3264	-0.8009	-0.8009	-0.8009	-0.8009	-0.8009	-0.8009	-0.6963
0.650	-1.2194	-1.5525	-1.4140	-0.7277	-0.6943	-0.6943	-0.6943	-0.6943	-0.6943	-0.6943
0.675	*****	-1.5722	-1.4503	-0.6028	-0.6725	-0.6725	-0.6725	-0.6725	-0.6725	-0.6725
0.700	-1.2377	-1.5329	-1.2816	-0.5586	-0.6596	-0.6596	-0.6596	-0.6596	-0.6596	-0.6596
0.725	*****	-1.4388	*****	-0.5201	-0.6609	-0.6609	-0.6609	-0.6609	-0.6609	-0.6609
0.750	-1.2391	-1.4169	*****	-0.4891	-0.6525	-0.6525	-0.6525	-0.6525	-0.6525	-0.6525
0.775	*****	-1.3494	-1.1701	-0.4800	-0.6414	-0.6414	-0.6414	-0.6414	-0.6414	-0.6414
0.800	-1.3321	-1.2501	-1.1544	-0.4878	*****	*****	*****	*****	*****	*****
0.825	*****	-1.1898	-1.1436	-0.4897	-0.6273	-0.6273	-0.6273	-0.6273	-0.6273	-0.6273
0.850	-1.3645	-1.1464	-1.0987	-0.5214	-0.6075	-0.6075	-0.6075	-0.6075	-0.6075	-0.6075
0.875	*****	-1.1191	-1.0261	-0.5174	-0.5980	-0.5980	-0.5980	-0.5980	-0.5980	-0.5980
0.900	-1.2725	-1.0992	-0.9374	-0.5095	-0.5847	-0.5847	-0.5847	-0.5847	-0.5847	-0.5847
0.925	*****	-1.0826	-0.8895	-0.5148	-0.5786	-0.5786	-0.5786	-0.5786	-0.5786	-0.5786
0.950	-1.2714	-1.0948	-0.8667	-0.5600	-0.5201	-0.5201	-0.5201	-0.5201	-0.5201	-0.5201
0.975	*****	-1.0214	-0.8470	-0.5275	-0.4913	-0.4913	-0.4913	-0.4913	-0.4913	-0.4913
1.000	-1.3735	-1.1241	-0.9358	-0.6526	-0.5802	-0.5802	-0.5802	-0.5802	-0.5802	-0.5802
-0.200	$C_{p,l}$	$C_{p,l}$	$C_{p,l}$	$C_{p,l}$	$C_{p,l}$	$C_{p,l}$	$C_{p,l}$	$C_{p,l}$	$C_{p,l}$	$C_{p,l}$
-0.400	0.4523	0.4070	0.3917	*****	-0.5466	-0.5466	-0.5466	-0.5466	-0.5466	-0.5466
-0.600	0.4492	0.4160	0.3678	0.1736	0.1736	0.1736	0.1736	0.1736	0.1736	0.1736
-0.700	0.4637	0.4190	0.3658	0.2065	-0.5772	-0.5772	-0.5772	-0.5772	-0.5772	-0.5772
-0.800	0.4682	0.4155	0.3673	0.2235	-0.5479	-0.5479	-0.5479	-0.5479	-0.5479	-0.5479
-0.850	0.4571	*****	0.3651	0.2440	-0.4781	-0.4781	-0.4781	-0.4781	-0.4781	-0.4781
-0.900	*****	0.4128	0.3636	0.2500	-0.4783	-0.4783	-0.4783	-0.4783	-0.4783	-0.4783
-0.950	*****	0.3787	0.3458	0.2558	-0.4355	-0.4355	-0.4355	-0.4355	-0.4355	-0.4355
-0.975	0.2442	0.2631	0.2565	0.2202	-0.1654	-0.1654	-0.1654	-0.1654	-0.1654	-0.1654
-1.000	*****	0.0772	0.1052	0.1228	-0.1050	-0.1050	-0.1050	-0.1050	-0.1050	-0.1050
-1.000	-1.2928	-1.1024	-0.8822	-0.7609	-0.6112	-0.6112	-0.6112	-0.6112	-0.6112	-0.6112

Medium Radius L.E.
 Run No. = 27 , Point No. = 547
 $C_N = 0.809$, $C_m = -0.1133$
 $\alpha = 18.5^\circ$, $M_\infty = 0.871$
 $R_{mac} = 59.8 \times 10^6$

Leading Edge Pressures



x/c_R	starb'd C_p	port C_p
0.10	-1.1507	*****
0.20	-1.3735	-1.2928
0.30	-1.1734	*****
0.40	-1.1241	-1.1024
0.50	-1.0509	*****
0.60	-0.9358	-0.8822
0.70	-0.5116	*****
0.80	-0.6526	-0.7609
0.90	*****	*****
0.95	-0.5802	-0.6112

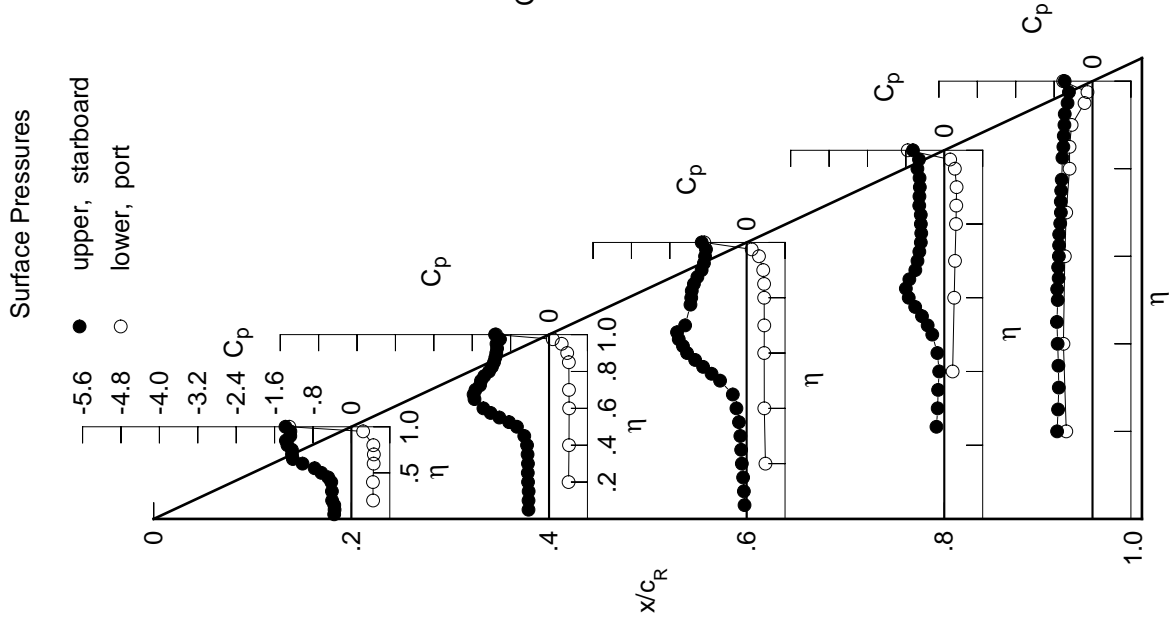

Table G3. Continued.

η	$x/c_R = .2$		$x/c_R = .4$		$x/c_R = .6$		$x/c_R = .8$		$x/c_R = .95$	
	$C_{p,u}$	$C_{p,u}$	$C_{p,u}$	$C_{p,u}$	$C_{p,u}$	$C_{p,u}$	$C_{p,u}$	$C_{p,u}$	$C_{p,u}$	$C_{p,u}$
0.050	-0.4244	-0.5047	-0.0193	*****	*****	*****	*****	*****	*****	*****
0.100	-0.4162	-0.5008	-0.0310	*****	*****	*****	*****	*****	*****	*****
0.150	-0.4531	-0.5012	-0.0460	*****	*****	*****	*****	*****	*****	*****
0.200	-0.4591	-0.5159	-0.0655	*****	*****	*****	*****	*****	*****	-0.6019
0.250	*****	-0.5207	-0.0995	-0.3580	-0.5612	*****	*****	*****	*****	*****
0.300	-0.4587	-0.5275	-0.1205	-0.3659	-0.5570	*****	*****	*****	*****	*****
0.350	*****	-0.5519	-0.1739	-0.4197	-0.5888	*****	*****	*****	*****	*****
0.400	-0.4804	-0.6110	-0.2753	-0.4668	-0.6402	*****	*****	*****	*****	*****
0.450	-0.5052	-0.7614	-0.4262	-0.5826	-0.7097	*****	*****	*****	*****	*****
0.500	-0.6311	-0.9917	-0.7318	-0.7259	-0.7323	*****	*****	*****	*****	*****
0.525	*****	-1.1304	-0.8954	-0.7913	-0.7608	*****	*****	*****	*****	*****
0.550	-1.0728	-1.2752	-1.0451	-0.8392	-0.7393	*****	*****	*****	*****	*****
0.575	*****	-1.3822	-1.1803	-0.8667	-0.7485	*****	*****	*****	*****	*****
0.600	-1.4833	-1.4743	-1.3165	-0.8624	-0.7292	*****	*****	*****	*****	*****
0.625	*****	*****	-1.3875	-0.8324	-0.7258	*****	*****	*****	*****	*****
0.650	-1.6377	-1.6197	-1.2733	-0.8292	-0.7227	*****	*****	*****	*****	*****
0.675	*****	-1.6467	-1.1436	-0.8076	-0.7091	*****	*****	*****	*****	*****
0.700	-1.4407	-1.5394	-1.1023	-0.7537	-0.6997	*****	*****	*****	*****	*****
0.725	*****	-1.4856	*****	-0.7167	-0.6971	*****	*****	*****	*****	*****
0.750	-1.3617	-1.4474	*****	-0.6800	-0.6872	*****	*****	*****	*****	*****
0.775	*****	-1.3975	-1.0918	-0.6693	-0.6768	*****	*****	*****	*****	*****
0.800	-1.4244	-1.3253	-1.1616	-0.6700	*****	*****	*****	*****	*****	*****
0.825	*****	-1.2769	-1.2164	-0.6656	-0.6514	*****	*****	*****	*****	*****
0.850	-1.4034	-1.2435	-1.0753	-0.6929	-0.6265	*****	*****	*****	*****	*****
0.875	*****	-1.1916	-0.9080	-0.7071	-0.6025	*****	*****	*****	*****	*****
0.900	-1.2587	-1.1454	-0.8381	-0.7283	-0.5660	*****	*****	*****	*****	*****
0.925	*****	-1.1247	-0.8416	-0.7632	-0.5330	*****	*****	*****	*****	*****
0.950	-1.2311	-1.1440	-0.8362	-0.8108	-0.4761	*****	*****	*****	*****	*****
0.975	*****	-1.1054	-0.8002	-0.7814	-0.4365	*****	*****	*****	*****	*****
1.000	-1.4010	-1.1760	-0.8347	-0.8728	-0.4446	*****	*****	*****	*****	*****
-0.200	$C_{p,l}$	$C_{p,l}$	$C_{p,l}$	$C_{p,l}$	$C_{p,l}$	$C_{p,l}$	$C_{p,l}$	$C_{p,l}$	$C_{p,l}$	$C_{p,l}$
-0.400	0.5090	0.4532	0.4273	*****	*****	*****	*****	*****	*****	-0.5258
-0.600	0.5064	0.4625	0.4034	0.2042	-0.5879	*****	*****	*****	*****	*****
-0.700	0.5173	0.4629	0.4009	0.2350	-0.5602	*****	*****	*****	*****	*****
-0.800	0.5156	0.4581	0.4008	0.2503	-0.5279	*****	*****	*****	*****	*****
-0.850	0.4933	*****	0.3949	0.2669	-0.4544	*****	*****	*****	*****	*****
-0.900	*****	0.4394	0.3878	0.2697	-0.4497	*****	*****	*****	*****	*****
-0.950	0.2324	0.2511	0.2424	0.2047	-0.1472	*****	*****	*****	*****	*****
-0.975	*****	0.0398	0.0663	0.0754	-0.1062	*****	*****	*****	*****	*****
-1.000	-1.3092	-1.1718	-0.8560	-0.8346	-0.5298	*****	*****	*****	*****	*****

Medium Radius L.E.

Run No. = 27 , Point No. = 548

$C_N = 0.935$, $C_m = -0.1469$

$\alpha = 20.6^\circ$, $M_\infty = 0.869$

$R_{mac} = 59.7 \times 10^6$

Leading Edge Pressures

● starboard
○ port

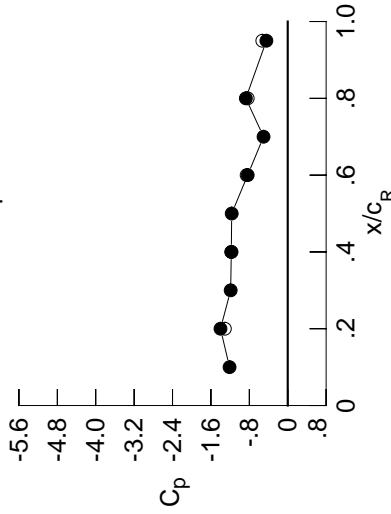

x/c_R	starb'd C_p	port C_p
0.10	-1.2122	*****
0.20	-1.4010	-1.3092
0.30	-1.1886	*****
0.40	-1.1760	-1.1718
0.50	-1.1670	*****
0.60	-0.8347	-0.8560
0.70	-0.5038	*****
0.80	-0.8728	-0.8346
0.90	*****	*****
0.95	-0.4446	-0.5298

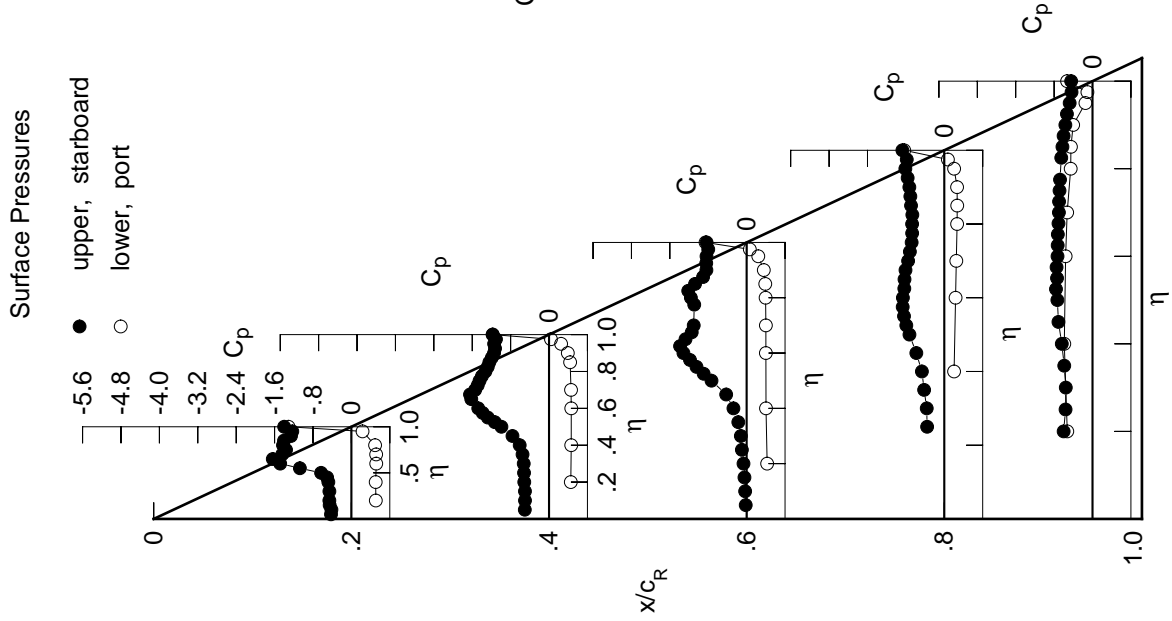
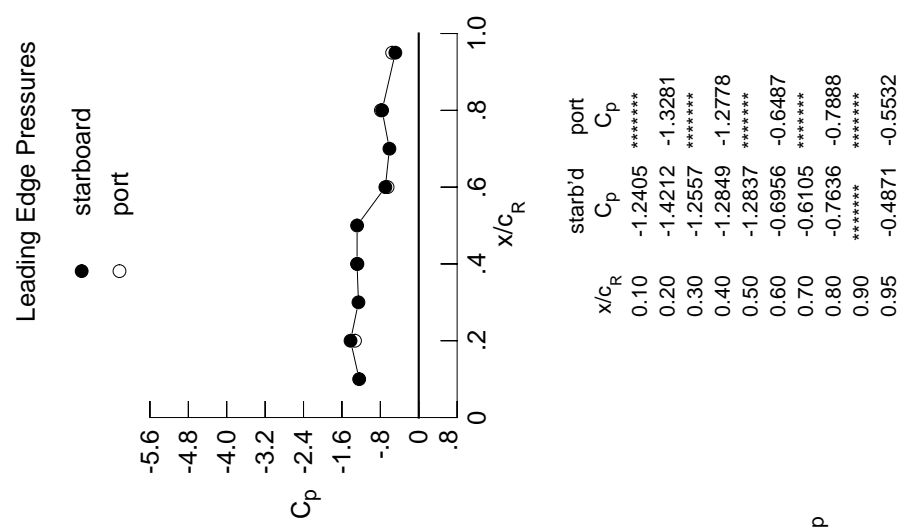

Table G3. Continued.

η	$x/c_R = .2$		$x/c_R = .4$		$x/c_R = .6$		$x/c_R = .8$		$x/c_R = .95$	
	$C_{p,u}$	$C_{p,u}$	$C_{p,u}$	$C_{p,u}$	$C_{p,u}$	$C_{p,u}$	$C_{p,u}$	$C_{p,u}$	$C_{p,u}$	$C_{p,u}$
0.050	-0.5006	-0.5673	0.0172	*****	*****	*****	*****	*****	*****	*****
0.100	-0.4942	-0.5697	0.0037	*****	*****	*****	*****	*****	*****	*****
0.150	-0.5303	-0.5676	-0.0110	*****	*****	*****	*****	*****	*****	*****
0.200	-0.5312	-0.5748	-0.0301	*****	*****	*****	*****	*****	*****	-0.6169
0.250	*****	-0.6098	-0.0679	-0.6012	-0.6314	*****	*****	*****	*****	*****
0.300	-0.5362	-0.6284	-0.1198	-0.6292	-0.6676	*****	*****	*****	*****	*****
0.350	*****	-0.6907	-0.2166	-0.7011	-0.7050	*****	*****	*****	*****	*****
0.400	-0.5851	-0.7979	-0.3791	-0.7606	-0.7637	*****	*****	*****	*****	*****
0.450	-0.7098	-0.9795	-0.5790	-0.8402	-0.8136	*****	*****	*****	*****	*****
0.500	-1.0289	-1.1811	-0.8951	-0.8935	-0.8020	*****	*****	*****	*****	*****
0.525	*****	-1.2916	-1.0385	-0.9056	-0.8136	*****	*****	*****	*****	*****
0.550	-1.4079	-1.4088	-1.1592	-0.9084	-0.7803	*****	*****	*****	*****	*****
0.575	*****	-1.4910	-1.2691	-0.9142	-0.7870	*****	*****	*****	*****	*****
0.600	-1.6344	-1.5611	-1.3789	-0.9152	-0.7650	*****	*****	*****	*****	*****
0.625	*****	*****	-1.3130	-0.9055	-0.7621	*****	*****	*****	*****	*****
0.650	-1.7249	-1.4706	-1.1339	-0.9108	-0.7548	*****	*****	*****	*****	*****
0.675	*****	-1.4431	-1.0569	-0.8946	-0.7392	*****	*****	*****	*****	*****
0.700	-1.6036	-1.4080	-1.0177	-0.8529	-0.7333	*****	*****	*****	*****	*****
0.725	*****	-1.3963	*****	-0.8311	-0.7288	*****	*****	*****	*****	*****
0.750	-1.4753	-1.3865	*****	-0.7982	-0.7176	*****	*****	*****	*****	*****
0.775	*****	-1.4020	-0.9590	-0.7874	-0.7042	*****	*****	*****	*****	*****
0.800	-1.3719	-1.4355	-0.9848	-0.7771	*****	*****	*****	*****	*****	*****
0.825	*****	-1.3784	-0.9961	-0.7758	-0.6678	*****	*****	*****	*****	*****
0.850	-1.3573	-1.2911	-0.8906	-0.7826	-0.6442	*****	*****	*****	*****	*****
0.875	*****	-1.2541	-0.8114	-0.7784	-0.6233	*****	*****	*****	*****	*****
0.900	-1.2844	-1.2550	-0.7653	-0.7717	-0.5961	*****	*****	*****	*****	*****
0.925	*****	-1.2434	-0.7437	-0.7555	-0.5812	*****	*****	*****	*****	*****
0.950	-1.2501	-1.2802	-0.7142	-0.7525	-0.5292	*****	*****	*****	*****	*****
0.975	*****	-1.2495	-0.6740	-0.7376	-0.4888	*****	*****	*****	*****	*****
1.000	-1.4212	-1.2849	-0.6956	-0.7636	-0.4871	*****	*****	*****	*****	*****
-0.200	$C_{p,l}$	$C_{p,l}$	$C_{p,l}$	$C_{p,l}$	$C_{p,l}$	$C_{p,l}$	$C_{p,l}$	$C_{p,l}$	$C_{p,l}$	$C_{p,l}$
-0.400	0.5685	0.5051	0.4694	*****	*****	*****	*****	*****	*****	-0.4938
-0.600	0.5657	0.5136	0.4456	0.2408	-0.5590	*****	*****	*****	*****	*****
-0.700	0.5718	0.5108	0.4423	0.2692	-0.5312	*****	*****	*****	*****	*****
-0.800	0.5646	0.5037	0.4411	0.2819	-0.4987	*****	*****	*****	*****	*****
-0.850	0.5300	*****	0.4311	0.2962	-0.4246	*****	*****	*****	*****	*****
-0.900	*****	0.4688	0.4197	0.2957	-0.4196	*****	*****	*****	*****	*****
-0.950	0.2234	0.2433	0.2484	0.2839	-0.3729	*****	*****	*****	*****	*****
-0.975	*****	0.0106	0.0602	0.0515	-0.1228	*****	*****	*****	*****	*****
-1.000	-1.3281	-1.2778	-0.6487	-0.7888	-0.5532	*****	*****	*****	*****	*****

Medium Radius L.E.
 Run No. = 27, Point No. = 549
 $C_N = 1.035$, $C_m = -0.1660$
 $\alpha = 22.6^\circ$, $M_\infty = 0.870$
 $R_{mac} = 59.6 \times 10^6$



x/c_R	starb'd C_p	port C_p
0.10	-1.2405	*****
0.20	-1.4212	-1.3281
0.30	-1.2557	*****
0.40	-1.2849	-1.2778
0.50	-1.2837	*****
0.60	-0.6956	-0.6487
0.70	-0.6105	*****
0.80	-0.7636	-0.7888
0.90	*****	*****
0.95	-0.4871	-0.5532

Table G3. Continued.

η	$x/c_R = .2$		$x/c_R = .4$		$x/c_R = .6$		$x/c_R = .8$		$x/c_R = .95$	
	$C_{p,u}$	$C_{p,u}$	$C_{p,u}$	$C_{p,u}$	$C_{p,u}$	$C_{p,u}$	$C_{p,u}$	$C_{p,u}$	$C_{p,u}$	$C_{p,u}$
0.050	-0.5872	-0.6530	-0.0040	*****	*****	*****	*****	*****	*****	*****
0.100	-0.5830	-0.6585	-0.0144	*****	*****	*****	*****	*****	*****	*****
0.150	-0.5888	-0.6638	-0.0271	*****	*****	*****	*****	*****	*****	*****
0.200	-0.6082	-0.6740	-0.0445	*****	*****	*****	*****	*****	*****	-0.5529
0.250	*****	-0.7089	-0.0892	-0.8841	-0.9275	-0.96720	*****	*****	*****	-0.5993
0.300	-0.6550	-0.7574	-0.1558	-0.9275	-0.9672	-0.9834	-0.7554	*****	*****	*****
0.350	*****	-0.8449	-0.2768	-0.9834	-0.9834	-0.9834	-0.7554	*****	*****	*****
0.400	-0.8142	-0.9792	-0.4671	-1.0205	-0.8601	*****	*****	*****	*****	*****
0.450	-1.0363	-1.1602	-0.6930	-1.0370	-0.8752	*****	*****	*****	*****	*****
0.500	-1.3358	-1.3298	-0.9827	-0.9902	-0.8036	*****	*****	*****	*****	*****
0.525	*****	-1.4146	-1.1061	-0.9551	-0.7938	*****	*****	*****	*****	*****
0.550	-1.5683	-1.5107	-1.2081	-0.9156	-0.7616	*****	*****	*****	*****	*****
0.575	*****	-1.5704	-1.2941	-0.9159	-0.7714	*****	*****	*****	*****	*****
0.600	-1.7043	-1.6248	-1.3620	-0.9298	-0.7722	*****	*****	*****	*****	*****
0.625	*****	*****	-1.2771	-0.9409	-0.7824	*****	*****	*****	*****	*****
0.650	-1.6027	-1.4888	-1.0915	-0.9594	-0.7784	*****	*****	*****	*****	*****
0.675	*****	-1.4252	-1.0112	-0.9691	-0.7630	*****	*****	*****	*****	*****
0.700	-1.6190	-1.4324	-0.9635	-0.9573	-0.7593	*****	*****	*****	*****	*****
0.725	*****	-1.4383	*****	-0.9557	-0.7560	*****	*****	*****	*****	*****
0.750	-1.5887	-1.4389	*****	-0.9320	-0.7452	*****	*****	*****	*****	*****
0.775	*****	-1.4710	-0.9270	-0.9181	-0.7339	*****	*****	*****	*****	*****
0.800	-1.3654	-1.4832	-0.8931	-0.8907	*****	*****	*****	*****	*****	*****
0.825	*****	-1.4203	-0.8829	-0.8852	-0.6889	*****	*****	*****	*****	*****
0.850	-1.3761	-1.3549	-0.8543	-0.8711	-0.6646	*****	*****	*****	*****	*****
0.875	*****	-1.3295	-0.8128	-0.8512	-0.6416	*****	*****	*****	*****	*****
0.900	-1.3123	-1.3266	-0.7648	-0.8342	-0.6145	*****	*****	*****	*****	*****
0.925	*****	-1.3359	-0.7236	-0.8113	-0.6015	*****	*****	*****	*****	*****
0.950	-1.2984	-1.3397	-0.6870	-0.7913	-0.5520	*****	*****	*****	*****	*****
0.975	*****	-1.3169	-0.6628	-0.7692	-0.5086	*****	*****	*****	*****	*****
1.000	-1.4555	-1.3486	-0.6672	-0.7667	-0.4876	*****	*****	*****	*****	*****
-0.200	$C_{p,l}$	$C_{p,l}$	$C_{p,l}$	$C_{p,l}$	$C_{p,l}$	$C_{p,l}$	$C_{p,l}$	$C_{p,l}$	$C_{p,l}$	$C_{p,l}$
-0.400	0.6232	0.5529	0.5060	*****	*****	*****	*****	*****	*****	-0.4629
-0.600	0.6204	0.5586	0.4825	0.2752	0.5324	*****	*****	*****	*****	-0.5324
-0.700	0.6212	0.5547	0.4773	0.3005	-0.5045	*****	*****	*****	*****	-0.5045
-0.800	0.6058	0.5432	0.4737	0.3125	-0.4703	*****	*****	*****	*****	-0.4703
-0.850	0.5586	*****	0.4585	0.3231	-0.3942	*****	*****	*****	*****	-0.3942
-0.900	*****	0.4912	0.4407	0.3190	-0.3880	*****	*****	*****	*****	-0.3880
-0.950	0.2058	0.2296	0.2346	0.1976	-0.1283	*****	*****	*****	*****	-0.1283
-0.975	*****	-0.0238	0.0274	0.0259	-0.1291	*****	*****	*****	*****	-0.1291
-1.000	-1.3729	-1.3501	-0.7037	-0.7084	-0.5363	*****	*****	*****	*****	-0.5363

Medium Radius L.E.
 Run No. = 27 , Point No. = 550
 $C_N = 1.131$, $C_m = -0.1790$
 $\alpha = 24.7^\circ$, $M_\infty = 0.869$
 $R_{mac} = 59.5 \times 10^6$

Leading Edge Pressures

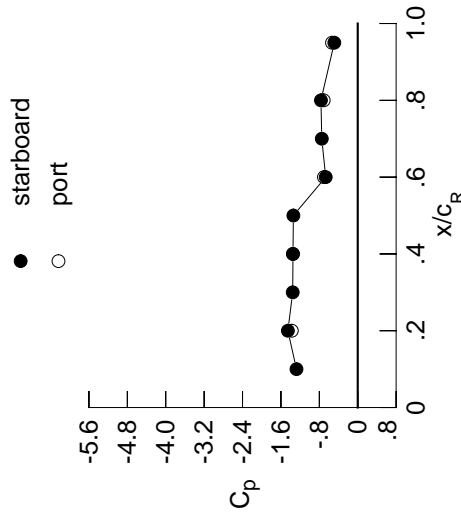

x/c_R	starb'd C_p	port C_p
0.10	-1.2759	*****
0.20	-1.4555	-1.3729
0.30	-1.3547	*****
0.40	-1.3486	-1.3501
0.50	-1.3410	*****
0.60	-0.6672	-0.7037
0.70	-0.7490	*****
0.80	-0.7667	-0.7084
0.90	*****	*****
0.95	-0.4876	-0.5363

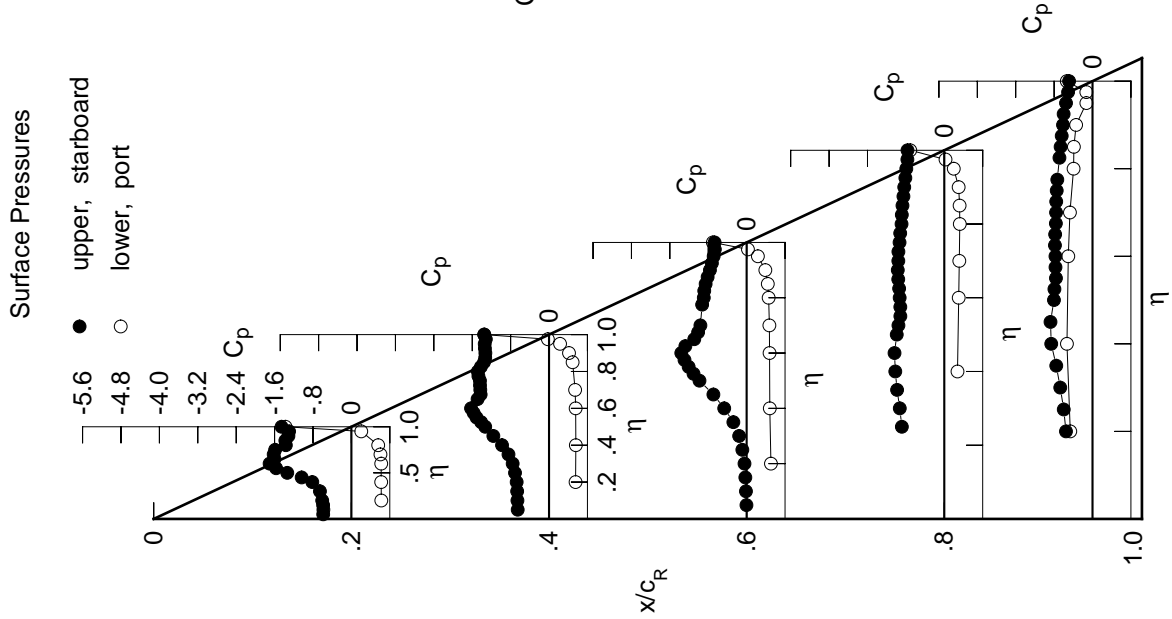
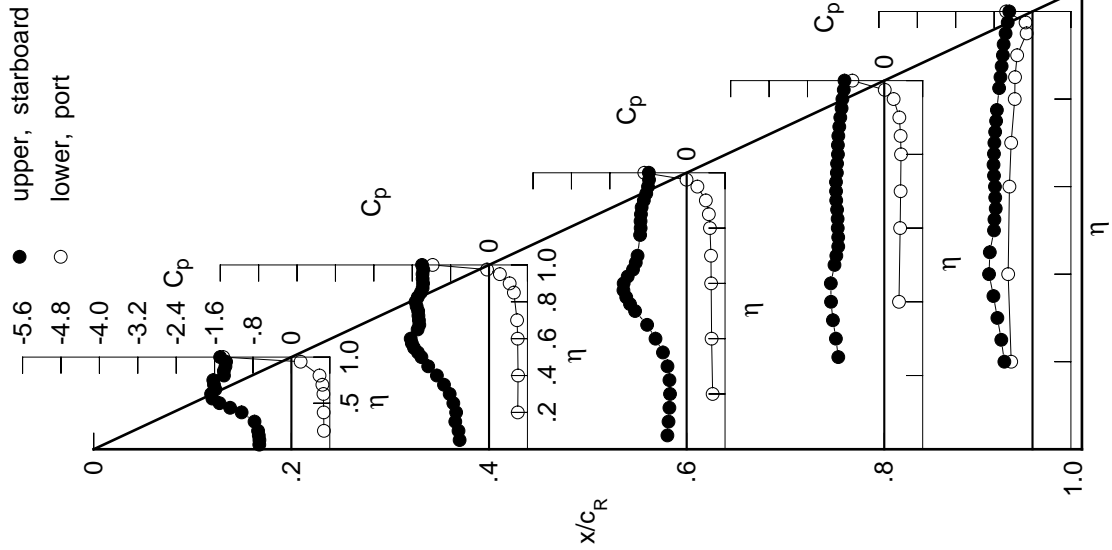

Table G3. Concluded.

η	x/c_R .2	x/c_R .4	x/c_R .6	x/c_R .8	x/c_R .95
	$C_{p,u}$	$C_{p,u}$	$C_{p,u}$	$C_{p,u}$	$C_{p,u}$
0.050	-0.6689	-0.6127	-0.4007	*****	*****
0.100	-0.6661	-0.6362	-0.3779	*****	*****
0.150	-0.6789	-0.7036	-0.3595	*****	*****
0.200	-0.6947	-0.6858	-0.3467	*****	-0.5866
0.250	*****	-0.7438	-0.3581	*****	-0.6500
0.300	-0.7681	-0.8198	-0.3990	-1.0080	-0.7323
0.350	*****	-0.9385	-0.4934	-1.0701	-0.8140
0.400	-1.0364	-1.0865	-0.6484	-1.1099	-0.9053
0.450	-1.2764	-1.2671	-0.8231	-1.1133	-0.8895
0.500	-1.4974	-1.4090	-1.0744	-1.0373	-0.8021
0.525	*****	-1.4809	-1.1788	-0.9994	-0.7935
0.550	-1.6465	-1.5621	-1.2580	-0.9590	-0.7660
0.575	*****	-1.6083	-1.3167	-0.9599	-0.7766
0.600	-1.6730	-1.6317	-1.3120	-0.9698	-0.7824
0.625	*****	*****	-1.2284	-0.9723	-0.8026
0.650	-1.5829	-1.4879	-1.1175	-0.9832	-0.8120
0.675	*****	-1.4529	-1.0598	-1.0019	-0.8034
0.700	-1.6124	-1.4606	-1.0222	-1.0049	-0.7944
0.725	*****	-1.4716	*****	-1.0064	-0.7787
0.750	-1.6271	-1.4766	*****	-0.9882	-0.7586
0.775	*****	-1.5082	-0.9698	-0.9837	-0.7424
0.800	-1.4048	-1.5311	-0.9581	-0.9657	*****
0.825	*****	-1.4848	-0.9603	-0.9663	-0.6962
0.850	-1.4074	-1.4213	-0.9524	-0.9574	-0.6684
0.875	*****	-1.3836	-0.9377	-0.9376	-0.6429
0.900	-1.3735	-1.3743	-0.8917	-0.9171	-0.6169
0.925	*****	-1.3831	-0.8414	-0.8898	-0.6018
0.950	-1.3608	-1.3859	-0.8044	-0.8726	-0.5604
0.975	*****	-1.3706	-0.7840	-0.8440	-0.5165
1.000	-1.4845	-1.3957	-0.7871	-0.8291	-0.4840
	$C_{p,l}$	$C_{p,l}$	$C_{p,l}$	$C_{p,l}$	$C_{p,l}$
-0.200	0.6775	0.5982	0.5419	*****	-0.4438
-0.400	0.6728	0.6047	0.5202	0.3062	-0.5074
-0.600	0.6676	0.5960	0.5108	0.3306	-0.4810
-0.700	0.6457	0.5838	0.5069	0.3403	-0.4452
-0.800	0.5857	*****	0.4857	0.3484	-0.3701
-0.850	*****	0.5173	0.4623	0.3403	-0.3644
-0.900	*****	0.4298	0.4002	0.3139	-0.3202
-0.950	0.1923	0.2259	0.2243	0.1947	-0.1227
-0.975	*****	-0.0417	-0.0023	0.0098	-0.1440
-1.000	-1.4193	-1.1752	-0.8816	-0.6651	-0.5490

Surface Pressures



Medium Radius L.E.
 Run No. = 27, Point No. = 551
 $C_N = 1.190$, $C_m = -0.1862$
 $\alpha = 26.8^\circ$, $M_\infty = 0.870$
 $R_{mac} = 59.5 \times 10^6$

Leading Edge Pressures

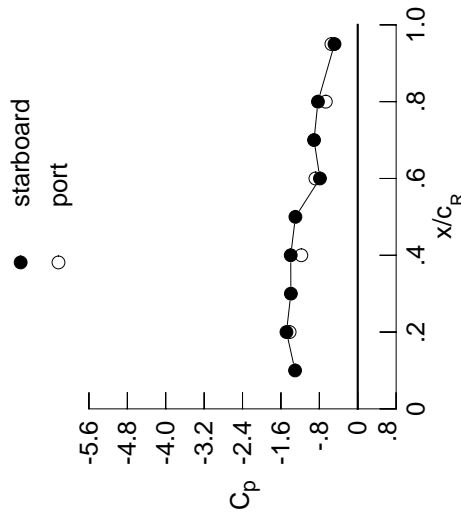

x/c_R	starb'd C_p	port C_p
0.10	-1.3059	*****
0.20	-1.4845	-1.4193
0.30	-1.3931	*****
0.40	-1.3957	-1.1752
0.50	-1.2980	*****
0.60	-0.7871	-0.8816
0.70	-0.9103	*****
0.80	-0.8291	-0.6651
0.90	*****	*****
0.95	-0.4840	-0.5490

Table G4. Tabulations and Plots of Surface Pressure Coefficients.

η	$x/c_R = .2$		$x/c_R = .4$		$x/c_R = .6$		$x/c_R = .8$		$x/c_R = .95$	
	$C_{p,u}$	$C_{p,u}$	$C_{p,u}$	$C_{p,u}$	$C_{p,u}$	$C_{p,u}$	$C_{p,u}$	$C_{p,u}$	$C_{p,u}$	$C_{p,u}$
0.050	0.0026	0.0173	0.1535	0.1535	0.1535	0.1535	0.1535	0.1535	0.1535	0.1535
0.100	0.0066	0.0177	0.1436	0.1436	0.1436	0.1436	0.1436	0.1436	0.1436	0.1436
0.150	0.0015	0.0180	0.1310	0.1310	0.1310	0.1310	0.1310	0.1310	0.1310	0.1310
0.200	0.0023	0.0214	0.1192	0.1192	0.1192	0.1192	0.1192	0.1192	0.1192	0.1192
0.250	0.0000	0.0164	0.1069	0.1069	0.1069	0.1069	0.1069	0.1069	0.1069	0.1069
0.300	-0.0049	0.0182	0.0974	0.0974	0.0974	0.0974	0.0974	0.0974	0.0974	0.0974
0.350	0.0000	0.0145	0.0870	0.0870	0.0870	0.0870	0.0870	0.0870	0.0870	0.0870
0.400	-0.0190	0.0151	0.0798	0.0798	0.0798	0.0798	0.0798	0.0798	0.0798	0.0798
0.450	-0.0253	0.0104	0.0860	0.0860	0.0860	0.0860	0.0860	0.0860	0.0860	0.0860
0.500	-0.0322	0.0126	0.0626	0.0626	0.0626	0.0626	0.0626	0.0626	0.0626	0.0626
0.525	0.0000	0.0083	0.0598	0.0598	0.0598	0.0598	0.0598	0.0598	0.0598	0.0598
0.550	-0.0317	0.0025	0.0558	0.0558	0.0558	0.0558	0.0558	0.0558	0.0558	0.0558
0.575	0.0000	0.0000	0.0612	0.0612	0.0612	0.0612	0.0612	0.0612	0.0612	0.0612
0.600	-0.0378	-0.0028	0.0487	0.0487	0.0487	0.0487	0.0487	0.0487	0.0487	0.0487
0.625	0.0000	0.0000	0.0476	0.0476	0.0476	0.0476	0.0476	0.0476	0.0476	0.0476
0.650	-0.0355	-0.0043	0.0431	0.0431	0.0431	0.0431	0.0431	0.0431	0.0431	0.0431
0.675	0.0000	-0.0149	0.0355	0.0355	0.0355	0.0355	0.0355	0.0355	0.0355	0.0355
0.700	-0.0306	-0.0219	0.0343	0.0343	0.0343	0.0343	0.0343	0.0343	0.0343	0.0343
0.725	0.0000	-0.0281	0.0281	0.0281	0.0281	0.0281	0.0281	0.0281	0.0281	0.0281
0.750	-0.0218	-0.0353	0.0222	0.0222	0.0222	0.0222	0.0222	0.0222	0.0222	0.0222
0.775	0.0000	-0.0382	0.0122	0.0122	0.0122	0.0122	0.0122	0.0122	0.0122	0.0122
0.800	-0.0013	-0.0422	0.0004	0.0004	0.0004	0.0004	0.0004	0.0004	0.0004	0.0004
0.825	0.0000	-0.0394	-0.0099	-0.0099	-0.0099	-0.0099	-0.0099	-0.0099	-0.0099	-0.0099
0.850	0.0214	-0.0336	-0.0188	-0.0188	-0.0188	-0.0188	-0.0188	-0.0188	-0.0188	-0.0188
0.875	0.0000	-0.0228	-0.0240	-0.0240	-0.0240	-0.0240	-0.0240	-0.0240	-0.0240	-0.0240
0.900	0.0563	-0.0110	-0.0201	-0.0201	-0.0201	-0.0201	-0.0201	-0.0201	-0.0201	-0.0201
0.925	0.0000	0.0145	-0.0062	-0.0062	-0.0062	-0.0062	-0.0062	-0.0062	-0.0062	-0.0062
0.950	0.1066	0.0508	0.0262	0.0262	0.0262	0.0262	0.0262	0.0262	0.0262	0.0262
0.975	0.0000	0.1050	0.0830	0.0830	0.0830	0.0830	0.0830	0.0830	0.0830	0.0830
1.000	0.2218	0.2160	0.2114	0.2114	0.2114	0.2114	0.2114	0.2114	0.2114	0.2114
-0.200	$C_{p,l}$	$C_{p,l}$	$C_{p,l}$	$C_{p,l}$	$C_{p,l}$	$C_{p,l}$	$C_{p,l}$	$C_{p,l}$	$C_{p,l}$	$C_{p,l}$
-0.400	-0.0261	-0.0018	0.0940	0.0940	0.0940	0.0940	0.0940	0.0940	0.0940	0.0940
-0.600	-0.0519	-0.0024	0.0531	0.0531	0.0531	0.0531	0.0531	0.0531	0.0531	0.0531
-0.700	-0.0773	-0.0640	-0.0035	-0.0035	-0.0035	-0.0035	-0.0035	-0.0035	-0.0035	-0.0035
-0.800	-0.0626	0.0000	-0.0490	-0.0490	-0.0490	-0.0490	-0.0490	-0.0490	-0.0490	-0.0490
-0.850	0.0000	-0.0957	-0.0816	-0.0816	-0.0816	-0.0816	-0.0816	-0.0816	-0.0816	-0.0816
-0.900	0.0000	-0.0839	-0.0981	-0.0981	-0.0981	-0.0981	-0.0981	-0.0981	-0.0981	-0.0981
-0.950	0.0385	-0.0359	-0.0691	-0.0691	-0.0691	-0.0691	-0.0691	-0.0691	-0.0691	-0.0691
-0.975	0.0000	0.0172	-0.0210	-0.0210	-0.0210	-0.0210	-0.0210	-0.0210	-0.0210	-0.0210
-1.000	0.1954	0.1916	0.1523	0.1523	0.1523	0.1523	0.1523	0.1523	0.1523	0.1523

Medium Radius L.E.
 Run No. = 28 , Point No. = 552
 $C_N = -0.022$, $C_m = -0.0022$
 $\alpha = -0.8^\circ$, $M_\infty = 0.900$
 $R_{mac} = 59.7 \times 10^6$

Surface Pressures
 ● upper, starboard
 ○ lower, port

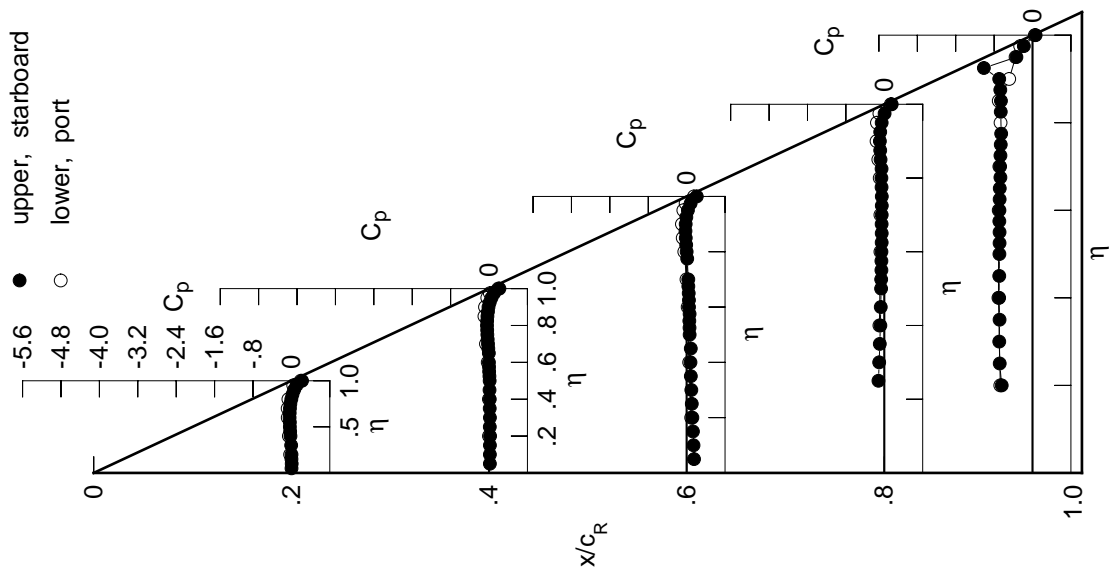

Leading Edge Pressures

● starboard
 ○ port

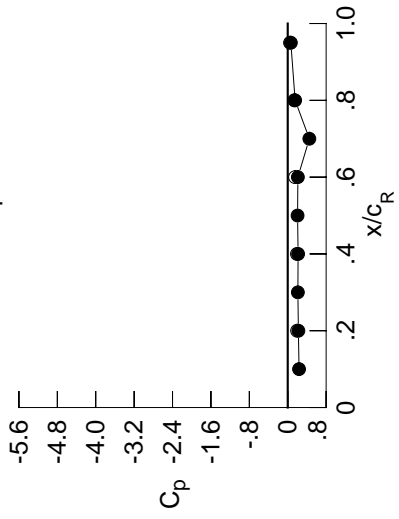

x/c_R	starb'd C_p	port C_p
0.10	0.2357	0.1954
0.20	0.2218	0.1954
0.30	0.2114	0.1916
0.40	0.2160	0.1916
0.50	0.2051	0.1523
0.60	0.2114	0.1523
0.70	0.4504	0.1541
0.80	0.1541	0.1359
0.90	0.0650	0.0477
0.95	0.0650	0.0477

Table G4. Continued.

η	$x/c_R = .2$		$x/c_R = .4$		$x/c_R = .6$		$x/c_R = .8$		$x/c_R = .95$	
	$C_{p,u}$	$C_{p,u}$	$C_{p,u}$	$C_{p,u}$	$C_{p,u}$	$C_{p,u}$	$C_{p,u}$	$C_{p,u}$	$C_{p,u}$	$C_{p,u}$
0.050	-0.0028	0.0119	0.1499	*****	*****	*****	*****	*****	*****	
0.100	-0.0010	0.0111	0.1397	*****	*****	*****	*****	*****	*****	
0.150	-0.0045	0.0127	0.1276	*****	*****	*****	*****	*****	*****	
0.200	-0.0042	0.0149	0.1153	*****	*****	*****	*****	*****	*****	
0.250	*****	0.0102	0.1033	-0.1257	-0.6830	*****	*****	*****	*****	
0.300	-0.0116	0.0109	0.0925	-0.1106	-0.6921	*****	*****	*****	*****	
0.350	*****	0.0084	0.0834	-0.0985	-0.6871	*****	*****	*****	*****	
0.400	-0.0270	0.0086	0.0755	-0.0852	-0.6956	*****	*****	*****	*****	
0.450	-0.0338	0.0034	0.0821	-0.0783	-0.6936	*****	*****	*****	*****	
0.500	-0.0411	0.0055	0.0566	-0.0709	-0.6904	*****	*****	*****	*****	
0.525	*****	0.0014	0.0554	-0.0703	-0.6886	*****	*****	*****	*****	
0.550	-0.0410	-0.0056	0.0497	-0.0651	-0.6869	*****	*****	*****	*****	
0.575	*****	-0.0080	0.0563	-0.0655	-0.6923	*****	*****	*****	*****	
0.600	-0.0481	-0.0116	0.0422	-0.0637	-0.6899	*****	*****	*****	*****	
0.625	*****	*****	0.0426	-0.0597	-0.6865	*****	*****	*****	*****	
0.650	-0.0466	-0.0127	0.0363	-0.0597	-0.6837	*****	*****	*****	*****	
0.675	*****	-0.0236	0.0287	-0.0607	-0.6714	*****	*****	*****	*****	
0.700	-0.0422	-0.0317	0.0268	-0.0603	-0.6772	*****	*****	*****	*****	
0.725	*****	-0.0392	*****	-0.0589	-0.6716	*****	*****	*****	*****	
0.750	-0.0343	-0.0465	*****	-0.0596	-0.6639	*****	*****	*****	*****	
0.775	*****	-0.0507	0.0024	-0.0638	-0.6569	*****	*****	*****	*****	
0.800	-0.0145	-0.0555	-0.0101	-0.0693	*****	*****	*****	*****	*****	
0.825	*****	-0.0536	-0.0232	-0.0671	-0.6659	*****	*****	*****	*****	
0.850	0.0074	-0.0499	-0.0330	-0.0887	-0.6604	*****	*****	*****	*****	
0.875	*****	-0.0400	-0.0402	-0.0988	-0.6779	*****	*****	*****	*****	
0.900	0.0411	-0.0286	-0.0383	-0.1086	-0.6744	*****	*****	*****	*****	
0.925	*****	-0.0050	-0.0264	-0.1038	-1.0132	*****	*****	*****	*****	
0.950	0.0917	0.0312	0.0041	-0.0773	-0.3466	*****	*****	*****	*****	
0.975	*****	0.0847	0.0599	-0.0174	-0.1985	*****	*****	*****	*****	
1.000	0.2262	0.2239	0.2311	0.1681	0.0761	*****	*****	*****	*****	
-0.200	$C_{p,l}$	$C_{p,l}$	$C_{p,l}$	$C_{p,l}$	$C_{p,l}$	$C_{p,l}$	$C_{p,l}$	$C_{p,l}$	$C_{p,l}$	
-0.400	-0.0172	0.0062	0.1002	*****	*****	-0.6677	*****	*****	*****	
-0.600	-0.0426	0.0058	0.0598	-0.0946	-0.7077	*****	*****	*****	*****	
-0.700	-0.0636	-0.0166	0.0299	-0.0729	-0.6989	*****	*****	*****	*****	
-0.800	-0.0631	-0.0519	0.0067	-0.0718	-0.6852	*****	*****	*****	*****	
-0.850	-0.0462	*****	-0.0363	-0.0834	-0.6576	*****	*****	*****	*****	
-0.900	*****	-0.0770	-0.0652	-0.1095	-0.6945	*****	*****	*****	*****	
-0.950	*****	-0.0623	-0.0769	-0.1411	-0.5080	*****	*****	*****	*****	
-0.975	0.0588	-0.0111	-0.0419	-0.1251	-0.3359	*****	*****	*****	*****	
-1.000	0.2027	0.2039	0.1690	0.1589	0.0642	*****	*****	*****	*****	

Medium Radius L.E.
 Run No. = 28 , Point No. = 553
 $C_N = -0.005$, $C_m = -0.0055$
 $\alpha = -0.4^\circ$, $M_\infty = 0.901$
 $R_{mac} = 59.8 \times 10^6$

Leading Edge Pressures

● starboard
 ○ port

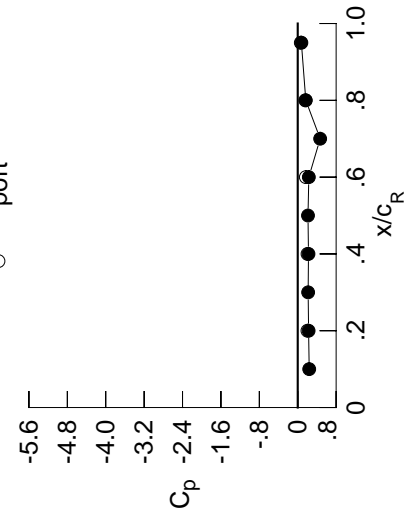

x/c_R	starb'd C_p	port C_p
0.10	0.2388	*****
0.20	0.2262	0.2027
0.30	0.2170	*****
0.40	0.2239	0.2039
0.50	0.2138	*****
0.60	0.2311	0.1690
0.70	0.4675	*****
0.80	0.1681	0.1589
0.90	*****	*****
0.95	0.0761	0.0642

Surface Pressures

● upper, starboard
 ○ lower, port

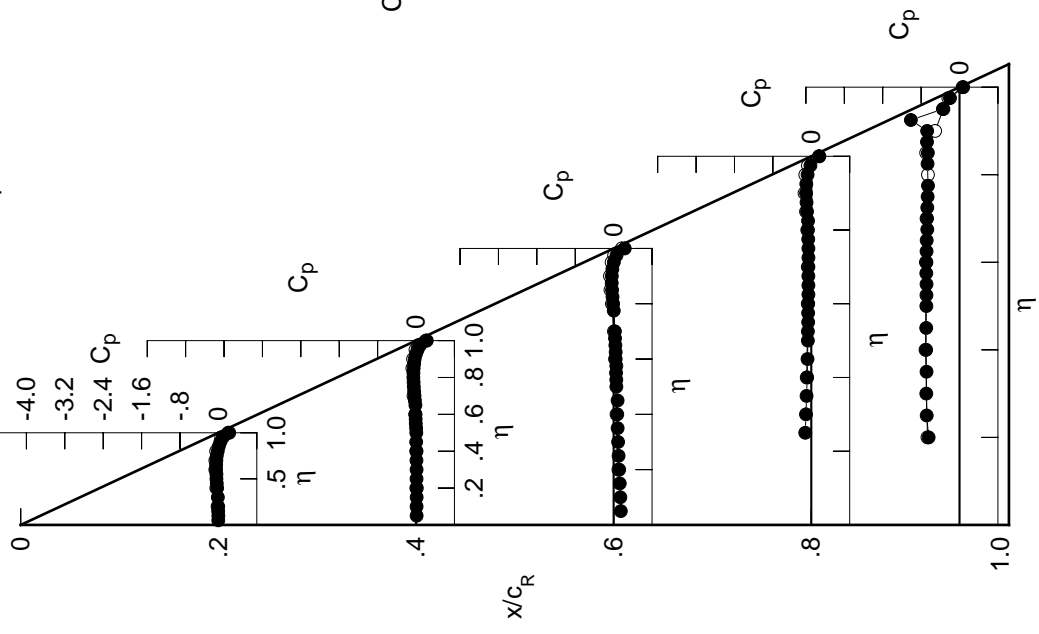

Table G4. Continued.

η	$x/c_R = .2$		$x/c_R = .4$		$x/c_R = .6$		$x/c_R = .8$		$x/c_R = .95$	
	$C_{p,u}$	$C_{p,u}$	$C_{p,u}$	$C_{p,u}$	$C_{p,u}$	$C_{p,u}$	$C_{p,u}$	$C_{p,u}$	$C_{p,u}$	$C_{p,u}$
0.050	-0.0232	-0.0063	0.1363	*****	*****	*****	*****	*****	*****	*****
0.100	-0.0203	-0.0067	0.1271	*****	*****	*****	*****	*****	*****	*****
0.150	-0.0245	-0.0059	0.1147	*****	*****	*****	*****	*****	*****	*****
0.200	-0.0248	-0.0031	0.1024	*****	*****	*****	*****	*****	*****	*****
0.250	*****	-0.0085	0.0900	-0.1412	-0.6873	*****	*****	*****	*****	*****
0.300	-0.0323	-0.0073	0.0791	-0.1257	-0.6965	*****	*****	*****	*****	*****
0.350	*****	-0.0107	0.0691	-0.1138	-0.6906	*****	*****	*****	*****	*****
0.400	-0.0502	-0.0115	0.0602	-0.1012	-0.7013	*****	*****	*****	*****	*****
0.450	-0.0585	-0.0164	0.0661	-0.0940	-0.6992	*****	*****	*****	*****	*****
0.500	-0.0671	-0.0162	0.0403	-0.0875	-0.6977	*****	*****	*****	*****	*****
0.525	*****	-0.0207	0.0383	-0.0868	-0.6952	*****	*****	*****	*****	*****
0.550	-0.0691	-0.0291	0.0320	-0.0820	-0.6955	*****	*****	*****	*****	*****
0.575	*****	-0.0305	0.0377	-0.0839	-0.7001	*****	*****	*****	*****	*****
0.600	-0.0779	-0.0364	0.0230	-0.0823	-0.6983	*****	*****	*****	*****	*****
0.625	*****	*****	0.0225	-0.0792	-0.6957	*****	*****	*****	*****	*****
0.650	-0.0789	-0.0396	0.0155	-0.0783	-0.6926	*****	*****	*****	*****	*****
0.675	*****	-0.0518	0.0070	-0.0812	-0.6806	*****	*****	*****	*****	*****
0.700	-0.0780	-0.0622	0.0039	-0.0814	-0.6871	*****	*****	*****	*****	*****
0.725	*****	-0.0720	*****	-0.0811	-0.6825	*****	*****	*****	*****	*****
0.750	-0.0723	-0.0814	*****	-0.0827	-0.6767	*****	*****	*****	*****	*****
0.775	*****	-0.0890	-0.0270	-0.0901	-0.6705	*****	*****	*****	*****	*****
0.800	-0.0544	-0.0966	-0.0431	-0.0980	*****	*****	*****	*****	*****	*****
0.825	*****	-0.0983	-0.0603	-0.0965	-0.6794	*****	*****	*****	*****	*****
0.850	-0.0352	-0.0979	-0.0748	-0.1239	-0.6686	*****	*****	*****	*****	*****
0.875	*****	-0.0910	-0.0882	-0.1404	-0.6984	*****	*****	*****	*****	*****
0.900	-0.0040	-0.0838	-0.0923	-0.1581	-0.5492	*****	*****	*****	*****	*****
0.925	*****	-0.0641	-0.0872	-0.1619	-0.8925	*****	*****	*****	*****	*****
0.950	0.0434	-0.0321	-0.0640	-0.1434	-0.3848	*****	*****	*****	*****	*****
0.975	*****	0.0182	-0.0138	-0.0936	-0.2573	*****	*****	*****	*****	*****
1.000	0.2197	0.2129	0.2230	0.1533	0.0654	*****	*****	*****	*****	*****
-0.200	$C_{p,l}$	$C_{p,l}$	$C_{p,l}$	$C_{p,l}$	$C_{p,l}$	$C_{p,l}$	$C_{p,l}$	$C_{p,l}$	$C_{p,l}$	$C_{p,l}$
-0.400	0.0030	0.0245	0.1130	*****	-0.6633	*****	*****	*****	*****	*****
-0.600	-0.0197	0.0251	0.0738	-0.0799	-0.7021	*****	*****	*****	*****	*****
-0.700	-0.0340	0.0069	0.0476	-0.0564	-0.6923	*****	*****	*****	*****	*****
-0.800	-0.0296	-0.0224	0.0285	-0.0517	-0.6756	*****	*****	*****	*****	*****
-0.850	-0.0069	*****	-0.0046	-0.0573	-0.6435	*****	*****	*****	*****	*****
-0.900	*****	-0.0319	-0.0247	-0.0752	-0.6744	*****	*****	*****	*****	*****
-0.950	*****	-0.0101	-0.0254	-0.0933	-0.6689	*****	*****	*****	*****	*****
-0.975	0.1046	0.0468	0.0214	-0.0610	-0.3010	*****	*****	*****	*****	*****
-1.000	0.2020	0.2011	0.1657	0.1606	0.0664	*****	*****	*****	*****	*****

Medium Radius L.E.
 Run No. = 28 , Point No. = 554
 $C_N = 0.039$, $C_m = -0.0136$
 $\alpha = 0.7^\circ$, $M_\infty = 0.901$
 $R_{mac} = 59.9 \times 10^6$

Leading Edge Pressures

● starboard
 ○ port

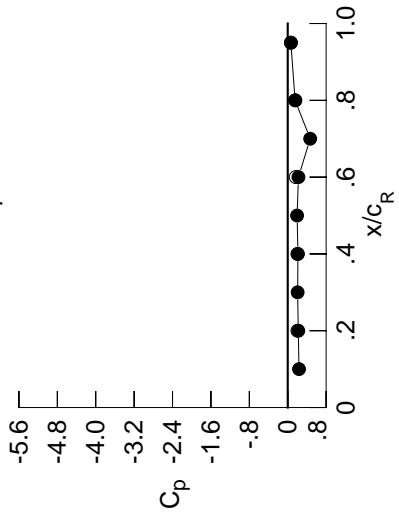

x/c_R	starb'd C_p	port C_p
0.10	0.2350	*****
0.20	0.2197	0.2020
0.30	0.2062	*****
0.40	0.2129	0.2011
0.50	0.1953	*****
0.60	0.2230	0.1657
0.70	0.4682	*****
0.80	0.1533	0.1606
0.90	*****	*****
0.95	0.0654	0.0664

Surface Pressures
 ● upper, starboard
 ○ lower, port

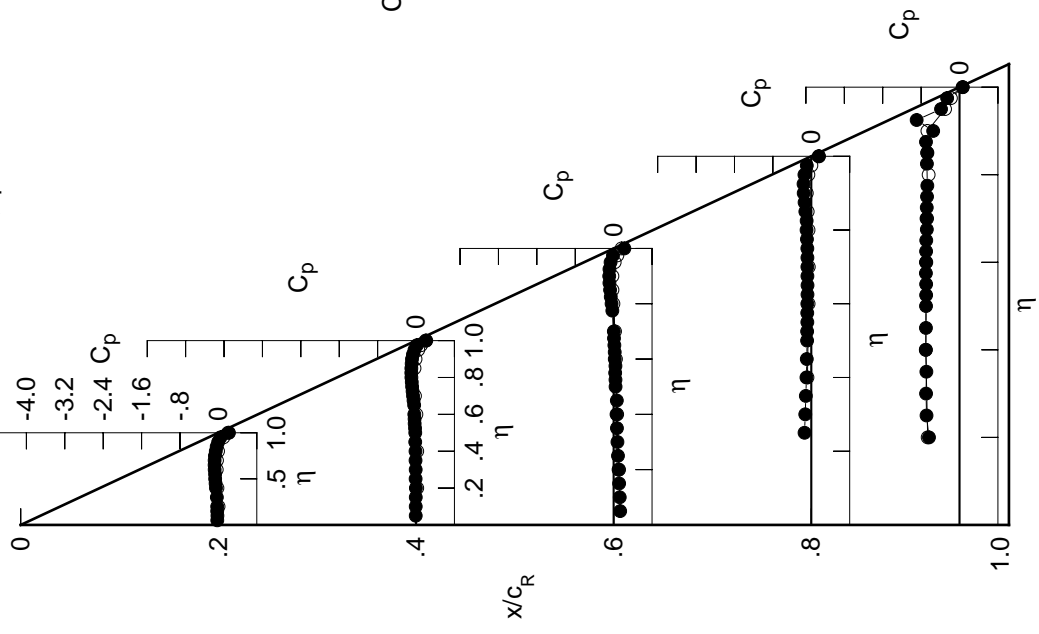

Table G4. Continued.

η	$x/c_R = .2$		$x/c_R = .4$		$x/c_R = .6$		$x/c_R = .8$		$x/c_R = .95$	
	$C_{p,u}$	$C_{p,u}$	$C_{p,u}$	$C_{p,u}$	$C_{p,u}$	$C_{p,u}$	$C_{p,u}$	$C_{p,u}$	$C_{p,u}$	$C_{p,u}$
0.050	-0.0373	-0.0181	0.1292	0.1292	0.1292	0.1292	0.1292	0.1292	0.1292	0.1292
0.100	-0.0328	-0.0181	0.1217	0.1217	0.1217	0.1217	0.1217	0.1217	0.1217	0.1217
0.150	-0.0390	-0.0193	0.1069	0.1069	0.1069	0.1069	0.1069	0.1069	0.1069	0.1069
0.200	-0.0389	-0.0146	0.0948	0.0948	0.0948	0.0948	0.0948	0.0948	0.0948	0.0948
0.250	*****	-0.0205	0.0817	0.0817	0.0817	0.0817	0.0817	0.0817	0.0817	0.0817
0.300	-0.0467	-0.0197	0.0705	0.0705	0.0705	0.0705	0.0705	0.0705	0.0705	0.0705
0.350	*****	-0.0244	0.0588	0.0588	0.0588	0.0588	0.0588	0.0588	0.0588	0.0588
0.400	-0.0670	-0.0249	0.0504	0.0504	0.0504	0.0504	0.0504	0.0504	0.0504	0.0504
0.450	-0.0776	-0.0321	0.0567	0.0567	0.0567	0.0567	0.0567	0.0567	0.0567	0.0567
0.500	-0.0875	-0.0315	0.0288	0.0288	0.0288	0.0288	0.0288	0.0288	0.0288	0.0288
0.525	*****	-0.0381	0.0262	0.0262	0.0262	0.0262	0.0262	0.0262	0.0262	0.0262
0.550	-0.0912	-0.0468	0.0195	0.0195	0.0195	0.0195	0.0195	0.0195	0.0195	0.0195
0.575	*****	-0.0494	0.0244	0.0244	0.0244	0.0244	0.0244	0.0244	0.0244	0.0244
0.600	-0.1028	-0.0558	0.0084	0.0084	0.0084	0.0084	0.0084	0.0084	0.0084	0.0084
0.625	*****	*****	0.0072	0.0072	0.0072	0.0072	0.0072	0.0072	0.0072	0.0072
0.650	-0.1079	-0.0603	-0.0009	-0.0009	-0.0009	-0.0009	-0.0009	-0.0009	-0.0009	-0.0009
0.675	*****	-0.0744	-0.0103	-0.0103	-0.0103	-0.0103	-0.0103	-0.0103	-0.0103	-0.0103
0.700	-0.1085	-0.0875	-0.0150	-0.0150	-0.0150	-0.0150	-0.0150	-0.0150	-0.0150	-0.0150
0.725	*****	-0.0995	*****	*****	*****	*****	*****	*****	*****	*****
0.750	-0.1061	-0.1125	*****	*****	*****	*****	*****	*****	*****	*****
0.775	*****	-0.1230	-0.0531	-0.1114	-0.06927	*****	*****	*****	*****	*****
0.800	-0.0918	-0.1349	-0.0727	-0.1213	*****	*****	*****	*****	*****	*****
0.825	*****	-0.1393	-0.0954	-0.1224	-0.6912	*****	*****	*****	*****	*****
0.850	-0.0762	-0.1445	-0.1162	-0.1560	-0.6713	*****	*****	*****	*****	*****
0.875	*****	-0.1430	-0.1364	-0.1815	-0.5776	*****	*****	*****	*****	*****
0.900	-0.0491	-0.1404	-0.1488	-0.2083	-0.4457	*****	*****	*****	*****	*****
0.925	*****	-0.1267	-0.1524	-0.2221	-0.6111	*****	*****	*****	*****	*****
0.950	-0.0073	-0.0990	-0.1399	-0.2180	-0.4342	*****	*****	*****	*****	*****
0.975	*****	-0.0601	-0.1021	-0.1835	-0.3290	*****	*****	*****	*****	*****
1.000	0.1949	0.1579	0.1413	0.0652	-0.0017	*****	*****	*****	*****	*****
	$C_{p,l}$	$C_{p,l}$	$C_{p,l}$	$C_{p,l}$	$C_{p,l}$	$C_{p,l}$	$C_{p,l}$	$C_{p,l}$	$C_{p,l}$	$C_{p,l}$
-0.200	0.0318	0.0522	0.1328	0.1328	0.1328	0.1328	0.1328	0.1328	0.1328	0.1328
-0.400	0.0120	0.0543	0.0967	0.0967	0.0967	0.0967	0.0967	0.0967	0.0967	0.0967
-0.600	0.0031	0.0392	0.0738	0.0738	0.0738	0.0738	0.0738	0.0738	0.0738	0.0738
-0.700	0.0122	0.0148	0.0579	0.0579	0.0579	0.0579	0.0579	0.0579	0.0579	0.0579
-0.800	0.0381	*****	0.0323	0.0251	-0.6352	*****	*****	*****	*****	*****
-0.850	*****	0.0189	0.0202	0.0361	-0.6610	*****	*****	*****	*****	*****
-0.900	*****	0.0459	0.0274	0.0426	-0.7151	*****	*****	*****	*****	*****
-0.950	0.1536	0.1056	0.0824	0.0013	-0.2725	*****	*****	*****	*****	*****
-0.975	*****	0.1615	0.1390	0.0671	-0.1335	*****	*****	*****	*****	*****
-1.000	0.1791	0.1582	0.0946	0.0918	0.0182	*****	*****	*****	*****	*****

Medium Radius L.E.
 Run No. = 28 , Point No. = 555
 $C_N = 0.079$, $C_m = -0.0182$
 $\alpha = 1.8^\circ$, $M_\infty = 0.889$
 $R_{mac} = 59.6 \times 10^6$

Leading Edge Pressures

● starboard
 ○ port

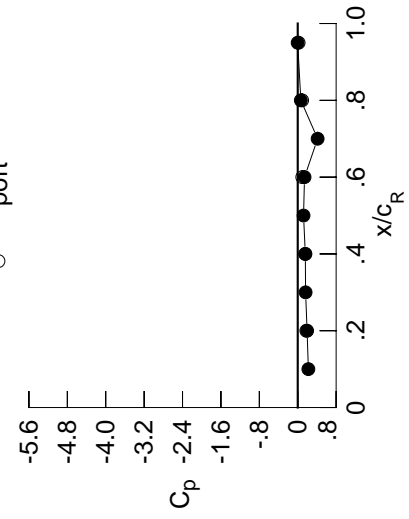

x/c_R	starb'd C_p	port C_p
0.10	0.2214	*****
0.20	0.1949	0.1791
0.30	0.1640	*****
0.40	0.1579	0.1582
0.50	0.1211	*****
0.60	0.1413	0.0946
0.70	0.4144	*****
0.80	0.0652	0.0918
0.90	*****	*****
0.95	-0.0017	0.0182

Surface Pressures

● upper, starboard
 ○ lower, port

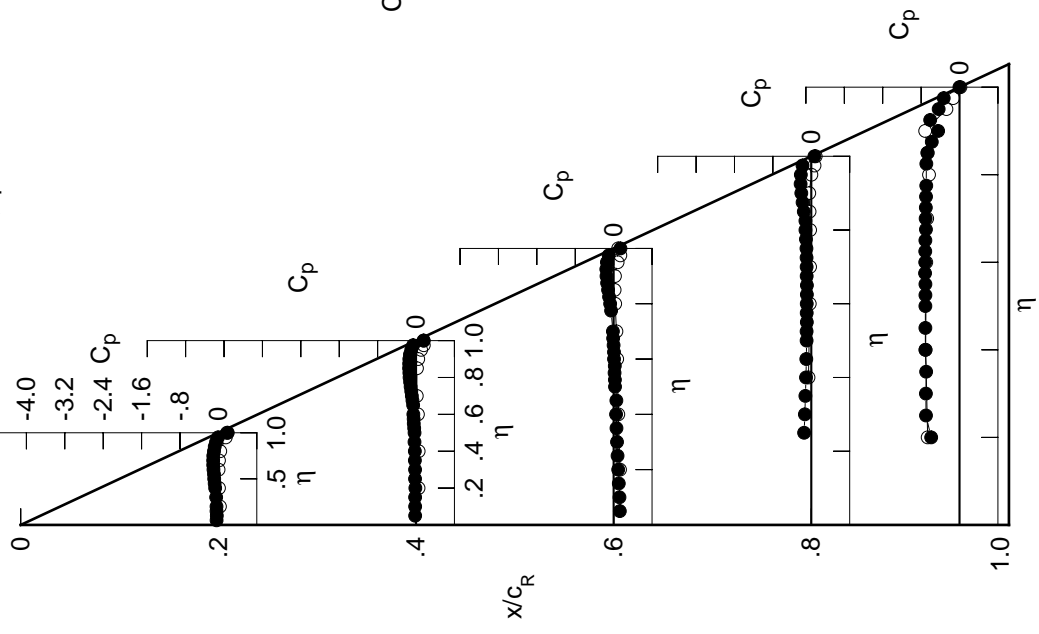

Table G4. Continued.

η	$x/c_R = .2$		$x/c_R = .4$		$x/c_R = .6$		$x/c_R = .8$		$x/c_R = .95$	
	$C_{p,u}$	$C_{p,u}$	$C_{p,u}$	$C_{p,u}$	$C_{p,u}$	$C_{p,u}$	$C_{p,u}$	$C_{p,u}$	$C_{p,u}$	$C_{p,u}$
0.050	-0.0623	-0.0429	0.1116	*****	*****	*****	*****	*****	*****	
0.100	-0.0597	-0.0433	0.1041	*****	*****	*****	*****	*****	*****	
0.150	-0.0647	-0.0427	0.0890	*****	*****	*****	*****	*****	*****	
0.200	-0.0655	-0.0409	0.0776	*****	*****	*****	*****	*****	-0.6168	
0.250	*****	-0.0453	0.0635	-0.1727	-0.6922	*****	*****	*****	*****	
0.300	-0.0742	-0.0463	0.0520	-0.1568	-0.6944	*****	*****	*****	*****	
0.350	*****	-0.0506	0.0404	-0.1459	-0.6908	*****	*****	*****	*****	
0.400	-0.0962	-0.0516	0.0312	-0.1332	-0.7096	*****	*****	*****	*****	
0.450	-0.1087	-0.0595	0.0353	-0.1265	-0.7114	*****	*****	*****	*****	
0.500	-0.1199	-0.0609	0.0078	-0.1214	-0.7106	*****	*****	*****	*****	
0.525	*****	-0.0672	0.0039	-0.1212	-0.7094	*****	*****	*****	*****	
0.550	-0.1261	-0.0766	-0.0034	-0.1193	-0.7103	*****	*****	*****	*****	
0.575	*****	-0.0813	0.0016	-0.1191	-0.7149	*****	*****	*****	*****	
0.600	-0.1398	-0.0877	-0.0156	-0.1206	-0.7156	*****	*****	*****	*****	
0.625	*****	*****	-0.0172	-0.1177	-0.7126	*****	*****	*****	*****	
0.650	-0.1464	-0.0938	-0.0266	-0.1187	-0.7112	*****	*****	*****	*****	
0.675	*****	-0.1116	-0.0372	-0.1232	-0.6991	*****	*****	*****	*****	
0.700	-0.1509	-0.1256	-0.0434	-0.1259	-0.7075	*****	*****	*****	*****	
0.725	*****	-0.1414	*****	-0.1278	-0.7031	*****	*****	*****	*****	
0.750	-0.1512	-0.1557	*****	-0.1343	-0.7016	*****	*****	*****	*****	
0.775	*****	-0.1708	-0.0888	-0.1454	-0.6977	*****	*****	*****	*****	
0.800	-0.1416	-0.1856	-0.1135	-0.1593	*****	*****	*****	*****	*****	
0.825	*****	-0.1955	-0.1399	-0.1617	-0.6948	*****	*****	*****	*****	
0.850	-0.1297	-0.2039	-0.1685	-0.2023	-0.5893	*****	*****	*****	*****	
0.875	*****	-0.2082	-0.1948	-0.2335	-0.4356	*****	*****	*****	*****	
0.900	-0.1090	-0.2109	-0.2177	-0.2719	-0.4132	*****	*****	*****	*****	
0.925	*****	-0.2032	-0.2305	-0.2977	-0.4914	*****	*****	*****	*****	
0.950	-0.0743	-0.1855	-0.2311	-0.3075	-0.4824	*****	*****	*****	*****	
0.975	*****	-0.1594	-0.2110	-0.2935	-0.4147	*****	*****	*****	*****	
1.000	0.1283	0.0414	-0.0093	-0.1012	-0.1366	*****	*****	*****	*****	
η	$C_{p,l}$	$C_{p,l}$	$C_{p,l}$	$C_{p,l}$	$C_{p,l}$	$C_{p,l}$	$C_{p,l}$	$C_{p,l}$	$C_{p,l}$	
-0.200	0.0460	0.0624	0.1409	*****	-0.6519	*****	*****	*****	*****	
-0.400	0.0279	0.0663	0.1049	-0.0501	-0.6898	*****	*****	*****	*****	
-0.600	0.0247	0.0539	0.0860	-0.0218	-0.6773	*****	*****	*****	*****	
-0.700	0.0367	0.0361	0.0734	-0.0128	-0.6562	*****	*****	*****	*****	
-0.800	0.0662	*****	0.0549	-0.0069	-0.6162	*****	*****	*****	*****	
-0.850	*****	0.0508	0.0486	-0.0126	-0.6347	*****	*****	*****	*****	
-0.900	*****	0.0817	0.0642	-0.0097	-0.6696	*****	*****	*****	*****	
-0.950	0.1789	0.1392	0.1205	0.0423	-0.2465	*****	*****	*****	*****	
-0.975	*****	0.1884	0.1712	0.1032	-0.1025	*****	*****	*****	*****	
-1.000	0.1144	0.0481	-0.0633	-0.0612	-0.0931	*****	*****	*****	*****	

Medium Radius L.E.
 Run No. = 28 , Point No. = 556
 $C_N = 0.125$, $C_m = -0.0269$
 $\alpha = 2.8^\circ$, $M_\infty = 0.900$
 $R_{mac} = 60.3 \times 10^6$

Leading Edge Pressures

● starboard
 ○ port

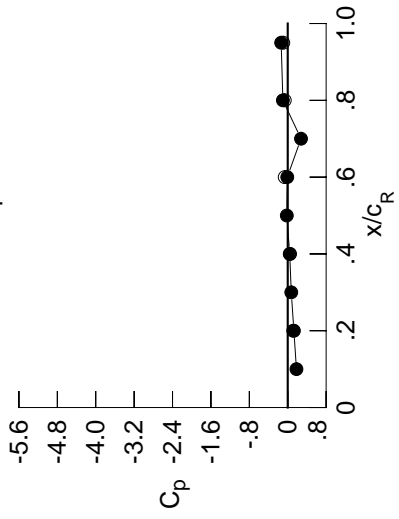

x/c_R	starb'd C_p	port C_p
0.10	0.1815	*****
0.20	0.1283	0.1144
0.30	0.0736	*****
0.40	0.0414	0.0481
0.50	-0.0193	*****
0.60	-0.0093	-0.0633
0.70	0.2768	*****
0.80	-0.1012	-0.0612
0.90	*****	*****
0.95	-0.1366	-0.0931

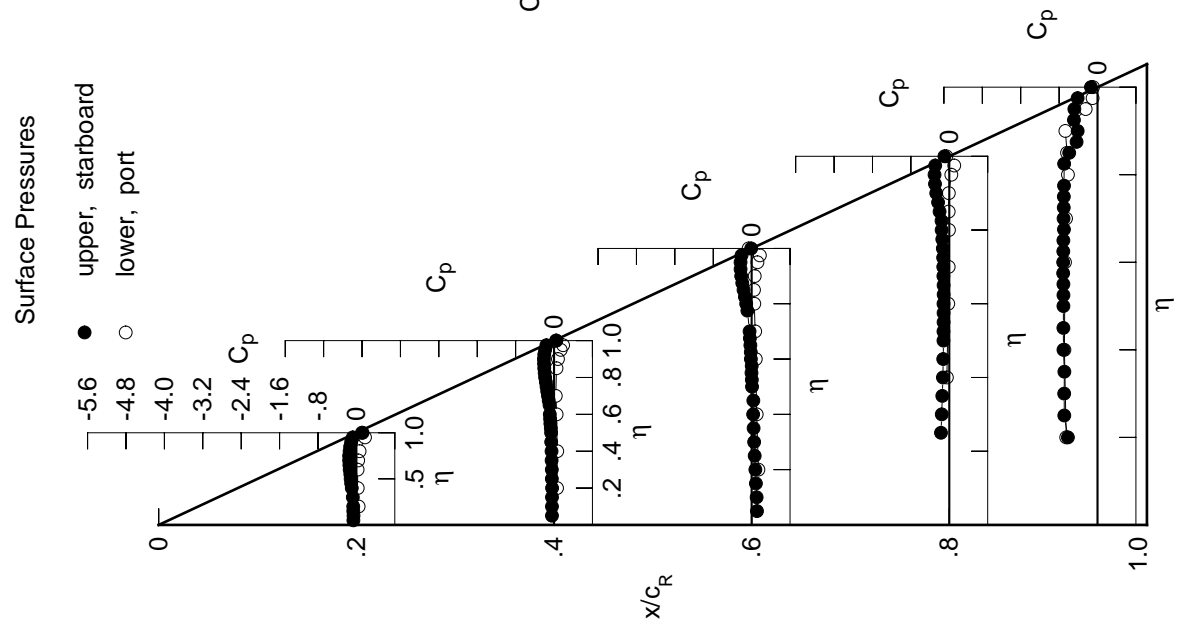

Table G4. Continued.

η	$x/c_R = .2$		$x/c_R = .4$		$x/c_R = .6$		$x/c_R = .8$		$x/c_R = .95$	
	$C_{p,u}$	$C_{p,u}$	$C_{p,u}$	$C_{p,u}$	$C_{p,u}$	$C_{p,u}$	$C_{p,u}$	$C_{p,u}$	$C_{p,u}$	$C_{p,u}$
0.050	-0.0802	-0.0614	0.1004	*****	*****	*****	*****	*****	*****	
0.100	-0.0777	-0.0598	0.0908	*****	*****	*****	*****	*****	*****	
0.150	-0.0836	-0.0612	0.0769	*****	*****	*****	*****	*****	*****	
0.200	-0.0832	-0.0582	0.0654	*****	*****	*****	*****	*****	-0.5992	
0.250	*****	-0.0643	0.0512	-0.1879	-0.1879	-0.1879	-0.1879	-0.1879	-0.6909	
0.300	-0.0943	-0.0652	0.0390	-0.1722	-0.1722	-0.1722	-0.1722	-0.1722	-0.6871	
0.350	*****	-0.0698	0.0256	-0.1615	-0.1615	-0.1615	-0.1615	-0.1615	-0.6909	
0.400	-0.1188	-0.0731	0.0172	-0.1488	-0.1488	-0.1488	-0.1488	-0.1488	-0.7111	
0.450	-0.1324	-0.0810	0.0187	-0.1428	-0.1428	-0.1428	-0.1428	-0.1428	-0.7102	
0.500	-0.1453	-0.0835	-0.0086	-0.1389	-0.1389	-0.1389	-0.1389	-0.1389	-0.7121	
0.525	*****	-0.0904	-0.0128	-0.1387	-0.1387	-0.1387	-0.1387	-0.1387	-0.7141	
0.550	-0.1545	-0.1014	-0.0211	-0.1369	-0.1369	-0.1369	-0.1369	-0.1369	-0.7146	
0.575	*****	-0.1059	-0.0177	-0.1376	-0.1376	-0.1376	-0.1376	-0.1376	-0.7215	
0.600	-0.1705	-0.1150	-0.0348	-0.1391	-0.1391	-0.1391	-0.1391	-0.1391	-0.7205	
0.625	*****	*****	-0.0375	-0.1370	-0.1370	-0.1370	-0.1370	-0.1370	-0.7196	
0.650	-0.1807	-0.1234	-0.0482	-0.1396	-0.1396	-0.1396	-0.1396	-0.1396	-0.7188	
0.675	*****	-0.1413	-0.0597	-0.1466	-0.1466	-0.1466	-0.1466	-0.1466	-0.7078	
0.700	-0.1885	-0.1575	-0.0688	-0.1494	-0.1494	-0.1494	-0.1494	-0.1494	-0.7166	
0.725	*****	-0.1759	*****	-0.1537	-0.1537	-0.1537	-0.1537	-0.1537	-0.7136	
0.750	-0.1929	-0.1945	*****	-0.1605	-0.1605	-0.1605	-0.1605	-0.1605	-0.7138	
0.775	*****	-0.2135	-0.1216	-0.1747	-0.1747	-0.1747	-0.1747	-0.1747	-0.7098	
0.800	-0.1876	-0.2318	-0.1504	-0.1916	-0.1916	-0.1916	-0.1916	-0.1916	*****	
0.825	*****	-0.2471	-0.1810	-0.1954	-0.1954	-0.1954	-0.1954	-0.1954	-0.6628	
0.850	-0.1812	-0.2595	-0.2169	-0.2422	-0.2422	-0.2422	-0.2422	-0.2422	-0.4676	
0.875	*****	-0.2713	-0.2516	-0.2819	-0.2819	-0.2819	-0.2819	-0.2819	-0.3811	
0.900	-0.1667	-0.2807	-0.2858	-0.3314	-0.3314	-0.3314	-0.3314	-0.3314	-0.3906	
0.925	*****	-0.2826	-0.3106	-0.3696	-0.3696	-0.3696	-0.3696	-0.3696	-0.4298	
0.950	-0.1426	-0.2741	-0.3284	-0.3987	-0.3987	-0.3987	-0.3987	-0.3987	-0.5378	
0.975	*****	-0.2677	-0.3307	-0.4151	-0.4151	-0.4151	-0.4151	-0.4151	-0.5076	
1.000	0.0411	-0.1100	-0.2156	-0.3281	-0.3281	-0.3281	-0.3281	-0.3281	-0.3313	
	$C_{p,l}$	$C_{p,l}$	$C_{p,l}$	$C_{p,l}$	$C_{p,l}$	$C_{p,l}$	$C_{p,l}$	$C_{p,l}$	$C_{p,l}$	
-0.200	0.0664	0.0798	0.1546	*****	*****	*****	*****	*****	-0.6453	
-0.400	0.0514	0.0852	0.1196	-0.0353	-0.0353	-0.0353	-0.0353	-0.0353	-0.6847	
-0.600	0.0525	0.0762	0.1031	-0.0061	-0.0061	-0.0061	-0.0061	-0.0061	-0.6693	
-0.700	0.0670	0.0625	0.0933	0.0048	0.0048	0.0048	0.0048	0.0048	-0.6480	
-0.800	0.0985	*****	0.0812	0.0150	0.0150	0.0150	0.0150	0.0150	-0.6029	
-0.850	*****	0.0867	0.0806	0.0146	0.0146	0.0146	0.0146	0.0146	-0.6172	
-0.900	*****	0.1185	0.1005	0.0249	0.0249	0.0249	0.0249	0.0249	-0.6363	
-0.950	0.2046	0.1724	0.1562	0.0799	0.0799	0.0799	0.0799	0.0799	-0.2276	
-0.975	*****	0.2107	0.1970	0.1330	0.1330	0.1330	0.1330	0.1330	-0.0799	
-1.000	0.0312	-0.0988	-0.2816	-0.2678	-0.2678	-0.2678	-0.2678	-0.2678	-0.2533	

Medium Radius L.E.
 Run No. = 28 , Point No. = 557
 $C_N = 0.169$, $C_m = -0.0360$
 $\alpha = 3.9^\circ$, $M_\infty = 0.899$
 $R_{mac} = 60.0 \times 10^6$

Leading Edge Pressures

● starboard
 ○ port

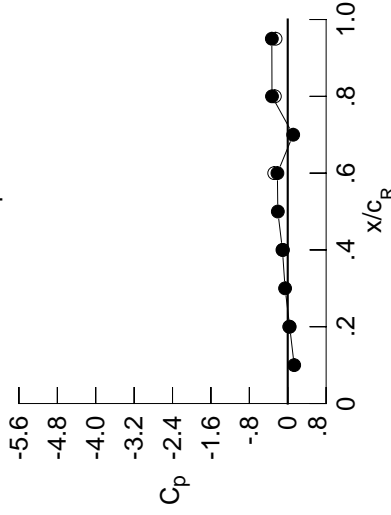

x/c_R	starb'd C_p	port C_p
0.10	0.1343	*****
0.20	0.0411	0.0312
0.30	-0.0553	*****
0.40	-0.1100	-0.0988
0.50	-0.2064	*****
0.60	-0.2156	-0.2816
0.70	0.1133	*****
0.80	-0.3281	-0.2678
0.90	*****	*****
0.95	-0.3313	-0.2533

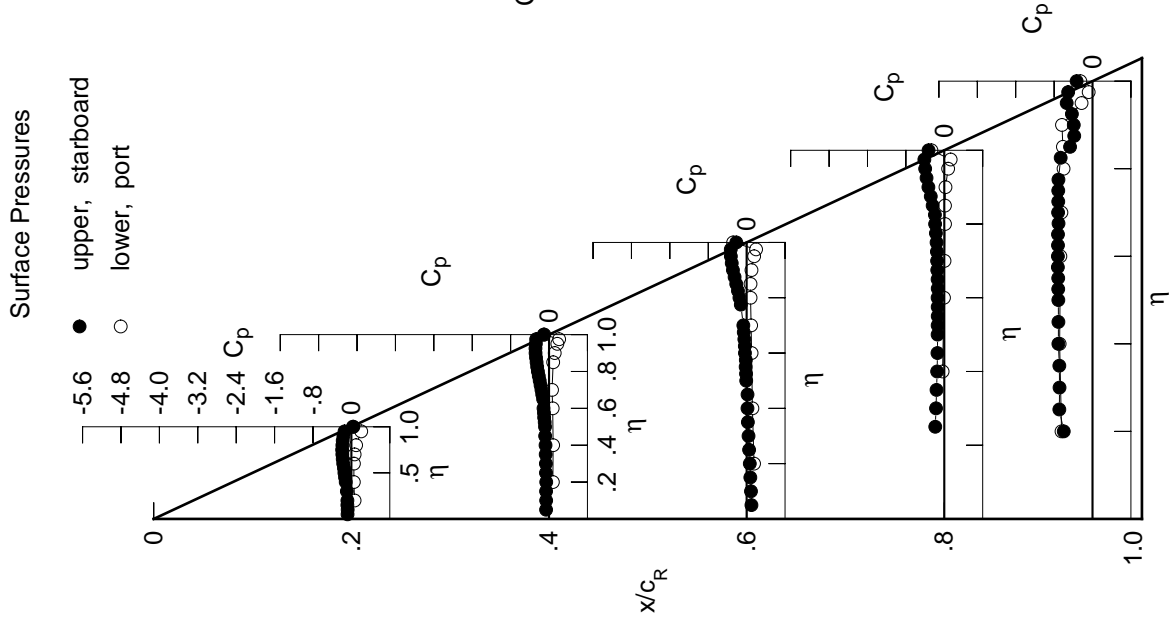

Table G4. Continued.

η	$x/c_R = .2$		$x/c_R = .4$		$x/c_R = .6$		$x/c_R = .8$		$x/c_R = .95$	
	$C_{p,u}$	$C_{p,u}$	$C_{p,u}$	$C_{p,u}$	$C_{p,u}$	$C_{p,u}$	$C_{p,u}$	$C_{p,u}$	$C_{p,u}$	$C_{p,u}$
0.050	-0.0992	-0.0787	0.0891	0.0891	0.0891	0.0891	0.0891	0.0891	0.0891	0.0891
0.100	-0.0973	-0.0783	0.0804	0.0804	0.0804	0.0804	0.0804	0.0804	0.0804	0.0804
0.150	-0.1027	-0.0796	0.0664	0.0664	0.0664	0.0664	0.0664	0.0664	0.0664	0.0664
0.200	-0.1036	-0.0768	0.0541	0.0541	0.0541	0.0541	0.0541	0.0541	0.0541	0.0541
0.250	*****	-0.0828	0.0397	0.0397	0.0397	0.0397	0.0397	0.0397	0.0397	0.0397
0.300	-0.1131	-0.0834	0.0266	0.0266	0.0266	0.0266	0.0266	0.0266	0.0266	0.0266
0.350	*****	-0.0902	0.0140	0.0140	0.0140	0.0140	0.0140	0.0140	0.0140	0.0140
0.400	-0.1399	-0.0930	0.0028	0.0028	0.0028	0.0028	0.0028	0.0028	0.0028	0.0028
0.450	-0.1554	-0.1030	0.0052	0.0052	0.0052	0.0052	0.0052	0.0052	0.0052	0.0052
0.500	-0.1707	-0.1058	0.0241	0.0241	0.0241	0.0241	0.0241	0.0241	0.0241	0.0241
0.525	*****	-0.1149	0.0292	0.0292	0.0292	0.0292	0.0292	0.0292	0.0292	0.0292
0.550	-0.1822	-0.1252	0.0385	0.0385	0.0385	0.0385	0.0385	0.0385	0.0385	0.0385
0.575	*****	-0.1318	0.0353	0.0353	0.0353	0.0353	0.0353	0.0353	0.0353	0.0353
0.600	-0.2007	-0.1419	0.0534	0.0534	0.0534	0.0534	0.0534	0.0534	0.0534	0.0534
0.625	*****	*****	-0.0575	-0.0575	-0.0575	-0.0575	-0.0575	-0.0575	-0.0575	-0.0575
0.650	-0.2149	-0.1522	0.0697	0.0697	0.0697	0.0697	0.0697	0.0697	0.0697	0.0697
0.675	*****	-0.1713	0.0826	0.0826	0.0826	0.0826	0.0826	0.0826	0.0826	0.0826
0.700	-0.2263	-0.1917	0.0929	0.0929	0.0929	0.0929	0.0929	0.0929	0.0929	0.0929
0.725	*****	-0.2122	*****	*****	*****	*****	*****	*****	*****	*****
0.750	-0.2357	-0.2338	*****	*****	*****	*****	*****	*****	*****	*****
0.775	*****	-0.2563	-0.1539	-0.1539	-0.2065	-0.2065	-0.2150	-0.2150	-0.2150	-0.2150
0.800	-0.2356	-0.2809	-0.1856	-0.1856	-0.2265	-0.2265	*****	*****	*****	*****
0.825	*****	-0.3008	-0.2243	-0.2243	-0.2332	-0.2332	-0.5955	-0.5955	-0.5955	-0.5955
0.850	-0.2349	-0.3203	-0.2666	-0.2666	-0.2854	-0.2854	-0.4015	-0.4015	-0.4015	-0.4015
0.875	*****	-0.3393	-0.3138	-0.3138	-0.3329	-0.3329	-0.3566	-0.3566	-0.3566	-0.3566
0.900	-0.2292	-0.3570	-0.3589	-0.3589	-0.3939	-0.3939	-0.3720	-0.3720	-0.3720	-0.3720
0.925	*****	-0.3701	-0.3987	-0.3987	-0.4517	-0.4517	-0.3939	-0.3939	-0.3939	-0.3939
0.950	-0.2173	-0.3745	-0.4358	-0.4358	-0.5058	-0.5058	-0.6115	-0.6115	-0.6115	-0.6115
0.975	*****	-0.3969	-0.4737	-0.4737	-0.5535	-0.5535	-0.6532	-0.6532	-0.6532	-0.6532
1.000	-0.0707	-0.3044	-0.5053	-0.5053	-0.6268	-0.6268	-0.5994	-0.5994	-0.5994	-0.5994
	$C_{p,l}$	$C_{p,l}$	$C_{p,l}$	$C_{p,l}$	$C_{p,l}$	$C_{p,l}$	$C_{p,l}$	$C_{p,l}$	$C_{p,l}$	$C_{p,l}$
-0.200	0.0893	0.0999	0.1696	0.1696	0.1696	0.1696	0.1696	0.1696	0.1696	0.1696
-0.400	0.0764	0.1055	0.1367	0.1367	0.1367	0.1367	0.1367	0.1367	0.1367	0.1367
-0.600	0.0818	0.1009	0.1224	0.1224	0.1224	0.1224	0.1224	0.1224	0.1224	0.1224
-0.700	0.0989	0.0901	0.1154	0.1154	0.1154	0.1154	0.1154	0.1154	0.1154	0.1154
-0.800	0.1319	*****	0.1083	0.1083	0.0383	0.0383	-0.5857	-0.5857	-0.5857	-0.5857
-0.850	*****	0.1213	0.1122	0.1122	0.0417	0.0417	-0.5954	-0.5954	-0.5954	-0.5954
-0.900	*****	0.1540	0.1343	0.1343	0.0574	0.0574	-0.6016	-0.6016	-0.6016	-0.6016
-0.950	0.2269	0.1999	0.1857	0.1857	0.1124	0.1124	-0.2102	-0.2102	-0.2102	-0.2102
-0.975	*****	0.2235	0.2132	0.2132	0.1544	0.1544	-0.0646	-0.0646	-0.0646	-0.0646
-1.000	-0.0786	-0.2837	-0.5344	-0.5344	-0.5681	-0.5681	-0.5037	-0.5037	-0.5037	-0.5037

Medium Radius L.E.
 Run No. = 28 , Point No. = 558
 $C_N = 0.215$, $C_m = -0.0443$
 $\alpha = 5.0^\circ$, $M_\infty = 0.901$
 $R_{mac} = 59.9 \times 10^6$

Leading Edge Pressures

● starboard
 ○ port

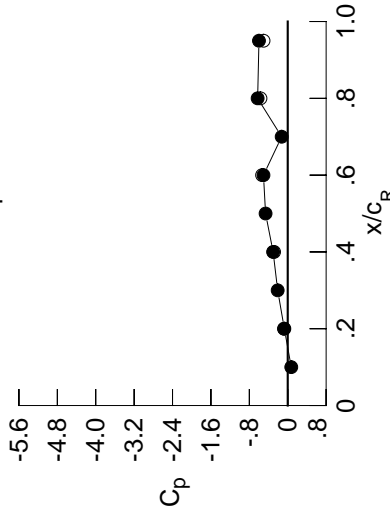

x/c_R	starb'd C_p	port C_p
0.10	0.0733	*****
0.20	-0.0707	-0.0786
0.30	-0.2094	*****
0.40	-0.3044	-0.2837
0.50	-0.4618	*****
0.60	-0.5053	-0.5344
0.70	-0.1266	*****
0.80	-0.6268	-0.5681
0.90	*****	*****
0.95	-0.5994	-0.5037

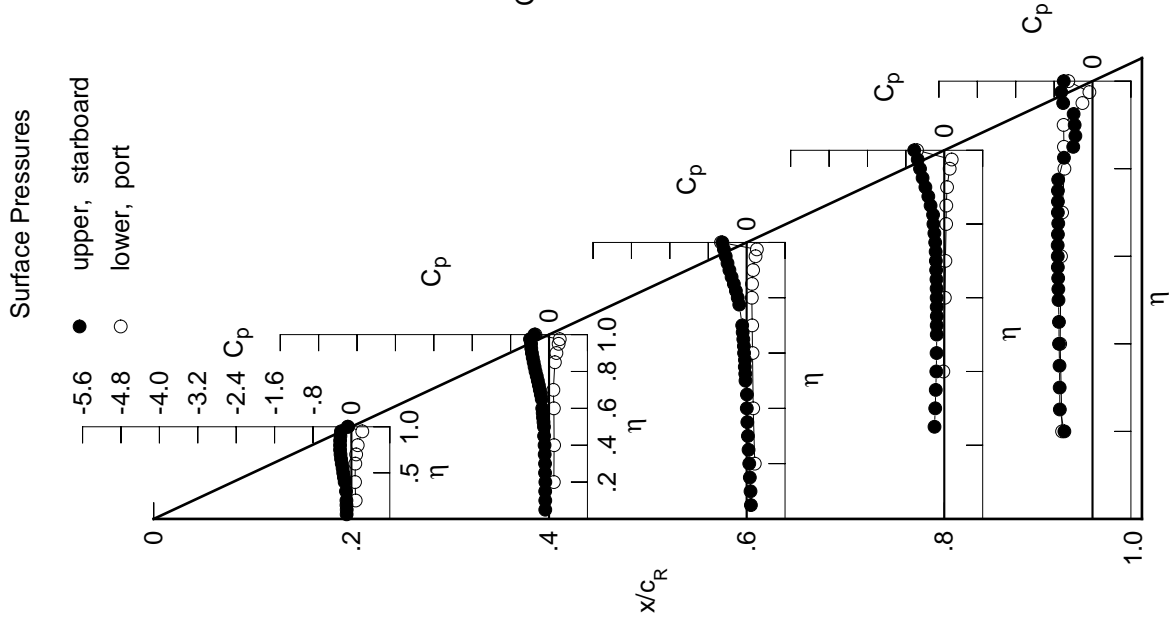
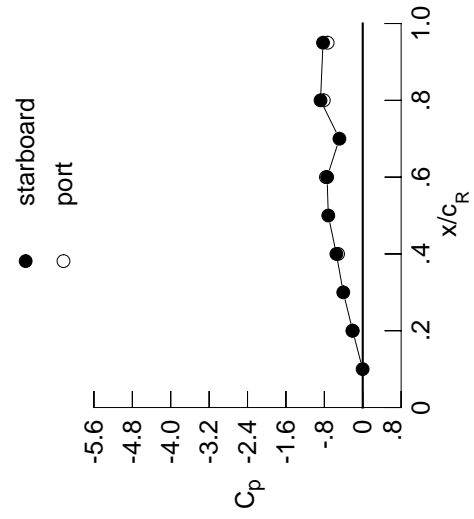

Table G4. Continued.

η	$x/c_R = .2$		$x/c_R = .4$		$x/c_R = .6$		$x/c_R = .8$		$x/c_R = .95$	
	$C_{p,u}$	$C_{p,u}$	$C_{p,u}$	$C_{p,u}$	$C_{p,u}$	$C_{p,u}$	$C_{p,u}$	$C_{p,u}$	$C_{p,u}$	$C_{p,u}$
0.050	-0.1173	-0.0961	0.0777	*****	*****	*****	*****	*****	*****	*****
0.100	-0.1161	-0.0958	0.0687	*****	*****	*****	*****	*****	*****	*****
0.150	-0.1221	-0.0983	0.0547	*****	*****	*****	*****	*****	*****	*****
0.200	-0.1228	-0.0954	0.0421	*****	*****	*****	*****	*****	*****	*****
0.250	*****	-0.1020	0.0265	-0.2189	-0.6608	*****	*****	*****	*****	*****
0.300	-0.1335	-0.1037	0.0136	-0.2040	-0.6534	*****	*****	*****	*****	*****
0.350	*****	-0.1103	-0.0005	-0.1941	-0.6429	*****	*****	*****	*****	*****
0.400	-0.1628	-0.1144	-0.0124	-0.1823	-0.6532	*****	*****	*****	*****	*****
0.450	-0.1793	-0.1247	-0.0102	-0.1782	-0.6557	*****	*****	*****	*****	*****
0.500	-0.1968	-0.1296	-0.0410	-0.1744	-0.6891	*****	*****	*****	*****	*****
0.525	*****	-0.1394	-0.0466	-0.1760	-0.7108	*****	*****	*****	*****	*****
0.550	-0.2110	-0.1518	-0.0564	-0.1743	-0.7198	*****	*****	*****	*****	*****
0.575	*****	-0.1580	-0.0546	-0.1775	-0.7286	*****	*****	*****	*****	*****
0.600	-0.2323	-0.1693	-0.0744	-0.1798	-0.7306	*****	*****	*****	*****	*****
0.625	*****	*****	-0.0786	-0.1800	-0.7336	*****	*****	*****	*****	*****
0.650	-0.2502	-0.1821	-0.0923	-0.1849	-0.7408	*****	*****	*****	*****	*****
0.675	*****	-0.2038	-0.1071	-0.1937	-0.7237	*****	*****	*****	*****	*****
0.700	-0.2666	-0.2257	-0.1194	-0.2004	-0.7306	*****	*****	*****	*****	*****
0.725	*****	-0.2486	*****	-0.2096	-0.7326	*****	*****	*****	*****	*****
0.750	-0.2814	-0.2749	*****	-0.2236	-0.7293	*****	*****	*****	*****	*****
0.775	*****	-0.3020	-0.1891	-0.2442	-0.6796	*****	*****	*****	*****	*****
0.800	-0.2880	-0.3312	-0.2249	-0.2653	*****	*****	*****	*****	*****	*****
0.825	*****	-0.3581	-0.2673	-0.2752	-0.5227	*****	*****	*****	*****	*****
0.850	-0.2925	-0.3856	-0.3160	-0.3250	-0.3695	*****	*****	*****	*****	*****
0.875	*****	-0.4137	-0.3722	-0.3805	-0.3494	*****	*****	*****	*****	*****
0.900	-0.2948	-0.4408	-0.4301	-0.4540	-0.3702	*****	*****	*****	*****	*****
0.925	*****	-0.4673	-0.4885	-0.5284	-0.3763	*****	*****	*****	*****	*****
0.950	-0.3031	-0.4861	-0.5507	-0.6040	-0.7129	*****	*****	*****	*****	*****
0.975	*****	-0.5390	-0.6271	-0.6907	-0.7964	*****	*****	*****	*****	*****
1.000	-0.2087	-0.5491	-0.7422	-0.8792	-0.8274	*****	*****	*****	*****	*****
-0.200	$C_{p,l}$	$C_{p,l}$	$C_{p,l}$	$C_{p,l}$	$C_{p,l}$	$C_{p,l}$	$C_{p,l}$	$C_{p,l}$	$C_{p,l}$	$C_{p,l}$
-0.400	0.1123	0.1202	0.1836	*****	*****	*****	*****	*****	*****	*****
-0.600	0.1013	0.1262	0.1522	-0.0053	-0.6693	*****	*****	*****	*****	*****
-0.700	0.1103	0.1238	0.1393	0.0269	-0.6511	*****	*****	*****	*****	*****
-0.800	0.1290	0.1162	0.1351	0.0411	-0.6263	*****	*****	*****	*****	*****
-0.850	0.1623	*****	0.1326	0.0577	-0.5750	*****	*****	*****	*****	*****
-0.900	*****	0.1524	0.1395	0.0654	-0.5806	*****	*****	*****	*****	*****
-0.950	0.2426	0.1837	0.1627	0.0852	-0.5776	*****	*****	*****	*****	*****
-0.975	0.2426	0.2202	0.2064	0.1365	-0.2016	*****	*****	*****	*****	*****
-1.000	-0.2155	-0.5138	-0.7672	-0.8115	-0.7312	*****	*****	*****	*****	*****

Medium Radius L.E.
 Run No. = 28 , Point No. = 559
 $C_N = 0.262$, $C_m = -0.0531$
 $\alpha = 6.0^\circ$, $M_\infty = 0.900$
 $R_{mac} = 59.9 \times 10^6$

Leading Edge Pressures



x/c_R	starb'd C_p	port C_p
0.10	-0.0023	*****
0.20	-0.2087	-0.2155
0.30	-0.4058	*****
0.40	-0.5491	-0.5138
0.50	-0.7175	*****
0.60	-0.7422	-0.7672
0.70	-0.4857	*****
0.80	-0.8792	-0.8115
0.90	*****	*****
0.95	-0.8274	-0.7312

Surface Pressures

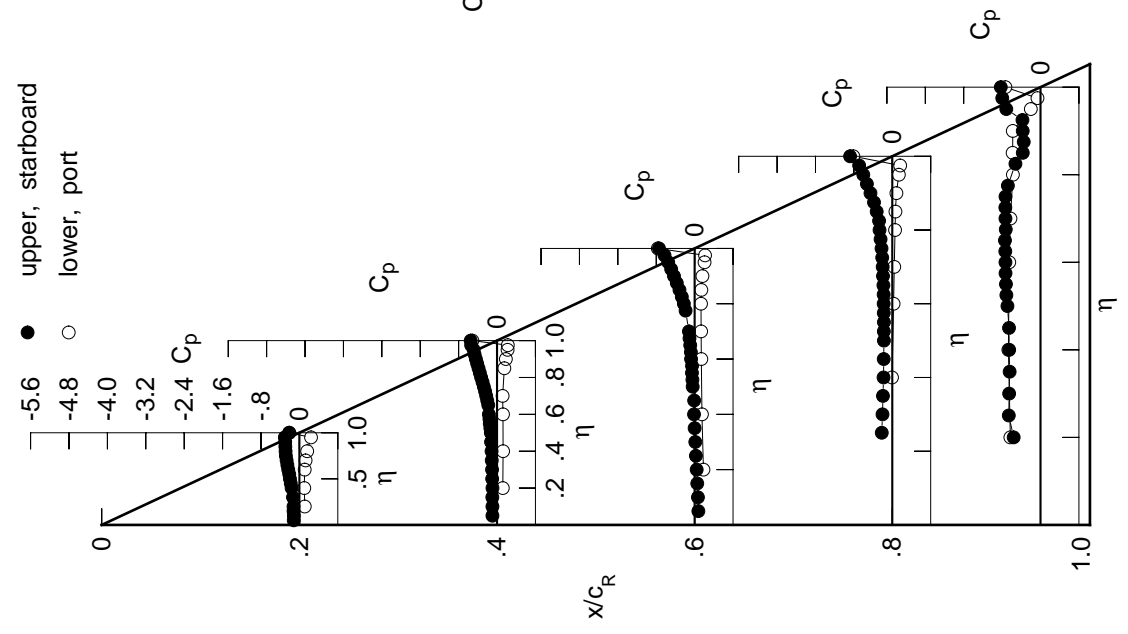

Table G4. Continued.

η	$x/c_R = .2$		$x/c_R = .4$		$x/c_R = .6$		$x/c_R = .8$		$x/c_R = .95$	
	$C_{p,u}$	$C_{p,l}$	$C_{p,u}$	$C_{p,l}$	$C_{p,u}$	$C_{p,l}$	$C_{p,u}$	$C_{p,l}$	$C_{p,u}$	$C_{p,l}$
0.050	-0.1346	-0.1141	0.0650	*****	*****	*****	*****	*****	*****	*****
0.100	-0.1350	-0.1147	0.0563	*****	*****	*****	*****	*****	*****	*****
0.150	-0.1406	-0.1164	0.0418	*****	*****	*****	*****	*****	*****	*****
0.200	-0.1426	-0.1147	0.0288	*****	*****	*****	*****	*****	*****	*****
0.250	*****	-0.1218	0.0125	-0.2333	-0.6343	*****	*****	*****	*****	-0.5534
0.300	-0.1536	-0.1234	0.0002	-0.2192	-0.6243	*****	*****	*****	*****	*****
0.350	*****	-0.1316	-0.0150	-0.2084	-0.6013	*****	*****	*****	*****	*****
0.400	-0.1847	-0.1355	-0.0270	-0.1980	-0.6232	*****	*****	*****	*****	*****
0.450	-0.2030	-0.1485	-0.0273	-0.1934	-0.6886	*****	*****	*****	*****	*****
0.500	-0.2224	-0.1540	-0.0578	-0.1904	-0.7156	*****	*****	*****	*****	*****
0.525	*****	-0.1650	-0.0645	-0.1918	-0.7215	*****	*****	*****	*****	*****
0.550	-0.2384	-0.1781	-0.0749	-0.1923	-0.7169	*****	*****	*****	*****	*****
0.575	*****	-0.1853	-0.0741	-0.1978	-0.7169	*****	*****	*****	*****	*****
0.600	-0.2631	-0.1979	-0.0963	-0.2037	-0.7137	*****	*****	*****	*****	*****
0.625	*****	*****	-0.1029	-0.2083	-0.7086	*****	*****	*****	*****	*****
0.650	-0.2844	-0.2142	-0.1196	-0.2157	-0.7079	*****	*****	*****	*****	*****
0.675	*****	-0.2375	-0.1373	-0.2258	-0.6955	*****	*****	*****	*****	*****
0.700	-0.3059	-0.2615	-0.1530	-0.2370	-0.6993	*****	*****	*****	*****	*****
0.725	*****	-0.2873	*****	-0.2473	-0.6945	*****	*****	*****	*****	*****
0.750	-0.3232	-0.3172	*****	-0.2608	-0.6810	*****	*****	*****	*****	*****
0.775	*****	-0.3475	-0.2219	-0.2793	-0.6608	*****	*****	*****	*****	*****
0.800	-0.3399	-0.3834	-0.2574	-0.3003	*****	*****	*****	*****	*****	*****
0.825	*****	-0.4178	-0.3019	-0.3140	-0.5789	*****	*****	*****	*****	*****
0.850	-0.3602	-0.4518	-0.3550	-0.3607	-0.5050	*****	*****	*****	*****	*****
0.875	*****	-0.4882	-0.4198	-0.4070	-0.4680	*****	*****	*****	*****	*****
0.900	-0.3701	-0.5257	-0.4918	-0.4864	-0.4745	*****	*****	*****	*****	*****
0.925	*****	-0.5685	-0.5641	-0.5673	-0.5129	*****	*****	*****	*****	*****
0.950	-0.3980	-0.6021	-0.6295	-0.6548	-0.5628	*****	*****	*****	*****	*****
0.975	*****	-0.6850	-0.8583	-0.9458	-0.6234	*****	*****	*****	*****	*****
1.000	-0.3672	-0.7648	-0.8901	-1.0474	-0.8818	*****	*****	*****	*****	*****
-0.200	$C_{p,l}$	0.1344	0.1382	0.1970	*****	*****	*****	*****	*****	-0.6198
-0.400		0.1251	0.1461	0.1663	0.0080	-0.6614	*****	*****	*****	*****
-0.600		0.1365	0.1449	0.1551	0.0411	-0.6405	*****	*****	*****	*****
-0.700		0.1565	0.1411	0.1534	0.0564	-0.6169	*****	*****	*****	*****
-0.800		0.1888	*****	0.1537	0.0756	-0.5610	*****	*****	*****	*****
-0.850		*****	0.1794	0.1625	0.0857	-0.5635	*****	*****	*****	*****
-0.900		*****	0.2083	0.1853	0.1077	-0.5514	*****	*****	*****	*****
-0.950		0.2507	0.2329	0.2187	0.1531	-0.1861	*****	*****	*****	*****
-0.975		*****	0.2181	0.2116	0.1655	-0.0487	*****	*****	*****	*****
-1.000		-0.3790	-0.7193	-0.9235	-0.9672	-0.7854	*****	*****	*****	*****

Medium Radius L.E.

Run No. = 28 , Point No. = 560

$C_N = 0.310$, $C_m = -0.0623$

$\alpha = 7.1^\circ$, $M_\infty = 0.901$

$R_{mac} = 59.8 \times 10^6$

Leading Edge Pressures

● starboard
○ port

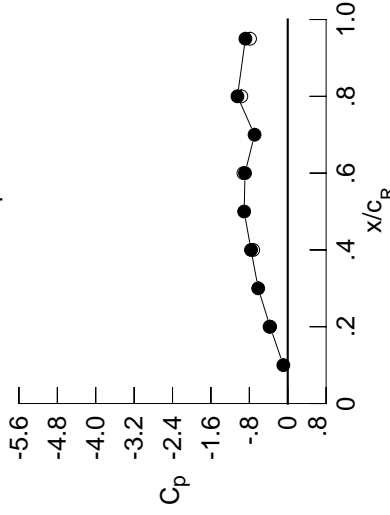

Surface Pressures

● upper, starboard
○ lower, port

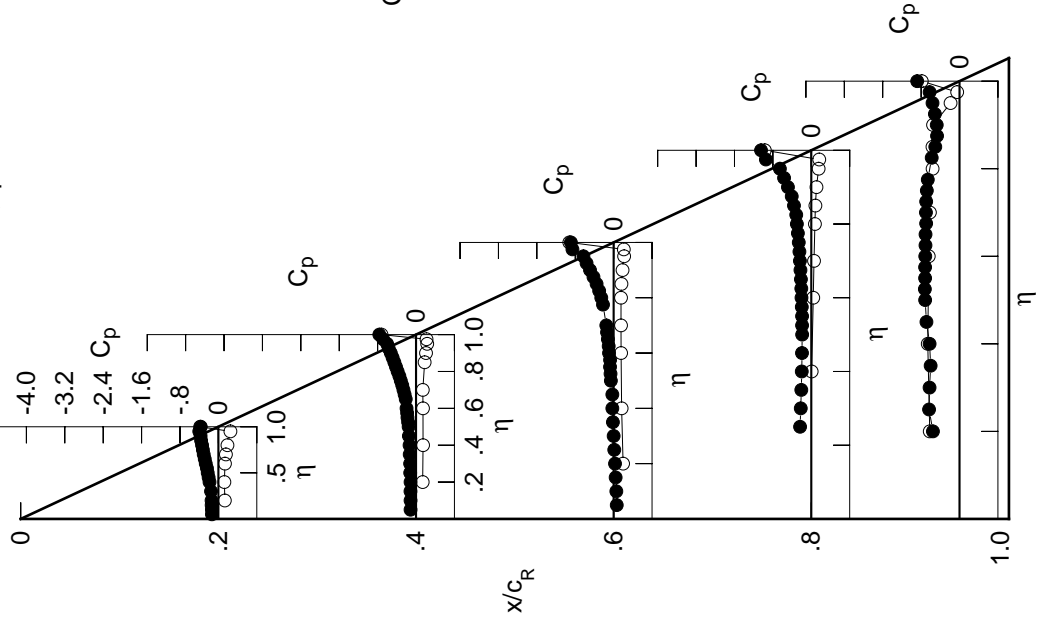
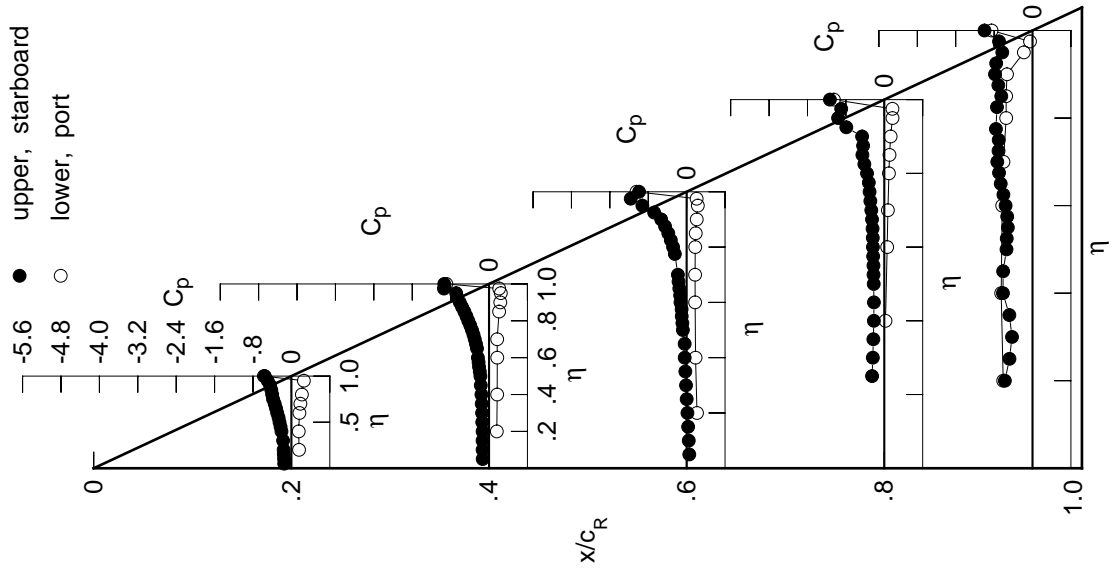

Table G4. Continued.

η	x/c_R .2	x/c_R .4	x/c_R .6	x/c_R .8	x/c_R .95
	$C_{p,u}$	$C_{p,u}$	$C_{p,u}$	$C_{p,u}$	$C_{p,u}$
0.050	-0.1494	-0.1327	0.0552	*****	*****
0.100	-0.1523	-0.1342	0.0441	*****	*****
0.150	-0.1582	-0.1352	0.0314	*****	*****
0.200	-0.1618	-0.1348	0.0165	*****	-0.5761
0.250	*****	-0.1414	0.0006	-0.2540	-0.4796
0.300	-0.1729	-0.1449	-0.0129	-0.2386	-0.4272
0.350	*****	-0.1527	-0.0270	-0.2281	-0.4825
0.400	-0.2068	-0.1586	-0.0405	-0.2168	-0.6156
0.450	-0.2259	-0.1719	-0.0416	-0.2163	-0.6116
0.500	-0.2476	-0.1798	-0.0780	-0.2203	-0.5419
0.525	*****	-0.1926	-0.0885	-0.2237	-0.5369
0.550	-0.2672	-0.2078	-0.1020	-0.2255	-0.5134
0.575	*****	-0.2177	-0.1049	-0.2317	-0.5275
0.600	-0.2952	-0.2322	-0.1284	-0.2372	-0.5607
0.625	*****	*****	-0.1352	-0.2391	-0.6063
0.650	-0.3200	-0.2503	-0.1529	-0.2440	-0.6621
0.675	*****	-0.2730	-0.1688	-0.2554	-0.6975
0.700	-0.3477	-0.2979	-0.1826	-0.2702	-0.7334
0.725	*****	-0.3238	*****	-0.2901	-0.7077
0.750	-0.3826	-0.3559	*****	-0.3068	-0.7038
0.775	*****	-0.3911	-0.2458	-0.3221	-0.7620
0.800	-0.3999	-0.4322	-0.2826	-0.3600	*****
0.825	*****	-0.4715	-0.3295	-0.4155	-0.7401
0.850	-0.4181	-0.5138	-0.3827	-0.4558	-0.6503
0.875	*****	-0.5623	-0.4496	-0.4418	-0.7118
0.900	-0.4442	-0.6094	-0.5306	-0.4621	-0.7812
0.925	*****	-0.6586	-0.6771	-0.7910	-0.7570
0.950	-0.4947	-0.6848	-0.9225	-0.9626	-0.6292
0.975	*****	-0.9395	-1.1647	-0.8975	-0.6973
1.000	-0.5541	-0.9330	-0.9914	-1.1330	-0.9996
	$C_{p,l}$	$C_{p,l}$	$C_{p,l}$	$C_{p,l}$	$C_{p,l}$
-0.200	0.1593	0.1614	0.2158	*****	-0.6104
-0.400	0.1530	0.1700	0.1855	0.0254	-0.6526
-0.600	0.1670	0.1715	0.1768	0.0599	-0.6309
-0.700	0.1875	0.1694	0.1760	0.0755	-0.6059
-0.800	0.2186	*****	0.1790	0.0967	-0.5486
-0.850	*****	0.2097	0.1893	0.1090	-0.5495
-0.900	*****	0.2342	0.2103	0.1319	-0.5313
-0.950	0.2601	0.2460	0.2332	0.1710	-0.1796
-0.975	*****	0.2109	0.2077	0.1696	-0.0520
-1.000	-0.5734	-0.8890	-1.0456	-1.0496	-0.8525

Surface Pressures



Medium Radius L.E.
 Run No. = 28, Point No. = 561
 $C_N = 0.367$, $C_m = -0.0763$
 $\alpha = 8.1^\circ$, $M_\infty = 0.899$
 $R_{mac} = 59.8 \times 10^6$

Leading Edge Pressures

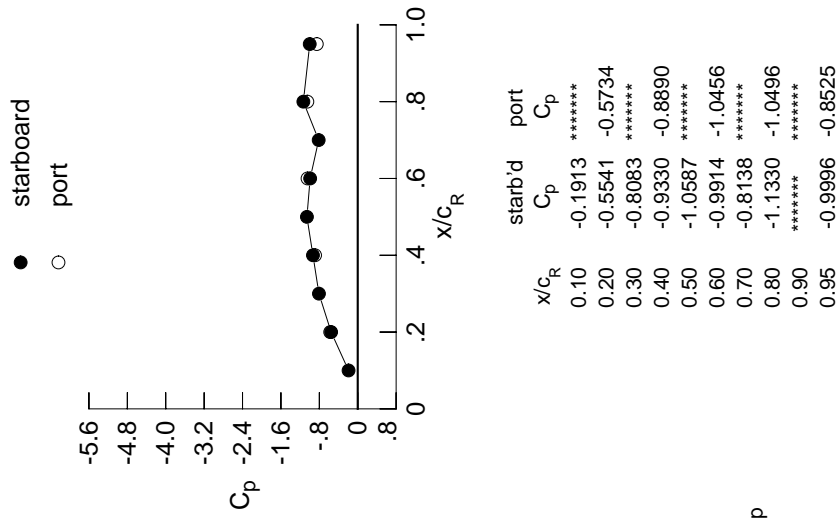

Table G4. Continued.

η	$x/c_R = .2$		$x/c_R = .4$		$x/c_R = .6$		$x/c_R = .8$		$x/c_R = .95$	
	$C_{p,u}$	$C_{p,u}$	$C_{p,u}$	$C_{p,u}$	$C_{p,u}$	$C_{p,u}$	$C_{p,u}$	$C_{p,u}$	$C_{p,u}$	$C_{p,u}$
0.050	-0.1638	-0.1504	0.0395	*****	*****	*****	*****	*****	*****	*****
0.100	-0.1683	-0.1527	0.0288	*****	*****	*****	*****	*****	*****	*****
0.150	-0.1762	-0.1542	0.0142	*****	*****	*****	*****	*****	*****	*****
0.200	-0.1795	-0.1539	0.0002	*****	*****	*****	*****	*****	*****	-0.4300
0.250	*****	-0.1619	-0.0168	-0.2773	-0.3108	*****	*****	*****	*****	-0.3108
0.300	-0.1925	-0.1653	-0.0287	-0.2602	-0.4154	*****	*****	*****	*****	-0.4154
0.350	*****	-0.1739	-0.0427	-0.2486	-0.5998	*****	*****	*****	*****	-0.5998
0.400	-0.2275	-0.1806	-0.0613	-0.2448	-0.5561	*****	*****	*****	*****	-0.5561
0.450	-0.2489	-0.1955	-0.0733	-0.2486	-0.4489	*****	*****	*****	*****	-0.4489
0.500	-0.2723	-0.2106	-0.1106	-0.2505	-0.4111	*****	*****	*****	*****	-0.4111
0.525	*****	-0.2263	-0.1216	-0.2508	-0.4310	*****	*****	*****	*****	-0.4310
0.550	-0.2948	-0.2428	-0.1356	-0.2524	-0.4452	*****	*****	*****	*****	-0.4452
0.575	*****	-0.2548	-0.1397	-0.2600	-0.5147	*****	*****	*****	*****	-0.5147
0.600	-0.3264	-0.2676	-0.1611	-0.2656	-0.6374	*****	*****	*****	*****	-0.6374
0.625	*****	*****	-0.1616	-0.2592	-0.7477	*****	*****	*****	*****	-0.7477
0.650	-0.3619	-0.2834	-0.1758	-0.2578	-0.8181	*****	*****	*****	*****	-0.8181
0.675	*****	-0.3043	-0.1937	-0.2748	-0.8593	*****	*****	*****	*****	-0.8593
0.700	-0.3973	-0.3278	-0.2086	-0.3292	-0.8846	*****	*****	*****	*****	-0.8846
0.725	*****	-0.3552	*****	-0.4186	-0.8374	*****	*****	*****	*****	-0.8374
0.750	-0.4263	-0.3884	*****	-0.4648	-0.7569	*****	*****	*****	*****	-0.7569
0.775	*****	-0.4244	-0.2805	-0.5074	-0.7021	*****	*****	*****	*****	-0.7021
0.800	-0.4519	-0.4679	-0.3110	-0.5682	*****	*****	*****	*****	*****	-0.5682
0.825	*****	-0.5116	-0.3369	-0.6177	-0.6207	*****	*****	*****	*****	-0.6207
0.850	-0.4851	-0.5571	-0.4947	-0.5674	-0.5822	*****	*****	*****	*****	-0.5822
0.875	*****	-0.6043	-0.8297	-0.5212	-0.6384	*****	*****	*****	*****	-0.6384
0.900	-0.5253	-0.6470	-0.9368	-0.5458	-0.8489	*****	*****	*****	*****	-0.8489
0.925	*****	-0.7205	-0.9103	-0.8606	-0.8824	*****	*****	*****	*****	-0.8824
0.950	-0.6036	-1.0091	-0.8183	-0.8768	-0.6947	*****	*****	*****	*****	-0.6947
0.975	*****	-1.4511	-1.2235	-0.7549	-0.8053	*****	*****	*****	*****	-0.8053
1.000	-0.7092	-1.0489	-1.0482	-1.1872	-1.0778	*****	*****	*****	*****	-1.0778
-0.200	$C_{p,l}$	0.1866	0.1847	0.2325	*****	*****	*****	*****	*****	-0.5992
-0.400	$C_{p,l}$	0.1803	0.1931	0.2037	0.0423	-0.6435	*****	*****	*****	-0.6435
-0.600	$C_{p,l}$	0.1964	0.1956	0.1948	0.0766	-0.6200	*****	*****	*****	-0.6200
-0.700	$C_{p,l}$	0.2174	0.1958	0.1966	0.0935	-0.5954	*****	*****	*****	-0.5954
-0.800	$C_{p,l}$	0.2458	*****	0.2013	0.1152	-0.5360	*****	*****	*****	-0.5360
-0.850	$C_{p,l}$	*****	0.2358	0.2118	0.1290	-0.5365	*****	*****	*****	-0.5365
-0.900	$C_{p,l}$	*****	0.2557	0.2307	0.1521	-0.5164	*****	*****	*****	-0.5164
-0.950	$C_{p,l}$	0.2640	0.2541	0.2428	0.1838	-0.1799	*****	*****	*****	-0.1799
-0.975	$C_{p,l}$	*****	0.2009	0.2025	0.1702	-0.0654	*****	*****	*****	-0.0654
-1.000	$C_{p,l}$	-0.7431	-0.9977	-1.1066	-1.0850	-0.9456	*****	*****	*****	-0.9456

Medium Radius L.E.
 Run No. = 28 , Point No. = 562
 $C_N = 0.425$, $C_m = -0.0890$
 $\alpha = 9.1^\circ$, $M_\infty = 0.899$
 $R_{mac} = 59.8 \times 10^6$

Leading Edge Pressures

● starboard
 ○ port

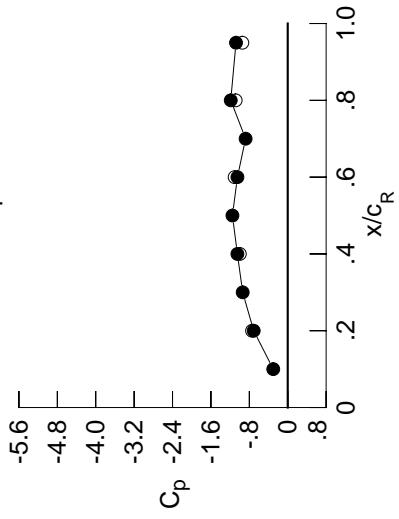

x/c_R	starb'd C_p	port C_p
0.10	-0.3013	*****
0.20	-0.7092	-0.7431
0.30	-0.9384	*****
0.40	-1.0489	-0.9977
0.50	-1.1518	*****
0.60	-1.0482	-1.1066
0.70	-0.8780	*****
0.80	-1.1872	-1.0850
0.90	*****	*****
0.95	-1.0778	-0.9456

Surface Pressures

● upper, starboard
 ○ lower, port

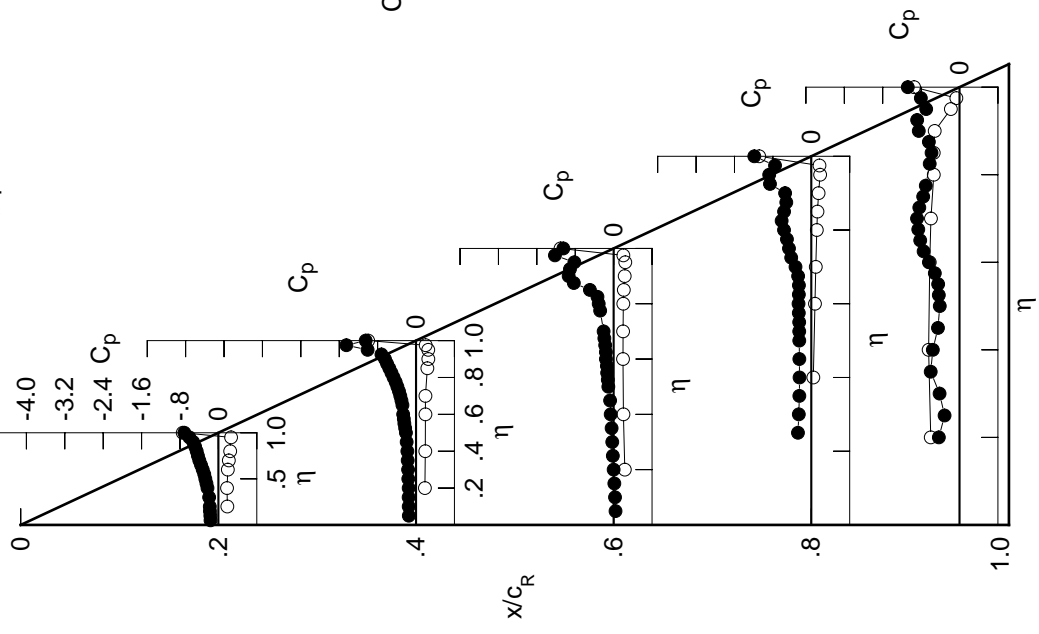
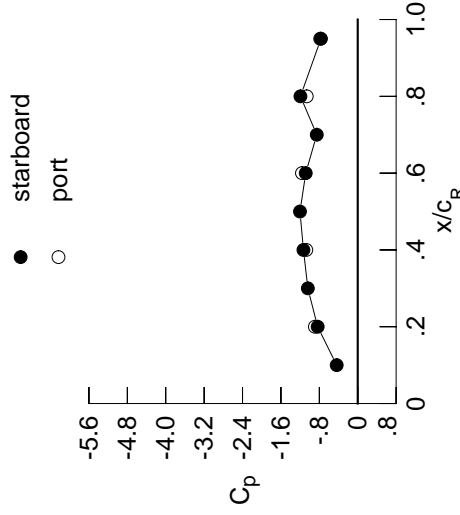

Table G4. Continued.

η	$x/c_R = .2$		$x/c_R = .4$		$x/c_R = .6$		$x/c_R = .8$		$x/c_R = .95$	
	$C_{p,u}$	$C_{p,u}$	$C_{p,u}$	$C_{p,u}$	$C_{p,u}$	$C_{p,u}$	$C_{p,u}$	$C_{p,u}$	$C_{p,l}$	$C_{p,l}$
0.050	-0.1777	-0.1677	0.0181	*****	*****	*****	*****	*****	*****	*****
0.100	-0.1856	-0.1718	0.0075	*****	*****	*****	*****	*****	*****	*****
0.150	-0.1943	-0.1723	-0.0078	*****	*****	*****	*****	*****	*****	*****
0.200	-0.1992	-0.1736	-0.0226	*****	*****	*****	*****	*****	*****	-0.2890
0.250	*****	-0.1808	-0.0367	-0.2992	-0.2992	-0.3279	-0.3279	-0.3279	-0.3279	-0.3279
0.300	-0.2138	-0.1840	-0.0507	-0.2826	-0.2826	-0.5288	-0.5288	-0.5288	-0.5288	-0.5288
0.350	*****	-0.1919	-0.0753	-0.2762	-0.2762	-0.5423	-0.5423	-0.5423	-0.5423	-0.5423
0.400	-0.2500	-0.2049	-0.1012	-0.2667	-0.2667	-0.4495	-0.4495	-0.4495	-0.4495	-0.4495
0.450	-0.2735	-0.2303	-0.1136	-0.2635	-0.2635	-0.4458	-0.4458	-0.4458	-0.4458	-0.4458
0.500	-0.2995	-0.2450	-0.1464	-0.2618	-0.2618	-0.5215	-0.5215	-0.5215	-0.5215	-0.5215
0.525	*****	-0.2589	-0.1576	-0.2675	-0.2675	-0.6038	-0.6038	-0.6038	-0.6038	-0.6038
0.550	-0.3272	-0.2727	-0.1716	-0.2759	-0.2759	-0.6492	-0.6492	-0.6492	-0.6492	-0.6492
0.575	*****	-0.2815	-0.1730	-0.2906	-0.2906	-0.7024	-0.7024	-0.7024	-0.7024	-0.7024
0.600	-0.3634	-0.2929	-0.2029	-0.3057	-0.3057	-0.7460	-0.7460	-0.7460	-0.7460	-0.7460
0.625	*****	*****	-0.2135	-0.3172	-0.3172	-0.7937	-0.7937	-0.7937	-0.7937	-0.7937
0.650	-0.3994	-0.3077	-0.2438	-0.3376	-0.3376	-0.8598	-0.8598	-0.8598	-0.8598	-0.8598
0.675	*****	-0.3274	-0.2842	-0.3757	-0.3757	-0.9078	-0.9078	-0.9078	-0.9078	-0.9078
0.700	-0.4371	-0.3494	-0.3239	-0.4390	-0.4390	-0.9096	-0.9096	-0.9096	-0.9096	-0.9096
0.725	*****	-0.3796	*****	-0.5431	-0.5431	-0.8173	-0.8173	-0.8173	-0.8173	-0.8173
0.750	-0.4737	-0.4170	*****	-0.6489	-0.6489	-0.7234	-0.7234	-0.7234	-0.7234	-0.7234
0.775	*****	-0.4566	-0.4445	-0.7361	-0.7361	-0.6651	-0.6651	-0.6651	-0.6651	-0.6651
0.800	-0.5081	-0.4979	-0.5331	-0.7636	-0.7636	*****	*****	*****	*****	*****
0.825	*****	-0.5407	-0.5635	-0.7666	-0.7666	-0.6314	-0.6314	-0.6314	-0.6314	-0.6314
0.850	-0.5508	-0.6008	-0.6018	-0.6951	-0.6951	-0.6275	-0.6275	-0.6275	-0.6275	-0.6275
0.875	*****	-0.7110	-0.8088	-0.6221	-0.6418	-0.6418	-0.6418	-0.6418	-0.6418	-0.6418
0.900	-0.6049	-0.8953	-1.0377	-0.6029	-0.6590	-0.6590	-0.6590	-0.6590	-0.6590	-0.6590
0.925	*****	-1.0882	-1.0468	-0.7137	-0.5935	-0.5935	-0.5935	-0.5935	-0.5935	-0.5935
0.950	-0.6880	-1.2181	-1.0037	-0.9221	-0.5112	-0.5112	-0.5112	-0.5112	-0.5112	-0.5112
0.975	*****	-1.3182	-0.9782	-0.7256	-0.5254	-0.5254	-0.5254	-0.5254	-0.5254	-0.5254
1.000	-0.8347	-1.1308	-1.0830	-1.1933	-0.7663	-0.7663	-0.7663	-0.7663	-0.7663	-0.7663
-0.200	$C_{p,l}$	$C_{p,l}$	$C_{p,l}$	$C_{p,l}$	$C_{p,l}$	$C_{p,l}$	$C_{p,l}$	$C_{p,l}$	$C_{p,l}$	$C_{p,l}$
-0.400	0.2147	0.2097	0.2509	*****	*****	-0.5893	-0.5893	-0.5893	-0.5893	-0.5893
-0.600	0.2098	0.2189	0.2226	0.0590	0.0590	-0.6337	-0.6337	-0.6337	-0.6337	-0.6337
-0.700	0.2282	0.2221	0.2160	0.0936	-0.6101	-0.6101	-0.6101	-0.6101	-0.6101	-0.6101
-0.800	0.2481	0.2237	0.2175	0.1100	-0.5843	-0.5843	-0.5843	-0.5843	-0.5843	-0.5843
-0.850	0.2739	*****	0.2233	0.1333	-0.5249	-0.5249	-0.5249	-0.5249	-0.5249	-0.5249
-0.900	*****	0.2617	0.2330	0.1468	-0.5246	-0.5246	-0.5246	-0.5246	-0.5246	-0.5246
-0.950	*****	0.2770	0.2494	0.1681	-0.5009	-0.5009	-0.5009	-0.5009	-0.5009	-0.5009
-0.975	0.2662	0.2618	0.2499	0.1924	-0.1713	-0.1713	-0.1713	-0.1713	-0.1713	-0.1713
-1.000	*****	0.1907	0.1942	0.1679	-0.0576	-0.0576	-0.0576	-0.0576	-0.0576	-0.0576
-1.000	-0.8929	-1.0715	-1.1624	-1.0623	-0.7816	-0.7816	-0.7816	-0.7816	-0.7816	-0.7816

Medium Radius L.E.
 Run No. = 28 , Point No. = 563
 $C_N = 0.485$, $C_m = -0.1007$
 $\alpha = 10.2^\circ$, $M_\infty = 0.900$
 $R_{mac} = 59.7 \times 10^6$

Leading Edge Pressures



x/c_R	starb'd C_p	port C_p
0.10	-0.4381	*****
0.20	-0.8347	-0.8929
0.30	-1.0391	*****
0.40	-1.1308	-1.0715
0.50	-1.2030	*****
0.60	-1.0830	-1.1624
0.70	-0.8535	*****
0.80	-1.1933	-1.0623
0.90	*****	*****
0.95	-0.7663	-0.7816

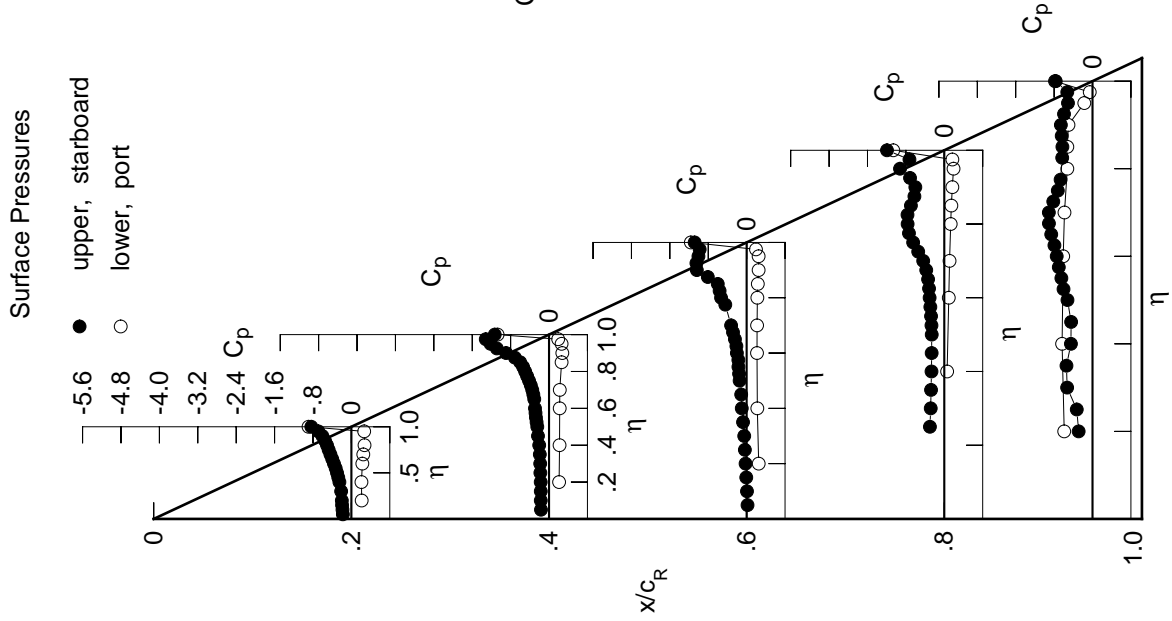

Table G4. Continued.

η	$x/c_R = .2$		$x/c_R = .4$		$x/c_R = .6$		$x/c_R = .8$		$x/c_R = .95$	
	$C_{p,u}$	$C_{p,u}$	$C_{p,u}$	$C_{p,u}$	$C_{p,u}$	$C_{p,u}$	$C_{p,u}$	$C_{p,u}$	$C_{p,u}$	$C_{p,u}$
0.050	-0.1910	-0.2030	-0.0057	*****	*****	*****	*****	*****	*****	*****
0.100	-0.2000	-0.2063	-0.0166	*****	*****	*****	*****	*****	*****	*****
0.150	-0.2118	-0.2072	-0.0337	*****	*****	*****	*****	*****	*****	*****
0.200	-0.2181	-0.2106	-0.0415	*****	*****	*****	*****	*****	*****	*****
0.250	*****	-0.2144	-0.0598	-0.3211	-0.3548	*****	*****	*****	*****	*****
0.300	-0.2357	-0.2185	-0.0841	-0.3082	-0.4913	*****	*****	*****	*****	*****
0.350	*****	-0.2390	-0.1049	-0.2972	-0.4641	*****	*****	*****	*****	*****
0.400	-0.2738	-0.2590	-0.1306	-0.2867	-0.4097	*****	*****	*****	*****	*****
0.450	-0.3004	-0.2803	-0.1405	-0.2734	-0.5526	*****	*****	*****	*****	*****
0.500	-0.3285	-0.2926	-0.1671	-0.2666	-0.7142	*****	*****	*****	*****	*****
0.525	*****	-0.3054	-0.1721	-0.2729	-0.7478	*****	*****	*****	*****	*****
0.550	-0.3549	-0.3178	-0.1894	-0.2842	-0.7629	*****	*****	*****	*****	*****
0.575	*****	-0.3249	-0.2162	-0.2986	-0.7870	*****	*****	*****	*****	*****
0.600	-0.3937	-0.3294	-0.3085	-0.3222	-0.8225	*****	*****	*****	*****	*****
0.625	*****	*****	-0.3494	-0.3569	-0.8938	*****	*****	*****	*****	*****
0.650	-0.4340	-0.3445	-0.3887	-0.4413	-1.0063	*****	*****	*****	*****	*****
0.675	*****	-0.3795	-0.4144	-0.5871	-1.1033	*****	*****	*****	*****	*****
0.700	-0.4753	-0.4003	-0.4469	-0.7545	-1.1344	*****	*****	*****	*****	*****
0.725	*****	-0.4156	*****	-0.8805	-0.9799	*****	*****	*****	*****	*****
0.750	-0.5178	-0.4254	*****	-0.9174	-0.8362	*****	*****	*****	*****	*****
0.775	*****	-0.4567	-0.7541	-0.9311	-0.7409	*****	*****	*****	*****	*****
0.800	-0.5593	-0.7258	-0.7993	-0.8769	*****	*****	*****	*****	*****	*****
0.825	*****	-0.9551	-0.8423	-0.8321	-0.6018	*****	*****	*****	*****	*****
0.850	-0.6066	-1.0373	-0.9133	-0.7328	-0.5787	*****	*****	*****	*****	*****
0.875	*****	-0.9886	-0.9907	-0.6689	-0.5614	*****	*****	*****	*****	*****
0.900	-0.6619	-0.8861	-0.9803	-0.6490	-0.5516	*****	*****	*****	*****	*****
0.925	*****	-1.0007	-0.9322	-0.7100	-0.4988	*****	*****	*****	*****	*****
0.950	-0.9514	-1.2751	-0.8768	-0.8498	-0.4294	*****	*****	*****	*****	*****
0.975	*****	-1.2885	-0.8420	-0.7050	-0.4288	*****	*****	*****	*****	*****
1.000	-0.9362	-1.1848	-1.0583	-1.1482	-0.6088	*****	*****	*****	*****	*****
-0.200	$C_{p,l}$	$C_{p,l}$	$C_{p,l}$	$C_{p,l}$	$C_{p,l}$	$C_{p,l}$	$C_{p,l}$	$C_{p,l}$	$C_{p,l}$	$C_{p,l}$
-0.400	0.2458	0.2357	0.2707	*****	*****	*****	*****	*****	*****	*****
-0.600	0.2427	0.2458	0.2439	0.0751	-0.6244	*****	*****	*****	*****	*****
-0.700	0.2609	0.2504	0.2380	0.1115	-0.5995	*****	*****	*****	*****	*****
-0.800	0.2810	0.2524	0.2407	0.1267	-0.5735	*****	*****	*****	*****	*****
-0.850	0.3024	*****	0.2473	0.1499	-0.5135	*****	*****	*****	*****	*****
-0.900	*****	0.2885	0.2570	0.1633	-0.5121	*****	*****	*****	*****	*****
-0.950	0.2689	0.2704	0.2611	0.1996	-0.1685	*****	*****	*****	*****	*****
-0.975	*****	0.1838	0.1952	0.1643	-0.0626	*****	*****	*****	*****	*****
-1.000	-0.9755	-1.1152	-1.1153	-1.0131	-0.6582	*****	*****	*****	*****	*****

Medium Radius L.E.

Run No. = 28 , Point No. = 564

$C_N = 0.552$, $C_m = -0.1137$

$\alpha = 11.3^\circ$, $M_\infty = 0.900$

$R_{mac} = 59.7 \times 10^6$

Leading Edge Pressures

● starboard
○ port

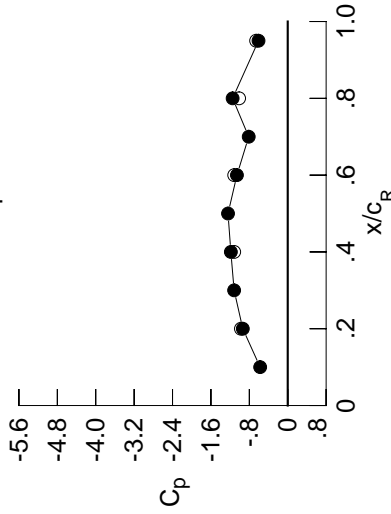

x/c_R	starb'd C_p	port C_p
0.10	-0.5746	*****
0.20	-0.9362	-0.9755
0.30	-1.1170	*****
0.40	-1.1848	-1.1152
0.50	-1.2441	*****
0.60	-1.0583	-1.1153
0.70	-0.8131	*****
0.80	-1.1482	-1.0131
0.90	*****	*****
0.95	-0.6088	-0.6582

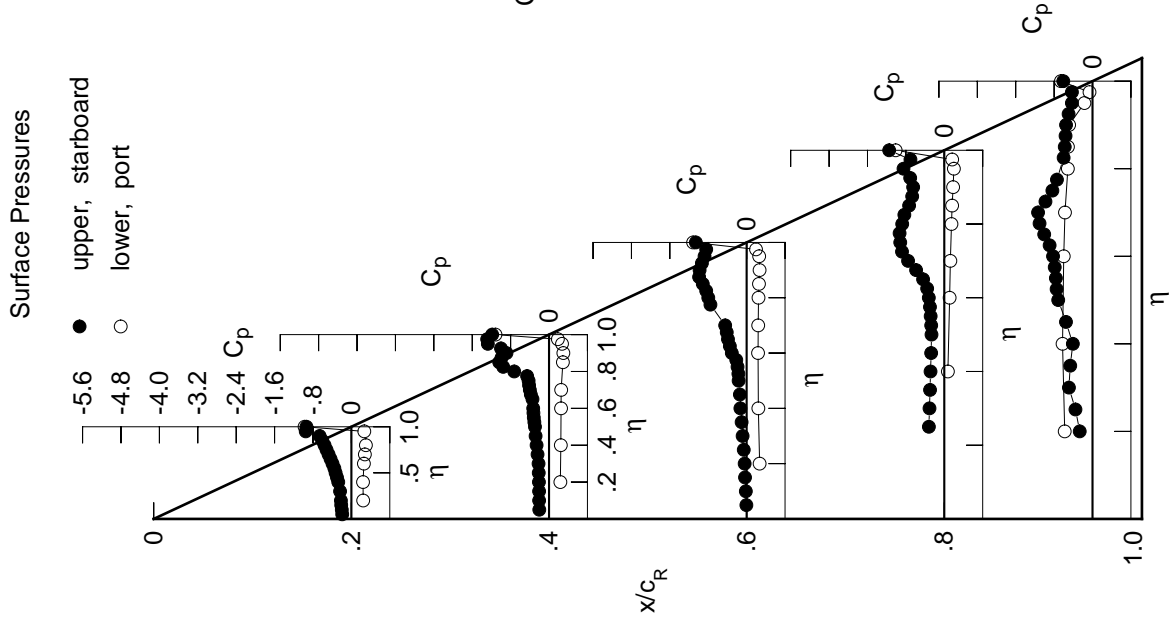
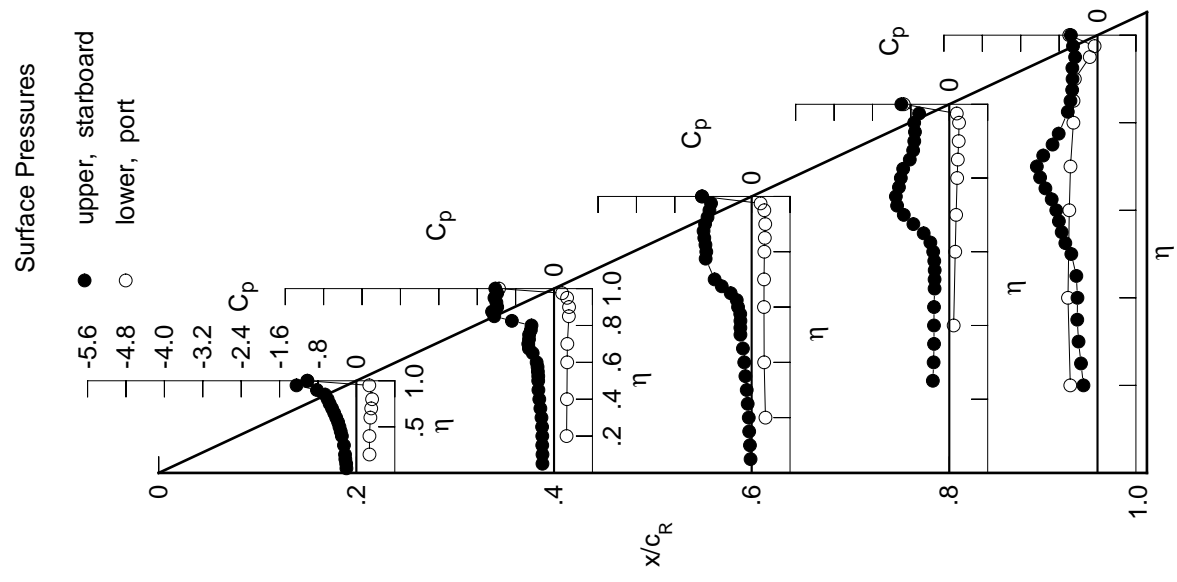
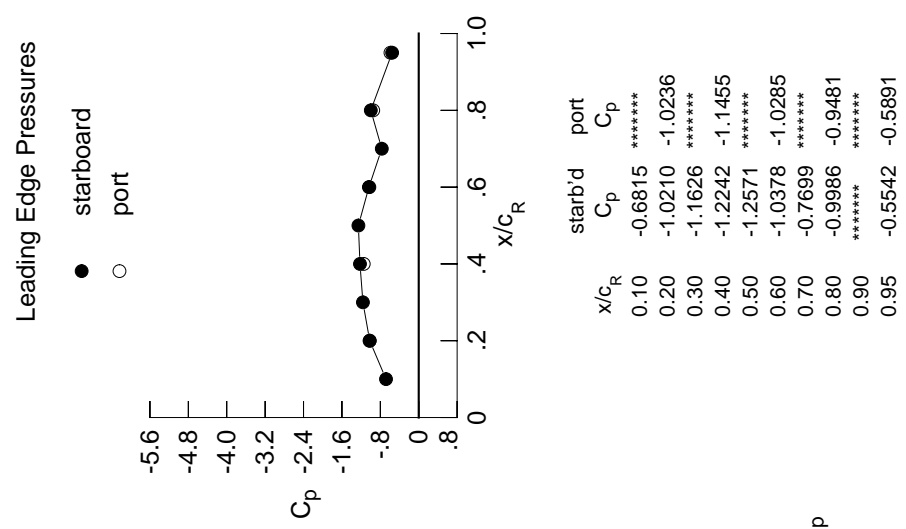

Table G4. Continued.

η	$x/c_R = .2$		$x/c_R = .4$		$x/c_R = .6$		$x/c_R = .8$		$x/c_R = .95$	
	$C_{p,u}$	$C_{p,u}$	$C_{p,u}$	$C_{p,u}$	$C_{p,u}$	$C_{p,u}$	$C_{p,u}$	$C_{p,u}$	$C_{p,u}$	$C_{p,u}$
0.050	-0.2076	-0.2415	-0.0222	*****	*****	*****	*****	*****	*****	*****
0.100	-0.2126	-0.2404	-0.0351	*****	*****	*****	*****	*****	*****	*****
0.150	-0.2301	-0.2460	-0.0512	*****	*****	*****	*****	*****	*****	*****
0.200	-0.2372	-0.2446	-0.0598	*****	*****	*****	*****	*****	*****	-0.2925
0.250	*****	-0.2488	-0.0822	-0.3420	-0.3420	-0.3420	-0.3420	-0.3420	-0.3420	-0.3437
0.300	-0.2588	-0.2617	-0.1021	-0.3261	-0.3261	-0.3261	-0.3261	-0.3261	-0.3261	-0.3955
0.350	*****	-0.2849	-0.1307	-0.3177	-0.3177	-0.3177	-0.3177	-0.3177	-0.3177	-0.4218
0.400	-0.3023	-0.3070	-0.1540	-0.3193	-0.3193	-0.3193	-0.3193	-0.3193	-0.3193	-0.4173
0.450	-0.3265	-0.3254	-0.1815	-0.3181	-0.3181	-0.3181	-0.3181	-0.3181	-0.3181	-0.4410
0.500	-0.3531	-0.3295	-0.2336	-0.3065	-0.3065	-0.3065	-0.3065	-0.3065	-0.3065	-0.5453
0.525	*****	-0.3291	-0.2356	-0.3063	-0.3063	-0.3063	-0.3063	-0.3063	-0.3063	-0.6701
0.550	-0.3812	-0.3370	-0.2338	-0.3042	-0.3042	-0.3042	-0.3042	-0.3042	-0.3042	-0.7466
0.575	*****	-0.3431	-0.2372	-0.3125	-0.3125	-0.3125	-0.3125	-0.3125	-0.3125	-0.8046
0.600	-0.4208	-0.3624	-0.2831	-0.3354	-0.3354	-0.3354	-0.3354	-0.3354	-0.3354	-0.8590
0.625	*****	*****	-0.3105	-0.3947	-0.3947	-0.3947	-0.3947	-0.3947	-0.3947	-0.9547
0.650	-0.4628	-0.4446	-0.4361	-0.5338	-1.0858	-1.0858	-1.0858	-1.0858	-1.0858	-1.0858
0.675	*****	-0.5233	-0.6227	-0.7476	-1.1963	-1.1963	-1.1963	-1.1963	-1.1963	-1.1963
0.700	-0.5069	-0.5368	-0.7708	-0.9477	-1.2638	-1.2638	-1.2638	-1.2638	-1.2638	-1.2638
0.725	*****	-0.5217	*****	-1.0869	-1.1312	-1.1312	-1.1312	-1.1312	-1.1312	-1.1312
0.750	-0.5567	-0.5194	*****	-1.1126	-0.9367	-0.9367	-0.9367	-0.9367	-0.9367	-0.9367
0.775	*****	-0.4835	-0.9581	-1.0488	-0.8086	-0.8086	-0.8086	-0.8086	-0.8086	-0.8086
0.800	-0.5983	-0.4693	-0.9446	-1.0094	*****	*****	*****	*****	*****	*****
0.825	*****	-0.8781	-0.9624	-0.9604	-0.6194	-0.6194	-0.6194	-0.6194	-0.6194	-0.6194
0.850	-0.6520	-1.2445	-0.9863	-0.8232	-0.5628	-0.5628	-0.5628	-0.5628	-0.5628	-0.5628
0.875	*****	-1.2909	-1.0018	-0.7531	-0.5278	-0.5278	-0.5278	-0.5278	-0.5278	-0.5278
0.900	-0.8223	-1.1841	-0.9703	-0.7294	-0.5198	-0.5198	-0.5198	-0.5198	-0.5198	-0.5198
0.925	*****	-1.2006	-0.9195	-0.7155	-0.5242	-0.5242	-0.5242	-0.5242	-0.5242	-0.5242
0.950	-1.2471	-1.2418	-0.8789	-0.7315	-0.4665	-0.4665	-0.4665	-0.4665	-0.4665	-0.4665
0.975	*****	-1.1837	-0.8458	-0.6285	-0.5107	-0.5107	-0.5107	-0.5107	-0.5107	-0.5107
1.000	-1.0210	-1.2242	-1.0378	-0.9986	-0.5542	-0.5542	-0.5542	-0.5542	-0.5542	-0.5542
-0.200	$C_{p,l}$	$C_{p,l}$	$C_{p,l}$	$C_{p,l}$	$C_{p,l}$	$C_{p,l}$	$C_{p,l}$	$C_{p,l}$	$C_{p,l}$	$C_{p,l}$
-0.400	0.2729	0.2610	0.2877	*****	-0.5668	-0.5668	-0.5668	-0.5668	-0.5668	-0.5668
-0.600	0.2717	0.2686	0.2608	0.0910	-0.6152	-0.6152	-0.6152	-0.6152	-0.6152	-0.6152
-0.700	0.2910	0.2746	0.2571	0.1238	-0.5881	-0.5881	-0.5881	-0.5881	-0.5881	-0.5881
-0.800	0.3091	0.2770	0.2584	0.1422	-0.5630	-0.5630	-0.5630	-0.5630	-0.5630	-0.5630
-0.850	0.3276	*****	0.2649	0.1642	-0.5025	-0.5025	-0.5025	-0.5025	-0.5025	-0.5025
-0.900	*****	0.3092	0.2744	0.1777	-0.5000	-0.5000	-0.5000	-0.5000	-0.5000	-0.5000
-0.950	*****	0.3125	0.2832	0.1958	-0.4717	-0.4717	-0.4717	-0.4717	-0.4717	-0.4717
-0.975	0.2687	0.2724	0.2638	0.2032	-0.1612	-0.1612	-0.1612	-0.1612	-0.1612	-0.1612
-1.000	*****	0.1692	0.1858	0.1557	-0.0607	-0.0607	-0.0607	-0.0607	-0.0607	-0.0607
-1.000	-1.0236	-1.1455	-1.0285	-0.9481	-0.5891	-0.5891	-0.5891	-0.5891	-0.5891	-0.5891

Medium Radius L.E.
 Run No. = 28 , Point No. = 565
 $C_N = 0.616$, $C_m = -0.1261$
 $\alpha = 12.4^\circ$, $M_\infty = 0.901$
 $R_{mac} = 59.9 \times 10^6$



x/c_R	starb'd C_p	port C_p
0.10	-0.6815	*****
0.20	-1.0210	-1.0236
0.30	-1.1626	*****
0.40	-1.2242	-1.1455
0.50	-1.2571	*****
0.60	-1.0378	-1.0285
0.70	-0.7699	*****
0.80	-0.9986	-0.9481
0.90	*****	*****
0.95	-0.5542	-0.5891

Table G4. Continued.

η	$x/c_R = .2$		$x/c_R = .4$		$x/c_R = .6$		$x/c_R = .8$		$x/c_R = .95$	
	$C_{p,u}$	$C_{p,u}$	$C_{p,u}$	$C_{p,u}$	$C_{p,u}$	$C_{p,u}$	$C_{p,u}$	$C_{p,u}$	$C_{p,u}$	$C_{p,u}$
0.050	-0.2196	-0.2700	-0.0371	*****	*****	*****	*****	*****	*****	*****
0.100	-0.2216	-0.2717	-0.0496	*****	*****	*****	*****	*****	*****	*****
0.150	-0.2409	-0.2763	-0.0624	*****	*****	*****	*****	*****	*****	*****
0.200	-0.2559	-0.2739	-0.0796	*****	*****	*****	*****	*****	*****	-0.2830
0.250	*****	-0.2855	-0.0985	-0.3643	-0.3085	*****	*****	*****	*****	*****
0.300	-0.2883	-0.2991	-0.1300	-0.3540	-0.3546	*****	*****	*****	*****	*****
0.350	*****	-0.3301	-0.1632	-0.3438	-0.3652	*****	*****	*****	*****	*****
0.400	-0.3296	-0.3459	-0.1729	-0.3264	-0.3941	*****	*****	*****	*****	*****
0.450	-0.3487	-0.3827	-0.1629	-0.3121	-0.5888	*****	*****	*****	*****	*****
0.500	-0.3750	-0.3837	-0.1824	-0.2979	-0.7678	*****	*****	*****	*****	*****
0.525	*****	-0.3823	-0.1980	-0.2989	-0.8080	*****	*****	*****	*****	*****
0.550	-0.4030	-0.3875	-0.2427	-0.3097	-0.8332	*****	*****	*****	*****	*****
0.575	*****	-0.3896	-0.3286	-0.3553	-0.8895	*****	*****	*****	*****	*****
0.600	-0.4435	-0.3947	-0.5392	-0.4503	-0.9732	*****	*****	*****	*****	*****
0.625	*****	*****	-0.7057	-0.6133	-1.0908	*****	*****	*****	*****	*****
0.650	-0.4854	-0.4683	-0.8561	-0.8287	-1.2102	*****	*****	*****	*****	*****
0.675	*****	-0.6105	-0.9545	-1.0355	-1.2373	*****	*****	*****	*****	*****
0.700	-0.5321	-0.7797	-1.0027	-1.1829	-1.0294	*****	*****	*****	*****	*****
0.725	*****	-0.8501	*****	-1.2688	-0.9971	*****	*****	*****	*****	*****
0.750	-0.5757	-0.8826	*****	-1.2598	-0.8991	*****	*****	*****	*****	*****
0.775	*****	-0.9489	-0.9966	-1.0907	-0.7352	*****	*****	*****	*****	*****
0.800	-0.6476	-1.0568	-0.9984	-0.9927	*****	*****	*****	*****	*****	*****
0.825	*****	-1.1419	-1.0201	-0.9096	-0.5913	*****	*****	*****	*****	*****
0.850	-0.9344	-1.1537	-1.0279	-0.8190	-0.5416	*****	*****	*****	*****	*****
0.875	*****	-1.0974	-1.0102	-0.7881	-0.5233	*****	*****	*****	*****	*****
0.900	-1.1786	-1.0105	-0.9587	-0.7743	-0.5439	*****	*****	*****	*****	*****
0.925	*****	-0.9888	-0.9119	-0.7083	-0.5634	*****	*****	*****	*****	*****
0.950	-1.2743	-1.1811	-0.8766	-0.6951	-0.5196	*****	*****	*****	*****	*****
0.975	*****	-1.1407	-0.8465	-0.6142	-0.5441	*****	*****	*****	*****	*****
1.000	-1.0929	-1.2367	-1.0025	-0.9156	-0.5586	*****	*****	*****	*****	*****
-0.200	$C_{p,l}$	$C_{p,l}$	$C_{p,l}$	$C_{p,l}$	$C_{p,l}$	$C_{p,l}$	$C_{p,l}$	$C_{p,l}$	$C_{p,l}$	$C_{p,l}$
-0.400	0.3031	0.2841	0.3042	*****	-0.5587	*****	*****	*****	*****	*****
-0.600	0.3026	0.2933	0.2787	0.1043	-0.6078	*****	*****	*****	*****	*****
-0.700	0.3214	0.2986	0.2732	0.1403	-0.5819	*****	*****	*****	*****	*****
-0.800	0.3385	0.3017	0.2765	0.1553	-0.5560	*****	*****	*****	*****	*****
-0.850	0.3525	*****	0.2823	0.1787	-0.4933	*****	*****	*****	*****	*****
-0.900	*****	0.3299	0.2905	0.1906	-0.4906	*****	*****	*****	*****	*****
-0.950	*****	0.3282	0.2949	0.2087	-0.4594	*****	*****	*****	*****	*****
-0.975	0.2683	0.2760	0.2631	0.2067	-0.1580	*****	*****	*****	*****	*****
-1.000	*****	0.1592	0.1711	0.1480	-0.0665	*****	*****	*****	*****	*****
	-1.0694	-1.1461	-0.9785	-0.8927	-0.5712	*****	*****	*****	*****	*****

Medium Radius L.E.
 Run No. = 28 , Point No. = 566
 $C_N = 0.678$, $C_m = -0.1365$
 $\alpha = 13.4^\circ$, $M_\infty = 0.900$
 $R_{mac} = 59.8 \times 10^6$

Leading Edge Pressures

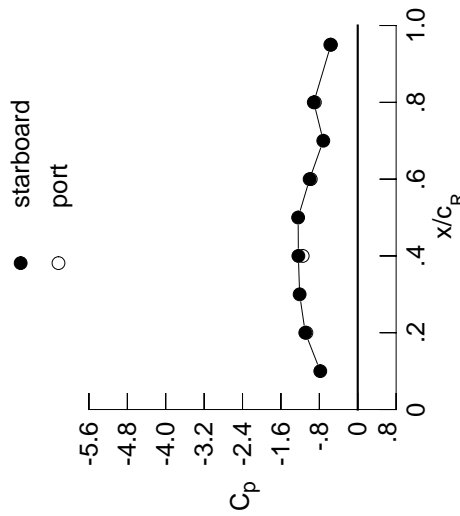

x/c_R	starb'd C_p	port C_p
0.10	-0.7797	*****
0.20	-1.0929	-1.0694
0.30	-1.2105	*****
0.40	-1.2367	-1.1461
0.50	-1.2416	*****
0.60	-1.0025	-0.9785
0.70	-0.7180	*****
0.80	-0.9156	-0.8927
0.90	*****	*****
0.95	-0.5586	-0.5712

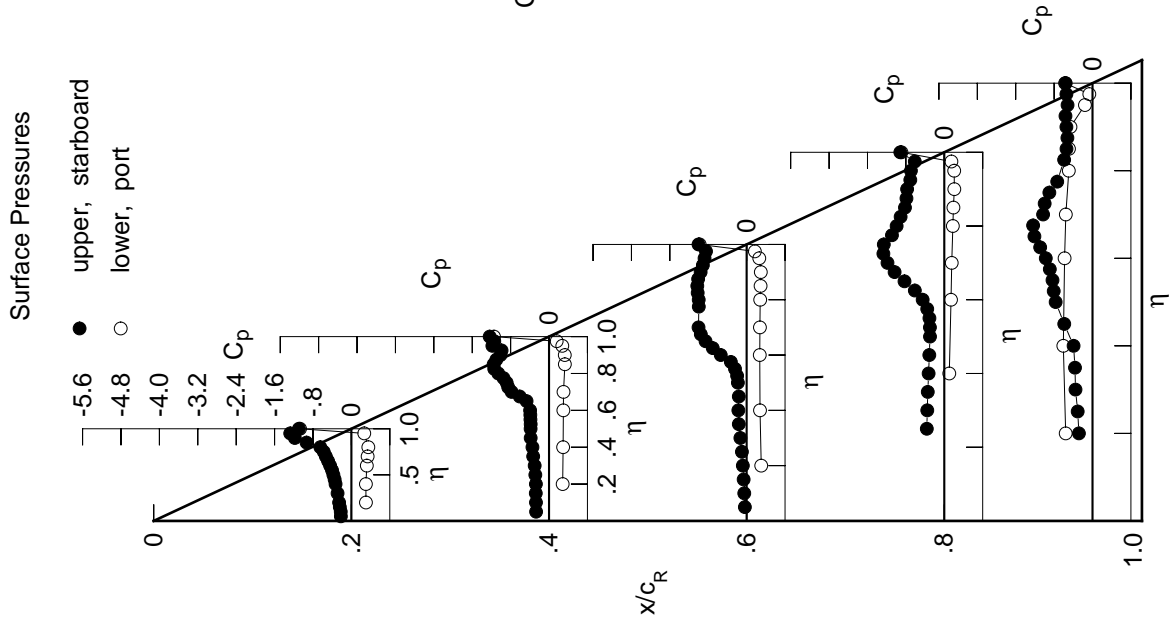
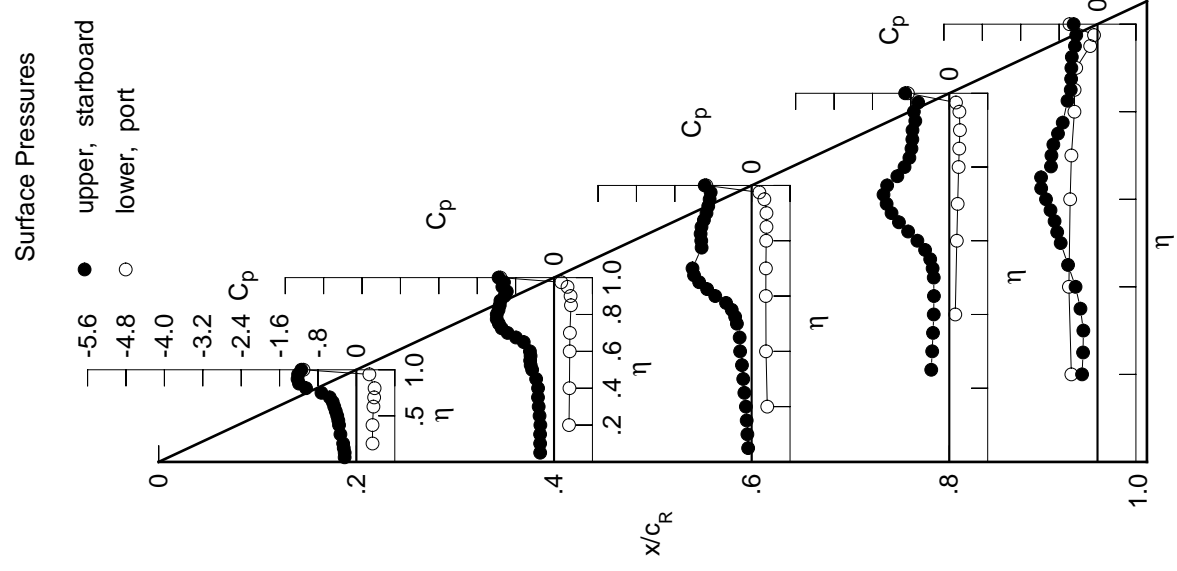
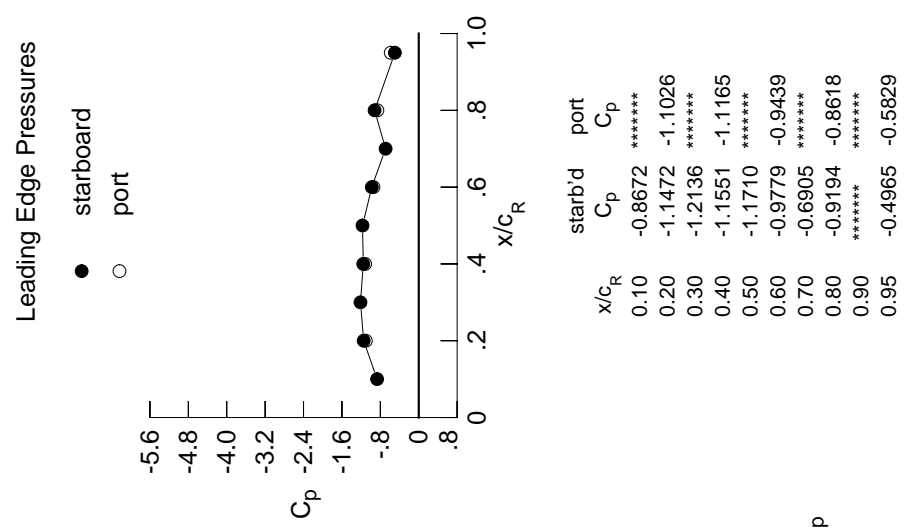

Table G4. Continued.

η	$x/c_R = .2$		$x/c_R = .4$		$x/c_R = .6$		$x/c_R = .8$		$x/c_R = .95$	
	$C_{p,u}$	$C_{p,u}$	$C_{p,u}$	$C_{p,u}$	$C_{p,u}$	$C_{p,u}$	$C_{p,u}$	$C_{p,u}$	$C_{p,u}$	$C_{p,u}$
0.050	-0.2446	-0.2891	-0.0731	*****	*****	*****	*****	*****	*****	*****
0.100	-0.2439	-0.2894	-0.0885	*****	*****	*****	*****	*****	*****	*****
0.150	-0.2636	-0.2901	-0.1034	*****	*****	*****	*****	*****	*****	*****
0.200	-0.2761	-0.2851	-0.1203	*****	*****	*****	*****	*****	*****	*****
0.250	*****	-0.3013	-0.1521	-0.3759	-0.3009	*****	*****	*****	*****	*****
0.300	-0.3330	-0.3202	-0.1748	-0.3564	-0.2952	*****	*****	*****	*****	*****
0.350	*****	-0.3344	-0.2018	-0.3390	-0.3553	*****	*****	*****	*****	*****
0.400	-0.3617	-0.3326	-0.2404	-0.3243	-0.4575	*****	*****	*****	*****	*****
0.450	-0.3765	-0.3728	-0.2497	-0.3200	-0.6134	*****	*****	*****	*****	*****
0.500	-0.3990	-0.4560	-0.3070	-0.3243	-0.7673	*****	*****	*****	*****	*****
0.525	*****	-0.4866	-0.3442	-0.3471	-0.8400	*****	*****	*****	*****	*****
0.550	-0.4298	-0.4976	-0.4142	-0.3972	-0.8944	*****	*****	*****	*****	*****
0.575	*****	-0.4890	-0.5325	-0.5040	-0.9792	*****	*****	*****	*****	*****
0.600	-0.4613	-0.5025	-0.7581	-0.6650	-1.0729	*****	*****	*****	*****	*****
0.625	*****	*****	-0.9275	-0.8576	-1.1739	*****	*****	*****	*****	*****
0.650	-0.4939	-0.6313	-1.0931	-1.0487	-1.1763	*****	*****	*****	*****	*****
0.675	*****	-0.7916	-1.2000	-1.2029	-0.9695	*****	*****	*****	*****	*****
0.700	-0.5547	-0.9682	-1.2318	-1.3057	-0.9602	*****	*****	*****	*****	*****
0.725	*****	-1.0904	*****	-1.3700	-0.9203	*****	*****	*****	*****	*****
0.750	-0.7280	-1.1488	*****	-1.2944	-0.8232	*****	*****	*****	*****	*****
0.775	*****	-1.1936	-1.0425	-1.0821	-0.7244	*****	*****	*****	*****	*****
0.800	-1.0491	-1.1933	-1.0499	-0.9319	*****	*****	*****	*****	*****	*****
0.825	*****	-1.1556	-1.0628	-0.8309	-0.6259	*****	*****	*****	*****	*****
0.850	-1.1951	-1.1313	-1.0448	-0.7880	-0.5574	*****	*****	*****	*****	*****
0.875	*****	-1.1166	-0.9944	-0.7693	-0.5495	*****	*****	*****	*****	*****
0.900	-1.2258	-1.0315	-0.9410	-0.7666	-0.5447	*****	*****	*****	*****	*****
0.925	*****	-0.9839	-0.9036	-0.7080	-0.5351	*****	*****	*****	*****	*****
0.950	-1.2141	-1.0764	-0.8756	-0.7381	-0.4694	*****	*****	*****	*****	*****
0.975	*****	-1.0431	-0.8536	-0.6482	-0.4430	*****	*****	*****	*****	*****
1.000	-1.1472	-1.1551	-0.9779	-0.9194	-0.4965	*****	*****	*****	*****	*****
-0.200	$C_{p,l}$	$C_{p,l}$	$C_{p,l}$	$C_{p,l}$	$C_{p,l}$	$C_{p,l}$	$C_{p,l}$	$C_{p,l}$	$C_{p,l}$	$C_{p,l}$
-0.400	0.3362	0.3119	0.3258	*****	*****	*****	*****	*****	*****	*****
-0.600	0.3359	0.3213	0.2996	0.1245	-0.5961	*****	*****	*****	*****	*****
-0.700	0.3554	0.3268	0.2955	0.1564	-0.5700	*****	*****	*****	*****	*****
-0.800	0.3699	0.3304	0.2968	0.1747	-0.5442	*****	*****	*****	*****	*****
-0.850	0.3796	*****	0.3030	0.1943	-0.4810	*****	*****	*****	*****	*****
-0.900	*****	0.3529	0.3088	0.2082	-0.4779	*****	*****	*****	*****	*****
-0.950	*****	0.3448	0.3092	0.2213	-0.4442	*****	*****	*****	*****	*****
-0.975	0.2707	0.2809	0.2647	0.2103	-0.1527	*****	*****	*****	*****	*****
-1.000	0.1506	0.1506	0.1610	0.1389	-0.0726	*****	*****	*****	*****	*****
-1.000	-1.1026	-1.1165	-0.9439	-0.8618	-0.5829	*****	*****	*****	*****	*****

Medium Radius L.E.
 Run No. = 28 , Point No. = 567
 $C_N = 0.738$, $C_m = -0.1458$
 $\alpha = 14.5^\circ$, $M_\infty = 0.899$
 $R_{mac} = 59.7 \times 10^6$



x/c_R	starb'd C_p	port C_p
0.10	-0.8672	*****
0.20	-1.1472	-1.1026
0.30	-1.2136	*****
0.40	-1.1551	-1.1165
0.50	-1.1710	*****
0.60	-0.9779	-0.9439
0.70	-0.6905	*****
0.80	-0.9194	-0.8618
0.90	*****	*****
0.95	-0.4965	-0.5829

Table G4. Continued.

η	$x/c_R = .2$		$x/c_R = .4$		$x/c_R = .6$		$x/c_R = .8$		$x/c_R = .95$	
	$C_{p,u}$	$C_{p,l}$	$C_{p,u}$	$C_{p,l}$	$C_{p,u}$	$C_{p,l}$	$C_{p,u}$	$C_{p,l}$	$C_{p,u}$	$C_{p,l}$
0.050	-0.2903	-0.3540	-0.3889	*****	*****	*****	*****	*****	*****	*****
0.100	-0.2836	-0.3556	-0.3930	*****	*****	*****	*****	*****	*****	*****
0.150	-0.2962	-0.3500	-0.3984	*****	*****	*****	*****	*****	*****	*****
0.200	-0.3107	-0.3536	-0.3994	*****	*****	*****	*****	*****	*****	*****
0.250	*****	-0.3767	-0.4100	-0.4006	-0.4006	-0.4006	-0.4006	-0.4006	-0.3878	*****
0.300	-0.3875	-0.3843	-0.4055	-0.3898	-0.3898	-0.3898	-0.3898	-0.3898	-0.2946	*****
0.350	*****	-0.3828	-0.4034	-0.3814	-0.2975	-0.2975	-0.2975	-0.2975	-0.2975	*****
0.400	-0.4067	-0.3793	-0.4040	-0.3746	-0.3332	-0.3332	-0.3332	-0.3332	-0.3332	*****
0.450	-0.4203	-0.3947	-0.4044	-0.3975	-0.4470	-0.4470	-0.4470	-0.4470	-0.4470	*****
0.500	-0.4472	-0.4523	-0.5409	-0.4843	-0.5721	-0.5721	-0.5721	-0.5721	-0.5721	*****
0.525	*****	-0.5537	-0.6640	-0.5727	-0.6608	-0.6608	-0.6608	-0.6608	-0.6608	*****
0.550	-0.4640	-0.7119	-0.8351	-0.6977	-0.7265	-0.7265	-0.7265	-0.7265	-0.7265	*****
0.575	*****	-0.9030	-1.0036	-0.8540	-0.8479	-0.8479	-0.8479	-0.8479	-0.8479	*****
0.600	-0.4774	-1.0874	-1.1835	-1.0097	-0.7985	-0.7985	-0.7985	-0.7985	-0.7985	*****
0.625	*****	*****	-1.2913	-1.1446	-0.7628	-0.7628	-0.7628	-0.7628	-0.7628	*****
0.650	-0.6946	-1.2506	-1.3776	-1.2607	-0.7561	-0.7561	-0.7561	-0.7561	-0.7561	*****
0.675	*****	-1.2269	-1.4368	-1.3523	-0.7409	-0.7409	-0.7409	-0.7409	-0.7409	*****
0.700	-1.0915	-1.2333	-1.4578	-1.4059	-0.7237	-0.7237	-0.7237	-0.7237	-0.7237	*****
0.725	*****	-1.2809	*****	-1.1896	-0.7114	-0.7114	-0.7114	-0.7114	-0.7114	*****
0.750	-1.0314	-1.2824	*****	-1.1564	-0.6950	-0.6950	-0.6950	-0.6950	-0.6950	*****
0.775	*****	-1.2231	-1.1717	-1.2001	-0.6430	-0.6430	-0.6430	-0.6430	-0.6430	*****
0.800	-1.1096	-1.1495	-1.1422	-1.1454	*****	*****	*****	*****	*****	*****
0.825	*****	-1.1120	-1.1050	-0.9249	-0.6329	-0.6329	-0.6329	-0.6329	-0.6329	*****
0.850	-1.3131	-1.0966	-1.0740	-0.8393	-0.5747	-0.5747	-0.5747	-0.5747	-0.5747	*****
0.875	*****	-1.0906	-1.0611	-0.8140	-0.5918	-0.5918	-0.5918	-0.5918	-0.5918	*****
0.900	-1.2999	-1.0458	-1.0307	-0.7829	-0.6292	-0.6292	-0.6292	-0.6292	-0.6292	*****
0.925	*****	-1.0208	-0.9681	-0.7293	-0.6483	-0.6483	-0.6483	-0.6483	-0.6483	*****
0.950	-1.2557	-1.0782	-0.9350	-0.7946	-0.5760	-0.5760	-0.5760	-0.5760	-0.5760	*****
0.975	*****	-0.9878	-0.9229	-0.7341	-0.5139	-0.5139	-0.5139	-0.5139	-0.5139	*****
1.000	-1.2361	-1.0943	-1.0224	-0.8997	-0.5181	-0.5181	-0.5181	-0.5181	-0.5181	*****
-0.200	$C_{p,l}$	0.3625	0.3639	*****	*****	*****	*****	*****	*****	*****
-0.400	0.3997	0.3625	0.3639	*****	*****	*****	*****	*****	*****	*****
-0.600	0.3998	0.3725	0.3376	0.1566	0.1566	0.1566	0.1566	0.1566	0.1566	*****
-0.700	0.4171	0.3764	0.3327	0.1892	0.1892	0.1892	0.1892	0.1892	0.1892	*****
-0.800	0.4278	0.3805	0.3350	0.2043	0.2043	0.2043	0.2043	0.2043	0.2043	*****
-0.850	0.4276	*****	0.3387	0.2244	0.2244	0.2244	0.2244	0.2244	0.2244	*****
-0.850	*****	0.3912	0.3404	0.2365	0.2365	0.2365	0.2365	0.2365	0.2365	*****
-0.900	*****	0.3712	0.3306	0.2439	0.2439	0.2439	0.2439	0.2439	0.2439	*****
-0.950	0.2700	0.2830	0.2626	0.2119	0.2119	0.2119	0.2119	0.2119	0.2119	*****
-0.975	*****	0.1291	0.1340	0.1162	0.1162	0.1162	0.1162	0.1162	0.1162	*****
-1.000	-1.1613	-1.0474	-1.0289	-0.8409	-0.6011	-0.6011	-0.6011	-0.6011	-0.6011	*****

Medium Radius L.E.
 Run No. = 28 , Point No. = 568
 $C_N = 0.855$, $C_m = -0.1625$
 $\alpha = 16.6^\circ$, $M_\infty = 0.900$
 $R_{mac} = 59.6 \times 10^6$

Leading Edge Pressures

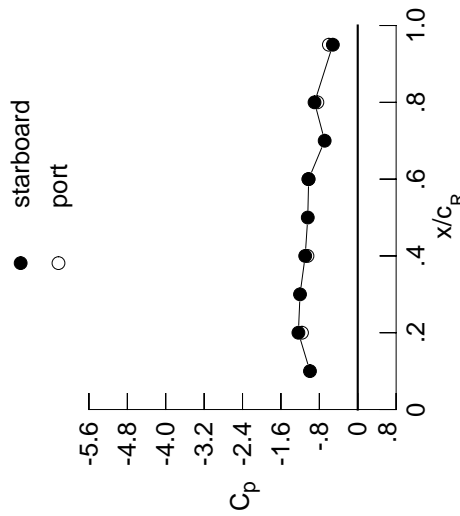

x/c_R	starb'd C_p	port C_p
0.10	-0.9955	*****
0.20	-1.2361	-1.1613
0.30	-1.2023	*****
0.40	-1.0943	-1.0474
0.50	-1.0410	*****
0.60	-1.0224	-1.0289
0.70	-0.6888	*****
0.80	-0.8997	-0.8409
0.90	*****	*****
0.95	-0.5181	-0.6011

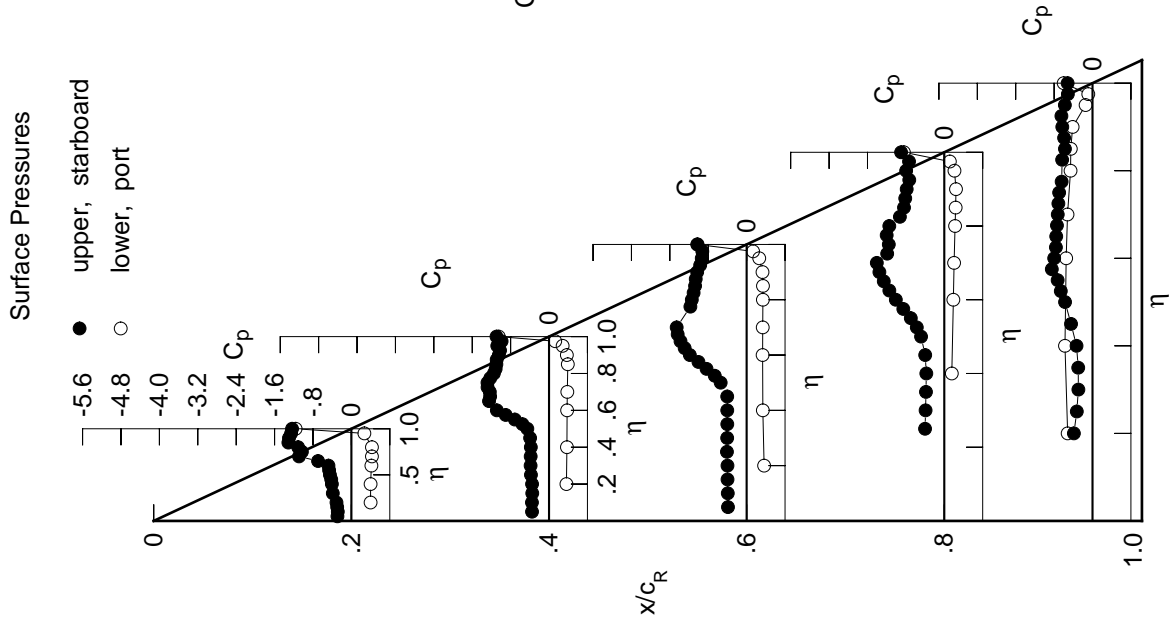
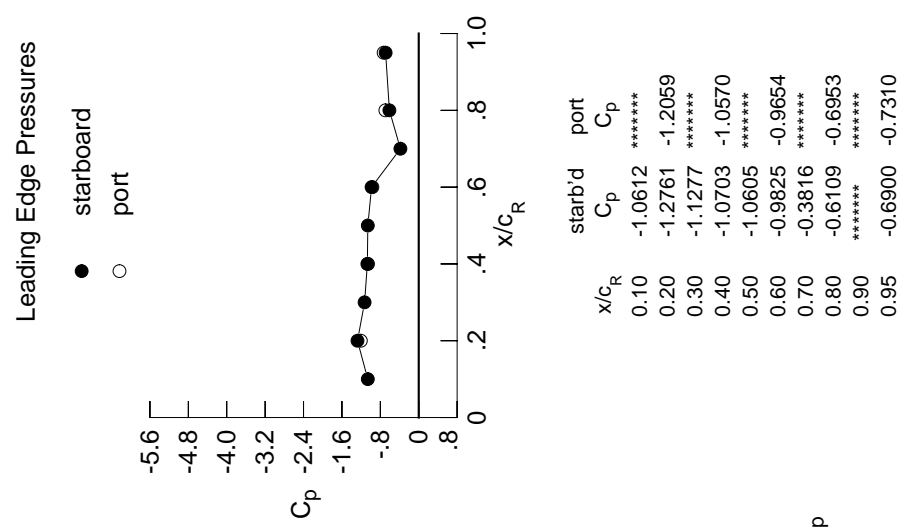

Table G4. Continued.

η	$x/c_R = .2$		$x/c_R = .4$		$x/c_R = .6$		$x/c_R = .8$		$x/c_R = .95$	
	$C_{p,u}$	$C_{p,l}$	$C_{p,u}$	$C_{p,l}$	$C_{p,u}$	$C_{p,l}$	$C_{p,u}$	$C_{p,l}$	$C_{p,u}$	$C_{p,l}$
0.050	-0.3457	-0.4197	-0.1530	*****	*****	*****	*****	*****	*****	*****
0.100	-0.3380	-0.4174	-0.1699	*****	*****	*****	*****	*****	*****	*****
0.150	-0.3445	-0.4120	-0.1953	*****	*****	*****	*****	*****	*****	*****
0.200	-0.3868	-0.4227	-0.2187	*****	*****	*****	*****	*****	*****	-0.8605
0.250	*****	-0.4341	-0.2484	-0.1188	-0.8434	*****	*****	*****	*****	-0.8434
0.300	-0.3894	-0.4329	-0.2665	-0.0901	-0.8349	*****	*****	*****	*****	-0.8349
0.350	*****	-0.4449	-0.3047	-0.0849	-0.8270	*****	*****	*****	*****	-0.8270
0.400	-0.4299	-0.4630	-0.3603	-0.0613	-0.8462	*****	*****	*****	*****	-0.8462
0.450	-0.5305	-0.5259	-0.4532	-0.1028	-0.8606	*****	*****	*****	*****	-0.8606
0.500	-0.5960	-0.6833	-0.7156	-0.2347	-0.8453	*****	*****	*****	*****	-0.8453
0.525	*****	-0.8394	-0.8749	-0.3391	-0.8475	*****	*****	*****	*****	-0.8475
0.550	-0.6460	-1.0295	-1.0280	-0.4611	-0.8060	*****	*****	*****	*****	-0.8060
0.575	*****	-1.1914	-1.1572	-0.6002	-0.7934	*****	*****	*****	*****	-0.7934
0.600	-0.8453	-1.3228	-1.2845	-0.7110	-0.7559	*****	*****	*****	*****	-0.7559
0.625	*****	*****	-1.3502	-0.7575	-0.7286	*****	*****	*****	*****	-0.7286
0.650	-1.1794	-1.4737	-1.4181	-0.6739	-0.7140	*****	*****	*****	*****	-0.7140
0.675	*****	-1.4757	-1.4378	-0.5635	-0.6894	*****	*****	*****	*****	-0.6894
0.700	-1.2590	-1.3685	-1.2996	-0.5504	-0.6857	*****	*****	*****	*****	-0.6857
0.725	*****	-1.3073	*****	-0.5064	-0.6855	*****	*****	*****	*****	-0.6855
0.750	-1.2019	-1.3228	*****	-0.4537	-0.6827	*****	*****	*****	*****	-0.6827
0.775	*****	-1.2907	-1.1947	-0.4386	-0.6818	*****	*****	*****	*****	-0.6818
0.800	-1.2580	-1.1842	-1.1603	-0.4318	*****	*****	*****	*****	*****	-0.6818
0.825	*****	-1.1225	-1.1166	-0.4352	-0.6859	*****	*****	*****	*****	-0.6859
0.850	-1.3074	-1.0825	-1.0382	-0.4599	-0.6667	*****	*****	*****	*****	-0.6667
0.875	*****	-1.0651	-0.9852	-0.4627	-0.6723	*****	*****	*****	*****	-0.6723
0.900	-1.2398	-1.0579	-0.9487	-0.4574	-0.6741	*****	*****	*****	*****	-0.6741
0.925	*****	-1.0492	-0.9212	-0.4596	-0.6814	*****	*****	*****	*****	-0.6814
0.950	-1.2065	-1.0673	-0.9038	-0.4898	-0.6161	*****	*****	*****	*****	-0.6161
0.975	*****	-0.9872	-0.9006	-0.4925	-0.5923	*****	*****	*****	*****	-0.5923
1.000	-1.2761	-1.0703	-0.9825	-0.6109	-0.6900	*****	*****	*****	*****	-0.6900
-0.200	$C_{p,l}$	$C_{p,l}$	$C_{p,l}$	$C_{p,l}$	$C_{p,l}$	$C_{p,l}$	$C_{p,l}$	$C_{p,l}$	$C_{p,l}$	$C_{p,l}$
-0.400	0.4573	0.4108	0.3991	*****	*****	*****	*****	*****	*****	-0.5085
-0.600	0.4589	0.4203	0.3754	0.1846	0.5641	*****	*****	*****	*****	-0.5641
-0.700	0.4738	0.4229	0.3706	0.2179	-0.5374	*****	*****	*****	*****	-0.5374
-0.800	0.4794	0.4259	0.3734	0.2343	-0.5114	*****	*****	*****	*****	-0.5114
-0.850	0.4698	*****	0.3760	0.2529	-0.4488	*****	*****	*****	*****	-0.4488
-0.900	*****	0.4248	0.3743	0.2646	-0.4452	*****	*****	*****	*****	-0.4452
-0.950	*****	0.3921	0.3561	0.2699	-0.4102	*****	*****	*****	*****	-0.4102
-0.975	0.2688	0.2825	0.2682	0.2336	-0.1555	*****	*****	*****	*****	-0.1555
-1.000	*****	0.1054	0.1184	0.1389	-0.1145	*****	*****	*****	*****	-0.1145
-1.000	-1.2059	-1.0570	-0.9654	-0.6953	-0.7310	*****	*****	*****	*****	-0.7310

Medium Radius L.E.
 Run No. = 28 , Point No. = 569
 $C_N = 0.817$, $C_m = -0.1232$
 $\alpha = 18.5^\circ$, $M_\infty = 0.901$
 $R_{mac} = 59.6 \times 10^6$



x/c_R	starb'd C_p	port C_p
0.10	-1.0612	*****
0.20	-1.2761	-1.2059
0.30	-1.1277	*****
0.40	-1.0703	-1.0570
0.50	-1.0605	*****
0.60	-0.9825	-0.9654
0.70	-0.3816	*****
0.80	-0.6109	-0.6953
0.90	*****	*****
0.95	-0.6900	-0.7310

Table G4. Continued.

η	$x/c_R = .2$		$x/c_R = .4$		$x/c_R = .6$		$x/c_R = .8$		$x/c_R = .95$	
	$C_{p,u}$	$C_{p,u}$	$C_{p,u}$	$C_{p,u}$	$C_{p,u}$	$C_{p,u}$	$C_{p,u}$	$C_{p,u}$	$C_{p,u}$	$C_{p,u}$
0.050	-0.4156	-0.4894	-0.1974	*****	*****	*****	*****	*****	*****	*****
0.100	-0.4078	-0.4844	-0.2140	*****	*****	*****	*****	*****	*****	*****
0.150	-0.4471	-0.4822	-0.2408	*****	*****	*****	*****	*****	*****	*****
0.200	-0.4492	-0.4994	-0.2663	*****	*****	*****	*****	*****	*****	-0.8079
0.250	*****	-0.5023	-0.3100	-0.2963	-0.3100	-0.2963	-0.3100	-0.2963	-0.3100	-0.7562
0.300	-0.4424	-0.5078	-0.3442	-0.3056	-0.3442	-0.3056	-0.3442	-0.3056	-0.3442	-0.7149
0.350	*****	-0.5340	-0.4094	-0.3657	-0.4094	-0.3657	-0.4094	-0.3657	-0.4094	-0.7277
0.400	-0.4633	-0.5943	-0.5151	-0.4271	-0.5151	-0.4271	-0.5151	-0.4271	-0.5151	-0.7578
0.450	-0.4926	-0.7487	-0.6723	-0.5622	-0.6723	-0.5622	-0.6723	-0.5622	-0.6723	-0.8002
0.500	-0.6441	-0.9743	-0.9423	-0.7210	-0.9423	-0.7210	-0.9423	-0.7210	-0.9423	-0.8100
0.525	*****	-1.1039	-1.0713	-0.7901	-1.0713	-0.7901	-1.0713	-0.7901	-1.0713	-0.8315
0.550	-1.0911	-1.2402	-1.1879	-0.8382	-1.1879	-0.8382	-1.1879	-0.8382	-1.1879	-0.8042
0.575	*****	-1.3373	-1.2861	-0.8677	-1.2861	-0.8677	-1.2861	-0.8677	-1.2861	-0.8021
0.600	-1.4350	-1.4185	-1.3819	-0.8657	-1.3819	-0.8657	-1.3819	-0.8657	-1.3819	-0.7762
0.625	*****	*****	-1.3734	-0.8028	-1.3734	-0.8028	-1.3734	-0.8028	-1.3734	-0.7638
0.650	-1.5421	-1.5362	-1.2085	-0.7965	-1.2085	-0.7965	-1.2085	-0.7965	-1.2085	-0.7581
0.675	*****	-1.5462	-1.1821	-0.8356	-1.1821	-0.8356	-1.1821	-0.8356	-1.1821	-0.7387
0.700	-1.3483	-1.4148	-1.1746	-0.7839	-1.1746	-0.7839	-1.1746	-0.7839	-1.1746	-0.7301
0.725	*****	-1.3947	*****	-0.7386	-0.7386	-0.7386	-0.7386	-0.7386	-0.7386	-0.7271
0.750	-1.2949	-1.3560	*****	-0.6939	-0.6939	-0.6939	-0.6939	-0.6939	-0.6939	-0.7209
0.775	*****	-1.3188	-1.2381	-0.6759	-1.2381	-0.6759	-1.2381	-0.6759	-1.2381	-0.7135
0.800	-1.3373	-1.2531	-1.2990	-0.6668	-1.2990	-0.6668	-1.2990	-0.6668	-1.2990	*****
0.825	*****	-1.2039	-1.2665	-0.6553	-1.2665	-0.6553	-1.2665	-0.6553	-1.2665	-0.6996
0.850	-1.3181	-1.1683	-1.0798	-0.6650	-1.0798	-0.6650	-1.0798	-0.6650	-1.0798	-0.6746
0.875	*****	-1.1211	-0.9666	-0.6599	-0.9666	-0.6599	-0.9666	-0.6599	-0.9666	-0.6620
0.900	-1.2139	-1.0905	-0.9567	-0.6560	-0.9567	-0.6560	-0.9567	-0.6560	-0.9567	-0.6411
0.925	*****	-1.0836	-0.9712	-0.6513	-0.9712	-0.6513	-0.9712	-0.6513	-0.9712	-0.6262
0.950	-1.1762	-1.1167	-0.9737	-0.6715	-0.9737	-0.6715	-0.9737	-0.6715	-0.9737	-0.5696
0.975	*****	-1.0743	-0.9639	-0.6629	-0.9639	-0.6629	-0.9639	-0.6629	-0.9639	-0.5310
1.000	-1.3044	-1.1188	-1.0323	-0.7324	-1.0323	-0.7324	-1.0323	-0.7324	-1.0323	-0.5437
	$C_{p,l}$	$C_{p,l}$	$C_{p,l}$	$C_{p,l}$	$C_{p,l}$	$C_{p,l}$	$C_{p,l}$	$C_{p,l}$	$C_{p,l}$	$C_{p,l}$
-0.200	0.5135	0.4590	0.4354	*****	*****	*****	*****	*****	*****	-0.4816
-0.400	0.5163	0.4657	0.4112	0.2169	0.4112	0.2169	0.4112	0.2169	0.4112	-0.5430
-0.600	0.5283	0.4677	0.4060	0.2456	0.4060	0.2456	0.4060	0.2456	0.4060	-0.5168
-0.700	0.5279	0.4693	0.4073	0.2612	0.4073	0.2612	0.4073	0.2612	0.4073	-0.4884
-0.800	0.5077	*****	0.4056	0.2769	0.4056	0.2769	0.4056	0.2769	0.4056	-0.4239
-0.850	*****	0.4530	0.3991	0.2849	0.3991	0.2849	0.3991	0.2849	0.3991	-0.4179
-0.900	*****	0.4077	0.3692	0.2819	0.3692	0.2819	0.3692	0.2819	0.3692	-0.3774
-0.950	0.2605	0.2745	0.2575	0.2220	0.2575	0.2220	0.2575	0.2220	0.2575	-0.1408
-0.975	*****	0.0739	0.0844	0.0980	0.0844	0.0980	0.0844	0.0980	0.0844	-0.1171
-1.000	-1.2288	-1.1222	-1.0585	-0.7211	-1.0585	-0.7211	-1.0585	-0.7211	-1.0585	-0.6315

Medium Radius L.E.

Run No. = 28 , Point No. = 570

$C_N = 0.939$, $C_m = -0.1540$

$\alpha = 20.6^\circ$, $M_\infty = 0.900$

$R_{mac} = 59.7 \times 10^6$

Leading Edge Pressures

● starboard
○ port

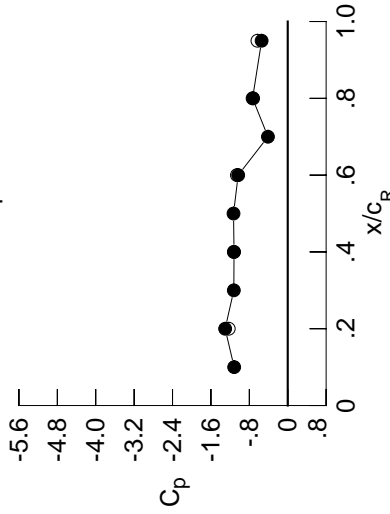

x/c_R	starb'd C_p	port C_p
0.10	-1.1162	*****
0.20	-1.3044	-1.2288
0.30	-1.1231	*****
0.40	-1.1188	-1.1222
0.50	-1.1293	*****
0.60	-1.0323	-1.0585
0.70	-0.4117	*****
0.80	-0.7324	-0.7211
0.90	*****	*****
0.95	-0.5437	-0.6315

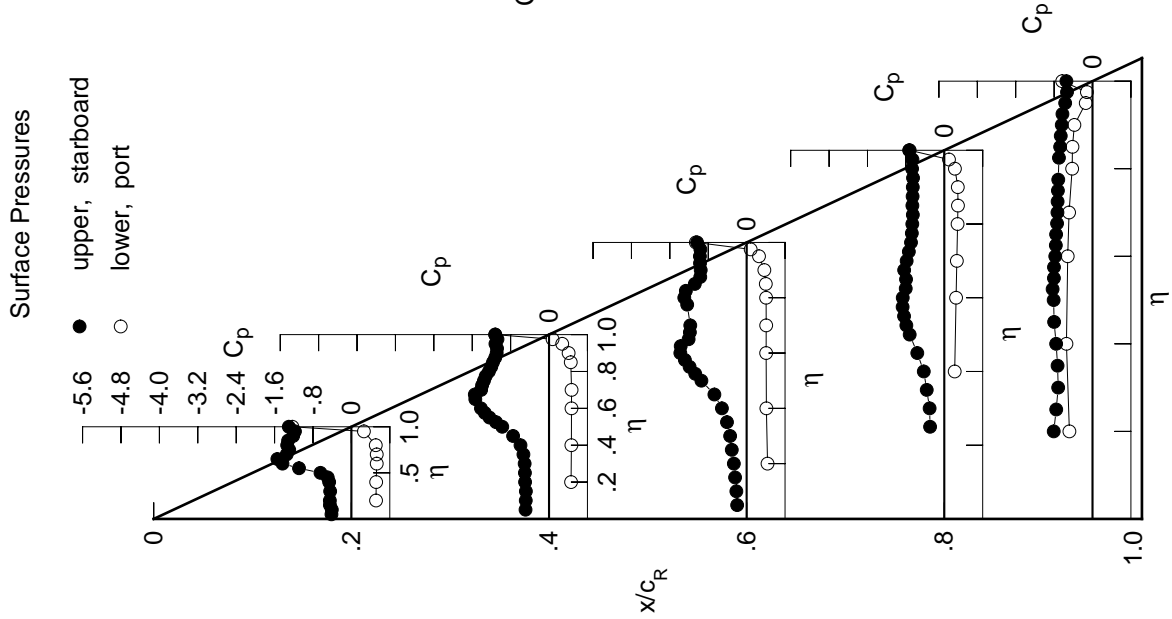

Table G4. Continued.

η	x/c_R .2	$C_{p,u}$	x/c_R .4	$C_{p,u}$	x/c_R .6	$C_{p,u}$	x/c_R .8	$C_{p,u}$	x/c_R .95	$C_{p,u}$
0.050		-0.4863		-0.5570		-0.0672		*****		*****
0.100		-0.4817		-0.5588		-0.0845		*****		*****
0.150		-0.5163		-0.5582		-0.1037		*****		*****
0.200		-0.5163		-0.5700		-0.1298		*****		-0.7114
0.250		*****		-0.6059		-0.1757		-0.5825		-0.7250
0.300		-0.5146		-0.6229		-0.2311		-0.6186		-0.7373
0.350		*****		-0.6843		-0.3358		-0.6956		-0.7510
0.400		-0.5677		-0.7904		-0.4978		-0.7680		-0.7910
0.450		-0.7050		-0.9696		-0.6832		-0.8508		-0.8369
0.500		-1.0260		-1.1581		-0.9855		-0.8957		-0.8349
0.525		*****		-1.2568		-1.1091		-0.9008		-0.8448
0.550		-1.3659		-1.3654		-1.2078		-0.8879		-0.8069
0.575		*****		-1.4375		-1.2953		-0.8838		-0.7995
0.600		-1.5583		-1.4987		-1.3456		-0.8824		-0.7802
0.625		*****		*****		-1.2003		-0.8731		-0.7757
0.650		-1.6131		-1.3835		-1.0848		-0.9018		-0.7733
0.675		*****		-1.3628		-1.0461		-0.9124		-0.7564
0.700		-1.5185		-1.3369		-1.0288		-0.8696		-0.7526
0.725		*****		-1.3427		*****		-0.8453		-0.7499
0.750		-1.3768		-1.3438		*****		-0.8164		-0.7439
0.775		*****		-1.3770		-0.9986		-0.7983		-0.7348
0.800		-1.3022		-1.3838		-1.0189		-0.7758		*****
0.825		*****		-1.2988		-1.0069		-0.7610		-0.7059
0.850		-1.2895		-1.2156		-0.9105		-0.7534		-0.6771
0.875		*****		-1.2008		-0.8426		-0.7380		-0.6588
0.900		-1.2317		-1.2067		-0.8225		-0.7257		-0.6384
0.925		*****		-1.1906		-0.8206		-0.7065		-0.6340
0.950		-1.1925		-1.2266		-0.7939		-0.6939		-0.5795
0.975		*****		-1.1939		-0.7441		-0.6799		-0.5418
1.000		-1.3325		-1.2266		-0.7593		-0.6988		-0.5409
-0.200		$C_{p,l}$		0.5082		0.4739		*****		-0.4598
-0.400		0.5733		0.5161		0.4506		0.2493		-0.5201
-0.600		0.5801		0.5134		0.4449		0.2768		-0.4941
-0.700		0.5738		0.5118		0.4444		0.2907		-0.4646
-0.800		0.5413		*****		0.4381		0.3031		-0.3979
-0.850		*****		0.4798		0.4268		0.3074		-0.3907
-0.900		*****		0.4215		0.3873		0.2971		-0.3484
-0.950		0.2493		0.2649		0.2574		0.2168		-0.1293
-0.975		*****		0.0432		0.0695		0.0708		-0.1240
-1.000		-1.2611		-1.2288		-0.7328		-0.7230		-0.5988

Medium Radius L.E.
 Run No. = 28, Point No. = 571
 $C_N = 1.038$, $C_m = -0.1732$
 $\alpha = 22.7^\circ$, $M_\infty = 0.900$
 $R_{mac} = 59.6 \times 10^6$

Leading Edge Pressures

● starboard
 ○ port

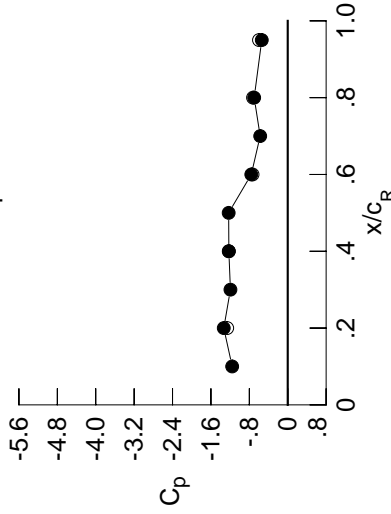

x/c_R	starb'd C_p	port C_p
0.10	-1.1572	*****
0.20	-1.3325	-1.2611
0.30	-1.1940	*****
0.40	-1.2266	-1.2288
0.50	-1.2306	*****
0.60	-0.7593	-0.7328
0.70	-0.5740	*****
0.80	-0.6988	-0.7230
0.90	*****	*****
0.95	-0.5409	-0.5988

Surface Pressures

● upper, starboard
 ○ lower, port

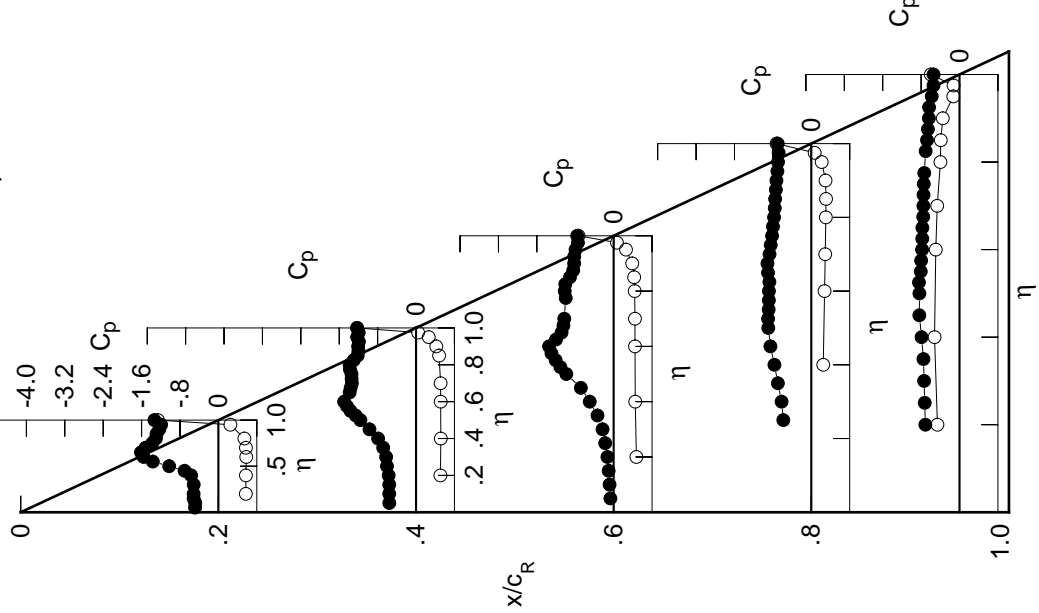
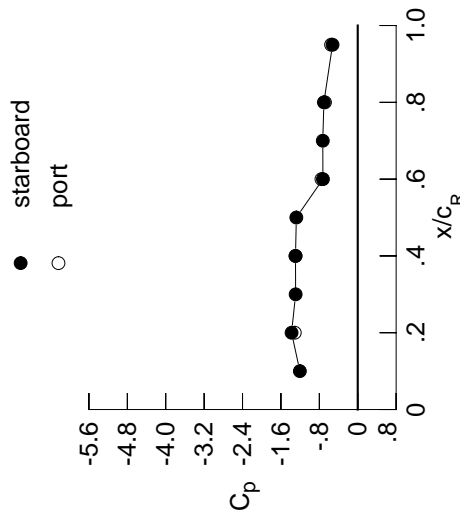

Table G4. Continued.

η	$x/c_R = .2$		$x/c_R = .4$		$x/c_R = .6$		$x/c_R = .8$		$x/c_R = .95$	
	$C_{p,u}$	$C_{p,u}$	$C_{p,u}$	$C_{p,u}$	$C_{p,u}$	$C_{p,u}$	$C_{p,u}$	$C_{p,u}$	$C_{p,u}$	$C_{p,u}$
0.050	-0.5676	-0.6400	-0.0903	*****	*****	*****	*****	*****	*****	*****
0.100	-0.5641	-0.6485	-0.1013	*****	*****	*****	*****	*****	*****	*****
0.150	-0.5721	-0.6551	-0.1174	*****	*****	*****	*****	*****	*****	*****
0.200	-0.5903	-0.6678	-0.1390	*****	*****	*****	*****	*****	*****	*****
0.250	*****	-0.6998	-0.1850	-0.8088	-0.8088	-0.6717	*****	*****	*****	*****
0.300	-0.6311	-0.7470	-0.2570	-0.8483	-0.7217	*****	*****	*****	*****	*****
0.350	*****	-0.8340	-0.3845	-0.9024	-0.7743	*****	*****	*****	*****	*****
0.400	-0.7947	-0.9640	-0.5814	-0.9389	-0.8583	*****	*****	*****	*****	*****
0.450	-1.0184	-1.1396	-0.7941	-0.9605	-0.8811	*****	*****	*****	*****	*****
0.500	-1.2996	-1.2959	-1.0623	-0.9292	-0.8231	*****	*****	*****	*****	*****
0.525	*****	-1.3727	-1.1622	-0.9072	-0.8154	*****	*****	*****	*****	*****
0.550	-1.5079	-1.4601	-1.2255	-0.8782	-0.7821	*****	*****	*****	*****	*****
0.575	-1.5153	-1.2598	-0.8792	-0.7846	*****	*****	*****	*****	*****	*****
0.600	-1.6278	-1.5585	-1.2406	-0.8898	-0.7818	*****	*****	*****	*****	*****
0.625	*****	*****	-1.1190	-0.8930	-0.7932	*****	*****	*****	*****	*****
0.650	-1.5278	-1.4087	-1.0234	-0.9123	-0.8005	*****	*****	*****	*****	*****
0.675	*****	-1.3633	-1.0139	-0.9347	-0.7891	*****	*****	*****	*****	*****
0.700	-1.5459	-1.3777	-1.0055	-0.9361	-0.7854	*****	*****	*****	*****	*****
0.725	*****	-1.3873	*****	-0.9305	-0.7774	*****	*****	*****	*****	*****
0.750	-1.4956	-1.3948	*****	-0.9024	-0.7664	*****	*****	*****	*****	*****
0.775	*****	-1.4332	-0.9765	-0.8884	-0.7573	*****	*****	*****	*****	*****
0.800	-1.3026	-1.4300	-0.9440	-0.8550	*****	*****	*****	*****	*****	*****
0.825	*****	-1.3559	-0.9226	-0.8418	-0.7178	*****	*****	*****	*****	*****
0.850	-1.3174	-1.2936	-0.8835	-0.8200	-0.6889	*****	*****	*****	*****	*****
0.875	*****	-1.2724	-0.8474	-0.7945	-0.6660	*****	*****	*****	*****	*****
0.900	-1.2672	-1.2728	-0.8131	-0.7760	-0.6440	*****	*****	*****	*****	*****
0.925	*****	-1.2792	-0.7815	-0.7530	-0.6350	*****	*****	*****	*****	*****
0.950	-1.2450	-1.2839	-0.7472	-0.7344	-0.5850	*****	*****	*****	*****	*****
0.975	*****	-1.2653	-0.7205	-0.7113	-0.5412	*****	*****	*****	*****	*****
1.000	-1.3786	-1.2964	-0.7249	-0.7050	-0.5247	*****	*****	*****	*****	*****
	$C_{p,l}$	$C_{p,l}$	$C_{p,l}$	$C_{p,l}$	$C_{p,l}$	$C_{p,l}$	$C_{p,l}$	$C_{p,l}$	$C_{p,l}$	$C_{p,l}$
-0.200	0.6286	0.5562	0.5110	*****	-0.4379	*****	*****	*****	*****	*****
-0.400	0.6290	0.5636	0.4890	0.2827	-0.5014	*****	*****	*****	*****	*****
-0.600	0.6306	0.5579	0.4809	0.3082	-0.4759	*****	*****	*****	*****	*****
-0.700	0.6172	0.5528	0.4790	0.3195	-0.4443	*****	*****	*****	*****	*****
-0.800	0.5720	*****	0.4672	0.3298	-0.3725	*****	*****	*****	*****	*****
-0.850	*****	0.5036	0.4503	0.3303	-0.3634	*****	*****	*****	*****	*****
-0.900	*****	0.4311	0.3999	0.3112	-0.3196	*****	*****	*****	*****	*****
-0.950	0.2330	0.2517	0.2479	0.2101	-0.1153	*****	*****	*****	*****	*****
-0.975	*****	0.0081	0.0420	0.0415	-0.1263	*****	*****	*****	*****	*****
-1.000	-1.3111	-1.2959	-0.7563	-0.6821	-0.5556	*****	*****	*****	*****	*****

Medium Radius L.E.
 Run No. = 28 , Point No. = 572
 $C_N = 1.133$, $C_m = -0.1861$
 $\alpha = 24.7^\circ$, $M_\infty = 0.893$
 $R_{mac} = 59.4 \times 10^6$

Leading Edge Pressures



x/c_R	starb'd C_p	port C_p
0.10	-1.2053	*****
0.20	-1.3786	-1.3111
0.30	-1.2938	*****
0.40	-1.2964	-1.2959
0.50	-1.2792	*****
0.60	-0.7249	-0.7563
0.70	-0.7283	*****
0.80	-0.7050	-0.6821
0.90	*****	*****
0.95	-0.5247	-0.5556

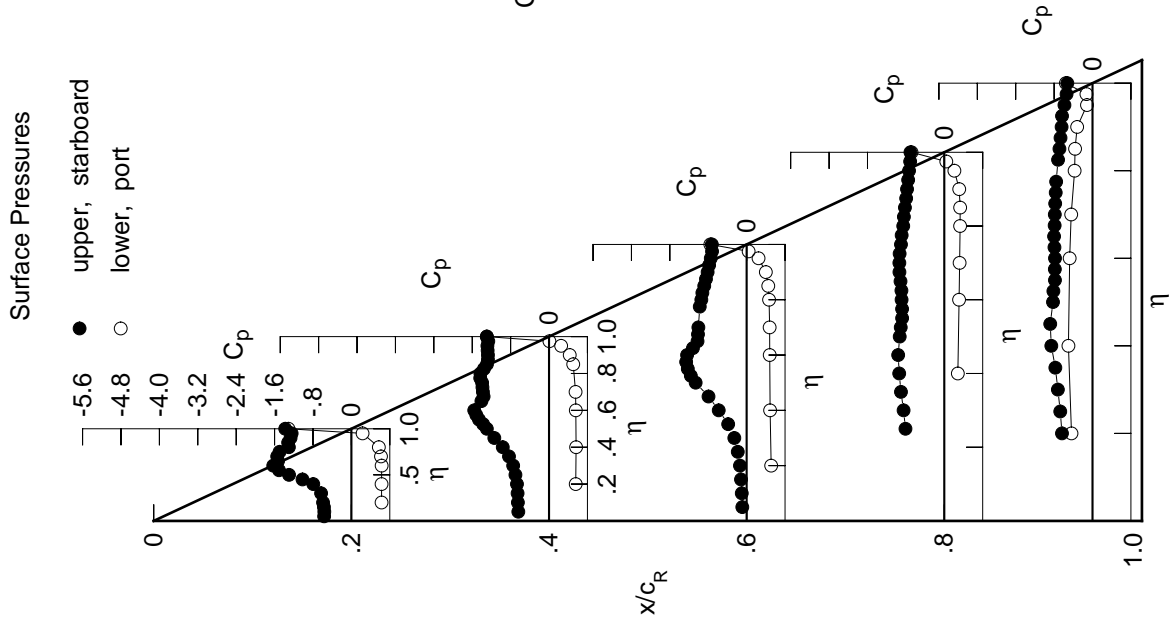
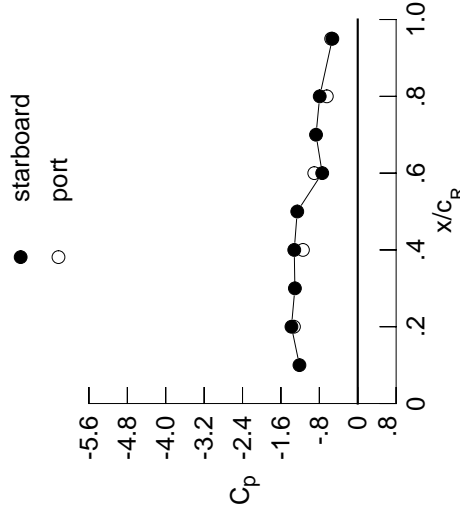

Table G4. Concluded.

η	x/c_R .2	x/c_R .4	x/c_R .6	x/c_R .8	x/c_R .95
	$C_{p,u}$	$C_{p,u}$	$C_{p,u}$	$C_{p,u}$	$C_{p,u}$
0.050	-0.6398	-0.6436	-0.4585	*****	*****
0.100	-0.6371	-0.6607	-0.4396	*****	*****
0.150	-0.6494	-0.6952	-0.4225	*****	*****
0.200	-0.6624	-0.7108	-0.4081	*****	-0.6219
0.250	*****	-0.7607	-0.4210	-0.9177	-0.6657
0.300	-0.7342	-0.8330	-0.4601	-0.9677	-0.7310
0.350	*****	-0.9406	-0.5584	-1.0244	-0.8013
0.400	-1.0023	-1.0793	-0.7133	-1.0579	-0.9016
0.450	-1.2266	-1.2401	-0.8743	-1.0574	-0.9140
0.500	-1.4235	-1.3623	-1.0902	-1.0014	-0.8362
0.525	*****	-1.4230	-1.1753	-0.9722	-0.8188
0.550	-1.5530	-1.4934	-1.2256	-0.9444	-0.7845
0.575	*****	-1.5344	-1.2305	-0.9433	-0.7834
0.600	-1.5483	-1.5331	-1.2136	-0.9471	-0.7825
0.625	*****	*****	-1.1438	-0.9402	-0.7991
0.650	-1.4867	-1.4155	-1.0693	-0.9472	-0.8131
0.675	*****	-1.3902	-1.0491	-0.9615	-0.8111
0.700	-1.5150	-1.3946	-1.0172	-0.9647	-0.8117
0.725	*****	-1.4037	*****	-0.9697	-0.8052
0.750	-1.5130	-1.4111	*****	-0.9511	-0.7850
0.775	*****	-1.4427	-0.9637	-0.9490	-0.7682
0.800	-1.3141	-1.4549	-0.9442	-0.9280	*****
0.825	*****	-1.4018	-0.9316	-0.9302	-0.7263
0.850	-1.3299	-1.3420	-0.9121	-0.9206	-0.6983
0.875	*****	-1.3104	-0.8921	-0.8999	-0.6742
0.900	-1.3009	-1.3059	-0.8524	-0.8803	-0.6500
0.925	*****	-1.3118	-0.8088	-0.8525	-0.6364
0.950	-1.2834	-1.3116	-0.7710	-0.8312	-0.5970
0.975	*****	-1.2990	-0.7468	-0.8046	-0.5574
1.000	-1.3810	-1.3225	-0.7397	-0.7922	-0.5285
	$C_{p,l}$	$C_{p,l}$	$C_{p,l}$	$C_{p,l}$	$C_{p,l}$
-0.200	0.6851	0.6064	0.5510	*****	-0.3985
-0.400	0.6852	0.6124	0.5287	0.3195	-0.4650
-0.600	0.6809	0.6038	0.5190	0.3431	-0.4404
-0.700	0.6607	0.5964	0.5155	0.3529	-0.4081
-0.800	0.6036	*****	0.4981	0.3596	-0.3382
-0.850	*****	0.5322	0.4753	0.3559	-0.3294
-0.900	*****	0.4477	0.4144	0.3288	-0.2876
-0.950	0.2278	0.2522	0.2441	0.2119	-0.1029
-0.975	*****	-0.0044	0.0230	0.0299	-0.1326
-1.000	-1.3289	-1.1412	-0.9057	-0.6440	-0.5536

Medium Radius L.E.
 Run No. = 28 , Point No. = 573
 $C_N = 1.185$, $C_m = -0.1935$
 $\alpha = 26.8^\circ$, $M_\infty = 0.901$
 $R_{mac} = 59.5 \times 10^6$

Leading Edge Pressures



x/c_R	starb'd C_p	port C_p
0.10	-1.2142	*****
0.20	-1.3810	-1.3289
0.30	-1.3092	*****
0.40	-1.3225	-1.1412
0.50	-1.2603	*****
0.60	-0.7397	-0.9057
0.70	-0.8687	*****
0.80	-0.7922	-0.6440
0.90	*****	*****
0.95	-0.5285	-0.5536

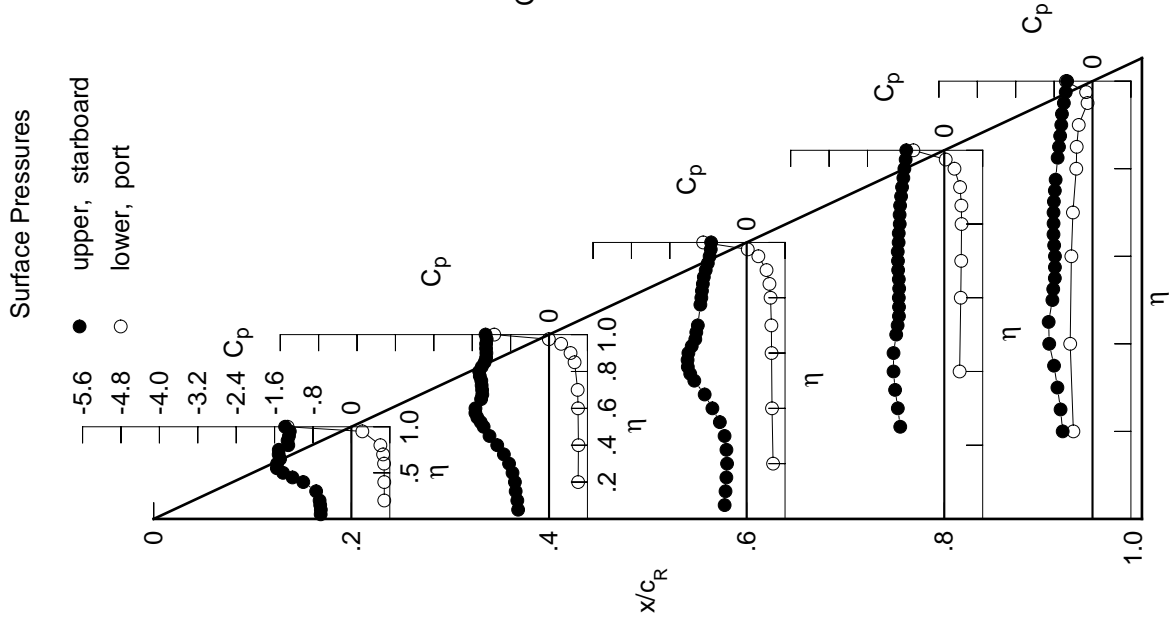

Appendix H

Experimental Surface Pressure Data for 65° Delta Wing, $R_{\text{mac}} = 120 \times 10^6$

The experimental surface pressure data for the 65° delta wing at constant $R_{\text{mac}} = 120 \times 10^6$ are summarized in tables H1–H4. Because of the extensive data contained in these tables, they have not been included in the printed copy of the paper but are available electronically from the Langley Technical Report Server (LTRS). Open the files with the following Uniform Resource Locator (URL):

<ftp://techreports.larc.nasa.gov/pub/techreports/larc/96/NASA-96-tm4645vol3appH.ps.Z>

Table H1. Tabulations and Plots of Surface Pressure Coefficients.

η	$x/c_R = .2$		$x/c_R = .4$		$x/c_R = .6$		$x/c_R = .8$		$x/c_R = .95$	
	$C_{p,u}$	$C_{p,l}$	$C_{p,u}$	$C_{p,l}$	$C_{p,u}$	$C_{p,l}$	$C_{p,u}$	$C_{p,l}$	$C_{p,u}$	$C_{p,l}$
0.050	0.0013	0.0163	0.1314	0.1314	0.1314	0.1314	0.1314	0.1314	0.1314	0.1314
0.100	0.0048	0.0174	0.1237	0.1237	0.1237	0.1237	0.1237	0.1237	0.1237	0.1237
0.150	0.0010	0.0158	0.1102	0.1102	0.1102	0.1102	0.1102	0.1102	0.1102	0.1102
0.200	0.0017	0.0213	0.0984	0.0984	0.0984	0.0984	0.0984	0.0984	0.0984	0.0984
0.250	0.0000	0.0158	0.0848	0.0848	0.0848	0.0848	0.0848	0.0848	0.0848	0.0848
0.300	-0.0080	0.0163	0.0754	0.0754	0.0754	0.0754	0.0754	0.0754	0.0754	0.0754
0.350	0.0000	0.0154	0.0650	0.0650	0.0650	0.0650	0.0650	0.0650	0.0650	0.0650
0.400	-0.0227	0.0135	0.0592	0.0592	0.0592	0.0592	0.0592	0.0592	0.0592	0.0592
0.450	-0.0285	0.0096	0.0693	0.0693	0.0693	0.0693	0.0693	0.0693	0.0693	0.0693
0.500	-0.0343	0.0096	0.0421	0.0657	0.0657	0.0657	0.0657	0.0657	0.0657	0.0657
0.525	0.0000	0.0047	0.0415	0.0668	0.0668	0.0668	0.0668	0.0668	0.0668	0.0668
0.550	-0.0315	-0.0007	0.0380	0.0613	0.0613	0.0613	0.0613	0.0613	0.0613	0.0613
0.575	0.0000	-0.0015	0.0443	0.0626	0.0626	0.0626	0.0626	0.0626	0.0626	0.0626
0.600	-0.0394	-0.0032	0.0285	0.0616	0.0616	0.0616	0.0616	0.0616	0.0616	0.0616
0.625	0.0000	0.0000	0.0301	0.0585	0.0585	0.0585	0.0585	0.0585	0.0585	0.0585
0.650	-0.0381	-0.0035	0.0262	0.0569	0.0569	0.0569	0.0569	0.0569	0.0569	0.0569
0.675	0.0000	-0.0166	0.0170	0.0604	0.0604	0.0604	0.0604	0.0604	0.0604	0.0604
0.700	-0.0315	-0.0248	0.0173	0.0578	0.0578	0.0578	0.0578	0.0578	0.0578	0.0578
0.725	0.0000	-0.0305	0.0000	0.0575	0.0575	0.0575	0.0575	0.0575	0.0575	0.0575
0.750	-0.0245	-0.0374	0.0000	0.0562	0.0562	0.0562	0.0562	0.0562	0.0562	0.0562
0.775	0.0000	-0.0398	-0.0053	0.0633	0.0633	0.0633	0.0633	0.0633	0.0633	0.0633
0.800	-0.0023	-0.0428	-0.0151	0.0681	0.0681	0.0681	0.0681	0.0681	0.0681	0.0681
0.825	0.0000	-0.0409	-0.0249	0.0634	0.0634	0.0634	0.0634	0.0634	0.0634	0.0634
0.850	0.0217	-0.0362	-0.0332	0.0835	0.0835	0.0835	0.0835	0.0835	0.0835	0.0835
0.875	0.0000	-0.0248	-0.0380	0.0919	0.0919	0.0919	0.0919	0.0919	0.0919	0.0919
0.900	0.0522	-0.0139	-0.0328	0.0979	0.0979	0.0979	0.0979	0.0979	0.0979	0.0979
0.925	0.0000	0.0110	-0.0206	0.0920	0.0920	0.0920	0.0920	0.0920	0.0920	0.0920
0.950	0.1037	0.0483	0.0120	0.0593	0.0593	0.0593	0.0593	0.0593	0.0593	0.0593
0.975	0.0000	0.1045	0.0698	0.0001	0.2079	0.2079	0.2079	0.2079	0.2079	0.2079
1.000	0.2209	0.2141	0.1869	0.1521	0.0925	0.0925	0.0925	0.0925	0.0925	0.0925
-0.200	-0.0272	-0.0048	0.0725	0.0000	-0.4365	-0.4365	-0.4365	-0.4365	-0.4365	-0.4365
-0.400	-0.0536	-0.0031	0.0320	0.0989	-0.4644	-0.4644	-0.4644	-0.4644	-0.4644	-0.4644
-0.600	-0.0782	-0.0301	0.0056	0.0843	-0.5347	-0.5347	-0.5347	-0.5347	-0.5347	-0.5347
-0.700	-0.0795	-0.0666	-0.0155	0.0854	-0.6242	-0.6242	-0.6242	-0.6242	-0.6242	-0.6242
-0.800	-0.0663	0.0000	-0.0671	0.0986	-0.6907	-0.6907	-0.6907	-0.6907	-0.6907	-0.6907
-0.850	0.0000	-0.1012	-0.0984	0.1297	-0.7349	-0.7349	-0.7349	-0.7349	-0.7349	-0.7349
-0.900	0.0000	-0.0894	-0.1156	0.1671	-0.5770	-0.5770	-0.5770	-0.5770	-0.5770	-0.5770
-0.950	0.0311	-0.0411	-0.0856	0.1609	-0.4230	-0.4230	-0.4230	-0.4230	-0.4230	-0.4230
-0.975	0.0000	0.0131	-0.0369	0.1082	-0.2877	-0.2877	-0.2877	-0.2877	-0.2877	-0.2877
-1.000	0.1838	0.1846	0.1393	0.1308	0.0735	0.0735	0.0735	0.0735	0.0735	0.0735

Medium Radius L.E.
 Run No. = 31, Point No. = 620
 $C_N = -0.037$, $C_m = 0.0086$
 $\alpha = -0.8^\circ$, $M_\infty = 0.798$
 $R_{mac} = 120.0 \times 10^6$

Surface Pressures

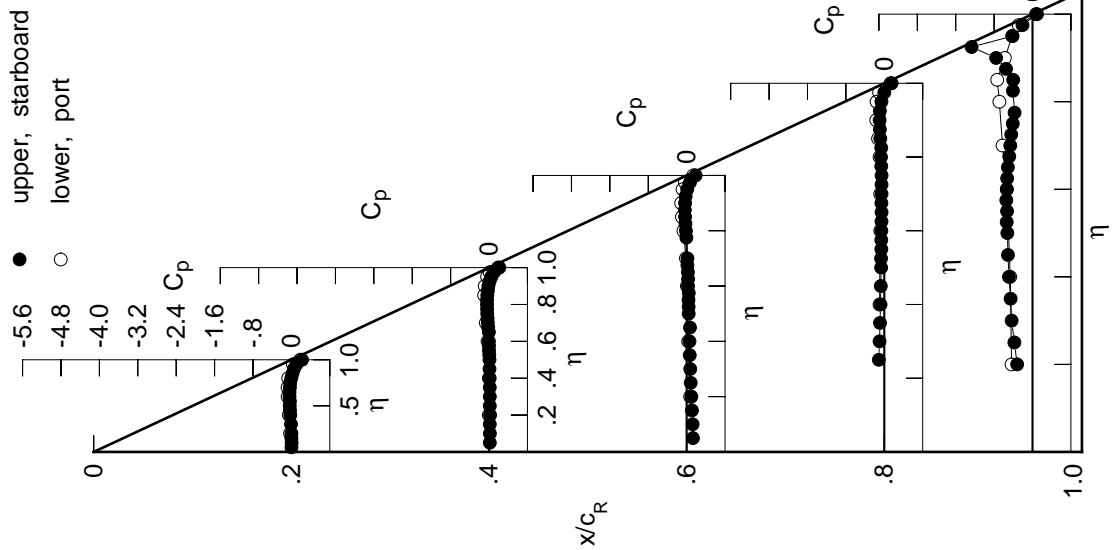

Leading Edge Pressures

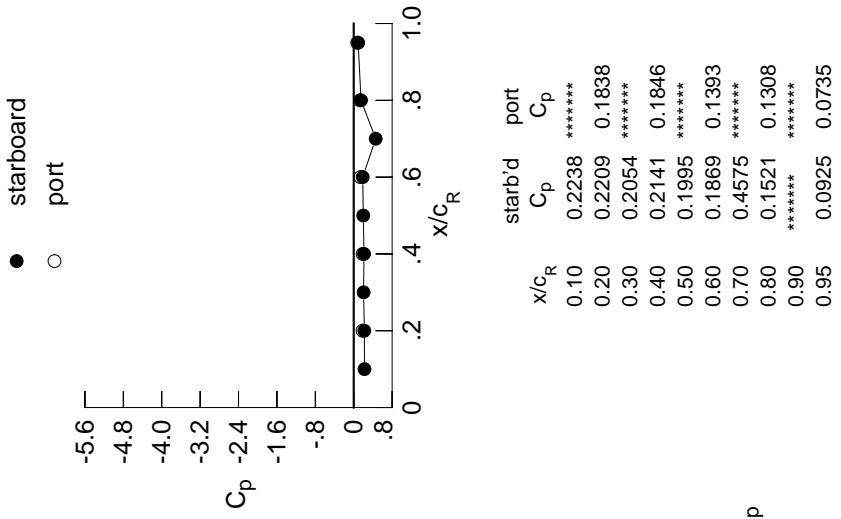
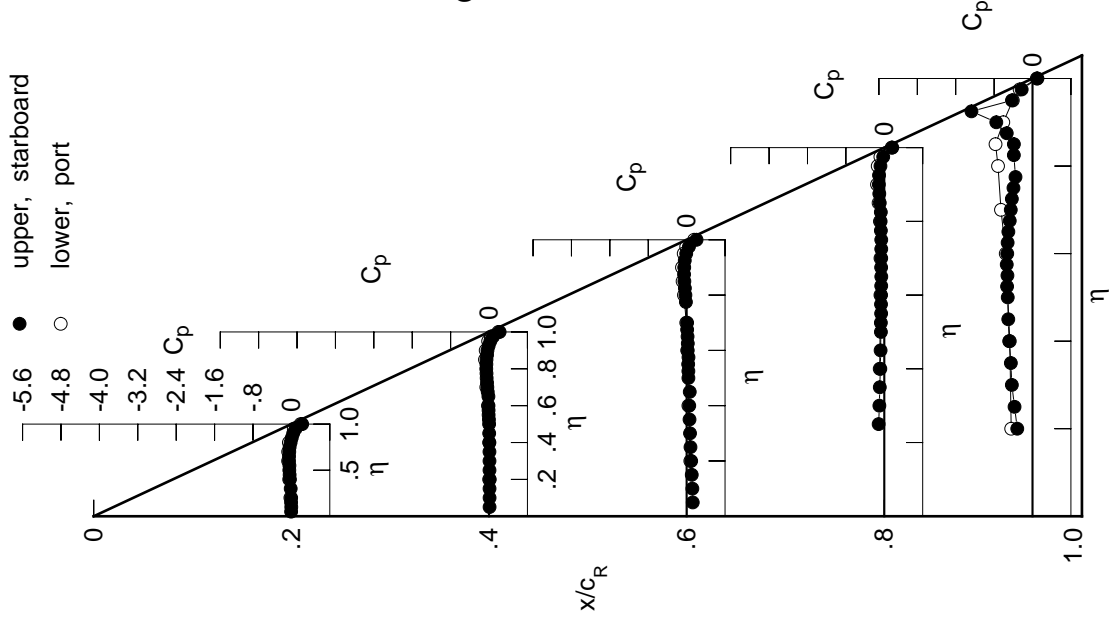

Table H1. Continued.

η	x/c_R .2	x/c_R .4	x/c_R .6	x/c_R .8	x/c_R .95
	$C_{p,u}$	$C_{p,u}$	$C_{p,u}$	$C_{p,u}$	$C_{p,u}$
0.050	-0.0057	0.0108	0.1274	*****	*****
0.100	-0.0023	0.0108	0.1195	*****	*****
0.150	-0.0063	0.0102	0.1060	*****	*****
0.200	-0.0052	0.0150	0.0943	*****	-0.3172
0.250	*****	0.0095	0.0802	-0.1172	-0.3741
0.300	-0.0144	0.0097	0.0707	-0.1027	-0.4308
0.350	*****	0.0089	0.0603	-0.0940	-0.4515
0.400	-0.0302	0.0069	0.0541	-0.0824	-0.4856
0.450	-0.0369	0.0029	0.0651	-0.0765	-0.5052
0.500	-0.0435	0.0020	0.0367	-0.0705	-0.5160
0.525	*****	-0.0023	0.0361	-0.0709	-0.5293
0.550	-0.0410	-0.0085	0.0320	-0.0660	-0.5225
0.575	*****	-0.0096	0.0386	-0.0677	-0.5369
0.600	-0.0496	-0.0113	0.0222	-0.0670	-0.5266
0.625	*****	*****	0.0239	-0.0639	-0.5185
0.650	-0.0491	-0.0126	0.0195	-0.0623	-0.5035
0.675	*****	-0.0269	0.0102	-0.0658	-0.4745
0.700	-0.0437	-0.0352	0.0098	-0.0637	-0.4527
0.725	*****	-0.0419	*****	-0.0635	-0.4305
0.750	-0.0371	-0.0498	*****	-0.0633	-0.3967
0.775	*****	-0.0526	-0.0150	-0.0713	-0.3544
0.800	-0.0160	-0.0575	-0.0259	-0.0763	*****
0.825	*****	-0.0555	-0.0371	-0.0718	-0.3888
0.850	0.0075	-0.0525	-0.0471	-0.0944	-0.3880
0.875	*****	-0.0418	-0.0535	-0.1044	-0.5371
0.900	0.0375	-0.0325	-0.0507	-0.1134	-0.7543
0.925	*****	-0.0079	-0.0390	-0.1094	-1.2722
0.950	0.0882	0.0274	-0.0089	-0.0798	-0.4280
0.975	*****	0.0839	0.0480	-0.0227	-0.2257
1.000	0.2247	0.2211	0.2065	0.1663	0.1025
	$C_{p,l}$	$C_{p,l}$	$C_{p,l}$	$C_{p,l}$	$C_{p,l}$
-0.200	-0.0206	0.0020	0.0765	*****	-0.4441
-0.400	-0.0458	0.0039	0.0371	-0.0953	-0.4733
-0.600	-0.0676	-0.0217	0.0116	-0.0801	-0.5576
-0.700	-0.0670	-0.0568	-0.0079	-0.0794	-0.6567
-0.800	-0.0517	*****	-0.0562	-0.0904	-0.7185
-0.850	*****	-0.0847	-0.0840	-0.1182	-0.7702
-0.900	*****	-0.0699	-0.0970	-0.1508	-0.6089
-0.950	0.0496	-0.0186	-0.0612	-0.1370	-0.4108
-0.975	*****	0.0385	-0.0091	-0.0805	-0.2676
-1.000	0.1910	0.1963	0.1558	0.1528	0.0899

Surface Pressures



Medium Radius L.E.
 Run No. = 31, Point No. = 621
 $C_N = -0.021$, $C_m = 0.0056$
 $\alpha = -0.4^\circ$, $M_\infty = 0.798$
 $R_{mac} = 120.1 \times 10^6$

Leading Edge Pressures

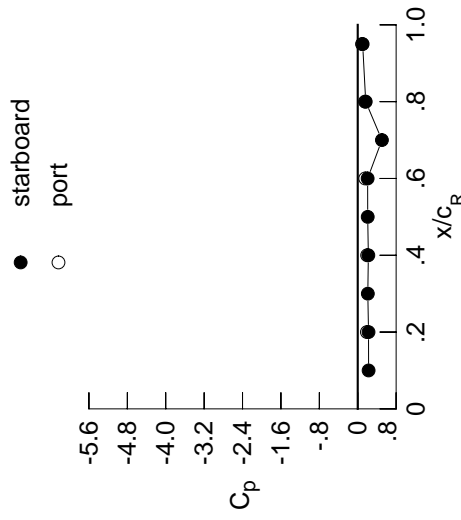

x/c_R	starb'd C_p	port C_p
0.10	0.2265	*****
0.20	0.2247	0.1910
0.30	0.2100	*****
0.40	0.2211	0.1963
0.50	0.2077	*****
0.60	0.2065	0.1558
0.70	0.5039	*****
0.80	0.1663	0.1528
0.90	*****	*****
0.95	0.1025	0.0899

Table H1. Continued.

η	$x/c_R = .2$		$x/c_R = .4$		$x/c_R = .6$		$x/c_R = .8$		$x/c_R = .95$	
	$C_{p,u}$	$C_{p,u}$	$C_{p,u}$	$C_{p,u}$	$C_{p,u}$	$C_{p,u}$	$C_{p,u}$	$C_{p,u}$	$C_{p,u}$	$C_{p,u}$
0.050	-0.0267	-0.0072	0.1156	*****	*****	*****	*****	*****	*****	*****
0.100	-0.0233	-0.0063	0.1070	*****	*****	*****	*****	*****	*****	*****
0.150	-0.0268	-0.0086	0.0939	*****	*****	*****	*****	*****	*****	*****
0.200	-0.0260	-0.0030	0.0811	*****	*****	*****	*****	*****	*****	*****
0.250	*****	-0.0093	0.0668	-0.1268	-0.1166	-0.1043	-0.4371	-0.4689	-0.3009	-0.3576
0.300	-0.0361	-0.0087	0.0577	-0.1116	-0.1043	-0.1043	-0.4371	-0.4689	-0.3009	-0.3576
0.350	*****	-0.0108	0.0463	-0.1043	-0.1043	-0.1043	-0.4371	-0.4689	-0.3009	-0.3576
0.400	-0.0537	-0.0129	0.0398	-0.0923	-0.0923	-0.0923	-0.4689	-0.4689	-0.3009	-0.3576
0.450	-0.0621	-0.0177	0.0492	-0.0875	-0.0875	-0.0875	-0.4847	-0.4847	-0.3009	-0.3576
0.500	-0.0700	-0.0193	0.0209	-0.0817	-0.0817	-0.0817	-0.4945	-0.4945	-0.3009	-0.3576
0.525	*****	-0.0243	0.0190	-0.0829	-0.0829	-0.0829	-0.5050	-0.5050	-0.3009	-0.3576
0.550	-0.0698	-0.0321	0.0153	-0.0793	-0.0793	-0.0793	-0.4987	-0.4987	-0.3009	-0.3576
0.575	*****	-0.0331	0.0208	-0.0803	-0.0803	-0.0803	-0.5106	-0.5106	-0.3009	-0.3576
0.600	-0.0807	-0.0371	0.0032	-0.0810	-0.0810	-0.0810	-0.5011	-0.5011	-0.3009	-0.3576
0.625	*****	*****	0.0049	-0.0774	-0.0774	-0.0774	-0.4921	-0.4921	-0.3009	-0.3576
0.650	-0.0825	-0.0382	-0.0007	-0.0765	-0.0765	-0.0765	-0.4766	-0.4766	-0.3009	-0.3576
0.675	*****	-0.0545	-0.0105	-0.0814	-0.0814	-0.0814	-0.4491	-0.4491	-0.3009	-0.3576
0.700	-0.0797	-0.0643	-0.0133	-0.0809	-0.0809	-0.0809	-0.4265	-0.4265	-0.3009	-0.3576
0.725	*****	-0.0737	*****	-0.0813	-0.0813	-0.0813	-0.4010	-0.4010	-0.3009	-0.3576
0.750	-0.0757	-0.0831	*****	-0.0839	-0.0839	-0.0839	-0.3585	-0.3585	-0.3009	-0.3576
0.775	*****	-0.0907	-0.0435	-0.0924	-0.0924	-0.0924	-0.3060	-0.3060	-0.3009	-0.3576
0.800	-0.0576	-0.0972	-0.0577	-0.1014	-0.1014	-0.1014	*****	*****	-0.3009	-0.3576
0.825	*****	-0.0998	-0.0730	-0.0981	-0.0981	-0.0981	-0.3346	-0.3346	-0.3009	-0.3576
0.850	-0.0365	-0.0992	-0.0885	-0.1264	-0.1264	-0.1264	-0.3501	-0.3501	-0.3009	-0.3576
0.875	*****	-0.0933	-0.1000	-0.1426	-0.1426	-0.1426	-0.4874	-0.4874	-0.3009	-0.3576
0.900	-0.0100	-0.0869	-0.1040	-0.1604	-0.1604	-0.1604	-0.7126	-0.7126	-0.3009	-0.3576
0.925	*****	-0.0678	-0.0991	-0.1636	-0.1636	-0.1636	-1.2727	-1.2727	-0.3009	-0.3576
0.950	0.0378	-0.0360	-0.0764	-0.1444	-0.1444	-0.1444	-0.4663	-0.4663	-0.3009	-0.3576
0.975	*****	0.0167	-0.0251	-0.0970	-0.0970	-0.0970	-0.2816	-0.2816	-0.3009	-0.3576
1.000	0.2189	0.2105	0.2017	0.1568	0.1568	0.1568	0.0999	0.0999	0.0999	0.1010
-0.200	$C_{p,l}$	$C_{p,l}$	$C_{p,l}$	$C_{p,l}$	$C_{p,l}$	$C_{p,l}$	$C_{p,l}$	$C_{p,l}$	$C_{p,l}$	$C_{p,l}$
-0.400	0.0008	0.0196	0.0897	*****	*****	*****	-0.4447	-0.4447	-0.4447	-0.4447
-0.600	-0.0214	0.0234	0.0528	-0.0840	-0.0840	-0.0840	-0.4942	-0.4942	-0.4942	-0.4942
-0.700	-0.0372	0.0021	0.0302	-0.0652	-0.0652	-0.0652	-0.5955	-0.5955	-0.5955	-0.5955
-0.800	-0.0313	-0.0262	0.0148	-0.0620	-0.0620	-0.0620	-0.7072	-0.7072	-0.7072	-0.7072
-0.850	-0.0093	*****	-0.0248	-0.0660	-0.0660	-0.0660	-0.7261	-0.7261	-0.7261	-0.7261
-0.900	*****	-0.0381	-0.0439	-0.0864	-0.0864	-0.0864	-0.7671	-0.7671	-0.7671	-0.7671
-0.950	*****	-0.0160	-0.0462	-0.1060	-0.1060	-0.1060	-0.7802	-0.7802	-0.7802	-0.7802
-0.975	0.0989	0.0419	0.0022	-0.0751	-0.0751	-0.0751	-0.3783	-0.3783	-0.3783	-0.3783
-1.000	*****	0.1034	0.0609	-0.1012	-0.1012	-0.1012	-0.2163	-0.2163	-0.2163	-0.2163
-1.000	0.1912	0.1953	0.1570	0.1609	0.1609	0.1609	0.1010	0.1010	0.1010	0.1010

Medium Radius L.E.
 Run No. = 31, Point No. = 622
 $C_N = 0.018$, $C_m = 0.0002$
 $\alpha = 0.6^\circ$, $M_\infty = 0.797$
 $R_{mac} = 120.0 \times 10^6$

Leading Edge Pressures

● starboard
 ○ port

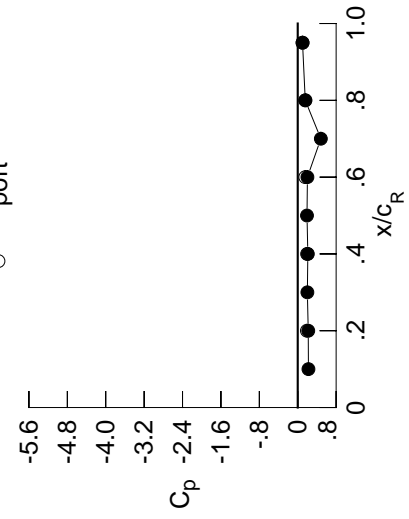

x/c_R	starb'd C_p	port C_p
0.10	0.2230	*****
0.20	0.2189	0.1912
0.30	0.2006	*****
0.40	0.2105	0.1953
0.50	0.1932	*****
0.60	0.2017	0.1570
0.70	0.4813	*****
0.80	0.1568	0.1609
0.90	*****	*****
0.95	0.0999	0.1010

Surface Pressures

● upper, starboard
 ○ lower, port

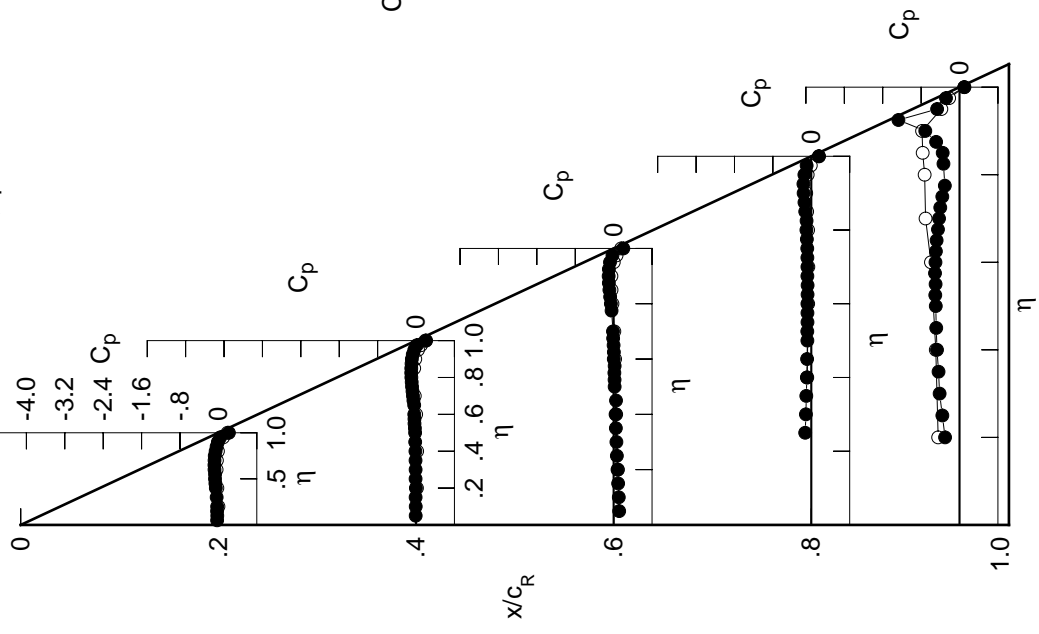

Table H1. Continued.

η	$x/c_R = .2$		$x/c_R = .4$		$x/c_R = .6$		$x/c_R = .8$		$x/c_R = .95$	
	$C_{p,u}$	$C_{p,u}$	$C_{p,u}$	$C_{p,u}$	$C_{p,u}$	$C_{p,u}$	$C_{p,u}$	$C_{p,u}$	$C_{p,u}$	$C_{p,u}$
0.050	-0.0477	-0.0249	0.1027	*****	*****	*****	*****	*****	*****	*****
0.100	-0.0448	-0.0250	0.0937	*****	*****	*****	*****	*****	*****	*****
0.150	-0.0479	-0.0267	0.0805	*****	*****	*****	*****	*****	*****	*****
0.200	-0.0475	-0.0216	0.0677	*****	*****	*****	*****	*****	*****	-0.2937
0.250	*****	-0.0280	0.0529	-0.1376	-0.3456	*****	*****	*****	*****	-0.3456
0.300	-0.0582	-0.0276	0.0437	-0.1226	-0.4013	*****	*****	*****	*****	-0.4013
0.350	*****	-0.0308	0.0310	-0.1158	-0.4229	*****	*****	*****	*****	-0.4229
0.400	-0.0785	-0.0332	0.0250	-0.1038	-0.4536	*****	*****	*****	*****	-0.4536
0.450	-0.0882	-0.0391	0.0325	-0.1000	-0.4672	*****	*****	*****	*****	-0.4672
0.500	-0.0982	-0.0416	0.0042	-0.0949	-0.4757	*****	*****	*****	*****	-0.4757
0.525	*****	-0.0471	0.0011	-0.0961	-0.4841	*****	*****	*****	*****	-0.4841
0.550	-0.0997	-0.0560	-0.0027	-0.0934	-0.4780	*****	*****	*****	*****	-0.4780
0.575	*****	-0.0579	0.0014	-0.0944	-0.4877	*****	*****	*****	*****	-0.4877
0.600	-0.1134	-0.0626	-0.0162	-0.0964	-0.4794	*****	*****	*****	*****	-0.4794
0.625	*****	*****	-0.0161	-0.0936	-0.4717	*****	*****	*****	*****	-0.4717
0.650	-0.1179	-0.0663	-0.0217	-0.0936	-0.4572	*****	*****	*****	*****	-0.4572
0.675	*****	-0.0839	-0.0333	-0.0992	-0.4298	*****	*****	*****	*****	-0.4298
0.700	-0.1180	-0.0968	-0.0377	-0.1001	-0.4066	*****	*****	*****	*****	-0.4066
0.725	*****	-0.1088	*****	-0.1014	-0.3765	*****	*****	*****	*****	-0.3765
0.750	-0.1172	-0.1204	*****	-0.1059	-0.3280	*****	*****	*****	*****	-0.3280
0.775	*****	-0.1315	-0.0745	-0.1164	-0.2667	*****	*****	*****	*****	-0.2667
0.800	-0.1032	-0.1417	-0.0923	-0.1286	*****	*****	*****	*****	*****	*****
0.825	*****	-0.1491	-0.1127	-0.1269	-0.2921	*****	*****	*****	*****	-0.2921
0.850	-0.0854	-0.1526	-0.1347	-0.1610	-0.3199	*****	*****	*****	*****	-0.3199
0.875	*****	-0.1518	-0.1522	-0.1848	-0.4527	*****	*****	*****	*****	-0.4527
0.900	-0.0645	-0.1502	-0.1649	-0.2115	-0.6703	*****	*****	*****	*****	-0.6703
0.925	*****	-0.1372	-0.1679	-0.2255	-1.2158	*****	*****	*****	*****	-1.2158
0.950	-0.0228	-0.1111	-0.1561	-0.2194	-0.5083	*****	*****	*****	*****	-0.5083
0.975	*****	-0.0714	-0.1175	-0.1883	-0.3501	*****	*****	*****	*****	-0.3501
1.000	0.1816	0.1465	0.1196	0.0688	0.0428	*****	*****	*****	*****	0.0428
-0.200	$C_{p,l}$	$C_{p,l}$	$C_{p,l}$	$C_{p,l}$	$C_{p,l}$	$C_{p,l}$	$C_{p,l}$	$C_{p,l}$	$C_{p,l}$	$C_{p,l}$
-0.400	0.0223	0.0378	0.1027	*****	-0.4581	*****	*****	*****	*****	-0.4581
-0.600	0.0024	0.0431	0.0679	-0.0724	-0.5218	*****	*****	*****	*****	-0.5218
-0.700	-0.0067	0.0263	0.0483	-0.0508	-0.6585	*****	*****	*****	*****	-0.6585
-0.800	0.0036	0.0029	0.0382	-0.0443	-0.7372	*****	*****	*****	*****	-0.7372
-0.850	0.0292	*****	0.0062	-0.0423	-0.7155	*****	*****	*****	*****	-0.7155
-0.900	*****	0.0054	-0.0049	-0.0555	-0.7474	*****	*****	*****	*****	-0.7474
-0.950	*****	0.0338	0.0020	-0.0627	-0.7985	*****	*****	*****	*****	-0.7985
-0.975	0.1417	0.0933	0.0577	-0.0186	-0.3455	*****	*****	*****	*****	-0.3455
-1.000	0.1567	0.1414	0.0837	0.0879	0.0557	*****	*****	*****	*****	0.0557

Medium Radius L.E.
 Run No. = 31, Point No. = 623
 $C_N = 0.059$, $C_m = -0.0051$
 $\alpha = 1.7^\circ$, $M_\infty = 0.799$
 $R_{mac} = 120.0 \times 10^6$

Leading Edge Pressures

● starboard
 ○ port

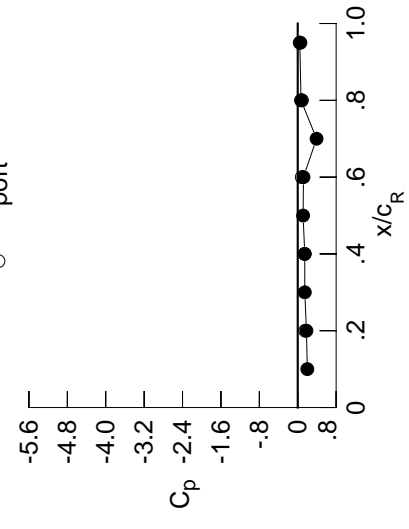

x/c_R	starb'd C_p	port C_p
0.10	0.1996	*****
0.20	0.1816	0.1567
0.30	0.1468	*****
0.40	0.1465	0.1414
0.50	0.1118	*****
0.60	0.1196	0.0837
0.70	0.3919	*****
0.80	0.0688	0.0879
0.90	*****	*****
0.95	0.0428	0.0557

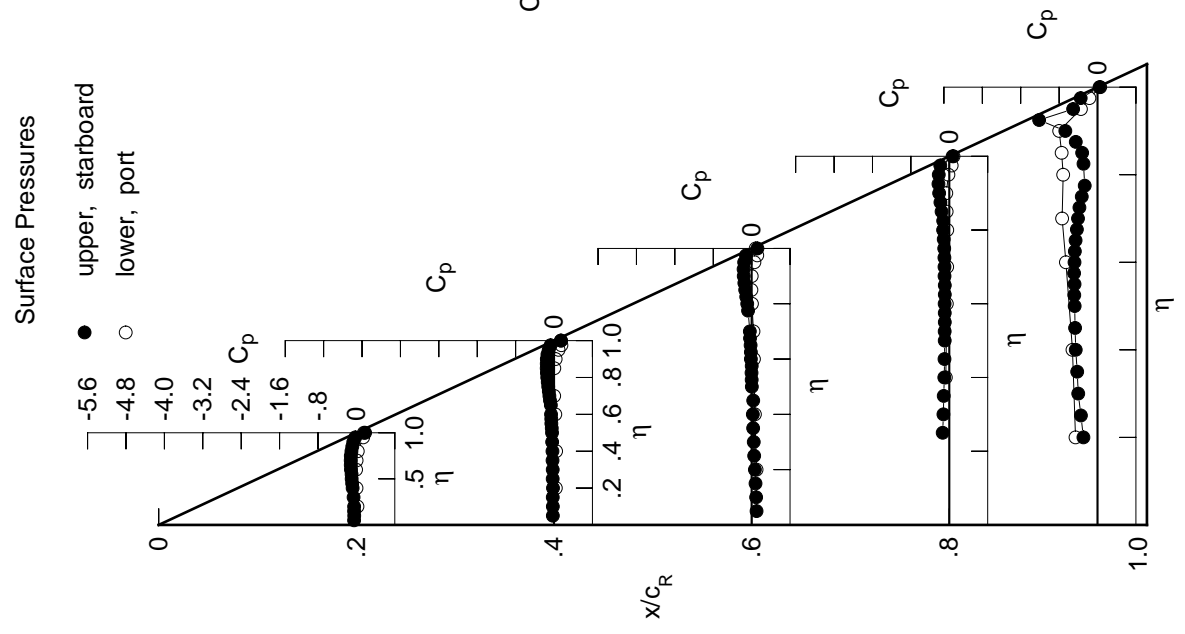
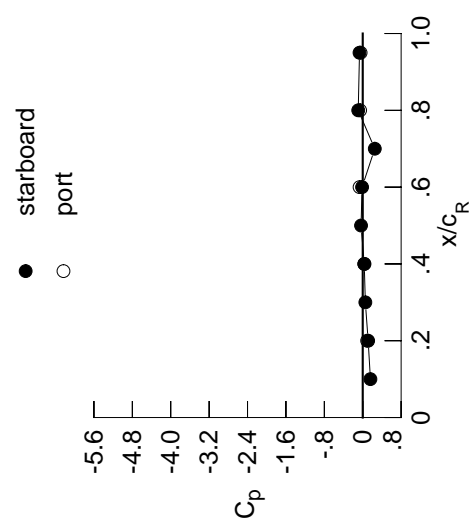

Table H1. Continued.

η	$x/c_R = .2$		$x/c_R = .4$		$x/c_R = .6$		$x/c_R = .8$		$x/c_R = .95$	
	$C_{p,u}$	$C_{p,l}$	$C_{p,u}$	$C_{p,l}$	$C_{p,u}$	$C_{p,l}$	$C_{p,u}$	$C_{p,l}$	$C_{p,u}$	$C_{p,l}$
0.050	-0.0670	-0.0419	0.0918	*****	*****	*****	*****	*****	*****	*****
0.100	-0.0641	-0.0417	0.0824	*****	*****	*****	*****	*****	*****	*****
0.150	-0.0668	-0.0441	0.0692	*****	*****	*****	*****	*****	*****	*****
0.200	-0.0678	-0.0386	0.0557	*****	*****	*****	*****	*****	*****	-0.2909
0.250	*****	-0.0458	0.0413	-0.1469	-0.1318	-0.3892	*****	*****	*****	-0.3382
0.300	-0.0789	-0.0455	0.0313	-0.1318	-0.1251	-0.4083	*****	*****	*****	-0.3892
0.350	*****	-0.0494	0.0181	-0.1251	-0.1138	-0.4366	*****	*****	*****	-0.4083
0.400	-0.1022	-0.0520	0.0108	-0.1138	-0.1103	-0.4494	*****	*****	*****	-0.4366
0.450	-0.1127	-0.0593	0.0184	-0.1103	-0.1060	-0.4580	*****	*****	*****	-0.4494
0.500	-0.1247	-0.0630	-0.0114	-0.1060	-0.1079	-0.4650	*****	*****	*****	-0.4580
0.525	*****	-0.0695	-0.0150	-0.1079	-0.1055	-0.4603	*****	*****	*****	-0.4650
0.550	-0.1288	-0.0793	-0.0200	-0.1055	-0.1071	-0.4696	*****	*****	*****	-0.4603
0.575	*****	-0.0818	-0.0159	-0.1071	-0.1097	-0.4625	*****	*****	*****	-0.4696
0.600	-0.1451	-0.0882	-0.0344	-0.1097	-0.1079	-0.4557	*****	*****	*****	-0.4625
0.625	*****	*****	-0.0349	-0.1079	-0.1169	-0.3912	*****	*****	*****	-0.4557
0.650	-0.1532	-0.0927	-0.0421	-0.1090	-0.1155	-0.4152	*****	*****	*****	-0.3912
0.675	*****	-0.1127	-0.0547	-0.1155	-0.1203	-0.3587	*****	*****	*****	-0.4152
0.700	-0.1563	-0.1279	-0.0610	-0.1169	-0.1265	-0.3068	*****	*****	*****	-0.3587
0.725	*****	-0.1427	*****	-0.1203	-0.1285	-0.3068	*****	*****	*****	-0.3068
0.750	-0.1596	-0.1577	*****	-0.1265	-0.1394	-0.2410	*****	*****	*****	-0.3068
0.775	*****	-0.1726	-0.1050	-0.1394	-0.1546	*****	*****	*****	*****	-0.2410
0.800	-0.1497	-0.1869	-0.1271	-0.1546	-0.1558	-0.2644	*****	*****	*****	*****
0.825	*****	-0.1990	-0.1530	-0.1558	-0.1957	-0.2956	*****	*****	*****	-0.2644
0.850	-0.1370	-0.2070	-0.1811	-0.1957	-0.2280	-0.4202	*****	*****	*****	-0.2956
0.875	*****	-0.2117	-0.2068	-0.2280	-0.2657	-0.6055	*****	*****	*****	-0.4202
0.900	-0.1224	-0.2164	-0.2284	-0.2657	-0.2921	-0.9906	*****	*****	*****	-0.6055
0.925	*****	-0.2123	-0.2419	-0.2921	-0.3014	-0.5536	*****	*****	*****	-0.9906
0.950	-0.0894	-0.1945	-0.2436	-0.3014	-0.2924	-0.4256	*****	*****	*****	-0.5536
0.975	*****	-0.1727	-0.2248	-0.2924	-0.0936	-0.0673	*****	*****	*****	-0.4256
1.000	0.1130	0.0315	-0.0136	-0.0936	-0.0673	*****	*****	*****	*****	-0.0673
-0.200	$C_{p,l}$	$C_{p,l}$	$C_{p,l}$	$C_{p,l}$	$C_{p,l}$	$C_{p,l}$	$C_{p,l}$	$C_{p,l}$	$C_{p,l}$	$C_{p,l}$
-0.400	0.0449	0.0569	0.1174	*****	-0.4627	*****	*****	*****	*****	-0.4627
-0.600	0.0275	0.0638	0.0841	-0.0600	-0.5494	*****	*****	*****	*****	-0.5494
-0.700	0.0238	0.0503	0.0679	-0.0352	-0.6983	*****	*****	*****	*****	-0.6983
-0.800	0.0379	0.0325	0.0609	-0.0264	-0.7423	*****	*****	*****	*****	-0.7423
-0.850	0.0669	*****	0.0360	-0.0193	-0.7015	*****	*****	*****	*****	-0.7015
-0.900	*****	0.0466	0.0313	-0.0258	-0.7268	*****	*****	*****	*****	-0.7268
-0.950	*****	0.0783	0.0457	-0.0228	-0.7635	*****	*****	*****	*****	-0.7635
-0.975	0.1765	0.1366	0.1045	0.0292	-0.3157	*****	*****	*****	*****	-0.3157
-1.000	*****	0.1894	0.1590	0.0953	-0.1296	*****	*****	*****	*****	-0.1296
	0.0921	0.0357	-0.0655	-0.0542	-0.0443	*****	*****	*****	*****	-0.0443

Medium Radius L.E.
 Run No. = 31, Point No. = 624
 $C_N = 0.099$, $C_m = -0.0103$
 $\alpha = 2.8^\circ$, $M_\infty = 0.798$
 $R_{mac} = 120.1 \times 10^6$

Leading Edge Pressures



x/c_R	starb'd C_p	port C_p
0.10	0.1603	*****
0.20	0.1130	0.0921
0.30	0.0545	*****
0.40	0.0315	0.0357
0.50	-0.0348	*****
0.60	-0.0136	-0.0655
0.70	0.2509	*****
0.80	-0.0936	-0.0542
0.90	*****	*****
0.95	-0.0673	-0.0443

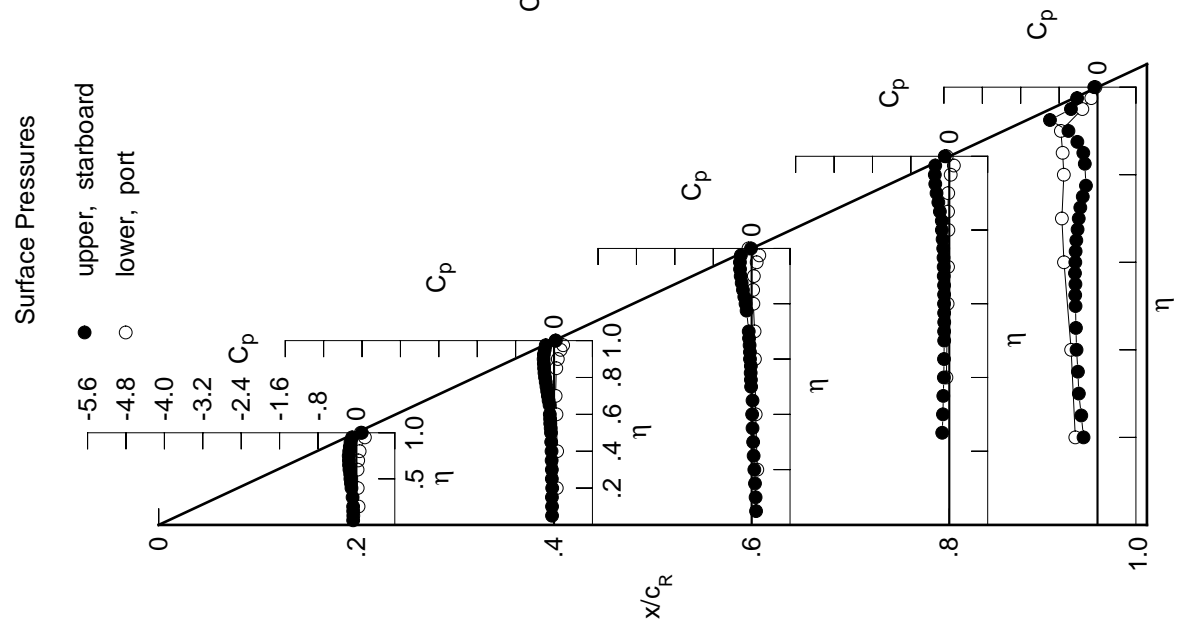
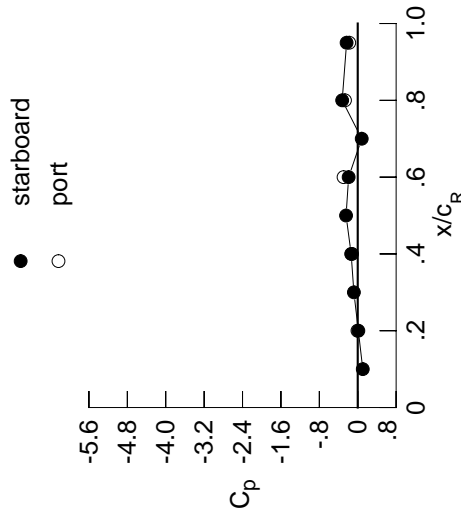

Table H1. Continued.

η	$x/c_R = .2$		$x/c_R = .4$		$x/c_R = .6$		$x/c_R = .8$		$x/c_R = .95$	
	$C_{p,u}$	$C_{p,u}$	$C_{p,u}$	$C_{p,u}$	$C_{p,u}$	$C_{p,u}$	$C_{p,u}$	$C_{p,u}$	$C_{p,u}$	$C_{p,u}$
0.050	-0.0859	-0.0583	0.0800	0.0800	0.0800	0.0800	0.0800	0.0800	0.0800	0.0800
0.100	-0.0837	-0.0579	0.0710	0.0710	0.0710	0.0710	0.0710	0.0710	0.0710	0.0710
0.150	-0.0870	-0.0602	0.0570	0.0570	0.0570	0.0570	0.0570	0.0570	0.0570	0.0570
0.200	-0.0878	-0.0558	0.0443	0.0443	0.0443	0.0443	0.0443	0.0443	0.0443	0.0443
0.250	0.0000	-0.0625	0.0287	0.0287	0.0287	0.0287	0.0287	0.0287	0.0287	0.0287
0.300	-0.0992	-0.0634	0.0189	0.0189	0.0189	0.0189	0.0189	0.0189	0.0189	0.0189
0.350	0.0000	-0.0673	0.0049	0.0049	0.0049	0.0049	0.0049	0.0049	0.0049	0.0049
0.400	-0.1250	-0.0715	-0.0038	-0.0038	-0.0038	-0.0038	-0.0038	-0.0038	-0.0038	-0.0038
0.450	-0.1371	-0.0790	0.0037	0.0037	0.0037	0.0037	0.0037	0.0037	0.0037	0.0037
0.500	-0.1507	-0.0840	-0.0277	-0.0277	-0.0277	-0.0277	-0.0277	-0.0277	-0.0277	-0.0277
0.525	0.0000	-0.0911	-0.0314	-0.0314	-0.0314	-0.0314	-0.0314	-0.0314	-0.0314	-0.0314
0.550	-0.1576	-0.1015	-0.0372	-0.0372	-0.0372	-0.0372	-0.0372	-0.0372	-0.0372	-0.0372
0.575	0.0000	-0.1055	-0.0338	-0.0338	-0.0338	-0.0338	-0.0338	-0.0338	-0.0338	-0.0338
0.600	-0.1763	-0.1126	-0.0541	-0.0541	-0.0541	-0.0541	-0.0541	-0.0541	-0.0541	-0.0541
0.625	0.0000	0.0000	-0.0552	-0.0552	-0.0552	-0.0552	-0.0552	-0.0552	-0.0552	-0.0552
0.650	-0.1874	-0.1207	-0.0632	-0.0632	-0.0632	-0.0632	-0.0632	-0.0632	-0.0632	-0.0632
0.675	0.0000	-0.1422	-0.0772	-0.0772	-0.0772	-0.0772	-0.0772	-0.0772	-0.0772	-0.0772
0.700	-0.1943	-0.1594	-0.0846	-0.0846	-0.0846	-0.0846	-0.0846	-0.0846	-0.0846	-0.0846
0.725	0.0000	-0.1773	0.0000	0.0000	-0.1408	-0.1408	-0.1408	-0.1408	-0.1408	-0.1408
0.750	-0.2019	-0.1961	0.0000	0.0000	-0.1480	-0.1480	-0.1480	-0.1480	-0.1480	-0.1480
0.775	0.0000	-0.2139	-0.1360	-0.1360	-0.1638	-0.1638	-0.1638	-0.1638	-0.1638	-0.1638
0.800	-0.1966	-0.2336	-0.1627	-0.1627	-0.1817	-0.1817	-0.1817	-0.1817	-0.1817	-0.1817
0.825	0.0000	-0.2505	-0.1940	-0.1940	-0.1853	-0.1853	-0.1853	-0.1853	-0.1853	-0.1853
0.850	-0.1905	-0.2649	-0.2288	-0.2288	-0.2319	-0.2319	-0.2319	-0.2319	-0.2319	-0.2319
0.875	0.0000	-0.2757	-0.2632	-0.2632	-0.2724	-0.2724	-0.2724	-0.2724	-0.2724	-0.2724
0.900	-0.1840	-0.2872	-0.2949	-0.2949	-0.3211	-0.3211	-0.3211	-0.3211	-0.3211	-0.3211
0.925	0.0000	-0.2926	-0.3207	-0.3207	-0.3612	-0.3612	-0.3612	-0.3612	-0.3612	-0.3612
0.950	-0.1621	-0.2862	-0.3388	-0.3388	-0.3893	-0.3893	-0.3893	-0.3893	-0.3893	-0.3893
0.975	0.0000	-0.2885	-0.3460	-0.3460	-0.4094	-0.4094	-0.4094	-0.4094	-0.4094	-0.4094
1.000	0.0127	-0.1368	-0.1897	-0.1897	-0.3238	-0.3238	-0.3238	-0.3238	-0.3238	-0.3238
-0.200	$C_{p,l}$	0.0657	0.0752	0.1305	0.1305	0.1305	0.1305	0.1305	0.1305	0.1305
-0.400	$C_{p,l}$	0.0516	0.0828	0.0983	0.0983	0.0983	0.0983	0.0983	0.0983	0.0983
-0.600	$C_{p,l}$	0.0526	0.0733	0.0852	0.0852	0.0852	0.0852	0.0852	0.0852	0.0852
-0.700	$C_{p,l}$	0.0695	0.0588	0.0806	0.0806	0.0806	0.0806	0.0806	0.0806	0.0806
-0.800	$C_{p,l}$	0.1007	0.0000	0.0627	0.0627	0.0627	0.0627	0.0627	0.0627	0.0627
-0.850	$C_{p,l}$	0.0832	0.0832	0.0642	0.0642	0.0642	0.0642	0.0642	0.0642	0.0642
-0.900	$C_{p,l}$	0.2036	0.1700	0.1412	0.1412	0.1412	0.1412	0.1412	0.1412	0.1412
-0.950	$C_{p,l}$	0.2036	0.2100	0.1851	0.1851	0.1851	0.1851	0.1851	0.1851	0.1851
-0.975	$C_{p,l}$	0.2036	0.2100	0.1851	0.1851	0.1851	0.1851	0.1851	0.1851	0.1851
-1.000	$C_{p,l}$	-0.0052	-0.1190	-0.2949	-0.2949	-0.2656	-0.2656	-0.2656	-0.2656	-0.2656

Medium Radius L.E.
 Run No. = 31, Point No. = 625
 $C_N = 0.138$, $C_m = -0.0155$
 $\alpha = 3.9^\circ$, $M_\infty = 0.799$
 $R_{mac} = 120.0 \times 10^6$

Leading Edge Pressures



x/c_R	starb'd C_p	port C_p
0.10	0.1052	0.1052
0.20	0.0127	0.0127
0.30	-0.0802	-0.0802
0.40	-0.1368	-0.1368
0.50	-0.2430	-0.2430
0.60	-0.1897	-0.1897
0.70	0.0832	0.0832
0.80	-0.3238	-0.3238
0.90	0.0000	0.0000
0.95	-0.2320	-0.2320

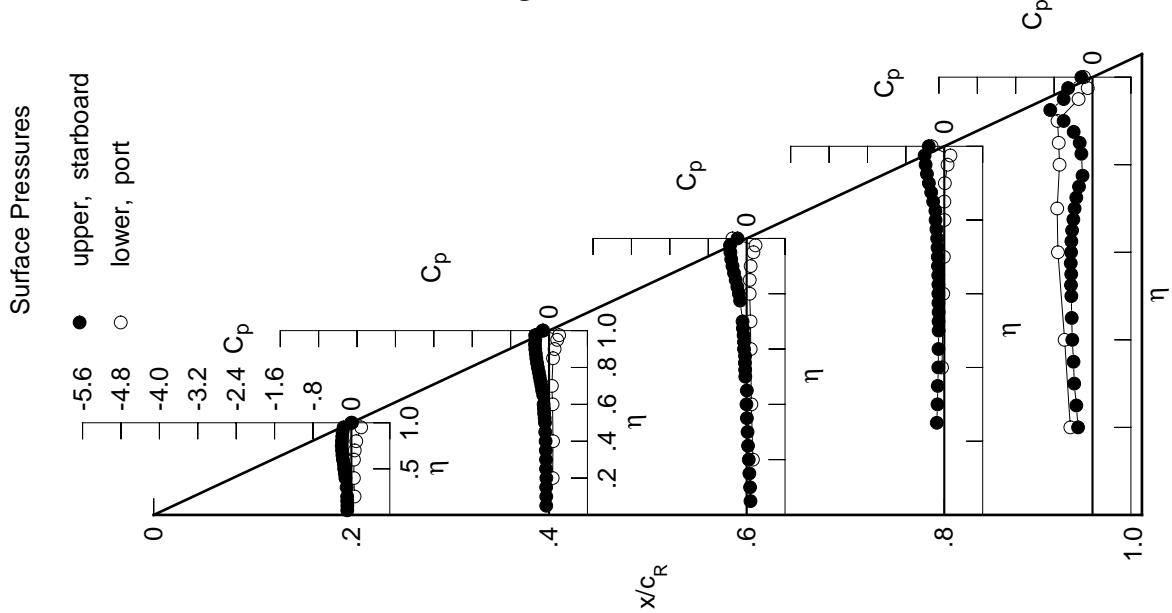

Table H1. Continued.

η	$x/c_R = .2$		$x/c_R = .4$		$x/c_R = .6$		$x/c_R = .8$		$x/c_R = .95$	
	$C_{p,u}$	$C_{p,u}$	$C_{p,u}$	$C_{p,u}$	$C_{p,u}$	$C_{p,u}$	$C_{p,u}$	$C_{p,u}$	$C_{p,u}$	$C_{p,u}$
0.050	-0.1050	-0.0740	0.0670	0.0670	0.0670	0.0670	0.0670	0.0670	0.0670	0.0670
0.100	-0.1032	-0.0741	0.0587	0.0587	0.0587	0.0587	0.0587	0.0587	0.0587	0.0587
0.150	-0.1071	-0.0760	0.0439	0.0439	0.0439	0.0439	0.0439	0.0439	0.0439	0.0439
0.200	-0.1082	-0.0732	0.0312	0.0312	0.0312	0.0312	0.0312	0.0312	0.0312	0.0312
0.250	*****	-0.0799	0.0153	0.0153	0.0153	0.0153	0.0153	0.0153	0.0153	0.0153
0.300	-0.1207	-0.0821	0.0044	0.0044	-0.1494	-0.1494	-0.3709	-0.3709	-0.3709	-0.3709
0.350	*****	-0.0860	-0.0094	-0.1424	-0.3813	-0.3813	-0.3813	-0.3813	-0.3813	-0.3813
0.400	-0.1481	-0.0911	-0.0197	-0.1330	-0.4035	-0.4035	-0.4035	-0.4035	-0.4035	-0.4035
0.450	-0.1613	-0.0994	-0.0128	-0.1303	-0.4153	-0.4153	-0.4153	-0.4153	-0.4153	-0.4153
0.500	-0.1771	-0.1057	-0.0446	-0.1278	-0.4236	-0.4236	-0.4236	-0.4236	-0.4236	-0.4236
0.525	*****	-0.1135	-0.0489	-0.1311	-0.4293	-0.4293	-0.4293	-0.4293	-0.4293	-0.4293
0.550	-0.1866	-0.1246	-0.0557	-0.1289	-0.4257	-0.4257	-0.4257	-0.4257	-0.4257	-0.4257
0.575	*****	-0.1309	-0.0528	-0.1333	-0.4343	-0.4343	-0.4343	-0.4343	-0.4343	-0.4343
0.600	-0.2078	-0.1378	-0.0736	-0.1363	-0.4272	-0.4272	-0.4272	-0.4272	-0.4272	-0.4272
0.625	*****	*****	-0.0764	-0.1371	-0.4205	-0.4205	-0.4205	-0.4205	-0.4205	-0.4205
0.650	-0.2220	-0.1486	-0.0850	-0.1399	-0.4050	-0.4050	-0.4050	-0.4050	-0.4050	-0.4050
0.675	*****	-0.1727	-0.1008	-0.1487	-0.3789	-0.3789	-0.3789	-0.3789	-0.3789	-0.3789
0.700	-0.2341	-0.1923	-0.1096	-0.1528	-0.3518	-0.3518	-0.3518	-0.3518	-0.3518	-0.3518
0.725	*****	-0.2132	*****	-0.1605	-0.3137	-0.3137	-0.3137	-0.3137	-0.3137	-0.3137
0.750	-0.2464	-0.2357	*****	-0.1694	-0.2561	-0.2561	-0.2561	-0.2561	-0.2561	-0.2561
0.775	*****	-0.2573	-0.1688	-0.1884	-0.1799	-0.1799	-0.1799	-0.1799	-0.1799	-0.1799
0.800	-0.2473	-0.2819	-0.1999	-0.2088	*****	*****	*****	*****	*****	*****
0.825	*****	-0.3036	-0.2362	-0.2141	-0.1988	-0.1988	-0.1988	-0.1988	-0.1988	-0.1988
0.850	-0.2481	-0.3252	-0.2796	-0.2681	-0.2413	-0.2413	-0.2413	-0.2413	-0.2413	-0.2413
0.875	*****	-0.3438	-0.3228	-0.3169	-0.3691	-0.3691	-0.3691	-0.3691	-0.3691	-0.3691
0.900	-0.2507	-0.3646	-0.3668	-0.3787	-0.5948	-0.5948	-0.5948	-0.5948	-0.5948	-0.5948
0.925	*****	-0.3810	-0.4068	-0.4341	-0.8698	-0.8698	-0.8698	-0.8698	-0.8698	-0.8698
0.950	-0.2453	-0.3897	-0.4452	-0.4835	-0.6535	-0.6535	-0.6535	-0.6535	-0.6535	-0.6535
0.975	*****	-0.4211	-0.4849	-0.5392	-0.5972	-0.5972	-0.5972	-0.5972	-0.5972	-0.5972
1.000	-0.1234	-0.3701	-0.4093	-0.6246	-0.4434	-0.4434	-0.4434	-0.4434	-0.4434	-0.4434
0.200	$C_{p,l}$	$C_{p,l}$	$C_{p,l}$	$C_{p,l}$	$C_{p,l}$	$C_{p,l}$	$C_{p,l}$	$C_{p,l}$	$C_{p,l}$	$C_{p,l}$
-0.200	0.0873	0.0932	0.1430	*****	-0.4425	-0.4425	-0.4425	-0.4425	-0.4425	-0.4425
-0.400	0.0764	0.1011	0.1123	-0.0337	-0.5615	-0.5615	-0.5615	-0.5615	-0.5615	-0.5615
-0.600	0.0815	0.0951	0.1017	-0.0080	-0.6682	-0.6682	-0.6682	-0.6682	-0.6682	-0.6682
-0.700	0.1007	0.0863	0.0999	0.0069	-0.7004	-0.7004	-0.7004	-0.7004	-0.7004	-0.7004
-0.800	0.1340	*****	0.0886	0.0216	-0.6618	-0.6618	-0.6618	-0.6618	-0.6618	-0.6618
-0.850	*****	0.1172	0.0934	0.0265	-0.6740	-0.6740	-0.6740	-0.6740	-0.6740	-0.6740
-0.900	*****	0.1499	0.1162	0.0430	-0.6894	-0.6894	-0.6894	-0.6894	-0.6894	-0.6894
-0.950	0.2229	0.1961	0.1698	0.1001	-0.2695	-0.2695	-0.2695	-0.2695	-0.2695	-0.2695
-0.975	*****	0.2194	0.1990	0.1483	-0.0762	-0.0762	-0.0762	-0.0762	-0.0762	-0.0762
-1.000	-0.1362	-0.3315	-0.5970	-0.5450	-0.3588	-0.3588	-0.3588	-0.3588	-0.3588	-0.3588

Medium Radius L.E.
 Run No. = 31, Point No. = 626
 $C_N = 0.181$, $C_m = -0.0229$
 $\alpha = 4.9^\circ$, $M_\infty = 0.795$
 $R_{mac} = 117.5 \times 10^6$

Leading Edge Pressures

● starboard
 ○ port

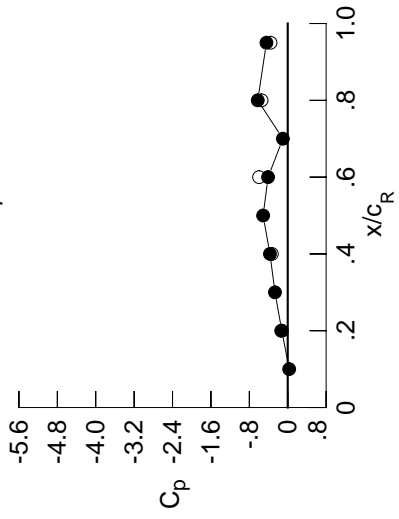

x/c_R	starb'd C_p	port C_p
0.10	0.0304	*****
0.20	-0.1234	-0.1362
0.30	-0.2655	*****
0.40	-0.3701	-0.3315
0.50	-0.5130	*****
0.60	-0.4093	-0.5970
0.70	-0.1009	*****
0.80	-0.6246	-0.5450
0.90	*****	*****
0.95	-0.4434	-0.3588

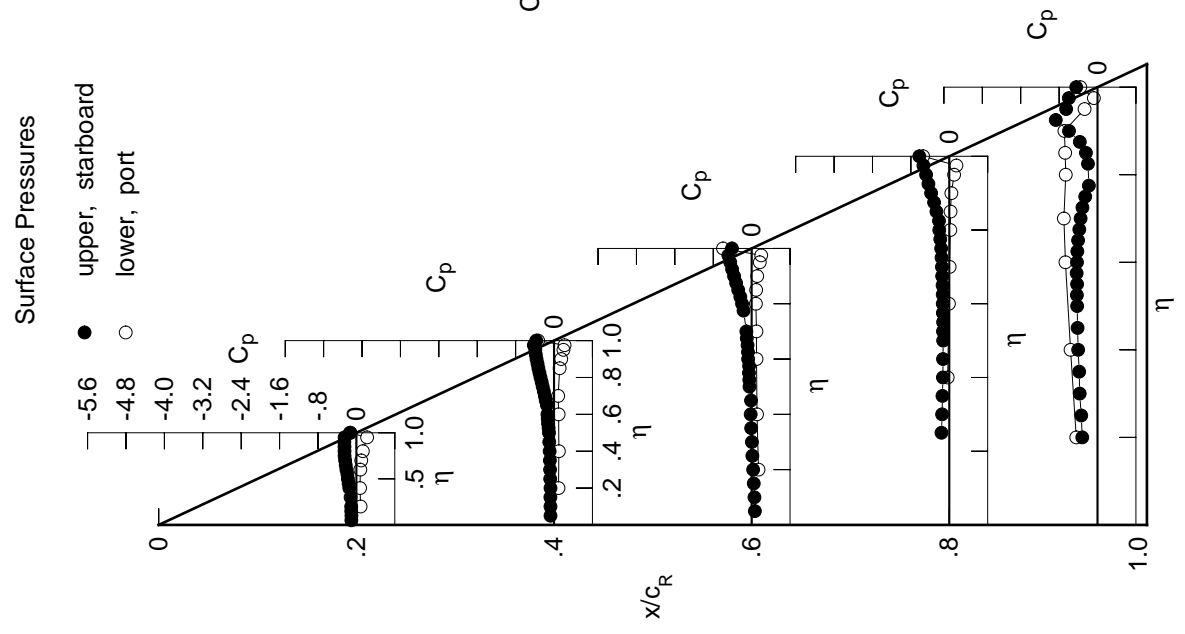
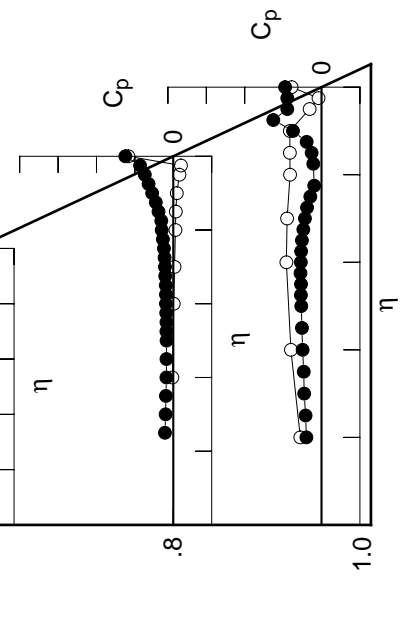
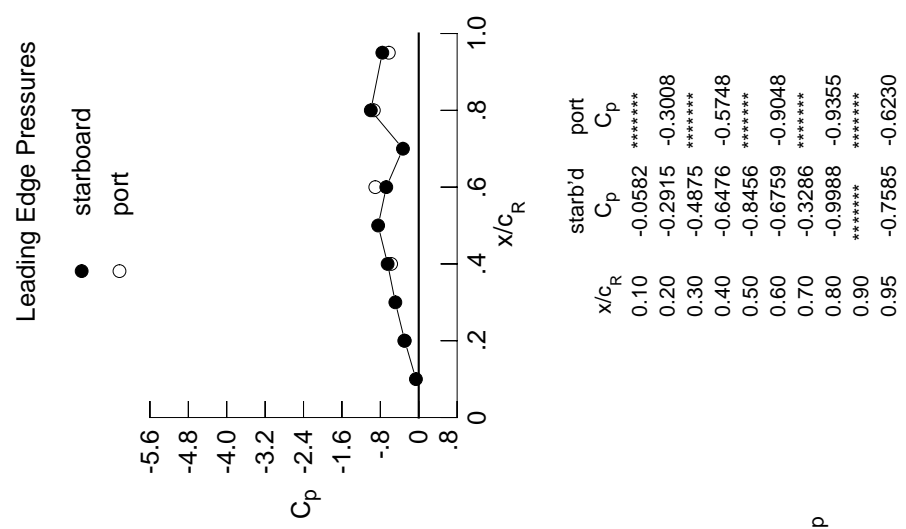

Table H1. Continued.

η	$x/c_R = .2$		$x/c_R = .4$		$x/c_R = .6$		$x/c_R = .8$		$x/c_R = .95$	
	$C_{p,u}$	$C_{p,u}$	$C_{p,u}$	$C_{p,u}$	$C_{p,u}$	$C_{p,u}$	$C_{p,u}$	$C_{p,u}$	$C_{p,u}$	$C_{p,u}$
0.050	-0.1234	-0.0904	0.0584	*****	*****	*****	*****	*****	*****	
0.100	-0.1229	-0.0908	0.0489	*****	*****	*****	*****	*****	*****	
0.150	-0.1261	-0.0940	0.0354	*****	*****	*****	*****	*****	*****	
0.200	-0.1284	-0.0898	0.0213	*****	*****	*****	*****	*****	-0.3149	
0.250	*****	-0.0973	0.0049	-0.1737	-0.3316	*****	*****	*****	*****	
0.300	-0.1410	-0.0994	-0.0060	-0.1595	-0.3609	*****	*****	*****	*****	
0.350	*****	-0.1056	-0.0210	-0.1536	-0.3701	*****	*****	*****	*****	
0.400	-0.1717	-0.1098	-0.0315	-0.1435	-0.3939	*****	*****	*****	*****	
0.450	-0.1857	-0.1204	-0.0258	-0.1417	-0.4079	*****	*****	*****	*****	
0.500	-0.2050	-0.1277	-0.0590	-0.1402	-0.4213	*****	*****	*****	*****	
0.525	*****	-0.1366	-0.0644	-0.1433	-0.4293	*****	*****	*****	*****	
0.550	-0.2170	-0.1498	-0.0719	-0.1426	-0.4275	*****	*****	*****	*****	
0.575	*****	-0.1559	-0.0703	-0.1468	-0.4373	*****	*****	*****	*****	
0.600	-0.2419	-0.1656	-0.0927	-0.1516	-0.4312	*****	*****	*****	*****	
0.625	*****	*****	-0.0953	-0.1525	-0.4246	*****	*****	*****	*****	
0.650	-0.2614	-0.1784	-0.1066	-0.1562	-0.4079	*****	*****	*****	*****	
0.675	*****	-0.2038	-0.1225	-0.1671	-0.3785	*****	*****	*****	*****	
0.700	-0.2774	-0.2265	-0.1346	-0.1725	-0.3454	*****	*****	*****	*****	
0.725	*****	-0.2506	*****	-0.1818	-0.3013	*****	*****	*****	*****	
0.750	-0.2956	-0.2769	*****	-0.1955	-0.2331	*****	*****	*****	*****	
0.775	*****	-0.3040	-0.2031	-0.2171	-0.1518	*****	*****	*****	*****	
0.800	-0.3029	-0.3340	-0.2383	-0.2412	*****	*****	*****	*****	*****	
0.825	*****	-0.3632	-0.2815	-0.2496	-0.1712	*****	*****	*****	*****	
0.850	-0.3123	-0.3914	-0.3325	-0.3077	-0.2054	*****	*****	*****	*****	
0.875	*****	-0.4195	-0.3866	-0.3651	-0.3093	*****	*****	*****	*****	
0.900	-0.3262	-0.4507	-0.4447	-0.4397	-0.5937	*****	*****	*****	*****	
0.925	*****	-0.4813	-0.5035	-0.5150	-1.0042	*****	*****	*****	*****	
0.950	-0.3394	-0.5081	-0.5549	-0.5935	-0.7126	*****	*****	*****	*****	
0.975	*****	-0.5721	-0.6749	-0.6919	-0.7125	*****	*****	*****	*****	
1.000	-0.2915	-0.6476	-0.6759	-0.9988	-0.7585	*****	*****	*****	*****	
-0.200	$C_{p,l}$	$C_{p,l}$	$C_{p,l}$	$C_{p,l}$	$C_{p,l}$	$C_{p,l}$	$C_{p,l}$	$C_{p,l}$	$C_{p,l}$	
-0.400	0.1133	0.1161	0.1621	*****	*****	-0.4417	*****	*****	*****	
-0.600	0.1036	0.1254	0.1325	0.0190	-0.6377	*****	*****	*****	*****	
-0.700	0.1128	0.1217	0.1243	0.0095	-0.7323	*****	*****	*****	*****	
-0.800	0.1337	0.1153	0.1243	0.0261	-0.7166	*****	*****	*****	*****	
-0.850	0.1671	*****	0.1165	0.0447	-0.6549	*****	*****	*****	*****	
-0.900	*****	0.1515	0.1243	0.0526	-0.6595	*****	*****	*****	*****	
-0.950	*****	0.1823	0.1484	0.0736	-0.6594	*****	*****	*****	*****	
-0.975	0.2393	0.2169	0.1938	0.1277	-0.2473	*****	*****	*****	*****	
-1.000	*****	0.2193	0.2045	0.1602	-0.0621	*****	*****	*****	*****	
	-0.3008	-0.5748	-0.9048	-0.9355	-0.6230	*****	*****	*****	*****	

Medium Radius L.E.
 Run No. = 31, Point No. = 627
 $C_N = 0.222$, $C_m = -0.0270$
 $\alpha = 6.0^\circ$, $M_\infty = 0.799$
 $R_{mac} = 120.2 \times 10^6$



x/c_R	starb'd C_p	port C_p
0.10	-0.0582	*****
0.20	-0.2915	-0.3008
0.30	-0.4875	*****
0.40	-0.6476	-0.5748
0.50	-0.8456	*****
0.60	-0.6759	-0.9048
0.70	-0.3286	*****
0.80	-0.9988	-0.9355
0.90	*****	*****
0.95	-0.7585	-0.6230

Table H1. Continued.

η	$x/c_R = .2$		$x/c_R = .4$		$x/c_R = .6$		$x/c_R = .8$		$x/c_R = .95$	
	$C_{p,u}$	$C_{p,u}$	$C_{p,u}$	$C_{p,u}$	$C_{p,u}$	$C_{p,u}$	$C_{p,u}$	$C_{p,u}$	$C_{p,u}$	$C_{p,u}$
0.050	-0.1411	-0.1058	0.0473	*****	*****	*****	*****	*****	*****	*****
0.100	-0.1421	-0.1072	0.0375	*****	*****	*****	*****	*****	*****	*****
0.150	-0.1461	-0.1102	0.0236	*****	*****	*****	*****	*****	*****	*****
0.200	-0.1486	-0.1064	0.0094	*****	*****	*****	*****	*****	*****	*****
0.250	*****	-0.1144	-0.0075	-0.1833	-0.1833	-0.1833	-0.3264	-0.3264	-0.3264	-0.3264
0.300	-0.1621	-0.1171	-0.0188	-0.1696	-0.1696	-0.1696	-0.3505	-0.3505	-0.3505	-0.3505
0.350	*****	-0.1244	-0.0347	-0.1640	-0.1640	-0.1640	-0.3571	-0.3571	-0.3571	-0.3571
0.400	-0.1956	-0.1297	-0.0457	-0.1545	-0.1545	-0.1545	-0.3824	-0.3824	-0.3824	-0.3824
0.450	-0.2117	-0.1417	-0.0419	-0.1530	-0.1530	-0.1530	-0.4069	-0.4069	-0.4069	-0.4069
0.500	-0.2328	-0.1500	-0.0757	-0.1512	-0.1512	-0.1512	-0.4405	-0.4405	-0.4405	-0.4405
0.525	*****	-0.1602	-0.0824	-0.1547	-0.1547	-0.1547	-0.4602	-0.4602	-0.4602	-0.4602
0.550	-0.2478	-0.1741	-0.0897	-0.1537	-0.1537	-0.1537	-0.4657	-0.4657	-0.4657	-0.4657
0.575	*****	-0.1816	-0.0892	-0.1580	-0.1580	-0.1580	-0.4835	-0.4835	-0.4835	-0.4835
0.600	-0.2761	-0.1924	-0.1128	-0.1648	-0.1648	-0.1648	-0.4787	-0.4787	-0.4787	-0.4787
0.625	*****	*****	-0.1175	-0.1688	-0.1688	-0.1688	-0.4713	-0.4713	-0.4713	-0.4713
0.650	-0.3000	-0.2084	-0.1311	-0.1773	-0.1773	-0.1773	-0.4569	-0.4569	-0.4569	-0.4569
0.675	*****	-0.2358	-0.1507	-0.1941	-0.1941	-0.1941	-0.4342	-0.4342	-0.4342	-0.4342
0.700	-0.3209	-0.2610	-0.1662	-0.2094	-0.2094	-0.2094	-0.4060	-0.4060	-0.4060	-0.4060
0.725	*****	-0.2883	*****	-0.2250	-0.2250	-0.2250	-0.3612	-0.3612	-0.3612	-0.3612
0.750	-0.3450	-0.3186	*****	-0.2441	-0.2441	-0.2441	-0.3040	-0.3040	-0.3040	-0.3040
0.775	*****	-0.3513	-0.2440	-0.2663	-0.2663	-0.2663	-0.2165	-0.2165	-0.2165	-0.2165
0.800	-0.3595	-0.3863	-0.2794	-0.2876	-0.2876	-0.2876	*****	*****	*****	*****
0.825	*****	-0.4228	-0.3236	-0.3015	-0.3015	-0.3015	-0.1758	-0.1758	-0.1758	-0.1758
0.850	-0.3783	-0.4584	-0.3791	-0.3384	-0.3384	-0.3384	-0.1891	-0.1891	-0.1891	-0.1891
0.875	*****	-0.4969	-0.4409	-0.3887	-0.3887	-0.3887	-0.2367	-0.2367	-0.2367	-0.2367
0.900	-0.4051	-0.5384	-0.5119	-0.4849	-0.4849	-0.4849	-0.3626	-0.3626	-0.3626	-0.3626
0.925	*****	-0.5851	-0.5981	-0.5609	-0.5609	-0.5609	-0.6716	-0.6716	-0.6716	-0.6716
0.950	-0.4393	-0.6315	-0.6770	-0.6663	-0.6663	-0.6663	-0.7487	-0.7487	-0.7487	-0.7487
0.975	*****	-0.7457	-0.7739	-0.7871	-0.7871	-0.7871	-0.7966	-0.7966	-0.7966	-0.7966
1.000	-0.4810	-0.9569	-0.8802	-1.2790	-1.2790	-1.2790	-1.0184	-1.0184	-1.0184	-1.0184
-0.200	$C_{p,l}$	$C_{p,l}$	$C_{p,l}$	$C_{p,l}$	$C_{p,l}$	$C_{p,l}$	$C_{p,l}$	$C_{p,l}$	$C_{p,l}$	$C_{p,l}$
-0.400	0.1374	0.1362	0.1779	*****	*****	*****	-0.4475	-0.4475	-0.4475	-0.4475
-0.600	0.1294	0.1467	0.1493	-0.0048	-0.0048	-0.0048	-0.6529	-0.6529	-0.6529	-0.6529
-0.700	0.1413	0.1450	0.1427	0.0252	0.0252	0.0252	-0.7127	-0.7127	-0.7127	-0.7127
-0.800	0.1630	0.1415	0.1446	0.0426	0.0426	0.0426	-0.6964	-0.6964	-0.6964	-0.6964
-0.850	0.1957	*****	0.1406	0.0636	0.0636	0.0636	-0.6338	-0.6338	-0.6338	-0.6338
-0.900	*****	0.1803	0.1505	0.0749	0.0749	0.0749	-0.6338	-0.6338	-0.6338	-0.6338
-0.950	*****	0.2080	0.1739	0.0986	0.0986	0.0986	-0.6259	-0.6259	-0.6259	-0.6259
-0.975	0.2459	0.2288	0.2084	0.1468	0.1468	0.1468	-0.2321	-0.2321	-0.2321	-0.2321
-1.000	*****	0.2081	0.1987	0.1603	0.1603	0.1603	-0.0587	-0.0587	-0.0587	-0.0587
-1.000	-0.4937	-0.8351	-1.1290	-1.1660	-1.1660	-1.1660	-0.9186	-0.9186	-0.9186	-0.9186

Medium Radius L.E.

Run No. = 31, Point No. = 628

$C_N = 0.269$, $C_m = -0.0355$

$\alpha = 7.1^\circ$, $M_\infty = 0.800$

$R_{mac} = 120.1 \times 10^6$

Leading Edge Pressures

● starboard
○ port

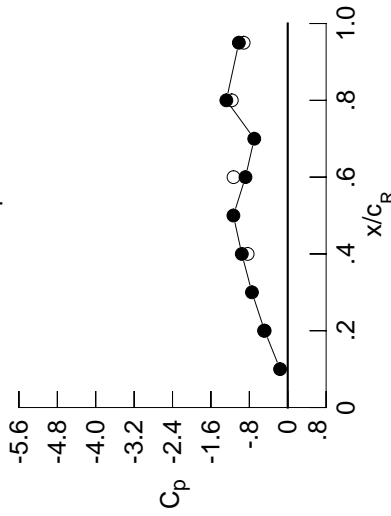

x/c_R	starb'd C_p	port C_p
0.10	-0.1593	*****
0.20	-0.4810	-0.4937
0.30	-0.7455	*****
0.40	-0.9569	-0.8351
0.50	-1.1321	*****
0.60	-0.8802	-1.1290
0.70	-0.6974	*****
0.80	-1.2790	-1.1660
0.90	*****	*****
0.95	-1.0184	-0.9186

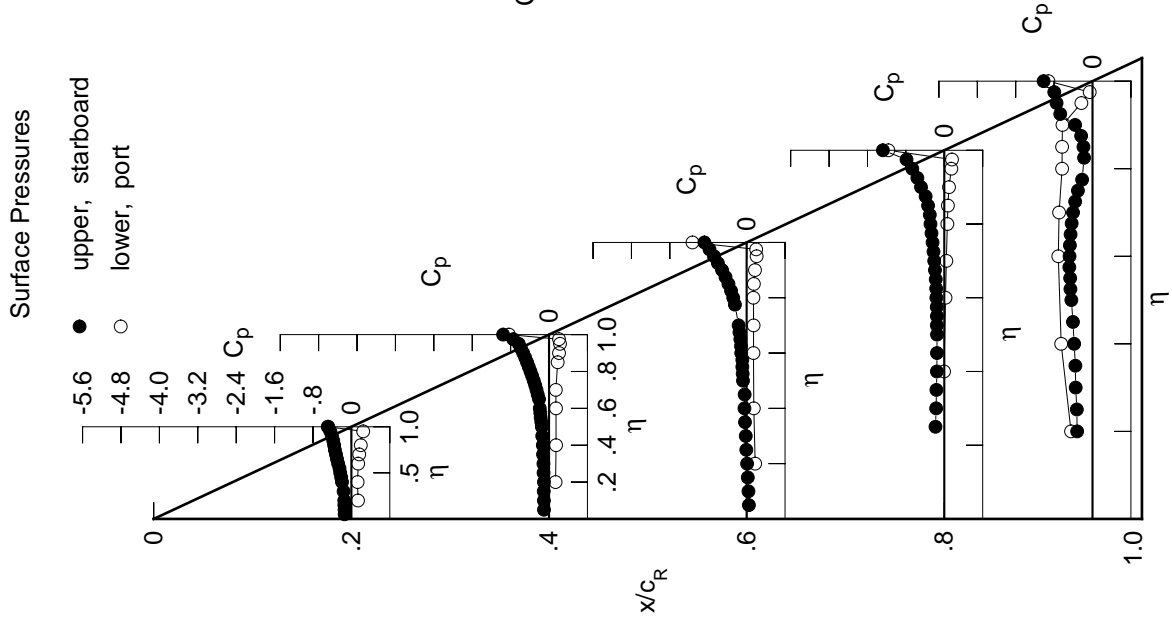

Table H1. Continued.

η	$x/c_R = .2$		$x/c_R = .4$		$x/c_R = .6$		$x/c_R = .8$		$x/c_R = .95$	
	$C_{p,u}$	$C_{p,u}$	$C_{p,u}$	$C_{p,u}$	$C_{p,u}$	$C_{p,u}$	$C_{p,u}$	$C_{p,u}$	$C_{p,u}$	$C_{p,u}$
0.050	-0.1562	-0.1222	0.0336	*****	*****	*****	*****	*****	*****	
0.100	-0.1591	-0.1241	0.0228	*****	*****	*****	*****	*****	*****	
0.150	-0.1643	-0.1288	0.0085	*****	*****	*****	*****	*****	*****	
0.200	-0.1669	-0.1239	-0.0062	*****	*****	*****	*****	*****	-0.3198	
0.250	*****	-0.1326	-0.0234	-0.1999	-0.3130	*****	*****	*****	*****	
0.300	-0.1824	-0.1358	-0.0362	-0.1849	-0.3331	*****	*****	*****	*****	
0.350	*****	-0.1443	-0.0511	-0.1806	-0.3392	*****	*****	*****	*****	
0.400	-0.2184	-0.1502	-0.0635	-0.1692	-0.3891	*****	*****	*****	*****	
0.450	-0.2358	-0.1641	-0.0609	-0.1677	-0.4254	*****	*****	*****	*****	
0.500	-0.2595	-0.1722	-0.0949	-0.1695	-0.4450	*****	*****	*****	*****	
0.525	*****	-0.1853	-0.1048	-0.1753	-0.4487	*****	*****	*****	*****	
0.550	-0.2781	-0.2018	-0.1170	-0.1801	-0.4358	*****	*****	*****	*****	
0.575	*****	-0.2128	-0.1220	-0.1953	-0.4223	*****	*****	*****	*****	
0.600	-0.3096	-0.2262	-0.1532	-0.2140	-0.4054	*****	*****	*****	*****	
0.625	*****	*****	-0.1606	-0.2195	-0.4042	*****	*****	*****	*****	
0.650	-0.3390	-0.2454	-0.1798	-0.2173	-0.4075	*****	*****	*****	*****	
0.675	*****	-0.2720	-0.2022	-0.2199	-0.4065	*****	*****	*****	*****	
0.700	-0.3651	-0.2995	-0.2176	-0.2209	-0.4190	*****	*****	*****	*****	
0.725	*****	-0.3281	*****	-0.2390	-0.4158	*****	*****	*****	*****	
0.750	-0.3961	-0.3611	*****	-0.2882	-0.3809	*****	*****	*****	*****	
0.775	*****	-0.3976	-0.2848	-0.3342	-0.3765	*****	*****	*****	*****	
0.800	-0.4190	-0.4372	-0.3140	-0.3593	*****	*****	*****	*****	*****	
0.825	*****	-0.4806	-0.3539	-0.4068	-0.4790	*****	*****	*****	*****	
0.850	-0.4484	-0.5230	-0.4007	-0.4830	-0.5735	*****	*****	*****	*****	
0.875	*****	-0.5710	-0.4722	-0.4351	-0.7368	*****	*****	*****	*****	
0.900	-0.4898	-0.6227	-0.6093	-0.4163	-0.8167	*****	*****	*****	*****	
0.925	*****	-0.6826	-0.8267	-0.6086	-0.8244	*****	*****	*****	*****	
0.950	-0.5453	-0.7409	-1.0183	-0.9809	-0.7111	*****	*****	*****	*****	
0.975	*****	-0.9428	-1.0978	-1.0201	-0.8460	*****	*****	*****	*****	
1.000	-0.7121	-1.2144	-0.9851	-1.3932	-1.2019	*****	*****	*****	*****	
-0.200	$C_{p,l}$	0.1641	0.1602	0.1972	*****	*****	*****	*****	-0.4518	
-0.400	$C_{p,l}$	0.1575	0.1714	0.1695	0.0119	-0.6225	*****	*****	*****	
-0.600	$C_{p,l}$	0.1715	0.1711	0.1651	0.0443	-0.6665	*****	*****	*****	
-0.700	$C_{p,l}$	0.1940	0.1699	0.1686	0.0626	-0.6576	*****	*****	*****	
-0.800	$C_{p,l}$	0.2250	*****	0.1668	0.0857	-0.5930	*****	*****	*****	
-0.850	$C_{p,l}$	*****	0.2095	0.1777	0.0988	-0.5924	*****	*****	*****	
-0.900	$C_{p,l}$	*****	0.2330	0.1999	0.1233	-0.5830	*****	*****	*****	
-0.950	$C_{p,l}$	0.2487	0.2376	0.2219	0.1640	-0.2130	*****	*****	*****	
-0.975	$C_{p,l}$	*****	0.1921	0.1928	0.1651	-0.0505	*****	*****	*****	
-1.000	$C_{p,l}$	-0.7292	-1.0839	-1.2879	-1.2421	-0.9880	*****	*****	*****	

Medium Radius L.E.
 Run No. = 31, Point No. = 629
 $C_N = 0.329$, $C_m = -0.0493$
 $\alpha = 8.2^\circ$, $M_\infty = 0.797$
 $R_{mac} = 120.1 \times 10^6$

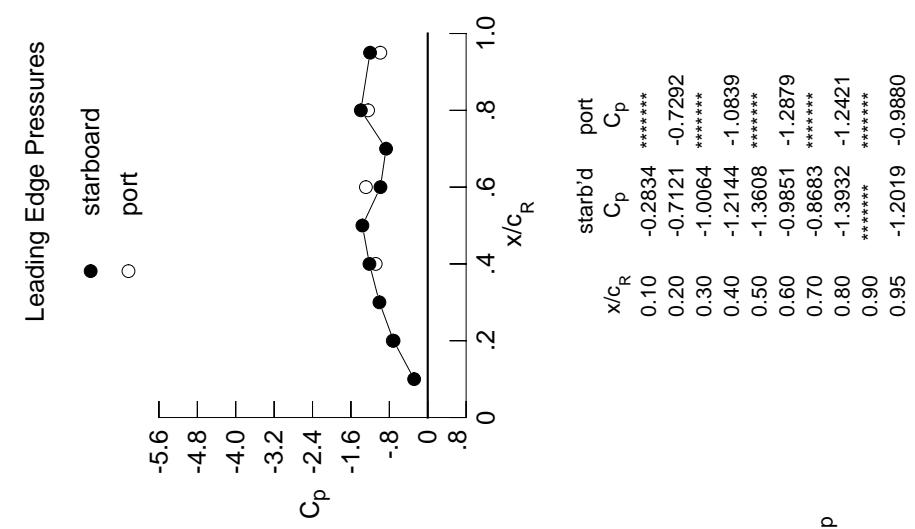
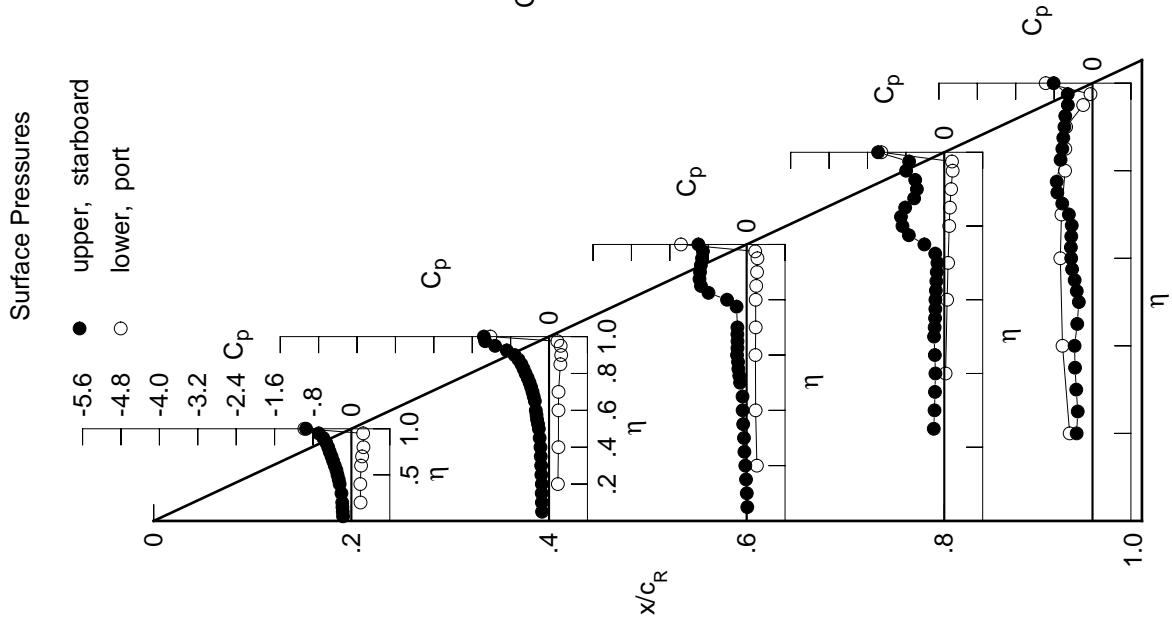
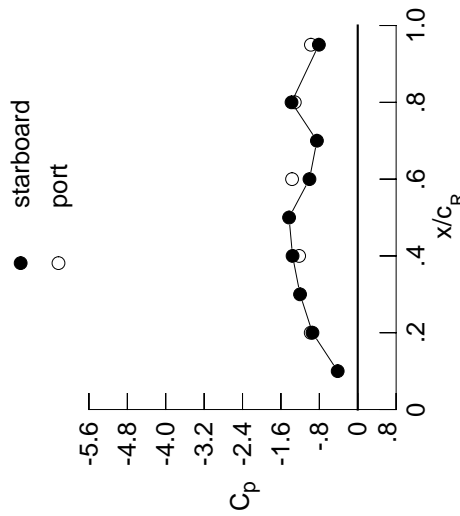

Table H1. Continued.

η	$x/c_R = .2$		$x/c_R = .4$		$x/c_R = .6$		$x/c_R = .8$		$x/c_R = .95$	
	$C_{p,u}$	$C_{p,u}$	$C_{p,u}$	$C_{p,u}$	$C_{p,u}$	$C_{p,u}$	$C_{p,u}$	$C_{p,u}$	$C_{p,u}$	$C_{p,u}$
0.050	-0.1736	-0.1459	0.0135	*****	*****	*****	*****	*****	*****	*****
0.100	-0.1804	-0.1492	0.0031	*****	*****	*****	*****	*****	*****	*****
0.150	-0.1861	-0.1531	-0.0131	*****	*****	*****	*****	*****	*****	*****
0.200	-0.1903	-0.1505	-0.0277	*****	*****	*****	*****	*****	*****	*****
0.250	*****	-0.1598	-0.0465	-0.2192	-0.3077	*****	*****	*****	*****	*****
0.300	-0.2069	-0.1644	-0.0564	-0.2030	-0.3381	*****	*****	*****	*****	*****
0.350	*****	-0.1724	-0.0717	-0.1944	-0.3644	*****	*****	*****	*****	*****
0.400	-0.2445	-0.1783	-0.0839	-0.1852	-0.3735	*****	*****	*****	*****	*****
0.450	-0.2641	-0.1951	-0.0852	-0.1968	-0.3183	*****	*****	*****	*****	*****
0.500	-0.2897	-0.2125	-0.1364	-0.2134	-0.2845	*****	*****	*****	*****	*****
0.525	*****	-0.2290	-0.1539	-0.2011	-0.3283	*****	*****	*****	*****	*****
0.550	-0.3114	-0.2498	-0.1728	-0.1917	-0.3722	*****	*****	*****	*****	*****
0.575	*****	-0.2609	-0.1788	-0.1866	-0.4255	*****	*****	*****	*****	*****
0.600	-0.3467	-0.2761	-0.1997	-0.1849	-0.4442	*****	*****	*****	*****	*****
0.625	*****	*****	-0.1914	-0.1757	-0.4506	*****	*****	*****	*****	*****
0.650	-0.3804	-0.2954	-0.1900	-0.1656	-0.4424	*****	*****	*****	*****	*****
0.675	*****	-0.3198	-0.1935	-0.1570	-0.4325	*****	*****	*****	*****	*****
0.700	-0.4135	-0.3442	-0.1924	-0.1429	-0.4929	*****	*****	*****	*****	*****
0.725	*****	-0.3726	*****	-0.1886	-0.6301	*****	*****	*****	*****	*****
0.750	-0.4516	-0.4055	*****	-0.4154	-0.7325	*****	*****	*****	*****	*****
0.775	*****	-0.4446	-0.2097	-0.7384	-0.7462	*****	*****	*****	*****	*****
0.800	-0.4840	-0.4885	-0.4084	-0.8711	*****	*****	*****	*****	*****	*****
0.825	*****	-0.5304	-0.7955	-0.9026	-0.6659	*****	*****	*****	*****	*****
0.850	-0.5265	-0.5751	-0.9509	-0.8146	-0.6287	*****	*****	*****	*****	*****
0.875	*****	-0.6363	-0.9826	-0.6283	-0.6086	*****	*****	*****	*****	*****
0.900	-0.5854	-0.7184	-0.9709	-0.5703	-0.5850	*****	*****	*****	*****	*****
0.925	*****	-0.8800	-0.9534	-0.6067	-0.5683	*****	*****	*****	*****	*****
0.950	-0.6802	-1.1240	-0.9292	-0.7953	-0.5137	*****	*****	*****	*****	*****
0.975	*****	-1.3311	-0.9100	-0.7330	-0.5156	*****	*****	*****	*****	*****
1.000	-0.9430	-1.3579	-1.0052	-1.3793	-0.8096	*****	*****	*****	*****	*****
-0.200	$C_{p,l}$	0.1908	0.1841	0.2138	*****	*****	*****	*****	*****	*****
-0.400		0.1854	0.1954	0.1875	0.0273	-0.6247	*****	*****	*****	*****
-0.600		0.2014	0.1967	0.1834	0.0595	-0.6702	*****	*****	*****	*****
-0.700		0.2234	0.1974	0.1885	0.0791	-0.6469	*****	*****	*****	*****
-0.800		0.2510	*****	0.1880	0.1030	-0.5722	*****	*****	*****	*****
-0.850		*****	0.2360	0.1989	0.1175	-0.5668	*****	*****	*****	*****
-0.900		*****	0.2539	0.2169	0.1420	-0.5492	*****	*****	*****	*****
-0.950		0.2445	0.2426	0.2247	0.1740	-0.1942	*****	*****	*****	*****
-0.975		*****	0.1738	0.1772	0.1598	-0.0426	*****	*****	*****	*****
-1.000		-0.9793	-1.2212	-1.3679	-1.3114	-0.9754	*****	*****	*****	*****

Medium Radius L.E.
 Run No. = 31, Point No. = 630
 $C_N = 0.388$, $C_m = -0.0588$
 $\alpha = 9.3^\circ$, $M_\infty = 0.800$
 $R_{mac} = 120.3 \times 10^6$

Leading Edge Pressures



x/c_R	starb'd C_p	port C_p
0.10	-0.4180	*****
0.20	-0.9430	-0.9793
0.30	-1.2015	*****
0.40	-1.3579	-1.2212
0.50	-1.4308	*****
0.60	-1.0052	-1.3679
0.70	-0.8504	*****
0.80	-1.3793	-1.3114
0.90	*****	*****
0.95	-0.8096	-0.9754

Table H1. Continued.

η	x/c_R .2	x/c_R .4	x/c_R .6	x/c_R .8	x/c_R .95
	$C_{p,u}$	$C_{p,u}$	$C_{p,u}$	$C_{p,u}$	$C_{p,u}$
0.050	-0.1899	-0.1733	-0.0097	*****	*****
0.100	-0.1989	-0.1778	-0.0215	*****	*****
0.150	-0.2071	-0.1826	-0.0379	*****	*****
0.200	-0.2127	-0.1804	-0.0537	*****	-0.2999
0.250	*****	-0.1904	-0.0680	-0.2317	-0.2806
0.300	-0.2306	-0.1930	-0.0774	-0.2128	-0.3255
0.350	*****	-0.2006	-0.0984	-0.2127	-0.3149
0.400	-0.2700	-0.2142	-0.1278	-0.2221	-0.2599
0.450	-0.2908	-0.2445	-0.1442	-0.2011	-0.3100
0.500	-0.3192	-0.2676	-0.1626	-0.1889	-0.4092
0.525	*****	-0.2824	-0.1611	-0.1881	-0.4500
0.550	-0.3450	-0.2976	-0.1586	-0.1810	-0.4676
0.575	*****	-0.3043	-0.1496	-0.1771	-0.4937
0.600	-0.3844	-0.3133	-0.1706	-0.1720	-0.4838
0.625	*****	*****	-0.1651	-0.1585	-0.4757
0.650	-0.4238	-0.3253	-0.1618	-0.1579	-0.4830
0.675	*****	-0.3467	-0.1599	-0.2056	-0.5274
0.700	-0.4626	-0.3672	-0.1490	-0.3558	-0.6696
0.725	*****	-0.3859	*****	-0.6415	-0.8485
0.750	-0.5087	-0.4017	*****	-0.8937	-0.9580
0.775	*****	-0.4152	-0.9771	-1.0451	-0.9400
0.800	-0.5527	-0.5025	-1.1014	-1.0296	*****
0.825	*****	-0.7589	-1.1114	-1.0200	-0.6247
0.850	-0.6035	-0.9790	-1.0594	-0.8479	-0.5579
0.875	*****	-1.0879	-1.0040	-0.6965	-0.5379
0.900	-0.6695	-1.1657	-0.9265	-0.6705	-0.5216
0.925	*****	-1.1893	-0.8695	-0.6332	-0.5295
0.950	-0.7829	-1.2018	-0.8302	-0.6904	-0.4856
0.975	*****	-1.1747	-0.8108	-0.6415	-0.4378
1.000	-1.1272	-1.4177	-0.9926	-1.3387	-0.6352
	$C_{p,l}$	$C_{p,l}$	$C_{p,l}$	$C_{p,l}$	$C_{p,l}$
-0.200	0.2216	0.2110	0.2341	*****	-0.5210
-0.400	0.2184	0.2236	0.2088	0.0428	-0.6974
-0.600	0.2357	0.2263	0.2066	0.0758	-0.6639
-0.700	0.2566	0.2286	0.2127	0.0958	-0.6237
-0.800	0.2810	*****	0.2137	0.1213	-0.5539
-0.850	*****	0.2650	0.2250	0.1358	-0.5500
-0.900	*****	0.2771	0.2415	0.1594	-0.5291
-0.950	0.2413	0.2502	0.2403	0.1843	-0.1784
-0.975	*****	0.1620	0.1816	0.1605	-0.0265
-1.000	-1.1921	-1.2928	-1.3496	-1.2702	-0.5890

Medium Radius L.E.
 Run No. = 31, Point No. = 631
 $C_N = 0.450$, $C_m = -0.0673$
 $\alpha = 10.4^\circ$, $M_\infty = 0.798$
 $R_{mac} = 119.9 \times 10^6$

Leading Edge Pressures

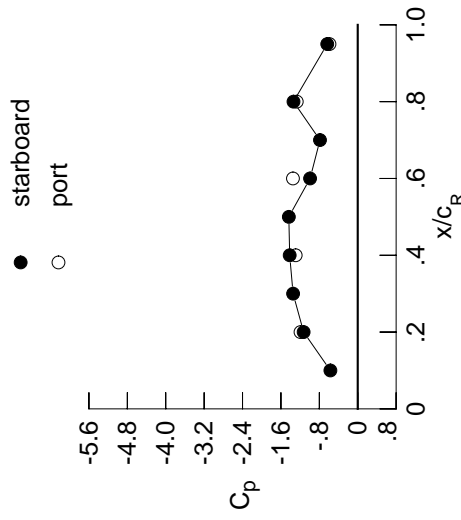

x/c_R	starb'd C_p	port C_p
0.10	-0.5699	*****
0.20	-1.1272	-1.1921
0.30	-1.3467	*****
0.40	-1.4177	-1.2928
0.50	-1.4356	*****
0.60	-0.9926	-1.3496
0.70	-0.7864	*****
0.80	-1.3387	-1.2702
0.90	*****	*****
0.95	-0.6352	-0.5890

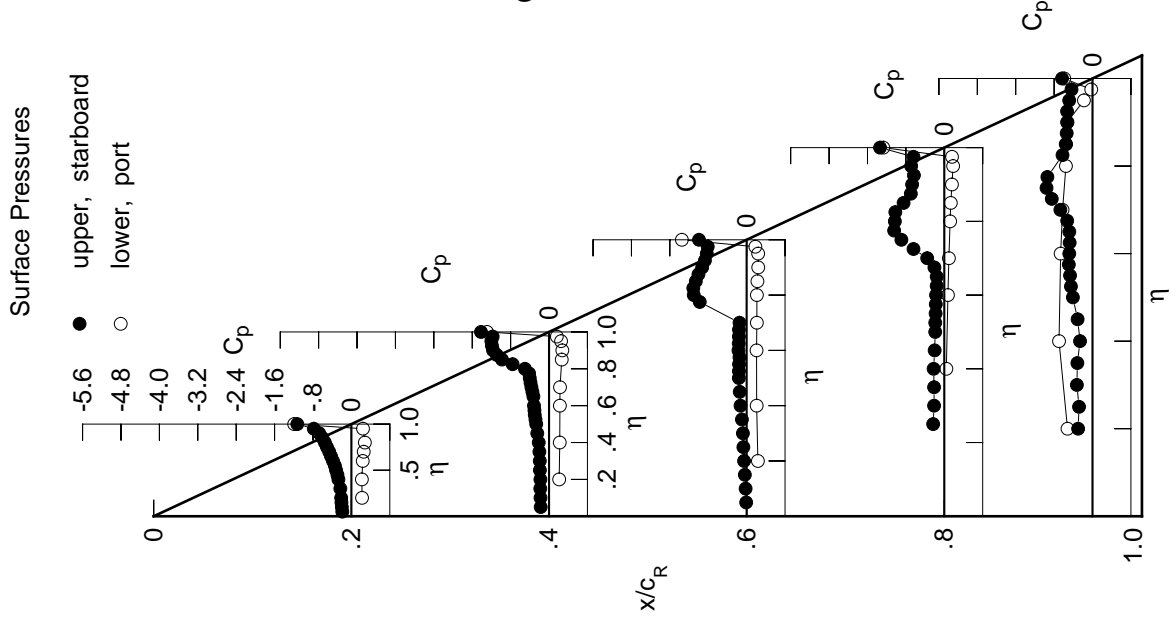
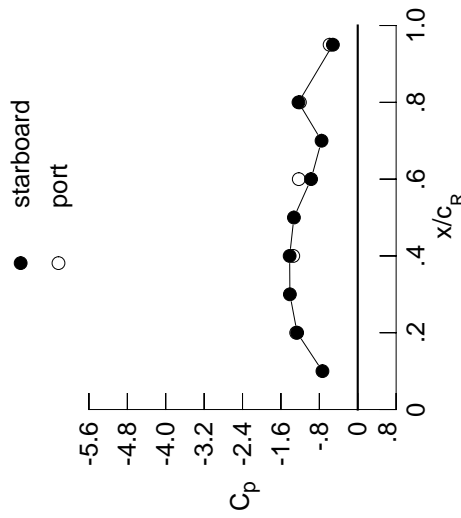

Table H1. Continued.

η	$x/c_R = .2$		$x/c_R = .4$		$x/c_R = .6$		$x/c_R = .8$		$x/c_R = .95$	
	$C_{p,u}$	$C_{p,u}$	$C_{p,u}$	$C_{p,u}$	$C_{p,u}$	$C_{p,u}$	$C_{p,u}$	$C_{p,u}$	$C_{p,u}$	$C_{p,u}$
0.050	-0.2113	-0.2050	-0.0326	*****	*****	*****	*****	*****	*****	*****
0.100	-0.2193	-0.2076	-0.0434	*****	*****	*****	*****	*****	*****	*****
0.150	-0.2327	-0.2135	-0.0625	*****	*****	*****	*****	*****	*****	*****
0.200	-0.2392	-0.2130	-0.0718	*****	*****	*****	*****	*****	*****	*****
0.250	*****	-0.2168	-0.0901	-0.2428	-0.3264	*****	*****	*****	*****	*****
0.300	-0.2603	-0.2216	-0.1059	-0.2315	-0.3471	*****	*****	*****	*****	*****
0.350	*****	-0.2412	-0.1461	-0.2400	-0.2993	*****	*****	*****	*****	*****
0.400	-0.3022	-0.2656	-0.1620	-0.2168	-0.3075	*****	*****	*****	*****	*****
0.450	-0.3266	-0.2900	-0.1425	-0.2058	-0.3885	*****	*****	*****	*****	*****
0.500	-0.3569	-0.3158	-0.1648	-0.1918	-0.4596	*****	*****	*****	*****	*****
0.525	*****	-0.3201	-0.1647	-0.1896	-0.4815	*****	*****	*****	*****	*****
0.550	-0.3849	-0.3210	-0.1630	-0.1806	-0.4812	*****	*****	*****	*****	*****
0.575	*****	-0.3161	-0.1461	-0.1797	-0.4941	*****	*****	*****	*****	*****
0.600	-0.4248	-0.3160	-0.1641	-0.1884	-0.4885	*****	*****	*****	*****	*****
0.625	*****	*****	-0.1572	-0.2175	-0.5165	*****	*****	*****	*****	*****
0.650	-0.4668	-0.3080	-0.1991	-0.3144	-0.6028	*****	*****	*****	*****	*****
0.675	*****	-0.3340	-0.3296	-0.5162	-0.7225	*****	*****	*****	*****	*****
0.700	-0.5129	-0.3433	-0.5555	-0.7700	-0.8658	*****	*****	*****	*****	*****
0.725	*****	-0.3452	*****	-0.9765	-0.9678	*****	*****	*****	*****	*****
0.750	-0.5659	-0.4610	*****	-1.0701	-0.9638	*****	*****	*****	*****	*****
0.775	*****	-0.8581	-1.0887	-1.1105	-0.8462	*****	*****	*****	*****	*****
0.800	-0.6101	-1.1333	-1.0897	-1.0283	*****	*****	*****	*****	*****	*****
0.825	*****	-1.2135	-1.0635	-0.9401	-0.5620	*****	*****	*****	*****	*****
0.850	-0.6616	-1.2188	-1.0099	-0.7665	-0.5187	*****	*****	*****	*****	*****
0.875	*****	-1.2139	-0.9640	-0.6943	-0.4966	*****	*****	*****	*****	*****
0.900	-0.7613	-1.2071	-0.9116	-0.6712	-0.4799	*****	*****	*****	*****	*****
0.925	*****	-1.1758	-0.8715	-0.6305	-0.4725	*****	*****	*****	*****	*****
0.950	-1.1973	-1.1544	-0.8403	-0.7299	-0.4165	*****	*****	*****	*****	*****
0.975	*****	-1.1233	-0.8139	-0.6553	-0.3571	*****	*****	*****	*****	*****
1.000	-1.2627	-1.4183	-0.9721	-1.2341	-0.5178	*****	*****	*****	*****	*****
-0.200	$C_{p,l}$	$C_{p,l}$	$C_{p,l}$	$C_{p,l}$	$C_{p,l}$	$C_{p,l}$	$C_{p,l}$	$C_{p,l}$	$C_{p,l}$	$C_{p,l}$
-0.400	0.2500	0.2355	0.2504	*****	*****	-0.5239	*****	*****	*****	*****
-0.600	0.2477	0.2483	0.2263	0.0568	-0.6916	*****	*****	*****	*****	*****
-0.700	0.2656	0.2510	0.2250	0.0886	-0.6741	*****	*****	*****	*****	*****
-0.800	0.2845	0.2537	0.2319	0.1096	-0.6373	*****	*****	*****	*****	*****
-0.850	0.3049	*****	0.2329	0.1345	-0.5606	*****	*****	*****	*****	*****
-0.900	*****	0.2869	0.2438	0.1494	-0.5499	*****	*****	*****	*****	*****
-0.950	0.2326	0.2927	0.2559	0.1715	-0.5208	*****	*****	*****	*****	*****
-0.975	0.2332	0.2501	0.2428	0.1877	-0.1754	*****	*****	*****	*****	*****
-1.000	0.2336	0.1431	0.1706	0.1510	-0.0325	*****	*****	*****	*****	*****
-1.000	-1.2827	-1.3433	-1.2282	-1.2045	-0.5860	*****	*****	*****	*****	*****

Medium Radius L.E.
 Run No. = 31, Point No. = 632
 $C_N = 0.508$, $C_m = -0.0745$
 $\alpha = 11.4^\circ$, $M_\infty = 0.797$
 $R_{mac} = 119.7 \times 10^6$

Leading Edge Pressures



x/c_R	starb'd C_p	port C_p
0.10	-0.7353	*****
0.20	-1.2627	-1.2827
0.30	-1.4134	*****
0.40	-1.4183	-1.3433
0.50	-1.3299	*****
0.60	-0.9721	-1.2282
0.70	-0.7539	*****
0.80	-1.2341	-1.2045
0.90	*****	*****
0.95	-0.5178	-0.5860

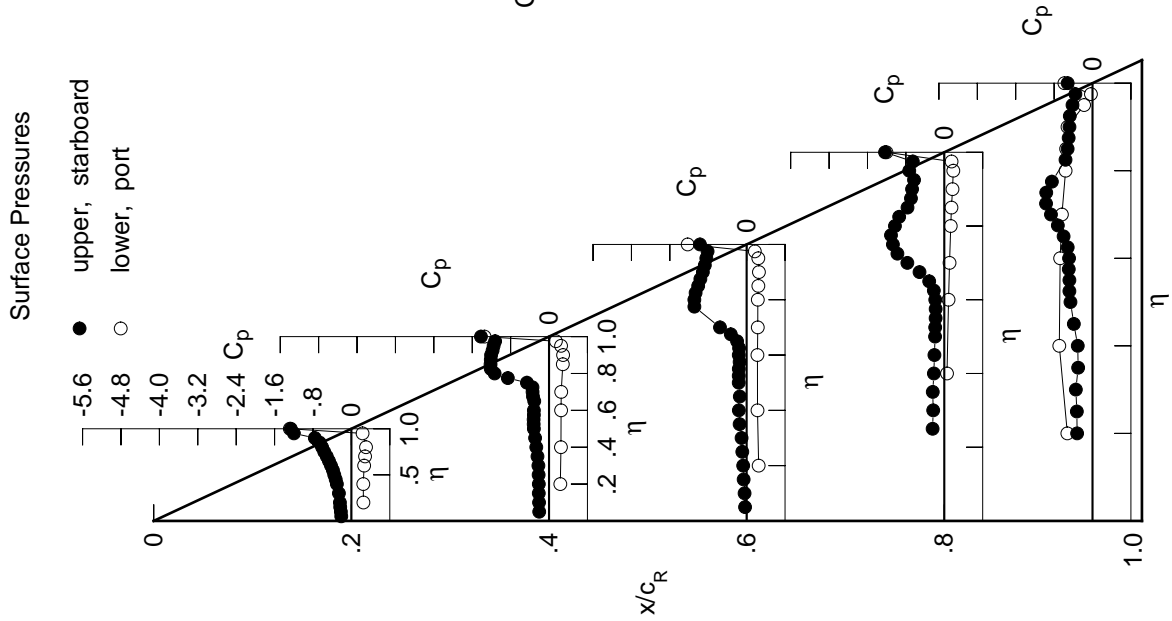

Table H1. Continued.

η	$x/c_R = .2$		$x/c_R = .4$		$x/c_R = .6$		$x/c_R = .8$		$x/c_R = .95$	
	$C_{p,u}$	$C_{p,u}$	$C_{p,u}$	$C_{p,u}$	$C_{p,u}$	$C_{p,u}$	$C_{p,u}$	$C_{p,u}$	$C_{p,u}$	$C_{p,u}$
0.050	-0.2312	-0.2356	-0.0449	*****	*****	*****	*****	*****	*****	*****
0.100	-0.2349	-0.2367	-0.0553	*****	*****	*****	*****	*****	*****	*****
0.150	-0.2529	-0.2430	-0.0738	*****	*****	*****	*****	*****	*****	*****
0.200	-0.2641	-0.2396	-0.0835	*****	*****	*****	*****	*****	*****	-0.3857
0.250	*****	-0.2441	-0.1043	-0.2275	-0.3981	*****	*****	*****	*****	-0.3981
0.300	-0.2935	-0.2579	-0.1321	-0.2216	-0.4198	*****	*****	*****	*****	-0.4198
0.350	*****	-0.2896	-0.1681	-0.2196	-0.3928	*****	*****	*****	*****	-0.3928
0.400	-0.3424	-0.3041	-0.1699	-0.1931	-0.4496	*****	*****	*****	*****	-0.4496
0.450	-0.3634	-0.3407	-0.1484	-0.1801	-0.5222	*****	*****	*****	*****	-0.5222
0.500	-0.3903	-0.3477	-0.1723	-0.1653	-0.5373	*****	*****	*****	*****	-0.5373
0.525	*****	-0.3461	-0.1728	-0.1639	-0.5356	*****	*****	*****	*****	-0.5356
0.550	-0.4169	-0.3528	-0.1713	-0.1626	-0.5059	*****	*****	*****	*****	-0.5059
0.575	*****	-0.3486	-0.1553	-0.1742	-0.5145	*****	*****	*****	*****	-0.5145
0.600	-0.4588	-0.3420	-0.1822	-0.2079	-0.5012	*****	*****	*****	*****	-0.5012
0.625	*****	*****	-0.1902	-0.2776	-0.5269	*****	*****	*****	*****	-0.5269
0.650	-0.5045	-0.3260	-0.2743	-0.4173	-0.5711	*****	*****	*****	*****	-0.5711
0.675	*****	-0.3304	-0.4798	-0.6397	-0.5846	*****	*****	*****	*****	-0.5846
0.700	-0.5501	-0.3142	-0.7778	-0.8859	-0.6029	*****	*****	*****	*****	-0.6029
0.725	*****	-0.3846	*****	-1.1061	-0.6282	*****	*****	*****	*****	-0.6282
0.750	-0.5993	-0.9314	*****	-1.2280	-0.5983	*****	*****	*****	*****	-0.5983
0.775	*****	-1.3743	-1.3527	-0.9895	-0.5437	*****	*****	*****	*****	-0.5437
0.800	-0.6433	-1.3316	-1.2937	-0.7388	*****	*****	*****	*****	*****	*****
0.825	*****	-1.4291	-1.2155	-0.6723	-0.5022	*****	*****	*****	*****	-0.5022
0.850	-0.8770	-1.3835	-1.0598	-0.6610	-0.4950	*****	*****	*****	*****	-0.4950
0.875	*****	-1.3299	-0.9586	-0.6605	-0.4984	*****	*****	*****	*****	-0.4984
0.900	-1.1977	-1.2606	-0.9078	-0.6231	-0.4860	*****	*****	*****	*****	-0.4860
0.925	*****	-1.1918	-0.8504	-0.6271	-0.4676	*****	*****	*****	*****	-0.4676
0.950	-1.3478	-1.1425	-0.8079	-0.7056	-0.3914	*****	*****	*****	*****	-0.3914
0.975	*****	-1.1153	-0.7902	-0.6312	-0.3480	*****	*****	*****	*****	-0.3480
1.000	-1.3580	-1.4158	-0.9190	-1.0763	-0.5264	*****	*****	*****	*****	-0.5264
-0.200	$C_{p,l}$	0.2837	0.2631	0.2720	*****	*****	*****	*****	*****	-0.5224
-0.400	$C_{p,l}$	0.2802	0.2772	0.2475	0.0723	-0.6961	*****	*****	*****	-0.6961
-0.600	$C_{p,l}$	0.2990	0.2789	0.2465	0.1051	-0.6831	*****	*****	*****	-0.6831
-0.700	$C_{p,l}$	0.3160	0.2806	0.2536	0.1253	-0.6434	*****	*****	*****	-0.6434
-0.800	$C_{p,l}$	0.3319	*****	0.2528	0.1510	-0.5619	*****	*****	*****	-0.5619
-0.850	$C_{p,l}$	*****	0.3092	0.2623	0.1637	-0.5489	*****	*****	*****	-0.5489
-0.900	$C_{p,l}$	*****	0.3094	0.2708	0.1846	-0.5128	*****	*****	*****	-0.5128
-0.950	$C_{p,l}$	0.2303	0.2533	0.2454	0.1917	-0.1687	*****	*****	*****	-0.1687
-0.975	$C_{p,l}$	*****	0.1310	0.1598	0.1420	-0.0334	*****	*****	*****	-0.0334
-1.000	$C_{p,l}$	-1.3393	-1.2659	-1.1255	-1.1353	-0.5456	*****	*****	*****	-0.5456

Medium Radius L.E.
 Run No. = 31, Point No. = 633
 $C_N = 0.546$, $C_m = -0.0720$
 $\alpha = 12.5^\circ$, $M_\infty = 0.799$
 $R_{mac} = 119.9 \times 10^6$

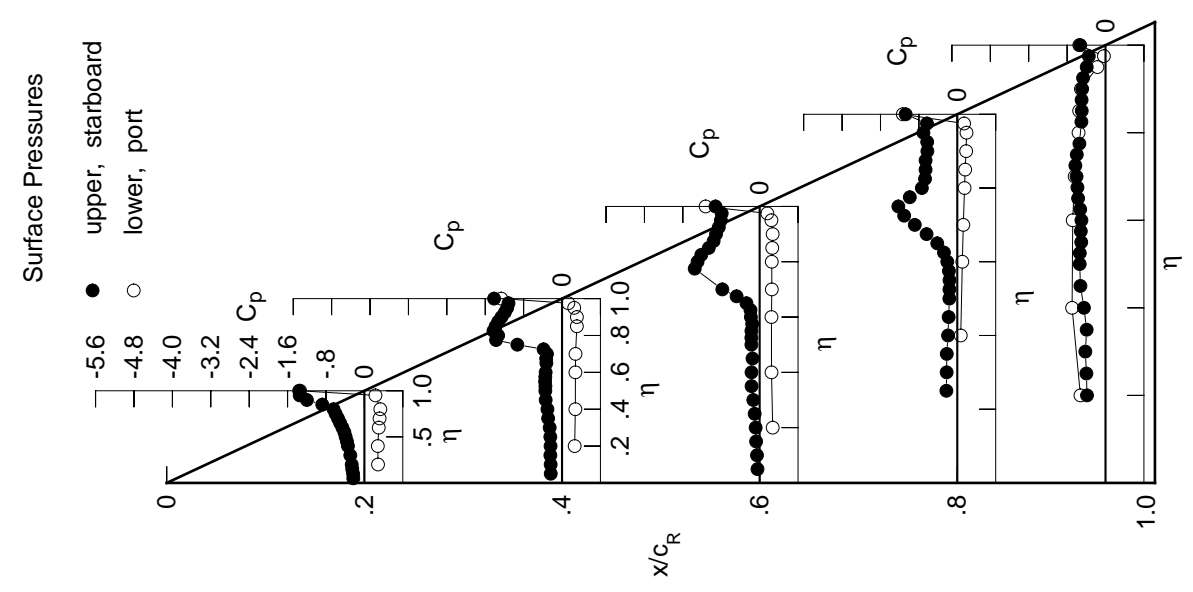
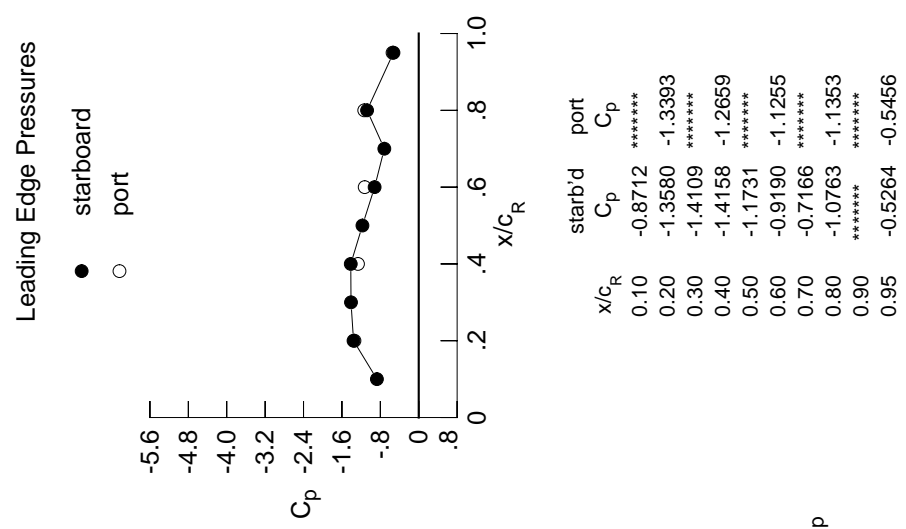

Table H1. Continued.

η	$x/c_R = .2$		$x/c_R = .4$		$x/c_R = .6$		$x/c_R = .8$		$x/c_R = .95$	
	$C_{p,u}$	$C_{p,l}$	$C_{p,u}$	$C_{p,l}$	$C_{p,u}$	$C_{p,l}$	$C_{p,u}$	$C_{p,l}$	$C_{p,u}$	$C_{p,l}$
0.050	-0.2611	-0.2815	-0.0741	*****	*****	*****	*****	*****	*****	*****
0.100	-0.2603	-0.2827	-0.0860	*****	*****	*****	*****	*****	*****	*****
0.150	-0.2790	-0.2861	-0.0997	*****	*****	*****	*****	*****	*****	*****
0.200	-0.2928	-0.2792	-0.1127	*****	*****	*****	*****	*****	*****	*****
0.250	*****	-0.2965	-0.1483	-0.2736	-0.2736	-0.3560	-0.3560	-0.3560	-0.3560	-0.3560
0.300	-0.3430	-0.3295	-0.1547	-0.2570	-0.2570	-0.3063	-0.3063	-0.3063	-0.3063	-0.3063
0.350	*****	-0.3249	-0.1594	-0.2442	-0.2442	-0.3498	-0.3498	-0.3498	-0.3498	-0.3498
0.400	-0.3838	-0.3136	-0.1643	-0.2254	-0.2254	-0.4345	-0.4345	-0.4345	-0.4345	-0.4345
0.450	-0.3973	-0.3119	-0.1425	-0.2169	-0.2169	-0.4835	-0.4835	-0.4835	-0.4835	-0.4835
0.500	-0.4200	-0.3056	-0.1863	-0.2147	-0.2147	-0.5067	-0.5067	-0.5067	-0.5067	-0.5067
0.525	*****	-0.3238	-0.1959	-0.2274	-0.2274	-0.5227	-0.5227	-0.5227	-0.5227	-0.5227
0.550	-0.4457	-0.3594	-0.2167	-0.2526	-0.2526	-0.5341	-0.5341	-0.5341	-0.5341	-0.5341
0.575	-0.3869	-0.2515	-0.3134	-0.5946	-0.5946	-0.5946	-0.5946	-0.5946	-0.5946	-0.5946
0.600	-0.4845	-0.4339	-0.4073	-0.4211	-0.4211	-0.6722	-0.6722	-0.6722	-0.6722	-0.6722
0.625	*****	*****	-0.5725	-0.5837	-0.5837	-0.7992	-0.7992	-0.7992	-0.7992	-0.7992
0.650	-0.5205	-0.6883	-0.8582	-0.7969	-0.7969	-0.9565	-0.9565	-0.9565	-0.9565	-0.9565
0.675	*****	-0.9210	-1.1140	-1.0258	-1.0258	-1.0863	-1.0863	-1.0863	-1.0863	-1.0863
0.700	-0.5359	-1.1363	-1.2588	-1.2105	-1.2105	-1.0256	-1.0256	-1.0256	-1.0256	-1.0256
0.725	*****	-1.2623	*****	-1.3343	-0.6319	-0.6319	-0.6319	-0.6319	-0.6319	-0.6319
0.750	-0.6135	-1.3095	*****	-1.2532	-0.5264	-0.5264	-0.5264	-0.5264	-0.5264	-0.5264
0.775	*****	-1.2993	-1.2980	-0.9597	-0.4848	-0.4848	-0.4848	-0.4848	-0.4848	-0.4848
0.800	-1.0627	-1.2725	-1.2117	-0.8151	*****	*****	*****	*****	*****	*****
0.825	*****	-1.2409	-1.1057	-0.7643	-0.4715	-0.4715	-0.4715	-0.4715	-0.4715	-0.4715
0.850	-1.3055	-1.2094	-0.9934	-0.7510	-0.4530	-0.4530	-0.4530	-0.4530	-0.4530	-0.4530
0.875	*****	-1.1805	-0.9441	-0.7425	-0.4577	-0.4577	-0.4577	-0.4577	-0.4577	-0.4577
0.900	-1.3678	-1.1537	-0.9059	-0.7186	-0.4517	-0.4517	-0.4517	-0.4517	-0.4517	-0.4517
0.925	*****	-1.1277	-0.8570	-0.6956	-0.4377	-0.4377	-0.4377	-0.4377	-0.4377	-0.4377
0.950	-1.3512	-1.0976	-0.8063	-0.7674	-0.3723	-0.3723	-0.3723	-0.3723	-0.3723	-0.3723
0.975	*****	-1.0858	-0.7831	-0.6896	-0.3096	-0.3096	-0.3096	-0.3096	-0.3096	-0.3096
1.000	-1.4455	-1.3492	-0.8800	-1.0451	-0.4269	-0.4269	-0.4269	-0.4269	-0.4269	-0.4269
-0.200	$C_{p,l}$	0.3160	0.2898	0.2924	*****	-0.4734	-0.4734	-0.4734	-0.4734	-0.4734
-0.400	$C_{p,l}$	0.3128	0.3049	0.2680	0.0918	-0.6631	-0.6631	-0.6631	-0.6631	-0.6631
-0.600	$C_{p,l}$	0.3312	0.3050	0.2677	0.1240	-0.6639	-0.6639	-0.6639	-0.6639	-0.6639
-0.700	$C_{p,l}$	0.3457	0.3070	0.2750	0.1450	-0.6278	-0.6278	-0.6278	-0.6278	-0.6278
-0.800	$C_{p,l}$	0.3558	*****	0.2739	0.1694	-0.5468	-0.5468	-0.5468	-0.5468	-0.5468
-0.850	$C_{p,l}$	*****	0.3297	0.2816	0.1826	-0.5327	-0.5327	-0.5327	-0.5327	-0.5327
-0.900	$C_{p,l}$	*****	0.3221	0.2847	0.2009	-0.4931	-0.4931	-0.4931	-0.4931	-0.4931
-0.950	$C_{p,l}$	0.2238	0.2492	0.2443	0.1973	-0.1601	-0.1601	-0.1601	-0.1601	-0.1601
-0.975	$C_{p,l}$	*****	0.1067	0.1414	0.1335	-0.0365	-0.0365	-0.0365	-0.0365	-0.0365
-1.000	$C_{p,l}$	-1.3922	-1.2401	-1.0392	-1.0066	-0.5100	-0.5100	-0.5100	-0.5100	-0.5100

Medium Radius L.E.

Run No. = 31, Point No. = 634

$C_N = 0.632$, $C_m = -0.0898$

$\alpha = 13.6^\circ$, $M_\infty = 0.799$

$R_{mac} = 120.0 \times 10^6$

Leading Edge Pressures

● starboard
○ port

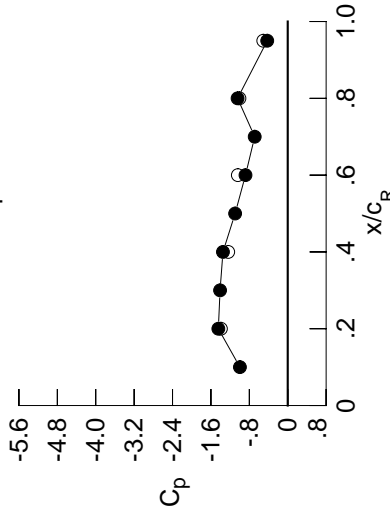

x/c_R	starb'd C_p	port C_p
0.10	-0.9960	*****
0.20	-1.4455	-1.3922
0.30	-1.4098	*****
0.40	-1.3492	-1.2401
0.50	-1.0961	*****
0.60	-0.8800	-1.0392
0.70	-0.6880	*****
0.80	-1.0451	-1.0066
0.90	*****	*****
0.95	-0.4269	-0.5100

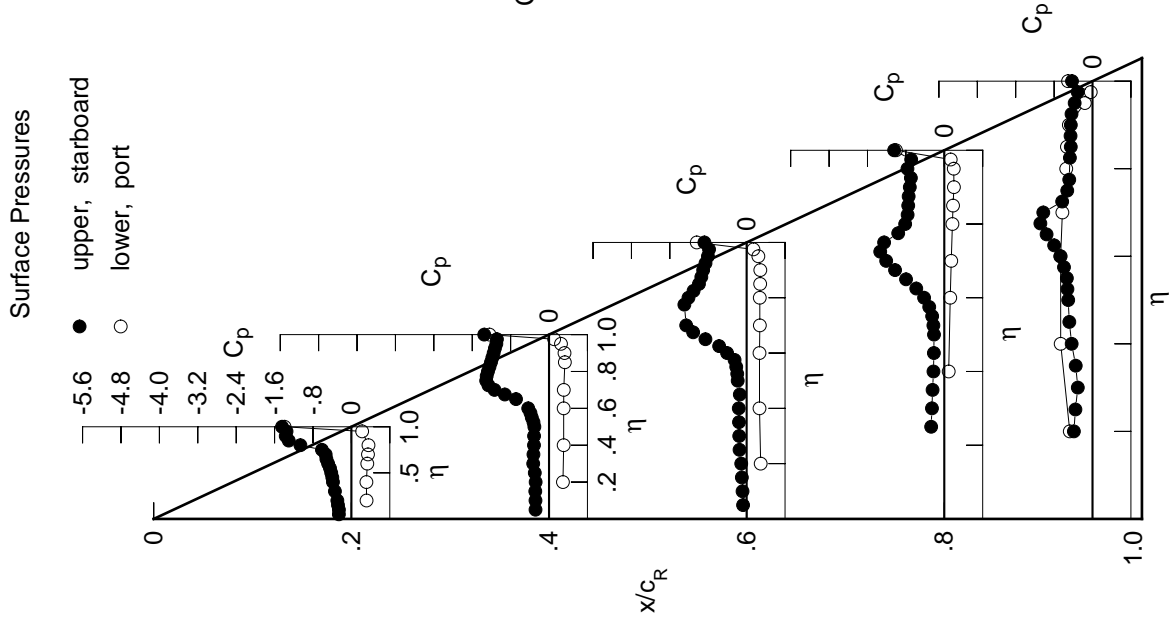

Table H1. Concluded.

η	$x/c_R = .2$		$x/c_R = .4$		$x/c_R = .6$		$x/c_R = .8$		$x/c_R = .95$	
	$C_{p,u}$	$C_{p,u}$	$C_{p,u}$	$C_{p,u}$	$C_{p,u}$	$C_{p,u}$	$C_{p,u}$	$C_{p,u}$	$C_{p,u}$	$C_{p,u}$
0.050	-0.2919	-0.3228	-0.0977	*****	*****	*****	*****	*****	*****	*****
0.100	-0.2879	-0.3247	-0.1083	*****	*****	*****	*****	*****	*****	*****
0.150	-0.3021	-0.3234	-0.1217	*****	*****	*****	*****	*****	*****	*****
0.200	-0.3165	-0.3183	-0.1378	*****	*****	*****	*****	*****	*****	-0.4059
0.250	*****	-0.3543	-0.1710	-0.2892	-0.2892	-0.3659	*****	*****	*****	-0.3659
0.300	-0.3963	-0.3534	-0.1695	-0.2692	-0.2692	-0.3217	*****	*****	*****	-0.3217
0.350	*****	-0.3483	-0.1785	-0.2571	-0.2571	-0.3649	*****	*****	*****	-0.3649
0.400	-0.4077	-0.3399	-0.1835	-0.2372	-0.2372	-0.4438	*****	*****	*****	-0.4438
0.450	-0.4123	-0.3431	-0.1605	-0.2320	-0.2320	-0.4898	*****	*****	*****	-0.4898
0.500	-0.4414	-0.3765	-0.2254	-0.2466	-0.2466	-0.5203	*****	*****	*****	-0.5203
0.525	*****	-0.4663	-0.2700	-0.2814	-0.2814	-0.5522	*****	*****	*****	-0.5522
0.550	-0.4604	-0.5825	-0.3557	-0.3449	-0.3449	-0.5880	*****	*****	*****	-0.5880
0.575	*****	-0.6862	-0.4807	-0.4588	-0.4588	-0.6811	*****	*****	*****	-0.6811
0.600	-0.4841	-0.7575	-0.7398	-0.6233	-0.6233	-0.7917	*****	*****	*****	-0.7917
0.625	*****	*****	-0.9556	-0.8265	-0.8265	-0.9391	*****	*****	*****	-0.9391
0.650	-0.4523	-0.9355	-1.1714	-1.0383	-1.0383	-1.1082	*****	*****	*****	-1.1082
0.675	*****	-1.0704	-1.3347	-1.2273	-1.2273	-1.1656	*****	*****	*****	-1.1656
0.700	-0.5436	-1.1986	-1.3832	-1.3556	-1.3556	-0.7565	*****	*****	*****	-0.7565
0.725	*****	-1.2814	*****	-1.3705	-1.3705	-0.6428	*****	*****	*****	-0.6428
0.750	-1.2618	-1.3135	*****	-1.3053	-1.3053	-0.5740	*****	*****	*****	-0.5740
0.775	*****	-1.3082	-1.2465	-1.0075	-1.0075	-0.5284	*****	*****	*****	-0.5284
0.800	-1.4066	-1.2900	-1.1767	-0.8587	-0.8587	*****	*****	*****	*****	*****
0.825	*****	-1.2677	-1.1075	-0.7964	-0.7964	-0.5017	*****	*****	*****	-0.5017
0.850	-1.4191	-1.2419	-1.0224	-0.7777	-0.7777	-0.4745	*****	*****	*****	-0.4745
0.875	*****	-1.2188	-0.9684	-0.7836	-0.7836	-0.4798	*****	*****	*****	-0.4798
0.900	-1.3860	-1.1944	-0.9216	-0.7662	-0.7662	-0.4700	*****	*****	*****	-0.4700
0.925	*****	-1.1681	-0.8871	-0.6888	-0.6888	-0.4555	*****	*****	*****	-0.4555
0.950	-1.3350	-1.1396	-0.8488	-0.7462	-0.7462	-0.3849	*****	*****	*****	-0.3849
0.975	*****	-1.1254	-0.8206	-0.6876	-0.6876	-0.3186	*****	*****	*****	-0.3186
1.000	-1.5191	-1.3084	-0.8739	-0.9719	-0.9719	-0.4141	*****	*****	*****	-0.4141
-0.200	$C_{p,l}$	$C_{p,l}$	$C_{p,l}$	$C_{p,l}$	$C_{p,l}$	$C_{p,l}$	$C_{p,l}$	$C_{p,l}$	$C_{p,l}$	$C_{p,l}$
-0.400	0.3460	0.3143	0.3100	*****	*****	-0.4876	*****	*****	*****	-0.4876
-0.600	0.3430	0.3305	0.2861	0.1052	0.1052	-0.6708	*****	*****	*****	-0.6708
-0.700	0.3609	0.3293	0.2858	0.1371	0.1371	-0.6677	*****	*****	*****	-0.6677
-0.800	0.3726	0.3307	0.2931	0.1574	0.1574	-0.6287	*****	*****	*****	-0.6287
-0.850	0.3769	*****	0.2910	0.1826	0.1826	-0.5443	*****	*****	*****	-0.5443
-0.900	*****	0.3472	0.2969	0.1944	0.1944	-0.5263	*****	*****	*****	-0.5263
-0.950	*****	0.3321	0.2953	0.2100	0.2100	-0.4828	*****	*****	*****	-0.4828
-0.975	0.2156	0.2441	0.2412	0.1956	0.1956	-0.1548	*****	*****	*****	-0.1548
-1.000	*****	0.0842	0.1242	0.1170	0.1170	-0.0415	*****	*****	*****	-0.0415
-1.000	-1.4366	-1.2012	-0.9482	-0.9562	-0.9562	-0.5082	*****	*****	*****	-0.5082

Medium Radius L.E.
 Run No. = 31, Point No. = 635
 $C_N = 0.690$, $C_m = -0.0953$
 $\alpha = 14.7^\circ$, $M_\infty = 0.798$
 $R_{mac} = 119.7 \times 10^6$

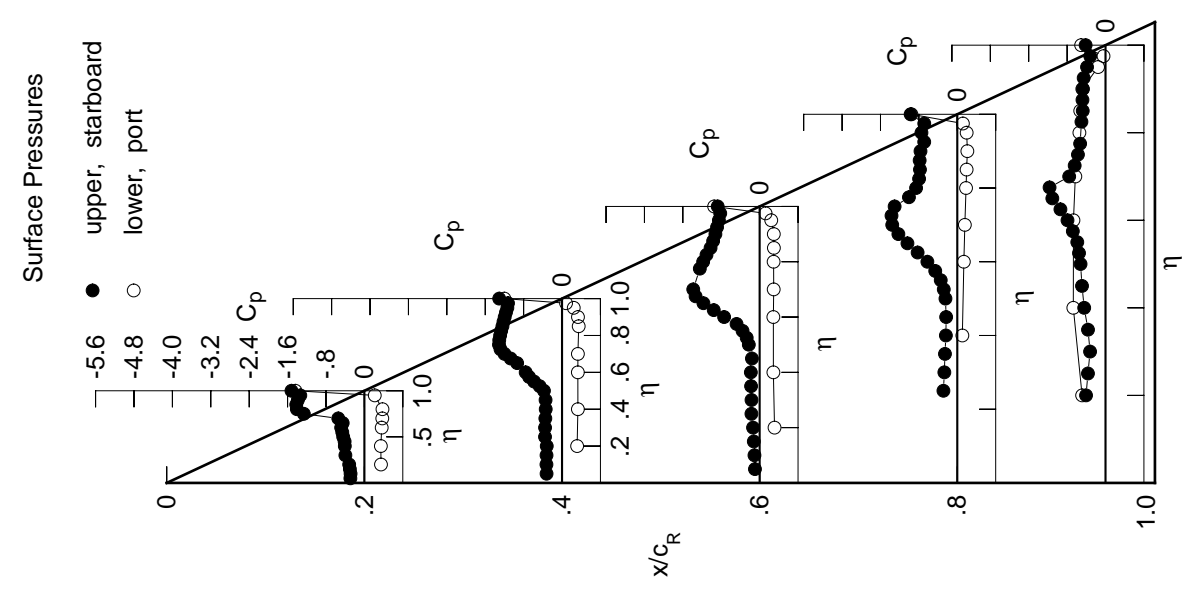
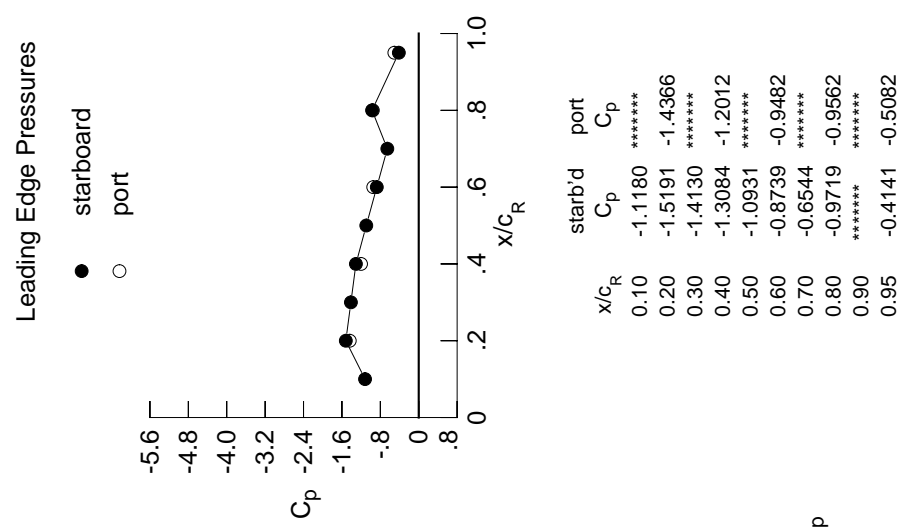
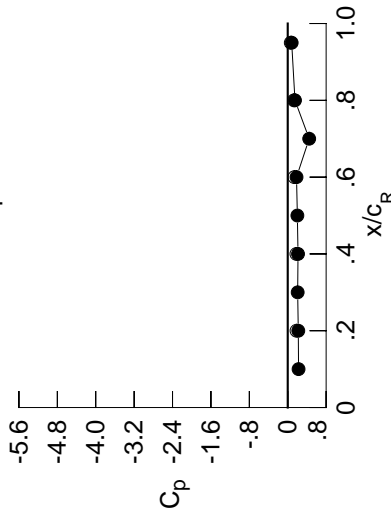
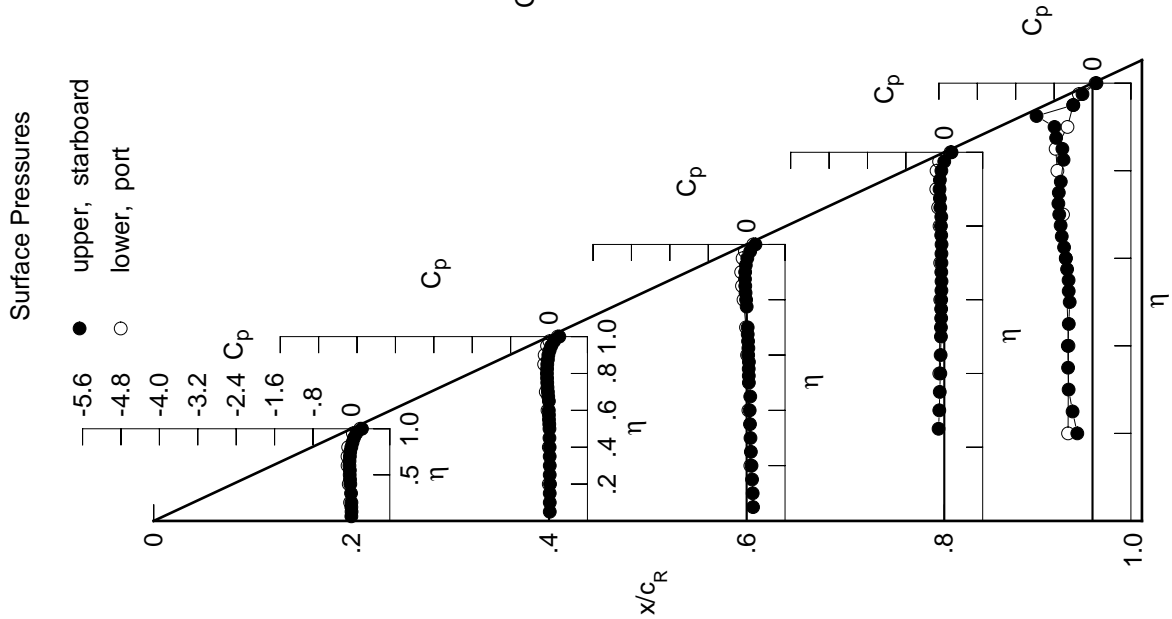

Table H2. Tabulations and Plots of Surface Pressure Coefficients.

η	$x/c_R = .2$		$x/c_R = .4$		$x/c_R = .6$		$x/c_R = .8$		$x/c_R = .95$	
	$C_{p,u}$	$C_{p,u}$	$C_{p,u}$	$C_{p,u}$	$C_{p,u}$	$C_{p,u}$	$C_{p,u}$	$C_{p,u}$	$C_{p,u}$	$C_{p,u}$
0.050	-0.0005	0.0154	0.1339	*****	*****	*****	*****	*****	*****	*****
0.100	0.0034	0.0155	0.1258	*****	*****	*****	*****	*****	*****	*****
0.150	-0.0007	0.0141	0.1125	*****	*****	*****	*****	*****	*****	*****
0.200	0.0005	0.0203	0.1019	*****	*****	*****	*****	*****	*****	*****
0.250	*****	0.0146	0.0884	-0.1195	-0.4155	*****	*****	*****	*****	*****
0.300	-0.0075	0.0153	0.0798	-0.1036	-0.4977	*****	*****	*****	*****	*****
0.350	*****	0.0138	0.0699	-0.0948	-0.5086	*****	*****	*****	*****	*****
0.400	-0.0228	0.0131	0.0632	-0.0821	-0.5146	*****	*****	*****	*****	*****
0.450	-0.0288	0.0090	0.0751	-0.0758	-0.4943	*****	*****	*****	*****	*****
0.500	-0.0355	0.0091	0.0461	-0.0693	-0.4748	*****	*****	*****	*****	*****
0.525	*****	0.0049	0.0450	-0.0697	-0.4960	*****	*****	*****	*****	*****
0.550	-0.0322	-0.0018	0.0428	-0.0652	-0.4982	*****	*****	*****	*****	*****
0.575	*****	-0.0021	0.0473	-0.0654	-0.5294	*****	*****	*****	*****	*****
0.600	-0.0404	-0.0046	0.0317	-0.0652	-0.5551	*****	*****	*****	*****	*****
0.625	*****	*****	0.0357	-0.0698	-0.5928	*****	*****	*****	*****	*****
0.650	-0.0393	-0.0033	0.0295	-0.0577	-0.6410	*****	*****	*****	*****	*****
0.675	*****	-0.0167	0.0223	-0.0626	-0.6640	*****	*****	*****	*****	*****
0.700	-0.0322	-0.0242	0.0217	-0.0593	-0.6930	*****	*****	*****	*****	*****
0.725	*****	-0.0317	*****	-0.0591	-0.7111	*****	*****	*****	*****	*****
0.750	-0.0246	-0.0374	*****	-0.0570	-0.7024	*****	*****	*****	*****	*****
0.775	*****	-0.0405	0.0009	-0.0636	-0.6605	*****	*****	*****	*****	*****
0.800	-0.0017	-0.0438	-0.0112	-0.0696	*****	*****	*****	*****	*****	*****
0.825	*****	-0.0406	-0.0221	-0.0625	-0.6034	*****	*****	*****	*****	*****
0.850	0.0221	-0.0370	-0.0292	-0.0837	-0.6279	*****	*****	*****	*****	*****
0.875	*****	-0.0242	-0.0344	-0.0915	-0.7575	*****	*****	*****	*****	*****
0.900	0.0525	-0.0145	-0.0308	-0.0989	-0.7913	*****	*****	*****	*****	*****
0.925	*****	0.0120	-0.0179	-0.0918	-1.1662	*****	*****	*****	*****	*****
0.950	0.1027	0.0477	0.0139	-0.0608	-0.3996	*****	*****	*****	*****	*****
0.975	*****	0.1050	0.0736	-0.0009	-0.2088	*****	*****	*****	*****	*****
1.000	0.2198	0.2143	0.1829	0.1510	0.0824	*****	*****	*****	*****	*****
	$C_{p,l}$	$C_{p,l}$	$C_{p,l}$	$C_{p,l}$	$C_{p,l}$	$C_{p,l}$	$C_{p,l}$	$C_{p,l}$	$C_{p,l}$	$C_{p,l}$
-0.200	-0.0275	-0.0058	0.0765	*****	-0.5094	*****	*****	*****	*****	*****
-0.400	-0.0550	-0.0050	0.0370	-0.1037	-0.5007	*****	*****	*****	*****	*****
-0.600	-0.0793	-0.0311	0.0091	-0.0847	-0.5580	*****	*****	*****	*****	*****
-0.700	-0.0811	-0.0683	-0.0137	-0.0854	-0.6144	*****	*****	*****	*****	*****
-0.800	-0.0675	*****	-0.0645	-0.0987	-0.7317	*****	*****	*****	*****	*****
-0.850	*****	-0.1026	-0.0965	-0.1279	-0.7682	*****	*****	*****	*****	*****
-0.900	*****	-0.0911	-0.1146	-0.1665	-0.5215	*****	*****	*****	*****	*****
-0.950	0.0309	-0.0416	-0.0843	-0.1609	-0.4027	*****	*****	*****	*****	*****
-0.975	*****	0.0090	-0.0360	-0.1082	-0.2840	*****	*****	*****	*****	*****
-1.000	0.1835	0.1809	0.1388	0.1300	0.0631	*****	*****	*****	*****	*****

Medium Radius L.E.
 Run No. = 34 , Point No. = 668
 $C_N = -0.033$, $C_m = 0.0057$
 $\alpha = -0.8^\circ$, $M_\infty = 0.832$
 $R_{mac} = 120.2 \times 10^6$



x/c_R	starb'd C_p	port C_p
0.10	0.2256	*****
0.20	0.2198	0.1835
0.30	0.2070	*****
0.40	0.2143	0.1809
0.50	0.2007	*****
0.60	0.1829	0.1388
0.70	0.4469	*****
0.80	0.1510	0.1300
0.90	*****	*****
0.95	0.0824	0.0631

Table H2. Continued.

η	$x/c_R = .2$		$x/c_R = .4$		$x/c_R = .6$		$x/c_R = .8$		$x/c_R = .95$	
	$C_{p,u}$	$C_{p,u}$	$C_{p,u}$	$C_{p,u}$	$C_{p,u}$	$C_{p,u}$	$C_{p,u}$	$C_{p,u}$	$C_{p,u}$	$C_{p,u}$
0.050	-0.0071	0.0092	0.1302	0.1302	0.1302	0.1302	0.1302	0.1302	0.1302	0.1302
0.100	-0.0035	0.0096	0.1215	0.1215	0.1215	0.1215	0.1215	0.1215	0.1215	0.1215
0.150	-0.0072	0.0082	0.1083	0.1083	0.1083	0.1083	0.1083	0.1083	0.1083	0.1083
0.200	-0.0061	0.0142	0.0978	0.0978	0.0978	0.0978	0.0978	0.0978	0.0978	0.0978
0.250	0.0000	0.0081	0.0838	0.0838	0.0838	0.0838	0.0838	0.0838	0.0838	0.0838
0.300	-0.0141	0.0090	0.0756	0.0756	0.0756	0.0756	0.0756	0.0756	0.0756	0.0756
0.350	0.0000	0.0074	0.0652	0.0652	0.0652	0.0652	0.0652	0.0652	0.0652	0.0652
0.400	-0.0306	0.0064	0.0584	0.0584	0.0584	0.0584	0.0584	0.0584	0.0584	0.0584
0.450	-0.0369	0.0025	0.0699	0.0699	0.0699	0.0699	0.0699	0.0699	0.0699	0.0699
0.500	-0.0442	0.0018	0.0411	0.0734	0.0734	0.0734	0.0734	0.0734	0.0734	0.0734
0.525	0.0000	-0.0019	0.0398	0.0732	0.0732	0.0732	0.0732	0.0732	0.0732	0.0732
0.550	-0.0416	-0.0099	0.0368	0.0696	0.0696	0.0696	0.0696	0.0696	0.0696	0.0696
0.575	0.0000	-0.0094	0.0419	0.0699	0.0699	0.0699	0.0699	0.0699	0.0699	0.0699
0.600	-0.0503	-0.0134	0.0252	0.0696	0.0696	0.0696	0.0696	0.0696	0.0696	0.0696
0.625	0.0000	0.0000	0.0295	0.0645	0.0645	0.0645	0.0645	0.0645	0.0645	0.0645
0.650	-0.0500	-0.0116	0.0222	0.0629	0.0629	0.0629	0.0629	0.0629	0.0629	0.0629
0.675	0.0000	-0.0246	0.0159	0.0670	0.0670	0.0670	0.0670	0.0670	0.0670	0.0670
0.700	-0.0443	-0.0341	0.0138	0.0650	0.0650	0.0650	0.0650	0.0650	0.0650	0.0650
0.725	0.0000	-0.0412	0.0000	0.0641	0.0641	0.0641	0.0641	0.0641	0.0641	0.0641
0.750	-0.0369	-0.0481	0.0000	0.0638	0.0638	0.0638	0.0638	0.0638	0.0638	0.0638
0.775	0.0000	-0.0519	-0.0081	0.0706	0.0706	0.0706	0.0706	0.0706	0.0706	0.0706
0.800	-0.0153	-0.0564	-0.0209	0.0768	0.0768	0.0768	0.0768	0.0768	0.0768	0.0768
0.825	0.0000	-0.0545	-0.0337	0.0699	0.0699	0.0699	0.0699	0.0699	0.0699	0.0699
0.850	0.0083	-0.0515	-0.0419	0.0932	0.0932	0.0932	0.0932	0.0932	0.0932	0.0932
0.875	0.0000	-0.0402	-0.0493	0.1030	0.1030	0.1030	0.1030	0.1030	0.1030	0.1030
0.900	0.0382	-0.0305	-0.0466	0.1126	0.1126	0.1126	0.1126	0.1126	0.1126	0.1126
0.925	0.0000	-0.0061	-0.0362	0.1083	0.1083	0.1083	0.1083	0.1083	0.1083	0.1083
0.950	0.0883	0.0301	-0.0050	0.0794	0.0794	0.0794	0.0794	0.0794	0.0794	0.0794
0.975	0.0000	0.0859	0.0530	0.0222	0.0222	0.0222	0.0222	0.0222	0.0222	0.0222
1.000	0.2242	0.2217	0.2008	0.1644	0.1644	0.1644	0.1644	0.1644	0.1644	0.1644
$C_{p,l}$	$C_{p,l}$	$C_{p,l}$	$C_{p,l}$	$C_{p,l}$	$C_{p,l}$	$C_{p,l}$	$C_{p,l}$	$C_{p,l}$	$C_{p,l}$	$C_{p,l}$
-0.200	-0.0213	0.0004	0.0805	0.0805	0.0805	0.0805	0.0805	0.0805	0.0805	0.0805
-0.400	-0.0472	0.0015	0.0417	0.0993	0.0993	0.0993	0.0993	0.0993	0.0993	0.0993
-0.600	-0.0694	-0.0233	0.0160	0.0800	0.0800	0.0800	0.0800	0.0800	0.0800	0.0800
-0.700	-0.0694	-0.0583	-0.0071	0.0790	0.0790	0.0790	0.0790	0.0790	0.0790	0.0790
-0.800	-0.0542	0.0000	-0.0531	0.0905	0.0905	0.0905	0.0905	0.0905	0.0905	0.0905
-0.850	0.0000	-0.0867	-0.0821	0.1179	0.1179	0.1179	0.1179	0.1179	0.1179	0.1179
-0.900	0.0000	-0.0720	-0.0968	0.1510	0.1510	0.1510	0.1510	0.1510	0.1510	0.1510
-0.950	0.0480	-0.0200	-0.0610	0.1382	0.1382	0.1382	0.1382	0.1382	0.1382	0.1382
-0.975	0.0000	0.0343	-0.0099	0.0817	0.0817	0.0817	0.0817	0.0817	0.0817	0.0817
-1.000	0.1905	0.1928	0.1545	0.1504	0.1504	0.1504	0.1504	0.1504	0.1504	0.1504

Medium Radius L.E.
 Run No. = 34 , Point No. = 669
 $C_N = -0.019$, $C_m = 0.0030$
 $\alpha = -0.4^\circ$, $M_\infty = 0.831$
 $R_{mac} = 120.2 \times 10^6$

Leading Edge Pressures

● starboard
 ○ port

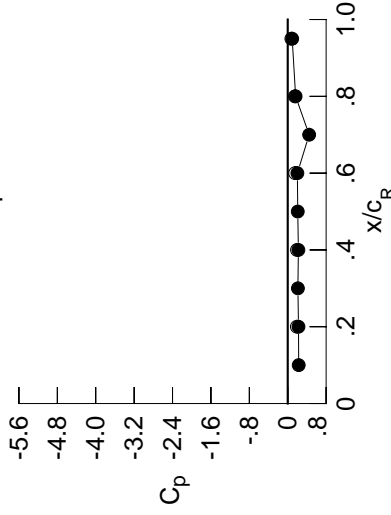

x/c_R	starb'd C_p	port C_p
0.10	0.2284	0.1905
0.20	0.2242	0.1905
0.30	0.2119	0.1928
0.40	0.2217	0.1928
0.50	0.2090	0.1545
0.60	0.2008	0.1545
0.70	0.4461	0.1504
0.80	0.1644	0.1504
0.90	0.0930	0.0760
0.95	0.0930	0.0760

Surface Pressures

● upper, starboard
 ○ lower, port

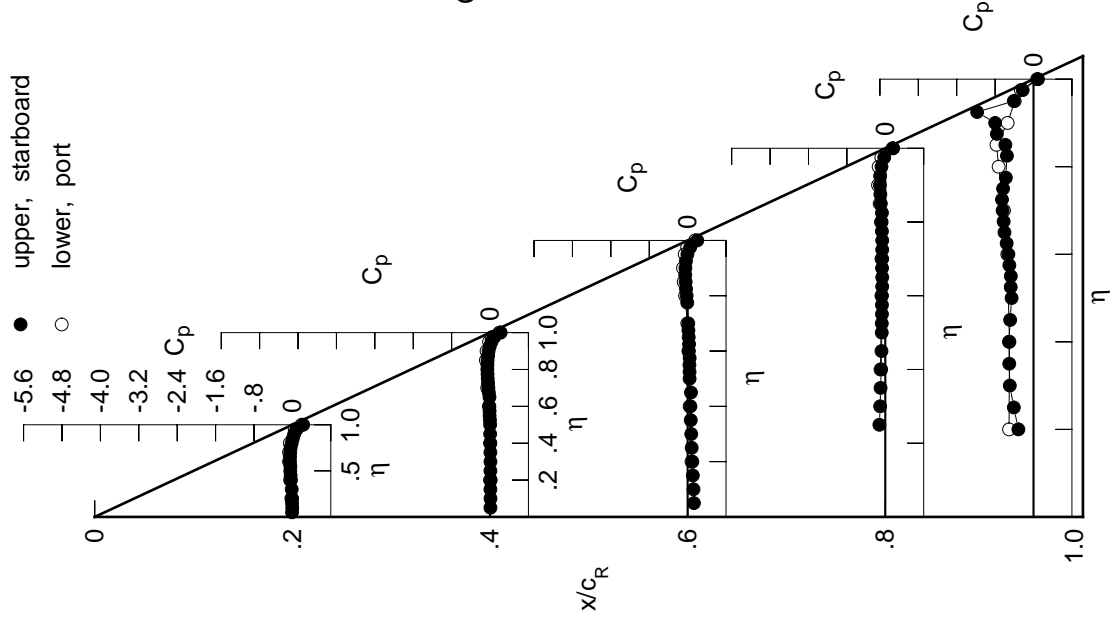

Table H2. Continued.

η	$x/c_R = .2$		$x/c_R = .4$		$x/c_R = .6$		$x/c_R = .8$		$x/c_R = .95$	
	$C_{p,u}$	$C_{p,u}$	$C_{p,u}$	$C_{p,u}$	$C_{p,u}$	$C_{p,u}$	$C_{p,u}$	$C_{p,u}$	$C_{p,u}$	$C_{p,u}$
0.050	-0.0273	-0.0088	0.1174	*****	*****	*****	*****	*****	*****	*****
0.100	-0.0234	-0.0081	0.1094	*****	*****	*****	*****	*****	*****	*****
0.150	-0.0277	-0.0097	0.0953	*****	*****	*****	*****	*****	*****	*****
0.200	-0.0266	-0.0039	0.0853	*****	*****	*****	*****	*****	*****	-0.2939
0.250	*****	-0.0099	0.0700	-0.1345	-0.3877	*****	*****	*****	*****	-0.3877
0.300	-0.0357	-0.0095	0.0615	-0.1190	-0.4789	*****	*****	*****	*****	-0.4789
0.350	*****	-0.0121	0.0499	-0.1103	-0.4963	*****	*****	*****	*****	-0.4963
0.400	-0.0544	-0.0130	0.0435	-0.0985	-0.5039	*****	*****	*****	*****	-0.5039
0.450	-0.0622	-0.0179	0.0538	-0.0923	-0.4778	*****	*****	*****	*****	-0.4778
0.500	-0.0708	-0.0195	0.0241	-0.0867	-0.4442	*****	*****	*****	*****	-0.4442
0.525	*****	-0.0242	0.0223	-0.0869	-0.4613	*****	*****	*****	*****	-0.4613
0.550	-0.0704	-0.0326	0.0189	-0.0834	-0.4588	*****	*****	*****	*****	-0.4588
0.575	*****	-0.0334	0.0235	-0.0843	-0.4909	*****	*****	*****	*****	-0.4909
0.600	-0.0810	-0.0376	0.0060	-0.0851	-0.5117	*****	*****	*****	*****	-0.5117
0.625	*****	*****	0.0087	-0.0807	-0.5447	*****	*****	*****	*****	-0.5447
0.650	-0.0830	-0.0379	0.0014	-0.0795	-0.5815	*****	*****	*****	*****	-0.5815
0.675	*****	-0.0530	-0.0065	-0.0850	-0.5852	*****	*****	*****	*****	-0.5852
0.700	-0.0796	-0.0636	-0.0096	-0.0836	-0.5853	*****	*****	*****	*****	-0.5853
0.725	*****	-0.0740	*****	-0.0839	-0.5698	*****	*****	*****	*****	-0.5698
0.750	-0.0748	-0.0827	*****	-0.0843	-0.5107	*****	*****	*****	*****	-0.5107
0.775	*****	-0.0900	-0.0369	-0.0935	-0.4244	*****	*****	*****	*****	-0.4244
0.800	-0.0562	-0.0969	-0.0539	-0.1027	*****	*****	*****	*****	*****	*****
0.825	*****	-0.0991	-0.0705	-0.0966	-0.4404	*****	*****	*****	*****	-0.4404
0.850	-0.0350	-0.0991	-0.0840	-0.1258	-0.4778	*****	*****	*****	*****	-0.4778
0.875	*****	-0.0918	-0.0969	-0.1417	-0.7512	*****	*****	*****	*****	-0.7512
0.900	-0.0084	-0.0859	-0.1011	-0.1596	-0.7986	*****	*****	*****	*****	-0.7986
0.925	*****	-0.0658	-0.0962	-0.1638	-1.1518	*****	*****	*****	*****	-1.1518
0.950	0.0394	-0.0332	-0.0730	-0.1447	-0.4480	*****	*****	*****	*****	-0.4480
0.975	*****	0.0182	-0.0210	-0.0974	-0.2827	*****	*****	*****	*****	-0.2827
1.000	0.2194	0.2133	0.1973	0.1558	0.0876	*****	*****	*****	*****	0.0876
	$C_{p,l}$	$C_{p,l}$	$C_{p,l}$	$C_{p,l}$	$C_{p,l}$	$C_{p,l}$	$C_{p,l}$	$C_{p,l}$	$C_{p,l}$	$C_{p,l}$
-0.200	-0.0005	0.0183	0.0936	*****	-0.5243	*****	*****	*****	*****	-0.5243
-0.400	-0.0236	0.0208	0.0568	-0.0870	-0.5375	*****	*****	*****	*****	-0.5375
-0.600	-0.0390	0.0009	0.0348	-0.0656	-0.6082	*****	*****	*****	*****	-0.6082
-0.700	-0.0339	-0.0284	0.0159	-0.0612	-0.6863	*****	*****	*****	*****	-0.6863
-0.800	-0.0129	*****	-0.0207	-0.0655	-0.7201	*****	*****	*****	*****	-0.7201
-0.850	*****	-0.0402	-0.0412	-0.0850	-0.7522	*****	*****	*****	*****	-0.7522
-0.900	*****	-0.0179	-0.0445	-0.1047	-0.6360	*****	*****	*****	*****	-0.6360
-0.950	0.0977	0.0409	0.0036	-0.0738	-0.3554	*****	*****	*****	*****	-0.3554
-0.975	*****	0.1003	0.0614	-0.0082	-0.2098	*****	*****	*****	*****	-0.2098
-1.000	0.1911	0.1939	0.1579	0.1587	0.0851	*****	*****	*****	*****	0.0851

Medium Radius L.E.
 Run No. = 34 , Point No. = 670
 $C_N = 0.023$, $C_m = -0.0033$
 $\alpha = 0.6^\circ$, $M_\infty = 0.830$
 $R_{mac} = 120.1 \times 10^6$

Leading Edge Pressures

● starboard
 ○ port

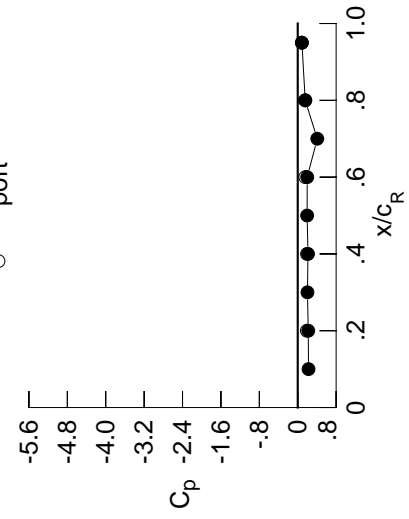

x/c_R	starb'd C_p	port C_p
0.10	0.2248	*****
0.20	0.2194	0.1911
0.30	0.2028	*****
0.40	0.2133	0.1939
0.50	0.1960	*****
0.60	0.1973	0.1579
0.70	0.4073	*****
0.80	0.1558	0.1587
0.90	*****	*****
0.95	0.0876	0.0851

Surface Pressures

● upper, starboard
 ○ lower, port

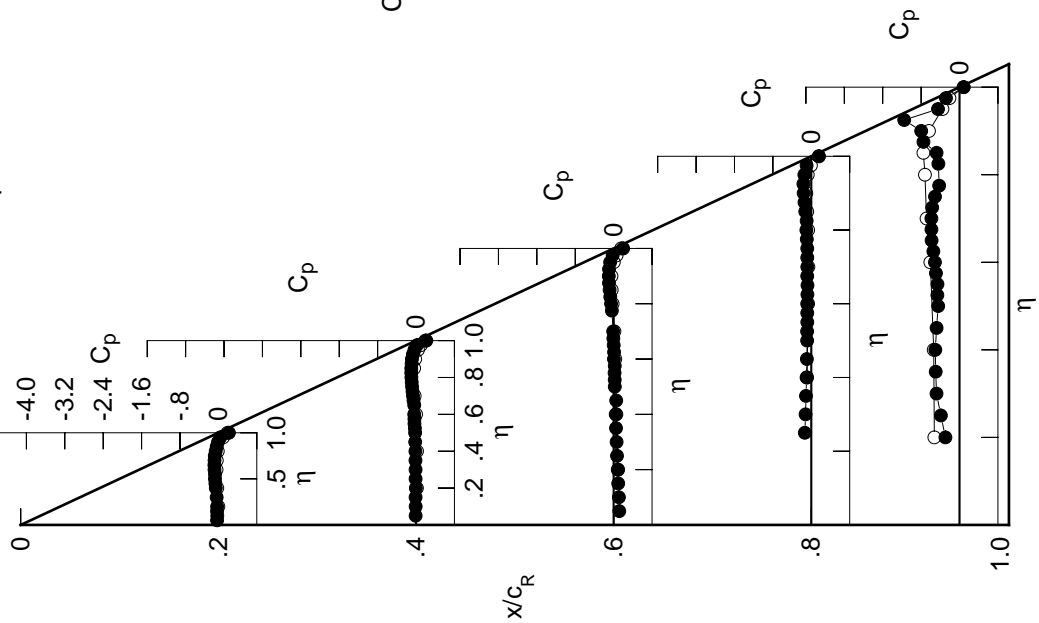

Table H2. Continued.

η	x/c_R .2	x/c_R .4	x/c_R .6	x/c_R .8	x/c_R .95
	$C_{p,u}$	$C_{p,u}$	$C_{p,u}$	$C_{p,u}$	$C_{p,u}$
0.050	-0.0486	-0.0270	0.1048	*****	*****
0.100	-0.0452	-0.0266	0.0963	*****	*****
0.150	-0.0490	-0.0290	0.0825	*****	*****
0.200	-0.0483	-0.0225	0.0712	*****	-0.2771
0.250	*****	-0.0290	0.0565	-0.1456	-0.3666
0.300	-0.0572	-0.0290	0.0474	-0.1299	-0.4636
0.350	*****	-0.0319	0.0353	-0.1221	-0.4910
0.400	-0.0786	-0.0336	0.0279	-0.1096	-0.5073
0.450	-0.0881	-0.0390	0.0365	-0.1041	-0.4823
0.500	-0.0985	-0.0420	0.0068	-0.0995	-0.4438
0.525	*****	-0.0475	0.0042	-0.1002	-0.4577
0.550	-0.1005	-0.0566	-0.0005	-0.0973	-0.4501
0.575	*****	-0.0579	0.0045	-0.0985	-0.4787
0.600	-0.1134	-0.0639	-0.0135	-0.1002	-0.4943
0.625	*****	*****	-0.0119	-0.0966	-0.5206
0.650	-0.1191	-0.0653	-0.0204	-0.0958	-0.5462
0.675	*****	-0.0828	-0.0300	-0.1027	-0.5358
0.700	-0.1182	-0.0960	-0.0344	-0.1024	-0.5172
0.725	*****	-0.1086	*****	-0.1041	-0.4781
0.750	-0.1164	-0.1205	*****	-0.1059	-0.4007
0.775	*****	-0.1310	-0.0688	-0.1172	-0.3112
0.800	-0.1018	-0.1422	-0.0893	-0.1298	*****
0.825	*****	-0.1479	-0.1111	-0.1259	-0.3444
0.850	-0.0847	-0.1530	-0.1309	-0.1611	-0.3761
0.875	*****	-0.1500	-0.1505	-0.1849	-0.6449
0.900	-0.0632	-0.1495	-0.1629	-0.2127	-0.7488
0.925	*****	-0.1356	-0.1667	-0.2270	-1.0966
0.950	-0.0201	-0.1085	-0.1537	-0.2217	-0.4925
0.975	*****	-0.0706	-0.1151	-0.1910	-0.3535
1.000	0.1847	0.1517	0.1164	0.0655	0.0255
	$C_{p,l}$	$C_{p,l}$	$C_{p,l}$	$C_{p,l}$	$C_{p,l}$
-0.200	0.0221	0.0374	0.1086	*****	-0.5336
-0.400	0.0016	0.0416	0.0732	-0.0736	-0.5708
-0.600	-0.0076	0.0261	0.0543	-0.0492	-0.6430
-0.700	0.0019	0.0019	0.0401	-0.0423	-0.7097
-0.800	0.0277	*****	0.0109	-0.0404	-0.7028
-0.850	*****	0.0046	-0.0013	-0.0530	-0.7270
-0.900	*****	0.0327	0.0048	-0.0605	-0.7604
-0.950	0.1412	0.0938	0.0607	-0.0166	-0.3227
-0.975	*****	0.1522	0.1199	0.0514	-0.1619
-1.000	0.1586	0.1423	0.0844	0.0870	0.0360

Medium Radius L.E.
 Run No. = 34, Point No. = 671
 $C_N = 0.066$, $C_m = -0.0097$
 $\alpha = 1.7^\circ$, $M_\infty = 0.830$
 $R_{mac} = 120.1 \times 10^6$

Leading Edge Pressures

● starboard
 ○ port

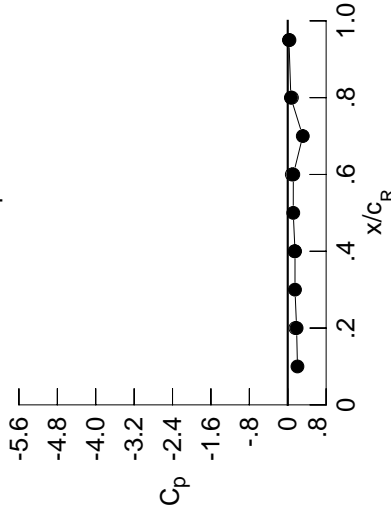

x/c_R	starb'd C_p	port C_p
0.10	0.2026	*****
0.20	0.1847	0.1586
0.30	0.1511	*****
0.40	0.1517	0.1423
0.50	0.1149	*****
0.60	0.1164	0.0844
0.70	0.3136	*****
0.80	0.0655	0.0870
0.90	*****	*****
0.95	0.0255	0.0360

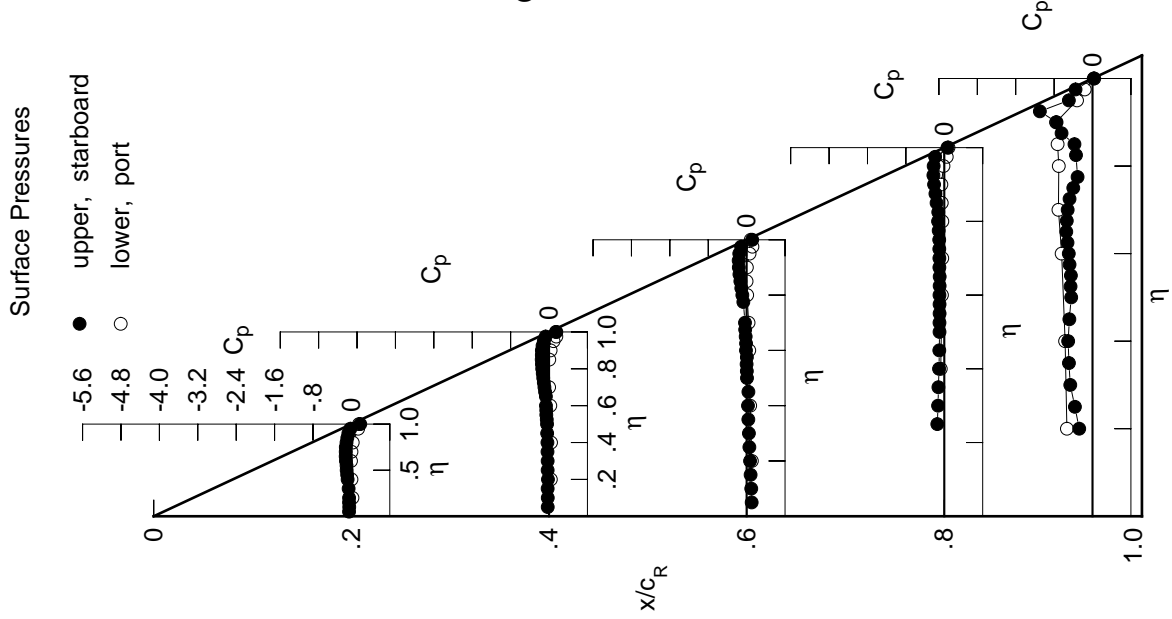

Table H2. Continued.

η	$x/c_R = .2$		$x/c_R = .4$		$x/c_R = .6$		$x/c_R = .8$		$x/c_R = .95$	
	$C_{p,u}$	$C_{p,l}$	$C_{p,u}$	$C_{p,l}$	$C_{p,u}$	$C_{p,l}$	$C_{p,u}$	$C_{p,l}$	$C_{p,u}$	$C_{p,l}$
0.050	-0.0685	-0.0450	0.0921	*****	*****	*****	*****	*****	*****	*****
0.100	-0.0659	-0.0447	0.0833	*****	*****	*****	*****	*****	*****	*****
0.150	-0.0694	-0.0459	0.0698	*****	*****	*****	*****	*****	*****	*****
0.200	-0.0696	-0.0412	0.0579	*****	*****	*****	*****	*****	*****	*****
0.250	*****	-0.0477	0.0427	-0.1575	-0.1575	-0.3520	-0.3520	-0.3520	-0.3520	-0.3520
0.300	-0.0793	-0.0479	0.0330	-0.1419	-0.1419	-0.4476	-0.4476	-0.4476	-0.4476	-0.4476
0.350	*****	-0.0519	0.0203	-0.1340	-0.1340	-0.4843	-0.4843	-0.4843	-0.4843	-0.4843
0.400	-0.1030	-0.0538	0.0122	-0.1225	-0.1225	-0.5115	-0.5115	-0.5115	-0.5115	-0.5115
0.450	-0.1140	-0.0606	0.0199	-0.1174	-0.1174	-0.4968	-0.4968	-0.4968	-0.4968	-0.4968
0.500	-0.1263	-0.0641	-0.0108	-0.1137	-0.1137	-0.4628	-0.4628	-0.4628	-0.4628	-0.4628
0.525	*****	-0.0709	-0.0137	-0.1147	-0.1147	-0.4793	-0.4793	-0.4793	-0.4793	-0.4793
0.550	-0.1304	-0.0808	-0.0197	-0.1119	-0.1119	-0.4722	-0.4722	-0.4722	-0.4722	-0.4722
0.575	*****	-0.0832	-0.0153	-0.1139	-0.1139	-0.4998	-0.4998	-0.4998	-0.4998	-0.4998
0.600	-0.1461	-0.0903	-0.0340	-0.1161	-0.1161	-0.5098	-0.5098	-0.5098	-0.5098	-0.5098
0.625	*****	*****	-0.0333	-0.1131	-0.1131	-0.5260	-0.5260	-0.5260	-0.5260	-0.5260
0.650	-0.1547	-0.0942	-0.0420	-0.1133	-0.1133	-0.5363	-0.5363	-0.5363	-0.5363	-0.5363
0.675	*****	-0.1132	-0.0538	-0.1216	-0.1216	-0.5073	-0.5073	-0.5073	-0.5073	-0.5073
0.700	-0.1576	-0.1288	-0.0597	-0.1223	-0.1223	-0.4632	-0.4632	-0.4632	-0.4632	-0.4632
0.725	*****	-0.1441	*****	-0.1254	-0.1254	-0.4074	-0.4074	-0.4074	-0.4074	-0.4074
0.750	-0.1597	-0.1593	*****	-0.1293	-0.1293	-0.3300	-0.3300	-0.3300	-0.3300	-0.3300
0.775	*****	-0.1740	-0.1010	-0.1427	-0.1427	-0.2450	-0.2450	-0.2450	-0.2450	-0.2450
0.800	-0.1491	-0.1889	-0.1257	-0.1587	-0.1587	*****	*****	*****	*****	*****
0.825	*****	-0.1994	-0.1524	-0.1561	-0.1561	-0.2859	-0.2859	-0.2859	-0.2859	-0.2859
0.850	-0.1369	-0.2093	-0.1797	-0.1981	-0.1981	-0.3047	-0.3047	-0.3047	-0.3047	-0.3047
0.875	*****	-0.2118	-0.2069	-0.2297	-0.2297	-0.4968	-0.4968	-0.4968	-0.4968	-0.4968
0.900	-0.1211	-0.2179	-0.2288	-0.2684	-0.2684	-0.6922	-0.6922	-0.6922	-0.6922	-0.6922
0.925	*****	-0.2119	-0.2430	-0.2951	-0.2951	-1.0170	-1.0170	-1.0170	-1.0170	-1.0170
0.950	-0.0864	-0.1939	-0.2437	-0.3061	-0.3061	-0.5404	-0.5404	-0.5404	-0.5404	-0.5404
0.975	*****	-0.1722	-0.2242	-0.2972	-0.2972	-0.4314	-0.4314	-0.4314	-0.4314	-0.4314
1.000	0.1166	0.0356	-0.0068	-0.1009	-0.1009	-0.0916	-0.0916	-0.0916	-0.0916	-0.0916
-0.200	$C_{p,l}$	$C_{p,l}$	$C_{p,l}$	$C_{p,l}$	$C_{p,l}$	$C_{p,l}$	$C_{p,l}$	$C_{p,l}$	$C_{p,l}$	$C_{p,l}$
-0.400	0.0435	0.0557	0.1213	*****	*****	-0.5420	-0.5420	-0.5420	-0.5420	-0.5420
-0.600	0.0253	0.0611	0.0877	-0.0609	-0.0609	-0.6044	-0.6044	-0.6044	-0.6044	-0.6044
-0.700	0.0215	0.0496	0.0711	-0.0348	-0.0348	-0.6709	-0.6709	-0.6709	-0.6709	-0.6709
-0.800	0.0352	0.0306	0.0618	-0.0254	-0.0254	-0.7239	-0.7239	-0.7239	-0.7239	-0.7239
-0.850	0.0642	*****	0.0387	-0.0179	-0.0179	-0.6867	-0.6867	-0.6867	-0.6867	-0.6867
-0.900	*****	0.0453	0.0335	-0.0241	-0.0241	-0.7050	-0.7050	-0.7050	-0.7050	-0.7050
-0.950	*****	0.0768	0.0472	-0.0215	-0.0215	-0.7384	-0.7384	-0.7384	-0.7384	-0.7384
-0.975	0.1751	0.1366	0.1062	0.0309	-0.2958	-0.2958	-0.2958	-0.2958	-0.2958	-0.2958
-1.000	0.0937	0.0372	-0.0671	-0.0600	-0.0619	-0.0619	-0.0619	-0.0619	-0.0619	-0.0619

Medium Radius L.E.
 Run No. = 34 , Point No. = 672
 $C_N = 0.107$, $C_m = -0.0157$
 $\alpha = 2.8^\circ$, $M_\infty = 0.830$
 $R_{mac} = 120.1 \times 10^6$

Leading Edge Pressures

● starboard
 ○ port

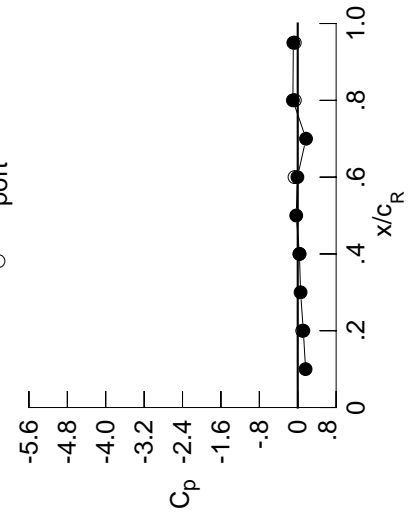

x/c_R	starb'd C_p	port C_p
0.10	0.1634	*****
0.20	0.1166	0.0937
0.30	0.0593	*****
0.40	0.0356	0.0372
0.50	-0.0309	*****
0.60	-0.0068	-0.0671
0.70	0.1725	*****
0.80	-0.1009	-0.0600
0.90	*****	*****
0.95	-0.0916	-0.0619

Surface Pressures
 ● upper, starboard
 ○ lower, port

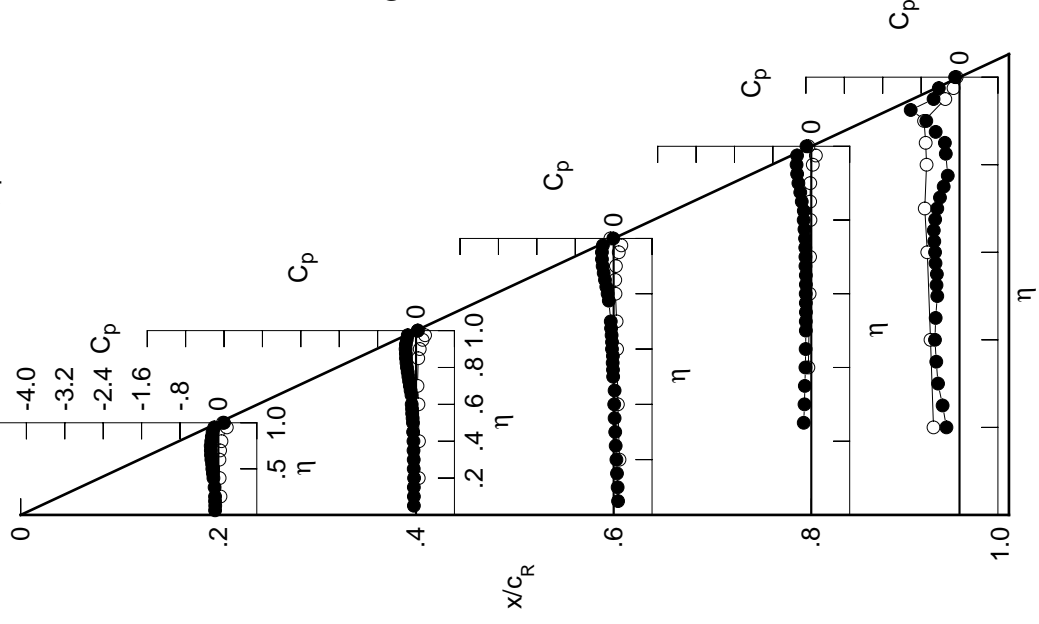

Table H2. Continued.

η	$x/c_R = .2$		$x/c_R = .4$		$x/c_R = .6$		$x/c_R = .8$		$x/c_R = .95$	
	$C_{p,u}$	$C_{p,l}$	$C_{p,u}$	$C_{p,l}$	$C_{p,u}$	$C_{p,l}$	$C_{p,u}$	$C_{p,l}$	$C_{p,u}$	$C_{p,l}$
0.050	-0.0849	-0.0606	0.0824	*****	*****	*****	*****	*****	*****	*****
0.100	-0.0829	-0.0598	0.0739	*****	*****	*****	*****	*****	*****	*****
0.150	-0.0870	-0.0628	0.0599	*****	*****	*****	*****	*****	*****	*****
0.200	-0.0875	-0.0565	0.0482	*****	*****	*****	*****	*****	*****	-0.2684
0.250	*****	-0.0638	0.0325	-0.1667	-0.3382	*****	*****	*****	*****	*****
0.300	-0.0975	-0.0646	0.0223	-0.1515	-0.4253	*****	*****	*****	*****	*****
0.350	*****	-0.0692	0.0089	-0.1436	-0.4711	*****	*****	*****	*****	*****
0.400	-0.1243	-0.0717	0.0000	-0.1324	-0.5163	*****	*****	*****	*****	*****
0.450	-0.1365	-0.0801	0.0072	-0.1277	-0.5233	*****	*****	*****	*****	*****
0.500	-0.1507	-0.0843	-0.0243	-0.1249	-0.5089	*****	*****	*****	*****	*****
0.525	*****	-0.0917	-0.0280	-0.1263	-0.5303	*****	*****	*****	*****	*****
0.550	-0.1571	-0.1029	-0.0346	-0.1246	-0.5250	*****	*****	*****	*****	*****
0.575	*****	-0.1060	-0.0310	-0.1261	-0.5484	*****	*****	*****	*****	*****
0.600	-0.1760	-0.1138	-0.0512	-0.1301	-0.5487	*****	*****	*****	*****	*****
0.625	*****	*****	-0.0512	-0.1280	-0.5469	*****	*****	*****	*****	*****
0.650	-0.1885	-0.1203	-0.0609	-0.1282	-0.5332	*****	*****	*****	*****	*****
0.675	*****	-0.1406	-0.0737	-0.1378	-0.4763	*****	*****	*****	*****	*****
0.700	-0.1944	-0.1595	-0.0811	-0.1392	-0.4175	*****	*****	*****	*****	*****
0.725	*****	-0.1774	*****	-0.1448	-0.3622	*****	*****	*****	*****	*****
0.750	-0.2007	-0.1955	*****	-0.1494	-0.2880	*****	*****	*****	*****	*****
0.775	*****	-0.2141	-0.1309	-0.1659	-0.2024	*****	*****	*****	*****	*****
0.800	-0.1952	-0.2337	-0.1607	-0.1848	*****	*****	*****	*****	*****	*****
0.825	*****	-0.2497	-0.1929	-0.1861	-0.2515	*****	*****	*****	*****	*****
0.850	-0.1887	-0.2645	-0.2266	-0.2330	-0.2632	*****	*****	*****	*****	*****
0.875	*****	-0.2745	-0.2627	-0.2742	-0.4055	*****	*****	*****	*****	*****
0.900	-0.1803	-0.2874	-0.2955	-0.3240	-0.6582	*****	*****	*****	*****	*****
0.925	*****	-0.2915	-0.3221	-0.3658	-0.9077	*****	*****	*****	*****	*****
0.950	-0.1572	-0.2847	-0.3399	-0.3952	-0.5923	*****	*****	*****	*****	*****
0.975	*****	-0.2843	-0.3463	-0.4145	-0.5213	*****	*****	*****	*****	*****
1.000	0.0225	-0.1284	-0.1795	-0.3291	-0.2659	*****	*****	*****	*****	*****
-0.200	$C_{p,l}$	0.0670	0.0768	0.1372	*****	*****	*****	*****	*****	-0.5517
-0.400	0.0512	0.0828	0.1046	-0.0470	-0.6705	*****	*****	*****	*****	*****
-0.600	0.0525	0.0737	0.0907	-0.0182	-0.7202	*****	*****	*****	*****	*****
-0.700	0.0685	0.0591	0.0847	-0.0071	-0.7233	*****	*****	*****	*****	*****
-0.800	0.0997	*****	0.0655	0.0057	-0.6696	*****	*****	*****	*****	*****
-0.850	*****	0.0826	0.0669	0.0036	-0.6828	*****	*****	*****	*****	*****
-0.900	*****	0.1158	0.0847	0.0144	-0.7015	*****	*****	*****	*****	*****
-0.950	0.2029	0.1707	0.1437	0.0708	-0.2707	*****	*****	*****	*****	*****
-0.975	*****	0.2094	0.1880	0.1286	-0.0965	*****	*****	*****	*****	*****
-1.000	0.0004	-0.1090	-0.2949	-0.2736	-0.2044	*****	*****	*****	*****	*****

Medium Radius L.E.
 Run No. = 34 , Point No. = 673
 $C_N = 0.150$, $C_m = -0.0226$
 $\alpha = 3.9^\circ$, $M_\infty = 0.831$
 $R_{mac} = 120.3 \times 10^6$

Leading Edge Pressures

● starboard
 ○ port

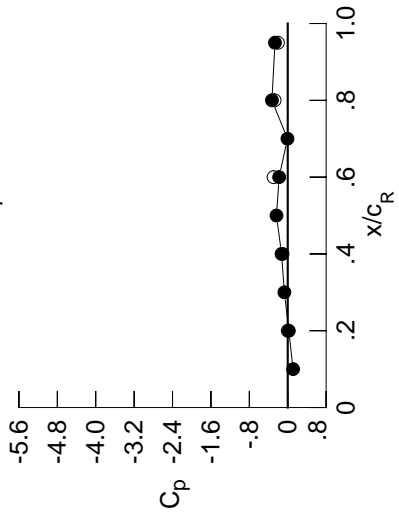

x/c_R	starb'd C_p	port C_p
0.10	0.1108	*****
0.20	0.0225	0.0004
0.30	-0.0694	*****
0.40	-0.1284	-0.1090
0.50	-0.2342	*****
0.60	-0.1795	-0.2949
0.70	-0.0055	*****
0.80	-0.3291	-0.2736
0.90	*****	*****
0.95	-0.2659	-0.2044

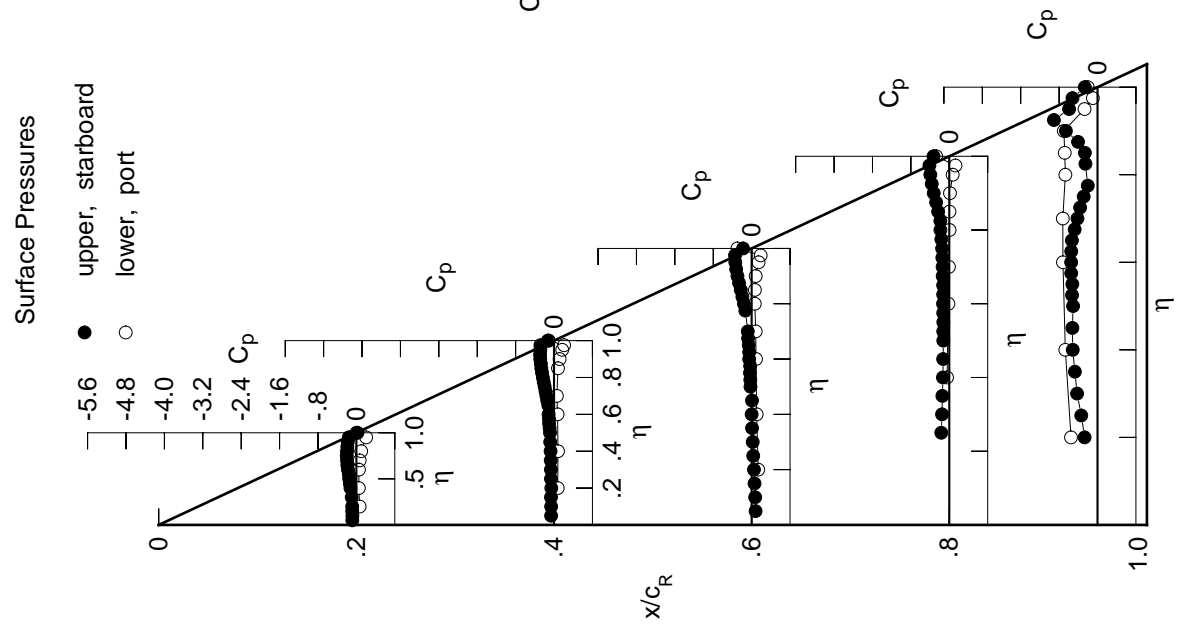

Table H2. Continued.

η	$x/c_R = .2$		$x/c_R = .4$		$x/c_R = .6$		$x/c_R = .8$		$x/c_R = .95$	
	$C_{p,u}$	$C_{p,l}$	$C_{p,u}$	$C_{p,l}$	$C_{p,u}$	$C_{p,l}$	$C_{p,u}$	$C_{p,l}$	$C_{p,u}$	$C_{p,l}$
0.050	-0.1061	-0.0780	0.0690	0.0690	0.0690	0.0690	0.0690	0.0690	0.0690	0.0690
0.100	-0.1043	-0.0783	0.0605	0.0605	0.0605	0.0605	0.0605	0.0605	0.0605	0.0605
0.150	-0.1081	-0.0804	0.0468	0.0468	0.0468	0.0468	0.0468	0.0468	0.0468	0.0468
0.200	-0.1098	-0.0759	0.0345	0.0345	0.0345	0.0345	0.0345	0.0345	0.0345	0.0345
0.250	0.0000	-0.0834	0.0185	-0.1792	0.0185	-0.1792	0.0185	-0.1792	0.0185	-0.3385
0.300	-0.1200	-0.0847	0.0074	-0.1636	0.0074	-0.1636	0.0074	-0.1636	0.0074	-0.4017
0.350	0.0000	-0.0903	-0.0061	-0.1565	-0.0061	-0.1565	-0.0061	-0.1565	-0.0061	-0.4428
0.400	-0.1495	-0.0933	-0.0165	-0.1461	-0.0165	-0.1461	-0.0165	-0.1461	-0.0165	-0.5095
0.450	-0.1635	-0.1025	-0.0103	-0.1424	-0.0103	-0.1424	-0.0103	-0.1424	-0.0103	-0.5555
0.500	-0.1800	-0.1080	-0.0425	-0.1402	-0.0425	-0.1402	-0.0425	-0.1402	-0.0425	-0.5792
0.525	0.0000	-0.1162	-0.0469	-0.1425	-0.0469	-0.1425	-0.0469	-0.1425	-0.0469	-0.6128
0.550	-0.1894	-0.1284	-0.0542	-0.1409	-0.0542	-0.1409	-0.0542	-0.1409	-0.0542	-0.6102
0.575	0.0000	-0.1330	-0.0515	-0.1439	-0.0515	-0.1439	-0.0515	-0.1439	-0.0515	-0.6220
0.600	-0.2110	-0.1420	-0.0718	-0.1478	-0.0718	-0.1478	-0.0718	-0.1478	-0.0718	-0.6021
0.625	0.0000	0.0000	-0.0738	-0.1470	-0.0738	-0.1470	-0.0738	-0.1470	-0.0738	-0.5653
0.650	-0.2263	-0.1506	-0.0847	-0.1498	-0.0847	-0.1498	-0.0847	-0.1498	-0.0847	-0.5162
0.675	0.0000	-0.1737	-0.0986	-0.1593	-0.0986	-0.1593	-0.0986	-0.1593	-0.0986	-0.4492
0.700	-0.2374	-0.1945	-0.1079	-0.1637	-0.1079	-0.1637	-0.1079	-0.1637	-0.1079	-0.3961
0.725	0.0000	-0.2160	0.0000	-0.1698	-0.1698	-0.1698	-0.1698	-0.1698	-0.1698	-0.3417
0.750	-0.2489	-0.2381	0.0000	-0.1777	-0.1777	-0.1777	-0.1777	-0.1777	-0.1777	-0.2634
0.775	0.0000	-0.2612	-0.1655	-0.1964	-0.1655	-0.1964	-0.1655	-0.1964	-0.1655	-0.1823
0.800	-0.2488	-0.2863	-0.1994	-0.2187	-0.1994	-0.2187	-0.1994	-0.2187	-0.1994	0.0000
0.825	0.0000	-0.3074	-0.2373	-0.2203	-0.2373	-0.2203	-0.2373	-0.2203	-0.2373	-0.2335
0.850	-0.2488	-0.3293	-0.2797	-0.2757	-0.2797	-0.2757	-0.2797	-0.2757	-0.2797	-0.2468
0.875	0.0000	-0.3455	-0.3250	-0.3254	-0.3250	-0.3254	-0.3250	-0.3254	-0.3250	-0.3722
0.900	-0.2501	-0.3677	-0.3709	-0.3889	-0.3709	-0.3889	-0.3709	-0.3889	-0.3709	-0.6670
0.925	0.0000	-0.3835	-0.4123	-0.4452	-0.4123	-0.4452	-0.4123	-0.4452	-0.4123	-0.8551
0.950	-0.2418	-0.3909	-0.4522	-0.4998	-0.4522	-0.4998	-0.4522	-0.4998	-0.4522	-0.6524
0.975	0.0000	-0.4189	-0.4852	-0.5598	-0.4852	-0.5598	-0.4852	-0.5598	-0.4852	-0.6269
1.000	-0.1123	-0.3529	-0.4049	-0.6526	-0.4049	-0.6526	-0.4049	-0.6526	-0.4049	-0.5109
-0.200	0.0894	0.0951	0.1507	0.1507	0.1507	0.1507	0.1507	0.1507	0.1507	-0.5488
-0.400	0.0747	0.1026	0.1196	0.1196	0.1196	0.1196	0.1196	0.1196	0.1196	-0.7381
-0.600	0.0801	0.0974	0.1076	0.1076	0.1076	0.1076	0.1076	0.1076	0.1076	-0.7386
-0.700	0.0994	0.0858	0.1047	0.1096	0.1047	0.1096	0.1047	0.1096	0.1047	-0.7173
-0.800	0.1315	0.0000	0.0916	0.0255	0.0916	0.0255	0.0916	0.0255	0.0916	-0.6569
-0.850	0.0000	0.1170	0.0963	0.0289	0.0963	0.0289	0.0963	0.0289	0.0963	-0.6653
-0.900	0.0000	0.1497	0.1184	0.0454	0.1184	0.0454	0.1184	0.0454	0.1184	-0.6708
-0.950	0.2230	0.1965	0.1718	0.1019	0.1718	0.1019	0.1718	0.1019	0.1718	-0.2510
-0.975	0.0000	0.2192	0.2014	0.1479	0.2014	0.1479	0.2014	0.1479	0.2014	-0.0766
-1.000	-0.1266	-0.3141	-0.6011	-0.5808	-0.6011	-0.5808	-0.6011	-0.5808	-0.6011	-0.4079

Medium Radius L.E.
 Run No. = 34 , Point No. = 674
 $C_N = 0.193$, $C_m = -0.0295$
 $\alpha = 4.9^\circ$, $M_\infty = 0.831$
 $R_{mac} = 120.1 \times 10^6$

Leading Edge Pressures

● starboard
 ○ port

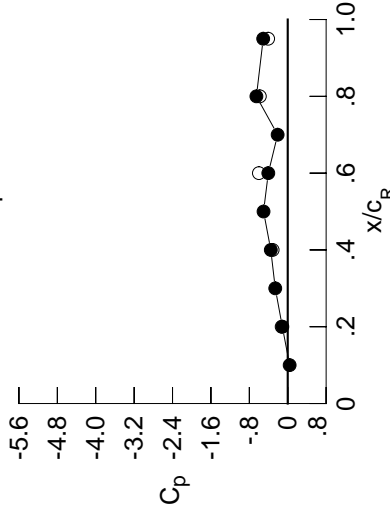

x/c_R	starb'd C_p	port C_p
0.10	0.0397	0.0397
0.20	-0.1123	-0.1123
0.30	-0.2596	-0.2596
0.40	-0.3529	-0.3529
0.50	-0.5039	-0.5039
0.60	-0.4049	-0.4049
0.70	-0.2103	-0.2103
0.80	-0.6526	-0.6526
0.90	0.0000	0.0000
0.95	-0.5109	-0.5109

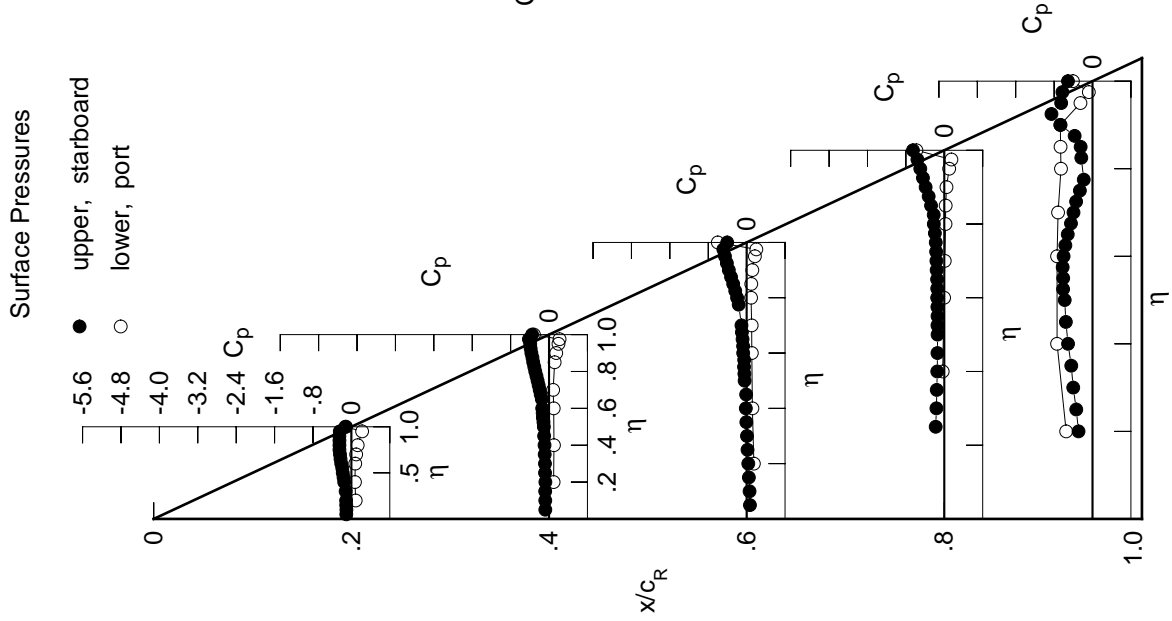
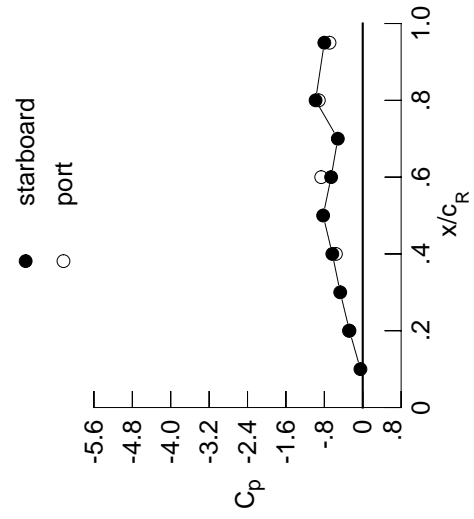

Table H2. Continued.

η	$x/c_R = .2$		$x/c_R = .4$		$x/c_R = .6$		$x/c_R = .8$		$x/c_R = .95$	
	$C_{p,u}$	$C_{p,u}$	$C_{p,u}$	$C_{p,u}$	$C_{p,u}$	$C_{p,u}$	$C_{p,u}$	$C_{p,u}$	$C_{p,u}$	$C_{p,u}$
0.050	-0.1248	-0.0948	0.0574	*****	*****	*****	*****	*****	*****	
0.100	-0.1240	-0.0951	0.0484	*****	*****	*****	*****	*****	*****	
0.150	-0.1288	-0.0978	0.0344	*****	*****	*****	*****	*****	*****	
0.200	-0.1302	-0.0932	0.0218	*****	*****	*****	*****	*****	-0.2992	
0.250	*****	-0.1015	0.0052	-0.1889	-0.3276	*****	*****	*****	*****	
0.300	-0.1423	-0.1035	-0.0059	-0.1742	-0.3708	*****	*****	*****	*****	
0.350	*****	-0.1092	-0.0203	-0.1668	-0.3933	*****	*****	*****	*****	
0.400	-0.1739	-0.1136	-0.0313	-0.1568	-0.4512	*****	*****	*****	*****	
0.450	-0.1895	-0.1241	-0.0264	-0.1541	-0.5180	*****	*****	*****	*****	
0.500	-0.2082	-0.1303	-0.0594	-0.1524	-0.5738	*****	*****	*****	*****	
0.525	*****	-0.1399	-0.0647	-0.1553	-0.6091	*****	*****	*****	*****	
0.550	-0.2206	-0.1533	-0.0729	-0.1545	-0.6013	*****	*****	*****	*****	
0.575	*****	-0.1589	-0.0710	-0.1580	-0.6025	*****	*****	*****	*****	
0.600	-0.2452	-0.1694	-0.0926	-0.1632	-0.5721	*****	*****	*****	*****	
0.625	*****	*****	-0.0957	-0.1632	-0.5327	*****	*****	*****	*****	
0.650	-0.2649	-0.1817	-0.1076	-0.1676	-0.4921	*****	*****	*****	*****	
0.675	*****	-0.2064	-0.1232	-0.1789	-0.4409	*****	*****	*****	*****	
0.700	-0.2809	-0.2301	-0.1342	-0.1847	-0.3934	*****	*****	*****	*****	
0.725	*****	-0.2546	*****	-0.1943	-0.3357	*****	*****	*****	*****	
0.750	-0.2976	-0.2800	*****	-0.2063	-0.2533	*****	*****	*****	*****	
0.775	*****	-0.3080	-0.2021	-0.2288	-0.1756	*****	*****	*****	*****	
0.800	-0.3046	-0.3386	-0.2401	-0.2529	*****	*****	*****	*****	*****	
0.825	*****	-0.3668	-0.2832	-0.2588	-0.2142	*****	*****	*****	*****	
0.850	-0.3130	-0.3958	-0.3332	-0.3167	-0.2398	*****	*****	*****	*****	
0.875	*****	-0.4224	-0.3889	-0.3747	-0.3314	*****	*****	*****	*****	
0.900	-0.3258	-0.4547	-0.4525	-0.4496	-0.6533	*****	*****	*****	*****	
0.925	*****	-0.4816	-0.5180	-0.5248	-0.9134	*****	*****	*****	*****	
0.950	-0.3358	-0.5059	-0.5796	-0.6043	-0.7232	*****	*****	*****	*****	
0.975	*****	-0.5786	-0.6578	-0.7014	-0.7431	*****	*****	*****	*****	
1.000	-0.2760	-0.6333	-0.6587	-0.9825	-0.8003	*****	*****	*****	*****	
-0.200	$C_{p,l}$	$C_{p,l}$	$C_{p,l}$	$C_{p,l}$	$C_{p,l}$	$C_{p,l}$	$C_{p,l}$	$C_{p,l}$	$C_{p,l}$	
-0.400	0.1131	0.1149	0.1661	*****	-0.5364	*****	*****	*****	*****	
-0.600	0.1009	0.1235	0.1361	-0.0201	-0.7500	*****	*****	*****	*****	
-0.700	0.1100	0.1211	0.1259	0.0112	-0.7361	*****	*****	*****	*****	
-0.800	0.1311	0.1132	0.1263	0.0264	-0.7089	*****	*****	*****	*****	
-0.850	0.1629	*****	0.1174	0.0461	-0.6446	*****	*****	*****	*****	
-0.900	*****	0.1493	0.1253	0.0526	-0.6501	*****	*****	*****	*****	
-0.950	0.2373	0.2156	0.1937	0.1265	-0.2363	*****	*****	*****	*****	
-0.975	*****	0.2177	0.2045	0.1571	-0.0667	*****	*****	*****	*****	
-1.000	-0.2866	-0.5596	-0.8647	-0.9141	-0.6918	*****	*****	*****	*****	

Medium Radius L.E.
 Run No. = 34 , Point No. = 675
 $C_N = 0.238$, $C_m = -0.0364$
 $\alpha = 6.1^\circ$, $M_\infty = 0.830$
 $R_{mac} = 119.9 \times 10^6$

Leading Edge Pressures



x/c_R	starb'd C_p	port C_p
0.10	-0.0484	*****
0.20	-0.2760	-0.2866
0.30	-0.4688	*****
0.40	-0.6333	-0.5596
0.50	-0.8246	*****
0.60	-0.6587	-0.8647
0.70	-0.5188	*****
0.80	-0.9825	-0.9141
0.90	*****	*****
0.95	-0.8003	-0.6918

Surface Pressures

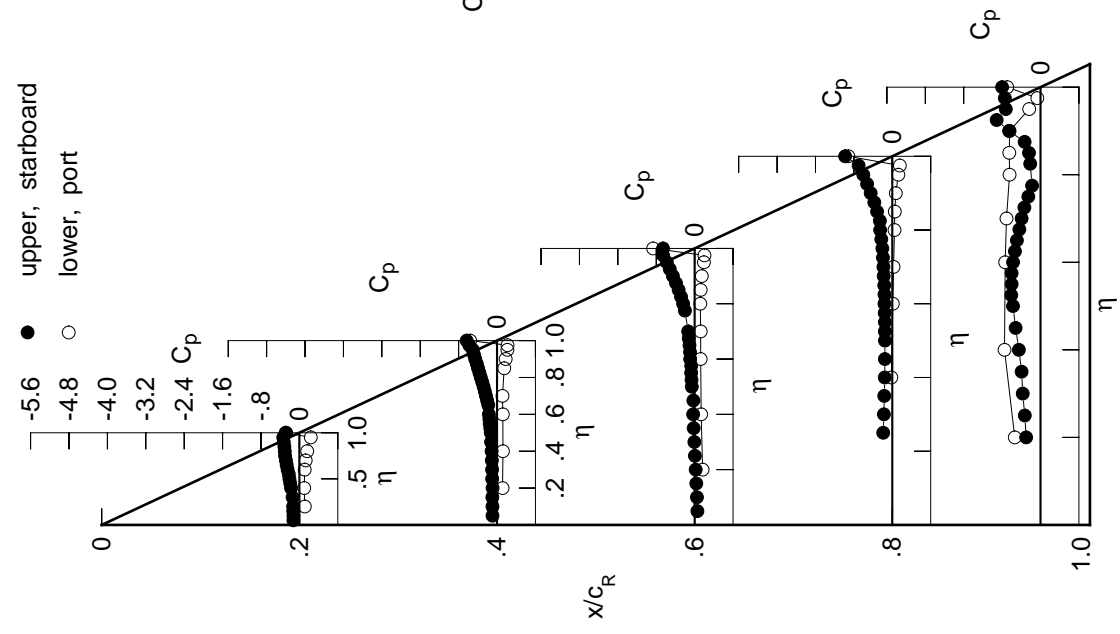
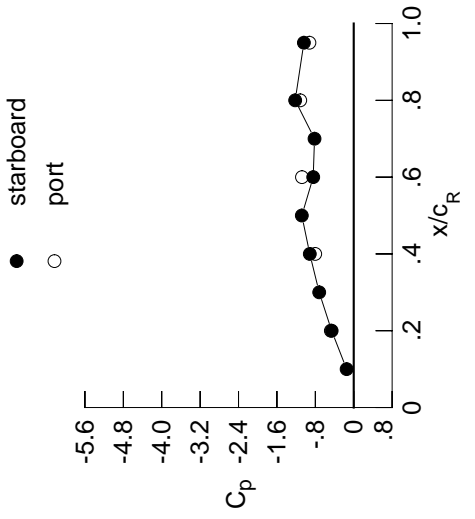

Table H2. Continued.

η	$x/c_R = .2$		$x/c_R = .4$		$x/c_R = .6$		$x/c_R = .8$		$x/c_R = .95$	
	$C_{p,u}$	$C_{p,l}$	$C_{p,u}$	$C_{p,l}$	$C_{p,u}$	$C_{p,l}$	$C_{p,u}$	$C_{p,l}$	$C_{p,u}$	$C_{p,l}$
0.050	-0.1418	-0.1116	0.0465	*****	*****	*****	*****	*****	*****	*****
0.100	-0.1427	-0.1126	0.0370	*****	*****	*****	*****	*****	*****	*****
0.150	-0.1483	-0.1157	0.0229	*****	*****	*****	*****	*****	*****	*****
0.200	-0.1505	-0.1118	0.0100	*****	*****	*****	*****	*****	*****	-0.2997
0.250	*****	-0.1196	-0.0068	-0.2005	-0.3158	*****	*****	*****	*****	-0.3158
0.300	-0.1626	-0.1226	-0.0189	-0.1858	-0.3548	*****	*****	*****	*****	-0.3548
0.350	*****	-0.1290	-0.0336	-0.1790	-0.3734	*****	*****	*****	*****	-0.3734
0.400	-0.1967	-0.1344	-0.0459	-0.1696	-0.4286	*****	*****	*****	*****	-0.4286
0.450	-0.2148	-0.1463	-0.0415	-0.1668	-0.5195	*****	*****	*****	*****	-0.5195
0.500	-0.2362	-0.1540	-0.0764	-0.1655	-0.6321	*****	*****	*****	*****	-0.6321
0.525	*****	-0.1642	-0.0826	-0.1682	-0.6802	*****	*****	*****	*****	-0.6802
0.550	-0.2511	-0.1785	-0.0909	-0.1673	-0.6764	*****	*****	*****	*****	-0.6764
0.575	*****	-0.1858	-0.0898	-0.1732	-0.6801	*****	*****	*****	*****	-0.6801
0.600	-0.2791	-0.1975	-0.1142	-0.1813	-0.6472	*****	*****	*****	*****	-0.6472
0.625	*****	*****	-0.1195	-0.1857	-0.6060	*****	*****	*****	*****	-0.6060
0.650	-0.3033	-0.2124	-0.1348	-0.1935	-0.5648	*****	*****	*****	*****	-0.5648
0.675	*****	-0.2389	-0.1532	-0.2095	-0.5171	*****	*****	*****	*****	-0.5171
0.700	-0.3239	-0.2646	-0.1687	-0.2229	-0.4833	*****	*****	*****	*****	-0.4833
0.725	*****	-0.2925	*****	-0.2397	-0.4444	*****	*****	*****	*****	-0.4444
0.750	-0.3471	-0.3225	*****	-0.2538	-0.3807	*****	*****	*****	*****	-0.3807
0.775	*****	-0.3557	-0.2420	-0.2785	-0.3005	*****	*****	*****	*****	-0.3005
0.800	-0.3607	-0.3916	-0.2788	-0.3016	*****	*****	*****	*****	*****	-0.3016
0.825	*****	-0.4265	-0.3250	-0.3097	-0.2521	*****	*****	*****	*****	-0.2521
0.850	-0.3782	-0.4624	-0.3802	-0.3620	-0.2560	*****	*****	*****	*****	-0.2560
0.875	*****	-0.4985	-0.4451	-0.3995	-0.2938	*****	*****	*****	*****	-0.2938
0.900	-0.4035	-0.5421	-0.5133	-0.4797	-0.4077	*****	*****	*****	*****	-0.4077
0.925	*****	-0.5886	-0.5839	-0.5720	-0.6452	*****	*****	*****	*****	-0.6452
0.950	-0.4332	-0.6320	-0.6607	-0.6774	-0.7812	*****	*****	*****	*****	-0.7812
0.975	*****	-0.7390	-0.8366	-0.8828	-0.8112	*****	*****	*****	*****	-0.8112
1.000	-0.4601	-0.9155	-0.8441	-1.2198	-1.0382	*****	*****	*****	*****	-1.0382
-0.200	$C_{p,l}$	$C_{p,l}$	$C_{p,l}$	$C_{p,l}$	$C_{p,l}$	$C_{p,l}$	$C_{p,l}$	$C_{p,l}$	$C_{p,l}$	$C_{p,l}$
-0.400	0.1373	0.1358	0.1821	*****	-0.5408	*****	*****	*****	*****	-0.5408
-0.600	0.1271	0.1451	0.1531	-0.0051	-0.7388	*****	*****	*****	*****	-0.7388
-0.700	0.1391	0.1449	0.1449	0.0268	-0.7233	*****	*****	*****	*****	-0.7233
-0.800	0.1610	0.1402	0.1468	0.0436	-0.6956	*****	*****	*****	*****	-0.6956
-0.850	0.1923	*****	0.1417	0.0658	-0.6278	*****	*****	*****	*****	-0.6278
-0.900	*****	0.1790	0.1515	0.0748	-0.6322	*****	*****	*****	*****	-0.6322
-0.950	*****	0.2069	0.1744	0.0978	-0.6189	*****	*****	*****	*****	-0.6189
-0.975	0.2453	0.2288	0.2084	0.1447	-0.2267	*****	*****	*****	*****	-0.2267
-1.000	*****	0.2080	0.1995	0.1582	-0.0685	*****	*****	*****	*****	-0.0685
	-0.4764	-0.8022	-1.0783	-1.1142	-0.9233	*****	*****	*****	*****	-0.9233

Medium Radius L.E.
 Run No. = 34 , Point No. = 676
 $C_N = 0.283$, $C_m = -0.0433$
 $\alpha = 7.1^\circ$, $M_\infty = 0.830$
 $R_{mac} = 120.1 \times 10^6$

Leading Edge Pressures



x/c_R	starb'd C_p	port C_p
0.10	-0.1483	*****
0.20	-0.4601	-0.4764
0.30	-0.7193	*****
0.40	-0.9155	-0.8022
0.50	-1.0814	*****
0.60	-0.8441	-1.0783
0.70	-0.8170	*****
0.80	-1.2198	-1.1142
0.90	*****	*****
0.95	-1.0382	-0.9233

Surface Pressures

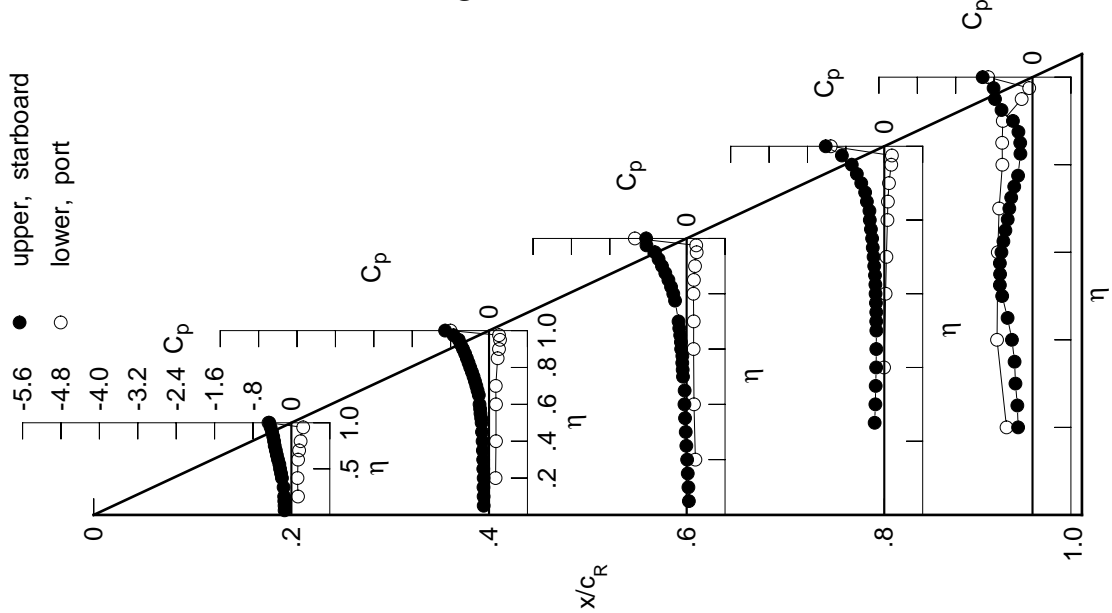

Table H2. Continued.

η	$x/c_R = .2$		$x/c_R = .4$		$x/c_R = .6$		$x/c_R = .8$		$x/c_R = .95$	
	$C_{p,u}$	$C_{p,u}$	$C_{p,u}$	$C_{p,u}$	$C_{p,u}$	$C_{p,u}$	$C_{p,u}$	$C_{p,u}$	$C_{p,u}$	$C_{p,u}$
0.050	-0.1595	-0.1311	0.0295	*****	*****	*****	*****	*****	*****	*****
0.100	-0.1629	-0.1327	0.0203	*****	*****	*****	*****	*****	*****	*****
0.150	-0.1693	-0.1356	0.0050	*****	*****	*****	*****	*****	*****	*****
0.200	-0.1717	-0.1331	-0.0077	*****	*****	*****	*****	*****	*****	-0.3054
0.250	*****	-0.1410	-0.0264	-0.2253	-0.3038	*****	*****	*****	*****	-0.3038
0.300	-0.1856	-0.1451	-0.0378	-0.2102	-0.3447	*****	*****	*****	*****	-0.3447
0.350	*****	-0.1522	-0.0525	-0.2024	-0.3792	*****	*****	*****	*****	-0.3792
0.400	-0.2219	-0.1586	-0.0670	-0.1915	-0.4548	*****	*****	*****	*****	-0.4548
0.450	-0.2411	-0.1710	-0.0600	-0.1914	-0.4800	*****	*****	*****	*****	-0.4800
0.500	-0.2645	-0.1810	-0.1034	-0.1939	-0.4362	*****	*****	*****	*****	-0.4362
0.525	*****	-0.1942	-0.1131	-0.1996	-0.4154	*****	*****	*****	*****	-0.4154
0.550	-0.2834	-0.2112	-0.1256	-0.2073	-0.3604	*****	*****	*****	*****	-0.3604
0.575	*****	-0.2208	-0.1282	-0.2212	-0.3380	*****	*****	*****	*****	-0.3380
0.600	-0.3144	-0.2337	-0.1569	-0.2339	-0.3446	*****	*****	*****	*****	-0.3446
0.625	*****	*****	-0.1640	-0.2306	-0.3808	*****	*****	*****	*****	-0.3808
0.650	-0.3435	-0.2538	-0.1841	-0.2242	-0.4255	*****	*****	*****	*****	-0.4255
0.675	*****	-0.2798	-0.2043	-0.2243	-0.4427	*****	*****	*****	*****	-0.4427
0.700	-0.3697	-0.3066	-0.2172	-0.2204	-0.4553	*****	*****	*****	*****	-0.4553
0.725	*****	-0.3351	*****	-0.2207	-0.4998	*****	*****	*****	*****	-0.4998
0.750	-0.4000	-0.3678	*****	-0.2368	-0.5598	*****	*****	*****	*****	-0.5598
0.775	*****	-0.4040	-0.2811	-0.3245	-0.6250	*****	*****	*****	*****	-0.6250
0.800	-0.4231	-0.4445	-0.3135	-0.4320	*****	*****	*****	*****	*****	-0.4320
0.825	*****	-0.4862	-0.3506	-0.5229	-0.6587	*****	*****	*****	*****	-0.6587
0.850	-0.4499	-0.5305	-0.3940	-0.6412	-0.6342	*****	*****	*****	*****	-0.6342
0.875	*****	-0.5748	-0.5045	-0.6420	-0.6581	*****	*****	*****	*****	-0.6581
0.900	-0.4907	-0.6291	-0.7252	-0.6777	-0.6784	*****	*****	*****	*****	-0.6784
0.925	*****	-0.6846	-0.9255	-0.7807	-0.6272	*****	*****	*****	*****	-0.6272
0.950	-0.5514	-0.7313	-1.0337	-0.8028	-0.5212	*****	*****	*****	*****	-0.5212
0.975	*****	-1.0619	-1.0547	-0.7709	-0.7268	*****	*****	*****	*****	-0.7268
1.000	-0.6833	-1.1361	-0.9304	-1.2644	-1.1213	*****	*****	*****	*****	-1.1213
-0.200	$C_{p,l}$	$C_{p,l}$	$C_{p,l}$	$C_{p,l}$	$C_{p,l}$	$C_{p,l}$	$C_{p,l}$	$C_{p,l}$	$C_{p,l}$	$C_{p,l}$
-0.400	0.1636	0.1600	0.2004	*****	*****	*****	*****	*****	*****	-0.5634
-0.600	0.1546	0.1697	0.1729	0.0122	-0.7265	*****	*****	*****	*****	-0.7265
-0.700	0.1692	0.1716	0.1663	0.0454	-0.7079	*****	*****	*****	*****	-0.7079
-0.800	0.1915	0.1686	0.1707	0.0632	-0.6783	*****	*****	*****	*****	-0.6783
-0.850	0.2215	*****	0.1671	0.0872	-0.6077	*****	*****	*****	*****	-0.6077
-0.900	*****	0.2075	0.1781	0.0981	-0.6091	*****	*****	*****	*****	-0.6091
-0.950	*****	0.2310	0.1995	0.1219	-0.5897	*****	*****	*****	*****	-0.5897
-0.975	0.2483	0.2376	0.2214	0.1616	-0.2128	*****	*****	*****	*****	-0.2128
-1.000	*****	0.1936	0.1946	0.1623	-0.0631	*****	*****	*****	*****	-0.0631
-1.000	-0.7099	-1.0135	-1.2028	-1.1617	-0.9653	*****	*****	*****	*****	-0.9653

Medium Radius L.E.
 Run No. = 34, Point No. = 677
 $C_N = 0.348$, $C_m = -0.0584$
 $\alpha = 8.2^\circ$, $M_\infty = 0.831$
 $R_{mac} = 120.0 \times 10^6$

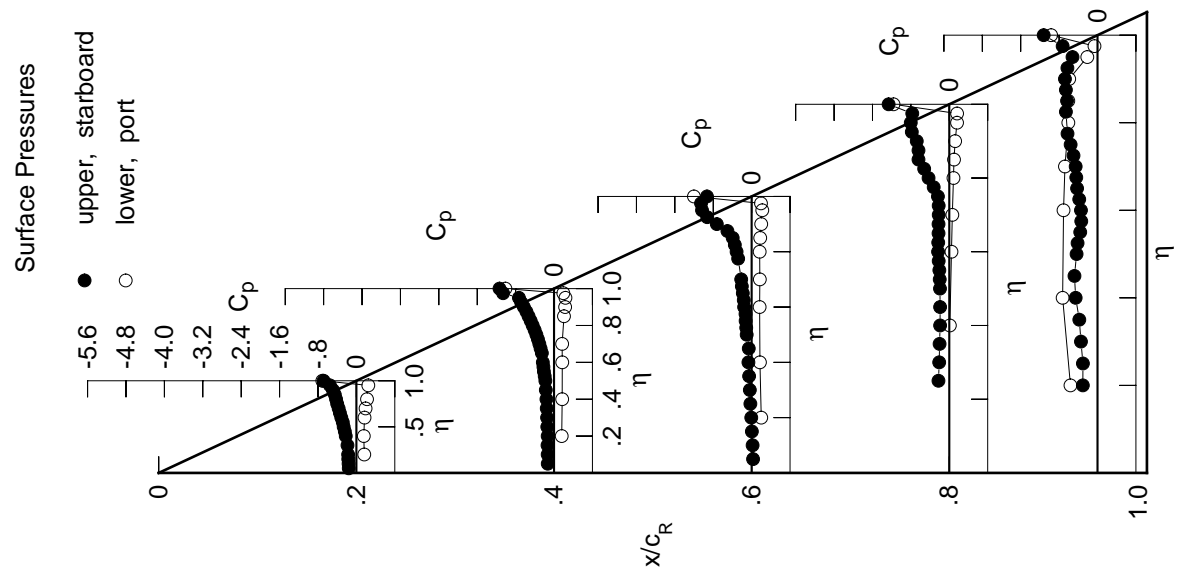
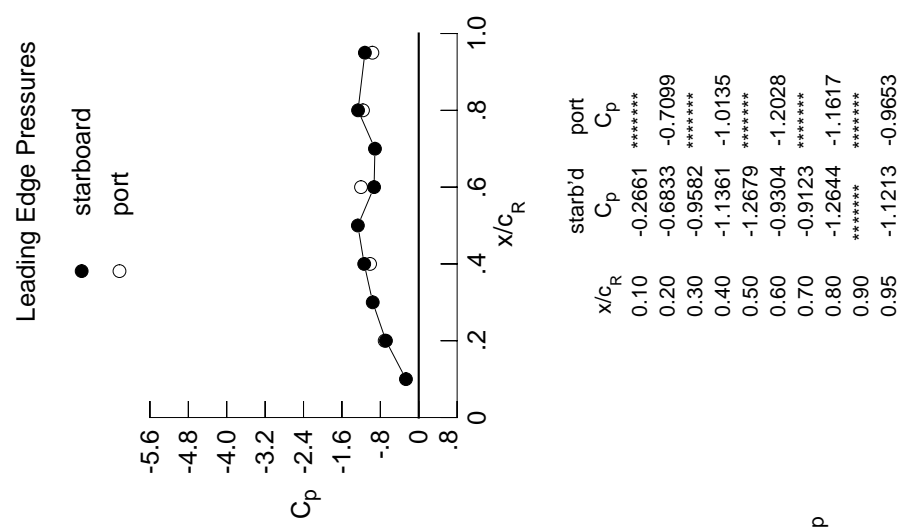
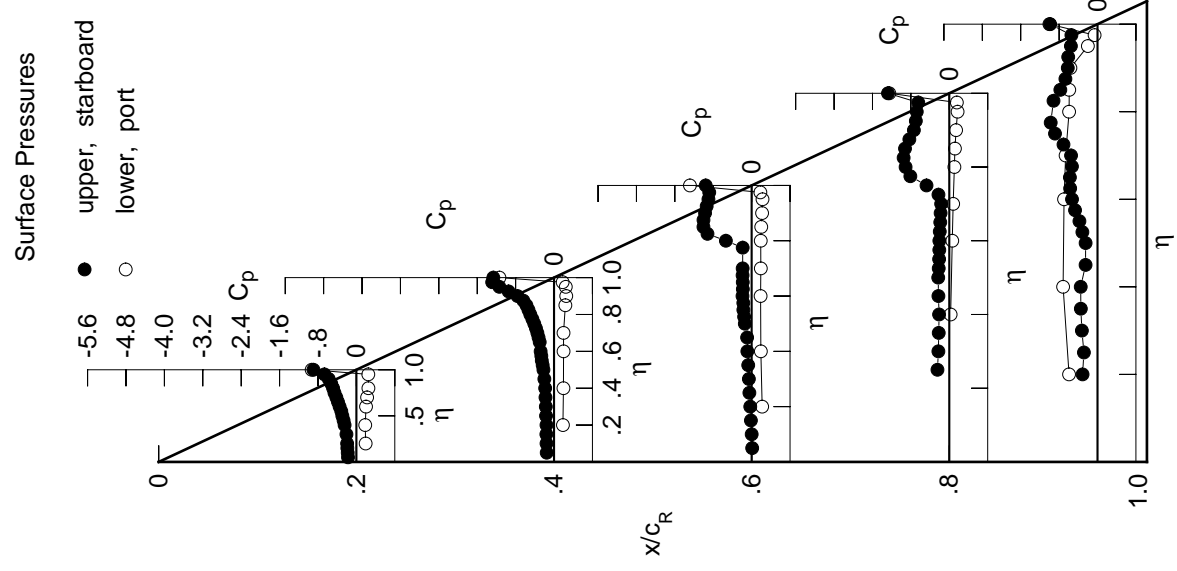
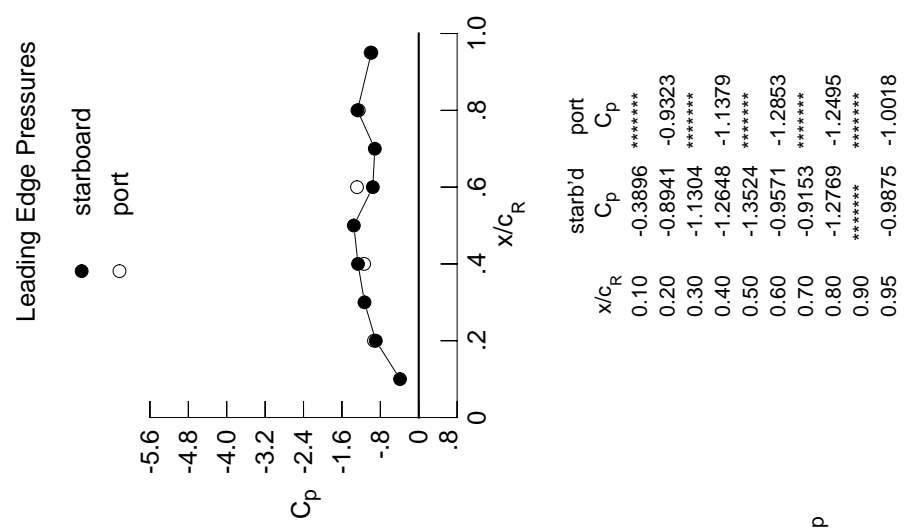

Table H2. Continued.

η	$x/c_R = .2$		$x/c_R = .4$		$x/c_R = .6$		$x/c_R = .8$		$x/c_R = .95$	
	$C_{p,u}$	$C_{p,u}$	$C_{p,u}$	$C_{p,u}$	$C_{p,u}$	$C_{p,u}$	$C_{p,u}$	$C_{p,u}$	$C_{p,u}$	$C_{p,u}$
0.050	-0.1746	-0.1530	0.0111	*****	*****	*****	*****	*****	*****	
0.100	-0.1810	-0.1569	0.0005	*****	*****	*****	*****	*****	*****	
0.150	-0.1884	-0.1598	-0.0152	*****	*****	*****	*****	*****	*****	
0.200	-0.1925	-0.1579	-0.0286	*****	*****	*****	*****	*****	-0.3113	
0.250	*****	-0.1664	-0.0468	-0.2463	-0.2832	*****	*****	*****	*****	
0.300	-0.2074	-0.1711	-0.0575	-0.2273	-0.3256	*****	*****	*****	*****	
0.350	*****	-0.1784	-0.0716	-0.2200	-0.3475	*****	*****	*****	*****	
0.400	-0.2456	-0.1850	-0.0899	-0.2124	-0.3500	*****	*****	*****	*****	
0.450	-0.2668	-0.2014	-0.0942	-0.2262	-0.2489	*****	*****	*****	*****	
0.500	-0.2926	-0.2209	-0.1422	-0.2301	-0.2478	*****	*****	*****	*****	
0.525	*****	-0.2371	-0.1569	-0.2204	-0.3153	*****	*****	*****	*****	
0.550	-0.3148	-0.2548	-0.1730	-0.2119	-0.3767	*****	*****	*****	*****	
0.575	*****	-0.2649	-0.1738	-0.2081	-0.4682	*****	*****	*****	*****	
0.600	-0.3494	-0.2791	-0.1906	-0.2075	-0.5316	*****	*****	*****	*****	
0.625	*****	*****	-0.1829	-0.1984	-0.5696	*****	*****	*****	*****	
0.650	-0.3836	-0.2984	-0.1851	-0.1876	-0.5748	*****	*****	*****	*****	
0.675	*****	-0.3222	-0.1890	-0.1805	-0.5332	*****	*****	*****	*****	
0.700	-0.4173	-0.3476	-0.1871	-0.1693	-0.5509	*****	*****	*****	*****	
0.725	*****	-0.3771	*****	-0.2256	-0.7087	*****	*****	*****	*****	
0.750	-0.4565	-0.4118	*****	-0.4743	-0.8858	*****	*****	*****	*****	
0.775	*****	-0.4509	-0.1861	-0.8112	-0.9753	*****	*****	*****	*****	
0.800	-0.4860	-0.4946	-0.5365	-0.9107	*****	*****	*****	*****	*****	
0.825	*****	-0.5332	-0.9198	-0.9512	-0.9167	*****	*****	*****	*****	
0.850	-0.5238	-0.5750	-1.0038	-0.9224	-0.7743	*****	*****	*****	*****	
0.875	*****	-0.6393	-1.0036	-0.8322	-0.6690	*****	*****	*****	*****	
0.900	-0.5772	-0.7618	-0.9706	-0.7376	-0.6190	*****	*****	*****	*****	
0.925	*****	-0.9462	-0.9365	-0.6971	-0.6107	*****	*****	*****	*****	
0.950	-0.6666	-1.1392	-0.8997	-0.6772	-0.5540	*****	*****	*****	*****	
0.975	*****	-1.2885	-0.8835	-0.6464	-0.5438	*****	*****	*****	*****	
1.000	-0.8941	-1.2648	-0.9571	-1.2769	-0.9875	*****	*****	*****	*****	
-0.200	$C_{p,l}$	$C_{p,l}$	$C_{p,l}$	$C_{p,l}$	$C_{p,l}$	$C_{p,l}$	$C_{p,l}$	$C_{p,l}$	$C_{p,l}$	
-0.400	0.1925	0.1853	0.2194	*****	*****	-0.5928	*****	*****	*****	
-0.600	0.1843	0.1958	0.1919	0.0283	-0.7168	*****	*****	*****	*****	
-0.700	0.2008	0.1985	0.1866	0.0618	-0.6971	*****	*****	*****	*****	
-0.800	0.2230	0.1976	0.1914	0.0807	-0.6646	*****	*****	*****	*****	
-0.850	0.2501	*****	0.1892	0.1061	-0.5918	*****	*****	*****	*****	
-0.900	*****	0.2362	0.2002	0.1177	-0.5892	*****	*****	*****	*****	
-0.950	*****	0.2541	0.2179	0.1417	-0.5646	*****	*****	*****	*****	
-0.975	0.2478	0.2452	0.2261	0.1727	-0.2007	*****	*****	*****	*****	
-1.000	0.2478	0.1790	0.1814	0.1579	-0.0606	*****	*****	*****	*****	
	-0.9323	-1.1379	-1.2853	-1.2495	-1.0018	*****	*****	*****	*****	

Medium Radius L.E.
 Run No. = 34 , Point No. = 678
 $C_N = 0.408$, $C_m = -0.0686$
 $\alpha = 9.3^\circ$, $M_\infty = 0.830$
 $R_{mac} = 120.0 \times 10^6$



x/c_R	starb'd C_p	port C_p
0.10	-0.3896	*****
0.20	-0.8941	-0.9323
0.30	-1.1304	*****
0.40	-1.2648	-1.1379
0.50	-1.3524	*****
0.60	-0.9571	-1.2853
0.70	-0.9153	*****
0.80	-1.2769	-1.2495
0.90	*****	*****
0.95	-0.9875	-1.0018

Table H2. Continued.

η	$x/c_R = .2$		$x/c_R = .4$		$x/c_R = .6$		$x/c_R = .8$		$x/c_R = .95$	
	$C_{p,u}$	$C_{p,u}$	$C_{p,u}$	$C_{p,u}$	$C_{p,u}$	$C_{p,u}$	$C_{p,u}$	$C_{p,u}$	$C_{p,u}$	$C_{p,u}$
0.050	-0.1900	-0.1819	-0.0130	*****	*****	*****	*****	*****	*****	*****
0.100	-0.1990	-0.1859	-0.0247	*****	*****	*****	*****	*****	*****	*****
0.150	-0.2087	-0.1900	-0.0408	*****	*****	*****	*****	*****	*****	*****
0.200	-0.2142	-0.1888	-0.0547	*****	*****	*****	*****	*****	*****	-0.2753
0.250	*****	-0.1977	-0.0677	-0.2620	-0.2691	*****	*****	*****	*****	*****
0.300	-0.2303	-0.2001	-0.0820	-0.2430	-0.3263	*****	*****	*****	*****	*****
0.350	*****	-0.2089	-0.1047	-0.2450	-0.3117	*****	*****	*****	*****	*****
0.400	-0.2704	-0.2258	-0.1354	-0.2489	-0.2485	*****	*****	*****	*****	*****
0.450	-0.2934	-0.2515	-0.1457	-0.2273	-0.3222	*****	*****	*****	*****	*****
0.500	-0.3218	-0.2702	-0.1620	-0.2170	-0.4490	*****	*****	*****	*****	*****
0.525	*****	-0.2851	-0.1601	-0.2156	-0.5263	*****	*****	*****	*****	*****
0.550	-0.3476	-0.3017	-0.1611	-0.2093	-0.5604	*****	*****	*****	*****	*****
0.575	*****	-0.3044	-0.1531	-0.2046	-0.5995	*****	*****	*****	*****	*****
0.600	-0.3863	-0.3121	-0.1744	-0.2018	-0.5923	*****	*****	*****	*****	*****
0.625	*****	*****	-0.1686	-0.1934	-0.5836	*****	*****	*****	*****	*****
0.650	-0.4254	-0.3222	-0.1689	-0.2059	-0.6063	*****	*****	*****	*****	*****
0.675	*****	-0.3483	-0.1682	-0.2820	-0.6704	*****	*****	*****	*****	*****
0.700	-0.4631	-0.3686	-0.1720	-0.4609	-0.8129	*****	*****	*****	*****	*****
0.725	*****	-0.3847	*****	-0.7262	-0.9589	*****	*****	*****	*****	*****
0.750	-0.5065	-0.3960	*****	-0.9283	-1.0323	*****	*****	*****	*****	*****
0.775	*****	-0.4213	-1.0033	-1.0436	-1.0256	*****	*****	*****	*****	*****
0.800	-0.5467	-0.5859	-1.0906	-1.0251	*****	*****	*****	*****	*****	*****
0.825	*****	-0.8482	-1.0976	-1.0155	-0.6726	*****	*****	*****	*****	*****
0.850	-0.6015	-1.0220	-1.0651	-0.8981	-0.5964	*****	*****	*****	*****	*****
0.875	*****	-1.0917	-1.0158	-0.7646	-0.5771	*****	*****	*****	*****	*****
0.900	-0.6651	-1.1480	-0.9285	-0.7235	-0.5579	*****	*****	*****	*****	*****
0.925	*****	-1.1604	-0.8536	-0.6743	-0.5650	*****	*****	*****	*****	*****
0.950	-0.7829	-1.1635	-0.8080	-0.6637	-0.5228	*****	*****	*****	*****	*****
0.975	*****	-1.1448	-0.7846	-0.6203	-0.5090	*****	*****	*****	*****	*****
1.000	-1.0498	-1.3535	-0.9411	-1.2639	-0.7273	*****	*****	*****	*****	*****
-0.200	$C_{p,l}$	0.2230	0.2123	0.2386	*****	*****	*****	*****	*****	-0.6120
-0.400	$C_{p,l}$	0.2161	0.2232	0.2131	0.0434	-0.7126	*****	*****	*****	*****
-0.600	$C_{p,l}$	0.2337	0.2274	0.2091	0.0782	-0.6896	*****	*****	*****	*****
-0.700	$C_{p,l}$	0.2552	0.2275	0.2158	0.0971	-0.6560	*****	*****	*****	*****
-0.800	$C_{p,l}$	0.2787	*****	0.2143	0.1228	-0.5794	*****	*****	*****	*****
-0.850	$C_{p,l}$	*****	0.2633	0.2253	0.1349	-0.5736	*****	*****	*****	*****
-0.900	$C_{p,l}$	*****	0.2756	0.2414	0.1577	-0.5430	*****	*****	*****	*****
-0.950	$C_{p,l}$	0.2456	0.2521	0.2405	0.1815	-0.1833	*****	*****	*****	*****
-0.975	$C_{p,l}$	*****	0.1674	0.1848	0.1574	-0.0401	*****	*****	*****	*****
-1.000	$C_{p,l}$	-1.1129	-1.2028	-1.2712	-1.2197	-0.6422	*****	*****	*****	*****

Medium Radius L.E.
 Run No. = 34 , Point No. = 679
 $C_N = 0.469$, $C_m = -0.0766$
 $\alpha = 10.4^\circ$, $M_\infty = 0.829$
 $R_{mac} = 120.0 \times 10^6$

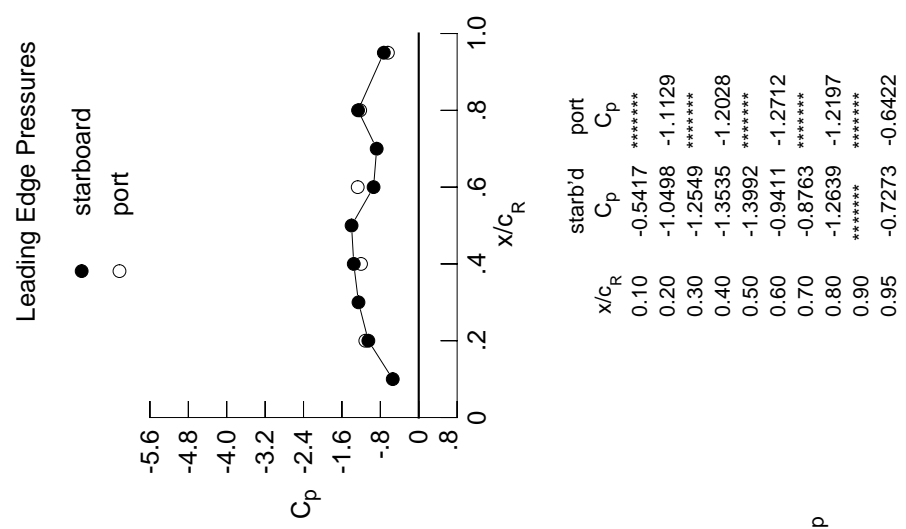

x/c_R	starb'd C_p	port C_p
0.10	-0.5417	*****
0.20	-1.0498	-1.1129
0.30	-1.2549	*****
0.40	-1.3535	-1.2028
0.50	-1.3992	*****
0.60	-0.9411	-1.2712
0.70	-0.8763	*****
0.80	-1.2639	-1.2197
0.90	*****	*****
0.95	-0.7273	-0.6422

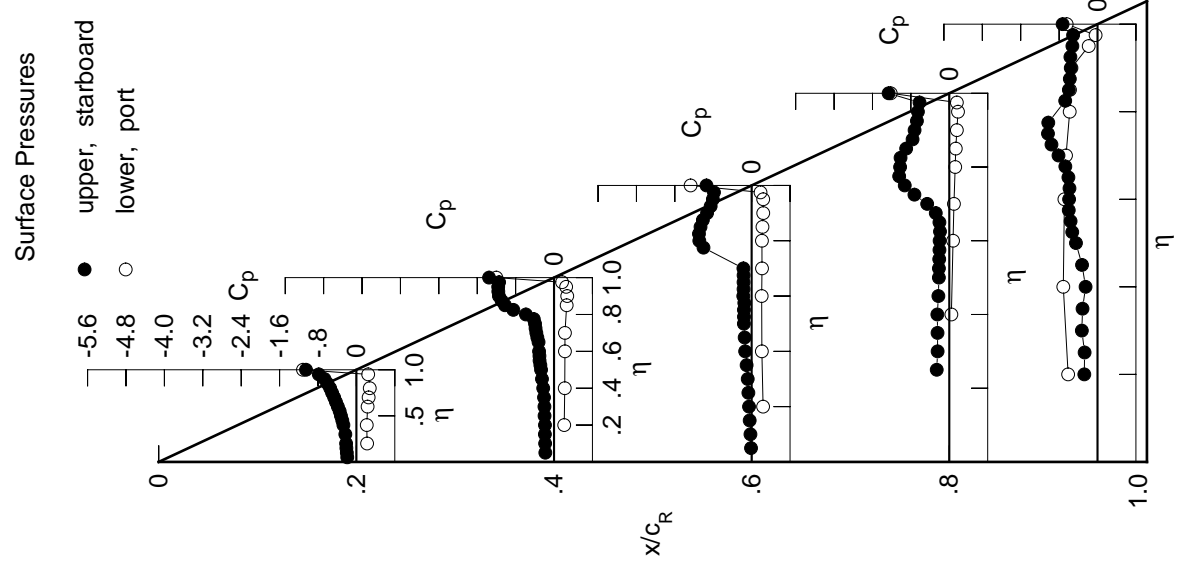
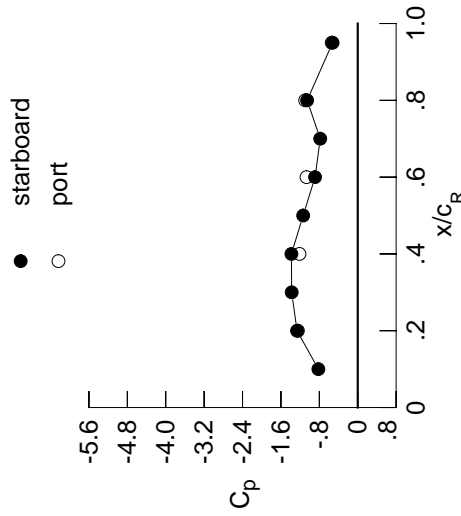

Table H2. Continued.

η	$x/c_R = .2$		$x/c_R = .4$		$x/c_R = .6$		$x/c_R = .8$		$x/c_R = .95$	
	$C_{p,u}$	$C_{p,u}$	$C_{p,u}$	$C_{p,u}$	$C_{p,u}$	$C_{p,u}$	$C_{p,u}$	$C_{p,u}$	$C_{p,u}$	$C_{p,u}$
0.050	-0.2359	-0.2532	-0.0590	*****	*****	*****	*****	*****	*****	*****
0.100	-0.2410	-0.2541	-0.0693	*****	*****	*****	*****	*****	*****	*****
0.150	-0.2602	-0.2590	-0.0861	*****	*****	*****	*****	*****	*****	*****
0.200	-0.2700	-0.2560	-0.0980	*****	*****	*****	*****	*****	*****	*****
0.250	*****	-0.2655	-0.1175	-0.2863	-0.3858	*****	*****	*****	*****	*****
0.300	-0.2960	-0.2793	-0.1451	-0.2787	-0.4236	*****	*****	*****	*****	*****
0.350	*****	-0.3058	-0.1823	-0.2778	-0.4080	*****	*****	*****	*****	*****
0.400	-0.3437	-0.3185	-0.1827	-0.2534	-0.4572	*****	*****	*****	*****	*****
0.450	-0.3646	-0.3567	-0.1631	-0.2400	-0.5392	*****	*****	*****	*****	*****
0.500	-0.3922	-0.3651	-0.1846	-0.2284	-0.5690	*****	*****	*****	*****	*****
0.525	*****	-0.3598	-0.1827	-0.2267	-0.5757	*****	*****	*****	*****	*****
0.550	-0.4198	-0.3672	-0.1820	-0.2273	-0.5515	*****	*****	*****	*****	*****
0.575	*****	-0.3620	-0.1648	-0.2415	-0.5631	*****	*****	*****	*****	*****
0.600	-0.4619	-0.3546	-0.1995	-0.2810	-0.5708	*****	*****	*****	*****	*****
0.625	*****	*****	-0.2284	-0.3598	-0.6304	*****	*****	*****	*****	*****
0.650	-0.5073	-0.3289	-0.3680	-0.5129	-0.7393	*****	*****	*****	*****	*****
0.675	*****	-0.3281	-0.6381	-0.7475	-0.8421	*****	*****	*****	*****	*****
0.700	-0.5521	-0.3134	-0.9187	-0.9901	-0.9011	*****	*****	*****	*****	*****
0.725	*****	-0.4559	*****	-1.1891	-0.6663	*****	*****	*****	*****	*****
0.750	-0.6021	-1.0759	*****	-1.2877	-0.5687	*****	*****	*****	*****	*****
0.775	*****	-1.3594	-1.3048	-1.0346	-0.5254	*****	*****	*****	*****	*****
0.800	-0.6460	-1.3000	-1.2405	-0.8655	*****	*****	*****	*****	*****	*****
0.825	*****	-1.3907	-1.1662	-0.7918	-0.5149	*****	*****	*****	*****	*****
0.850	-0.9401	-1.3375	-1.0531	-0.7725	-0.4936	*****	*****	*****	*****	*****
0.875	*****	-1.2767	-0.9643	-0.7635	-0.5108	*****	*****	*****	*****	*****
0.900	-1.1903	-1.2202	-0.9150	-0.7126	-0.5227	*****	*****	*****	*****	*****
0.925	*****	-1.1655	-0.8662	-0.6884	-0.5170	*****	*****	*****	*****	*****
0.950	-1.3044	-1.1238	-0.8215	-0.7484	-0.4466	*****	*****	*****	*****	*****
0.975	*****	-1.0971	-0.7991	-0.6663	-0.3759	*****	*****	*****	*****	*****
1.000	-1.2643	-1.3818	-0.8888	-1.0541	-0.5240	*****	*****	*****	*****	*****
-0.200	$C_{p,l}$	0.2841	0.2628	0.2748	*****	*****	*****	*****	*****	*****
-0.400	0.2799	0.2740	0.2499	0.0726	-0.6944	*****	*****	*****	*****	*****
-0.600	0.2984	0.2791	0.2471	0.1066	-0.6750	*****	*****	*****	*****	*****
-0.700	0.3168	0.2801	0.2548	0.1257	-0.6391	*****	*****	*****	*****	*****
-0.800	0.3319	*****	0.2530	0.1519	-0.5615	*****	*****	*****	*****	*****
-0.850	*****	0.3083	0.2622	0.1640	-0.5488	*****	*****	*****	*****	*****
-0.900	*****	0.3080	0.2699	0.1833	-0.5093	*****	*****	*****	*****	*****
-0.950	0.2387	0.2565	0.2445	0.1879	-0.1677	*****	*****	*****	*****	*****
-0.975	*****	0.1379	0.1613	0.1358	-0.0419	*****	*****	*****	*****	*****
-1.000	-1.2461	-1.2135	-1.0676	-1.0940	-0.5418	*****	*****	*****	*****	*****

Medium Radius L.E.
 Run No. = 34 , Point No. = 680
 $C_N = 0.582$, $C_m = -0.0877$
 $\alpha = 12.5^\circ$, $M_\infty = 0.830$
 $R_{mac} = 119.8 \times 10^6$

Leading Edge Pressures



x/c_R	starb'd C_p	port C_p
0.10	-0.8202	*****
0.20	-1.2643	-1.2461
0.30	-1.3759	*****
0.40	-1.3818	-1.2135
0.50	-1.1372	*****
0.60	-0.8888	-1.0676
0.70	-0.7812	*****
0.80	-1.0541	-1.0940
0.90	*****	*****
0.95	-0.5240	-0.5418

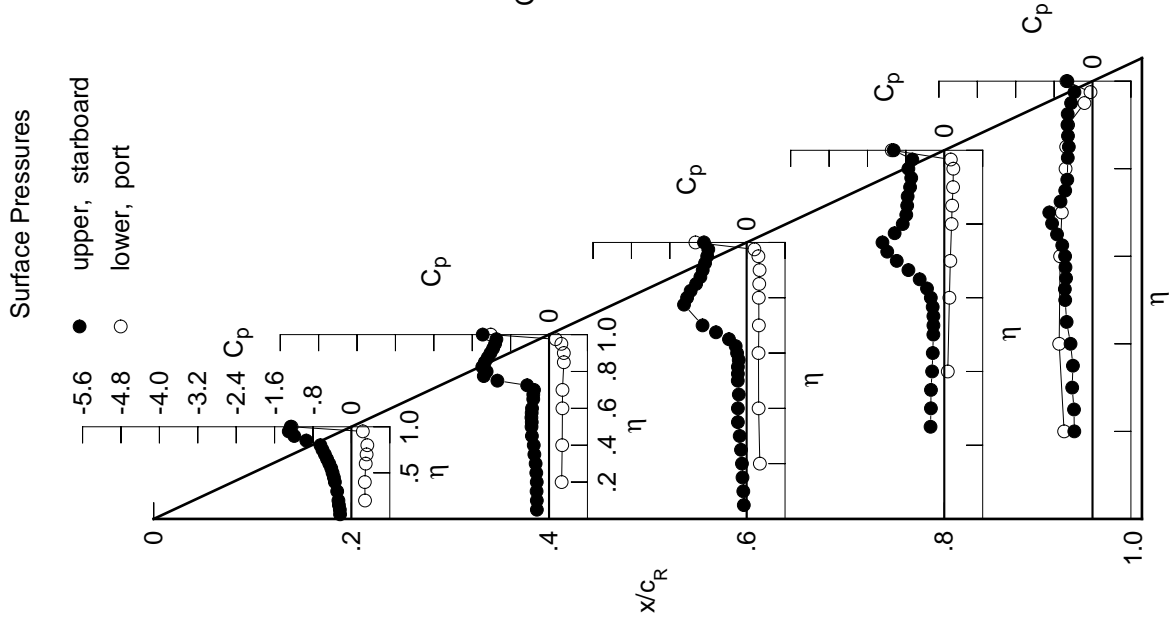
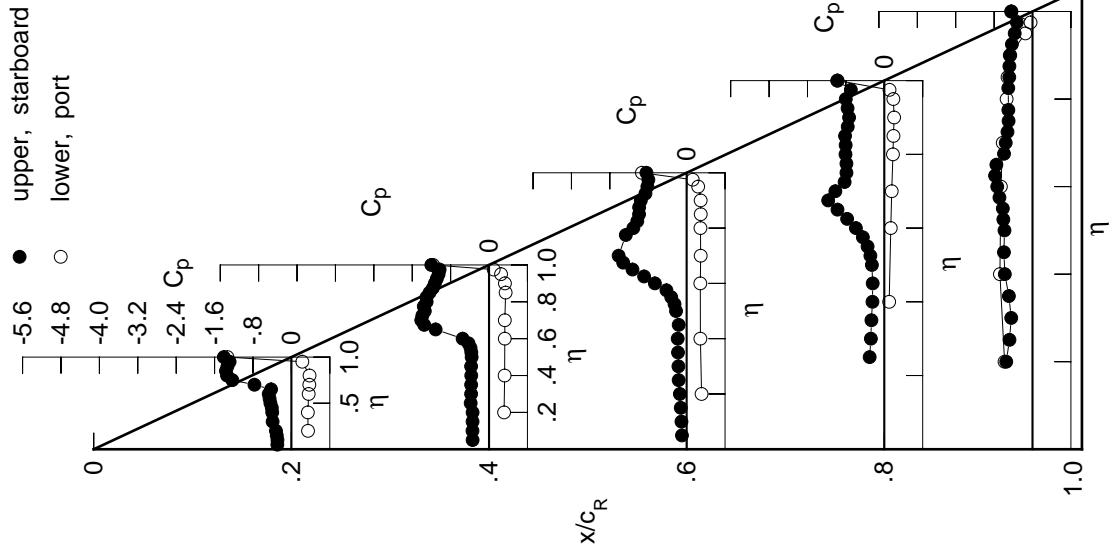

Table H2. Concluded.

η	x/c_R .2	x/c_R .4	x/c_R .6	x/c_R .8	x/c_R .95
	$C_{p,u}$	$C_{p,u}$	$C_{p,u}$	$C_{p,u}$	$C_{p,u}$
0.050	-0.2929	-0.3422	-0.0979	*****	*****
0.100	-0.2907	-0.3447	-0.1082	*****	*****
0.150	-0.3047	-0.3433	-0.1227	*****	*****
0.200	-0.3216	-0.3427	-0.1418	*****	-0.5469
0.250	*****	-0.3820	-0.1667	-0.3046	-0.4796
0.300	-0.3908	-0.3737	-0.1710	-0.2793	-0.4433
0.350	*****	-0.3732	-0.1797	-0.2681	-0.4923
0.400	-0.3988	-0.3703	-0.1867	-0.2461	-0.5766
0.450	-0.4083	-0.3738	-0.1655	-0.2417	-0.5953
0.500	-0.4366	-0.3622	-0.2207	-0.2586	-0.5840
0.525	*****	-0.3692	-0.2522	-0.2898	-0.6082
0.550	-0.4542	-0.3857	-0.3210	-0.3480	-0.6182
0.575	*****	-0.4280	-0.4206	-0.4463	-0.6885
0.600	-0.4727	-0.5507	-0.6617	-0.5921	-0.7345
0.625	*****	*****	-0.8865	-0.7742	-0.7803
0.650	-0.4234	-1.1125	-1.1278	-0.9751	-0.7525
0.675	*****	-1.3512	-1.3216	-1.1691	-0.5933
0.700	-0.7694	-1.4121	-1.4171	-1.0192	-0.5584
0.725	*****	-1.3899	*****	-0.8268	-0.5213
0.750	-1.2304	-1.3383	*****	-0.7882	-0.4981
0.775	*****	-1.3592	-1.2673	-0.7888	-0.5029
0.800	-1.3405	-1.2998	-1.1103	-0.8080	*****
0.825	*****	-1.3022	-1.0279	-0.8049	-0.5048
0.850	-1.3634	-1.2385	-0.9911	-0.8179	-0.4837
0.875	*****	-1.1695	-0.9899	-0.7617	-0.4814
0.900	-1.3323	-1.1286	-0.9544	-0.7335	-0.4641
0.925	*****	-1.0879	-0.8587	-0.7648	-0.4293
0.950	-1.2875	-1.0500	-0.8181	-0.8020	-0.3708
0.975	*****	-1.0299	-0.7976	-0.6970	-0.3264
1.000	-1.4068	-1.2023	-0.8378	-0.9806	-0.4393
	$C_{p,l}$	$C_{p,l}$	$C_{p,l}$	$C_{p,l}$	$C_{p,l}$
-0.200	0.3466	0.3134	0.3112	*****	-0.5821
-0.400	0.3433	0.3252	0.2867	0.1018	-0.6790
-0.600	0.3603	0.3284	0.2847	0.1354	-0.6595
-0.700	0.3739	0.3291	0.2924	0.1549	-0.6201
-0.800	0.3787	*****	0.2882	0.1807	-0.5392
-0.850	*****	0.3454	0.2940	0.1909	-0.5204
-0.900	*****	0.3315	0.2919	0.2050	-0.4737
-0.950	0.2281	0.2506	0.2401	0.1886	-0.1487
-0.975	*****	0.0970	0.1272	0.1084	-0.0406
-1.000	-1.3318	-1.1661	-0.9319	-0.9718	-0.4449

Surface Pressures



Medium Radius L.E.
 Run No. = 34, Point No. = 681
 $C_N = 0.685$, $C_m = -0.0932$
 $\alpha = 14.7^\circ$, $M_\infty = 0.830$
 $R_{mac} = 119.9 \times 10^6$

Leading Edge Pressures

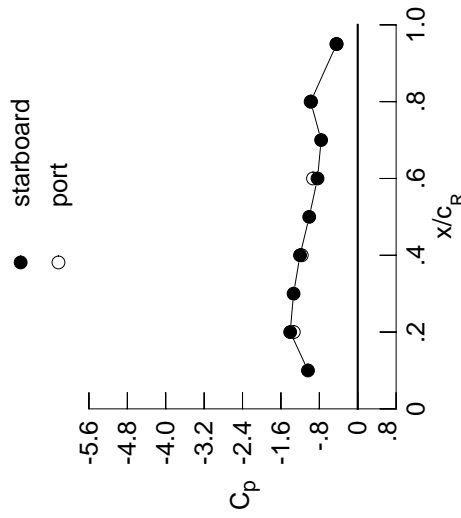

x/c_R	starb'd C_p	port C_p
0.10	-1.0367	*****
0.20	-1.4068	-1.3318
0.30	-1.3371	*****
0.40	-1.2023	-1.1661
0.50	-1.0108	*****
0.60	-0.8378	-0.9319
0.70	-0.7623	*****
0.80	-0.9806	-0.9718
0.90	*****	*****
0.95	-0.4393	-0.4449

Table H3. Tabulations and Plots of Surface Pressure Coefficients.

η	$x/c_R = .2$		$x/c_R = .4$		$x/c_R = .6$		$x/c_R = .8$		$x/c_R = .95$	
	$C_{p,u}$	$C_{p,u}$	$C_{p,u}$	$C_{p,u}$	$C_{p,u}$	$C_{p,u}$	$C_{p,u}$	$C_{p,u}$	$C_{p,u}$	$C_{p,u}$
0.050	0.0026	0.0172	0.1438	*****	*****	*****	*****	*****	*****	
0.100	0.0059	0.0177	0.1353	*****	*****	*****	*****	*****	*****	
0.150	0.0018	0.0175	0.1226	*****	*****	*****	*****	*****	*****	
0.200	0.0032	0.0223	0.1117	*****	*****	*****	*****	*****	*****	
0.250	*****	0.0160	0.0981	-0.1215	-0.6953	*****	*****	*****	*****	
0.300	-0.0054	0.0171	0.0891	-0.1050	-0.7469	*****	*****	*****	*****	
0.350	*****	0.0161	0.0789	-0.0942	-0.7363	*****	*****	*****	*****	
0.400	-0.0209	0.0151	0.0722	-0.0820	-0.7364	*****	*****	*****	*****	
0.450	-0.0268	0.0117	0.0818	-0.0742	-0.7138	*****	*****	*****	*****	
0.500	-0.0331	0.0112	0.0548	-0.0677	-0.7139	*****	*****	*****	*****	
0.525	*****	0.0076	0.0530	-0.0670	-0.7182	*****	*****	*****	*****	
0.550	-0.0301	0.0004	0.0494	-0.0626	-0.7186	*****	*****	*****	*****	
0.575	*****	0.0013	0.0562	-0.0623	-0.7295	*****	*****	*****	*****	
0.600	-0.0381	-0.0027	0.0398	-0.0615	-0.7287	*****	*****	*****	*****	
0.625	*****	*****	0.0422	-0.0569	-0.7261	*****	*****	*****	*****	
0.650	-0.0365	-0.0008	0.0360	-0.0557	-0.7284	*****	*****	*****	*****	
0.675	*****	-0.0142	0.0299	-0.0583	-0.7174	*****	*****	*****	*****	
0.700	-0.0292	-0.0209	0.0282	-0.0561	-0.7212	*****	*****	*****	*****	
0.725	*****	-0.0283	*****	-0.0545	-0.7181	*****	*****	*****	*****	
0.750	-0.0211	-0.0342	*****	-0.0537	-0.7103	*****	*****	*****	*****	
0.775	*****	-0.0371	0.0080	-0.0593	-0.7004	*****	*****	*****	*****	
0.800	0.0018	-0.0404	-0.0040	-0.0651	*****	*****	*****	*****	*****	
0.825	*****	-0.0367	-0.0140	-0.0575	-0.6872	*****	*****	*****	*****	
0.850	0.0257	-0.0331	-0.0225	-0.0793	-0.6733	*****	*****	*****	*****	
0.875	*****	-0.0201	-0.0270	-0.0865	-0.7162	*****	*****	*****	*****	
0.900	0.0561	-0.0095	-0.0234	-0.0945	-0.7354	*****	*****	*****	*****	
0.925	*****	0.0168	-0.0096	-0.0855	-1.0335	*****	*****	*****	*****	
0.950	0.1063	0.0535	0.0224	-0.0551	-0.3670	*****	*****	*****	*****	
0.975	*****	0.1100	0.0815	0.0049	-0.1968	*****	*****	*****	*****	
1.000	0.2222	0.2159	0.1869	0.1520	0.0731	*****	*****	*****	*****	
-0.200	$C_{p,l}$	$C_{p,l}$	$C_{p,l}$	$C_{p,l}$	$C_{p,l}$	$C_{p,l}$	$C_{p,l}$	$C_{p,l}$	$C_{p,l}$	
-0.400	-0.0270	-0.0038	0.0854	*****	*****	-0.7013	*****	*****	*****	
-0.600	-0.0540	-0.0032	0.0456	-0.1016	-0.7247	*****	*****	*****	*****	
-0.700	-0.0782	-0.0292	0.0156	-0.0831	-0.7358	*****	*****	*****	*****	
-0.800	-0.0804	-0.0672	-0.0063	-0.0830	-0.7373	*****	*****	*****	*****	
-0.850	-0.0661	*****	-0.0588	-0.0970	-0.7141	*****	*****	*****	*****	
-0.900	*****	-0.1012	-0.0914	-0.1267	-0.7460	*****	*****	*****	*****	
-0.950	*****	-0.0901	-0.1092	-0.1653	-0.4791	*****	*****	*****	*****	
-0.975	0.0332	-0.0410	-0.0792	-0.1590	-0.3756	*****	*****	*****	*****	
-1.000	0.1868	0.0093	-0.0324	-0.1061	-0.2750	*****	*****	*****	*****	
						0.1868	0.1838	0.1432	0.1323	0.0535

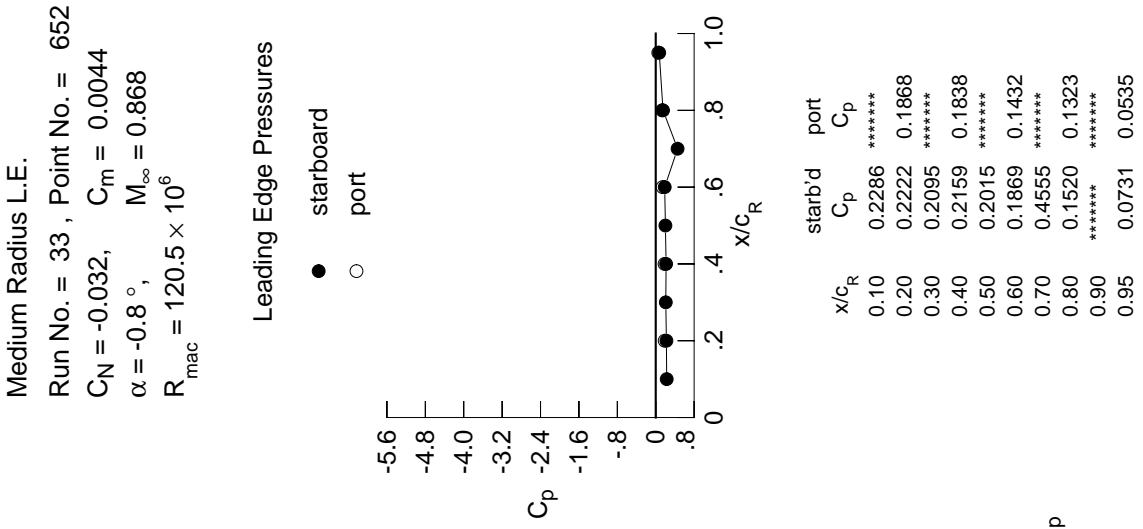

Medium Radius L.E.
 Run No. = 33, Point No. = 652
 $C_N = -0.032$, $C_m = 0.0044$
 $\alpha = -0.8^\circ$, $M_\infty = 0.868$
 $R_{mac} = 120.5 \times 10^6$

x/c_R	starb'd C_p	port C_p
0.10	0.2286	*****
0.20	0.2222	0.1868
0.30	0.2095	*****
0.40	0.2159	0.1838
0.50	0.2015	*****
0.60	0.1869	0.1432
0.70	0.4555	*****
0.80	0.1520	0.1323
0.90	*****	*****
0.95	0.0731	0.0535

Table H3. Continued.

η	$x/c_R = .2$		$x/c_R = .4$		$x/c_R = .6$		$x/c_R = .8$		$x/c_R = .95$	
	$C_{p,u}$	$C_{p,u}$	$C_{p,u}$	$C_{p,u}$	$C_{p,u}$	$C_{p,u}$	$C_{p,u}$	$C_{p,u}$	$C_{p,u}$	$C_{p,u}$
0.050	-0.0039	0.0119	0.1405	*****	*****	*****	*****	*****	*****	
0.100	0.0002	0.0122	0.1321	*****	*****	*****	*****	*****	*****	
0.150	-0.0045	0.0118	0.1190	*****	*****	*****	*****	*****	*****	
0.200	-0.0037	0.0172	0.1082	*****	*****	*****	*****	*****	-0.4611	
0.250	*****	0.0107	0.0946	-0.1260	-0.7042	*****	*****	*****	*****	
0.300	-0.0120	0.0120	0.0851	-0.1094	-0.7480	*****	*****	*****	*****	
0.350	*****	0.0101	0.0752	-0.0985	-0.7396	*****	*****	*****	*****	
0.400	-0.0282	0.0093	0.0677	-0.0865	-0.7468	*****	*****	*****	*****	
0.450	-0.0338	0.0051	0.0777	-0.0792	-0.7402	*****	*****	*****	*****	
0.500	-0.0411	0.0049	0.0498	-0.0724	-0.7408	*****	*****	*****	*****	
0.525	*****	0.0009	0.0482	-0.0718	-0.7389	*****	*****	*****	*****	
0.550	-0.0388	-0.0063	0.0444	-0.0677	-0.7382	*****	*****	*****	*****	
0.575	*****	-0.0057	0.0509	-0.0671	-0.7449	*****	*****	*****	*****	
0.600	-0.0472	-0.0098	0.0350	-0.0664	-0.7410	*****	*****	*****	*****	
0.625	*****	*****	0.0360	-0.0624	-0.7343	*****	*****	*****	*****	
0.650	-0.0466	-0.0087	0.0307	-0.0612	-0.7329	*****	*****	*****	*****	
0.675	*****	-0.0219	0.0231	-0.0641	-0.7195	*****	*****	*****	*****	
0.700	-0.0403	-0.0299	0.0217	-0.0624	-0.7241	*****	*****	*****	*****	
0.725	*****	-0.0379	*****	-0.0617	-0.7204	*****	*****	*****	*****	
0.750	-0.0330	-0.0445	*****	-0.0606	-0.7130	*****	*****	*****	*****	
0.775	*****	-0.0485	-0.0003	-0.0674	-0.7042	*****	*****	*****	*****	
0.800	-0.0109	-0.0522	-0.0136	-0.0730	*****	*****	*****	*****	*****	
0.825	*****	-0.0497	-0.0248	-0.0662	-0.6905	*****	*****	*****	*****	
0.850	0.0130	-0.0468	-0.0350	-0.0895	-0.6748	*****	*****	*****	*****	
0.875	*****	-0.0353	-0.0407	-0.0988	-0.7227	*****	*****	*****	*****	
0.900	0.0428	-0.0252	-0.0392	-0.1087	-0.7183	*****	*****	*****	*****	
0.925	*****	-0.0003	-0.0268	-0.1027	-0.9691	*****	*****	*****	*****	
0.950	0.0932	0.0364	0.0036	-0.0743	-0.3777	*****	*****	*****	*****	
0.975	*****	0.0924	0.0620	-0.0169	-0.2132	*****	*****	*****	*****	
1.000	0.2269	0.2246	0.2063	0.1665	0.0831	*****	*****	*****	*****	
-0.200	$C_{p,l}$	$C_{p,l}$	$C_{p,l}$	$C_{p,l}$	$C_{p,l}$	$C_{p,l}$	$C_{p,l}$	$C_{p,l}$	$C_{p,l}$	
-0.400	-0.0200	0.0020	0.0904	*****	*****	-0.7030	*****	*****	*****	
-0.600	-0.0464	0.0024	0.0509	-0.0970	-0.7516	*****	*****	*****	*****	
-0.700	-0.0685	-0.0218	0.0221	-0.0778	-0.7544	*****	*****	*****	*****	
-0.800	-0.0688	-0.0573	0.0018	-0.0769	-0.7373	*****	*****	*****	*****	
-0.850	-0.0523	*****	-0.0478	-0.0878	-0.7076	*****	*****	*****	*****	
-0.900	*****	-0.0854	-0.0772	-0.1155	-0.7388	*****	*****	*****	*****	
-0.950	*****	-0.0718	-0.0907	-0.1489	-0.4976	*****	*****	*****	*****	
-0.975	0.0511	-0.0195	-0.0551	-0.1355	-0.3615	*****	*****	*****	*****	
-1.000	0.0324	-0.0052	-0.0785	-0.2543	*****	*****	*****	*****	*****	
	0.1942	0.1962	0.1604	0.1534	0.0662	*****	*****	*****	*****	

Medium Radius L.E.
 Run No. = 33 , Point No. = 653
 $C_N = -0.017$, $C_m = 0.0017$
 $\alpha = -0.4^\circ$, $M_\infty = 0.869$
 $R_{mac} = 120.7 \times 10^6$

Leading Edge Pressures

● starboard
 ○ port

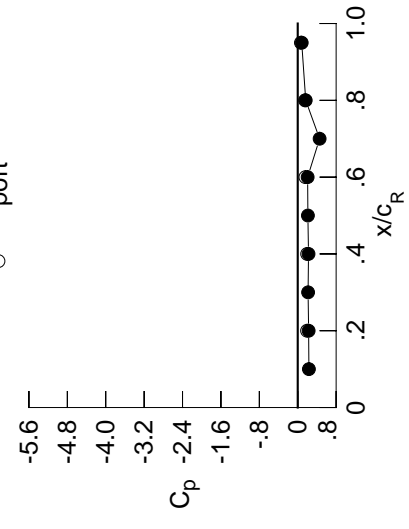

x/c_R	starb'd C_p	port C_p
0.10	0.2326	*****
0.20	0.2269	0.1942
0.30	0.2157	*****
0.40	0.2246	0.1962
0.50	0.2116	*****
0.60	0.2063	0.1604
0.70	0.4556	*****
0.80	0.1665	0.1534
0.90	*****	*****
0.95	0.0831	0.0662

Surface Pressures

● upper, starboard
 ○ lower, port

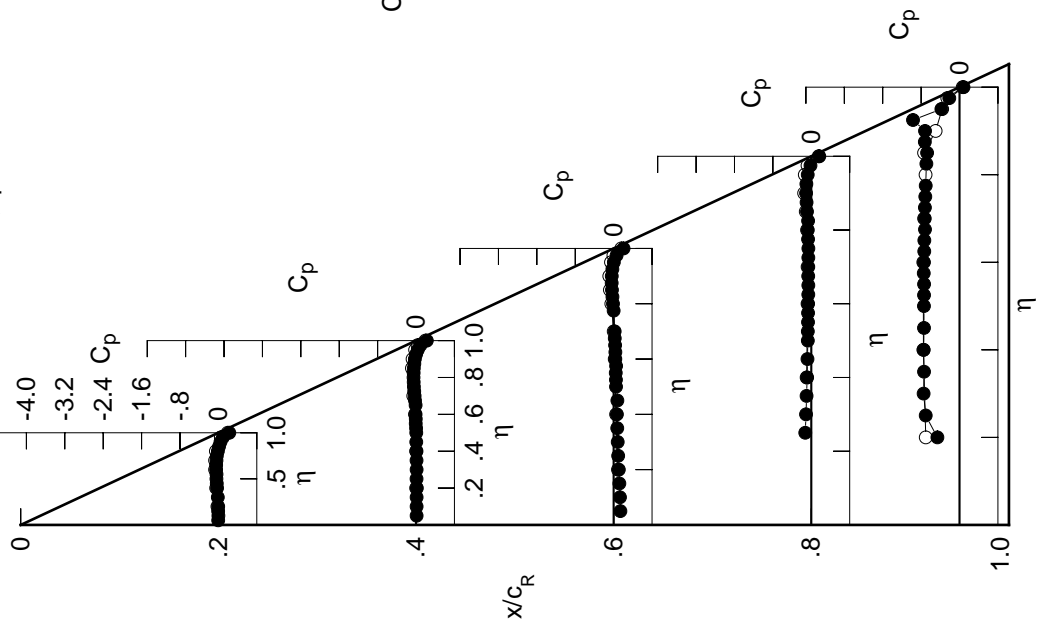

Table H3. Continued.

η	$x/c_R = .2$		$x/c_R = .4$		$x/c_R = .6$		$x/c_R = .8$		$x/c_R = .95$	
	$C_{p,u}$	$C_{p,u}$	$C_{p,u}$	$C_{p,u}$	$C_{p,u}$	$C_{p,u}$	$C_{p,u}$	$C_{p,u}$	$C_{p,u}$	$C_{p,u}$
0.050	-0.0248	-0.0070	0.1270	*****	*****	*****	*****	*****	*****	
0.100	-0.0213	-0.0069	0.1188	*****	*****	*****	*****	*****	*****	
0.150	-0.0255	-0.0072	0.1056	*****	*****	*****	*****	*****	*****	
0.200	-0.0246	-0.0032	0.0941	*****	*****	*****	*****	*****	-0.4248	
0.250	*****	-0.0088	0.0805	0.1388	-0.1388	-0.6851	*****	*****	*****	
0.300	-0.0336	-0.0087	0.0708	-0.1222	-0.7539	*****	*****	*****	*****	
0.350	*****	-0.0103	0.0599	-0.1117	-0.7449	*****	*****	*****	*****	
0.400	-0.0525	-0.0121	0.0523	-0.0997	-0.7515	*****	*****	*****	*****	
0.450	-0.0601	-0.0166	0.0609	-0.0927	-0.7415	*****	*****	*****	*****	
0.500	-0.0684	-0.0180	0.0327	-0.0866	-0.7438	*****	*****	*****	*****	
0.525	*****	-0.0224	0.0307	-0.0869	-0.7434	*****	*****	*****	*****	
0.550	-0.0685	-0.0307	0.0259	-0.0829	-0.7434	*****	*****	*****	*****	
0.575	*****	-0.0313	0.0321	-0.0831	-0.7517	*****	*****	*****	*****	
0.600	-0.0785	-0.0360	0.0152	-0.0833	-0.7486	*****	*****	*****	*****	
0.625	*****	*****	0.0158	-0.0798	-0.7425	*****	*****	*****	*****	
0.650	-0.0806	-0.0365	0.0092	-0.0785	-0.7419	*****	*****	*****	*****	
0.675	*****	-0.0514	0.0006	-0.0831	-0.7293	*****	*****	*****	*****	
0.700	-0.0770	-0.0616	-0.0017	-0.0821	-0.7348	*****	*****	*****	*****	
0.725	*****	-0.0717	*****	-0.0822	-0.7318	*****	*****	*****	*****	
0.750	-0.0718	-0.0807	*****	-0.0830	-0.7262	*****	*****	*****	*****	
0.775	*****	-0.0874	-0.0305	-0.0916	-0.7186	*****	*****	*****	*****	
0.800	-0.0527	-0.0949	-0.0475	-0.1003	*****	*****	*****	*****	*****	
0.825	*****	-0.0957	-0.0628	-0.0950	-0.6947	*****	*****	*****	*****	
0.850	-0.0314	-0.0961	-0.0780	-0.1240	-0.6767	*****	*****	*****	*****	
0.875	*****	-0.0888	-0.0897	-0.1399	-0.7428	*****	*****	*****	*****	
0.900	-0.0045	-0.0823	-0.0944	-0.1587	-0.5571	*****	*****	*****	*****	
0.925	*****	-0.0617	-0.0891	-0.1609	-0.7436	*****	*****	*****	*****	
0.950	0.0437	-0.0282	-0.0660	-0.1422	-0.4155	*****	*****	*****	*****	
0.975	*****	0.0224	-0.0133	-0.0941	-0.2712	*****	*****	*****	*****	
1.000	0.2228	0.2167	0.2038	0.1573	0.0787	*****	*****	*****	*****	
-0.200	$C_{p,l}$	$C_{p,l}$	$C_{p,l}$	$C_{p,l}$	$C_{p,l}$	$C_{p,l}$	$C_{p,l}$	$C_{p,l}$	$C_{p,l}$	
-0.400	0.0007	0.0208	0.1042	*****	-0.6987	*****	*****	*****	*****	
-0.600	-0.0224	0.0230	0.0667	-0.0831	-0.7483	*****	*****	*****	*****	
-0.700	-0.0376	0.0032	0.0415	-0.0610	-0.7459	*****	*****	*****	*****	
-0.800	-0.0326	-0.0264	0.0249	-0.0569	-0.7263	*****	*****	*****	*****	
-0.850	-0.0108	*****	-0.0160	-0.0613	-0.6906	*****	*****	*****	*****	
-0.900	*****	-0.0377	-0.0359	-0.0815	-0.7159	*****	*****	*****	*****	
-0.950	*****	-0.0165	-0.0379	-0.1011	-0.5937	*****	*****	*****	*****	
-0.975	0.1008	0.0426	0.0099	-0.0703	-0.3252	*****	*****	*****	*****	
-1.000	*****	0.0988	0.0671	-0.0046	-0.1990	*****	*****	*****	*****	
	0.1940	0.1976	0.1624	0.1620	0.0725	*****	*****	*****	*****	

Medium Radius L.E.
 Run No. = 33, Point No. = 654
 $C_N = 0.027$, $C_m = -0.0058$
 $\alpha = 0.6^\circ$, $M_\infty = 0.870$
 $R_{mac} = 120.6 \times 10^6$

Leading Edge Pressures

● starboard
 ○ port

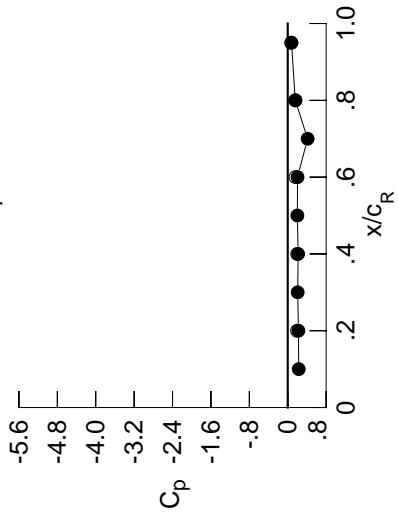

x/c_R	starb'd C_p	port C_p
0.10	0.2295	*****
0.20	0.2228	0.1940
0.30	0.2076	*****
0.40	0.2167	0.1976
0.50	0.2006	*****
0.60	0.2038	0.1624
0.70	0.4141	*****
0.80	0.1573	0.1620
0.90	*****	*****
0.95	0.0787	0.0725

Surface Pressures

● upper, starboard
 ○ lower, port

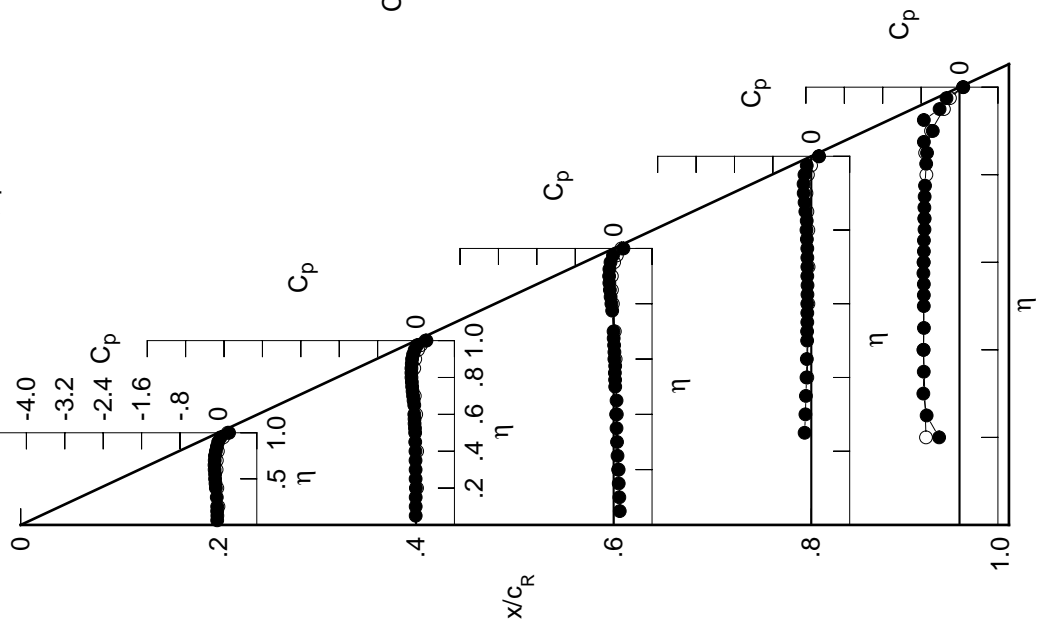

Table H3. Continued.

η	$x/c_R = .2$		$x/c_R = .4$		$x/c_R = .6$		$x/c_R = .8$		$x/c_R = .95$	
	$C_{p,u}$	$C_{p,u}$	$C_{p,u}$	$C_{p,u}$	$C_{p,u}$	$C_{p,u}$	$C_{p,u}$	$C_{p,u}$	$C_{p,u}$	$C_{p,u}$
0.050	-0.0450	-0.0251	0.1143	*****	*****	*****	*****	*****	*****	*****
0.100	-0.0421	-0.0248	0.1057	*****	*****	*****	*****	*****	*****	*****
0.150	-0.0461	-0.0258	0.0927	*****	*****	*****	*****	*****	*****	*****
0.200	-0.0459	-0.0209	0.0811	*****	*****	*****	*****	*****	*****	*****
0.250	*****	-0.0274	0.0665	-0.1525	-0.6483	*****	*****	*****	*****	*****
0.300	-0.0556	-0.0269	0.0564	-0.1361	-0.7573	*****	*****	*****	*****	*****
0.350	*****	-0.0298	0.0452	-0.1260	-0.7482	*****	*****	*****	*****	*****
0.400	-0.0767	-0.0317	0.0374	-0.1143	-0.7470	*****	*****	*****	*****	*****
0.450	-0.0862	-0.0376	0.0445	-0.1077	-0.7280	*****	*****	*****	*****	*****
0.500	-0.0960	-0.0397	0.0154	-0.1026	-0.7365	*****	*****	*****	*****	*****
0.525	*****	-0.0453	0.0127	-0.1030	-0.7397	*****	*****	*****	*****	*****
0.550	-0.0984	-0.0546	0.0076	-0.0996	-0.7411	*****	*****	*****	*****	*****
0.575	*****	-0.0553	0.0130	-0.0999	-0.7497	*****	*****	*****	*****	*****
0.600	-0.1108	-0.0615	-0.0048	-0.1012	-0.7474	*****	*****	*****	*****	*****
0.625	*****	*****	-0.0044	-0.0981	-0.7460	*****	*****	*****	*****	*****
0.650	-0.1160	-0.0647	-0.0124	-0.0981	-0.7492	*****	*****	*****	*****	*****
0.675	*****	-0.0818	-0.0219	-0.1033	-0.7395	*****	*****	*****	*****	*****
0.700	-0.1150	-0.0939	-0.0264	-0.1037	-0.7467	*****	*****	*****	*****	*****
0.725	*****	-0.1067	*****	-0.1051	-0.7455	*****	*****	*****	*****	*****
0.750	-0.1130	-0.1189	*****	-0.1078	-0.7401	*****	*****	*****	*****	*****
0.775	*****	-0.1290	-0.0618	-0.1179	-0.7338	*****	*****	*****	*****	*****
0.800	-0.0975	-0.1401	-0.0827	-0.1304	*****	*****	*****	*****	*****	*****
0.825	*****	-0.1452	-0.1033	-0.1253	-0.7088	*****	*****	*****	*****	*****
0.850	-0.0797	-0.1499	-0.1246	-0.1614	-0.6841	*****	*****	*****	*****	*****
0.875	*****	-0.1470	-0.1427	-0.1847	-0.5893	*****	*****	*****	*****	*****
0.900	-0.0576	-0.1462	-0.1562	-0.2128	-0.4619	*****	*****	*****	*****	*****
0.925	*****	-0.1307	-0.1591	-0.2259	-0.5790	*****	*****	*****	*****	*****
0.950	-0.0141	-0.1034	-0.1464	-0.2206	-0.4605	*****	*****	*****	*****	*****
0.975	*****	-0.0638	-0.1072	-0.1881	-0.3413	*****	*****	*****	*****	*****
1.000	0.1897	0.1577	0.1234	0.0670	0.0170	*****	*****	*****	*****	*****
-0.200	$C_{p,l}$	$C_{p,l}$	$C_{p,l}$	$C_{p,l}$	$C_{p,l}$	$C_{p,l}$	$C_{p,l}$	$C_{p,l}$	$C_{p,l}$	$C_{p,l}$
-0.400	0.0241	0.0397	0.1179	*****	*****	*****	*****	*****	*****	*****
-0.600	0.0026	0.0433	0.0823	-0.0695	-0.7419	*****	*****	*****	*****	*****
-0.700	-0.0062	0.0284	0.0603	-0.0445	-0.7375	*****	*****	*****	*****	*****
-0.800	0.0027	0.0034	0.0484	-0.0376	-0.7161	*****	*****	*****	*****	*****
-0.850	0.0293	*****	0.0159	-0.0362	-0.6743	*****	*****	*****	*****	*****
-0.900	*****	0.0065	0.0045	-0.0479	-0.6934	*****	*****	*****	*****	*****
-0.950	0.1438	0.0957	0.0118	-0.0551	-0.7367	*****	*****	*****	*****	*****
-0.975	*****	0.1514	0.0673	-0.0113	-0.2938	*****	*****	*****	*****	*****
-1.000	0.1632	0.1484	0.0902	0.0898	0.0239	*****	*****	*****	*****	*****

Medium Radius L.E.
 Run No. = 33 , Point No. = 655
 $C_N = 0.071$, $C_m = -0.0124$
 $\alpha = 1.7^\circ$, $M_\infty = 0.868$
 $R_{mac} = 120.6 \times 10^6$

Leading Edge Pressures

● starboard
 ○ port

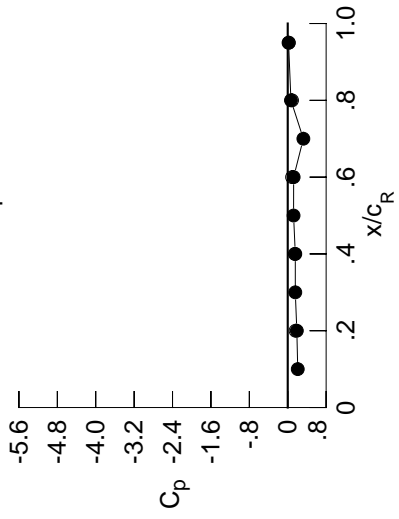

x/c_R	starb'd C_p	port C_p
0.10	0.2086	*****
0.20	0.1897	0.1632
0.30	0.1576	*****
0.40	0.1577	0.1484
0.50	0.1218	*****
0.60	0.1234	0.0902
0.70	0.3254	*****
0.80	0.0670	0.0898
0.90	*****	*****
0.95	0.0170	0.0239

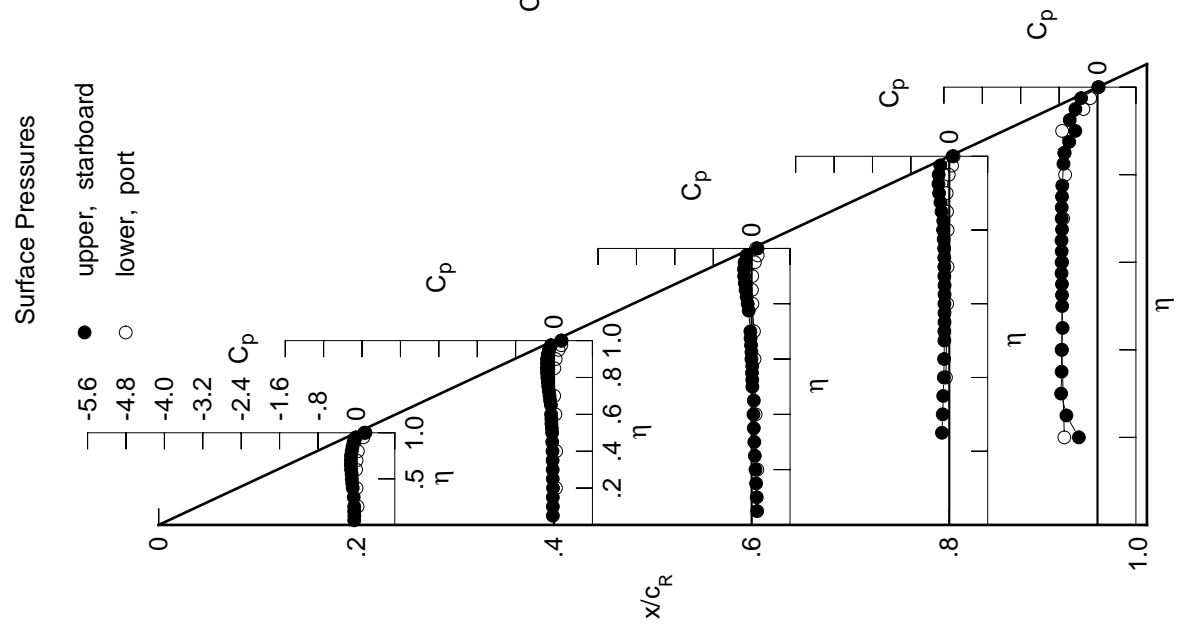

Table H3. Continued.

η	$x/c_R = .2$		$x/c_R = .4$		$x/c_R = .6$		$x/c_R = .8$		$x/c_R = .95$	
	$C_{p,u}$	$C_{p,l}$	$C_{p,u}$	$C_{p,l}$	$C_{p,u}$	$C_{p,l}$	$C_{p,u}$	$C_{p,l}$	$C_{p,u}$	$C_{p,l}$
0.050	-0.0649	-0.0444	0.1013	*****	*****	*****	*****	*****	*****	*****
0.100	-0.0621	-0.0442	0.0930	*****	*****	*****	*****	*****	*****	*****
0.150	-0.0667	-0.0450	0.0793	*****	*****	*****	*****	*****	*****	*****
0.200	-0.0670	-0.0408	0.0673	*****	*****	*****	*****	*****	*****	*****
0.250	*****	-0.0471	0.0532	-0.1669	-0.1669	-0.1669	-0.1669	-0.1669	-0.1669	-0.1669
0.300	-0.0780	-0.0476	0.0424	-0.1503	-0.1503	-0.1503	-0.1503	-0.1503	-0.1503	-0.1503
0.350	*****	-0.0510	0.0295	-0.1402	-0.1402	-0.1402	-0.1402	-0.1402	-0.1402	-0.1402
0.400	-0.1016	-0.0533	0.0212	-0.1293	-0.1293	-0.1293	-0.1293	-0.1293	-0.1293	-0.1293
0.450	-0.1125	-0.0602	0.0278	-0.1236	-0.1236	-0.1236	-0.1236	-0.1236	-0.1236	-0.1236
0.500	-0.1245	-0.0631	-0.0024	-0.1187	-0.1187	-0.1187	-0.1187	-0.1187	-0.1187	-0.1187
0.525	*****	-0.0696	-0.0053	-0.1195	-0.1195	-0.1195	-0.1195	-0.1195	-0.1195	-0.1195
0.550	-0.1292	-0.0796	-0.0119	-0.1162	-0.1162	-0.1162	-0.1162	-0.1162	-0.1162	-0.1162
0.575	*****	-0.0817	-0.0065	-0.1176	-0.1176	-0.1176	-0.1176	-0.1176	-0.1176	-0.1176
0.600	-0.1441	-0.0889	-0.0249	-0.1191	-0.1191	-0.1191	-0.1191	-0.1191	-0.1191	-0.1191
0.625	*****	*****	-0.0261	-0.1173	-0.1173	-0.1173	-0.1173	-0.1173	-0.1173	-0.1173
0.650	-0.1521	-0.0938	-0.0351	-0.1182	-0.1182	-0.1182	-0.1182	-0.1182	-0.1182	-0.1182
0.675	*****	-0.1127	-0.0457	-0.1243	-0.1243	-0.1243	-0.1243	-0.1243	-0.1243	-0.1243
0.700	-0.1548	-0.1273	-0.0521	-0.1260	-0.1260	-0.1260	-0.1260	-0.1260	-0.1260	-0.1260
0.725	*****	-0.1431	*****	-0.1293	-0.1293	-0.1293	-0.1293	-0.1293	-0.1293	-0.1293
0.750	-0.1565	-0.1588	*****	-0.1330	-0.1330	-0.1330	-0.1330	-0.1330	-0.1330	-0.1330
0.775	*****	-0.1724	-0.0950	-0.1460	-0.1460	-0.1460	-0.1460	-0.1460	-0.1460	-0.1460
0.800	-0.1453	-0.1882	-0.1196	-0.1614	-0.1614	-0.1614	-0.1614	-0.1614	-0.1614	-0.1614
0.825	*****	-0.1975	-0.1459	-0.1585	-0.1585	-0.1585	-0.1585	-0.1585	-0.1585	-0.1585
0.850	-0.1323	-0.2072	-0.1742	-0.2012	-0.2012	-0.2012	-0.2012	-0.2012	-0.2012	-0.2012
0.875	*****	-0.2105	-0.2010	-0.2333	-0.2333	-0.2333	-0.2333	-0.2333	-0.2333	-0.2333
0.900	-0.1160	-0.2145	-0.2230	-0.2723	-0.2723	-0.2723	-0.2723	-0.2723	-0.2723	-0.2723
0.925	*****	-0.2081	-0.2372	-0.2978	-0.2978	-0.2978	-0.2978	-0.2978	-0.2978	-0.2978
0.950	-0.0803	-0.1886	-0.2382	-0.3097	-0.3097	-0.3097	-0.3097	-0.3097	-0.3097	-0.3097
0.975	*****	-0.1644	-0.2197	-0.2980	-0.2980	-0.2980	-0.2980	-0.2980	-0.2980	-0.2980
1.000	0.1241	0.0457	0.0011	-0.1015	-0.1015	-0.1015	-0.1015	-0.1015	-0.1015	-0.1015
-0.200	$C_{p,l}$	$C_{p,l}$	$C_{p,l}$	$C_{p,l}$	$C_{p,l}$	$C_{p,l}$	$C_{p,l}$	$C_{p,l}$	$C_{p,l}$	$C_{p,l}$
-0.400	0.0457	0.0579	0.1316	*****	*****	*****	*****	*****	*****	*****
-0.600	0.0262	0.0633	0.0972	-0.0659	-0.0659	-0.0659	-0.0659	-0.0659	-0.0659	-0.0659
-0.700	0.0235	0.0519	0.0785	-0.0294	-0.0294	-0.0294	-0.0294	-0.0294	-0.0294	-0.0294
-0.800	0.0360	0.0324	0.0706	-0.0197	-0.0197	-0.0197	-0.0197	-0.0197	-0.0197	-0.0197
-0.850	0.0659	*****	0.0457	-0.0125	-0.0125	-0.0125	-0.0125	-0.0125	-0.0125	-0.0125
-0.900	*****	0.0473	0.0407	-0.0177	-0.0177	-0.0177	-0.0177	-0.0177	-0.0177	-0.0177
-0.950	*****	0.0786	0.0552	-0.0149	-0.0149	-0.0149	-0.0149	-0.0149	-0.0149	-0.0149
-0.975	0.1776	0.1390	0.1142	0.0369	0.0369	0.0369	0.0369	0.0369	0.0369	0.0369
-1.000	*****	0.1885	0.1674	0.1015	0.1015	0.1015	0.1015	0.1015	0.1015	0.1015
	0.0994	0.0432	-0.0710	-0.0592	-0.0592	-0.0592	-0.0592	-0.0592	-0.0592	-0.0592

Medium Radius L.E.

Run No. = 33, Point No. = 656

$C_N = 0.115$, $C_m = -0.0198$

$\alpha = 2.8^\circ$, $M_\infty = 0.870$

$R_{mac} = 120.5 \times 10^6$

Leading Edge Pressures

● starboard
○ port

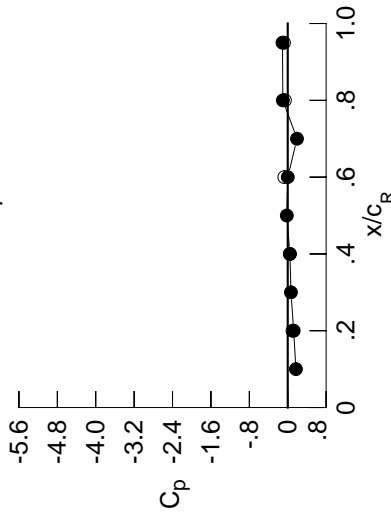

x/c_R	starb'd C_p	port C_p
0.10	0.1704	*****
0.20	0.1241	0.0994
0.30	0.0676	*****
0.40	0.0457	0.0432
0.50	-0.0196	*****
0.60	0.0011	-0.0710
0.70	0.1932	*****
0.80	-0.1015	-0.0592
0.90	*****	*****
0.95	-0.1100	-0.0773

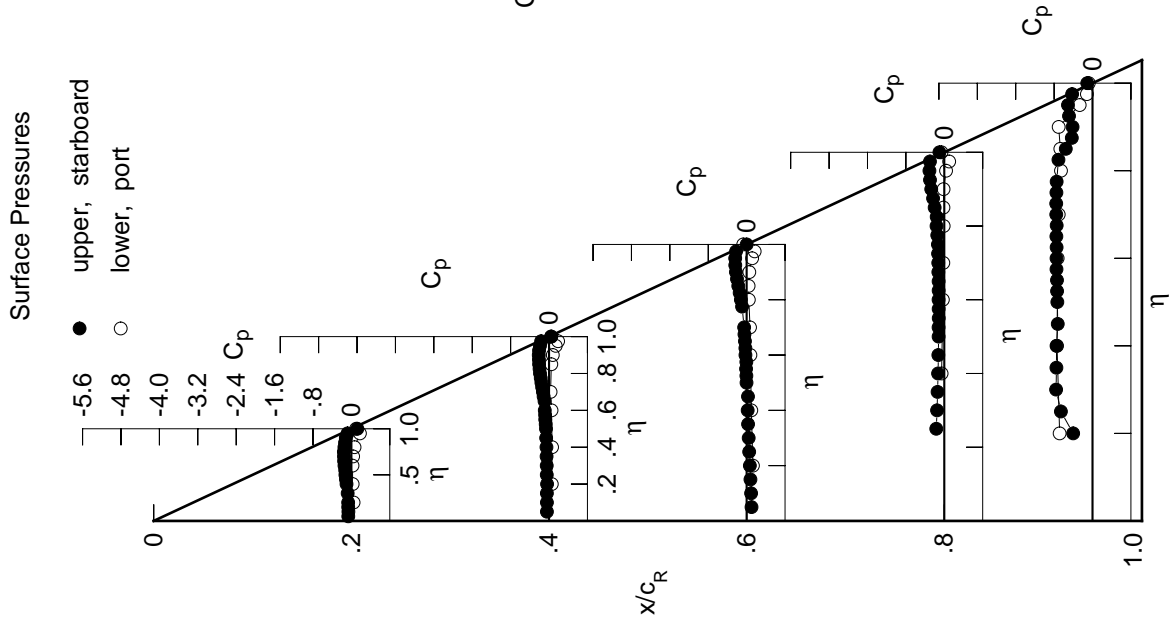
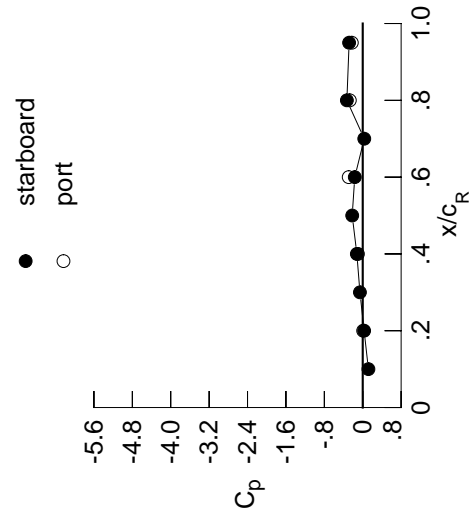

Table H3. Continued.

η	$x/c_R = .2$		$x/c_R = .4$		$x/c_R = .6$		$x/c_R = .8$		$x/c_R = .95$	
	$C_{p,u}$	$C_{p,u}$	$C_{p,u}$	$C_{p,u}$	$C_{p,u}$	$C_{p,u}$	$C_{p,u}$	$C_{p,u}$	$C_{p,u}$	$C_{p,u}$
0.050	-0.0834	-0.0612	0.0901	*****	*****	*****	*****	*****	*****	
0.100	-0.0815	-0.0608	0.0814	*****	*****	*****	*****	*****	*****	
0.150	-0.0855	-0.0623	0.0680	*****	*****	*****	*****	*****	*****	
0.200	-0.0865	-0.0576	0.0561	*****	*****	*****	*****	*****	-0.4104	
0.250	*****	-0.0646	0.0410	-0.1779	-0.16349	*****	*****	*****	*****	
0.300	-0.0980	-0.0655	0.0299	-0.1623	-0.7468	*****	*****	*****	*****	
0.350	*****	-0.0692	0.0170	-0.1525	-0.7436	*****	*****	*****	*****	
0.400	-0.1237	-0.0726	0.0079	-0.1416	-0.7306	*****	*****	*****	*****	
0.450	-0.1363	-0.0806	0.0137	-0.1361	-0.6883	*****	*****	*****	*****	
0.500	-0.1500	-0.0844	-0.0176	-0.1321	-0.6767	*****	*****	*****	*****	
0.525	*****	-0.0916	-0.0210	-0.1338	-0.6869	*****	*****	*****	*****	
0.550	-0.1571	-0.1026	-0.0280	-0.1310	-0.6875	*****	*****	*****	*****	
0.575	*****	-0.1058	-0.0243	-0.1326	-0.7007	*****	*****	*****	*****	
0.600	-0.1752	-0.1136	-0.0440	-0.1349	-0.6998	*****	*****	*****	*****	
0.625	*****	*****	-0.0453	-0.1338	-0.7012	*****	*****	*****	*****	
0.650	-0.1866	-0.1218	-0.0552	-0.1358	-0.7245	*****	*****	*****	*****	
0.675	*****	-0.1425	-0.0675	-0.1431	-0.7313	*****	*****	*****	*****	
0.700	-0.1928	-0.1598	-0.0748	-0.1459	-0.7550	*****	*****	*****	*****	
0.725	*****	-0.1783	*****	-0.1506	-0.7621	*****	*****	*****	*****	
0.750	-0.1992	-0.1972	*****	-0.1561	-0.7616	*****	*****	*****	*****	
0.775	*****	-0.2155	-0.1254	-0.1718	-0.7542	*****	*****	*****	*****	
0.800	-0.1927	-0.2351	-0.1558	-0.1905	*****	*****	*****	*****	*****	
0.825	*****	-0.2499	-0.1878	-0.1902	-0.6559	*****	*****	*****	*****	
0.850	-0.1849	-0.2645	-0.2229	-0.2383	-0.4513	*****	*****	*****	*****	
0.875	*****	-0.2745	-0.2584	-0.2802	-0.3796	*****	*****	*****	*****	
0.900	-0.1759	-0.2864	-0.2916	-0.3309	-0.3920	*****	*****	*****	*****	
0.925	*****	-0.2888	-0.3184	-0.3713	-0.4323	*****	*****	*****	*****	
0.950	-0.1512	-0.2816	-0.3373	-0.4007	-0.5665	*****	*****	*****	*****	
0.975	*****	-0.2771	-0.3420	-0.4197	-0.5191	*****	*****	*****	*****	
1.000	0.0288	-0.1222	-0.1660	-0.3304	-0.2836	*****	*****	*****	*****	
η	$C_{p,l}$	$C_{p,l}$	$C_{p,l}$	$C_{p,l}$	$C_{p,l}$	$C_{p,l}$	$C_{p,l}$	$C_{p,l}$	$C_{p,l}$	
-0.200	0.0684	0.0782	0.1454	*****	-0.6752	*****	*****	*****	*****	
-0.400	0.0509	0.0848	0.1132	-0.0419	-0.7287	*****	*****	*****	*****	
-0.600	0.0527	0.0765	0.0978	-0.0125	-0.7168	*****	*****	*****	*****	
-0.700	0.0678	0.0605	0.0919	-0.0009	-0.6921	*****	*****	*****	*****	
-0.800	0.1005	*****	0.0733	0.0110	-0.6411	*****	*****	*****	*****	
-0.850	*****	0.0845	0.0734	0.0092	-0.6502	*****	*****	*****	*****	
-0.900	*****	0.1173	0.0922	0.0196	-0.6684	*****	*****	*****	*****	
-0.950	0.2043	0.1731	0.1500	0.0754	-0.2456	*****	*****	*****	*****	
-0.975	*****	0.2113	0.1940	0.1322	-0.0902	*****	*****	*****	*****	
-1.000	0.0090	-0.0999	-0.2923	-0.2687	-0.2274	*****	*****	*****	*****	

Medium Radius L.E.
 Run No. = 33 , Point No. = 657
 $C_N = 0.158$, $C_m = -0.0269$
 $\alpha = 3.9^\circ$, $M_\infty = 0.869$
 $R_{mac} = 120.5 \times 10^6$

Leading Edge Pressures



x/c_R	starb'd C_p	port C_p
0.10	0.1183	*****
0.20	0.0288	0.0090
0.30	-0.0584	*****
0.40	-0.1222	-0.0999
0.50	-0.2194	*****
0.60	-0.1660	-0.2923
0.70	0.0317	*****
0.80	-0.3304	-0.2687
0.90	*****	*****
0.95	-0.2836	-0.2274

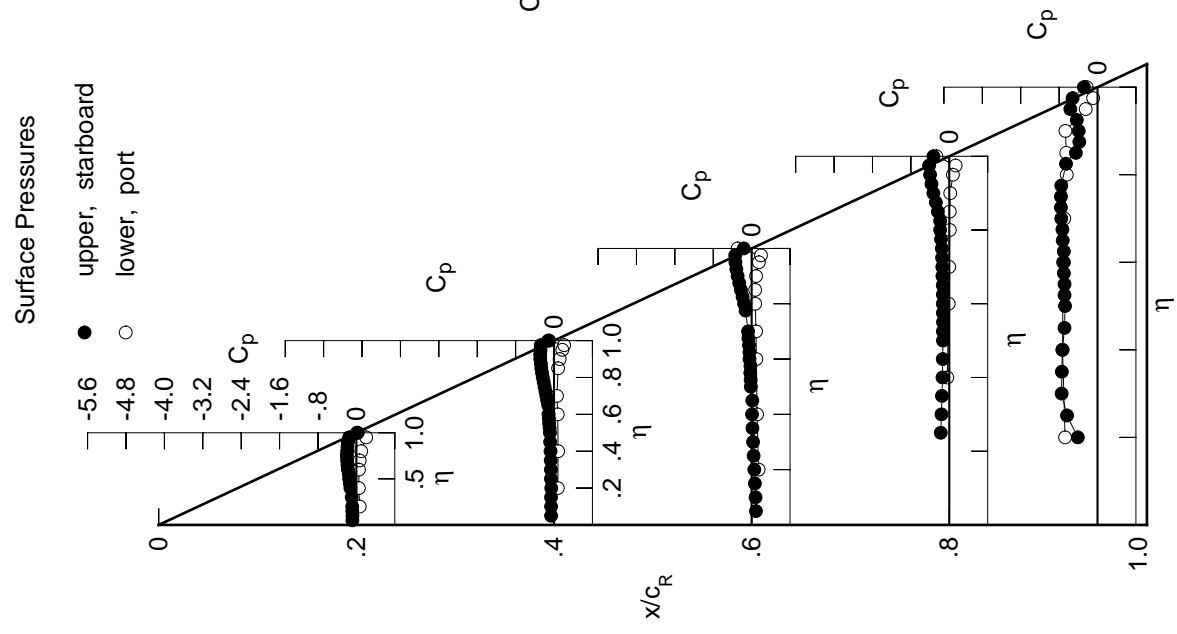

Table H3. Continued.

η	$x/c_R = .2$		$x/c_R = .4$		$x/c_R = .6$		$x/c_R = .8$		$x/c_R = .95$	
	$C_{p,u}$	$C_{p,u}$	$C_{p,u}$	$C_{p,u}$	$C_{p,u}$	$C_{p,u}$	$C_{p,u}$	$C_{p,u}$	$C_{p,u}$	$C_{p,u}$
0.050	-0.1023	-0.0785	0.0796	0.0796	0.0796	0.0796	0.0796	0.0796	0.0796	0.0796
0.100	-0.1007	-0.0786	0.0709	0.0709	0.0709	0.0709	0.0709	0.0709	0.0709	0.0709
0.150	-0.1055	-0.0804	0.0576	0.0576	0.0576	0.0576	0.0576	0.0576	0.0576	0.0576
0.200	-0.1068	-0.0765	0.0453	0.0453	0.0453	0.0453	0.0453	0.0453	0.0453	0.0453
0.250	*****	-0.0834	0.0297	0.0297	0.1898	0.1898	0.1898	0.1898	0.1898	0.1898
0.300	-0.1176	-0.0845	0.0184	0.0184	-0.1737	-0.1737	-0.1737	-0.1737	-0.1737	-0.1737
0.350	*****	-0.0897	0.0048	0.0048	-0.1651	-0.1651	-0.1651	-0.1651	-0.1651	-0.1651
0.400	-0.1466	-0.0930	-0.0061	-0.0061	-0.1537	-0.1537	-0.1537	-0.1537	-0.1537	-0.1537
0.450	-0.1606	-0.1023	0.0007	0.0007	-0.1488	-0.1488	-0.1488	-0.1488	-0.1488	-0.1488
0.500	-0.1767	-0.1068	-0.0327	-0.0327	-0.1457	-0.1457	-0.1457	-0.1457	-0.1457	-0.1457
0.525	*****	-0.1155	-0.0371	-0.0371	-0.1474	-0.1474	-0.1474	-0.1474	-0.1474	-0.1474
0.550	-0.1863	-0.1276	-0.0444	-0.0444	-0.1452	-0.1452	-0.1452	-0.1452	-0.1452	-0.1452
0.575	*****	-0.1319	-0.0420	-0.0420	-0.1481	-0.1481	-0.1481	-0.1481	-0.1481	-0.1481
0.600	-0.2072	-0.1407	-0.0624	-0.0624	-0.1516	-0.1516	-0.1516	-0.1516	-0.1516	-0.1516
0.625	*****	*****	-0.0648	-0.0648	-0.1509	-0.1509	-0.1509	-0.1509	-0.1509	-0.1509
0.650	-0.2225	-0.1506	-0.0765	-0.0765	-0.1530	-0.1530	-0.1530	-0.1530	-0.1530	-0.1530
0.675	*****	-0.1727	-0.0895	-0.0895	-0.1624	-0.1624	-0.1624	-0.1624	-0.1624	-0.1624
0.700	-0.2331	-0.1933	-0.0991	-0.0991	-0.1660	-0.1660	-0.1660	-0.1660	-0.1660	-0.1660
0.725	*****	-0.2146	*****	-0.1727	-0.1727	-0.17593	-0.1727	-0.17593	-0.1727	-0.17593
0.750	-0.2437	-0.2373	*****	-0.1803	-0.1803	-0.1803	-0.1803	-0.1803	-0.1803	-0.1803
0.775	*****	-0.2594	-0.1587	-0.1986	-0.1986	-0.1986	-0.1986	-0.1986	-0.1986	-0.1986
0.800	-0.2429	-0.2848	-0.1924	-0.2203	*****	*****	*****	*****	*****	*****
0.825	*****	-0.3056	-0.2308	-0.2226	-0.5913	-0.5913	-0.5913	-0.5913	-0.5913	-0.5913
0.850	-0.2420	-0.3267	-0.2735	-0.2783	-0.3961	-0.3961	-0.3961	-0.3961	-0.3961	-0.3961
0.875	*****	-0.3449	-0.3193	-0.3293	-0.3572	-0.3572	-0.3572	-0.3572	-0.3572	-0.3572
0.900	-0.2421	-0.3654	-0.3687	-0.3929	-0.3744	-0.3744	-0.3744	-0.3744	-0.3744	-0.3744
0.925	*****	-0.3789	-0.4114	-0.4504	-0.3990	-0.3990	-0.3990	-0.3990	-0.3990	-0.3990
0.950	-0.2315	-0.3837	-0.4541	-0.5041	-0.6289	-0.6289	-0.6289	-0.6289	-0.6289	-0.6289
0.975	*****	-0.4089	-0.5034	-0.5626	-0.6239	-0.6239	-0.6239	-0.6239	-0.6239	-0.6239
1.000	-0.0955	-0.3296	-0.3921	-0.6503	-0.5493	-0.5493	-0.5493	-0.5493	-0.5493	-0.5493
	$C_{p,l}$	$C_{p,l}$	$C_{p,l}$	$C_{p,l}$	$C_{p,l}$	$C_{p,l}$	$C_{p,l}$	$C_{p,l}$	$C_{p,l}$	$C_{p,l}$
-0.200	0.0923	0.0992	0.1620	*****	-0.6658	-0.6658	-0.6658	-0.6658	-0.6658	-0.6658
-0.400	0.0776	0.1061	0.1309	-0.0265	-0.7204	-0.7204	-0.7204	-0.7204	-0.7204	-0.7204
-0.600	0.0835	0.1011	0.1182	0.0044	-0.7059	-0.7059	-0.7059	-0.7059	-0.7059	-0.7059
-0.700	0.1019	0.0891	0.1143	0.0177	-0.6798	-0.6798	-0.6798	-0.6798	-0.6798	-0.6798
-0.800	0.1347	*****	0.0999	0.0332	-0.6249	-0.6249	-0.6249	-0.6249	-0.6249	-0.6249
-0.850	*****	0.1200	0.1043	0.0358	-0.6303	-0.6303	-0.6303	-0.6303	-0.6303	-0.6303
-0.900	*****	0.1522	0.1256	0.0516	-0.6357	-0.6357	-0.6357	-0.6357	-0.6357	-0.6357
-0.950	0.2274	0.2000	0.1793	0.1073	-0.2279	-0.2279	-0.2279	-0.2279	-0.2279	-0.2279
-0.975	*****	0.2229	0.2090	0.1518	-0.0734	-0.0734	-0.0734	-0.0734	-0.0734	-0.0734
-1.000	-0.1120	-0.2866	-0.5769	-0.5803	-0.4543	-0.4543	-0.4543	-0.4543	-0.4543	-0.4543

Medium Radius L.E.
 Run No. = 33 , Point No. = 658
 $C_N = 0.202$, $C_m = -0.0340$
 $\alpha = 4.9^\circ$, $M_\infty = 0.869$
 $R_{mac} = 120.5 \times 10^6$

Leading Edge Pressures

● starboard
 ○ port

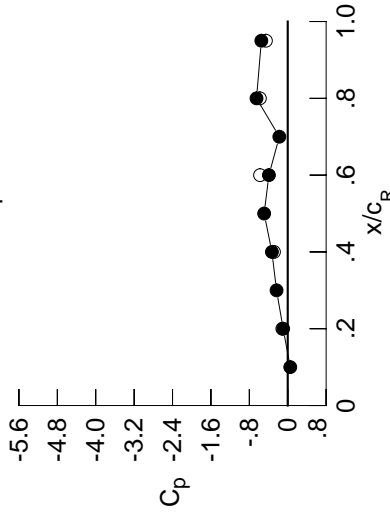

x/c_R	starb'd C_p	port C_p
0.10	0.0531	*****
0.20	-0.0955	-0.1120
0.30	-0.2331	*****
0.40	-0.3296	-0.2866
0.50	-0.4914	*****
0.60	-0.3921	-0.5769
0.70	-0.1752	*****
0.80	-0.6503	-0.5803
0.90	*****	*****
0.95	-0.5493	-0.4543

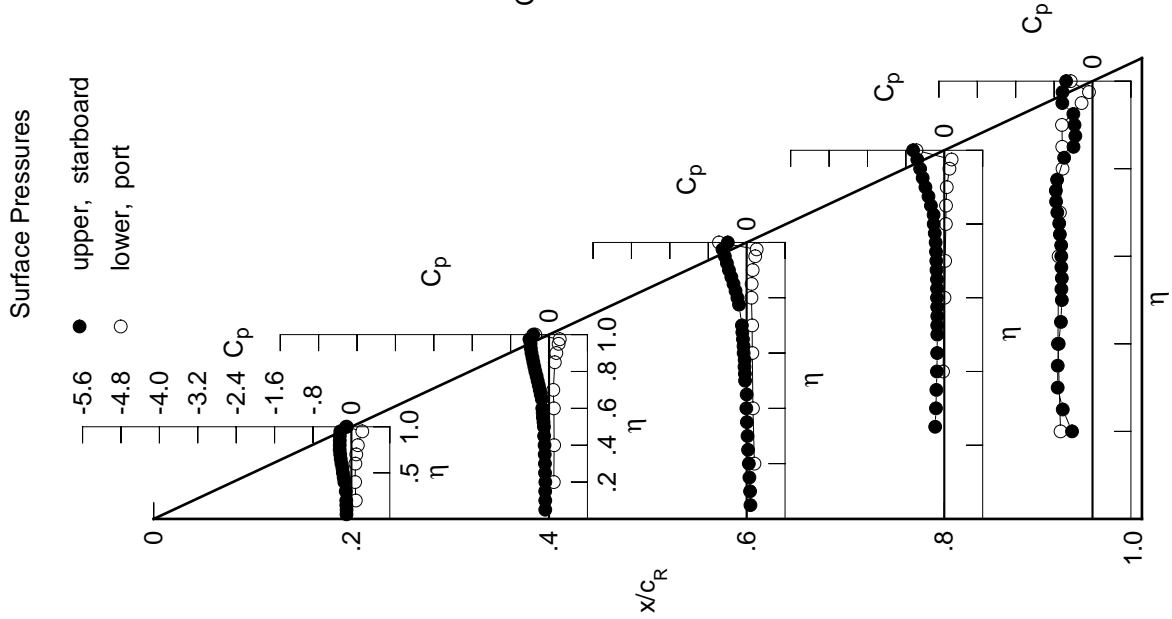

Table H3. Continued.

η	$x/c_R = .2$		$x/c_R = .4$		$x/c_R = .6$		$x/c_R = .8$		$x/c_R = .95$	
	$C_{p,u}$	$C_{p,u}$	$C_{p,u}$	$C_{p,u}$	$C_{p,u}$	$C_{p,u}$	$C_{p,u}$	$C_{p,u}$	$C_{p,u}$	$C_{p,u}$
0.050	-0.1215	-0.0966	0.0665	*****	*****	*****	*****	*****	*****	*****
0.100	-0.1214	-0.0967	0.0582	*****	*****	*****	*****	*****	*****	*****
0.150	-0.1265	-0.0995	0.0442	*****	*****	*****	*****	*****	*****	*****
0.200	-0.1277	-0.0954	0.0317	*****	*****	*****	*****	*****	*****	-0.4478
0.250	*****	-0.1029	0.0157	-0.2033	-0.5818	*****	*****	*****	*****	*****
0.300	-0.1399	-0.1048	0.0038	-0.1878	-0.6757	*****	*****	*****	*****	*****
0.350	*****	-0.1104	-0.0107	-0.1785	-0.6964	*****	*****	*****	*****	*****
0.400	-0.1718	-0.1149	-0.0222	-0.1679	-0.6856	*****	*****	*****	*****	*****
0.450	-0.1872	-0.1253	-0.0172	-0.1636	-0.6451	*****	*****	*****	*****	*****
0.500	-0.2059	-0.1314	-0.0512	-0.1615	-0.6290	*****	*****	*****	*****	*****
0.525	*****	-0.1410	-0.0562	-0.1637	-0.6492	*****	*****	*****	*****	*****
0.550	-0.2185	-0.1543	-0.0646	-0.1615	-0.6473	*****	*****	*****	*****	*****
0.575	*****	-0.1597	-0.0627	-0.1656	-0.6590	*****	*****	*****	*****	*****
0.600	-0.2424	-0.1701	-0.0843	-0.1696	-0.6683	*****	*****	*****	*****	*****
0.625	*****	*****	-0.0877	-0.1700	-0.6851	*****	*****	*****	*****	*****
0.650	-0.2620	-0.1831	-0.1006	-0.1739	-0.7115	*****	*****	*****	*****	*****
0.675	*****	-0.2075	-0.1154	-0.1852	-0.7092	*****	*****	*****	*****	*****
0.700	-0.2776	-0.2311	-0.1269	-0.1919	-0.7179	*****	*****	*****	*****	*****
0.725	*****	-0.2554	*****	-0.2022	-0.7330	*****	*****	*****	*****	*****
0.750	-0.2939	-0.2818	*****	-0.2136	-0.7091	*****	*****	*****	*****	*****
0.775	*****	-0.3090	-0.1972	-0.2361	-0.6229	*****	*****	*****	*****	*****
0.800	-0.3003	-0.3393	-0.2355	-0.2596	*****	*****	*****	*****	*****	*****
0.825	*****	-0.3671	-0.2795	-0.2649	-0.5081	*****	*****	*****	*****	*****
0.850	-0.3060	-0.3958	-0.3293	-0.3202	-0.3601	*****	*****	*****	*****	*****
0.875	*****	-0.4239	-0.3855	-0.3786	-0.3445	*****	*****	*****	*****	*****
0.900	-0.3201	-0.4543	-0.4457	-0.4542	-0.3650	*****	*****	*****	*****	*****
0.925	*****	-0.4836	-0.5038	-0.5339	-0.3732	*****	*****	*****	*****	*****
0.950	-0.3222	-0.5066	-0.5668	-0.6200	-0.6960	*****	*****	*****	*****	*****
0.975	*****	-0.5694	-0.6438	-0.7050	-0.7738	*****	*****	*****	*****	*****
1.000	-0.2535	-0.6088	-0.6291	-0.9411	-0.8242	*****	*****	*****	*****	*****
-0.200	$C_{p,l}$	$C_{p,l}$	$C_{p,l}$	$C_{p,l}$	$C_{p,l}$	$C_{p,l}$	$C_{p,l}$	$C_{p,l}$	$C_{p,l}$	$C_{p,l}$
-0.400	0.1165	0.1201	0.1776	*****	-0.6554	*****	*****	*****	*****	*****
-0.600	0.1030	0.1286	0.1469	-0.0118	-0.7120	*****	*****	*****	*****	*****
-0.700	0.1130	0.1260	0.1375	0.0200	-0.6957	*****	*****	*****	*****	*****
-0.800	0.1330	0.1169	0.1351	0.0355	-0.6676	*****	*****	*****	*****	*****
-0.850	0.1657	*****	0.1260	0.0544	-0.6099	*****	*****	*****	*****	*****
-0.900	*****	0.1529	0.1335	0.0606	-0.6117	*****	*****	*****	*****	*****
-0.950	*****	0.1835	0.1560	0.0807	-0.6067	*****	*****	*****	*****	*****
-0.975	0.2418	0.2205	0.2004	0.1322	-0.2146	*****	*****	*****	*****	*****
-1.000	0.2222	0.2118	0.1608	0.0666	*****	*****	*****	*****	*****	*****
	-0.2655	-0.5317	-0.8182	-0.8693	-0.7400	*****	*****	*****	*****	*****

Medium Radius L.E.
 Run No. = 33 , Point No. = 659
 $C_N = 0.249$, $C_m = -0.0413$
 $\alpha = 6.1^\circ$, $M_\infty = 0.868$
 $R_{mac} = 120.5 \times 10^6$

Leading Edge Pressures

● starboard
 ○ port

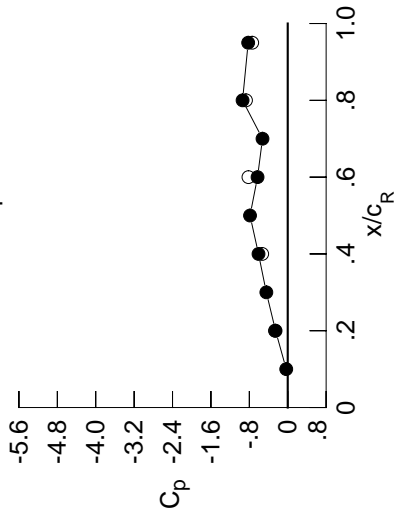

x/c_R	starb'd C_p	port C_p
0.10	-0.0309	*****
0.20	-0.2535	-0.2655
0.30	-0.4460	*****
0.40	-0.6088	-0.5317
0.50	-0.7856	*****
0.60	-0.6291	-0.8182
0.70	-0.5258	*****
0.80	-0.9411	-0.8693
0.90	*****	*****
0.95	-0.8242	-0.7400

Surface Pressures

● upper, starboard
 ○ lower, port

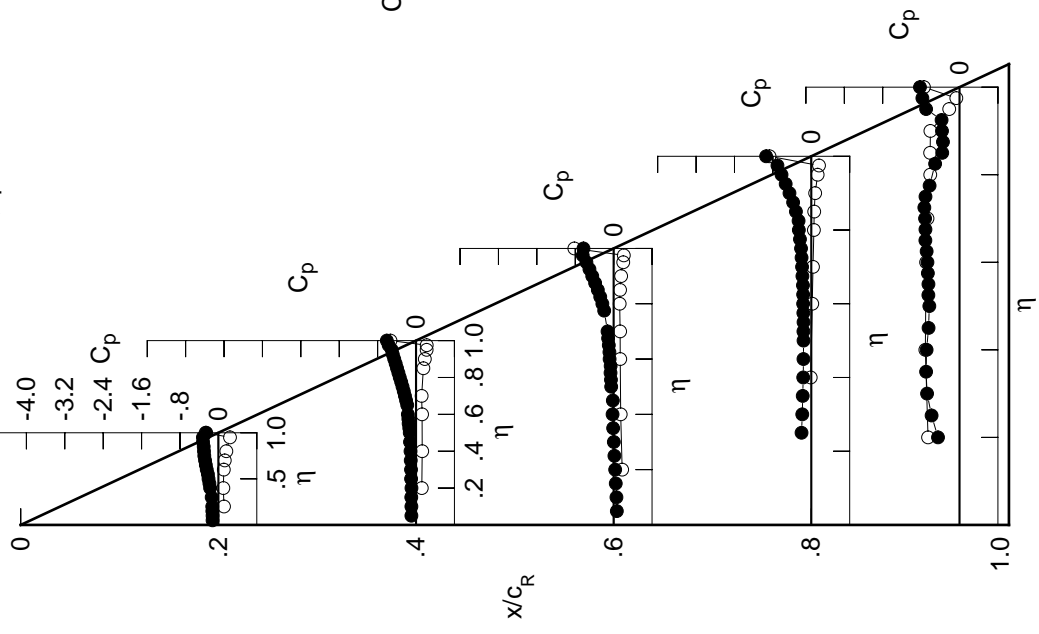
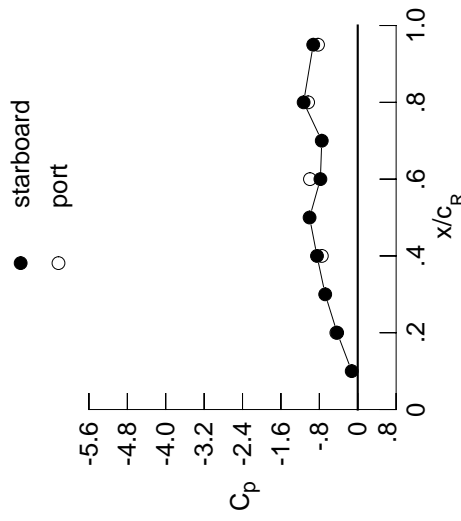

Table H3. Continued.

η	$x/c_R = 0.2$		$x/c_R = 0.4$		$x/c_R = 0.6$		$x/c_R = 0.8$		$x/c_R = 0.95$	
	$C_{p,u}$	$C_{p,l}$	$C_{p,u}$	$C_{p,l}$	$C_{p,u}$	$C_{p,l}$	$C_{p,u}$	$C_{p,l}$	$C_{p,u}$	$C_{p,l}$
0.050	-0.1385	-0.1135	0.0560	*****	*****	*****	*****	*****	*****	*****
0.100	-0.1390	-0.1147	0.0472	*****	*****	*****	*****	*****	*****	*****
0.150	-0.1449	-0.1173	0.0334	*****	*****	*****	*****	*****	*****	*****
0.200	-0.1472	-0.1139	0.0201	*****	*****	*****	*****	*****	-0.4748	*****
0.250	*****	-0.1217	0.0033	-0.2188	-0.5625	*****	*****	*****	*****	*****
0.300	-0.1607	-0.1245	-0.0088	-0.2030	-0.6451	*****	*****	*****	*****	*****
0.350	*****	-0.1311	-0.0238	-0.1944	-0.6520	*****	*****	*****	*****	*****
0.400	-0.1947	-0.1358	-0.0356	-0.1842	-0.6705	*****	*****	*****	*****	*****
0.450	-0.2120	-0.1480	-0.0329	-0.1796	-0.6801	*****	*****	*****	*****	*****
0.500	-0.2329	-0.1548	-0.0675	-0.1781	-0.6607	*****	*****	*****	*****	*****
0.525	*****	-0.1661	-0.0732	-0.1812	-0.6616	*****	*****	*****	*****	*****
0.550	-0.2487	-0.1803	-0.0826	-0.1818	-0.6472	*****	*****	*****	*****	*****
0.575	*****	-0.1869	-0.0823	-0.1869	-0.6479	*****	*****	*****	*****	*****
0.600	-0.2761	-0.1991	-0.1069	-0.1926	-0.6425	*****	*****	*****	*****	*****
0.625	*****	*****	-0.1131	-0.1957	-0.6521	*****	*****	*****	*****	*****
0.650	-0.2999	-0.2144	-0.1295	-0.2033	-0.6802	*****	*****	*****	*****	*****
0.675	*****	-0.2402	-0.1464	-0.2180	-0.6853	*****	*****	*****	*****	*****
0.700	-0.3203	-0.2657	-0.1603	-0.2300	-0.7158	*****	*****	*****	*****	*****
0.725	*****	-0.2928	*****	-0.2463	-0.7321	*****	*****	*****	*****	*****
0.750	-0.3426	-0.3236	*****	-0.2585	-0.7163	*****	*****	*****	*****	*****
0.775	*****	-0.3563	-0.2346	-0.2786	-0.7219	*****	*****	*****	*****	*****
0.800	-0.3553	-0.3921	-0.2724	-0.3056	*****	*****	*****	*****	*****	*****
0.825	*****	-0.4281	-0.3165	-0.3219	-0.6540	*****	*****	*****	*****	*****
0.850	-0.3704	-0.4647	-0.3701	-0.3856	-0.6221	*****	*****	*****	*****	*****
0.875	*****	-0.5040	-0.4329	-0.4130	-0.6921	*****	*****	*****	*****	*****
0.900	-0.3927	-0.5460	-0.5020	-0.4723	-0.6932	*****	*****	*****	*****	*****
0.925	*****	-0.5905	-0.5754	-0.5729	-0.7776	*****	*****	*****	*****	*****
0.950	-0.4224	-0.6308	-0.6638	-0.7314	-0.5947	*****	*****	*****	*****	*****
0.975	*****	-0.7296	-0.9628	-0.9565	-0.6845	*****	*****	*****	*****	*****
1.000	-0.4288	-0.8488	-0.7779	-1.1276	-0.9274	*****	*****	*****	*****	*****
-0.200	$C_{p,l}$	$C_{p,l}$	$C_{p,l}$	$C_{p,l}$	$C_{p,l}$	$C_{p,l}$	$C_{p,l}$	$C_{p,l}$	$C_{p,l}$	$C_{p,l}$
-0.400	0.1420	0.1421	0.1948	*****	*****	*****	*****	*****	-0.6428	*****
-0.600	0.1302	0.1511	0.1650	0.0040	-0.7010	*****	*****	*****	*****	*****
-0.700	0.1428	0.1507	0.1570	0.0377	-0.6811	*****	*****	*****	*****	*****
-0.800	0.1639	0.1444	0.1570	0.0639	-0.6522	*****	*****	*****	*****	*****
-0.850	0.1956	*****	0.1502	0.0752	-0.5923	*****	*****	*****	*****	*****
-0.900	*****	0.1833	0.1599	0.0830	-0.5915	*****	*****	*****	*****	*****
-0.950	*****	0.2109	0.1818	0.1053	-0.5781	*****	*****	*****	*****	*****
-0.975	0.2512	0.2348	0.2160	0.1509	-0.1981	*****	*****	*****	*****	*****
-1.000	*****	0.2147	0.2086	0.1635	-0.0541	*****	*****	*****	*****	*****
	-0.4453	-0.7480	-0.9951	-1.0338	-0.8270	*****	*****	*****	*****	*****

Medium Radius L.E.
 Run No. = 33, Point No. = 660
 $C_N = 0.300$, $C_m = -0.0514$
 $\alpha = 7.1^\circ$, $M_\infty = 0.870$
 $R_{mac} = 120.7 \times 10^6$

Leading Edge Pressures



x/c_R	starb'd C_p	port C_p
0.10	-0.1253	*****
0.20	-0.4288	-0.4453
0.30	-0.6779	*****
0.40	-0.8488	-0.7480
0.50	-1.0030	*****
0.60	-0.7779	-0.9951
0.70	-0.7493	*****
0.80	-1.1276	-1.0338
0.90	*****	*****
0.95	-0.9274	-0.8270

Surface Pressures

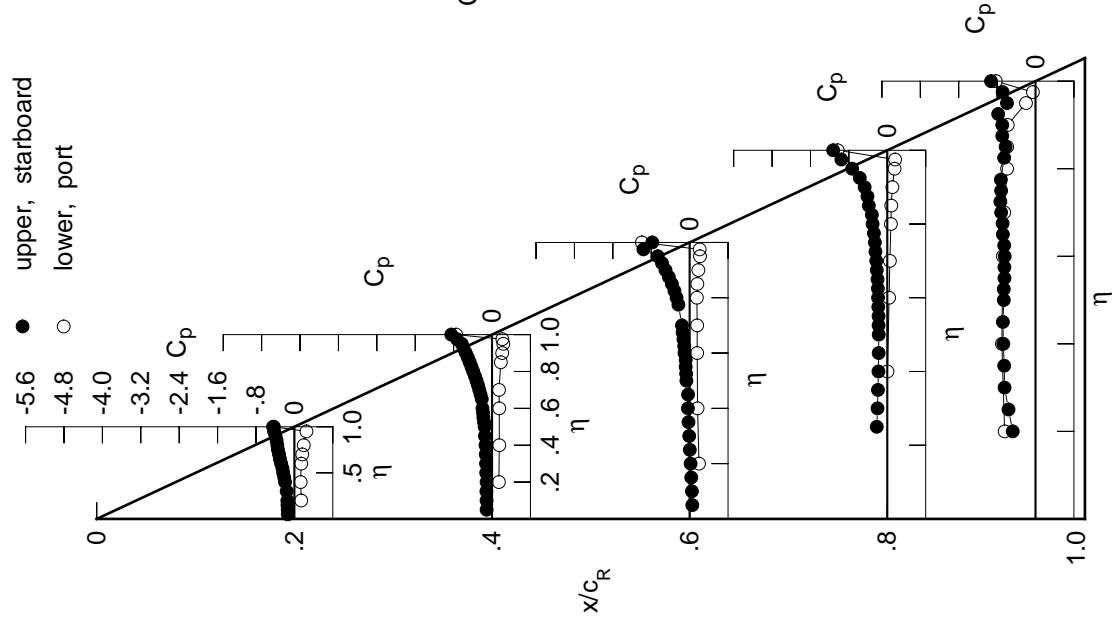
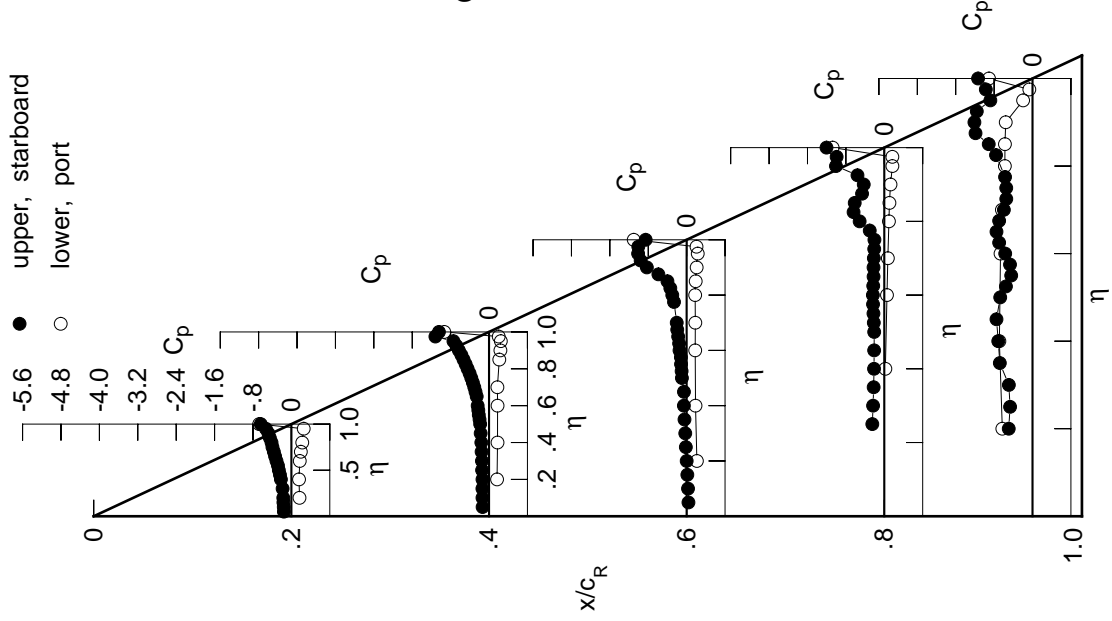

Table H3. Continued.

η	x/c_R .2	x/c_R .4	x/c_R .6	x/c_R .8	x/c_R .95
	$C_{p,u}$	$C_{p,u}$	$C_{p,u}$	$C_{p,u}$	$C_{p,u}$
0.050	-0.1563	-0.1341	0.0379	*****	*****
0.100	-0.1594	-0.1368	0.0287	*****	*****
0.150	-0.1661	-0.1387	0.0143	*****	*****
0.200	-0.1686	-0.1369	0.0007	*****	-0.4953
0.250	*****	-0.1446	-0.0165	-0.2495	-0.4675
0.300	-0.1829	-0.1483	-0.0288	-0.2334	-0.4927
0.350	*****	-0.1551	-0.0444	-0.2217	-0.6809
0.400	-0.2184	-0.1611	-0.0572	-0.2139	-0.7134
0.450	-0.2382	-0.1741	-0.0557	-0.2114	-0.7507
0.500	-0.2615	-0.1845	-0.0984	-0.2102	-0.6727
0.525	*****	-0.1974	-0.1051	-0.2184	-0.5539
0.550	-0.2801	-0.2137	-0.1167	-0.2255	-0.4443
0.575	*****	-0.2230	-0.1196	-0.2347	-0.4691
0.600	-0.3106	-0.2365	-0.1484	-0.2374	-0.5688
0.625	*****	*****	-0.1567	-0.2303	-0.6949
0.650	-0.3388	-0.2569	-0.1770	-0.2235	-0.7507
0.675	*****	-0.2814	-0.1956	-0.2239	-0.6955
0.700	-0.3654	-0.3069	-0.2065	-0.2178	-0.5965
0.725	*****	-0.3366	*****	-0.2100	-0.5464
0.750	-0.3948	-0.3699	*****	-0.2057	-0.5471
0.775	*****	-0.4051	-0.2635	-0.3032	-0.5722
0.800	-0.4139	-0.4464	-0.2996	-0.5132	*****
0.825	*****	-0.4871	-0.3400	-0.6397	-0.7602
0.850	-0.4487	-0.5315	-0.3999	-0.6157	-0.9122
0.875	*****	-0.5760	-0.5885	-0.4635	-1.1869
0.900	-0.4787	-0.6284	-0.8285	-0.4277	-1.2106
0.925	*****	-0.6792	-0.9582	-0.5583	-1.1609
0.950	-0.5320	-0.7412	-1.0112	-1.0061	-0.8781
0.975	*****	-1.1177	-1.0071	-0.9925	-0.9731
1.000	-0.6387	-1.0442	-0.8538	-1.2038	-1.1343
	$C_{p,l}$	$C_{p,l}$	$C_{p,l}$	$C_{p,l}$	$C_{p,l}$
-0.200	0.1690	0.1669	0.2135	*****	-0.6290
-0.400	0.1592	0.1767	0.1851	0.0225	-0.6901
-0.600	0.1746	0.1780	0.1783	0.0563	-0.6668
-0.700	0.1966	0.1741	0.1808	0.0741	-0.6376
-0.800	0.2267	*****	0.1773	0.0967	-0.5761
-0.850	*****	0.2134	0.1886	0.1073	-0.5742
-0.900	*****	0.2365	0.2087	0.1300	-0.5579
-0.950	0.2566	0.2453	0.2308	0.1688	-0.1958
-0.975	*****	0.2018	0.2057	0.1679	-0.0660
-1.000	-0.6709	-0.9323	-1.1022	-1.0762	-0.9063

Surface Pressures



Medium Radius L.E.
 Run No. = 33, Point No. = 661
 $C_N = 0.368$, $C_m = -0.0674$
 $\alpha = 8.3^\circ$, $M_\infty = 0.870$
 $R_{mac} = 120.8 \times 10^6$

Leading Edge Pressures

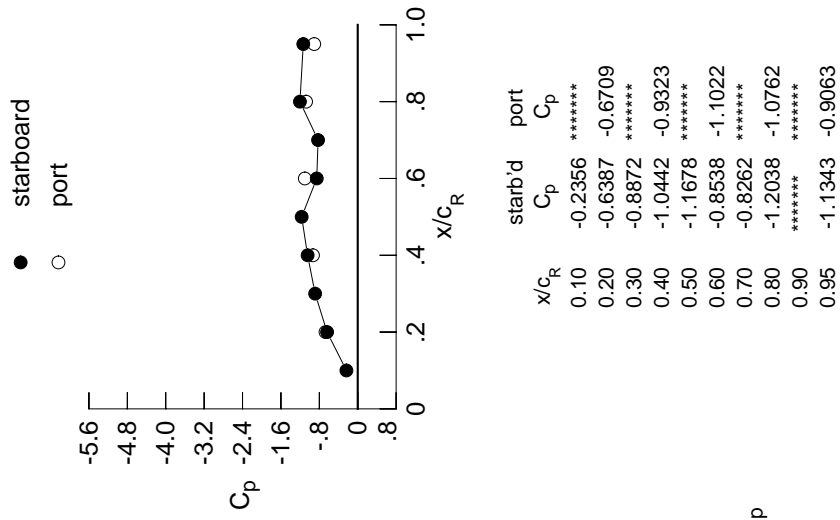
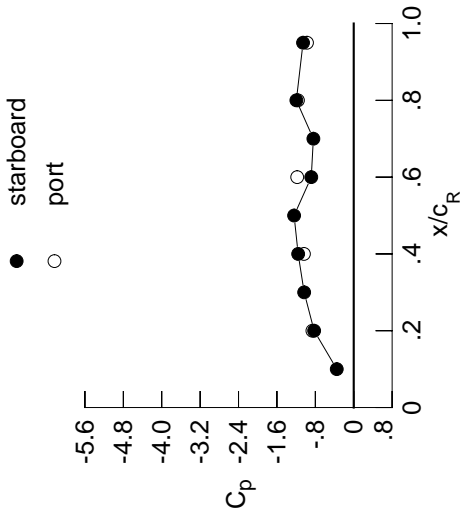

Table H3. Continued.

η	$x/c_R = .2$		$x/c_R = .4$		$x/c_R = .6$		$x/c_R = .8$		$x/c_R = .95$	
	$C_{p,u}$	$C_{p,u}$	$C_{p,u}$	$C_{p,u}$	$C_{p,u}$	$C_{p,u}$	$C_{p,u}$	$C_{p,u}$	$C_{p,u}$	$C_{p,u}$
0.050	-0.1703	-0.1566	0.0191	*****	*****	*****	*****	*****	*****	*****
0.100	-0.1767	-0.1602	0.0098	*****	*****	*****	*****	*****	*****	*****
0.150	-0.1846	-0.1632	-0.0062	*****	*****	*****	*****	*****	*****	*****
0.200	-0.1879	-0.1610	-0.0200	*****	*****	*****	*****	*****	*****	*****
0.250	*****	-0.1702	-0.0376	-0.2818	-0.3276	-0.3686	-0.3686	-0.3686	-0.3686	-0.3686
0.300	-0.2041	-0.1740	-0.0459	-0.2617	-0.5679	-0.5679	-0.5679	-0.5679	-0.5679	-0.5679
0.350	*****	-0.1817	-0.0676	-0.2536	-0.7402	-0.7402	-0.7402	-0.7402	-0.7402	-0.7402
0.400	-0.2423	-0.1882	-0.0836	-0.2461	-0.7349	-0.7349	-0.7349	-0.7349	-0.7349	-0.7349
0.450	-0.2627	-0.2071	-0.0861	-0.2573	-0.4441	-0.4441	-0.4441	-0.4441	-0.4441	-0.4441
0.500	-0.2877	-0.2233	-0.1337	-0.2518	-0.5234	-0.5234	-0.5234	-0.5234	-0.5234	-0.5234
0.525	*****	-0.2381	-0.1491	-0.2449	-0.6747	-0.6747	-0.6747	-0.6747	-0.6747	-0.6747
0.550	-0.3095	-0.2543	-0.1625	-0.2367	-0.7490	-0.7490	-0.7490	-0.7490	-0.7490	-0.7490
0.575	*****	-0.2649	-0.1598	-0.2323	-0.7680	-0.7680	-0.7680	-0.7680	-0.7680	-0.7680
0.600	-0.3437	-0.2799	-0.1734	-0.2305	-0.7640	-0.7640	-0.7640	-0.7640	-0.7640	-0.7640
0.625	*****	*****	-0.1678	-0.2201	-0.7515	-0.7515	-0.7515	-0.7515	-0.7515	-0.7515
0.650	-0.3767	-0.2971	-0.1720	-0.2090	-0.7461	-0.7461	-0.7461	-0.7461	-0.7461	-0.7461
0.675	*****	-0.3224	-0.1784	-0.1995	-0.7397	-0.7397	-0.7397	-0.7397	-0.7397	-0.7397
0.700	-0.4106	-0.3485	-0.1777	-0.1920	-0.8193	-0.8193	-0.8193	-0.8193	-0.8193	-0.8193
0.725	*****	-0.3787	*****	-0.2583	-0.9927	-0.9927	-0.9927	-0.9927	-0.9927	-0.9927
0.750	-0.4513	-0.4120	*****	-0.5353	-1.1250	-1.1250	-1.1250	-1.1250	-1.1250	-1.1250
0.775	*****	-0.4469	-0.1960	-0.8612	-1.1154	-1.1154	-1.1154	-1.1154	-1.1154	-1.1154
0.800	-0.4873	-0.4881	-0.7191	-0.9370	*****	*****	*****	*****	*****	*****
0.825	*****	-0.5248	-0.9802	-0.9704	-0.7652	-0.7652	-0.7652	-0.7652	-0.7652	-0.7652
0.850	-0.5143	-0.5697	-1.0149	-0.9345	-0.7112	-0.7112	-0.7112	-0.7112	-0.7112	-0.7112
0.875	*****	-0.6484	-0.9978	-0.8342	-0.6554	-0.6554	-0.6554	-0.6554	-0.6554	-0.6554
0.900	-0.5674	-0.7952	-0.9564	-0.7230	-0.6546	-0.6546	-0.6546	-0.6546	-0.6546	-0.6546
0.925	*****	-0.9787	-0.9106	-0.6772	-0.6705	-0.6705	-0.6705	-0.6705	-0.6705	-0.6705
0.950	-0.6542	-1.1282	-0.8669	-0.6684	-0.6039	-0.6039	-0.6039	-0.6039	-0.6039	-0.6039
0.975	*****	-1.2399	-0.8515	-0.6382	-0.6489	-0.6489	-0.6489	-0.6489	-0.6489	-0.6489
1.000	-0.8248	-1.1579	-0.8845	-1.1953	-1.0558	-1.0558	-1.0558	-1.0558	-1.0558	-1.0558
	$C_{p,l}$	$C_{p,l}$	$C_{p,l}$	$C_{p,l}$	$C_{p,l}$	$C_{p,l}$	$C_{p,l}$	$C_{p,l}$	$C_{p,l}$	$C_{p,l}$
-0.200	0.1979	0.1921	0.2315	*****	-0.6171	-0.6171	-0.6171	-0.6171	-0.6171	-0.6171
-0.400	0.1895	0.2023	0.2045	0.0384	-0.6808	-0.6808	-0.6808	-0.6808	-0.6808	-0.6808
-0.600	0.2063	0.2053	0.1975	0.0731	-0.6553	-0.6553	-0.6553	-0.6553	-0.6553	-0.6553
-0.700	0.2286	0.2033	0.2028	0.0915	-0.6261	-0.6261	-0.6261	-0.6261	-0.6261	-0.6261
-0.800	0.2556	*****	0.1983	0.1154	-0.5614	-0.5614	-0.5614	-0.5614	-0.5614	-0.5614
-0.850	*****	0.2414	0.2094	0.1269	-0.5590	-0.5590	-0.5590	-0.5590	-0.5590	-0.5590
-0.900	*****	0.2598	0.2260	0.1498	-0.5376	-0.5376	-0.5376	-0.5376	-0.5376	-0.5376
-0.950	0.2584	0.2535	0.2349	0.1796	-0.1886	-0.1886	-0.1886	-0.1886	-0.1886	-0.1886
-0.975	*****	0.1907	0.1923	0.1640	-0.0696	-0.0696	-0.0696	-0.0696	-0.0696	-0.0696
-1.000	-0.8608	-1.0376	-1.1779	-1.1626	-0.9734	-0.9734	-0.9734	-0.9734	-0.9734	-0.9734

Medium Radius L.E.
 Run No. = 33 , Point No. = 662
 $C_N = 0.430$, $C_m = -0.0793$
 $\alpha = 9.3^\circ$, $M_\infty = 0.869$
 $R_{mac} = 120.6 \times 10^6$

Leading Edge Pressures



x/c_R	starb'd C_p	port C_p
0.10	-0.3532	*****
0.20	-0.8248	-0.8608
0.30	-1.0329	*****
0.40	-1.1579	-1.0376
0.50	-1.2425	*****
0.60	-0.8845	-1.1779
0.70	-0.8412	*****
0.80	-1.1953	-1.1626
0.90	*****	*****
0.95	-1.0558	-0.9734

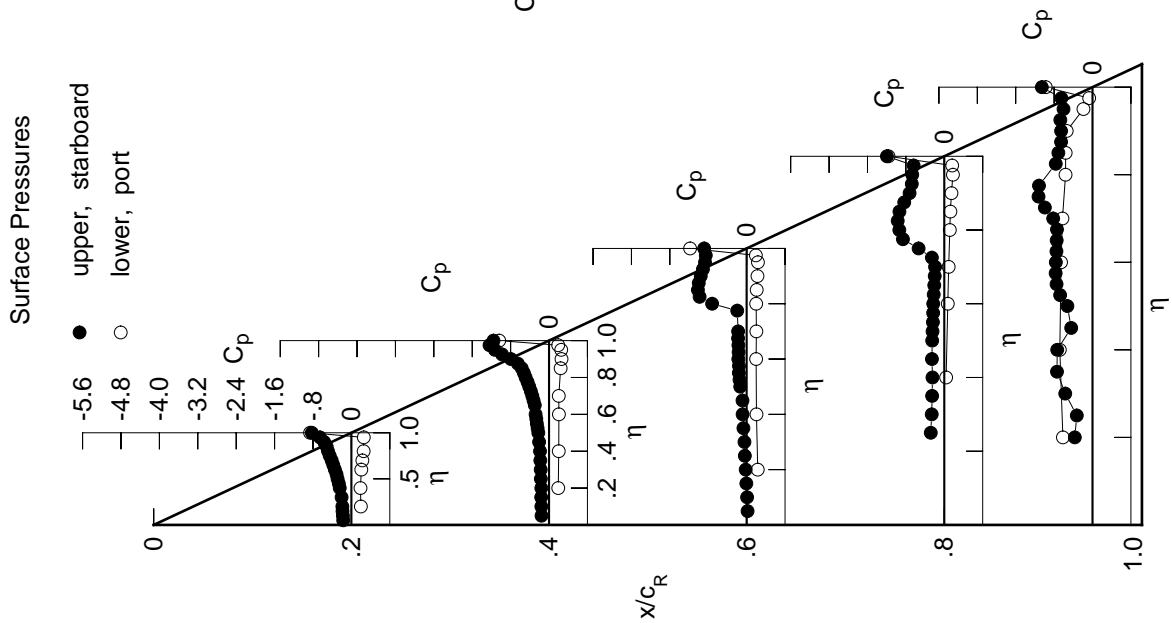
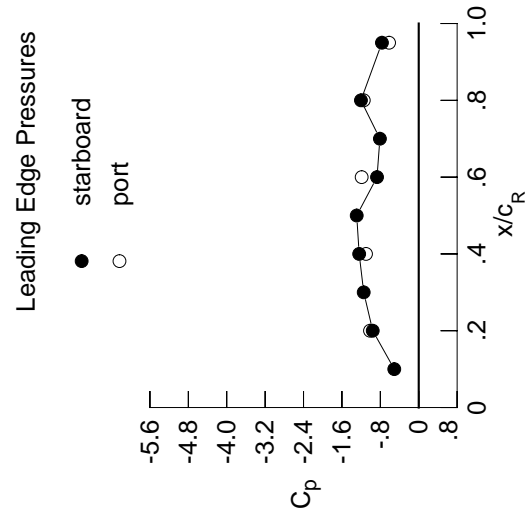

Table H3. Continued.

η	$x/c_R = .2$		$x/c_R = .4$		$x/c_R = .6$		$x/c_R = .8$		$x/c_R = .95$	
	$C_{p,u}$	$C_{p,l}$	$C_{p,u}$	$C_{p,l}$	$C_{p,u}$	$C_{p,l}$	$C_{p,u}$	$C_{p,l}$	$C_{p,u}$	$C_{p,l}$
0.050	-0.1872	-0.1893	-0.0062	*****	*****	*****	*****	*****	*****	*****
0.100	-0.1960	-0.1941	-0.0168	*****	*****	*****	*****	*****	*****	*****
0.150	-0.2058	-0.1973	-0.0331	*****	*****	*****	*****	*****	*****	*****
0.200	-0.2112	-0.1969	-0.0448	*****	*****	*****	*****	*****	*****	*****
0.250	*****	-0.2047	-0.0609	-0.3079	-0.3079	-0.3079	-0.4374	-0.4374	-0.3300	-0.3300
0.300	-0.2283	-0.2075	-0.0793	-0.2910	-0.2910	-0.2910	-0.6523	-0.6523	-0.6523	-0.6523
0.350	*****	-0.2218	-0.0998	-0.2911	-0.2911	-0.2911	-0.6616	-0.6616	-0.6616	-0.6616
0.400	-0.2681	-0.2328	-0.1330	-0.2844	-0.2844	-0.2844	-0.6056	-0.6056	-0.6056	-0.6056
0.450	-0.2907	-0.2575	-0.1312	-0.2658	-0.2658	-0.2658	-0.7223	-0.7223	-0.7223	-0.7223
0.500	-0.3191	-0.2754	-0.1476	-0.2548	-0.2548	-0.2548	-0.7400	-0.7400	-0.7400	-0.7400
0.525	*****	-0.2872	-0.1478	-0.2526	-0.2526	-0.2526	-0.7393	-0.7393	-0.7393	-0.7393
0.550	-0.3448	-0.3028	-0.1532	-0.2438	-0.2438	-0.2438	-0.7285	-0.7285	-0.7285	-0.7285
0.575	*****	-0.3072	-0.1458	-0.2390	-0.2390	-0.2390	-0.7275	-0.7275	-0.7275	-0.7275
0.600	-0.3836	-0.3165	-0.1673	-0.2348	-0.2348	-0.2348	-0.7060	-0.7060	-0.7060	-0.7060
0.625	*****	*****	-0.1601	-0.2289	-0.2289	-0.2289	-0.6974	-0.6974	-0.6974	-0.6974
0.650	-0.4220	-0.3210	-0.1596	-0.2486	-0.2486	-0.2486	-0.7404	-0.7404	-0.7404	-0.7404
0.675	*****	-0.3414	-0.1603	-0.3385	-0.3385	-0.3385	-0.8347	-0.8347	-0.8347	-0.8347
0.700	-0.4697	-0.3551	-0.1802	-0.5349	-0.5349	-0.5349	-0.9872	-0.9872	-0.9872	-0.9872
0.725	*****	-0.3654	*****	-0.7978	-1.1092	-1.1092	-1.1092	-1.1092	-1.1092	-1.1092
0.750	-0.5146	-0.3800	*****	-0.9881	-1.0761	-1.0761	-1.0761	-1.0761	-1.0761	-1.0761
0.775	*****	-0.4988	-1.0778	-1.0868	-1.0796	-1.0796	-1.0796	-1.0796	-1.0796	-1.0796
0.800	-0.5466	-0.7507	-1.0986	-1.0529	*****	*****	*****	*****	*****	*****
0.825	*****	-0.9351	-1.1087	-0.9944	-0.5905	-0.5905	-0.5905	-0.5905	-0.5905	-0.5905
0.850	-0.5906	-1.0351	-1.0702	-0.8193	-0.5432	-0.5432	-0.5432	-0.5432	-0.5432	-0.5432
0.875	*****	-1.0893	-1.0131	-0.7457	-0.5501	-0.5501	-0.5501	-0.5501	-0.5501	-0.5501
0.900	-0.6527	-1.1300	-0.9106	-0.7210	-0.5836	-0.5836	-0.5836	-0.5836	-0.5836	-0.5836
0.925	*****	-1.1248	-0.8260	-0.6721	-0.6277	-0.6277	-0.6277	-0.6277	-0.6277	-0.6277
0.950	-0.8297	-1.1117	-0.7727	-0.6834	-0.5674	-0.5674	-0.5674	-0.5674	-0.5674	-0.5674
0.975	*****	-1.0966	-0.7483	-0.6343	-0.5623	-0.5623	-0.5623	-0.5623	-0.5623	-0.5623
1.000	-0.9581	-1.2409	-0.8691	-1.2042	-0.7666	-0.7666	-0.7666	-0.7666	-0.7666	-0.7666
-0.200	$C_{p,l}$	$C_{p,l}$	$C_{p,l}$	$C_{p,l}$	$C_{p,l}$	$C_{p,l}$	$C_{p,l}$	$C_{p,l}$	$C_{p,l}$	$C_{p,l}$
-0.400	0.2299	0.2205	0.2520	*****	*****	*****	-0.6058	-0.6058	-0.6058	-0.6058
-0.600	0.2230	0.2316	0.2252	0.0552	0.0552	0.0552	-0.6741	-0.6741	-0.6741	-0.6741
-0.700	0.2411	0.2351	0.2204	0.0894	-0.6486	-0.6486	-0.6486	-0.6486	-0.6486	-0.6486
-0.800	0.2624	0.2344	0.2262	0.1086	-0.6192	-0.6192	-0.6192	-0.6192	-0.6192	-0.6192
-0.850	0.2861	*****	0.2233	0.1328	-0.5528	-0.5528	-0.5528	-0.5528	-0.5528	-0.5528
-0.900	*****	0.2708	0.2343	0.1438	-0.5498	-0.5498	-0.5498	-0.5498	-0.5498	-0.5498
-0.950	*****	0.2831	0.2492	0.1653	-0.5223	-0.5223	-0.5223	-0.5223	-0.5223	-0.5223
-0.975	0.2586	0.2625	0.2484	0.1875	-0.1732	-0.1732	-0.1732	-0.1732	-0.1732	-0.1732
-1.000	*****	0.1811	0.1939	0.1612	-0.0465	-0.0465	-0.0465	-0.0465	-0.0465	-0.0465
-1.000	-1.0153	-1.0986	-1.1888	-1.1450	-0.6172	-0.6172	-0.6172	-0.6172	-0.6172	-0.6172

Medium Radius L.E.
 Run No. = 33, Point No. = 663
 $C_N = 0.491$, $C_m = -0.0862$
 $\alpha = 10.4^\circ$, $M_\infty = 0.866$
 $R_{mac} = 120.8 \times 10^6$



x/c_R	starb'd C_p	port C_p
0.10	-0.5097	*****
0.20	-0.9581	-1.0153
0.30	-1.1461	*****
0.40	-1.2409	-1.0986
0.50	-1.2920	*****
0.60	-0.8691	-1.1888
0.70	-0.8091	*****
0.80	-1.2042	-1.1450
0.90	*****	*****
0.95	-0.7666	-0.6172

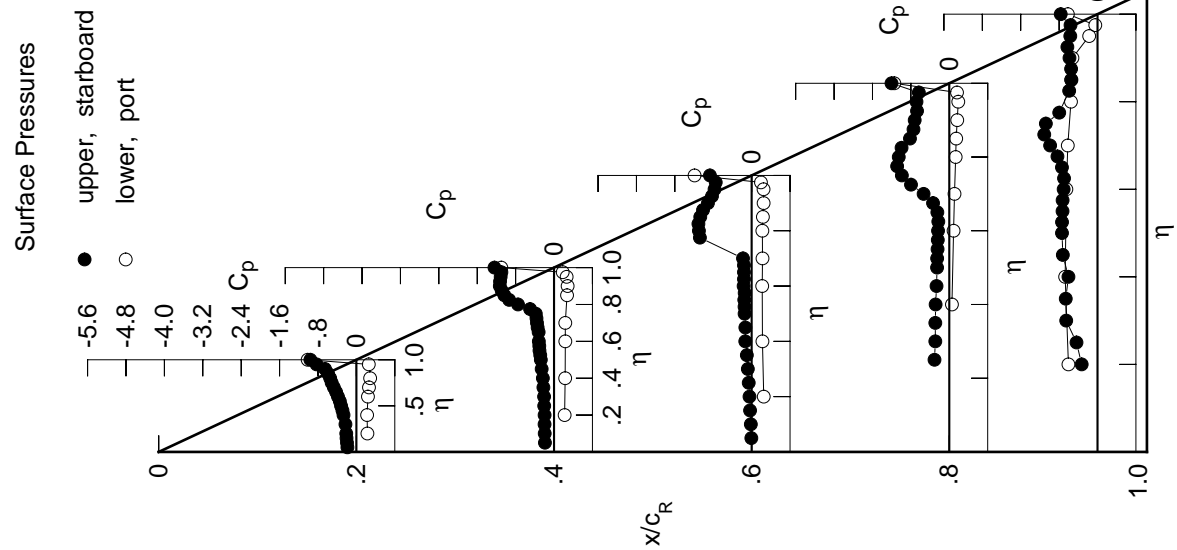
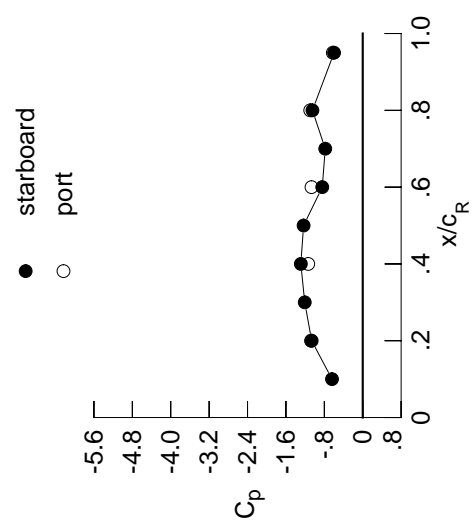

Table H3. Continued.

η	$x/c_R = .2$		$x/c_R = .4$		$x/c_R = .6$		$x/c_R = .8$		$x/c_R = .95$	
	$C_{p,u}$	$C_{p,u}$	$C_{p,u}$	$C_{p,u}$	$C_{p,u}$	$C_{p,u}$	$C_{p,u}$	$C_{p,u}$	$C_{p,u}$	$C_{p,u}$
0.050	-0.2054	-0.2240	-0.0287	*****	*****	*****	*****	*****	*****	*****
0.100	-0.2132	-0.2265	-0.0397	*****	*****	*****	*****	*****	*****	*****
0.150	-0.2282	-0.2318	-0.0561	*****	*****	*****	*****	*****	*****	*****
0.200	-0.2341	-0.2311	-0.0660	*****	*****	*****	*****	*****	*****	-0.4408
0.250	*****	-0.2383	-0.0882	-0.3303	-0.3212	-0.6226	*****	*****	*****	*****
0.300	-0.2553	-0.2470	-0.1104	-0.3212	-0.3112	-0.6231	*****	*****	*****	*****
0.350	*****	-0.2631	-0.1381	-0.3112	-0.3112	-0.6231	*****	*****	*****	*****
0.400	-0.2987	-0.2884	-0.1357	-0.2936	-0.2936	-0.7157	*****	*****	*****	*****
0.450	-0.3226	-0.2967	-0.1161	-0.2830	-0.2830	-0.7193	*****	*****	*****	*****
0.500	-0.3530	-0.2928	-0.1577	-0.2685	-0.2685	-0.6893	*****	*****	*****	*****
0.525	*****	-0.2950	-0.1593	-0.2644	-0.2644	-0.6735	*****	*****	*****	*****
0.550	-0.3794	-0.3026	-0.1574	-0.2566	-0.2566	-0.6539	*****	*****	*****	*****
0.575	*****	-0.2997	-0.1366	-0.2595	-0.2595	-0.6594	*****	*****	*****	*****
0.600	-0.4210	-0.3049	-0.1558	-0.2819	-0.2819	-0.6805	*****	*****	*****	*****
0.625	*****	*****	-0.1570	-0.3405	-0.3405	-0.7617	*****	*****	*****	*****
0.650	-0.4693	-0.3298	-0.2491	-0.4782	-0.4782	-0.9128	*****	*****	*****	*****
0.675	*****	-0.3900	-0.4950	-0.7008	-1.0620	*****	*****	*****	*****	*****
0.700	-0.5108	-0.4650	-0.7902	-0.9161	-1.1928	*****	*****	*****	*****	*****
0.725	*****	-0.6040	*****	-1.0673	-1.2471	*****	*****	*****	*****	*****
0.750	-0.5573	-0.8529	*****	-1.1149	-0.9538	*****	*****	*****	*****	*****
0.775	*****	-1.0414	-1.1009	-1.1079	-0.7506	*****	*****	*****	*****	*****
0.800	-0.5946	-1.1117	-1.0253	-1.0369	*****	*****	*****	*****	*****	*****
0.825	*****	-1.1237	-0.9945	-0.9554	-0.5604	*****	*****	*****	*****	*****
0.850	-0.6353	-1.1183	-0.9552	-0.8219	-0.5151	*****	*****	*****	*****	*****
0.875	*****	-1.1071	-0.9253	-0.7801	-0.5121	*****	*****	*****	*****	*****
0.900	-0.8451	-1.0988	-0.8750	-0.7463	-0.5288	*****	*****	*****	*****	*****
0.925	*****	-1.0707	-0.8296	-0.6869	-0.5662	*****	*****	*****	*****	*****
0.950	-1.1939	-1.0539	-0.7894	-0.6714	-0.5309	*****	*****	*****	*****	*****
0.975	*****	-1.0354	-0.7565	-0.6137	-0.4924	*****	*****	*****	*****	*****
1.000	-1.0637	-1.2895	-0.8429	-1.0477	-0.5978	*****	*****	*****	*****	*****
-0.200	$C_{p,l}$	$C_{p,l}$	$C_{p,l}$	$C_{p,l}$	$C_{p,l}$	$C_{p,l}$	$C_{p,l}$	$C_{p,l}$	$C_{p,l}$	$C_{p,l}$
-0.400	0.2615	0.2466	0.2708	*****	*****	-0.5902	*****	*****	*****	*****
-0.600	0.2558	0.2575	0.2449	0.0708	0.0708	-0.6610	*****	*****	*****	*****
-0.700	0.2745	0.2621	0.2401	0.1047	-0.6356	*****	*****	*****	*****	*****
-0.800	0.2950	0.2626	0.2469	0.1236	-0.6061	*****	*****	*****	*****	*****
-0.850	0.3144	*****	0.2447	0.1481	-0.5388	*****	*****	*****	*****	*****
-0.900	*****	0.2949	0.2550	0.1585	-0.5342	*****	*****	*****	*****	*****
-0.950	*****	0.3010	0.2661	0.1781	-0.5029	*****	*****	*****	*****	*****
-0.975	0.2582	0.2672	0.2542	0.1904	-0.1666	*****	*****	*****	*****	*****
-1.000	*****	0.1687	0.1880	0.1505	-0.0512	*****	*****	*****	*****	*****
	-1.0771	-1.1348	-1.0672	-1.0935	-0.6231	*****	*****	*****	*****	*****

Medium Radius L.E.
 Run No. = 33 , Point No. = 664
 $C_N = 0.559$, $C_m = -0.0978$
 $\alpha = 11.5^\circ$, $M_\infty = 0.869$
 $R_{mac} = 120.0 \times 10^6$

Leading Edge Pressures



x/c_R	starb'd C_p	port C_p
0.10	-0.6397	*****
0.20	-1.0637	-1.0771
0.30	-1.2082	*****
0.40	-1.2895	-1.1348
0.50	-1.2321	*****
0.60	-0.8429	-1.0672
0.70	-0.7809	*****
0.80	-1.0477	-1.0935
0.90	*****	*****
0.95	-0.5978	-0.6231

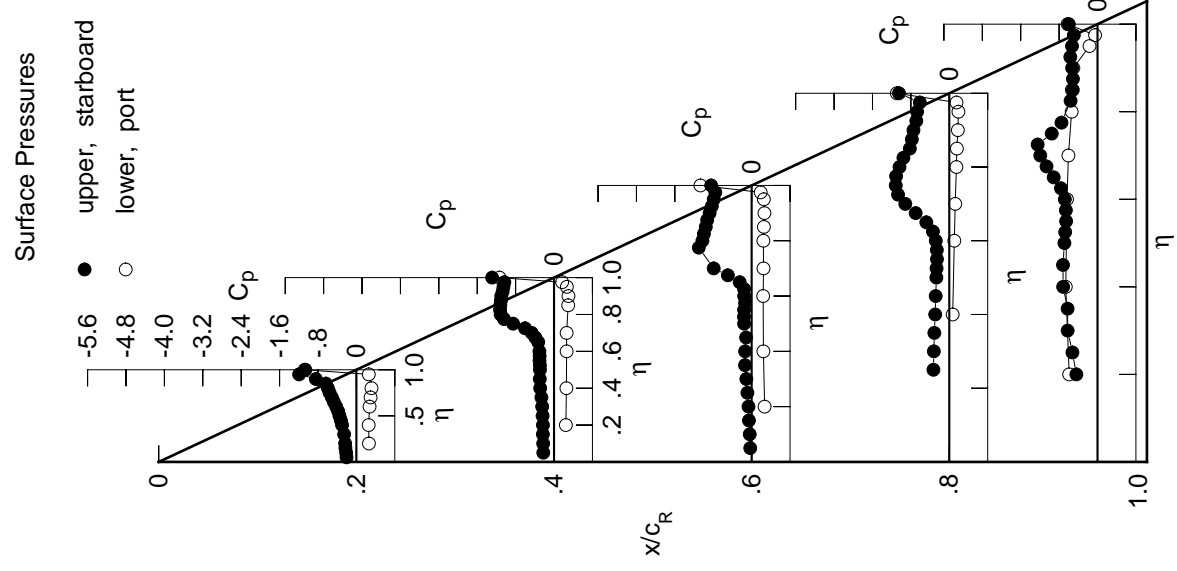
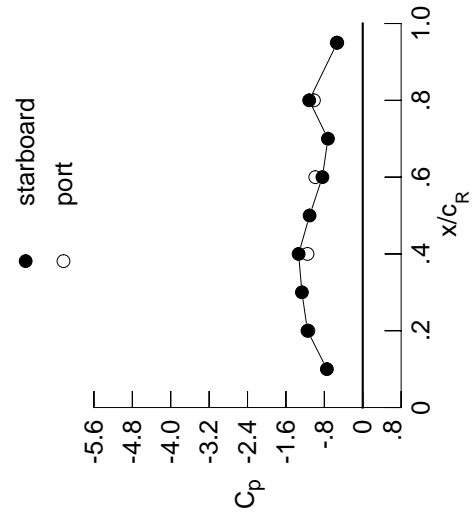

Table H3. Continued.

η	$x/c_R = .2$		$x/c_R = .4$		$x/c_R = .6$		$x/c_R = .8$		$x/c_R = .95$	
	$C_{p,u}$	$C_{p,u}$	$C_{p,u}$	$C_{p,u}$	$C_{p,u}$	$C_{p,u}$	$C_{p,u}$	$C_{p,u}$	$C_{p,u}$	$C_{p,u}$
0.050	-0.2278	-0.2612	-0.0510	*****	*****	*****	*****	*****	*****	*****
0.100	-0.2332	-0.2621	-0.0611	*****	*****	*****	*****	*****	*****	*****
0.150	-0.2527	-0.2663	-0.0755	*****	*****	*****	*****	*****	*****	*****
0.200	-0.2617	-0.2643	-0.0902	*****	*****	*****	*****	*****	*****	*****
0.250	*****	-0.2748	-0.1084	-0.3518	-0.5818	*****	*****	*****	*****	*****
0.300	-0.2889	-0.2874	-0.1357	-0.3449	-0.6382	*****	*****	*****	*****	*****
0.350	*****	-0.3122	-0.1699	-0.3383	-0.6132	*****	*****	*****	*****	*****
0.400	-0.3333	-0.3230	-0.1707	-0.3188	-0.6695	*****	*****	*****	*****	*****
0.450	-0.3545	-0.3597	-0.1501	-0.3066	-0.6860	*****	*****	*****	*****	*****
0.500	-0.3829	-0.3656	-0.1706	-0.2937	-0.6649	*****	*****	*****	*****	*****
0.525	*****	-0.3596	-0.1674	-0.2929	-0.6601	*****	*****	*****	*****	*****
0.550	-0.4116	-0.3688	-0.1666	-0.2925	-0.6607	*****	*****	*****	*****	*****
0.575	*****	-0.3616	-0.1499	-0.3094	-0.6910	*****	*****	*****	*****	*****
0.600	-0.4526	-0.3536	-0.2012	-0.3547	-0.7447	*****	*****	*****	*****	*****
0.625	*****	*****	-0.2665	-0.4481	-0.8495	*****	*****	*****	*****	*****
0.650	-0.4970	-0.3196	-0.4907	-0.6189	-1.0037	*****	*****	*****	*****	*****
0.675	*****	-0.3236	-0.7948	-0.8536	-1.1381	*****	*****	*****	*****	*****
0.700	-0.5377	-0.3837	-1.0259	-1.0708	-0.8155	*****	*****	*****	*****	*****
0.725	*****	-0.7991	*****	-1.2347	-0.7065	*****	*****	*****	*****	*****
0.750	-0.5746	-1.2133	*****	-1.3124	-0.6024	*****	*****	*****	*****	*****
0.775	*****	-1.2929	-1.2499	-1.1013	-0.5466	*****	*****	*****	*****	*****
0.800	-0.6450	-1.2647	-1.1581	-0.9473	*****	*****	*****	*****	*****	*****
0.825	*****	-1.2725	-1.1059	-0.8469	-0.5486	*****	*****	*****	*****	*****
0.850	-0.9557	-1.2417	-1.0441	-0.8100	-0.5163	*****	*****	*****	*****	*****
0.875	*****	-1.2040	-0.9571	-0.8031	-0.5484	*****	*****	*****	*****	*****
0.900	-1.1511	-1.1690	-0.8977	-0.7546	-0.6047	*****	*****	*****	*****	*****
0.925	*****	-1.1290	-0.8593	-0.7121	-0.6242	*****	*****	*****	*****	*****
0.950	-1.2470	-1.0899	-0.8160	-0.7843	-0.5209	*****	*****	*****	*****	*****
0.975	*****	-1.0611	-0.7884	-0.6861	-0.4612	*****	*****	*****	*****	*****
1.000	-1.1509	-1.3358	-0.8400	-1.1155	-0.5315	*****	*****	*****	*****	*****
-0.200	$C_{p,l}$	$C_{p,l}$	$C_{p,l}$	$C_{p,l}$	$C_{p,l}$	$C_{p,l}$	$C_{p,l}$	$C_{p,l}$	$C_{p,l}$	$C_{p,l}$
-0.400	0.2921	0.2718	0.2880	*****	-0.5772	*****	*****	*****	*****	*****
-0.600	0.2870	0.2825	0.2624	0.0861	-0.6517	*****	*****	*****	*****	*****
-0.700	0.3059	0.2876	0.2585	0.1195	-0.6268	*****	*****	*****	*****	*****
-0.800	0.3249	0.2875	0.2655	0.1379	-0.5971	*****	*****	*****	*****	*****
-0.850	0.3402	*****	0.2624	0.1622	-0.5277	*****	*****	*****	*****	*****
-0.900	*****	0.3153	0.2713	0.1728	-0.5221	*****	*****	*****	*****	*****
-0.950	*****	0.3156	0.2782	0.1906	-0.4864	*****	*****	*****	*****	*****
-0.975	0.2558	0.2680	0.2535	0.1931	-0.1587	*****	*****	*****	*****	*****
-1.000	*****	0.1529	0.1727	0.1400	-0.0499	*****	*****	*****	*****	*****
	-1.1318	-1.1505	-0.9883	-1.0169	-0.5407	*****	*****	*****	*****	*****

Medium Radius L.E.
 Run No. = 33, Point No. = 665
 $C_N = 0.618$, $C_m = -0.1055$
 $\alpha = 12.6^\circ$, $M_\infty = 0.869$
 $R_{mac} = 119.9 \times 10^6$

Leading Edge Pressures



x/c_R	starb'd C_p	port C_p
0.10	-0.7470	*****
0.20	-1.1509	-1.1318
0.30	-1.2670	*****
0.40	-1.3358	-1.1505
0.50	-1.1071	*****
0.60	-0.8400	-0.9883
0.70	-0.7250	*****
0.80	-1.1155	-1.0169
0.90	*****	*****
0.95	-0.5315	-0.5407

Surface Pressures

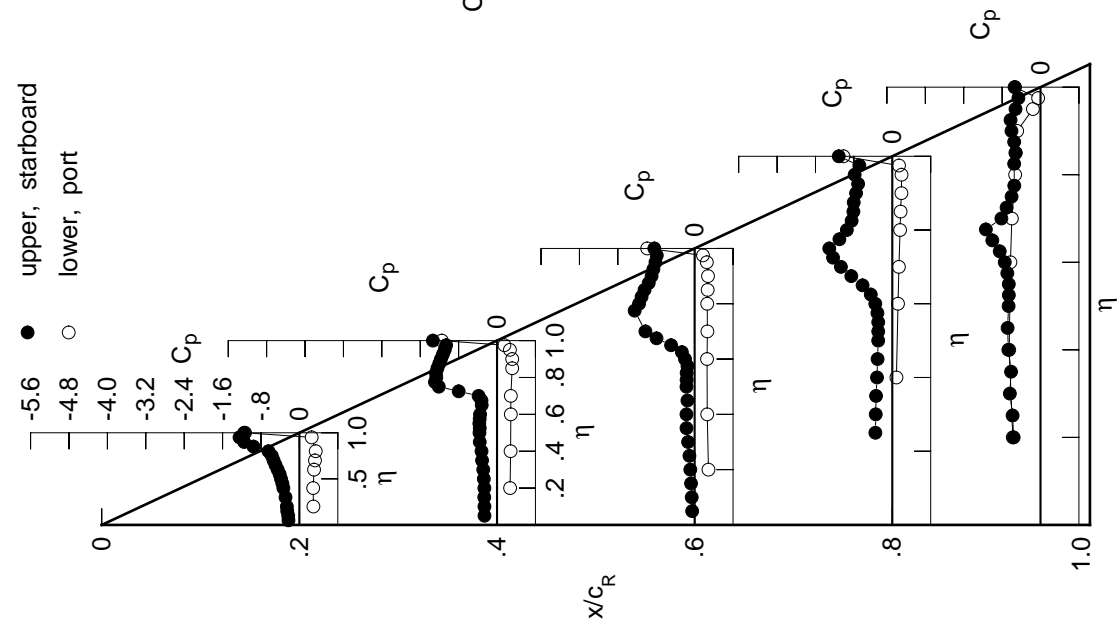

Table H3. Continued.

η	$x/c_R = .2$		$x/c_R = .4$		$x/c_R = .6$		$x/c_R = .8$		$x/c_R = .95$	
	$C_{p,u}$	$C_{p,u}$	$C_{p,u}$	$C_{p,u}$	$C_{p,u}$	$C_{p,u}$	$C_{p,u}$	$C_{p,u}$	$C_{p,u}$	$C_{p,u}$
0.050	-0.2549	-0.2953	-0.0712	*****	*****	*****	*****	*****	*****	*****
0.100	-0.2563	-0.2964	-0.0813	*****	*****	*****	*****	*****	*****	*****
0.150	-0.2758	-0.2953	-0.0978	*****	*****	*****	*****	*****	*****	*****
0.200	-0.2896	-0.2956	-0.1073	*****	*****	*****	*****	*****	*****	*****
0.250	*****	-0.3096	-0.1307	-0.3812	-0.3812	-0.4826	-0.4826	-0.4826	-0.4826	-0.4826
0.300	-0.3328	-0.3337	-0.1492	-0.6238	-0.6238	-0.6238	-0.6238	-0.6238	-0.6238	-0.6238
0.350	*****	-0.3403	-0.1839	-0.3610	-0.3610	-0.6398	-0.6398	-0.6398	-0.6398	-0.6398
0.400	-0.3685	-0.3426	-0.2157	-0.3534	-0.3534	-0.6419	-0.6419	-0.6419	-0.6419	-0.6419
0.450	-0.3837	-0.3787	-0.2074	-0.3475	-0.3475	-0.6406	-0.6406	-0.6406	-0.6406	-0.6406
0.500	-0.4090	-0.4332	-0.2405	-0.3497	-0.3497	-0.6411	-0.6411	-0.6411	-0.6411	-0.6411
0.525	*****	-0.4454	-0.2519	-0.3599	-0.3599	-0.6553	-0.6553	-0.6553	-0.6553	-0.6553
0.550	-0.4363	-0.4451	-0.2754	-0.3847	-0.3847	-0.6840	-0.6840	-0.6840	-0.6840	-0.6840
0.575	*****	-0.4325	-0.3176	-0.4428	-0.4428	-0.7611	-0.7611	-0.7611	-0.7611	-0.7611
0.600	-0.4745	-0.4345	-0.4638	-0.5475	-0.5475	-0.8608	-0.8608	-0.8608	-0.8608	-0.8608
0.625	*****	*****	-0.6137	-0.7009	-0.7009	-0.9952	-0.9952	-0.9952	-0.9952	-0.9952
0.650	-0.5022	-0.4511	-0.8454	-0.8944	-0.8944	-1.1465	-1.1465	-1.1465	-1.1465	-1.1465
0.675	*****	-0.5554	-1.0488	-1.0912	-1.0912	-1.1584	-1.1584	-1.1584	-1.1584	-1.1584
0.700	-0.5260	-0.8118	-1.1693	-1.2436	-1.2436	-0.8481	-0.8481	-0.8481	-0.8481	-0.8481
0.725	*****	-1.1160	*****	-1.2990	-1.2990	-0.7801	-0.7801	-0.7801	-0.7801	-0.7801
0.750	-0.7553	-1.2922	*****	-1.3476	-1.3476	-0.6895	-0.6895	-0.6895	-0.6895	-0.6895
0.775	*****	-1.3214	-1.2390	-1.1231	-1.1231	-0.6180	-0.6180	-0.6180	-0.6180	-0.6180
0.800	-1.0566	-1.2638	-1.1956	-0.9792	-0.9792	*****	*****	*****	*****	*****
0.825	*****	-1.2887	-1.1215	-0.8765	-0.8765	-0.5642	-0.5642	-0.5642	-0.5642	-0.5642
0.850	-1.2008	-1.2530	-1.0360	-0.8287	-0.8287	-0.5191	-0.5191	-0.5191	-0.5191	-0.5191
0.875	*****	-1.2086	-0.9649	-0.8130	-0.8130	-0.5325	-0.5325	-0.5325	-0.5325	-0.5325
0.900	-1.2376	-1.1660	-0.9199	-0.7815	-0.7815	-0.5433	-0.5433	-0.5433	-0.5433	-0.5433
0.925	*****	-1.1234	-0.8784	-0.7166	-0.7166	-0.5421	-0.5421	-0.5421	-0.5421	-0.5421
0.950	-1.2444	-1.0834	-0.8290	-0.7773	-0.7773	-0.4639	-0.4639	-0.4639	-0.4639	-0.4639
0.975	*****	-1.0493	-0.7971	-0.6794	-0.6794	-0.3964	-0.3964	-0.3964	-0.3964	-0.3964
1.000	-1.2186	-1.2917	-0.8293	-1.0398	-1.0398	-0.4386	-0.4386	-0.4386	-0.4386	-0.4386
-0.200	$C_{p,l}$	0.3241	0.2975	0.3069	*****	-0.5644	-0.5644	-0.5644	-0.5644	-0.5644
-0.400	$C_{p,l}$	0.3201	0.3079	0.2817	0.1028	-0.6395	-0.6395	-0.6395	-0.6395	-0.6395
-0.600	$C_{p,l}$	0.3384	0.3133	0.2780	0.1352	-0.6146	-0.6146	-0.6146	-0.6146	-0.6146
-0.700	$C_{p,l}$	0.3554	0.3137	0.2848	0.1540	-0.5843	-0.5843	-0.5843	-0.5843	-0.5843
-0.800	$C_{p,l}$	0.3660	*****	0.2821	0.1776	-0.5140	-0.5140	-0.5140	-0.5140	-0.5140
-0.850	$C_{p,l}$	*****	0.3362	0.2889	0.1881	-0.5066	-0.5066	-0.5066	-0.5066	-0.5066
-0.900	$C_{p,l}$	*****	0.3300	0.2911	0.2032	-0.4664	-0.4664	-0.4664	-0.4664	-0.4664
-0.950	$C_{p,l}$	0.2542	0.2693	0.2532	0.1955	-0.1491	-0.1491	-0.1491	-0.1491	-0.1491
-0.975	$C_{p,l}$	*****	0.1382	0.1575	0.1281	-0.0498	-0.0498	-0.0498	-0.0498	-0.0498
-1.000	$C_{p,l}$	-1.1719	-1.1048	-0.9322	-0.9763	-0.4912	-0.4912	-0.4912	-0.4912	-0.4912

Medium Radius L.E.
 Run No. = 33 , Point No. = 666
 $C_N = 0.682$, $C_m = -0.1151$
 $\alpha = 13.7^\circ$, $M_\infty = 0.869$
 $R_{mac} = 119.9 \times 10^6$

Leading Edge Pressures

● starboard
 ○ port

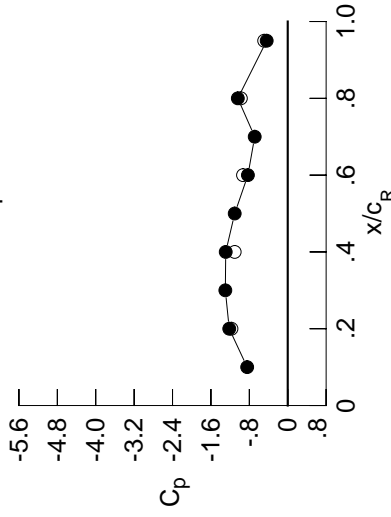

x/c_R	starb'd C_p	port C_p
0.10	-0.8450	*****
0.20	-1.2186	-1.1719
0.30	-1.3000	*****
0.40	-1.2917	-1.1048
0.50	-1.1045	*****
0.60	-0.8293	-0.9322
0.70	-0.6879	*****
0.80	-1.0398	-0.9763
0.90	*****	*****
0.95	-0.4386	-0.4912

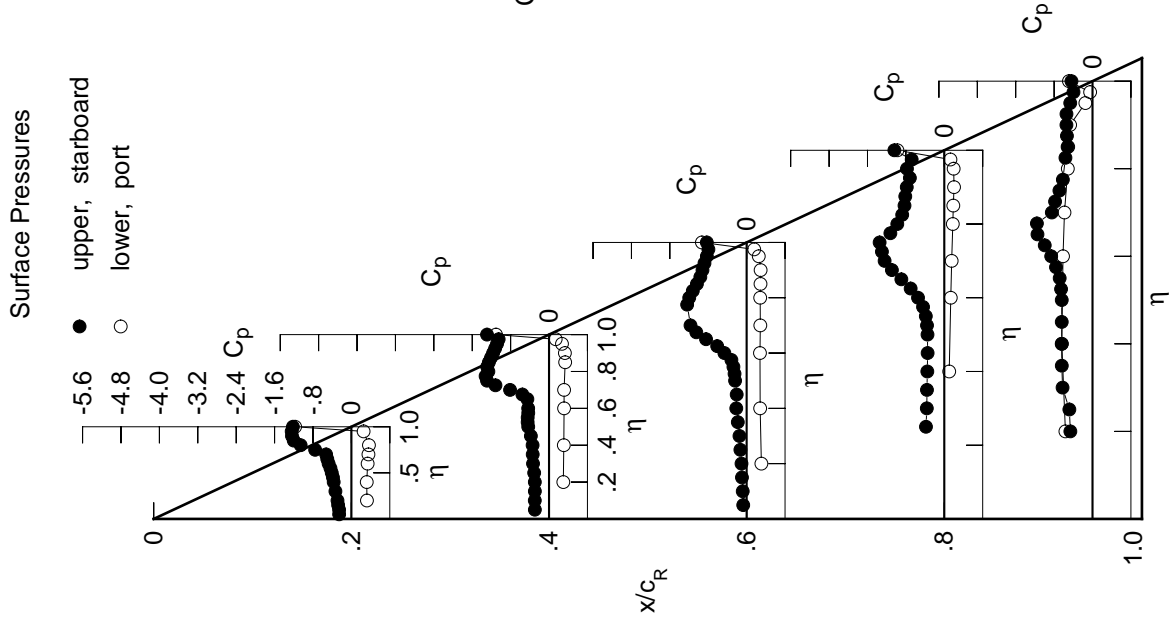

Table H3. Concluded.

η	$x/c_R = .2$		$x/c_R = .4$		$x/c_R = .6$		$x/c_R = .8$		$x/c_R = .95$	
	$C_{p,u}$	$C_{p,u}$	$C_{p,u}$	$C_{p,u}$	$C_{p,u}$	$C_{p,u}$	$C_{p,u}$	$C_{p,u}$	$C_{p,u}$	$C_{p,u}$
0.050	-0.2794	-0.3366	-0.0803	*****	*****	*****	*****	*****	*****	*****
0.100	-0.2766	-0.3385	-0.0908	*****	*****	*****	*****	*****	*****	*****
0.150	-0.2906	-0.3389	-0.1053	*****	*****	*****	*****	*****	*****	*****
0.200	-0.3095	-0.3359	-0.1256	*****	*****	*****	*****	*****	*****	*****
0.250	*****	-0.3742	-0.1501	-0.4123	-0.6328	*****	*****	*****	*****	*****
0.300	-0.3747	-0.3665	-0.1542	-0.3903	-0.5435	*****	*****	*****	*****	*****
0.350	*****	-0.3650	-0.1640	-0.3752	-0.6398	*****	*****	*****	*****	*****
0.400	-0.3813	-0.3638	-0.1723	-0.3588	-0.6825	*****	*****	*****	*****	*****
0.450	-0.3928	-0.3650	-0.1574	-0.3538	-0.6810	*****	*****	*****	*****	*****
0.500	-0.4213	-0.3533	-0.2280	-0.3748	-0.7074	*****	*****	*****	*****	*****
0.525	*****	-0.3608	-0.2818	-0.4126	-0.7437	*****	*****	*****	*****	*****
0.550	-0.4394	-0.3840	-0.3860	-0.4796	-0.7985	*****	*****	*****	*****	*****
0.575	*****	-0.4453	-0.5298	-0.5927	-0.8938	*****	*****	*****	*****	*****
0.600	-0.4497	-0.6067	-0.7922	-0.7487	-0.9959	*****	*****	*****	*****	*****
0.625	*****	*****	-1.0015	-0.9290	-1.1077	*****	*****	*****	*****	*****
0.650	-0.4246	-1.1630	-1.1887	-1.1072	-0.7361	*****	*****	*****	*****	*****
0.675	*****	-1.3392	-1.3265	-1.2615	-0.6359	*****	*****	*****	*****	*****
0.700	-0.8997	-1.3764	-1.3813	-1.2373	-0.5291	*****	*****	*****	*****	*****
0.725	*****	-1.3548	*****	-1.0306	-0.4719	*****	*****	*****	*****	*****
0.750	-1.1810	-1.2929	*****	-1.0012	-0.4463	*****	*****	*****	*****	*****
0.775	*****	-1.2905	-1.1896	-1.0137	-0.4398	*****	*****	*****	*****	*****
0.800	-1.2594	-1.2668	-1.0701	-1.0551	*****	*****	*****	*****	*****	*****
0.825	*****	-1.2268	-1.0020	-1.0484	-0.4775	*****	*****	*****	*****	*****
0.850	-1.2856	-1.1786	-0.9795	-1.0476	-0.4745	*****	*****	*****	*****	*****
0.875	*****	-1.1229	-0.9877	-0.8994	-0.5264	*****	*****	*****	*****	*****
0.900	-1.2599	-1.0824	-0.9545	-0.7904	-0.5702	*****	*****	*****	*****	*****
0.925	*****	-1.0420	-0.8725	-0.7881	-0.5473	*****	*****	*****	*****	*****
0.950	-1.2337	-1.0076	-0.8368	-0.8634	-0.4402	*****	*****	*****	*****	*****
0.975	*****	-0.9890	-0.8074	-0.7404	-0.3622	*****	*****	*****	*****	*****
1.000	-1.2816	-1.1729	-0.8163	-1.0535	-0.3720	*****	*****	*****	*****	*****
-0.200	$C_{p,l}$	$C_{p,l}$	$C_{p,l}$	$C_{p,l}$	$C_{p,l}$	$C_{p,l}$	$C_{p,l}$	$C_{p,l}$	$C_{p,l}$	$C_{p,l}$
-0.400	0.3563	0.3236	0.3255	*****	*****	*****	*****	*****	*****	*****
-0.600	0.3534	0.3343	0.3005	0.1178	-0.6326	*****	*****	*****	*****	*****
-0.700	0.3707	0.3386	0.2967	0.1504	-0.6071	*****	*****	*****	*****	*****
-0.800	0.3853	0.3392	0.3036	0.1693	-0.5753	*****	*****	*****	*****	*****
-0.850	0.3910	*****	0.2992	0.1929	-0.5025	*****	*****	*****	*****	*****
-0.900	*****	0.3557	0.3045	0.2016	-0.4926	*****	*****	*****	*****	*****
-0.950	*****	0.3430	0.3014	0.2141	-0.4482	*****	*****	*****	*****	*****
-0.975	0.2520	0.2689	0.2497	0.1960	-0.1390	*****	*****	*****	*****	*****
-1.000	*****	0.1228	0.1393	0.1173	-0.0471	*****	*****	*****	*****	*****
	-1.2085	-1.0816	-0.9257	-0.9804	-0.4477	*****	*****	*****	*****	*****

Medium Radius L.E.
 Run No. = 33 , Point No. = 667
 $C_N = 0.710$, $C_m = -0.1054$
 $\alpha = 14.7^\circ$, $M_\infty = 0.867$
 $R_{mac} = 119.7 \times 10^6$

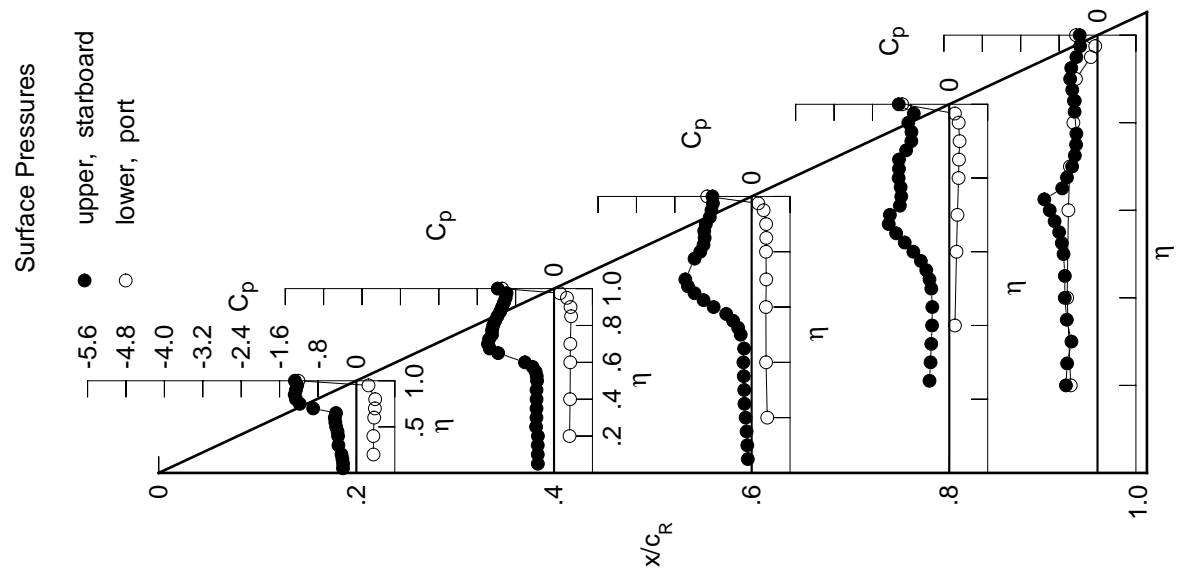
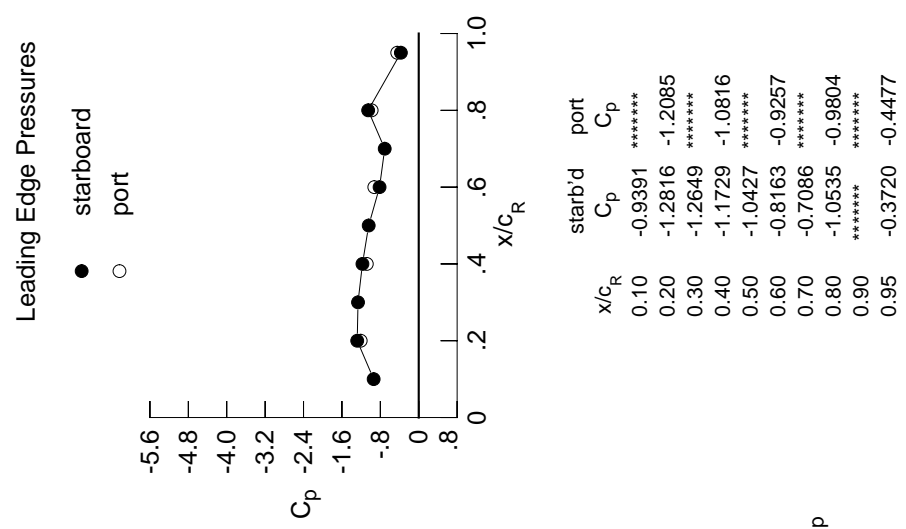
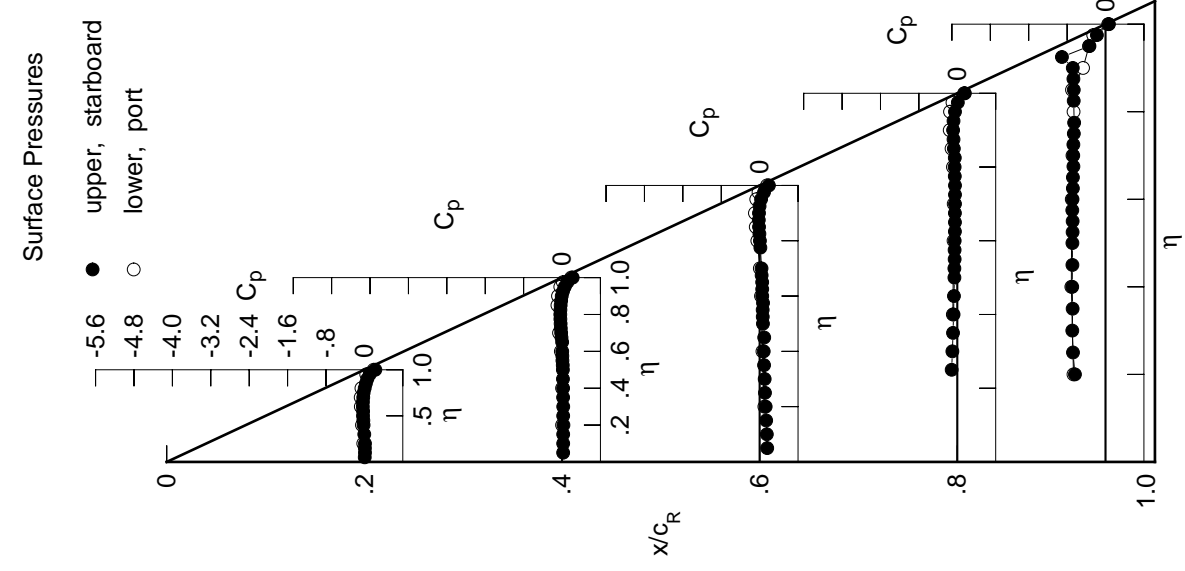

Table H4. Tabulations and Plots of Surface Pressure Coefficients.

η	x/c_R .2	x/c_R .4	x/c_R .6	x/c_R .8	x/c_R .95
	$C_{p,u}$	$C_{p,u}$	$C_{p,u}$	$C_{p,u}$	$C_{p,u}$
0.050	0.0073	0.0235	0.1575	*****	*****
0.100	0.0118	0.0243	0.1500	*****	*****
0.150	0.0100	0.0243	0.1363	*****	*****
0.200	0.0117	0.0287	0.1256	*****	-0.6365
0.250	*****	0.0239	0.1112	-0.1170	-0.6778
0.300	-0.0022	0.0247	-0.1047	-0.1020	-0.6923
0.350	*****	0.0225	0.0924	-0.0889	-0.6851
0.400	-0.0170	0.0223	0.0848	-0.0773	-0.6937
0.450	-0.0216	0.0191	0.0949	-0.0694	-0.6894
0.500	-0.0285	0.0179	0.0688	-0.0601	-0.6900
0.525	*****	0.0151	0.0652	-0.0605	-0.6858
0.550	-0.0265	0.0079	0.0634	-0.0555	-0.6849
0.575	*****	0.0063	0.0700	-0.0556	-0.6916
0.600	-0.0326	0.0043	0.0537	-0.0541	-0.6871
0.625	*****	*****	0.0536	-0.0497	-0.6803
0.650	-0.0304	0.0025	0.0528	-0.0486	-0.6793
0.675	*****	-0.0111	0.0419	-0.0494	-0.6690
0.700	-0.0241	-0.0183	0.0395	-0.0481	-0.6724
0.725	*****	-0.0258	*****	-0.0480	-0.6693
0.750	-0.0161	-0.0295	*****	-0.0482	-0.6601
0.775	*****	-0.0345	0.0155	-0.0518	-0.6537
0.800	0.0064	-0.0363	0.0058	-0.0555	*****
0.825	*****	-0.0335	-0.0047	-0.0519	-0.6621
0.850	0.0306	-0.0292	-0.0129	-0.0723	-0.6615
0.875	*****	-0.0180	-0.0175	-0.0786	-0.6685
0.900	0.0610	-0.0062	-0.0133	-0.0871	-0.6813
0.925	*****	0.0193	-0.0015	-0.0783	-0.9083
0.950	0.1107	0.0569	0.0305	-0.0482	-0.3344
0.975	*****	0.1118	0.0901	0.0110	-0.1795
1.000	0.2282	0.2213	0.1930	0.1573	0.0712
	$C_{p,l}$	$C_{p,l}$	$C_{p,l}$	$C_{p,l}$	$C_{p,l}$
-0.200	-0.0229	0.0012	0.0984	*****	-0.6668
-0.400	-0.0502	0.0010	0.0587	-0.0928	-0.7122
-0.600	-0.0742	-0.0244	0.0278	-0.0775	-0.7030
-0.700	-0.0770	-0.0627	0.0043	-0.0744	-0.6884
-0.800	-0.0613	*****	-0.0479	-0.0904	-0.6653
-0.850	*****	-0.0958	-0.0810	-0.1192	-0.6986
-0.900	*****	-0.0843	-0.0980	-0.1576	-0.4683
-0.950	0.0385	-0.0356	-0.0705	-0.1510	-0.3439
-0.975	*****	0.0175	-0.0235	-0.0997	-0.2560
-1.000	0.1929	0.1910	0.1525	0.1413	0.0557

Medium Radius L.E.
 Run No. = 32, Point No. = 636
 $C_N = -0.032$, $C_m = 0.0049$
 $\alpha = -0.8^\circ$, $M_\infty = 0.899$
 $R_{mac} = 120.4 \times 10^6$



Leading Edge Pressures

● starboard
 ○ port

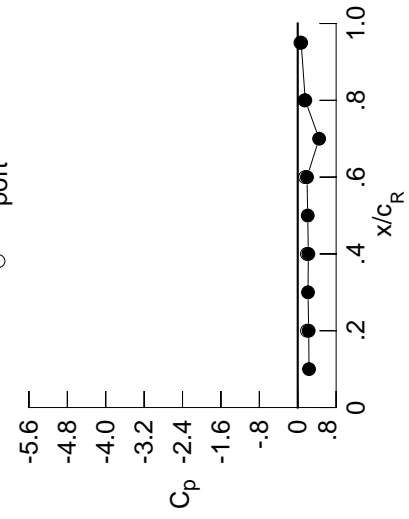

x/c_R	starb'd C_p	port C_p
0.10	0.2354	*****
0.20	0.2282	0.1929
0.30	0.2139	*****
0.40	0.2213	0.1910
0.50	0.2079	*****
0.60	0.1930	0.1525
0.70	0.4456	*****
0.80	0.1573	0.1413
0.90	*****	*****
0.95	0.0712	0.0557

Table H4. Continued.

η	$x/c_R = .2$		$x/c_R = .4$		$x/c_R = .6$		$x/c_R = .8$		$x/c_R = .95$	
	$C_{p,u}$	$C_{p,u}$	$C_{p,u}$	$C_{p,u}$	$C_{p,u}$	$C_{p,u}$	$C_{p,u}$	$C_{p,u}$	$C_{p,u}$	$C_{p,u}$
0.050	-0.0010	0.0173	0.1537	*****	*****	*****	*****	*****	*****	*****
0.100	0.0037	0.0177	0.1463	*****	*****	*****	*****	*****	*****	*****
0.150	0.0024	0.0178	0.1329	*****	*****	*****	*****	*****	*****	*****
0.200	0.0040	0.0217	0.1216	*****	*****	*****	*****	*****	*****	*****
0.250	*****	0.0170	0.1071	-0.1220	-0.6765	*****	*****	*****	*****	*****
0.300	-0.0093	0.0178	0.1003	-0.1073	-0.6913	*****	*****	*****	*****	*****
0.350	*****	0.0150	0.0886	-0.0942	-0.6845	*****	*****	*****	*****	*****
0.400	-0.0250	0.0152	0.0802	-0.0825	-0.6931	*****	*****	*****	*****	*****
0.450	-0.0301	0.0108	0.0904	-0.0745	-0.6886	*****	*****	*****	*****	*****
0.500	-0.0374	0.0102	0.0636	-0.0654	-0.6898	*****	*****	*****	*****	*****
0.525	*****	0.0072	0.0602	-0.0662	-0.6856	*****	*****	*****	*****	*****
0.550	-0.0358	0.0000	0.0581	-0.0612	-0.6849	*****	*****	*****	*****	*****
0.575	*****	-0.0022	0.0644	-0.0612	-0.6918	*****	*****	*****	*****	*****
0.600	-0.0427	-0.0049	0.0481	-0.0603	-0.6871	*****	*****	*****	*****	*****
0.625	*****	*****	0.0472	-0.0561	-0.6807	*****	*****	*****	*****	*****
0.650	-0.0410	-0.0064	0.0469	-0.0548	-0.6804	*****	*****	*****	*****	*****
0.675	*****	-0.0199	0.0348	-0.0561	-0.6699	*****	*****	*****	*****	*****
0.700	-0.0359	-0.0284	0.0329	-0.0548	-0.6735	*****	*****	*****	*****	*****
0.725	*****	-0.0363	*****	-0.0558	-0.6703	*****	*****	*****	*****	*****
0.750	-0.0285	-0.0412	*****	-0.0555	-0.6623	*****	*****	*****	*****	*****
0.775	*****	-0.0465	0.0070	-0.0601	-0.6562	*****	*****	*****	*****	*****
0.800	-0.0070	-0.0500	-0.0049	-0.0647	*****	*****	*****	*****	*****	*****
0.825	*****	-0.0479	-0.0168	-0.0617	-0.6662	*****	*****	*****	*****	*****
0.850	0.0171	-0.0441	-0.0266	-0.0834	-0.6653	*****	*****	*****	*****	*****
0.875	*****	-0.0342	-0.0320	-0.0923	-0.6738	*****	*****	*****	*****	*****
0.900	0.0469	-0.0234	-0.0306	-0.1030	-0.6471	*****	*****	*****	*****	*****
0.925	*****	0.0010	-0.0203	-0.0969	-0.8213	*****	*****	*****	*****	*****
0.950	0.0966	0.0384	0.0101	-0.0685	-0.3436	*****	*****	*****	*****	*****
0.975	*****	0.0931	0.0693	-0.0121	-0.1950	*****	*****	*****	*****	*****
1.000	0.2328	0.2291	0.2121	0.1715	0.0823	*****	*****	*****	*****	*****
-0.200	$C_{p,l}$	$C_{p,l}$	$C_{p,l}$	$C_{p,l}$	$C_{p,l}$	$C_{p,l}$	$C_{p,l}$	$C_{p,l}$	$C_{p,l}$	$C_{p,l}$
-0.400	-0.0168	0.0077	0.1036	*****	-0.6631	*****	*****	*****	*****	*****
-0.600	-0.0418	0.0074	0.0645	-0.0883	-0.7078	*****	*****	*****	*****	*****
-0.700	-0.0635	-0.0160	0.0347	-0.0711	-0.6980	*****	*****	*****	*****	*****
-0.800	-0.0646	-0.0522	0.0130	-0.0678	-0.6826	*****	*****	*****	*****	*****
-0.850	-0.0466	*****	-0.0367	-0.0795	-0.6579	*****	*****	*****	*****	*****
-0.900	*****	-0.0788	-0.0661	-0.1070	-0.6892	*****	*****	*****	*****	*****
-0.950	*****	-0.0647	-0.0787	-0.1399	-0.4805	*****	*****	*****	*****	*****
-0.975	0.0573	-0.0127	-0.0447	-0.1260	-0.3283	*****	*****	*****	*****	*****
-1.000	0.1996	0.0421	0.0047	-0.0702	-0.2331	*****	*****	*****	*****	*****
						0.1996	0.2027	0.1691	0.1622	0.0701

Medium Radius L.E.
 Run No. = 32, Point No. = 637
 $C_N = -0.017$, $C_m = 0.0025$
 $\alpha = -0.4^\circ$, $M_\infty = 0.901$
 $R_{mac} = 120.6 \times 10^6$

Leading Edge Pressures

● starboard
 ○ port

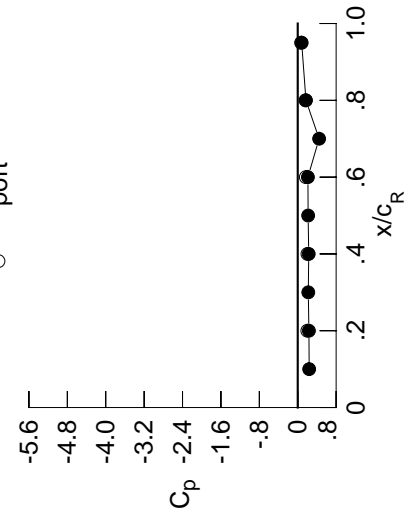

x/c_R	starb'd C_p	port C_p
0.10	0.2386	*****
0.20	0.2328	0.1996
0.30	0.2201	*****
0.40	0.2291	0.2027
0.50	0.2165	*****
0.60	0.2121	0.1691
0.70	0.4453	*****
0.80	0.1715	0.1622
0.90	*****	*****
0.95	0.0823	0.0701

Surface Pressures

● upper, starboard
 ○ lower, port

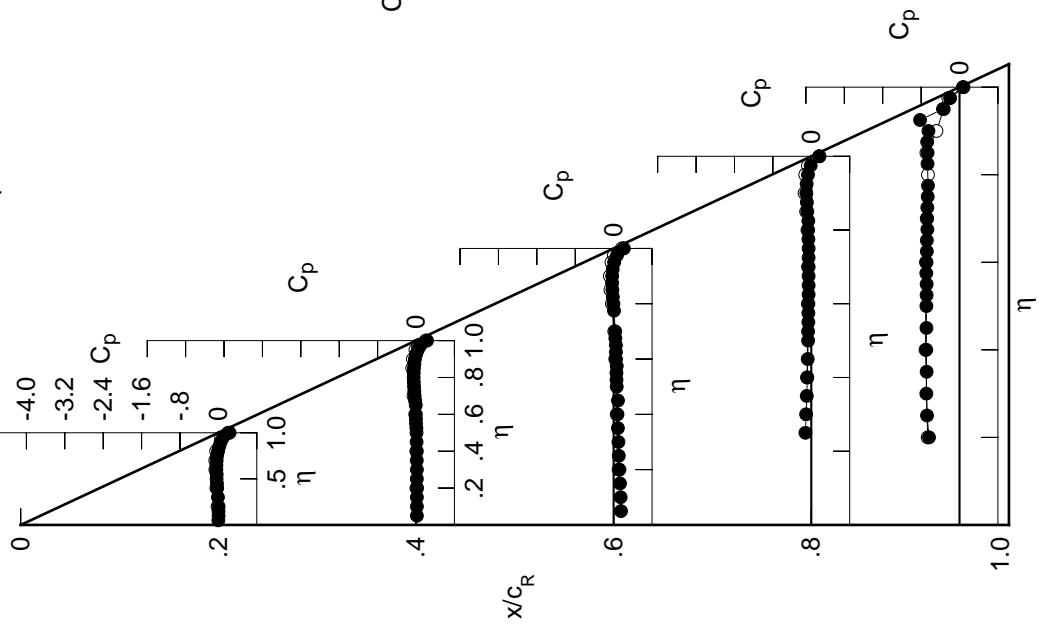
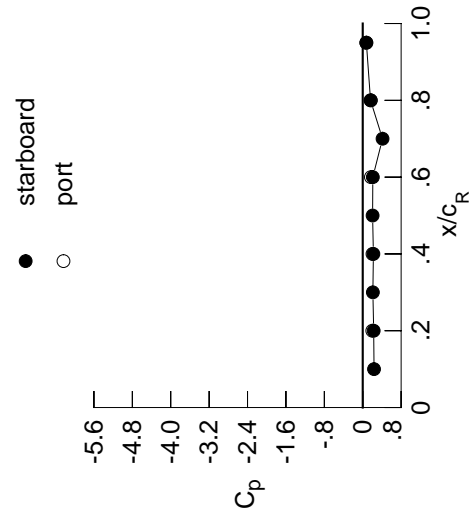

Table H4. Continued.

η	$x/c_R = .2$		$x/c_R = .4$		$x/c_R = .6$		$x/c_R = .8$		$x/c_R = .95$	
	$C_{p,u}$	$C_{p,u}$	$C_{p,u}$	$C_{p,u}$	$C_{p,u}$	$C_{p,u}$	$C_{p,u}$	$C_{p,u}$	$C_{p,u}$	$C_{p,u}$
0.050	-0.0218	-0.0017	0.1412	*****	*****	*****	*****	*****	*****	
0.100	-0.0172	-0.0017	0.1335	*****	*****	*****	*****	*****	*****	
0.150	-0.0179	-0.0009	0.1194	*****	*****	*****	*****	*****	*****	
0.200	-0.0173	0.0024	0.1083	*****	*****	*****	*****	*****	-0.6335	
0.250	*****	-0.0023	0.0940	-0.1367	-0.1367	-0.1367	-0.1367	-0.1367	-0.6801	
0.300	-0.0308	-0.0018	0.0861	-0.1214	-0.1214	-0.1214	-0.1214	-0.1214	-0.6949	
0.350	*****	-0.0055	0.0739	-0.1095	-0.1095	-0.1095	-0.1095	-0.1095	-0.6891	
0.400	-0.0493	-0.0053	0.0652	-0.0968	-0.0968	-0.0968	-0.0968	-0.0968	-0.6977	
0.450	-0.0557	-0.0104	0.0744	-0.0900	-0.0900	-0.0900	-0.0900	-0.0900	-0.6944	
0.500	-0.0642	-0.0120	0.0472	-0.0810	-0.0810	-0.0810	-0.0810	-0.0810	-0.6964	
0.525	*****	-0.0163	0.0427	-0.0822	-0.0822	-0.0822	-0.0822	-0.0822	-0.6920	
0.550	-0.0652	-0.0240	0.0405	-0.0776	-0.0776	-0.0776	-0.0776	-0.0776	-0.6923	
0.575	*****	-0.0269	0.0455	-0.0781	-0.0781	-0.0781	-0.0781	-0.0781	-0.6991	
0.600	-0.0737	-0.0311	0.0288	-0.0778	-0.0778	-0.0778	-0.0778	-0.0778	-0.6952	
0.625	*****	*****	0.0272	-0.0740	-0.0740	-0.0740	-0.0740	-0.0740	-0.6883	
0.650	-0.0748	-0.0338	0.0258	-0.0736	-0.0736	-0.0736	-0.0736	-0.0736	-0.6889	
0.675	*****	-0.0490	0.0129	-0.0763	-0.0763	-0.0763	-0.0763	-0.0763	-0.6785	
0.700	-0.0722	-0.0594	0.0092	-0.0754	-0.0754	-0.0754	-0.0754	-0.0754	-0.6831	
0.725	*****	-0.0696	*****	-0.0772	-0.0772	-0.0772	-0.0772	-0.0772	-0.6811	
0.750	-0.0668	-0.0770	*****	-0.0791	-0.0791	-0.0791	-0.0791	-0.0791	-0.6736	
0.775	*****	-0.0856	-0.0228	-0.0856	-0.0856	-0.0856	-0.0856	-0.0856	-0.6701	
0.800	-0.0479	-0.0914	-0.0374	-0.0930	-0.0930	-0.0930	-0.0930	-0.0930	*****	
0.825	*****	-0.0935	-0.0543	-0.0911	-0.0911	-0.0911	-0.0911	-0.0911	-0.6834	
0.850	-0.0262	-0.0926	-0.0688	-0.1194	-0.1194	-0.1194	-0.1194	-0.1194	-0.6782	
0.875	*****	-0.0876	-0.0813	-0.1344	-0.1344	-0.1344	-0.1344	-0.1344	-0.6926	
0.900	0.0007	-0.0794	-0.0853	-0.1532	-0.1532	-0.1532	-0.1532	-0.1532	-0.4907	
0.925	*****	-0.0600	-0.0817	-0.1554	-0.1554	-0.1554	-0.1554	-0.1554	-0.6554	
0.950	0.0489	-0.0254	-0.0585	-0.1372	-0.1372	-0.1372	-0.1372	-0.1372	-0.3815	
0.975	*****	0.0238	-0.0060	-0.0886	-0.0886	-0.0886	-0.0886	-0.0886	-0.2526	
1.000	0.2283	0.2220	0.2102	0.1625	0.1625	0.1625	0.1625	0.1625	0.0759	
	$C_{p,l}$	$C_{p,l}$	$C_{p,l}$	$C_{p,l}$	$C_{p,l}$	$C_{p,l}$	$C_{p,l}$	$C_{p,l}$	$C_{p,l}$	
-0.200	0.0058	0.0264	0.1168	*****	*****	*****	*****	*****	-0.6568	
-0.400	-0.0177	0.0287	0.0799	-0.0724	-0.0724	-0.0724	-0.0724	-0.0724	-0.7013	
-0.600	-0.0320	0.0093	0.0537	-0.0529	-0.0529	-0.0529	-0.0529	-0.0529	-0.6898	
-0.700	-0.0282	-0.0204	0.0370	-0.0467	-0.0467	-0.0467	-0.0467	-0.0467	-0.6727	
-0.800	-0.0049	*****	-0.0034	-0.0523	-0.0523	-0.0523	-0.0523	-0.0523	-0.6426	
-0.850	*****	-0.0307	-0.0235	-0.0710	-0.0710	-0.0710	-0.0710	-0.0710	-0.6674	
-0.900	*****	-0.0089	-0.0242	-0.0898	-0.0898	-0.0898	-0.0898	-0.0898	-0.5543	
-0.950	0.1064	0.0492	0.0224	-0.0585	-0.0585	-0.0585	-0.0585	-0.0585	-0.2910	
-0.975	*****	0.1047	0.0787	0.0058	0.0058	0.0058	0.0058	0.0058	-0.1769	
-1.000	0.1993	0.2030	0.1705	0.1697	0.1697	0.1697	0.1697	0.1697	0.0747	

Medium Radius L.E.
 Run No. = 32, Point No. = 638
 $C_N = 0.028$, $C_m = -0.0059$
 $\alpha = 0.6^\circ$, $M_\infty = 0.901$
 $R_{mac} = 120.4 \times 10^6$

Leading Edge Pressures



x/c_R	starb'd C_p	port C_p
0.10	0.2356	*****
0.20	0.2283	0.1993
0.30	0.2115	*****
0.40	0.2220	0.2030
0.50	0.2057	*****
0.60	0.2102	0.1705
0.70	0.4124	*****
0.80	0.1625	0.1697
0.90	*****	*****
0.95	0.0759	0.0747

Surface Pressures

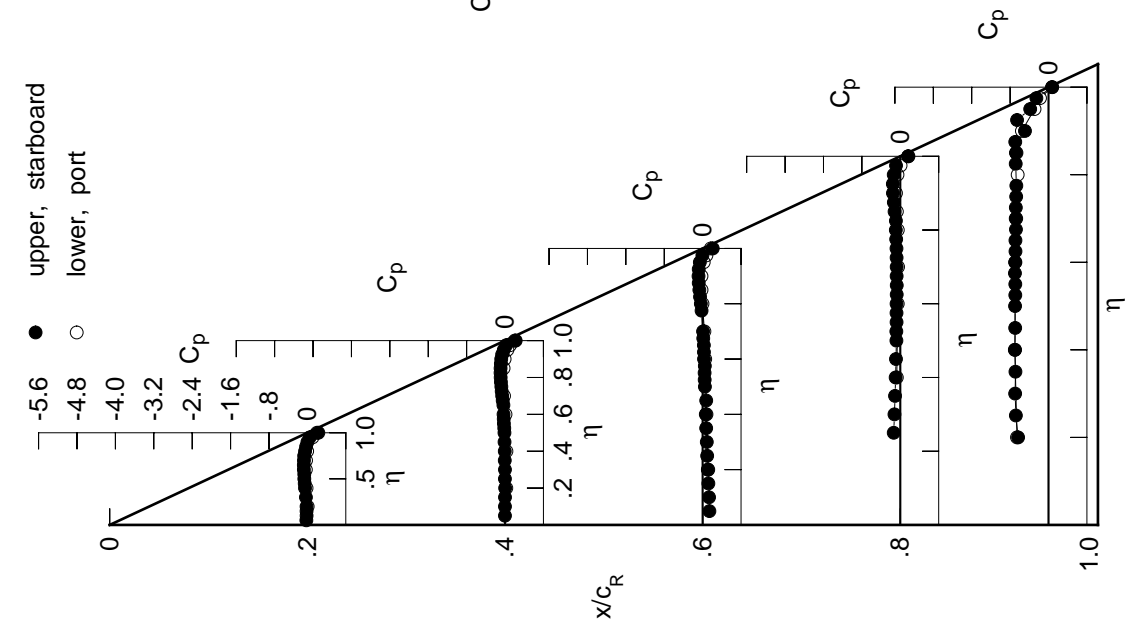

Table H4. Continued.

η	x/c_R .2	x/c_R .4	x/c_R .6	x/c_R .8	x/c_R .95
	$C_{p,u}$	$C_{p,u}$	$C_{p,u}$	$C_{p,u}$	$C_{p,u}$
0.050	-0.0426	-0.0217	0.1269	0.1269	0.1269
0.100	-0.0385	-0.0210	0.1195	0.1195	0.1195
0.150	-0.0399	-0.0208	0.1050	0.1050	0.1050
0.200	-0.0390	-0.0182	0.0945	0.0945	0.0945
0.250	*****	-0.0227	0.0784	-0.1518	-0.6875
0.300	-0.0530	-0.0232	0.0712	-0.1371	-0.7030
0.350	*****	-0.0264	0.0580	-0.1245	-0.6975
0.400	-0.0739	-0.0277	0.0489	-0.1130	-0.7075
0.450	-0.0822	-0.0326	0.0568	-0.1059	-0.7041
0.500	-0.0924	-0.0364	0.0284	-0.0987	-0.7073
0.525	*****	-0.0405	0.0243	-0.0997	-0.7037
0.550	-0.0960	-0.0497	0.0209	-0.0960	-0.7035
0.575	*****	-0.0537	0.0260	-0.0967	-0.7113
0.600	-0.1066	-0.0585	0.0076	-0.0965	-0.7067
0.625	*****	*****	0.0060	-0.0943	-0.7016
0.650	-0.1109	-0.0629	0.0026	-0.0947	-0.7010
0.675	*****	-0.0801	-0.0108	-0.0974	-0.6922
0.700	-0.1111	-0.0933	-0.0160	-0.0983	-0.6970
0.725	*****	-0.1056	*****	-0.1013	-0.6961
0.750	-0.1091	-0.1161	*****	-0.1048	-0.6898
0.775	*****	-0.1280	-0.0553	-0.1138	-0.6878
0.800	-0.0936	-0.1385	-0.0744	-0.1236	*****
0.825	*****	-0.1438	-0.0960	-0.1235	-0.6996
0.850	-0.0751	-0.1479	-0.1174	-0.1587	-0.6971
0.875	*****	-0.1469	-0.1358	-0.1810	-0.5968
0.900	-0.0528	-0.1439	-0.1491	-0.2097	-0.4461
0.925	*****	-0.1301	-0.1536	-0.2227	-0.5598
0.950	-0.0090	-0.1012	-0.1406	-0.2171	-0.4300
0.975	*****	-0.0612	-0.1016	-0.1842	-0.3273
1.000	0.1960	0.1625	0.1290	0.0704	0.0072
	$C_{p,l}$	$C_{p,l}$	$C_{p,l}$	$C_{p,l}$	$C_{p,l}$
-0.200	0.0264	0.0459	0.1296	0.1296	0.1296
-0.400	0.0070	0.0484	0.0946	-0.0578	-0.6990
-0.600	-0.0013	0.0339	0.0727	-0.0362	-0.6852
-0.700	0.0070	0.0099	0.0592	-0.0266	-0.6665
-0.800	0.0345	*****	0.0270	-0.0271	-0.6310
-0.850	*****	0.0139	0.0156	-0.0387	-0.6496
-0.900	*****	0.0415	0.0241	-0.0454	-0.6943
-0.950	0.1478	0.1018	0.0784	-0.0017	-0.2630
-0.975	*****	0.1560	0.1355	0.0645	-0.1339
-1.000	0.1681	0.1522	0.0948	0.0938	0.0211

Medium Radius L.E.
 Run No. = 32, Point No. = 639
 $C_N = 0.073$, $C_m = -0.0131$
 $\alpha = 1.7^\circ$, $M_\infty = 0.899$
 $R_{mac} = 120.5 \times 10^6$

Leading Edge Pressures

● starboard
 ○ port

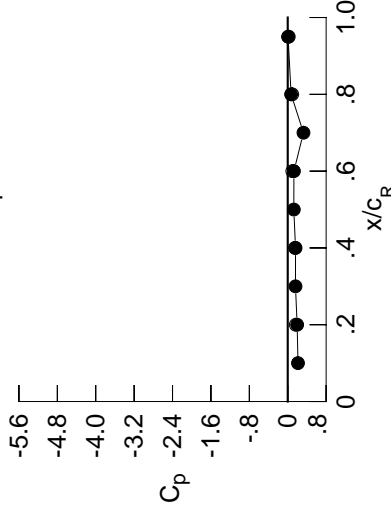

x/c_R	starb'd C_p	port C_p
0.10	0.2139	*****
0.20	0.1960	0.1681
0.30	0.1613	*****
0.40	0.1625	0.1522
0.50	0.1264	*****
0.60	0.1290	0.0948
0.70	0.3278	*****
0.80	0.0704	0.0938
0.90	*****	*****
0.95	0.0072	0.0211

Surface Pressures

● upper, starboard
 ○ lower, port

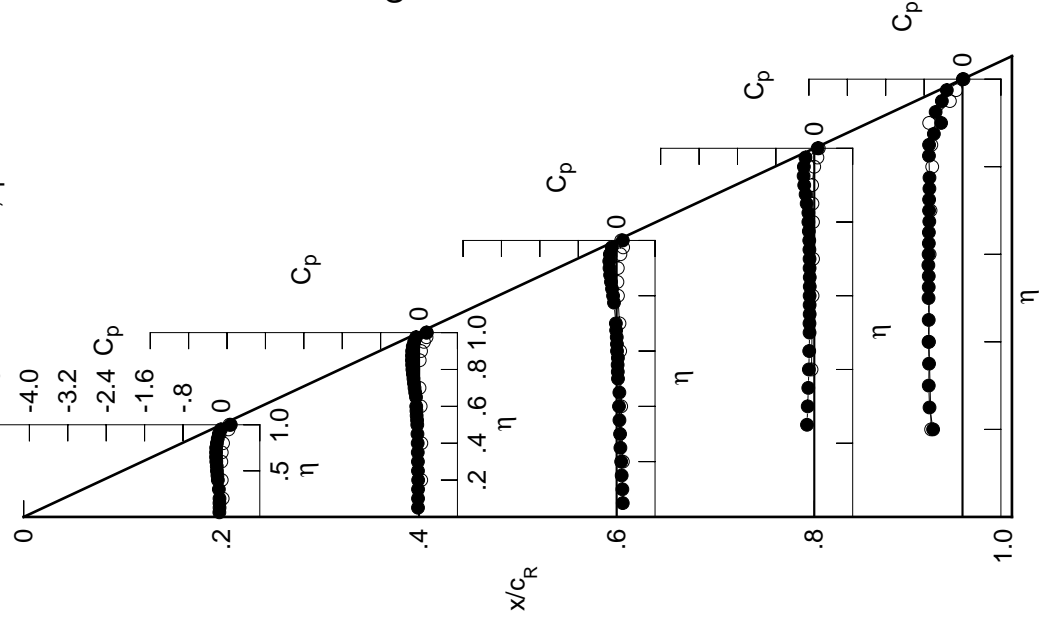

Table H4. Continued.

η	$x/c_R = .2$		$x/c_R = .4$		$x/c_R = .6$		$x/c_R = .8$		$x/c_R = .95$	
	$C_{p,u}$	$C_{p,u}$	$C_{p,u}$	$C_{p,u}$	$C_{p,u}$	$C_{p,u}$	$C_{p,u}$	$C_{p,u}$	$C_{p,u}$	$C_{p,u}$
0.050	-0.0620	-0.0388	0.1166	*****	*****	*****	*****	*****	*****	
0.100	-0.0584	-0.0393	0.1082	*****	*****	*****	*****	*****	*****	
0.150	-0.0589	-0.0392	0.0945	*****	*****	*****	*****	*****	*****	
0.200	-0.0594	-0.0359	0.0825	*****	*****	*****	*****	*****	-0.5830	
0.250	*****	-0.0408	0.0673	-0.1667	-0.1667	-0.1667	-0.1667	-0.1667	-0.6876	
0.300	-0.0733	-0.0417	0.0583	-0.1518	-0.1518	-0.1518	-0.1518	-0.1518	-0.7041	
0.350	*****	-0.0460	0.0457	-0.1403	-0.1403	-0.1403	-0.1403	-0.1403	-0.6971	
0.400	-0.0971	-0.0475	0.0355	-0.1280	-0.1280	-0.1280	-0.1280	-0.1280	-0.7119	
0.450	-0.1066	-0.0537	0.0432	-0.1226	-0.1226	-0.1226	-0.1226	-0.1226	-0.7114	
0.500	-0.1191	-0.0578	0.0132	-0.1149	-0.1149	-0.1149	-0.1149	-0.1149	-0.7141	
0.525	*****	-0.0640	0.0083	-0.1171	-0.1171	-0.1171	-0.1171	-0.1171	-0.7108	
0.550	-0.1246	-0.0734	0.0046	-0.1131	-0.1131	-0.1131	-0.1131	-0.1131	-0.7104	
0.575	*****	-0.0779	0.0081	-0.1150	-0.1150	-0.1150	-0.1150	-0.1150	-0.7181	
0.600	-0.1379	-0.0841	-0.0106	-0.1160	-0.1160	-0.1160	-0.1160	-0.1160	-0.7137	
0.625	*****	*****	-0.0129	-0.1139	-0.1139	-0.1139	-0.1139	-0.1139	-0.7084	
0.650	-0.1452	-0.0913	-0.0175	-0.1147	-0.1147	-0.1147	-0.1147	-0.1147	-0.7088	
0.675	*****	-0.1104	-0.0325	-0.1195	-0.1195	-0.1195	-0.1195	-0.1195	-0.6997	
0.700	-0.1493	-0.1258	-0.0391	-0.1207	-0.1207	-0.1207	-0.1207	-0.1207	-0.7059	
0.725	*****	-0.1413	*****	-0.1261	-0.1261	-0.1261	-0.1261	-0.1261	-0.7058	
0.750	-0.1508	-0.1550	*****	-0.1311	-0.1311	-0.1311	-0.1311	-0.1311	-0.7003	
0.775	*****	-0.1710	-0.0875	-0.1420	-0.1420	-0.1420	-0.1420	-0.1420	-0.7006	
0.800	-0.1394	-0.1849	-0.1101	-0.1553	*****	*****	*****	*****	*****	
0.825	*****	-0.1956	-0.1380	-0.1569	-0.1569	-0.1569	-0.1569	-0.1569	-0.7079	
0.850	-0.1258	-0.2039	-0.1658	-0.1984	-0.1984	-0.1984	-0.1984	-0.1984	-0.6577	
0.875	*****	-0.2095	-0.1931	-0.2300	-0.2300	-0.2300	-0.2300	-0.2300	-0.4594	
0.900	-0.1089	-0.2115	-0.2152	-0.2696	-0.2696	-0.2696	-0.2696	-0.2696	-0.4179	
0.925	*****	-0.2058	-0.2311	-0.2952	-0.2952	-0.2952	-0.2952	-0.2952	-0.5016	
0.950	-0.0726	-0.1860	-0.2318	-0.3050	-0.3050	-0.3050	-0.3050	-0.3050	-0.4821	
0.975	*****	-0.1608	-0.2108	-0.2939	-0.2939	-0.2939	-0.2939	-0.2939	-0.4128	
1.000	0.1333	0.0515	0.0086	-0.0935	-0.1237	*****	*****	*****	*****	
	$C_{p,l}$	$C_{p,l}$	$C_{p,l}$	$C_{p,l}$	$C_{p,l}$	$C_{p,l}$	$C_{p,l}$	$C_{p,l}$	$C_{p,l}$	
-0.200	0.0500	0.0653	0.1444	*****	*****	*****	*****	*****	-0.6456	
-0.400	0.0319	0.0708	0.1104	-0.0432	-0.6913	*****	*****	*****	*****	
-0.600	0.0292	0.0586	0.0915	-0.0195	-0.6757	*****	*****	*****	*****	
-0.700	0.0406	0.0390	0.0816	-0.0079	-0.6555	*****	*****	*****	*****	
-0.800	0.0715	*****	0.0568	-0.0024	-0.6152	*****	*****	*****	*****	
-0.850	*****	0.0544	0.0522	-0.0079	-0.6283	*****	*****	*****	*****	
-0.900	*****	0.0857	0.0671	-0.0049	-0.6638	*****	*****	*****	*****	
-0.950	0.1821	0.1449	0.1248	0.0464	-0.2373	*****	*****	*****	*****	
-0.975	*****	0.1932	0.1768	0.1087	-0.0991	*****	*****	*****	*****	
-1.000	0.1081	0.0502	-0.0621	-0.0516	-0.0818	*****	*****	*****	*****	

Medium Radius L.E.
 Run No. = 32, Point No. = 640
 $C_N = 0.118$, $C_m = -0.0207$
 $\alpha = 2.8^\circ$, $M_\infty = 0.900$
 $R_{mac} = 120.4 \times 10^6$

Leading Edge Pressures

● starboard
 ○ port

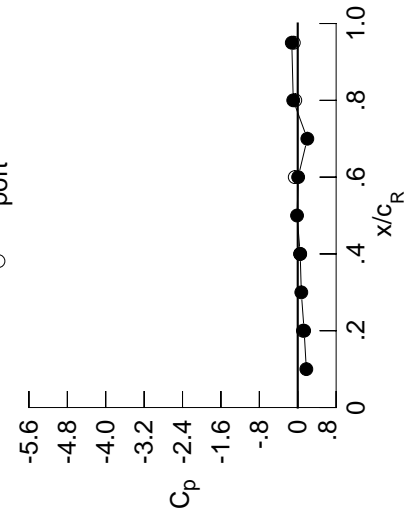

x/c_R	starb'd C_p	port C_p
0.10	0.1789	*****
0.20	0.1333	0.1081
0.30	0.0743	*****
0.40	0.0515	0.0502
0.50	-0.0141	*****
0.60	0.0086	-0.0621
0.70	0.1997	*****
0.80	-0.0935	-0.0516
0.90	*****	*****
0.95	-0.1237	-0.0818

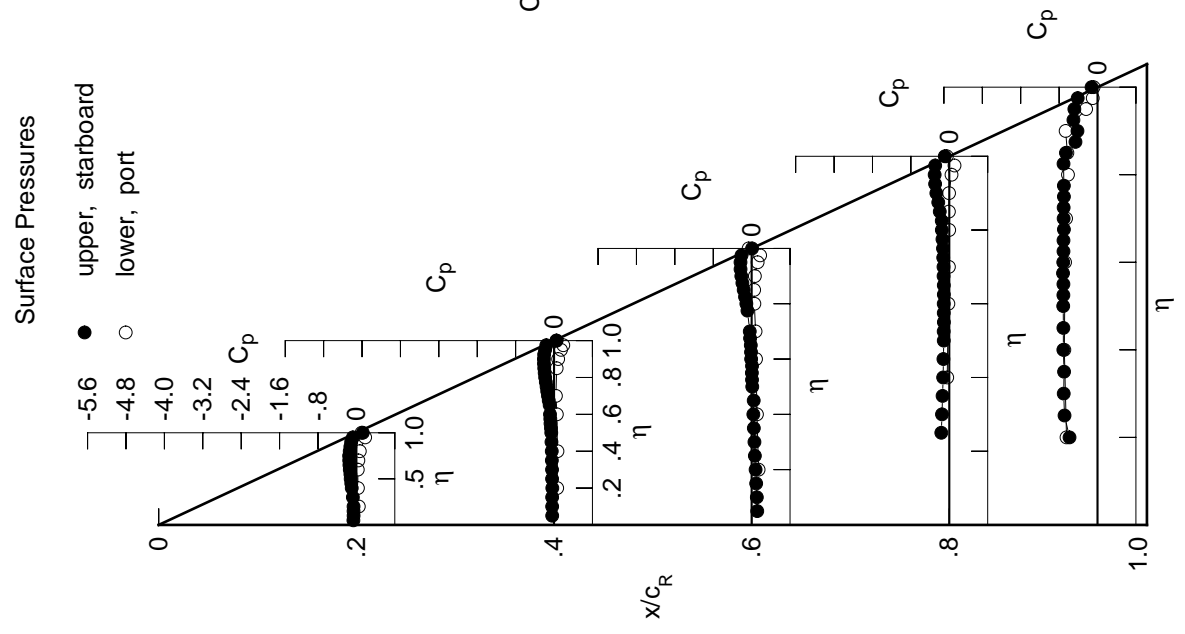
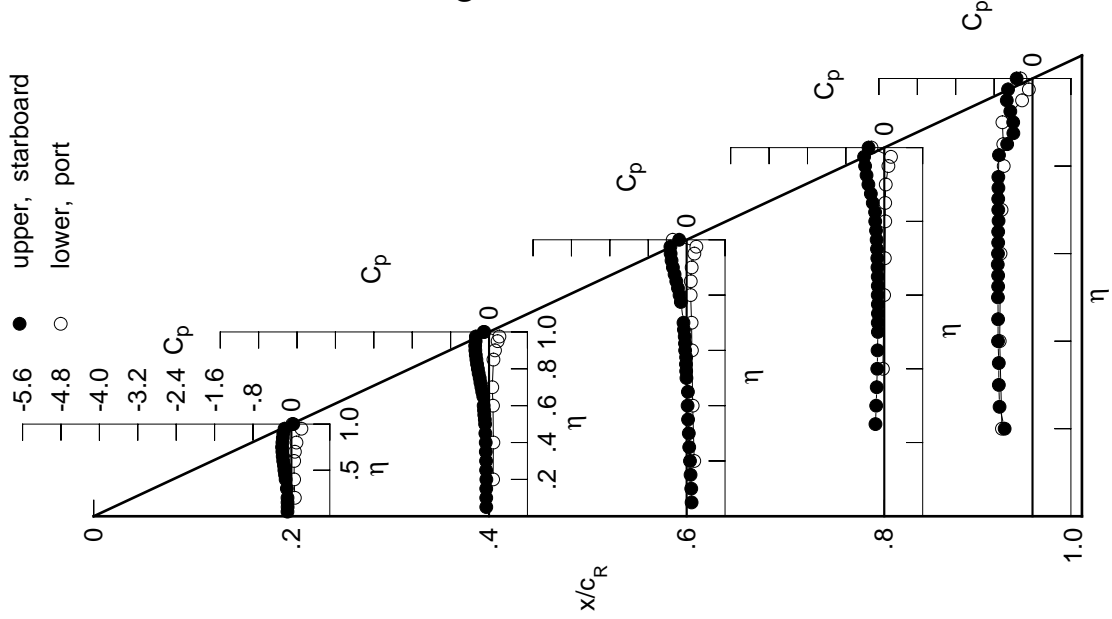

Table H4. Continued.

η	x/c_R .2	x/c_R .4	x/c_R .6	x/c_R .8	x/c_R .95
	$C_{p,u}$	$C_{p,u}$	$C_{p,u}$	$C_{p,u}$	$C_{p,u}$
0.050	-0.0817	-0.0580	0.1035	*****	*****
0.100	-0.0784	-0.0580	0.0957	*****	*****
0.150	-0.0798	-0.0588	0.0818	*****	*****
0.200	-0.0807	-0.0556	0.0697	*****	-0.5809
0.250	*****	-0.0606	0.0537	-0.1836	-0.6865
0.300	-0.0945	-0.0618	0.0450	-0.1687	-0.7019
0.350	*****	-0.0672	0.0300	-0.1575	-0.7022
0.400	-0.1203	-0.0691	0.0203	-0.1461	-0.7188
0.450	-0.1317	-0.0766	0.0263	-0.1402	-0.7167
0.500	-0.1461	-0.0816	-0.0039	-0.1338	-0.7196
0.525	*****	-0.0884	-0.0094	-0.1356	-0.7161
0.550	-0.1542	-0.0992	-0.0144	-0.1328	-0.7161
0.575	*****	-0.1048	-0.0113	-0.1347	-0.7238
0.600	-0.1703	-0.1119	-0.0311	-0.1369	-0.7195
0.625	*****	*****	-0.0342	-0.1353	-0.7150
0.650	-0.1808	-0.1201	-0.0397	-0.1372	-0.7152
0.675	*****	-0.1420	-0.0565	-0.1422	-0.7072
0.700	-0.1883	-0.1593	-0.0653	-0.1460	-0.7134
0.725	*****	-0.1788	*****	-0.1517	-0.7145
0.750	-0.1944	-0.1948	*****	-0.1592	-0.7102
0.775	*****	-0.2156	-0.1206	-0.1723	-0.7120
0.800	-0.1874	-0.2332	-0.1477	-0.1891	*****
0.825	*****	-0.2494	-0.1812	-0.1918	-0.6988
0.850	-0.1782	-0.2632	-0.2162	-0.2399	-0.5279
0.875	*****	-0.2758	-0.2515	-0.2801	-0.3996
0.900	-0.1685	-0.2855	-0.2867	-0.3312	-0.4023
0.925	*****	-0.2884	-0.3148	-0.3694	-0.4624
0.950	-0.1425	-0.2795	-0.3334	-0.4002	-0.5363
0.975	*****	-0.2744	-0.3384	-0.4206	-0.5097
1.000	0.0390	-0.1119	-0.1558	-0.3279	-0.3301
	$C_{p,l}$	$C_{p,l}$	$C_{p,l}$	$C_{p,l}$	$C_{p,l}$
-0.200	0.0724	0.0851	0.1584	*****	-0.6366
-0.400	0.0567	0.0907	0.1259	-0.0287	-0.6835
-0.600	0.0580	0.0827	0.1097	-0.0039	-0.6660
-0.700	0.0727	0.0669	0.1029	0.0109	-0.6447
-0.800	0.1055	*****	0.0835	0.0202	-0.5998
-0.850	*****	0.0920	0.0853	0.0195	-0.6086
-0.900	*****	0.1241	0.1048	0.0300	-0.6276
-0.950	0.2088	0.1791	0.1609	0.0853	-0.2172
-0.975	*****	0.2158	0.2028	0.1392	-0.0758
-1.000	0.0190	-0.0985	-0.2906	-0.2663	-0.2505

Surface Pressures



Medium Radius L.E.
Run No. = 32, Point No. = 641
 $C_N = 0.163$, $C_m = -0.0286$
 $\alpha = 3.9^\circ$, $M_\infty = 0.900$
 $R_{mac} = 120.4 \times 10^6$

Leading Edge Pressures

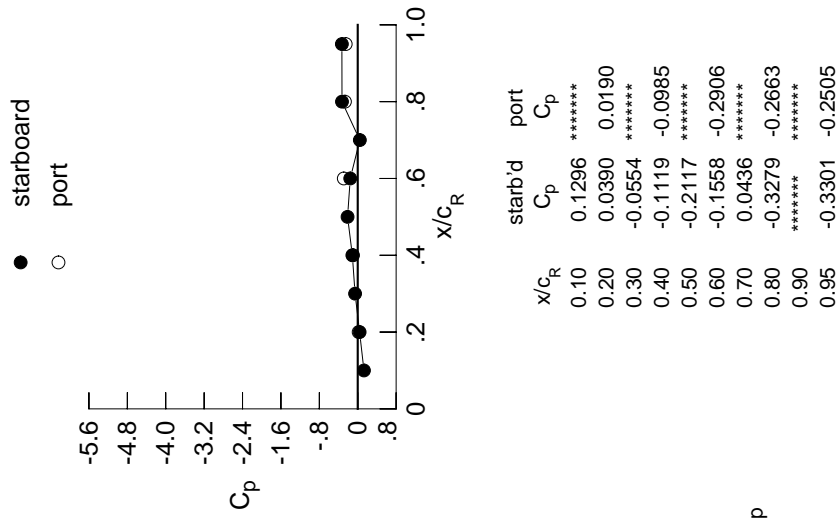
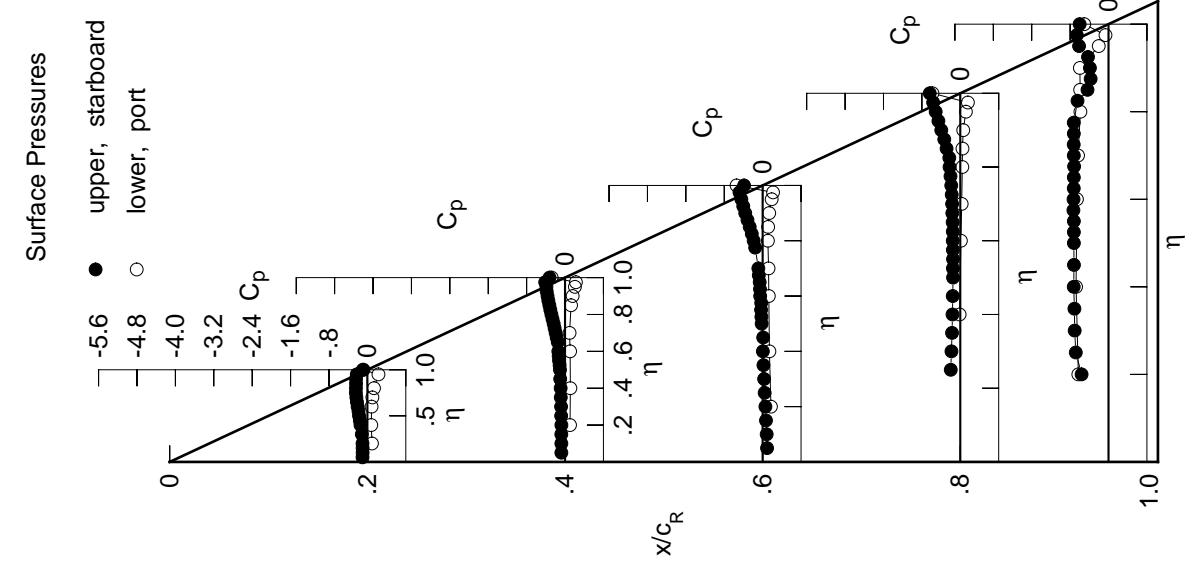
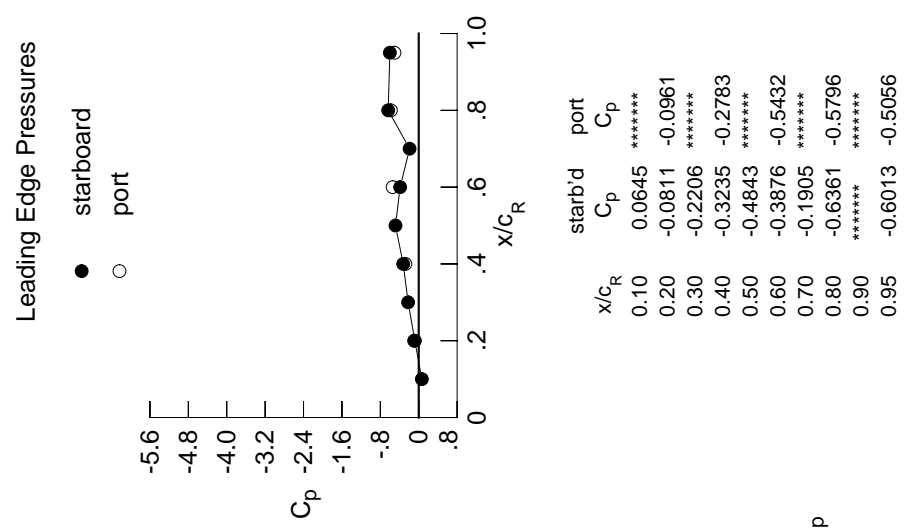

Table H4. Continued.

η	$x/c_R = .2$		$x/c_R = .4$		$x/c_R = .6$		$x/c_R = .8$		$x/c_R = .95$	
	$C_{p,u}$	$C_{p,u}$	$C_{p,u}$	$C_{p,u}$	$C_{p,u}$	$C_{p,u}$	$C_{p,u}$	$C_{p,u}$	$C_{p,u}$	$C_{p,u}$
0.050	-0.1016	-0.0767	0.0922	0.0922	0.0922	0.0922	0.0922	0.0922	0.0922	0.0922
0.100	-0.0989	-0.0772	0.0841	0.0841	0.0841	0.0841	0.0841	0.0841	0.0841	0.0841
0.150	-0.1000	-0.0775	0.0699	0.0699	0.0699	0.0699	0.0699	0.0699	0.0699	0.0699
0.200	-0.1013	-0.0759	0.0577	0.0577	0.0577	0.0577	0.0577	0.0577	0.0577	0.0577
0.250	*****	-0.0810	0.0414	0.0414	-0.1984	-0.1984	-0.6814	-0.6814	-0.6814	-0.6814
0.300	-0.1157	-0.0826	0.0316	0.0316	-0.1841	-0.1841	-0.7047	-0.7047	-0.7047	-0.7047
0.350	*****	-0.0886	0.0167	0.0167	-0.1723	-0.1723	-0.7103	-0.7103	-0.7103	-0.7103
0.400	-0.1442	-0.0910	0.0050	0.0050	-0.1624	-0.1624	-0.7246	-0.7246	-0.7246	-0.7246
0.450	-0.1575	-0.1004	0.0109	0.0109	-0.1575	-0.1575	-0.7199	-0.7199	-0.7199	-0.7199
0.500	-0.1737	-0.1059	-0.0204	-0.1513	-0.7217	-0.7217	-0.7217	-0.7217	-0.7217	-0.7217
0.525	*****	-0.1138	-0.0266	-0.1540	-0.7216	-0.7216	-0.7216	-0.7216	-0.7216	-0.7216
0.550	-0.1844	-0.1251	-0.0324	-0.1511	-0.7219	-0.7219	-0.7219	-0.7219	-0.7219	-0.7219
0.575	*****	-0.1328	-0.0298	-0.1543	-0.7315	-0.7315	-0.7315	-0.7315	-0.7315	-0.7315
0.600	-0.2031	-0.1403	-0.0508	-0.1567	-0.7288	-0.7288	-0.7288	-0.7288	-0.7288	-0.7288
0.625	*****	*****	-0.0555	-0.1562	-0.7243	-0.7243	-0.7243	-0.7243	-0.7243	-0.7243
0.650	-0.2174	-0.1514	-0.0618	-0.1593	-0.7223	-0.7223	-0.7223	-0.7223	-0.7223	-0.7223
0.675	*****	-0.1747	-0.0798	-0.1661	-0.7165	-0.7165	-0.7165	-0.7165	-0.7165	-0.7165
0.700	-0.2295	-0.1951	-0.0896	-0.1703	-0.7235	-0.7235	-0.7235	-0.7235	-0.7235	-0.7235
0.725	*****	-0.2166	*****	-0.1788	-0.7248	-0.7248	-0.7248	-0.7248	-0.7248	-0.7248
0.750	-0.2398	-0.2372	*****	-0.1878	-0.7227	-0.7227	-0.7227	-0.7227	-0.7227	-0.7227
0.775	*****	-0.2608	-0.1550	-0.2039	-0.7238	-0.7238	-0.7238	-0.7238	-0.7238	-0.7238
0.800	-0.2386	-0.2844	-0.1869	-0.2236	*****	*****	*****	*****	*****	*****
0.825	*****	-0.3062	-0.2263	-0.2290	-0.6454	-0.6454	-0.6454	-0.6454	-0.6454	-0.6454
0.850	-0.2361	-0.3265	-0.2693	-0.2853	-0.4374	-0.4374	-0.4374	-0.4374	-0.4374	-0.4374
0.875	*****	-0.3472	-0.3164	-0.3333	-0.3723	-0.3723	-0.3723	-0.3723	-0.3723	-0.3723
0.900	-0.2367	-0.3651	-0.3621	-0.3963	-0.3868	-0.3868	-0.3868	-0.3868	-0.3868	-0.3868
0.925	*****	-0.3816	-0.4040	-0.4562	-0.4274	-0.4274	-0.4274	-0.4274	-0.4274	-0.4274
0.950	-0.2215	-0.3869	-0.4430	-0.5125	-0.6136	-0.6136	-0.6136	-0.6136	-0.6136	-0.6136
0.975	*****	-0.4140	-0.4822	-0.5655	-0.6599	-0.6599	-0.6599	-0.6599	-0.6599	-0.6599
1.000	-0.0811	-0.3235	-0.3876	-0.6361	-0.6013	-0.6013	-0.6013	-0.6013	-0.6013	-0.6013
0.200	0.0952	0.1039	0.1730	0.1730	0.1730	0.1730	0.1730	0.1730	0.1730	0.1730
0.400	0.0812	0.1112	0.1410	0.1410	0.1410	0.1410	0.1410	0.1410	0.1410	0.1410
0.600	0.0875	0.1060	0.1285	0.1285	0.1285	0.1285	0.1285	0.1285	0.1285	0.1285
0.700	0.1040	0.0944	0.1236	0.1236	0.1236	0.1236	0.1236	0.1236	0.1236	0.1236
0.800	0.1380	0.0944	0.1095	0.1095	0.1095	0.1095	0.1095	0.1095	0.1095	0.1095
0.850	*****	0.1258	0.1146	0.1146	0.1146	0.1146	0.1146	0.1146	0.1146	0.1146
0.900	*****	0.1581	0.1370	0.1370	0.1370	0.1370	0.1370	0.1370	0.1370	0.1370
0.950	0.2301	0.2054	0.1884	0.1884	0.1884	0.1884	0.1884	0.1884	0.1884	0.1884
0.975	*****	0.2266	0.2167	0.2167	0.2167	0.2167	0.2167	0.2167	0.2167	0.2167
1.000	-0.0961	-0.2783	-0.5432	-0.5432	-0.5432	-0.5432	-0.5432	-0.5432	-0.5432	-0.5432

Medium Radius L.E.
 Run No. = 32, Point No. = 642
 $C_N = 0.210$, $C_m = -0.0377$
 $\alpha = 4.9^\circ$, $M_\infty = 0.900$
 $R_{mac} = 120.4 \times 10^6$



x/c_R	starb'd C_p	port C_p
0.10	0.0645	*****
0.20	-0.0811	-0.0961
0.30	-0.2206	*****
0.40	-0.3235	-0.2783
0.50	-0.4843	*****
0.60	-0.3876	-0.5432
0.70	-0.1905	*****
0.80	-0.6361	-0.5796
0.90	*****	*****
0.95	-0.6013	-0.5056

Table H4. Continued.

η	$x/c_R = .2$		$x/c_R = .4$		$x/c_R = .6$		$x/c_R = .8$		$x/c_R = .95$	
	$C_{p,u}$	$C_{p,u}$	$C_{p,u}$	$C_{p,u}$	$C_{p,u}$	$C_{p,u}$	$C_{p,u}$	$C_{p,u}$	$C_{p,u}$	$C_{p,u}$
0.050	-0.1193	-0.0945	0.0806	*****	*****	*****	*****	*****	*****	
0.100	-0.1179	-0.0954	0.0719	*****	*****	*****	*****	*****	*****	
0.150	-0.1192	-0.0970	0.0584	*****	*****	*****	*****	*****	*****	
0.200	-0.1209	-0.0945	0.0452	*****	*****	*****	*****	*****	-0.5664	
0.250	*****	-0.1003	0.0286	-0.2127	-0.6773	*****	*****	*****	*****	
0.300	-0.1370	-0.1028	0.0189	-0.1986	-0.7105	*****	*****	*****	*****	
0.350	*****	-0.1097	0.0034	-0.1874	-0.7169	*****	*****	*****	*****	
0.400	-0.1679	-0.1123	-0.0094	-0.1771	-0.7256	*****	*****	*****	*****	
0.450	-0.1829	-0.1231	-0.0048	-0.1734	-0.7201	*****	*****	*****	*****	
0.500	-0.2014	-0.1296	-0.0371	-0.1677	-0.7283	*****	*****	*****	*****	
0.525	*****	-0.1391	-0.0441	-0.1708	-0.7302	*****	*****	*****	*****	
0.550	-0.2145	-0.1517	-0.0505	-0.1690	-0.7327	*****	*****	*****	*****	
0.575	*****	-0.1602	-0.0495	-0.1721	-0.7413	*****	*****	*****	*****	
0.600	-0.2365	-0.1699	-0.0712	-0.1758	-0.7376	*****	*****	*****	*****	
0.625	*****	*****	-0.0770	-0.1760	-0.7328	*****	*****	*****	*****	
0.650	-0.2550	-0.1835	-0.0844	-0.1810	-0.7428	*****	*****	*****	*****	
0.675	*****	-0.2082	-0.1044	-0.1903	-0.7274	*****	*****	*****	*****	
0.700	-0.2723	-0.2312	-0.1169	-0.1970	-0.7337	*****	*****	*****	*****	
0.725	*****	-0.2566	*****	-0.2089	-0.7377	*****	*****	*****	*****	
0.750	-0.2875	-0.2808	*****	-0.2217	-0.7370	*****	*****	*****	*****	
0.775	*****	-0.3097	-0.1910	-0.2407	-0.7277	*****	*****	*****	*****	
0.800	-0.2927	-0.3382	-0.2264	-0.2608	*****	*****	*****	*****	*****	
0.825	*****	-0.3684	-0.2710	-0.2695	-0.5804	*****	*****	*****	*****	
0.850	-0.2943	-0.3967	-0.3208	-0.3245	-0.4194	*****	*****	*****	*****	
0.875	*****	-0.4279	-0.3767	-0.3818	-0.3770	*****	*****	*****	*****	
0.900	-0.3069	-0.4558	-0.4367	-0.4589	-0.4028	*****	*****	*****	*****	
0.925	*****	-0.4862	-0.5008	-0.5336	-0.4281	*****	*****	*****	*****	
0.950	-0.3129	-0.5081	-0.5701	-0.6106	-0.7143	*****	*****	*****	*****	
0.975	*****	-0.5679	-0.6463	-0.6971	-0.7901	*****	*****	*****	*****	
1.000	-0.2289	-0.5875	-0.5958	-0.9008	-0.8379	*****	*****	*****	*****	
-0.200	$C_{p,l}$	0.1201	0.1261	0.1886	*****	*****	*****	*****	-0.6205	
-0.400		0.1085	0.1346	0.1588	0.0018	-0.6690	*****	*****	*****	
-0.600		0.1180	0.1317	0.1476	0.0302	-0.6485	*****	*****	*****	
-0.700		0.1366	0.1228	0.1459	0.0474	-0.6244	*****	*****	*****	
-0.800		0.1703	*****	0.1361	0.0643	-0.5720	*****	*****	*****	
-0.850		*****	0.1593	0.1443	0.0713	-0.5742	*****	*****	*****	
-0.900		*****	0.1902	0.1671	0.0913	-0.5703	*****	*****	*****	
-0.950		0.2467	0.2267	0.2102	0.1422	-0.1934	*****	*****	*****	
-0.975		*****	0.2277	0.2200	0.1679	-0.0610	*****	*****	*****	
-1.000		-0.2409	-0.5082	-0.7731	-0.8271	-0.7460	*****	*****	*****	

Medium Radius L.E.
 Run No. = 32, Point No. = 643
 $C_N = 0.258$, $C_m = -0.0454$
 $\alpha = 6.1^\circ$, $M_\infty = 0.899$
 $R_{mac} = 120.2 \times 10^6$

Leading Edge Pressures

● starboard
 ○ port

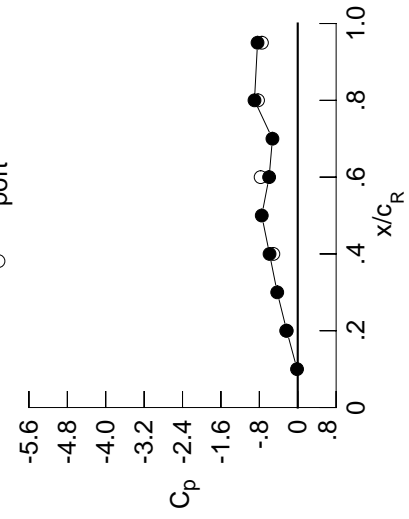

x/c_R	starb'd C_p	port C_p
0.10	-0.0140	*****
0.20	-0.2289	-0.2409
0.30	-0.4274	*****
0.40	-0.5875	-0.5082
0.50	-0.7498	*****
0.60	-0.5958	-0.7731
0.70	-0.5269	*****
0.80	-0.9008	-0.8271
0.90	*****	*****
0.95	-0.8379	-0.7460

Surface Pressures

● upper, starboard
 ○ lower, port

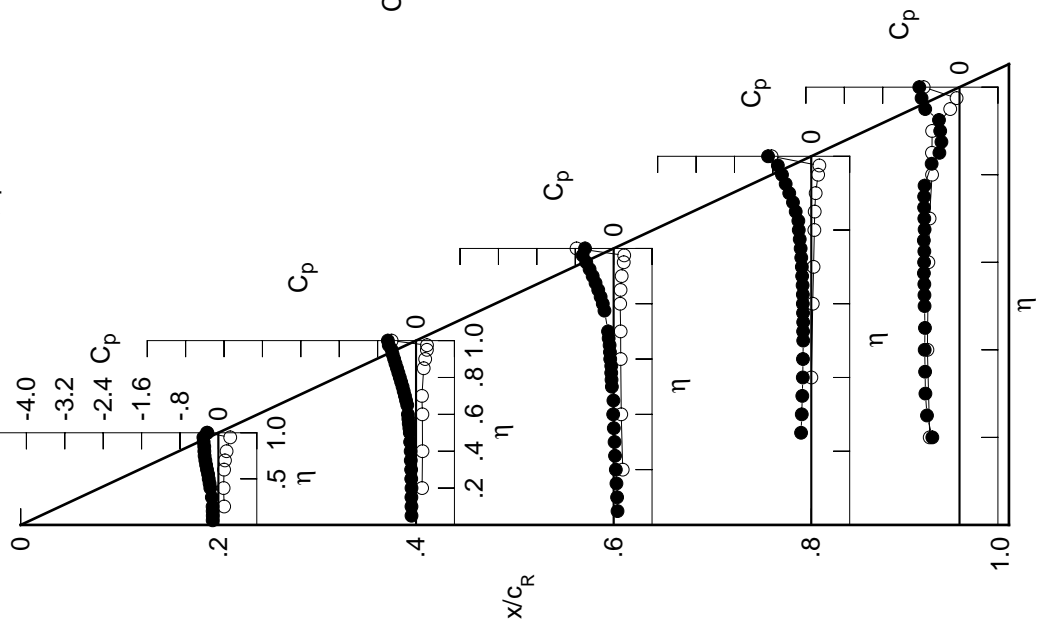
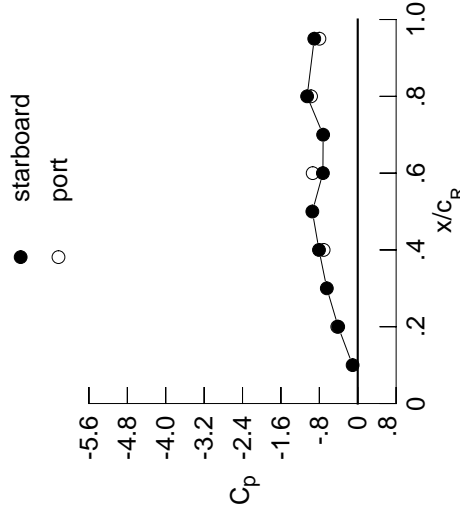

Table H4. Continued.

η	$x/c_R = .2$		$x/c_R = .4$		$x/c_R = .6$		$x/c_R = .8$		$x/c_R = .95$	
	$C_{p,u}$	$C_{p,u}$	$C_{p,u}$	$C_{p,u}$	$C_{p,u}$	$C_{p,u}$	$C_{p,u}$	$C_{p,u}$	$C_{p,u}$	$C_{p,u}$
0.050	-0.1368	-0.1135	0.0701	*****	*****	*****	*****	*****	*****	*****
0.100	-0.1365	-0.1149	0.0608	*****	*****	*****	*****	*****	*****	*****
0.150	-0.1382	-0.1165	0.0472	*****	*****	*****	*****	*****	*****	*****
0.200	-0.1406	-0.1141	0.0338	*****	*****	*****	*****	*****	*****	-0.5779
0.250	*****	-0.1207	0.0168	-0.2278	-0.6712	*****	*****	*****	*****	*****
0.300	-0.1572	-0.1230	0.0065	-0.2140	-0.7035	*****	*****	*****	*****	*****
0.350	*****	-0.1315	-0.0100	-0.2030	-0.6679	*****	*****	*****	*****	*****
0.400	-0.1901	-0.1350	-0.0226	-0.1936	-0.7173	*****	*****	*****	*****	*****
0.450	-0.2066	-0.1475	-0.0203	-0.1892	-0.7262	*****	*****	*****	*****	*****
0.500	-0.2273	-0.1548	-0.0532	-0.1871	-0.7023	*****	*****	*****	*****	*****
0.525	*****	-0.1653	-0.0617	-0.1925	-0.7277	*****	*****	*****	*****	*****
0.550	-0.2436	-0.1793	-0.0690	-0.1907	-0.7347	*****	*****	*****	*****	*****
0.575	*****	-0.1891	-0.0699	-0.1937	-0.7459	*****	*****	*****	*****	*****
0.600	-0.2691	-0.2005	-0.0945	-0.1995	-0.7428	*****	*****	*****	*****	*****
0.625	*****	*****	-0.1028	-0.2028	-0.7331	*****	*****	*****	*****	*****
0.650	-0.2918	-0.2171	-0.1134	-0.2120	-0.7382	*****	*****	*****	*****	*****
0.675	*****	-0.2433	-0.1331	-0.2255	-0.7449	*****	*****	*****	*****	*****
0.700	-0.3128	-0.2691	-0.1471	-0.2344	-0.7584	*****	*****	*****	*****	*****
0.725	*****	-0.2969	*****	-0.2466	-0.7711	*****	*****	*****	*****	*****
0.750	-0.3355	-0.3248	*****	-0.2591	-0.7645	*****	*****	*****	*****	*****
0.775	*****	-0.3582	-0.2256	-0.2807	-0.7612	*****	*****	*****	*****	*****
0.800	-0.3599	-0.3946	-0.2604	-0.3070	*****	*****	*****	*****	*****	*****
0.825	*****	-0.4316	-0.3055	-0.3290	-0.7667	*****	*****	*****	*****	*****
0.850	-0.3682	-0.4658	-0.3595	-0.4156	-0.7464	*****	*****	*****	*****	*****
0.875	*****	-0.5059	-0.4227	-0.4318	-0.7909	*****	*****	*****	*****	*****
0.900	-0.3843	-0.5480	-0.4916	-0.4736	-0.7513	*****	*****	*****	*****	*****
0.925	*****	-0.5958	-0.5622	-0.5665	-0.7363	*****	*****	*****	*****	*****
0.950	-0.4124	-0.6264	-0.6778	-0.7627	-0.6172	*****	*****	*****	*****	*****
0.975	*****	-0.7105	-1.0434	-0.9701	-0.6839	*****	*****	*****	*****	*****
1.000	-0.4070	-0.8070	-0.7257	-1.0543	-0.9056	*****	*****	*****	*****	*****
	$C_{p,l}$	$C_{p,l}$	$C_{p,l}$	$C_{p,l}$	$C_{p,l}$	$C_{p,l}$	$C_{p,l}$	$C_{p,l}$	$C_{p,l}$	$C_{p,l}$
-0.200	0.1460	0.1485	0.2055	*****	*****	*****	*****	*****	*****	-0.6087
-0.400	0.1353	0.1575	0.1765	0.0184	-0.6585	*****	*****	*****	*****	*****
-0.600	0.1482	0.1568	0.1669	0.0479	-0.6363	*****	*****	*****	*****	*****
-0.700	0.1677	0.1506	0.1670	0.0662	-0.6112	*****	*****	*****	*****	*****
-0.800	0.2002	*****	0.1600	0.0851	-0.5563	*****	*****	*****	*****	*****
-0.850	*****	0.1892	0.1703	0.0949	-0.5557	*****	*****	*****	*****	*****
-0.900	*****	0.2169	0.1925	0.1164	-0.5442	*****	*****	*****	*****	*****
-0.950	0.2563	0.2406	0.2245	0.1619	-0.1797	*****	*****	*****	*****	*****
-0.975	*****	0.2200	0.2160	0.1724	-0.0514	*****	*****	*****	*****	*****
-1.000	-0.4268	-0.7107	-0.9380	-0.9726	-0.7983	*****	*****	*****	*****	*****

Medium Radius L.E.
 Run No. = 32, Point No. = 644
 $C_N = 0.313$, $C_m = -0.0577$
 $\alpha = 7.1^\circ$, $M_\infty = 0.900$
 $R_{mac} = 120.4 \times 10^6$

Leading Edge Pressures



x/c_R	starb'd C_p	port C_p
0.10	-0.1061	*****
0.20	-0.4070	-0.4268
0.30	-0.6438	*****
0.40	-0.8070	-0.7107
0.50	-0.9453	*****
0.60	-0.7257	-0.9380
0.70	-0.7207	*****
0.80	-1.0543	-0.9726
0.90	*****	*****
0.95	-0.9056	-0.7983

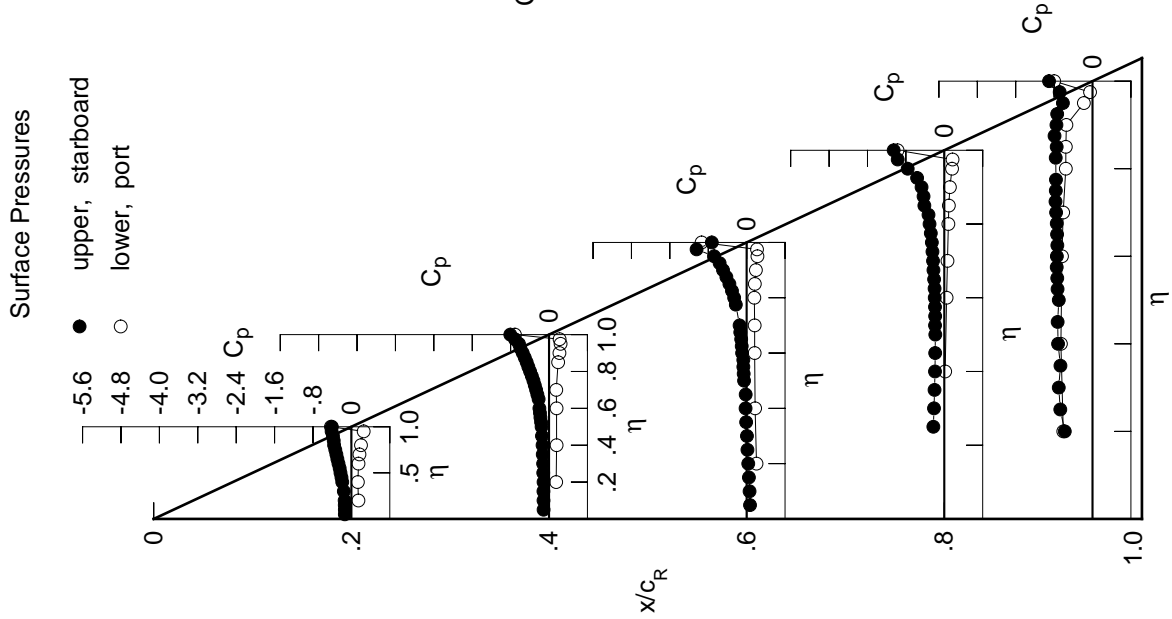

Table H4. Continued.

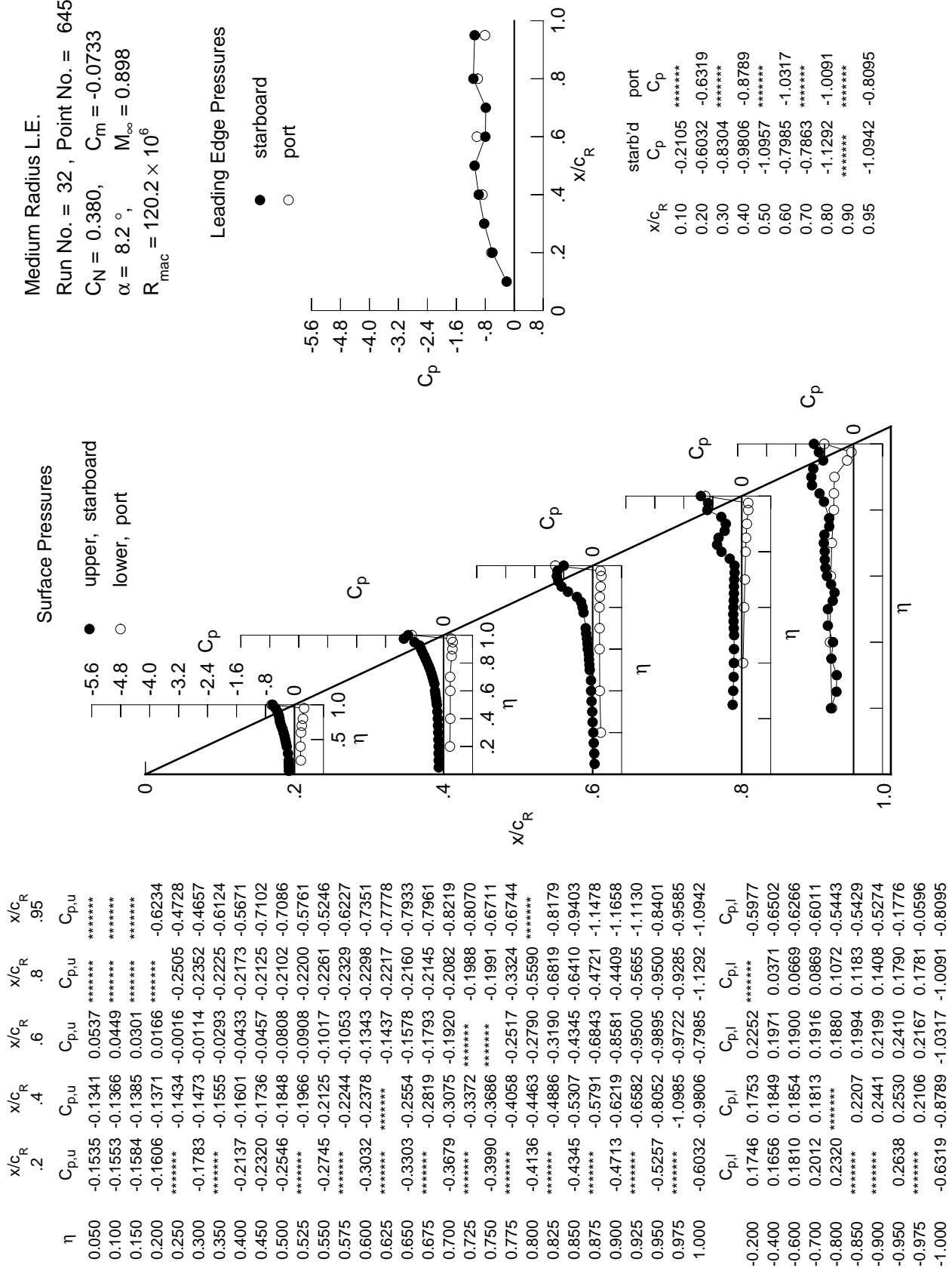
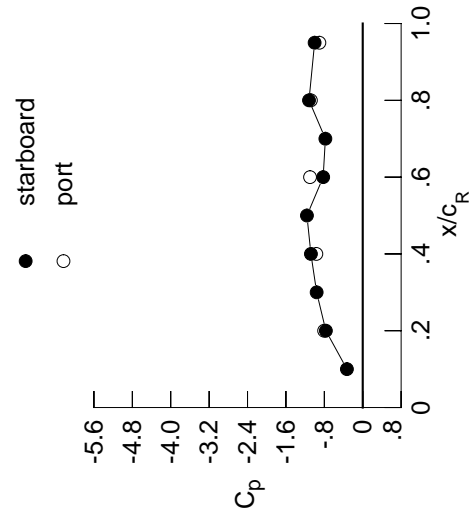

Table H4. Continued.

η	$x/c_R = .2$		$x/c_R = .4$		$x/c_R = .6$		$x/c_R = .8$		$x/c_R = .95$	
	$C_{p,u}$	$C_{p,u}$	$C_{p,u}$	$C_{p,u}$	$C_{p,u}$	$C_{p,u}$	$C_{p,u}$	$C_{p,u}$	$C_{p,u}$	$C_{p,u}$
0.050	-0.1676	-0.1563	0.0375	*****	*****	*****	*****	*****	*****	*****
0.100	-0.1725	-0.1604	0.0281	*****	*****	*****	*****	*****	*****	*****
0.150	-0.1767	-0.1621	0.0121	*****	*****	*****	*****	*****	*****	*****
0.200	-0.1803	-0.1614	-0.0024	*****	*****	*****	*****	*****	*****	*****
0.250	*****	-0.1688	-0.0196	-0.2766	-0.3910	*****	*****	*****	*****	*****
0.300	-0.1997	-0.1722	-0.0281	-0.2620	-0.5886	*****	*****	*****	*****	*****
0.350	*****	-0.1809	-0.0533	-0.2502	-0.7107	*****	*****	*****	*****	*****
0.400	-0.2376	-0.1872	-0.0654	-0.2447	-0.7589	*****	*****	*****	*****	*****
0.450	-0.2580	-0.2079	-0.0708	-0.2547	-0.4846	*****	*****	*****	*****	*****
0.500	-0.2834	-0.2201	-0.1189	-0.2403	-0.6621	*****	*****	*****	*****	*****
0.525	*****	-0.2320	-0.1299	-0.2375	-0.7381	*****	*****	*****	*****	*****
0.550	-0.3075	-0.2506	-0.1372	-0.2289	-0.7520	*****	*****	*****	*****	*****
0.575	*****	-0.2635	-0.1354	-0.2262	-0.7603	*****	*****	*****	*****	*****
0.600	-0.3440	-0.2765	-0.1514	-0.2229	-0.7500	*****	*****	*****	*****	*****
0.625	*****	*****	-0.1469	-0.2110	-0.7357	*****	*****	*****	*****	*****
0.650	-0.3803	-0.2959	-0.1465	-0.1995	-0.7405	*****	*****	*****	*****	*****
0.675	*****	-0.3206	-0.1558	-0.1905	-0.7622	*****	*****	*****	*****	*****
0.700	-0.4135	-0.3442	-0.1516	-0.1962	-0.8744	*****	*****	*****	*****	*****
0.725	*****	-0.3721	*****	-0.3066	-1.0451	*****	*****	*****	*****	*****
0.750	-0.4455	-0.4033	*****	-0.6063	-1.1684	*****	*****	*****	*****	*****
0.775	*****	-0.4394	-0.3358	-0.8864	-1.2100	*****	*****	*****	*****	*****
0.800	-0.4748	-0.4801	-0.8759	-0.9374	*****	*****	*****	*****	*****	*****
0.825	*****	-0.5226	-1.0053	-0.9559	-0.7051	*****	*****	*****	*****	*****
0.850	-0.5098	-0.5827	-0.9957	-0.9161	-0.6414	*****	*****	*****	*****	*****
0.875	*****	-0.6898	-0.9669	-0.7836	-0.6077	*****	*****	*****	*****	*****
0.900	-0.5623	-0.8459	-0.9289	-0.6911	-0.6248	*****	*****	*****	*****	*****
0.925	*****	-0.9967	-0.8837	-0.6499	-0.6599	*****	*****	*****	*****	*****
0.950	-0.6383	-1.1238	-0.8320	-0.6482	-0.5811	*****	*****	*****	*****	*****
0.975	*****	-1.2009	-0.8189	-0.6211	-0.7324	*****	*****	*****	*****	*****
1.000	-0.7679	-1.0795	-0.8244	-1.1194	-1.0024	*****	*****	*****	*****	*****
-0.200	$C_{p,l}$	$C_{p,l}$	$C_{p,l}$	$C_{p,l}$	$C_{p,l}$	$C_{p,l}$	$C_{p,l}$	$C_{p,l}$	$C_{p,l}$	$C_{p,l}$
-0.400	0.2057	0.2025	0.2450	*****	*****	*****	*****	*****	*****	*****
-0.600	0.1973	0.2123	0.2175	0.0548	-0.6376	*****	*****	*****	*****	*****
-0.700	0.2147	0.2144	0.2115	0.0853	-0.6122	*****	*****	*****	*****	*****
-0.800	0.2352	0.2124	0.2137	0.1061	-0.5858	*****	*****	*****	*****	*****
-0.850	0.2632	*****	0.2103	0.1270	-0.5282	*****	*****	*****	*****	*****
-0.900	*****	0.2506	0.2213	0.1388	-0.5252	*****	*****	*****	*****	*****
-0.950	*****	0.2691	0.2380	0.1611	-0.5058	*****	*****	*****	*****	*****
-0.975	0.2682	0.2634	0.2454	0.1911	-0.1709	*****	*****	*****	*****	*****
-1.000	*****	0.2010	0.2042	0.1751	-0.0660	*****	*****	*****	*****	*****
	-0.8043	-0.9663	-1.0973	-1.0803	-0.9029	*****	*****	*****	*****	*****

Medium Radius L.E.
 Run No. = 32, Point No. = 646
 $C_N = 0.442$, $C_m = -0.0850$
 $\alpha = 9.4^\circ$, $M_\infty = 0.900$
 $R_{mac} = 120.3 \times 10^6$

Leading Edge Pressures



x/c_R	starb'd C_p	port C_p
0.10	-0.3294	*****
0.20	-0.7679	-0.8043
0.30	-0.9598	*****
0.40	-1.0795	-0.9663
0.50	-1.1624	*****
0.60	-0.8244	-1.0973
0.70	-0.7780	*****
0.80	-1.1194	-1.0803
0.90	*****	*****
0.95	-1.0024	-0.9029

Surface Pressures

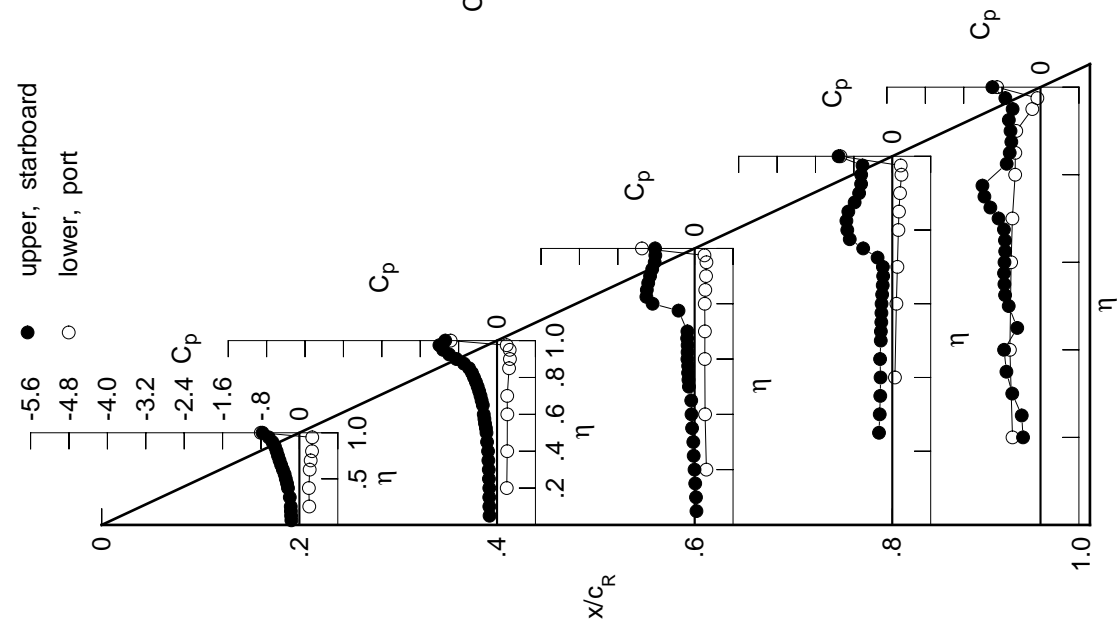

Table H4. Continued.

η	$x/c_R = .2$		$x/c_R = .4$		$x/c_R = .6$		$x/c_R = .8$		$x/c_R = .95$	
	$C_{p,u}$	$C_{p,u}$	$C_{p,u}$	$C_{p,u}$	$C_{p,u}$	$C_{p,u}$	$C_{p,u}$	$C_{p,u}$	$C_{p,u}$	$C_{p,u}$
0.050	-0.1819	-0.1866	0.0156	*****	*****	*****	*****	*****	*****	
0.100	-0.1894	-0.1925	0.0055	*****	*****	*****	*****	*****	*****	
0.150	-0.1958	-0.1940	-0.0108	*****	*****	*****	*****	*****	*****	
0.200	-0.2012	-0.1956	-0.0221	*****	*****	*****	*****	*****	-0.3523	
0.250	*****	-0.2009	-0.0439	-0.3018	-0.3018	-0.4633	*****	*****	*****	
0.300	-0.2218	-0.2059	-0.0556	-0.2877	-0.6139	*****	*****	*****	*****	
0.350	*****	-0.2205	-0.0776	-0.2850	-0.5904	*****	*****	*****	*****	
0.400	-0.2618	-0.2282	-0.1128	-0.2762	-0.5039	*****	*****	*****	*****	
0.450	-0.2851	-0.2527	-0.1071	-0.2601	-0.6064	*****	*****	*****	*****	
0.500	-0.3143	-0.2692	-0.1232	-0.2473	-0.6947	*****	*****	*****	*****	
0.525	*****	-0.2796	-0.1253	-0.2475	-0.7182	*****	*****	*****	*****	
0.550	-0.3387	-0.2936	-0.1284	-0.2383	-0.7017	*****	*****	*****	*****	
0.575	*****	-0.3005	-0.1205	-0.2348	-0.7001	*****	*****	*****	*****	
0.600	-0.3769	-0.3074	-0.1405	-0.2315	-0.6714	*****	*****	*****	*****	
0.625	*****	*****	-0.1320	-0.2283	-0.6664	*****	*****	*****	*****	
0.650	-0.4183	-0.3139	-0.1222	-0.2529	-0.7135	*****	*****	*****	*****	
0.675	*****	-0.3334	-0.1254	-0.3461	-0.7880	*****	*****	*****	*****	
0.700	-0.4566	-0.3444	-0.1623	-0.5376	-0.8711	*****	*****	*****	*****	
0.725	*****	-0.3534	*****	-0.7903	-0.8353	*****	*****	*****	*****	
0.750	-0.4950	-0.3827	*****	-0.9793	-0.7127	*****	*****	*****	*****	
0.775	*****	-0.5506	-1.1056	-1.0819	-0.6211	*****	*****	*****	*****	
0.800	-0.5313	-0.7888	-1.1014	-1.0209	*****	*****	*****	*****	*****	
0.825	*****	-0.9468	-1.0646	-0.9084	-0.5382	*****	*****	*****	*****	
0.850	-0.5723	-1.0126	-1.0293	-0.7529	-0.5166	*****	*****	*****	*****	
0.875	*****	-1.0486	-0.9698	-0.7157	-0.5572	*****	*****	*****	*****	
0.900	-0.6328	-1.0787	-0.8728	-0.6900	-0.6385	*****	*****	*****	*****	
0.925	*****	-1.0823	-0.7976	-0.6451	-0.6949	*****	*****	*****	*****	
0.950	-0.8603	-1.0839	-0.7496	-0.6850	-0.5970	*****	*****	*****	*****	
0.975	*****	-1.0742	-0.7215	-0.6321	-0.6502	*****	*****	*****	*****	
1.000	-0.8788	-1.1466	-0.8068	-1.1396	-0.8492	*****	*****	*****	*****	
-0.200	$C_{p,l}$	$C_{p,l}$	$C_{p,l}$	$C_{p,l}$	$C_{p,l}$	$C_{p,l}$	$C_{p,l}$	$C_{p,l}$	$C_{p,l}$	
-0.400	0.2377	0.2298	0.2644	*****	*****	-0.5719	*****	*****	*****	
-0.600	0.2304	0.2405	0.2379	0.0712	-0.6271	*****	*****	*****	*****	
-0.700	0.2489	0.2436	0.2326	0.1020	-0.6015	*****	*****	*****	*****	
-0.800	0.2694	0.2425	0.2363	0.1230	-0.5747	*****	*****	*****	*****	
-0.850	0.2938	*****	0.2339	0.1449	-0.5170	*****	*****	*****	*****	
-0.900	*****	0.2791	0.2452	0.1563	-0.5121	*****	*****	*****	*****	
-0.950	*****	0.2924	0.2596	0.1776	-0.4884	*****	*****	*****	*****	
-0.975	0.2716	0.2738	0.2573	0.1990	-0.1570	*****	*****	*****	*****	
-1.000	*****	0.1950	0.2030	0.1717	-0.0441	*****	*****	*****	*****	
	-0.9292	-1.0137	-1.1272	-1.0662	-0.5565	*****	*****	*****	*****	

Medium Radius L.E.
 Run No. = 32, Point No. = 647
 $C_N = 0.503$, $C_m = -0.0934$
 $\alpha = 10.5^\circ$, $M_\infty = 0.901$
 $R_{mac} = 120.3 \times 10^6$

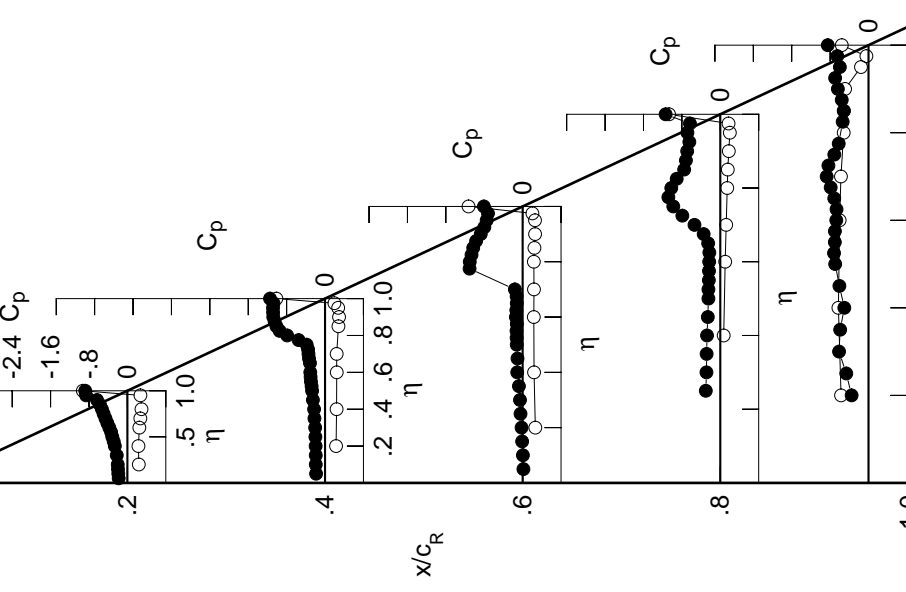
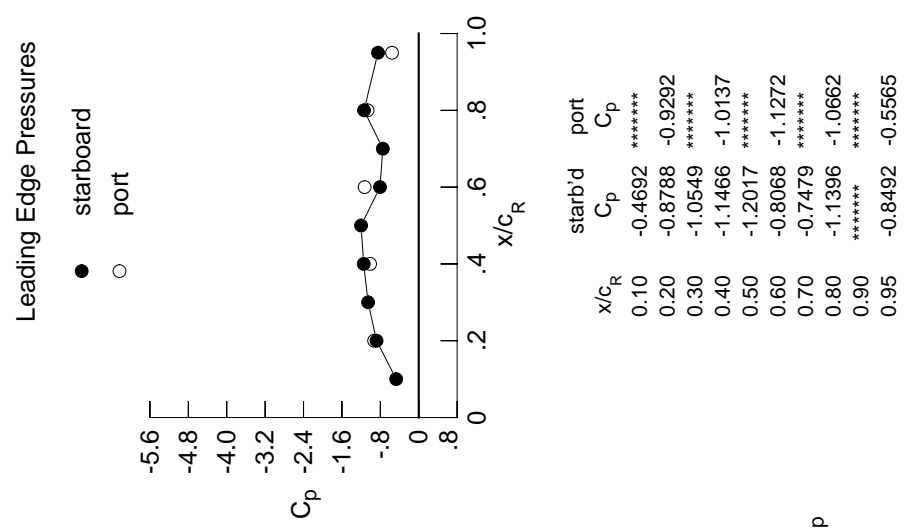
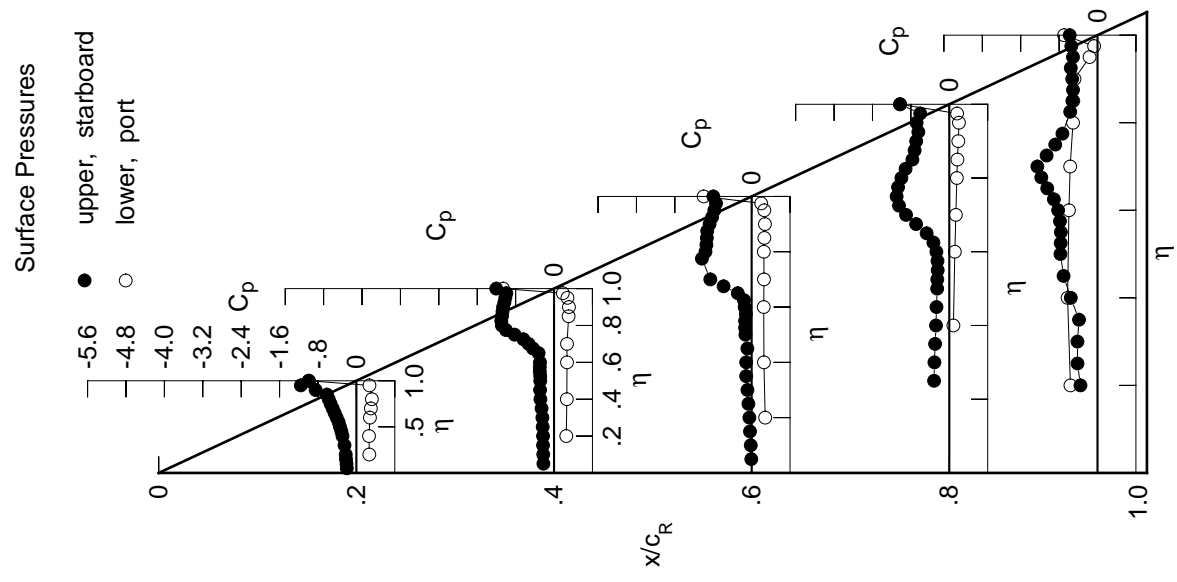
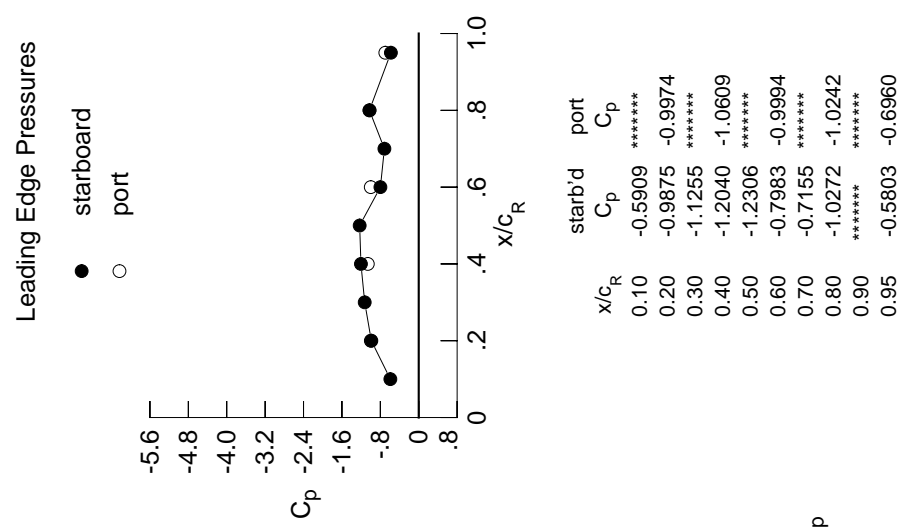

Table H4. Continued.

η	$x/c_R = .2$		$x/c_R = .4$		$x/c_R = .6$		$x/c_R = .8$		$x/c_R = .95$	
	$C_{p,u}$	$C_{p,u}$	$C_{p,u}$	$C_{p,u}$	$C_{p,u}$	$C_{p,u}$	$C_{p,u}$	$C_{p,u}$	$C_{p,u}$	$C_{p,u}$
0.050	-0.1991	-0.2213	-0.0074	*****	*****	*****	*****	*****	*****	*****
0.100	-0.2058	-0.2245	-0.0185	*****	*****	*****	*****	*****	*****	*****
0.150	-0.2169	-0.2284	-0.0347	*****	*****	*****	*****	*****	*****	*****
0.200	-0.2226	-0.2287	-0.0472	*****	*****	*****	*****	*****	*****	*****
0.250	*****	-0.2358	-0.0674	-0.3168	-0.4171	*****	*****	*****	*****	*****
0.300	-0.2470	-0.2424	-0.0876	-0.3093	-0.4179	*****	*****	*****	*****	*****
0.350	*****	-0.2596	-0.1147	-0.2950	-0.3853	*****	*****	*****	*****	*****
0.400	-0.2898	-0.2841	-0.1135	-0.2766	-0.5566	*****	*****	*****	*****	*****
0.450	-0.3124	-0.2905	-0.0890	-0.2666	-0.7076	*****	*****	*****	*****	*****
0.500	-0.3413	-0.2872	-0.1296	-0.2529	-0.7717	*****	*****	*****	*****	*****
0.525	*****	-0.2872	-0.1361	-0.2493	-0.7672	*****	*****	*****	*****	*****
0.550	-0.3695	-0.2966	-0.1367	-0.2412	-0.7634	*****	*****	*****	*****	*****
0.575	*****	-0.2964	-0.1208	-0.2460	-0.7823	*****	*****	*****	*****	*****
0.600	-0.4112	-0.2927	-0.1462	-0.2688	-0.8205	*****	*****	*****	*****	*****
0.625	*****	*****	-0.1597	-0.3309	-0.9085	*****	*****	*****	*****	*****
0.650	-0.4529	-0.3218	-0.2891	-0.4723	-1.0469	*****	*****	*****	*****	*****
0.675	*****	-0.4386	-0.5849	-0.6913	-1.1712	*****	*****	*****	*****	*****
0.700	-0.4940	-0.5299	-0.8606	-0.9005	-1.2540	*****	*****	*****	*****	*****
0.725	*****	-0.6380	*****	-1.0469	-1.0598	*****	*****	*****	*****	*****
0.750	-0.5369	-0.8204	*****	-1.0967	-0.8809	*****	*****	*****	*****	*****
0.775	*****	-0.9997	-1.0361	-1.0675	-0.7304	*****	*****	*****	*****	*****
0.800	-0.5760	-1.0861	-0.9614	-0.9975	*****	*****	*****	*****	*****	*****
0.825	*****	-1.0989	-0.9423	-0.9102	-0.5684	*****	*****	*****	*****	*****
0.850	-0.6132	-1.0838	-0.9330	-0.7676	-0.5233	*****	*****	*****	*****	*****
0.875	*****	-1.0733	-0.9255	-0.7227	-0.5102	*****	*****	*****	*****	*****
0.900	-0.8490	-1.0604	-0.8763	-0.6893	-0.5273	*****	*****	*****	*****	*****
0.925	*****	-1.0346	-0.8239	-0.6449	-0.5567	*****	*****	*****	*****	*****
0.950	-1.1577	-1.0146	-0.7777	-0.6805	-0.5115	*****	*****	*****	*****	*****
0.975	*****	-0.9938	-0.7416	-0.6056	-0.5452	*****	*****	*****	*****	*****
1.000	-0.9875	-1.2040	-0.7983	-1.0272	-0.5803	*****	*****	*****	*****	*****
-0.200	$C_{p,l}$	$C_{p,l}$	$C_{p,l}$	$C_{p,l}$	$C_{p,l}$	$C_{p,l}$	$C_{p,l}$	$C_{p,l}$	$C_{p,l}$	$C_{p,l}$
-0.400	0.2689	0.2555	0.2821	*****	-0.5641	*****	*****	*****	*****	*****
-0.600	0.2629	0.2666	0.2562	0.0859	-0.6234	*****	*****	*****	*****	*****
-0.700	0.2823	0.2704	0.2519	0.1155	-0.5956	*****	*****	*****	*****	*****
-0.800	0.3017	0.2705	0.2565	0.1367	-0.5698	*****	*****	*****	*****	*****
-0.850	0.3224	*****	0.2546	0.1573	-0.5104	*****	*****	*****	*****	*****
-0.900	*****	0.3035	0.2652	0.1692	-0.5050	*****	*****	*****	*****	*****
-0.950	*****	0.3106	0.2765	0.1883	-0.4801	*****	*****	*****	*****	*****
-0.975	0.2716	0.2788	0.2640	0.2010	-0.1649	*****	*****	*****	*****	*****
-1.000	*****	0.1831	0.1995	0.1613	-0.0713	*****	*****	*****	*****	*****
	-0.9974	-1.0609	-0.9994	-1.0242	-0.6960	*****	*****	*****	*****	*****

Medium Radius L.E.
 Run No. = 32, Point No. = 648
 $C_N = 0.568$, $C_m = -0.1037$
 $\alpha = 11.6^\circ$, $M_\infty = 0.898$
 $R_{mac} = 119.8 \times 10^6$



x/c_R	starb'd C_p	port C_p
0.10	-0.5909	*****
0.20	-0.9875	-0.9974
0.30	-1.1255	*****
0.40	-1.2040	-1.0609
0.50	-1.2306	*****
0.60	-0.7983	-0.9994
0.70	-0.7155	*****
0.80	-1.0272	-1.0242
0.90	*****	*****
0.95	-0.5803	-0.6960

Table H4. Continued.

η	$x/c_R = .2$		$x/c_R = .4$		$x/c_R = .6$		$x/c_R = .8$		$x/c_R = .95$	
	$C_{p,u}$	$C_{p,u}$	$C_{p,u}$	$C_{p,u}$	$C_{p,u}$	$C_{p,u}$	$C_{p,u}$	$C_{p,u}$	$C_{p,u}$	$C_{p,u}$
0.050	-0.2130	-0.2511	-0.0184	*****	*****	*****	*****	*****	*****	*****
0.100	-0.2173	-0.2522	-0.0287	*****	*****	*****	*****	*****	*****	*****
0.150	-0.2338	-0.2556	-0.0443	*****	*****	*****	*****	*****	*****	*****
0.200	-0.2426	-0.2556	-0.0601	*****	*****	*****	*****	*****	*****	*****
0.250	*****	-0.2632	-0.0819	-0.3434	-0.3922	*****	*****	*****	*****	*****
0.300	-0.2732	-0.2788	-0.1069	-0.3337	-0.3886	*****	*****	*****	*****	*****
0.350	*****	-0.3051	-0.1274	-0.3204	-0.3658	*****	*****	*****	*****	*****
0.400	-0.3167	-0.3019	-0.1363	-0.3032	-0.4757	*****	*****	*****	*****	*****
0.450	-0.3384	-0.3135	-0.1150	-0.2906	-0.6953	*****	*****	*****	*****	*****
0.500	-0.3676	-0.3214	-0.1429	-0.2762	-0.7837	*****	*****	*****	*****	*****
0.525	*****	-0.3249	-0.1473	-0.2782	-0.7904	*****	*****	*****	*****	*****
0.550	-0.3965	-0.3397	-0.1567	-0.2855	-0.8034	*****	*****	*****	*****	*****
0.575	*****	-0.3372	-0.1690	-0.3187	-0.8507	*****	*****	*****	*****	*****
0.600	-0.4361	-0.3234	-0.2912	-0.3927	-0.9198	*****	*****	*****	*****	*****
0.625	*****	*****	-0.4376	-0.5243	-1.0270	*****	*****	*****	*****	*****
0.650	-0.4767	-0.3090	-0.7004	-0.7161	-1.1583	*****	*****	*****	*****	*****
0.675	*****	-0.4516	-0.9228	-0.9251	-1.1230	*****	*****	*****	*****	*****
0.700	-0.5149	-0.7941	-1.0402	-1.0847	-0.9223	*****	*****	*****	*****	*****
0.725	*****	-1.0671	*****	-1.1878	-0.8632	*****	*****	*****	*****	*****
0.750	-0.5566	-1.1716	*****	-1.2112	-0.7500	*****	*****	*****	*****	*****
0.775	*****	-1.1919	-1.1165	-1.1121	-0.6606	*****	*****	*****	*****	*****
0.800	-0.6494	-1.1810	-1.0664	-0.9333	*****	*****	*****	*****	*****	*****
0.825	*****	-1.1547	-1.0541	-0.8333	-0.5814	*****	*****	*****	*****	*****
0.850	-0.9414	-1.1302	-0.9981	-0.7762	-0.5321	*****	*****	*****	*****	*****
0.875	*****	-1.1081	-0.9351	-0.7618	-0.5502	*****	*****	*****	*****	*****
0.900	-1.1134	-1.0752	-0.8925	-0.7372	-0.5843	*****	*****	*****	*****	*****
0.925	*****	-1.0459	-0.8620	-0.6692	-0.6071	*****	*****	*****	*****	*****
0.950	-1.1929	-1.0177	-0.8240	-0.7225	-0.5280	*****	*****	*****	*****	*****
0.975	*****	-0.9939	-0.7929	-0.6406	-0.5291	*****	*****	*****	*****	*****
1.000	-1.0624	-1.2389	-0.8218	-1.0240	-0.5241	*****	*****	*****	*****	*****
-0.200	$C_{p,l}$	$C_{p,l}$	$C_{p,l}$	$C_{p,l}$	$C_{p,l}$	$C_{p,l}$	$C_{p,l}$	$C_{p,l}$	$C_{p,l}$	$C_{p,l}$
-0.400	0.3023	0.2833	0.3022	*****	*****	*****	*****	*****	*****	*****
-0.600	0.2978	0.2943	0.2770	0.1034	-0.6119	*****	*****	*****	*****	*****
-0.700	0.3171	0.2983	0.2730	0.1334	-0.5837	*****	*****	*****	*****	*****
-0.800	0.3351	0.2985	0.2781	0.1549	-0.5571	*****	*****	*****	*****	*****
-0.850	0.3513	*****	0.2749	0.1761	-0.4969	*****	*****	*****	*****	*****
-0.900	*****	0.3267	0.2841	0.1868	-0.4912	*****	*****	*****	*****	*****
-0.950	0.2733	0.2831	0.2911	0.2044	-0.4637	*****	*****	*****	*****	*****
-0.975	*****	0.2718	0.2655	0.2084	-0.1538	*****	*****	*****	*****	*****
-1.000	-1.0431	-1.0879	-0.9696	-0.9328	-0.5219	*****	*****	*****	*****	*****

Medium Radius L.E.
 Run No. = 32, Point No. = 649
 $C_N = 0.631$, $C_m = -0.1143$
 $\alpha = 12.6^\circ$, $M_\infty = 0.899$
 $R_{mac} = 120.3 \times 10^6$

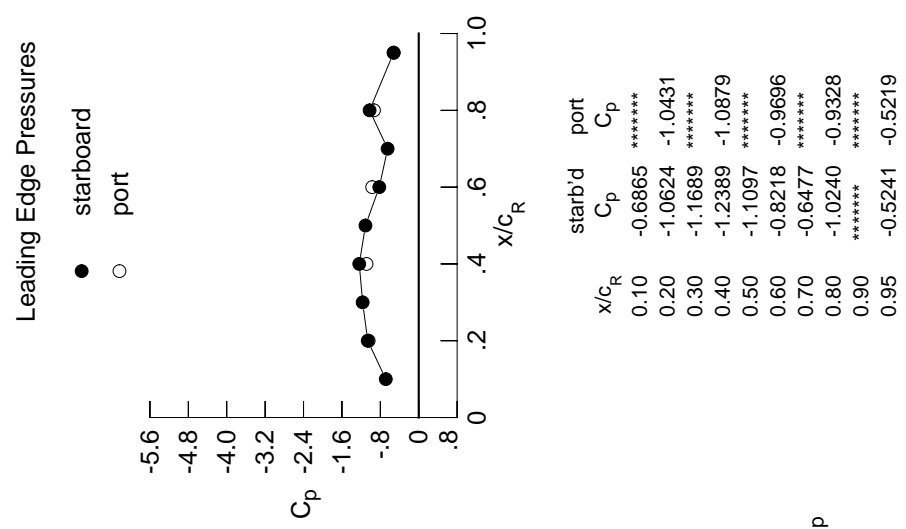

x/c_R	starb'd C_p	port C_p
0.10	-0.6865	*****
0.20	-1.0624	-1.0431
0.30	-1.1689	*****
0.40	-1.2389	-1.0879
0.50	-1.1097	*****
0.60	-0.8218	-0.9696
0.70	-0.6477	*****
0.80	-1.0240	-0.9328
0.90	*****	*****
0.95	-0.5241	-0.5219

Table H4. Continued.

η	$x/c_R = .2$		$x/c_R = .4$		$x/c_R = .6$		$x/c_R = .8$		$x/c_R = .95$	
	$C_{p,u}$	$C_{p,u}$	$C_{p,u}$	$C_{p,u}$	$C_{p,u}$	$C_{p,u}$	$C_{p,u}$	$C_{p,u}$	$C_{p,u}$	$C_{p,u}$
0.050	-0.2340	-0.2857	-0.0447	*****	*****	*****	*****	*****	*****	*****
0.100	-0.2352	-0.2868	-0.0555	*****	*****	*****	*****	*****	*****	*****
0.150	-0.2512	-0.2844	-0.0770	*****	*****	*****	*****	*****	*****	*****
0.200	-0.2664	-0.2840	-0.0888	*****	*****	*****	*****	*****	*****	*****
0.250	*****	-0.2956	-0.1212	-0.3540	-0.2996	*****	*****	*****	*****	*****
0.300	-0.3112	-0.3191	-0.1477	-0.3400	-0.3756	*****	*****	*****	*****	*****
0.350	*****	-0.3269	-0.1979	-0.3362	-0.4396	*****	*****	*****	*****	*****
0.400	-0.3465	-0.3320	-0.2373	-0.3286	-0.5067	*****	*****	*****	*****	*****
0.450	-0.3610	-0.3719	-0.2321	-0.3237	-0.6373	*****	*****	*****	*****	*****
0.500	-0.3871	-0.4218	-0.2723	-0.3258	-0.7644	*****	*****	*****	*****	*****
0.525	*****	-0.4244	-0.2910	-0.3398	-0.8162	*****	*****	*****	*****	*****
0.550	-0.4134	-0.4227	-0.3231	-0.3682	-0.8567	*****	*****	*****	*****	*****
0.575	*****	-0.4149	-0.3795	-0.4350	-0.9293	*****	*****	*****	*****	*****
0.600	-0.4484	-0.4168	-0.5462	-0.5488	-1.0152	*****	*****	*****	*****	*****
0.625	*****	*****	-0.7140	-0.7087	-1.1241	*****	*****	*****	*****	*****
0.650	-0.4712	-0.4414	-0.9230	-0.8966	-1.1481	*****	*****	*****	*****	*****
0.675	*****	-0.5725	-1.0985	-1.0733	-0.9095	*****	*****	*****	*****	*****
0.700	-0.5139	-0.8523	-1.1901	-1.2071	-0.8784	*****	*****	*****	*****	*****
0.725	*****	-1.1240	*****	-1.2700	-0.8208	*****	*****	*****	*****	*****
0.750	-0.7687	-1.2542	*****	-1.3381	-0.7298	*****	*****	*****	*****	*****
0.775	*****	-1.2604	-1.2054	-1.1402	-0.6685	*****	*****	*****	*****	*****
0.800	-1.0087	-1.2249	-1.1601	-0.9842	*****	*****	*****	*****	*****	*****
0.825	*****	-1.2038	-1.0968	-0.8565	-0.6170	*****	*****	*****	*****	*****
0.850	-1.1315	-1.1813	-1.0309	-0.7868	-0.5530	*****	*****	*****	*****	*****
0.875	*****	-1.1621	-0.9691	-0.7648	-0.5764	*****	*****	*****	*****	*****
0.900	-1.1851	-1.1329	-0.9294	-0.7465	-0.5982	*****	*****	*****	*****	*****
0.925	*****	-1.1111	-0.8965	-0.6599	-0.6105	*****	*****	*****	*****	*****
0.950	-1.1985	-1.0812	-0.8644	-0.7278	-0.5380	*****	*****	*****	*****	*****
0.975	*****	-1.0478	-0.8449	-0.6436	-0.5374	*****	*****	*****	*****	*****
1.000	-1.1243	-1.2689	-0.8583	-0.9636	-0.5144	*****	*****	*****	*****	*****
-0.200	$C_{p,l}$	$C_{p,l}$	$C_{p,l}$	$C_{p,l}$	$C_{p,l}$	$C_{p,l}$	$C_{p,l}$	$C_{p,l}$	$C_{p,l}$	$C_{p,l}$
-0.400	0.3322	0.3077	0.3189	*****	*****	*****	*****	*****	*****	*****
-0.600	0.3293	0.3180	0.2938	0.1184	-0.6015	*****	*****	*****	*****	*****
-0.700	0.3478	0.3229	0.2900	0.1470	-0.5725	*****	*****	*****	*****	*****
-0.800	0.3645	0.3234	0.2945	0.1682	-0.5463	*****	*****	*****	*****	*****
-0.850	0.3763	*****	0.2912	0.1885	-0.4861	*****	*****	*****	*****	*****
-0.900	*****	0.3465	0.2985	0.1995	-0.4793	*****	*****	*****	*****	*****
-0.950	*****	0.3418	0.3004	0.2146	-0.4501	*****	*****	*****	*****	*****
-0.975	0.2729	0.2839	0.2623	0.2078	-0.1565	*****	*****	*****	*****	*****
-1.000	*****	0.1595	0.1681	0.1423	-0.0814	*****	*****	*****	*****	*****
-1.000	-1.0808	-1.0547	-0.9972	-0.9145	-0.5776	*****	*****	*****	*****	*****

Medium Radius L.E.
 Run No. = 32, Point No. = 650
 $C_N = 0.693$, $C_m = -0.1232$
 $\alpha = 13.7^\circ$, $M_\infty = 0.900$
 $R_{mac} = 120.1 \times 10^6$

Leading Edge Pressures

● starboard
 ○ port

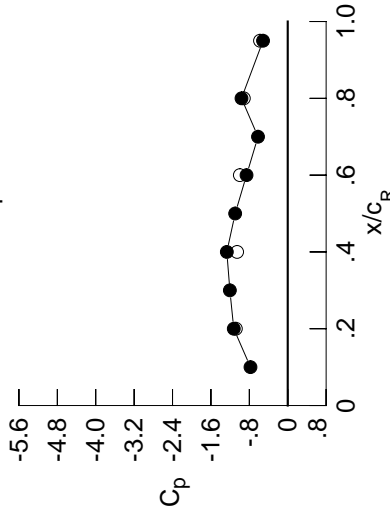

x/c_R	starb'd C_p	port C_p
0.10	-0.7758	*****
0.20	-1.1243	-1.0808
0.30	-1.2054	*****
0.40	-1.2689	-1.0547
0.50	-1.0949	*****
0.60	-0.8583	-0.9972
0.70	-0.6190	*****
0.80	-0.9636	-0.9145
0.90	*****	*****
0.95	-0.5144	-0.5776

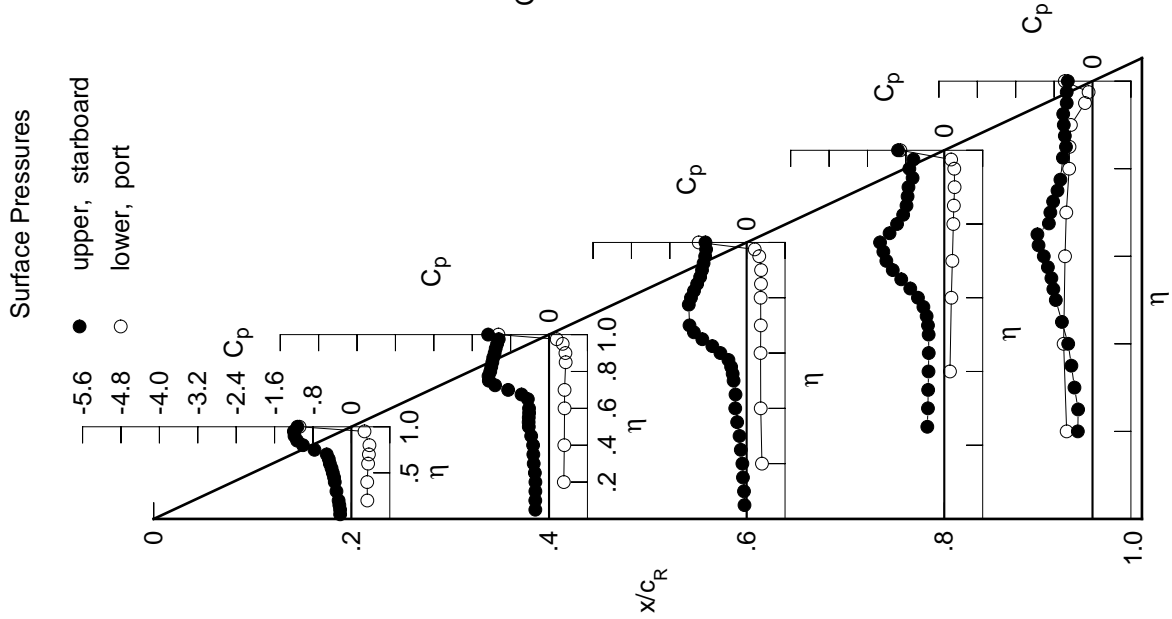
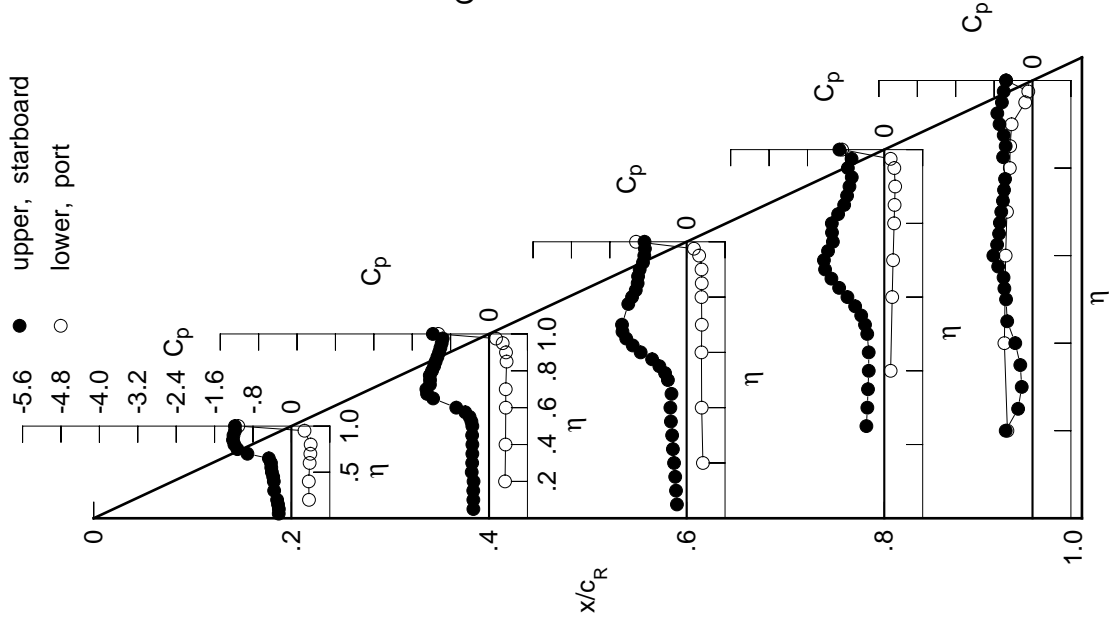

Table H4. Concluded.

η	x/c_R .2	x/c_R .4	x/c_R .6	x/c_R .8	x/c_R .95
	$C_{p,u}$	$C_{p,u}$	$C_{p,u}$	$C_{p,u}$	$C_{p,u}$
0.050	-0.2638	-0.3265	-0.2027	*****	*****
0.100	-0.2619	-0.3275	-0.2218	*****	*****
0.150	-0.2780	-0.3286	-0.2386	*****	*****
0.200	-0.2973	-0.3226	-0.2624	*****	-0.5585
0.250	*****	-0.3605	-0.2867	-0.3727	-0.3001
0.300	-0.3591	-0.3514	-0.3027	-0.3525	-0.2247
0.350	*****	-0.3476	-0.3283	-0.3390	-0.2543
0.400	-0.3667	-0.3475	-0.3395	-0.3244	-0.3588
0.450	-0.3796	-0.3517	-0.3163	-0.3244	-0.5270
0.500	-0.4061	-0.3476	-0.3904	-0.3550	-0.5512
0.525	*****	-0.3669	-0.4498	-0.4017	-0.5860
0.550	-0.4196	-0.4056	-0.5682	-0.4810	-0.6035
0.575	*****	-0.4953	-0.7196	-0.6070	-0.7154
0.600	-0.4260	-0.6826	-0.9578	-0.7680	-0.8161
0.625	*****	*****	-1.1235	-0.9408	-0.7372
0.650	-0.4695	-1.1646	-1.2588	-1.1019	-0.6964
0.675	*****	-1.2915	-1.3368	-1.2340	-0.6800
0.700	-0.9159	-1.3053	-1.3462	-1.2573	-0.6509
0.725	*****	-1.2322	*****	-1.1718	-0.6159
0.750	-1.1251	-1.2293	*****	-1.0713	-0.5933
0.775	*****	-1.2344	-1.2160	-1.0893	-0.5716
0.800	-1.1882	-1.1868	-1.1374	-1.0931	*****
0.825	*****	-1.1451	-1.1060	-0.9615	-0.6129
0.850	-1.2164	-1.1124	-1.0212	-0.8361	-0.5589
0.875	*****	-1.0756	-1.0120	-0.7750	-0.6002
0.900	-1.2065	-1.0398	-0.9786	-0.7257	-0.6876
0.925	*****	-1.0127	-0.9097	-0.6773	-0.7340
0.950	-1.1744	-0.9865	-0.8825	-0.7594	-0.6376
0.975	*****	-0.9657	-0.8694	-0.6820	-0.6000
1.000	-1.1763	-1.1705	-0.8776	-0.9351	-0.5511
	$C_{p,l}$	$C_{p,l}$	$C_{p,l}$	$C_{p,l}$	$C_{p,l}$
-0.200	0.3664	0.3336	0.3392	*****	-0.5229
-0.400	0.3622	0.3439	0.3132	0.1322	-0.5859
-0.600	0.3798	0.3484	0.3087	0.1649	-0.5602
-0.700	0.3949	0.3484	0.3151	0.1831	-0.5324
-0.800	0.4014	*****	0.3094	0.2051	-0.4728
-0.850	*****	0.3657	0.3144	0.2144	-0.4658
-0.900	*****	0.3539	0.3105	0.2264	-0.4349
-0.950	0.2728	0.2839	0.2602	0.2091	-0.1519
-0.975	*****	0.1450	0.1520	0.1316	-0.0880
-1.000	-1.1068	-1.0566	-1.0543	-0.8783	-0.5505

Surface Pressures



Medium Radius L.E.
 Run No. = 32, Point No. = 651
 $C_N = 0.753$, $C_m = -0.1312$
 $\alpha = 14.8^\circ$, $M_\infty = 0.902$
 $R_{mac} = 120.2 \times 10^6$

Leading Edge Pressures

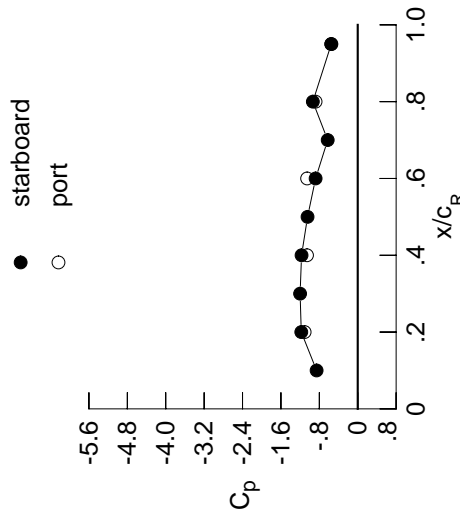

x/c_R	starb'd C_p	port C_p
0.10	-0.8568	*****
0.20	-1.1763	-1.1068
0.30	-1.2005	*****
0.40	-1.1705	-1.0566
0.50	-1.0452	*****
0.60	-0.8776	-1.0543
0.70	-0.6256	*****
0.80	-0.9351	-0.8783
0.90	*****	*****
0.95	-0.5511	-0.5505