

VEHICLE TRACKING SYSTEM USING NANOTECHNOLOGY SATELLITES AND TAGS

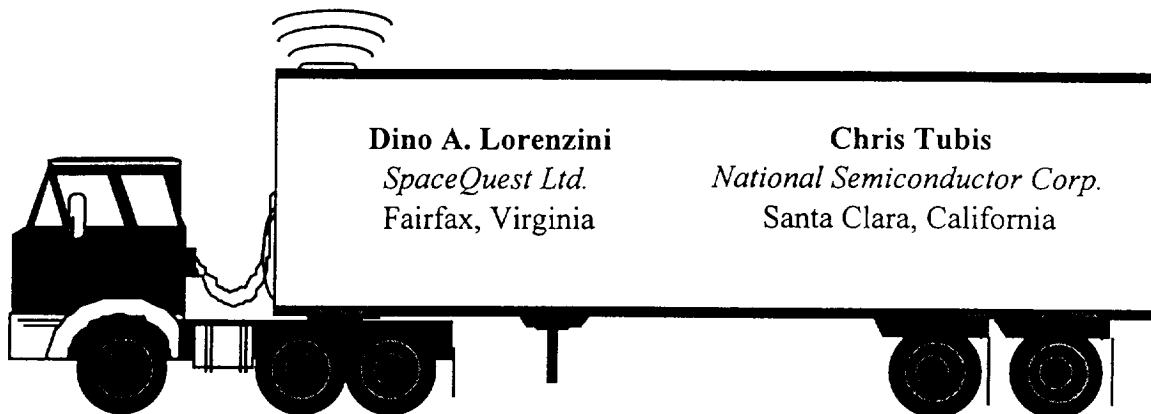

ABSTRACT

This paper describes a joint project by SpaceQuest Ltd. and National Semiconductor Corporation to design, develop and deploy a satellite-based tracking system incorporating micro-nanotechnology components. The system consists of a constellation of "Nanosats," a satellite command station and data collection sites, and a large number of low-cost electronic "tags." Two prototype Nanosats are currently under construction by SpaceQuest for launch on a Russian booster in July, 1996. The miniature tags are being developed by National Semiconductor using advanced micro-nanoelectronic components.

Both government and commercial applications are envisioned for the satellite-based tracking system. Government users are interested in keeping track of high value assets, including military hardware, trucks, containers, and high-priority shipments. Commercial users are interested in tracking the location of trailers, intermodal containers, fishing vessels, and high-value cargo. The projected low price for the tracking services is made possible by the lightweight Nanosats and inexpensive tags which use high production volume single chip transceivers and microprocessor devices.

The NanoSat structure consists of a five-inch aluminum cube with body-mounted solar panels on all six faces. A UHF turnstile antenna and a simple, spring-release separation mechanism complete the external configuration of the spacecraft. The Nanosat uses a passive, magnetic stabilization system without orbital station-keeping. High efficiency, low power consumption electronics are used to conserve the one watts of average orbital power generated by the Nanosat solar panels. Additional energy conservation features are incorporated into the microprocessor electronics.

The GaAs solar cells will average 2.4 watts of power between sunlight and eclipse. Total power consumption for all the spacecraft bus functions, including one fixed-frequency and one agile receiver, is expected to be less than one watt, leaving 1.4 watts to operate the satellite transmitter. A single transmitter with variable data rates up to 9,600 bps and adjustable levels up to 7 watts or RF power is used for polling the tags, downloading collected data, and transmitting satellite telemetry.

A V-53A microprocessor with two megabytes of random access memory serves as the communications control center and data storage device. The position information collected from the "tagged" items are stored on board the Nanosat for later transmission to a data collection site.

At a projected selling price of less than \$100, the low-cost tags being developed by National Semiconductor can be considered disposable for many applications. The high-performance, frequency-controlled, single-chip transceivers using BiCMOS technology have extremely low power consumption. High levels of silicon integration are used to achieve a low manufacturing cost at high production volumes. Computer-controlled circuits and functions keep the power consumption of the unit low so that a small, integrated, lithium battery can be used effectively for many of the intended applications.

A prototype system consisting of two Nanosats and several hundred tags should achieve its initial operational capability sometime during 1997.

1. INTRODUCTION

The idea of putting a softball-size satellite into orbit was suggested by a government client. Our previous experience with small satellite designs was the construction and launch of a 10 kg, 9-inch cube in September, 1993. This commercial Low Earth Orbit Satellite (LeoSat) has multiple receivers, modems and transmitters. Its intended purpose was to validate the feasibility of using a small, inexpensive microsatellite to communicate directly with an inexpensive tag having a low gain antenna. Several satellites of this 10 kg class are currently in orbit performing useful data communications missions.

The advantages of a reduced spacecraft size are lower cost, lower launch weight (thus, launch costs), lower power consumption, and a shorter integration and test time. Reducing the size of the satellite electronics is a straight forward process using commercial grade microelectronic components. However, the physical size of the satellite's surface area limits the amount of solar energy that can be collected with body-mounted solar panels, thus restricting the number and types of missions that can be performed by a Nanosat. Nevertheless, several specialized applications have been identified where a miniature, low power Nanosat can provide useful space communications services.

2. NANOSAT CONCEPT

Rational

Nanosats smaller than a 6-inch cube are a natural evolution to the generation of microsats that have already proven their worth in space. Small size does not necessarily translate into the equivalent of reduced capability. Used in combination for special-purpose applications, Nanosat can provide benefits well beyond their

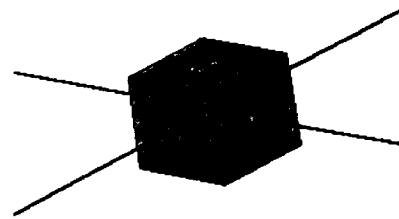

small size for specialized mission applications. Because of their relatively low cost, these space devices can be manufactured in quantity and stored for immediate launch when needed. Their small size, rigid structure, simple separation device, and lack of deployable, explosives or fuels, simplifies the task of finding a compatible piggyback launch vehicle, provided that the required orbit is not critical to mission success. Also, Nanosats can be launched in clusters of 24 or more spacecraft for a total system cost of \$10 million or less. Although Nanosats cannot do everything, they can be a cost-effective solution for filling an important niche in future space requirements for both government and commercial users.

System Architecture

Because of the low cost of producing Nanosats in quantity, and the availability of piggyback launches, it is economically feasible to tradeoff performance for quantity. For example, total system communication capacity can be achieved by launching many Nanosats, rather than only a few larger satellites. Proliferating a single orbital plane with 20 to 30 randomly-spaced Nanosats becomes a feasible alternative to using 6 to 8 Microsats with station-keeping capabilities.

Simplicity of operation, highly-specialized functions, and self-monitoring features can dramatically reduce the amount of ground command and control required to operate a Nanosat. Automated network control procedures to download mission data and upload revisions to the tag polling schedule keep operating costs to a minimum, despite the large number of Nanosats that may comprise the space segment of a satellite-based vehicle tracking system.

A typical Nanosat communications system would consist of 2 to 100 spacecraft in orbit, a Network Operations Center to coordinate all message traffic, several regional data collection sites to service international users effectively, and tens of thousands of tags distributed worldwide. A real-time data relay mode can be implemented on a region-by-region basis where both the sender and receiver are in a common Nanosat footprint (approximately 5,000 km diameter). For transferring messages globally, a store-and-forward mode can be used as illustrated in Figure 1 below. In this case, a message or data file is collected by a Nanosat and stored in the flight computer memory for later distribution to the intended receiving station. Two megabytes of on-board data storage is sufficient for most Nanosat applications.

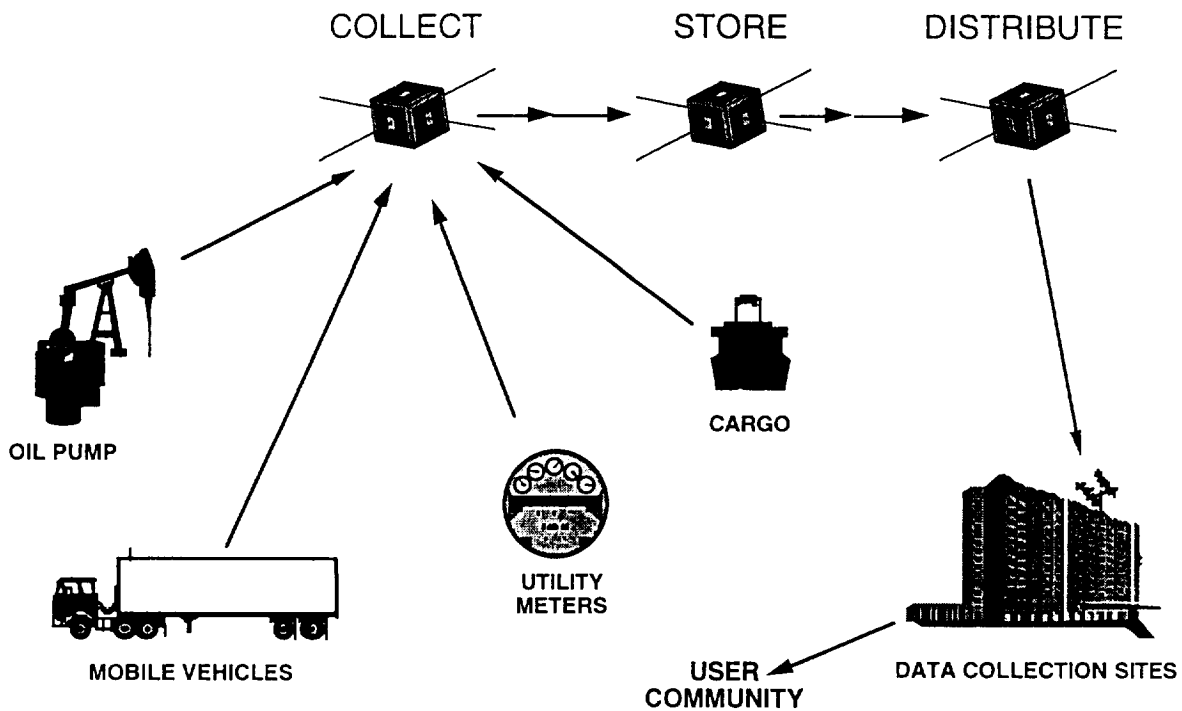

Figure 1. Nanosat Store-And-Forward Concept

3. NANOSAT APPLICATIONS

Because of the limited power available for a Nanosat transmitter, the selection of potential applications favors those that maximize the satellite’s receiver operation and minimizes the satellite’s transmitter operation. Thus, those applications where the user desires to “pick up” data from many small ground transmitters distributed worldwide, and to “deliver” that data to a few ground stations equipped with a large tracking antenna, are best suited for the use of Nanosats. Only limited polling by the satellite is needed to coordinate the tag transmission activities. Among the possible applications for Nanosats are: (1) reporting the location of mobile vehicles or high-value assets, (2) transferring critical environmental data from remote monitoring stations to a central location, and (3) reading hard-to-access gas and electric meters.

Reporting Mobile Vehicle Location



On any given day aboard ships, trains, and trucks around the world, some five million shipping containers are on the move, packed with textiles, appliances, computer parts, and every other kind of merchandise. Most shipments arrive safely, but some fall prey to the hazards that lurk between factory and market. The goods show up smashed, baked, soaking wet, or don't show up at all. Manufacturers and insurance companies try to keep tabs on shipments and protect them from harm, but it is hard to know precisely where a container is at any moment during its journey, let alone what is going on inside that container.

No one knows exactly how much cargo is lost or stolen, but in the United States alone, nearly 10 percent of all cargo shipped is lost or delayed in transit due to misrouting. Losses due to theft and vandalism account for an additional 6 to 8 percent. These problems are faced every day by transporters of all varieties of cargo. A shipping order may indicate where the ship, truck, or train is supposed to be, but how can it be certain that the container is where it should be? Was it shipped at the right time? Was it sent to the right place? Using a Nanosat tracking system, these questions are much easier to answer, by telling the user exactly where his cargo is, and what condition it is in.

By discreetly mounting a small GPS-equipped transmitter tag, a vehicle can be tracked when stolen or reported missing. Using an automatic activation scheme or satellite polling, the tag can be initialized and begin transmitting its position. It is then a simple matter to track down the missing vehicle. This system can be used by rental companies to keep track of large vehicle fleets, or by government agencies to manage their mobile resources.

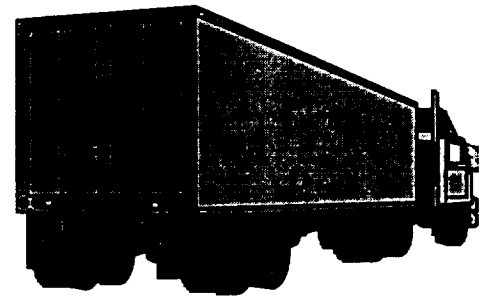

With a small electronic tag attached to each container of a shipping company's fleet, the location and status of every container can be determined at nearly any time of the day. A shipping manager can track the progress of an important shipment right on a computer screen, showing not only where the shipment is, but what its condition is, and whether it has been tampered with.

The problem of losing cargo becomes even more significant when one considers the number of vehicles that contain hazardous cargo. The safety risk posed by the loss of a toxic or flammable chemical container is much greater than the monetary loss. Tracking the location and status of hazardous materials is essential for reducing the dangers that these cargoes present.

Using a GPS receiver integrated into a mobile transmitter tag, a Nanosat system can track cargo in near-real time. If the hazardous cargo is lost, enters a high-risk area, or has its schedule interrupted, the operators know it immediately and may act to reduce the risk of an environmental disaster. Additionally, with increasing public and government concern for safer transportation of hazardous cargo, a Nanosat system can provide a solution for better risk management.

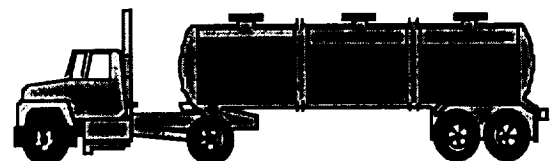

Transferring Remote Environmental Data

This application focuses on the active monitoring of natural resources and man-made facilities that affect the environment. In recent years, Federal, State, and local governments have strengthened regulations requiring the monitoring of air and water quality and pollution levels. The location of many

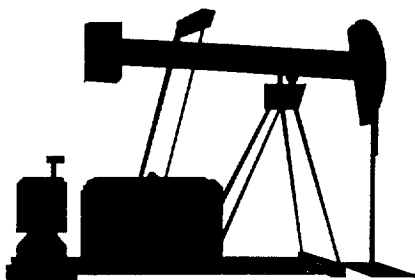

facilities prohibits constant monitoring by traditional methods. The use of remote transmitters and a Nanosat data relay system can provide an effective and cost efficient means for monitoring these facilities. For example, placing terminals along an oil or gas pipeline to measure corrosion, pressure and flow rate, or at an unmanned reservoir dam to measure water level, allows the status of the site to be relayed to a control center several times each day, providing advanced notice of impending problems.

The requirements are widespread for global environmental remote-sensing to support the scientific community. Ground and sea surface-based environmental data can be of use in understanding the nature of Earth's changing environment. The availability of distant sensing capability through the use of remotely-located tags can enhance the effectiveness of research in this area, offering wide coverage and timely data retrieval. Environmental applications suitable for a Nanosat system include monitoring such variables as:

- air or ground temperature
- atmospheric pressure
- ocean conditions
- snow pack levels
- iceberg movement
- river or reservoir level
- air or water pollution conditions
- seismic or volcanic activity
- oil spill movement

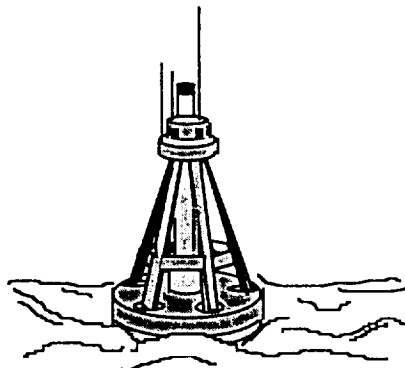

Reading Gas And Electric Meters

Another application for a Nanosat system includes the gas and electric utility industry, with a specific focus on the hard-to-access meter locations. As the world economies develop, the need for accurate and timely data and information is becoming increasingly important. Industries require communications systems which constrain cost while contributing to productivity gains.

There are approximately 120 million electric meter locations in the United States. Of these 15-20% are considered remote and hard-to-access. These meters represent the most costly metering sites for utility companies. The meters provide no information regarding the quality of service being provided to the customer, nor do they allow the utility company to detect tampering or abnormal usage patterns associated with theft of energy. In addition, the only way that traditional meters can be read or electrical service connected or disconnected is through a personal visit by a meter reader or customer service representative.

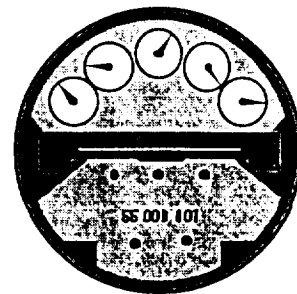

A Nanosat system can provide the means to monitor and record a large number of electrical service parameters by providing the communications network over which such information can be retrieved and communicated to any number of customers. The estimated size of the addressable U.S. metering market is approximately 17 million meters.

4. SYSTEM CONCEPT

The concept of operation for the Nanosat system is that the user contracts to receive cargo status and tracking information services for his specific application. The user is provided with a tag, which is installed at a given site or on a mobile asset. Once activated, the tags transmits information (which may include GPS determined position, local temperature, water or snow level, short messages, or any other applicable transducer output) during specific periods each day. The information is received by one or more orbiting Nanosat, and re-transmitted to one of the data collection sites for processing. The processed data is then made available to the user through a variety of electronic channels.

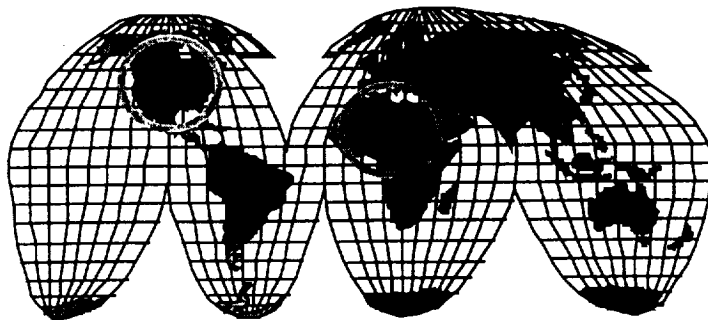

The overall Nanosat system is comprised of four interrelated segments: (1) Space Segment (Nanosat constellation), (2) User Segment (tags and user software), (3) Control Segment (command stations and data collection sites), and (4) Launch Segment (Russian booster rocket).

5. SPACE SEGMENT

Nanosat Requirements

Due to its small physical size, a Nanosat has very little area for mounting solar panels. Deployable arrays can increase the overall solar collection area, but comes at the expense of increased complexity and risk. The use of GaAs solar cells with conversion efficiencies as high as 20% will maximize the amount of power generated by the Nanosat with no loss in reliability. Because there will be insufficient solar energy generated during sunlight to power the Nanosat transmitter, a large capacity battery is needed. Only a limited amount of transmit power per day will be available and must be used judiciously to perform the required mission. A typical 800 km, circular, sun-synchronous orbit experiences a 35% eclipse cycle on every 100 minute orbit.

The small size of the Nanosat body presents certain problems for the transmit and receive antenna at lower frequencies. Operation in the UHF band or higher is desired to keep the size of the antennas within reasonable dimensions. At least one of the Nanosat receivers should use a fixed crystal frequency to insure that the satellite control center can gain access to it at all times. Power consumption of the spacecraft bus must be kept to an absolute minimum, and the transmit power must be used judiciously.

Nanosat Design Characteristics

The Nanosat is a very small “microsatellite” carefully designed and optimized for data relay with low power consumption. Excluding antennas, the satellite is a mere 5 inch cube and weighs approximately six pounds. It has an average power consumption of less than 1 watt, and uses high-efficiency GaAs solar cells to recharge the battery subsystem. Despite its small size, the Nanosat receiver is just as sensitive as satellites ten times its size. Each Nanosat has two receivers, power-agile transmitter, and two megabytes of solid-state data storage. The radios used for communications are tuned to the UHF band. A sketch of the Nanosat configuration is shown in Figure 2.

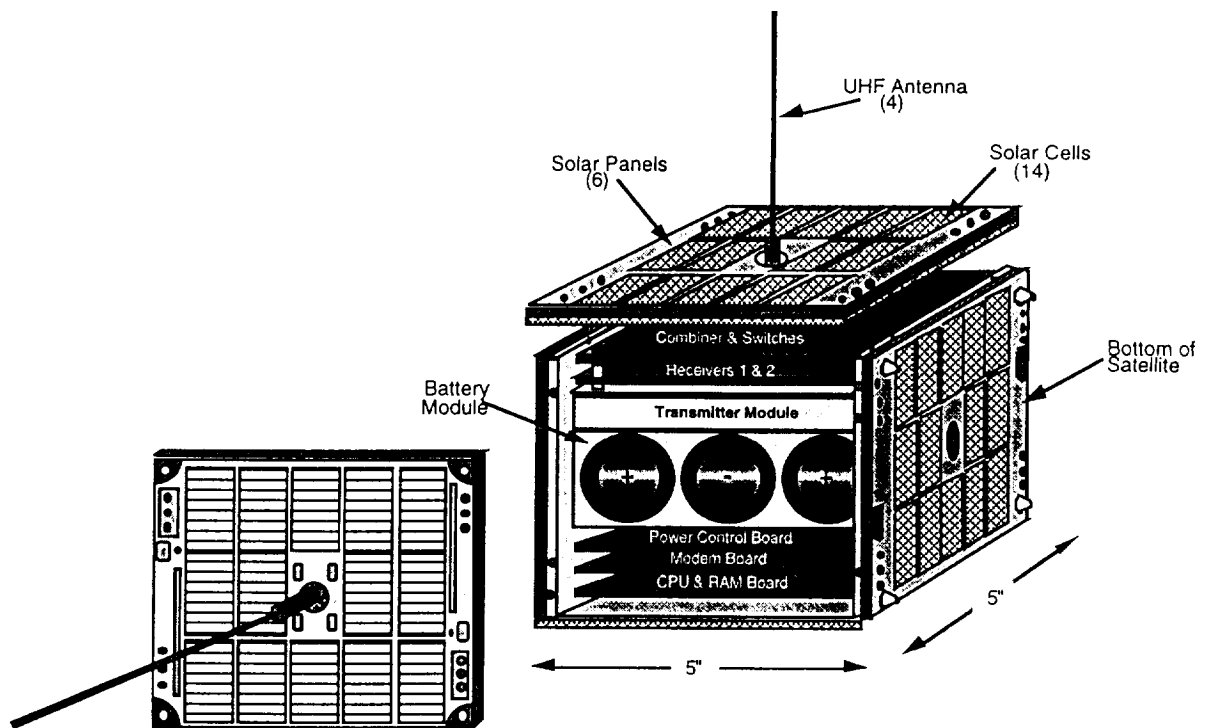

Figure 2. Nanosat Configuration

Because weight is not a significant concern, the Nanosat uses an all aluminum structure to achieve low manufacturing cost. Three F-size NiCd cells provide 6 amp-hours of battery capacity at 4.2 volts. Six multi-layer printed circuit boards with surface-mount components on both sides contain all of the essential Nanosat electronics. Board interconnection is accomplished using flexible Kapton ribbon cables.

The six interchangeable solar panels each contain two serial strings of seven 4 cm x 2 cm GaAs cells having an efficiency of 19%. Each panel produces 2.88 watts of power in sunlight. The six Nanosat panels combined will generate 3.7 watt-hours of energy during its 100 minute orbit after charging and regulation inefficiencies are considered. On a daily basis the Nanosat will collect approximately 54 watt-hours of energy. Since the entire Nanosat bus draws less than one watt continuously, this leaves 30 watt-hours of energy to operate the transmitter in a push-to-talk mode. This is sufficient to operate the Nanosat transmitter at 7 watts of RF power for at least two hours each day. Thus, a single Nanosat can send more than 15,000 polls using one hour of transmit time each day. The polls can be distributed throughout the world as needed to service mobile or fixed tags. In addition, each Nanosat can download over two megabytes of stored data to any data collection site during the remaining one hour of daily transmit time.

The Nanosat communication system consists of two high-sensitivity receivers, one agile and one set at a fixed frequency. The agile receiver also functions as a spectrum analyzer to measure the receive signal strength across a 2 MHz band. A single, power-agile transmitter operates from 1,200 to 9,600 bps. Its DC to RF efficiency is better than 50%. Its output power is software adjustable from 0.5 watt to a maximum of 7 watts. A 4-element, circularly-polarized, turnstile antenna serves for both the received and transmit functions. Each element consists of a short length of piano wire. UHF frequencies are used for both transmit and receive.

The modulation scheme is narrow-band FM, Gaussian-filtered Minimum Shift Keying (GMSK). The two demodulators can be commanded from the ground to operate at 1,200 bps or at 9,600 bps for uploading new flight software from the Network Operations Center in a single pass.

The Nanosat flight computer uses a V-53A 16-bit microprocessor which uses 3 volt logic. Two megabytes of Error Detecting And Correcting static RAM are used for both program and data storage. Additional memory can be included if required for a particular mission. The computer module also contains remote reset circuitry, an analog-to-digital converter for collecting on-board telemetry, direct memory access, and multiple serial communications controllers. The flight computer runs a real time multi-tasking kernel with application programs for polling, telemetry, housekeeping, memory management, subsystem power and functional control, and protocol implementation. A block diagram of the Nanosat electronics is shown in Figure 3.

A completely passive system consisting of a permanent magnet and four soft metal damping rods are used to stabilize the Nanosat. Using this approach, the Nanosat will align itself with the Earth's magnetic field, tumbling two times each orbit. The omni-directional antenna allows communication link closure for almost all orientations. A linear ground-based antenna accommodates both the right-hand and left-hand circularly-polarized Nanosat signals. No station-keeping mechanism is provided, nor needed for the intended applications.

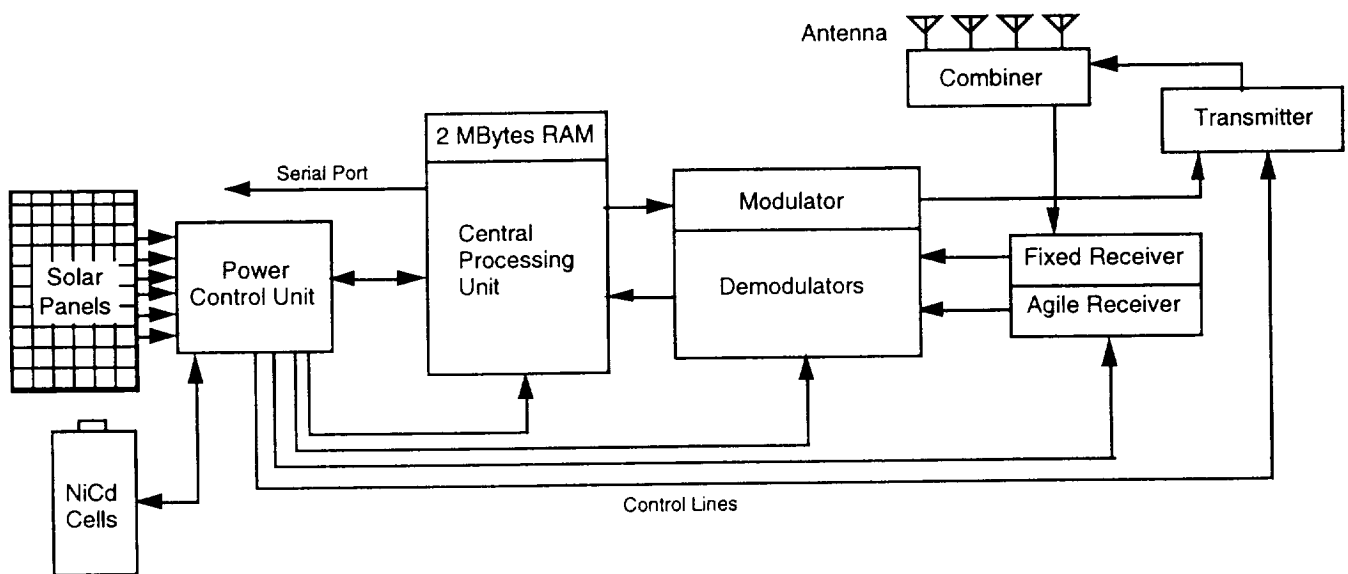

Figure 3. Block Diagram of Nanosat Electronics

6. USER SEGMENT

Tag Requirements

In order to be useful in commercial applications, the tag must be available at very low cost. A high level of functional integration along with large production quantities is necessary to drive the selling price down to levels that are attractive to mariners, shippers, researchers and environmentalists.

Besides its low cost, the tag must consume very little power so that unattended operation for several months is possible using only an internal battery. This requires extensive use of low power GaAs components, an efficient power amplifier design, and an intelligent power switching of the tag's subsystems. The smaller and lighter it is possible to manufacture the tag, the more varied applications it will be possible to address. A small size will allow it to be placed inconspicuously on many objects to be sensed or tracked. In some respects, the tag is as complex as the Nanosat itself.

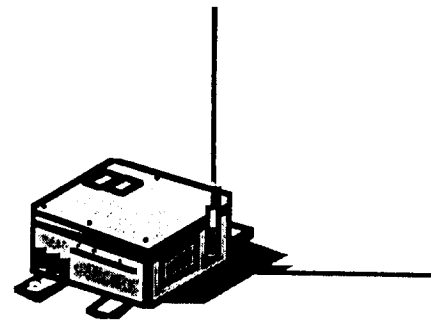

Design Features

The tag under development by National Semiconductor is a self-contained device incorporating a microprocessor, modem, transmitter, receiver, antenna, and internal battery. Its built-in software handles all functions involved in collecting, processing, and transmitting the data it is programmed to relay. The terminal receives and stores data for transmission to the orbiting Nanosats. Its compact design facilitates easy mounting to a variety of objects, including cargo containers, buoys, pipelines, and boats. The case is weatherproof and rugged, allowing it to survive in harsh environments.



Through its standard RS-232/422 interface, the terminal can be configured to receive a signal from just about any source, and store that digital data. A transducer measuring anything from barometric pressure to ultraviolet light-levels may be incorporated into the terminal. The terminal may even be configured to transmit short text messages from remote sites. The input options make the terminal extremely flexible, because its fundamental design is independent of its specific use.

Each terminal also has the ability to program its transmission cycle for a specific role. For example, the terminal may be told to transmit data packets every time a Nanosat is in view (about 10 times per day for a two satellite constellation), just once a day, or once a month, depending on the time-varying nature of its data. For terminals with both transmit and receive capabilities, data transmission may be configured to take place only when the terminal is "polled" by the satellite. Limiting the tag's transmission time permits efficient use of the tag's battery power. Computer-controlled circuits and functions keep the power consumption of the unit low so that a small, integrated, lithium battery can be used effectively for many of the intended applications.

At a projected selling price of less than \$100, the low-cost tags being developed by National Semiconductor can be considered disposable for some applications.

Low Cost Implementation

The high-performance, frequency-controlled, single-chip transceivers using BiCMOS technology have extremely low power consumption. The complete RF components will be embedded into a single multilayer ceramic module occupying an area of less than one square inch. Through the use of low temperature cofired ceramic (LTCC) technology, National Semiconductor is able to create substrate modules that integrate silicon, passive components and ceramic technology. Hundreds of passive components, including filters, are buried inside a multilayer ceramic substrate. This process enables micro-miniaturization and low cost.

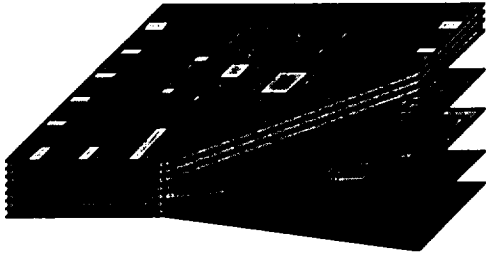

conductors, vias, components such as capacitors, resistors, couplers and filters, and other RF devices to produce a highly integrated module.

Using advanced lamination techniques and a single firing at 900°C, layers of ceramic tapes imprinted with thick-film materials are combined to form a monolithic structure. The ceramic structure built using the LTCC process contains buried

8. GROUND SEGMENT

The Nanosat ground segment consists of one or more Network Operations Centers and as many data collection sites as may be required to download user data efficiently and give major users immediate access to the data generated by their deployed tags.

Network Operations Center

The Network Operation Center is responsible for the command and control of all of the Nanosats in the space constellation. This includes making changes to on-board software, monitoring the health status of each satellite via telemetry analysis, and uploading new mission schedules as may be required to satisfy user requirements. The primary Nanosat Network Operations Center is located at SpaceQuest's Headquarters in Fairfax, Virginia. A backup Operations Center is located at National Semiconductor in Santa Clara, California.

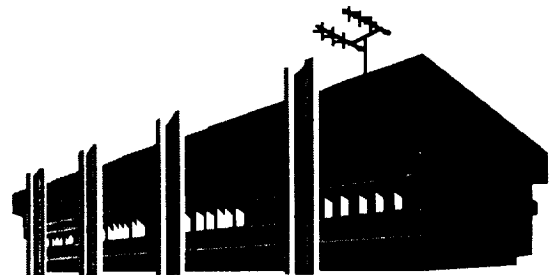

Data Collection Sites

A data collection sites consist of a state-of-the-art computer running commercial and custom software packages integrated and modified to meet unique mission requirements. These low-cost, fully-automated data collection sites can be deployed at various places around the world as may be needed by the user community. Ground station equipment for communicating with the Nanosats and downloading user data is located at each data collection site. Moreover, depending on the requirements of a particular user, a data collection site may be set up at the user's location, allowing immediate retrieval of data from the Nanosats.



Operation of the a data collection site is automatic and does not require the full-time presence of a system operator. It is ideally suited for applications where client personnel cannot be attendant. Specifically, the data collection site will download relevant tag data automatically and allow the client to retrieve his data without having to rely on an operator. The data collection sites can also be controlled remotely from SpaceQuest's Network Operations Center.

9. LAUNCH SEGMENT

The first two Nanosats will be launched into a low Earth orbit by a Russian Cosmos launch vehicle. The Nanosats will be a secondary payload on the booster during a planned launch in July, 1996 from Plesetsk Cosmodrome, Kapustin Yar, Russia.

The Cosmos booster, whose primary purpose is to deploy medium-sized satellite payloads, has completed more than 700 orbital missions with a cumulative operational reliability of 97.3%.

The current Nanosat development and launch schedule is shown in Table 1 below.

Nanosat Design & Prototypes	June 95 to Jan 96
Flight Unit Construction	Feb 96 to May 96
Integration and Testing	May 96 to June 96
Launch	July 96
System Checkout with Tags	July 96 to Sept 96
System Operation	Sept 96



Table 1. Nanosat Development Schedule

10. SUMMARY

SpaceQuest Ltd. and National Semiconductor Corp. are using nanotechnology to develop a space-based communications system that can perform several useful operational missions. The low cost and short development time needed to product the Nanosats, combined with inexpensive, low-power tags, will open up new applications which were not economically feasible with more expensive space systems.

A prototype system consisting of two Nanosats and several hundred tags should achieve its initial operational capability sometime in 1997. Vehicle tracking and monitoring will be the first applications to be addressed by this new service.

