

1
71176

MEMS TECHNOLOGY FOR SPACE APPLICATIONS

A. van den Berg, V.L. Spiering, T.S.J. Lammerink, M. Elwenspoek and P. Bergveld

MESA Research Institute, University of Twente

P.O. Box 217, 7500 AE Enschede, The Netherlands

ABSTRACT

Microtechnology enables the manufacturing of all kind of components for miniature systems or microsystems, such as sensors, pumps, valves, and channels. The integration of these components into a complete Micro Electro Mechanical System (MEMS) drastically decreases the total system volume and mass. These properties, combined with the increasing need for monitoring and control of small flows in (bio)chemical experiments, make MEMS attractive for space applications.

The level of integration and applied technology depends on the product demands and the market. The ultimate integration is process integration, which results to a one-chip system. An example of process integration is a dosing system of pump, flow sensor, micromixer, and hybrid feed back electronics to regulate the flow [1, 2]. However, for many applications a hybrid integration of components is sufficient and offers the advantages of design flexibility and even exchange of components in case of a modular set-up.

Nowadays we are working on hybrid integration of all kind of sensors (physical and chemical) and flow system modules towards a modular system: the micro Total Analysis System (μ TAS) [3, 4]. The substrate contains electrical connections as in a Printed Circuit Board (PCB) as well as fluid channels for a Circuit Channel Board (CCB) and integrated they form a Mixed Circuit Board (MCB).

1. INTRODUCTION

During the past few decades a large variety of chemical microsensors has been developed. A large amount of sensor principles such as optical, electrochemical, mass-sensitive and calorimetric have been developed [5]. However, few of these sensors have made the way to the market. One of the main reasons for this was the inherent limitation of chemical sensor performance caused by sensor drift and loss of selectivity and sensitivity. For this reason, actuators were added which enabled calibration of the sensor. Thanks to revolutionary developments in silicon microtechnology, in the last decade many so-called fluid-handling elements have been developed. Using these elements, complete so-called Micro Total Analysis Systems (μ TAS) could be built. One of the problems encountered with such systems, however, is that due to their high complexity it is virtually impossible to develop and fabricate all necessary components alone. For this reason we have developed a generic hybrid concept, a "Micro Fluidic System" (MFS) enabling the composition of a complex analysis system by integrating different components on one "motherboard" [6].

In this paper several components for such Micro Total Analysis Systems (μ TAS) will be described, such as an electrochemical microtitrator and components for fluid handling. Furthermore, the MFS concept for integration of these components into a system will be described. For an electrochemical sensor-actuator system (microtitrator) it will be shown how incorporation of this in a Micro Total Analysis System (μ TAS) improves its performance.

2. SENSOR-ACTUATOR SYSTEM

The coulometric acid/base titrator consists of an electrochemical actuator combined with an ISFET pH-sensor (see fig. 1). With this sensor-actuator device fast titrations can be carried out, and the titration time t_{end} is directly related to the acid/base concentration to be determined via the formula [7,8]:

$$\frac{\partial \sqrt{t_{end}}}{\partial C_{acid}} = \frac{F \sqrt{\pi D_{acid}}}{2 j_c}, \quad (1)$$

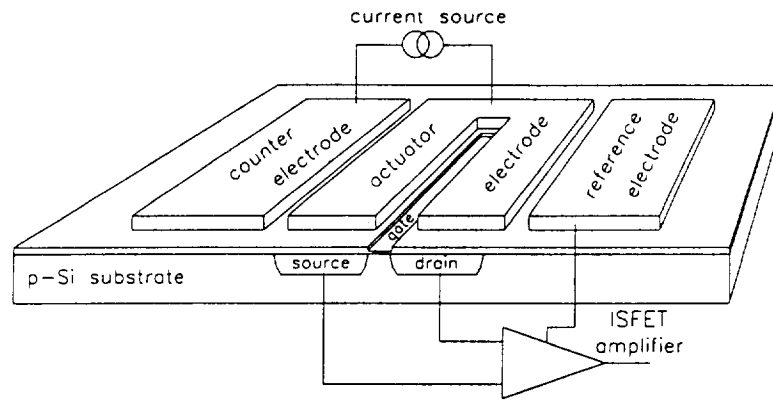

Fig. 1. Basic elements of the coulometric sensor-actuator device.

with j_c is the cathodic current density through the actuator, C_{acid} and D_{acid} respectively the concentration and diffusion coefficient of the acid and F is Faraday constant. A typical plot of the square root of t_{end} vs. the concentration of lactic acid is shown in figure 2.

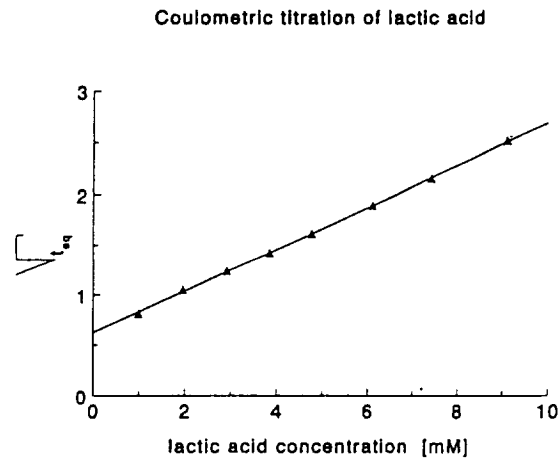

Fig. 2 Square root of t_{end} as a function of lactic acid concentration.

In practice, it appears that the coulometric actuator device, if operated as such, shows some disadvantages. First of all, there is no linear relation between titration end point and the required concentration. Secondly, the proper functioning of the device relies on the presence of only one type of mass transport: diffusion. Effects of migration may strongly influence the measurement, and to

overcome this an excess concentration of supporting electrolyte is needed. Finally the operational range is limited to a maximum of approximately 10 mM, caused by limitations in the current density. This upper limit turns out to be problematic with respect to the much higher total acid concentrations in samples such as fruit juice or wine (50 to 150 mM). The problems mentioned above can be overcome by incorporation of the microtitrator in a Micro Total Analysis System (μ TAS), where the sample solution can be diluted if necessary (see figure 3).

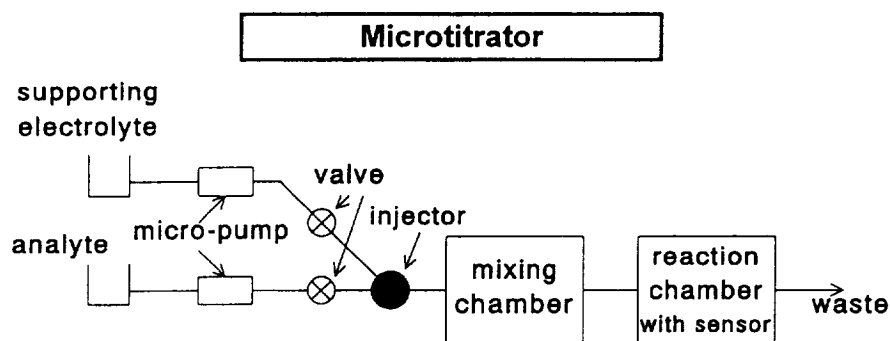

Fig. 3. The proposed μ TAS for improved coulometric sensor-actuator performance.

The μ TAS thus proposed, including subsystems, is schematically shown in figure 3. In reality the mixing and reaction chamber might be one chamber only. Also, the micro-pump itself might function as a valve.

3. COMPONENTS FOR FLUID HANDLING

For the realisation of Micro Fluidic Systems (MFS) a wide variety of components is needed. Many of them, like pumps, flow-sensors and filters, were already developed at MESA [9]. For integration in the MFS new designs have been made of a number of components that made them compatible with mentioned concept. In Fig. 4 examples are shown of a flow sensor, a resistor, a filter/mixer module, a micropump, and a microvalve specially designed for integration in MFS.

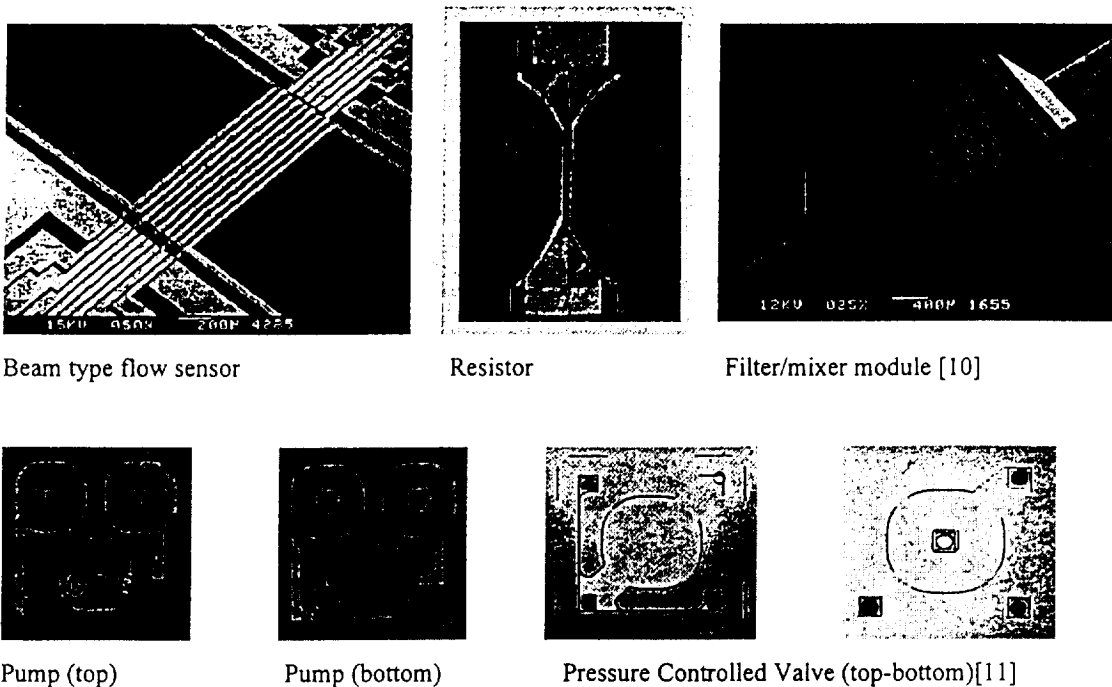

Fig. 4. Photographs of a number of different components for the Micro Fluidic System (MFS).

The integration of the abovementioned components into microsystems can be realised in two ways: hybrid and monolithic. The hybrid form will be discussed in section 4. An example of a monolithically integrated dosing system, comprising a micropump and a flow sensor, is shown in figure 5. The advantage of this type of integration is the possibility to realise very small dead volumes, which is of interest for chromatography applications.

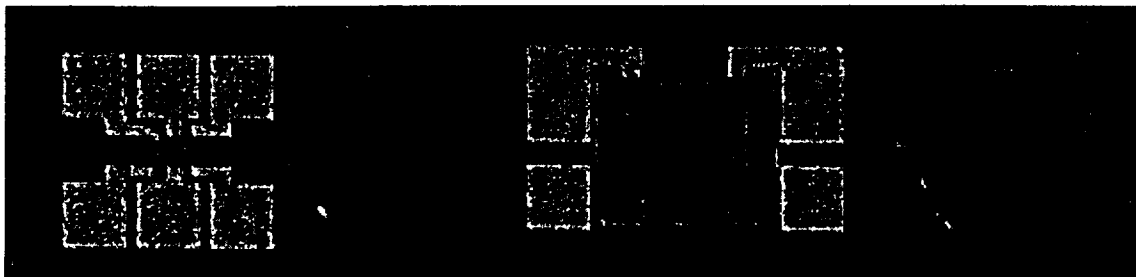

Fig. 5. Photograph of a monolithic integrated dosing system containing a pump and flow sensor.

4. MICRO FLUIDIC SYSTEM (MFS) CONCEPT

For the integration of components for fluid-handling into a system, several approaches have been proposed. Van der Schoot *et al.* [12] proposed a vertical, stackwise arrangement of components which has the advantage of efficient use of surface area but the disadvantage of being rather inflexible. An alternative was presented by Fiehn *et al.* [13], who presented a Fluidic ISFET-Microsystem (FIM) based on a planar integrated system. The main disadvantage of this system is that a whole processed glass-bonded silicon wafer is used as system substrate. Recently, an alternative was presented in which the components are at least partly, reversibly mounted in a way perpendicular to the substrate [14]. In the latter system, which uses a silicon sealing for hermeticity, the advantage is that each component can be replaced. The disadvantage is that the fabrication of the system is not easily automated.

The Micro Fluidic System (MFS) we propose is composed of a so-called Mixed Circuit Board (MCB) containing the fluid channels as well as the electronic circuitry in combination with the silicon-based fluidic components (modules). These modules have a standardised connection to the planar MCB both for fluids and electrical signals. The MCB consists of a glass-bonded silicon backplate in a first stage, whereas in the second stage (laminated) plastics are used (see fig.6). In fig. 7 an example is given of how the electrical and mechanical layout of such a microanalysis system looks like.

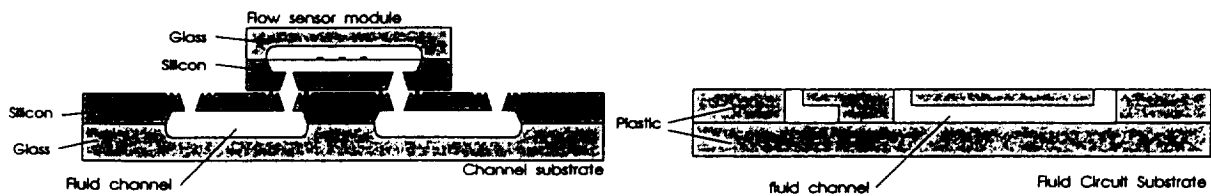

Fig. 6. Flow sensor module on Si-glass bonded substrate (left) and plastic Mixed Circuit Board (right).

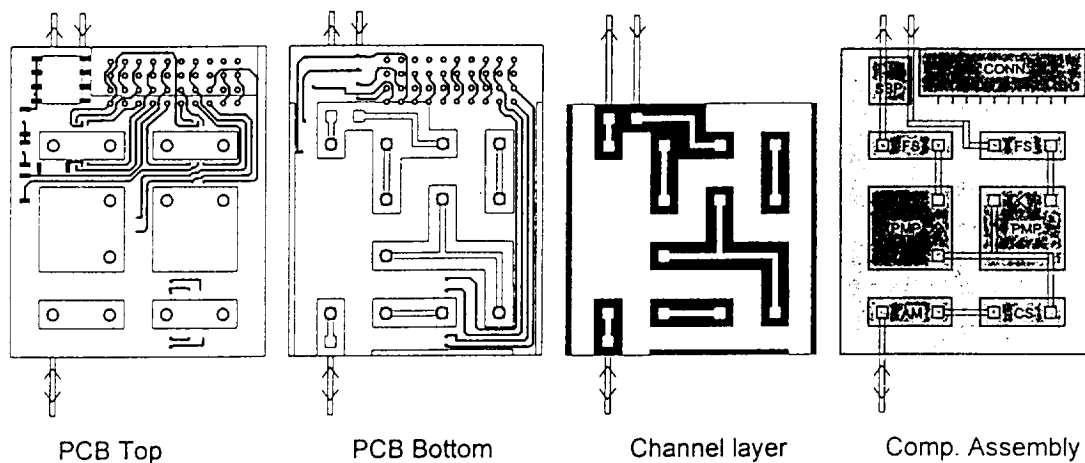

Fig. 7. Schematics of floorplan with mixed electrical and fluid connections

An example of a microanalysis system based on the MFS concept, containing two micropumps, two flow sensors and an optical detection cell is shown in figure 8. With this system, color changes of Congo red (a color indicator) upon pH changes between pH 3 and pH 9 is readily detected.



Fig.8. Micro Analysis System demonstrator comprising two pumps, flow sensors and optical detector cell.

5. CONCLUSIONS

A modular system concept for fluid handling (Micro Fluidic System, MFS) has been proposed for the realization of Micro Total Analysis Systems and micro chemical systems. MFS enables the use of standard components or modules to be integrated on a planar base plate that contains fluid channels as well as electronic circuitry. Through the standardization the exchange of different components from different suppliers is stimulated. An example of a microreactor in the form of a microtitrator is presented and it is illustrated how incorporation of this microreactor in a micro total analysis system improves its performance and avoids some of its disadvantages.

ACKNOWLEDGEMENTS

The authors want to thank Aquamarijn BV for supplying photographs of the microfilter/mixer module. The assistance of LC-Packings in the characterisation of the pressure resistance is gratefully acknowledged.

REFERENCES

- 1 H.T.G. van Lintel et al., A piezoelectric micropump based on micro-machining of silicon, *Sensors and Actuators 15*, (1988), 153-167.
- 2 T.S.J. Lammerink et al., Integrated micro-liquid dosing system, *Proc. MEMS '93, Fort Lauderdale, Florida, U.S.A., Feb. 7-10 1993*, pp. 254-259.
- 3 T.S.J. Lammerink et al., Modular concept of miniature chemical systems, *Symp. Microsystem techn. for chem. and biol. microreactors, Mainz, Germany, Feb. 20-21 1995*.
- 4 A. van den Berg, P. Bergveld, D.N. Reinhoudt, M.Elwenspoek and J.H.J Fluitman, "Miniaturized Chemical Analysis Systems", *Proc.5th Int. Symp. on Micro Machine and Human Science*", Nagoya, Japan, (1994), 181-185.
- 5 W. Göpel, J. Hesse and J.N. Zemel (ed.): "*Sensors. A comprehensive review.*", Vol. 2: Chemical and Biochemical Sensors., VCH, Meinheim, Germany, (1991).
- 6 T.S.J. Lammerink, "Micro Fluid System Concept", internal MESA report, (1994).

- 7 W. Olthuis, B.H. van der Schoot, F. Chavez and P. Bergveld, *Sensors and Actuators*, **17**, (1989), 279-283.
- 8 W. Olthuis, J. Luo, B.H. van der Schoot, P. Bergveld, M. Bos and W.E. van der Linden, *Anal. Chim. Acta*, **237**, (1990), 71-81.
- 9 J.H.J. Fluitman, A. van den Berg and T.S.J. Lammerink, in: A. van den Berg and P. Bergveld (eds.), "Micro Total Analysis Systems", Kluwer Academic Press, The Netherlands, (1994), 289-293.
- 10 C.J.M. van Rijn and M.C. Elwenspoek, Proc. MEMS '95, Amsterdam, The Netherlands, (1995), 83-87.
- 11 T.S.J. Lammerink, N.R. Tas, J.W. Berenschot, M.C. Elwenspoek and J.H.J. Fluitman, Proc. MEMS '95, Amsterdam, The Netherlands, (1995), 13-18.
- 12 B.H. van der Schoot, S. Jeanneret, A. van den Berg and N.F. de Rooij, "A Silicon Integrated Miniature Chemical Analysis System", *Sensors and Actuators*, **B6** (1992), 57-60.
- 13 H. Fiehn, S. Howitz, M.T. Pham, T. Vopel, M. Bürger and T. Wegener, in: A. van den Berg and P. Bergveld (eds.), "Micro Total Analysis Systems", Kluwer Academic Press, The Netherlands, (1994), 289-293.
- 14 R. Hintsche, M. Paeschke, A. Uhlig, C. Kruse, F. Dittrich, M.T. Pham and S. Howitz, Proc. Transducers '95, Stockholm, Sweden, (1995), 772-775.

