

*Original  
Paper*

ANALOG PROCESSING  
ASSEMBLY FOR THE  
WAKE VORTEX LIDAR  
EXPERIMENT

Edwood G. Stowe

Phil Brockman, mentor  
Internal Operations Group  
Flight Electronics Division  
Sensors Technology Branch

## Abstract

The Federal Aviation Administration (FAA) and NASA have initiated a joint study in the development of reliable means of tracking, detecting, measuring, and predicting trailing wake-vortices of commercial aircraft. Being sought is an accurate model of the wake-vortex hazard, sufficient to increase airport capacity by reducing minimum safe spacings between planes. Several means of measurement are being evaluated for application to wake-vortex detection and tracking, including Doppler RADAR (Radio Detection and Ranging) systems, 2-micron Doppler LIDAR (Light Detection And Ranging) systems, and SODAR (SOUND Detection And Ranging) systems. Of specific interest here is the lidar system, which has demonstrated numerous valuable capabilities as a vortex sensor. Aerosols entrained in the vortex flow make the wake velocity signature visible to the lidar; (the observable lidar signal is essentially a measurement of the line-of-sight velocity of the aerosols). Measurement of the occurrence of a wake vortex requires effective reception and monitoring of the beat signal which results from the frequency-offset between the transmitted pulse and the backscattered radiation. This paper discusses the mounting, analysis, troubleshooting, and possible use of an analog processing assembly designed for such an application.

## Background

### LIDAR As an Operational Vortex Sensor

CO<sub>2</sub> lidars have been used to study wake vortices since the early '70s. The basic Doppler lidar consists of a very stable single frequency laser, interferometer, transmit-receive optics, infrared detector, range-angle scanner, velocity-frequency analyzer, data-algorithm processor/display, and recorders. Aerosol particles scatter the transmitted radiation in all directions, and their motion with the atmosphere Doppler shifts the frequency from that of the transmitted pulse. The backscattered radiation is collected by optics and mixed with a small portion of the original transmitted beam. The total radiation resulting from this mix fluctuates at a beat frequency. This beat frequency is a measure of the wind velocity at that point. The Doppler lidar measures wind velocity components in the sensor line-of-sight (along the laser beam). A family of such velocity measurements produces what is called a signature of that vortex. From that signature, researchers can acquire vortex characteristics such as position and strength.

The current wake vortex lidar being developed is a pulsed solid state 2 micrometer system. In a pulsed lidar range information is provided by the two-way time of flight of light. Thus the range of the measurement is  $c/(2t)$  where  $c$  is the speed of light and  $t$  is the time from pulse initiation. The range resolution is dependent on the pulse length. The challenge of the analog processor is to measure a series of stream of data. The length of the streams is a milliseconds and the rate of the streams is dependent on the pulse rate of the lidar, typically 100 - 200 pps.

Lidar provides high-resolution velocity field measurement, and recent successful vortex measurements (Memphis & Denver, Stapleton) have demonstrated numerous other capabilities, including real-time tracking and display. The pictures below depict an example of the trailing wake vortices of a landing aircraft, the measurement geometry of a pulsed lidar system, and the spectrum signature produced from the data acquired.

Example of Measurement Geometry

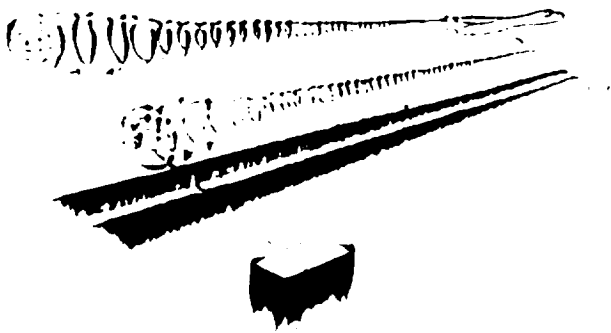

Velocity vs. Range for Single Line-of-Sight

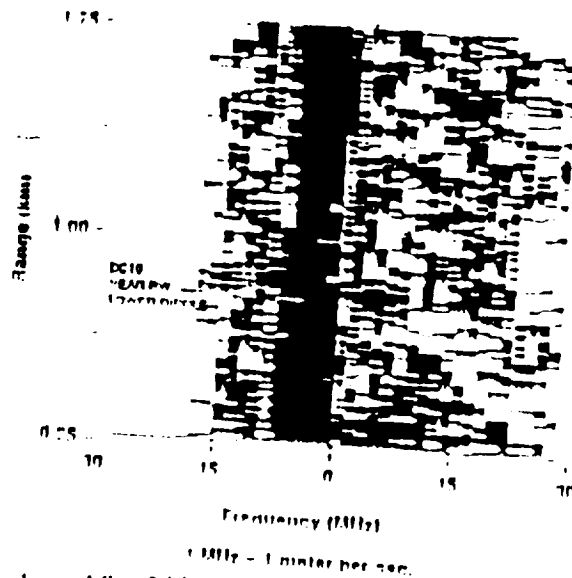

- Lidar scan produces velocity profile along each line-of-sight
- Family of velocity profiles produces characteristic signature
- Signature allows extraction of vortex strength, position, and motion

## **Research / Analysis**

For my summer internship project, I investigated an analog processing assembly that is the RF section of the data acquisition system. This assembly receives the heterodyne lidar echo output from the lidar detector/preamp and conditions the signal for input to the A/D converter. The signal occupies a bandwidth from DC to 180 MHz centered at 105 MHz with an amplitude of a few microvolts. The analog signal must be amplified, filtered, and gain-controlled using distributed stages prior to digital processing. A block diagram of the signal processor is shown on the following page. Each element is individually packaged in a small box with SMA coax signal connectors and power terminals. My first task was to mount and interconnect the individual components in a compartment, then analyze the performance of the various stages and test a signal through both the individual elements and the entire circuit. The summer research/analysis was thus divided into the following three phases: (1) Mounting of Circuit, (2) Analysis & Troubleshooting, and (3) Run Sample Data Acquisitions Using LabVIEW.

### **Circuit Description**

The analog processing assembly (schematic on following page) is an RF (Radio Frequency) circuit. It generates a 117 dB output of 200 megahertz and consists of the following elements (listed with brief function description and input impedance):

- (4) 24 dB broadband linear low-noise amplifiers
  - signal amplification; 50 $\Omega$
- (4) 3 dB fixed attenuators ("pads")
  - power level & noise reduction; 50 $\Omega$
- (1) 10 dB directional coupler
  - provides 2 output signals from one input; 50 $\Omega$
- (1) 1 dB, .5 MHz passive highpass filter
  - passes high frequencies & attenuates low frequencies;
- (1) 1 dB, 163 MHz lowpass filter
  - passes low frequencies & attenuates high frequencies;
- (1) 3 dB, 4-quadrant voltage output analog multiplier
  - generates linear product of 2 voltage inputs; 100 k $\Omega$ ||2 pf  
(schematic pictured on following page)

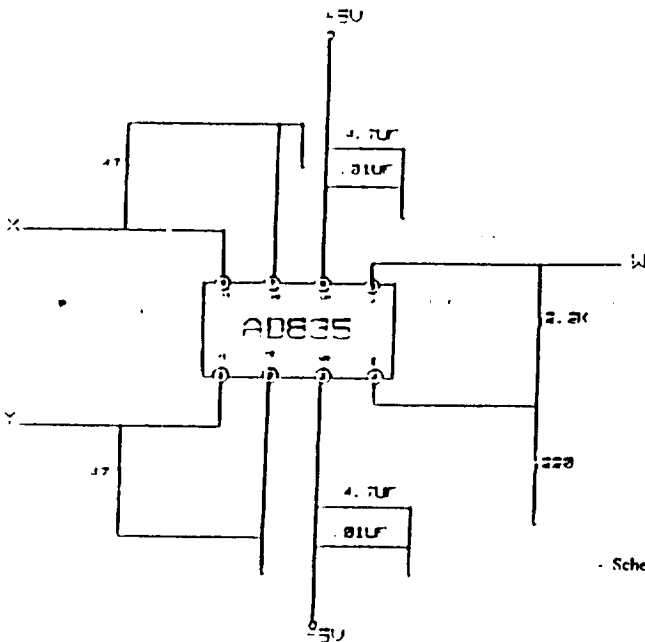
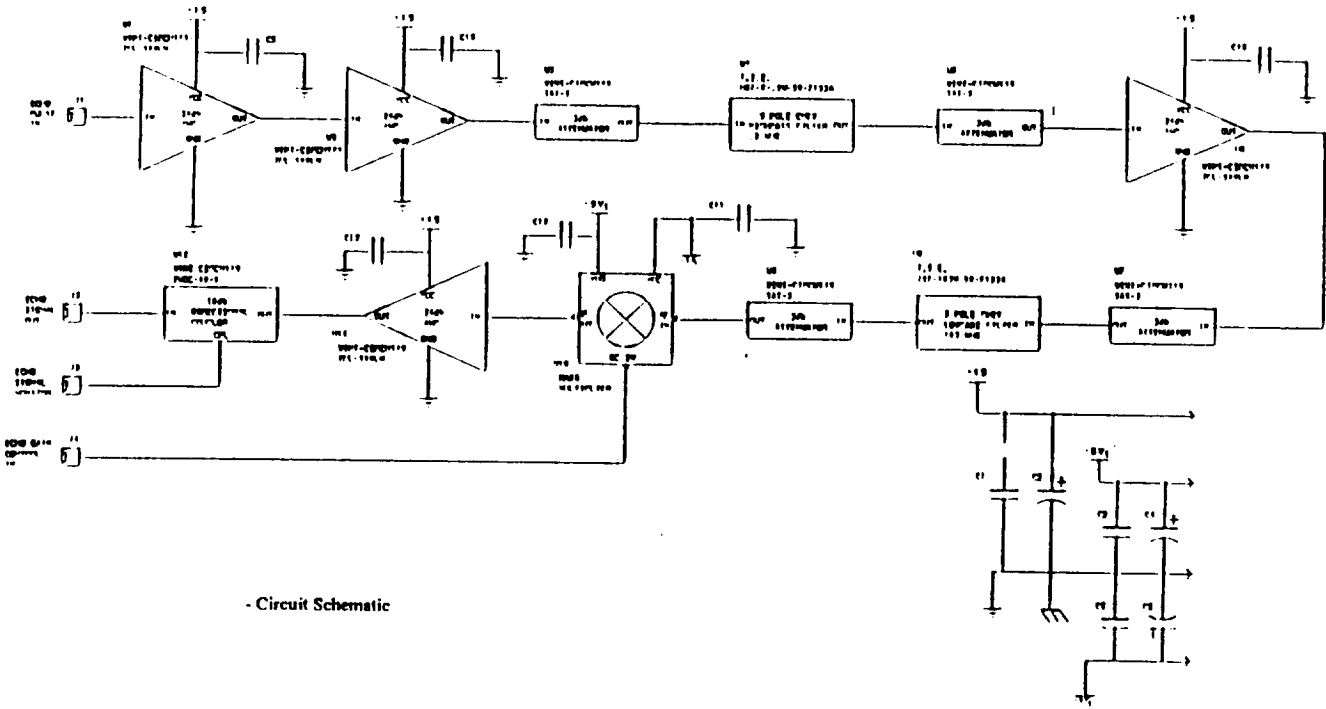

FUNCTIONAL BLOCK DIAGRAM

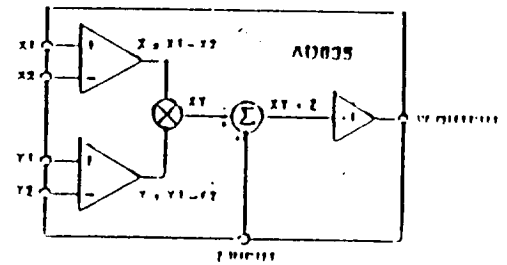

- Schematics for voltage controlled multiplier

Twelve elements make for twelve stages in the circuit. The amplifiers and multiplier are DC voltage controlled and each power line includes a capacitor to separate the ground from any DC voltage. The analog multiplier functions as a wideband amplifier; its gain/loss depends on the DC voltage, which ranges from 0 to 1 volt. The attenuators, or pads, reduce noise/power levels before and after each stage of filtration.

This circuit's *RF* response makes it susceptible to problems such as stray oscillations and noise, mainly because it deals more with amplitude modulation than frequency modulation. An amplitude-modulated signal is more prone to be disrupted by sources of random electromagnetic waves (ie. electrical machinery and electrical storms).

### Phase 1: Mounting

The schematic was designed prior to the beginning of my internship. The circuit that I mounted and analyzed this summer receives and monitors the echo pulse. It processes the echo pulse through various stages of amplification, attenuation, and filtering; the result is a signal which can be directed to an analog/digital converter or directed as input to an oscilloscope for test measurement and analysis. A 17" x 10" aluminum chassis was used for mounting the components. The initial challenge was to mount the circuit within this limited space while still leaving room for adjustment and possible modification. Every step in this phase (as with the entire project) required care and deliberation. The holes drilled in the chassis could not be misplaced, and the various elements needed to be secured to the chassis without damage. SMA cables were assembled in the lab, as were the input/output wires and connectors. All needed to be checked for impedance mismatches that might distort the signal. Care had to be taken to insure that each element, connector, and wire was grounded to the chassis and/or the power source.

After laying out the circuit within the chassis, I marked and sized the holes for securing the elements, the input, output, monitor leads, and the front panel. The holes were cut out using a drill press in the machine shop. All of the screws and washers used are brass rather than steel to insure that good contact was made with the circuit elements and the chassis. A power source filter was mounted on a smaller circuit board between the power connector and each component for the ground, +15v, +5v, and -5v sources from outside the chassis. Each wire running from the power source was "pigtailed" with a groundwire and soldered to the appropriate amplifier or the multiplier. The pigtails were crimped and the wires grounded to the chassis with internal-teeth washers under various screws. An additional input was added for the DC-gain source; this and the signal inputs/outputs were also pigtailed and grounded. For the time being, capacitors #11 and #12 were left out of the circuit until necessary; #3 - #6 may provide enough of what capacitance the circuit requires.

Finally, the entire circuit (now secured to the chassis) had to be ohmed to make certain elements were grounded to the chassis, power could reach the amps without hindrance, and impedance hadn't been added by any of the methods used to secure the circuit elements in their places. The coax cables were connected between the elements to insure there was sufficient space, and then the cover was drilled & fitted to make sure nothing prevented it from mating the chassis easily.

### Phase 2: Analysis & Troubleshooting

For my analysis, I used a Hewlett Packard Function Generator and a Tektronix 4-Channel Digital Oscilloscope, as well as 3 separate power sources to power the +15v, -5v & +5v, and the DC level for the multiplier. In order to check for impedances in the circuit, I used the Fast Fourier Transform function of the oscilloscope. FFTs allow you to transform a waveform from a display of

its amplitude vs. time to one that plots the magnitude or phase angle of the various frequencies the waveform contains with respect to those frequencies. Put simply, FFTs display the amount of signal or noise as a function of frequency within a signal.

This phase required the most investigation. I tested the circuit stage-by-stage to see how cleanly the signals went through and met with a bit of success. The signals were going through, but there were numerous artifacts and impedances that needed to be explored. I completed the stage-by-stage testing and prepared to test a signal's passage through the entire circuit. The following is a brief listing and description of the problems that were exposed and are currently being investigated.:

- Stray Oscillations
- Mysterious Artifacts
- Damaged Elements
- Too much Noise
- Insufficient Shielding
- Insufficient Attenuation

The first problem observed was a lack of constant impedance in the highpass filter, indicated by a tiny rift (1.5 dB) in the FFT waveform. Further study called for the ordering of a new filter; for the impedance change could not be compensated. Stray oscillations, noise, mysterious artifacts, and shielding came next. There were approximately 10 db of excess noise indicated by the FFT due to low level spot oscillations alone. A possible source explored was signal radiation coupling in the coax pigtail groundwires on the chassis mount SMA connectors; their length may have added impedance. I shortened these, but some oscillations remained. Another possibility was that the some coax cables were used cables, and we are building new ones. Other possibilities are insufficient shielding between input & output connectors or a damaged element.

Another problem arose when testing the multiplier for gain control. Again, there were several decibels of extra noise indicated by the FFT. In addition, the DC voltage seemed to have no effect on the noise level of the signal. The integrated circuit multiplier was found to be defective and has been replaced. Several variations of the circuit are also being investigated (ex. minus an amplifier, 6 dB pads instead of 3 dB).

There are numerous factors that could affect the complete circuit and/or the individual elements in various ways. These are to be expected in high frequency work; therefore, extreme care must be taken in design and layout. Based on my analysis, the assembly is now being modified to correct the problems detected.

### Phase 3: LabVIEW

The first phases of circuit testing were done by manually controlling the signal sources and recording the measurements by hand. To automate this process, I explored using a computer based instrument control & data acquisition program called LabVIEW. The time required to explore the signal artifacts discussed previously limited my time to apply LabVIEW to the testing; however, since part of the purpose was exposure to automated testing, I worked with the program.

LabVIEW, much like C, BASIC, or National Instruments LabWindows, is a program development application. However, while those programming systems use text-based languages to create lines of code, LabVIEW uses a graphical programming language called G to create programs in block diagram form. It relies on symbols rather than language to describe programming actions; its programs are called virtual instruments (VIs) because their appearance and operation imitate actual instruments (examples on following page). LabVIEW contains application-specific libraries for data-acquisition, GPIB and serial instrument control, data analysis, data presentation, and data storage. This is perhaps its most valuable feature - its ability to acquire data from almost any source. Various plug-in boards are available with combinations of analog, digital, and timing inputs/outputs. The hardware line also includes a wide variety of signal conditioning modules for thermocouples,

resistance temperature detectors, voltage and current inputs, and high current digital inputs/outputs. With its many features, LabVIEW adheres to the concept of modular programming. Users can divide an application into a series of tasks and continue subdividing until a complicated application becomes a series of simple subtasks. A VI can be written to accomplish each subtask and then combined with another block diagram to accomplish the larger task. The final top-level VI is a collection of subVIs representing application functions, each of which can be run separately. Debugging is easy. In essence, LabVIEW is much the conventional language, just with pictures.

The LabVIEW programming system allows researchers to sit at a terminal and communicate with a function generator and an oscilloscope. From a computer, they are able to tell the generator what signal to send out and ask the oscilloscope what signal came back. This will reduce the number of instruments that have to be read from 3 to 1. The LabVIEW front panel displays any and all information regarding the input and output signals. From there, programs can be written to manipulate the acquired data in whatever way the researchers desire. LabVIEW makes it possible to do all of this from one computer terminal.

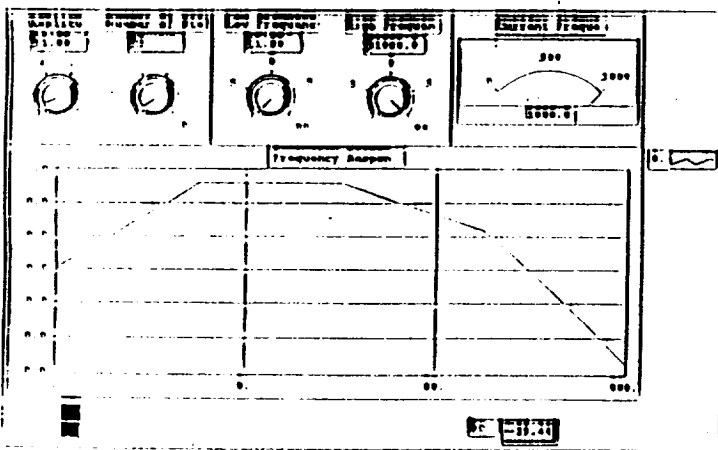

Block Diagram Display ---->

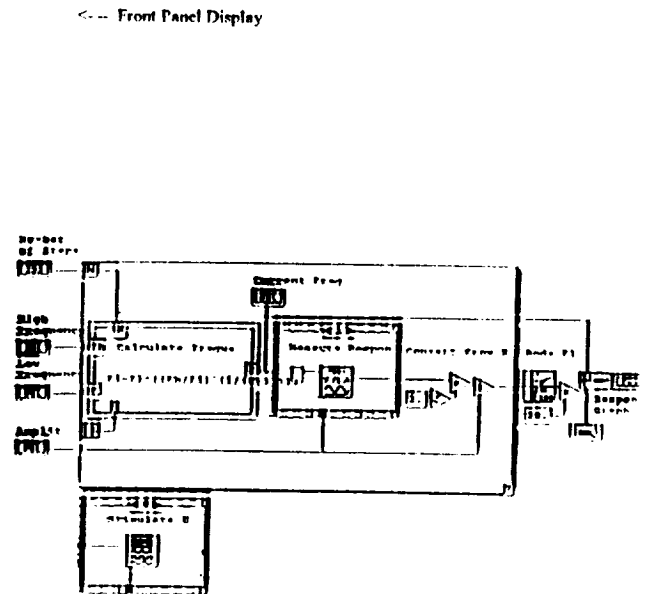

### Conclusion

The circuit was breadboarded and analyzed with indicated modifications currently being implemented. This analog processing assembly will become part of the Wake Vortex Lidar data acquisition system which will be used in field tests to measure wake vortices. Presently, researchers are developing a trailer to house various transportable "test-bed" lidar systems. Field experimentation will be run from this trailer.