

NASA/CR-1998-196709



## **Mechanical Design of High Lift Systems for High Aspect Ratio Swept Wings**

*Peter K. C. Rudolph*

*PKCR, Inc.  
13683 18th Ave. SW  
Seattle, Washington 98166*

Prepared for  
Ames Research Center  
CONTRACT A49736D(SLS)

National Aeronautics and  
Space Administration

Ames Research Center  
Moffett Field, California 93035-1000

---

**February 1998**

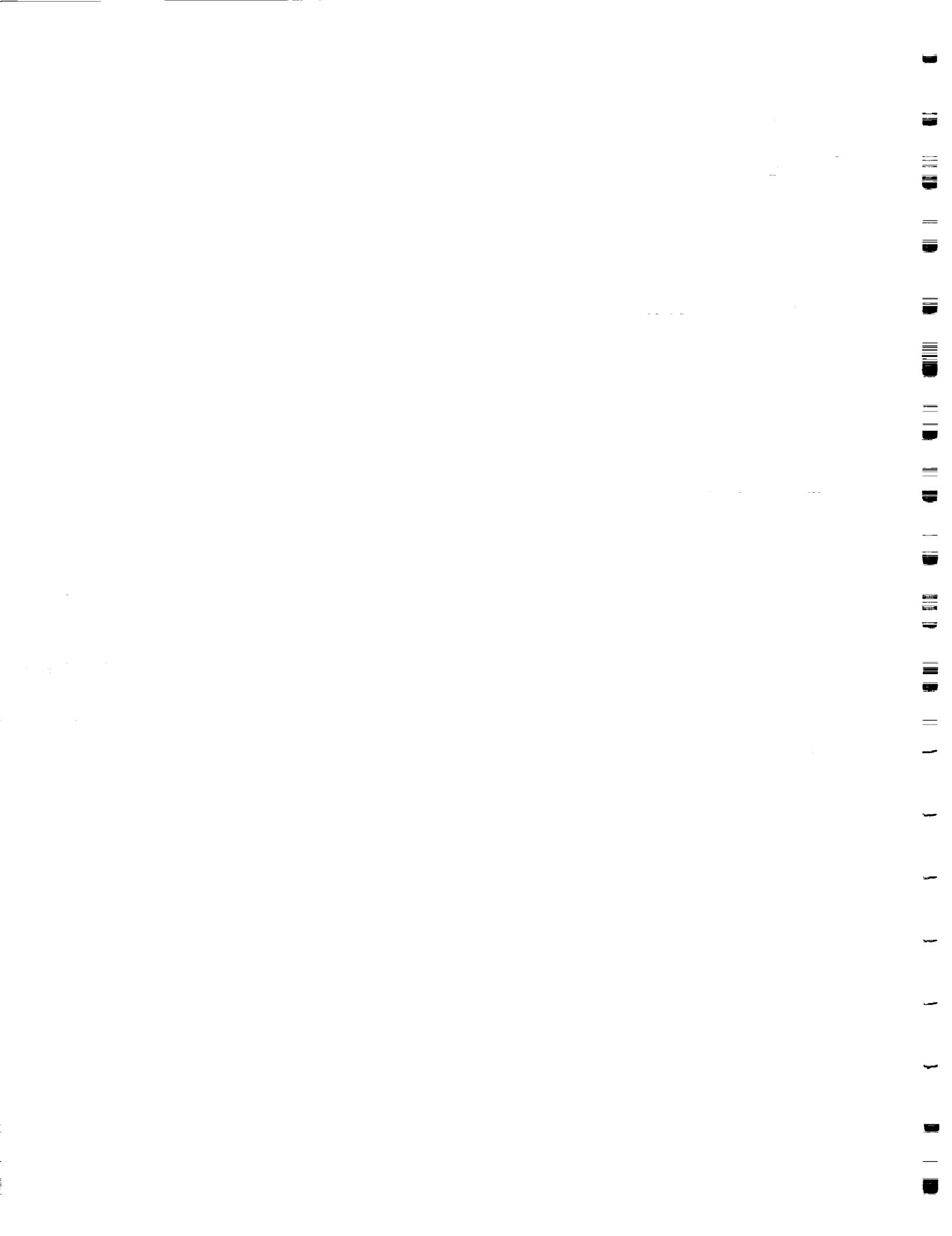

# TABLE OF CONTENTS

	Page
Summary.....	1
Part I. Design and Evaluation of Trailing Edge Flap Mechanisms .....	3
1.0 Purpose of Flap Mechanism Design Effort.....	3
2.0 Definitions and Ground Rules.....	3
3.0 Description of Mechanism Layouts.....	4
3.1 Simple Hinge.....	4
3.2 Boeing 777 Type Upside Down/Upright Four Bar Linkage.....	5
3.3 YC15 Type Upside Down Four Bar Linkage.....	6
3.4 Short Brothers Type Upside Down Four Bar Linkage .....	7
3.5 Boeing 747 SP Type Upside Down Four Bar Linkage .....	7
3.6 Airbus A330/340 Type Link/Track Mechanism.....	9
3.7 Airbus A320 Type Link/Track Mechanism.....	10
3.8 Boeing Link/Track Mechanism .....	11
3.9 Boeing 767 Type Hinged Beam Four Bar Linkage.....	13
4.0 Growth From Single Slotted to Vane/Main Double Slotted Flap.....	14
4.1 Boeing Link/Track Mechanism with End Supports for Single and Vane/Main Double Slotted Flaps.....	14
5.0 Preliminary Comparative Evaluation of Mechanism Concepts .....	15
5.1 Fowler Motion and Gap Development.....	15

5.2 Flap Spanwise Continuity .....17

5.3 Fairing Size and Number of Fairings.....17

5.4 Complexity.....18

5.5 Reliability and Maintainability .....18

5.6 Actuation Loads .....19

5.7 Weight.....19

6.0 Preliminary Down Select.....20

7.0 Conclusions and Recommendations .....21

8.0 Part I References .....22

Part I Figures.....23-55

	Page
Part II. Feasibility of a Shallow Slat.....	57
1.0 Background.....	57
2.0 Discussion.....	57
2.1 Boeing 757 Baseline Slat With Slave Links.....	57
2.2 28° Slat Without Slave Links.....	58
2.3 Slats With 20°, 15°, and 10° Maximum Deployment Angles Without Slave Links.....	58
2.3.1 Slat With 20° Maximum Deployment Angle.....	58
2.3.2 Slat With 15° Maximum Deployment Angle.....	58
2.3.3 Slat With 10° Maximum Deployment Angle.....	59
2.4 Other Configuration Options.....	59
3.0 Conclusions and Recommendations.....	59
4.0 Part II References.....	60
Part II Figures.....	61-76

1. The first part of the document discusses the importance of maintaining accurate records.

2. It is essential to ensure that all data is entered correctly and consistently.

3. Regular audits should be conducted to verify the integrity of the information.

4. Proper documentation is crucial for compliance with industry standards.

5. The following table provides a summary of the key findings from the study.

6. The results indicate a significant correlation between the variables analyzed.

7. Further research is needed to explore the underlying causes of these trends.

8. In conclusion, the data supports the hypothesis that the variables are related.

9. The findings have important implications for the field of study.

10. It is recommended that these results be used to inform future research.

11. The authors would like to thank the funding agency for their support.

12. This document is intended for internal use only and should be kept confidential.

13. For more information, please contact the research team at the following address.

14. The research was conducted over a period of six months, from January to June.

15. The data was collected from a sample of 500 participants across various demographics.

# MECHANICAL DESIGN OF HIGH LIFT SYSTEMS FOR HIGH ASPECT RATIO SWEPT WINGS

Peter K. C. Rudolph

## Summary

This report is written to satisfy requirements of 3 tasks of NASA Contract Order No. A49736D(SLS). Part I concerns trailing edge flap mechanisms, and it addresses

the requirements of Tasks 2 and 4 of the Contract. Part II concerns leading edge slat mechanisms, and it addresses the requirements of Task 1 of the Contract. The Parts are written as separate reports, each having their own numbering systems for sections, figures and references.

1. [Illegible text]

2. [Illegible text]

3. [Illegible text]



# PART I. DESIGN AND EVALUATION OF TRAILING EDGE FLAP MECHANISMS

## 1.0 Purpose of Flap Mechanization Design Effort

The NASA Ames Research Center and the aeronautical department of the University of California in Davis (U.C. Davis) are jointly working on the task of developing a methodology for the optimization and design of the high lift system for future subsonic airliners. This contractor is the third partner in this effort. His contribution is to start a mechanism design effort based on a common flap configuration. Using his past industry experience in this field, the contractor has designed seven (7) different mechanisms for the common flap configuration.

The design of a large number of flap mechanisms serves several purposes. Initially it helped to establish the boundaries for the matrix of flap positions to be used for the computational fluid dynamics (CFD) analysis. The back-to-back comparison of a variety of mechanisms using a common flap geometry allows for an early assessment of the merits of a particular mechanism and permits a preliminary down selection. The hand drawn layouts can also be used as the starting point for future computer aided design and optimization efforts.

## 2.0 Definitions and Ground Rules

There are several parameters that define the position of the flap with respect to the fixed wing. Flap deflection angle, Fowler motion, overlap and flap gap are all defined in figure 1. The wing reference plane (WRP) for the wing goes through the leading edge of the wing and the trailing edge of the flap in the stowed position, and the flap angle is the angle between the WRP in the stowed position and that in the deployed position. Fowler motion is the translation of the flap aft from the stowed position in the direction parallel to the WRP. Overlap is the distance between the leading edge of the flap and the trailing edge of the fixed wing in the direction parallel to the WRP. Overlap is positive when the flap leading edge is forward of the wing trailing edge. Flap gap is the minimum distance between the wing trailing edge and the flap upper surface for any given flap position.

A parameter that defines spanwise width of a link is called a "structural member." This unit may be 2.5

inches for the outboard flap on a smaller airplane and 5 or more inches on the inboard flap of a larger airplane.

The ground rules for the trailing edge flap part of the high lift system study are as follows:

- The basic airfoil is a three element Douglas airfoil developed under NASA sponsorship.
- The airfoil has a three position slat and a 30% chord single slotted trailing edge flap with 17.4% overlap.
- There is to be no thrust gate.
- There is to be no inboard high speed aileron.

Early in the study it was discovered that the trailing edge flap defined by Douglas does not fit into the trailing edge cove. Therefore, the flap shape was redefined to reduce the thickness of the flap, particularly up front, and to thin the blunt divergent Douglas trailing edge. The original and redefined trailing edge geometry for the basic airfoil are shown in figure 2. All layouts are based on a 100 inch wing chord.

Based on Douglas CFD analysis and test data, the maximum flap deflection angle for landing was selected at 35° with a 0% overlap and a flap gap of 1.3%. Originally the plan was to design flap mechanisms for a variety of concepts with the simple hinge, the A320 link/track mechanism and the Boeing 777 outboard flap four bar linkage excluded. These three mechanisms were to be done using computer aided design at a later date by the U.C. Davis team. However, this contractor later decided to include these three concepts in the manual design effort to give the computer aided design effort a good starting position, to allow for an early preliminary down select, and in the case of the simple hinge, to document a design approach that allows the simple hinge to deploy the flap streamwise.

When the study was initiated only hearsay information about the effect of Fowler motion on takeoff performance was available to the study team. However, at this point in the study, enough two dimensional CFD analysis is available that shows a pronounced improvement in both lift and lift to drag ratio with increased Fowler motion at typical takeoff flap angles. These tendencies are expected to hold up for the three dimensional wing and overall airplane configuration. As a result, this puts the emphasis of this study not only on simplicity, light weight, maximum lift and low drag, but also on achieving the highest possible Fowler motion at typical takeoff flap angles.

In order to assess the merits of the various flap mechanisms, a wing planform and engine location has to be assumed. The tendency in the evolution of airplanes is towards two or four wing mounted engines, single slotted flaps and no inboard high speed aileron or thrust gate. Thus, a wing planform configuration similar to the NASA Ames ASA 2150 concept, or an Airbus A320 airplane is assumed.

### 3.0 Description of Mechanism Layouts

Before going into the detailed description of the various mechanisms, a few summarizing observations are in order. The three element Douglas airfoil, which is the common airfoil for this study, is a fairly modern airfoil and shows similar geometric characteristics to the Boeing 777 or Airbus A340 airfoils. It has a thin aft end and a very pronounced aft cusp on the lower surface. This leaves less room for hiding the actuation and support systems inside the aft airfoil, as compared to some older airfoils with more thickness in the aft portion.

The flap chord is 30% of wing chord and overlap is 17.4% of wing chord, which translates into Fowler motion as the flap is deployed. This compares to a flap chord of 22% and an overlap of 9% at the inboard support of the outboard flap on the Boeing 777, or a flap chord of 28% and an overlap of 13.5% at the same location on the Airbus A320. Since the track and link lengths are roughly proportional to flap travel in any given support system, the high percentage of overlap makes the mechanism design quite a challenge, and hiding the larger actuation and support systems inside the aft airfoil is more difficult.

Seven mechanization concepts were selected to be investigated in this design study:

- Simple Hinge
- Upside Down/Upright Four Bar Linkage (two layouts)
- Upside Down Four Bar Linkages (three versions)
- Airbus A330/340 Link/Track Mechanism
- Airbus A320 Link/Track Mechanism (two layouts)
- Boeing 767 Hinged Beam Four Bar Linkage

In addition to these mechanism designs, a single layout was made to investigate the growth potential from a

single slotted flap to a vane/main double slotted flap using the Boeing Link/Track Mechanism.

Two mechanism concepts were not investigated. They are upright four bar linkages and hooked tracks. The reasons not to investigate the upright four bar linkage can be found in the reference 1 document. The upright four bar linkage just does not provide enough improvement in Fowler motion or reduction in fairing size over a simple hinge to warrant further consideration. The hooked track, even though used widely on existing airplanes, seems to be on its way out at Airbus as well as at Boeing. The reason for this is the mediocre Fowler motion progression and the in service problems stemming from highly loaded rollers on curved tracks.

For the purpose of this design study, the actuation for all but one mechanism concept was standardized to integral rotary actuators at the pivot of the drive link. This was done because the rotary actuator is permanently lubricated and has therefore become the preferred actuator for many high lift system designers and maintenance personal. The requirement that the drive shaft has to clear the spoiler actuators and the size of the rotary actuator both put significant restrictions on the location of the drive link. All mechanisms using a forward upside down drive link use the same link pivot point. This penalizes mechanisms with an upside down forward link, because a screw drive could be located below the airfoil and the upper link pivot could be moved up. With this design, more of the link would be hidden inside the airfoil. The screw drive was only pursued once in this study, but it should be remembered.

#### 3.1 Simple Hinge (Layout LO-PKCR-97-11), Figure 3

The simple hinge, with stowed flap and end positions predetermined, has only one solution for the pivot point. Since there is fairly high Fowler motion, the pivot point for the hinged flap is quite low and requires deep fittings and fairings. An increase in final deployment angle would decrease and a lesser angle increase the depth. The cusp in the aft airfoil results in a flap geometry that lets the upper surface of the flap stay in contact with the spoiler trailing edge from stowed position to almost the 30° flap position. This means that for all takeoff flap settings between 5° and 20° the flap will be sealed. However, this is probably not acceptable aerodynamically, especially since the seal is not perfect. There will be a noticeable downstream step at flaps 15° and 20°. Reshaping the forward end of the flap could be used to open up a flap gap for takeoff flap angles. However, this will thin the

flap leading edge and degrade the flap aerodynamic performance.

In conclusion, the simple hinge is unsuitable for this particular airfoil shape, flap size and flap positioning. This is in addition to the fact that the simple hinge provides by far the least Fowler motion at lower flap angles of all mechanisms considered.

With a simple hinge, it is not very difficult to visualize that a fixed vane/main flap would fare much better than the single slotted flap. Since its maximum deployment angle is higher (45 to 50°), the flap pivot would move up and make the support fairing smaller. But more importantly, the trailing edge of the vane could be made to seal against the trailing edge of the spoiler for flap angles up to about 30°, while the second gap between the vane and main flap could open up at a flap angle of about 5°. This would provide a single slot for takeoff flap settings. However, the Fowler motion at low flap angles would be slightly poorer than with the single slotted flap.

Figure 3 shows schematically a single slotted flap with a simple hinge mechanism. Several flap positions from 0 to 35° are shown. A very deep hinge support fitting is attached to the lower aft end of the wing box and provides the pivot point. A hinge fitting extends from the pivot upward. Unlike conventional hinged flaps, the flap is not mounted directly to the hinge fitting. Instead, it is connected to it by a flap fitting on the lower surface of the flap with a spherical joint in front and a small link aft. This allows streamwise and conical motion which keeps the flap hinge fairings and the flap end ribs streamwise during flap deployment.

The load path from the flap into the wing box through the pivot is very long. Making this structure wide and stiff enough to carry flap side loads would be very inefficient (high weight and fairing drag). The best approach in this configuration is probably to design the drive arm of the actuator and the drive link as "A" frames and letting them react the flap side load into the wing box. Since the two side-by-side hinge support fittings have to straddle the "A" frame type drive arm, the upper part of the support structure and fairing have to be quite wide, about equivalent to four side-by-side structural members (faired out over a longer chord). The lower part can be narrower (two structural members). The fairings around the hinge structure consist of a forward fixed fairing that attaches to the wing box and the hinge support fitting, and an aft movable fairing that attaches to the hinge fitting. The aft fairing is not attached to the flap lower surface, but there is a seal on the fairing upper

edge that allows the flap some small relative motion (flap rotation due to conical motion). The lower aft end of the aft fairing is extended to fair out the extra width of the pivot joint.

The plan view shows the flap supports for the outboard flap at about 25% from the ends. The inboard support of the inboard flap is inside the fuselage. Structurally the outboard support would be best located behind the engine strut, but this is impossible because this would put it into the engine exhaust. The support location at the inboard side of the exhaust jet is a compromise structurally, and at high speed flight it may also cause some interference drag with the engine mount strut.

The diagram on figure 3 shows that Fowler motion is almost linear with flap angle, and that there is a poor slot situation at flap angles below 30°.

### 3.2 Boeing 777 Type Upside Down/Upright Four Bar Linkage (Layout LO-PKCR-97-13 and 12), Figures 4 and 5

Figures 4 and 5 show two layouts of the four bar linkage used on the Boeing 777 outboard flaps. The figure 4 layout (LO-PKCR-97-13) is a more conservative approach of designing this four bar linkage, more in line with what Boeing did on the 777 outboard flaps. The figure 5 layout (LO-PKCR-97-12) is an attempt to improve the Fowler motion at lower flap angles for better takeoff performance. The following description applies to both figures. The differences will be explained later.

The single slotted flap is mounted to a flap fitting which is shaped as an "A" frame at its forward end so that it can react flap side loads and narrow at its aft end. The forward end, which extends downward, is attached to the lower end of the upside down forward or drive link which is also built as an "A" frame for side load reaction. The actuator is shown as a rotary hinge integrated into the drive link, and this combined link-actuator is mounted to the rear spar of the wing box. The aft end of the flap fitting is attached to the upper end of the upright aft link, and the lower end of this aft link is mounted to the aft end of two side-by-side flap support fittings. These fittings attach to the lower surface of the wing box and possibly to the rear spar. The side view does not show this, but these flap support fittings straddle the drive link and the flap fitting which are both fairly wide at their upper ends. This arrangement is approximately equivalent to the stack up of four side-by-side structural members, so the overall width of the fairing is substantial. Since the aft link does not react side loads, the structural

arrangement at this location is considerably narrower than at the front end.

The fairing around the flap support consists of a fixed forward part that is attached to the wing box and an aft fairing that is hinged on its forward end to the flap support fittings. A hinge is chosen for the aft fairing because the fairing is long and letting it just ride with the aft flap would let it drop too far down when the flaps are fully deployed. The aft fairing motion is guided by an aft fairing slave link that is hinged off the back side of the aft flap link and attaches to the aft fairing at the lower aft end. Since the aft link penetrates the upper end of the aft fairing, the top of the aft fairing has to be opened up. This is accomplished by attaching a little fairing cover plate to the aft end of the flap.

The plan views show the supports for the outboard flaps at about 25% from the flap ends. The inboard support for the inboard flap is inside the fuselage, and the outboard support again wants to be in line with the engine strut from a structural point of view. However, this is not possible because the fairing is too deep to clear the engine exhaust. So, the fairing again is inboard of the engine jet and in close proximity to the engine strut. This may cause interference drag at cruise.

The choice of using a rotary actuator integrated into the drive link affects the configuration somewhat. If the forward link was actuated by a screw jack from below the wing box, the pivot of the forward link could be moved up inside the cove, and less of it would protrude below the airfoil. However, this really would not benefit the configuration significantly since the low spot of the fairing is dictated by the aft link.

Streamwise and conical deployment with this mechanism is possible for swept outboard flaps. If the inboard drive link is taking the flap side loads, some adjustment in motion is required on the outboard support (outboard skew of the outboard mechanism).

Figure 4 (LO-PKCR-97-13) shows the more conservative four bar linkage with the flap in several intermediate positions between stowed and fully deployed. Front and aft link are essentially in a vertical position in the flap-stowed position. The initial motion pulls the flap aft and down so that a slot opens up right away. The initial slot growth is steep and then levels off. The Fowler motion progression is improved over the simple hinge. At a flap angle of  $5^\circ$  it is more than double that of the simple hinge, but at a  $20^\circ$  flap angle the improvement is only 30%.

Figure 5 (LO-PKCR-97-12) shows a more aggressive version of the upside down/upright four bar linkage with the flap in several intermediate positions between stowed and fully deployed. The objective is to increase Fowler motion at takeoff flap angles for improved lift to drag ratios, while at the same time reducing fairing depth and length. This was accomplished by reducing the length of the forward drive link, and by moving the aft link slightly aft and shortening it. As a result, link rotation angles are increased. The challenge with this change is to keep the flap from interfering with the trailing edge of the spoiler during the initial part of deployment. The effect of this change is that the flap initially goes into a slight counter clockwise rotation. Fowler motion at both  $5^\circ$  and  $20^\circ$  flap deflection for the aggressive design is significantly increased over the conservative design, and compared to the simple hinge it is almost 3.5 times the value at flaps  $5^\circ$  and 40% better at flaps  $20^\circ$ . The slot development has also changed, providing larger flap gaps at lower flap angles. The fairing length and depth are reduced over the conservative design by 4% and 14% respectively.

### 3.3 YC15 Type Upside Down Four Bar Linkage (Layout LO-PKCR-97-05), Figure 6

The YC15 four bar linkage uses two upside down links per support. The forward link is hinged to a fitting underneath the wing box and the aft link penetrates the aft cove and is hinged off a fitting on the rear spar. The flap connects to the lower ends of the links through a very long flap fitting. In order to gain more freedom in locating the aft link pivot, flap actuation was assumed to be achieved with a screw jack driving the forward link. Several iterations moving both links to different positions were tried, but an attractive solution was not found.

One possible linkage is shown in figure 6 with the flap deployed in several positions between stowed and fully deployed. The Fowler motion progression is not good, showing an almost linear relationship between aft motion and flap angle. So, it is only little better than the simple hinge. The gap progression shows an initial steep increase in flap gap, followed by a decrease, and finally another increase (S-curve). The links are quite long and the forward link dictates the depth of the fairing which is about 45% shallower than the simple hinge. The fairing is quite far forward and short which allows the aft fairing to just ride with the flap. Since the fairing protrudes only very little below the flap trailing edge when the flap is fully deployed, the outboard flap support for the inboard flap could probably be located behind the engine strut.

This would make it an aerodynamically cleaner configuration (see flap planform scheme in fig. 6).

The flap side load reaction is probably best accomplished through an "A" frame type structure on the aft link and the flap fitting since this is the shortest load path. There is no link overlap other than in the joints, so the side-by-side stack up is only the equivalent of about 2.5 structural members wide. This makes for a fairly narrow fairing.

Streamwise and conical deployment with this mechanism is possible for swept outboard flaps. If the inboard drive link is taking the flap side loads, some adjustment in motion is required on the outboard support (outboard skew of the outboard mechanism).

### **3.4 Short Brothers Type Upside Down Four Bar Linkage (Layout LO-PKCR-97-06), Figure 7**

In reference 2, another version of an upside down four bar linkage is advertised as novel and very advantageous. Both upside down links are placed below the flap. In the reference the links are all shown on cantilevered pivots, and as a result the linkage will not permit a flap side load reaction through the linkage. In the adaptation of this linkage to the study airfoil, the assumption is made that the linkage has to react side loads in some place, so the fittings are doubled up and straddle the links.

After a number of variations to the link geometry, the layout of figure 7 was developed. It shows the flap in several positions between stowed and fully deployed. Fowler motion progression is improved slightly over the conservative Boeing 777 four bar linkage and is improved over the simple hinge by 150% at 5° flaps and 39% at flaps 20°. The gap progression is an S-curve similar to the YC15, only a little more pronounced. The slot size at typical takeoff flap settings is not far away from the anticipated optimum (based on U.C. Davis data).

The major problem with this flap mechanism concept is the lateral stack up of structural members. For this layout it was assumed that the links are at the centerline of a symmetrical support system. The shortest load path for taking out flap side loads is through the forward pivot of the flap fittings into the forward link. This means that the forward link has to have an "A" frame shape. Since the support fittings straddle the forward link, they have to be spread apart and stabilized for lateral stability with tie plates. The flap fittings straddle all other support structure and also need lateral stabilizing with tie plates. In the vicinity of the aft link upper pivot, the lateral

stack up is the equivalent of 5 structural elements. This makes for a very wide fairing, which also takes a long distance to fair out.

Fairings are shown in figure 7 with a fixed front fairing attached to the wing box. The fairly long aft fairing is shown being attached to the flap, because it was not possible to find a simple slave link arrangement for a hinged aft fairing. The sudden downward motion of the flap in its initial motion creates this problem. But the aft fairing should probably be hinged to the support fittings to prevent it from extending too far down in the landing flap configuration.

The flap actuation is achieved using a rotary actuator with drive arm and drive link connecting to the forward side of the forward link. The drive links do not react side loads. Actuation could be changed to a screw jack drive into the forward link without impact on the kinematics of the mechanism.

Streamwise and conical deployment with this mechanism is possible for swept outboard flaps. If the inboard forward link is taking the flap side loads, some adjustment in motion is required on the outboard support (outboard skew of the outboard mechanism or a forward link with hinge).

The plan view shows two external supports for the outboard flap at about 25% from the flap ends. The inboard support of the inboard flap is inside the fuselage. The aft fairing on the outboard support of the inboard flap is far below the flap trailing edge when the flaps are deployed, no matter whether it is attached to the flap or hinged, and it will extend into the engine jet when arranged as an extension of the engine strut. The plan view, therefore, shows the inboard support located inboard of the engine jet but in close proximity to the engine strut. Since this fairing is wide, there may be an interference drag problem between these two fairings at cruise.

### **3.5 Boeing 747 SP Type Upside Down Four Bar Linkage (Layout LO-PKCR-97-04), Figure 8**

There is yet a third and proven way to arrange the links on an upside down four bar linkage: the Boeing 747 SP arrangement which is a pure end support. The aft airfoil section of the 747 SP wing is fairly thick, there is no cusp and the Fowler motion is not high. In addition, the links are relatively short and are entirely hidden inside the airfoil. Also, the 747 SP flaps are fairly thick and stiff and the aspect ratio is low. All of this permits a pure end

support without undue flap deflection. The end support concept is also being helped by the fact that inboard and outboard flaps do not butt together. Instead they are separated by the inboard aileron.

For a later technology airfoil with less thickness aft and higher flap aspect ratio, the pure end support is probably unacceptable, at least for the outboard flaps, because the softer and longer span flap would bend too much under the air load and close the gap. It may even be flutter prone. Two constraints imposed in this study are that there be no thrust gate and no inboard high speed aileron. Therefore, the inboard and outboard flaps are meeting at the Yehudi break, and an end support for both flaps is required at this location. This dual support may be quite wide.

Before solving the end support problem, first consider the merits of the 747 SP upside down four bar linkage with regard to flap motion. The sectional view in figure 8 shows the link arrangement and the flap in several intermediate positions between stowed and fully deployed. The upside down forward link is the drive link with a rotary actuator integrated into the pivot point. The link is hinged off a fitting on the rear spar, and the upside down aft link is hinged off the end of a support rib extending aft from the rear spar. The forward end of the flap fitting is attached to the lower end of the forward link and the aft end to the lower end of the aft link. The flap is attached directly to the flap fitting. Since both links are pointing forward in the stowed position, the initial flap motion is not only aft but has a very pronounced down component with very little rotation. This opens up a very large slot (3.7% at flap 5°). Beyond the 5° position the slot reduces gradually. There is no counter rotation in the initial flap motion. Therefore, the Fowler motion progression is a bit slow, but the gradient is steep and beyond 12° flap angle the 747 SP beats all other mechanisms considered in this study in developing Fowler motion. If one is willing to give up some Fowler motion at lower flap angles, the large initial gap can be reduced. This is accomplished by making both links longer with less link rotation. The simplicity of this four bar linkage in conjunction with its excellent Fowler motion progression and a probably acceptable gap development make it worthwhile to pursue this concept further to find acceptable solutions for the difficult double support at the Yehudi break and the possible flap bending/flutter problem on the higher aspect ratio outboard flap.

Only the aft link wipes through the flap airfoil for this linkage, and thus it will cut through the flap structure if located anywhere else but at the end of the flap.

Therefore, the aft links can only be located at the ends of the flaps. The forward link is entirely forward of the flap and therefore can be located anywhere along the span of the flap.

The first solution for designing the flap supports is shown in the wing planform on figure 8. The inboard support of the inboard flap consists of forward and aft links with the forward link reacting flap side loads. The support at the Yehudi break is a side-by-side dual support for the outboard end of the inboard flap as well as the inboard support of the outboard flap. The challenge is to make this support as small as possible and to avoid a gap between the two flap panels in the deployed positions. The support rib for the aft hinges can be a common rib for both inboard and outboard supports. The two aft links protrude down and are covered by the two fairing shells attached to the respective flaps. On the top there can be a fairing or fence extending aft from the support rib with flat side walls. This fence has the same width as the rib and aft links. As the flaps deploy, the seals at the flap ends will slide along this fairing. The flap sealing is perfect for flap angles up to 10°, and there will be only a small aft portion of the flaps gapping at flaps 20°. This means that there is very little spanwise lift discontinuity for takeoff flap settings which should provide a good lift to drag ratio at takeoff. There is a gap the width of the fairing that exists between inboard and outboard flaps, and it extends over about 1/3 of the aft end for the landing flap setting (see figure 8). The forward links for inboard and outboard flaps are hinged to fittings on the rear spar on either side of the support rib. The forward link for the inboard flap is designed with a hinge, so it does not take side loads and therefore will be narrow. The forward link for the outboard flap has to take side loads and would be designed as an "A" frame and therefore be wider.

The fairings housing the links straddle the fence. The forward part of the fairing is attached to the wing box and the aft portion to the respective flap. The outboard support of the outboard flap contains both forward link with actuator and aft link. The forward link has a hinge, is narrow, and does not react side loads. To reduce flap deflection and unwanted gap reduction, a third forward link without side load reaction is located at the mid span of the outboard flap. The number of flap support locations is three per wing. The width of the most outboard fairing is equivalent to about 2.5 structural members, the outboard mid span support 1.5 structural members, and the support at the Yehudi break as much as 5 structural members.

In order to alleviate the congestion problem at the double end supports at the Yehudi break, this support can consist only of a common aft hinge support rib, the aft links for the outboard end of the inboard flap and the aft link for the inboard support of the outboard flap. The middle portion of this support can be a fixed fairing that extends aft and forms a flat plate against which the forward part of the flaps will seal, just as described for the first support concept (fig. 8). Because there are no forward links in this common support, the width of the fairing will be significantly less and only small fairings below the flap will be required to cover the aft links in their stowed position. The remaining supports can be configured as follows:

- The forward link for the outboard support of the inboard flap is behind the engine strut, is narrow and does not react side loads.
- The inboard support for the inboard flap with both links is imbedded in the fuselage and the forward link reacts the flap side loads.
- The outboard aft link for the outboard flap is at the outboard end of the outboard flap.
- Two forward drive links for the outboard flap will be located at 25 to 30% from the flap ends. The inboard one of these two links will react flap side loads and be wider than the outboard one (similar to fig. 15).

The number of flap support fairings is 4.5 per wing, but all are small, some very small. The width of the two most outboard fairings is equivalent to about 1.5 structural members. The next one in is about 2 structural members, the fairing at the Yehudi break about 3 structural members, and the fairing behind the engine strut 1.5 structural members.

Streamwise and conical deployment with this mechanism is possible for swept outboard flaps. If the inboard drive link (forward link) is taking the flap side loads, the outboard links only have to be arranged at a slight skew angle with a hinge required in the drive link to avoid reacting side loads.

### **3.6 Airbus A330/340 Type Link/Track Mechanism (Layout LO-PKCR-97-07), Figure 9**

There are three known link/track type mechanisms that are suitable to mechanize trailing edge flaps, and one is the mechanism used on the Airbus A330/340. This type link/track mechanism was actually first invented at

Boeing in the late 1970s. The Boeing owned U.S. Patent No. 4,381,093 (ref. 3) shows that the mechanism can be used for single slotted, vane/main and main/aft double slotted flaps. The claims in this patent are inadequate and do not provide legal rights. However, the technical write up is broad and can be cited as prior art. This should make the concept available to anybody who wants to use it.

This link/track mechanism adapted to the study airfoil is shown in figure 9. The mechanism at each support location consists of a pair of straight tracks on fixed structure for the front attachment of the flap and an upright link as the aft attachment. The straight tracks and the aft link are mounted to a pair of side-by-side support beams that are attached to the lower surface of the wing box. A roller carriage with four rollers rides on the tracks, and the forward end of the flap fitting is pinned to the upper end of this roller carriage. The aft upright link is pivoted off the aft end of the support beams and the aft end of the flap fitting is pinned to the upper end of this link. The drive mechanism shown consists of a rotary actuator located in the common cove location. The drive arm from the actuator is connected to the forward end of the flap fitting with a drive link.

The configuration shown is meant to maximize Fowler motion at low flap angles. The track is sloped downward and pulls the forward end of the flap down as it starts to deploy. The aft link is sloped forward above the pivot and makes the flap aft end rotate up as the flap starts to deploy. This produces a counter clockwise flap rotation in the early phase of deployment which generates significant Fowler motion before the flap deflects downward. The Fowler motion progression is better than that of any pure linkage up to a flap deflection angle of 12°, and the gap development from this mechanism is probably the best of all mechanisms considered. The slot at flap angles of 5° to 10° is close to 2% and then slowly decreases towards full flap deployment. Judging from the CFD analysis accomplished up to this time at U.C. Davis, this is the best slot schedule possible.

Side load reaction on this concept is probably best accomplished through side load sliders on the straight tracks. This allows the rotary actuator to be in line with the drive shaft which is parallel to the rear spar or flap leading edge. With this design, there are no angle gear boxes in the drive train, but a hinge in the drive arm is required (not shown in fig. 9, but illustrated in fig. 15).

Streamwise and conical deployment with this mechanism is easy to accomplish for swept outboard flaps. If the inboard track is taking the flap side loads, the outboard

track only has to be skewed outboard a little and not be designed for side load reaction.

The fairings around the mechanism consist of a fixed forward portion, which is attached to the lower side of the wing box, and a hinged aft portion. This aft portion is rotated down with the help of a slave link between the aft side of the aft link and the aft lower end of the aft fairing. The linkage penetrates the upper surface of the aft fairing during the final stages of flap deployment. To accommodate this penetration, a piece of the upper aft fairing is used as a cover that is attached to the aft end of the flap. The flap fairing is moderately deep but quite long. The plan view shows two flap supports for the outboard flap at about 25% from the end of the flaps. The inboard support for the outboard flap is inside the side of body. From a structural point of view, the outboard support would best be an extension of the engine strut, but then the fairing would drop down into the engine exhaust when the flaps deploy. So, it is shown inboard of the engine jet in close proximity to the engine strut. As a result, it may cause an interference drag problem at high speed flight. The lateral stack up of support components is equivalent to about three structural members, so the fairing is fairly narrow.

### 3.7 Airbus A320 Type Link/Track Mechanism (Layout LO-PKCR-97-14 and 10), Figures 10 and 11

A second link/track mechanism is the one on the Airbus A320/321/319. This mechanism preceded the A330/340 mechanism, but there is similarity. It uses the same two elements as the A330/340 mechanism, namely a straight track and one link, but the arrangement is different. The link is in front of the track, it is an upside down link, and it serves as drive link. The straight track is aft and is sloped down.

This link/track concept adapted to the study airfoil is shown in figures 10 and 11. The configuration of figure 10 is a more conservative arrangement, similar to the Airbus A320, with two spanwise supports for the outboard flap at about 25% from the flap ends located below the wing. The inboard flap has one inboard support buried inside the fuselage and an outboard underneath support inboard of the engine strut. The configuration of figure 11 uses end supports for both the inboard and outboard flaps. The end support at the Yehudi break is a dual support which provides the outboard support for the inboard flap and the inboard support for the outboard flap. The outboard flap has an additional mid-span support with a drive link only.

The motion and gap characteristics for both variations are similar. Therefore, the following description applies to figures 10 and 11. The forward link is tilted forward in the stowed position and the straight track is sloped downward. During initial deployment the downward motion of the drive link overpowers the downward motion from the track which makes the flap start with a slight counter clockwise rotation as it starts to move aft. Also, the flap moves down as it moves aft and creates a significant flap gap at low flap deflection angles. The Fowler motion and gap progression of both configurations are almost identical and are very good. It is, so far, the best of all concepts considered and has only a slight shortfall to the 747 SP upside down four bar linkage at flap angles above 9°.

The air load resultant on a single slotted flap is generally close to 32% of flap chord for most flap positions except for the fully stowed position. Since the aft pivot point of the flap is close to 30% of flap chord and travels with the flap, the overturning moment from the air load is quite low. Hence, the actuation power requirements are very low.

Figure 10 shows the conservative configuration with two supports underneath the wing. The flap is attached to a flap fitting that extends forward and down. The forward end of this flap fitting is attached to the lower end of the drive link which has a rotary actuator integrated into the pivot point. The actuator is attached to a fitting mounted off the wing rear spar. There are two side-by-side support beams tied together with tie plates, and these support beams are attached to the lower aft surface of the wing box. The two side-by-side straight tracks are attached to the aft upper edges of these support beams. A roller carriage with four rollers (shown) rides in these tracks. The flap fitting is attached to this roller carriage at about the 30% flap chord location with a pinned joint. The lateral stack up of parts is about equivalent to 3.5 structural members. Side load reaction is preferably done through the track. The drive link could also be used for side load reaction, but this would probably result in a wider stack up.

Streamwise and conical deployment with this mechanism is easy to accomplish for swept outboard flaps. If the inboard track is taking the flap side loads, the outboard track only has to be skewed outboard a little and not be designed for side load reaction.

The fairings consist of a fixed forward fairing attached to the wing box and an aft fairing that is hinged to the support beams. This aft fairing rotates down as the flap deploys. The slave link for the aft fairing rotation is



mounted to an aft extension of the flap fitting and attaches to the lower aft end of the aft fairing. The flap fairing is of medium depth, but it is quite long. The outboard support of the inboard flap is close to the engine mount strut and may cause interference drag with the engine strut at high speed flight. The number of flap fairings is 3 per wing.

The A320 link/track mechanism has one characteristic that it shares only with the Boeing link/track mechanism (following section). The structure for the forward link and the aft support can be made independent of each other. With two spanwise supports and two independent attachment points per support, the flap panel has four independent fixities which is one more than required for being statically determinate. With one spare attachment point available, the system is redundant without fail-safe design practices. So the fail-safe practices for this concept can be relaxed (not necessarily completely abandoned) which may yield some savings in weight and complexity. Also, the feature of having independent structural members for the forward and aft flap attachments makes it possible for the attachments to be at separate spanwise locations

Figure 11 shows an alternate design concept for the A320 link/track mechanism with flap end supports. This approach looks very attractive since the size, especially depth and length of the support fairings, can be greatly reduced. The flap motion of this end supported concept is almost identical to the conservative approach with the supports now being underneath the flap.

For the end supported version, the straight track is moved up as far as possible to be partially hidden in the aft end of the airfoil. The depth of the track is increased, and there is only one roller riding in it. The roller is attached to the end rib of the flap, and it could be replaced by a slide block for better wear characteristics. The forward drive link is very similar in geometry to the drive link in the conservative approach of figure 10. Flap side load reaction is again preferably through the track.

Since the outboard flap has too large a span for end supports only, a third drive link is shown in the middle of the outboard flap. It is assumed that the inboard flap is stiff enough to get by with the two end supports only. So, there are three support fairings per wing. The middle one, which only houses the drive link, is very short and narrow (equivalent to 1.5 side-by-side structural members). The outboard support of the outboard flap is the next larger in size. It houses a track support beam, a track and a forward drive link (2.5 structural members). The joint support for the inboard and outboard flaps at

the Yehudi break is the widest fairing and contains a track support beam, two tracks and two forward drive links (about equivalent to 4 structural members). The inboard support of the inboard flap is assumed to be buried in the side of body and reacts side loads. All three fairings each consist of two parts. The forward fairing is attached to the wing box, and the aft fairing is attached to the flap and rides with it. It is not completely clear how the sealing between the inboard and outboard flaps can best be accomplished. One way is to let the aft fairing be the seal. In order to keep the fairing from becoming a structural member that ties the two flaps together, the aft fairing could be split along the line of the Yehudi break with a seal along the split line.

A different arrangement of the supports is possible. Since the links and tracks do not need to be co-located, the end supports could just house the tracks. The forward drive links for the outboard flap would be located about 25 to 30% from the flap ends in separate fairings. Of the two drive links for the inboard flap, one would be inside the fuselage and the other in a small fairing in line with the engine strut. This would make 4.5 fairings per wing, but all of these fairings would be much narrower. A wing planform with this kind of support scheme is shown in figure 15.

### **3.8 Boeing Link/Track Mechanism (Layout LO-PKCR-97-08 and 09), Figures 12 and 13**

This third link/track mechanism was invented at Boeing around the year 1980. U.S. Patents No. 4,434,959 and 4,669,687 and a Re-issue 32,907 (refs. 4, 5, & 6) describe the various variations and applications in much detail. These patents can be considered as prior art. However, since Boeing stopped paying the annual maintenance fees for these patents around 1994, they are expired and possibly can be used without paying royalties.

The Boeing link/track mechanism looks very much like the Airbus A320 link/track mechanism with both having an upside down forward drive link and a straight aft track at each support location. The track on the A320 mechanism is mounted to fixed structure, but the track on the Boeing mechanism is attached to the flap and travels with it. Therefore, the roller, roller carriage or slide block for the Boeing mechanism are hinged on fixed structure with no translation.

The concept adapted to the study airfoil is shown in figures 12 and 13. The configuration of figure 12 is a more conservative arrangement with the supports underneath the airfoil. The supports for the outboard flap

are located about 25% from the flap ends. For the inboard flap, the inboard support is inside the fuselage and the outboard support is inboard of the engine mount strut. The configuration of figure 13 uses end supports for both the inboard and outboard flaps. The end support at the Yehudi break is a dual support, providing the inboard support for the outboard flap and the outboard support for the inboard flap. The outboard flap has an additional mid-span support with a drive link only.

These two variations of the link/track mechanism are shown in figures 12 and 13. The characteristics of each are very similar, so the following description applies to both. The forward upside down drive link is tilted forward in the stowed position, and the straight aft track has a slight downward slope. During initial deployment the downward motion of the drive link overpowers the downward motion from the track which makes the flap start a counter clockwise rotation as it starts to move aft. Since the aft end of the flap kicks up, the flap stays in close proximity to the spoiler trailing edge, and the slot at small flap deflection angles is small. However, the Fowler motion at small deflection angles is higher than on any other mechanism.

Like the A320 link/track mechanism, the Boeing link/track mechanism can be designed to provide two structurally independent load paths per support. With two support locations per flap, there are four independent structural fixities which is one more than required. This again allows a relaxation in the fail-safe practices for this concept which may yield some savings in weight and complexity.

The conservative configuration with the supports underneath the airfoil is shown in figure 12. The flap is attached to a flap carriage fitting with a spherical joint at the flap front spar and a short link at the rear spar. Attached to the aft end and the outside of this fitting are two straight tracks. The forward end of this fitting is curved down and attaches to the lower end of the drive link. The forward upside down drive link is attached to a fitting on the backside of the wing rear spar and has the rotary actuator built into its hub. The side-by-side support beams that provide the aft pivot point at their aft end are attached to the lower surface of the wing box. They are connected to each other with tie plates wherever possible for side stability. The lateral stack up of parts is about equivalent to 3.5 structural members. The side load reaction is preferably through the track into the pivot and the end of the side by using side support beams. The drive link can be designed with a joint to avoid side load reaction and to simplify the drive train. The fairings consist of a fixed forward fairing attached to the wing box

lower surface and a movable aft fairing. In figure 12 the fairing is shown as being attached directly to the flap because it is not too long, but it could also be hinged and slave linked down (heavier).

Streamwise and conical deployment with this mechanism is easy to accomplish for swept outboard flaps. The inboard track is arranged streamwise and is designed to take the flap side loads. The outboard track only has to be skewed outboard a little and not be designed for side load reaction.

Figure 13 shows an alternate design concept for the Boeing link/track mechanism with flap end supports. This approach looks very attractive since the size of the support fairings can be greatly reduced. The flap motion of the end supported version is almost identical to the conservative approach with supports underneath.

For the end supported version, the track is moved up as far as possible to hide the track inside the flap airfoil contours. The flap end rib and the flap fitting are combined into one structural element, and tracks are attached to the outside of these end rib/flap fittings. The depth of the track is increased, and there is only one roller riding in it. This single roller could be replaced by a roller carriage or a smaller sized slide block for better wear characteristics and a reduced size track. The roller or slide block is mounted to the end of a support beam that is attached to the back side of the rear spar. This support beam is built like a rib and with an "I" beam cross section (at the Yehudi break) and is shaped such that the flap ends are nested inside the upper and lower chords. This permits the gap between inboard and outboard flaps to be minimized. Side load reaction again is preferably through the tracks. The forward drive link geometry is similar to the conservative approach shown on figure 12. Streamwise and conical deployment with this mechanism can be accomplished in a way similar to the conservative version.

Since the outboard flap has too large a span for end supports only, a third forward drive link is shown in the middle of the outboard flap. It is assumed that the inboard flap is stiff enough to get by with only two end supports, so there are three support fairings per wing. The middle one, which only houses the drive link, is very short and narrow (equivalent of 1.5 side-by-side structural members). The outboard support of the outboard flap is the next larger in size. It houses a track support beam, a track and a forward drive link (2 structural members). The joint support for the inboard and outboard flaps at the Yehudi break is the widest fairing and contains a dual support beam, two tracks

(riding inside support beam), and two forward drive links. This is about equivalent to 4 structural members. The inboard support of the inboard flap is assumed to be buried in the side of body. All three fairings consist of two parts. The forward fairing is attached to the wing box, and the aft fairing is attached to the flap and rides with it. The sealing between the inboard and outboard flaps is fairly easy since the gap between the flaps is very small. The aft fairing could be used as a seal on the lower flap surface and the small slot on the upper surface is unsealed. In order to keep the fairing from becoming a structural member that ties the two flaps together, the aft fairing could be split along the line of the Yehudi break with a seal along the split line.

A different arrangement of the supports is possible, where the end tracks and drive links are no longer co-located (see wing planform of fig. 15).

### 3.9 Boeing 767 Type Hinged Beam Four Bar Linkage (Layout LO-PKCR-97-15), Figure 14

At the beginning of this study, there were no plans to investigate the Boeing 767 "Hinged Beam Four Bar Linkage" because it was considered too complex. The expectations were that it would never be used again. The Boeing 777 program was planning to use the simple "Upside Down/Upright Four Bar Linkage" on the outboard and inboard flaps, but the deep fairing of this simple mechanism caused an interference drag problem between the engine strut and the outboard support of the inboard flap. The cure for this problem was to use the Boeing 767 complex four bar linkage on the inboard flaps. This linkage has a very shallow but wide fairing which is small enough to not cause a drag problem. The fact that this concept has been re-used on a second Boeing airplane brought about a change in mind. So, the Boeing 767 complex four bar linkage was added to the mechanisms studied under this design effort.

The upside down/upright four bar linkage used on the Boeing 777 outboard flap has been studied many times in the past. It provides modest Fowler motion at typical takeoff flap angles. But its major drawback is that the aft link is quite long and requires a deep flap support fairing. The 767 flap mechanism designers overcame this problem by making the pivot for the aft link move down and up during flap deployment. This not only reduced the support and fairing depth, but it also considerably increased the Fowler motion for typical takeoff flap settings. The best quick description for the Boeing 767 flap mechanism is "Hinged Beam, Upside Down/Upright Four Bar Linkage."

Figure 14 shows an adaptation of the 767 mechanism to the study airfoil. The forward upside down drive link has its hinge point in the common location used for this study. The rotary actuator is integrated into the drive link, and the lower end of this drive link is connected to the forward lower end of the flap fitting to which the flap is mounted. The drive link and the forward end of the flap fitting at the inboard support location are reacting the flap side loads. The hinged beam is pivotally mounted on its forward end to a fitting on the lower surface of the wing box. The hinged beam is wide and forked at its forward end to let the drive link pass through, and both drive link and hinged beam are symmetrical relative to the axial centerline of the support. The two beam slave links attach to the outside of the drive link and the hinged beam. The very aft end of the hinged beam narrows and provides the lower pivot for the upright aft link which attaches to the aft end of the flap fitting with its upper end. To further clarify the stacking of the links, the wide and forked hinged beam straddles the forward drive link which is in the symmetry plane, and the two hinged beam slave links straddle the hub of the forward drive link and the hinged beam. The aft link is single and in the symmetry plane. The side-by-side stack up of parts is equivalent to six structural parts in the forward 75% of the support mechanism. Therefore a very wide fairing is needed. But the mechanism is shallow, so the fairing is not very deep, and it is quite short. The fairing is shown with a stationary front part that is attached to the wing box, and a moving aft part that is attached to the flap.

The flap motion is quite sophisticated. As the drive link starts to move the forward end of the flap down and aft, the hinged beam is rotating down, lowering the pivot point for the aft link. At the same time the upright aft link, which leans forward in the stowed position, starts to rotate up and aft. This starts a counter clockwise rotation of the flap which produces a lot of Fowler motion before the flap even starts to deflect down. The dropping of the pivot for the aft link negates the upward motion from the initial aft link rotation and prevents the flap from hitting the trailing edge of the spoilers.

The slot development looks good. A nice convergent slot already exists at the flap 0° position, and the slot opens to around 3% for flap angles between 15° and 27.5°. Then the slot closes down to 1.3% very quickly as the flap approaches 35° deflection. The flap gaps may be a little on the large side for typical takeoff flap settings, but this can be corrected with minor changes to the mechanism geometry. Because of the large number of variables in this complex mechanism, this fine tuning should best be done in a computer aided design iteration and not manually.

The wing planform scheme shows two supports for the outboard flap at about 25% from the flap ends. The inboard flap has an inboard support inside the fuselage and the outboard support is shown as an extension of the engine mount strut which is right at the centerline of the engine. In order to avoid jet impingement on the aft flap fairing, the fairing behind the engine should not be attached to the flap (as shown in fig. 14), but should rather be hinged and rotate down. The contractor was not able to find a slave link mechanism for the aft fairing rotation. The problem is that the flap moves down very quickly during initial deployment and requires an equally quick movement of the aft fairing. A solution to this problem can probably be found through more extensive design iterations.

Streamwise and conical deployment with this mechanism is difficult to achieve for swept outboard flaps. If the inboard forward link is taking flap side loads, some adjustment in motion is required on the outboard support (outboard skew of the outboard mechanism or a forward link with hinge).

#### **4.0 Growth from Single Slotted to Vane/Main Double Slotted Flap**

Most of today's commercial airplanes in service are built as airplane families. One growth pattern is to build a medium size airplane first, followed by an increased gross weight version for improved range, followed by an even higher gross weight version with stretched fuselage and eventually a shortened fuselage version (A319 <---A320-100---> A320-200---> A321). Another growth pattern can be observed on the next generation Boeing 737 models where there is, by edict, a common high lift system on all models. However, for every one of these models there is a different optimum high lift system.

A new methodology for the optimization and design of high lift systems should address airplane growth and the options to adapt the high lift system to the respective gross weight and fuselage length of each model. A particular airplane program may elect to produce only one high lift configuration in order to simplify the logistics of the side-by-side production of the different models. But nevertheless the methodology should attempt to find and research good ways to grow the high lift system with airplane growth. This will help to determine what the trades are between performance, weight and cost.

The reference 1 contractor report identified the change from a single slotted to a fixed vane/main double slotted flap, while using the same mechanism and actuation, as the simplest and cheapest growth step. Growth may also

include a slight increase in wing and flap chord. When designing a vane/main double slotted flap, the most important requirement for the mechanism is that it provides several single slotted flap positions at flap angles between 5° and 20° for good takeoff lift to drag ratios. A second slot would produce too much drag. Therefore, the mechanism has to be tailored such that the upper surface of the vane slides along the lower surface of the spoilers for the prescribed range of takeoff flap angles.

Only those mechanisms developed for the single slotted flap that show a gradual increase in slot size can possibly meet this requirement. Of the 7 mechanism types studied only the simple hinge (the conservative version of the Boeing 777 upside down/upright four bar linkage) and the Boeing link/track mechanism come close to meeting this criterion. The Airbus A330/340 link/track mechanism in the reference 3 patent shows a mechanism capable of producing single slotted takeoff flap positions. But, there is little chance that an identical mechanism can be used to mechanize the single and vane/main double slotted flaps.

Three mechanisms were considered as candidates for growth—the simple hinge, the upside down/upright four bar linkage, and the Boeing link/track mechanism. The simple hinge needs all new hinge and support structure when going from a single slotted flap with 35° deflection to a vane/main flap with 45° deflection and was rejected. The upside down/upright four bar linkage is probably not one of the favored mechanisms, as will be discussed later, so no attempt was made to try it for this growth step. The Boeing link/track mechanism was investigated for this growth capability in earlier design efforts by the contractor and was found to be compatible with the requirements for the vane/main flap. This mechanism is considered a leading growth candidate, and it is evaluated in the following sub-section.

#### **4.1 Boeing Link/Track Mechanism with End Supports for Single and Vane/Main Double Slotted Flaps (Layout LO-PKCR-97-16), Figure 15**

The flap mechanism chosen for the design of a common mechanism in figure 15 is the Boeing link/track mechanism with end supports. This exercise could have also used the conservative approach with the supports underneath the flaps. This layout is a very first attempt to prove the feasibility of this growth concept for the given airfoil, flap shape and Fowler motion. To arrive at a more optimum configuration for both types of flaps, more design iterations will be required. The flap and wing

chord for the vane/main flap is shown to be 5% longer than the single slotted flap. This is the second part of the proposed growth steps, but it is not necessary for this concept to work. The layout was done assuming a predetermined optimum vane/main configuration and position for full deployment. The assumed values are 45° maximum flap angle, 0.75% first gap with 0.4% overlap, and 0.8% second gap with 1.4% overlap. The maximum flap angle for the single slotted flap is 35°. Overlap and gap for the single slotted flap are a fall out. The slot at 35° flaps is 0.75% and the overlap 1.8%. These values are probably not optimum, but certainly not too far out of line.

Since the detailed description for figure 13 is applicable to the layout in figure 15, only a brief description detailing the differences follows. The straight tracks are the only support at the ends of the flaps. The support at the Yehudi break houses only the aft pivot support for the outboard end of the inboard flap and the inboard end of the outboard flap. Single track supports are at the outboard end of the outboard flap and the inboard end of the inboard flap. The two forward link supports for the outboard flap are located at 25% from the flap ends. The two forward link supports for the inboard flap are behind the engine strut and inside the fuselage. The member riding inside the track is shown as a single roller, but could also be a slide block. The pivot point for the rollers or slide blocks are on a support beam or rib that is at its forward end and attached to the backside of the rear spar. This rib is essentially inside the aft airfoil and only a small aft portion protrudes down and requires a small fairing. The inboard and outboard flaps at the Yehudi break are separated by the web of the rib, and seals on the flap ends can close this small gap when the flaps are deployed. The tracks, which are mounted to a flap end rib, locally block the vane/main slot and protrude forward from the vane. This is something that could probably be improved upon through a design iteration. It is assumed that the respective inboard tracks are used to react flap side loads. Therefore, narrow drive links with a hinge can be built. This makes the drive link fairings slim, and the drive train for the actuators can be in line. If the drive link fairing behind the engine strut is counted as half a fairing, this configuration has 4.5 small fairings per wing.

In order to give the vane a better shape, the thickness of the spoiler was reduced a little on its forward end. The vane/main flap is shown in solid lines and the single slotted flap in dashed lines in their respective stowed positions. Only two intermediate flap positions are shown for the two flap concepts, flaps 5° and 20°, and the final position is at 45° for the vane/main flap and 35° for

the single slotted flap. The trailing edge of the vane is sealed against the trailing edge of the spoiler at flaps 5°, and the vane upper surface slides along the spoiler trailing edge until about the 25° position. This makes the vane/main flap single slotted for all possible takeoff positions. The favorable pressure gradient created by the suction from the second slot should help keep the flow attached on the vane curved upper surface. This flow is in the presence of the fairly thick boundary layer from the main wing. The gap for the single slotted flap only reaches 0.5% at flap angle 30°. This may have to be corrected through a design iteration.

Figure 16 shows the Fowler motion progression for this common mechanism for single slotted and vane/main flaps and compares it to the progression of the uncompromised single slotted flap of figure 13. The linkage compromised for the vane/main double slotted flap has significantly lower Fowler motion for typical takeoff flap angles—about 4% less at flaps 5°, 3.5% less at flaps 10°, and 3% less at flaps 20°. The Fowler motion at maximum flap angle for the single slotted flap is 1.8% lower. Some of this deficiency can probably be reduced through a more refined mechanism design. However, the possibility of retaining just a common drive link and the basic support structure for the aft pivot but changing the location of the aft pivot should be considered. This would result in more optimized flap positions for both flaps.

In summary, this layout shows that the Boeing link/track mechanism is suited for a high lift system growth from single to vane/main double slotted flaps while using the same mechanism, drive train and flap fairings. The only major changes are new flap panels with or without chord increase, a new lower cove panel and a beef-up of the structure if this has not been done originally. Based on past experience with this mechanism, it can be said that the Boeing link/track mechanism with two conventional supports is best qualified for the growth step to a vane/main flap using a common mechanism.

## 5.0 Preliminary Comparative Evaluation of Mechanism Concepts

### 5.1 Fowler Motion and Gap Development

The CFD analysis of the flap position matrix is not complete at the time of this writing, but some tendencies are evident. The two dimensional analysis results suggest that high Fowler motion at typical takeoff flap angles not only increases lift, but also improves lift to drag ratio. This will give mechanisms with high initial Fowler motion good marks. The picture for optimum gap sizes is not clear yet. However, it does appear that

gap size is fairly important at the high flap angle settings, in particular at maximum deflection where the optimum gap may be as low as 0.75%. Flap gap becomes a lesser factor at lower flap angles and tends to optimize closer to 2%. This is all based on analysis at an angle of attack, alpha, of 8°. The picture may change when maximum lift coefficient is evaluated, but this analysis has yet to be done. With the limited analysis on hand, the following assessment on flap position can be made (see figs. 17 & 18 for Fowler motion, and fig. 19 for gap development).

The simple hinged flap has by far the poorest Fowler motion progression which is essentially linear with flap deflection angle. At a high gross weight takeoff flap angle of 5°, it has only about 2.5% Fowler motion, whereas the best mechanism produces almost 12%. Even at a 20° flap setting for low gross weight and short takeoff, it still is 6 to 6.5% below the best mechanism. The gap development is not good either. The gap reaches 0.25% at a flap angle of 12.5°, but then closes down and starts to rise again at 30° flap angle.

The conservative 777 upside down/upright four bar linkage about doubles the Fowler motion of the simple hinge at 5° flap setting and adds 3% at flaps 20°. The gap develops quite nicely and reaches 1% at a flap angle of 13°.

The more aggressive Boeing 777 upside down/upright four bar linkage adds another 2.5% of Fowler motion at a flap angle of 5° but only 1% at flaps 20°. The gap development for this mechanism is changed drastically over the conservative approach. The gap opens up much faster and reaches 2.6% at a flap angle of about 24° and then drops steeply to the prescribed 1.3% at full flap deflection.

The YC15 upside down four bar linkage is only 1% better in motion progression than the simple hinge at a flap angle of 5° and about 3% better at a flap angle of 20°. The flap gap develops quite erratically, reaching almost 1.8% at flaps 13° and dipping to a little less than 0.5% at flaps 26°.

The Short Brothers upside/down four bar linkage has a Fowler motion progression similar to the 777 conservative outboard four bar linkage with only a 0.5% advantage at flaps 20°. The gap opens up very quickly and reaches 1.9% at a flap angle of 5°. However, the reversal on the S-curve dips down to a low of about 0.8% at flaps 26°.

The Boeing 747 SP upside down four bar linkage Fowler motion starts out on a steep linear curve. It is only 6.5% at 5° flap, but starting at about 11° flap angle it exceeds all other flap mechanisms in Fowler motion. This suggests that this mechanism may have some favorable applications on short to medium range airplanes where the critical takeoff case is at low gross weight from a short field with higher flap settings. The gap development for this mechanism is pretty wild, reaching more than 3.7% gap at about 5° flaps and then dropping to the nominal gap of 1.3% for landing flaps.

The Airbus A330/340 link/track mechanism has a little more Fowler motion at flaps 5° than the simple hinge at 20°. This makes it a very good choice for high gross weight takeoff long range airplanes. Fowler motion at 20° flaps is not bad at 14.25%. The flap gap develops fairly quickly and reaches a high of less than 2% at flaps 10°. The drop to the nominal 1.3% at 35° flaps is gradual.

The Fowler motion progression for both of the conservative and the end supported Airbus A320 link/track mechanism is very similar and shows close to 10% Fowler motion at flaps 5° and 15+% at flaps 20°. This puts the A320 mechanism in league with the Boeing 767, Boeing link/track and Boeing 747 SP mechanisms. The gap development is fairly rapid initially, peaks at a little over 2.5% and then drops gradually to the nominal gap of 1.3% at landing flaps 35°.

Both Boeing link/track mechanisms, conventional and end supported, have similar characteristics in Fowler motion progression and gap development. They reach the highest Fowler motion of any mechanism at 5° flap setting at between 11 and 12% and are second only to the 747 SP four bar linkage at flaps 20°. The gap development is slow and makes this mechanism a candidate for easy adaptation to a vane/main double slotted flap for growth.

The Boeing 767 hinged beam four bar linkage is just a little below the Boeing link/track mechanism in Fowler motion progression, so it is very competitive from this aspect. The gap development is a little wild, reaching 1.75% at flaps 5° and 3.2% at flaps 27° before dropping steeply to the nominal 1.3% at flaps 35°. It may be possible to improve on the gap development by sequencing the hinged beam motion differently.

## 5.2 Flap Spanwise Continuity

The flap spanwise continuity between inboard and outboard flaps and the slot blockage by the flap supports and fairings also impacts high lift performance. Since all flap mechanisms considered were exercised to allow streamwise conical motion of the outboard flaps, there are no large gaps between inboard and outboard flaps on any of the concepts. Even the simple hinged flap has this special attachment scheme that allows streamwise motion. But there are three flap mechanisms with end supports in this study. The end supports at the junction of inboard and outboard flaps (Yehudi break) occupy a finite lateral space between the adjacent flaps with support structure, tracks and/or links.

The 747 SP upside down four bar linkage is one of the three. The solution suggested to minimize the lift discontinuity problem is a fixed fence that houses the support structure and a fairing on the flap lower surface that houses the aft link. The A320 end supported link/track mechanism has a similar problem. The fixed fence could be used here, but the solution shown is a fairing on the lower surface that provides a seal between inboard and outboard flaps. The end supported Boeing link/track mechanism has the problem to a lesser degree because the flaps are only separated by the thickness of the support beam web. On the two end supported link/track mechanisms, one always has the option to go back to the conventional support with very little change in motion. But the smaller fairing sizes associated with the end supports are tempting. The 747 SP four bar linkage has no fall back position without end support. These considerations do not rule out any one of these three mechanisms, but before committing to one of them one would have to do a lot of additional work to understand the possible penalties.

## 5.3 Fairing Size and Number of Fairings

Fairing size and number of fairings have a significant impact on high lift systems performance, weight and economics. The number of fairings and their width determine how much the fairings will degrade flap performance because flap fairings block the flow into the slot and cause a trapezoidal area of separated flow on the flap upper surface behind each flap fairing. The size of the fairings, width and wetted area, have a direct impact on drag at low and high speeds.

Another factor of fairing size is the impact on weight and cost. It is obvious that fairing weight and cost grow with fairing wetted area, but the relationship is not necessarily linear. Small fairings with double curvature are

inherently stiff. Also, they can generally be attached to the wing box and the flap and gain more stiffness through a direct attachment to these structural members, commonly through skate angles<sup>1</sup>. Therefore, small fairings can quite often be fabricated as simple composite lay-ups. Larger fairing panels that are not directly attached to fixed structure or the flap, such as long aft fairings that are hinged and slave linked, have to be stiffened along their edges. Also, their surfaces will need to be stiffened with the help of doublers, stiffeners or honeycomb which increases unit weight and manufacturing cost. The criterion to determine whether an aft fairing can be attached to the flap or has to be hinged is its length. A very long fairing attached to the flap would protrude down too far and create too much drag. In addition, it may interfere with ground servicing equipment. Short and shallow fairings can be placed behind the engine strut provided the fairing does not protrude below the flap trailing edge at the maximum flap deflection angle. This essentially saves the weight and cost for the fixed forward fairing, the function of which is taken over by the aft end of the engine strut.

There are many trades to be considered when designing the flap mechanisms that affect fairing size. Choosing a larger number of small and especially narrow fairings versus a smaller number of larger and wider fairings may be advantageous. The flow around a larger number of very narrow fairings may not cause any separation on the flap, may have less combined drag, and may result in cheaper and lighter fairings. The size of the outboard support for the inboard flap is an especially sensitive issue on airplanes with underslung wing mounted engines (twin, three and four engine airplanes). This fairing really wants to be behind the engine strut for structural reasons. If it is too deep for this, it generally gets located inboard of the engine strut and as close to it as possible. If this fairing is very deep or very wide or both, it will cause a high speed drag problem (interference drag between the fairing and the engine mount strut).

Figure 20 summarizes the most important flap geometric parameters of the 12 mechanisms investigated. Note that the number of fairings refers to *one wing only*. An aft fairing behind an engine strut is counted as 1/2 fairing. The fairing width is counted as the number of structural members side by side. Note the two rows of data on the bottom of figure 20. If all fairings have the same width, the fairing width is only listed once. However, if the

<sup>1</sup> A skate angle is a small angled piece of sheet metal used for attachment.

fairings widths vary, each width is given starting at the outboard end, for example, the 747 SP has 3 fairings with widths of 2.5, 1.5, and 5 structural members outboard to inboard. The fairing width for the simple hinge is the same for each of its 3 fairings, but it is wider at the top than at the bottom.

At this point of the study it is not possible to make a quantitative statement on the value of the fairing parameters for two reasons: the investigator may have made subjective assumptions that may need to be fine tuned; and, at this time, it is not known how much each parameter contributes to performance, weight and cost. So, at this point in the study, we have to be satisfied with qualitative statements and engineering judgment based on past experience.

The deepest fairing comes with the simple hinge which is 4 structural thicknesses wide at its upper end—two strikes against it. Fairing depth is decreased significantly for the Boeing 777 outboard flap four bar linkage, but it is still critical for interference with the engine strut. The flap mechanisms with the shallowest fairings come with the two end supported link/track mechanisms and the Boeing 767 folding beam four bar linkage. The Boeing 767 linkage and the Short Brothers upside down four bar linkage require the widest fairings with 6 and 5 side-by-side structural members, respectively. The narrowest fairings are those for the front drive links that do not react flap side loads. These fairings have a width equivalent to one-and-one-half structural members, and they can be found on all mid span supports of end supported flaps and all link/track drive link only fairings. The longest fairing is required for the Airbus A330/340 link/track mechanism which has an intermediate fairing depth and a fairly narrow fairing that is equivalent to a width of 3 structural members. The shortest fairings are those for the Boeing end supported link/track mechanism. The lowest number of fairings can be found on the YC15 upside down four bar linkage and the Boeing 767 linkage with 2.5 per wing (outboard support of inboard flap behind engine strut). Most of the mechanisms require three fairings. The mechanisms that may have high speed interference drag problems are in the following order of declining severity: the simple hinge, the Boeing 777 outboard four bar linkage, the Airbus A330/340 link/track mechanism, and the A320 link/track mechanism conventional. All mechanisms with an end support have a problem achieving flap spanwise continuity at the Yehudi break with the Boeing link/track having the least problem.

## 5.4 Complexity

The complexity of the mechanisms can best be expressed in terms of part count for the mechanisms, the actuation and the fairings. This, however, requires a much more detailed design than we have on hand and a lot of time for a careful count. So, we have to use past experience to make an assessment of the complexity.

The simple hinge appears to be the simplest flap mechanism. But it should be noted here that the deep support structure with its huge fairings adds a lot to a real part count. It could very well be that the Boeing 747 SP upside down four bar linkage is simpler, provided the double support at the Yehudi break can be worked out in a simple way. The structural arrangement is so much more efficient than the simple hinge that fewer parts are required. The YC15 upside down four bar linkage may rank in third place for simplicity, followed by the two Boeing 777 outboard flap upside down upright four bar linkages in fourth place. The two end supported link/track mechanisms of the A320 and Boeing are probably close together in fifth place. The main savings in parts count over the conventional A320 and Boeing link/track mechanisms are in simpler tracks and smaller and simpler fairings. The conventional A320 and Boeing link/track mechanisms should be in sixth place. The A330/340 link track mechanism is quite a bit more complex than the A320 and Boeing link track mechanisms because of the extra drive arrangement and the larger fairings, and it should be rated in seventh place. The Short Brothers upside down four bar linkage, as envisioned with all the doubled up links and support beams, will have very high part count and is in eighth place. By far the most complex mechanism considered in this study is the Boeing 767 folding beam four bar linkage in ninth place.

## 5.5 Reliability and Maintainability

Reliability and maintainability probably goes in parallel with the ratings set for complexity, except that there will be more emphasis on the number of moving parts and joints. So, the simple hinge will definitely rate best in these two categories. The only two concepts that really need very close scrutiny in the field of reliability are the two end supported link/track mechanisms which show a single roller operating inside the track. The roller may have to be replaced by a slider to reduce the track loading and achieve good wear characteristics. Other than this there should not be a change in the ratings.



## 5.6 Actuation Loads

The airload, load location and directivity for the various flap positions were not available during the time frame of this study. However, the contractor has analyzed most of the mechanism concepts before and can make some predictions.

First a look at fail-safe or stowing loads. It is generally considered to be desirable to design a flap linkage such that there are only stowing loads, which also means that there is no load reversal during the deploying or stowing motions. But there are other equally important high lift components like slats and Krueger flaps where there is load reversal, and load reversal can not be designed away. So, what is wrong with a trailing edge flap that wants to stay in the fully deployed position? Probably, the key here is that the mechanism should be designed to have a stowing load or moment in the stowed position and for a good portion of the initial deployment. All of the studied mechanisms meet this requirement. Most others also meet the more stringent, but probably unnecessary requirement, for stowing loads throughout the motion. This is certainly true for the simple hinge and all five link/track mechanisms. Of the two 777 outboard four bar linkage configurations, the conservative one probably has a stowing load throughout, but the aggressive one may be close to a load reversal or even into it. The three upside down four bar linkages may also be close to load reversal at the maximum flap deployment. The 767 complex linkage load reversal situation is impossible to second guess and a detailed analysis is required for resolution.

The magnitude of the actuation power requirements will be determined by a load/stroke analysis later in the study based on airload data generated in the CFD analysis. For the purpose of providing a summary for this report, the contractor can make a qualitative input. The lowest actuation loads will be seen on the simple hinge and the two Airbus A320 type link/track mechanisms. This is because the airload resultant force remains close to and aft of the flap hinge axis of the hinged flap. On the A320 mechanism the resultant force is very close to and behind the pivot on the aft roller carriage.

The actuation loads on the three upside down four bar linkages will be quite different. The YC15 linkage reacts the airload in a relatively short moment couple far forward of the airload resultant, so the hinge moment will be quite high. The Boeing 747 SP linkage has the aft link near the airload resultant which keeps the over turning moment on the front link lower. The Short

Brothers four bar linkage has probably the lowest actuation power requirement of the three.

The hinge moments for the Boeing link/track mechanisms peak out at 3 to 4 times the A320 hinge moments, but they are absolutely manageable. The higher hinge moments are caused by the airload moving aft and away from the fixed aft pivot.

The hinge moments for the Boeing 777 four bar linkages are expected to be in the same order of magnitude as those for the Boeing link/track mechanism since the air load resultant again moves aft and away from the aft pivot.

There is no easy guess for the hinge moments of the Boeing 767 hinged beam four bar linkage. The normal operating hinge moments of the rotary actuators used for the Boeing 767 trailing edge flap are 108,000 inch-pounds outboard and 200,000 inch-pounds inboard. This is quite high.

## 5.7 Weight

The weight of the trailing edge flaps includes the weight of the flap panels, the support and linkage, the actuation and controls, and the fairings. On a representative single slotted flap (hooked track) the weight for flap panels is about 30%, for supports and mechanisms about 34%, for actuation about 25%, and for fairings about 11% of the total (ref. 1). In this study we are in the fortunate position of having only one flap geometry and size. So we have several constants which should allow an easier assessment of the remaining variables.

Flap panel weight should not vary much between different mechanization concepts if we account for major flap fittings in supports and mechanisms. Neither should changing from a conventional underneath support to an end supported panel with one or two intermediate supports change flap panel weight much. So, the variable weights in this study are those for supports, mechanisms, actuation and fairings.

Support and mechanism weights are a function of how short and efficient the load path is from the flap airload location to the load reaction into the wing rear spar or box. A mechanism like the simple hinge carries the load all the way down to the pivot and back up to the wing box, and a separate side load reaction is necessary. The simple hinge is probably about as inefficient in its load transmission as the hooked track which has a more direct load path but reacts the bending moment inefficiently in a fairly shallow track. The most efficient load reaction is

probably accomplished by the end supported A320 and Boeing link/track mechanisms, with the A320 mechanism slightly better than the Boeing link/track. The Boeing 747 SP four bar linkage falls into the same category. With the simple hinge and the hooked track mechanisms as a baseline, a savings of up to 50% of support and mechanisms weight may be possible with these two end supported link/track mechanisms. These two mechanisms with conventional supports from below are also more efficient than a hooked track and perhaps could save 25% in weight. The Boeing 777 outboard flap four bar linkage is not much more efficient than the simple hinge structure and should fall into the same class as the simple hinge. The YC15 four bar linkage is bound to be heavy because of the long overhang of the air load resultant. The Short Brothers four bar linkage is heavy because of all the doubling up of links. The heaviest of all mechanisms considered is probably the Boeing 767 hinged beam four bar linkage because of the multitude of side-by-side links and a moment reaction far forward of the air load resultant.

The controls weights for all of the mechanism concepts is probably close to being identical since a centrally located power drive unit (PDU) with an interconnected high speed drive shaft system, brakes and asymmetry sensing devices are envisioned for all mechanisms. The weight of the PDU, shafting and actuators are dependent on the type of actuators used (all but one are rotary actuators) and the maximum normal operating hinge moment. The weight to hinge moment relationship is not linear, but rather it is close to a square root relationship. The in-line drive shaft system of the favored rotary actuators should have a weight advantage over the snorkel drive needed for the screw jack drive. The highest actuation and controls weight variation anticipated is +30% and -20% relative to the baseline screw jack drive of the hooked track mechanism. For controls, the Airbus A320 should be at the lowest end of the weight scale, and the Boeing 767 and the YC15 probably at the upper end.

As was pointed out earlier, the fairing weights are not constant per unit area, but vary with size and concept. The lowest fairing weights can be expected for the end supported link/track mechanisms, followed by the 747 SP four bar linkage and the conventional Boeing link/track mechanism. The highest fairing weights are associated with the long fairings that require a hinged aft fairing, such as the Airbus A330/340 mechanism, the Boeing 777 outboard flap four bar linkage and the Airbus A320 conservative link/track mechanism. The fairings for the simple hinge are also on the heavy side because of their size and flat surfaces.

## 6.0 Preliminary Down Select

To this contractor's knowledge nobody in industry has ever attempted to do as broad a mechanism evaluation as is being attempted in this design study. In industry a mechanism down select between two competing concepts would take several man years of effort by engineers from at least a half dozen different disciplines. The effort put into this study from the design end is somewhere around 200 man-hours, with the inputs in aerodynamics from U.C. Davis. The data that was generated is insufficient to make a real engineering down select that rates every aspect of all the designs and attaching multiplication factors to the various aspects based on their significance. But enough data is now available to make a partial down selection. The technique that is used is one that works on both ends of the spectrum, namely weeding out the concepts that clearly look bad at the bottom end and endorsing the concepts that look like winners. This will leave several concepts in the middle for which neither an endorsement nor a rejection is made.

Starting at the lower end of the spectrum, the simple hinge (fig. 3) is one mechanism that can be clearly rejected as a candidate for this type of single slotted flap. This mechanism has by far the poorest Fowler motion progression and virtually no gap for typical takeoff flap settings, which will give it a low lift coefficient, low lift to drag ratio and premature flap separation. The simple hinge is not so bad for flaps with less Fowler motion or for vane/main double slotted flaps.

The second mechanism that can be eliminated is the YC15 upside down four bar linkage (fig. 6). Its Fowler motion progression is not good, the weight is on the high side, the actuation loads are high and the fairings are quite deep.

The Short Brothers upside down four bar linkage (fig. 7) is the third mechanism that can be rejected. Its Fowler motion at typical takeoff flap angles is mediocre and its structural complexity, and consequently weight, is high. Also, achieving conical streamwise motion is difficult and the fairings are fairly deep and long.

The Boeing 767 hinged beam four bar linkage (fig. 14) is a very smartly conceived mechanism. Its Fowler motion progression at low flap angles is close to the best seen on any mechanism and it has a very shallow fairing. But the mechanism is quite complex, having too many links in series and in parallel. Also, its actuation loads are high, it has a very wide fairing and it has difficulties achieving conical streamwise motion on the swept

outboard wing trailing edge. It is not easy to determine endorsement or rejection.

The Boeing 777 outboard flap upside down /upright four bar linkage (figs. 4 & 5) can neither be rejected nor endorsed easily. Its Fowler motion at typical takeoff flap settings is mediocre, and the complexity at first glance, is not high. But, the size of it makes it complex nonetheless. The depth and width of the fairing around this mechanism made it unacceptable as an outboard support for the inboard flap of the Boeing 777 airplane because it caused interference drag with the engine strut.

The Airbus A330/340 link/track mechanism (fig. 9) is a sound mechanism that provides very high Fowler motion at typical takeoff flap angles and has reasonable actuation loads. It can be endorsed. The fairing is long and fairly deep, so it may cause an interference drag problem with the engine strut at the outboard support location for the inboard flap.

The Airbus A320 link/track mechanism with two conventional supports (fig. 10) is better than the A330/340 link/track mechanism because it is simpler, provides a little more Fowler motion for the higher takeoff flap angles, has lower actuation loads and has a slightly shorter and shallower fairing. It can clearly be endorsed. There seems to be no technical explanation why Airbus went to the A330/340 mechanism after having developed the superior A320 mechanism.

The Boeing link/track mechanism with conventional supports (fig. 12) is a little better than the A320 link/track mechanism with respect to takeoff Fowler motion and fairing length and depth. The actuation loads are significantly higher, but manageable. The Boeing link/track mechanism has the great advantage that the same mechanism can be used to operate a single slotted and vane/main double slotted flap, which is one smart way to provide growth for the high lift system. Even though this mechanism is one of the few that is not in use, it can certainly be endorsed.

The Boeing 747 SP upside down four bar linkage (fig. 8) is a very attractive mechanism. It is very simple, develops very high Fowler motion beyond 10° flap setting, has reasonable actuation loads and has very small fairings. However, the concept is not without some potential major pit falls. The end support may cause a span problem, at least for the outboard flap (see suggested solutions in section 3.5.). The other problem with it is the difficult task of designing the joint support at the Yehudi break such that there is no discontinuity in

the lift distribution (again, solutions are offered in section 3.5.)

The two end supported versions of both the Airbus A320 and the Boeing link/track mechanisms (figs. 11 & 13) are attempts to further reduce flap fairing sizes of their respective conservative configurations without giving up on other good features, such as excellent Fowler motion progression and simplicity. Although listed last, these two concepts are not rated higher than their conventional counterparts. Both of these end supported configurations have the same potential pit falls that were mentioned for the 747 SP four bar linkage with end supports. The spanwise segregation of links and track could help the span problem on the outboard flap. But the joint support at the Yehudi break needs a lot of detail design work before these two end supported concepts can be endorsed without a caution notice. The Boeing link/track support again has a little better Fowler motion than that of the A320.

Since the CFD work for the flaps is not completed, especially the effect of flap gap size on maximum lift coefficient is not yet known, the above selection process may have to be revised later to account for slot size effects.

## 7.0 Conclusions and Recommendations

Seven different flap mechanisms were investigated with a total of twelve different layouts. The down selection made after this investigation is premature since a lot more inputs and investigations are required to make a definite choice. However, the contractor felt that the final report for this 12-month contract needs to transmit all significant results and thoughts developed under the contract to NASA. Because of the preliminary nature of the results the down select distinguishes between outright rejects, uncertain candidates, clear winners and very promising candidates with potential problems.

The outright rejects are:

- Simple Hinge
- Douglas YC15 Upside Down Four Bar Linkage
- Short Brothers Upside Down Four Bar Linkage

The uncertain candidates are:

- Boeing 767 Hinged Beam Four Bar Linkage
- Boeing 777 Upside Down/Upright Four Bar Linkage

The endorsed concepts are:

- Airbus A330/340 Link/Track Mechanism
- Airbus A320 Conventional Link/Track Mechanism
- Boeing Conventional Link/Track Mechanism

The very promising candidates with potential problems are:

- Boeing 747 SP Upside Down Four Bar Linkage
- A320 Link/Track Mechanism with End Supports
- Boeing Link/Track Mechanism with End Supports

The search for mechanisms that allow the growth from single slotted to vane/main double slotted flap has so far only produced one mechanism, the Boeing link/track mechanism, in both the conventional support version (not shown, but done before) and the end supported version.

The U.C. Davis team had selected the simple hinge, the Boeing 777 upside down/upright four bar linkage, and the Airbus A320 link/track mechanism as their candidates for an upcoming effort to develop a computer aided design methodology. The results of this down selection process may have an impact on this choice and may lead to new directions. In particular, since the simple hinge does not produce a viable flap configuration, it should possibly be used only as the zero point for showing the merits of other concepts. However, all analytical and design effort for the simple hinge should be stopped. The Boeing 777 upside down/upright four bar linkage can also be dropped because of its fairly poor ratings. The Airbus A320 link/track mechanism is an excellent mechanism. But it

must be assumed that Airbus has a valid patent, and thus this mechanism concept is not usable without paying royalties. Why should NASA spend any effort and money for the advancement of this concept?

The four lists of mechanisms segregated above must be considered as tentative, and they are subject to change as additional CFD analysis and design work is completed.

## 8.0 Part I References

1. Rudolph, Peter K. C.: "High Lift Systems on Commercial Subsonic Airliners," NASA Contractor Report 4746, September 1996.
2. Mathews, J. R.: "The Aero-Mechanical Design of a Novel Fowler Flap Mechanism." AGARD-CP-515, Sept. 1993.
3. Rudolph, Peter K. C.: "Flap Assembly for Aircraft Wing," U.S. Patent No. 4,381,093 issued April 26, 1983.
4. Rudolph, Peter K. C.: "Airfoil Flap Assembly with Flap Track Member," U.S. Patent No. 4,434,959 issued March 6, 1984.
5. Rudolph, Peter K. C.: "Airfoil Flap Member with Flap Track Member," U.S. Patent No. 4,669,687 issued June 2, 1987.
6. Rudolph, Peter K. C.: "Airfoil Flap Assembly with Flap Track Member," U.S. Patent Re 32,907 issued April 18, 1989.

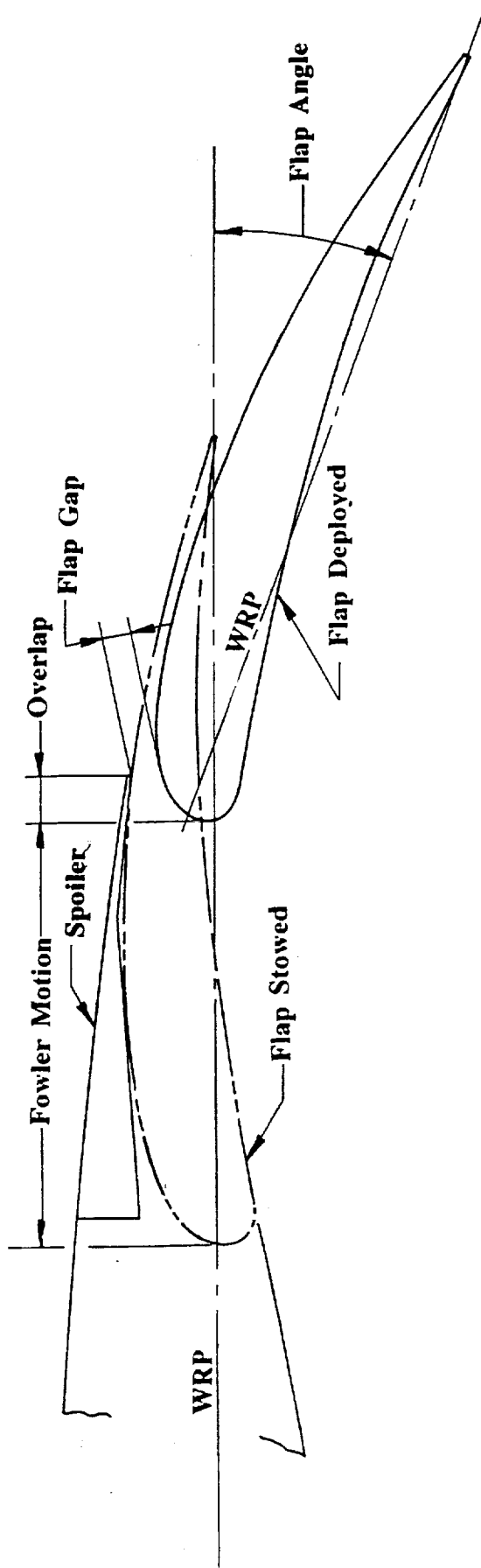

**Figure 1** Trailing Edge Flap Nomenclature

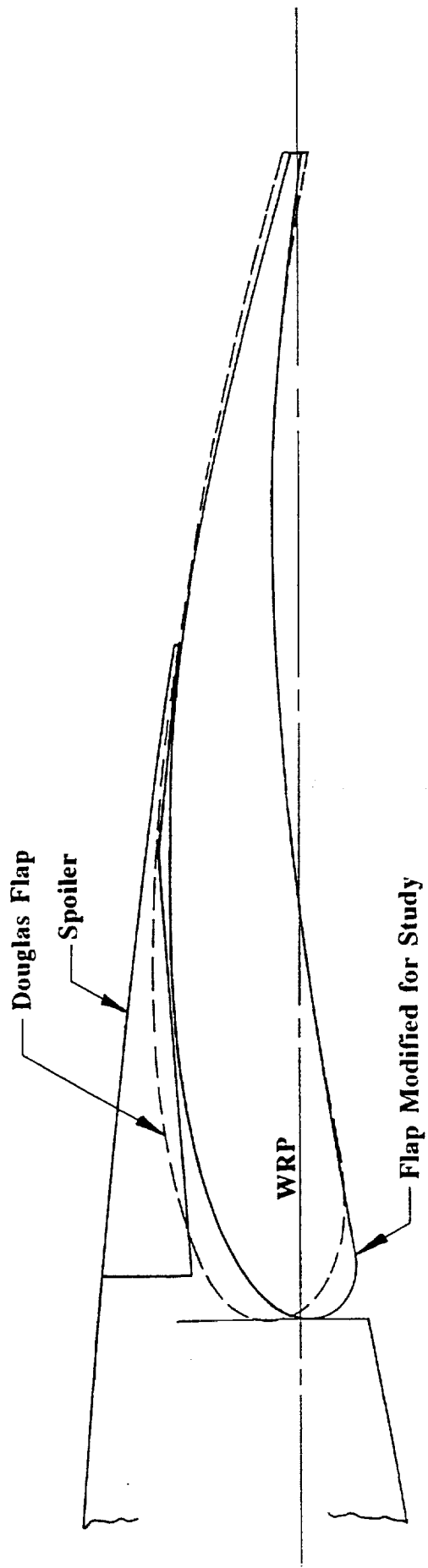

**Figure 2** Definition of the Trailing Edge Flap

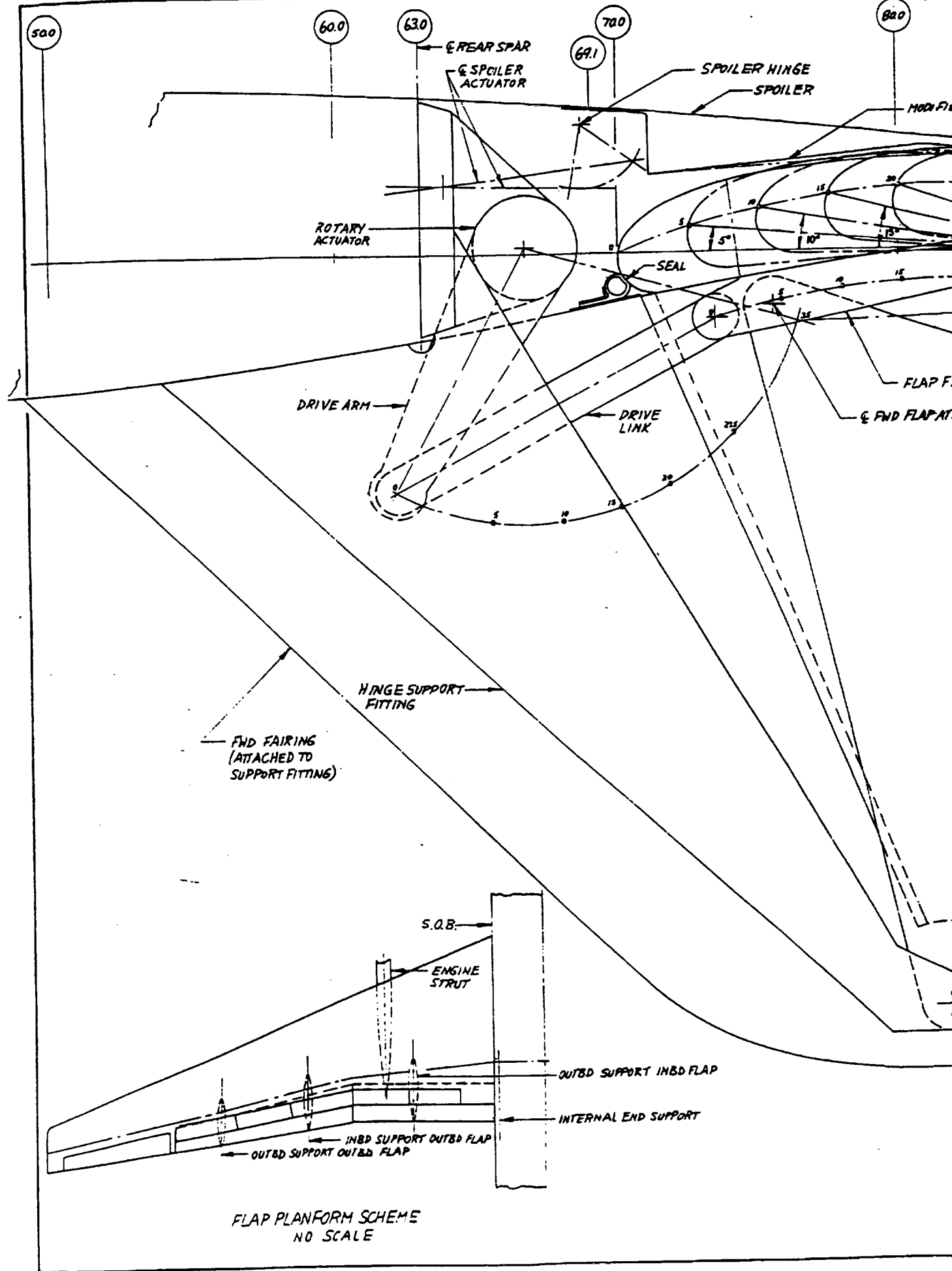
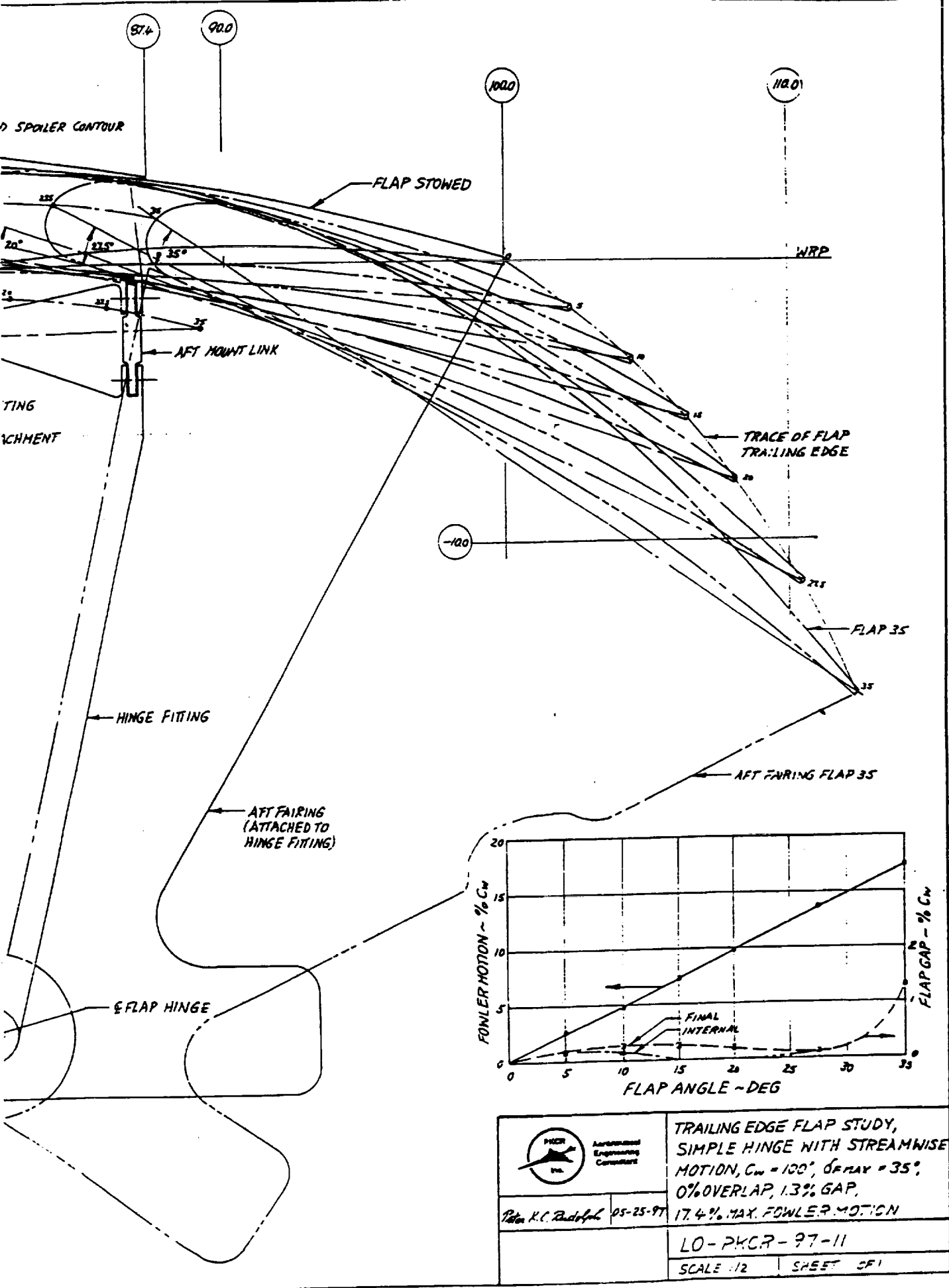



Figure 3

Simple I







 PKCR Aeronautical Engineering Consultants	<b>TRAILING EDGE FLAP STUDY,          SIMPLE HINGE WITH STREAMWISE          MOTION, <math>C_w = 100</math>, <math>\delta_{FLAP} = 35</math>,          0% OVERLAP, 1.3% GAP,          17.4% MAX. FOWLER MOTION</b>	
	By: K.C. Radtke	05-25-97

**This page is intentionally blank.**

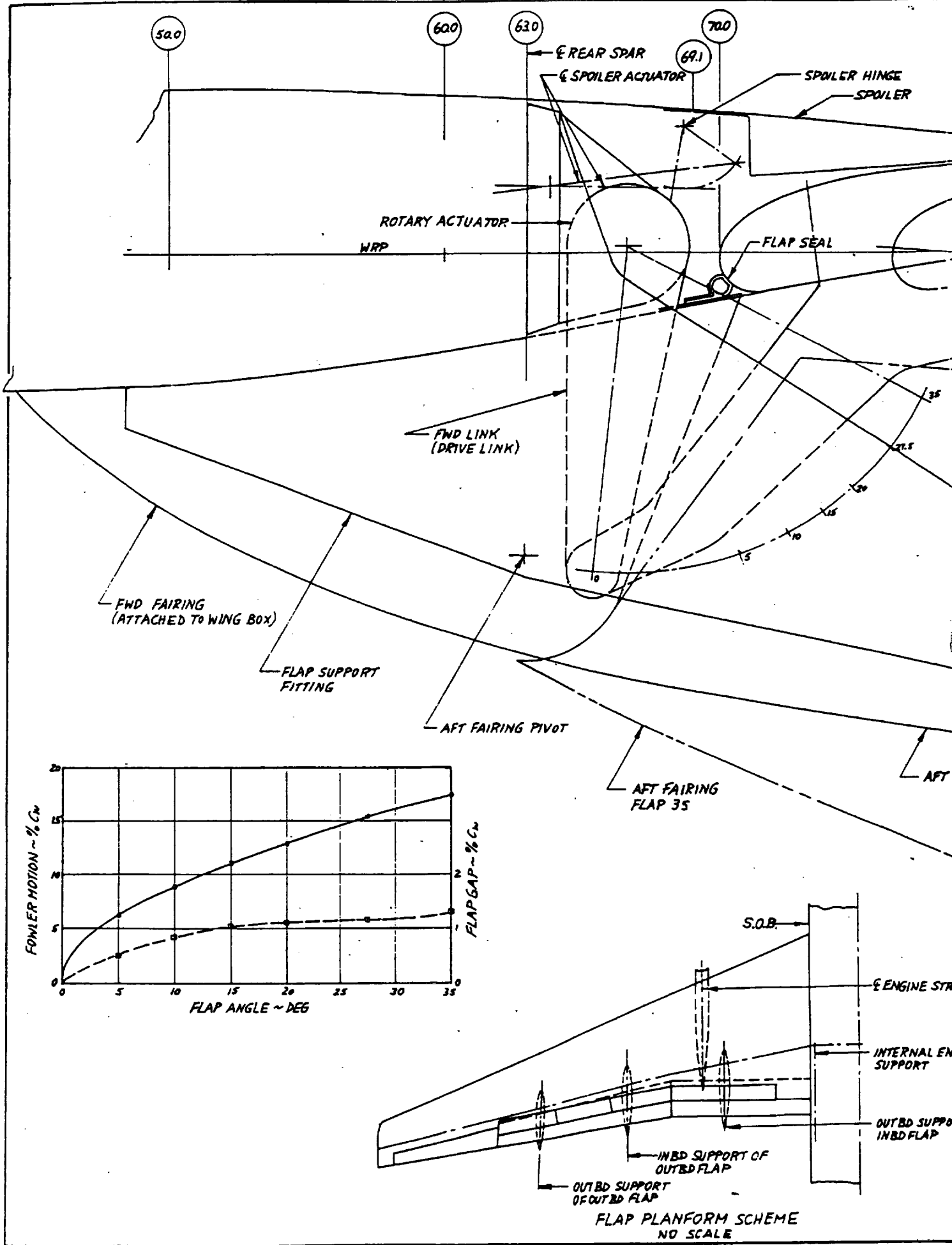
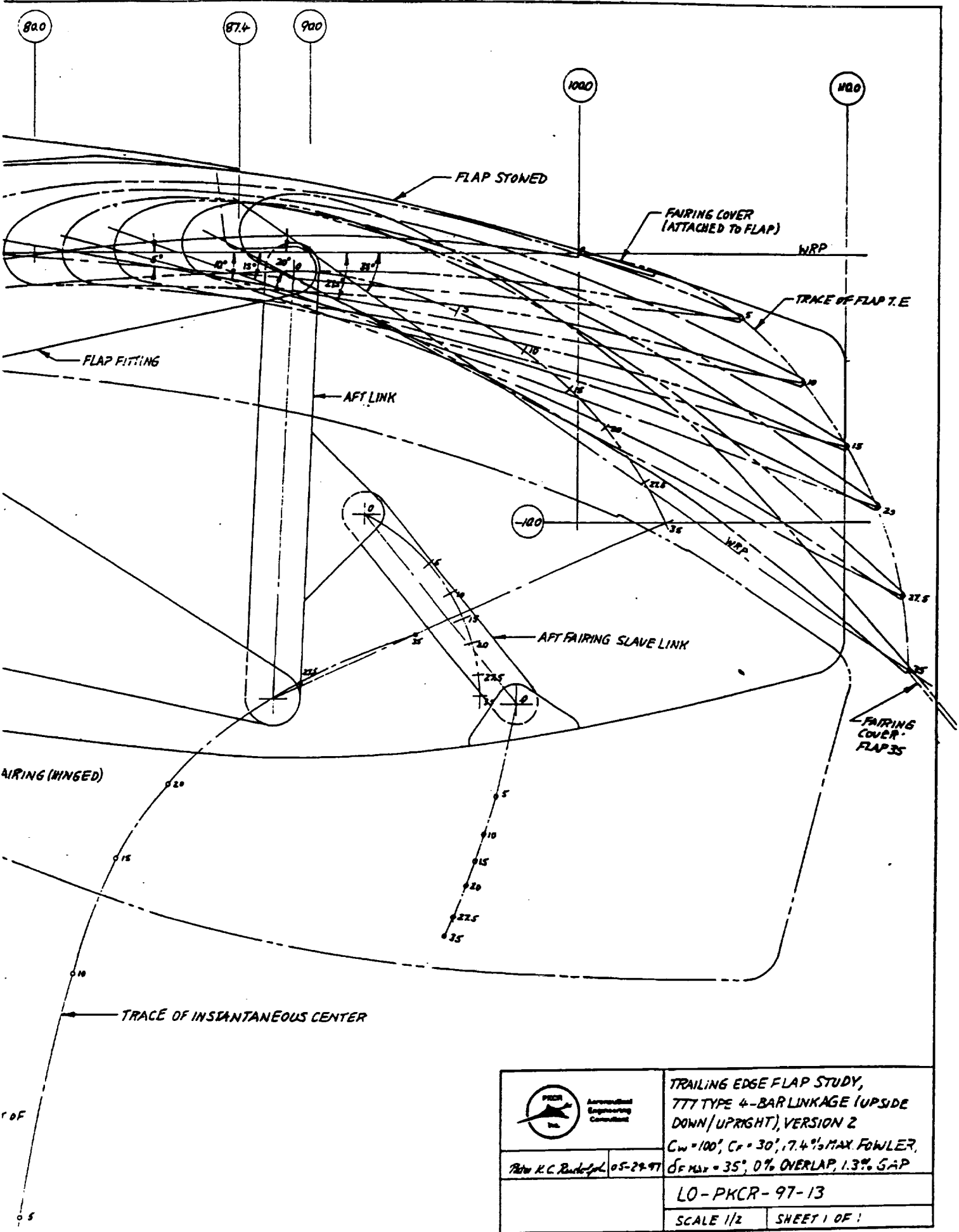



Figure 4 Boeing 777 Type Up (Conservative)





 PKCR Aeronautical Engineering Consultant	TRAILING EDGE FLAP STUDY, TTT TYPE 4-BAR LINKAGE (UPSIDE DOWN/UPRIGHT), VERSION 2	
	$C_w = 100'$ , $C_f = 30'$ , 17.4% MAX. FOWLER, $\delta F_{MAX} = 35'$ , 0% OVERLAP, 1.3% GAP	
Rev K.C. Ruckelshaus 05-29-97	LO-PKCR-97-13	
	SCALE 1/2	SHEET 1 OF 1

side Down/Upright Four Bar Linkage

**This page is intentionally blank.**

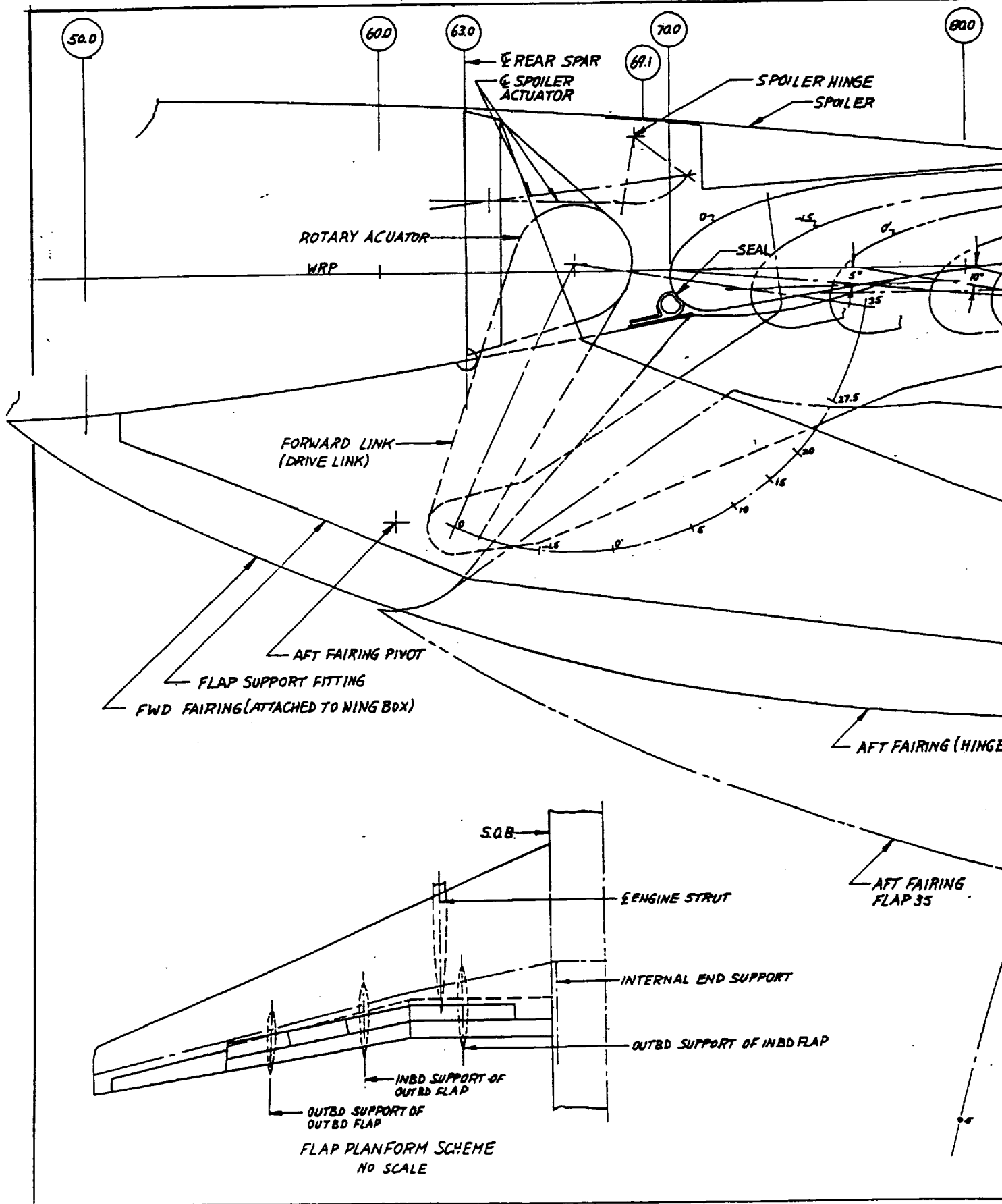
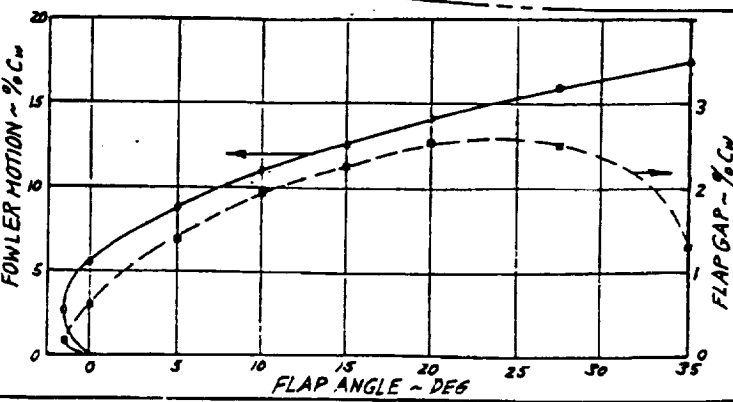
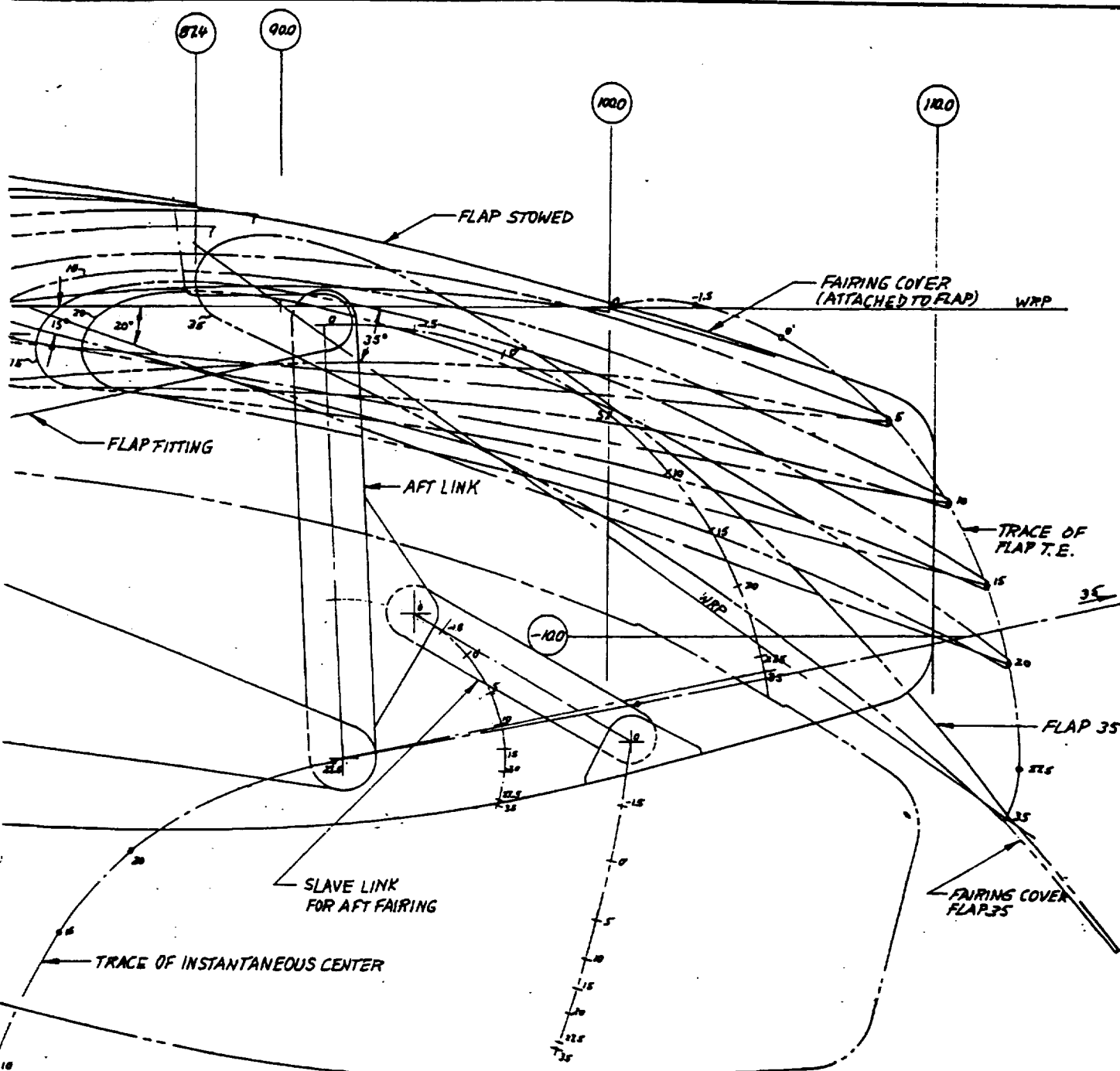



Figure 5

Boeing 777 Ty  
(Aggressive)







 PUGH Aeronautical Engineering Consultant	<b>TRAILING EDGE FLAP STUDY.</b> <b>777 TYPE 4-BAR LINKAGE</b> <b>(UPSIDE DOWN / UPRIGHT), VERSION 1</b> <i>C<sub>w</sub> = 100°, C<sub>p</sub> = 30°, 17.4% FOWLER,</i> <i>35° MAX FLAP, 0% OVERLAP, 1.3% GAP</i>	
	LO-PHCR-??-12	
Scale 1/2		SHEET 1 OF 1

**Upside Down/Upright Four Bar Linkage**

**This page is intentionally blank.**



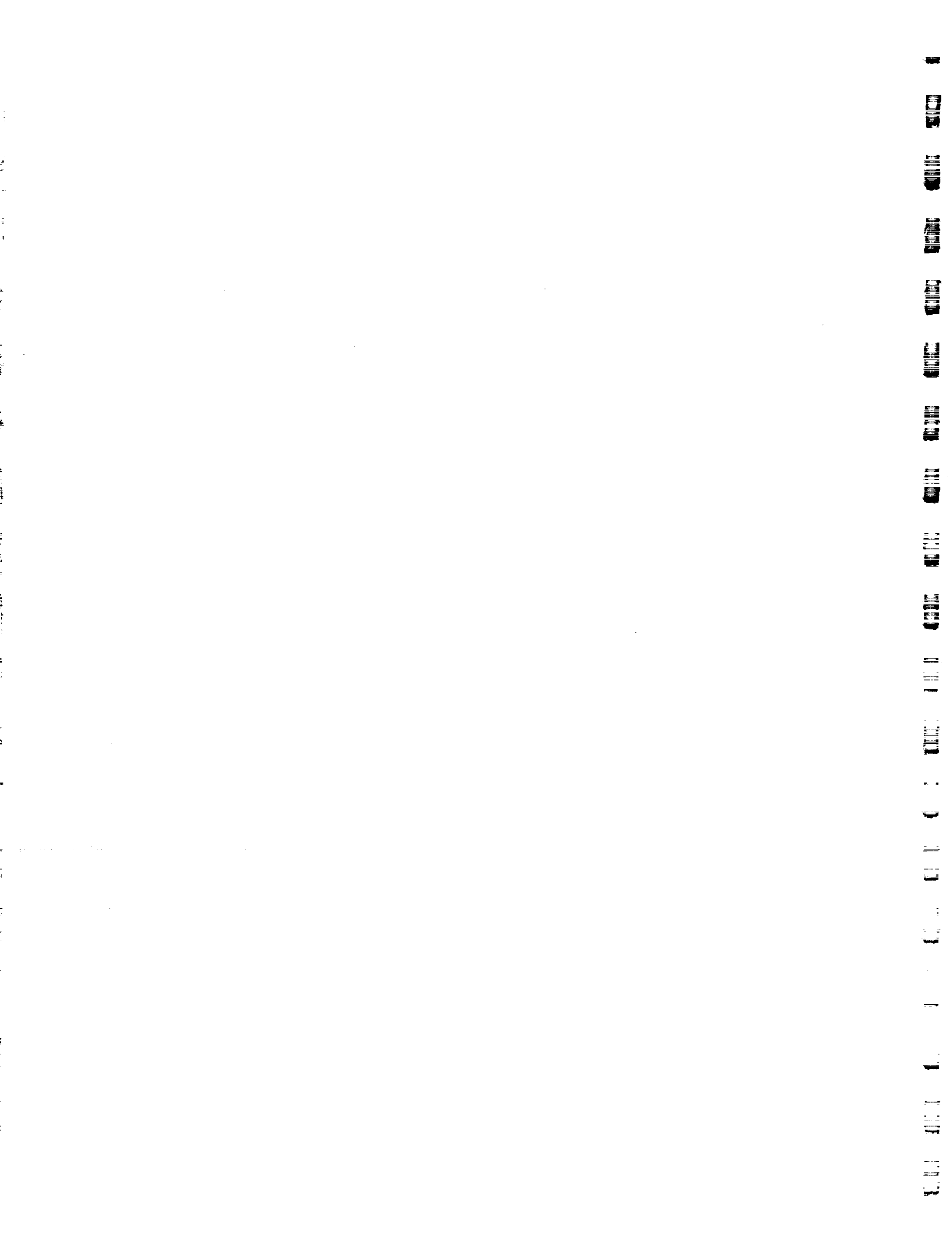

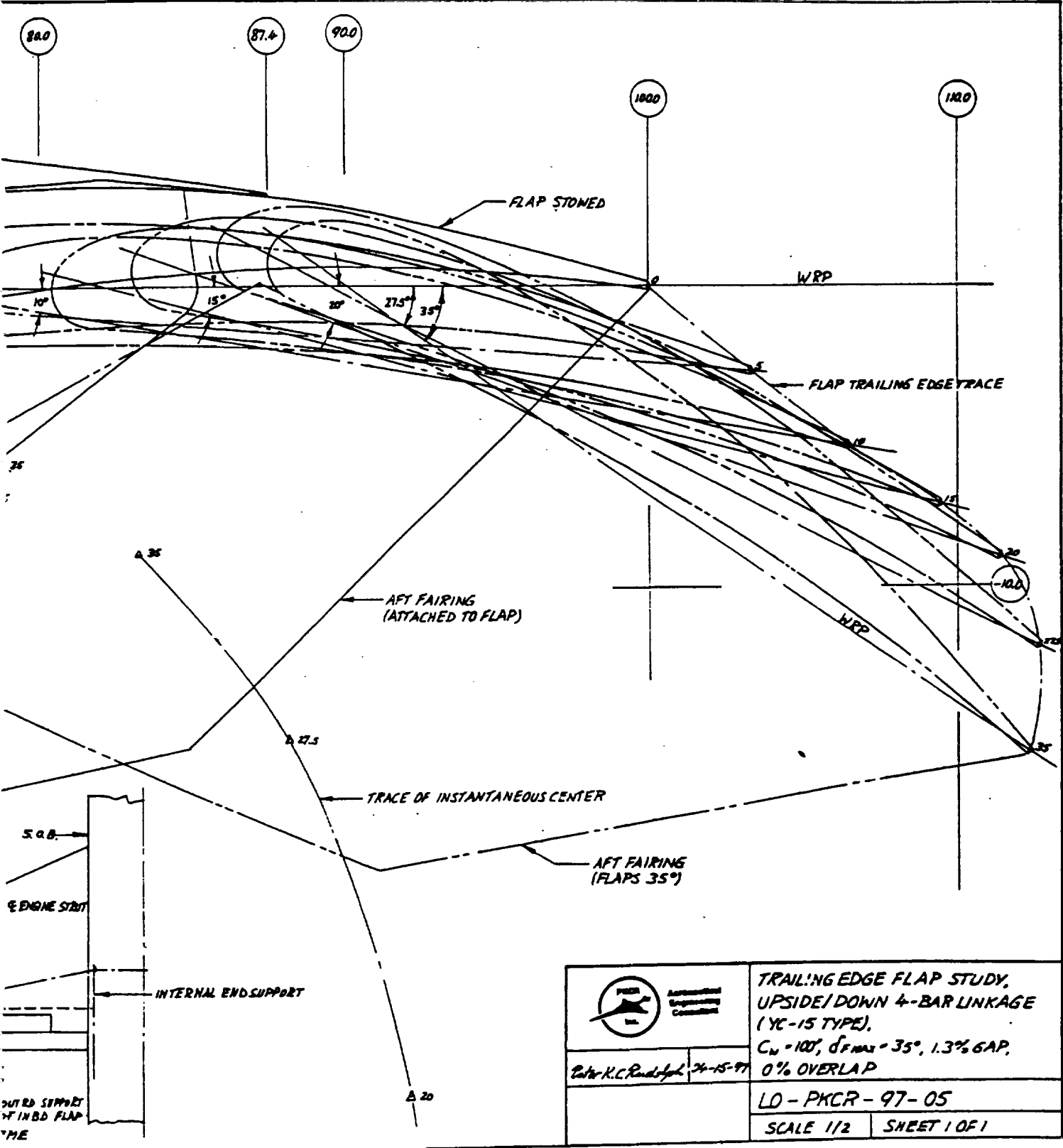

 Associated Engineering Consultant	<b>TRAILING EDGE FLAP STUDY,          UPSIDE/DOWN 4-BAR LINKAGE          (YC-15 TYPE),</b> $C_w = 100, \delta f_{max} = 35^\circ, 1.3\% \text{ GAP},$ <b>0% OVERLAP</b>	
	LD - PKCR - 97 - 05	
Peter K.C. Roodolph 26-15-97		SCALE 1/2 SHEET 1 OF 1

# side Down Four Bar Linkage

**This page is intentionally blank.**

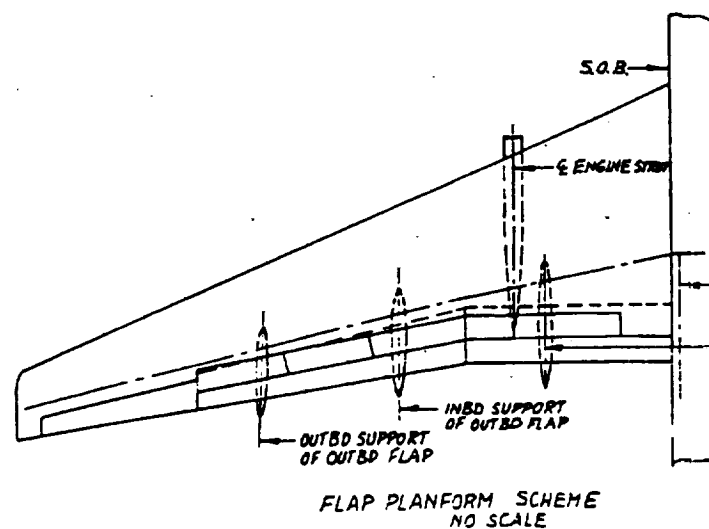
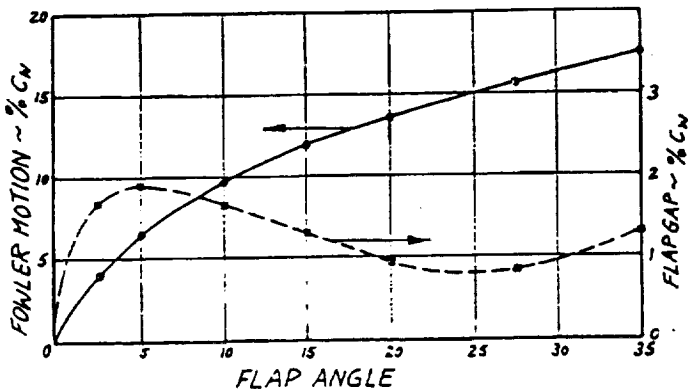
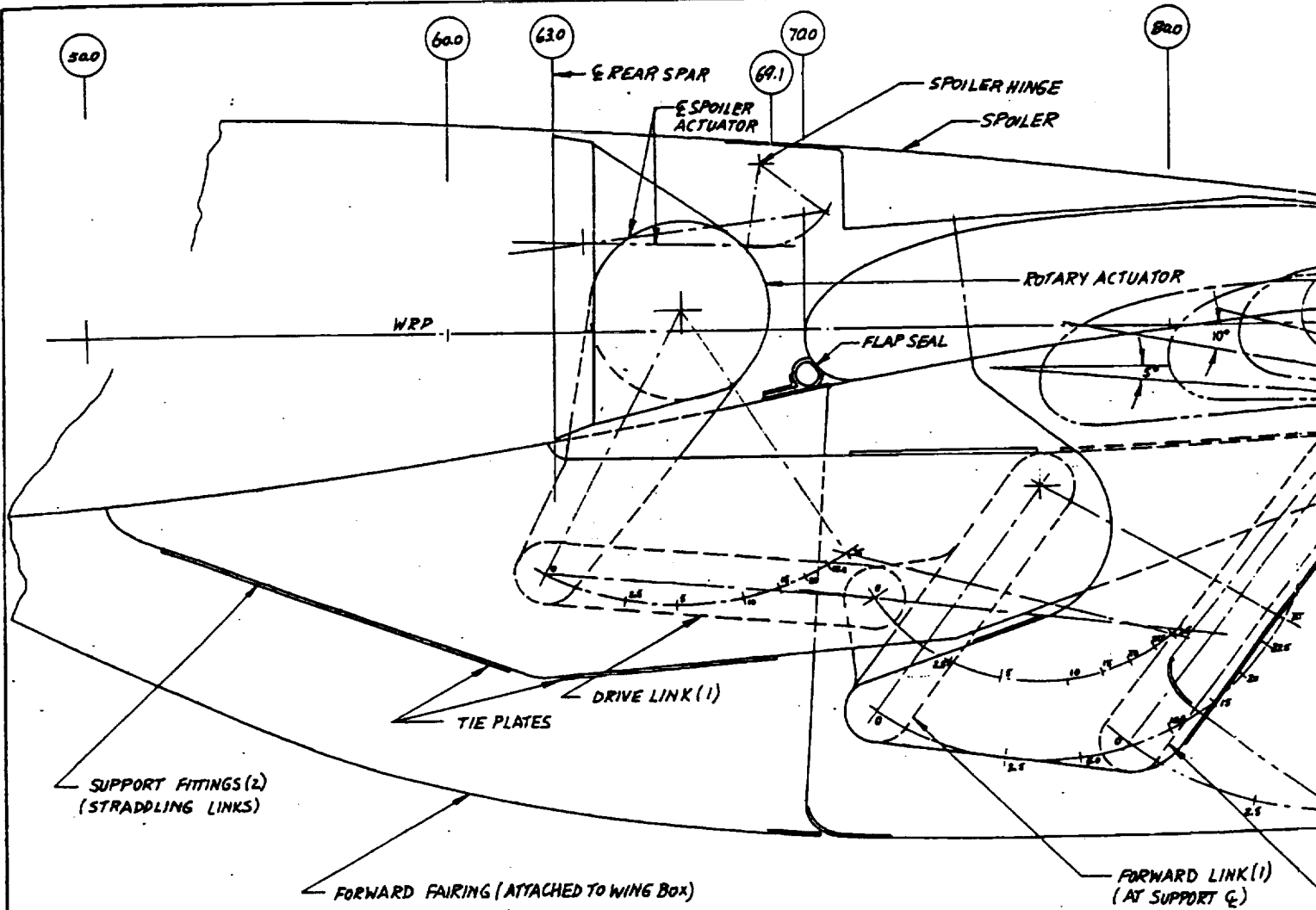
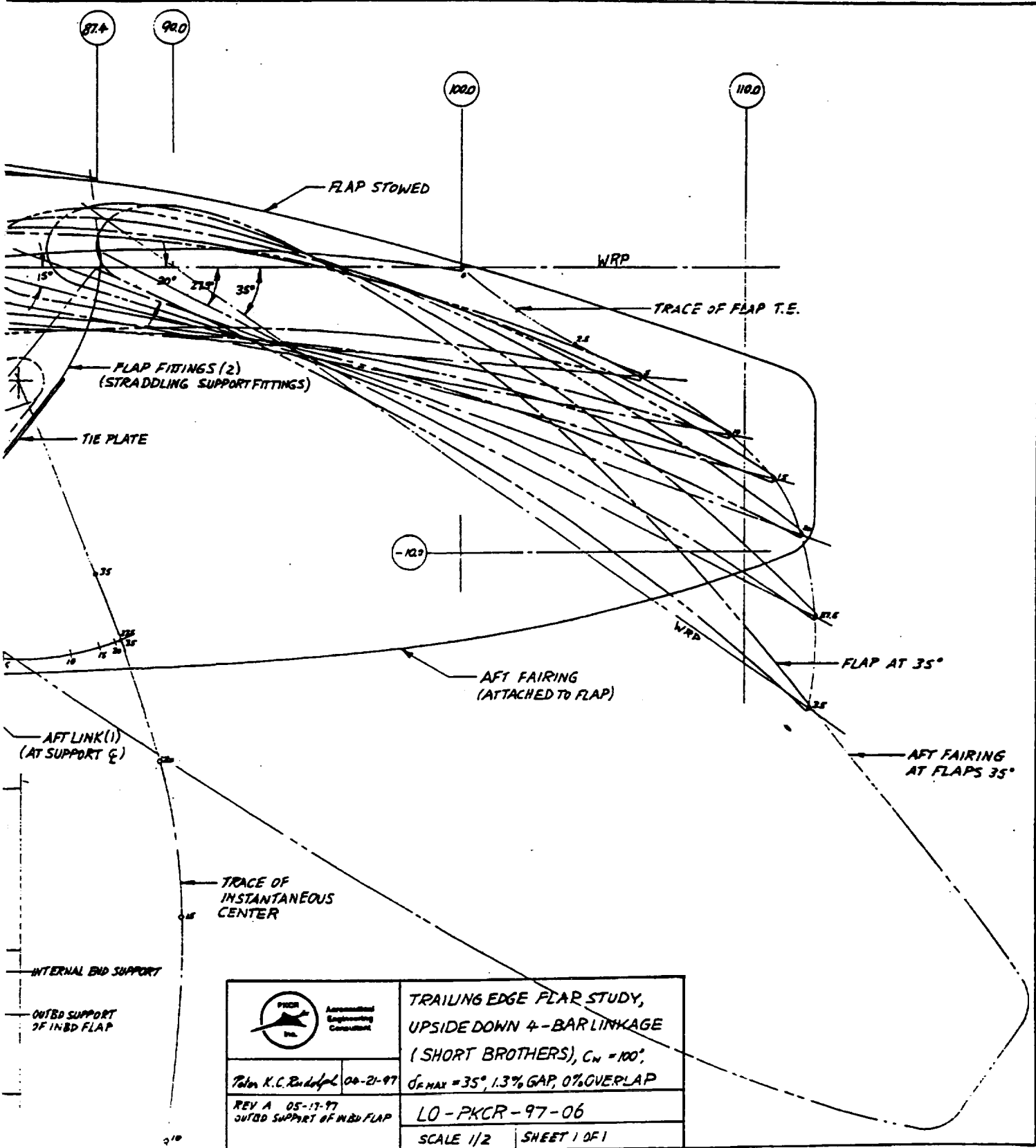



Figure 7 Short Brothers T

1  
2  
3  
4  
5  
6  
7  
8  
9  
10  
11  
12  
13  
14  
15  
16  
17  
18  
19  
20  
21  
22  
23  
24  
25  
26  
27  
28  
29  
30  
31  
32  
33  
34  
35  
36  
37  
38  
39  
40  
41  
42  
43  
44  
45  
46  
47  
48  
49  
50  
51  
52  
53  
54  
55  
56  
57  
58  
59  
60  
61  
62  
63  
64  
65  
66  
67  
68  
69  
70  
71  
72  
73  
74  
75  
76  
77  
78  
79  
80  
81  
82  
83  
84  
85  
86  
87  
88  
89  
90  
91  
92  
93  
94  
95  
96  
97  
98  
99  
100





 Aeromedical Engineering Consultant	<b>TRAILING EDGE FLAP STUDY,          UPSIDE DOWN 4-BAR LINKAGE          (SHORT BROTHERS), <math>C_w = 100'</math></b>	
	Peter K.C. Biedel 00-21-97	$\delta_{fl. MAX} = 35^\circ, 1.3\% \text{ GAP}, 0\% \text{ OVERLAP}$
REV A 05-17-97 OUTSD SUPPORT OF INBD FLAP	LO-PKCR-97-06	
	SCALE 1/2	SHEET 1 OF 1

# Type Upside Down Four Bar Linkage

This page is intentionally blank.

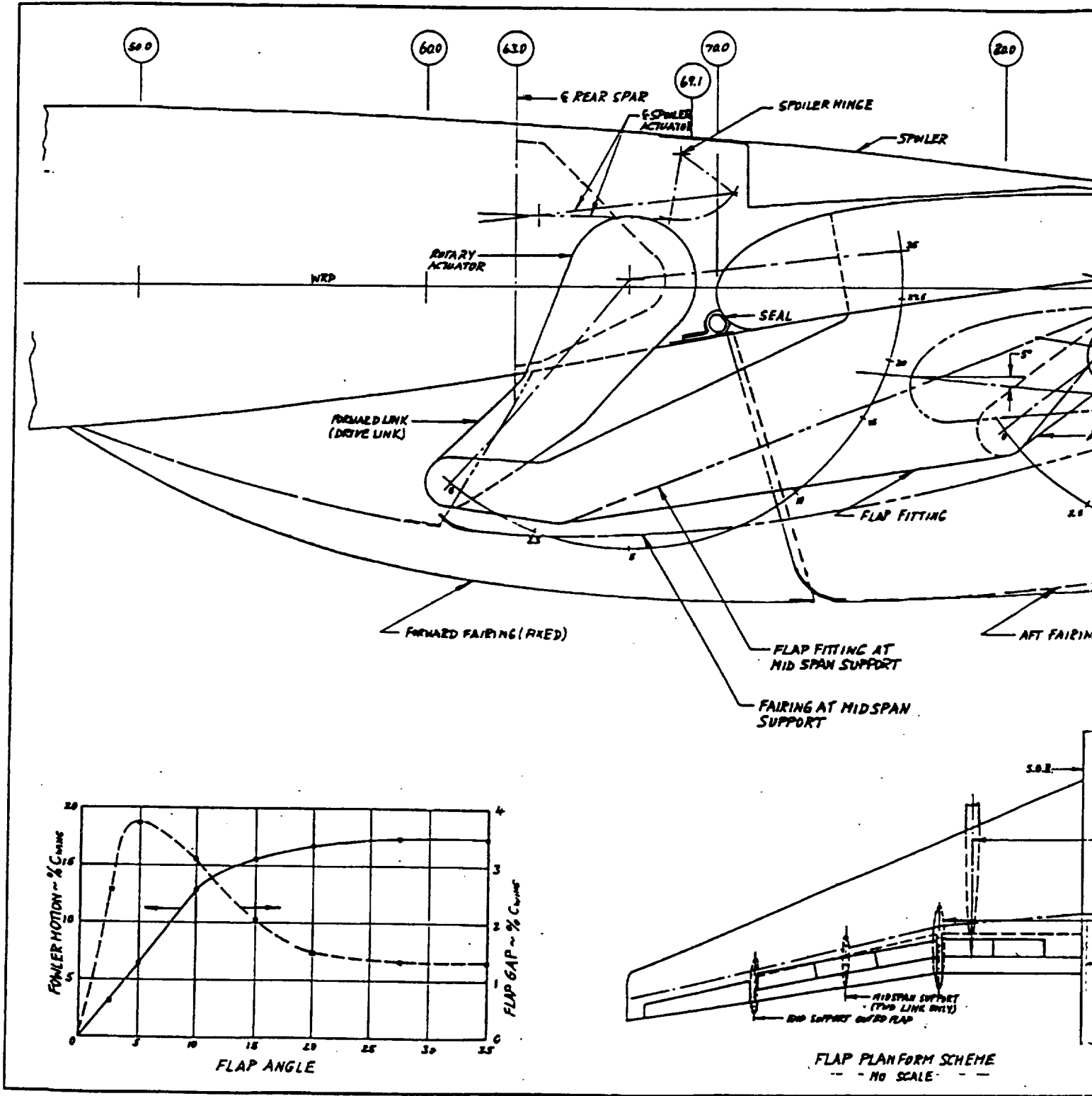
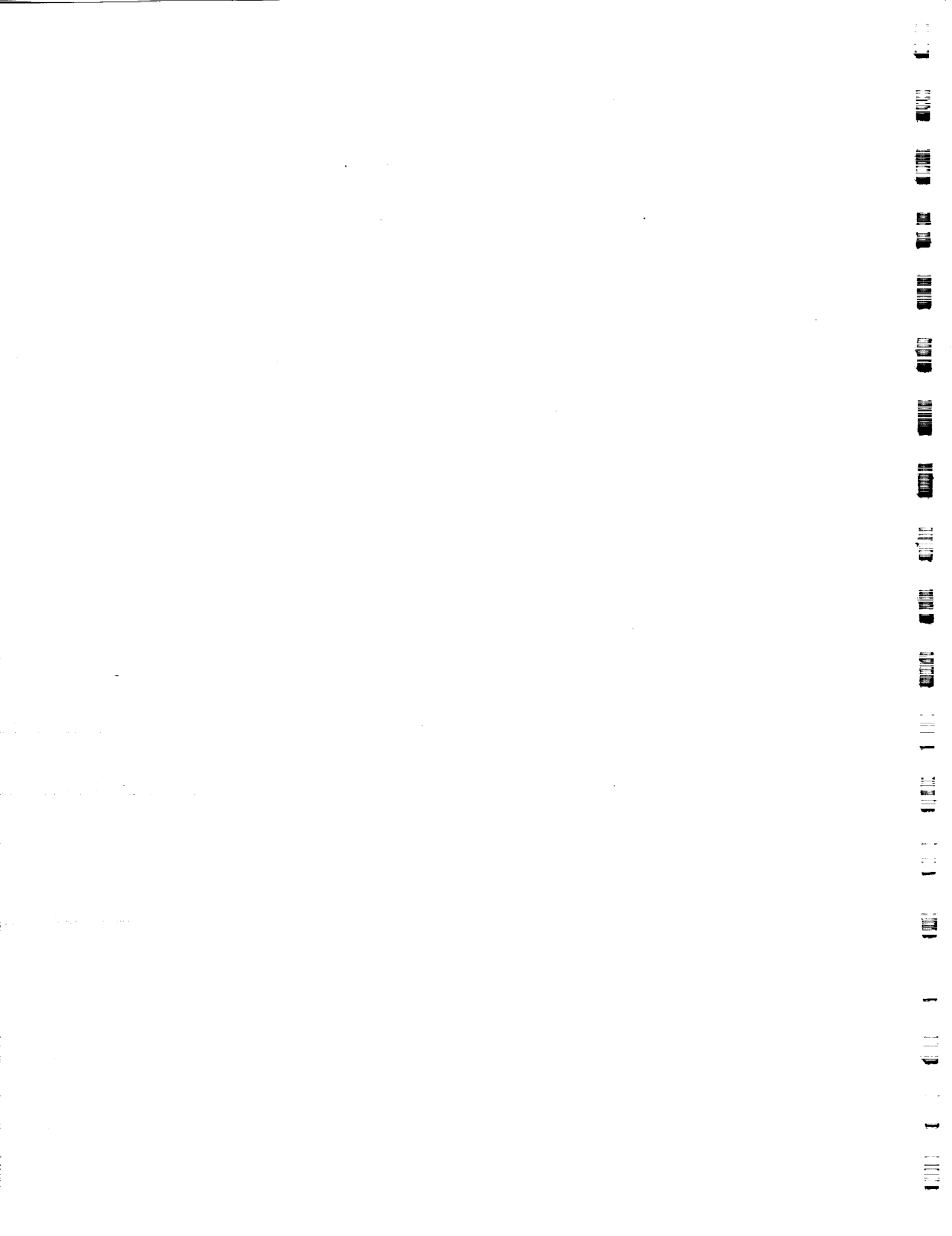
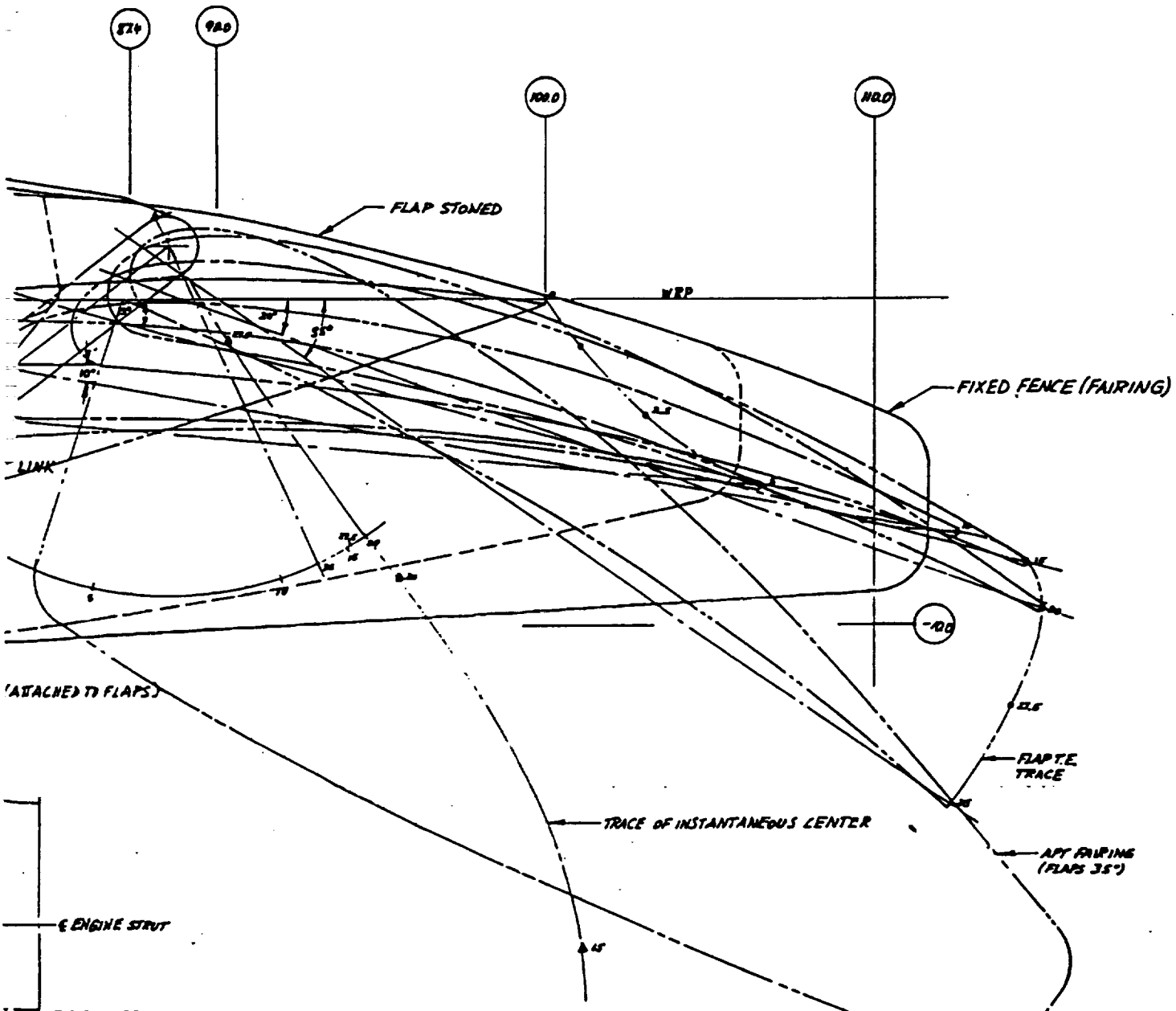



Figure 8 Boeing





END SUPPORT FOR INNER & OUTER FLAPS INTERNAL END SUPPORT	 Purdue University Department of Aeronautical Engineering West Lafayette, Indiana		<b>TRAILING EDGE FLAP STUDY,          UPSIDE-DOWN 4-BAR LINKAGE          (747 SP TYPE WITH END SUPPORTS)</b>	
	REV. K.L.P. 05-17-97	R.L.R. 05-17-97	$C_w = 100^\circ$ , $\delta_F \text{ MAX} = 35^\circ$ , 1.3% GAP, 0% OVERLAP	
	REV. A 05-17-97 R.L.R. ADDED ENGINE STRUT		<b>LO-PKCR-97-04</b>	
	REV. B 10-18-97 K.L.P. MODIFIED AFT FAIRING/FENCE		SCALE 1/2	SHEET 1 OF 1

**747 Type Four Bar linkage**

**This page is intentionally blank.**

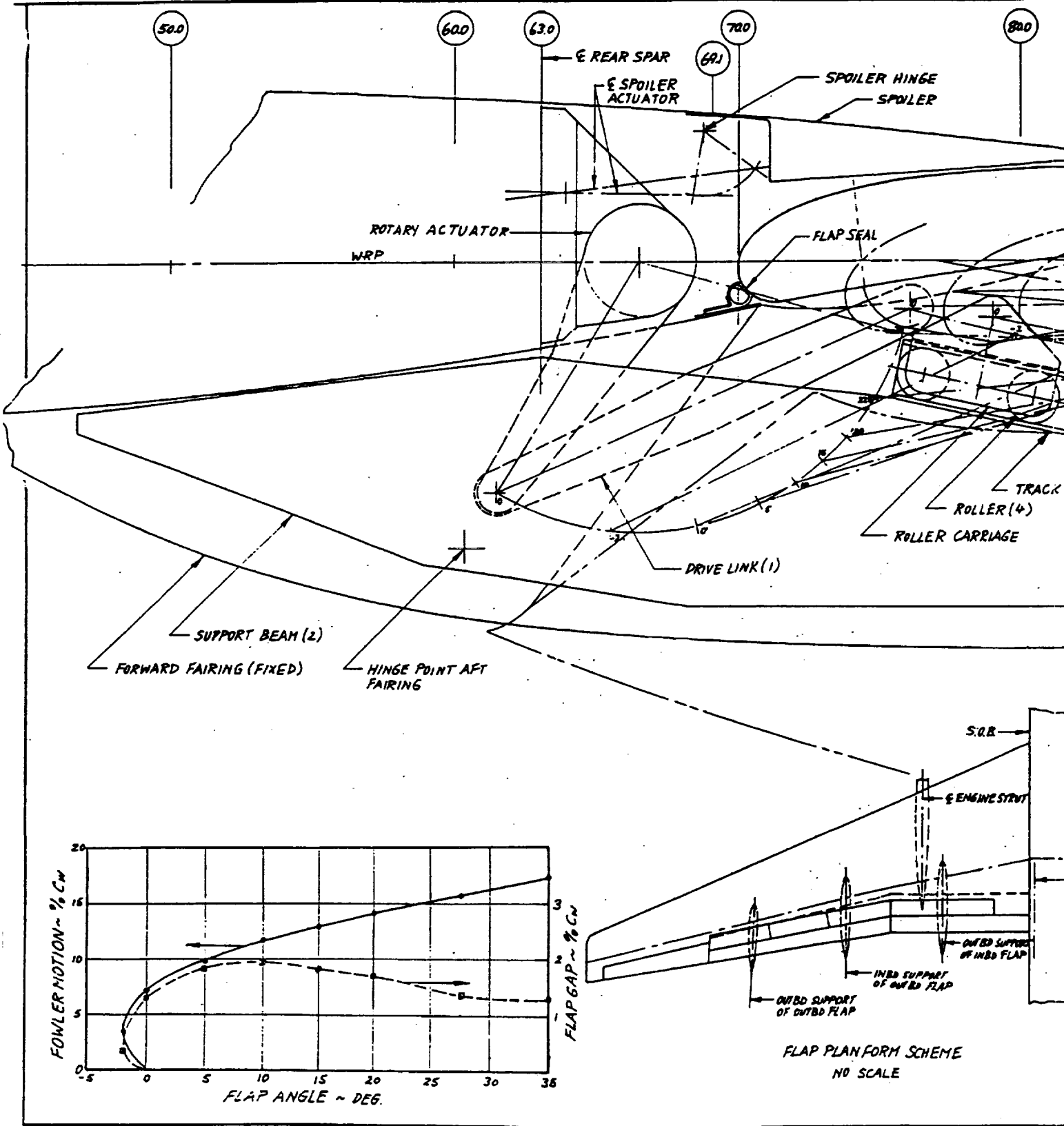
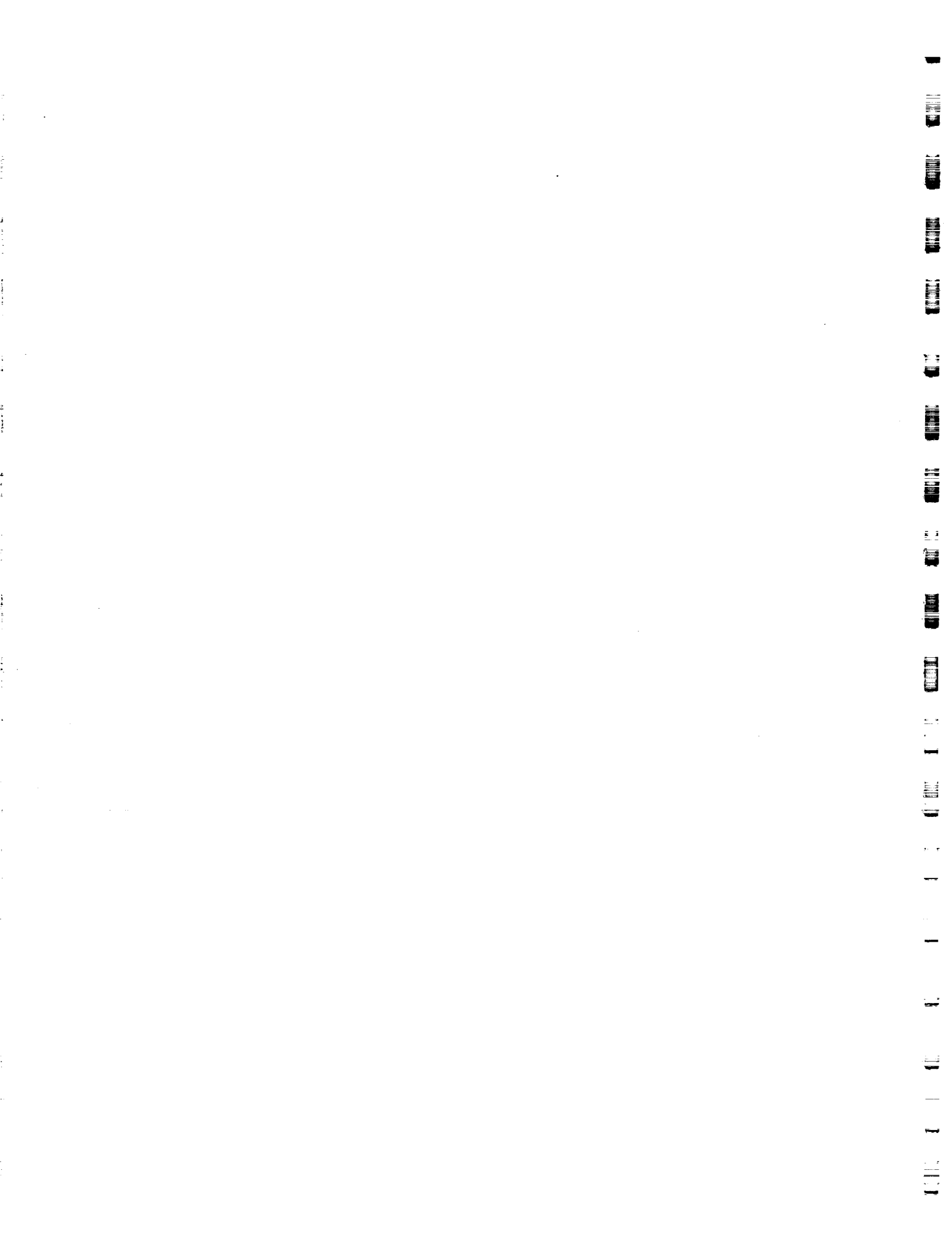
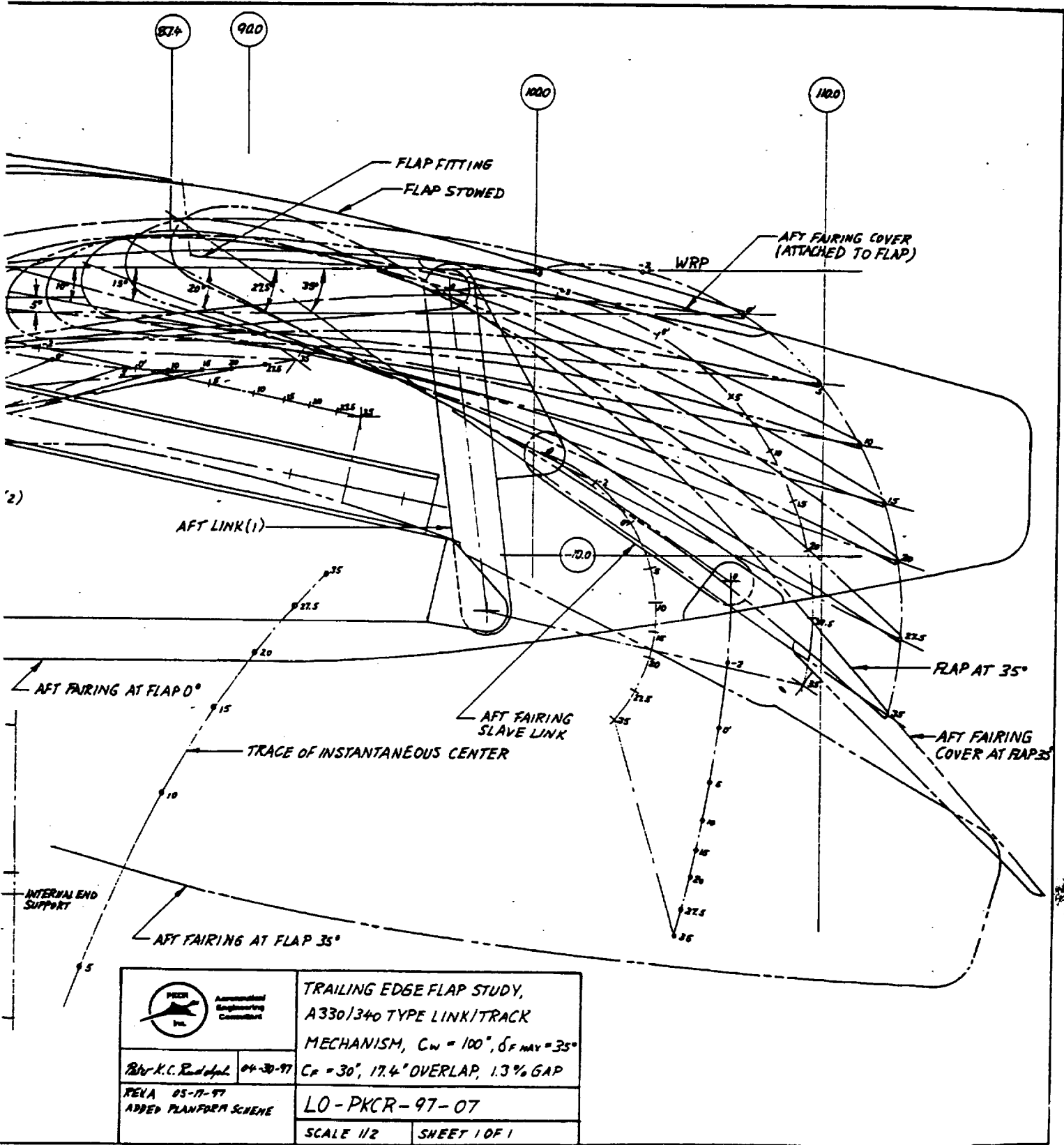



Figure 9

Airbus A330/3







 PKCR Aeronautical Engineering Consultants	TRAILING EDGE FLAP STUDY, A330/340 TYPE LINK/TRACK MECHANISM, $C_w = 100^\circ$ , $\delta_F \text{ MAX} = 35^\circ$	
	By K.C. Radtke 04-30-97	$C_F = 30^\circ$ , 17.4" OVERLAP, 1.3% GAP
KEVA 05-17-97 ADDED PLANFORM SCHEME	LO-PKCR-97-07	
	SCALE 1/2	SHEET 1 OF 1

# 40 Type Link/Track Mechanism

**This page is intentionally blank.**

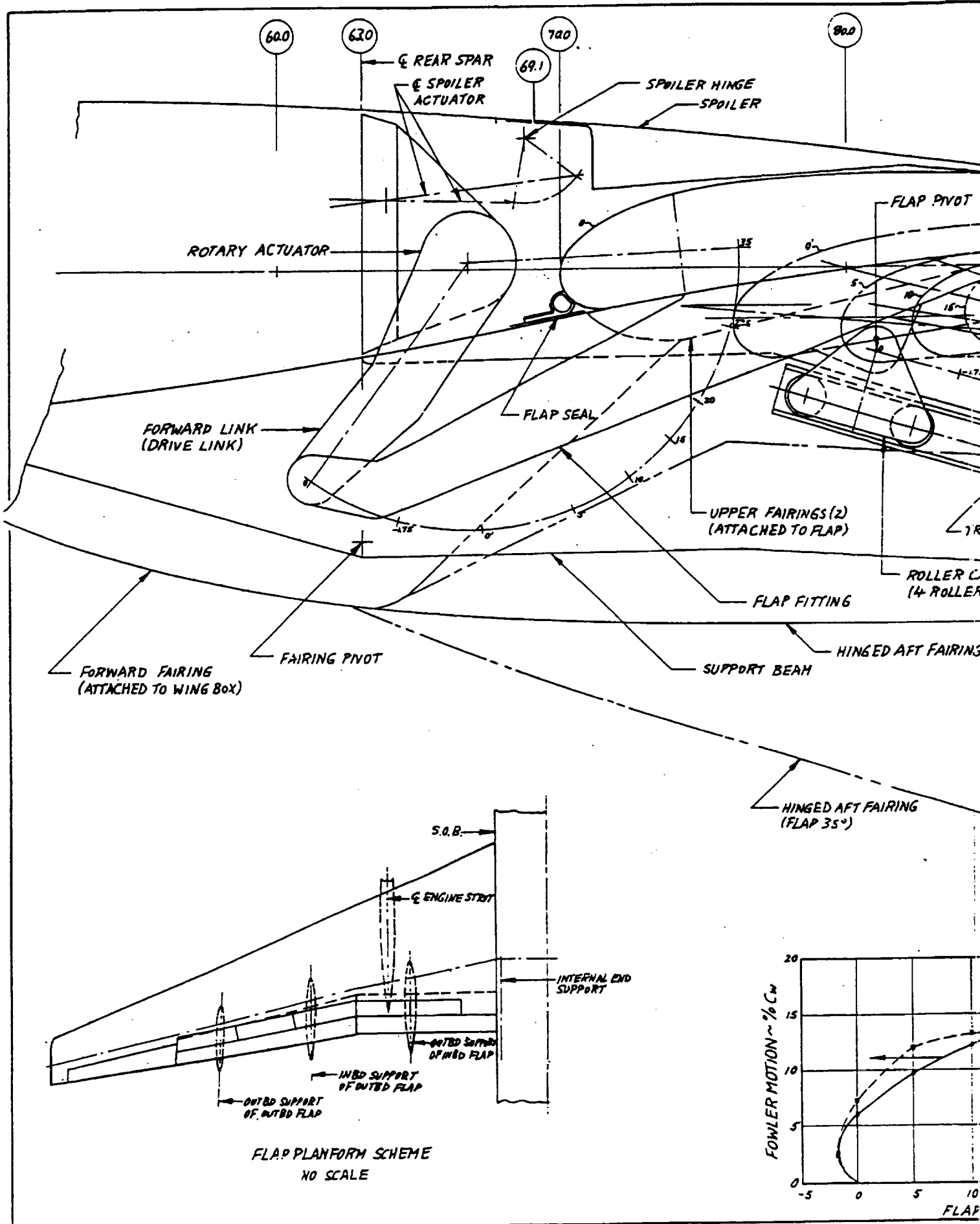
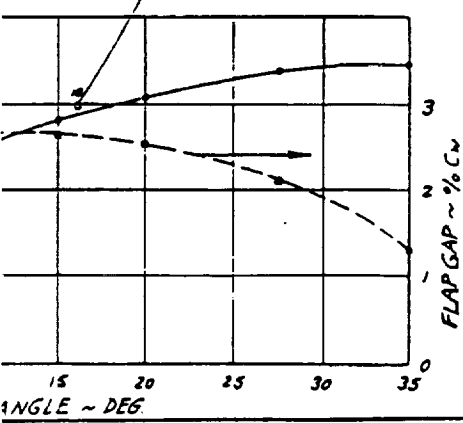
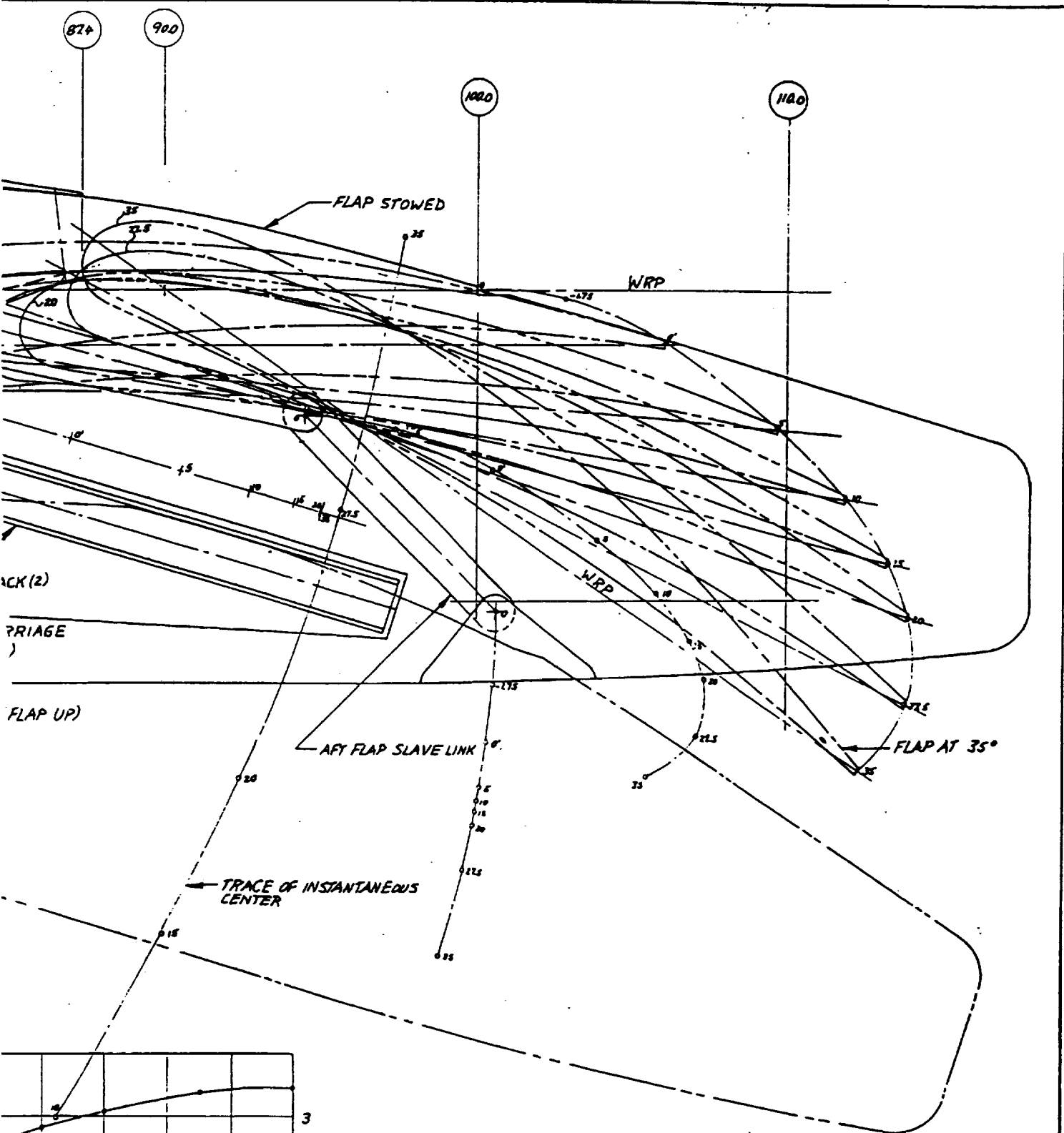



Figure 10

Airbus A320  
(Conservat





 Aeromedical Engineering Consultant	TRAILING EDGE FLAP STUDY, A 320 LINK/TRACK MECHANISM WITH TWO SUPPORTS UNDERNEATH, $C_w = 100, \delta_{PMW} = 35^\circ, 17.4\% \text{ MAX.}$ FOWLER MOTION, 1.3% GAP, 0% OVERLAP	
	Peter K.C. Rindley, L 01-06-97	LO-PKCR-97-14 SCALE 1/2 SHEET 1 OF 1

0) Type Link/Track Mechanism  
ve)

**This page is intentionally blank.**

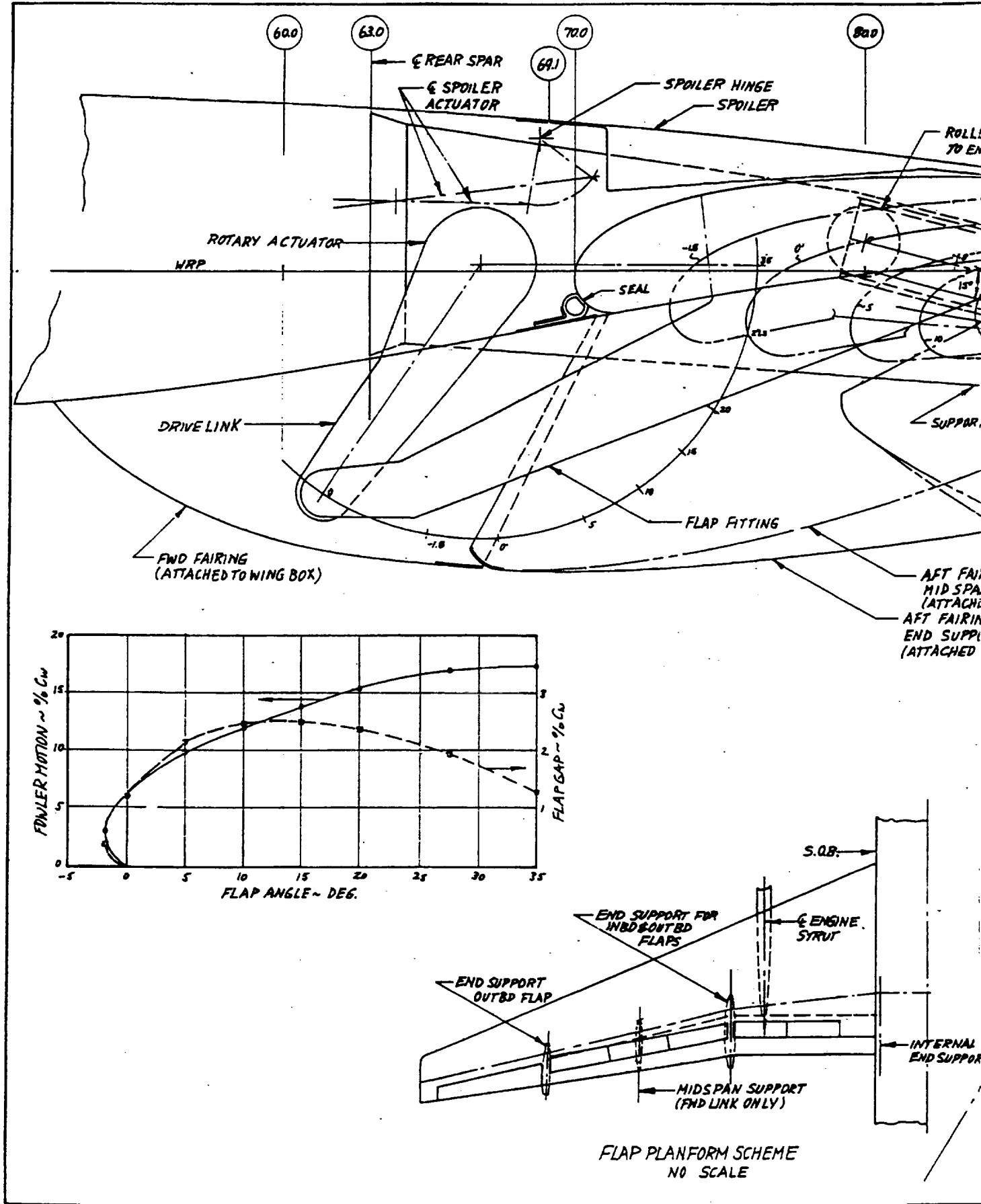
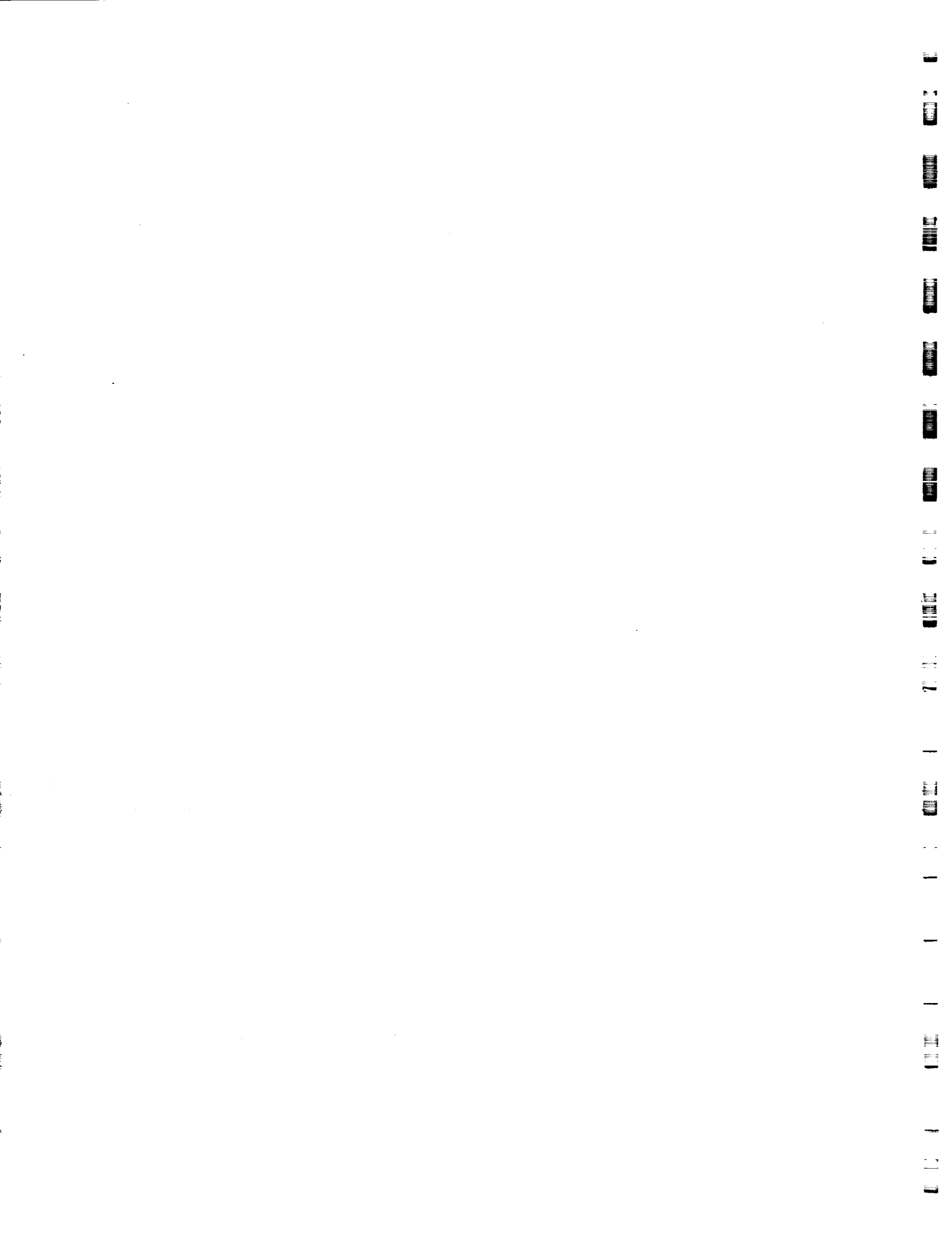
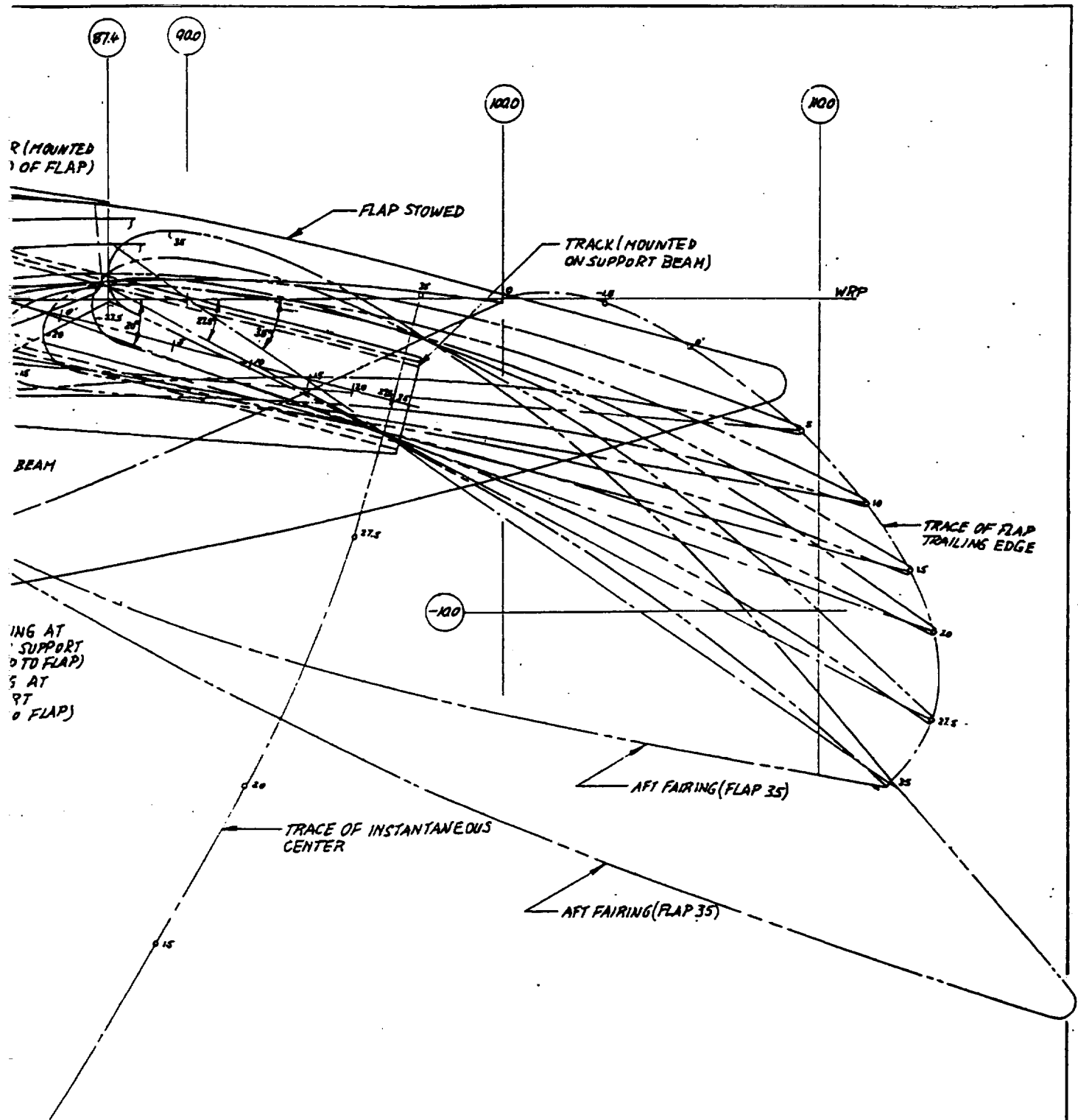



Figure 11

Airbus A320  
(End Support)







 Associated Engineering Consultant	<b>TRAILING EDGE FLAP STUDY,          A 320 TYPE LINK/TRACK MECHANISM          WITH END SUPPORT,  <math>C_w = 100^\circ</math>, <math>\delta_F \text{ MAX} = 35^\circ</math>, 1.3% GAP,          0% OVERLAP, 17.4% MAX FOULER MOTION</b>		
	<i>John R.C. Rudolph</i>	85-20-97	<b>LD-PKCR-97-10</b>
		SCALE 1/2	SHEET 1 OF 1

320 Type Link/Track Mechanism  
(Mounted)

**This page is intentionally blank.**





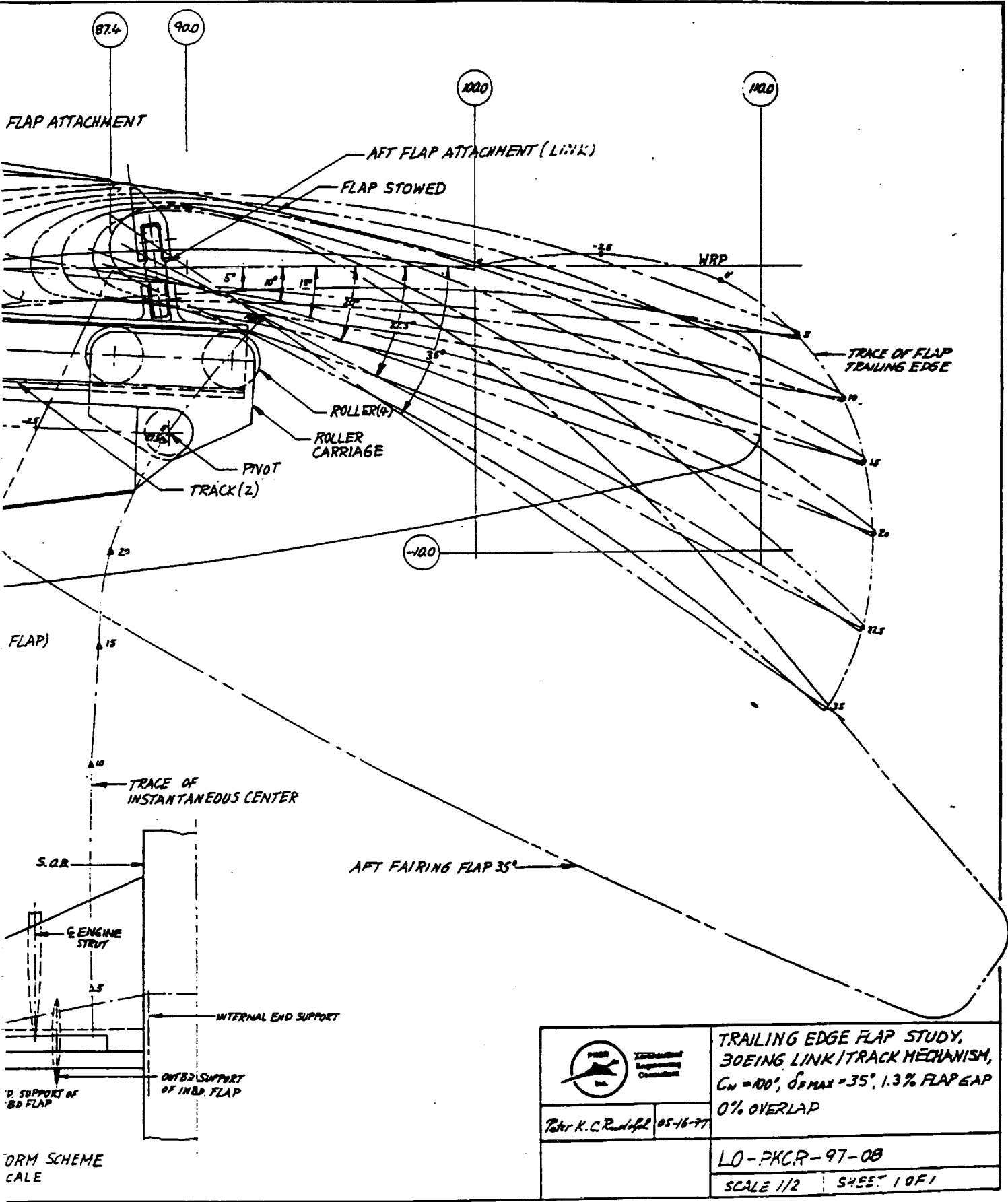

type Link/Track Mechanism  
 (Active)

**This page is intentionally blank.**

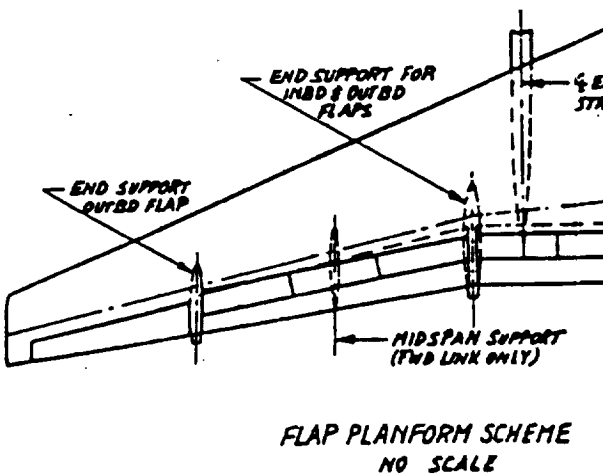
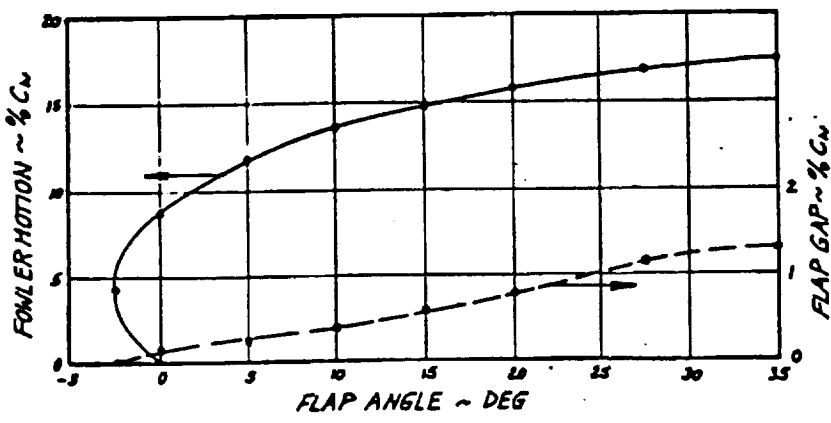
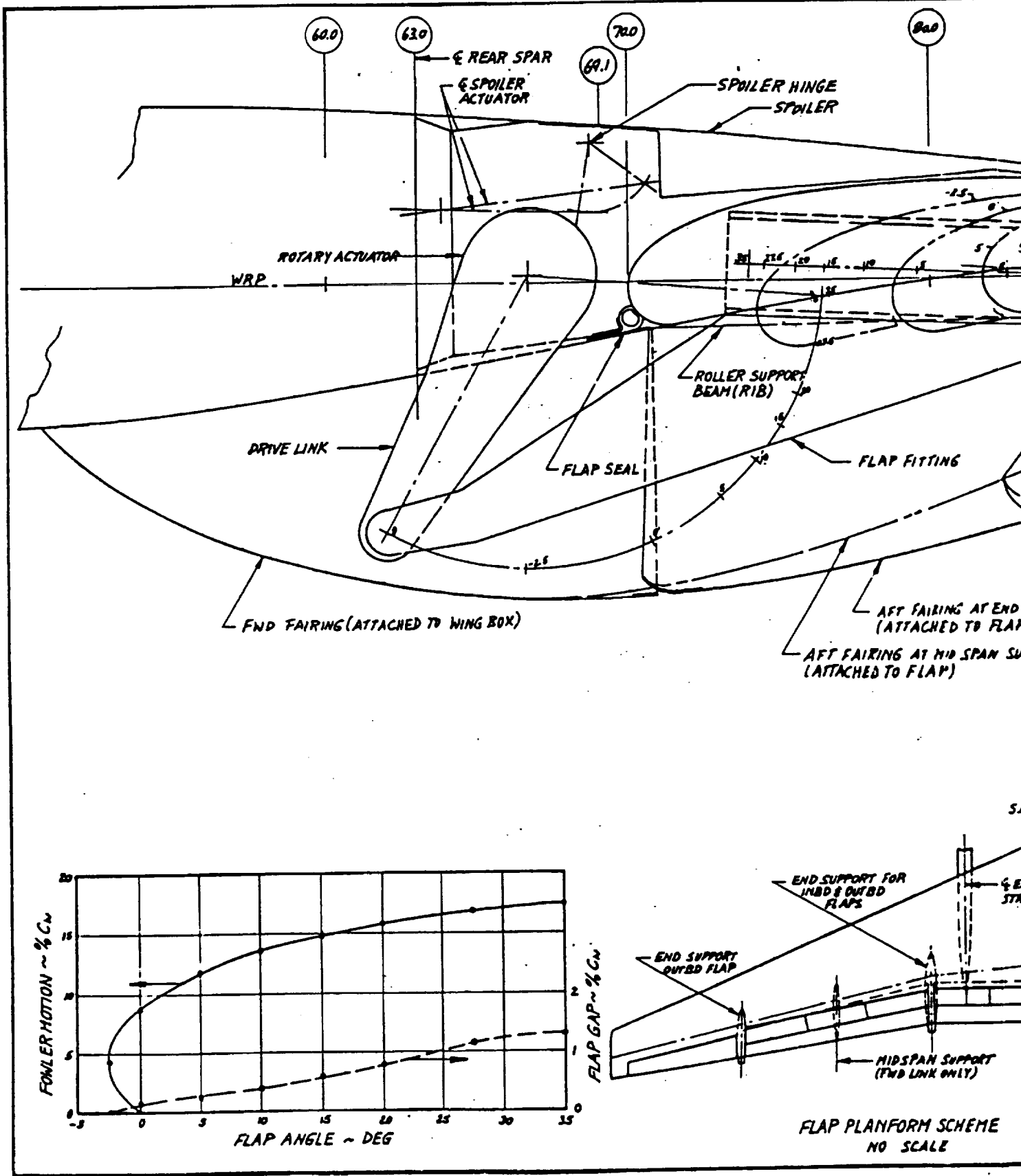
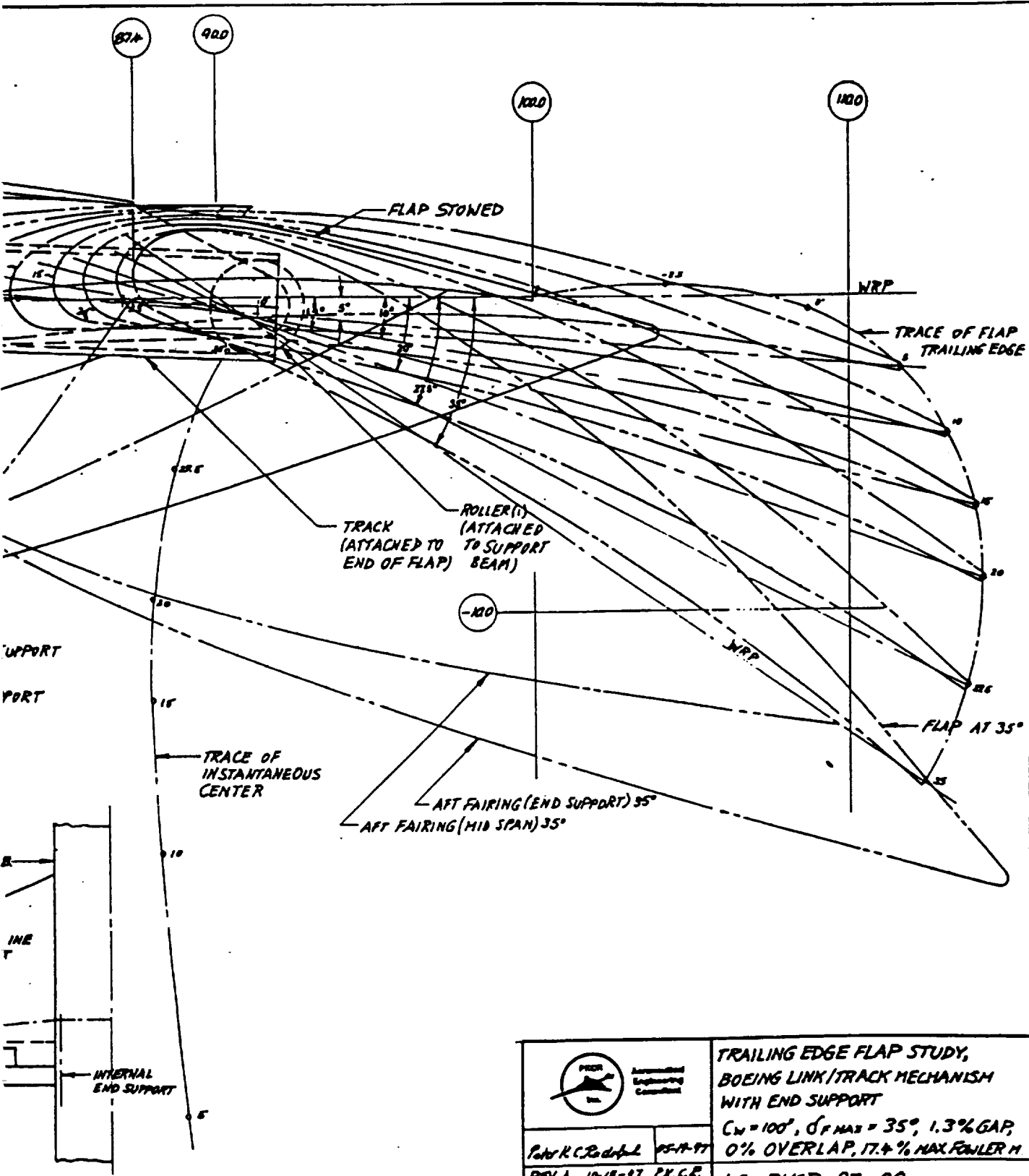



Figure 13 Boeing (End S







 PKCR Aerospace Engineering Consultant	<b>TRAILING EDGE FLAP STUDY,          BOEING LINK/TRACK MECHANISM          WITH END SUPPORT</b>	
	$C_w = 100'$ , $\delta_f \text{ MAX} = 35^\circ$ , 1.3% GAP, 0% OVERLAP, 17.4% MAX FOWLER H	
PKCR REV. A 10-18-97 P.K.C.R. MODIFIED ROLLER SUPPORT BEAMS	05-11-97	<b>LO-PKCR-97-09</b>
SCALE 1/2	SHEET 1 OF 1	

Type Link/Track Mechanism  
 (supported)

**This page is intentionally blank.**

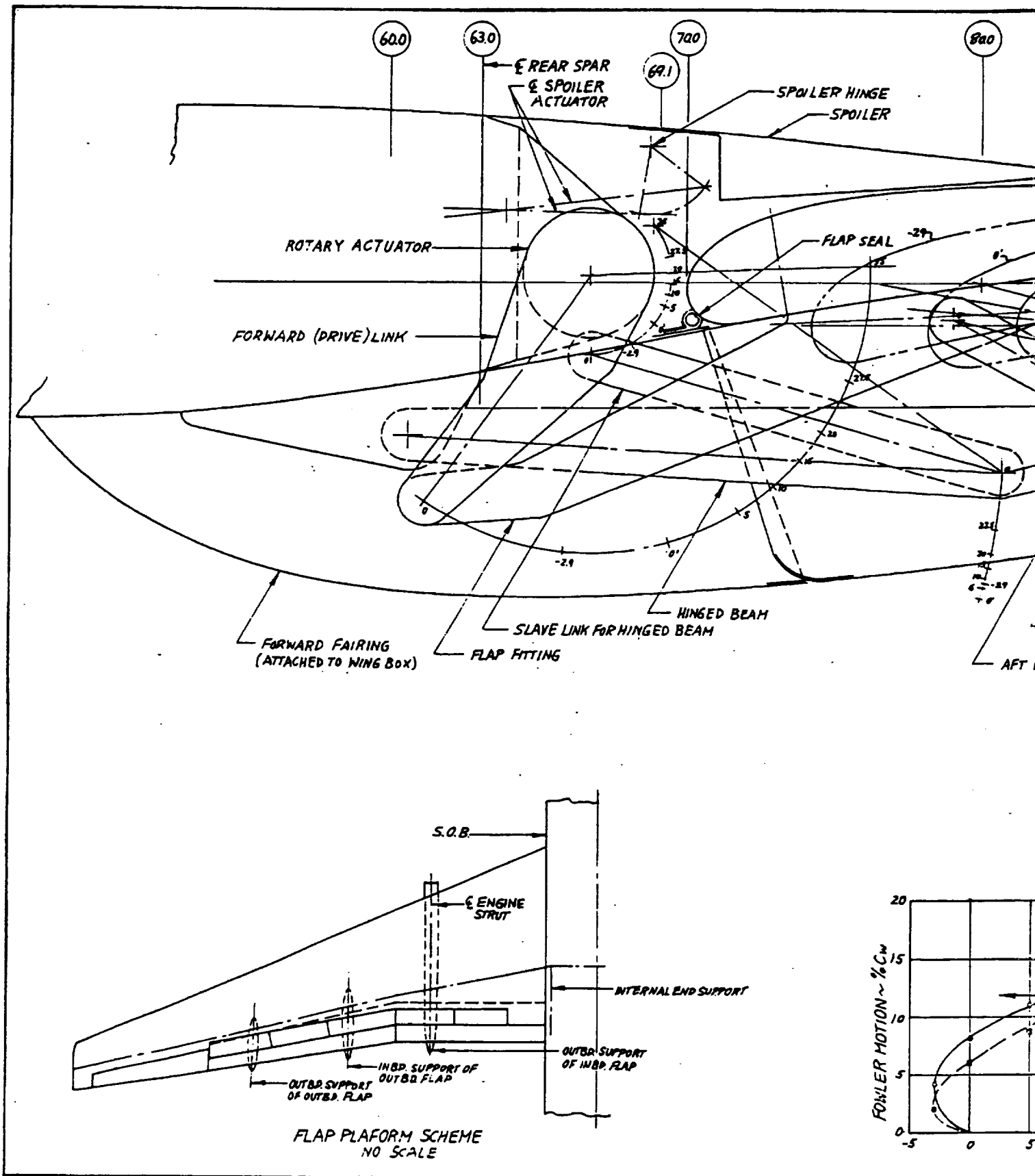
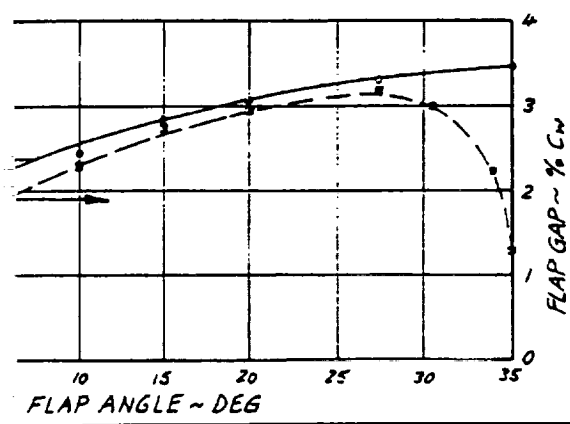
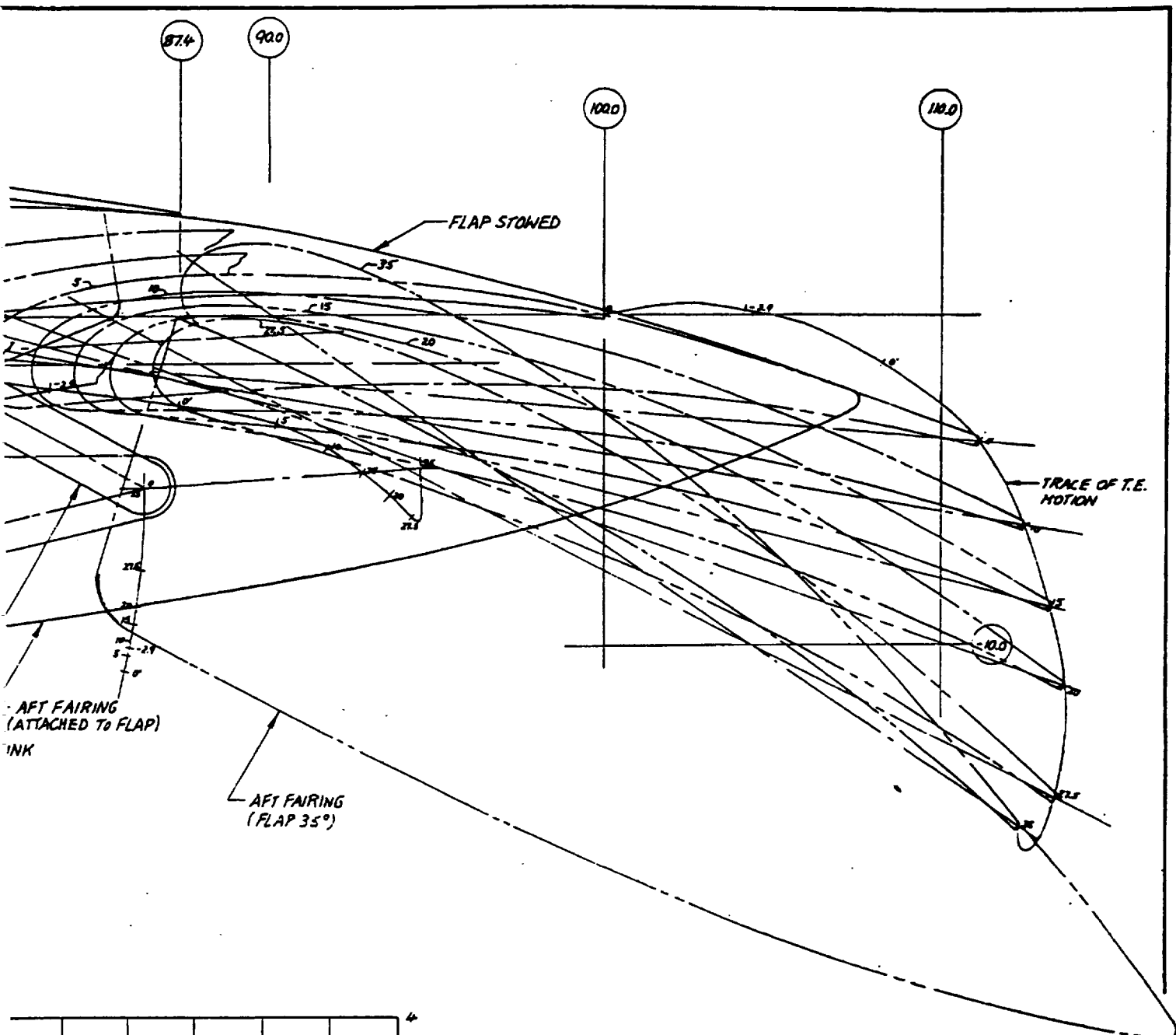



Figure 14 Boeing 767 Ty





 Accredited Engineering Consultant	<b>TRAILING EDGE FLAP STUDY, BOEING 767 HINGED BEAM TYPE LINKAGE WITH TWO SUPPORTS UNDERN.</b>	
	$C_w = 100^\circ$ , $C_f = 30$ , $\delta_{fmax} = 35^\circ 17.4\%$ MAX. FOWLER MOT., 1.3% GAP, 0% OVERL	
By K.C. Radford	NS-27-97	<b>LO-PKCR-97-15</b>
		SCALE 1/2 SHEET 1 OF 1

**pe Hinged Beam Four Bar Linkage**

**This page is intentionally blank.**

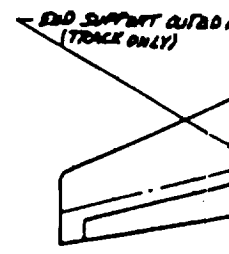
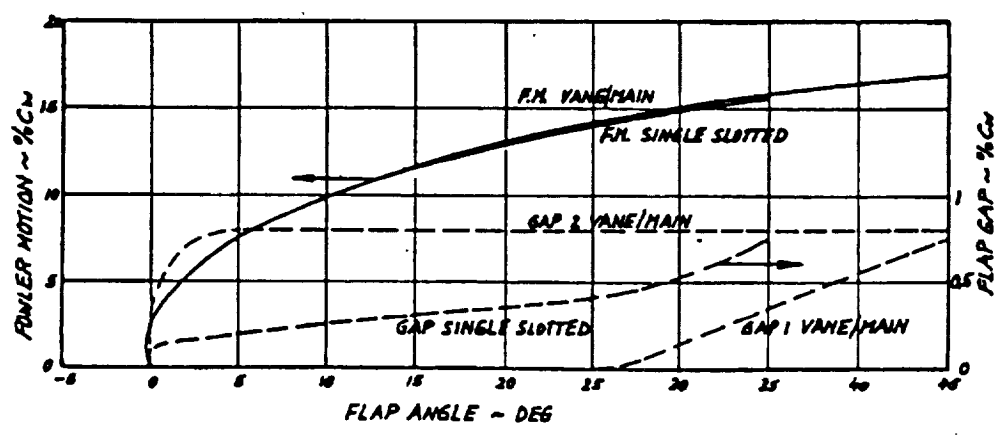
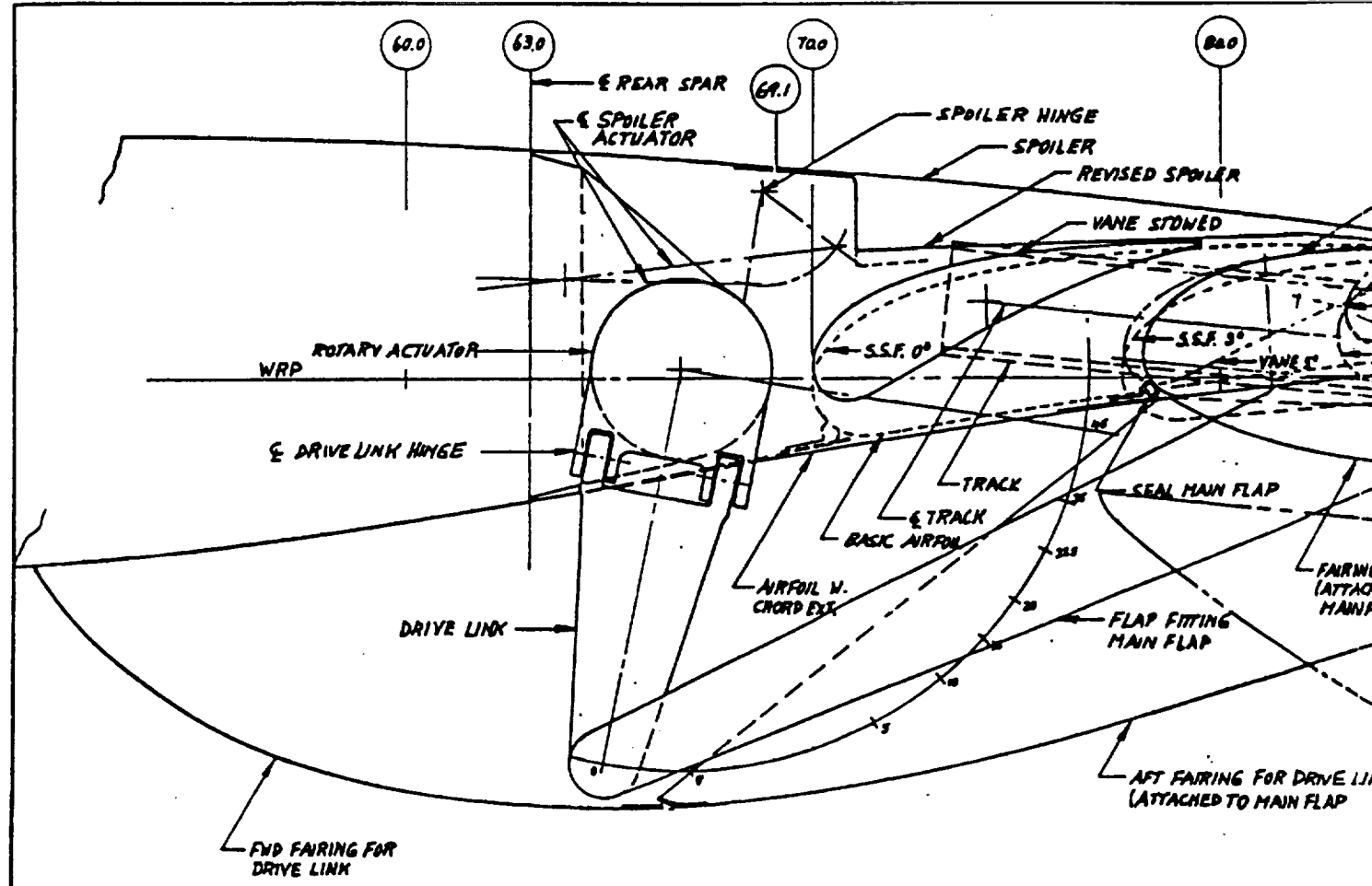
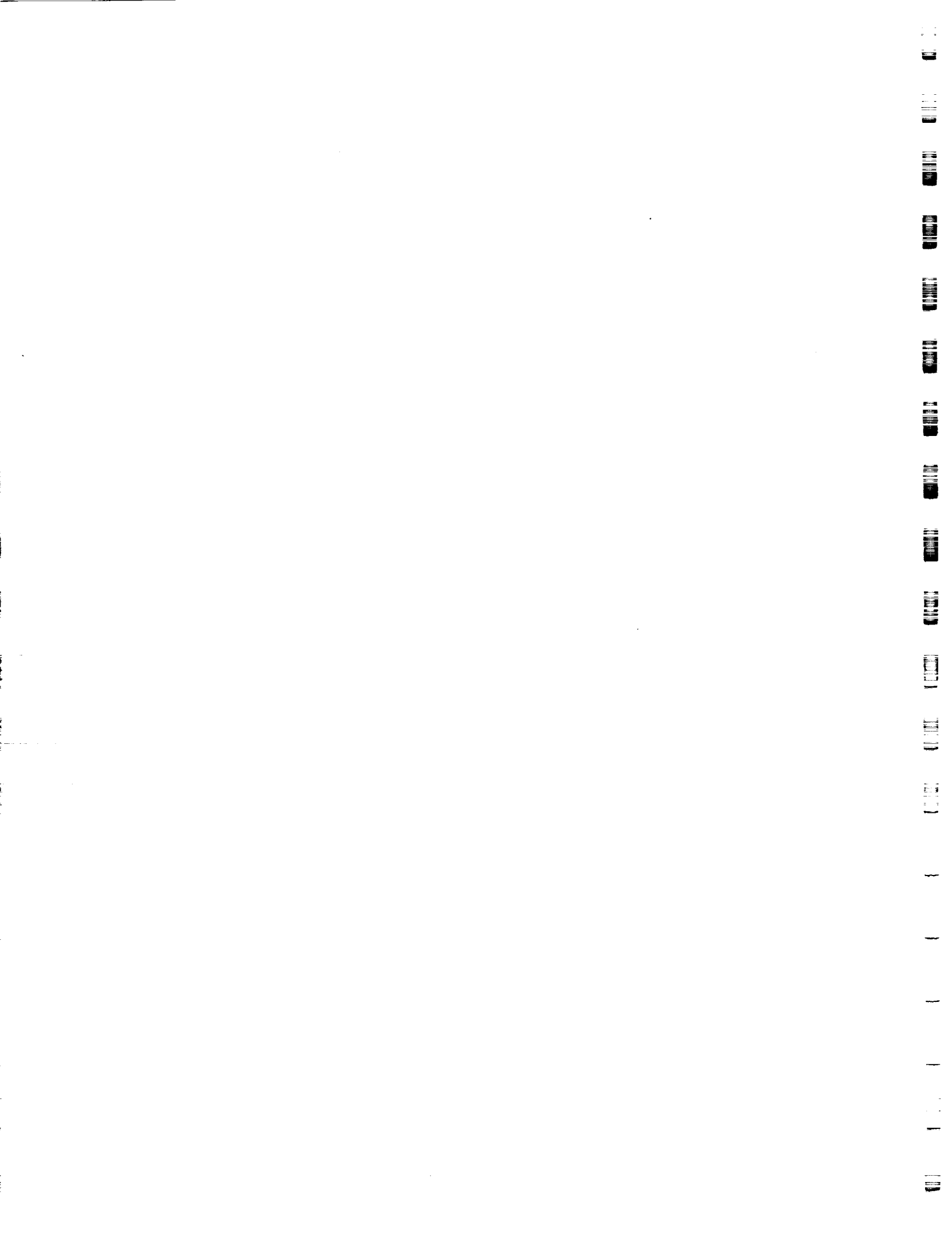
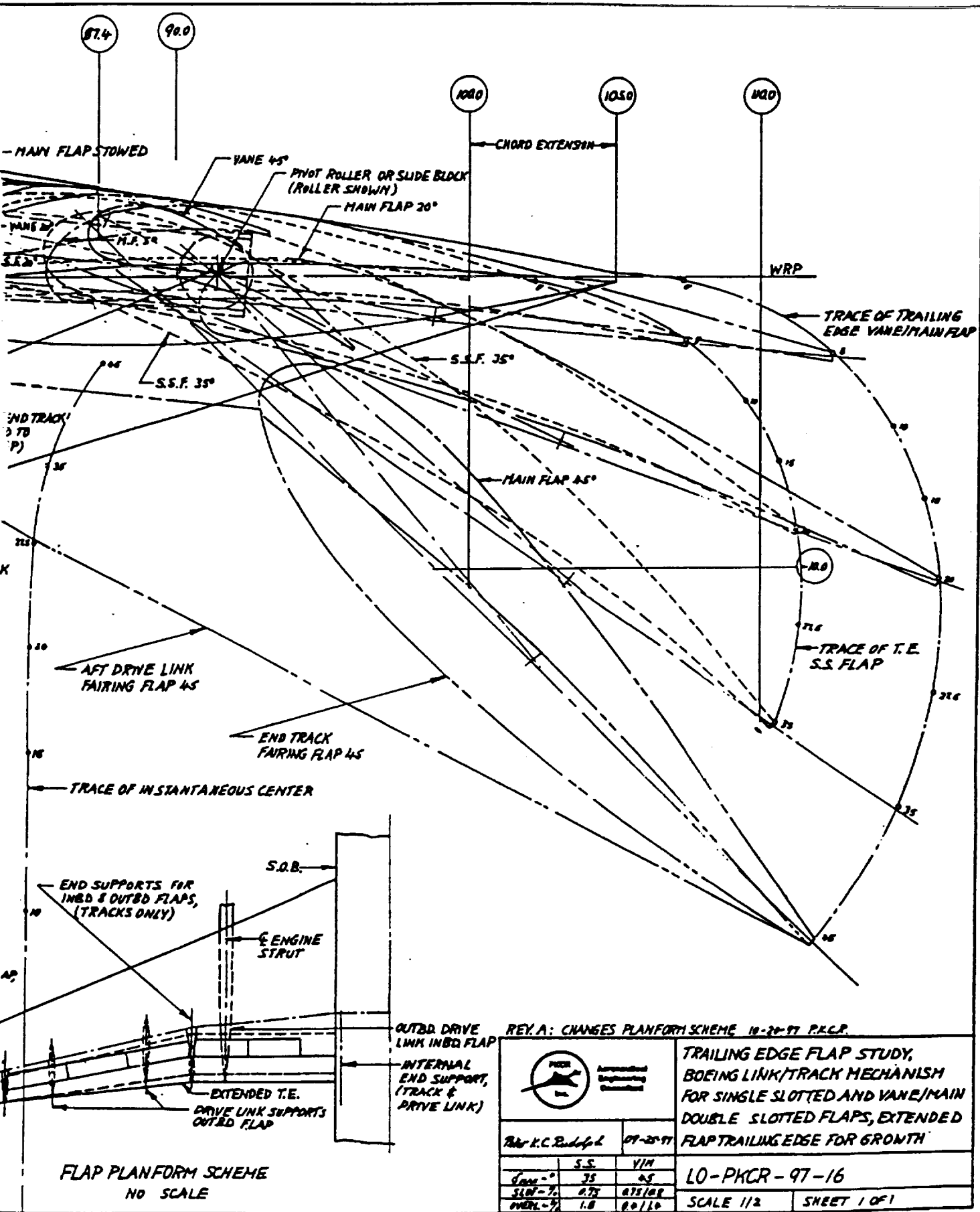

Figure 15 Single and Vane/ with End Support







# Main Double Slotted Flap Boeing Link/Track Mechanism

**This page is intentionally blank.**

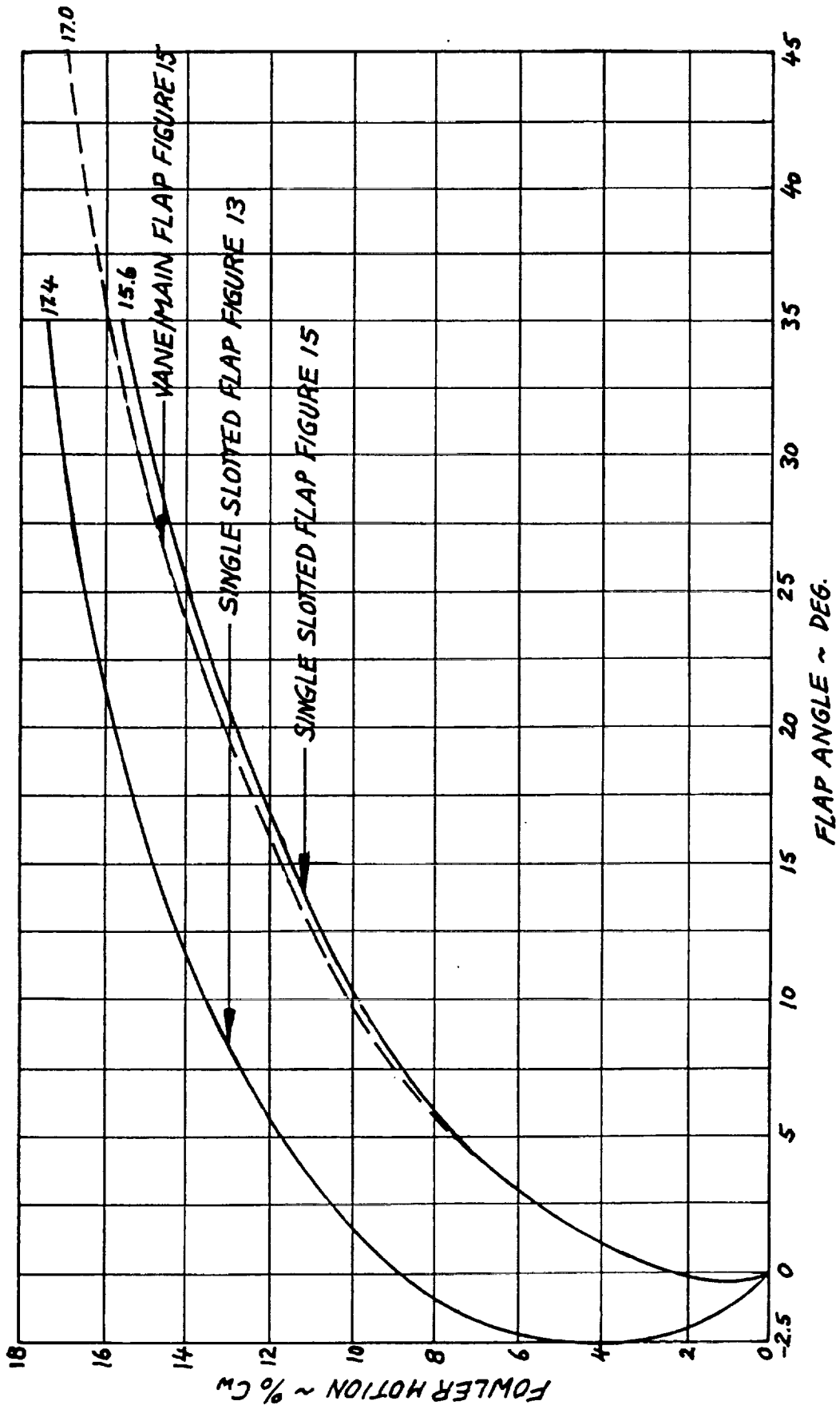
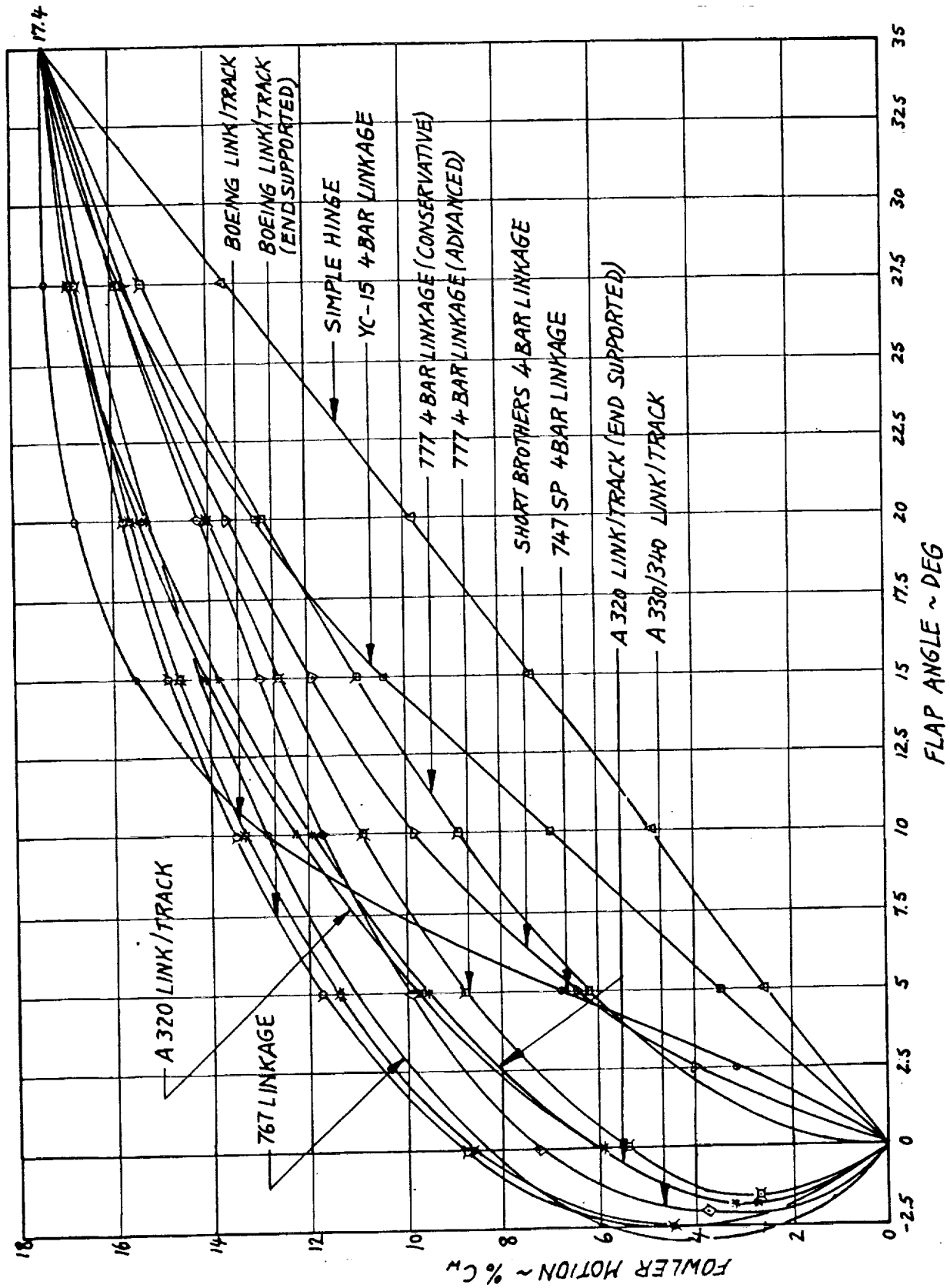

Figure 16 Fowler Motion Comparison for a Vane/Main Single Slotted Flap



Rev 1 of 28-97  
08-24-97  
P.K.C.R.

Figure 17 Fowler Motion Progression Comparison

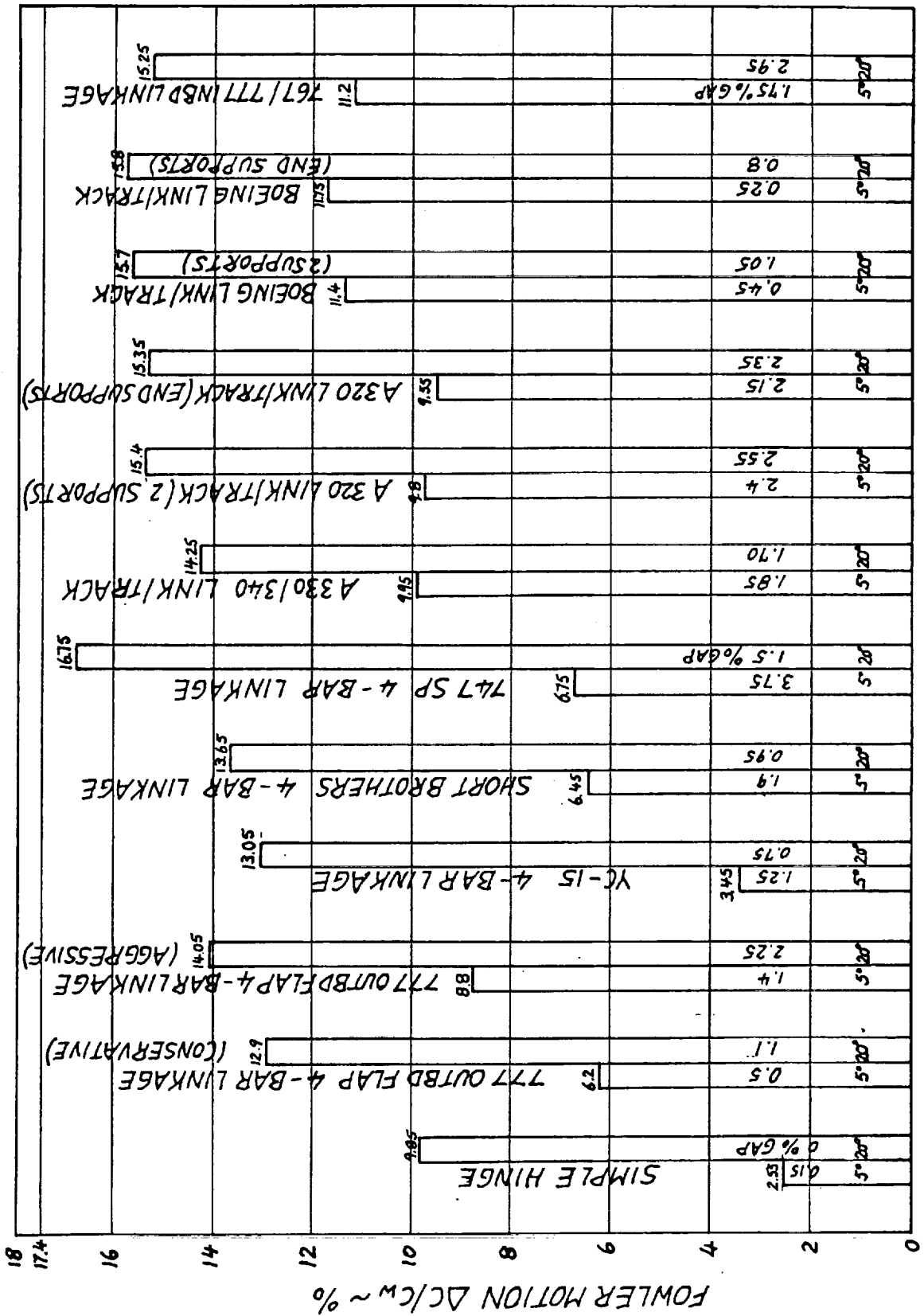
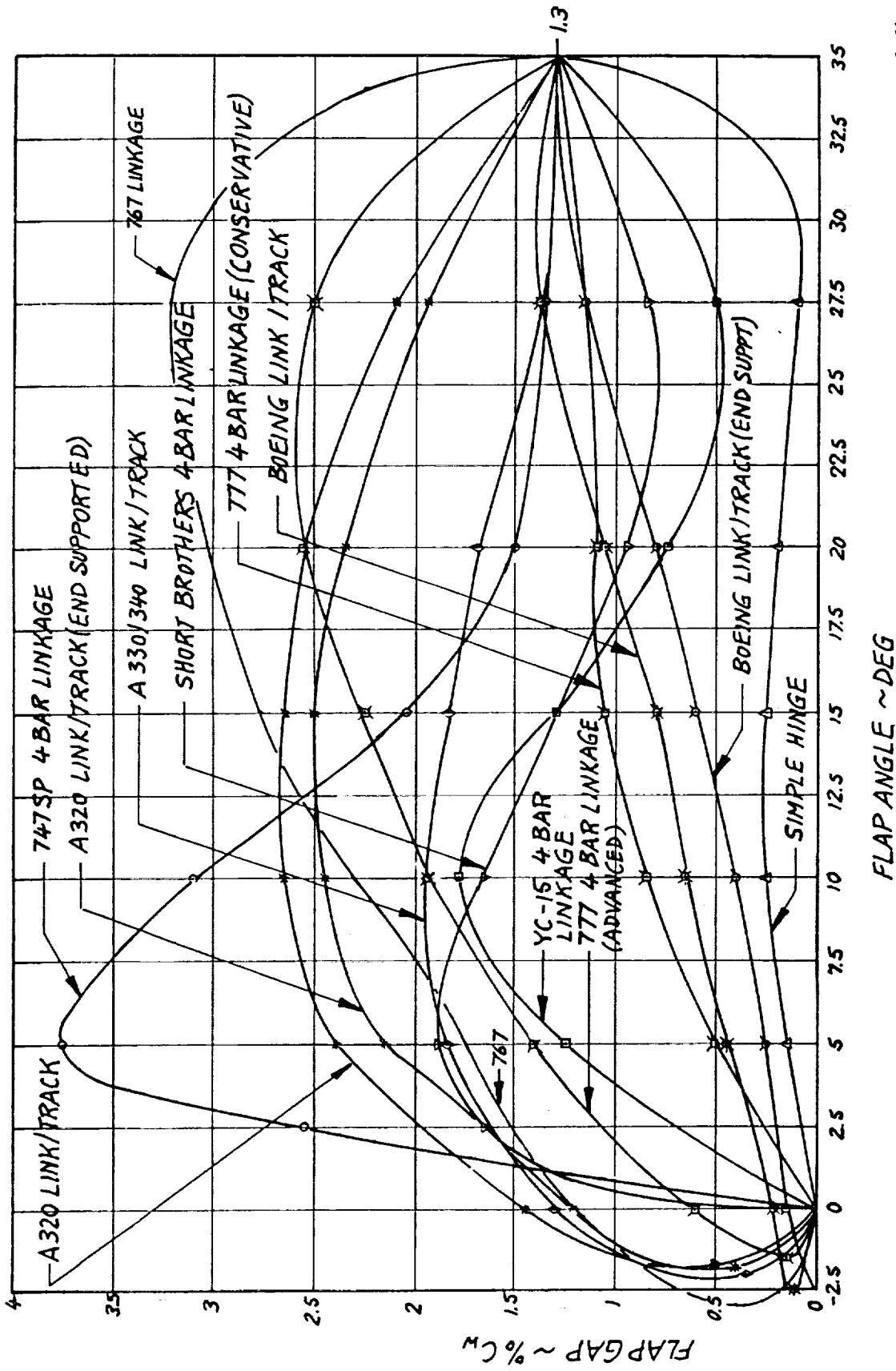

Figure 18 Fowler Motion Comparison for Takeoff



08-24-97  
P.K.C.R.  
REV 1 08-28-97

Figure 19 Flap Gap Development Comparison







## PART II. FEASIBILITY OF A SHALLOW SLAT

### 1.0 Background

There is a general consensus in the aircraft industry worldwide that the lightest and least expensive trailing edge flap is the single slotted flap. All aircraft manufacturers have made attempts to improve the single slotted flap and to make it meet the high lift requirements for takeoff and landing. A lot of these attempts did not succeed. The single slotted flap does not produce as high a lift increment as a double slotted flap, but this can generally be accepted. The biggest challenge with the single slotted flap is to stay within the airplane attitude requirements, which is particularly difficult for a growth airplane with stretched fuselage.

Figure 1, taken from NASA Contractor Report 4746 (ref. 1), illustrates this attitude deficiency of the single slotted flap. Depending on the type of airplane (wing incidence angle, aft fuselage length, etc.) this deficiency can be between 1° or 3°. The reference 1 report suggests that the most efficient way to cure the attitude problem may be with a shallow slat having a large slot. Such a configuration has been analyzed and tested by Swedish aerodynamicist Björn Ljungström (refs. 2 & 3). Figures 2 and 3 are taken from Ljungström and they show the lift versus alpha curves for two different slat deployment angles, and the optimum slot gaps for different slat angles, respectively. There appears to be a 1° shift in the alpha curve to the left when going from a slat angle of 20° to 15°. If this relationship is linear over some distance, a 3° shift in the alpha curve to the left could be obtained by going from a typical slat angle of 30° to a 15° slat angle. However, this change in slat angle requires an increase in slot size from 2% to 4%. It should be recognized that all of Ljungström's data are for low Reynolds numbers. At full scale Reynolds numbers the optimum slot sizes may be somewhat smaller. But the question arises whether there are realistic and simple slat mechanisms that can achieve these slat positions with larger slots. This report summarizes the results of a design effort on this subject.

### 2.0 Discussion

#### 2.1 Boeing 757 Baseline Slat With Slave Links

The Boeing 757 leading edge slats use the rack and pinion drive for the mechanization of slats. This was the

first design of this kind done by the Boeing Company, and it has proven to be a most successful design concept and has been copied repeatedly. Therefore, it is chosen as the baseline and starting point for this study. Figure 4 shows a section along the main track of the most outboard support location of a wing similar in size and shape to the 757. This design does not exactly represent the 757 outboard slat support, but it is the best effort of the contractor to duplicate it.

The Boeing 757 has three position slats with a stowed, a takeoff, and a landing position. The slat is not rigidly attached to the main track and it can rotate relative to the main track. This rotation is accomplished with slave tracks. The schematic of such a slave track is shown in the little insert picture in figure 4. The use of slave tracks was considered necessary in order to accomplish a sealed takeoff slat position without compromising the landing configuration.

The circular arc track has a centerline radius of about 26.2 inches and travels through an arc of a little less than 28°, which is the maximum slat angle for landing. The track cross section is shaped like the Greek letter "π" and it cuts through the front spar when the slat is retracted. The rack, which is located in between the two vertical flanges of the track and is attached to them, is in engagement with the pinion that is driven by the slat rotary actuator. To preserve the integrity of the fuel tank, a track-can that surrounds the stowed track is bolted to the backside of the front spar. The best location for the track penetration through the front spar is near the middle of the spar web, that is, the neutral axis for wing/spar bending. Another design criterion is the proximity of the track-can to the lower surface of the wing box. While the wing box skin on the outboard wing may be only 3/4 to 1 inch thick honeycomb, the track-can has to clear wing stringers as deep as, say, 2.5 inches farther inboard. The 757 design meets all of the above criteria very nicely.

The slat airloads, the largest portion normal to the track and with only a small overturning moment relative to the slat pivot, are reacted from the track into the leading edge ribs through two roller couples. The upper forward and the lower aft rollers react the higher slat up-loads, while the lower forward and the upper aft rollers react the smaller slat down-loads. The rollers are sized accordingly. It is important to maximize the moment couples between the up and down load roller couples to reduce roller loads. Also, the forward of the two rollers should be as far forward as possible to reduce the moment from airloads on the slat. On the 757 type design, the couple between the upload rollers is 10.1 inches and 7.9 inches for the download rollers.

For takeoff, the slat is in a sealed position, and it has rotated to a 20° angle.

## 2.2 28° Slat Without Slave Links

Airbus and lately even Boeing on their 777 airplane have managed to eliminate the auxiliary tracks. They create extra weight and cost and cause additional flow disturbance upstream of the slat slot which will degrade the slat high lift performance. Airbus does not try to seal the slot for the takeoff position and claims that the drag penalty for this is minimal at flight Reynolds numbers. Boeing, on the 777 airplane, seals the slat for the takeoff position and shows what appears to be a compromised landing position with a very small slot and steep slot convergence.

The contractor made an attempt to design a slat without slave links that deploys to a landing angle of 28° with a 2.2% slot. It turned out that this is not possible within the confines of the 757 outboard wing contours. With the rack and pinion drive arranged as on the 757 (from below the track), the track extends too high to allow sufficient room for the forward upload roller. Conversely, when the actuation is from the top, there is insufficient room for the forward download roller below the track, and the aft end of the track in its stowed position almost penetrates the wing box lower surface (no picture shown).

## 2.3 Slats with 20°, 15°, and 10° Maximum Deployment Angles Without Slave Links

Slats with maximum deployment angles of 20° and to as low as 10° are possible with a rack and pinion drive without slave links if the actuation is moved above the track. Figure 5 shows two sections through a 757 type slat track at the aft roller location with the actuation below and above the track. The above track actuation is a possible arrangement for shallow slats. It should be recognized that the width of the track is determined by the roller with the highest load. This will be the forward upload roller that runs on the track upper flange. The tracks for the shallow slats have the opening for the rack on the upper track flange, and therefore lose about 0.6 inches in roller contact length. This has to be made up with an increase in overall width.

### 2.3.1 Slat with 20° Maximum Deployment Angle

Figure 6 shows a layout for a slat with 20° maximum deployment angle without slave links. The wing section is identical to that used to show the Boeing 757 outboard slat support (fig. 4). Wing chord is 80 inches, slat chord is 19.75 inches (24.7% of wing chord) and the slat slot in the landing configuration is chosen at 2.4 inches, or

3% of wing chord. The takeoff slat angle is assumed to be 14°, with the slat slot as a fall-out at 1.35 inches, or 1.75% of wing chord.

The slat is attached to the track with two bolts and thus cannot rotate. A slat angular adjustment capability (link) may be required in lieu of one of the bolts. The track is open at the top and houses the rack with the actuator and pinion above the track. The radius of the track centerline is 33.85 inches. The moment couple for the upload rollers is 10.3 inches, which is a little longer than the 757 configuration. The moment couple for the download rollers is 7.35 inches, which is 0.5 inches less than the 757 configuration. But this is not a fatal flaw. The aft end of the track in the stowed position comes very close to the surface of the lower wing box skin. This is a serious problem. However, it can probably be handled with a local thinning of the outboard honeycomb panel, and by designing the system to a larger clearance going inboard so that the track cans do not interfere with the spanwise wing skin stringers. The track penetrates the fixed leading edge a little bit closer to the slat gap than on the 757 configuration which may increase the blockage effect slightly.

In summary, there are no obvious show stoppers for this slat configuration.

### 2.3.2 Slat with 15° Maximum Deployment Angle

Figure 7 shows a layout for a slat with 15° maximum deployment angle without slave links. The wing section is identical to that used to show the Boeing 757 outboard slat support (fig. 4). Wing chord is 80 inches, slat chord is 19.75 inches (24.7% of wing chord) and the slat slot in the landing configuration is chosen at 2.4 inches, or 3% of wing chord. The takeoff slat angle is assumed to be 10° with the slat slot as a fall-out at 1.25 inches, or 1.56% of wing chord.

The 15° slat is very similar in concept to the 20° slat. Track radius is 45.1 inches and the upload roller couple is again 10.3 inches. The download roller couple has improved a little to 7.5 inches, which is 0.4 inches less than the 757 configuration. The slat track penetrates the front spar web almost perfectly in the middle, and the end of the track-can is sufficiently far above the lower wing box skin to not cause clearance problems with the wing stringers farther inboard. The track penetrates the fixed leading edge almost exactly at the same location as does the 20° slat.

In summary, the 15° slat with a 3% gap has no obvious show stoppers and actually seems to go together a little easier than the 20° slat. Designing the 15° slat for 3.5%

or even 4% gaps, as the Ljungström data suggests, seems to be possible.

### 2.3.3 Slat with 10° Maximum Deployment Angle

Figure 8 shows a layout for a slat with 10° maximum deployment angle without slave links. The wing section is identical to that used to show the Boeing 757 outboard slat support (fig. 4). Wing chord is 80 inches, slat chord is 19.75 inches (24.7% of wing chord) and the slat slot in the landing configuration is chosen at 3.2 inches, or 4% of wing chord. The takeoff slat angle was assumed to be 7°, with the slat slot as a fall-out at 1.8 inches, or 2.25% of wing chord.

The 10° slat is very similar in concept to the 15° and 20° slats. Track radius is 64.1 inches, and the upload roller couple is reduced to 9.8 inches. The download roller couple has improved a little more to 7.75 inches which is 0.15 inches less than the 757 configuration. The slat track penetrates the front spar web quite low, and the end of the track-can has a marginal clearance from the lower wing box skin to not cause clearance problems with the wing stringers farther inboard. This is better than for the 20° slat, and a little worse than for the 15° slat. The track penetrates the fixed leading edge closer yet to the slat slot. Therefore, it is possible that the slat performance may suffer somewhat.

In summary, the 10° slat with a 4% gap has no obvious show stoppers. It goes together a little easier than the 20° slat and a little harder than the 15° slat. The proximity of the track to the slot is of concern. Increasing the slot from 4% to 5% or more, as Ljungström's data suggests, is probably not possible with this concept.

### 2.4 Other Configuration Options

This feasibility study was conducted using Boeing 757 slat design technology in a very narrow sense. There are other configuration options available. Most of them pose no higher risks, but they require a change in design philosophy. Some other options may increase weight or cost slightly, but they may still be acceptable if they make the shallow slat feasible.

The A320 has slats without slave tracks that deploy to a maximum angle of 24° using the rack and pinion drive with the actuation from below. This would not lead to a viable solution with the 757 roller arrangement (see section 2.2). Instead of using separate up and down load rollers as Boeing does, Airbus is using the same rollers for up and down loads by letting them ride in between the track flanges. Airbus has used this approach successfully on the A310 trailing edge flaps. The rollers inside the

track would require a somewhat deeper track and larger rollers to compensate for the fact that the rollers are cantilevered off the leading edge ribs. This will downgrade their allowable stresses. But, this approach will maximize the length of the roller couple. Figure 9 shows a cross section of such a track/roller arrangement.

Another constraint imposed by the Boeing 757 type rack and pinion drive on the configuration is the limited choice in track vertical location. The actuation can be either from the top or from the bottom but nowhere in between. If the screw jack drives of the Airbus A300 and A310 slat actuation is accepted as a viable solution, more freedom in placing the track into the best vertical location is gained. The same effect can be achieved with the Airbus A330/340 inboard slat drive using rotary actuators with a drive arms (fig. 10). As a last resort, one could go back to slave tracks to achieve the larger gaps required for the shallow slats. This approach was not pursued in this design effort.

## 3.0 Conclusions and Recommendations

This design study has shown that there are solutions for the structural support and mechanization of slats that deploy to shallower angles and larger slots than is commonly done. Maximum slat deployment angles from 28° down to 10° were investigated, with slots ranging from 2.2% to 4% of local wing chord. Using Boeing 757 slat technology, the slat with 15° droop and a 3% slot seems to go together the easiest. Other design options are available to optimize slat support and actuation.

With the structural and mechanization feasibility for the shallow slat established, the next steps in the evaluation of this concept can be started. The most logical second step in this process would be a 2D CFD analysis of the concept to verify the aerodynamic data published by Ljungström. If this analysis shows positive results, a third step would be to select an existing wind tunnel model and perform a 3D CFD analysis on it. Step 4 would be a wind tunnel test to verify the results of the 3D analysis.

The benefits of the single slotted trailing edge flap over double slotted flaps are so large that a sure way to implement it should be devised. The shallow slat seems to be one of the most powerful approaches to making the single slotted flap possible, even on stretched growth airplanes. There should be a well organized effort to pursue this subject.

#### **4.0 Part II References**

1. Rudolph, Peter K. C.: "High-Lift Systems on Commercial Subsonic Airliners," NASA Contractor Report 4746, September 1996.
2. Ljungström, Björn L. G.: "Experimental High Lift Optimization of Multiple Element Airfoils," AGARD CP-143, April 1974.
3. Ljungström, Björn L. G.: "2-D Wind-Tunnel Experiments with Double and Triple Slotted Flaps," FFA Technical Note AU-993, 1973.

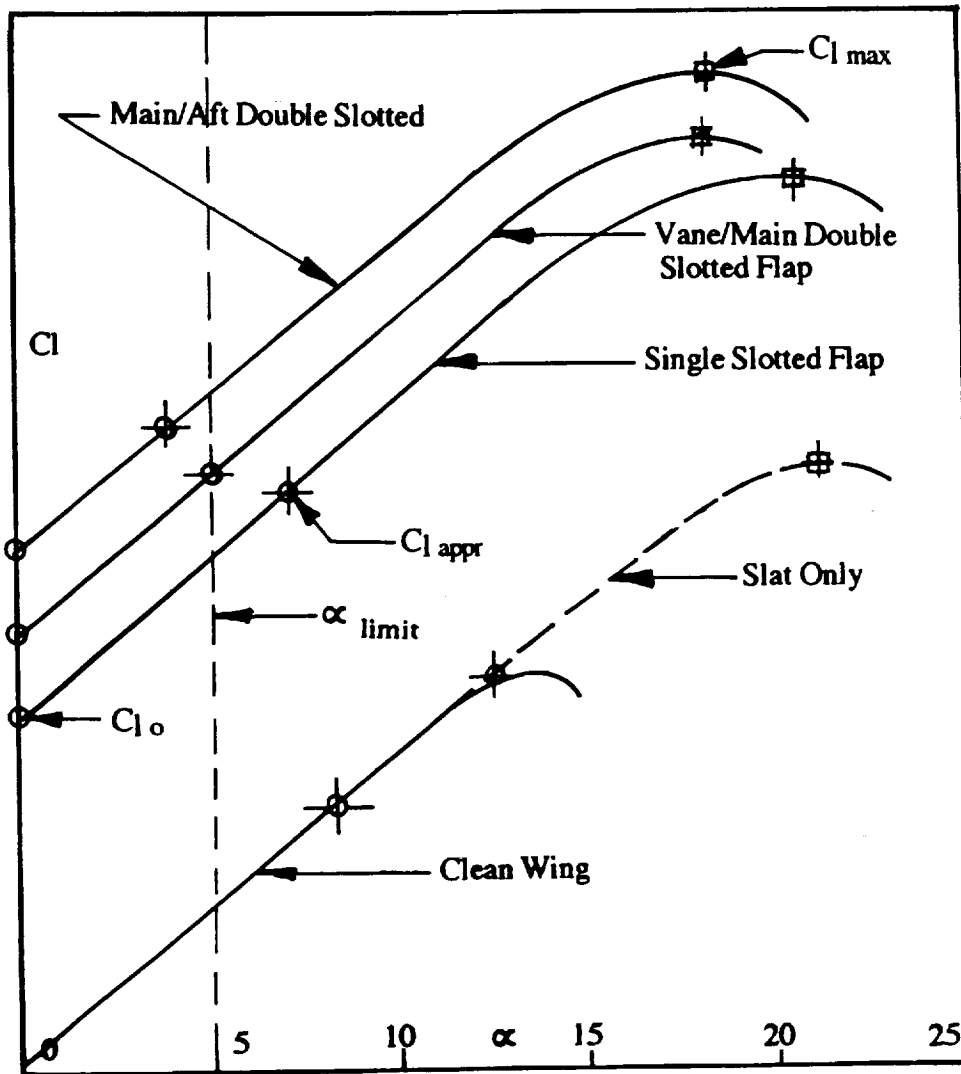

**Figure 1** Lift Curves in Landing Configuration

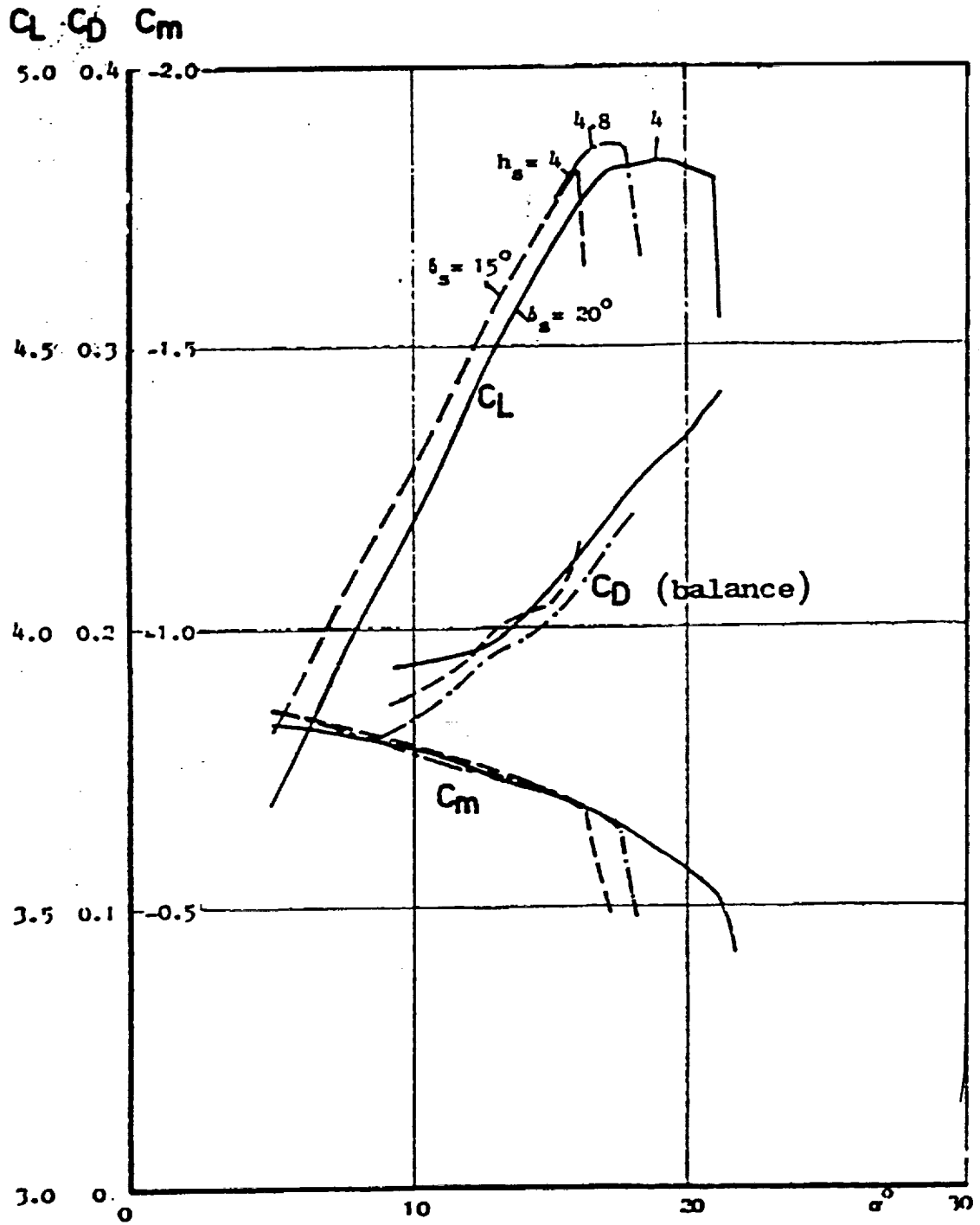
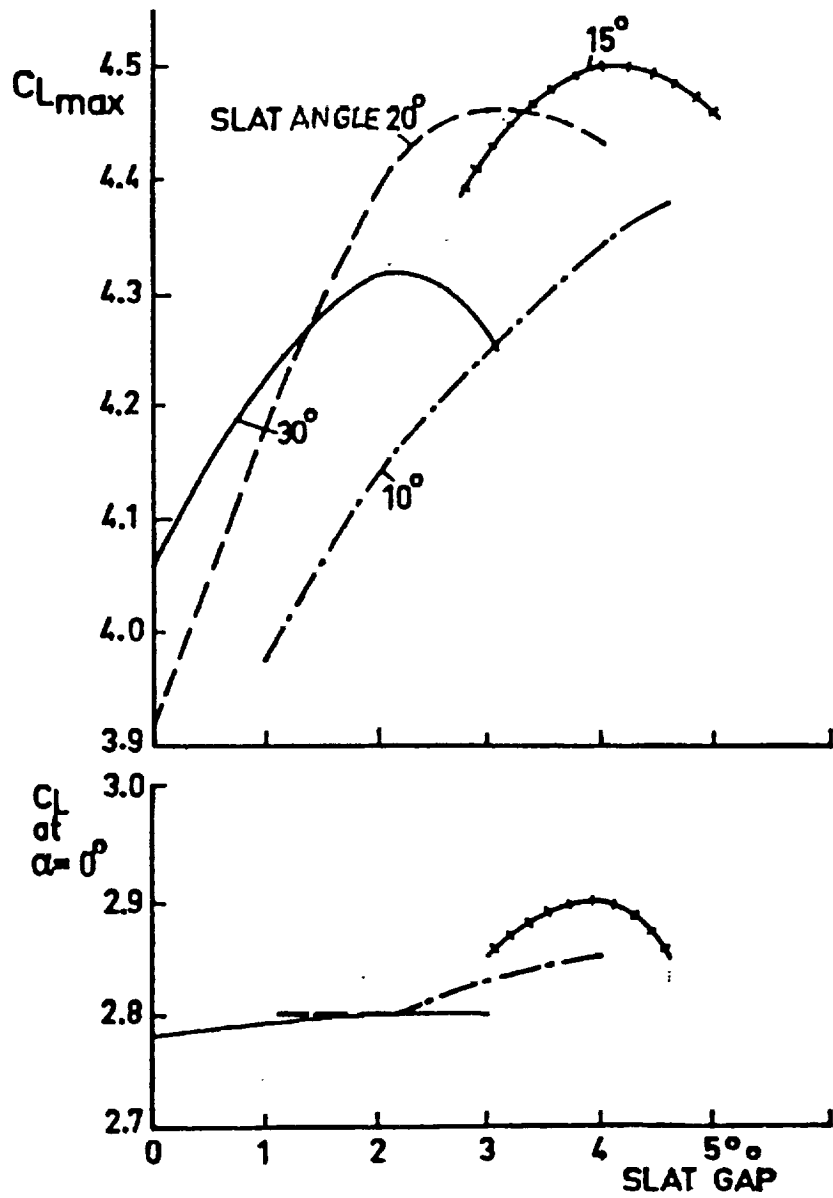

Figure 2 Slat Angle Variation (Ljungström)



**Figure 3** Slat Gap Effect for Different Slat Angles (Ljungström)





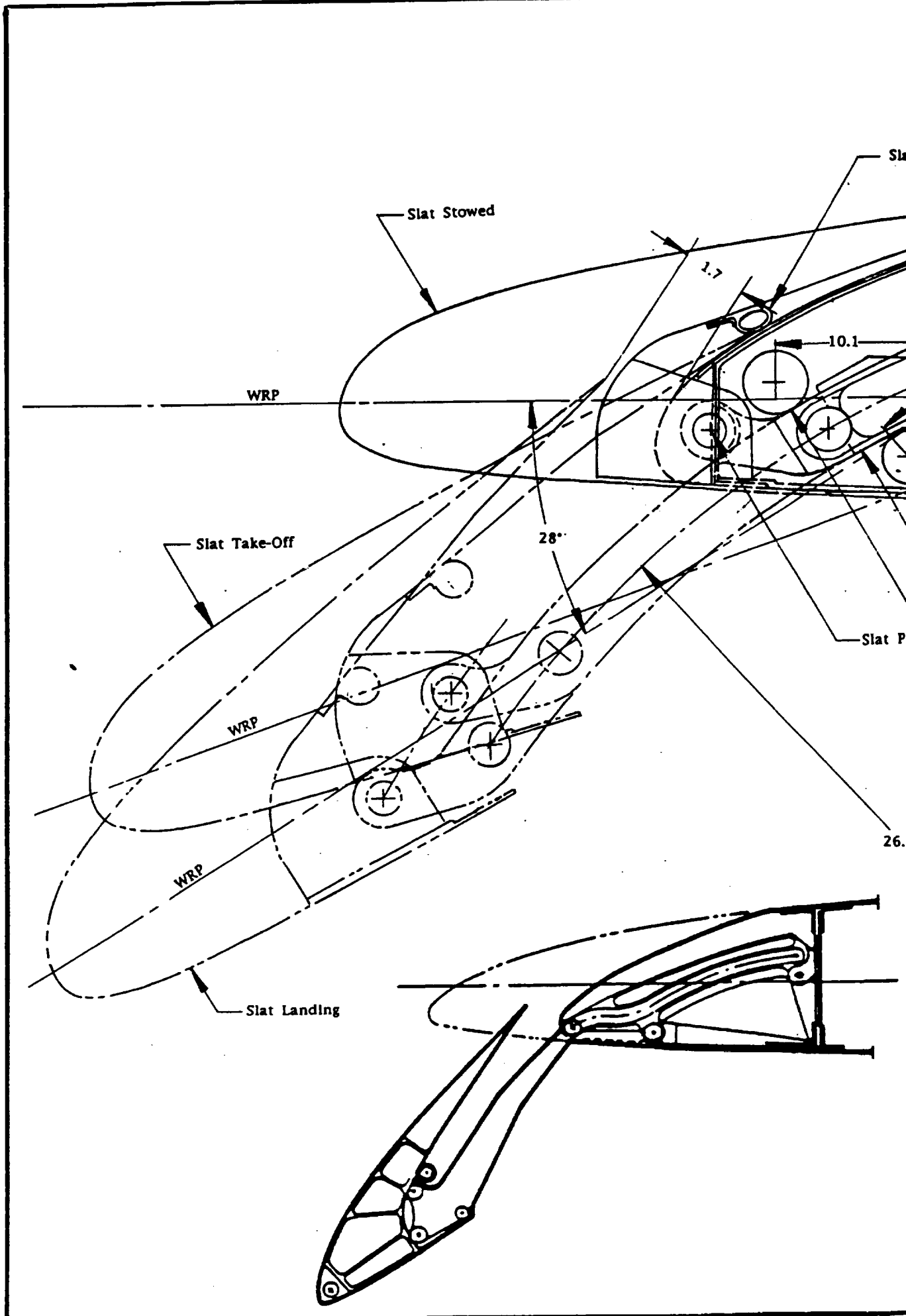
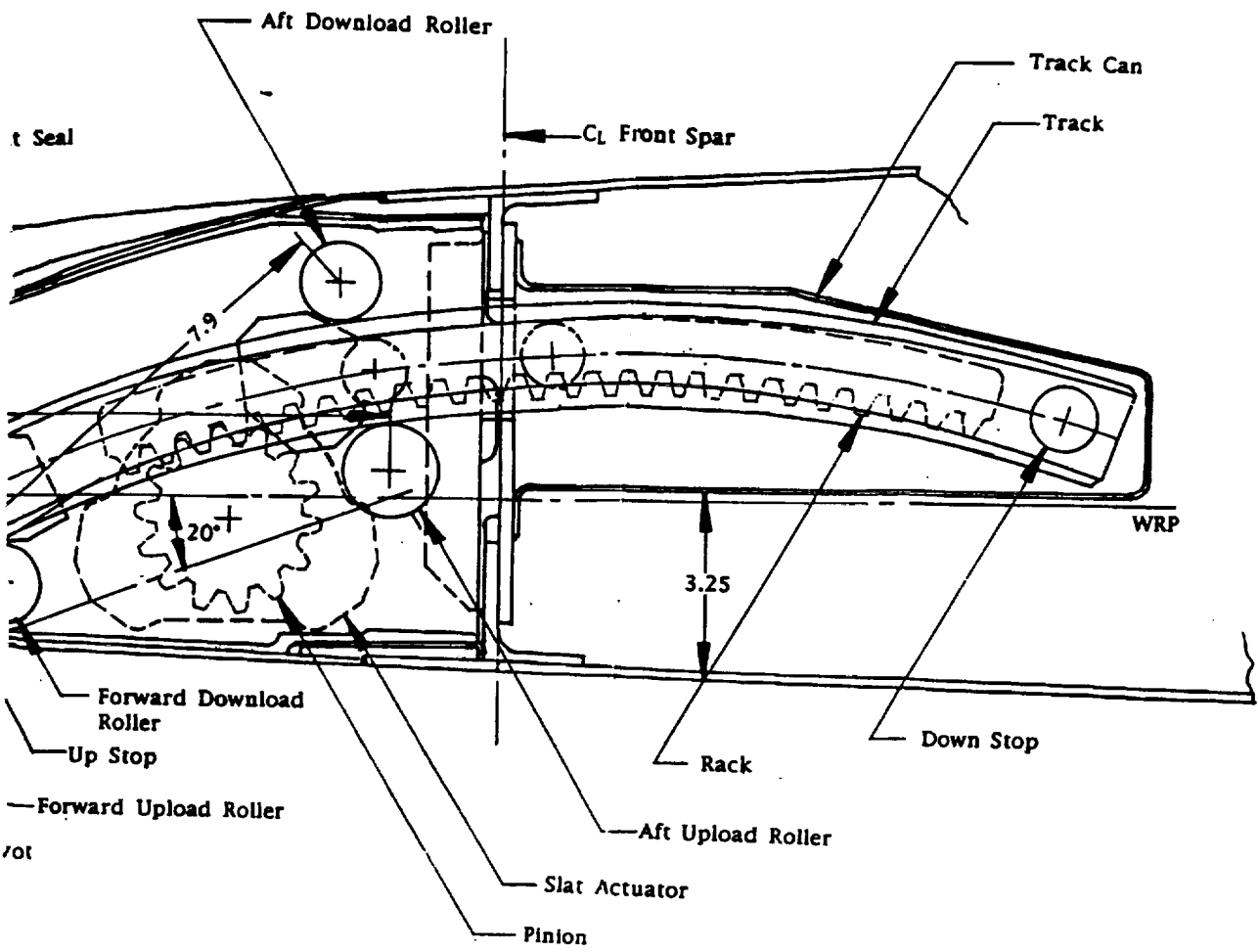



Figure 4

Boeing 757 Type Slat



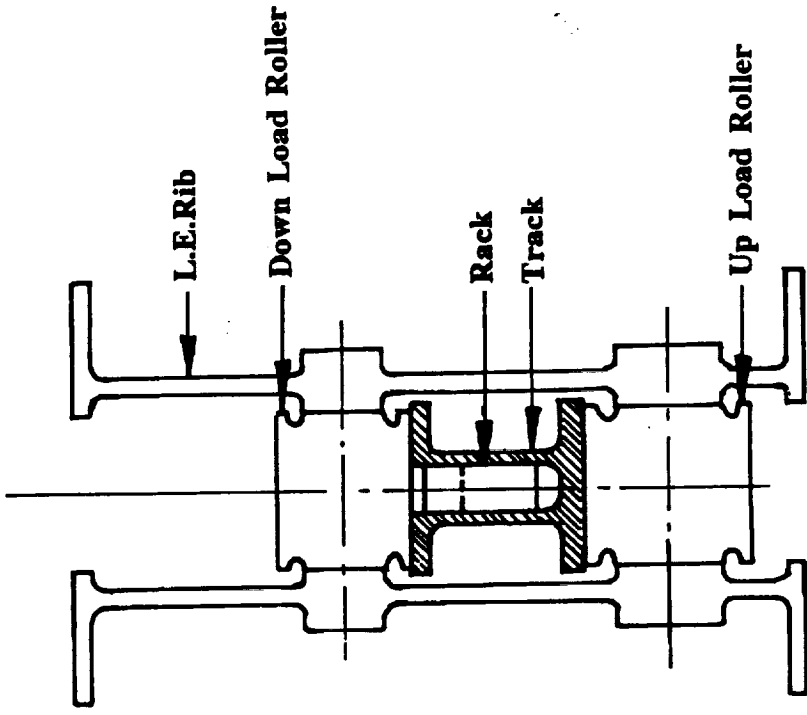

**Figure 4 Boeing 757 Type Slat with Rack and Pinion Drive**

	Shallow Slat Study 757 Type Slat with Slave Links (Slave Link Not Shown) Max. Slat Angle = 28°, 2.1% Gap, CWing = 80.0", Cslat = 19.75" (24.7%)	
	<i>Taylor K.C. Randolph</i>	01-17-97
<b>LO-PKCR-97-01</b>		
Scale 1/2		Sheet 1 of 4

with Rack and Pinion Drive

This page is intentionally blank.



**Roller/Track Arrangement for Shallow Slat  
(Actuator Above Track)**

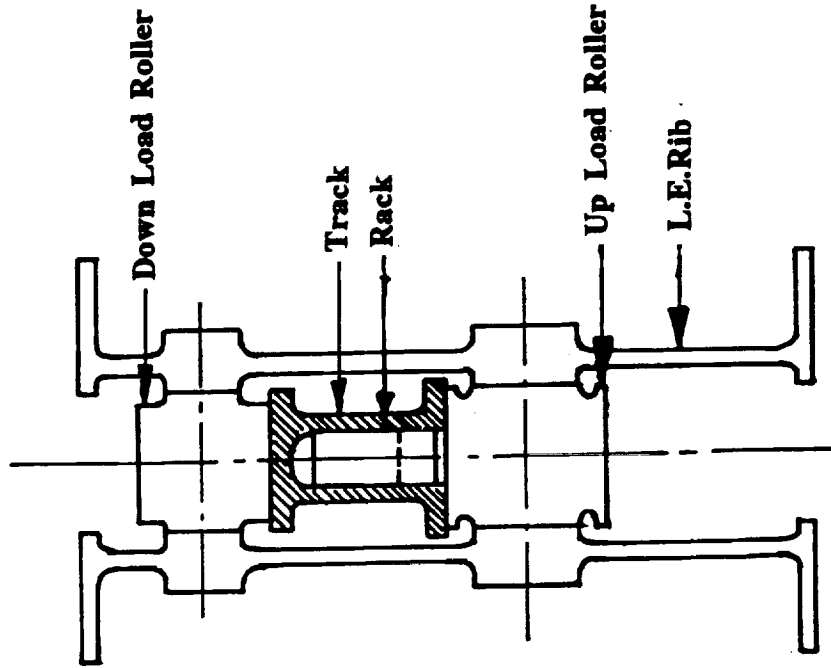

**Boeing 757 Roller/Track Arrangement  
(Actuator Below Track)**

**Figure 5 Roller/Track Arrangements**

This page is intentionally blank.

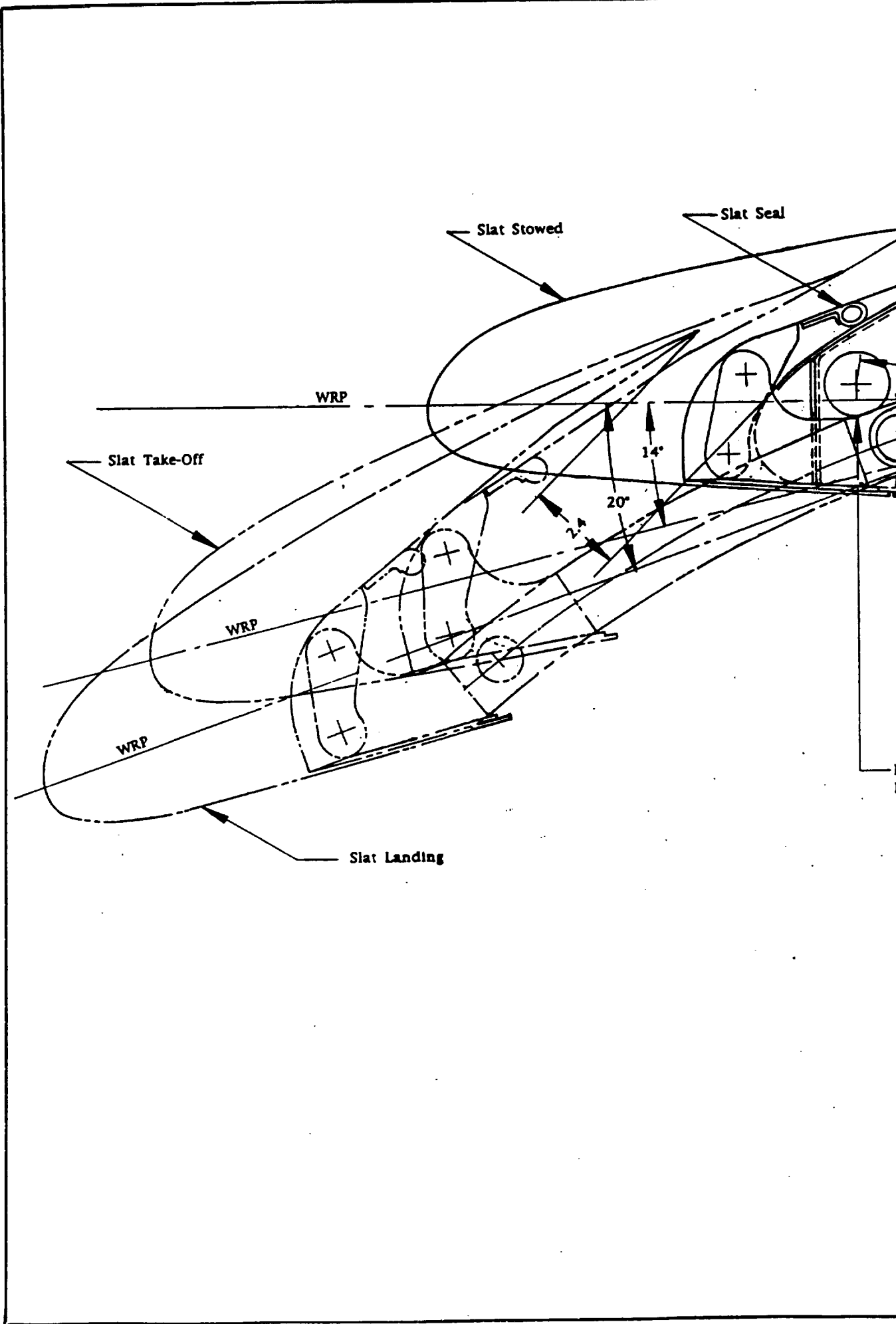
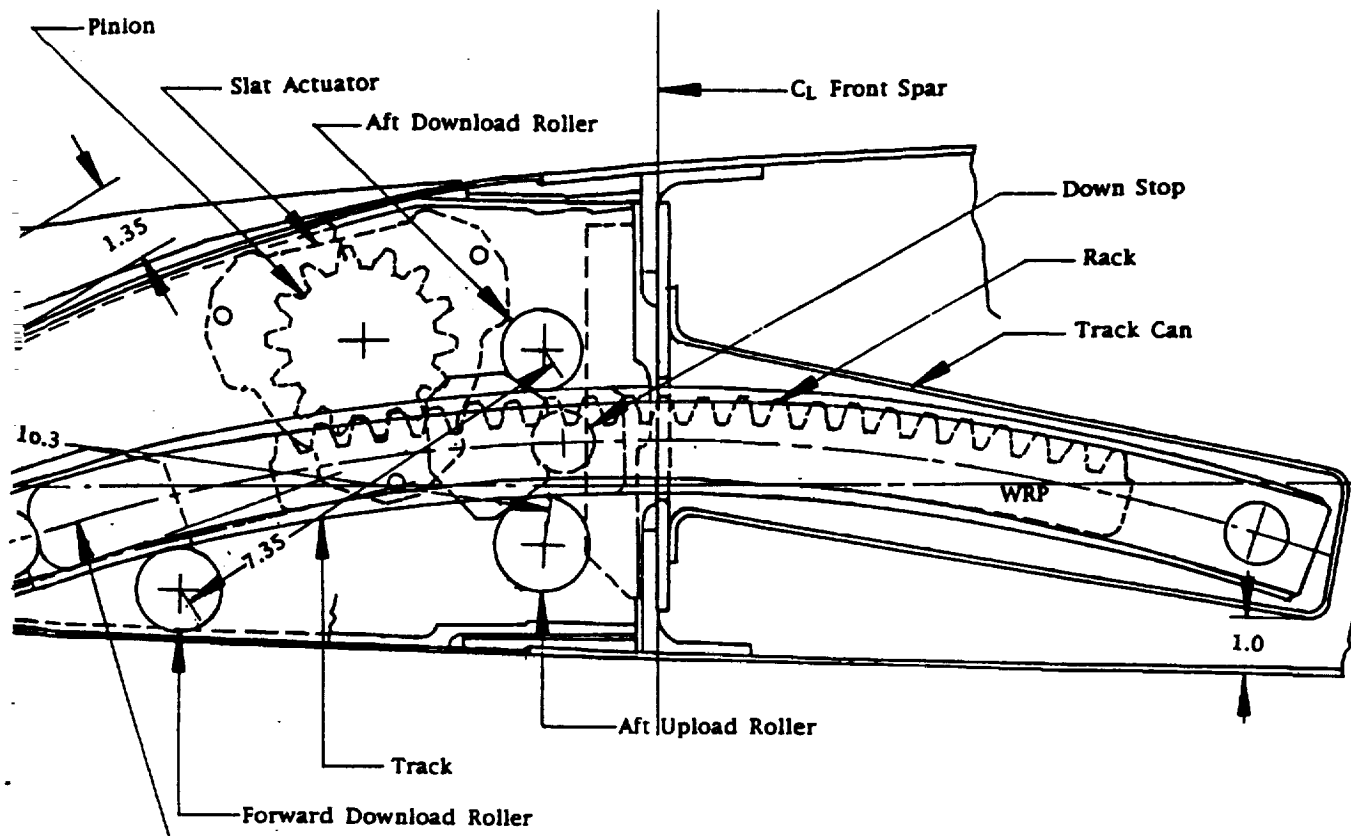

Figure 6

SH







33.85R  
 — Up Stop  
 Forward Upload Roller

	<b>Shallow Slat Study</b> (No Slave Links) Max. Slat Angle = 20°, 3% Gap, C <sub>wing</sub> = 80.0", C <sub>slat</sub> = 19.75" (24.7%)	
	<i>Peter K.C. Resdolph</i>	01-03-97
<b>LO-PKCR-97-01</b>		
Scale 1/2		Sheet 2 of 4

allow Slat with 20° Slat Angle

**This page is intentionally blank.**

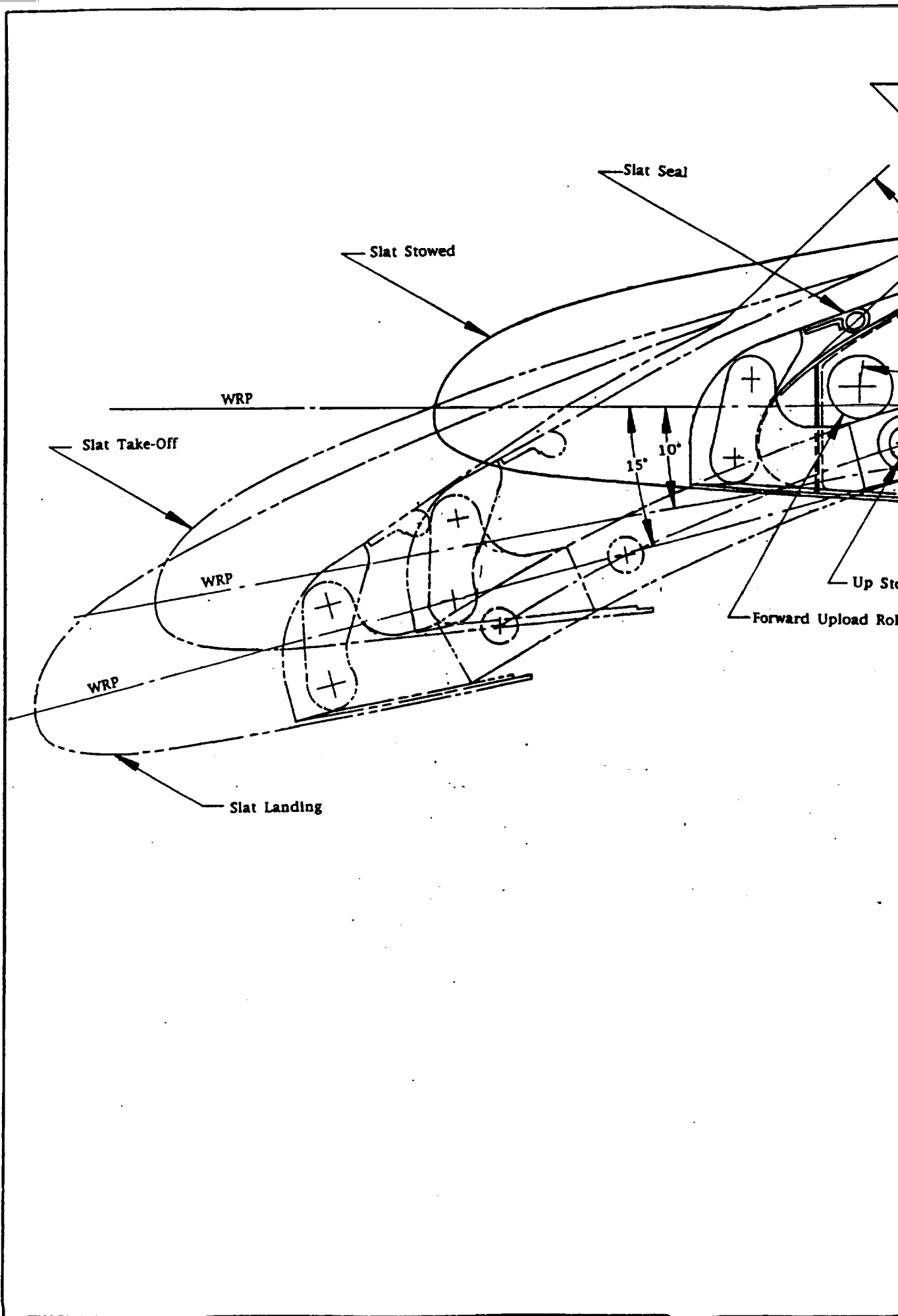
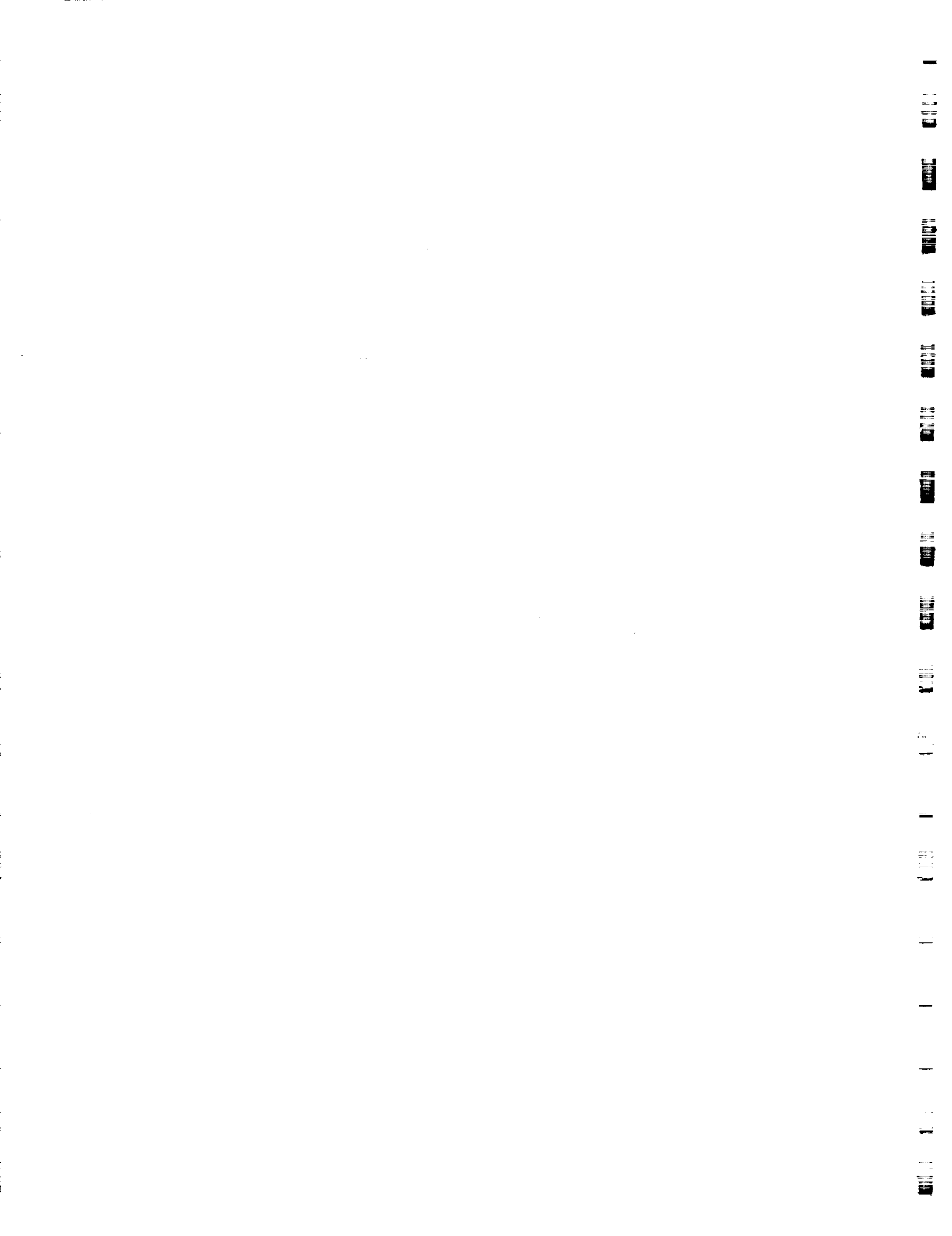
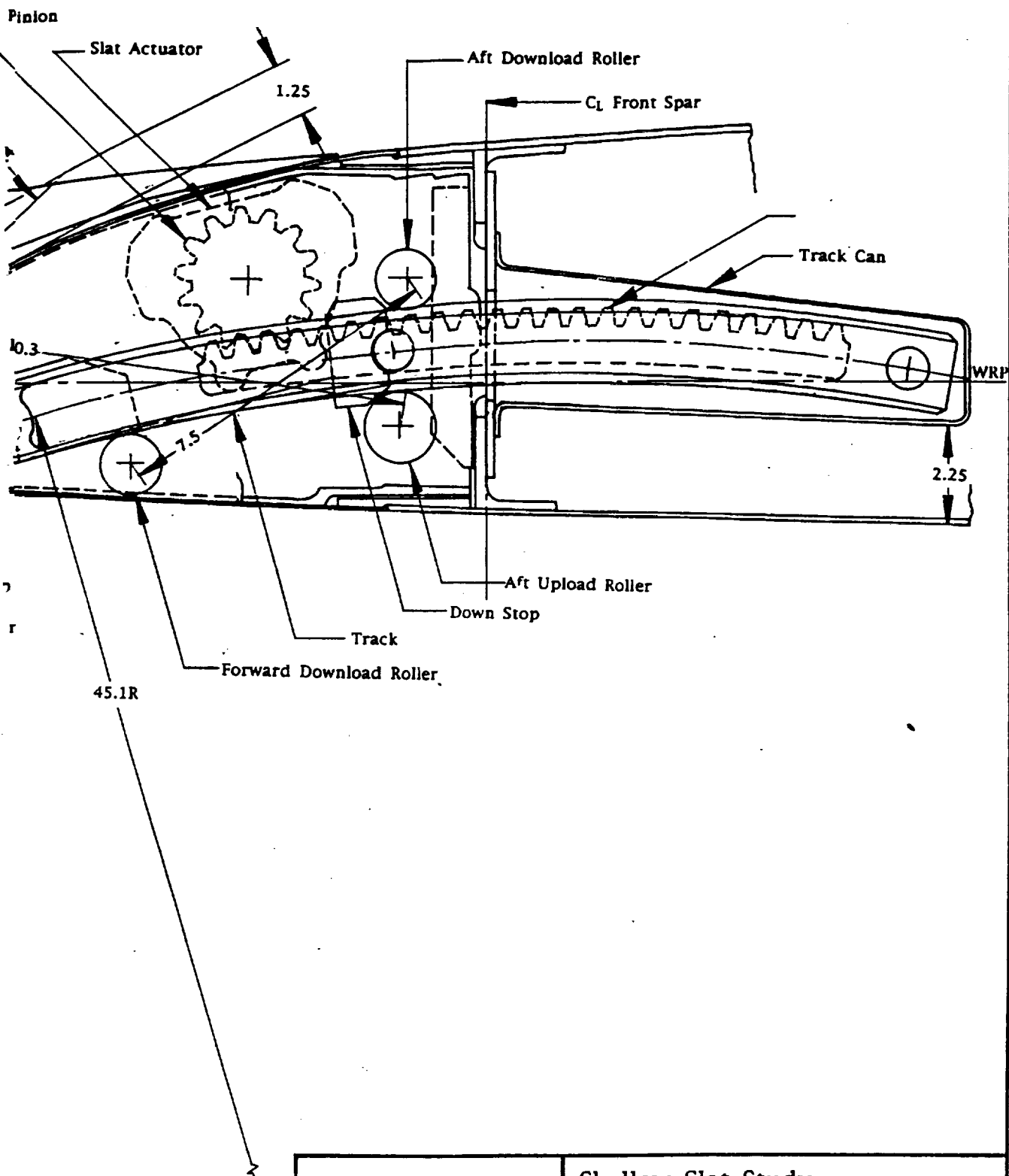



Figure 7





	<b>Shallow Slat Study</b> (No Slave Links) Max. Slat Angle = 15°, 3% Gap, C <sub>wing</sub> = 80.0" C <sub>slat</sub> = 19.75" (24.7%)	
	<i>Peter K.C. Rudolph</i>	01-09-97
<b>LO-PKCR-97-01</b>		
Scale 1/2		Sheet 3 of 4

**Shallow Slat with 15° Slat Angle**

**This page is intentionally blank.**

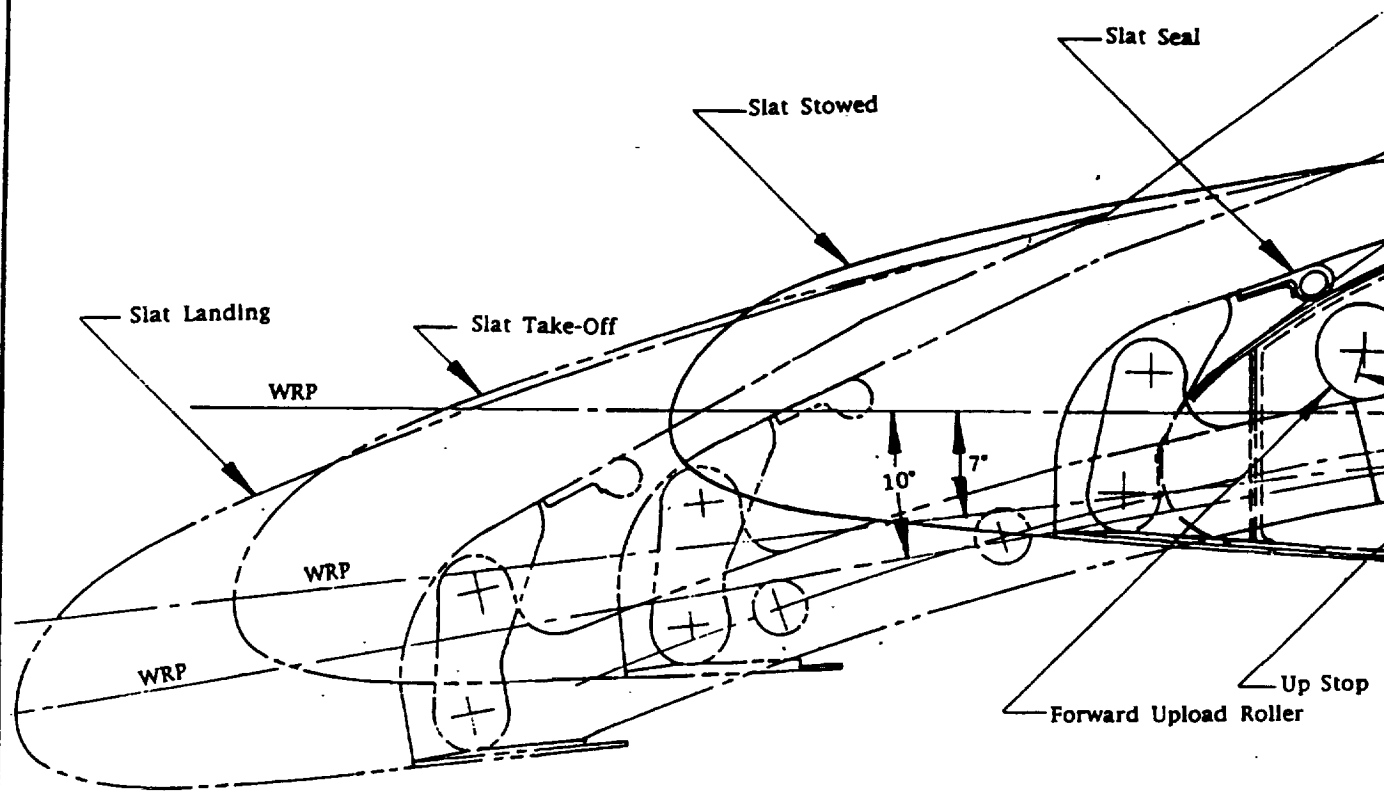
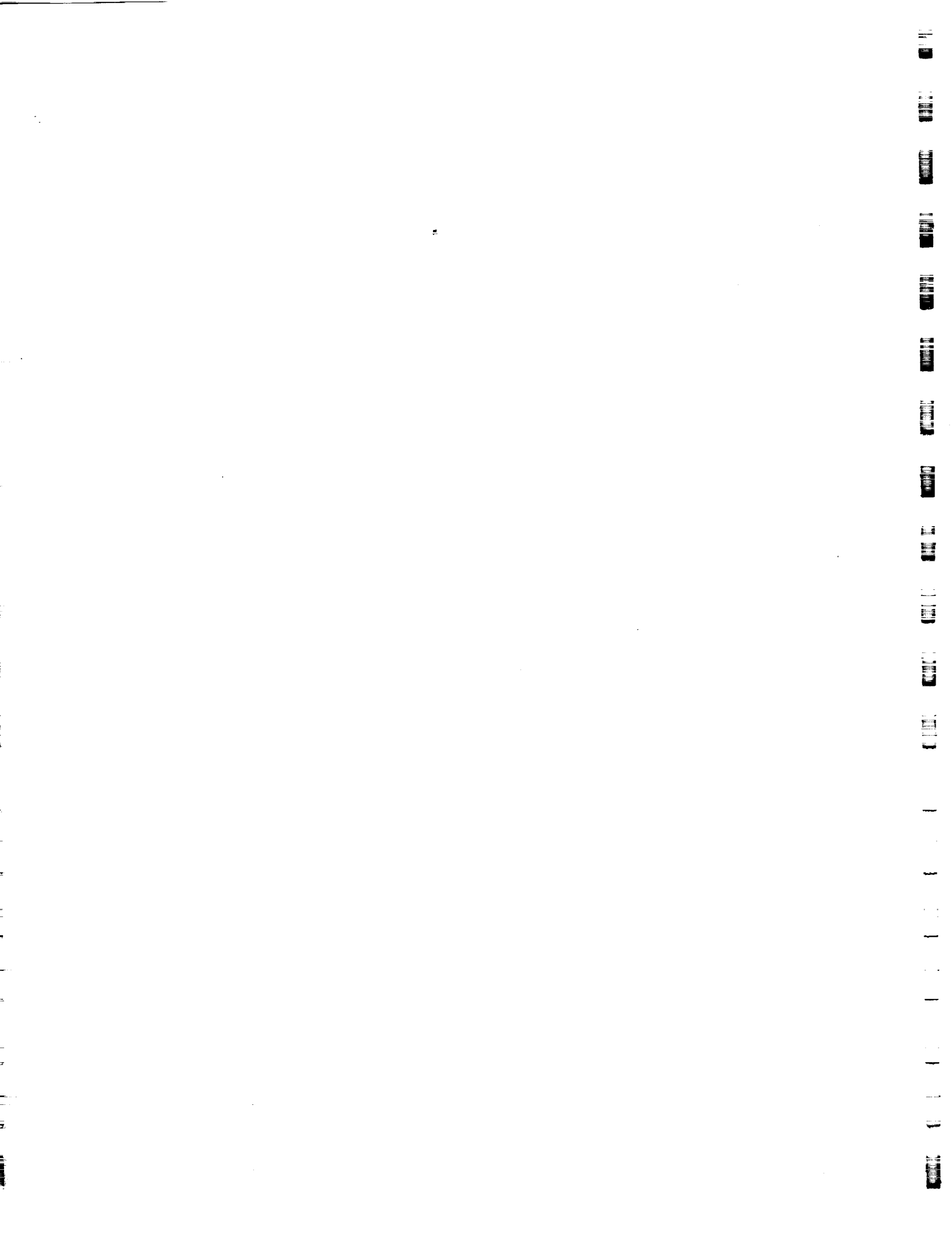
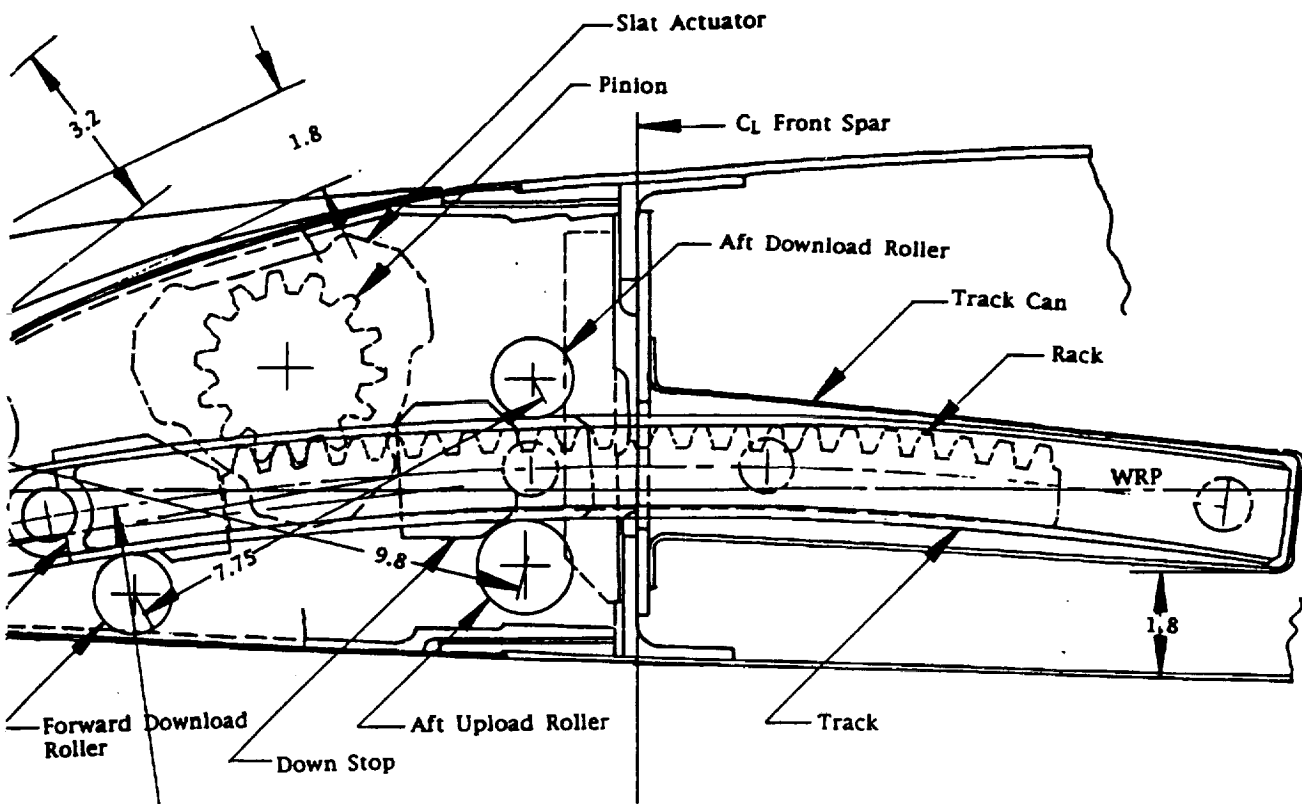



Figure 8

S







	<b>Shallow Slat Study</b> (No Slave Links) Max. Slat Angle = 10°, 4% Gap, C <sub>wing</sub> = 80.0" C <sub>slat</sub> = 19.75" (24.7%)	
	<i>Peter K.C. Randolph</i>	01-17-97
<b>LO-PKCR-97-01</b>		
Scale 1/2		Sheet 4 of 4

Shallow Slat with 10° Slat Angle

**This page is intentionally blank.**

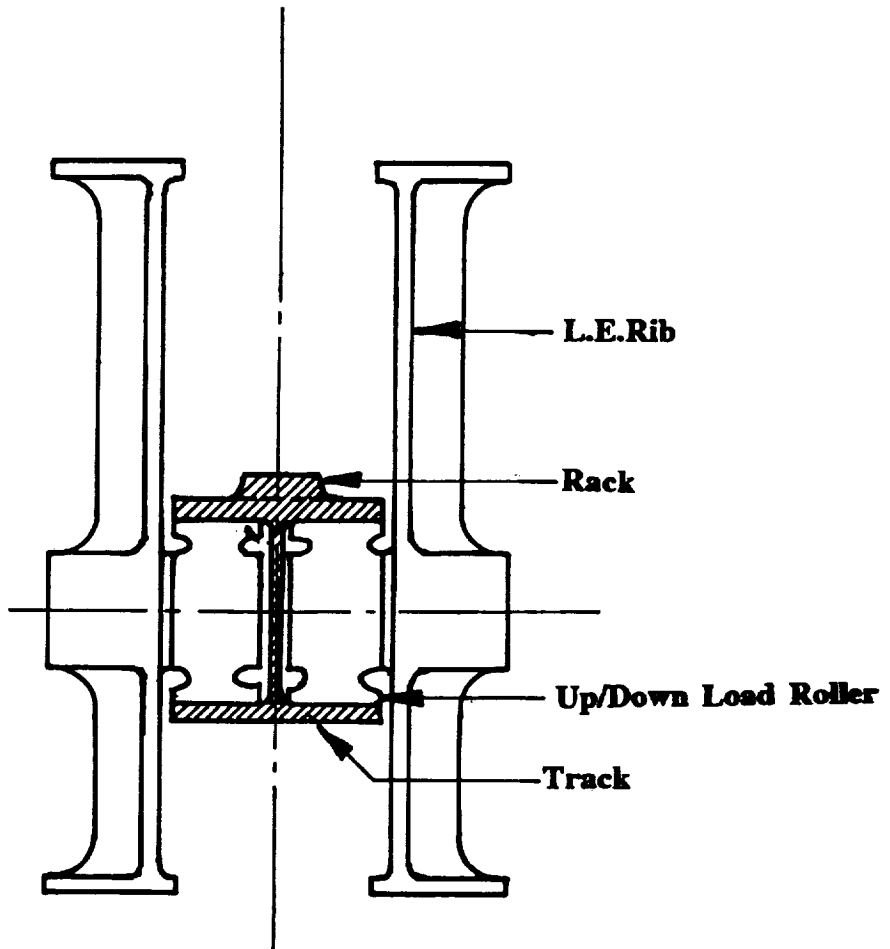

**Figure 9 Up/Down Load Rollers Inside Track**

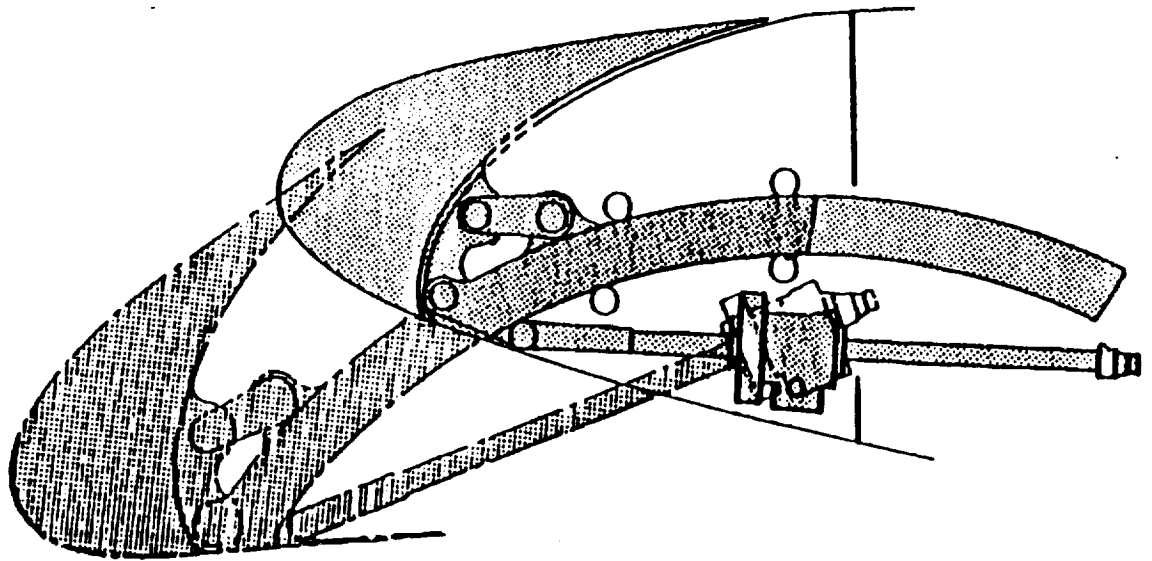

**A300/310 Slat Actuation  
(Screw Jack)**

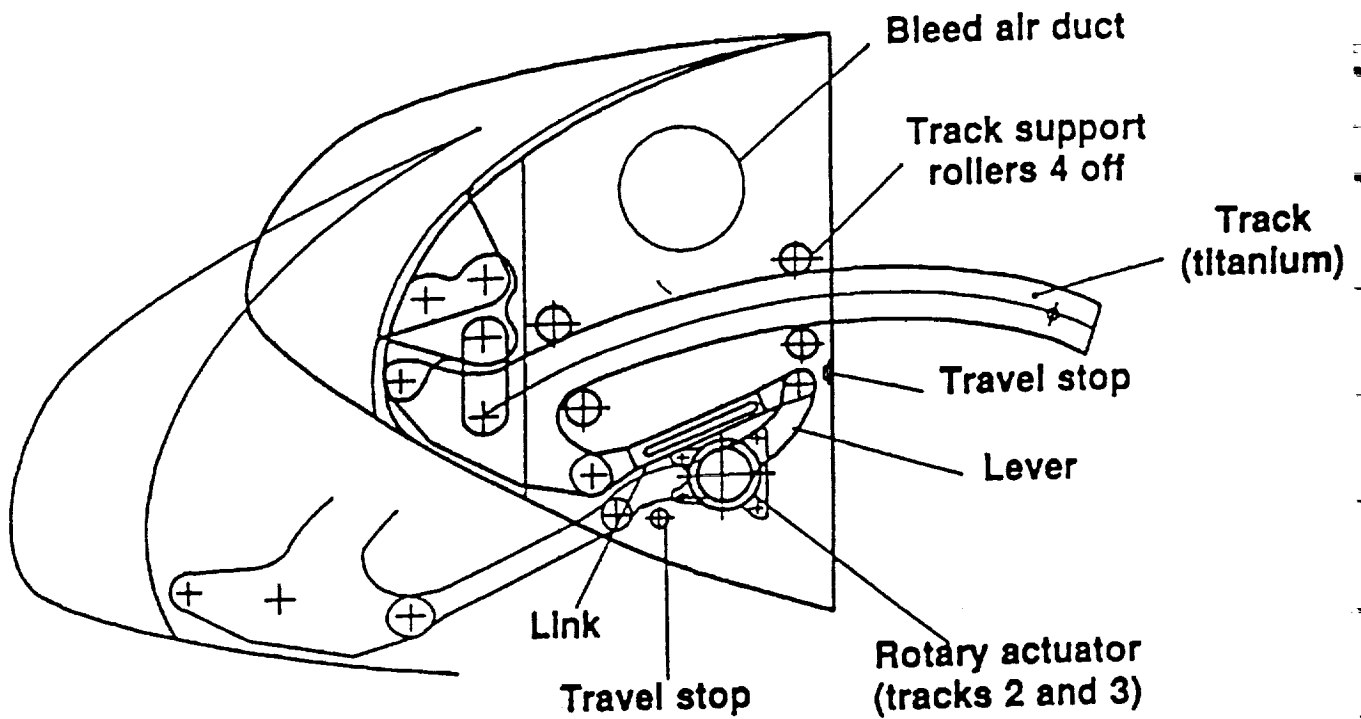

**A330/340 Inboard Slat Actuation  
(Rotary Actuator with Drive Link)**

**Figure 10**      **Alternate Actuation Methods for a Shallow Slat**

**This page is intentionally blank.**

# REPORT DOCUMENTATION PAGE

Form Approved  
OMB No. 0704-0188

Public reporting burden for this collection of information is estimated to average 1 hour per response, including the time for reviewing instructions, searching existing data sources, gathering and maintaining the data needed, and completing and reviewing the collection of information. Send comments regarding this burden estimate or any other aspect of this collection of information, including suggestions for reducing this burden, to Washington Headquarters Services, Directorate for Information Operations and Reports, 1215 Jefferson Davis Highway, Suite 1204, Arlington, VA 22202-4302, and to the Office of Management and Budget, Paperwork Reduction Project (0704-0188), Washington, DC 20503.

1. AGENCY USE ONLY (Leave blank)		2. REPORT DATE February 1998	3. REPORT TYPE AND DATES COVERED Contractor Report	
4. TITLE AND SUBTITLE Mechanical Design of High Lift Systems for High Aspect Ratio Swept Wings			5. FUNDING NUMBERS  A49736D(SLS)	
6. AUTHOR(S) Peter K. C. Rudolph				
7. PERFORMING ORGANIZATION NAME(S) AND ADDRESS(ES) PKCR, Inc. 13683 18th Ave. SW Seattle, WA 98166			8. PERFORMING ORGANIZATION REPORT NUMBER  A-989497	
9. SPONSORING/MONITORING AGENCY NAME(S) AND ADDRESS(ES) National Aeronautics and Space Administration Washington, DC 20546-0001			10. SPONSORING/MONITORING AGENCY REPORT NUMBER  NASA CR-196709	
11. SUPPLEMENTARY NOTES Point of Contact: Mark Waters, Ames Research Center, MS 237-11, Moffett Field, CA 94035-1000 (650) 604-3154				
12a. DISTRIBUTION/AVAILABILITY STATEMENT Unclassified-Unlimited Subject Category - 05  Available from the NASA Center for AeroSpace Information, 800 Elkridge Landing Road, Linthicum Heights, MD 21090; (301) 621-0390.			12b. DISTRIBUTION CODE	
13. ABSTRACT (Maximum 200 words) <p>The NASA Ames Research Center is working to develop a methodology for the optimization and design of the high lift system for future subsonic airliners with the involvement of two partners. Aerodynamic analysis methods for two dimensional and three dimensional wing performance with flaps and slats deployed are being developed through a grant with the aeronautical department of the University of California Davis, and a flap and slat mechanism design procedure is being developed through a contract with PKCR, Inc., of Seattle, WA. This report documents the work that has been completed in the contract with PKCR on mechanism design. Flap mechanism designs have been completed for seven (7) different mechanisms with a total of twelve (12) different layouts all for a common single slotted flap configuration. The seven mechanisms are as follows: Simple Hinge, Upside Down/Upright Four Bar Linkage (two layouts), Upside Down Four Bar Linkages (three versions), Airbus A330/340 Link/Track Mechanism, Airbus A320 Link/Track Mechanism (two layouts), Boeing Link/Track Mechanism (two layouts), and Boeing 767 Hinged Beam Four Bar Linkage.</p> <p>In addition, a single layout has been made to investigate the growth potential from a single slotted flap to a vane/main double slotted flap using the Boeing Link/Track Mechanism. All layouts show Fowler motion and gap progression of the flap from stowed to a fully deployed position, and evaluations based on spanwise continuity, fairing size and number, complexity, reliability and maintainability and weight as well as Fowler motion and gap progression are presented.</p> <p>For slat design, the options have been limited to mechanisms for a shallow leading edge slat. Three (3) different layouts are presented for maximum slat angles of 20°, 15° and 10° all mechanized with a rack and pinion drive similar to that on the Boeing 757 airplane. Based on the work of Ljungström in Sweden, this type of slat design appears to shift the lift curve so that higher lift is achieved with the deployed slat with no increase in angle of attack. The layouts demonstrate that these slat systems can be designed with no need for slave links, and an experimental test program is outlined to experimentally validate the lift characteristics of the shallow slat.</p>				
14. SUBJECT TERMS High lift, Design, Aeronautics			15. NUMBER OF PAGES 82	
			16. PRICE CODE A05	
17. SECURITY CLASSIFICATION OF REPORT Unclassified	18. SECURITY CLASSIFICATION OF THIS PAGE Unclassified	19. SECURITY CLASSIFICATION OF ABSTRACT	20. LIMITATION OF ABSTRACT	