

# FRACTURE MECHANICS OF THIN, CRACKED PLATES UNDER TENSION, BENDING AND OUT-OF-PLANE SHEAR LOADING

Alan T. Zehnder, C.-Y. Hui, Yogesh Potdar  
Department of Theoretical and Applied Mechanics  
Cornell University, Ithaca NY 14853  
(607)255-9181, (607)255-2011 (fax), atz2@cornell.edu

522-39  
037258

Alberto Zucchini  
ENEA  
40128 Bologna, Italy

## ABSTRACT

Cracks in the skin of aircraft fuselages or other shell structures can be subjected to very complex stress states, resulting in mixed-mode fracture conditions. For example, a crack running along a stringer in a pressurized fuselage will be subject to the usual in-plane tension stresses (Mode-I) along with out-of-plane tearing stresses (Mode-III like). Crack growth and initiation in this case is correlated not only with the tensile or Mode-I stress intensity factor,  $K_I$ , but depends on a combination of parameters and on the history of crack growth. The stresses at the tip of a crack in a plate or shell are typically described in terms of either the small deflection Kirchhoff plate theory. However, real applications involve large deflections. We show, using the von-Karman theory, that the crack tip stress field derived on the basis of the small deflection theory is still valid for large deflections. We then give examples demonstrating the exact calculation of energy release rates and stress intensity factors for cracked plates loaded to large deflections. The crack tip fields calculated using the plate theories are an approximation to the actual three dimensional fields. Using three dimensional finite element analyses we have explored the relationship between the three dimensional elasticity theory and two dimensional plate theory results. The results show that for out-of-plane shear loading the three dimensional and Kirchhoff theory results coincide at distance greater than  $h/2$  from the crack tip, where  $h/2$  is the plate thickness. Inside this region, the distribution of stresses through the thickness can be very different from the plate theory predictions. We have also explored how the energy release rate varies as a function of crack length to plate thickness using the different theories. This is important in the implementation of fracture prediction methods using finite element analysis. Our experiments show that under certain conditions, during fatigue crack growth, the presence on out-of-plane shear loads induces a great deal of contact and friction on the crack surfaces, dramatically reducing crack growth rate. A series of experiments and a proposed computational approach for accounting for the friction is discussed.

## 1. INTRODUCTION

The motivation for this work stems directly from concerns regarding fracture along a lap joint in a pressurized aircraft fuselage. As shown in Figure 1, in this scenario the side of the crack near the

stringer is much stiffer than the other, which is only a single sheet thick. This less stiff side bulges out further than the stiff side, resulting in out-of-plane tearing stresses as the crack tip. At the outset of our research little was known about fracture and fatigue in sheets under such loadings. Thus, to be able to answer practical questions regarding the integrity of pressurized shell structures, we have, over the past six years studied the fracture mechanics of sheets under tension and out-of-plane shear loading.

As defined in Figure 2, for general loadings of thin, cracked plates under membrane and out-of-plane loads, two fracture modes with corresponding stress intensity factors  $K_I, K_{II}$  can be identified with the membrane loads, and two fracture modes with stress intensity factors  $k_1, k_2$  can be identified with the out-of-plane loads. Analyses such as the results in Figure 1 show that the two important fracture modes for the lap joint problem are the membrane  $K_I$  and the out-of-plane  $k_2$ . Thus, the discussion in this paper will emphasize problems combining  $K_I$  and  $k_2$  loadings. The crack tip stress fields and energy release will be discussed first, followed by a discussion of effects of large deflections, and finally fatigue crack growth. Details of some of this work appear in earlier publications, [1-8], while other sections, namely the discussion of the three dimensional crack tip fields is new.

## 2. STRESS FIELD AND ENERGY RELEASE RATES

Crack growth is determined by the stress and strain fields in the immediate vicinity of the crack tip. Thus to understand the behavior of cracked plates and to correlate experimental data, the crack tip fields must be understood and described. The crack tip fields are inherently three dimensional, and in principal can be determined numerically for each particular situation. Such an approach, however is not only overwhelming from the engineering point of view, but gives little insight into the general nature of the crack tip fields. Our approach is to construct analytical models of the crack tip stress state using Kirchhoff plate theory superimposed with plane stress. In this construction the stresses on a plane ahead of the crack, in the coordinate system of Figure 3, are

$$\begin{aligned}\sigma_{yy} &= \frac{K_I}{\sqrt{2\pi r}} + \frac{k_1}{\sqrt{2r}} \frac{2z}{h}, \\ \sigma_{xy} &= \frac{K_{II}}{\sqrt{2\pi r}} + \frac{k_2}{\sqrt{2r}} \frac{2z}{h} \left( \frac{1+\nu}{3+\nu} \right), \\ \sigma_{23} &= \frac{-k_2 h}{2(2r)^{3/2} (3+\nu)} \left[ 1 - \left( \frac{2z}{h} \right)^2 \right],\end{aligned}$$

where  $\nu$  is the Poisson's ratio,  $h$  is the plate thickness, and the stress intensity factors,  $K_I, K_{II}, k_1, k_2$  are defined in Figure 3.

The crack tip energy release rate is related to the stress intensity factors by [5,7]

$$G = \frac{K_I^2 + K_{II}^2}{E} + \frac{k_1^2 + k_2^2}{3E} \pi \left( \frac{1+\nu}{3+\nu} \right),$$

where  $E$  is the Young's modulus.

The Kirchhoff plate theory is restricted to small deflections, however in many practical problems involving fracture of thin plate the deflection will not be small. This leads to the question: Do the Kirchhoff theory fields still describe the crack tip stresses when the deflection is large? As proven in ref.[1] the answer is yes. Large deflections, however, couple the in-plane and out-of-plane fracture modes, and are non-linear functions of the applied loads. Several examples are given in ref.[1].

In reality the crack tip fields are three dimensional varying through the thickness of the plate with distributions that may differ from those in the above equations. For example, Figure 4 shows the out-of-plane shear stress for a thin cracked plate under uniform shear. Away from the crack tip the distribution is approximately parabolic as predicted by plate theory, but very close to the crack tip,  $2r/h < 0.3$  the stress is nearly constant through the thickness, going to zero in a boundary layer at the free surface. Further investigation of the relationship between the three dimensional fields and the plate theory fields is underway, using the finite element method.

### 3. FATIGUE CRACK GROWTH UNDER $K_1, k_2$ LOADING

To simulate fatigue crack growth of a lap joint crack experiments were performed using a double edge cracked sheet of 0.090" thick 2024-T3 aluminum alloy loaded in in-phase cyclic tension and torsion[6,8]. The test specimen is shown in Figure 5. Some of the results of these experiments are given in Figure 6 which plots fatigue crack growth rate versus the cyclic mode-I stress intensity factor only. Generally the crack initially grows faster than the rate for pure mode-I loading. However as the fatigue crack length increases the crack growth slows down, even stops for extended periods before jumping forward. The reason for this is the great amount of contact and friction that occurs behind the crack as the crack surfaces try to slide past one another to accommodate the out-of-plane shear loading. A second set of experiments were performed in which crack face contact was artificially eliminated. These experiments show that the rate of fatigue crack growth rate in the absence of contact is well above the pure mode-I rate.

These results led us to ask: Is there a way to quantify the effect of crack face contact in such situations? We take the point of view that the actual stress intensity factor seen at the crack tip is the  $K$  due to external loading minus the  $K$  due to crack face contact. To estimate the  $K$  due to contact a set of experiments keeping the  $K$  due to external loading was performed. In these constant nominal  $\Delta K$  experiments, as shown in Figure 7, the rate of crack growth is initially greater than the pure mode-I rate then decreases steadily with increasing crack length. The experiments provide a data pool to aid in the construction of a modeling approach for crack face contact, friction and their effect on crack growth. We have proposed an approach for the development and implementation of such models. In the proposed study the wear and consequent evolution of friction of the crack faces will be measured directly with the results used to determine parameters of a state variable model of friction. This model would then be implemented in a finite element simulation of crack growth. If this approach is successful it will point the way to performing accurate engineering predictions of fatigue crack growth in thin sheets under tension and out-of-plane shear loading.

### ACKNOWLEDGMENTS

This work was supported by NASA Langley Research Center, through grant NAG-1-1311.

## REFERENCES

1. C.-Y. Hui, Alan T. Zehnder, and Yogesh Potdar, "Williams meets von Karman: Mode Coupling and Non-Linearity in the Fracture of Thin Plates," to appear in **International Journal of Fracture**, (1998).
2. M. Viz , D. Potyondy, A. Zehnder, C. Rankin, and E. Riks, "Computation of Membrane and Bending Stress Intensity Factors for Thin, Cracked Plates," **International Journal of Fracture**, Vol. 72, pp. 21-38 (1995).
3. Mark J. Viz, Alan T. Zehnder, and John-David Bamford, "Fatigue Fracture of Thin Plates Under Tensile and Transverse Shear Stresses," in **Fracture Mechanics: 26th Volume, ASTM STP 1256**, Reuter et al. (eds.) American Society for Testing and Materials, Philadelphia, PA, pp. 631-651, (1995).
4. Alan T. Zehnder, and Chung-Yuen Hui, "Stress Intensity Factors for Plate Bending and Shearing Problems," **Journal of Applied Mechanics**, Vol. 61, pp. 719-722, (1994).
5. C.Y. Hui and Alan.T. Zehnder, "A Theory for the Fracture of Thin Plates Subjected to Bending and Twisting Moments," **International Journal of Fracture**, Vol. 61, pp. 211-229, (1993).
6. Mark J. Viz, and Alan T. Zehnder, "Fatigue Crack Growth in 2024-T3 Aluminum Under Tensile and Transverse Shear Stresses", in **FAA/NASA International Symposium on Advanced Structural Integrity Methods for Airframe Durability and Damage Tolerance**, NASA CP-3274, C. Harris, (ed.) pp. 891-910 (1994).
7. Alan T. Zehnder, Mark J. Viz, and Anthony R. Ingraffea, "Fatigue Fracture in Thin Plates Subjected to Tensile and Shearing Loads: Crack Tip Fields, J Integral and Preliminary Experimental Results," Proceedings of the **VII International Congress on Experimental Mechanics**, pp. 44-50, Society for Experimental Mechanics, Bethel, CT, (1992).
8. Mark J. Viz, "Fatigue Fracture Under In-Plane Symmetric and Out-of-Plane Antisymmetric Mixed-Mode Deformations", Ph.D. Thesis, Cornell University, (1996).

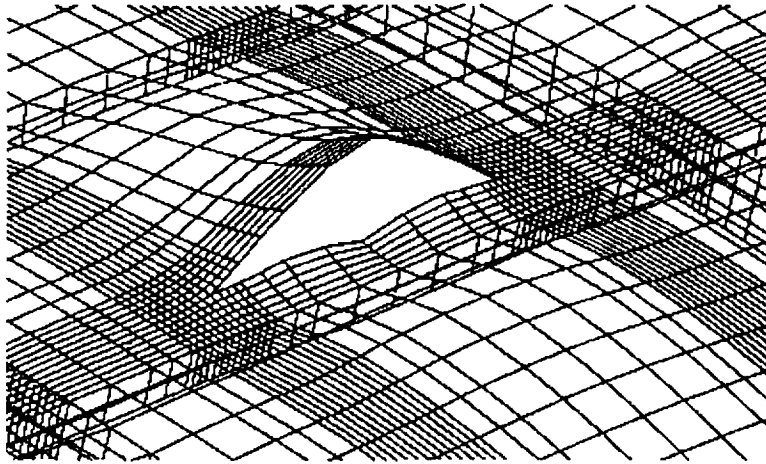

**Figure 1**, Deformed mesh from a finite element analysis of a one-bay fuselage section with a crack lying alongside a stringer. Bulging out of one side relative to the other is clearly seen. (from V.O. Britt, formerly of NASA Langley).

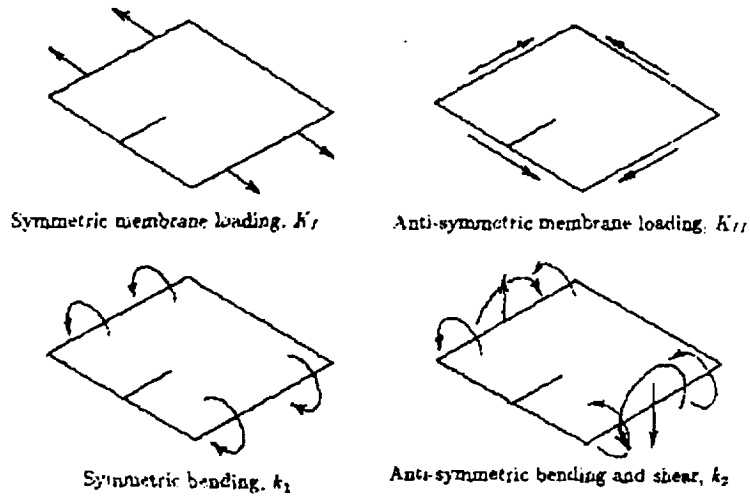

**Figure 2**, Membrane, bending and transverse shear fracture modes for a plate with a straight through crack. Stress intensity factors corresponding to each mode are shown.

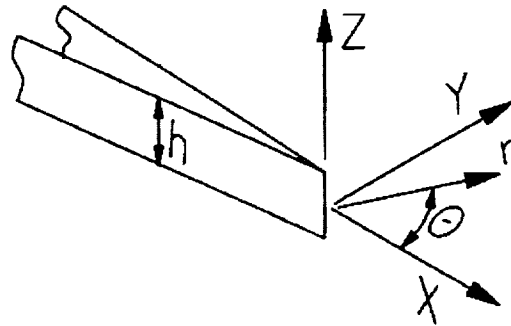

Figure 3, Crack tip coordinate system.

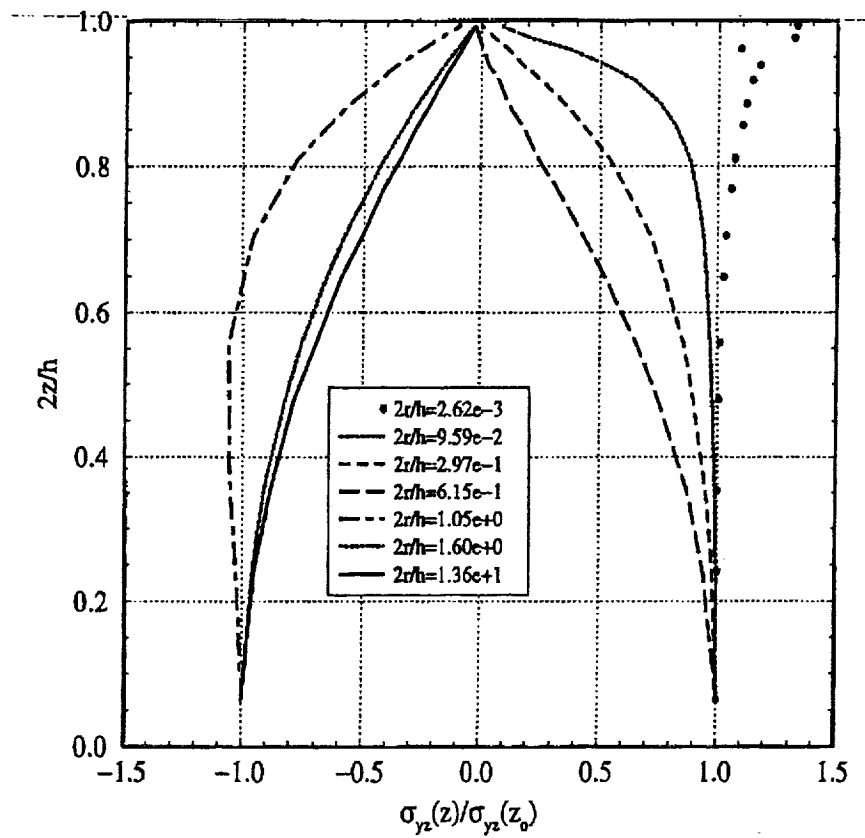

Figure 4, Thin cracked plate under uniform shear ( $h/a=0.02$ ). Distributions of the out-of-plane shear stress through the thickness from a three dimensional finite element analysis at different radial distances from the crack tip. ( $z_0=0.065 h/2$ )

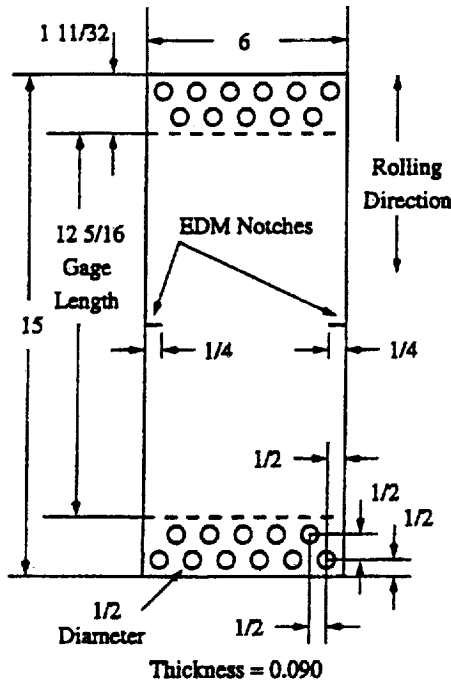

Figure 5, Double edge notched tension torsion fatigue crack growth test specimen.

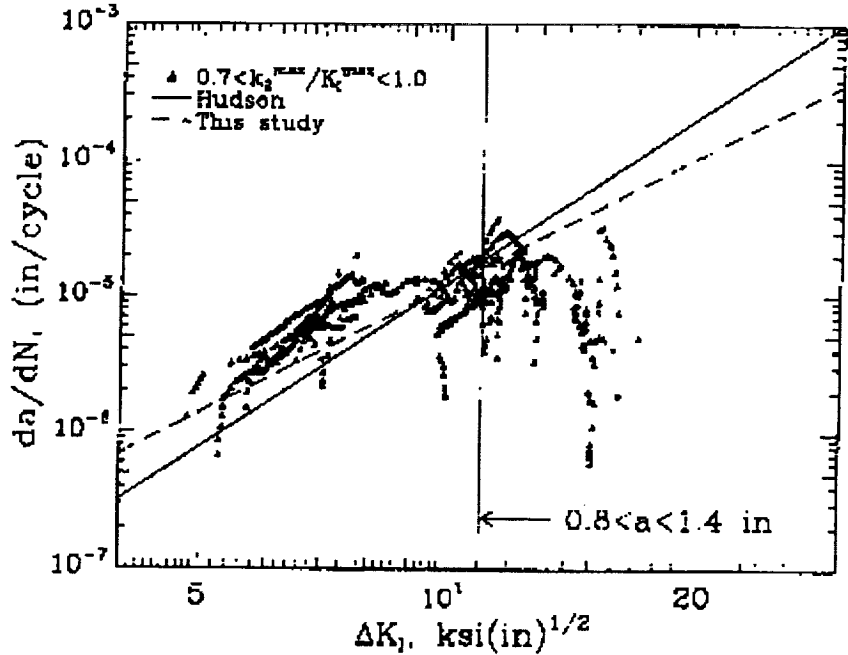

Figure 6, Mixed-mode fatigue crack growth rate results from relatively large values of  $\Delta k_2$ . The solid and dashed lines represent the crack growth rate for pure mode-I loading. The vertical line indicates the range of crack lengths present in this data when  $\Delta K_I = 11 ksi in^{1/2}$ .

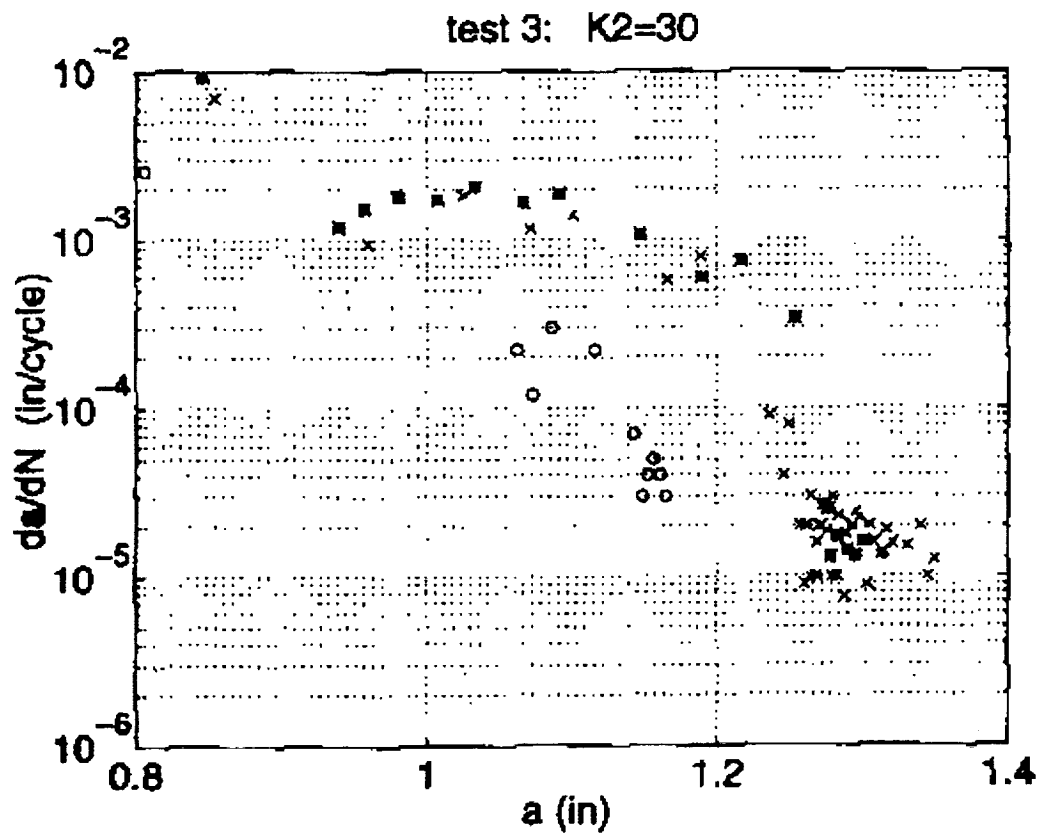

Figure 7, Mixed-mode fatigue crack growth rate vs. crack length from constant  $\Delta K_1$ ,  $\Delta k_2$  tests. Initial crack length is 0.8 inches.