

# A New Compendium of Unsteady Aerodynamic Test Cases for CFD: Summary of AVT WG-003 Activities

51-02  
381236

Luis P. Ruiz-Calavera, INTA, Spain (ruizel@inta.es)

Robert Bennett, NASA Langley Research Center, USA (r.m.bennett@larc.nasa.gov)

John H. Fox, Sverdrup Technology, Inc., USA (fox@hap.arnold.af.mil)

Robert W. Galbraith, Glasgow University, UK (r.a.m.galbraith@aero.gla.ac.uk)

Evert Geurts, NLR, The Netherlands (geurts@nlr.nl)

Michael J deC Henshaw, BAe, UK (Michael.Henshaw@bae.co.uk)

XingZhong Huang, IAR, Canada (xingzhong.huang@nrc.ca)

Ian W. Kaynes, DERA Farnborough, UK (iwkaynes@dra.hmg.gb)

Thomas Löser, DLR Braunschweig, Germany (Thomas.Looser@dlr.de)

Pierre Naudin, ONERA, France (naudin@onera.fr)

Masato Tamayama, NAL, Japan (masato@nal.go.jp)

## INTRODUCTION

With the continuous progress in hardware and numerical schemes, Computational Unsteady Aerodynamics (CUA), that is, the application of Computational Fluid Dynamics (CFD) to unsteady flowfields, is slowly finding its way as a useful and reliable tool (turbulence and transition modeling permitting) in the aircraft, helicopter, engine and missile design and development process. Before a specific code may be used with confidence it is essential to validate its capability to describe the physics of the flow correctly, or at least to the level of approximation required, for which purpose a comparison with accurate experimental data is needed. Unsteady wind tunnel testing is difficult and expensive; two factors which dramatically limit the number of organizations with the capability and/or resources to perform it. Thus, unsteady experimental data is scarce, often classified and scattered in diverse documents. Additionally, access to the reports does not necessarily assure access to the data itself. The collaborative effort described in this paper was conceived with the aim of collecting into a single easily accessible document as much quality data as possible.

The idea is not new. In the early 80's NATO's AGARD (Advisory Group for Aerospace Research & Development) Structures and Material Panel (SMP) produced AGARD Report No. 702 'Compendium of Unsteady Aerodynamic Measurements', which has found and continues to find extensive use within

the CUA community. In 1995 AGARD's Fluid Dynamics Panel (FDP) decided to update and expand the former database with new geometries and physical phenomena, and launched Working Group WG-22 on 'Validation Data for Computational Unsteady Aerodynamic Codes'. Shortly afterwards AGARD was reorganized as the RTO (Research and Technology Organization) and the WG was renamed as AVT (Applied Vehicle Technology) WG-003. Contributions were received from AEDC, BAe, DLR, DERA, Glasgow University, IAR, NAL, NASA, NLR, and ONERA. The final publication with the results of the exercise is expected in the second part of 1999.

The aim of the present paper is to announce and present the new database to the Aeroelasticity community. It is also intended to identify, together with one of the groups of end users it targets, deficiencies in the compendium that should be addressed by means of new wind tunnel tests or by obtaining access to additionally existing data.

## **REQUIREMENTS FOR EXPERIMENTS**

The type of experiment included in the database falls under the general category of validation experiments, that is, those made on geometrically simple "generic shapes" designed to provide sufficiently detailed measured data for the verification of the physical representation provided by the CFD code. This requires that the data be taken and presented in a form and level of detail consistent with CFD requirements and that the accuracy of the experimental data be thoroughly documented and understood. The ideal test case should thus provide:

- a) Accurately measured model shape and surface finish.
- b) The actual position and motion of all points of the model, including both static and dynamic elastic deformations.
- c) Well defined state of the boundary layer on the model.
- d) Inflow and outflow conditions.
- e) Wall conditions and wall boundary layer.
- f) Specification of support interference
- g) Specification of the accuracy of the measured data.

After a thorough screening of the candidate test cases available for general distribution, it was found that ideal test cases are rare indeed, so the acceptance criteria had to be dramatically modified to the minimum requirements of knowing the geometry, and the motion, as accurately as possible. Nevertheless the authors believe the test cases included in the database to be generally of very high quality. Wherever possible experiments have been selected which include test points with different levels of physical difficulty, so that the CFD researcher can use a staircase approach to the problem of validating the code.

## **COMPUTATIONAL RESULTS**

In addition to the experimental data, the database includes computational results. Before a code can be validated, the developer must verify that it solves accurately the mathematical model of the real world that it uses. Given the lack of analytical solutions to the 3-D versions of the various sets of equations of interest to CUA, verification is best achieved by means of comparison with another computational

solution of the same set of equations.

To this aim a benchmark exercise was performed on the F-5 wing. Computational results covering the whole spectrum from Transonic Small Perturbations to Navier-Stokes codes were generated and are provided in the database, thus facilitating the verification of the new code against the same level of physical modeling. Some results of this exercise are presented in another paper of this meeting.

Additionally, attempts have also been made to complement each experimental data set with an example of a numerical calculation of at least one of its test points. These results may also be useful in cases where the CFD developer finds intriguing differences with experimental data, which cannot be attributed in a straightforward way to deficiencies in the numerical model, or in the test. Comparison with another computational result may clarify whether code improvement is required. Unfortunately it has not been possible to obtain numerical results for all the test cases, but the door is left open for interested groups to submit their calculations to complete the picture. These 'late arrivals' could be compiled as an addendum to the database.

No claim is made that these, or any of the other CFD solutions included, are free of discretization or solution errors. They should be treated as examples of what people with experience in the field have produced using mature codes, but not as absolute truth.

## **ORGANIZATION OF THE DATA BASE**

The compendium includes 20 self-contained test cases, which are summarized in Table 1. They address different phenomena, namely:

- Flutter
- Buffet
- Stability & Control
- Dynamic Stall
- Cavity Flows
- Store Separation

For each test case the following information is provided:

- A brief overview of the purpose and salient features of the experiment.
- A standard form (the same prepared in AGARD Report 702, which was considered to be still appropriate and difficult to improve) with the key information about the test conditions and equipment that a user may require.
- An example of the layout of the data files provided.
- Figures and pictures to illustrate the case.
- The data itself is provided in machine-readable form in a CD-ROM that accompanies the publication.

Whenever there are associated CFD results, they are contained in an accompanying chapter.

## OVERVIEW OF THE CASES

Most of the test cases provided are well known ones, which have already been extensively reported in symposia and/or scientific journals. A brief description of those more relevant for aeroelastic applications is provided in the following.

### F-5 Wing + Tip Store

The database starts with the well-known F-5 wing tested at the High Speed Wind Tunnel of NLR [1]. The original purpose of the experiment was to determine the unsteady airloads characteristics on a representative fighter type wing oscillating in pitch. It constitutes a very comprehensive data set, which progressively builds up in geometric complexity from the clean wing to a wing with a tip launcher and an A-A missile (Fig. 1). From a computational point of view, the clean wing case can be considered as rather benign, as it involves only small static angles of attack, small amplitudes of oscillation and limited viscous effects. This fact together with its simple geometry and wide range of Mach numbers tested (from subcritical to low supersonic) make it an ideal 'first case' in the validation process of a new code. This was the main reason why it was selected for the benchmark exercise mentioned before. On the other hand, the wing plus launcher plus missile cases provide excellent opportunities to check the ability of the code to tackle rather complex geometries.

### Rectangular Supercritical Wing

The Rectangular Supercritical Wing model RSW [2] was tested at the NASA Langley Transonic Dynamic Tunnel with the specific aim of obtaining data for CFD comparison. It has a simple low aspect ratio unswept rectangular planform with no twist, a constant 12% thick supercritical airfoil and a tip of revolution. The model undergoes pitching oscillations. Data is provided corresponding to a wide range of flow conditions from low subsonic to strong transonic well beyond the design Mach number, as would be required for flutter verification beyond cruise conditions. A broad range of reduced frequencies is also covered. Special care has been taken to select data points, which illustrate the trends with Mach number, reduced frequency, amplitude of oscillation and static angle of attack. Some cases for high angle of attack (at low speed) and others for the effect of transition have been also included. Despite its simple geometry, the case has proved to be a difficult one to calculate. Typically for low-aspect ratio rectangular wings, transonic shock waves tend to sweep forward from root to tip such that there are strong three-dimensional effects. Additionally it has been found to be very sensitive to viscous and transition effects, specially on the undersurface.

### Benchmark Model Program

NASA's Benchmark Model Program (BMP) tested a series of models in the Langley Transonic Dynamics Tunnel with the primary objective of assisting in the evaluation of aeroelastic CUA codes. The present database includes results from three of the models, all of which have an identical rectangular planform. The first model has a NACA0012 airfoil which develops strong shocks [3]; the second model has a supercritical SC(2)0414 airfoil which generates weaker hard to capture shocks [4]; and the last model, called the Benchmark Active Controls Technology BACT [5], has again a

NACA0012 airfoil but with a trailing edge control surface, and a pair of independently actuated upper and lower surface spoilers. All the models were mounted on the PAPA (Pitch and Plunge Apparatus) 2 Degrees of Freedom dynamic system, which allows rigid models to undergo flutter. Cases corresponding to classical pitch-plunge flutter, stall flutter and shock-induced plunge flutter are included. The actual wing motion together with the corresponding pressures are provided, thus allowing a staircase approach to validation, from forced oscillations (using the motion as input) to a 'simple' aeroelastic simulations (using the known elastic characteristics of PAPA). Finally the transfer functions of control surface inputs measured with the BACT can be used to validate aeroservoelastic codes.

### Clipped Delta Wing

The Clipped Delta Wing CDW model was also tested in the NASA Langley Transonic Dynamics Tunnel [6]. The planform was derived by simplifying a proposed Boeing design for a supersonic transport, resulting in a trapezoid wing with an unswept trailing edge and without twist and camber (Fig. 2). The model undergoes pitching and trailing edge control surface oscillations. A rather thick (for a supersonic transport) 6% symmetrical circular arc section was used, which very much enhances transonic effects. Additionally the highly swept sharp leading edge separates the flow at relatively low angles of attack forming a leading edge vortex. Rapid changes in shock wave position over a small Mach range, sometimes in conjunction with the leading edge vortex makes this a challenging case for any numerical method.

### Supersonic 2D Wing with Control Surface

This case was tested at ONERA S2 to obtain a database of the unsteady behavior of control surfaces in high supersonic conditions [7]. It consists of a 5.5 aspect ratio rectangular wing with a 7% symmetric bi-convex airfoil and an oscillating trailing edge flap (Fig. 3). The model had also a spoiler, but no data corresponding to it is provided in the present database. Pressures were measured at the mid semi-span section, which at the supersonic Mach numbers tested (1.65, 2.0 and 2.5) is effectively in 2D conditions. Test points are provided that illustrate the effect on the unsteady airloads of: Mach number, steady angle of attack, mean flap deflection, flap oscillation amplitude and oscillation frequency.

### SST Arrow Wing with Oscillating Flap

This model of a double-swept-back arrow wing with a fuselage and an oscillating trailing edge flap (Fig.4) representing a SST was tested at NAL's 2mx2m transonic wind tunnel with the specific purpose to accumulate validation data for CUA and ACT (Active Control Technology) codes [8]. A NACA0003 airfoil was used, resulting in a very thin wing with non-negligible static and dynamic elastic deformations, which were carefully monitored tracing optical targets installed on the wing surface. Information on pressures and actual motion due to elastic deformation is provided, thus constituting a good test of the ability of the code to handle both rigid body and elastic motions. Results are included for different transonic Mach numbers, mean flap positions and frequencies of oscillation.

## BGK Airfoil Buffet

This model of a BGK No. 1 supercritical airfoil was tested at the IAR 2D High Reynolds Test Facility to investigate its shock induced buffet characteristics [9]. Very rich pressure information at different Mach/AoA combinations outside, near, and well inside the buffet onset boundary is provided. Additionally, skin friction measurements are available; allowing the CFD developer to monitor the merging of the shock induced separation bubble with the trailing edge separated region.

## M2391 Diamond Wing Buffet

The M2391 model (Fig. 5) tested at DERA Bedford 13ftx9ft low speed wind tunnel [10] is a low mass, high stiffness model designed to obtain data of the aerodynamic excitation arising from unsteady separated flow without the interferences due to model vibration and/or support natural frequencies. It is a 40° sweep diamond wing with a streamwise clipped tip. Two interchangeable fuselages were tested, respectively rectangular and chined, with the former providing a perpendicular wing-fuselage interface, and the later allowing the study of buffet due to mixed vortical flow. Very rich pressure information for angles of attack up to 30° is included, thus providing an excellent test case to validate the buffet part of any buffeting prediction code.

## Straked Delta Wings

These two different straked delta wing models (Figs. 6) were tested respectively in NLR's LST [11] and HST [12] wind tunnels with the aim to improve understanding of unsteady loading on straked fighter like wings during pitch oscillations and maneuvers. They present a wide range of flow topologies, from attached to vortex breakdown over the whole model. Additionally the transonic test includes cases with shock induced trailing edge separation and LCO. The data points selected cover all the different flow types, including the influence of Mach number, static incidence and sideslip, amplitude and frequency of oscillation. The resulting database constitutes a real challenge of any fluid dynamics code.

## CONCLUSIONS

The work of RTO WG-003 aims at collecting into a single document, computational and experimental data that can be used to verify and validate Computational Unsteady Aerodynamic codes. It is recognized that the present database still has many gaps, which are due either to the lack of a suitable experiment, or the authors not being aware of its existence, or its results being classified. Additional contributions of experimental and/or numerical data are very welcomed

## ACKNOWLEDGMENTS

Funding for this work was provided by AGARD/RTO, the different AGARD/RTO national delegations, and the individual member's organization. Their contributions are gratefully acknowledged.

## REFERENCES

- [1] Tijdeman, H.; van Nunen, J.W.G.; et al.; "Transonic Wind Tunnel Test of an Oscillating Wing with External Store". Parts I: to IV"; NLR-TR-78106 U; 1978
- [2] Ricketts, R. H.; Sandford, M. C.; Watson, J.; Seidel, D. A.; "Subsonic and Transonic Unsteady- and Steady-Pressure Measurements on a Rectangular Supercritical Wing Oscillated in Pitch; NASA TM 85765.; 1984.
- [3] Rivera, J.A.; Dansberry, B.E.; Farmer, M.G.; Bennett, R.M.; Durham, M.H.; Silva, W.A.; "NACA0012 Benchmark Model Experimental Flutter Results with Unsteady Pressure Distributions". NASA TM-107581; 1992
- [4] Dansberry, B.E.; Durham, M.H.; Bennett, R.M.; Rivera, J.A. Jr.; Silva, W.A.; Wieseman, C.D.; "Experimental Unsteady Pressures at Flutter on the Supercritical Wing Benchmark Model"; AIAA Paper 93-1592; 1993
- [5] Scott, R.C.; Hoadley, S.T.; Wieseman, C.D.; "The Benchmark Active Control Technology Model Aerodynamic Data"; AIAA 97-0829; 1997
- [6] Hess, R. W.; Cazier, F. W., Jr.; Wynne, E. C.; "Steady and Unsteady Transonic Pressure Measurements on a Clipped Delta Wing for Pitching and Control-Surface Oscillations"; NASA TP-2594; 1986
- [7] Naudin, P.; "Results d'essais d'une maquette bi-dimensionnelle munie d'un spoiler et d'un gouverne en supersonic"; ONERA Report 24/5115RN031R; 1996
- [8] Tamayama, H.; Miwa, H.; Nakamichi, J.; "Unsteady Aerodynamic Measurements on an Elastic Wing Model of SST"; AIAA 97-0836; 1997
- [9] Lee, B.H.K.; Ohman, L.H.; "Unsteady Pressure and Force Measurements Associated with Transonic Buffeting of a Two-Dimensional Supercritical Airfoil"; National research Council of Canada AN-14; 1983
- [10] Lynn, R.; Gibb, J; Shires, A; "Buffet tests on a 40 degree diamond wing – Model M2391"; DERA/MSS4/TR98309/1.0; 1998
- [11] Cunningham, A.M. Jr.; den Boer, R. G.; et al; "Unsteady Low Speed Wind Tunnel Test of a Straked Delta Wing oscillating in Pitch. Parts I to VI"; NLR TR 87146; 1987
- [12] Cunningham, A.M. Jr.; den Boer, R. G.; et al; "Unsteady Transonic Wind Tunnel Tests on a semi-span Straked Delta Wing Model, oscillating in Pitch. Parts I to III"; NLR-CR 93570; 1993

Table 1. Test cases

Test case	Configuration	Motion	Speed Regime	CFD?
NLR F-5 Wing & Wing+Store	Wing+Missile	Pitch	Subsonic to Supersonic	YES
NASA RSW	Wing	Pitch	Subsonic to Transonic	
NASA BMP Rectangular Wing	Wing	Pitch Plunge	Subsonic to Transonic	
NASA BMP BACT	Wing + Flap + Spoiler	Flap spoiler	Subsonic to Transonic	YES
NASA Clipped Delta Wing	Wing + Flap	Pitch Flap	Subsonic to Supersonic	YES
ONERA 2D Supersonic TE Control	Airfoil + Flap	Flap	Supersonic	
RAE Tailplane	Wing	Pitch	Supersonic	
NAL SST	Wing + Flap + Fuselage	Flap	Transonic	
IAR BGK Airfoil	Airfoil	Buffet	Transonic	
DERA Model 2391	Wing + Fuselage	Buffet	Subsonic	
IAR SDM Fin Buffet	Wing + Fuselage + Fin	Buffet	Subsonic	
IAR 65° Delta Wing	Wing + Centerbody	Roll	Subsonic	YES
DLR 65° Delta Wing	Wing + Centerbody	Pitch Yaw Roll	Subsonic	YES
NLR Low Speed Straked Delta Wing	Wing	Pitch	Subsonic	
NLR Transonic Simple Straked Delta Wing	Wing	Pitch	Subsonic to Transonic	YES
AEDC WICS	Cavity	-	Transonic	YES
BAe/DERA Cavity	Cavity	-	Subsonic to Supersonic	
DLR COM TWGI	Cavity	-	Transonic Supersonic	
Glasgow U. Dynamic Stall	Airfoil Wing	Pitch	Subsonic	
AEDC Wing/Pylon/Moving Store	Wing + Pylon + Store	Drop	Transonic Supersonic	



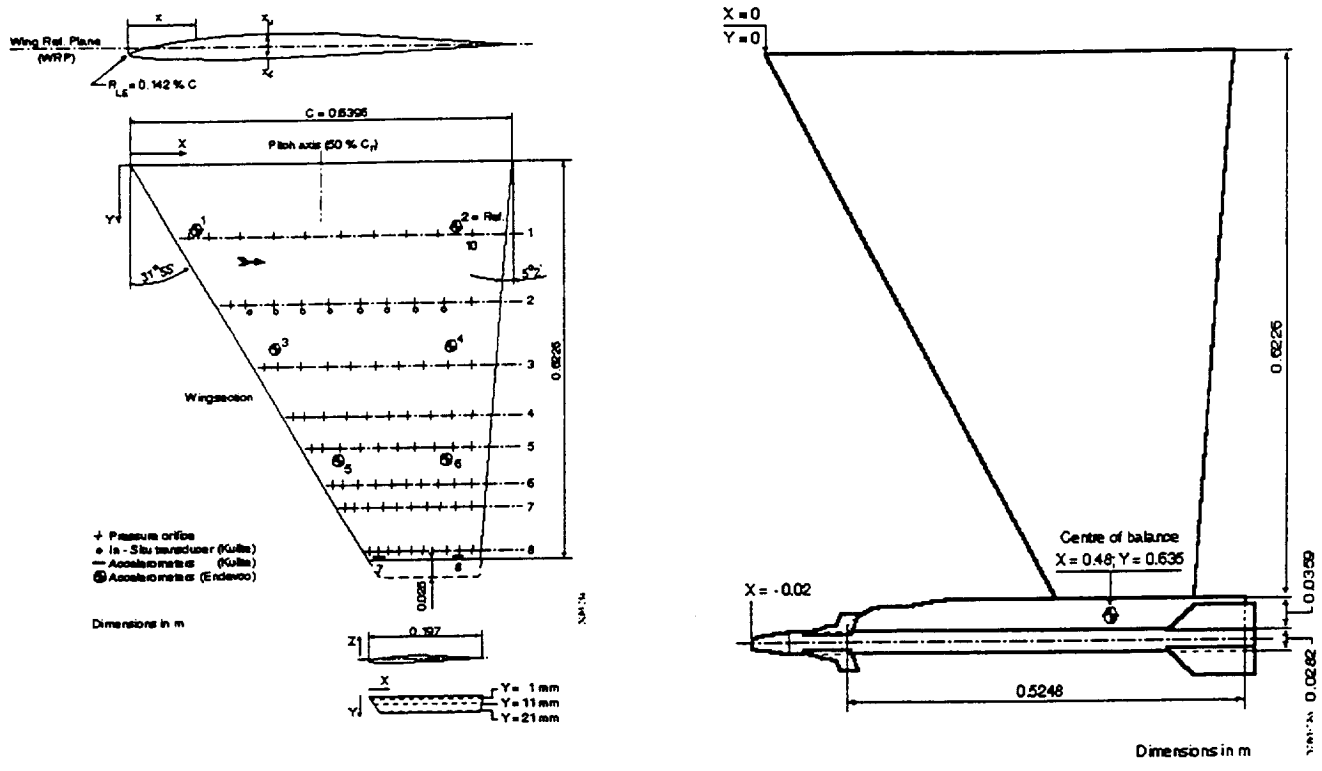

Fig. 1 F-5 Wing alone and Wing + Tip Missile

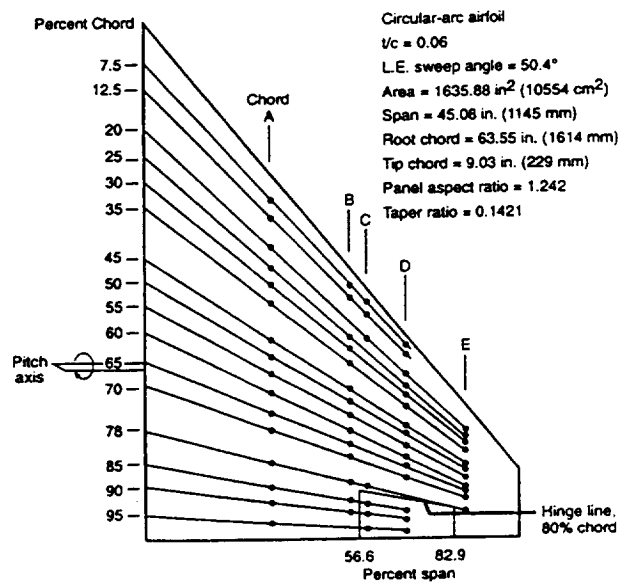

Fig. 2 Clipped Delta Wing



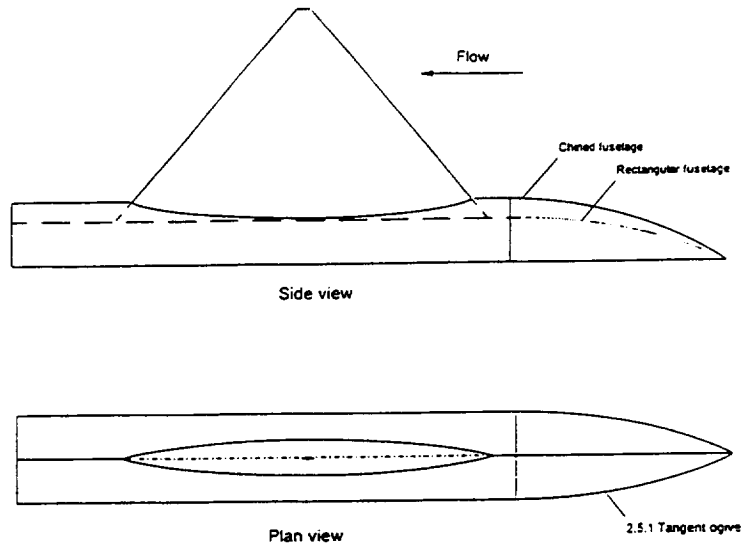

Fig. 5 M2391 Diamond Wing

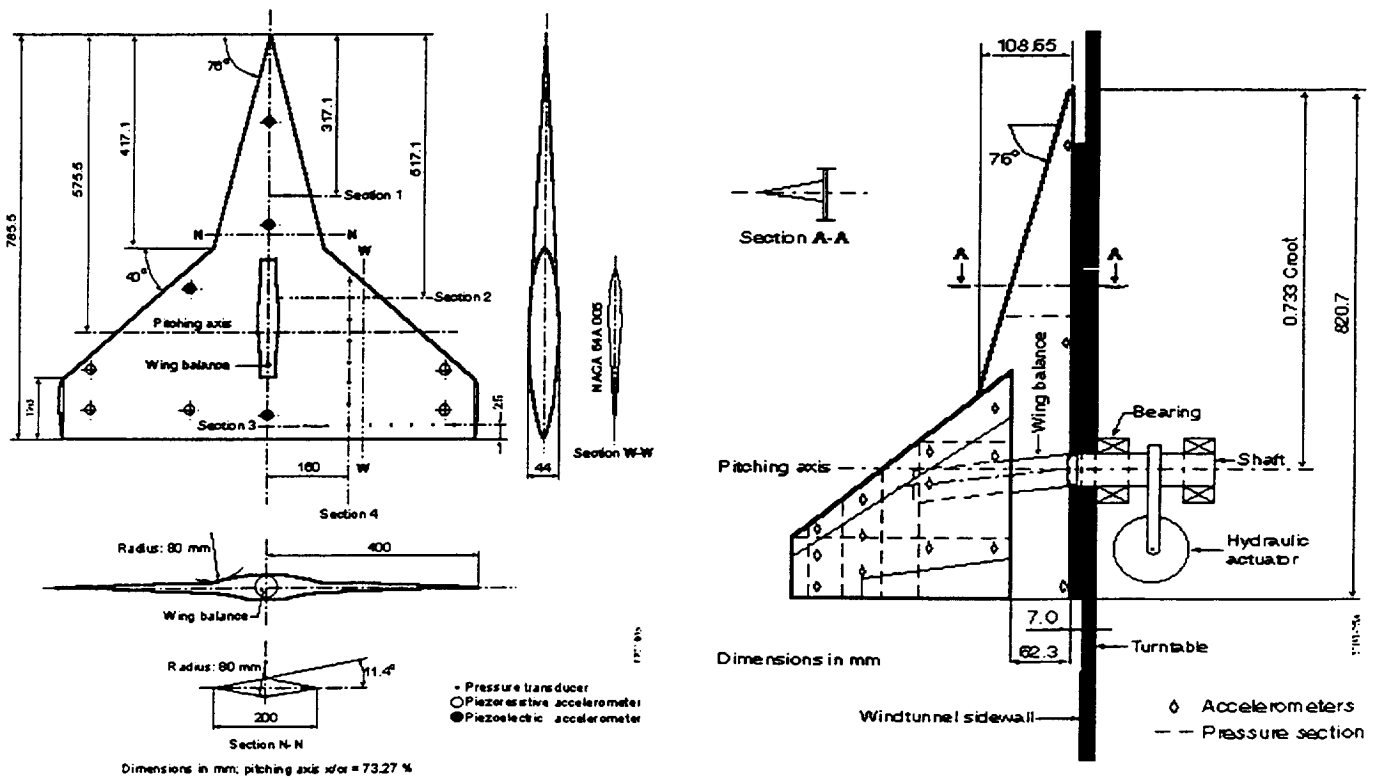

Fig. 6 Subsonic (Left) and Transonic (Right) Straked Delta Wings

