

NASA/CP—1999-208918

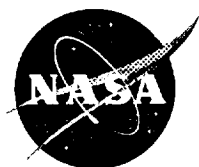

# Workshop on Aerosols and Particulates From Aircraft Gas Turbine Engines

Proceedings of a conference held at Ohio Aerospace Institute  
and sponsored by NASA Glenn Research Center  
Cleveland, Ohio  
July 29–30, 1997

National Aeronautics and  
Space Administration

Glenn Research Center

---

June 1999

We apologize for being so late in publishing this workshop conference. Please note that the intent is to print the content as it was presented at the conference and any recent editing/updates do not include the knowledge learned between then and now.

Available from

NASA Center for Aerospace Information  
7121 Standard Drive  
Hanover, MD 21076  
Price Code: A12

National Technical Information Service  
5285 Port Royal Road  
Springfield, VA 22100  
Price Code: A12

## FOREWORD

The Workshop on Aerosols and Particulates from Aircraft Gas Turbine Engines was held on July 29-30, 1997 at the NASA Lewis Research Center in Cleveland, Ohio. Participants consisted of approximately 100 United States citizens representing gas turbine industries, government agencies and the academic world. An attendance list is included in the proceedings. Their expertise included engine and airframe design, combustion processes and kinetics, atmospheric science, fuels, flight operations and instrumentation.

Although much work has been accomplished quantifying particulates from gas turbine engines, and reported as SAE Smoke Number, comparatively little is known regarding their characterization and formation mechanisms. With growing climatological concerns regarding the potential effects of aerosols and particulates on cloud formation this area has been identified as an emerging research field. The purpose of this workshop was to begin to address these issues in a systematic manner. Specifically, the objective was to evolve the elements of a prioritized program plan for the measurement and characterization of particulates, aerosol precursors and aerosols from aero gas turbine combustors and engines.

The workshop was conducted in three phases:

- Phase I consisted of a series of relevant presentations. Authorship credit is listed with each paper in these proceedings
- Phase II consisted of segregating attendees by their areas of expertise into three working groups consisting of trace chemistry, instrumentation and venues/procedures. The working groups employed participative discussions to achieve consensus in identifying and prioritizing areas of greatest concern
- Phase III consisted of working groups presenting their results to all attendees. This was followed by general discussions on each topic.

Subsequently, workshop results were incorporated by NASA into a research program in support of the High Speed Research and the Advanced Subsonic Programs.

Richard W. Niedzwiecki  
NASA Glenn Research Center



# TABLE OF CONTENTS

Executive Summary Frederick Dryer, Princeton University; and Richard Niedzwiecki, NASA Glenn.....	1
Workshop on Aerosols and Particulates from Aircraft Gas Turbine Engines Richard Niedzwiecki, NASA Glenn; and Frederick L. Dryer, Princeton University.....	5
Problem To Address—Local Air Quality Richard W. Niedzwiecki, NASA Glenn.....	21
Statement of Problem: Engine and Near-Field; Aerosol and Particulate R.C. Miake-Lye, Aerodyne Research, Inc.....	45
Potential Climate Impacts of Engine Particle Emissions S. Randy Kawa, NASA Goddard.....	55
UMR Mobile Aerosol Sampling Facility and Smoke Meter D.E. Hagen, P.D. Whitefield, J. Paladino, and H.V. Lilienfeld, University of Missouri—Rolla.....	61
Airborne Observations of Aerosol Emissions From F-16 Aircraft B.E. Anderson, W.R. Cofer, and D.S. McDougal, NASA Langley.....	83
Workshop on Aerosols and Particulates from Aircraft Gas Turbine Engines Harvey V. Lilienfeld, McDonnell Douglas Corporation.....	101
Engine Test and Measurements Chowen Chou Wey, NASA Glenn.....	123
Hot Section Modeling I.A. Waitz and S.P. Lukachko, MIT Aero-Environmental Research Laboratory; R.C. Miake-Lye, R.C. Brown, and M.R. Anderson, Aerodyne Research Inc.....	135
Charge to Working Groups Sol Gorland and Martin Rabinowitz, NASA Glenn.....	163
Trace Chemistry Krishnan Radhakrishnan, NASA Glenn; and Philip Whitefield, University of Missouri—Rolla.....	177
Instrumentation Working Group Summary Michelle Zaller, NASA Glenn; and Richard Miake-Lye, Aerodyne Research, Inc.....	179
Aerosols and Particulates Workshop Sampling Procedures and Venues Working Group Summary Peter Pachlhofer, NASA Glenn; and Robert Howard, Sverdrup, Arnold Engineering Development Center.....	187
Attendees List.....	239



## EXECUTIVE SUMMARY

Frederick Dryer  
Princeton University  
Princeton, New Jersey

and

Richard Niedzwiecki  
NASA Glenn Research Center  
Cleveland, Ohio

Sulfur issues with regard to atmospheric effects of aircraft emissions of aerosol and particulates have been discussed in detail in several recent reports (e.g., Albritton et al., 1996; Friedl et al., 1997). The National Research Council (NRC) Panel on Atmospheric Effects of Aviation (PAEAN) has recently reviewed the Emissions Characterization and Near-Field Interactions Elements of the Atmospheric Effects of Aviation Project (AEAP) research plan to appraise the projects results and to suggest how to best reduce remaining uncertainties in the assessment. (report to be issued, 1997). The lack of sulfur oxides effects on emissions from engines, and the dilemma that atmospheric plume data apparently show that SO<sub>2</sub> oxidation by OH in the aircraft wake is not the dominant source of condensed sulfate have motivated the NRC to recommend that prioritization of emissions characterization by the Engine Exhaust Trace Chemistry (EETC) Committee (Miake-Lye, 1992) characterization of sulfur oxides emissions be updated accordingly. This prioritization was originally developed to address issues associated with the Atmospheric Effects of Stratospheric Aircraft (AESAs), was updated to include the Subsonic Assessment (SASS) at the inception of the program. Sulfur oxides characterization had been given a lower priority in that report, since the importance of aerosols to climatic effects had not been expected to be so closely coupled to emissions issues at the exit plane of the engine and the near-field production of aerosols. The recommendations of the NRC were to raise SO<sub>x</sub> emissions characterization to a high priority, and to perform characterization studies on full scale engines characteristic of recent and imminent additions to the fleet.

The chair of the EETC committee (F.L. Dryer, Princeton) and NASA-Lewis recently organized a workshop (Niedzwiecki and Dryer, 1997) in response to the suggestions of the NRC and to develop consensus among experts in the field as to important issues and venues to be considered. The charges to the workshop were to:

- Reconsider the prioritizations of engine trace constituents for assessing impacts of aircraft, including the species to be measured, and the accuracy with which measurements are needed for addressing the AEAP assessments.
- Review and update both extractive and insitu measurement techniques for achieving the characterization needs.
- Determine the best venues and venue characteristics for performing the necessary measurements.

The general consensus of the workshop concurred that better characterization of SO<sub>x</sub> and particulate emissions for a wider variety of engines are needed. The major points of agreement with regard to NRC recommendations were:

- Consign a higher priority to particulate and aerosol research (designated as SO<sub>2</sub>, SO<sub>3</sub>, OH).

- Refine instrumentation techniques to measure aerosols and aerosol precursors.
- Test actual commercial engines - as new as possible.
- Military engines are a good choice of test venue if commercial engines are not available.
- Perform piggyback tests where possible - request aid from our advisory committees to obtain engine venues.
- Validate NO<sub>x</sub>, CO and THC emission concentrations under cruise conditions -- develop correlations for performing this.

However, participants believed that the recommendations of the NRC panel need to be further augmented to give the community an appropriate level of understanding of aerosol and aerosol precursor production and fate in aero-propulsion engines. While characterization of engine emissions of SO<sub>2</sub>, SO<sub>3</sub> and OH are central to addressing aerosol/particulate effects, other constituents also impact the aerosol/particulate problem. These include particulate matter emitted from the aircraft, consisting of soot (carbon non-volatile), soot precursor components and PAH (non-volatiles), metals and silica emissions, and nitric acid.

Interpretations of recent measurements and current modeling studies indicate that growth of aerosol precursors occurs in the engine hot section downstream of the combustor. Hot section turbine cooling air appears to play a major role in defining aerosol precursors at the exit plane of the engine. The production is also related to the initial conditions entering the hot section, i.e. combustor emissions themselves. These characteristics suggest that the production of aerosol precursors is engine/hot section design dependent. Modeling of hot-section and nozzle interactions, including the detailed chemical kinetic and cooling air issues were concluded to be critical to understanding particulate/aerosol engine emissions characteristics, interpreting specific engine measurements, correlating emissions measurements across engine types, generating accurate predictions of emissions from future engine designs, and defining emission control parameters and strategies. Modeling will require further development and validation of modeling tools and validated kinetic/transport information on sulfur oxides kinetics and interactions with combustion products and other emissions species, including gas phase and heterogeneous components. Fundamental program elements involving both numerical modeling and fundamental experimental efforts were concluded to be important to meeting these needs. Determining appropriate hot section initial conditions was also viewed as essential, both in modeling the hot section/nozzle interactions, and in providing best estimates of the calculated nozzle exit plane parameters for input to modeling the near-field interactions down stream.

Engine tests are critically important to defining aerosol/particulate precursor issues. However, engine test venues remain very expensive and difficult to access. A typical test, piggybacked upon engine development testing costs approximately \$500K. A dedicated engine test would cost more than an order of magnitude more. Manufacturers are (understandably) reluctant in making available their newest commercial engines. Thus rig tests on combustors and hot sections, which are much lower cost and readily available on a weekly basis, are essential to obtaining aerosol/particulate precursor data and technology base. In test rigs, flow, operational, and fuel parameter issues can be varied in a systematic manner to understand the non-linear fluid dynamic, chemical kinetic, and heat transfer issues in the presence of real-flow conditions. Given successful development of modeling



tools, data from combustor rigs can be used to determine impacts of engine design parameters prior to development of full-scale prototypes, and engine design differences among various engine designs and classes can be fully assessed. Specific engine tests to accomplish this task will be inordinately costly and thus are likely to yield results in only a small number of engine classes and for limited engine operating envelope conditions.

### **Workshop Organization:**

Prof. Dryer, the co-chair of the workshop, opened the discussions with a brief review of the relationships of the High Speed Research (HSR) and the Advanced Subsonic Technology (AST) programs, and the missions of the AEAP and its sub-elements, the AESA and SASS projects. A brief history of the efforts of the EETC Committee, which Prof. Dryer chairs, was then given, including a review of the committee's purpose, and goals. Recommendations of the EETC Committee prior to recent technical revelations concerning the importance sulfur and aerosol/particulate emissions on both subsonic and high speed propulsion impacts on upper tropospheric and stratospheric ozone and upper tropospheric climatic issues were reviewed, and a synopsis of evidence supporting and questions concerning the role(s) of aerosol/particulates was presented.

A brief discussion of how sulfur oxidation kinetics interactions in the hot-section and nozzle play a role in the formation of aerosol precursors was given by Dr. Dryer, and the present deficiencies in validated sulfur oxidation kinetics were summarized. Mr. R. Niedzwiecki then reviewed the present programmatic issues addressing aerosol particulate testing in engines, and also added some discussion as to the relationship of the present needs to those likely to develop in consideration of the recent discussion of proposed EPA PM<sub>2.5</sub> emissions regulations and impacts in the vicinity of airports. Dr. R. Miake-Lye gave a description of the current status of the emissions measurement activities at both the engine exit plane and the aircraft near-field plume which led to the statement of problem. Dr. R. Kawa then reviewed the potential climate impact issues which point to a need for more definitive understanding of the aerosol/particulate and aerosol precursor problems.

To apprise workshop participants of other pertinent background, the following five technical overviews were presented:

- UMR MASS and Smoke Number - P Whitefield, D. Hagen, University of Missouri, Rolla
- Airborne Observations of Aircraft Aerosol Emissions - B. Anderson, NASA LaRC
- Data Correlation on Soot Emissions - H. Lilenfeld, Boeing
- Engine Test and Measurements - C. C. Wey, NASA LeRC
- Engine Hot Section Modeling - I. Waitz, S. Lukachko, MIT

To assist in developing a research plan, and to update the present EETC considerations with regard to aerosol/particulate issues, the workshop participants were then charged with addressing the following matters:

- Measurement Priorities-
  - What Should be measured?

- What are the measurement requirements which should be met to best impact assessment needs?
- Measurement Techniques-
  - What Techniques are available?
  - What is the status (research or applied tools?) of the techniques?
  - What developments are needed to support measurements?
- Measurement Venues-
  - What in-flight measurements are needed? What venues are available?
  - What engine tests are needed? What venues are available?
  - Are sub-element tests (combustor development rig, sector, etc.) desirable? If yes, what are the venues?
  - Are fundamental theoretical, experimental, and/or computational efforts needed for understanding, correlating, and/or applying results?

The Workshop participants were then accordingly divided into three plan/working groups to consider the above problems. The working groups were:

- Trace Chemistry
- Instrumentation
- Sampling Procedures and Venues

Participants were encouraged to participate in the group(s) of specific interest to them, and the co-chairs worked in all three groups to assist in coordination. Additionally, the co-chairs of each group made presentations to all workshop participants describing the initial directions of inquiry after about five hours of deliberations. After an additional six hours of discussions, the group chairs presented summary overviews of their discussions for critical comment and coordination by all workshop participants. Following discussions and suggestions from the participants, summary reports of each working group were prepared by the group chairs. These summaries were reviewed by the respective working group chairs and the final summary reports and materials from each of these group are presented here.

Richard Niedzwiecki  
NASA Glenn Research Center  
Cleveland, Ohio

and

Frederick L. Dryer  
Princeton University  
Princeton, New Jersey

**HSRP** - High Speed Research Program

-developing new technologies of high speed aircraft propulsion (LPP- lean, premixed, pre-vaporized, RQL- rich-quench-lean designs).

**AESA** - Atmospheric Effects of Stratospheric Aircraft

-assessing primarily ozone perturbations effects of future high speed aircraft on primarily the 18-22 km region of the stratosphere.

**SASS** - Subsonic Assessment Program

-assess ozone perturbation effects as well as radiative (climatic) impact of subsonic aircraft emissions from both ozone layer/greenhouse effects and aerosol/cloud cloud scattering.

**AEAP** - Atmospheric Effects of Aircraft Project

-coordinating program for AESA and SASS projects.

# **Engine Exhaust Trace Chemistry (EETC) Committee (1992)**

**F. Dryer (Chair)**  
**J. Facey, NASA-Hq**  
**D. Fahey, NOAA**  
**A. Hansen, LBNL**  
**D. Hagen, U. Missouri, Rolla**  
**P. Heberling, GE Aircraft Engines**  
**R. Howard, AEDC**  
**C. Jacimowski, NASA-Langley**  
**H. Lilenfeld, McDonnell Douglas**  
**S. Langhoff, NASA-Ames**  
**R. Lohman, Pratt & Whitney**  
**N. Marchionna, Stirling Thermal Motors Inc.**  
**R. Miake-Lye Aerodyne Research Inc.**  
**R. Niedwiecki, NASA-LeRC**  
**R. Oliver, IDA**  
**R. Pueschel, NASA-Ames**  
**C.C. Wey, ARL/NASA-Le-RC**  
**P. Whitfield, U Missouri, Rolla**  
**J. Wormhoudt, Aerodyne Research Inc.**

# **Engine Exhaust Trace Chemistry (EETC) Committee**

Purpose:

(1992) -

Provide guidance and recommendations to HSRP/AESA in developing a future engine emissions measurement and assessment programs.

(1993)-

Provide guidance and recommendations on modifications/new issues raised by added consideration of SASS program, coordinated with AESA through the AEAP.

# **Engine Exhaust Trace Chemistry (EETC) Committee**

## **Committee Charges:**

- Prioritize engine trace constituents for assessing impacts of aircraft.**
- Assess both extractive and insitu measurement techniques.**
- Determine best venues for performing the necessary measurements**

# **Engine Exhaust Trace Chemistry (EETC) Committee**

## **-Prioritize engine trace constituents for assessing impacts of HSCT's:**

- Those which directly impact ozone chemistry:
  - **NO, NO<sub>2</sub>, HNO<sub>3</sub>, NO<sub>y</sub>**
- Those which affect wake/plume chemical condensation phenomena:
  - **total particulate mass,**  
size distribution, reactivity,  
**SO<sub>2</sub>/SO<sub>3</sub>, H<sub>2</sub>SO<sub>4</sub>, OH, NMHC**
- Those which might serve as design optimization indicators in engine development.
  - **CO<sub>2</sub>**

# Sulfur Content of Jet Fuels

Current Regulation:  $\text{SO}_2 \text{ EI}_{\text{reg}} < 6 \text{ g/kg-fuel}$

- Actual amount is typically a factor of ten less than current regulation.
- Eventual fuel sulfur content?  
It's difficult to make it universally zero.



## SO<sub>x</sub> AND NO<sub>x</sub> REACTIONS

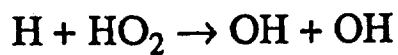
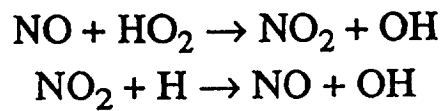
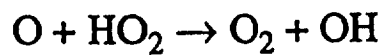
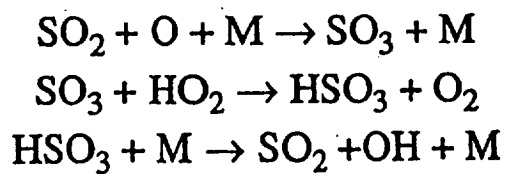

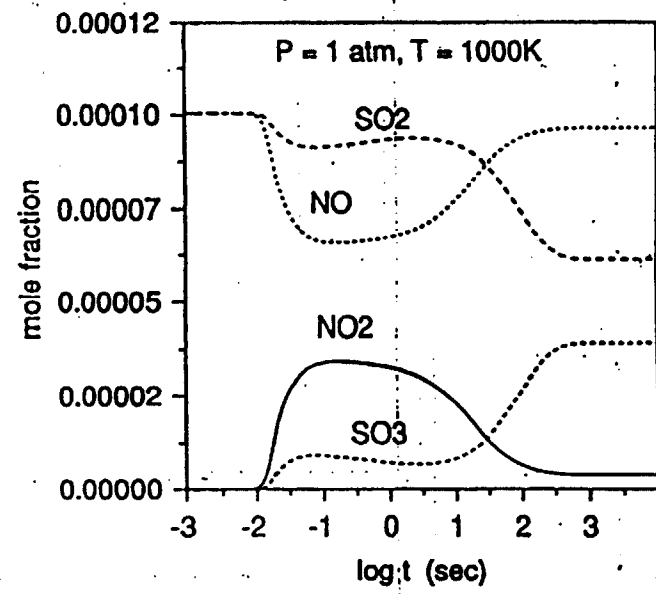
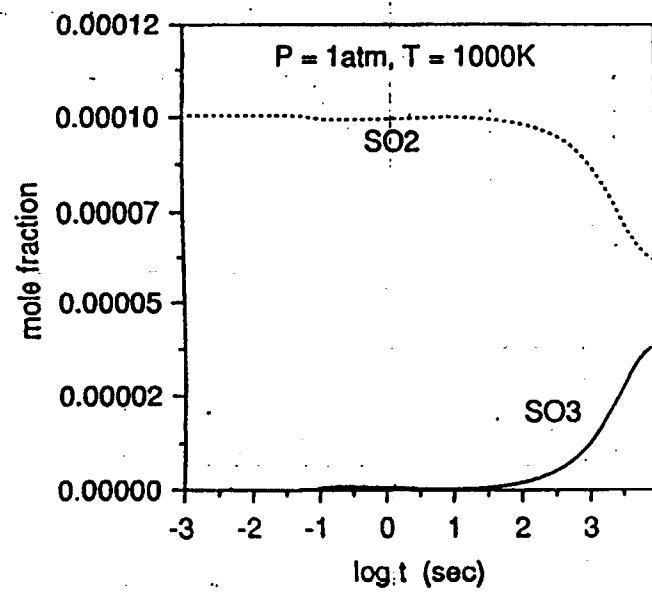

# SO<sub>3</sub> / SO<sub>2</sub> RATIO

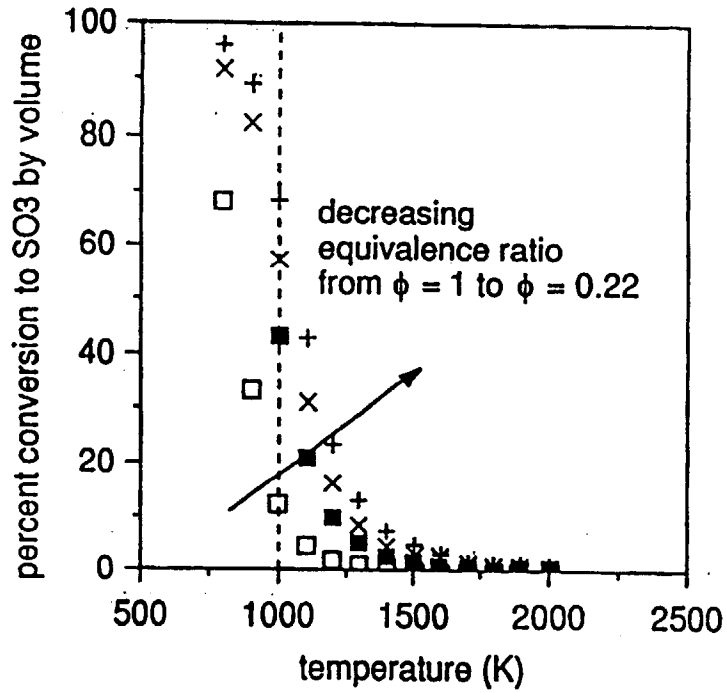

from Brown et al., Geophysical Research Letters, 23, 3603, 1996

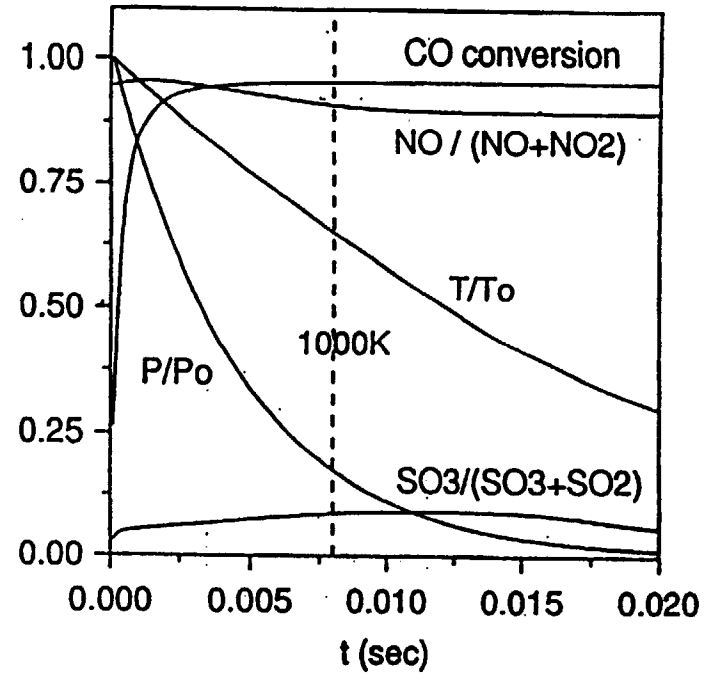

isentropic expansion  
 T<sub>o</sub> = 1500K  
 P<sub>o</sub> = 10 atm

# **Organization of Workshop**

## **This Afternoon-**

### **-Charge to Working Groups**

Sol Gorland, LeRC

### **-NASA Preliminary Plan/Working Group Expectations**

- Trace Chemistry**
- Instrumentation**
- Procedures/Venues**

### **-Working Group Deliberations**

## **Tomorrow-**

### **-Continuing Deliberations, Summary Report Development**

# Organization of Workshop

## **This Morning -**

### **- Background**

- Problem Definition

R. Niedzwiecki, LeRC

- Engine/Near Field A/P Issues

R. Miake-Lye, ARI, Inc.

- Climatology Issues

S. Baughcum, Boeing

### **- What we know (don't know) now**

- Smoke Number/MASS Results

P. Whitefield/D. Hagen, UMR

- Flight Measurements

W. Grose/B. Anderson, LaRC

- Data Correlation

H. Lilenfield, MDC

- Engine Test Venues and Measurements

C. Wey, LeRC

- Engine Hot-Section Modeling

Ian Waitz, MIT

## **Organization of Workshop**

### **This Afternoon -**

#### **- Charge to Working Groups**

Sol Gorland, LeRC

#### **- NASA Preliminary Plan/Working Group Expectations**

- Trace Chemistry**
- Instrumentation**
- Procedures/Venues**

#### **- Working Group Deliberations**

### **Tomorrow -**

#### **- Continuing Deliberations, Summary Report Development**

## **Workshop Objective**

**Develop a program plan for the measurement and characterization of particulates, aerosol precursors, from aircraft gas turbine combustors and engines.**

### **Issues:**

- Measurement Priorities
  - What should be measured?
  - Priorities?
  - Measurement requirements?
- Measurement Techniques
  - What techniques are available?
  - What needs to be developed?
- Measurement Venues
  - In flight?
  - Engine Tests?
  - Combustor Tests? (sector? rig?)
- Fundamentals for understanding/  
translating/applying results.

## Motivation

**Inflight plume measurements (1995) behind Concorde indicate high particulate/aerosol loading in near wake.**

- Result is indicative of a high of sulfur oxide conversion to sulfate, and data suggest that the dominant cause of conversion is not oxidation by OH.
- Mechanism for the observed degree of conversion is not yet fully rationalized. Increases in sulfate aerosol surface area in lower stratosphere may result in ozone depletion, and impact is maximized if the formation is in the near-wake/exhaust plume.
- Uncertainties in predicting impact of HSCT fleet result.



## Motivation (continued)

- Direct Relevance of high degree of SO<sub>2</sub> Oxidation unknown.
- Results suggest that SO<sub>2</sub>, SO<sub>3</sub>, OH, and additional aerosol/particulate (soot) characterizations in various venues, particularly behind aircraft engines are needed.
- Present work suggests that emission characteristics at the engine exit plane may differ from those at the combustor exit.
  - Hot section chemistry, fluid mechanics, cooling, and geometry can effect changes.
  - Chemical oxidative interactions of sulfur leading to sulfates are not well-characterized presently.



PROBLEM TO ADDRESS—LOCAL AIR QUALITY

Richard W. Niedzwiecki  
NASA Glenn Research Center  
Cleveland, Ohio

**OUR OBJECTIVES**

**EVOLVE A PROGRAM PLAN FOR THE MEASUREMENT AND CHARACTERIZATION OF PARTICULATES, AEROSOL PRECURSORS AND AEROSOLS FROM AERO GAS TURBINE COMBUSTORS AND ENGINES**

- o Characterize particulates and aerosols from jet engines
- o Develop a data base for the above - current & new engine emphasis
- o Develop a field instrument & techniques for measurement of particulates & aerosols

**FOCAL POINTS:**

- o Technology needs
- o Intrusive & non-intrusive instrumentation development
- o Test venues, procedures & special requirements

## Technology Plan continued

- Assemble preliminary plan and hold industry workshop.
  - Trace chemistry committee chair
  - Restrict attendance for more candid discussions?
  - Hold in Spring/Summer of 1997

# Engine Exhaust Constituents

- Gaseous: CO, CO<sub>2</sub>, H<sub>2</sub>O, NO<sub>x</sub>, THC
- Particles:
  - Solids: Particulates
  - Liquids: Aerosols
- Status
  - We do a good job measuring gaseous
  - We do a poor job with particles
    - New need
    - Smoke number inadequate

# Particles - Solids and Vapors

## Particulates:

- Carbon based: THC, Sulfur, NO<sub>y</sub>, etc. on surface
- Relatively nonreactive - (hydrophobic)
- Several microns to 0.1 um
- Exist at high/low temps
- Formed in combustor

## Aerosols:

- Non-carbon based
- Reactive
- Acids and combustion fragments - H<sub>2</sub>SO<sub>4</sub>, HNO<sub>3</sub>, THC, etc.
- Smaller than particulates

# Particle Source

## Particulates:

- Source - combustion
- Control by leaner burning, lower pressure, high temperature, high combustion efficiency, staged (axial) burning
- Smoke meter only current measurement - inadequate

## Aerosols:

- Source - Engine hot section, combination of combustion and exhaust gas
- Control by removing sulfur from fuel; reducing NOx, high combustion efficiency - Other control measures?
- No validated technique to measure from engine exhaust.

# Particle Quantification Needs

## Particulates and Aerosols

- Particle size and size distribution
- Total mass
- Characterization - What are its constituents?
- Range .001 to 1 + microns
- Reactivity:
  - Climate: nucleation potential
  - Constituents (health and air quality)
    - Make-up
    - Mutagenic and carcinogenic effects
    - Long-term health effects



# Particle Concerns

- Climate change - high altitude cloud formation changing the albedo of the earth.
- Local air quality - acid rain, smog (airports)
- Health - breathing problems - ingestion of particles and retention in lungs
  - Mutagenicity and carcinogenicity of particles-long term effects.



We do not know what is in jet engine exhausts

# Regulatory Problem

- EPA regulates particle concentrations on a local (state and county) basis -2X severity in congress.
- A/C operations not currently regulated locally but on a federal basis.
- EPA, environmentalists, local government wants to bring A/C within regulations applicable to all other polluters ---- eg. California Control Board.
- We do not even know what exists in jet engine exhaust besides smoke number (S.N.)
  - S.N. measures large particles only (see FAA memo)
- EPA regulates particle concentrations on a local (state and county) basis - 2X severity in congress
  - Small particles of concern
  - No validated method of obtaining required particle data exists - University of Missouri/Rolla may come closest with MASS unit.

# Technical Considerations

## Data Bases

- AEDC Engine tests
- Williams Engine tests, LeRC
- F-100 Engine Tests, planned LeRC
- Flight measurements from AEAP
- Combustor Tests
  - LDI - LeRC, University of Missouri/Rolla
  - RQL - UTRC/University of Missouri/Rolla

## Conclusion

- Data Base inadequate for determining aviation impact
- Need to expand - weight to modern and future “cleaner” engines

# Reduction Strategies

## Particulate

- Uniform/Lean burning
- Increasing pressures and combustion inefficiency-increase levels
- Is LPP the ultimate low?
- Can be measured in combustor rigs and engines

## Aerosols

- Eliminate sulfur from fuel - big problems
- Reduce NOx
- Any other strategies? - unknown
- Could aerosol effects be minimized by inerting the compounds?
- Do not exist in combustor exhaust - exist downstream of engine exit nozzle
- Do precursors exist in combustor exhausts?
- Can we remove combustor exhaust heat to aerosol forming regimes?

# Technology Plan Continued

- Easy Environmental answer - eliminate sulfur from fuel
  - Do study to determine cost, infrastructure, supply (worldwide) storage impacts - airframe manufacturer
  - Do study/Exp. to determine impact of sulfur - free fuels on air craft fuel system, - engine manufacturer
  - self lubricating pump
  - How low is allowable
- Apply above to as many venues as possible to obtain industry data-base.
  - In-house - particle measures for all tests
  - AST, HSR, other contract results
  - Capitalize on any available engine tests.
  - Team with DOD in joint ventures to characterize particles
- Provide basis for a future A/C regulation



# Global Atmospheric Effects of Aviation



Report of the Proceedings of the Symposium



Virginia Beach, Virginia USA



15-19 April 1996

PNEU



UNEP

OMM



WMO

# ***Status of National Aviation Assessments***

---

- The national assessments also indicate that  $\text{NO}_x$  emissions are presently similar (i.e., equivalent radiative forcing) to  $\text{CO}_2$  in climate importance.
- Potential implementation of advanced  $\text{NO}_x$  reduction technology, along with the short atmospheric residence time for this pollutant, could decrease future concerns with this pollutant.
- However, the level of confidence in the global assessment of this species contribution to climate change is low; and uncertainty regarding the natural and human sources of  $\text{NO}_x$  in the upper troposphere and lower stratosphere is especially high.

# ***Status of National Aviation Assessments***

---

- Studies of the effects of aerosol and particulate have only recently begun, the level of confidence in the related assessment is very low, and does not yet provide even qualitative guidance.
- Uncertainty regarding natural and human sources of cloud nuclei is high, but estimates of radiative forcing from indirect effects (i.e., “cloudiness”) of aircraft aerosol and particulate emissions indicate the impact may be similar to that from CO<sub>2</sub> or even larger.



# FLYING OFF COURSE ENVIRONMENTAL IMPACTS OF AMERICA'S AIRPORTS



What our critics say -- National Resources Defense Council

"While the Clean Air Act Amendments of 1990 effectively targeted motor vehicles and industrial sources for emissions reductions, it left state and local officials essentially unable to control air pollution from an airport's planes"

"Airports are not regulated in the same way as other comparably large air pollution sources. Although aircraft engine prototypes have to meet certain emissions standards, neither airports nor airlines are held accountable for total ground level aircraft emissions".

"Although significant environmental impacts were common to most of the airports in our survey, the regulatory framework currently in place to address these impacts is inadequate. Because aviation is the fastest growing mode of transportation in the United States, these failings must be addressed."

"Recommendations -- Treat airport generated emissions in the same manner as emissions from other large sources and include them in state air pollution plans" ..... "Conduct further study and require additional reporting of toxic aircraft emissions"

ENVIRONMENTAL PROTECTION AGENCY

40 CFR Part 51

[FRL- ]

Interim Implementation Policy on New or Revised Ozone and  
Particulate Matter (PM) National Ambient Air Quality  
Standards (NAAQS)

AGENCY: Environmental Protection Agency (EPA).

ACTION: Notice of Proposed Policy (NPP).

SUMMARY: This notice is to propose a policy regarding interim implementation requirements for ozone and PM air pollution control during the time period following promulgation of new or revised NAAQS. Elsewhere in today's Federal Register, EPA is proposing these NAAQS. The policy as proposed is intended to ensure momentum is maintained by the States in the current program while moving toward developing their plans for implementing the new NAAQS. An explanation and structure of the Federal Advisory Committee Act (FACA) Subcommittee for Ozone, PM and Regional Haze Implementation Programs (Subcommittee) is provided under SUPPLEMENTARY INFORMATION.

DATES: Written comments on this proposal must be received by [60 days from publication of today's notice].

ADDRESSES: Comments. Comments on this proposal should be submitted (in duplicate if possible) to the Air and Radiation Docket and Information Center, 401 M Street, SW, Washington, DC 20460, Attention Docket Number A-95-38. Docket. The public docket for this action is available for public inspection and copying between 8:00 a.m. and 5:30

**DRAFT DOCUMENT**

**REGULATORY IMPACT ANALYSIS**

**FOR**

**PROPOSED**

**PARTICULATE MATTER**

**NATIONAL AMBIENT AIR QUALITY STANDARD**

**Prepared by:**

**Innovative Strategies and Economics Group  
Office of Air Quality Planning and Standards  
U.S. EPA  
Research Triangle Park, N.C.**

**December 1996**

SCIENCE  
RESEARCH  
DEVELOPMENT

**PREPRINT**

**EUROPEAN SCIENTIFIC ASSESSMENT OF  
THE ATMOSPHERIC EFFECTS OF AIRCRAFT EMISSIONS.**

**JULY 1997**

ENVIRONMENT AND  
CLIMATE PROGRAMME



## European Commission Report

**"The release by aircraft engines of solid particles or liquid aerosols in the atmosphere (sulphates, soot) Coupled to the release of water could affect the radiative balance in the vicinity of the tropopause. In addition to their direct radiative effect, and their role in cloud formation, these particles may enhance significantly the importance of heterogeneous chemistry and could lead to ozone depletion in the lower stratosphere."**

**Recent studies "indicate that the smoke number, and therefore the SAE method only reflects the number density of the relatively insignificant numbers of large particles, whole not accurately accounting for the total number of particles emitted."**

**"Results indicate that sea level static engine test measurements should not be used to represent the altitude particle emissions from an engine. While there are prediction equations for calculation of gaseous emissions at altitude conditions from sea level data, such relationships have not yet been established for particulates."**

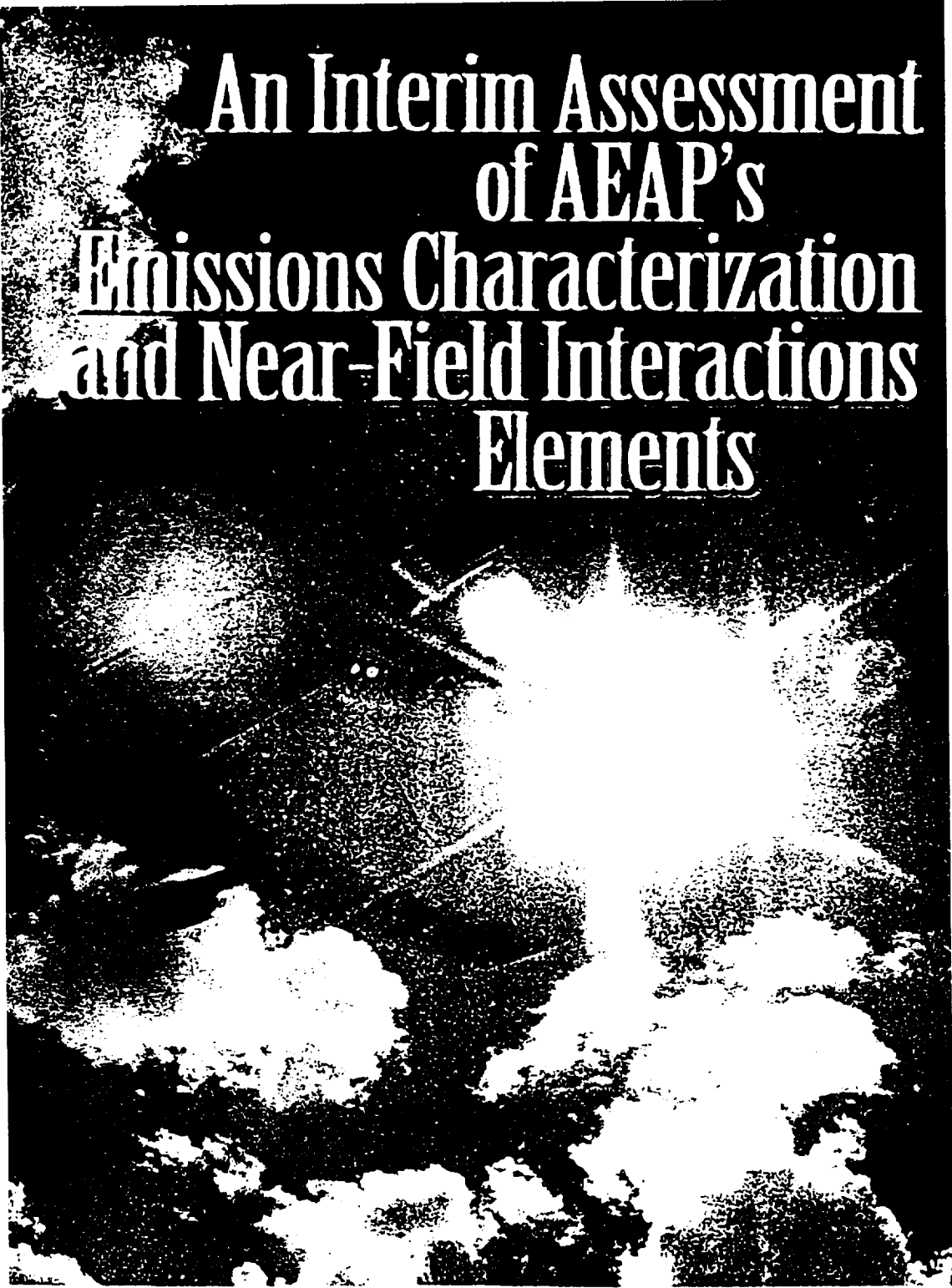

# An Interim Assessment of AEAP's Emissions Characterization and Near-Field Interactions Elements

**NATIONAL RESEARCH COUNCIL**

**PANEL ON ATMOSPHERIC EFFECTS OF AVIATION**

**ALBERT J. KAEHN, Jr. (Chair), Brigadier General, U.S. Air Force, retired**

**\*DONALD W. BAHR, retired (formerly with General Electric Aircraft Engines)**

**JACK G. CALVERT, National Center for Atmospheric Research, Boulder, Colorado**

**ANTONY D. CLARKE, University of Hawaii, Honolulu**

**\*WILLIAM E. COOPER, Michigan State University, East Lansing**

**DIETER H. EHHALT, Institut für Atmosphärische Chemie, Jülich, Germany**

**CLAIRE GRANIER, Université Paris, France; National Oceanic and Atmospheric Administration and Cooperative Institute for Research in Environmental Sciences, Boulder, Colorado**

**\*EDWARD GREITZER, Massachusetts Institute of Technology, Cambridge**

**JAMES R. HOLTON, University of Washington, Seattle**

**HAROLD S. JOHNSTON, University of California, Berkeley**

**\*KONRAD MAUERSBERGER, Max-Planck-Institut für Kernphysik, Heidelberg, Germany**

**MICHAEL OPPENHEIMER, Environmental Defense Fund, New York, New York**

**RUTH A. RECK, Argonne National Laboratory, Illinois**

**W. GEORGE N. SLINN, Cascade Scientific Research Corporation, Richland, Washington**

**KNUT H. STAMNES, University of Alaska, Fairbanks**

**YUK L. YUNG, California Institute of Technology, Pasadena**

***Staff***

**WILLIAM A. SPRIGG, Director**

**ELLEN F. RICE, Program Officer**

**DORIS BOUADJEMI, Administrative Assistant**



## NRC REVIEW

### RECOMMENDATIONS -- TRACE CHEMISTRY

- o Raise particulate & aerosol research needs to top priority level

- o Emphasize altitude engine testing

43

- o Develop & verify advanced diagnostic techniques for measurement of aerosols and particulates

- o Characterization required for both subsonic and supersonic aircraft --  
Concorde measurements cited for unexpectedly high levels

- o Focus on newer engines to extent possible - new entries in the fleet and demonstrator engines from AST & HSR program

## CONCLUSIONS

O PARTICULATE & AEROSOL EMITTANTS ARE A NEW SERIOUS CONCERN WHICH HAVE DRAWN THE ATTENTION OF ENVIRONMENTAL GROUPS, THE EPA, EUROPEAN AND U.S. SCIENTISTS AND THE NAS/NRC

O BOTH CLIMATOLOGICAL AND HEALTH CONCERNS HAVE BEEN RAISED

O AN INADEQUATE DATA BASE EXISTS REGARDING THESE EMITTANTS

- CURRENT SAE SMOKE NUMBER IS INADEQUATE FOR DETAILING CONSTITUENTS

O EXISTING DATA EMPHASIZES OLDER ENGINES AND AIRCRAFT -- NOT REPRESENTATIVE OF ADVANCED AND FUTURE FLEET

O VERIFIED ADVANCED INSTRUMENTATION AND DATA-TAKING TECHNIQUES REQUIRED

## STATEMENT OF PROBLEM: ENGINE AND NEAR-FIELD; AEROSOL AND PARTICULATE

R.C. Miake-Lye  
Aerodyne Research, Inc.  
Billerica, Massachusetts

**Motivation and context:** The primary objective of NASA's Atmospheric Effects of Aviation Project (AEAP) is to assess the global impact of emissions deposited in the atmosphere from commercial aviation operating at cruise altitudes. Historically, the global implications of aircraft emissions have not been the subject of legislative regulation as have near-airport impacts, so the measurements to quantify these high altitude emissions are not a standard part of engine certification and are generally not available. Thus, a significant component of AEAP is to characterize the cruise emissions from the commercial fleet.

In the first years of AEAP, planning and prioritizing of the species and measurement techniques were carried out [EETC Committee report] to establish the direction of the emissions characterization element of AEAP. The current status of the activity to date is that CO<sub>2</sub>, H<sub>2</sub>O, and NO<sub>x</sub> have been well characterized. These primary combustion products and the pollutant emissions that have been the focus of many global studies to date have been measured with multiple techniques [AEDC Report] and at multiple venues, including in-flight [Fahey et al, DLR's POLINAT, SUCCESS]. In addition to these gaseous emissions, non-volatile (soot) particle number densities and particle size data are now available for many engines [UMR references] and multiple measurement venues, as well.

From these efforts, primary emissions can be quantified with reasonable accuracy for the existing commercial fleet and projections for these emissions can be made for future technologies. On the other hand, modeling and in-flight measurements have raised questions about other emissions which have yet to be fully characterized. For NO<sub>x</sub> emissions, the conversion to non-NO<sub>x</sub> NO<sub>y</sub> (HONO, HNO<sub>3</sub>) has not been quantified. Based on chemical kinetics calculations, this conversion is expected to be modest and global modeling results suggest that, for such modest conversions, the global effects are predicted to be small.

A more uncertain situation holds for sulfur emissions. The degree of SO<sub>2</sub> oxidation to SO<sub>3</sub> and H<sub>2</sub>SO<sub>4</sub> also has not been quantified for many situations and has implications for aerosol formation as discussed below. Further, the state of emitted aerosols needs characterization beyond the number densities and size distributions to understand how emitted aerosol may affect contrail and cloud formation. More specifically, when, where, and how does soot become condensation nuclei (CN) capable of condensing water vapor? In order to fully understand how these questions affect the global atmosphere, chemical and physical processes that are occurring in the near-field of the airplane's wake and, indeed, within the engine itself need to be understood.

**Problem:** With the current level of engine emission characterization, *aerosol properties, aerosol precursor gases, and aerosol formation processes are not sufficiently well*

*understood to make a reliable global impact assessment.* Advances in our understanding are required in the following areas:

- SO<sub>3</sub>: Sulfur emission speciation; to understand SO<sub>2</sub> oxidation and aerosol formation
- Soot: Activation for condensation nucleation processes; coagulation with soot, sulfate aerosol, and ambient CN
- Radicals: Which are active in post-combustor sections of engine (rates and mechanisms)? Which are emitted at nozzle exit?
- HCs: Do unburned hydrocarbons have any role in aerosol formation?

**SO<sub>x</sub> Effects:** Modeling studies of the stratosphere (Weisenstein et al., 1996; Danilin et al., 1997) indicate that the chemical and physical state of sulfur emissions are important for understanding their global impact. When aircraft sulfur emissions are deposited in the atmosphere as many small sulfate aerosols, the additional surface area and associated heterogeneous reactions reduce the NO<sub>x</sub> induced ozone depletion. At the same time, ozone depletion is increased due to heterogeneous processing on sulfate aerosol that shifts Cl<sub>y</sub> and Br<sub>y</sub> to ClO and BrO, respectively, and shifts HO<sub>x</sub> to OH. The net effect of SO<sub>x</sub> emissions is a decrease in ozone which may be more important than that due to NO<sub>x</sub> emissions alone.

Recently measurements have been made in the troposphere (SUCCESS campaign, GRL 1997 special issue, POLINAT). Volatile (H<sub>2</sub>SO<sub>4</sub>) aerosols are the most numerous condensation nuclei close to the airplane, however their connection to contrail and cloud formation processes are still very uncertain. In what way do these volatile aerosol emission interact with soot and other (such as entrained ambient) particulates and what are the properties of the aircraft particulates as they are left for atmospheric dispersal?

**SO<sub>x</sub> Puzzle:** Modeling and limited engine experimental data suggest SO<sub>x</sub> is emitted mostly as SO<sub>2</sub>. However, in-flight experiments indicate >10% has condensed as H<sub>2</sub>SO<sub>4</sub> [Fahey et al., 1995] within 100m of emission [Anderson et al., 1997; Miake-Lye et al., 1997]. Could the model results and few measurements be missing SO<sub>x</sub> emissions leaving the engine as SO<sub>3</sub>/ H<sub>2</sub>SO<sub>4</sub>? If so, what new kinetic rates or mechanisms are needed to explain this additional oxidation? On the other hand, if the models and measurements are correct that most of the sulfur emissions are SO<sub>2</sub>, how is SO<sub>2</sub> being oxidized immediately after emission to account for the numerous volatile aerosol? What non-linear and/or heterogeneous mechanism can be identified that could oxidize the SO<sub>2</sub> fast enough?

**Soot Emissions:** What does aviation contribute to atmospheric background of black carbon aerosol? Measurements in the upper troposphere have sampled soot emissions that have been attributed to aircraft exhaust, but how do the numerous 20-40 nm particles that are measured at the engine exhaust [Hagen presentation, Lilienfeld presentation, UMR references] end up contributing to the larger sized particle in the ambient background? Indeed, what is the particle size distribution due to aircraft exhaust that is deposited in the atmosphere? Perhaps most important, does aviation soot have unique contrail or cloud formation properties and what makes soot capable of condensing water?

The activation of soot by trace species in the exhaust has been suggested as one means of their chemical activation. Which species are responsible for this activation?  $\text{SO}_x$  has been proposed as a likely candidate but are  $\text{SO}_x$  emissions sufficient and are they necessary? Does activation occur during soot formation (which occurs in the combustor), at high T (in the combustor and/or turbine), or at low T (chemical activation, coagulation after emission)?

**Intra-Engine Processes:** What oxidation of important pollutant emissions ( $\text{NO}_x$ ,  $\text{SO}_x$ ) occurs inside the engine? In order to understand these processes, flowfield/chemistry coupling effects need to be accounted for [Waitz presentation, Lukachko et al., 1997]. The temperatures and pressures encountered in the post-combustor engine hot sections span a range between combustion conditions and atmospheric conditions where existing experimental results are lacking. Thus there are limitations of the applicability of existing rates for mechanisms which are included in models and it is not clear whether a complete kinetic mechanisms has been assembled for this intermediate regime.

Central to understanding the evolution of emissions within the engine is to identify which radicals drive intra-engine oxidation. When intra-engine processes are sufficiently well understood, both the emissions and the remaining oxidative radicals, available for subsequent reactions in the external exhaust flow, can be quantified. Such results will provide a more complete exhaust characterization for calculated estimates of continued exhaust evolution by near-field models and for eventual deposition in the global atmosphere. In addition, a reliable intra-engine model will provide a predictive capability for engines for which a full set of emissions measurements do not exist, including new technology engines which may be still under development.

**Requirements:** The full characterization of aircraft emissions for use in a global assessment will require several additional types of data. A better understanding of  $\text{SO}_x$ ,  $\text{NO}_y$ , and  $\text{HO}_x$  emissions is necessary. In particular, the speciation of  $\text{SO}_x$  at emission is least understood, so initial measurements here are most important. The uncertainties in our understanding of  $\text{SO}_x$  emissions suggest that  $\text{NO}_y$  speciation, in particular emissions of HONO and  $\text{HNO}_3$ , has not been determined quantitatively either. Thus, measurements of  $\text{SO}_x$ ,  $\text{NO}_y$ , and  $\text{HO}_x$  at the engine exit would constrain our uncertainties in gas phase kinetics in several dimensions. Such results, in concert with measurements of radical levels (O, OH, ...) at the high pressure turbine entrance, could be used directly in developing a better, more complete mechanism for post-combustor hot sections. Beyond the gaseous emissions, our understanding of soot activation is incomplete, and basic laboratory data combined with relevant engine test results are needed to determine the properties of aircraft particulate emissions so that they too can be included in a global assessment. Finally, a predictive capability is needed to extend engine measurement results to related cycles and technology that is being considered for implementation in the future, as global assessments attempt to predict the future state of the atmosphere.

# Motivation and context

---

Objective: Assess global impact of aviation emissions at altitude.

→ Characterize cruise emissions

Status: CO<sub>2</sub>, H<sub>2</sub>O, and NO<sub>x</sub> have been well characterized.

Measured with multiple techniques at multiple venues, including in-flight.

Non-volatile (soot) particle number densities, particle size data available for many engines, multiple venues.

- NO<sub>x</sub> conversion to non-NO<sub>x</sub> NO<sub>y</sub> (HONO, HNO<sub>3</sub>)?  
Conversion modest, global effects small.
- SO<sub>2</sub> oxidation to SO<sub>3</sub>, H<sub>2</sub>SO<sub>4</sub>?
- When, where, how does soot become condensation nuclei (CN)?
- Raises near-field (and engine) chemistry issues.

# Problem

---

Cannot quantify aerosol properties or precursors and aerosol formation sufficiently to make global impact assessment.

SO<sub>3</sub>: Speciation—to understand SO<sub>2</sub> oxidation, aerosol formation

Soot: Activation for condensation nucleation processes, coagulation with soot, sulfate aerosol, ambient CN

Radicals: Which are active in post-combustor sections of engine (rates and mechanisms)? Which are emitted at nozzle exit?

HCs: Any role in aerosol formation?

# SO<sub>x</sub> Effects

---

Stratosphere (Weisenstein et al., 1996; Danilin et al., 1997)

- ◆ Sulfate aerosol reduces NO<sub>x</sub> effect on ozone depletion.
- ◆ Sulfate aerosol shifts Cl<sub>y</sub>, Br<sub>y</sub> to ClO, BrO; HO<sub>x</sub> to OH.
- ◆ Net effect: SO<sub>x</sub> emissions may be more important than NO<sub>x</sub>.

Troposphere (SUCCESS campaign, GRL 1997 special issue)

- ◆ Volatile (H<sub>2</sub>SO<sub>4</sub>) aerosol are dominant close to airplane
- ◆ Connection to contrail and cloud formation process very uncertain.

Interaction with soot and other particulates?



# SO<sub>x</sub> Puzzle

---

Modeling and limited engine experimental data suggest SO<sub>x</sub> emitted as SO<sub>2</sub>.

In-flight experiments indicate >10% condensed as H<sub>2</sub>SO<sub>4</sub> (Fahey et al., 1995) within 100m of emission (Anderson et al., 1997; Miake-Lye et al., 1997).

- ◆ Leaving engine as SO<sub>3</sub>/H<sub>2</sub>SO<sub>4</sub>? What new kinetic rates or mechanisms are needed to explain?
- or
- ◆ Oxidizing immediately after emission? What (non-linear, heterogeneous?) mechanism can oxidize fast enough?

# Soot Emissions

---

What does aviation contribute to atmospheric background?

- ◆ What is particle size distribution deposited in the atmosphere?
- ◆ Does aviation soot have unique contrail or cloud formation properties?

52

What makes soot capable of condensing water?

- ◆ Chemical activation? By what? ( $\text{SO}_x$  sufficient? necessary?)
- ◆ Does activation occur during soot formation (combustor), at high T (in combustor/turbine), or at low T (chemical activation, coagulation)?

# Intra-Engine Processes

---

- ◆ What oxidation ( $\text{SO}_x$ ,  $\text{NO}_x$ ) occurs inside engine?
  - Flowfield/chemistry coupling effects.
  - Limitations of existing rates (mechanisms).
  - Which radicals drive intra-engine oxidation? Which are emitted into exhaust for external reactions
- ◆ Provide complete calculated estimates for near-field models.
- ◆ Develop predictive capability for unmeasured engines, new technology.

# Requirements

---

- ◆  $\text{SO}_x$  speciation;  $\text{NO}_x$  + HONO,  $\text{HNO}_3$ ; OH at engine exit.
- ◆ Better, more complete mechanism for post-combustor hot sections.
- ◆ Radical levels (O, OH, ...) at HP turbine entrance, nozzle exit.
- ◆ Soot activation, (basic laboratory data, engine test results).
- ◆ Predictive capability to extend results to related cycles, technology.

## POTENTIAL CLIMATE IMPACTS OF ENGINE PARTICLE EMISSIONS

S. Randy Kawa  
NASA Goddard Space Flight Center  
Greenbelt, Maryland

Solid (soot) and liquid (presumed sulfate) particle emissions from aircraft engines may have serious impacts on the atmosphere. While the direct radiative impact of these particles is expected to be small relative to those from natural sources (Atmospheric Effects of Subsonic Aircraft: Interim Assessment of the Advanced Subsonic Technology Program, NASA Ref. Pub. 1400, 1997), their indirect effects on atmospheric chemistry and cloud formation may have a significant impact. The potential impacts of primary concern are the increase of sulfate surface area and accelerated heterogeneous chemical reactions, and the potential for either modified soot or sulfate particles to serve as cloud nuclei which would change the frequency or radiative characteristics of clouds. Volatile (sulfate) particle concentrations measured behind the Concorde aircraft in flight in the stratosphere were much higher than expected from near-field model calculations of particle formation and growth. Global model calculations constrained by these data calculate a greater level of stratospheric ozone depletion from the proposed HSCT fleet than those without particle emission. Soot particles have also been proposed as important in heterogeneous chemistry but this remains to be substantiated. Aircraft volatile particle production in the troposphere has been shown by measurements to depend strongly on fuel sulfur content. Sulfate particles of sufficient size are known to provide a good nucleating surface for cloud growth. Although pure carbon soot is hydrophobic, the solid particle surface may incorporate more suitable nucleating sites. The non-volatile (soot) particles also tend to occupy the large end of aircraft particle size spectra. Quantitative connection between aircraft particle emissions and cloud modification has not been established yet, however, even small changes in cloud amount or properties could have a significant effect on the radiative balance of the atmosphere.

<http://hyperion.gsfc.nasa.gov/AEAP/AEAP.html>

# AEAP Mission

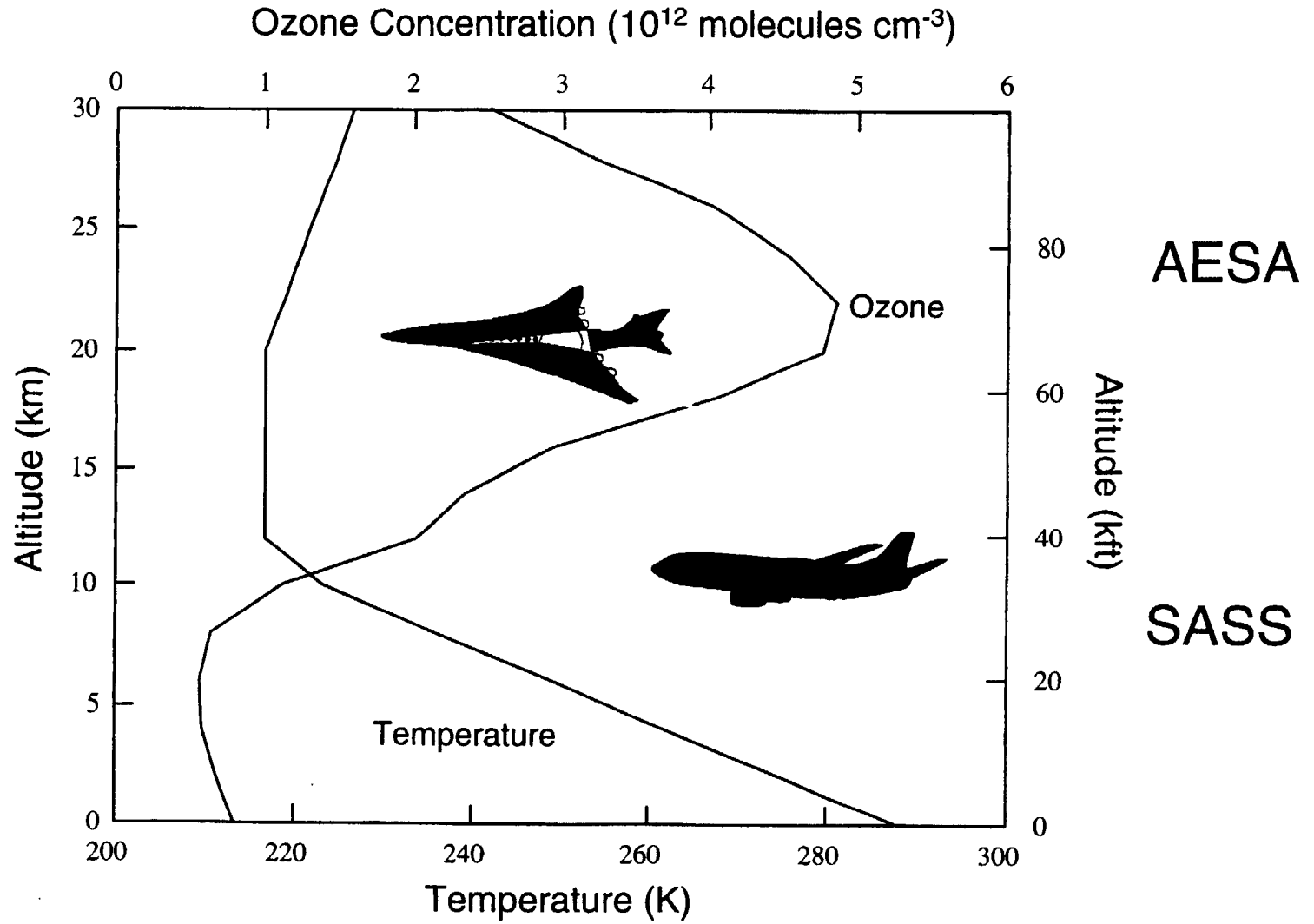

# CLIMATE EFFECTS OF EMISSIONS

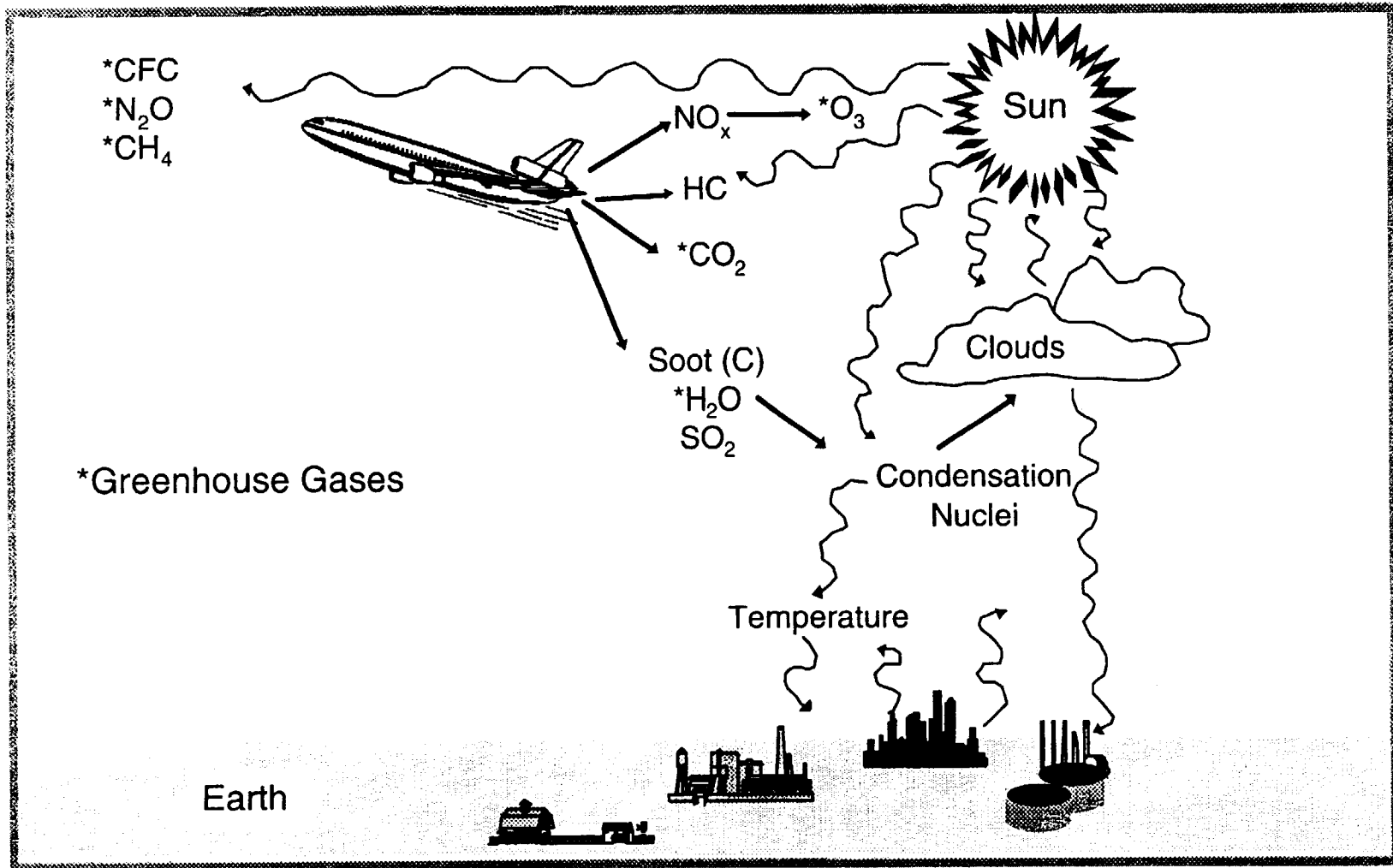

## SASS Assessment (Friedl et al., 1997)

Emittant	Impact	Impact Estimate (Global Ave.)	Uncertainty
NO <sub>x</sub>	O <sub>3</sub> Column	+ 0.1 % (+0.3% ave., over 30°-60°N)	±0.5%, NO <sub>x</sub> sources poorly quantified
	Direct Radiative Forcing	+0.001 W m <sup>-2</sup>	small
	Indirect Rad. Forcing	+ 0.01 W m <sup>-2</sup>	±0.05 W m <sup>-2</sup> , NO <sub>x</sub> sources poorly quantified
CO <sub>2</sub>	O <sub>3</sub> Column	negligible	small
	Direct Radiative Forcing	+ 0.0003 W m <sup>-2</sup> (+0.0067 W m <sup>-2</sup> over last 30 years)	±0.0001 W m <sup>-2</sup> , mainly due to model uncertainties
Hydrocarbons	O <sub>3</sub> Column	small	small
	Direct Radiative Forcing	negligible	small
	Indirect Rad. Forcing	negligible	small
CO	O <sub>3</sub> Column	small	small
	Direct Radiative Forcing	negligible	small
	Indirect Rad. Forcing	negligible	small



## SASS Assessment (cont.)

Emittant	Impact	Impact Estimate (Global Ave.)	Uncertainty
H <sub>2</sub> O	O <sub>3</sub> Column	small	large, depends on PSC details
	Direct Radiative Forcing	significant, sign uncertain	large, radiative transfer properties of contrails poorly known
	Indirect Rad. Forcing	potentially significant	moderate, depends on involvement in PSC/O <sub>3</sub> process and/or in plume processes that result in CCN and IN
Sulfur	O <sub>3</sub> Column	small	large, sources inadequately defined, size distribution poorly known
	Direct Radiative Forcing	+0.0001 W m <sup>-2</sup>	moderate, sources inadequately defined, size distribution poorly known
	Indirect Rad. Forcing	potentially significant	large, interaction with aircraft soot and role as CCN/IN poorly defined
Soot	O <sub>3</sub> Column	small	small
	Direct Radiative Forcing	+ 0.003 W m <sup>-2</sup>	moderate, size distribution and single particle albedo uncertain
	Indirect Rad. Forcing	unknown	large, depends on # that are coated with sulfur and act as CCN or IN

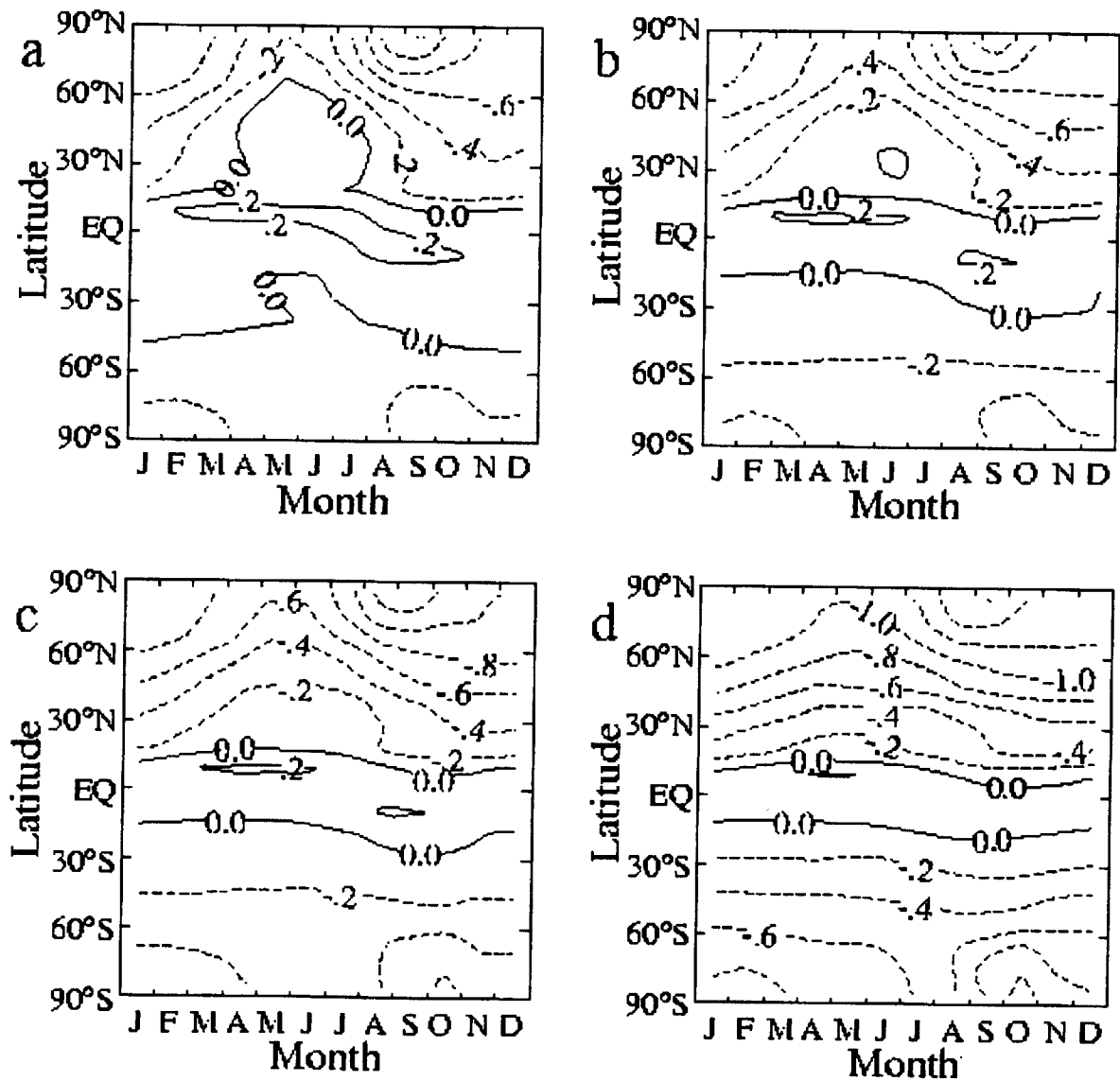

Percent change in column ozone due to emissions from HSCT Aircraft with  $EI(\text{NO}_x)=5$ . Panel (a) Shows results with no  $\text{SO}_2$  emission. Panels (b)-(d) include  $\text{SO}_2$  emission as (b) 100% gas, (c) 90% gas and 10% particles, and (d) 100% particles [Weisenstein et al., GRL, 1996].

UMR MOBILE AEROSOL SAMPLING FACILITY AND SMOKE METER

D.E. Hagen, P.D. Whitefield, J. Paladino, and H.V. Lilenfeld  
University of Missouri—Rolla  
Rolla, Missouri

## PARTICULATE PROPERTIES

Concentration

Size distribution (Area, Volume)

Emission Index

Volatility

Hydration

Morphology

Composition

## CONDITION VARIABLES

Altitude

T3

P3

Fuel composition

## RECENT CAMPAIGNS

### AIRBORNE SAMPLING

NCAR Sabreliner  
DLR plume chasing  
POLINAT  
NASA Project SUCCESS  
AF RISO

### GROUND TEST SAMPLING

McDD Hush House  
Pratt & Whitney  
AEDC (altitude chamber)  
ATTAS ground test  
Concorde engine test  
NASA Langley (B737, B757, T38)  
NASA Lewis  
AFNG F15 JP8+100

### OTHER

AF Phillips Laboratory  
WPAFB Fuel formulation/Ptl formation

# UAR Mobile Aerosol Sampling System

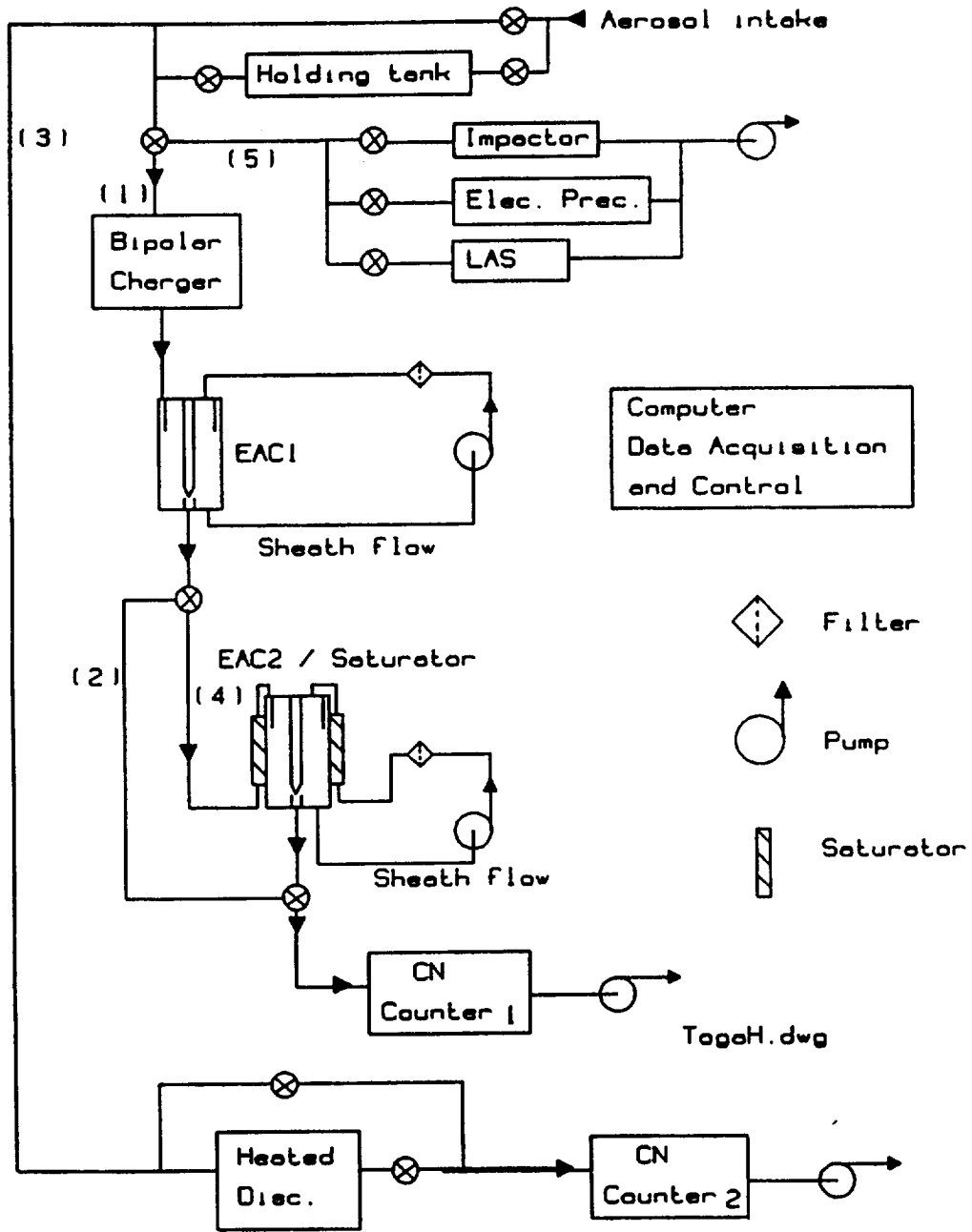

Aerosol size distr, 97201 gb9&a  
ANG, F-15, F100-100

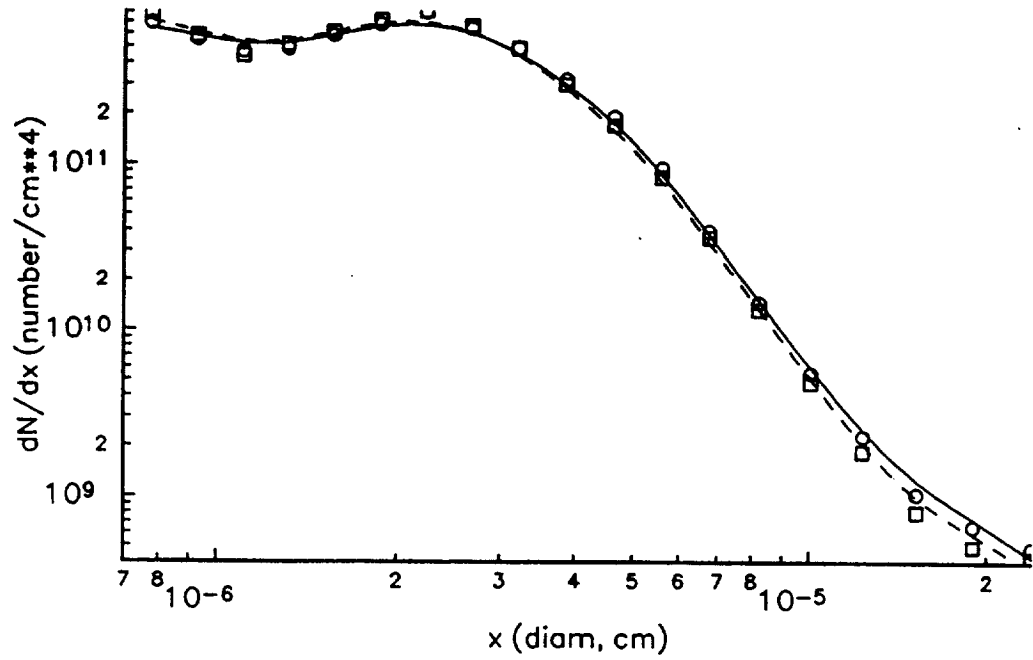

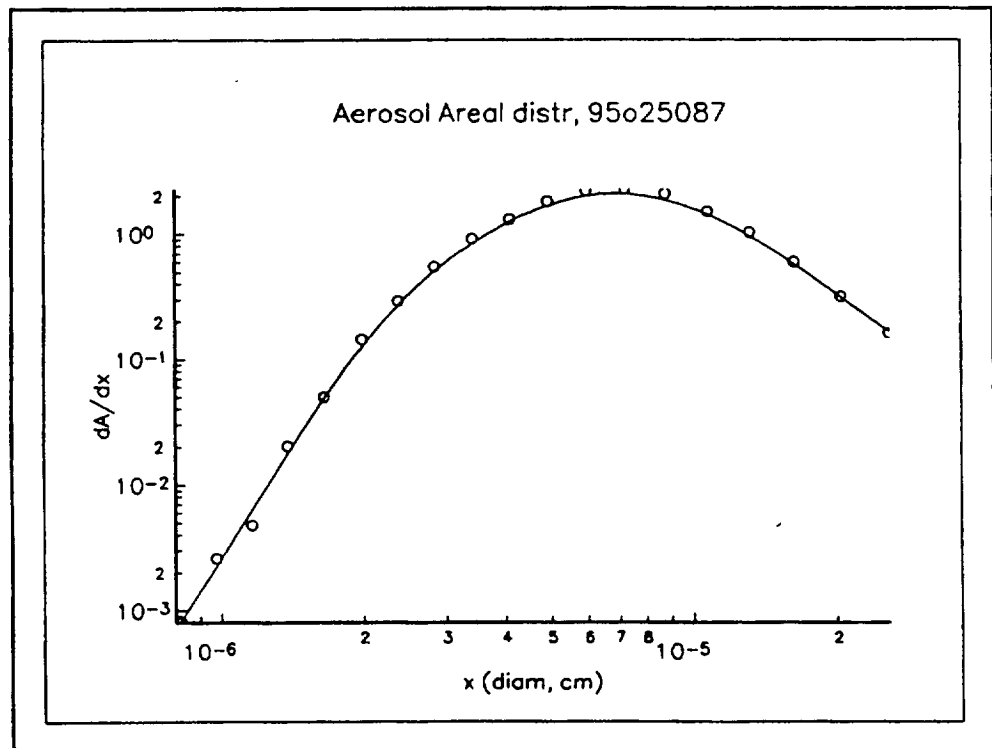
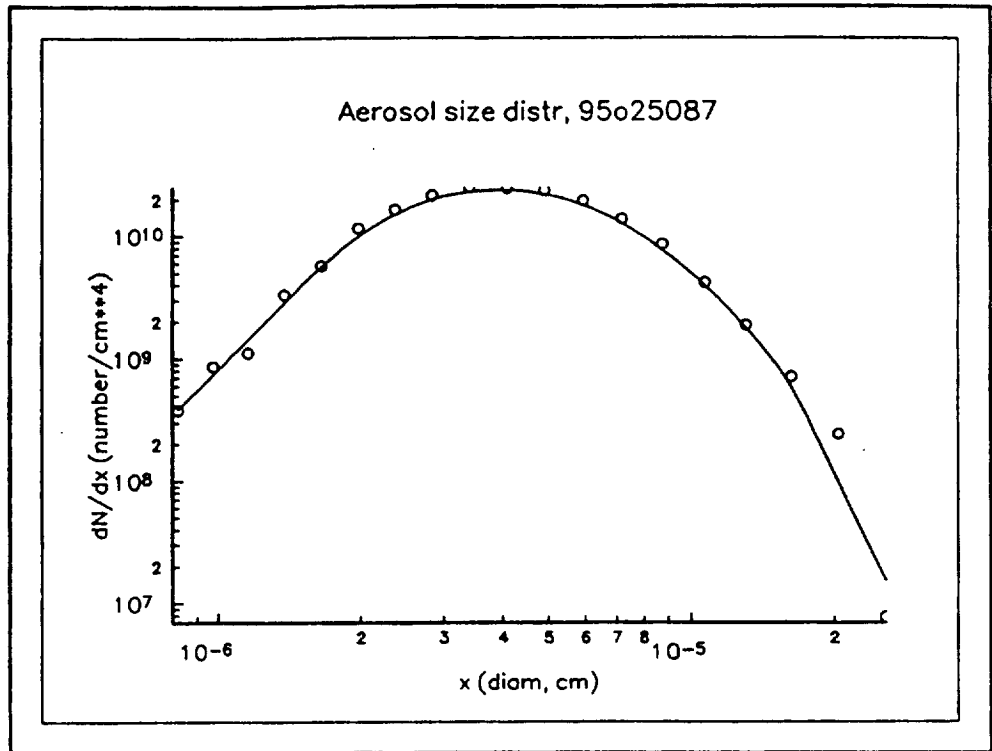

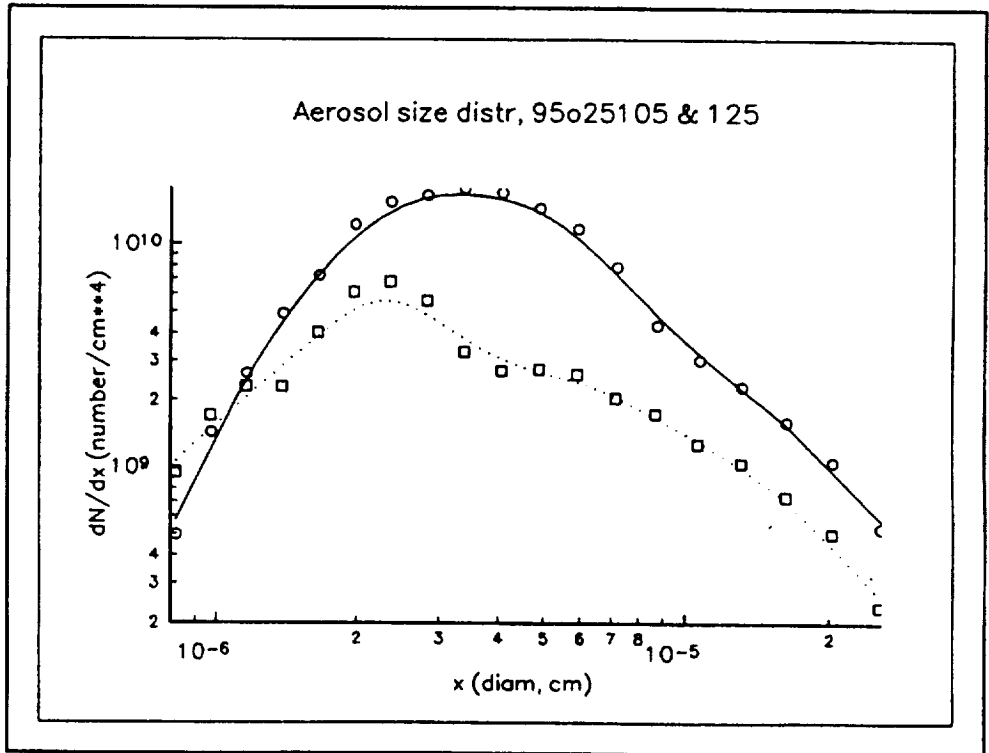
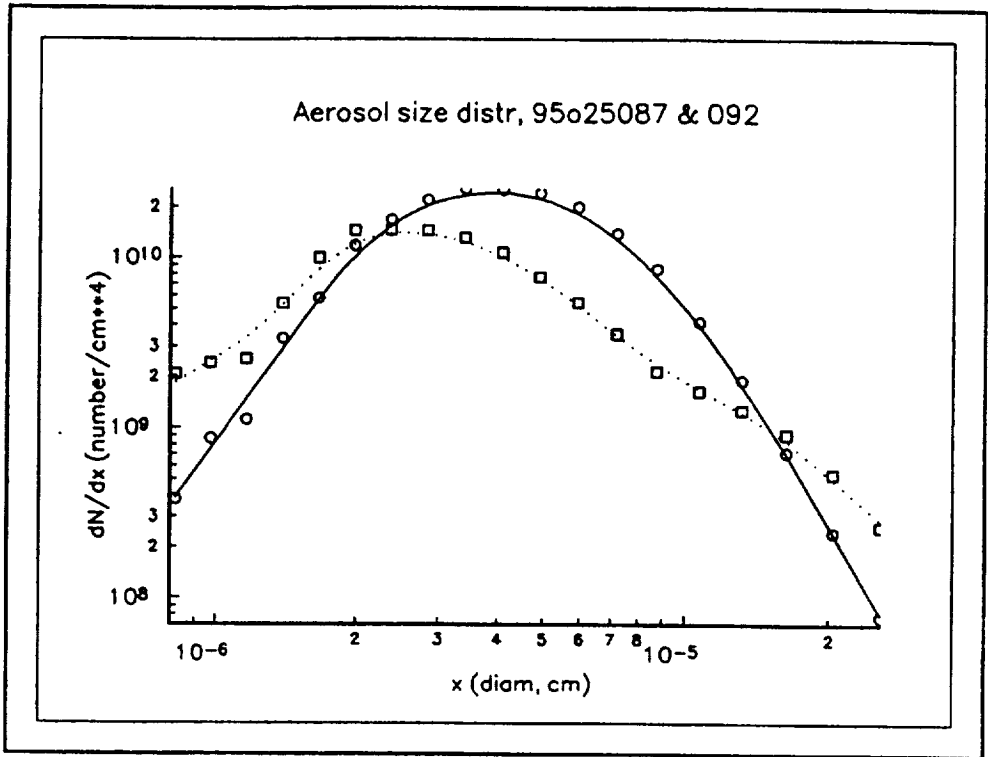



G72501.grf

Aerosol size distr,  
MO\_ANG, AEDC, NJ\_ANG

- △ GC9
- ◇ 156
- 009
- 010
- △ 011

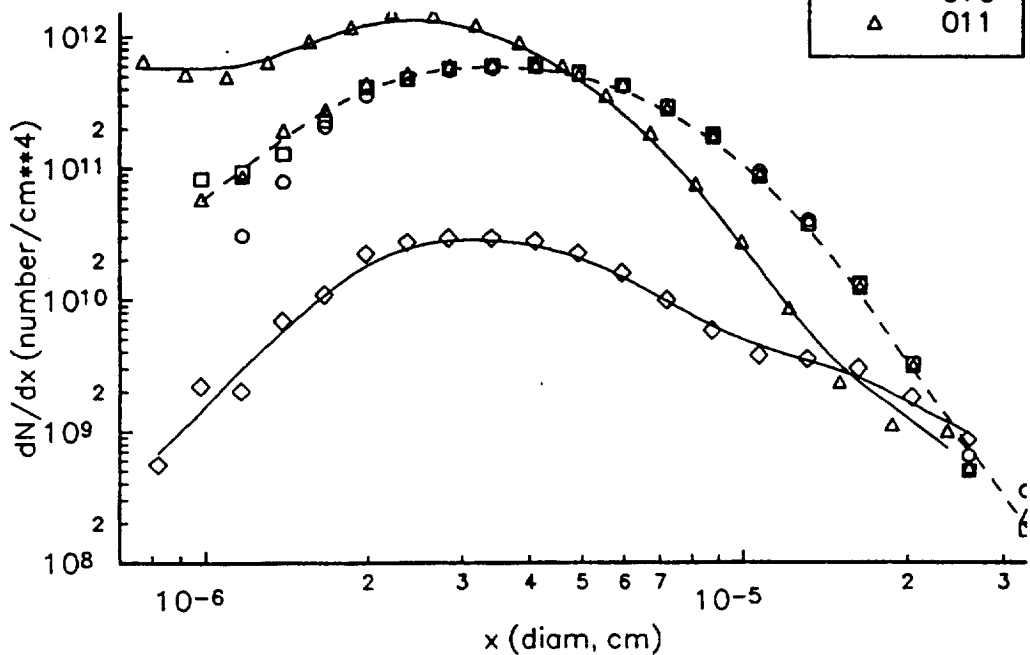

MO\_ANG, F100-100, gc9, 76%  
AEDC run 156, T3=733K, Alt=3.1 km (SLS), Time=14:57:00  
MO\_ANG, F100-220, 009,010,011, 80%

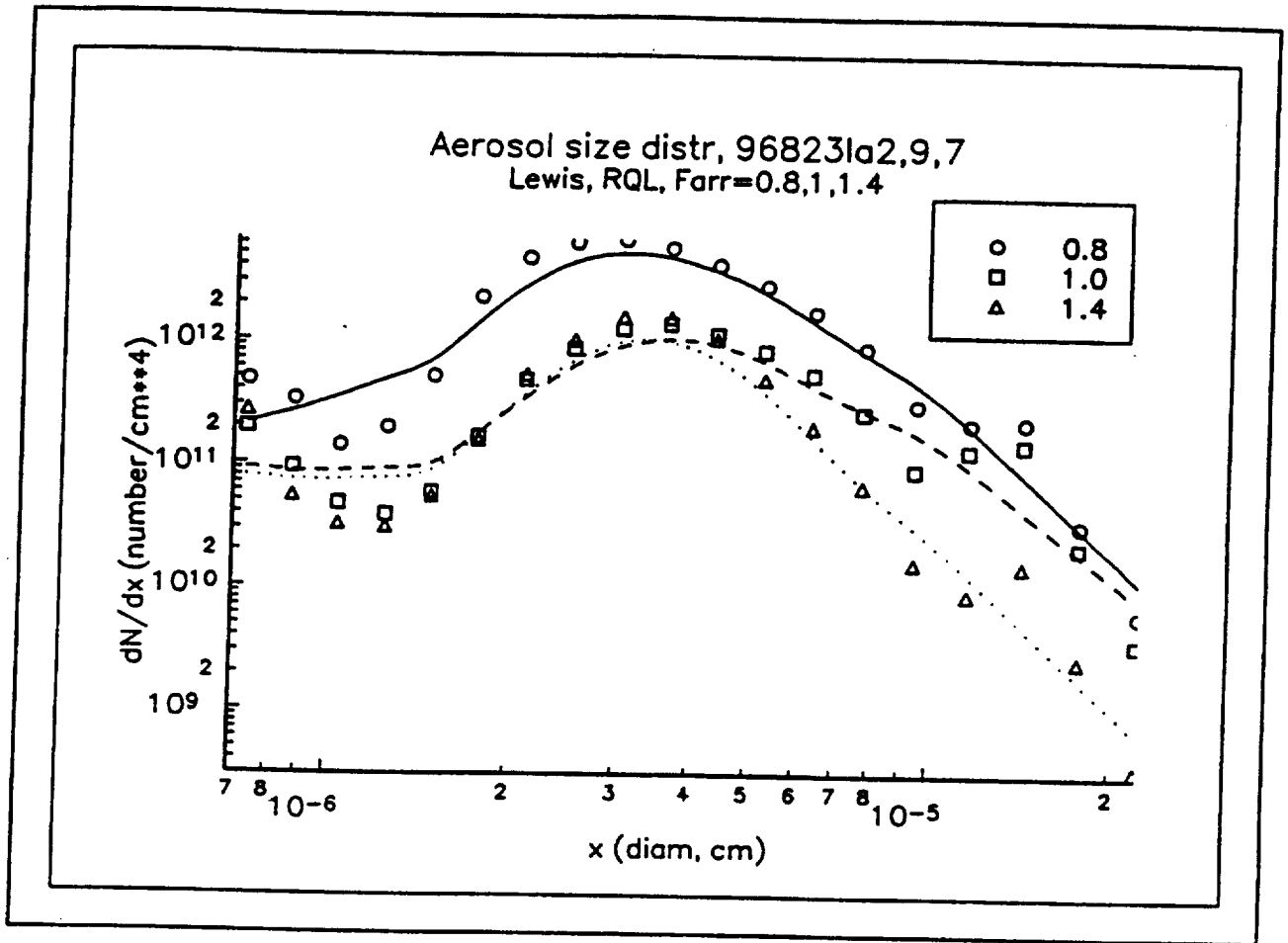

# EI (TOTAL) vs DISTANCE, 5-3-96 SUCCESS

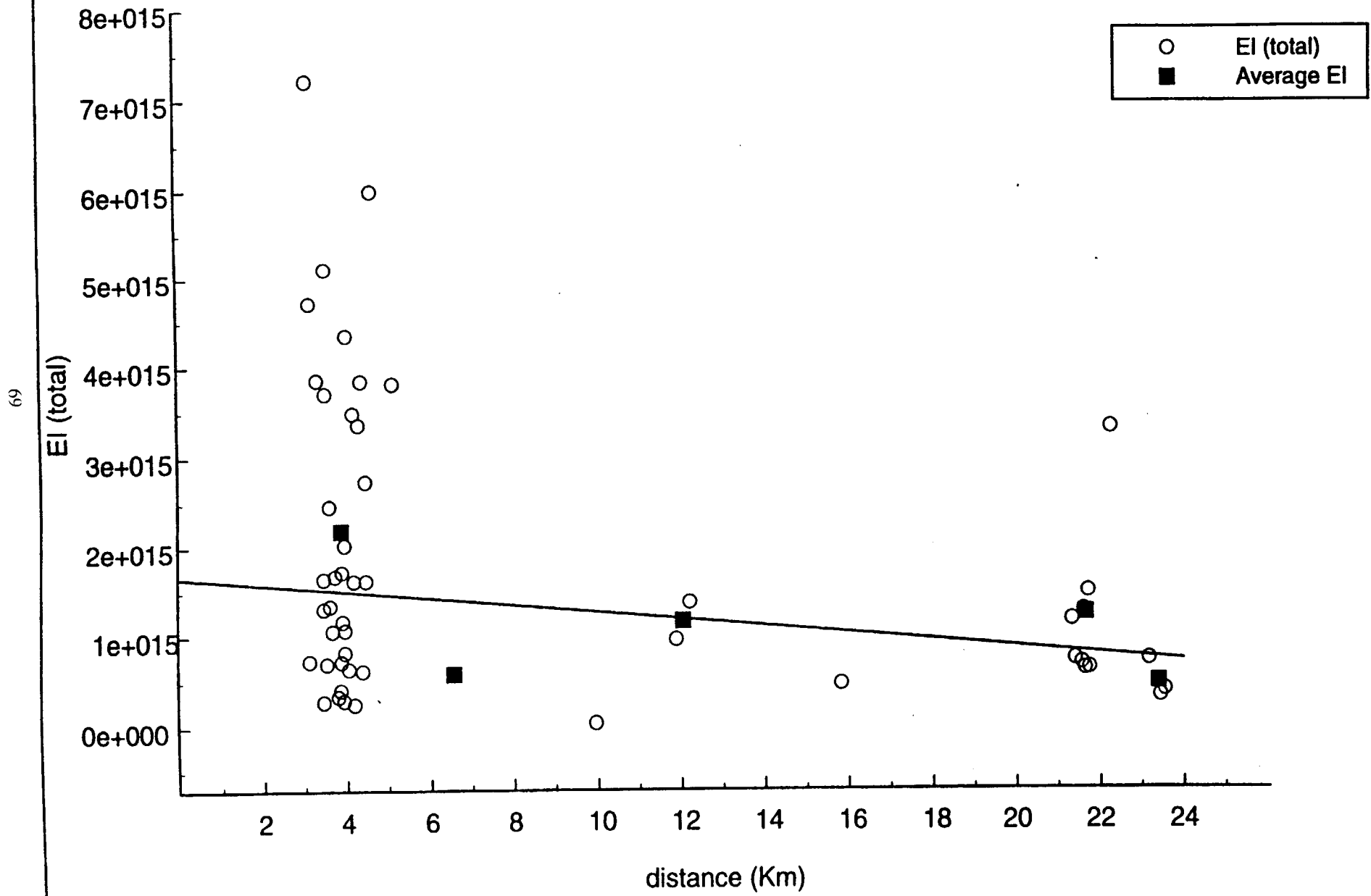

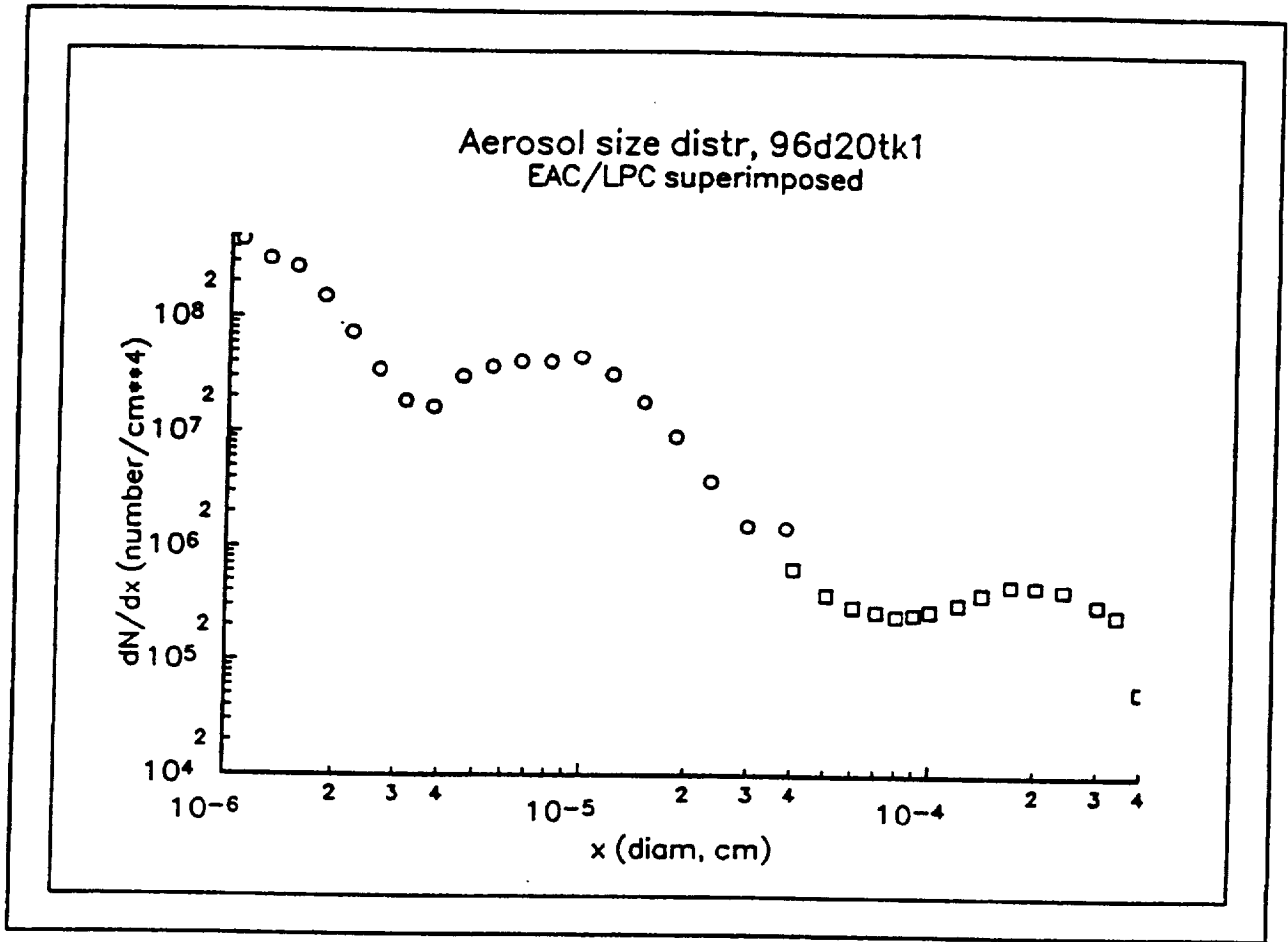

# SMOKE METER

The Smoke Meter attempts to measure the particulate emission in the jet engine exhaust flow.

Several known volumes of exhaust are passed through a filter. Any change in the observed optical reflectance of the filter can be correlated to the quantity of particulate matter in the exhaust.

The Smoke Number derived from the optical reflectance and flow rate information is the industry standard for particulate emission in jet exhaust.

## Questions:

1. Does the filter collect all particles, including those of atmospherically significant diameters ( $< 100\text{nm}$ ) ?
2. If so, does the derived Smoke Number accurately represent the presence of the atmospherically significant particles?
3. Can any correlations be drawn between Smoke Number data and the data acquired using the MASS methodology?

# 737 FLIGHT ENCOUNTERS

## SUCCESS 3 May 1996

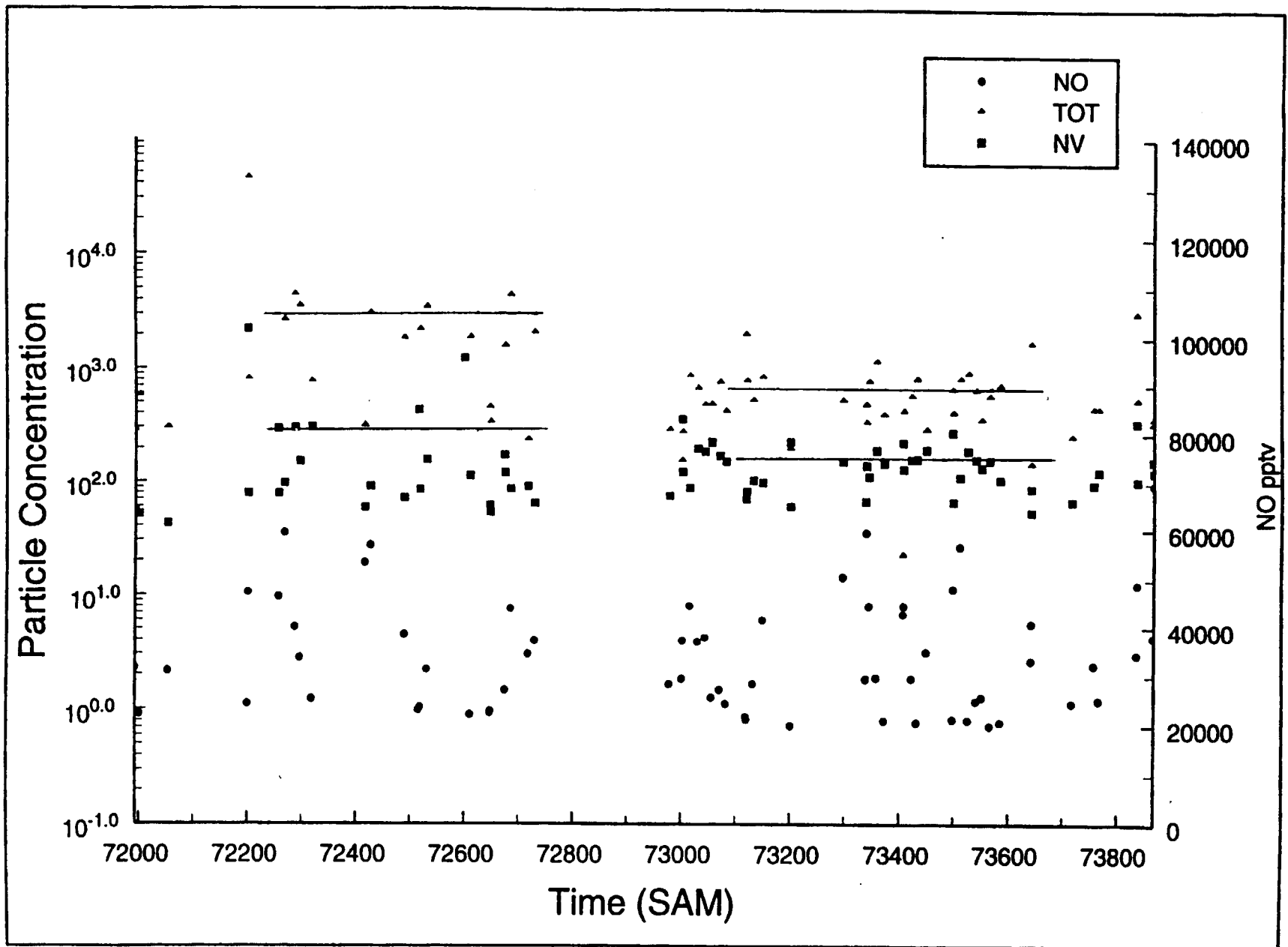

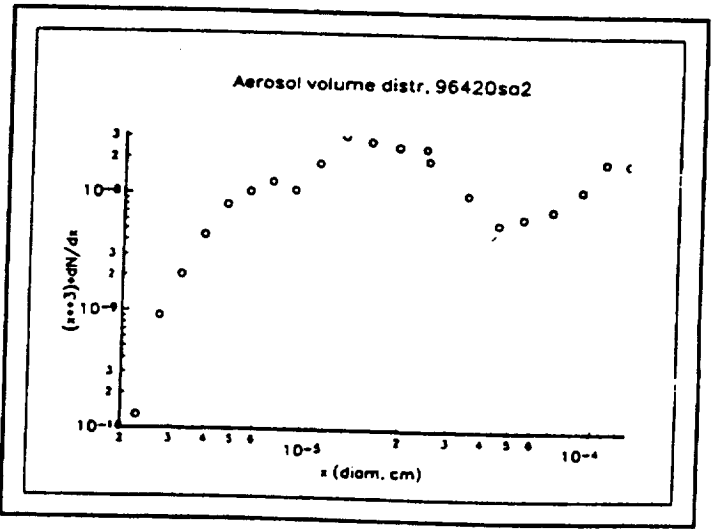
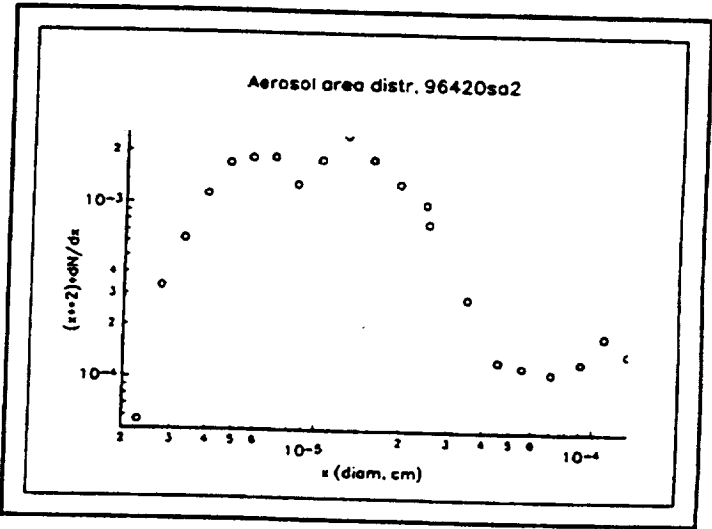
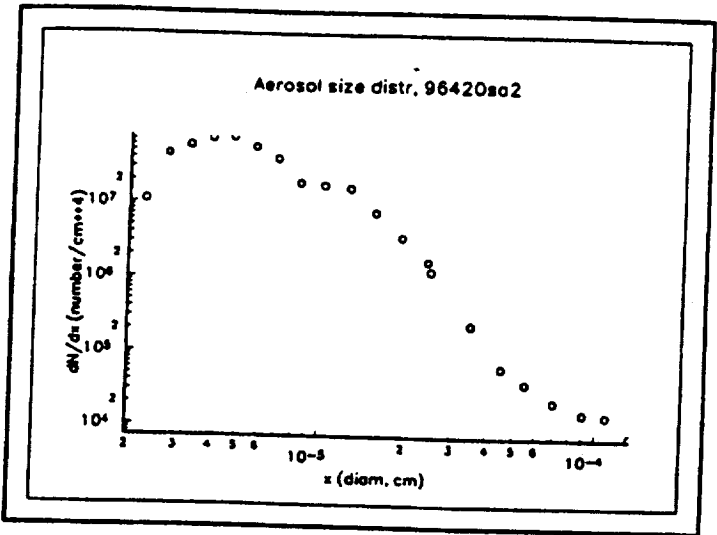



# Millipore Fine Particle Transmission Studies

Particle Diameter	%Transmission
10nm	0.868
50nm	0.004
100nm	0.002
150nm	0.000
200nm	0.000

# Smoke Number Analysis

## Total Smoke Number

Sample Time(s)Smoke Index

159.22

2513.35

5018.15

10030.33

Smoke Number $\Longrightarrow$ 14.68

## Impactor Smoke Number

Sample Time(s)Smoke Index

152.72

259.22

5012.29

10014.88

Smoke Number $\Longrightarrow$ 8.34

<b>Particle Size (nm)</b>	<b>Number Collected</b>	<b>Smoke Index</b>	<b>Extrapolated Smoke Number</b>	<b>Total Aerosol Surface Area (cm<sup>2</sup>)</b>	<b>Total Aerosol Mass (g)</b>
53	1E+09	0	0	8.8e-6	7.8e-8
78	1E+09	2.27	0	1.9e-5	2.5e-7
116	1E+08	20.57	0	4.9e-6	9.6e-8
143	1E+08	24.14	2.64	7.5e-6	1.8e-7
223	1E+08	57.34	40.38	1.8e-5	6.8e-7

# CONCLUSIONS

1. The Smoke Meter filter does collect all particles.
2. However, atmospherically significant particles, the most numerous in typical jet engine exhaust, do not contribute to the Smoke Number in a measurable fashion.
3. The Smoke Number is largely a result of the few large diameter particles emitted from jet engines.
4. In the recently reported AEDC test, an altitude chamber test of an advanced current engine, the measured Smoke Numbers were 0 for all operating conditions; whereas the mean emission index for atmospherically significant particles was measured to be  $1E13$  particles/kg fuel.
5. Recent studies have demonstrated a relationship between Smoke Number and particulate emission index for older engine technologies. ( Representative of the current subsonic commercial fleet. )

Test/date /sponsor	Meas Suite	Source	Major Results & Conclusions Reporting Status
MDC GE404 Mar 92 MDAE	TCN/SD/HYD	HH/F18	proof of principle studies log normal distribution peak dia. <100nm typ.[CN]= $10^5 - 10^7 \text{ cm}^{-3}$  AIAA 95-0111 Reno Jan. 1995
UTRC Aug '94 NASA-AEA	TCN/SD/HYD	Early RQL res rig	log normal distribution peak dia. <100nm typ.[part] > $10^7 \text{ cm}^{-3}$ SMF - negligible  NASA-AEA Workshop Virginia Beach 1995.
POLINAT 1 Nov '94 NASA-AEA DLR UMR	TCN/SD/HYD	Multi- FLIGHT	Aircraft/Engines characterized in flight: B747 - CF6-80C2B1F B747 - JT9D-7A (3 NFS) B747 - CF6-50E2 (2 NFS) B747 - JT9D-7J B747 - CF1-50E2 DC10 - CF6-50C EA34 - CFM56-5C2  EI(CN)= $10^{14}-10^{16} / \text{kg fuel}$ Large volatile component Junge type distribution SMF decreases with plume age Direct evidence of GTPC during plume propagation
POLINAT 1 Jun '95 NASA-AEA DLR UMR	TCN/NVCN/SD /HYD	Multi- FLIGHT	Detailed results and conclusions given in: European Commission Report - EUR 16978 Pollution from Aircraft Emissions in the North Atlantic Flight Corridor (POLINAT) ISBN 92-827-8569-6 & associated publications

DLR Sulf2 Jul '95 UMR	TCN/NVCN/SD /HYD	GT ATTAS*	Particulate concentrations very high, increase with increasing fuel sulfur content. Size distributions demonstrate multi-modality but relative shape independent of fuel sulfur
Concorde Aug '95 UMR	TCN/NVCN/SD /HYD	GT Olympus	Largest EI(CN) measured to date $10^{17}$ - $10^{19}$ /kg fuel Junge type distributions, huge volatile component. Proc. of the Int. Coll. on the Impact of Aircraft Emissions Upon the Atmosphere, vol I pp119-124 Paris October 1996
AEDC Oct '95 NASA-AEA	TCN/NVCN/SD	ASC AdvCCT	<p>Mean EI(CN) calculated from all measurements is <math>2.2 \times 10^{13}</math>, associated mean mass-based EI(soot) is 0.012. No strong correlation between EI(CN) and thrust, alt or T3 and P3. Appears to be a correlation between combustion efficiency and EI(CN) observed in the ground idle data points, where elevated EI(CN), CO and UHC are recorded. EI(CN) measured are small compared with those measured for commercial fleet. Correlates well with SN = 0 reported in this study. Typ.SD's log-normal and peak in the vicinity of 20-40 nm diameter. The volatile component of the aerosol is measured to be small and in most cases negligible.</p> <p><b>Experimental Characterization of Gas Turbine Emissions at Simulated Flight Altitude Conditions. Ed. Robert Howard, AEDC TR-96-3 June 1996.</b></p>

<p>SNIFF Feb '96 NASA-AEA</p>	<p>TCN/NVCN/SD</p>	<p>GT B737 B757 T-38</p>	<p>log normal distribution peak dia. &lt;100nm typ.[part] &gt; 10<sup>7</sup> cm<sup>-3</sup> SMF - negligible Significant difference in EI(CN) between L&amp;R engines of B737, consistent with Langley LIDAR measurements.  NASA-AEA Workshop Virginia Beach 1997.</p>
<p>DLR Sulf3 Mar '96 UMR</p>	<p>TCN/NVCN</p>	<p>GT &amp; FL ATTAS AB300</p>	<p>First particulate sampling &lt;100m separation in flight with fuel sulfur content varying between 6 and 2700ppm. NVCN did not vary as a function of [Sulf].  Near field measurements on contrail properties from fuels with different sulfur content. JGR in press Jul '97</p>
<p>SUCCESS May '96 NASA-AEA UMR</p>	<p>TCN/NVCN/SD LAS/HYD/CFX</p>	<p>RB-211 FL</p>	<p>Significant increase in EI(CN) with increasing fuel sulfur content From 2-10km separation between B757 &amp; DC8 EI(CN) decreases with increasing separation distance  2 GRL's submitted Jun 97: a. Particle concentration characterization for jet engine emissions under cruise conditions. b. Particulate sizing and emission indices for a jet engine exhaust sampled at cruise.</p>
<p>LeRC-PSL1 Jun '96 NASA-AEA UMR</p>	<p>TCN/NVCN/SD /HYD/SEM</p>	<p>ASC</p>	<p>currently subject to a non- disclosure agreement.</p>
<p>LeRC-FT Sep '96 NASA-AEA UMR</p>	<p>TCN/NVCN/SD /HYD/SEM</p>	<p>RQL FT LDI FT</p>	<p>currently subject to a non- disclosure agreement.</p>

MO-ANG Feb '97 MDAE	TCN/NVCN/SD /LPC/SEM	GT F100 -100	log-normal distributions peak dia. <100nm EI(CN) comparable to commercial fleet, increases with thrust in 60-80% range  Report due Jan 98 following 2nd phase of study with +100 fuel additive.
WPAFB Fuels Current AFOSR UMR	TCN/NVCN/SD /LPC/SEM	Lab WSR TVComb.	Work in progress  Report on first phase due Dec 1997
NJ-ANG Jun '97 NASA-AEA UMR	TCN/NVCN/SD /LPC/SEM	GT F100 -220	log-normal distributions peak dia. <100nm EI(CN) comparable to commercial fleet, no strong dependence on thrust
LeRC-PSL2 Current NASA-AEA UMR	TCN/NVCN/SD /LPC/SEM	ASC F100 -220	Measurements Aug/Sep 97
POLINAT2- SONEX Sep '97 NASA-AEA DLR UMR	TCN/NVCN/SD HYD/LPC/SEM		Measurements Sep/Oct 97



## AIRBORNE OBSERVATIONS OF AEROSOL EMISSIONS FROM F-16 AIRCRAFT

B.E. Anderson, W.R. Cofer, and D.S. McDougal  
NASA Langley Research Center  
Hampton, Virginia

We presented results from the SASS Near-Field Interactions Flight (SNIF-III) Experiment which was conducted during May and June 1997 in collaboration with the Vermont and New Jersey Air National Guard Units. The project objectives were to quantify the fraction of fuel sulfur converted to S(VI) species by jet engines and to gain a better understanding of particle formation and growth processes within aircraft wakes. Size and volatility segregated aerosol measurements along with sulfur species measurements were recorded in the exhaust of F-16 aircraft equipped with F-100 engines burning fuels with a range of fuel S concentrations at different altitudes and engine power settings. A total of 10 missions were flown in which F-16 exhaust plumes were sampled by an instrumented T-39 Sabreliner aircraft. On six of the flights, measurements were obtained behind the same two aircraft, one burning standard JP-8 fuel and the other either ~28 ppm or 1100 ppm S fuel or an equal mixture of the two (~560 ppm S). A pair of flights was conducted for each fuel mixture, one at 30,000 ft altitude and the other starting at 35,000 ft and climbing to higher altitudes if contrail conditions were not encountered at the initial flight level. On each flight, the F-16s were operated at two power settings, ~80% and full military power. Exhaust emissions were sampled behind both aircraft at each flight level, power setting, and fuel S concentration at an initial aircraft separation of 30 m, gradually widening to ~3 km.

Analyses of the aerosol data in the cases where fuel S was varied suggest results were consistent with observations from project SUCCESS, i.e., a significant fraction of the fuel S was oxidized to form S(VI) species and volatile particle emission indices (EIs) in comparably aged plumes exhibited a nonlinear dependence upon the fuel S concentration. For the high sulfur fuel, volatile particle EIs in 10-second-old plumes were  $2$  to  $3 \times 10^{17} \text{ kg}^{-1}$  fuel burned and exhibited no obvious trend with engine power setting or flight altitude. In contrast, ~8-fold fewer particles were observed in similarly aged plumes from the same aircraft burning fuel with 560 ppm S content and EIs of  $< 1 \times 10^{15} \text{ kg}^{-1}$  fuel burned were observed in the 28 ppm S fuel case. Moreover, data recorded as a function of plume age indicates that formation and growth of the volatile particles proceeds more slowly as the fuel S level is reduced. For example, ultrafine particle concentrations appear to stabilize within 5 seconds after emission in the 1100 ppm S cases but are still increasing in 20-second old plumes produced from burning the 560 ppm S fuel.

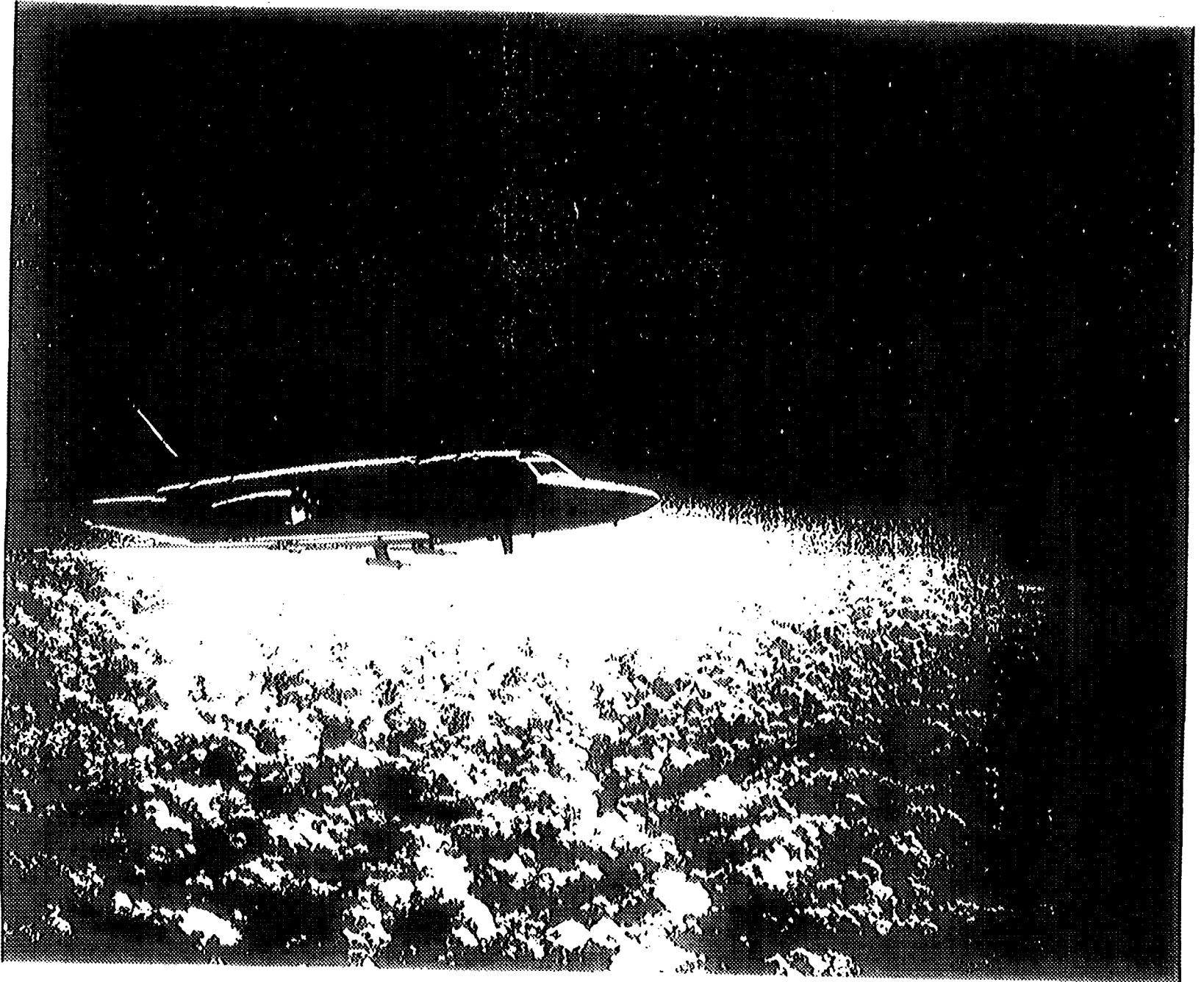

# SUMMARY OF ALL MEASUREMENTS

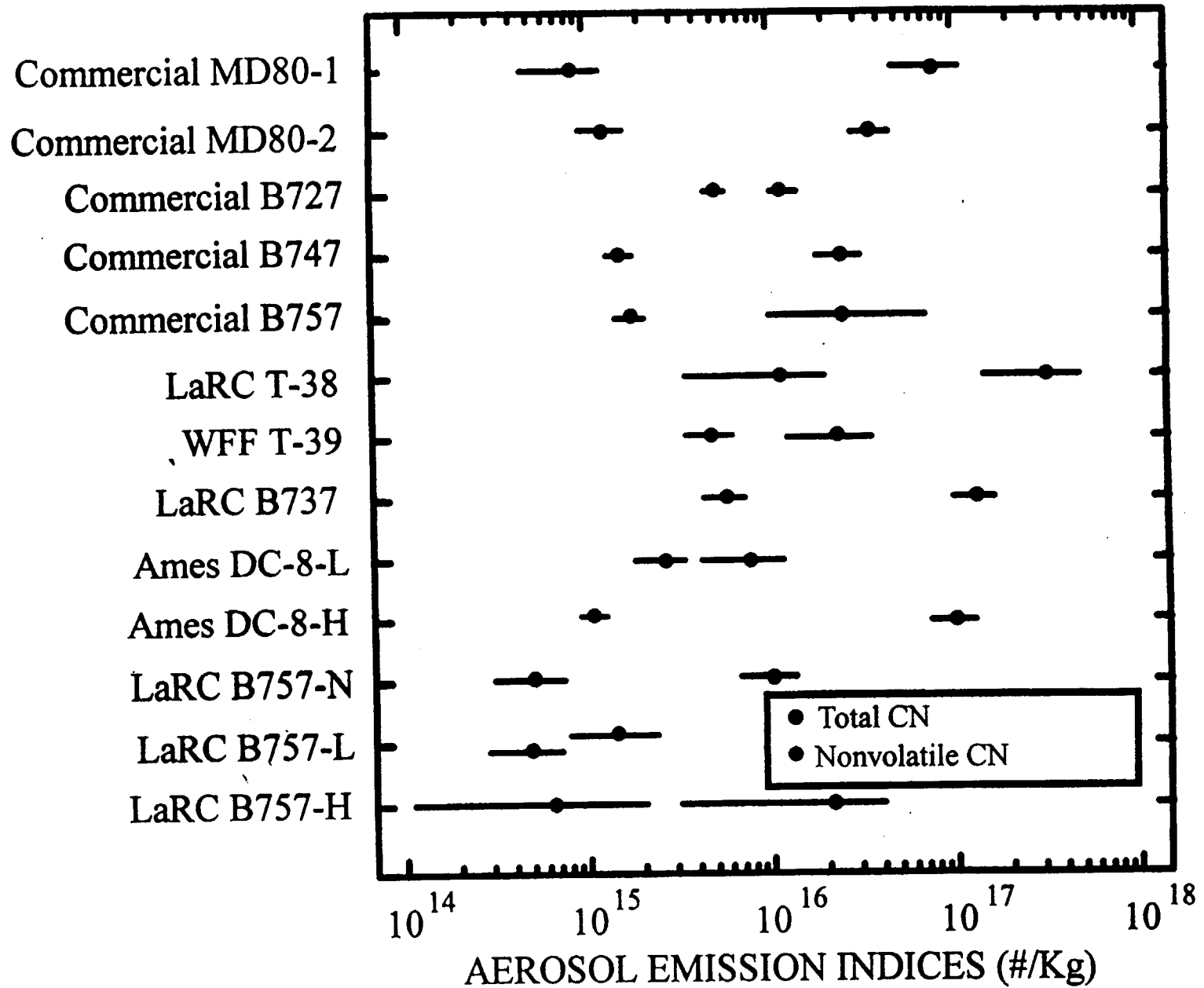

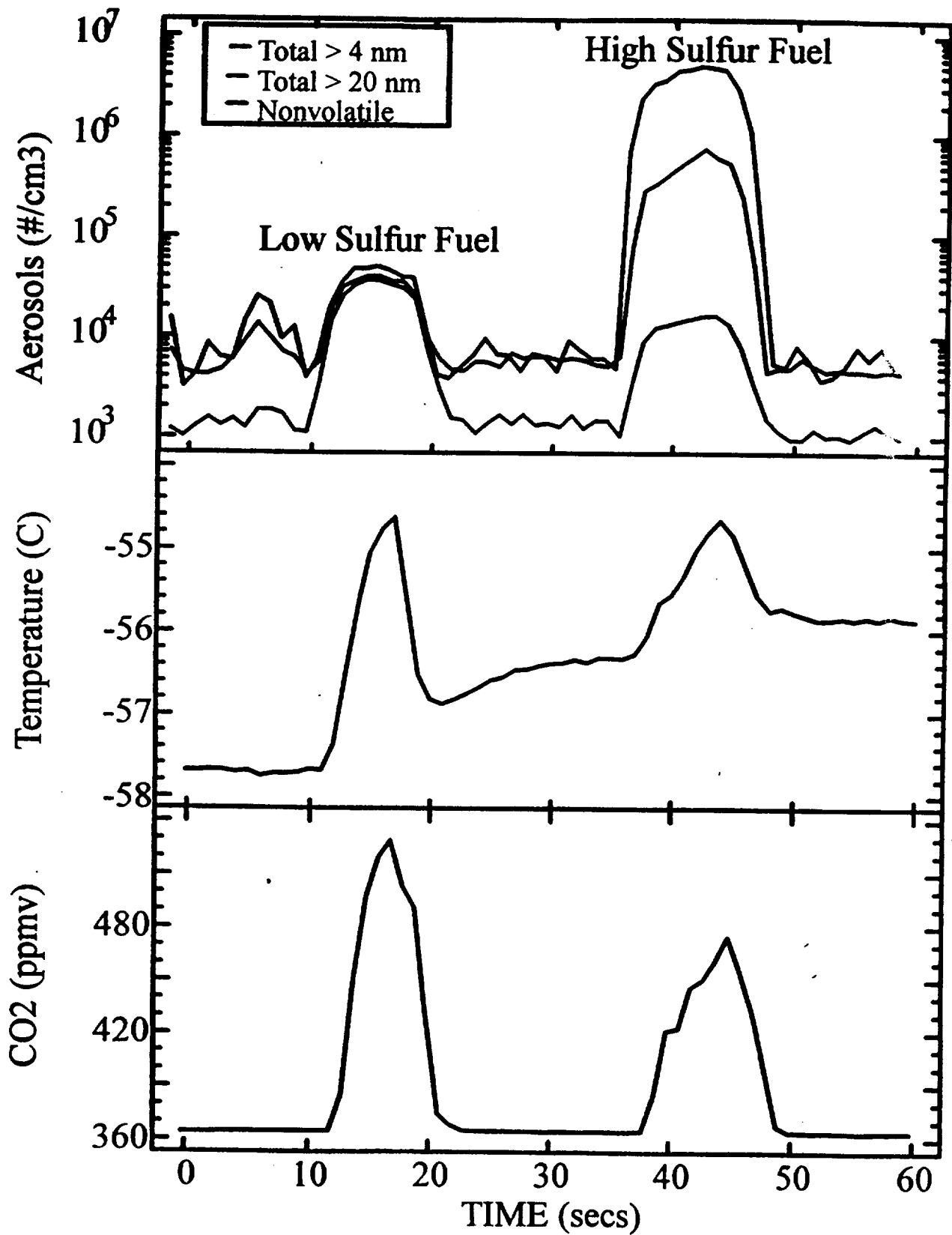

## T-39 Instrument Payload

<u>Parameter</u>	<u>Response</u>	<u>Precision</u>
CO <sub>2</sub>	10 Hz	0.1 ppm
Tdew	.2 Hz	1 deg
T	20 Hz	0.1 deg
u, v, w	10 Hz	0.5 m/s
P, alt	10 Hz	0.1 mb, 10 m
Total CN > 4 nm	2 Hz	10 %
Total CN > 15 nm	2 Hz	10 %
Total CN > 23 nm	2 Hz	10 %
Nonvolatile CN > 4 nm	2 Hz	10 %
Nonvolatile CN >15 nm	2 Hz	10 %
Aerosol Size 0.1 to 3.0 $\mu$ m	10 Hz	20 %

**SO<sub>2</sub>, H<sub>2</sub>SO<sub>4</sub>, HNO<sub>3</sub>, HONO: Impactor Grids**

# **Source Aircraft**

## **Test/Warm-up Flights**

Air Force C-5A Galaxy

Wallops C-130 (2 flights)

Wallops BE-200 King Air (2 flights)

Langley B-737-100 (2 flights)

## **Aircraft with F-100 Series 220 Engines**

Vermont Air National Guard F-16s

5 different aircraft, 2 flights

JP-8+100 fuel

New Jersey Air National Guard F-16s,

4 different aircraft, 8 flights

5 different fuel mixtures

## SNIF-III Experiment Test Matrix

Fuel Sulfur	Low	Medium	High
Environmental parameters	T, P, Q (altitude)	T, Q, P (altitude)	T, Q, P (altitude)
Aircraft Parameters	power	power	power
Plume Age 30 meters + + + + + + 2 km			

SNIF-III Test Matrix for Individual Fuel

## SNIF-III Test Matrix for Individual Fuels

Altitude	30 kft		35 kft		Con Alt
Power Setting	78%	88%	78%	85%	85%
Separation Distance	30 m	30 m	30 m	30 m	30 m
	200 m	200 m	200 m	200 m	200 m
	400 m	400m	400 m	400 m	400 m
	...	...	...	...	...
	...	...	...	...	...
	...	...	...	...	...
	2000 m	2000 m	2000 m	2000 m	2000 m



(X 1.0E15)

# NONVOLATILE AEROSOL EMISSIONS

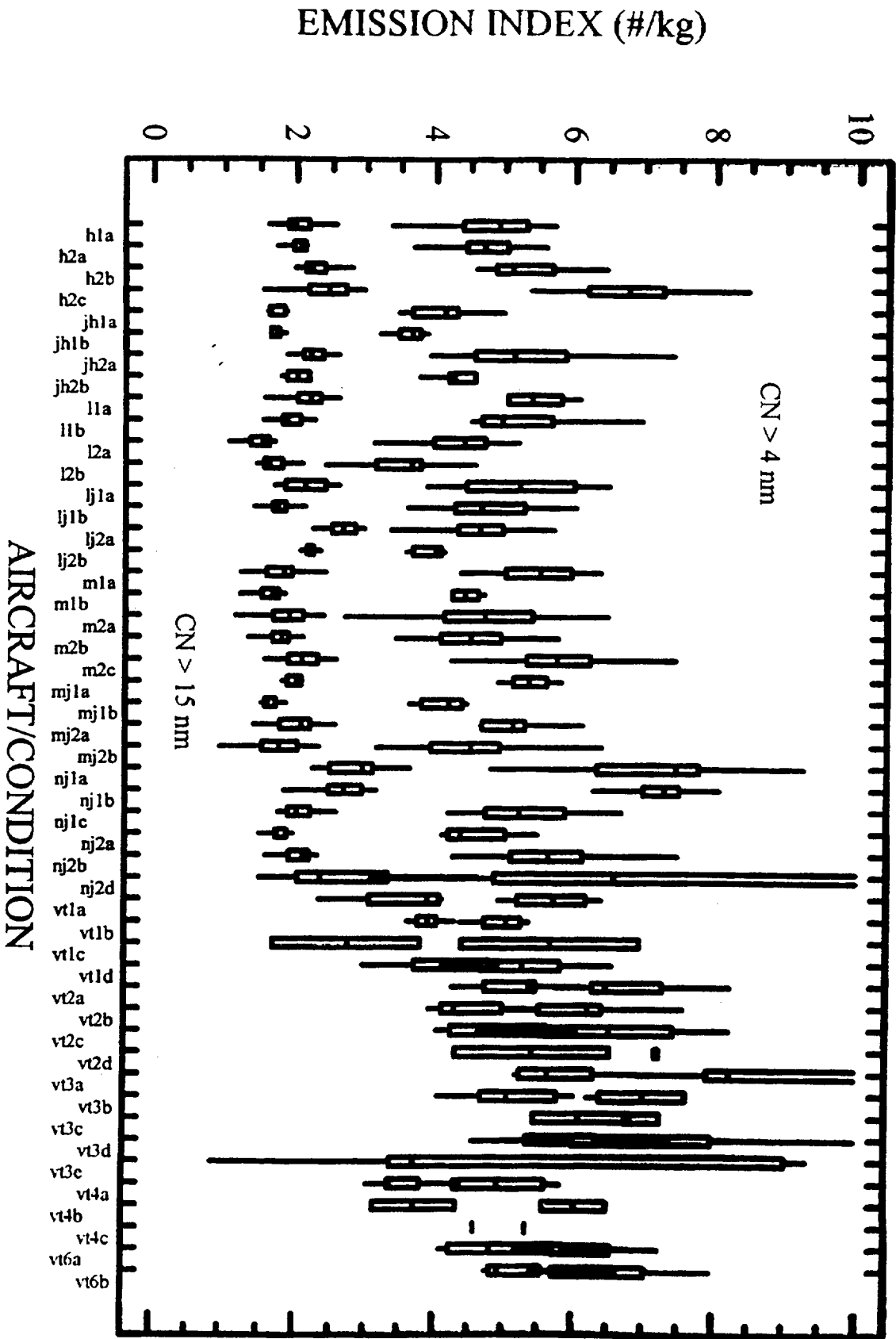

AIRCRAFT NONVOLATILE EMISSIONS

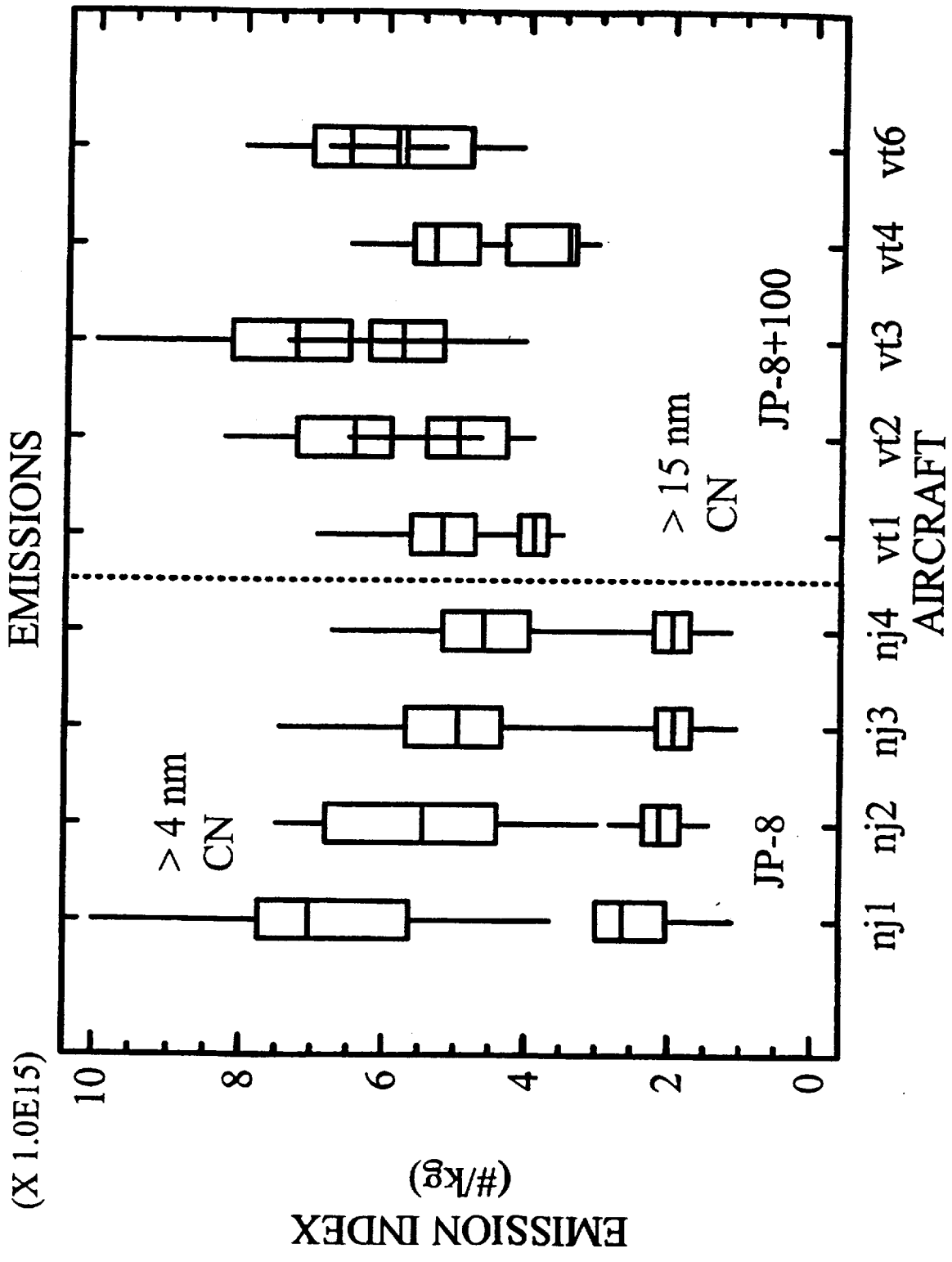

# ULTRAFINE AEROSOL EMISSIONS

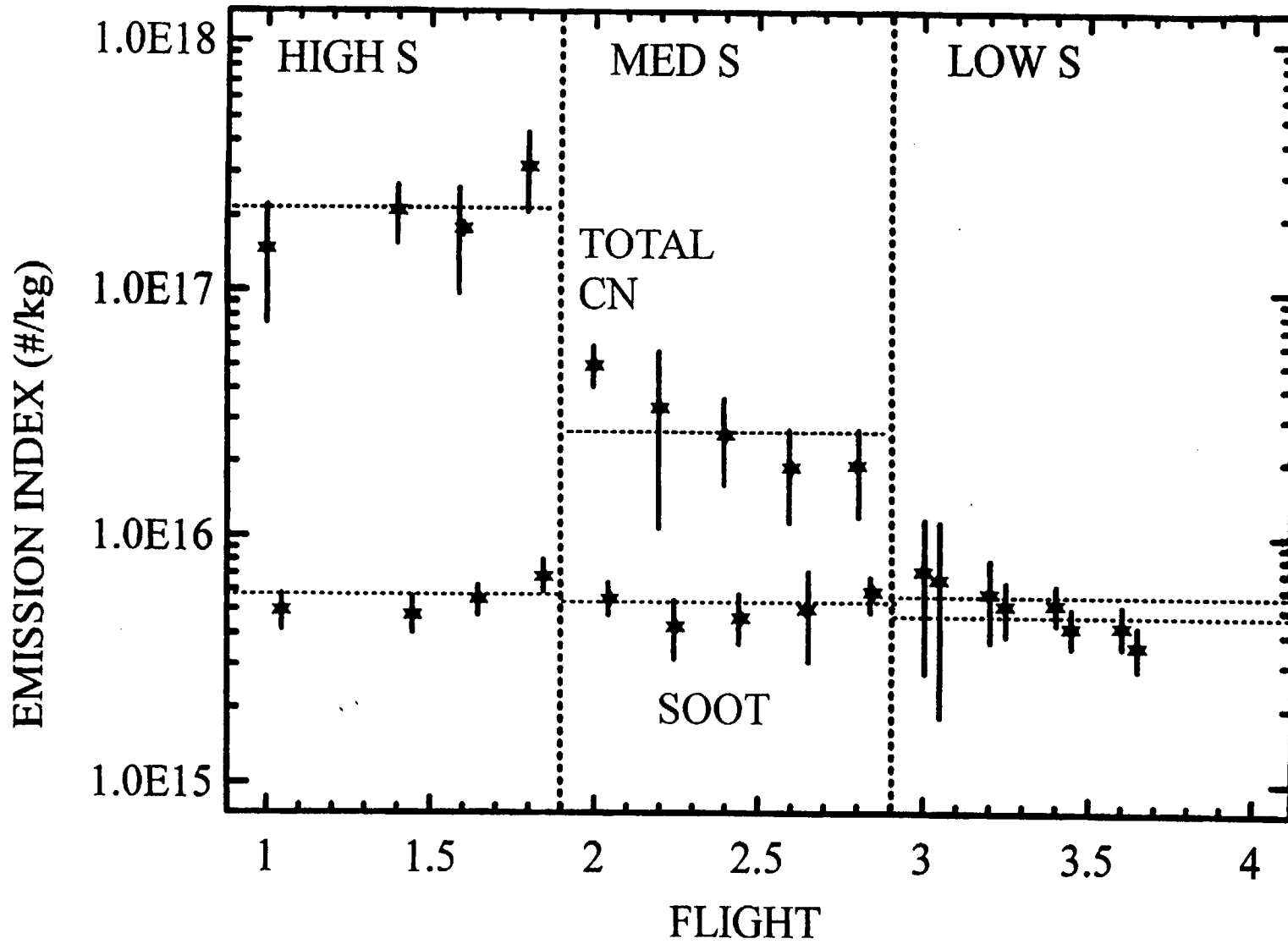

# JP-8 AC ULTRAFINE EMISSIONS

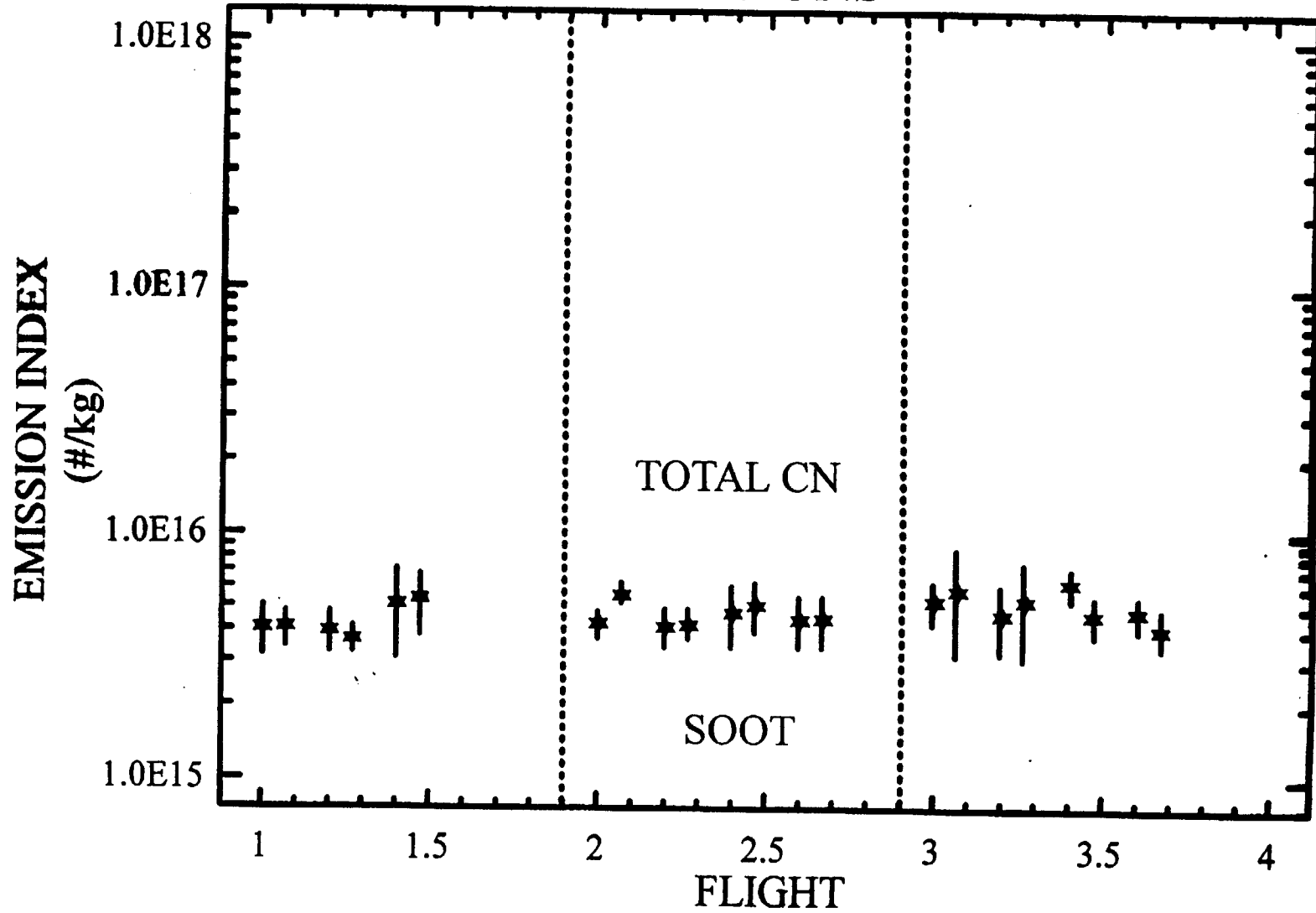

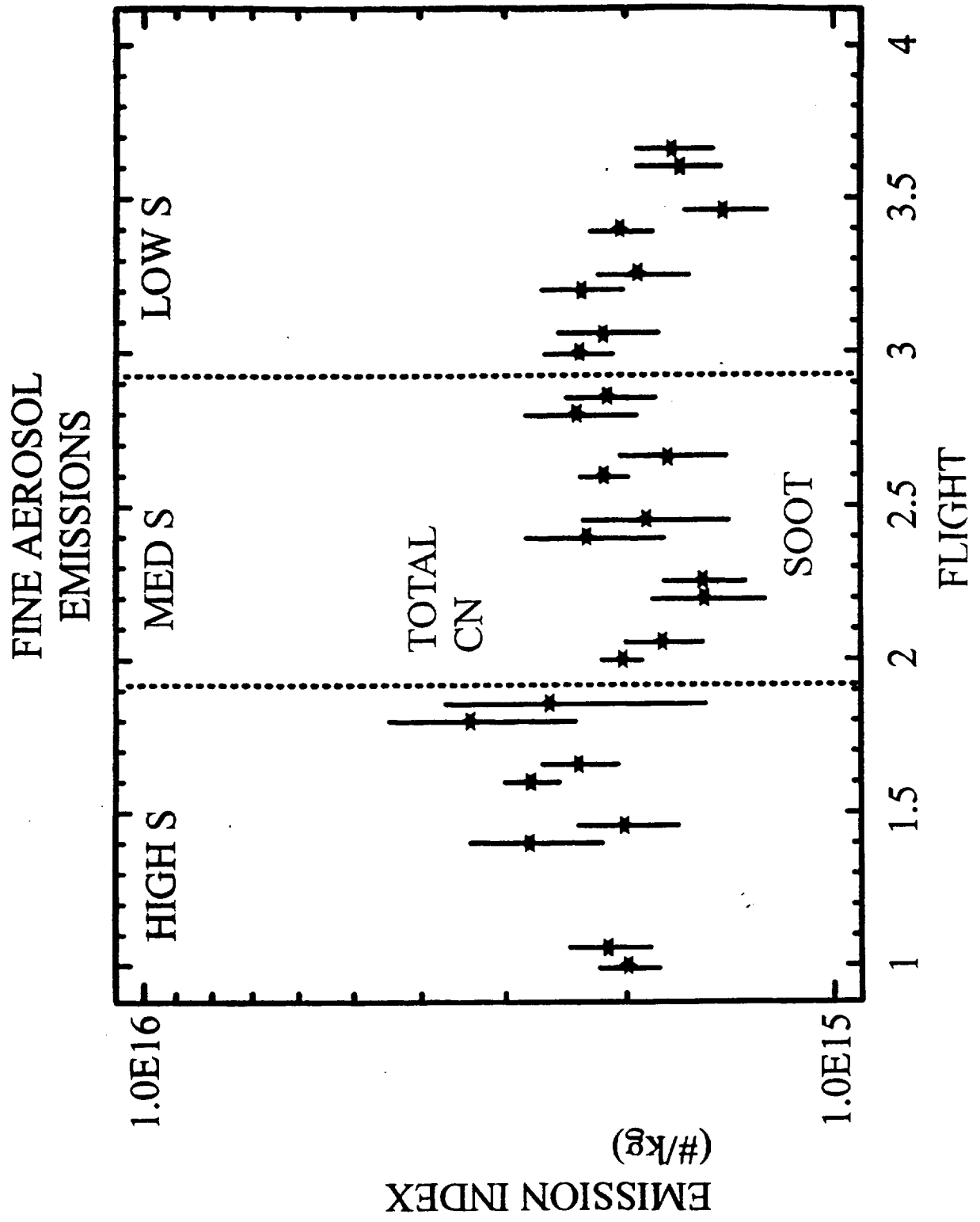

# JP-8 AC FINE EMISSIONS

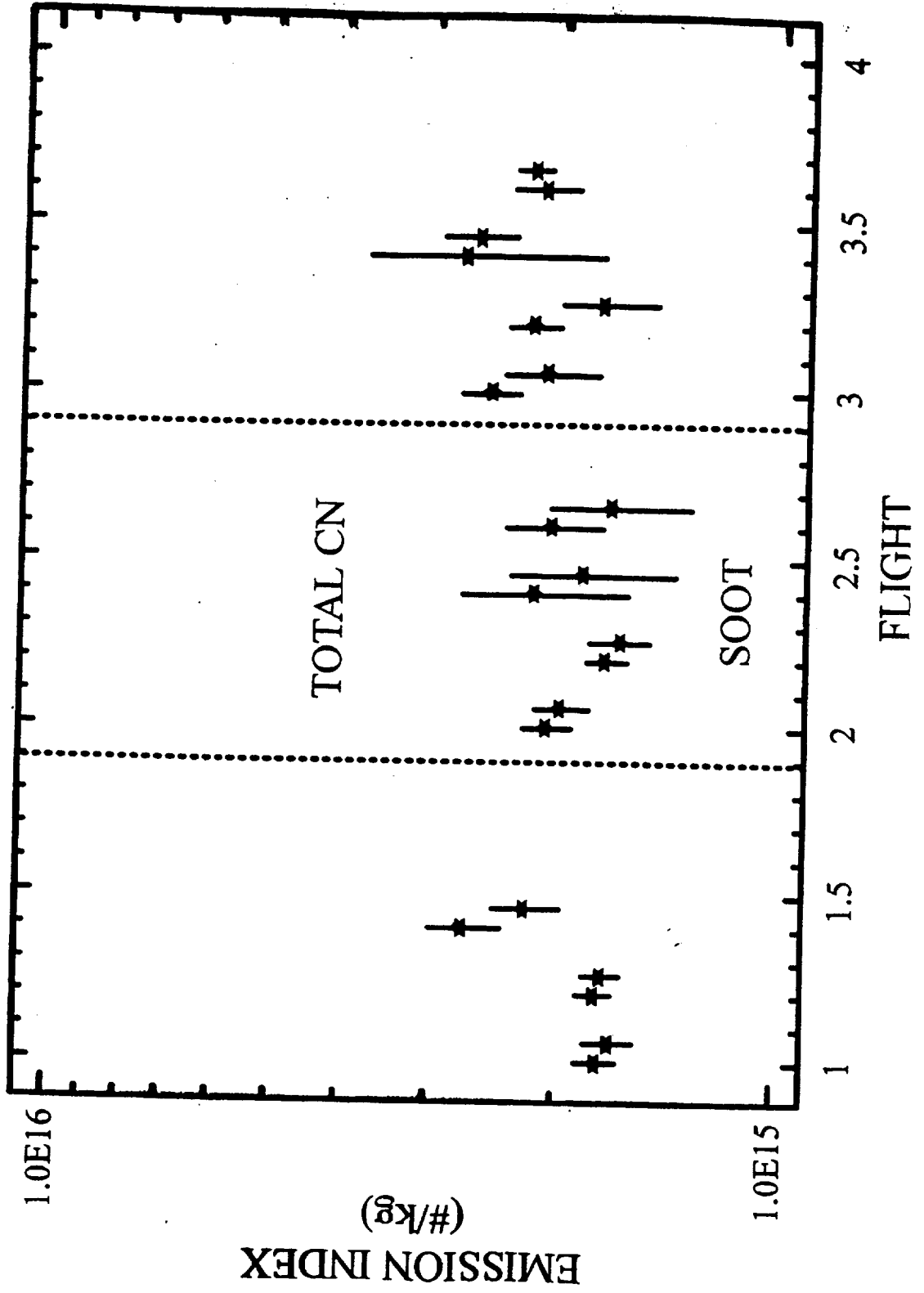

# FINE AEROSOL EMISSIONS

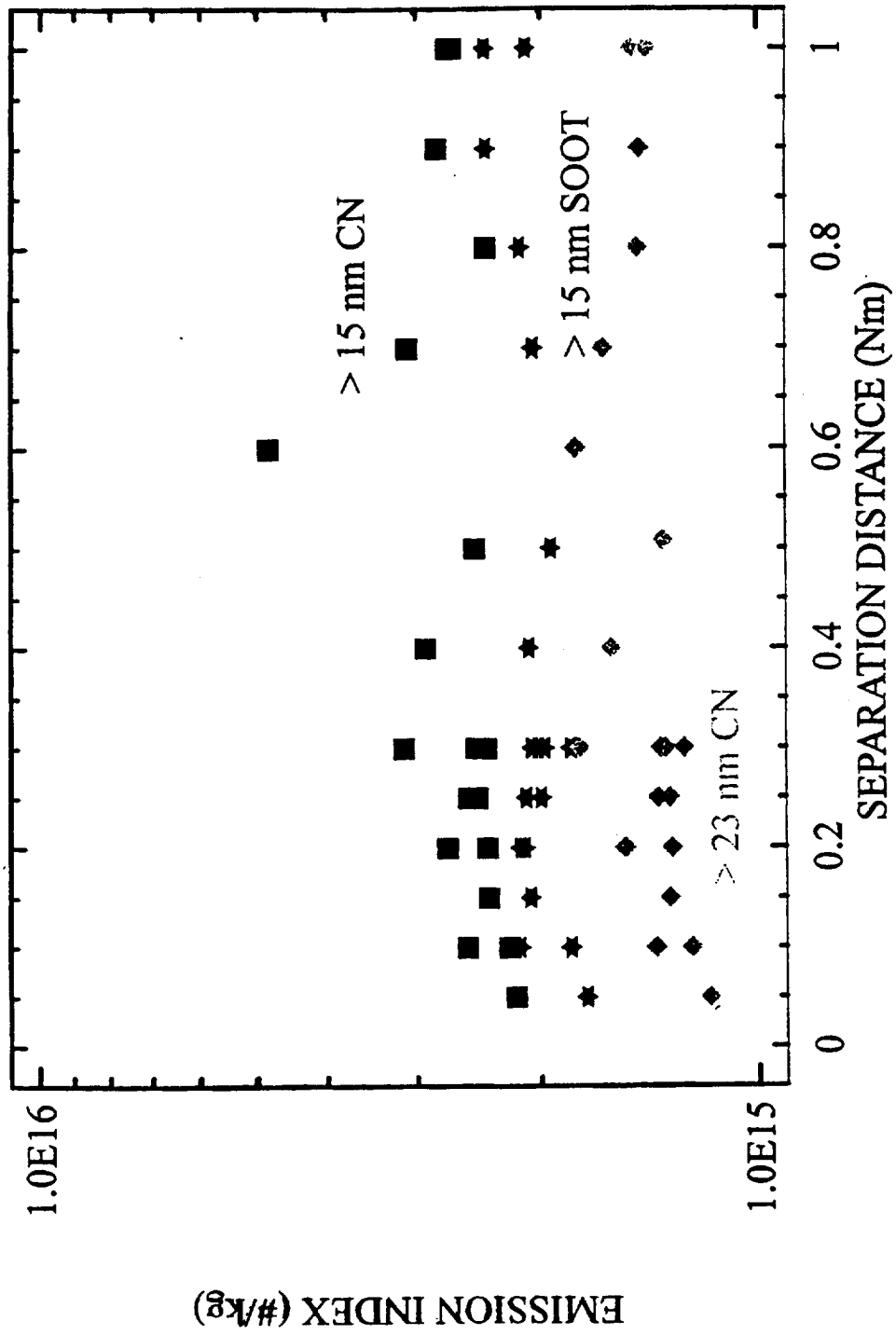

# ULTRAFINE AEROSOLS

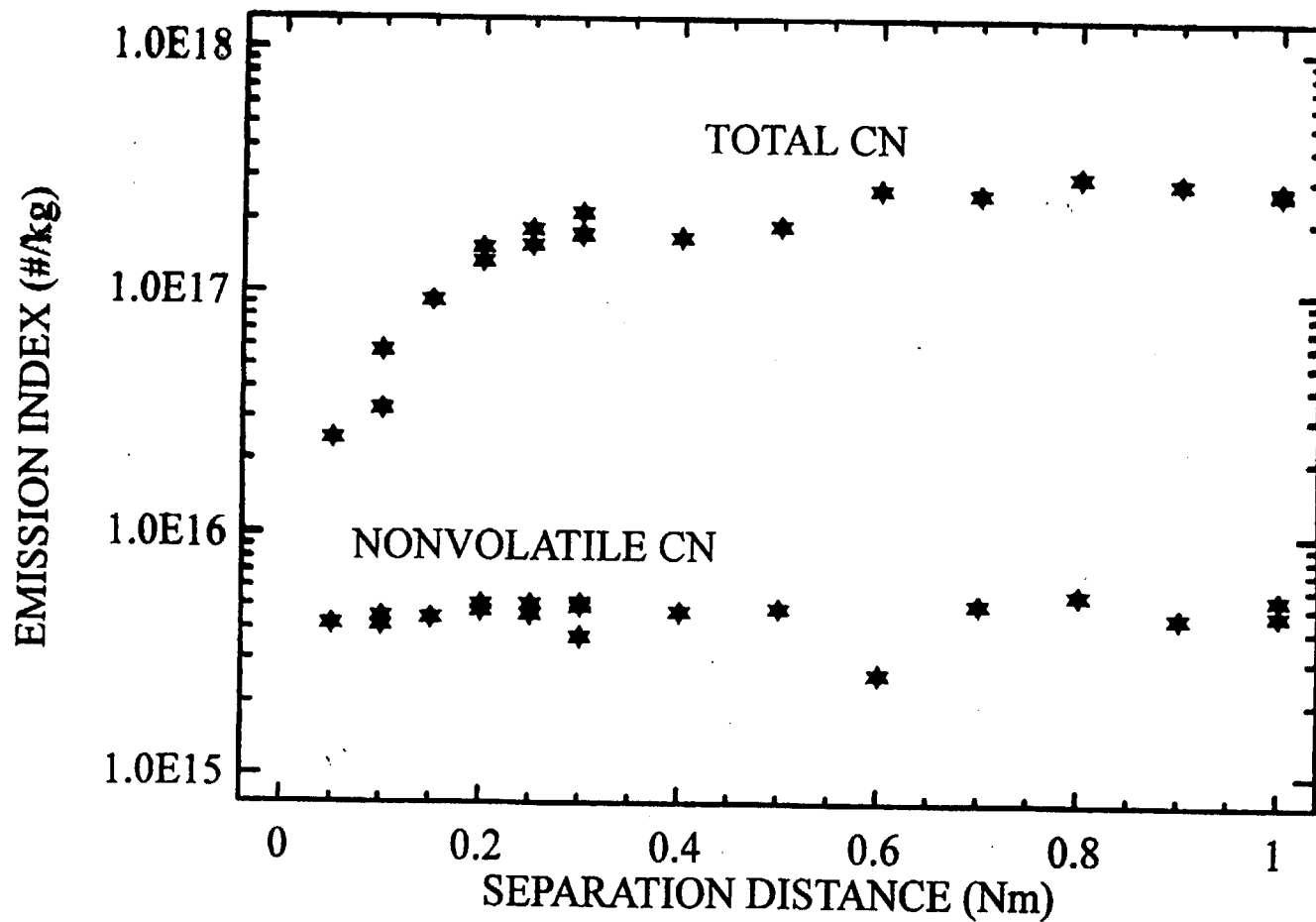



# Preliminary Observations

- F-100s emit  $\sim 6 \times 10^{15}$  particles  $> 4$  nm at typical cruise conditions.
- F-100s burning JP-8 + 100 tend to emit larger particles than those burning standard JP-8.
- Ti and Si aerosols are present in aircraft exhaust plumes.
- The concentration of fuel sulfur controls the emission of volatile particles by aircraft.
- Volatile aerosols are typically  $< 15$  nm in size and their number densities vary non-linearly with fuel S concentration.
- Nonvolatile particles are present early in plume and the number  $> 4$  nm in diameter increase 10 fold in the first 5 seconds after emission.

## **Some Remaining Questions**

- **What is the size distribution of the volatile aerosols and how does this change in time? What is the equilibrium concentration of particles in aged aircraft plumes?**
- **What factors control new particle formation? Why is process apparently non-linear with fuel S? What fraction of H<sub>2</sub>SO<sub>4</sub> is deposited on soot particles?**
- **What fraction of the CN in aged aircraft plumes are active as IN and CCN?**
- **Are substantial #s of Ti and Si particles generated by aircraft?**
- **Does the fraction of fuel S oxidized to S(VI) vary substantially between engines?**
- **Would contrails form if [fuel sulfur] = 0?**

## WORKSHOP ON AEROSOLS AND PARTICULATES FROM AIRCRAFT GAS TURBINE ENGINES

Harvey V. Lilienfeld  
McDonnell Douglas Corporation  
St. Louis, Missouri

Prior to 1990, the major source of measurements on particulate emissions from aircraft utilized the measurement of 'smoke numbers'. This technique was developed to quantify the light scattering properties of engine exhaust, but is not directly applicable for modeling of the effects of engine particulates on the atmosphere. The data base for particulate emissions from aircraft flying in the atmosphere has increased dramatically in the last few years due to the implementation of equipment capable of measuring particle number densities, size distributions, hydration properties and emission indices. This equipment was developed to quantify engine exhaust emissions because of concerns of the environmental impact of supersonic and subsonic aircraft.

This paper reports on the status of the data base obtained from these measurements and reports on the correlations currently being used to characterize the current and future fleets of aircraft flying in the troposphere and stratosphere.

As a result of project Pollinet, a European campaign to measure the effects of emissions of subsonic aircraft, a number of particle emission indices were measured by workers from the University of Missouri Rolla and their associates. These results for particle emission indices (particles/kg fuel burned) for both total particles and non-volatile particles (particles remaining after volatile particles are removed by heating to 170C) are correlated for a number of aircraft/engine combinations flight at 300 hft. The agreement among engine types for non-volatile particles (assumed to be predominantly soot) is generally good (within 20%) with a range among the aircraft intercepted of  $2 \times 10^{14}$  -  $2 \times 10^{15}$  particles/Kg fuel. These data were also correlated with smoke numbers obtained from the ICAO data base.

Work-in-progress data base correlations are described for an assortment size distributions obtained from measurements on the ground, in the air and in altitude chambers taken during the NASA sponsored projects SNIF and SUCCESS.

Interesting measurements of a NASA owned 737 aircraft with JT8 engines and a 757 aircraft with RB-211-535C engines are described. The 757 aircraft is of interest because of the difference seen for particles emissions between the port and starboard engines. This case is interest because it is very atypical for results to vary this much between engines of the same type.

Measurements of emission indices on the ground and in the air for the 757 aircraft are compared. In addition, measurements of this aircraft by several groups are compared.

Measurements taken on the ground and in flight for military aircraft flying with F100 engines are compared. The older version of the F100 engine (F100-100 servies) appears to have a greater emissions than the later (F100-200) model at high thrust settings. The emissions from both of these older engines is more than an order of magnitude greater than the emissions from a modern engine. These results indicate the improvements made by industry of the past several decades on particulate emissions.

The size distributions of particles emitted from these aircraft appear to change somewhat as a function of thrust setting. Size distributions among the engine models (F100-100 vs F100-200) are compared but the differences noted may represent different operating conditions as well as differences among engine models.

Date	Time UTC	Plane	Engine	Level hft	press hPa	T °C	Fuel t/hr	EI Total (kg fuel <sup>-1</sup> )	EI Non-Volatile (kg fuel <sup>-1</sup> )
30 Jun 95	13:30	B747	CF6-80C2B1F	370	216.6	-59	8.4		8.9x10 <sup>14</sup>
30 Jun 95	13:53	B747	JT9D-7A	326	266.9	-47	13.6		3.3x10 <sup>14</sup>
30 Jun 95	14:32	B747	JT9D-7A	330	262.0	-47	12.0		5.4x10 <sup>14</sup>
3 Jul 95	13:50	B747	CF6-50E2	350	238.4	-51	12.0	5.8x10 <sup>15</sup>	2.7x10 <sup>14</sup>
3 Jul 95	14:25	DC10	CF6-50C	330	262.0	-46.5	13.13	4.5x10 <sup>15</sup>	4.6x10 <sup>14</sup>
3 Jul 95	14:50	B747	JT9D-7J	330	262.0	-46	7.35	9.9x10 <sup>15</sup>	4.5x10 <sup>14</sup>
3 Jul 95	15:30	B747	JT9D-7A	330	262.0	-47		8.1x10 <sup>14</sup>	5.7x10 <sup>14</sup>
5 Jul 95	2:28	B747	CF6-50E2	350	238.4	-51	10.4	1.8x10 <sup>15</sup>	5.3x10 <sup>14</sup>
5 Jul 95	3:28	EA34	CFM56-5C2	350	238.4	-51	6.0	2.9x10 <sup>16</sup>	1.6x10 <sup>15</sup>

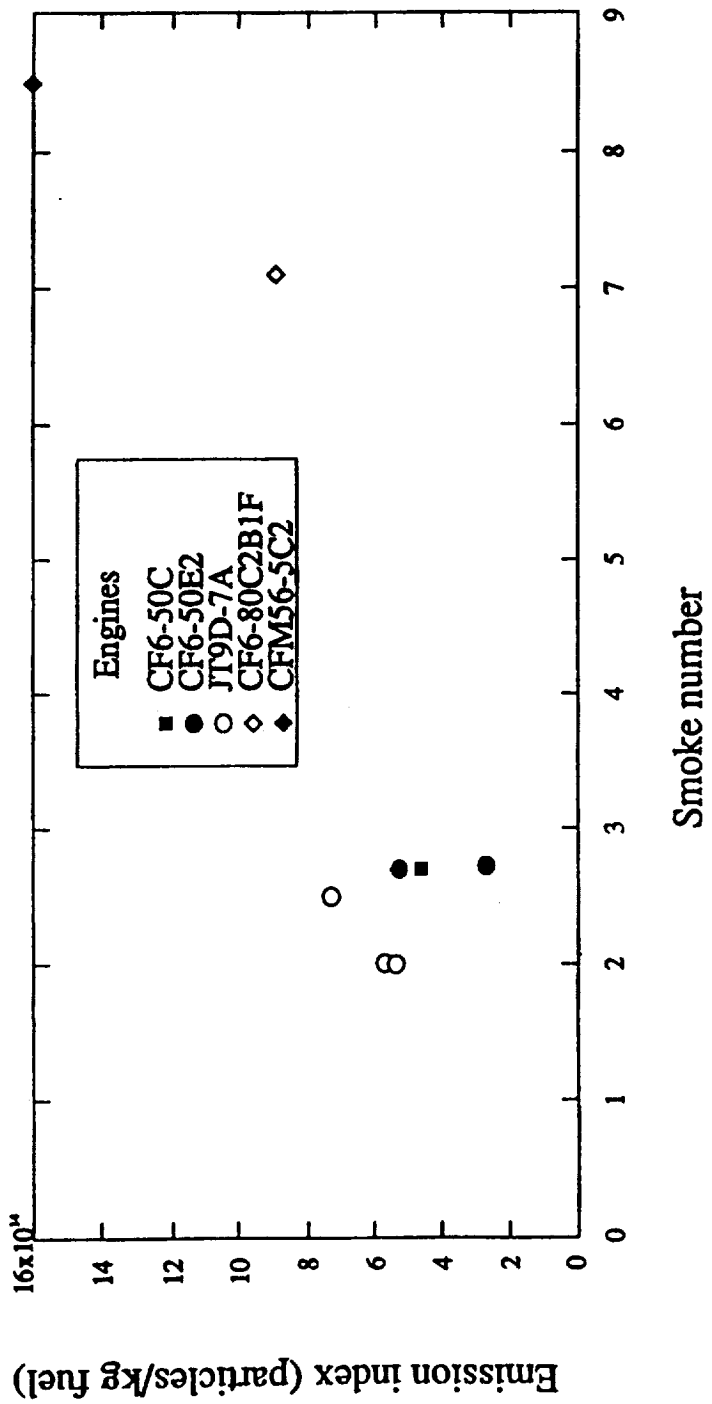

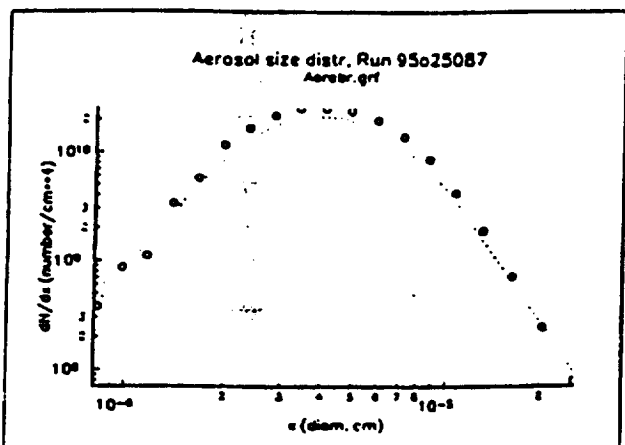

† 9.1 km  $\rho_{la} = 860$

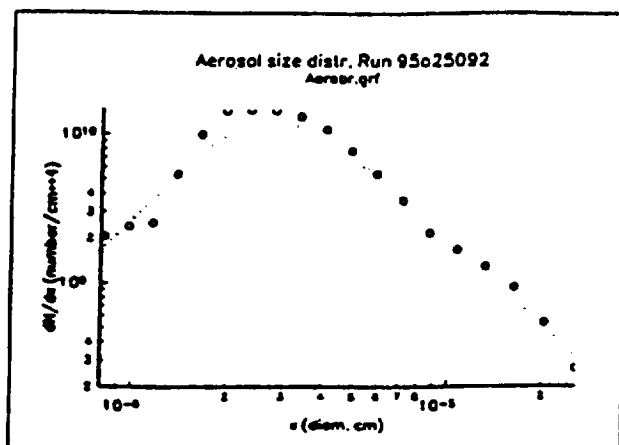

9.1 km  $\rho_{la} = 750$

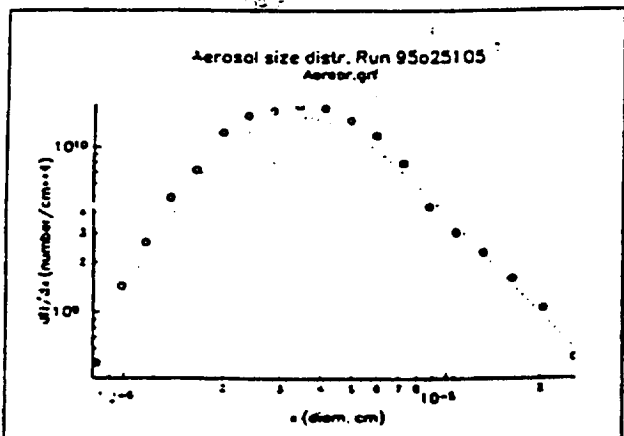

12.2 km

$T_3 = 727 K$

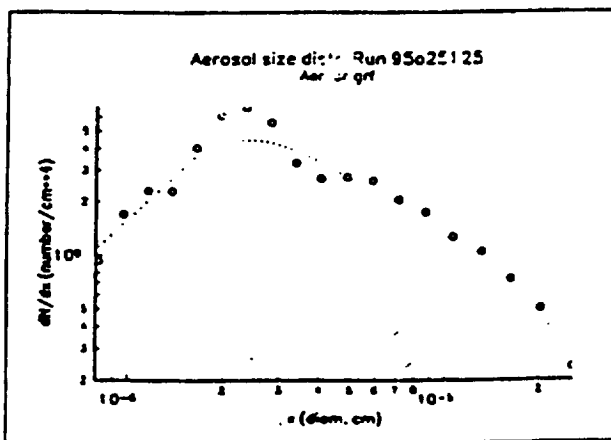

12.2 km

$T_3 = 665 K$

## Database Correlations

1) Characterize each distribution according to shape.

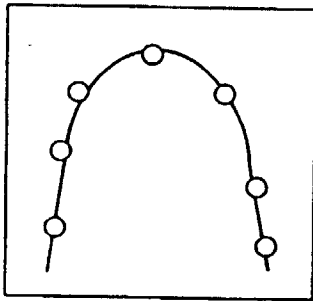

1

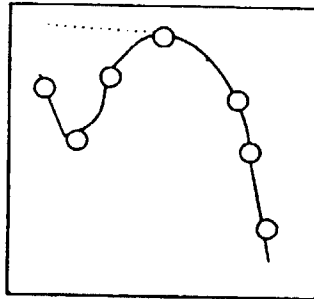

2

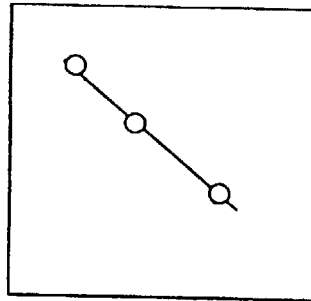

3

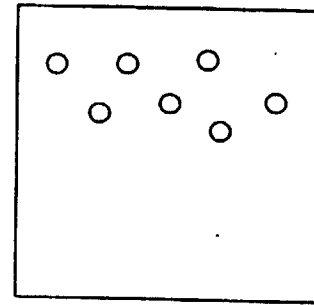

4

901

2) Determine fraction of distribution with diameters  $>100$  nm.

3) For types 1 and 2 determine the number of nodes

4) For types 1 and 2 determine the peak size and  $l_{10\%}$  and  $r_{10\%}$   
(the left and right 10% widths)

5) Calculate areal mean diameter

6) Calculate volume mean diameter



Name	Shape	Fraction	# Modes	Left 10% (nm)	Peak1 (num/cm <sup>4</sup> )	Peak2 (num/cm <sup>4</sup> )	Peak3 (num/cm <sup>4</sup> )	Right 10% (nm)	Slope
1	1	0.065	1	0	1.8E+10	0	0	190	0
2	1	0.086	1	0	1.8E+10	0	0	190	0
9	1	0.0013	1	0	6.00E+10	0	0	70	0
10	1	0.006	1	0	6E+10	0	0	70	0
12	1		1	0	5.00E+10	0	0	70	0
13	1		1	0	5.00E+10	0	0	70	0
21	1		1	0	6.00E+10	0	0	70	0
26	2		1	0	9.00E+11	0	0	180	0
27	2		1	0	9.00E+11	0	0	180	0
29	2		1	0	2.00E+10	0	0	70	0
39	2		2	0	3.00E+09	4.00E+11	0	200	0
51	1		1	0	3.00E+10	0	0	120	0
56	1		1	9	3.00E+10	0	0	90	0
57	1		1	9	3.00E+10	0	0	90	0
59	1		1	9	3.00E+10	0	0	90	0
64	1		1	15	3.00E+10	0	0	90	0
69	1		1	0	1.00E+11	0	0	0	0
76	1		1	0	2.50E+10	0	0	200	0
77	1		1	10	2.00E+10	0	0	100	0
79	1		1	10	2.00E+10	0	0	100	0
82	1		1	15	2.00E+10	0	0	180	0
87	1		1	14	2.00E+10	0	0	140	0
82	1		1	14	2.00E+10	0	0	140	0
92	1		1	0	1.00E+10	0	0	150	0
93	1		1	0	1.00E+10	0	0	150	0
95	1		1	0	1.00E+10	0	0	100	0
105	1		1	0	1.7E+10	0	0	160	0
106	1		1	11	1.1E+10	0	0	160	0
108	1		1	10	3.1E+10	0	0	150	0
113	1		1	10	2.2E+10	0	0	130	0
118	1		1	16	1.5E+10	0	0	0	0
119	1		1	16	1.5E+10	0	0	0	0
125	1		1	0	6E+09	0	0	0	0
130	1		1	0	4E+09	0	0	150	0
135	1		2	0	6.00E+06	5.00E+06	0	0	0
138	1		1	9.5	8E+08	0	0	80	0
143	1		1	9.5	2.5E+09	0	0	80	0
151	2		1	0	5E+10	0	0	120	0
156	1		1	13	2.8E+10	0	0	150	0
157	1		1	13	2.8E+10	0	0	150	0
162	1		1	14	3.5E+10	0	0	140	0
163	1		1	14	3.5E+10	0	0	140	0
169	1		1	17	1.50E+10	0	0	0	0
172	1		1	11	1E+12	0	0	120	0
175	1		1	9	4E+10	0	0	85	0
176	1		1	9	4E+10	0	0	85	0
178	1		1	10	3.5E+10	0	0	160	0
179	1		1	10	3.5E+10	0	0	160	0
183	1		1	0	1.5E+09	0	0	90	0
188	1		1	0	9E+10	0	0	100	0
193	1		1	11	6.5E+10	0	0	95	0
196	1		1	13	1.7E+10	0	0	0	0

Aerosol size distr, 96209vak&cb  
Thrust 3100

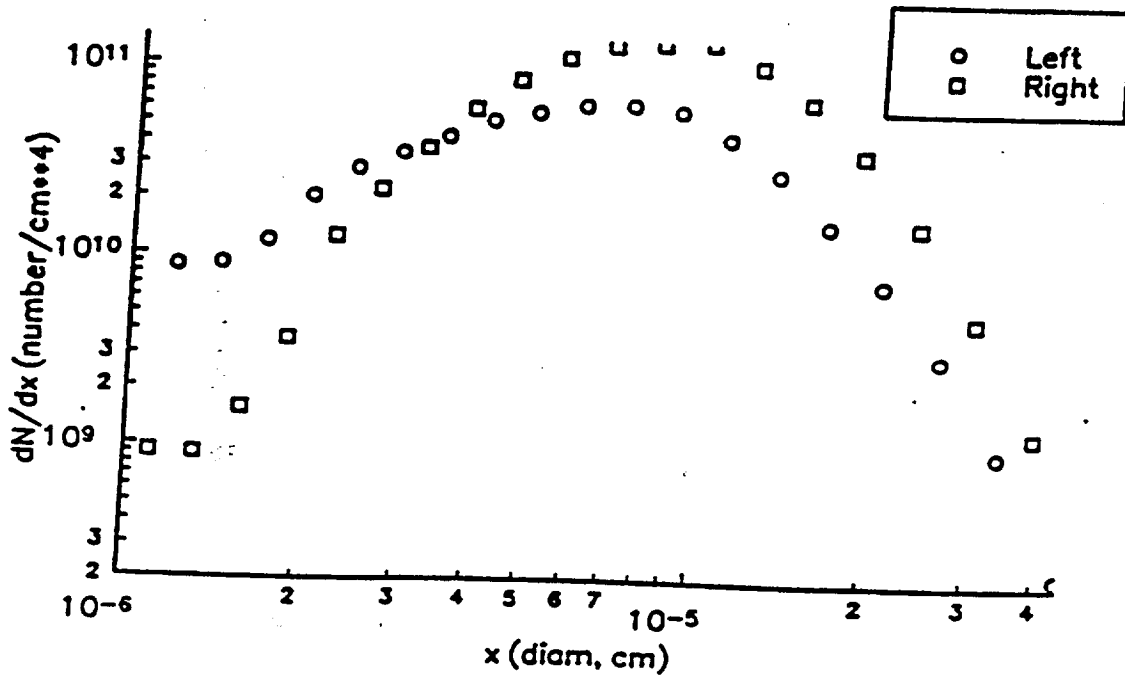

B737

## 737 JT8

lbs fuel/hr	E.I. (Total particles) part/kg fuel	E. I. (Nonvolatile Particles) part/kg fuel
1200 right	$4.30 \times 10^{15}$	$1.73 \times 10^{15}$
2400 right	$4.79 \times 10^{15}$	$1.97 \times 10^{15}$
3100 right	$8.77 \times 10^{15}$	$3.69 \times 10^{15}$
1200 left	$3.40 \times 10^{15}$	$1.37 \times 10^{15}$
2400 left	$3.69 \times 10^{15}$	$1.52 \times 10^{15}$
3100 left	$3.76 \times 10^{15}$	$1.58 \times 10^{15}$

## 757 RB211-535C

lb fuel /hr	E.I. (Total particles) part/kg fuel	E.I. (Nonvolatile particles) part/kg fuel
3100 right	$8.1 \times 10^{12}$	$6.6 \times 10^{12}$
3100 left	$1.1 \times 10^{13}$	$1.1 \times 10^{13}$
3800 right	$1.3 \times 10^{13}$	$1.1 \times 10^{13}$
3800 left	$1.2 \times 10^{13}$	$9.1 \times 10^{12}$

Total Particle Concentration from 757 flight

	B. Anderson <sup>1</sup>	R. F. Pueschel et. al. <sup>2</sup>	D. Hagen et. al. <sup>3</sup>
High Sulfur	$3 \times 10^{15}$ - $5 \times 10^{16}$	$1$ - $1.6 \times 10^{16}$	$1.4 \times 10^{15}$ - $5.1 \times 10^{15}$
Low Sulfur	$8 \times 10^{14}$ - $3 \times 10^{15}$	$2.1$ - $3.5 \times 10^{15}$	$1.5 \times 10^{14}$ - $1.9 \times 10^{15}$

1. In NASA Reference Publication 1400 Atmospheric Effects of Subsonic Aircraft: Interim Assessment Report of the Advance Subsonic Technology Program R. R. Friedl ed. Godard Space Flight Center Greenbelt Md. 20771 1997

2. R.F. Pueschel et. al. Sulfuric acid and Soot Particle Formation in Aircraft Exhaust - GRL - submitted

3. D. Hagen et. al. Particulate sizing and emission indices for a jet engine exhaust sampled at cruise - GRL submitted

Non-Volatile Particle Concentration from 757 Flight

	B. Anderson <sup>1</sup>	D. Hagen et. al. <sup>2</sup>
High Sulfur	$1 \times 10^{14}$ - $2 \times 10^{13}$	$5 \times 10^{13}$ - $5.5 \times 10^{14}$
Low Sulfur	$3 \times 10^{14}$ - $8 \times 10^{14}$	$1 \times 10^{13}$ - $5.5 \times 10^{14}$

1. In NASA Reference Publication 1400 Atmospheric Effects of Subsonic Aircraft: Interim Assessment Report of the Advance Subsonic Technology Program R. R. Friedl ed. Godard Space Flight Center Greenbelt Md. 20771 1997

2. D. Hagen et. al. Particulate sizing and emission indices for a jet engine exhaust sampled at cruise - GRL submitted

# Methodology for ground testing F100 engines

Record Engine Numbers

Record Tail Numbers

Place probe 1 meter from exhaust on centerline

For each run record :

Thrust (%)

FTIT

Fuel flow

Nozzle Opening

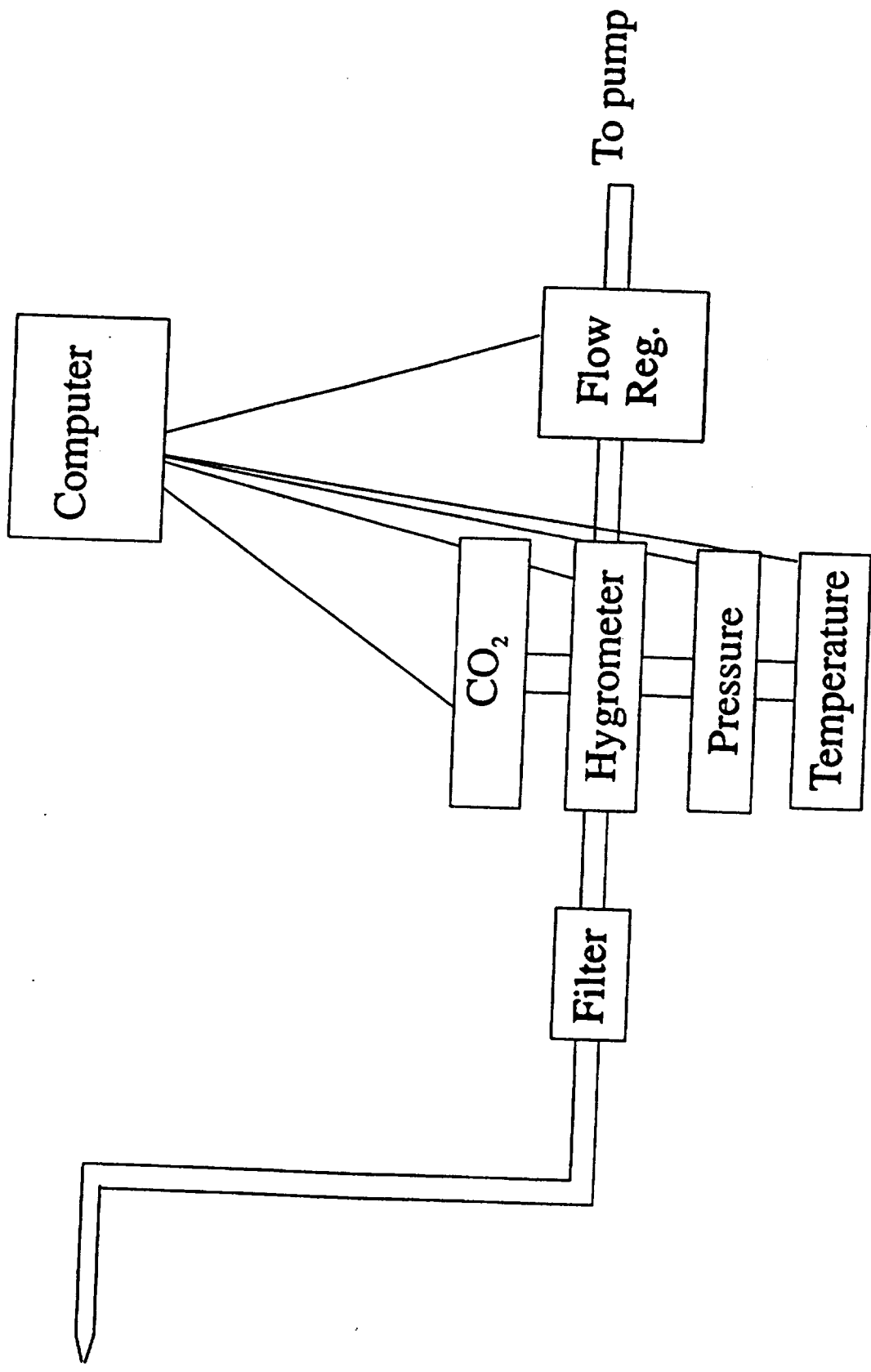

# Gas Phase Detection System



# Changes to F100 Engines affecting soot emissions

F100-100

F100-220

1. Improved axial swirler
2. Added more air

F100-229

High sheer swirler

# Emission indices for 4 F100-100 engines

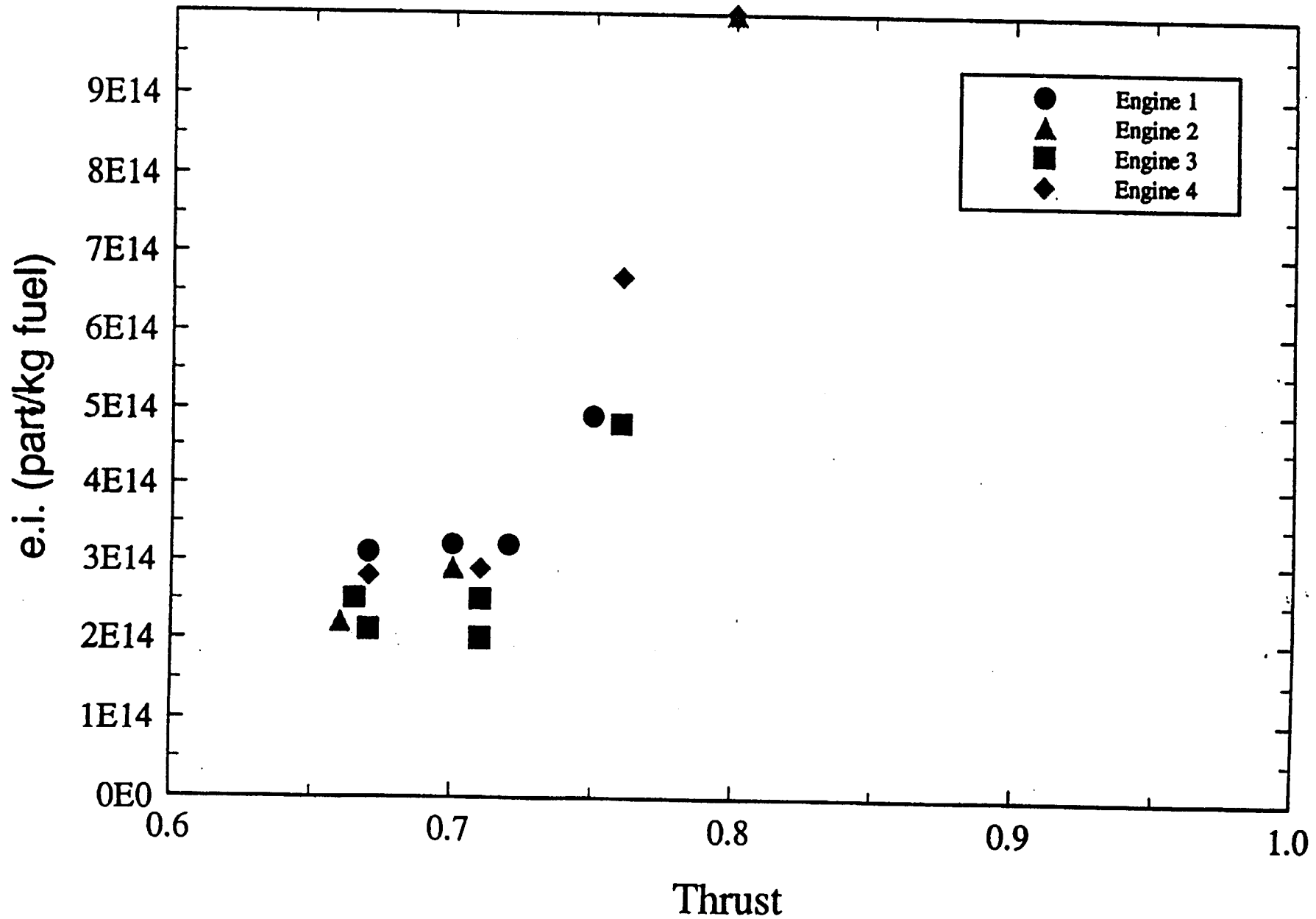

# Emission indices for 2 F100-220 engines

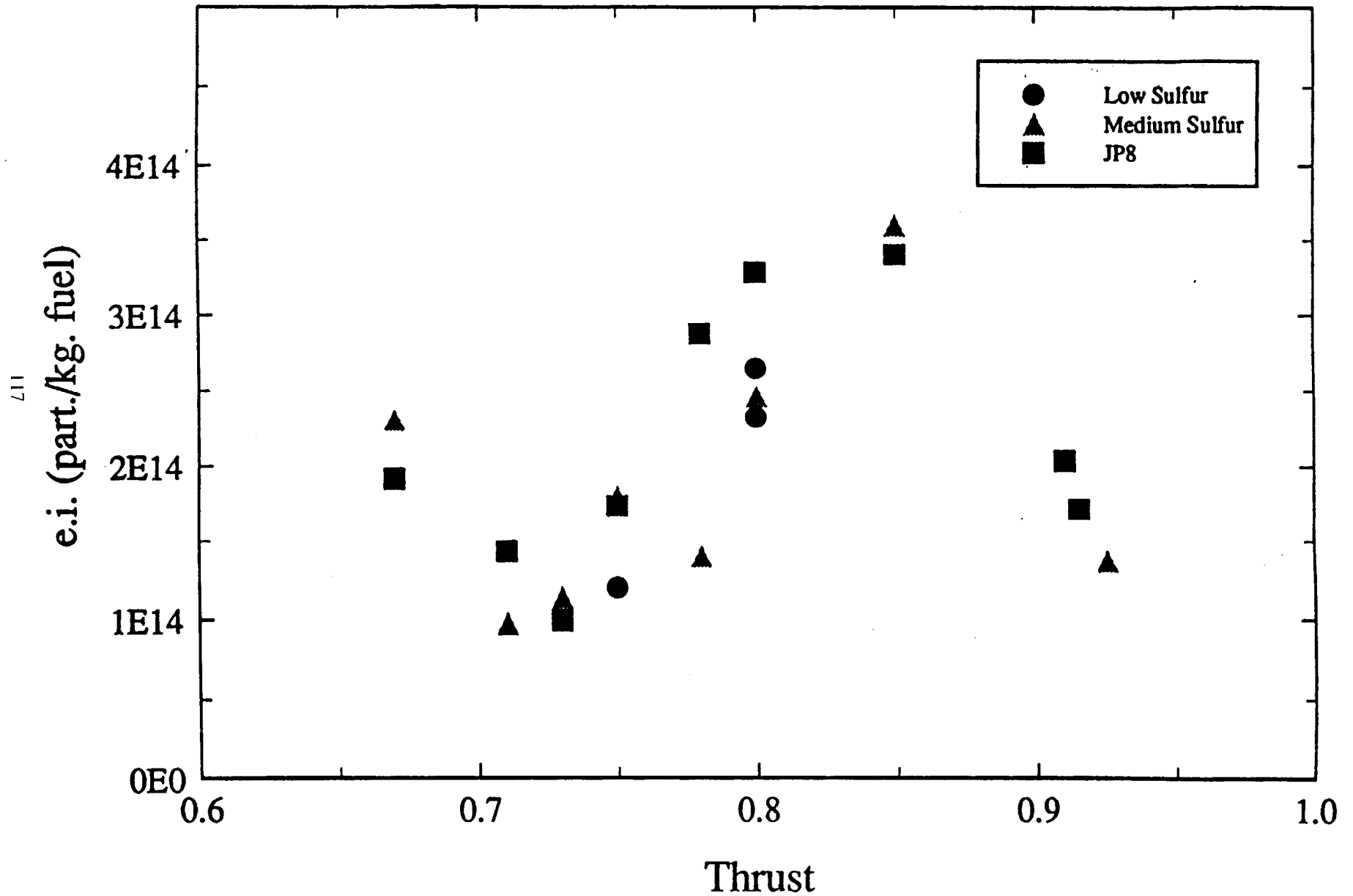

# Comparison of F100-100 and F100-220 series engines

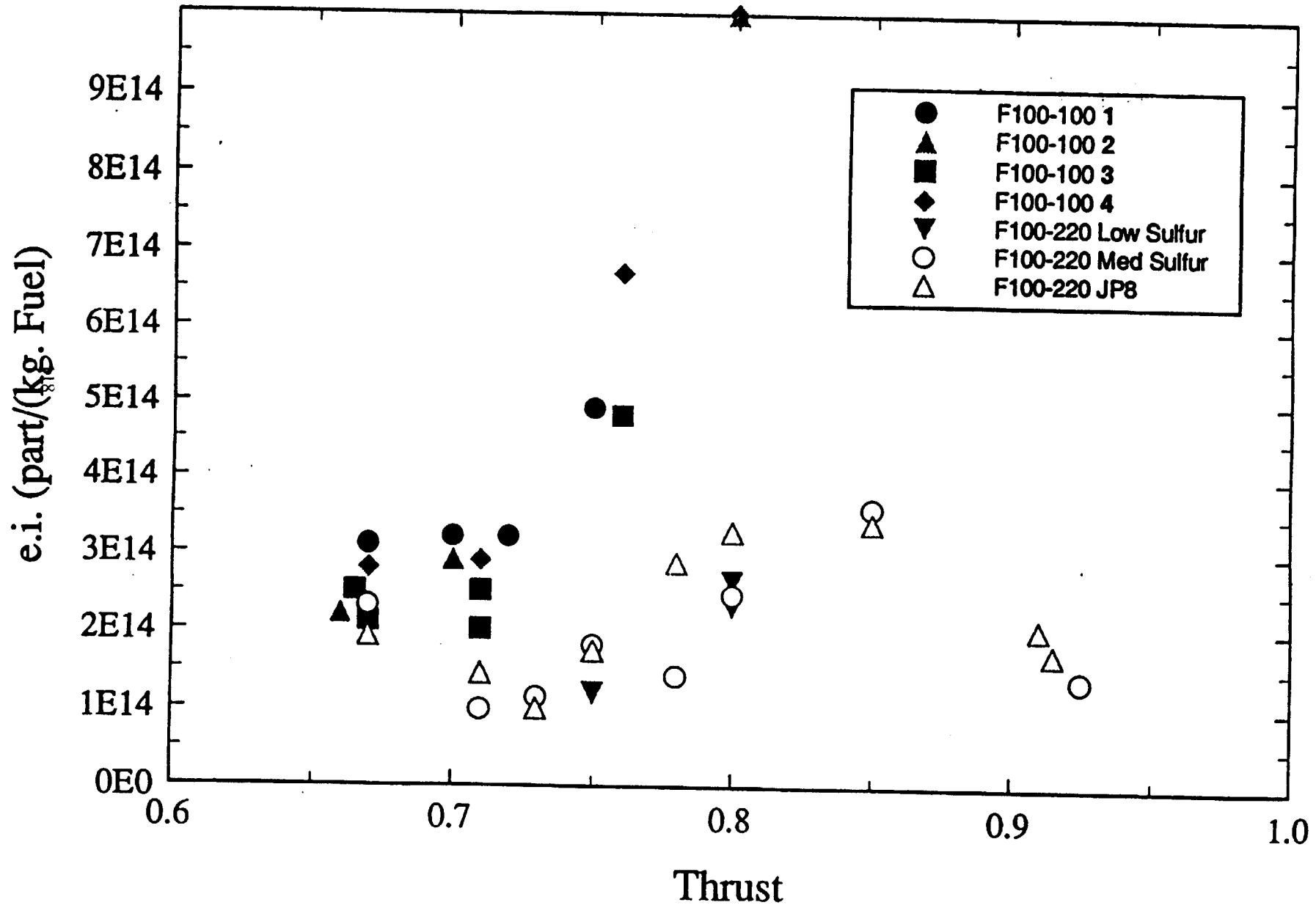

# Total Particle Emission Index vs CO<sub>2</sub>

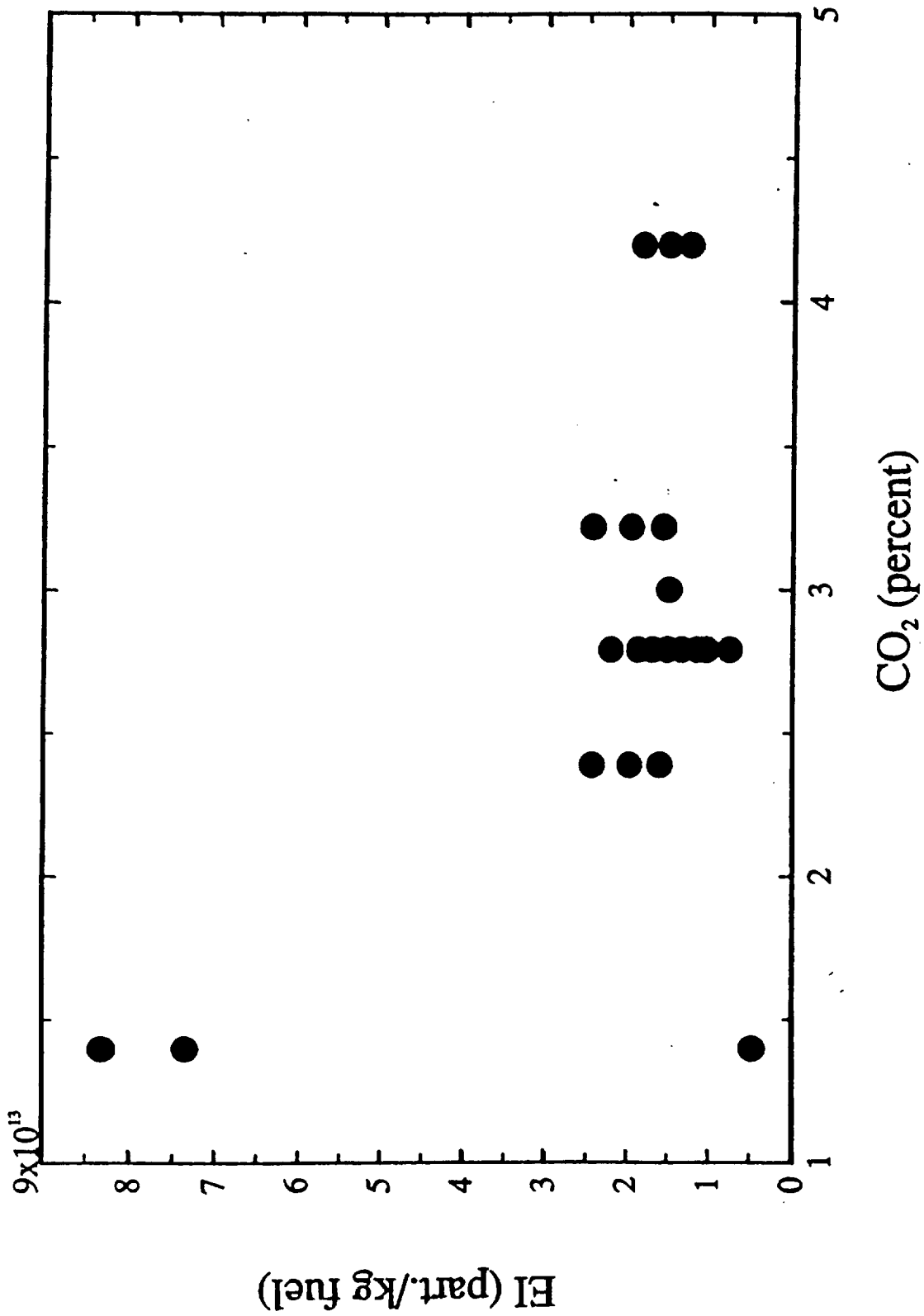

# Total Particle Emission Index vs Altitude

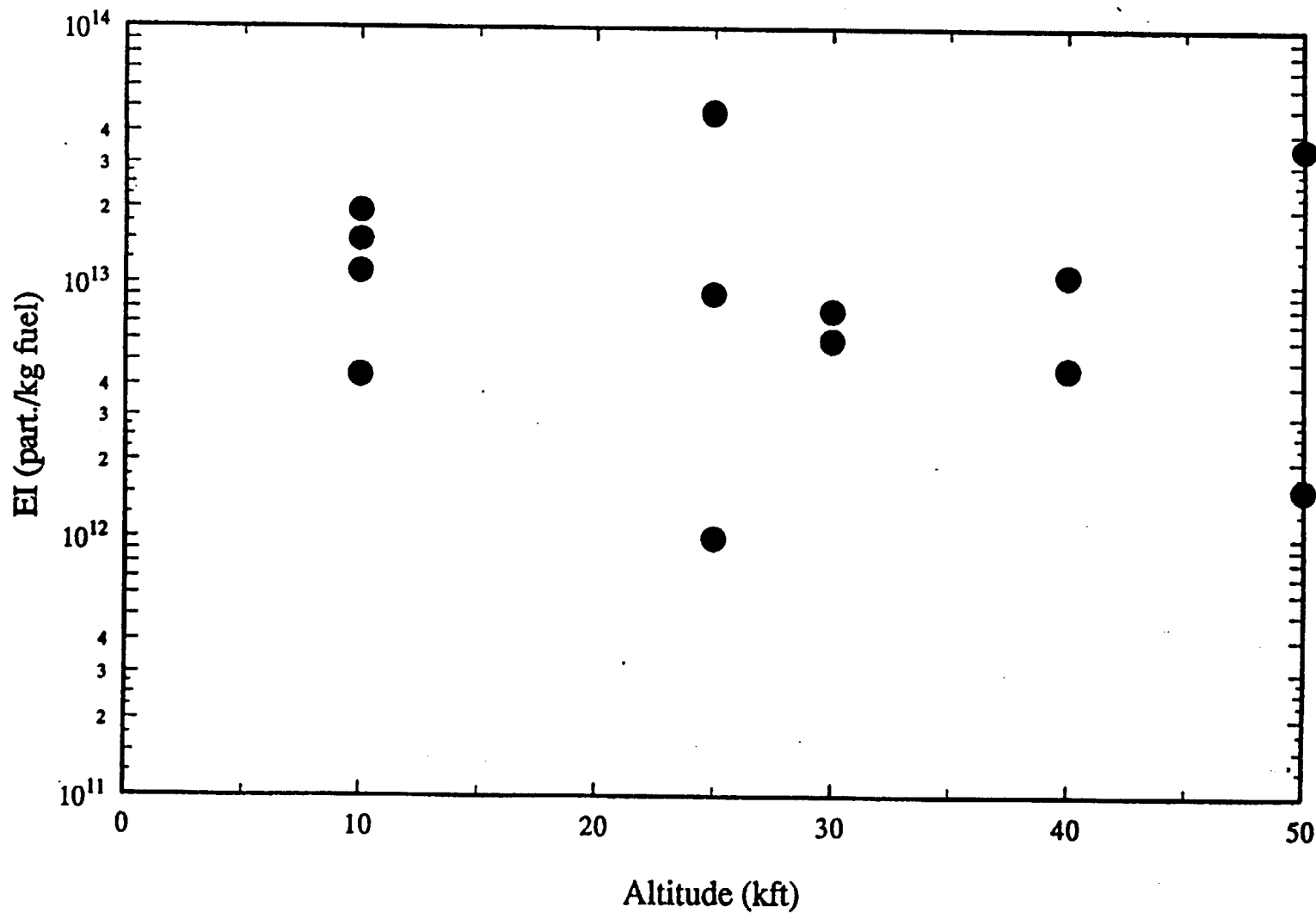

G72501.grf

Aerosol size distr,  
MO\_ANG, AEDC, NJ\_ANG

△	GC9
◇	156
○	009
□	010
△	011

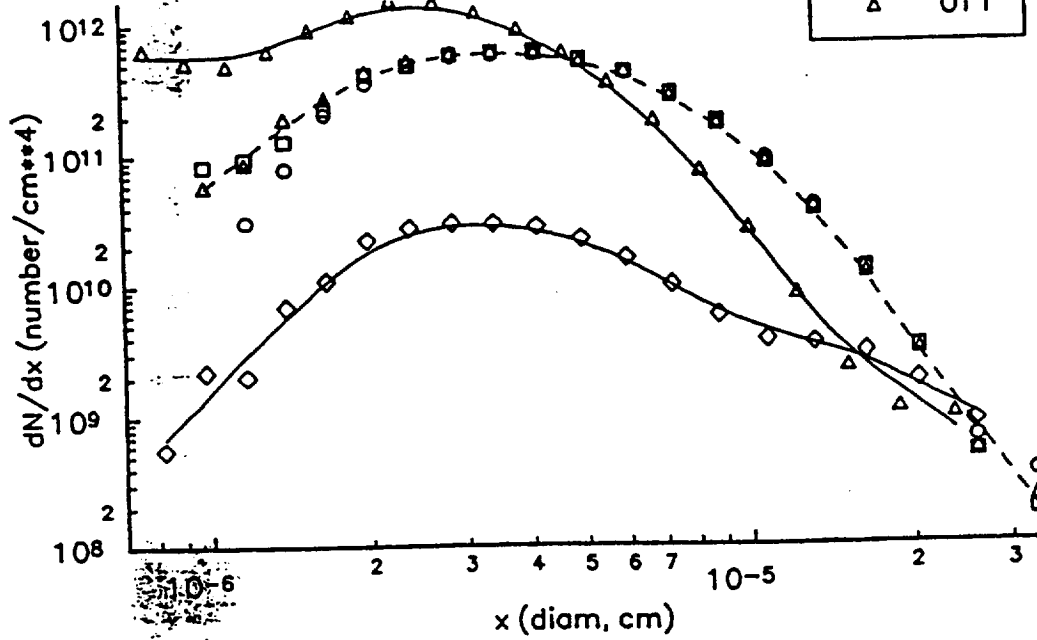

MO\_ANG, F100-100, gc9, 76%  
AEDC run 156, T3=733K, Alt=3.1 km (SLS), Time=14:57:00  
MO\_ANG, F100-220, 009,010,011, 80%





## ENGINE TEST AND MEASUREMENTS

Chowen Chou Wey  
NASA Glenn Research Center  
Cleveland, Ohio

Although the importance of aerosols and their precursors are now well recognized, the characterization of current subsonic engines for these emissions is far from complete. Furthermore, since the relationship of engine operating parameters to aerosol emissions is not known, extrapolation to untested and unbuilt engines necessarily remains highly uncertain.

1997 NASA LeRC engine test, as well as the parallel 1997 NASA LaRC flight measurement, attempts to address both issues by expanding measurements of aerosols and aerosol precursors with fuels containing different levels of fuel sulfur content. The specific objective of the 1997 engine test is to obtain a database of sulfur oxides emissions as well as the non-volatile particulate emission properties as a function of fuel sulfur and engine operating conditions.

Four diagnostic systems, extractive and non-intrusive (optical), will be assembled for the gaseous and particulate emissions characterization measurements study. NASA is responsible for the extractive gaseous emissions measurement system which contains an array of analyzers dedicated to examining the concentrations of specific gases (NO, NO<sub>x</sub>, CO, CO<sub>2</sub>, O<sub>2</sub>, THC, SO<sub>2</sub>) and the smoke number. University of Missouri-Rolla uses the Mobile Aerosol Sampling System to measure aerosol/particulate total concentration, size distribution, volatility and hydration property. Air Force Research Laboratory uses the Chemical Ionization Mass Spectrometer to measure SO<sub>2</sub>, SO<sub>3</sub>/H<sub>2</sub>SO<sub>4</sub>, and HNO<sub>3</sub>. Aerodyne Research, Inc. uses Infrared Tunable Diode Laser system to measure SO<sub>2</sub>, SO<sub>3</sub>, NO, H<sub>2</sub>O, and CO<sub>2</sub>.

## Objectives

- ▶ **Quantify engine gaseous and particulate emittants under sea-level and altitude conditions**
- ▶ **Verify, if possible, ICAO probe sampling procedures with independent non-intrusive sampling methods**
- ▶ **Determine NO, NO<sub>2</sub> pressure effects with changes in altitude**

## Measurement Techniques

- ▶ **Gaseous - Extractive Gas Sampling**
  - ▶ **NO, NO<sub>x</sub>: chemiluminescence (AEDC)**
  - ▶ **CO, CO<sub>2</sub>: nondispersive IR analyzers (AEDC)**
  - ▶ **O<sub>2</sub>: paramagnetic analyzer (AEDC)**
  - ▶ **THC: flame ionization detector (AEDC)**
  - ▶ **CO<sub>2</sub> : IR absorption (MDC)**
- ▶ **Gaseous - Optical Non-Intrusive**
  - ▶ **NO, OH: UV laser absorption (Sverdrup/AEDC)**
  - ▶ **NO, NO<sub>2</sub>, CO<sub>2</sub>, H<sub>2</sub>O: tunable diode laser absorption (ARI)**
- ▶ **Particulate - Extractive Gas Sampling**
  - ▶ **Smoke number - SAE smoke meter (Sverdrup/AEDC)**
  - ▶ **Total concentration, size distribution, hydration properties: mobile aerosol sampling system (UMR)**

## **Test Matrix**

- ▶ **Set point idle**
- ▶ **25,000 ft at three inlet temperature**
- ▶ **30,000 ft at three inlet temperature**
- ▶ **40,000 ft at three inlet temperature**
- ▶ **50,000 ft at three inlet temperature**
- ▶ **Sea-Level-Static -- ground idle 36%, 41%, 55%, and MIL PLA**

## Summary of Results

- ▶ All NO<sub>x</sub> data agreed within uncertainties of respective instruments
- ▶ Each optical measurement system produced precise and repeatable spectral data and predicted overall trends
- ▶ NO<sub>x</sub> levels agreed with prior engine test data -- where prior data available
- ▶ All CO<sub>2</sub> data agreed
- ▶ Particulate data showed that this is a very clean engine and there is no strong correlation between emission index and thrust, altitude, or combustor inlet temperature
- ▶ The results represent the first database of its kind to provide particulate characterization i.e. total and non-volatile concentration, total and non-volatile aerosol size distribution, and hydration property (soluble mass fraction) for a cruise simulation

## Objectives

- ▶ **Expand data base of engine gaseous and particulate emissions under sea-level and altitude conditions to small size engine**
- ▶ **Compare probe and non-intrusive measurements for NO, NO<sub>2</sub>, CO<sub>2</sub>**
- ▶ **Define particulate characteristics**
- ▶ **Obtain data for correlation of NO<sub>x</sub> from ground test to altitude conditions**
- ▶ **Define EPAP type parameter for G.A. engine**

## Measurement Techniques

- ▶ **Gaseous - Extractive Gas Sampling**
  - ▶ **NO, NO<sub>x</sub>: chemiluminescence (LeRC)**
  - ▶ **CO, CO<sub>2</sub>: nondispersive IR analyzers (LeRC)**
  - ▶ **O<sub>2</sub>: paramagnetic analyzer (LeRC)**
  - ▶ **THC: flame ionization detector (LeRC)**
- ▶ **Gaseous - Optical Non-Intrusive**
  - ▶ **NO, NO<sub>2</sub>, CO<sub>2</sub>, H<sub>2</sub>O: tunable diode laser absorption (ARI)**
- ▶ **Particulate - Extractive Gas Sampling**
  - ▶ **Smoke number - SAE smoke meter (LeRC)**
  - ▶ **Total concentration, size distribution, hydration property: mobile aerosol sampling system (UMR)**
  - ▶ **Total concentration, size distribution: particle analyzer (LeRC)**

## **Test Matrix**

- ▶ **10,000 ft at two inlet temperature**
- ▶ **15,000 ft at five inlet temperature**
- ▶ **25,000 ft at four inlet temperature**
- ▶ **30,000 ft at two inlet temperature**
- ▶ **40,000 ft at four inlet temperature**
- ▶ **50,000 ft at four inlet temperature**
- ▶ **65,000 ft at two inlet temperature**
- ▶ **Sea-Level-Static at six inlet temperature**



## **Summary of Results**

- ▶ **All NO<sub>x</sub> data agreed within uncertainties of respective instruments**
- ▶ **Optical measurement system produced precise and repeatable spectral data and predicted overall trends**
- ▶ **Particulate data showed that this is a clean engine and there is correlation between emission index and thrust, altitude, or combustor inlet temperature**
- ▶ **The results expand the database of its kind to small size engine**

## Objectives

- ▶ **Quantify engine gaseous and particulate emittants, including SO<sub>2</sub>, SO<sub>3</sub>/H<sub>2</sub>SO<sub>4</sub> for the first time, under sea-level and altitude conditions for different jet fuels**
- ▶ **Define the effects of fuel sulfur level on SO<sub>2</sub>, SO<sub>3</sub>/H<sub>2</sub>SO<sub>4</sub> and particulate characteristics**
- ▶ **Compare probe and non-intrusive measurements for NO, NO<sub>2</sub>, CO<sub>2</sub>, SO<sub>2</sub>, SO<sub>3</sub>**
- ▶ **Data to be used as a comparative baseline with flight measurements**

## Measurement Techniques

- ▶ **Gaseous - Extractive Gas Sampling**
  - ▶ **NO, NO<sub>x</sub>: chemiluminescence (LeRC)**
  - ▶ **CO, CO<sub>2</sub>: nondispersive IR analyzers (LeRC)**
  - ▶ **O<sub>2</sub>: paramagnetic analyzer (LeRC)**
  - ▶ **THC: flame ionization detector (LeRC)**
  - ▶ **SO<sub>2</sub>: UV Fluorescence (LeRC)**
  - ▶ **SO<sub>2</sub>, SO<sub>3</sub>/H<sub>2</sub>SO<sub>4</sub>: mass spectrometer (AF/PL)**
- ▶ **Gaseous - Optical Non-Intrusive**
  - ▶ **NO, NO<sub>2</sub>, CO<sub>2</sub>, H<sub>2</sub>O, SO<sub>2</sub>, SO<sub>3</sub>: tunable diode laser absorption (ARI)**
- ▶ **Particulate - Extractive Gas Sampling**
  - ▶ **Smoke number - SAE smoke meter (LeRC)**
  - ▶ **Total concentration, size distribution, hydration property: mobile aerosol sampling system (UMR)**

## **Test Plan**

- ▶ **Simulated Altitude**
  - ▶ **30,000 ft at five inlet temperature**
  - ▶ **40,000 ft at five inlet temperature**
  - ▶ **55,000 ft at four inlet temperature**
  - ▶ **Sea-Level-Static at six inlet temperature**
  - ▶ **Higher altitude ?**
- ▶ **Fuel**
  - ▶ **Low Sulfur Jet A with anti-corrosion additive**
  - ▶ **High Sulfur Jet A with anti-corrosion additive**
  - ▶ **JP8+100**
  - ▶ **Medium Sulfur Jet A ?**

## HOT SECTION MODELING

Ian A. Waitz and S.P. Lukachko  
MIT Aero-Environmental Research Laboratory  
Cambridge, Massachusetts

and

Richard C. Miake-Lye, Robert C. Brown,  
and Mark R. Anderson  
Aerodyne Research Inc.  
Billerica, Massachusetts

Many aircraft engine exhaust species that may perturb the atmosphere exist in trace amounts. These species can be transformed by chemical reaction within the engine prior to emission into the atmosphere. To better understand the role of intra-engine processes in determining the final composition of engine exhaust, a flow-chemistry model was developed over the last three years through a collaboration between the Massachusetts Institute of Technology (MIT) and Aerodyne Research, Inc. (ARI). This computational approach was used to investigate chemical processes that occur through the turbine and exhaust nozzle by simulating the post-combustor flow path over a range of physical representations, from simplified, homogenous cases to situations that incorporate complex fluid mechanics more typical of a modern aircraft turbine.

Using a chemistry model that includes  $\text{HO}_x$ ,  $\text{NO}_y$ ,  $\text{SO}_x$ , and  $\text{CO}_x$  reactions developed through the work of Robert C. Brown of ARI and Fred L. Dryer of Princeton University, several 1-D parametric analyses were conducted for the entire turbine and exhaust nozzle flowpath of a typical advanced subsonic engine to understand the effects of important flow and chemistry variations on species evolution in general, and the development of volatile aerosol precursors in particular. These studies highlighted the sensitivity of exhaust composition to the trace species concentrations specified at the combustor exit, mass addition within the turbine, and combustor exit temperature. Representative 2-D, single turbine blade row simulations were also performed to determine the potential impact of flow nonuniformities that cannot be captured directly or modeled simply through 1-D analyses. Temperature nonuniformities that result from the use of an internal blade cooling strategy were investigated and revealed a significant impact in  $\text{SO}_x$  chemistry. Comparisons of 1-D approximations to the 2-D turbine solutions were then carried out to help determine the extent to which current 1-D modeling capabilities can resolve changes in chemical composition. The results call into question the validity of 1-

D averaged flow analysis for the highly-nonuniform, unsteady flow fields of the turbine and exhaust nozzle.

Suggestions for future work to be carried out within the AEAP include:

1. Conduct complementary numerical analyses and laboratory and/or engine test cell experiments both to acquire data regarding trace species emissions, and to provide a mechanism for validating numerical tools.
2. Develop valid kinetic models for trace species chemistry within the intra-engine environment (combustor dilution zone, turbine, and exhaust nozzle).
3. Perform numerical investigations to identify and understand key fluid mechanical effects in 1-D, 2-D and 3-D turbine and nozzle geometries.
4. Improve computational mechanics and code usability to allow more realistic situations to be modeled, both for understanding the relevant physics and chemistry, and for supporting flight and ground-based engine tests.
5. Develop accurate, simplified models of intra-engine trace chemical processes that may be used in lieu of complex three-dimensional, multi-blade row simulations, to provide estimates of the trace emissions constituents of current and future engines.
6. Extend the range of intra-engine chemistry modeling to include the combustor, both for defining relevant inputs for turbine and nozzle modeling efforts, and for discovering possible impacts of combustion processes on volatile aerosol formation.

## Outline of Presentation

- Current status of turbine and exhaust nozzle flow-chemistry modeling
- Future research directions / needs
  - Investigate aerosol precursor turbine flow field effects
  - Develop valid kinetic models for intra-engine environment
  - Improve computational capabilities
  - Continue validation of numerical tools
  - Develop accurate simplified models of intra-engine processes
  - Measure / model trace species chemistry in combustor

## Requirements for Hot Section Modeling

- Significant atmospheric effects dependent on details of trace species chemistry
  - e.g.  $\text{NO}_y$ - $\text{NO}_x$ ,  $\text{SO}_x$ ,  $\text{HO}_x$ : concentrations range from 0.0001 - 0.1 ppmv
- Evolution of many trace species poorly understood
- Trace species undergo considerable change through turbine and exhaust nozzle
- Turbine and exhaust nozzle flow and chemistry are complex and pose many theoretical / modeling challenges
- All previous research treated turbine and nozzle as either:
  - infinitely thin: combustor exit speciation = nozzle exit speciation
  - 1-D: kinetic change through averaged temperature, pressure, velocities based on minimal interpolation between combustor and nozzle



# Turbine and Exhaust Nozzle Chemistry

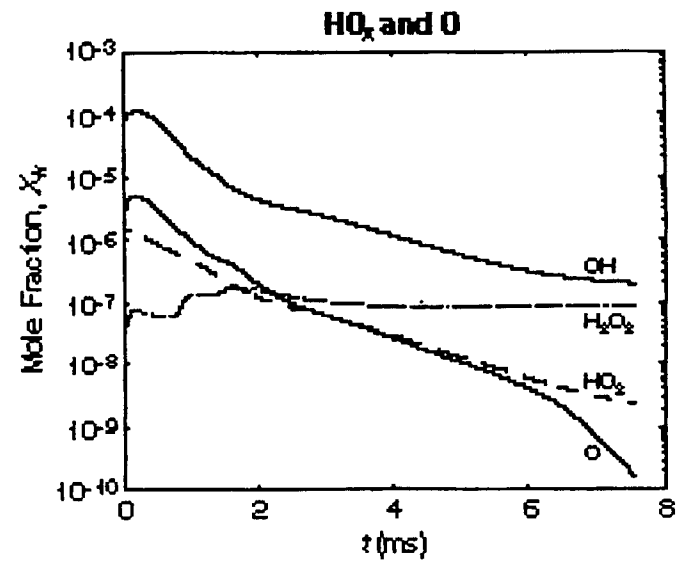
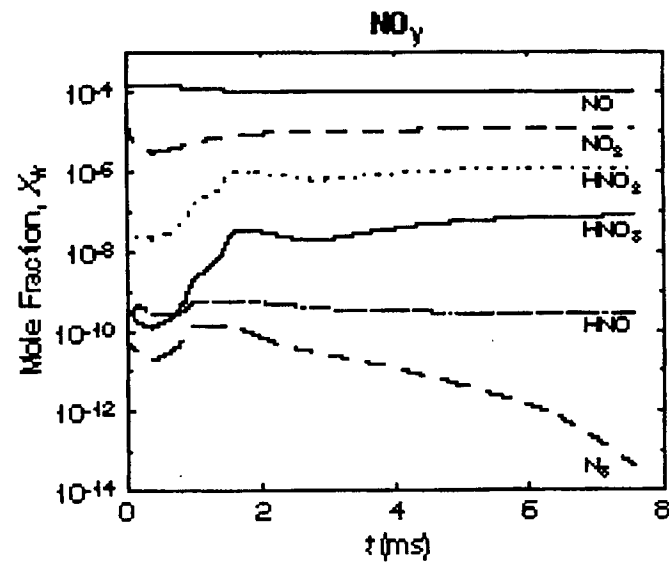
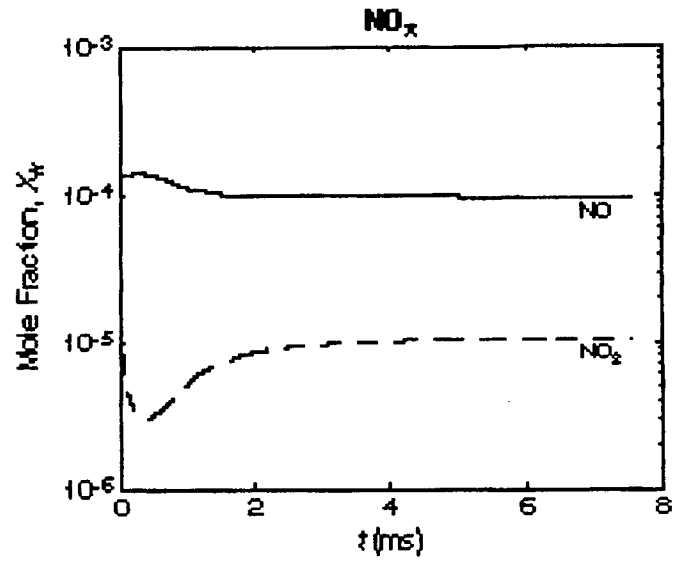
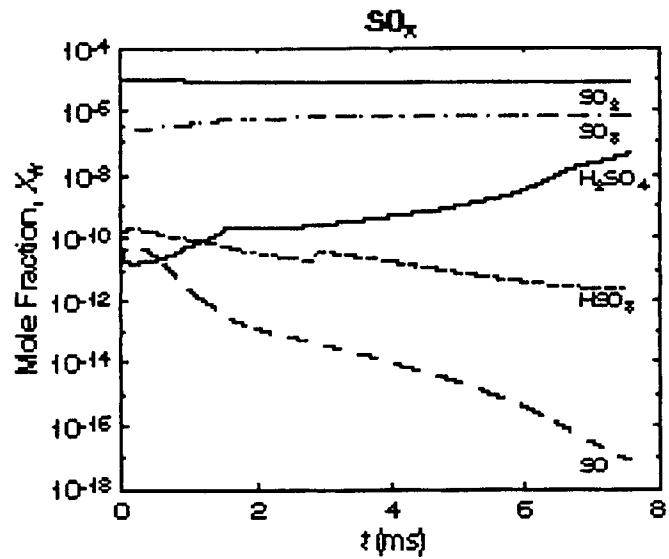

# Turbine Chemistry Modeling Challenges

- Complex, 3-D, unsteady flow field
- Multiple stages
- Complex inlet and boundary conditions
- 25+ species, 70+ passive chemical reactions
- Small concentrations (ppm to ppt) can result in significant atmospheric impact

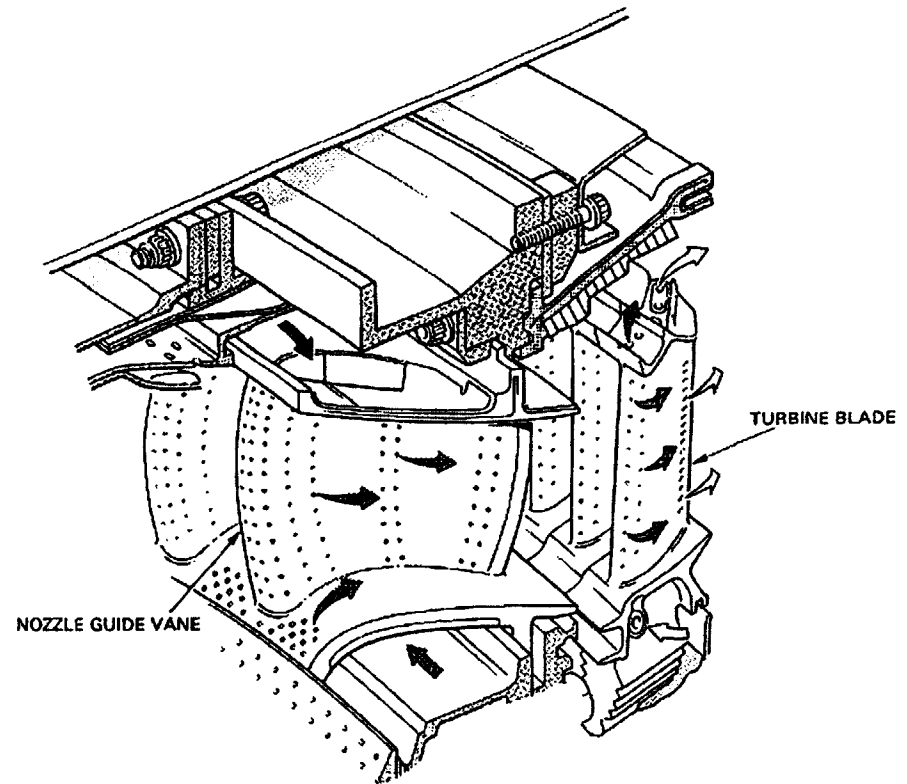

Source: Adapted from  
Rolls-Royce, 1986

## Useful Modeling Tool Developed

- First 1-D, 2-D, 3-D modeling tool for turbine and nozzle chemistry developed
- Limited numerical validation
  - self-consistency
- Limited applications
  - kinetics, geometry, and flow conditions
- Computationally intensive

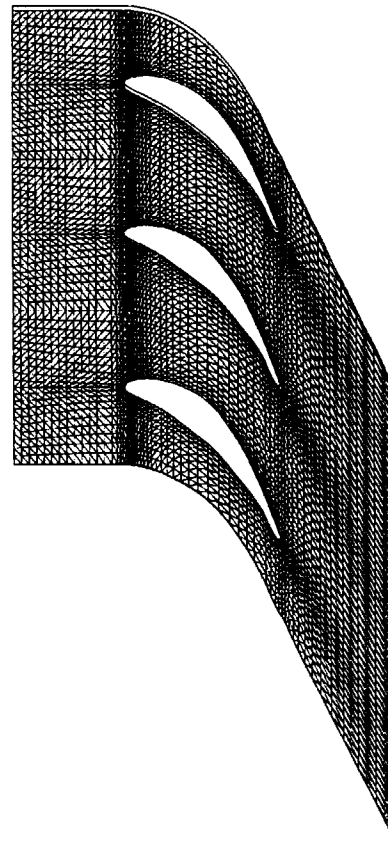

**2-D Grid**

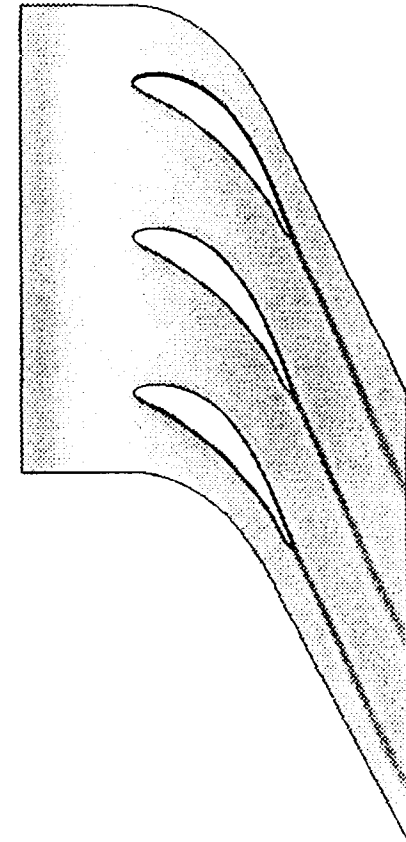

**OH Distribution**

## Current Status of Understanding

- Results suggest 1-D modeling insufficient to accurately capture some trace species evolution
  - Errors of two orders of magnitude observed for some species over single blade row
  - 2-D / 3-D fluid mechanical effects play critical role

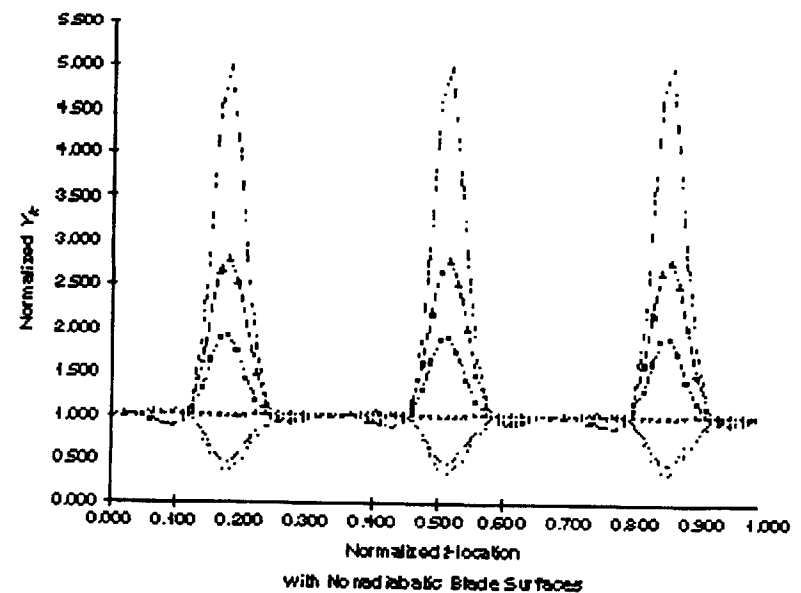
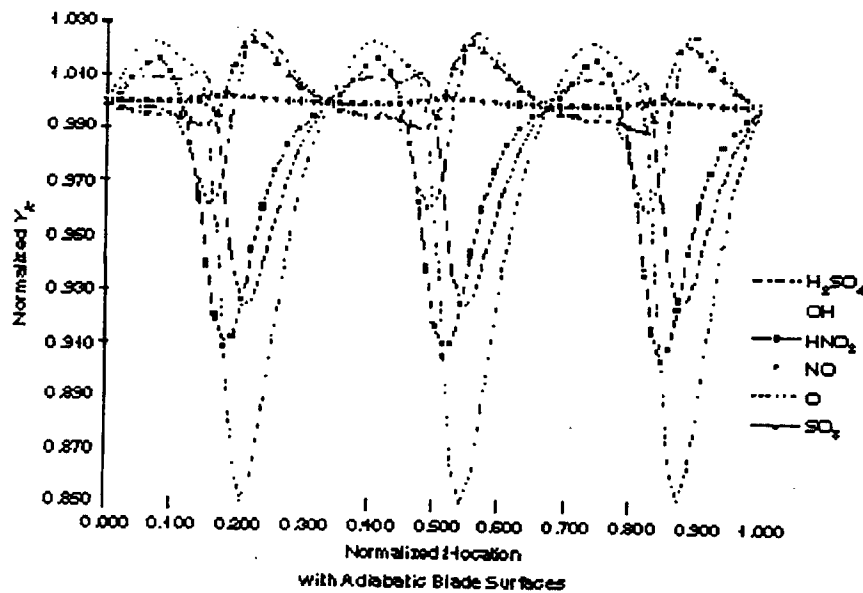

## Current Status of Understanding

- Temperature gradients associated with blade cooling possible enhance  $\text{SO}_2$  to  $\text{SO}_3$  oxidation
- For first time, strong role for turbine in pollution formation /control suggested

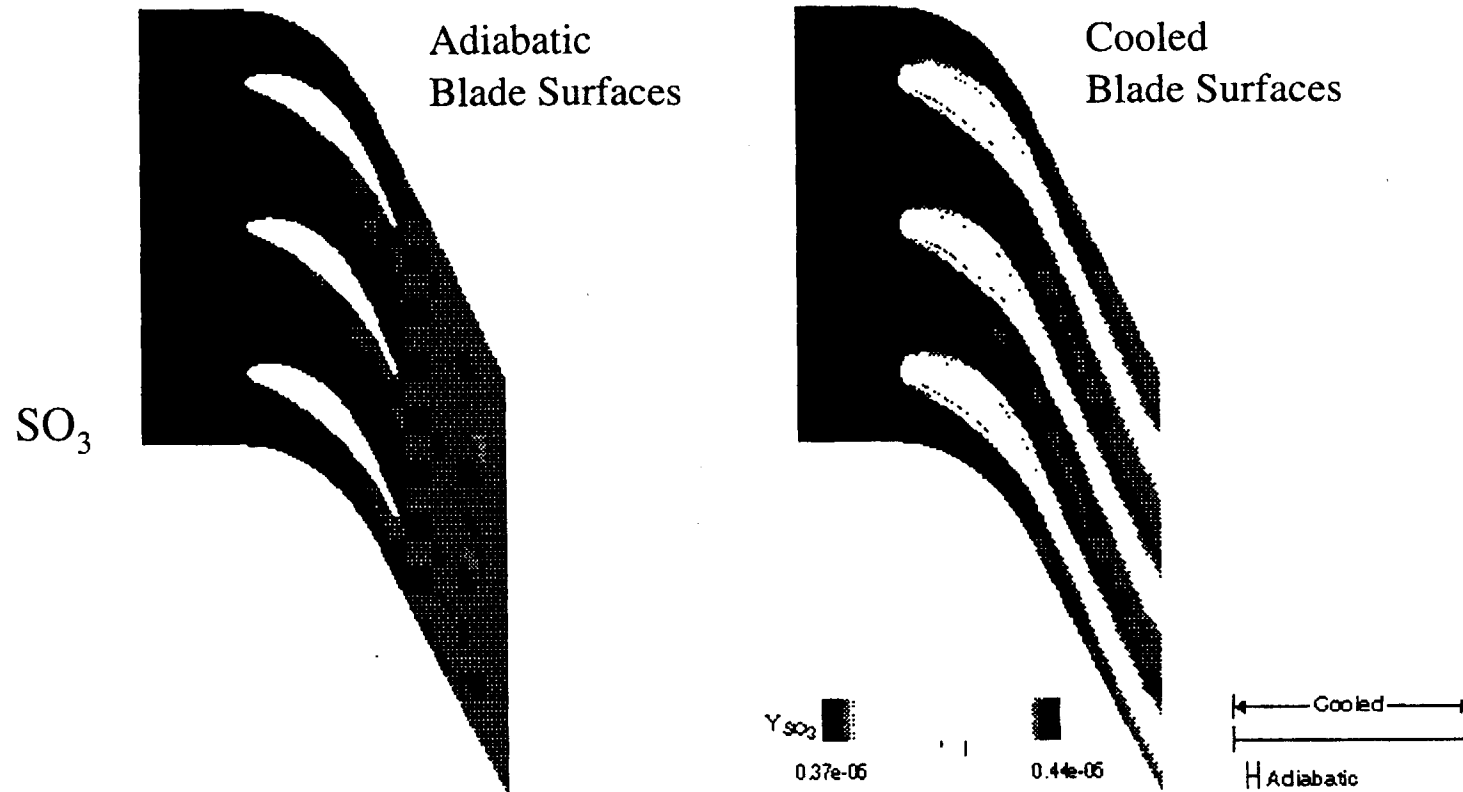

## Future Research Directions / Needs

Issue 1.

Investigate aerosol precursor turbine flow field effects.

# Flow Field Effects and Aerosol Precursor Chemistry

- Large number of fine aerosols observed
  - may have significant atmospheric effects
- Predictions and measurements vary widely
  - plume / wake models do not indicate extensive oxidation
  - 1-D models for turbine and exhaust nozzle indicate limited oxidation

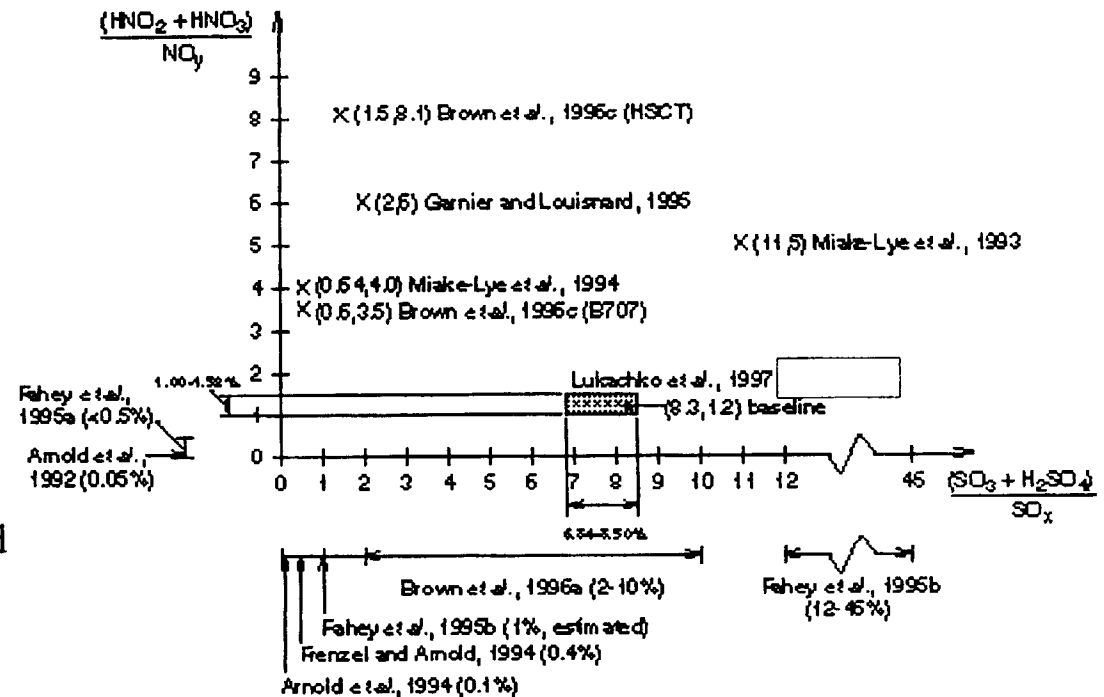

- 2-D / 3-D models suggest more oxidation—temperature gradients
  - one specific geometry, cycle, temperature, reaction set for limited phenomena
- Understanding of aerosol precursor chemistry far from what required for assessments

# Flow Field Effects and Aerosol Precursor Chemistry

- Objectives

- continue to evaluate effects of fluid mechanical phenomena on the evolution of  $\text{SO}_x$ ,  $\text{NO}_y$ , and  $\text{HO}_x$  chemistry
- isolate important phenomena and requirements for adequate modeling of entire chemical scheme—interactions among chemical families important
- analyze ground level and *in-situ* exhaust data

- Approach

- evolve 2-D / 3-D calculations to encompass wider diversity of flow situations and geometrical specifications
  - implement well-resolved 2-D / 3-D single blade-row flow-chemistry calculations
  - conduct multiple blade row calculations
  - incorporate unsteady effects via boundary conditions
- conduct further single parameter or combined 1-D calculations to investigate influences of additional averaged-flow perturbations
  - cooling flows, different cycles (technology) , operational effects, blade-row - resolved profiles



## Future Research Directions / Needs

Issue 2.

Develop valid kinetic models for intra-engine environment.

## Development of Valid Kinetic Models

- Kinetic models are not validated
  - range of temperatures and pressures in turbine and exhaust nozzle large
  - range of parameters unfamiliar to both combustion and atmospheric chemistry
    - alternative rate parameters for reactions in current mechanism
  - some important oxidation routes may not be included
    - sulfur oxidation via  $\text{SO}_4$  intermediary (ARI)
    - $\text{SO}_2$ ,  $\text{NO}_y$  uptake on soot particles (ARI)
    - combustor exit ionic concentrations persist through engine (ARI)
    - alternative sulfur, carbon mechanisms (Dryer, Princeton)
    - catalysis on hot engine surfaces, trace metals in exhaust
- Trace species sensitive to boundary conditions as well as local temperatures and pressures
  - sensitivities and thus results will change with different models

# Development of Kinetic Models

- Objectives

- produce and evaluate several viable kinetic models using mechanisms validated for proper ranges
- evaluate and recommend set of species, gaseous reactions, and heterogeneous processes for standard model

- Approach

- perform analyses of reaction influence coefficients at various points in flow field for 1-D and/or 2-D/3-D calculations
- implement sensitivity analyses for rate parameters
- conduct computational experiments to confirm influential reactions
- conduct validations using experimental-computational comparisons for simple cases via CNEWT
  - 1-D reactor (Dryer) and/or 2-D/3-D single blade-row geometries
- laboratory experimental support to fill gaps in knowledge base

## Future Research Directions / Needs

Issue 3.

Improve computational capabilities of numerical tools.

## Improved Computational Capabilities

- Expensive, complex 3-D multiple blade row calculations may be required to simulate relevant fluid / chemical effects
  - without chemistry, 3-D single blade row approachable using coarse, Euler-type grid
  - with chemistry, 3-D single blade row unmanageable without efficiency, capacity boosts
- Potential integration with engine design support systems (*e.g.* NPSS) requires improved interface and code structure
- Additional capabilities required to evaluate range of possible fluid phenomena and chemical mechanisms

151

Current Implementations	Calculation Statistics
IBM RISC-based Power Servers (AIX)	>70% cpu time spent on chemistry
DEC Alpha Servers (OSF-1, Digital UNIX)	typically 40-150 MB for 2-D turbine grid
SGI Iris and Indigo II workstations (IRIX)	25 sec/iteration on Alpha Server 2100/275
HP workstations (HP-UX)	typically 4000-6000 iterations to converge

# Improved Computational Capabilities

- Objectives
  - establish means through which to conduct calculations at next level of detail (3-D steady, 2-D multiple blade row)
  - respond to needs of various customers in engineering and scientific communities
- Approach
  - update algorithms for efficiency, improve code structure for modularity
  - implement parallelization
    - parallelizing compilers, code structural changes—message passing routines
    - parallelize nodal chemistry calculation first, fluid routines if required
  - add / improve several current capabilities, establish best practice uses
    - higher order boundary conditions, assumptions for constants
    - integrate improved unstructured grid generator
  - incorporate uncertainty analysis techniques
  - improve documentation and implement a basic UI/GUI

## Future Research Directions / Needs

Issue 4.

Continue validation of numerical tools.

# Validation of Numerical Tools

- Validation has consisted of limited self-consistency checks
  - using simple geometries in order to simplify flow situations to well understood cases
- No experimental comparisons have been made to validate code in practical situations
  - availability of experimental information limited
  - code useful for analyzing trends, predictive capabilities not assessed
- Only basic understanding of code accuracy limitations and relation to application-oriented accuracy requirements

Euler-type simple grids

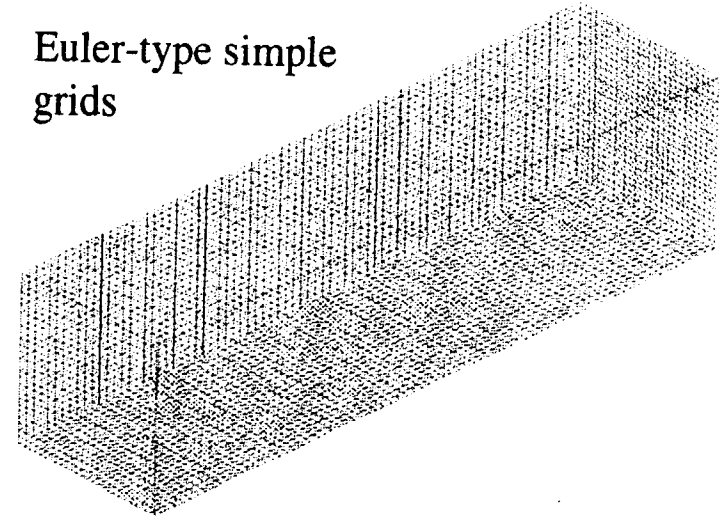

More refined simple grids

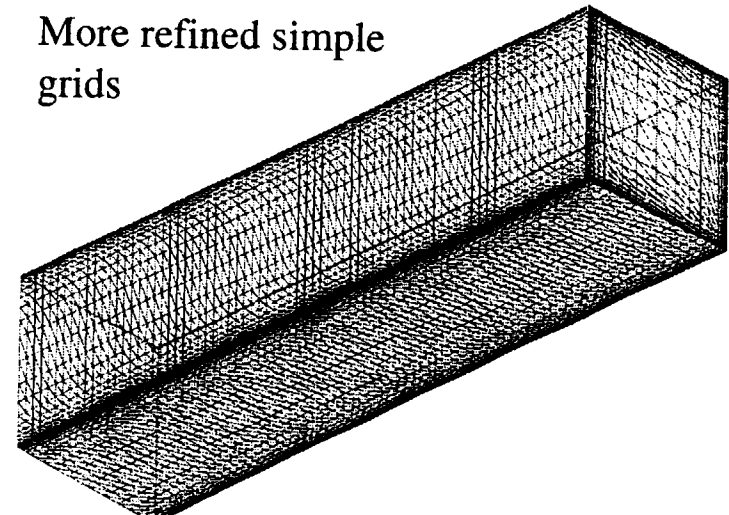



# Validation of Numerical Tools

- Objectives

- continue validation to gain better understanding of code accuracy
- analyze requirements as they relate to assessment needs for downstream modelers, for useful design decisions

- Approach

- continue self-consistency checks using simple geometries
  - assure basic functions operate satisfactorily
  - identify needs for algorithmic improvement
- conduct comparisons of computational results to experimental results to address predictive needs
  - 1-D reactor (Dryer) and/or 2-D/3-D single blade-row laboratory setups
  - information from combustor rig and full-scale engine tests (ground , altitude condition), preferably with cycle information and relevant 1-D, 2-D, and/or 3-D geometrical data for post-combustor flow path
- use 1-D results as input to representative plume/wake calculation

## Future Research Directions / Needs

Issue 5.

Develop accurate simplified models of intra-engine processes.

## Development of Accurate Simplified Models

- Results have indicated that 1-D models are insufficient in current form to adequately predict all chemical changes

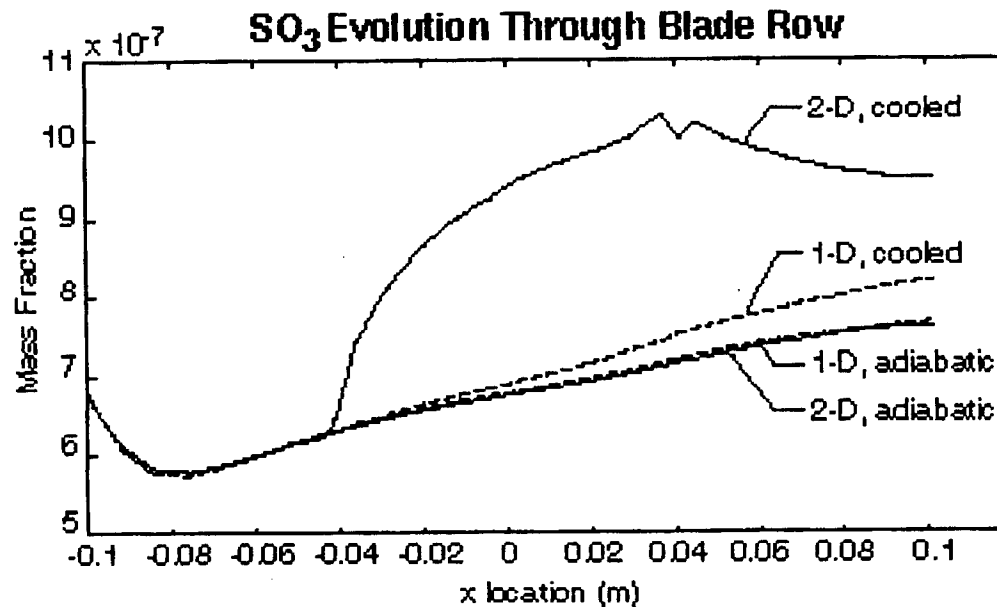

- 3-D solutions are not universally attainable because of limited computational resources
- Practical applications of computational models may require simplifications and computational approximations

## Development of Accurate Simplified Models

- Objective
  - determine whether or not simplified 1-D and / or 2-D models can be developed that simulate 3-D complex turbine flows
  - organize possible simplifications towards possible integration with current NPSS strategies
- Approach
  - many of same steps required of further investigations of turbine flow-field effects also apply here
    - evolve 2-D / 3-D calculations to encompass wider diversity of flow situations and geometrical specifications
    - conduct further single parameter or combined 1-D calculations to investigate influences of additional averaged-flow perturbations
  - extra steps: incorporating experimental data and integrating information available via higher-order simulations into lower-order simulations
    - novel averaging techniques, empirical corrections, theoretical simplifications

## Future Research Directions / Needs

Issue 6.

Measure / model trace species chemistry in combustor.

# Understanding Trace Species in Combustor

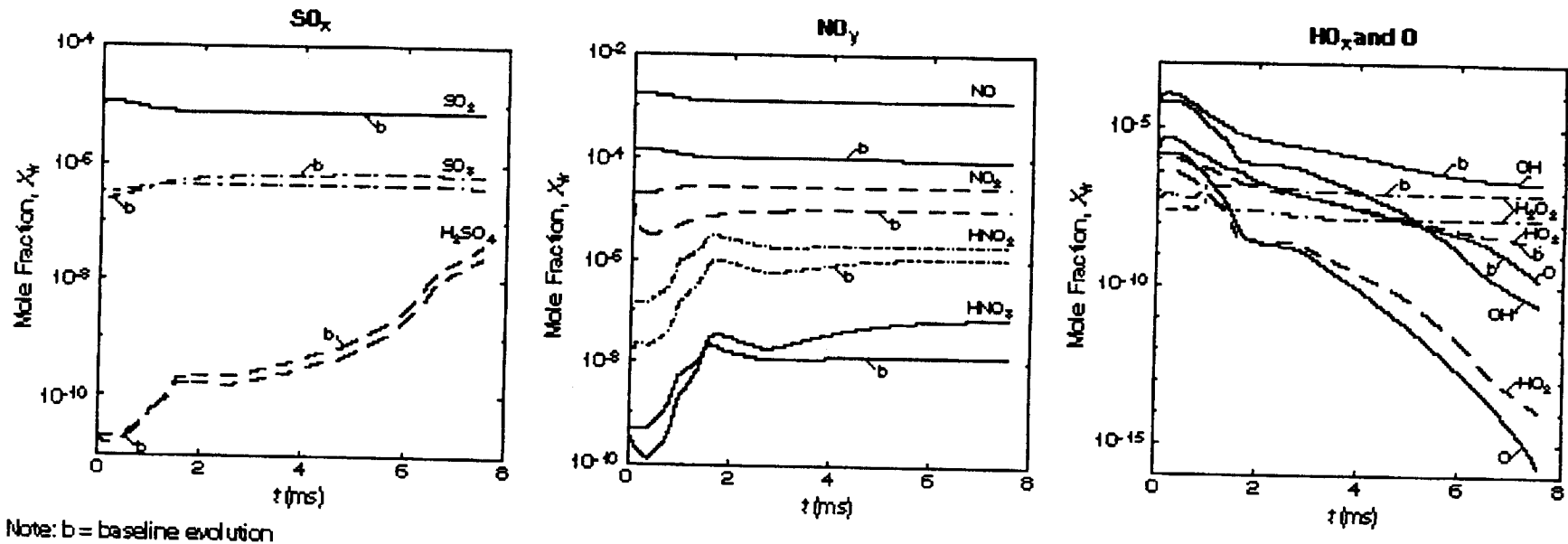

- Solutions obtained sensitive to initializations
  - particularly to equilibrium or nonequilibrium concentration assumptions
- Present combustor exit initializations ad hoc
  - no current understanding of combustor trace species at combustor exit
  - based on assumptions about emission indices, fuel content, important species
  - first-order estimates not internally consistent

# Understanding Trace Species in Combustor

- Objectives

- understand content and distribution of species at combustor exit plane to allow accurate turbine simulation, especially for trace species
- investigate early sulfur, nitrogen oxidation potential within combustor dilution zones

- Approach

- obtain experimental and / or CFD information for combustor exit plane
  - temperature, pressure, velocity, species distributions
  - measurements from simple reactors and / or complete combustor rig at combustor exit plane
- formulate mechanistic basis for inlet / initial conditions
  - based on combustor calculation—simplified or complex CFD—for combustor exit plane results
  - CFD must incorporate trace species for full extent of combustor
- possible support with development of intra-engine diagnostic instrumentation for trace species (ARI)

## Research on Intra-Engine Chemistry: Future Directions Summary

- Aircraft atmospheric effects in general, turbine/nozzle role in particular, growing in importance
  - *e.g.* sulfur issue
  - only one research effort worldwide addressing these issues
- Developed first capability for 1-D, 2-D, 3-D numerical modeling of chemistry in turbine and nozzle
  - only preliminary applications thus far
  - important for understanding results from future measurement campaigns
  - results to date suggest many critical areas for future work



CHARGE TO WORKING GROUPS

Sol Gorland and Martin Rabinowitz  
NASA Glenn Research Center  
Cleveland, Ohio

## TRACE CHEMISTRY

*KRISHNAN RADHAKRISHNAN*

*PHILLIP WHITEFIELD*

## INSTRUMENTATION

*MICHELLE ZALLER*

*RICHARD MIAKE-LYE*

## VENUES & PROCEDURES

*PETER PACHLHOFER*

*ROBERT HOWARD*

INTEGRATE SPECIAL NEEDS

PROBES & PLUMBING

STANDARDIZATION

PIGGYBACKING

# TRACE CHEMISTRY

*KRISHNAN RADHAKRISHNAN*

*PHILLIP WHITEFIELD*

# INSTRUMENTATION

*MICHELLE ZALLER*

*RICHARD MIAKE-LYE*

# **VENUES & PROCEDURES**

*PETER PACHLHOFER*

*ROBERT HOWARD*

INDUSTRY PERSPECTIVE ON INSTRUMENTATION

*RICHARD STRANGE*

SPECIES AND CONCENTRATIONS

*MICHELLE ZALLER*

THE AEROSOL PRECURSOR PROBLEM

*RICHARD MIAKE-LYE*

MICROFINE PARTICLE ANALYSIS AND GENERATION

*DAVID PUI*

ABSORPTION SPECTROSCOPY

*DANIEL OH*

EMISSION SPECTROSCOPY

*MICHAEL WINTER*



# TRACE CHEMISTRY

*KRISHNAN RADHAKRISHNAN*

*PHILLIP WHITEFIELD*

# **INSTRUMENTATION**

*MICHELLE ZALLER*

*RICHARD MIAKE-LYE*

# VENUES & PROCEDURES

*PETER PACHLHOFER*

*ROBERT HOWARD*

SOOT

# INTERACTIONS:

O HO<sub>X</sub> C<sub>X</sub>H<sub>Y</sub> NO<sub>X</sub>



# The spin-forbidden dissociation-recombination reaction

## $\text{SO}_3 \rightleftharpoons \text{SO}_2 + \text{O}$

D. C. Astholz, K. Glänzer, and J. Troe

*Institut für Physikalische Chemie der Universität, Tammannstr. 6, D-3400 Göttingen, Germany*  
(Received 17 October 1978)

Rate constants for the spin-forbidden dissociation process  $\text{SO}_3 + \text{Ar} \rightarrow \text{SO}_2 + \text{O} + \text{Ar}$  have been measured in shock waves between 1700 and 2500 K. The results are compared with data on the low temperature (200–400 K) recombination reaction. The analysis in terms of unimolecular reaction rate theory allows for a determination of the threshold energy of the reaction.

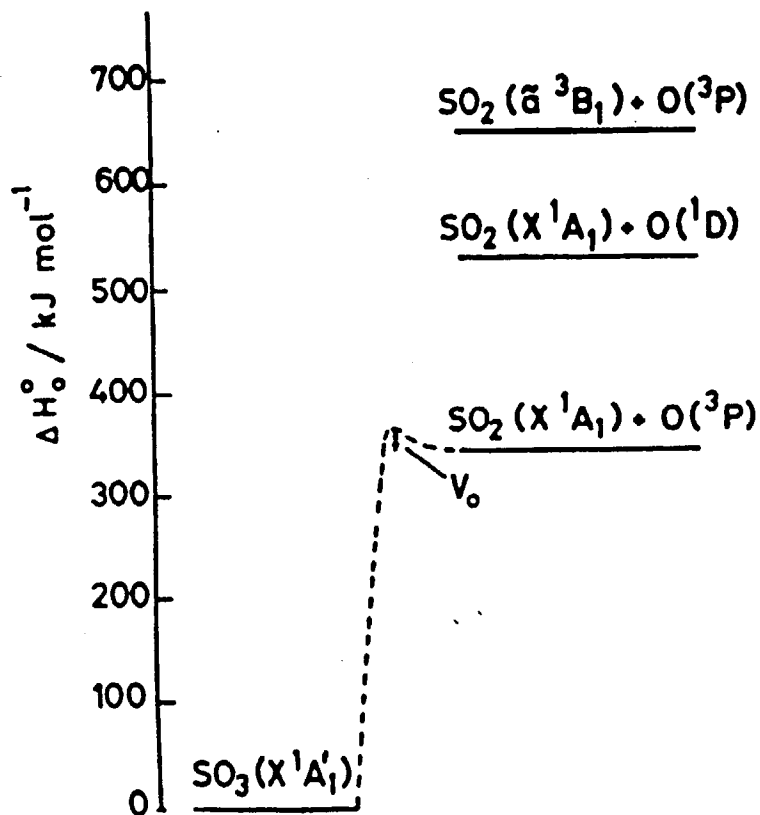
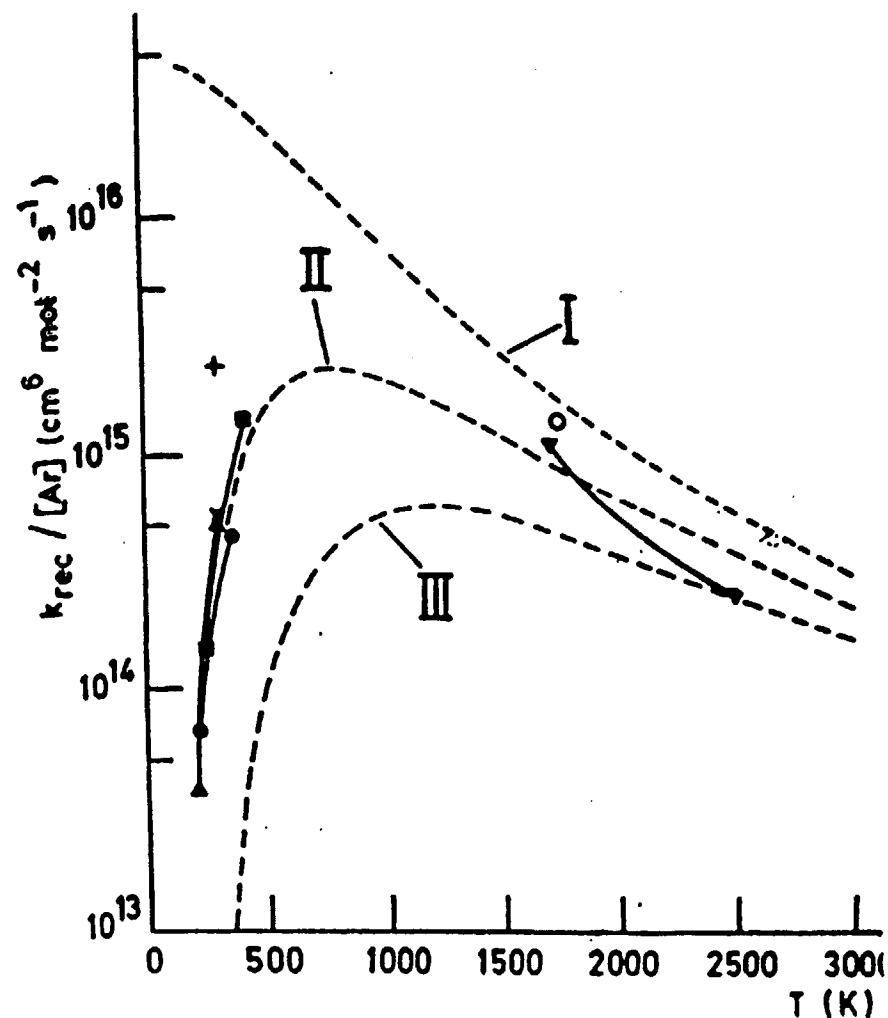

FIG. 1. Energy diagram for the  $\text{SO}_3 = \text{SO}_2 + \text{O}$  system.



# **TRACE CHEMISTRY**

*KRISHNAN RADHAKRISHNAN*

*PHILLIP WHITEFIELD*

# **INSTRUMENTATION**

*MICHELLE ZALLER*

*RICHARD MIAKE-LYE*

# **VENUES & PROCEDURES**

*PETER PACHLHOFER*

*ROBERT HOWARD*

***IMMEDIATE***

**Near Term**

**L O N G T E R M**

IS A JET ENGINE THE BEST

PLACE TO STUDY WHAT GOES ON

IN A JET ENGINE?

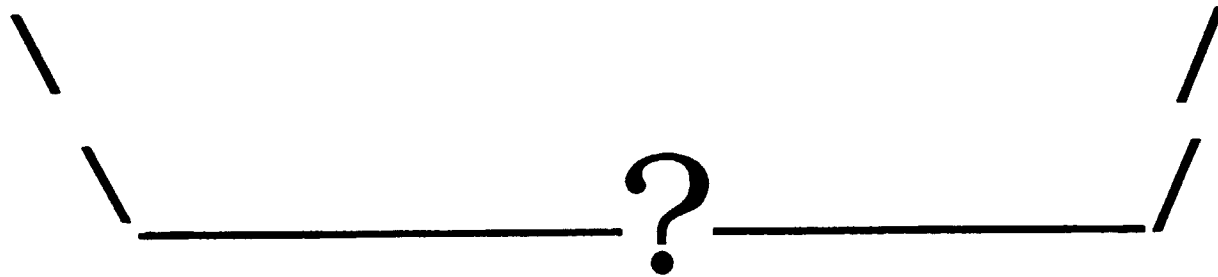
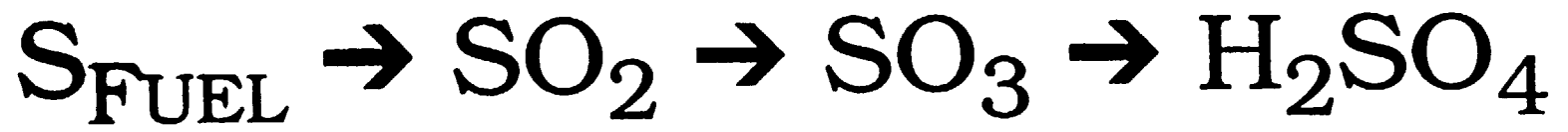

# AEROSOLS & PRECURSORS

SPECIES

REACTIONS AND RATES

THERMOCHEMISTRY

AND

TRANSPORT

## TRACE CHEMISTRY

Krishnan Radhakrishnan  
NASA Glenn Research Center  
Cleveland, Ohio

and

Philip Whitefield  
University of Missouri—Rolla  
Rolla, Missouri

The goals of the trace chemistry group were to identify the processes relevant to aerosol and aerosol precursor formation occurring within aircraft gas turbine engines; that is, within the combustor, turbine, and nozzle. The topics of discussion focused on whether the chemistry of aerosol formation is homogeneous or heterogeneous; what species are important for aerosol and aerosol precursor formation; what modeling/theoretical activities to pursue; what experiments to carry out that both support modeling activities and elucidate fundamental processes; and the role of particulates in aerosol and aerosol precursor formation.

The consensus of the group was that attention should be focused on  $\text{SO}_2$ ,  $\text{SO}_3$ , and aerosols. Of immediate concern is the measurement of the concentration of the species  $\text{SO}_3$ ,  $\text{SO}_2$ ,  $\text{H}_2\text{SO}_4$ ,  $\text{OH}$ ,  $\text{HO}_2$ ,  $\text{H}_2\text{O}_2$ ,  $\text{O}$ ,  $\text{NO}$ ,  $\text{NO}_2$ ,  $\text{HONO}$ ,  $\text{HNO}_3$ ,  $\text{CO}$ , and  $\text{CO}_2$  and particulates in various engines, both those currently in use and those in development. The recommendation was that concentration measurements should be made at both the combustor exit and the engine exit. At each location the above species were classified into one of four categories of decreasing importance, Priority I through IV, as follows:

### Combustor Exit:

- Priority I species -  $\text{SO}_3$ : $\text{SO}_2$  ratio,  $\text{SO}_3$ ,  $\text{SO}_2$ , and particulates;
- Priority II species -  $\text{OH}$  and  $\text{O}$ ;
- Priority III species -  $\text{NO}$  and  $\text{NO}_2$ ;
- Priority IV species -  $\text{CO}$  and  $\text{CO}_2$ .

### Engine Exit:

- Priority I species -  $\text{SO}_3$ : $\text{SO}_2$  ratio,  $\text{SO}_3$ ,  $\text{SO}_2$ ,  $\text{H}_2\text{SO}_4$ , and particulates;
- Priority II species -  $\text{OH}$ ,  $\text{HO}_2$ ,  $\text{H}_2\text{O}_2$ , and  $\text{O}$ ;
- Priority III species -  $\text{NO}$ ,  $\text{NO}_2$ ,  $\text{HONO}$ , and  $\text{HNO}_3$ ;
- Priority IV species -  $\text{CO}$  and  $\text{CO}_2$ .

Table I summarizes the anticipated concentration range of each of these species. For particulate matter, the quantities of interest are the number density, size distribution, and composition. In order to provide data for validating multidimensional reacting flow models, it would be desirable to make 2-D, time-resolved measurements of the concentrations of the above species and, in addition, of the pressure, temperature, and velocity. A near term goal of the experimental program should be to confirm the nonlinear effects of sulfur speciation, and if present, to provide an explanation for them. It is also desirable to examine if the particulate matter retains any sulfur. The recommendation is to examine the effects on  $\text{SO}_x$  production of variations in fuel-bound sulfur and aromatic content (which may affect the amount of particulates formed). These experiments should help us to understand if there is a coupling

between particulate formation and  $\text{SO}_x$  concentration. Similarly, any coupling with  $\text{NO}_x$  can be examined either by introducing  $\text{NO}_x$  into the combustion air or by using fuel-bound nitrogen.

Also of immediate urgency is the need to establish and validate a detailed mechanism for sulfur oxidation/aerosol formation, whose chemistry is concluded to be homogeneous, because there is not enough surface area for heterogeneous effects. It is envisaged that this work will involve both experimental and theoretical programs. The experimental work will require, in addition to the measurements described above, fundamental studies in devices such as flow reactors and shock tubes. Complementing this effort should be modeling and theoretical activities. One impediment to the successful modeling of sulfur oxidation is the lack of reliable data for thermodynamic and transport properties for several species, such as aqueous nitric acid, sulfur oxides, and sulfuric acid. Quantum mechanical calculations are recommended as a convenient means of deriving values for these properties. Such calculations would also help establish rate constants for several important reactions for which experimental measurements are inherently fraught with uncertainty. Efforts to implement sufficiently detailed chemistry into computational fluid dynamic codes should be continued. Zero- and one-dimensional flow models are also useful vehicles for elucidating the minimal set of species and reactions that must be included in two- and three-dimensional modeling studies.



## INSTRUMENTATION WORKING GROUP SUMMARY

Michelle Zaller  
NASA Glenn Research Center  
Cleveland, Ohio

and

Richard Miake-Lye  
Aerodyne Research, Inc.  
Billerica, Massachusetts

The Instrumentation Working Group compiled a summary of measurement techniques applicable to gas turbine engine aerosol precursors and particulates. An assessment was made of the limits, accuracy, applicability, and technology readiness of the various techniques. These are summarized in Table I. Despite advances made in emissions characterization of aircraft engines, uncertainties still exist in the mechanisms by which aerosols and particulates are produced in the near-field engine exhaust. To adequately assess current understanding of the formation of sulfuric acid aerosols in the exhaust plumes of gas turbine engines, measurements are required to determine the degree and importance of sulfur oxidation in the turbine and at the engine exit. Ideally, concentrations of all sulfur species would be acquired, with emphasis on  $\text{SO}_2$  and  $\text{SO}_3$ .

Numerous options exist for extractive and non-extractive measurement of  $\text{SO}_2$  at the engine exit, most of which are well developed (see Table I).  $\text{SO}_2$  measurements should be performed first to place an upper bound on the percentage of  $\text{SO}_2$  oxidation. If extractive and non-extractive techniques indicate that a large amount of the fuel sulfur is not detected as  $\text{SO}_2$ , then efforts are needed to improve techniques for  $\text{SO}_3$  measurements. Based on the preliminary results of recent F-100 engine tests conducted at NASA Lewis Research Center, for which about 75% of the fuel sulfur was measured as  $\text{SO}_2$ , additional work will be required to account for the fuel sulfur in the engine exhaust. CI-MS measurements need to be pursued, although a careful assessment needs to be made of the sampling line impact on the extracted sample composition. Efforts should also be placed on implementing non-intrusive techniques and extending their capabilities by maximizing exhaust coverage for line-of-sight measurements, as well as development of 2-D techniques, where feasible.

Recommendations were made to continue engine exit and combustor measurements of particulates. Particulate measurements should include particle size distribution, mass fraction, hydration properties, and volatile fraction. These measurements have already been made using extractive sampling from gas turbine combustor rigs and engine exhausts, so numerous refinements have been made to commercial instruments that measure particulate size distribution and number density. However, methods to ensure that unaltered samples are obtained need to be developed. Particulate speciation was also assigned a high priority for quantifying the fractions of carbon soot, PAH, refractory materials, metals, sulfates, and nitrates. Determination of carbon soot morphology was given a lower priority than the particulate speciation.

High priority was also placed on performing a comparison of particle sizing instruments. Concern was expressed by the workshop attendees who routinely make particulate measurements about the variation in number density measured during in-flight tests by different instruments. In some cases, measurements performed by different groups of researchers during the same flight tests showed an order of magnitude variation. The University of Minnesota offered to host a comparison test, but the logistics of getting several groups and sets of equipment together at the same place and time were agreed to be difficult. An alternative would be to send a particle generator to the various laboratories, if schedule conflicts prohibit a common test location and time.

Second priority was assigned to measuring concentrations of odd hydrogen and oxidizing species. Since OH,  $\text{HO}_2$ ,  $\text{H}_2\text{O}_2$ , and O are extremely reactive, non-extractive measurements are recommended. A combination of absorption and fluorescence is anticipated to be effective for OH measurements in the combustor and at the engine exit. Extractive measurements of  $\text{HO}_2$  have been made in the stratosphere, where the ambient level of OH is relatively low. Use of techniques that convert  $\text{HO}_2$  to OH for combustor and engine exit measurements needs to be evaluated, since the ratio of  $\text{HO}_2/\text{OH}$  may be 1% or less at both the combustor and engine exit. CI-MS might be a viable option for  $\text{H}_2\text{O}_2$ , subject to sampling line conversion issues. However,  $\text{H}_2\text{O}_2$  is a low priority oxidizing

species in the combustor and at the engine exit, since it is calculated to be present in concentrations of 0.1% or less of the OH mole fraction at the engine exit [Miake-Lye et al, 1992]. Atomic oxygen may be present at levels from 2-10% of OH in the combustor, but is expected to be negligible at the engine exit. The two candidates for atomic oxygen measurements are REMPI and LIF. Both of these have been performed in atmospheric pressure laboratory burners, but need to be proven under gas turbine combustor exit conditions.

Particulate measurement by simultaneous extractive and non-extractive techniques was given equal priority to the oxidizer measurements. Concern was expressed over the ability of typical ground test sampling lines to deliver an unaltered sample to a remotely located instrument, and it was suggested that the sampling probe and line losses be checked out by attempting measurements using an optical or non-extractive technique immediately upstream of the sampling probe. This is a possible application for LII as a check on the volume fraction of soot. Optical measurements of size distribution are not well developed for ultrafine particles less than about 20 nm in diameter, so a non-extractive technique for particulate size distribution cannot be recommended without further development.

Carbon dioxide measurements need to be made to complement other extractive measurement techniques. Although total engine CO<sub>2</sub> emissions can be calculated based on fuel consumption, carbon dioxide measurements enable conversion of other species concentrations to emission indices. Carbon monoxide, which acts as a sink for oxidizing species, should be measured using non-extractive techniques. CO can be rapidly converted to CO<sub>2</sub> in extractive probes, and a comparison between extractive and non-extractive measurements should be performed. Development of non-extractive techniques would help to assess the degree of CO conversion, and might be needed to improve the concentration measurement accuracy.

Measurements of NO<sub>x</sub> will continue to be critical due to the role of NO and NO<sub>2</sub> in atmospheric chemistry, and their influence on atmospheric ozone. In addition, NO<sub>x</sub> emissions must be characterized to ensure compliance with ICAO standards. Due to the importance of NO<sub>x</sub> emissions, a variety of extractive and non-extractive techniques have been demonstrated in gas turbine combustor and engine exit measurements. However, NO<sub>x</sub> measurements have been assigned a lower priority than the oxidizing species because it performs a minimal role in the formation of sulfuric acid aerosols. In addition, ground-based and in-flight measurements of NO<sub>x</sub> emission indices have previously been shown to be well correlated, indicating that the plume processes influencing NO<sub>x</sub> are well understood [Friedl, 1997].

Although NO<sub>x</sub> emissions are of general engine emission importance, the various (non-NO<sub>x</sub>) NO<sub>y</sub> species are not thought to have a major role in aerosol and particulate formation. Nitrous and nitric acid may form aerosols, possibly in combination with sulfuric acid; however, concentrations of nitric acid are expected to be several orders of magnitude less than sulfuric acid in the engine exhaust. Techniques were identified that could be applied to HNO<sub>2</sub> and HNO<sub>3</sub>. Further development is needed to optimize techniques for HNO<sub>2</sub> measurements. HNO<sub>3</sub> concentration measurements have already been demonstrated using CI-MS, with non-extractive techniques requiring additional work.

Time-resolved measurements of temperature, velocity, and species concentrations were included on the list of desired measurements. Thermocouples are typically adequate for engine exit measurements. Several non-intrusive techniques for temperature measurements have been used in combustor test facilities, but are generally difficult to apply. PIV and LDV are well-established for obtaining velocity profiles, but require seeding the flow with non-reactive particles. LIF and PLIF can measure species concentrations nearly instantaneously, but absolute species concentrations can be difficult to quantify. Combinations of absorption and fluorescence are the most likely to be successful at obtaining instantaneous concentration profiles of trace species, but not all species can be detected with fluorescence techniques.

Measurements of total hydrocarbons are routinely made to meet ICAO standards. However, hydrocarbon chemistry is not believed to be a major factor in aerosol formation. Speciation of organic compounds present in engine exhausts [Spicer et al, 1994] have shown that less than 0.2 ppm of PAH

were present at typical cruise conditions, so liquid or solid phase hydrocarbon aerosols are not expected to be a major contributor, compared with sulfuric acid aerosols.

Overall, there is good overlap between estimated species concentrations and instrumentation detection limits. Measurement techniques for very reactive species, such as SO<sub>3</sub>, O, HNO<sub>2</sub>, and H<sub>2</sub>O<sub>2</sub>, will require additional development. Chemical ionization mass spectrometry (CI-MS) is a promising technique for many of the trace species, but careful quenching and dilution of the extracted sample must be performed to ensure an unaltered measurement. Infrared absorption (IR-TDLAS) has sufficient sensitivity for measurements of most of the trace species at the engine exit, with the advantage of being non-extractive. For combustor exit measurements of OH, a combination of UV absorption and fluorescence is expected to be successful, since UV absorption measurements of OH have been made in elevated pressure flames, and PLIF measurements of OH have been demonstrated in optically-accessible subscale combustor test facilities.

The techniques listed in Table I are divided up into extractive and non-extractive techniques, with the assumption that extractive measurements can be made from the combustor and the engine exit. Efforts were made to include a measurement uncertainty for each technique. These uncertainties are for the detection limit as listed, and may be less for other measurement values. Order-of magnitude estimates of species concentrations at the combustor and engine exit are listed. These numbers are predominantly from equilibrium calculations (combustor exit) and Miake-Lye et al, 1992 (engine exit). An assessment of the technology readiness was included, with an "A" designating techniques that have been used in gas turbine engine tests. "B" status was assigned to techniques that have been demonstrated in the laboratory, typically in burners, shock tubes, or flow reactors. "C" technology readiness was given for techniques that should be applicable for the species listed, but have not yet been proven. Although efforts were made to be comprehensive, techniques may have been unintentionally omitted.

Many researchers contributed to the compilation of instrumentation techniques listed in Table I. The efforts of Bruce Anderson, Pratim Biswas, Mike Coggiola, Gus Fralick, Gary Hunter, David Liscinsky, Randy Locke, Quang-Viet Nguyen, Daniel Oh, Al Viggiano, and Joda Wormhoudt are especially appreciated. Thanks are also due to Mike Coggiola, Daniel Oh, David Pui, Terry Rawlins, Jerry Seitzman, Dick Strange, Al Viggiano, and Michael Winters for their contributions to the workshop instrumentation session.

**References:**

Friedl, R. R., ed., Atmospheric effects of subsonic aircraft: interim assessment report of the advanced subsonic technology program. NASA RP-1400, 1997.

Miake-Lye, R. C., Dodds, W. J., Fahey, D. W., Kolb, C. E., and Langhoff, S. R., Engine trace constituent measurements recommended for the assessment of the atmospheric effects of stratospheric aircraft. Aerodyne Research report ARI-RR-947, 1992.

Spicer, C. W., Holdren, M. W., Riggin, R. M., and Lyon, T. F., Chemical composition and photochemical reactivity of exhaust from aircraft turbine engines. Annales Geophysicae, 12, 944-955, 1994.

**Table I. Estimated Mole Fractions for Aerosol Precursors and Particulates**

Species	Combustor Exit	Engine Exit
SO <sub>2</sub>	1 E-5	1 E-6
SO <sub>3</sub>	1 E-7	1 E-6
H <sub>2</sub> SO <sub>4</sub>	1 E-11	1 E-9
NO	0.001	1 E-5
NO <sub>2</sub>	1 E-5	1 E-6

HNO2	1 E-7	1 E-9
HNO3	1 E-10	1 E-11
CO	1 E-6	1 E-7
CO2	0.05	0.05
HO	1 E-4	1 E-5
HO2	1 E-6	1 E-7
H2O2	1 E-7	1 E-8
O	1 E-6	1 E-12

**Table II. Measurement Techniques for Characterizing Aerosol Precursors and Particulates**

Species	Measurement technique	Detection limit or accuracy		Technology readiness	
		Extractive	Non-Extractive		
			Combustor exit	Engine exit	
SO <sub>2</sub>	IR-TDLAS			1 ppmv	A
	CI-MS	100 ppt (+/- 20%)			A
	Commercial fluorescence analyzer	10 ppb (+/- 0.5 ppb) <sup>b</sup>			B
	LIF		30 ppb	0.6 ppb	B
	Point Contact Microsensors			1 ppm	C
	UV-WMS		5 ppbv <sup>c</sup>	2 ppbv <sup>c</sup>	B
	Flame Photometric Detection	1 ppbv (+/- 1 ppbv)			A
	FTIR-ES			170 ppmv <sup>c</sup>	C
SO <sub>3</sub>	IR-TDLAS			5 ppmv	A
	CI-MS	100 ppt (+/- 30%) <sup>a</sup>			A
	Point Contact Microsensors			2 ppm	C <sup>1</sup>
H <sub>2</sub> SO <sub>4</sub>	CI-MS	100 ppt (+/-30%) <sup>a</sup>			A
SO <sub>4</sub> <sup>2-</sup>	Extractive Condensation, Ion Chromatography	1 ppbv (+/- 1 ppbv)			A
Particulates	Smoke number	1-100 SN			A
	Gravimetric sampling	Particulate accumulation (µg/cm <sup>2</sup> )			A
	CNC/EAC	3-200 nm			A
	CNC/EAC	10 <sup>6</sup> /cc			A
	LII		1 ppm	1 ppm	B
	Rayleigh		(size distribution)	(size distribution)	C
	Dynamic light scattering		>10 nm	>10 nm	B
	Mie scattering		40-2000 nm	40-2000 nm	B
	Electron Microscopy	Morphology			A
	Aerosol Mass Spectrometer	Bulk composition			B
	Single Particle Mass Spectrometer	Bulk composition			A
	Coated impactor	Surface composition			B
	Soluble mass fraction	Hydration properties			B
	Quartz Crystal Microbalance	Particulate accumulation (µg/cm <sup>2</sup> )			B

Species	Measurement technique	Detection limit or accuracy		Technology readiness1
		Extractive	Non-Extractive	
			Combustor exit    Engine exit	
NO	Chemiluminescence analyzer	10 ppm (+/- 4%)		A
	FTIR-ES		50 ppmv <sup>c</sup>	A
	IR-TDLAS		0.4 ppmv	A
	PLIF		5 ppm	A
	UV absorption		5 ppm	B, A
	Point contact microsensor		1 ppm	B
NO <sub>2</sub>	Chemiluminescence analyzer with catalytic conversion	2 ppm (+/- 4%)		A
	IR-TDLAS		1 ppmv	A
	FTIR-ES		30 ppmv <sup>c</sup>	B
	Point contact microsensor		0.5 ppm	B
	LIF		50 +/- 10 ppm	C
HNO <sub>2</sub>	CI-MS	100 ppt (+/- 30%) <sup>a</sup>		B
	IR-TDLAS		5 ppmv <sup>c</sup>	B
	UV Absorption		100 ppmv (+/- 2%) <sup>c</sup>	B
	PD-LIF		1 ppm    100 ppb (+/- 10 ppb)	C
HNO <sub>3</sub>	CI-MS	100 ppt (+/- 20%)		A
	IR-TDLAS		2 ppmv <sup>c</sup>	B
	FTIR-ES		20 ppm <sup>c</sup>	B
	PD-LIF		10 +/- 1 ppb	B
CO	Commercial analyzer	5 +/- 2 ppm		A
	FTIR-ES		10 ppmv <sup>c</sup>	A
	IR-TDLAS		0.2 ppmv	A
	Point contact microsensor		1 ppm	B
CO <sub>2</sub>	Commercial analyzer	120 +/- 50 ppm		A
	IR-TDLAS		300 ppmv	A
	FTIR-ES		30 ppmv <sup>c</sup>	A

Species	Measurement technique	Detection limit or accuracy		Technology readiness <sup>1</sup>	
		Extractive	Non-Extractive		
			Combustor exit	Engine exit	
HO	IR-TDLAS			1 ppmv	C
	PLIF		1 ppm	1 ppm	A
	LIF		25 ppbv	0.3 ppbv	B
	LIF	0.02 ppbv (+/- 40%) <sup>a</sup>			A
	UV-WMS		3 ppbv <sup>c</sup>	0.2 ppbv <sup>c</sup>	B
HO <sub>2</sub>	Conversion by NO to HO	0.05 ppbv (+/- 30%) <sup>a</sup>			A
	IR-TDLAS			5 ppmv	B
H <sub>2</sub> O <sub>2</sub>	CI-MS	0.1 ppbv (+/- 30%) <sup>a</sup>			C
	HPLC	0.01 ppbv <sup>a</sup>			B
	PD-LIF	5 ppbv (+/- 50%) <sup>a</sup>			C
	IR-TDLAS			2 ppmv	C
O	2-photon LIF		500 ppm +/- 15%		B
	LIF		10 +/- 5 ppm		B
	REMPI		500 ppm +/- 15%		B
Temperature	Thermocouple (Type R)		3200 °F +/- 5%; 2000 K +/- 5%	3200 °F +/- 5%; 2000 K +/- 5%	A
	Pyrometry		3700 +/- 100°F; 2300 +/- 60 K	3700 +/- 100°F; 2300 +/- 60 K	C
	Raman		+/- 10%	+/- 10%	B
	LIF		+/- 10%		B
	Rayleigh			+/- 5%	B
	Acoustic thermometry		4000 +/- 100°F; 2500 +/- 60 K		B
	Velocity	PIV		+/- 2%	+/- 2%
LDV			+/- 2%	+/- 2%	A
Filtered Rayleigh				+/- 5%	B
Species Concentration Profiles	UV absorption/LIF (line of sight)			+/- 1%	B
	TDLAS (line of sight)			+/- 1%	A
	PLIF (planar)		5 ppm +/- 10%	5 ppm +/- 10%	A
	Raman		.05 +/- 40%	.05 +/- 40%	B

<sup>a</sup> function of sample line conversion

<sup>b</sup> with HC removal

<sup>c</sup>for typical engine exit compositions, temperatures, and pathlengths

1A=Demonstrated in engine tests; B=Demonstrated in laboratory; C=Not yet demonstrated

Abbreviations:

CI-MS Chemical Ionization Mass Spectrometry

CNC/EAC Condensation Nuclei Counter/Electrostatic Aerosol Classifier

FTIR-ES	Fourier Transform Infrared Emission Spectroscopy
IR-TDLAS	Infrared Tunable Diode Laser Absorption Spectroscopy
LIF	Laser-Induced Fluorescence
LII	Laser-Induced Incandescence
PD-LIF	Photodissociative Laser Induced Fluorescence
UV-WMS	Ultraviolet Wavelength Modulation Spectroscopy



AEROSOLS AND PARTICULATES WORKSHOP SAMPLING PROCEDURES AND VENUES  
WORKING GROUP SUMMARY

Peter Pachlhofer  
NASA Glenn Research Center  
Cleveland, Ohio

and

Robert Howard  
Sverdrup Technology, Inc.  
Arnold AFB, Tennessee

The Sampling Procedures and Venues Workgroup discussed the potential venues available and issues associated with obtaining measurements. Some of the issues included Incoming Air Quality, Sampling Locations, Probes and Sample Systems. The following is a summary of the discussion of the issues and venues.

Incoming Air Quality

The influence of inlet air to the measurement of exhaust species, especially trace chemical species, must be considered. Analysis procedures for current engine exhaust emissions regulatory measurements require adjustments for air inlet humidity (SAE Procedures). As a matter of course in scientific investigations, it is recommended that "background" measurements for any species, particulate or chemical, be performed during inlet air flow before initiation of combustion, if possible, and during the engine test period as feasible and practical. For current regulatory measurements, this would be equivalent to setting the "zero" level for conventional gas analyzers.

As a minimum, it is recommended that measurements of the humidity and particulates in the incoming air be taken at the start and end of each test run. Additional measurement points taken during the run are desirable if they can be practically obtained. It was felt that the presence of trace gases in the incoming air is not a significant problem. However, investigators should consider the ambient levels and influences of local air pollution for species of interest.

Measurement Locations

Desired measurement locations depend upon the investigation requirements. A complete investigation of phenomenology of particulate formation and growth requires measurements at a number of locations both within the engine and in the exhaust field downstream of the nozzle exit plane. Desirable locations for both extractive and in situ measurements include:

- Combustion Zone (Multiple axial locations)

- Combustor Exit (Multiple radial locations for annular combustors)
- Turbine Stage (Inlet and exit of the stage)
- Exit Nozzle (Multiple axial locations downstream of the nozzle)

Actual locations with potential for extractive or non-intrusive measurements depend upon the test article and test configuration. Committee members expressed the importance of making investigators aware of various ports that could allow access to various stages of the existing engines. Port locations are engine specific and might allow extractive sampling or innovative hybrid optical-probe access. The turbine stage region was one the most desirable locations for obtaining samples and might be accessed through boroscope ports available in some engine designs.

### Probes and Sampling Systems

Discussions of probes and sampling systems quickly identified issues dependent on particular measurement quantities. With general consensus, the group recommends SAE procedures for measurements and data analyses of currently regulated exhaust species (CO<sub>2</sub>, CO, THC, NO<sub>x</sub>) using conventional gas sampling techniques. Special procedures following sound scientific practices must be developed as required for species and/or measurement conditions not covered by SAE standards. Several issues arose concerning short lived radicals and highly reactive species. For conventional sampling, there are concerns of perturbing the sample during extraction, line losses, line-wall reactions, and chemical reactions during the sample transport to the analyzers. Sample lines coated with quartz or other materials should be investigated for minimization of such effects.

The group advocates the development of innovative probe techniques and non-intrusive optical techniques for measurement of short lived radicals and highly reactive species that cannot be sampled accurately otherwise. Two innovative probe concepts were discussed. One concept uses specially designed probes to transfer optical beams to and from a region of flow inaccessible by traditional ports or windows. The probe can perturb the flow field but must have a negligible impact on the region to be optically sampled. Such probes are referred to as hybrid probes and are under development at AEDC for measurement in the high pressure, high temperature of a combustor under development for power generation.

The other concept consists of coupling an instrument directly to the probe. The probe would isolate a representative sample stream, freeze chemical reactions and direct the sample into the analyzer portion of the probe. Thus, the measurement would be performed in situ without sample line losses due either to reactions or binding at the wall surfaces. This concept was used to develop a fast, in situ, time-of-flight mass spectrometer measurement system for temporal quantification of NO in the IMPULSE facility at AEDC.

Additional work is required in this area to determine the best probe and sampling technique for each species measurement requirement identified by the Trace Chemistry Working Group.

### Venues

A partial list of Venues was used as a baseline for discussion. Additional venues were added to the list and the list was broken out into the following categories:

- Engines
  - Sea Level Test Stands
  - Altitude Chambers
- Annular Combustor Test Stands
- Sector/Flametube Test Stands
- Fundamentals Rigs/Experiments

A list of the information desired for each venue was created along with the a list of contact persons for each venue. The original partial list of venues has been updated with the new information and is attached to this summary.

**ATTACHMENT I**

**COMBUSTOR FACILITIES AND CAPABILITIES FOR PARTICULATES  
AND AEROSOLS MEASUREMENTS**

**Jean Bianco  
NASA Glenn Research Center  
Cleveland, Ohio**

**ENGINE TEST FACILITIES AND CAPABILITIES  
SEA LEVEL**

## VENUES FOR PARTICULATES/AEROSOLS MEASUREMENTS

ORGANIZATION: NASA LcRC  
FACILITY: PSL  
TEST HARDWARE: Full Engines

CONDITIONS: PRESSURE 140 psia  
TEMP -50-900°F non-vitiated, 3000°F vitiated  
FLOW 480 pps  
VITIATED OR NON-VITIATED both  
EXIT TEMP 3500°F  
ATM OR ALT EXHAUST atm and alt to 70,000 ft.  
OTHER:  
NITROGEN 131,500 SCF storage at 2400 psig  
NATURAL GAS 10" header supply at 45 psia  
OXYGEN 210,000 SCF at 2400 psig, flows to 11.5 pps  
HYDROGEN 560,000 SCF at 2400 psi, (1 pps at 350 psig,  
2.75 pps at 1000 psig)

*HEATER TYPE Non-vitiated: (2) J57 engines & afterburners  
via shell and tube;  
Vitiated: (3) GH2 heaters.*

*HEATER PRESSURE/TEMP 60 pps, 450 psia, 500°F(1999 goal)*

*FUEL STORAGE (2) 25,000 gal tanks; Jet A and any other jet  
fuel*

*FUEL FLOW pump 1: 200 gpm; pump 2: 10 gpm*

*FUEL PRESSURE pump 1: 60 psig; pump 2: 720 psig*

*H2O COOLING PRESSURE/FLOW 500 gpm/40 psig*

AVAILABILITY: Variable

TEST FREQUENCY: Daily, 3-5 days per week

COST(\$/DAY): ~\$5,000 per run hour, ~\$1,000 per day per non-run day

SETUP/COORDINATION COST: Preparation and installation costs for engineering and technicians is about \$15K per week, excluding design and fabrication costs.

INSTRUMENTATION

Standard gas analyzers - Rosemount; CO, CO<sub>2</sub>, NO, NO<sub>x</sub>, O<sub>2</sub>, UHC;

Smoke meter; particle measurement system

SAMPLING

PROBES: X-Y traverse mechanism available, no facility probes.

LINES: Smooth-bore stainless steel, approx. 50 feet long, electrically heated.

OTHER REMARKS:

CONTACT: Technical - Rick Sorge (216) 433-8304  
(Acting) Facility Manager - Mahmood Abdelwahab (216) 433-5701

## VENUES FOR PARTICULATES/AEROSOLS MEASUREMENTS

ORGANIZATION: Pratt & Whitney Middletown Facility

FACILITY: X960 High Pressure Combustion Laboratory Test Facility

TEST HARDWARE: Moderate pressure testing at representative inlet temperatures

CONDITIONS:       PRESSURE 650 psia  
                      TEMP       1200°F  
                      FLOW       100 pps  
                      VITIATED OR NON-VITIATED non-vitiated  
                      EXIT TEMP  
                      ATM OR ALT EXHAUST  
                      OTHER  
                              HYDROGEN 2400 psi  
                              OXYGEN 2400 psi  
                              NITROGEN 2400 psi

*HEATER TYPE*

*HEATER PRESSURE/TEMP*

*FUEL STORAGE (3) 1000 gal, (3) 4000 gal; (1) 10,000 gal tank*

*FUEL FLOW 44 GPM*

*FUEL PRESSURE 1500 psig*

*H2O COOLING PRESSURE/FLOW 700 psi*

AVAILABILITY:

TEST FREQUENCY:

COST(\$/DAY):

SETUP/COORDINATION COST:

INSTRUMENTATION

Standard gas analyzers: CO, CO<sub>2</sub>, NO, NO<sub>x</sub>, O<sub>2</sub>, UHC; Smoke meter

SAMPLING

PROBES: Capable of sampling at 30 locations.

LINES: Heated transfer lines

OTHER REMARKS:

CONTACT: Charlie Graves (407) 796-5289

## VENUES FOR PARTICULATES/AEROSOLS MEASUREMENTS

ORGANIZATION: AEDC

FACILITY: SL1, SL2, SL3

TEST HARDWARE:

CONDITIONS:       PRESSURE  
                      TEMP  
                      FLOW  
                      VITIATED OR NON-VITIATED non-vitiated  
                      EXIT TEMP  
                      ATM OR ALT EXHAUST atm  
                      OTHER  
                          HYDROGEN  
                          OXYGEN  
                          NITROGEN

*HEATER TYPE*  
*HEATER PRESSURE/TEMP*  
*FUEL STORAGE*  
*FUEL FLOW*  
*FUEL PRESSURE*  
*H2O COOLING PRESSURE/FLOW*

AVAILABILITY:

TEST FREQUENCY:

COST(\$/DAY):

SETUP/COORDINATION COST:

INSTRUMENTATION

Standard gas analyzers: CO, CO<sub>2</sub>, NO, NO<sub>x</sub>, O<sub>2</sub>, UHC; Smoke meter

SAMPLING

PROBES: gas sampling, temperature, pressure, Mach/flow angularity

LINES: steam or electrical heated stainless steel

OTHER REMARKS:

CONTACT: Robert Howard (931) 454-4783

## VENUES FOR PARTICULATES/AEROSOLS MEASUREMENTS

ORGANIZATION: Pratt & Whitney

FACILITY: West Palm Beach

TEST HARDWARE:

CONDITIONS:      PRESSURE  
                      TEMP  
                      FLOW  
                      VITIATED OR NON-VITIATED  
                      EXIT TEMP  
                      ATM OR ALT EXHAUST  
                      OTHER  
                          HYDROGEN  
                          OXYGEN  
                          NITROGEN

*HEATER TYPE*  
*HEATER PRESSURE/TEMP*  
*FUEL STORAGE*  
*FUEL FLOW*  
*FUEL PRESSURE*  
*H2O COOLING PRESSURE/FLOW*

AVAILABILITY:

TEST FREQUENCY:

COST(\$/DAY):

SETUP/COORDINATION COST:

INSTRUMENTATION

SAMPLING

    PROBES:

    LINES:

OTHER REMARKS:

CONTACT: Robert Lohmann (516) 796-4964



VENUES FOR PARTICULATES/AEROSOLS MEASUREMENTS

ORGANIZATION: Missouri Air National Guard

FACILITY:

TEST HARDWARE:

CONDITIONS:      PRESSURE  
                     TEMP  
                     FLOW  
                     VITIATED OR NON-VITIATED  
                     EXIT TEMP  
                     ATM OR ALT EXHAUST  
                     OTHER  
                              HYDROGEN  
                              OXYGEN  
                              NITROGEN

*HEATER TYPE*  
*HEATER PRESSURE/TEMP*  
*FUEL STORAGE*  
*FUEL FLOW*  
*FUEL PRESSURE*  
*H2O COOLING PRESSURE/FLOW*

AVAILABILITY:

TEST FREQUENCY:

COST(\$/DAY):

SETUP/COORDINATION COST:

INSTRUMENTATION

SAMPLING

    PROBES:

    LINES:

OTHER REMARKS:

CONTACT:

## VENUES FOR PARTICULATES/AEROSOLS MEASUREMENTS

ORGANIZATION: General Electric

FACILITY: Peebles

TEST HARDWARE:

CONDITIONS:      PRESSURE  
                      TEMP  
                      FLOW  
                      VITIATED OR NON-VITIATED  
                      EXIT TEMP  
                      ATM OR ALT EXHAUST  
                      OTHER  
                          HYDROGEN  
                          OXYGEN  
                          NITROGEN

*HEATER TYPE*  
*HEATER PRESSURE/TEMP*  
*FUEL STORAGE*  
*FUEL FLOW*  
*FUEL PRESSURE*  
*H2O COOLING PRESSURE/FLOW*

AVAILABILITY:

TEST FREQUENCY:

COST(\$/DAY):

SETUP/COORDINATION COST:

INSTRUMENTATION

SAMPLING

    PROBES:

    LINES:

OTHER REMARKS:

CONTACT: Paul Sabla (513) 552-2024

ENGINE TEST FACILITIES AND CAPABILITIES  
ALTITUDE

## VENUES FOR PARTICULATES/AEROSOLS MEASUREMENTS

ORGANIZATION: NASA LeRC

FACILITY: PSL

TEST HARDWARE: Full Engines

CONDITIONS:      PRESSURE 140 psia  
                    TEMP      -50-900°F non-vitiated, 3000°F vitiated  
                    FLOW      480 pps  
                    VITIATED OR NON-VITIATED both  
                    EXIT TEMP 3500°F  
                    ATM OR ALT EXHAUST atm and alt to 70,000 ft.

### OTHER:

NITROGEN 131,500 SCF storage at 2400 psig  
NATURAL GAS 10" header supply at 45 psia  
OXYGEN 210,000 SCF at 2400 psig, flows to 11.5 pps  
HYDROGEN 560,000 SCF at 2400 psi, (1 pps at 350 psig,  
2.75 pps at 1000 psig)

*HEATER TYPE Non-vitiated: (2) J57 engines & afterburners  
via shell and tube;*

*Vitiated: (3) GH2 heaters.*

*HEATER PRESSURE/TEMP 60 pps, 450 psia, 500°F(1999 goal)*

*FUEL STORAGE (2) 25,000 gal tanks; Jet A and any other jet  
fuel*

*FUEL FLOW pump 1: 200 gpm; pump 2: 10 gpm*

*FUEL PRESSURE pump 1: 60 psig; pump 2: 720 psig*

*H2O COOLING PRESSURE/FLOW 500 gpm/40 psig*

AVAILABILITY: Variable

TEST FREQUENCY: Daily, 3-5 days per week

COST(\$/DAY): ~\$5,000 per run hour, ~\$1,000 per day per non-run day

SETUP/COORDINATION COST: Preparation and installation costs for engineering and technicians is about \$15K per week, excluding design and fabrication costs.

### INSTRUMENTATION

Standard gas analyzers - Rosemount; CO, CO<sub>2</sub>, NO, NO<sub>x</sub>, O<sub>2</sub>, UHC;

Smoke meter; particle measurement system

### SAMPLING

PROBES: X-Y traverse mechanism available, no facility probes.

LINES: Smooth-bore stainless steel, approx. 50 feet long, electrically heated.

### OTHER REMARKS:

CONTACT: Technical - Rick Sorge (216) 433-8304

(Acting) Facility Manager - Mahmood Abdelwahab (216) 433-5701

## VENUES FOR PARTICULATES/AEROSOLS MEASUREMENTS

ORGANIZATION: AEDC

FACILITY: Cell T-1 thru T-7

TEST HARDWARE: Full Engines

CONDITIONS:      PRESSURE 40 -260 psia  
                    TEMP - 80 - 1200 °F  
                    FLOW 20 - 800 pps  
                    VITIATED OR NON-VITIATED non-vitiated  
                    EXIT TEMP  
                    ATM OR ALT EXHAUST: Atm and Altitude to 100,000 ft  
                    OTHER  
                            HYDROGEN  
                            OXYGEN  
                            NITROGEN

*HEATER TYPE*  
*HEATER PRESSURE/TEMP*  
*FUEL STORAGE*  
*FUEL FLOW*  
*FUEL PRESSURE*  
*H2O COOLING PRESSURE/FLOW*

AVAILABILITY:

TEST FREQUENCY:

COST(\$/DAY):

SETUP/COORDINATION COST:

INSTRUMENTATION

Standard gas analyzers: CO, CO<sub>2</sub>, NO, NO<sub>x</sub>, O<sub>2</sub>, UHC; Smoke meter

SAMPLING

PROBES: gas sampling, temperature, pressure, Mach/flow angularity

LINES: steam or electrical heated stainless steel

OTHER REMARKS: Test Section Size 3 - 28 ft diameter, 9-85 ft length

Speed Range 0-Mach 4.0

CONTACT: Robert Howard (931) 454-4783

## VENUES FOR PARTICULATES/AEROSOLS MEASUREMENTS

ORGANIZATION: AEDC  
FACILITY: Cell J-1 and J-2  
TEST HARDWARE: Full Engines

CONDITIONS: PRESSURE  
TEMP 1480 °R  
FLOW  
VITIATED OR NON-VITIATED  
EXIT TEMP  
ATM OR ALT EXHAUST: Atm and Altitude to 80,000 ft  
OTHER  
HYDROGEN  
OXYGEN  
NITROGEN

*HEATER TYPE*  
*HEATER PRESSURE/TEMP*  
*FUEL STORAGE*  
*FUEL FLOW*  
*FUEL PRESSURE*  
*H2O COOLING PRESSURE/FLOW*

AVAILABILITY:  
TEST FREQUENCY:  
COST(\$/DAY):  
SETUP/COORDINATION COST:  
INSTRUMENTATION  
Standard gas analyzers: CO, CO<sub>2</sub>, NO, NO<sub>x</sub>, O<sub>2</sub>, UHC; Smoke meter  
SAMPLING

PROBES: gas sampling, temperature, pressure, Mach/flow angularity

LINES: steam or electrical heated stainless steel

OTHER REMARKS: Test Section Size: J-1 20 ft diameter x 67.3 ft length  
J-2 28 ft diameter x 50-85 ft length  
Speed Range 0-Mach 3.0

CONTACT: Robert Howard (931) 454-4783

## VENUES FOR PARTICULATES/AEROSOLS MEASUREMENTS

ORGANIZATION: AEDC  
FACILITY: Cell C-1 and C-2

TEST HARDWARE: Full Engines

CONDITIONS: PRESSURE 130 psia  
TEMP -110 - 1020 °F  
FLOW 1500 pps  
VITIATED OR NON-VITIATED non-vitiated  
EXIT TEMP  
ATM OR ALT EXHAUST: Atm and Altitude to 100,000 ft  
OTHER  
HYDROGEN  
OXYGEN  
NITROGEN

*HEATER TYPE*  
*HEATER PRESSURE/TEMP*  
*FUEL STORAGE*  
*FUEL FLOW*  
*FUEL PRESSURE*  
*H2O COOLING PRESSURE/FLOW*

AVAILABILITY:

TEST FREQUENCY:

COST(\$/DAY):

SETUP/COORDINATION COST:

INSTRUMENTATION

Standard gas analyzers: CO, CO<sub>2</sub>, NO, NO<sub>x</sub>, O<sub>2</sub>, UHC; Smoke meter

SAMPLING

PROBES: gas sampling, temperature, pressure, Mach/flow angularity

LINES: steam or electrical heated stainless steel

OTHER REMARKS: Test Section Size: C-2 28 ft diameter x 50-85 ft length

Speed Range 0-Mach 3.8

CONTACT: Robert Howard (931) 454-4783

## ANNULAR TEST FACILITIES AND CAPABILITIES

## VENUES FOR PARTICULATES/AEROSOLS MEASUREMENTS

ORGANIZATION: NASA LeRC

FACILITY: ECRL 1B

TEST HARDWARE: Sector and Full Annular

CONDITIONS:        PRESSURE 165 psia  
                      TEMP ambient-620°F non-vitiated; 2000°F vitiated  
                      FLOW        250 pps  
                      VITIATED OR NON-VITIATED    both  
                      EXIT TEMP 4000°F  
                      ATM OR ALT EXHAUST    both  
                      OTHER

*HEATER TYPE Non-vitiated: natural gas; Vitiated: J-58*

*OTHER HEATER PRESSURE/TEMP*

*FUEL STORAGE (2) 20,000 gal tanks, (2) 10,000 gal tanks*

*FUEL TYPE*

*FUEL FLOW        70 gpm*

*FUEL PRESSURE                75 psig*

*FUEL DISTRIBUTION*

*H2O COOLING PRESSURE/FLOW                1200 gpm/160 psig*

AVAILABILITY: Ready for occupancy in June 1998

TEST FREQUENCY: daily

COST(\$/DAY): \$1000/day + \$55/Megawatt Hr

SETUP/COORDINATION COST:

INSTRUMENTATION

Standard Gas Analyzers: CO, CO<sub>2</sub>, NO, NO<sub>x</sub>, O<sub>2</sub>, UHC;

Smoke meter, particle measurement system

SAMPLING

PROBES: 8 pitots, gas sampling on one probe; Probe actuated +/- 30° from vertical can give exhaust gas profile

LINES: Heated

OTHER REMARKS:

CONTACT: Technical - Gary Huber (216) 433-5688

(Acting) Facility Manager - Bob Freedman (216) 433-2038



## VENUES FOR PARTICULATES/AEROSOLS MEASUREMENTS

ORGANIZATION: NASA LeRC

FACILITY: ECRL 2A

TEST HARDWARE: Sector and Full Annular

CONDITIONS:      PRESSURE 150 psia  
                      TEMP 600°F or 700-2500°F  
                      FLOW        31.0 pps  
                      VITIATED OR NON-VITIATED    vitiated  
                      EXIT TEMP  
                      ATM OR ALT EXHAUST  
                      OTHER

*HEATER TYPE J-47 vitiated*  
*OTHER HEATER PRESSURE/TEMP*  
*FUEL STORAGE (2) 20,000 gal tanks and (2) 10,000 gal tanks*  
*FUEL TYPE     Jet A or JP-5 for J-47 and J-58 or natural gas for J-47*  
*FUEL FLOW     10 GPM*  
*FUEL PRESSURE        500-600 psig*  
*FUEL DISTRIBUTION*  
*H2O COOLING PRESSURE/FLOW        600 GPM/150 psig*

AVAILABILITY:

TEST FREQUENCY:

COST(\$/DAY):

SETUP/COORDINATION COST:

INSTRUMENTATION

SAMPLING

PROBES:

LINES:

OTHER REMARKS:

CONTACT: Technical - Queito Thomas (216) 433-3700  
(Acting) Facility Manager - Bob Freedman (216) 433-2038

## VENUES FOR PARTICULATES/AEROSOLS MEASUREMENTS

ORGANIZATION: NASA LeRC

FACILITY: ASCR

TEST HARDWARE: Flametube, Sector, and Regional Engine Full Annular

CONDITIONS:       PRESSURE 900 psia  
                  TEMP       1300°F  
                  FLOW 3-12 pps Flametube; 3-38 pps Sector/Full Annular  
                  VITIATED OR NON-VITIATED non-vitiated  
                  EXIT TEMP 3200°F  
                  ATM OR ALT EXHAUST atm  
                  OTHER  
                          NITROGEN: 2000 psig

*HEATER TYPE shell and tube*  
*OTHER HEATER PRESSURE/TEMP 50 pps, 150 psig,*  
*1700°F*

*FUEL STORAGE (1) 20,000 gal tank*  
*FUEL TYPE Jet A*  
*FUEL FLOW 20 gpm*  
*FUEL PRESSURE 2000 psig*  
*H2O COOLING PRESSURE/FLOW 3000 gpm/60 psig;*  
*670 gpm/250 psig;*  
*300 gpm/1500 psig*

### AVAILABILITY:

TEST FREQUENCY: 2 days/week

COST(\$/DAY): 450 psia air only - \$2K; 1250 psia air, flow less than 25 pps - \$6-10K;  
1250 psia air, flow more than 25 pps - \$10-16K; cost/occupancy hour: \$2,092

SETUP/COORDINATION COST: Flametube - assy \$600, installation \$240, +  
instrumentation; Sector - unknown at this time

### INSTRUMENTATION

Standard Gas Analyzers: CO, CO<sub>2</sub>, NO, NO<sub>x</sub>, O<sub>2</sub>, UHC; (2) Smokemeters - 1  
filter type and 1 optical; particle measurement system

Non-intrusive laser diagnostics: YAG pumped dye laser systems with wave  
length extension systems for obtaining UV light, Measurements include: planar mi  
scattering, phase doppler particle analysis(PDPA), LDV/PDPA, laser induced  
flourescence(LIF), planar laser induced flourescence(PLIF), RAMAN,  
SCHLIEREN, C2 FLUORESCENCE; Acoustics

## VENUES FOR PARTICULATES/AEROSOLS MEASUREMENTS

### OTHER REMARKS:

ORGANIZATION: NASA LeRC

FACILITY: ASCR(CONTINUED)

### SAMPLING

PROBES: SS, Water cooled, multi port; 2 probes can be used simultaneously in Flametube at axial locations 2.4", 4.5", 6.0", 7.5", 9.0", 11.0", 16", and 22" downstream of the combustion section inlet flange; 21 sampling lines are available for the Sector rig

LINES: Steam traced and Electrically heated; Inner Liner Material: First 12 ft are carbon black teflon, remainder is SS; Line Length: 100-120 ft

CONTACT: Technical - Pete Pachlhofer (216) 433-5705  
Facility Manager - Jeff Swan (216) 433-5434

**VENUES FOR PARTICULATES/AEROSOLS MEASUREMENTS**

**ORGANIZATION:** Allison Engine Company  
**FACILITY:** Test Department Combustor Facility  
**TEST HARDWARE:** Flametube, Sector and Full Annular

**CONDITIONS:**  
**PRESSURE**  
**TEMP**  
**FLOW**  
**VITIATED OR NON-VITIATED**  
**EXIT TEMP**  
**ATM OR ALT EXHAUST**  
**OTHER:**

*HEATER TYPE*  
*HEATER PRESSURE/TEMP*  
*FUEL STORAGE*  
*FUEL FLOW*  
*FUEL PRESSURE*  
*H2O COOLING PRESSURE/FLOW*

**AVAILABILITY:**  
**TEST FREQUENCY:**  
**COST(\$/DAY):**  
**SETUP/COORDINATION COST:**  
**INSTRUMENTATION**  
**SAMPLING**  
**PROBES:**  
**LINES:**  
**OTHER REMARKS:**

**CONTACT:** Ron Mutzl (317) 230-4702  
John Spratt (317) 230-2106

## VENUES FOR PARTICULATES/AEROSOLS MEASUREMENTS

ORGANIZATION: AlliedSignal  
FACILITY: C100 Combustor Facility  
TEST HARDWARE: Full Annular

CONDITIONS: PRESSURE 120 psia  
TEMP -72 - 800°F  
FLOW 20 pps  
VITIATED OR NON-VITIATED non-vitiated  
EXIT TEMP  
ATM OR ALT EXHAUST  
OTHER

*HEATER TYPE*  
*OTHER HEATER PRESSURE/TEMP*  
*FUEL STORAGE*  
*FUEL TYPE*  
*FUEL FLOW*  
*FUEL PRESSURE*  
*FUEL DISTRIBUTION*  
*H2O COOLING PRESSURE/FLOW*

AVAILABILITY:  
TEST FREQUENCY:  
COST(\$/DAY):  
SETUP/COORDINATION COST:  
INSTRUMENTATION

RR Optical Smokemeter

### SAMPLING

PROBES: Traversing, rotating rake at the back end of the rig, donut shaped, 5-6 ports, 8-10" downstream of injector, H2O cooled

LINES: Electrically heated

OTHER REMARKS:

CONTACT: Joe Zelina (602) 231-4576

ORGANIZATION: AlliedSignal  
FACILITY: SanTan Facility  
TEST HARDWARE: Full Annular

CONDITIONS:       PRESSURE 80 psia  
                    TEMP  
                    FLOW 2pps  
                    VITIATED OR NON-VITIATED   vitiated  
                    EXIT TEMP  
                    ATM OR ALT EXHAUST  
                    OTHER

*HEATER TYPE  
OTHER HEATER PRESSURE/TEMP  
FUEL STORAGE  
FUEL TYPE  
FUEL FLOW  
FUEL PRESSURE  
FUEL DISTRIBUTION  
H2O COOLING PRESSURE/FLOW*

AVAILABILITY:  
TEST FREQUENCY:  
COST(\$/DAY):  
SETUP/COORDINATION COST:  
INSTRUMENTATION  
SAMPLING  
    PROBES:  
    LINES:  
OTHER REMARKS:

CONTACT: Joe Zelina (602) 231-4576

## VENUES FOR PARTICULATES/AEROSOLS MEASUREMENTS

ORGANIZATION: General Electric - Evandale

FACILITY: Cell A18

TEST HARDWARE: HP Sector, HP Annular Combustors  
Emissions and Altitude Relight Testing

CONDITIONS:      PRESSURE 440 psia(30 ATM)  
                      TEMP      1140°F(1600°R)  
                      FLOW      200 pps  
                      VITIATED OR NON-VITIATED  
                      EXIT TEMP  
                      ATM OR ALT EXHAUST  
                      OTHER

*HEATER TYPE*  
*HEATER PRESSURE/TEMP*  
*FUEL STORAGE*  
*FUEL FLOW*  
*FUEL PRESSURE*  
*H2O COOLING PRESSURE/FLOW*

AVAILABILITY:

TEST FREQUENCY:

COST(\$/DAY):

SETUP/COORDINATION COST:

INSTRUMENTATION

SAMPLING

PROBES:

LINES:

OTHER REMARKS:

CONTACT: Claude Chauvette (513) 243-2626

## VENUES FOR PARTICULATES/AEROSOLS MEASUREMENTS

ORGANIZATION: General Electric - Evandale

FACILITY: Cell A19

TEST HARDWARE: HP Flametube, HP Single Module, LP Sector, LP Annular  
Combustors  
Emissions and Altitude Relight and Exit Temperature Profile  
Testing

CONDITIONS: PRESSURE 440 psia(30 ATM)  
TEMP 1040°F(1500°R)  
FLOW 45 pps  
VITIATED OR NON-VITIATED  
EXIT TEMP  
ATM OR ALT EXHAUST  
OTHER

*HEATER TYPE*  
*HEATER PRESSURE/TEMP*  
*FUEL STORAGE*  
*FUEL FLOW*  
*FUEL PRESSURE*  
*H2O COOLING PRESSURE/FLOW*

AVAILABILITY:

TEST FREQUENCY:

COST(\$/DAY):

SETUP/COORDINATION COST:

INSTRUMENTATION

SAMPLING

PROBES:

LINES:

OTHER REMARKS:

CONTACT: Claude Chauvette (513) 243-2626



VENUES FOR PARTICULATES/AEROSOLS MEASUREMENTS

ORGANIZATION: General Electric - Evandale

FACILITY: Cell A5

TEST HARDWARE: MP Flametube, LP Single Module, LP Sector, LP Annular  
Combustors  
Emissions, Exit Temperature Profile, LBO Testing

CONDITIONS: PRESSURE 220 psia(15 ATM)  
TEMP 1140°F(1600°R)  
FLOW 10 pps  
VITIATED OR NON-VITIATED  
EXIT TEMP  
ATM OR ALT EXHAUST  
OTHER

*HEATER TYPE*  
*HEATER PRESSURE/TEMP*  
*FUEL STORAGE*  
*FUEL FLOW*  
*FUEL PRESSURE*  
*H2O COOLING PRESSURE/FLOW*

AVAILABILITY:

TEST FREQUENCY:

COST(\$/DAY):

SETUP/COORDINATION COST:

INSTRUMENTATION

SAMPLING

PROBES:

LINES:

OTHER REMARKS:

CONTACT: Claude Chauvette (513) 243-2626

## VENUES FOR PARTICULATES/AEROSOLS MEASUREMENTS

ORGANIZATION: General Electric - Evandale

FACILITY: Cell 306

TEST HARDWARE: LP Flametube, LP Single Module, LP Sector  
Emissions, Altitude Relight, Exit Temperature Profile and LBO  
Testing

CONDITIONS: PRESSURE 118 psia(8 ATM)  
TEMP 740°F(1200°R)  
FLOW 10 pps  
VITIATED OR NON-VITIATED  
EXIT TEMP  
ATM OR ALT EXHAUST  
OTHER

*HEATER TYPE*  
*HEATER PRESSURE/TEMP*  
*FUEL STORAGE*  
*FUEL FLOW*  
*FUEL PRESSURE*  
*H2O COOLING PRESSURE/FLOW*

AVAILABILITY:

TEST FREQUENCY:

COST(\$/DAY):

SETUP/COORDINATION COST:

INSTRUMENTATION

SAMPLING

PROBES:

LINES:

OTHER REMARKS:

CONTACT: Claude Chauvette (513) 243-2626

## VENUES FOR PARTICULATES/AEROSOLS MEASUREMENTS

ORGANIZATION: Wright Patterson Air Force Base

FACILITY:

TEST HARDWARE:

CONDITIONS:      PRESSURE  
                    TEMP  
                    FLOW  
                    VITIATED OR NON-VITIATED  
                    EXIT TEMP  
                    ATM OR ALT EXHAUST  
                    OTHER  
                            HYDROGEN  
                            OXYGEN  
                            NITROGEN

*HEATER TYPE*  
*HEATER PRESSURE/TEMP*  
*FUEL STORAGE*  
*FUEL FLOW*  
*FUEL PRESSURE*  
*H2O COOLING PRESSURE/FLOW*

AVAILABILITY:

TEST FREQUENCY:

COST(\$/DAY):

SETUP/COORDINATION COST:

INSTRUMENTATION

SAMPLING

    PROBES:

    LINES:

OTHER REMARKS:

CONTACT: Roquemore

**SECTOR/FLAMETUBE TEST FACILITIES AND CAPABILITIES**

## VENUES FOR PARTICULATES/AEROSOLS MEASUREMENTS

ORGANIZATION: NASA LeRC

FACILITY: ECRL 1B

TEST HARDWARE: Sector and Full Annular

CONDITIONS:       PRESSURE 165 psia  
                  TEMP ambient-620°F non-vitiated; 2000°F vitiated  
                  FLOW 250 pps  
                  VITIATED OR NON-VITIATED both  
                  EXIT TEMP 4000°F  
                  ATM OR ALT EXHAUST both  
                  OTHER

*HEATER TYPE Non-vitiated: natural gas; Vitiated: J-58*

*OTHER HEATER PRESSURE/TEMP*

*FUEL STORAGE (2) 20,000 gal tanks, (2) 10,000 gal tanks*

*FUEL TYPE*

*FUEL FLOW 70 gpm*

*FUEL PRESSURE 75 psig*

*FUEL DISTRIBUTION*

*H2O COOLING PRESSURE/FLOW 1200 gpm/160 psig*

AVAILABILITY: Ready for occupancy in June 1998

TEST FREQUENCY: daily

COST(\$/DAY): \$1000/day + \$55/Megawatt Hr

SETUP/COORDINATION COST:

INSTRUMENTATION

Standard Gas Analyzers: CO, CO<sub>2</sub>, NO, NO<sub>x</sub>, O<sub>2</sub>, UHC;

Smoke meter, particle measurement system

SAMPLING

PROBES: 8 pitots, gas sampling on one probe; Probe actuated +/- 30° from vertical can give exhaust gas profile

LINES: Heated

OTHER REMARKS:

CONTACT: Technical - Gary Huber (216) 433-5688

(Acting) Facility Manager - Bob Freedman (216) 433-2038

VENUES FOR PARTICULATES/AEROSOLS MEASUREMENTS

ORGANIZATION: NASA LeRC

FACILITY: ECRL 2A

TEST HARDWARE: Sector and Full Annular

CONDITIONS:      PRESSURE 150 psia  
                    TEMP 600°F or 700-2500°F  
                    FLOW 31.0 pps  
                    VITIATED OR NON-VITIATED vitiated  
                    EXIT TEMP  
                    ATM OR ALT EXHAUST  
                    OTHER

*HEATER TYPE J-47 vitiated*

*OTHER HEATER PRESSURE/TEMP*

*FUEL STORAGE (2) 20,000 gal tanks and (2) 10,000 gal tanks*

*FUEL TYPE Jet A or JP-5 for J-47 and J-58 or natural gas for J-47*

*FUEL FLOW 10 GPM*

*FUEL PRESSURE 500-600 psig*

*FUEL DISTRIBUTION*

*H2O COOLING PRESSURE/FLOW 600 GPM/150 psig*

AVAILABILITY:

TEST FREQUENCY:

COST(\$/DAY):

SETUP/COORDINATION COST:

INSTRUMENTATION

SAMPLING

PROBES:

LINES:

OTHER REMARKS:

CONTACT: Technical - Queito Thomas (216) 433-3700  
(Acting) Facility Manager - Bob Freedman (216) 433-2038

## VENUES FOR PARTICULATES/AEROSOLS MEASUREMENTS

ORGANIZATION: NASA LeRC

FACILITY: RL-23

TEST HARDWARE: Flametube

CONDITIONS:      PRESSURE 90 psia  
                    TEMP      1400°F  
                    FLOW      0.5-1.0 pps  
                    VITIATED OR NON-VITIATED non-vitiated  
                    EXIT TEMP 3000°F  
                    ATM OR ALT EXHAUST atm  
                    OTHER      2000 psig N2

*HEATER TYPE shell and tube*  
*OTHER HEATER PRESSURE/TEMP 1.2 pps, 90 psig, 1500°F*  
*FUEL STORAGE (1) 300 gal tank; (1) 600 gal tank; (1) 1000 gal tank*  
*FUEL FLOW 1.5 gpm*  
*FUEL TYPE JP-8*  
*FUEL PRESSURE 480 psig*  
*FUEL DISTRIBUTION*  
*H2O COOLING PRESSURE/FLOW 25 gpm/100 psig*

### AVAILABILITY:

TEST FREQUENCY: 2 days/week

COST(\$/DAY): \$55/Megawatt Hr; 3 person crew(\$500/day); or cost/occupancy  
hour of \$571

SETUP/COORDINATION COST: \$3K-\$300K

### INSTRUMENTATION

Standard gas analyzers: CO, CO<sub>2</sub>, NO, NO<sub>x</sub>, O<sub>2</sub>, UHC

Particle measurement system

### SAMPLING

PROBES: SS, water cooled probes, multi port; 1 stationary and 1 actuated;  
located at axial distances of 4", 6", and 8" downstream of the combustion section  
inlet flange

LINES: Electrically heated

### OTHER REMARKS:

CONTACT: Technical - Dave Hulligan (216) 433-6629  
Facility Manager - Jeff Swan (216) 433- 5434

## VENUES FOR PARTICULATES/AEROSOLS MEASUREMENTS

ORGANIZATION: NASA LeRC

FACILITY: CE-5

TEST HARDWARE: Flametube and Sector

CONDITIONS: PRESSURE 450 psig(Rig pressure without windows up to 1100°F - Stand 1: 275 psig, Stand 2: 400 psig; rig pressure with windows up to 3200°F flame temp - Stand 1: 250 psig, Stand 2: 400 psig)  
TEMP 350-1100°F  
FLOW: Stand 1: 1-20 pps; Stand 2: 0-3 pps  
VITIATED OR NON-VITIATED non-vitiated  
EXIT TEMP 3200°F  
ATM OR ALT EXHAUST atm; 20" Hg or 26" Hg alt  
OTHER  
NITROGEN: 0.5 pps/335 psig; 4 legs

*HEATER TYPE shell and tube*  
*OTHER HEATER PRESSURE/TEMP 20 pps, 40 psig, 1400°F*  
*FUEL STORAGE (2) 600 gal tanks*  
*FUEL TYPE JP8*  
*FUEL FLOW 6.0 gpm*  
*FUEL PRESSURE 900 psig*  
*FUEL DISTRIBUTION 3 separate legs*  
*H2O COOLING PRESSURE/FLOW 15 gpm/55 psig;*  
*150 gpm/460 psig; 50 gpm/350 psig; 250 gpm/395 psig*

AVAILABILITY:

TEST FREQUENCY: 2-3 days/week

COST(\$/DAY): cost/occupancy hour - stand 1: \$714, stand 2 - \$713

SETUP/COORDINATION COST:

INSTRUMENTATION

Standard Gas Analyzers; particle measurement system;  
Non-intrusive laser diagnostics: YAG pumped dye laser systems with wave length extension systems for obtaining UV light, Measurements include: planar mi scattering, phase doppler particle analysis(PDPA), LDV/PDPA, laser induced fluorescence(LIF), planar laser induced fluorescence(PLIF), RAMAN, SCHLIEREN, C2 FLUORESCENCE; Acoustics, Smokemeter(filter paper), Gas Chromatograph/Mass Spectrometer(GCMS); Acoustics



## VENUES FOR PARTICULATES/AEROSOLS MEASUREMENTS

ORGANIZATION: NASA LeRC  
FACILITY: CE-5(CONTINUED)

### SAMPLING

PROBES: stand 1: 1 movable probe with 1 port, 5 stationary probes with 5-7 ports, located at 5 5/8" downstream of injector flange; SS, water cooled probe; stand 2: 1 traversing probe with single port; stationary probes with 3 or 5 ports; SS, water cooled probes, axial locations downstream of injector flange - without windows: 4", 12" and 20", with windows: 5 5/8"

LINES: Inner liner material: stand 2-teflon; stand 1-SS; Line length: stand 2-100 ft; Electrically heated lines with steam tracing at analyzers

### OTHER REMARKS:

CONTACT: Technical - STD 1: Joe Morgan (216) 433-5647  
STD 2: Hamilton Fernandez (216) 433-5745  
Facility Manager - Jeff Swan (216) 433-5434

## VENUES FOR PARTICULATES/AEROSOLS MEASUREMENTS

ORGANIZATION: NASA LeRC

FACILITY: CE-9

TEST HARDWARE: Flametube and Sector

CONDITIONS:        PRESSURE 450 psig  
                      TEMP        1050°F  
                      FLOW        15 pps  
                      VITIATED OR NON-VITIATED non-vitiated  
                      EXIT TEMP 3500°F  
                      ATM OR ALT EXHAUST atm or alt  
                      OTHER -

*HEATER TYPE shell and tube*  
*OTHER HEATER PRESSURE/TEMP 15 pps, 40 psig, 1400°F*  
*FUEL STORAGE (1) 5000 gal tank*  
*FUEL TYPE*  
*FUEL FLOW 11 gpm*  
*FUEL PRESSURE 900 psig*  
*H2O COOLING PRESSURE/FLOW 175 gpm/550 psig;*  
*135 gpm/835 psig;*  
*42 gpm/60 psig*

AVAILABILITY:

TEST FREQUENCY:

COST(\$/DAY): cost/occupancy hour: rig A: \$862, rig B: \$707

SETUP/COORDINATION COST:

INSTRUMENTATION

Standard Gas Analyzers: CO, CO<sub>2</sub>, NO, NO<sub>x</sub>, O<sub>2</sub>, UHC

SAMPLING

PROBES: Water cooled

LINES: Electrically heated; Inner Liner Material - Smooth SS

OTHER REMARKS:

CONTACT: Technical - Bob Ehlers (216) 433-5707  
                  Facility Manager - Jeff Swan (216) 433-5434

## VENUES FOR PARTICULATES/AEROSOLS MEASUREMENTS

ORGANIZATION: NASA LeRC

FACILITY: ASCR

TEST HARDWARE: Flametube, Sector, and Regional Engine Full Annular

CONDITIONS: PRESSURE 900 psia  
TEMP 1300°F  
FLOW 3-12 pps Flametube; 3-38 pps Sector/Full Annular  
VITIATED OR NON-VITIATED non-vitiated  
EXIT TEMP 3200°F  
ATM OR ALT EXHAUST atm  
OTHER  
NITROGEN: 2000 psig

HEATER TYPE *shell and tube*  
OTHER HEATER PRESSURE/TEMP *50 pps, 150 psig,  
1700°F*

FUEL STORAGE (1) *20,000 gal tank*  
FUEL TYPE *Jet A*  
FUEL FLOW *20 gpm*  
FUEL PRESSURE *2000 psig*  
H2O COOLING PRESSURE/FLOW *3000 gpm/60 psig;  
670 gpm/250 psig;  
300 gpm/1500 psig*

### AVAILABILITY:

TEST FREQUENCY: 2 days/week

COST(\$/DAY): 450 psia air only - \$2K; 1250 psia air, flow less than 25 pps - \$6-10K;  
1250 psia air, flow more than 25 pps - \$10-16K; cost/occupancy hour: \$2,092

SETUP/COORDINATION COST: Flametube - assy \$600, installation \$240, +  
instrumentation; Sector - unknown at this time

### INSTRUMENTATION

Standard Gas Analyzers: CO, CO2, NO, NOx, O2, UHC;

Smoke meters - 1 filter type and 1 optical; particle measurement system

Non-intrusive laser diagnostics: YAG pumped dye laser systems with wave  
length extension systems for obtaining UV light, Measurements include: planar mi  
scattering, phase doppler particle analysis(PDPA), LDV/PDPA, laser induced  
flourescence(LIF), planar laser induced flourescence(PLIF), RAMAN,  
SCHLIEREN, C2 FLUORESCENCE; Acoustics

VENUES FOR PARTICULATES/AEROSOLS MEASUREMENTS

ORGANIZATION: NASA LeRC  
FACILITY: ASCR(CONTINUED)

SAMPLING

PROBES: SS, Water cooled, multi port; 2 probes can be used simultaneously in Flametube at axial locations 2.4", 4.5", 6.0", 7.5", 9.0", 11.0", 16", and 22" downstream of the combustion section inlet flange; 21 sampling lines are available for the Sector rig

LINES: Steam traced and Electrically heated; Inner Liner Material: First 12 ft are carbon black teflon, remainder is SS; Line Length: 100-120 ft

OTHER REMARKS:

CONTACT: Technical - Pete Pachlhofer (216) 433-5705  
Facility Manager - Jeff Swan (216) 433-5434

## VENUES FOR PARTICULATES/AEROSOLS MEASUREMENTS

ORGANIZATION: Allison Engine Company

FACILITY: Combustor Research Lab

TEST HARDWARE: Flametube concepts

CONDITIONS: PRESSURE 2 lines - low pressure 100 psia, high pressure  
300 psia

TEMP 800-900°F, or 1300°F with electric heater

FLOW 10 pps at 100 psia, 5 pps at 300 psia

VITIATED OR NON-VITIATED

EXIT TEMP

ATM OR ALT EXHAUST

OTHER:

NATURAL GAS 300 psig

*HEATER TYPE air to air heat exchanger, electric emersion*

*HEATER PRESSURE/TEMP*

*FUEL STORAGE 1500 gal tank*

*FUEL FLOW 1000 pph*

*FUEL PRESSURE 1000 psig*

*H2O COOLING PRESSURE/FLOW 3000 pph/400, 500 psig*

AVAILABILITY:

TEST FREQUENCY:

COST(\$/DAY):

SETUP/COORDINATION COST:

INSTRUMENTATION

Standard gas analyzers(Fisher and Rosemount), Malvern Particle Size Analyzer

SAMPLING

PARTICULATES/AEROSOLS measurements were made 6-7 yrs ago on cold fuels(solid fuel), focus on combustion efficiency - solid residue was captured and analyzed for ash and carbon content(ash analyzer and particle counter + photo micrographs); special probes - 1 foot long with larger ports were used to collect particulate, SS H2O cooled probes that sampled at the same velocity as the gas stream, H2O was injected into the sample; collected the particulates through filter paper in a tank a few feet away, the tank had a water separator and flow meter

PROBES: H2O cooled, SS probes, axial location varies with each rig, .020" port size, single cup rig has sampling port 8" downstream of fuel injector with a flow path of 4"x4", two types of probes - fixed multi-port and an actuated single port; 3 probes located in one plane at different radial locations

**VENUES FOR PARTICULATES/AEROSOLS MEASUREMENTS**

**ORGANIZATION:** Allison Engine Company  
**FACILITY:** Combustor Research Lab(continued)  
**TEST HARDWARE:** Flametube concepts  
**LINES:** Electrically heated  
**OTHER REMARKS:**

**CONTACT:** John Rothrock (317) 230-3057

## VENUES FOR PARTICULATES/AEROSOLS MEASUREMENTS

ORGANIZATION: Allison Engine Company  
FACILITY: Test Department Combustor Facility  
TEST HARDWARE: Flametube, Sector and Full Annular

CONDITIONS:  
PRESSURE  
TEMP  
FLOW  
VITIATED OR NON-VITIATED  
EXIT TEMP  
ATM OR ALT EXHAUST  
OTHER:

*HEATER TYPE*  
*HEATER PRESSURE/TEMP*  
*FUEL STORAGE*  
*FUEL FLOW*  
*FUEL PRESSURE*  
*H2O COOLING PRESSURE/FLOW*

AVAILABILITY:  
TEST FREQUENCY:  
COST(\$/DAY):  
SETUP/COORDINATION COST:  
INSTRUMENTATION  
SAMPLING  
PROBES:  
LINES:  
OTHER REMARKS:

CONTACT: Ron Mutzl (317) 230-4702  
John Spratt (317) 230-2106

**VENUES FOR PARTICULATES/AEROSOLS MEASUREMENTS**

**ORGANIZATION:** General Electric - Evandale

**FACILITY:** Cell A18

**TEST HARDWARE:** HP Sector, HP Annular Combustors  
Emissions and Altitude Relight Testing

**CONDITIONS:**      **PRESSURE** 440 psia(30 ATM)  
                          **TEMP**      1140°F(1600°R)  
                          **FLOW**      200 pps  
                          **VITIATED OR NON-VITIATED**  
                          **EXIT TEMP**  
                          **ATM OR ALT EXHAUST**  
                          **OTHER**

*HEATER TYPE*  
*HEATER PRESSURE/TEMP*  
*FUEL STORAGE*  
*FUEL FLOW*  
*FUEL PRESSURE*  
*H2O COOLING PRESSURE/FLOW*

**AVAILABILITY:**

**TEST FREQUENCY:**

**COST(\$/DAY):**

**SETUP/COORDINATION COST:**

**INSTRUMENTATION**

**SAMPLING**

**PROBES:**

**LINES:**

**OTHER REMARKS:**

**CONTACT:** Claude Chauvette (513) 243-2626



## VENUES FOR PARTICULATES/AEROSOLS MEASUREMENTS

ORGANIZATION: General Electric - Evandale

FACILITY: Cell A19

TEST HARDWARE: HP Flametube, HP Single Module, LP Sector, LP Annular  
Combustors  
Emissions and Altitude Relight and Exit Temperature Profile  
Testing

CONDITIONS: PRESSURE 440 psia(30 ATM)  
TEMP 1040°F(1500°R)  
FLOW 45 pps  
VITIATED OR NON-VITIATED  
EXIT TEMP  
ATM OR ALT EXHAUST  
OTHER

*HEATER TYPE  
HEATER PRESSURE/TEMP  
FUEL STORAGE  
FUEL FLOW  
FUEL PRESSURE  
H2O COOLING PRESSURE/FLOW*

AVAILABILITY:

TEST FREQUENCY:

COST(\$/DAY):

SETUP/COORDINATION COST:

INSTRUMENTATION

SAMPLING

PROBES:

LINES:

OTHER REMARKS:

CONTACT: Claude Chauvette (513) 243-2626

**VENUES FOR PARTICULATES/AEROSOLS MEASUREMENTS**

**ORGANIZATION:** General Electric - Evandale

**FACILITY:** Cell A5

**TEST HARDWARE:** MP Flametube, LP Single Module, LP Sector, LP Annular  
Combustors  
Emissions, Exit Temperature Profile, LBO Testing

**CONDITIONS:** PRESSURE 220 psia(15 ATM)  
TEMP 1140°F(1600°R)  
FLOW 10 pps  
VITIATED OR NON-VITIATED  
EXIT TEMP  
ATM OR ALT EXHAUST  
OTHER

*HEATER TYPE*  
*HEATER PRESSURE/TEMP*  
*FUEL STORAGE*  
*FUEL FLOW*  
*FUEL PRESSURE*  
*H2O COOLING PRESSURE/FLOW*

**AVAILABILITY:**

**TEST FREQUENCY:**

**COST(\$/DAY):**

**SETUP/COORDINATION COST:**

**INSTRUMENTATION**

**SAMPLING**

**PROBES:**

**LINES:**

**OTHER REMARKS:**

**CONTACT:** Claude Chauvette (513) 243-2626

## VENUES FOR PARTICULATES/AEROSOLS MEASUREMENTS

ORGANIZATION: General Electric - Evandale

FACILITY: Cell 306

TEST HARDWARE: LP Flametube, LP Single Module, LP Sector  
Emissions, Altitude Relight, Exit Temperature Profile and LBO  
Testing

CONDITIONS: .PRESSURE 118 psia(8 ATM)  
TEMP 740°F(1200°R)  
FLOW 10 pps  
VITIATED OR NON-VITIATED  
EXIT TEMP  
ATM OR ALT EXHAUST  
OTHER

*HEATER TYPE*  
*HEATER PRESSURE/TEMP*  
*FUEL STORAGE*  
*FUEL FLOW*  
*FUEL PRESSURE*  
*H2O COOLING PRESSURE/FLOW*

AVAILABILITY:

TEST FREQUENCY:

COST(\$/DAY):

SETUP/COORDINATION COST:

INSTRUMENTATION

SAMPLING

PROBES:

LINES:

OTHER REMARKS:

CONTACT: Claude Chauvette (513) 243-2626

## VENUES FOR PARTICULATES/AEROSOLS MEASUREMENTS

ORGANIZATION: United Technologies Research Center(UTRC)  
FACILITY: Jet Burner Test Stand(JBTS) - Ambient pressure single-injector flametube  
TEST HARDWARE: Ambient pressure single-injector flametube

CONDITIONS:      PRESSURE 44 psia/ 400 psia/ 600 psia  
                      TEMP        400°F / 850°F / 850°F  
                      FLOW        17 pps/ 20 pps / 4 pps  
                      VITIATED OR NON-VITIATED vitiated and non-vitiated  
                      EXIT TEMP  
                      ATM OR ALT EXHAUST  
                      OTHER  
                                  HYDROGEN 2400 psi  
                                  OXYGEN 2400 psi  
                                  NITROGEN 2400 psi

### *HEATER TYPE*

*HEATER PRESSURE/TEMP*

*FUEL STORAGE (3) 1000 gal, (3) 4000 gal; (1) 10,000 gal tank*

*FUEL FLOW 35 GPM*

*FUEL PRESSURE 1500 psi*

*H2O COOLING PRESSURE/FLOW 700 psi*

AVAILABILITY:

TEST FREQUENCY:

COST(\$/DAY):

SETUP/COORDINATION COST:

INSTRUMENTATION

Standard gas analyzers: CO, CO<sub>2</sub>, NO, NO<sub>x</sub>, O<sub>2</sub>, UHC

SAMPLING

PROBES: 3 H<sub>2</sub>O cooled sampling probe rakes are located at the exit of the combustor; (4) 0.64 mm orifices span each sampling rake. Emissions can be acquired individually or for all three rakes simultaneously

LINES: Heated pump, electrically heated sample transfer lines

OTHER REMARKS:

CONTACT: Charlie Graves (407) 796-5289

## VENUES FOR PARTICULATES/AEROSOLS MEASUREMENTS

ORGANIZATION: United Technologies Research Center(UTRC)

FACILITY: Jet Burner Test Stand(JBTS) - Moderate pressure single-injector flametube

TEST HARDWARE: Moderate pressure single-injector flametube

CONDITIONS:      PRESSURE 200 psia  
                    TEMP        900°F  
                    FLOW        20 pps  
                    VITIATED OR NON-VITIATED non-vitiated  
                    EXIT TEMP  
                    ATM OR ALT EXHAUST  
                    OTHER  
                            HYDROGEN 2400 psi  
                            OXYGEN 2400 psi  
                            NITROGEN 2400 psi

### *HEATER TYPE*

*HEATER PRESSURE/TEMP*

*FUEL STORAGE (3) 1000 gal, (3) 4000 gal; (1) 10,000 gal tank*

*FUEL FLOW 35 GPM*

*FUEL PRESSURE 1500 psi*

*H2O COOLING PRESSURE/FLOW 700 psi*

AVAILABILITY:

TEST FREQUENCY:

COST(\$/DAY):

SETUP/COORDINATION COST:

INSTRUMENTATION

Standard gas analyzers: CO, CO<sub>2</sub>, NO, NO<sub>x</sub>, O<sub>2</sub>, UHC; Smokemeter

SAMPLING

PROBES: Piccolo probe system at the combustor exit; a series of seven probes spanning the exit plane. Each piccolo probe has seven gas sampling ports with 0.30 in. orifices. The assembly can be sampled as a gang system or from each piccolo probe.

LINES:

OTHER REMARKS:

CONTACT: Charlie Graves (407) 796-5289

VENUES FOR PARTICULATES/AEROSOLS MEASUREMENTS

ORGANIZATION: Southwest

FACILITY:

TEST HARDWARE:

CONDITIONS:      PRESSURE 150 PSIA (10 ATM)  
                    TEMP        1200°F  
                    FLOW        3 PPS  
                    VITIATED OR NON-VITIATED  
                    EXIT TEMP  
                    ATM OR ALT EXHAUST  
                    OTHER  
                            HYDROGEN  
                            OXYGEN  
                            NITROGEN

*HEATER TYPE*  
*HEATER PRESSURE/TEMP*  
*FUEL STORAGE*  
*FUEL FLOW*  
*FUEL PRESSURE*  
*H2O COOLING PRESSURE/FLOW*

AVAILABILITY:

TEST FREQUENCY:

COST(\$/DAY):

SETUP/COORDINATION COST:

INSTRUMENTATION

SAMPLING

    PROBES:

    LINES:

OTHER REMARKS:

CONTACT:

## VENUES FOR PARTICULATES/AEROSOLS MEASUREMENTS

ORGANIZATION: University of California at Irvine

FACILITY:

TEST HARDWARE:

CONDITIONS: PRESSURE 225 PSIA (15 ATM)

TEMP 1200°F

FLOW 1-4 PPS

VITIATED OR NON-VITIATED

EXIT TEMP

ATM OR ALT EXHAUST

OTHER

HYDROGEN

OXYGEN

NITROGEN

*HEATER TYPE*

*HEATER PRESSURE/TEMP*

*FUEL STORAGE*

*FUEL FLOW*

*FUEL PRESSURE*

*H2O COOLING PRESSURE/FLOW*

AVAILABILITY:

TEST FREQUENCY:

COST(\$/DAY):

SETUP/COORDINATION COST:

INSTRUMENTATION

SAMPLING

PROBES:

LINES:

OTHER REMARKS:

CONTACT: Vince McDonell (714) 824-7423

**FUNDAMENTAL/EXPERIMENTAL TEST FACILITIES AND CAPABILITIES  
(SHOCK TUBE/SHOCK TUNNEL/STIRRED REACTOR)**



VENUES FOR PARTICULATES/AEROSOLS MEASUREMENTS

ORGANIZATION: Wright Patterson Air Force Base

FACILITY:

TEST HARDWARE:

CONDITIONS:      PRESSURE  
                      TEMP  
                      FLOW  
                      VITIATED OR NON-VITIATED  
                      EXIT TEMP  
                      ATM OR ALT EXHAUST  
                      OTHER  
                          HYDROGEN  
                          OXYGEN  
                          NITROGEN

*HEATER TYPE*  
*HEATER PRESSURE/TEMP*  
*FUEL STORAGE*  
*FUEL FLOW*  
*FUEL PRESSURE*  
*H2O COOLING PRESSURE/FLOW*

AVAILABILITY:

TEST FREQUENCY:

COST(\$/DAY):

SETUP/COORDINATION COST:

INSTRUMENTATION

SAMPLING

    PROBES:

    LINES:

OTHER REMARKS:

CONTACT: Roquemore

VENUES FOR PARTICULATES/AEROSOLS MEASUREMENTS

ORGANIZATION: NASA LeRC  
FACILITY: Basic Combustion Lab  
TEST HARDWARE:

CONDITIONS: PRESSURE  
TEMP  
FLOW  
VITIATED OR NON-VITIATED  
EXIT TEMP  
ATM OR ALT EXHAUST  
OTHER  
HYDROGEN  
OXYGEN  
NITROGEN

*HEATER TYPE*  
*HEATER PRESSURE/TEMP*  
*FUEL STORAGE*  
*FUEL FLOW*  
*FUEL PRESSURE*  
*H2O COOLING PRESSURE/FLOW*

AVAILABILITY:  
TEST FREQUENCY:  
COST(\$/DAY):  
SETUP/COORDINATION COST:  
INSTRUMENTATION  
SAMPLING  
PROBES:  
LINES:  
OTHER REMARKS:  
  
CONTACT:

APPENDIX

INFORMATION FROM ARI-RR-947

“Engine Trace Constituent Measurements Recommended for the Assessment of the  
Atmospheric Effects of Stratospheric Aircraft”

by

R.C. Miake-Lye, W.J. Dodds, D.W. Fahey, C.E. Kolb and S.R. Langhoff  
August 1992



## ATTENDEES LIST

### **Bruce Anderson**

NASA Langley Research Center  
MS 483  
Hampton VA 23681-0001

Workphone 757/864-5850  
Workfax 757/864-5841  
E-mail b.e.anderson@larc.nasa.gov

### **Steve Baughcum**

The Boeing Company  
MS 6H-FC  
PO Box 3707  
Seattle WA 98124-2499

Workphone 425/965-0426  
Workfax 425/234-4543  
E-mail baughcum@atc.boeing.com

### **Jean Bianco**

NASA Lewis Research Center  
21000 Brookpark Road  
MS 6-9  
Cleveland OH 44135

Workphone 216/433-8870  
Workfax 216/433-5100  
E-mail jean.bianco@lerc.nasa.gov

### **Pratim Biswas**

University of Cincinnati  
Department of Aerospace Engineering  
Aerosol & Air Quality Research Lab, ML 71  
Cincinnati OH 45221-0071

Workphone 513/556-3697  
Workfax 513/556-2599  
E-mail pratim.biswas@uc.edu

### **Kevin Breisacher**

NASA Lewis Research Center  
21000 Brookpark Road  
MS 60-4  
Cleveland OH 44135

Workphone 216/977-7475  
Workfax 216/977-7545  
E-mail kevin.breisacher@lerc.nasa.gov

### **Daniel Briehl**

NASA Lewis Research Center  
21000 Brookpark Road  
MS 77-10  
Cleveland OH 44135

Workphone 216/433-6108  
Workfax 216/433-3954  
E-mail daniel.briehl@lerc.nasa.gov

### **Daniel Bulzan**

NASA Lewis Research Center  
21000 Brookpark Road  
MS 5-11  
Cleveland OH 44135

Workphone 216/433-5848  
Workfax 216/433-5802  
E-mail dan.l.bulzan@lerc.nasa.gov

### **Kaz Civinskis**

ARL/NASA Lewis Research Center  
21000 Brookpark Road  
Cleveland OH 44135

Workphone 216/433-5890  
Workfax  
E-mail

### **Michael Coggiola**

SRI International  
Molecular Physics Laboratory  
333 Ravenswood Avenue  
Menlo Park CA 94025

Workphone 415/859-3045  
Workfax 415/859-6196  
E-mail coggiola@mplvax.sri.com

### **Renato Colantonio**

NASA Lewis Research Center  
21000 Brookpark Road  
MS 500-115  
Cleveland OH 44135

Workphone 216/433-6370  
Workfax 216/433-8660  
E-mail renato.o.colantonio@lerc.nasa.gov

**Larry Diehl**

NASA Lewis Research Center  
21000 Brookpark Road  
MS 3-5  
Cleveland OH 44135

Workphone 216/977-7505  
Workfax  
E-mail larry.diehl@lerc.nasa.gov

**Will Dodds**

GE Aircraft Engines  
One Neumann Way  
Cincinnati OH 45215

Workphone 513/243-0504  
Workfax 513/243-2541  
E-mail willard.dodds@ae.ge.com

**Fred Dryer**

Princeton University  
316 Engineering Quadrangle  
Princeton NJ 08544-5263

Workphone 609/258-5206  
Workfax 609/258-1939  
E-mail fldryer@phoenix.princeton.edu

**Tyler Evans**

Pratt & Whitney  
PO Box 109600  
West Palm Beach FL 33410-9600

Workphone 561/796-8312  
Workfax 561/796-6242  
E-mail evanstyl@pwfl.com

**Gus Fralick**

NASA Lewis Research Center  
21000 Brookpark Road  
MS 77-1  
Cleveland OH 44135

Workphone 216/433-3645  
Workfax 216/433-8643  
E-mail gustave.c.fralick@lerc.nasa.gov

**Suleyman Gokoglu**

NASA Lewis Research Center  
21000 Brookpark Road  
MS 500-115  
Cleveland OH 44135

Workphone 216/433-5499  
Workfax  
E-mail suleyman.gokoglu@lerc.nasa.gov

**Sol Gorland**

NASA Lewis Research Center  
21000 Brookpark Road  
MS 60-4  
Cleveland OH 44135

Workphone 216/977-7961  
Workfax 216/977-7500  
E-mail sol.h.gorland@lerc.nasa.gov

**Charles Graves**

Pratt & Whitney  
194 Jones Creek Drive  
Jupiter FL 33458

Workphone 561/796-5289  
Workfax 561/796-6242  
E-mail

**Donald Hagen**

University of Missouri-Rolla  
Cloud and Aerosol Sciences Laboratory  
G-7 Norwood Hall  
Rolla MO 65401-0249

Workphone 573/341-4351  
Workfax 573/341-4891  
E-mail hagen@umr.edu

**William Harrison**

US Air Force  
WL/POSF, Bldg. 490  
1790 Loop Road North  
Wright Patterson OH 45433-7103

Workphone 937/255-6601  
Workfax 937/255-1125  
E-mail harriswe@wl.wpafb.af.mil

**Bob Hiers**

AEDC  
Sverdrup Technology, Inc.  
1099 Avenue C  
Arnold AFB TN 37389-9013

Workphone 615/454-3957  
Workfax 615/454-4913  
E-mail hiersb@hap.arnold.af.mil

**James Holdeman**

NASA Lewis Research Center  
21000 Brookpark Road  
MS 77-10  
Cleveland OH 44135

Workphone 216/433-5846  
Workfax 216/433-3954  
E-mail james.d.holdeman@lerc.nasa.gov

**Robert Howard**  
AEDC  
Sverdrup Technology, Inc.  
1099 Avenue C  
Arnold AFB TN 37389-9013  
Workphone 615/454-4783  
Workfax 615/454-4913  
E-mail howard@hap.arnold.af.mil

**Paul Kang**  
DOT/FAA  
800 Independence Avenue, S.W., AEE-110  
Washington, DC 20591  
Workphone 202/267-3566  
Workfax 202/267-5594  
E-mail pkang@mail.hq.faa.gov

**Andrew Hsu**  
Allison Engine Company  
Speed Code T-14  
PO Box 420  
Indianapolis IN 46206-0420  
Workphone 317/230-6195  
Workfax  
E-mail aeath@agt.gmeds.com

**S. Randy Kawa**  
NASA Goddard Space Flight Center  
Code 916  
Greenbelt MD 20771-0001  
Workphone 301/286-5656  
Workfax 301/286-1662  
E-mail kawa@maia.gsfc.nasa.gov

**Gary Hunter**  
NASA Lewis Research Center  
21000 Brookpark Road  
MS 77-1  
Cleveland OH 44135  
Workphone 216/433-6459  
Workfax 216/433-8643  
E-mail gary.w.hunter@lerc.nasa.gov

**Theo Keith**  
Ohio Aerospace Institute  
22800 Cedar Point Road  
Cleveland OH 44142  
Workphone 216/962-3030  
Workfax 216/962-3120  
E-mail tedkeith@oai.org

**Harjit Hura**  
GE Aircraft Engines  
One Neumann Way  
Cincinnati OH 45215  
Workphone 513/243-0393  
Workfax  
E-mail

**Prem Khosla**  
University of Cincinnati  
Department of Aerospace Engineering  
ML 70  
Cincinnati OH 45221-0071  
Workphone 513/556-3551  
Workfax 513/556-5038  
E-mail pkhosla@uceng.uc.edu

**Richard Jaffe**  
NASA Ames Research Center  
MS 230-3  
Moffett Field CA 94035  
Workphone 415/604-6458  
Workfax 415/604-0350  
E-mail rjaffe@mail.arc.nasa.gov

**Chuck Kolb**  
Aerodyne Research, Inc.  
Center for Chem. & Env. Physics  
45 Manning Road  
Billerica MA 01821-3976  
Workphone 508/663-9500x290  
Workfax 508/663-4918  
E-mail kolb@aerodyne.com

**San-Mou Jeng**  
University of Cincinnati  
Department of Aerospace Engineering  
484 ERC  
Cincinnati OH 45140  
Workphone 513/556-3361  
Workfax 513/556-5038  
E-mail smjeng@rocket.ase.uc.edu

**Allen Koller**  
GE Aircraft Engines  
MS H78  
One Neumann Way  
Cincinnati OH 45215  
Workphone 513/243-0555  
Workfax 513/786-4592  
E-mail allen.koller@ae.ge.com

**Krishna Kundu**

NASA Lewis Research Center  
21000 Brookpark Road  
MS 77-10  
Cleveland OH 44135

Workphone 216/433-3937  
Workfax 216/433-3954  
E-mail krishna.kundu@lerc.nasa.gov

**Richard Lawrence**

NASA Goddard Space Flight Center  
Building 21  
Greenbelt MD 20771-0001

Workphone 301/286-1022  
Workfax 301/286-1704  
E-mail rlawrence@pop400.gsfc.nasa.gov

**Chi-Ming Lee**

NASA Lewis Research Center  
21000 Brookpark Road  
MS 77-10  
Cleveland OH 44135

Workphone 216/433-3413  
Workfax 216/433-3954  
E-mail chi-ming.lee@lerc.nasa.gov

**Jinho Lee**

NASA Lewis Research Center  
21000 Brookpark Road  
MS 5-11  
Cleveland OH 44135

Workphone 216/433-5877  
Workfax  
E-mail fsjinho@lerc.nasa.gov

**Jih-Fen Lei**

NASA Lewis Research Center  
21000 Brookpark Road  
MS 77-1  
Cleveland OH 44135

Workphone 216/433-3922  
Workfax 216/433-8643  
E-mail jih-fen.lei@lerc.nasa.gov

**Harvey Lilienfeld**

McDonnell Douglas Corporation  
PO Box 516  
MS 111-1041  
Saint Louis MO 63166-0516

Workphone 314/233-2550  
Workfax 314/232-0888  
E-mail lilienfeld@mdc.com

**Diane Linne**

NASA Lewis Research Center  
21000 Brookpark Road  
MS 60-4  
Cleveland OH 44135

Workphone 216/433-7512  
Workfax  
E-mail diane.linne@lerc.nasa.gov

**David Liscinski**

United Technologies Research Center  
411 Silver Lane, MS 30  
East Hartford CT 06108

Workphone 860/610-7936  
Workfax 860/610-2151  
E-mail liscinds@utrc.utc.com

**Robert Lohmann**

Pratt & Whitney  
PO Box 109600  
West Palm Beach FL 33410-9600

Workphone 516/796-4964  
Workfax 561/796-6242  
E-mail

**Valerie Lyons**

NASA Lewis Research Center  
21000 Brookpark Road  
MS 77-10  
Cleveland OH 44135

Workphone 216/433-5970  
Workfax 216/433-3954  
E-mail vlyons@lerc.nasa.gov

**Robert Mantz**

Wright Patterson AFB  
Fuels Branch  
1790 Loop Road North, Bldg. 490  
Wright Patterson OH 45433-7103

Workphone 937/255-7423  
Workfax 937/255-1125  
E-mail mantzra@wl.wpafb.af.mil

**C. John Marek**

NASA Lewis Research Center  
21000 Brookpark Road  
MS 5-11  
Cleveland OH 44135

Workphone 216/433-3584  
Workfax 216/433-3000  
E-mail cecil.j.marek@lerc.nasa.gov



**William Marlow**  
Texas A&M University  
Nuclear Engineering Department  
College Station TX 77843-3133  
Workphone 406/845-2271  
Workfax 409/845-6443  
E-mail whm2384@acs.tamu.edu

**Charles Martin**  
NASA Lewis Research Center  
21000 Brookpark Road  
Cleveland OH 44135  
Workphone 216/433-3588  
Workfax  
E-mail charles.martin@lerc.nasa.gov

**Vince McDonell**  
University of California - Irvine  
UCI Combustion Lab  
Irvine CA 92697  
Workphone 714/824-3652  
Workfax 714/824-7423  
E-mail mcdonell@ucicl.eng.uci.edu

**Edward McQueen**  
Federal Aviation Administration  
800 Independence Avenue, S.W.  
Washington, DC 20591  
Workphone 202/267-3560  
Workfax 202/267-5594  
E-mail edward.mcqueen@faa.dot.gov

**Carolyn Mercer**  
NASA Lewis Research Center  
21000 Brookpark Road  
MS 77-1  
Cleveland OH 44135  
Workphone 216/433-3411  
Workfax 216/433-8643  
E-mail carolyn.mercer@lerc.nasa.gov

**Richard Miake-Lye**  
Aerodyne Research, Inc.  
Center for Chem. & Env. Physics  
45 Manning Road  
Billerica MA 01821-3976  
Workphone 508/663-9500x251  
Workfax 508/663-4918  
E-mail

**Donald Minus**  
Wright Patterson AFB  
Fuels Branch, WL/POSF  
1790 Loop Road North  
Wright Patterson OH 45433-7103  
Workphone 937/255-7508  
Workfax 937/656-7176  
E-mail minusdk@wl.wpafb.af.mil

**Wilfredo Morales**  
NASA Lewis Research Center  
21000 Brookpark Road  
MS 23-3  
Cleveland OH 44135  
Workphone 216/433-6052  
Workfax 216/433-5170  
E-mail wilfredo.morales@lerc.nasa.gov

**Quang-Viet Nguyen**  
NASA Lewis Research Center  
21000 Brookpark Road  
MS 77-10  
Cleveland OH 44135  
Workphone 216/433-3574  
Workfax 216/433-3954  
E-mail qnguyen@lerc.nasa.gov

**Richard Niedzwiecki**  
NASA Lewis Research Center  
21000 Brookpark Road  
MS 77-10  
Cleveland OH 44135  
Workphone 216/433-3407  
Workfax 216/433-3954  
E-mail richard.niedzwiecki@lerc.nasa.gov

**Daniel Oh**  
Southwest Sciences, Inc.  
1570 Pacheco St., Suite E-11  
Santa Fe NM 87505  
Workphone 505/984-1322  
Workfax 505/988-9230  
E-mail sws@rt66.com

**Peter Pachthofer**  
NASA Lewis Research Center  
21000 Brookpark Road  
MS 6-9  
Cleveland OH 44135  
Workphone 216/433-5705  
Workfax 216/433-8551  
E-mail peter.m.pachthofer@lerc.nasa.gov

**Jonathan Paladino**  
University of Missouri-Rolla  
Cloud and Aerosol Sciences Laboratory  
G-7 Norwood Hall  
Rolla MO 65409-0430

Workphone 573/341-4338/4363  
Workfax 573/341-4891  
E-mail paladino@physics.umr.edu

**Andrea Paulson**  
Cleveland State University  
NASA LeRC Intern  
21000 Brookpark Road, MS 23-3  
Cleveland OH 44135

Workphone 216/433-6052  
Workfax 216/433-5170  
E-mail

**Paul Penko**  
NASA Lewis Research Center  
21000 Brookpark Road  
MS 77-10  
Cleveland OH 44135

Workphone 216/433-5356  
Workfax 216/433-3954  
E-mail penko@lerc.nasa.gov

**David Y.H. Pui**  
University of Minnesota  
Mechanical Engineering  
111 Church Street, S.E.  
Minneapolis MN 55455

Workphone 612/625-2537  
Workfax 612/625-6069  
E-mail dyhpui@maroon.tc.umn.edu

**Martin Rabinowitz**  
NASA Lewis Research Center  
21000 Brookpark Road  
MS 5-11  
Cleveland OH 44135

Workphone 216/433-5847  
Workfax  
E-mail martin.rabinowitz@lerc.nasa.gov

**Krish Radhakrishnan**  
NASA Lewis Research Center  
21000 Brookpark Road  
MS 77-10  
Cleveland OH 44135

Workphone 216/433-8483  
Workfax 216/433-3954  
E-mail fsradhak@lerc.nasa.gov

**W. Terry Rawlins**  
Physical Sciences, Inc.  
20 New England Business Center  
Andover MA 01810

Workphone 508/689-0003  
Workfax 508/689-3232  
E-mail rawlins@psicorp.com

**Juan Rivera**  
NASA Goddard Space Flight Center  
Code 916  
Greenbelt MD 20771-0001

Workphone 301/286-8602  
Workfax 301/286-1754  
E-mail rivera@polska.gsfc.nasa.gov

**Nader Rizk**  
Allison Engine Company  
Speed Code T14  
PO Box 420  
Indianapolis IN 46206-0420

Workphone 317/230-2629  
Workfax 317/230-3691  
E-mail ienkr@agt.gmeds.com

**John Rohde**  
NASA Lewis Research Center  
21000 Brookpark Road  
MS 11-3  
Cleveland OH 44135

Workphone 216/433-3949  
Workfax 216/433-5100  
E-mail j.rohde@lerc.nasa.gov

**Stanley Rubin**  
University of Cincinnati  
Department of Aerospace Engineering  
PO Box 210070  
Cincinnati OH 45221-0070

Workphone 513/556-3711  
Workfax 513/556-5038  
E-mail srubin@uceng.uc.edu

**Paul Sabla**  
GE Aircraft Engines  
One Neumann Way  
Cincinnati OH 45215

Workphone 513/552-2024  
Workfax 513/552-4147  
E-mail paul.e.sabla@ea.ge.com

**Terry Sanders**  
NASA Lewis Research Center  
21000 Brookpark Road  
MS 77-10  
Cleveland OH 44135  
Workphone 216/433-5849  
Workfax 216/433-3954  
E-mail terry.m.sanders@lerc.nasa.gov

**Irwin Segalman**  
Pratt & Whitney  
PO Box 109600  
MS 702-92  
West Palm Beach FL 33410-9600  
Workphone 561/796-3301  
Workfax 561/796-6242  
E-mail

**Jerry Seitzman**  
Georgia Institute of Technology  
School of Aerospace Engineering  
Atlanta GA 30332-0150  
Workphone 404/894-0013  
Workfax 404/894-2760  
E-mail jerry.seitzman@ae.gatech.edu

**Timothy Smith**  
NASA Lewis Research Center  
21000 Brookpark Road  
MS 60-4  
Cleveland OH 44135  
Workphone 216/977-7546  
Workfax 216/977-7545  
E-mail timothy.smith@lerc.nasa.gov

**Richard Strange**  
Pratt & Whitney  
400 Main Street, MS 121-02  
East Hartford CT 06118  
Workphone 860/565-5928  
Workfax 860/565-3086  
E-mail strangrr@pweh.com

**Ken Street**  
NASA Lewis Research Center  
21000 Brookpark Road  
MS 23-2  
Cleveland OH 44135  
Workphone 216/433-5032  
Workfax 216/433-5170  
E-mail ken.street@lerc.nasa.gov

**Don Sutkus**  
The Boeing Company  
MS 49-53  
PO Box 3707  
Seattle WA 98124  
Workphone 206/655-9484  
Workfax 206/655-4955  
E-mail donald.sutkus@pss.boeing.com

**Robert Tacina**  
NASA Lewis Research Center  
21000 Brookpark Road  
MS 77-10  
Cleveland OH 44135  
Workphone 216/433-3588  
Workfax 216/433-3954  
E-mail robert.tacina@lerc.nasa.gov

**Tom Ticich**  
Centenary College  
Chemistry Department  
400 Centenary Boulevard  
Shreveport LA 71134  
Workphone 318/869-5229  
Workfax 318/869-5026  
E-mail tticich@beta.centenary.edu

**Randy Van der Wal**  
NASA Lewis Research Center  
21000 Brookpark Road  
MS 110-3  
Cleveland OH 44135  
Workphone 216/433-9065  
Workfax 216-433-3793  
E-mail randy@rvander.lerc.nasa.gov

**Thomas VanOverbeke**  
NASA Lewis Research Center  
21000 Brookpark Road  
MS 5-11  
Cleveland OH 44135  
Workphone 216/433-5867  
Workfax 216/433-5802  
E-mail aevano@thesis.lerc.nasa.gov

**Michael Vermeersch**  
GE Aircraft Engines  
One Neumann Way  
Cincinnati OH 45215  
Workphone 513/243-3872  
Workfax  
E-mail michael.vermeersch@ae.ge.com

**Albert Viggiano**  
Phillips Laboratory (GPSC)  
29 Randolph Road  
Hanscom AFB MA 01731-3010

Workphone 617/377-4028  
Workfax 617/377-1148  
E-mail viggiano@plh.af.mil

**Illari Vihinen**  
US Air Force/Wright Lab  
Building 490  
1790 Loop Road North  
Wright Patterson OH 45433-7103

Workphone 937/255-8623  
Workfax 937/255-1125  
E-mail vihineni@ward.appl.wpafb.af.mil

**Ian Waitz**  
Massachusetts Institute of Technology  
Gas Turbine Laboratory, 31-266  
77 Massachusetts Avenue  
Cambridge MA 02139

Workphone 617/253-0218  
Workfax 617/258-6093  
E-mail iaw@mit.edu

**Chowen Wey**  
NASA Lewis Research Center  
21000 Brookpark Road  
MS 77-10  
Cleveland OH 44135

Workphone 216/433-8357  
Workfax 216/433-3954  
E-mail chowen.c.vey@lerc.nasa.gov

**Changlie Wey**  
NYMA, Inc.  
2001 Aerospace Parkway  
Brook Park OH 44142

Workphone 216/433-5379  
Workfax 216/433-3954  
E-mail changlie.vey@lerc.nasa.gov

**Philip Whitefield**  
University of Missouri-Rolla  
Cloud and Aerosol Sciences Laboratory  
G-7 Norwood Hall  
Rolla MO 65409-0430

Workphone 573/341-4340  
Workfax 573/341-4891  
E-mail pwhite@physics.UMR.edu

**Michael Winter**  
United Technologies Research Center  
411 Silver Lane  
East Hartford CT 06108

Workphone 860/610-7805  
Workfax 860/610-7911  
E-mail winterm@utrc.utc.com

**Sheng-Tao Yu**  
NYMA, Inc.  
2001 Aerospace Parkway  
MS NYMA  
Brook Park OH 44142

Workphone 216/433-2607  
Workfax  
E-mail styu@flame.lerc.nasa.gov

**Martin Zabielski**  
United Technologies Research Center  
411 Silver Lane  
East Hartford CT 06108

Workphone 860/610-7431  
Workfax 860/610-2151  
E-mail zabielfm@utrc.utc.com

**Michelle Zaller**  
NASA Lewis Research Center  
21000 Brookpark Road  
MS 77-1  
Cleveland OH 44135

Workphone 216/433-5992  
Workfax  
E-mail mzaller@lerc.nasa.gov

**Joe Zelina**  
AlliedSignal Engines  
PO Box 52181  
111 S. 34th Street  
Phoenix AZ 85072-2181

Workphone 602/231-4576  
Workfax 602/231-1055  
E-mail joe.zelina@alliedsignal.com

**Mary Zeller**  
NASA Lewis Research Center  
21000 Brookpark Road  
MS 23-2  
Cleveland OH 44135

Workphone 216/433-2061  
Workfax 216/433-5170  
E-mail mary.zeller@lerc.nasa.gov

10/10/10

# REPORT DOCUMENTATION PAGE

Public reporting burden for this collection of information is estimated to average 1 hour per response, including the time for review, gathering and maintaining the data needed, and completing and reviewing the collection of information. Send comments regarding collection of information, including suggestions for reducing this burden, to Washington Headquarters Services, Directorate for Information Operations and Reports, 1215 Jefferson Davis Highway, Suite 1204, Arlington, VA 22202-4302, and to the Office of Management and Budget, Paperwork Reduction Project (0704-0188).

<b>1. AGENCY USE ONLY (Leave blank)</b>		<b>2. REPORT DATE</b> June 1999	<b>3. REPORT TYPE AND DATES COVERED</b> Continuation	
<b>4. TITLE AND SUBTITLE</b>  Workshop on Aerosols and Particulates From Aircraft Gas Turbine Engines			<b>5.</b>	
<b>6. AUTHOR(S)</b>				
<b>7. PERFORMING ORGANIZATION NAME(S) AND ADDRESS(ES)</b>  National Aeronautics and Space Administration John H. Glenn Research Center at Lewis Field Cleveland, Ohio 44135-3191			<b>8. PERFORMING ORGANIZATION REPORT NUMBER</b>  E-11676	
<b>9. SPONSORING/MONITORING AGENCY NAME(S) AND ADDRESS(ES)</b>  National Aeronautics and Space Administration Washington, DC 20546-0001			<b>10. SPONSORING/MONITORING AGENCY REPORT NUMBER</b>  NASA CP-1999-208918	
<b>11. SUPPLEMENTARY NOTES</b>  Compiled by Chowen Chou Wey, organization code 0300, (216) 433-8357.				
<b>12a. DISTRIBUTION/AVAILABILITY STATEMENT</b>  Unclassified - Unlimited Subject Categories: 01, 02, 09, 35, and 45  This publication is available from the NASA Center for Aerospace Information, (301) 621-0390.			<b>12b. DISTRIBUTION CODE</b>  Distribution: Nonstandard	
<b>13. ABSTRACT (Maximum 200 words)</b>  In response to the National Research Council (NRC) recommendations, the Workshop on Aerosols and Particulates from Aircraft Gas Turbine Engines was organized by the NASA Lewis Research Center and held on July 29-30, 1997 at the Ohio Aerospace Institute in Cleveland, Ohio. The objective is to develop consensus among experts in the field of aerosols from gas turbine combustors and engines as to important issues and venues to be considered. Workshop participants' expertise included engine and aircraft design, combustion processes and kinetics, atmospheric science, fuels, and flight operations and instrumentation.				
<b>14. SUBJECT TERMS</b>  Emissions; Particulate; Aerosol; Aircraft; Engine; Atmosphere			<b>15. NUMBER OF PAGES</b> 252	
			<b>16. PRICE CODE</b> A12	
<b>17. SECURITY CLASSIFICATION OF REPORT</b> Unclassified	<b>18. SECURITY CLASSIFICATION OF THIS PAGE</b> Unclassified	<b>19. SECURITY CLASSIFICATION OF ABSTRACT</b> Unclassified	<b>20. LIMITATION OF ABSTRACT</b>	