

NASA/CR-2000-210327

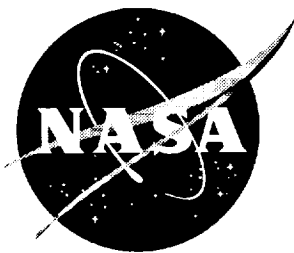

2000 NASA-HU American Society for Engineering Education (ASEE) Summer Faculty Fellowship Program

Compiled by:

*William P. Marable
Hampton University, Hampton, Virginia*

*Deborah B. Murray
Old Dominion University, Norfolk, Virginia*

September 2000

The NASA STI Program Office ... in Profile

Since its founding, NASA has been dedicated to the advancement of aeronautics and space science. The NASA Scientific and Technical Information (STI) Program Office plays a key part in helping NASA maintain this important role.

The NASA STI Program Office is operated by Langley Research Center, the lead center for NASA's scientific and technical information. The NASA STI Program Office provides access to the NASA STI Database, the largest collection of aeronautical and space science STI in the world. The Program Office is also NASA's institutional mechanism for disseminating the results of its research and development activities. These results are published by NASA in the NASA STI Report Series, which includes the following report types:

- **TECHNICAL PUBLICATION.** Reports of completed research or a major significant phase of research that present the results of NASA programs and include extensive data or theoretical analysis. Includes compilations of significant scientific and technical data and information deemed to be of continuing reference value. NASA's counterpart of peer reviewed formal professional papers, but having less stringent limitations on manuscript length and extent of graphic presentations.
- **TECHNICAL MEMORANDUM.** Scientific and technical findings that are preliminary or of specialized interest, e.g., quick release reports, working papers, and bibliographies that contain minimal annotation. Does not contain extensive analysis.
- **CONTRACTOR REPORT.** Scientific and technical findings by NASA-sponsored contractors and grantees.

- **CONFERENCE PUBLICATION.** Collected papers from scientific and technical conferences, symposia, seminars, or other meetings sponsored or cosponsored by NASA.
- **SPECIAL PUBLICATION.** Scientific, technical, or historical information from NASA programs, projects, and missions, often concerned with subjects having substantial public interest.
- **TECHNICAL TRANSLATION.** English-language translations of foreign scientific and technical material pertinent to NASA's mission.

Specialized services that complement the STI Program Office's diverse offerings include creating custom thesauri, building customized data bases, organizing and publishing research results ... even providing videos.

For more information about the NASA STI Program Office, see the following:

- Access the NASA STI Program Home Page at <http://www.sti.nasa.gov>
- E-mail your question via the Internet to help@sti.nasa.gov
- Fax your question to the NASA STI Help Desk at (301) 621-0134
- Telephone the NASA STI Help Desk at (301) 621-0390
- Write to:
NASA STI Help Desk
NASA Center for AeroSpace Information
7121 Standard Drive
Hanover, MD 21076-1320

NASA/CR-2000-210327

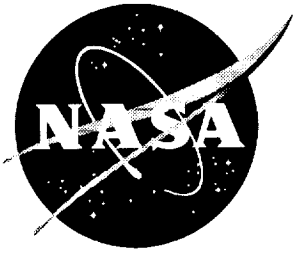

2000 NASA-HU American Society for Engineering Education (ASEE) Summer Faculty Fellowship Program

Compiled by:

*William P. Marable
Hampton University, Hampton, Virginia*

*Deborah B. Murray
Old Dominion University, Norfolk, Virginia*

National Aeronautics and
Space Administration

Langley Research Center
Hampton, Virginia 23681-2199

Prepared for Langley Research Center
under Cooperative Agreement NCC-1-358

September 2000

Available from the following:

NASA Center for AeroSpace Information (CAST)
7121 Standard Drive
Hanover, MD 21076-1320
(301) 621-0390

National Technical Information Service (NTIS)
5285 Port Royal Road
Springfield, VA 22161-2171
(703) 487-4650

TABLE OF CONTENTS

		<u>Page</u>
Section I	Organization and Management	1
Section II	Recruitment and Selection of Fellows	3
	Returning Fellows	3
	First Year Fellows	3
Section III	Stipend and Travel	6
Section IV	2000 ASEE SFFP Activities	6
	Lecture Series	6
	Interaction Opportunity/Picnic	6
	Proposal Seminar	7
	Seminar/Banquet	7
	ASEE Activities Committee	7
Section V	Research Participation	8
	Fellows by Competency/Program Office	8
	Fellows by Degree Area	8
	Extensions	9
	Attendance at Short Courses, Seminars, and Conferences	9
	Papers Presented	11
	Anticipated Research Proposals	13
	Funded Research Proposals	14
Section VI	Summary of Program Evaluation	16
	Fellows' Comments and Recommendations	22
	Summary of Associates' Evaluation	24
	Research Associates' Comments	25
	Research Associates' Recommendations	25
Section VII	Co-Director's Recommendations	26
Appendix I	2000 Participants	27
Appendix II	Summer Lecture Series - Presentations by Research	
	Fellows - Calendar of Activities - Summer Lecture Series	30
	Summer Lecture Series Program Sample	32
	Presentations by Research Fellows	34
	Calendar of Activities	35

		<u>Page</u>
Appendix III	Group Picture of Research Fellows	36
	List of Attendees	37
Appendix IV	Distribution of Fellows by University Rank and Distribution of Fellows by Competency/Program Office	38
Appendix V	Distribution of Fellows Ethnicity/Female and Distribution of Fellows Ethnicity/Male	40
Appendix VI	Distribution of Fellows by University	42
Appendix VII	Abstracts - Research Fellows	43
Appendix VIII	Program Orientation Evaluation Report	84
Appendix IX	Policies, Practices, and Procedures Manual	85

LIST OF TABLES

<u>Table No.</u>		<u>Page</u>
1	Distribution by Year in Program	4
2	Distribution by University	4
3	Distribution by Selection	5
4	Distribution by Funding	5

LIST OF ABSTRACTS - RESEARCH FELLOWS
(Appendix VII)

	<u>Page</u>
“Oxidative-Resistive Coatings on Carbon-Carbon Composites for Aerospace Applications,” by Dr. Tarek Abdel-Fattah, Christopher Newport University	44
“Accelerated Testing of Polymeric Composites: Correlation of Scale-up Effects on Viscoelastic Behavior,” by Dr. Beckry Abdel-Magid, Winona State University	45
““The DEVELOP Center - Summer 2000 ASEE Program at NASA LaRC,” by Prof. Janice D. Cawthorn, Hampton University	46
“Density and Mach Number Effects on Piezoelectric Flow Control Actuator Performance,” by Dr. Frank W. Chambers, Oklahoma State University	47
“A Computational Investigation of Approximation Techniques for Engineering Design Optimization,” by Dr. William A. Crossley, Purdue University	48
“Higher-Order Methods for the Solution of the Poisson Equation in Parallel,” by Dr. Ayodeji O. Demuren, Old Dominion University	49
“High Power Rocket Demonstrator of a Reusable Glideback Booster,” by Dr. Dianne DeTurris, California Polytechnic State University	50
“A Universal Model for Predicting Gaseous and Particulate Emissions from Biomass Burning,” by Dr. George S. Devendorf, Middle Tennessee State University	51
“Investigation of an Eye-Safe Lidar For Carbon-Dioxide Measurements,” by Dr. Amin N. Dharamsi, Old Dominion University	52
“A Real-world Scenario-based Learning Framework for Distributed Collaborative Engineering,” by Dr. David A. Dryer, Old Dominion University	53
“Hamiltonian Formulations and Conservation Laws for Fluid Flow,” by Dr. Mark Farris, Midwestern State University	54
“Aerodynamic Evaluation of Tip Mounted Jet Nacelles,” by Dr. Thomas A. Gally, Embry-Riddle Aeronautical University	55

LIST OF ABSTRACTS - RESEARCH FELLOWS - Continued

	<u>Page</u>
“Utilizing NASA Computer Technology to Solve Large-Scale Problems for the U. S. Auto Industry,” by Dr. Myron Ginsberg, University of Michigan	56
“Velocity Filtered Density Function for Large Eddy Simulation of Turbulent Flows,” by Dr. Peyman Givi, State University of New York-Buffalo	57
“Patch Network for Power Allocation and Distribution in Smart Materials,” by Dr. Walter T. Golembiewski, Norfolk State University	58
“Some Signal Processing Challenges in the Geostationary Imaging Fourier Transform Spectrometer,” by Dr. Monson H. Hayes, Georgia Institute of Technology	59
Abstract not available for Dr. Jagannathan V. Iyengar, University of Nebraska-Kearney	60
“Geographic Information Systems (GIS) Used to Manage an Online Facilities Master Plan Portfolio at NASA Langley Research Center,” by Prof. Christopher B. Kerns, Crownpoint Institute of Technology	61
“Compressible Boundary Layer Receptivity of a Swept Wing Due to Surface Roughness Using Parabolized Stability Equations (PSE),” by Dr. Frank P. Kozusko, Hampton University	62
“General Aviation Simulator (GAS) Baseline Study for Advanced Weather Information Display Program,” by Dr. Mark D. Lee, Old Dominion University	63
“A Risk-Based Method for Evaluating NASA Technology for the National Airspace System,” by Dr. Garrick E. Louis, University of Virginia	64
“Single Frequency Er:Yb Co-doped Fiber Optic Laser for Fiber Sensor Applications,” by Dr. Patricia F. Mead, University of Maryland	65
“NASA and A Second-Generation Supersonic Transport,” by Dr. Anne Millbrooke, Northwest Campus, University of Alaska Fairbanks	66
“Optical and Thermal Radiative Analysis of the CERES Instrument Using Monte-Carlo Ray-Trace Method,” by Prof. Felix J. Nevarez, Polytechnic University of Puerto Rico	67

LIST OF ABSTRACTS - RESEARCH FELLOWS - Continued

	<u>Page</u>
“Efficient Sparse Assembling/Equation-Eigen Solvers for Finite Element Acoustics/ CFD/Structures/Electromagnetics Engineering Applications,” by Dr. Duc T. Nguyen, Old Dominion University	68
“NASA Live: Using Videoconferencing as the Basis of a New Program in Distance Learning for the Langley Research Center Office of Education,” by Prof. William Nichols, Blackfeet Community College	69
“Conductive Ceramic Coatings on Silica,” by Dr. Ronald J. Pollock, Pennsylvania State University	70
“Elastic Tailoring of Aircraft Structures with Composites,” by Dr. Lawrence W. Rehfield, University of California-Davis	71
“Finite Element Modeling of Synthetic Jet Actuators,” by Dr. Jeng-Jong Ro, Old Dominion University	72
“Observations on NASA Sponsored Programs for In-Service and Pre-Service Teachers,” by Dr. George T. Rublein, College of William and Mary	73
“Active Control of Vibration without Computers,” by Dr. M. Roman Serbyn, Morgan State University	74
“2000 NASA-ASEE Summer Faculty Fellowship Program Project Report,” by Prof. Mir S. Shirvani, New River Community College	75
“Aerodynamic Uncertainty Studies,” by Dr. Arthur C. Taylor, III, Old Dominion University	76
“Reports From Kitty Hawk: The Wright Brothers on the Outer Banks of North Carolina,” by Dr. Larry E. Tise, First Flight Centennial Commission/East Carolina University	77
“An Analysis of the Performance of the Diode Laser Hygrometer During the Solve Mission,” by Dr. George F. Tucker, The Sage Colleges	78

LIST OF ABSTRACTS - RESEARCH FELLOWS - Continued

	<u>Page</u>
“Development of a Real Time Display for Noise Reduction Program,” by Dr. Jerry H. Tucker, Virginia Commonwealth University	79
“Development of Training Modules and Its Effective Online/Offline Delivery Using Latest Technology,” by Dr. Arun K. Verma, Hampton University	80
“The Application of Prismatic Elements for the Solution of Electromagnetic Eigenvalue Problems,” by Dr. Gregory M. Wilkins, Morgan State University	81
“Analysis of Friction Stir Welded Lap Joints in Thin Sheet Aluminum Alloys,” by Dr. Keith M. Williamson, Old Dominion University	82
“User-Tracking Software for Gathering Detailed Web Site Statistics in a Restrictive Environment,” by Dr. James P. Withington, Inter American University of Puerto Rico .	83

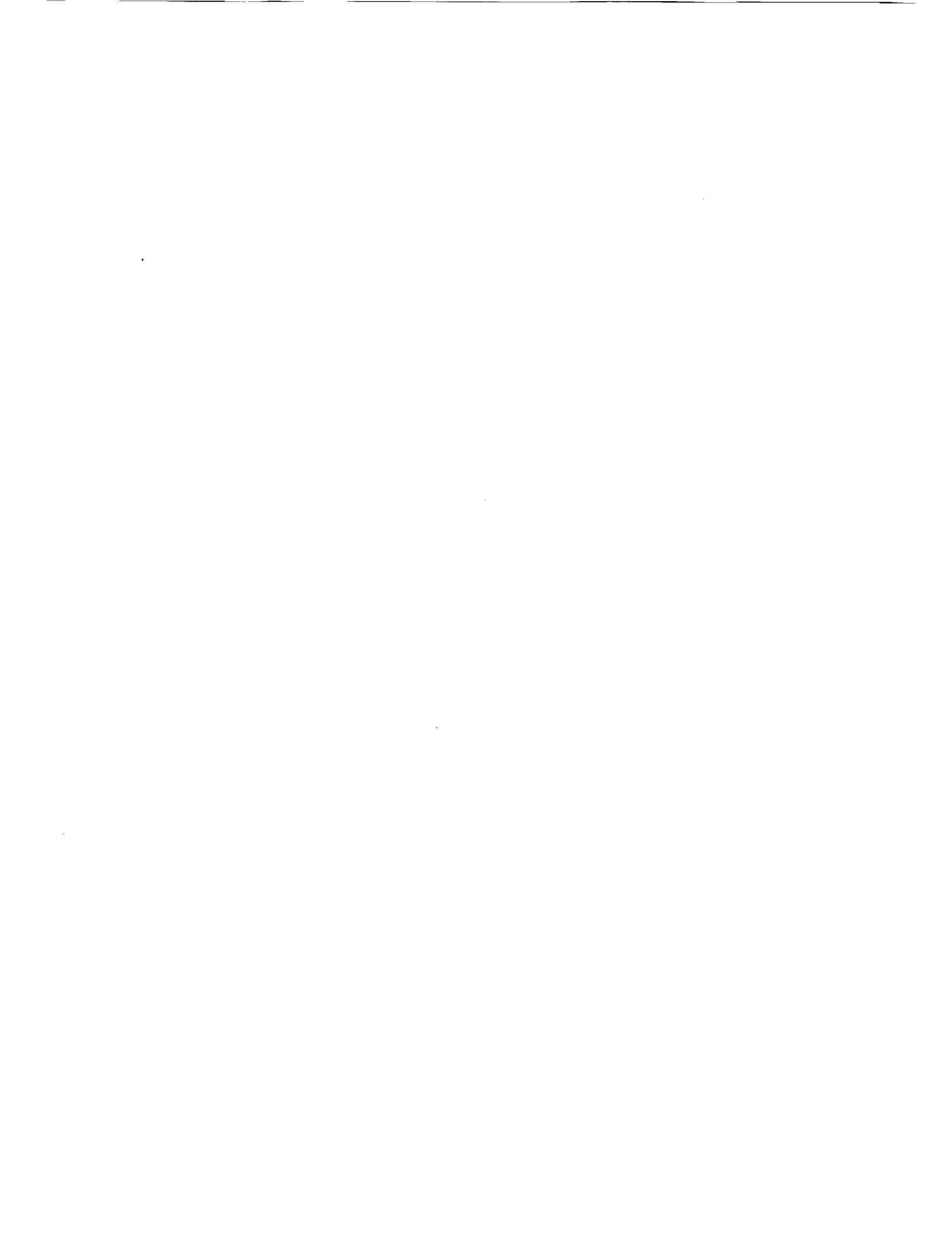

SECTION 1

ORGANIZATION AND MANAGEMENT

The 2000 Hampton University (HU)-NASA Langley Research Center (LaRC) Summer Faculty Fellowship Research Program, the thirty-sixth such institute to be held at LaRC, was planned by a committee consisting of the University Co-Director, LaRC Staff Assistants (SAs) from the research Competencies, and the Office of Education.

An initial assessment of each applicant's credentials was made by the University Co-Director and the NASA LaRC University Affairs Officer. The purpose of this assessment was to ascertain to which Competency the applicant's credentials should be circulated for review. Once this determination was made, an application distribution meeting was scheduled with the SAs where applications were distributed and instructions concerning the selection process were discussed. At a later date, the SAs notified the ASEE office of the selections made within their Group.

The Program Manager/Administrative Assistant then contacted each selected Fellow by phone extending the individual a verbal appointment, which was followed up with a formal letter of confirmation. Individuals were given ten days to respond in writing to the appointment. Once the letters of acceptance were received, a roster was sent to each SA advising them of their Fellows for the summer program.

Fellows accepting the appointment were provided with material relevant to housing, travel, payroll distribution, and the orientation. Each Fellow, in advance of commencing the program, was contacted by his or her Research Associate or representative of the branch.

Each Fellow and Research Associate received a 2000 ASEE Policies, Practices, and Procedures Manual that clarified many commonly asked questions up front regarding the roles, responsibilities, policies, and procedures of both parties. This manual was very beneficial and will be updated annually to be used in the years to come (Appendix IX).

At the Orientation meeting, Dr. Samuel E. Massenberg, Director, Langley Office of Education, welcomed the summer program participants to LaRC. Mr. Edwin J. Prior, Deputy Director, Langley Office of Education, presented an overview of Langley Research Center. Introductions of the Administrative Staff and a program overview was presented by Mr. Roger A. Hathaway, University Affairs Officer. A Health Briefing was provided by Dr. Leroy P. Gross. Mr. James R. Hall provided a security briefing followed by a presentation on Export Control and Information Protection provided by Mr. Stuart Pendleton who was standing in for Mr. Joseph J. Mathis, Jr., LaRC's Center Export Administrator. An Information Technology Security Briefing

was given by Mr. Geoffrey M. Tennille, Information Technology Security Manager for LaRC. Following a short break, a program breakout session was next on the agenda, enabling the ASEE administrative staff (Dr. William P. Marable-ASEE Co-Director, and Mrs. Debbie Murray-ASEE Program Manager/Administrative Assistant) to meet with the 2000 Fellows to discuss administrative procedures and answer questions. Following the breakout session, the Fellows were greeted by their LaRC Associates who then escorted them to their respective work sites. An evaluation of the orientation meeting was completed (Appendix VIII).

Throughout the program, the University Co-Director served as the principal liaison person and had frequent contacts with the Fellows. The University Co-Director also served as the principal administrative officer. At the conclusion of the program, each Fellow submitted an abstract describing his/her accomplishments (Appendix VII). Each Fellow gave a talk on his/her research within the Division. The Competency SAs then forwarded to the Co-Director the names of the Fellows recommended within their Competencies for the Final Presentations. Seven excellent papers were presented to the Fellows, Research Associates, and invited guests. For the sixth year, the presentations were judged by a panel of LaRC researchers for "The Best Research Presentation" competition (Appendix II). The Final Presentations were concluded with a luncheon at the Langley Air Force Base Officer's Club where the winners were announced and presented with a certificate and invitation to return to LaRC for a visit during the academic year.

Each Fellow and Research Associate was asked to complete a questionnaire provided for the purpose of evaluating the summer program (Section VI).

SECTION II

RECRUITMENT AND SELECTION OF FELLOWS

Returning Fellows

An invitation to apply and possibly participate in the Old Dominion University (ODU)-NASA Langley Research Center (LaRC) Program was extended to the individuals who held 1999 fellowship appointments and were eligible to participate for a second year. Out of the individuals responding to the invitation, ten accepted offers of appointment (Table 1). Seven Fellows from previous years accepted offers of appointment.

First Year Fellows

For the 2000 program, ASEE Headquarters once again provided a web site for the summer program application materials in lieu of brochures being mailed out. Many personal contacts to deans and department heads of various engineering schools in the East, South, and Midwest, were made by Dr. William P. Marable of Hampton University (HU) and Dr. Surendra N. Tiwari of Old Dominion University (ODU) requesting their assistance in bringing to the attention of their faculties the HU-ODU-NASA LaRC program. In addition to the above, a number of departments of chemistry, physics, computer science, and mathematics at colleges (including community colleges and minority institutions) and universities in the state of Virginia, as well as, neighboring states were contacted regarding this program (Table 2). Additional recruiting efforts included either attendance at or providing information for several of the minority and majority conferences, as well as, Video Teleconferences hosted by this staff. These efforts resulted in a total of sixty-six formal applications indicating the HU-ODU-NASA LaRC program as their first choice, and a total of thirteen applications indicating the aforementioned as their second choice. The total number of applications received came to seventy-nine (Table 3).

Forty applicants formally accepted the invitation to participate in the program. Eleven applicants declined the invitation. A few Fellows delayed their response while waiting for other possible offers from other programs. The top researchers tend to apply to more than one program, and will make their selection based on research interest and stipend. Thirteen positions were initially budgeted by NASA Headquarters. Twenty-six positions were funded by the LaRC Competencies (Table 4) and three Fellows were split-funded sharing both Headquarters and LaRC funding.

The average age of the participants was once again 46.

Table 1 - Distribution of 2000 ASEE Fellows by Year in Program

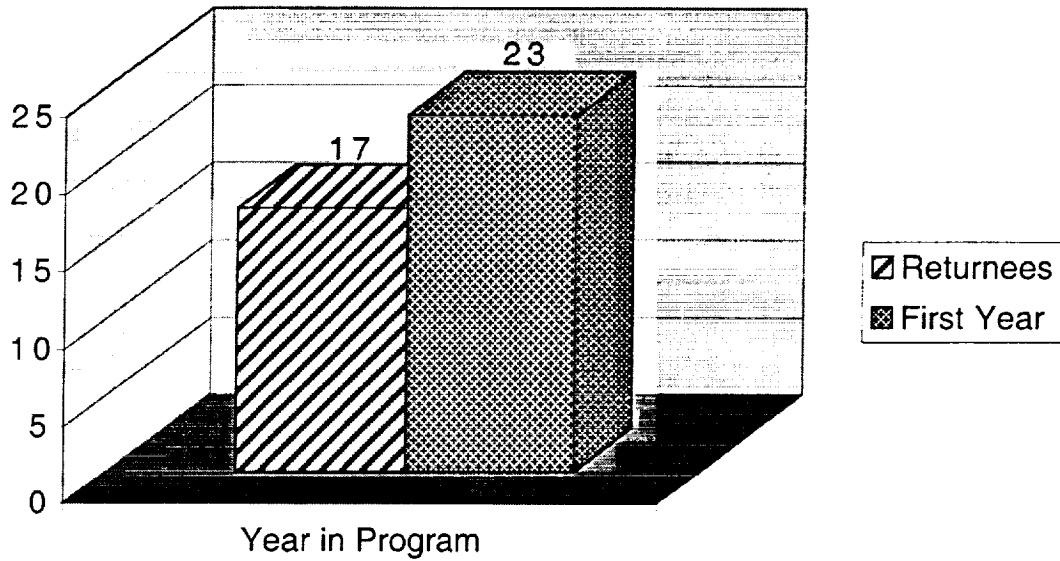

Table 2 - Distribution of 2000 ASEE Fellows by University

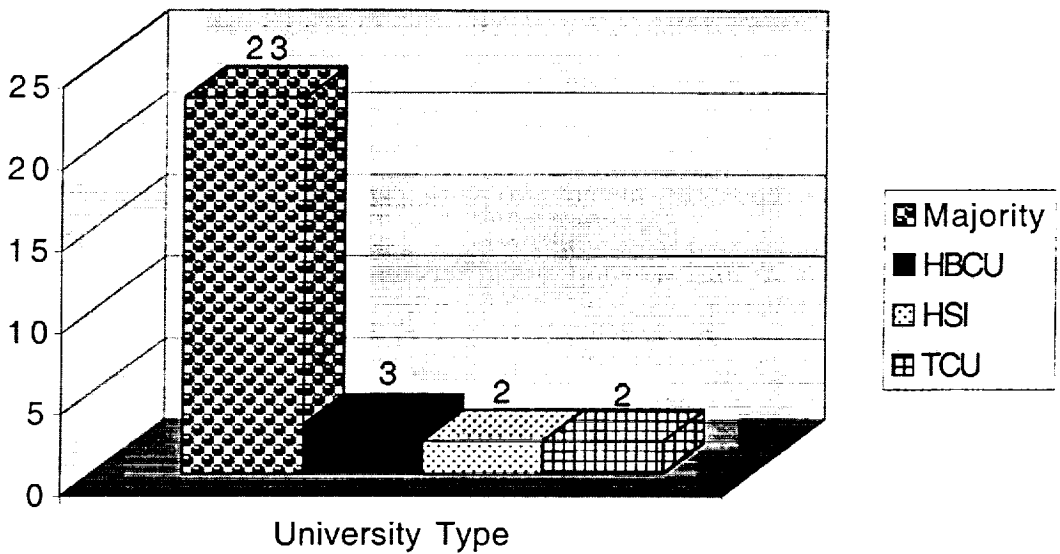

Table 3 - Distribution of 2000 ASEE Fellows by Selection

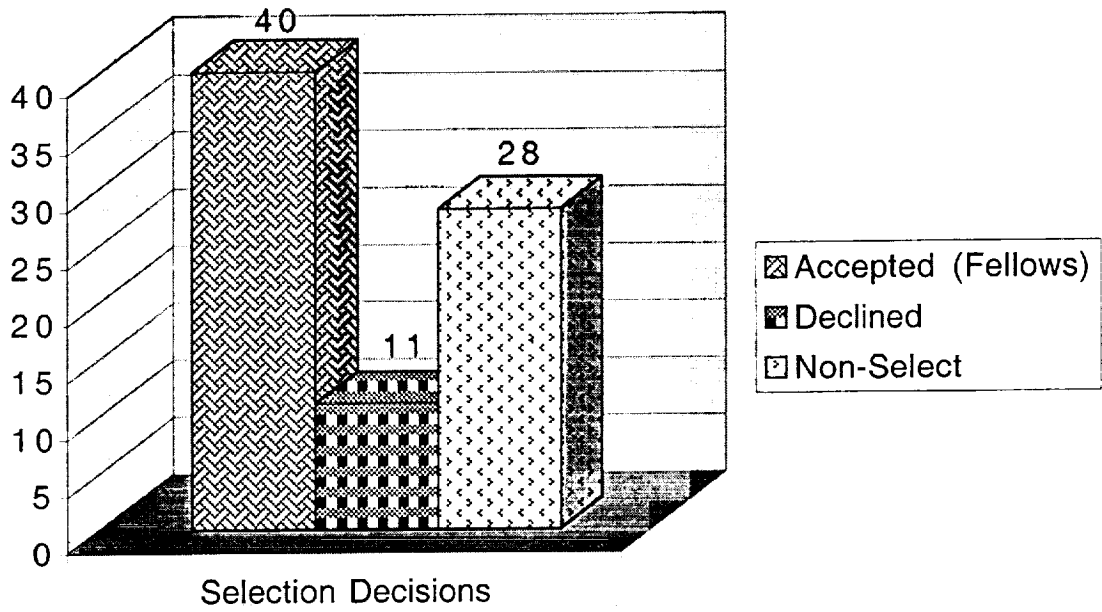
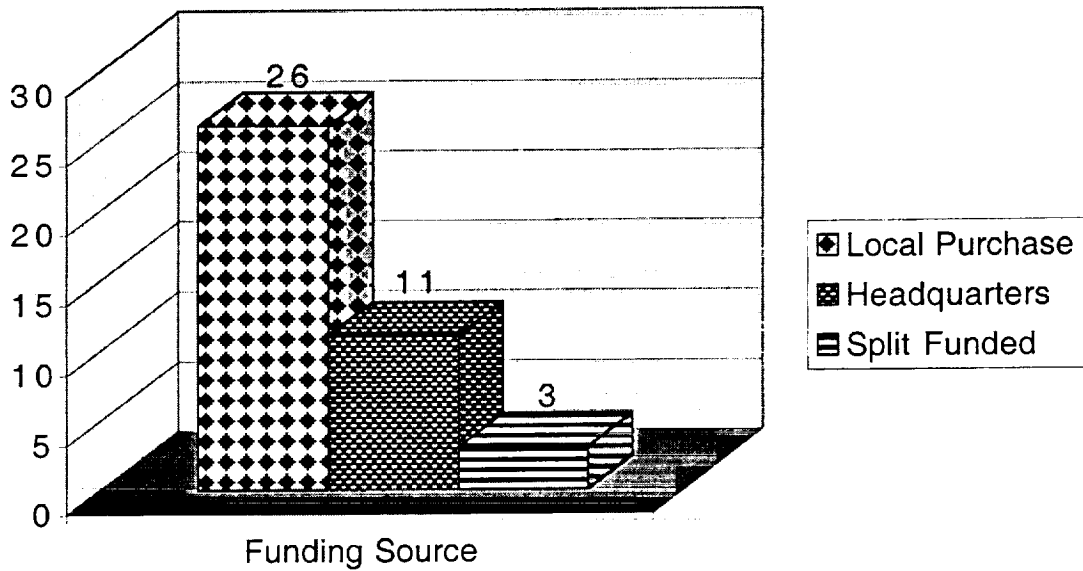

Table 4 - Distribution of 2000 ASEE Fellows by Funding



SECTION III

STIPEND AND TRAVEL

A ten-week stipend of \$10,000.00 was awarded to each Fellow. Thirty-eight percent of the Fellows indicated that the stipend was not the primary motivator in their participating in the ASEE program. This continues to suggest that the importance of the stipend amount is quite significant based on the fifty-seven percent that indicated at least in part it was a primary motivator. Five percent did not answer. Only fifteen percent deemed the current stipend as adequate, the greater majority of the faculty, eighty-five percent, suggested an increase was in order, or a cost of living should be included (Survey-Section VI). This stipend continues to fall short of matching what most professors could have earned based on academic salaries or participating in other fellowships. The decision to participate in the summer faculty research program continues to reflect the willingness of the Fellow to make some financial sacrifice in order to have the experience of working with NASA's finest scientists and researchers.

Mileage or air fare expenses incurred by the Fellows from their institution to Hampton, Virginia, as well as their return trip, were reimbursed in accordance with current HU regulations. A relocation allowance of \$1,000 was provided for the Fellows at a distance of 50 miles or more who were required to relocate.

SECTION IV

2000 ASEE SFFP ACTIVITIES

Lecture Series

The Lecture Series this summer was successful and well received. There was a total of five lectures presented. The lectures were given by distinguished NASA scientists and researchers. Some of the topics included "A Brief History of Fire on Earth," presented by LaRC's Dr. Joel S. Levine, "Experiences and Challenges in Mars Exploration," presented by LaRC's Dr. Robert D. Braun, and "Emerging Materials Technologies for Aerospace Applications," joint presentation by Drs. Joycelyn S. Harrison and Mia Siochi (Appendix II).

Interaction Opportunity/Picnic

The annual Office of Education Interaction Opportunity/Picnic was held on Wednesday, June 12, 2000, for the summer program participants, their families, NASA Associates, and invited guests. This allowed for informal interaction between the Fellows, as well as, with the administrative staff. The participants were also provided with T-shirts bearing the 2000 ASEE design.

Proposal Seminar

A Proposal Seminar was held for the Fellows on Wednesday, August 2, 2000. Mr. Edwin J. Prior, Deputy Director, Office of Education, presented an overview of the proper procedures to adhere to in submitting an unsolicited proposal to NASA. The program covered both the NASA and university perspectives. Mr. Fred Morrell gave a presentation on the Small Business Innovative Research program with emphasis on STTR "Small Business Technical Transfer Pilot Program." Dr. William A. Crossley, returning ASEE Fellow, shared his experience with successfully obtaining a NASA funded grant. There was also a panel question and answer session. The panel members included Langley researchers who frequently review proposals that are submitted, and in the audience were representatives from the grants and contracting offices who also responded to questions in their field. This aspect of the proposal seminar was very well received. They received packages with information including the most current Research Grant Handbook information and web site locations.

Seminar/Banquet

On Friday, July 30, 1999, a seminar/banquet was held for the Fellows and their spouses. The banquet took place at the beautiful Langley Air Force Base Officer's Club. ASEE end of the program information, certificates, and group pictures were presented to each Fellow at the banquet. Remarks were presented by Dr. Samuel E. Massenberg, Director, Office of Education.

ASEE Activities Committee

As in the past, an ASEE Activities Committee was formed to plan social outings for the program participants and their families. A weekly dinner was planned for those who desired to participate. Tours of Center facilities including a wind tunnel, simulator, and Langley Air Force Base were scheduled. This was very well received by the Fellows. The Office of Education also sponsored a Moonlight Cruise and a Dinner Cruise aboard the beautiful Spirit of Norfolk for the Fellows and their spouses. (Appendix II).

SECTION V

RESEARCH PARTICIPATION

The HU-LaRC Summer Research Program, as in past years, placed the greatest emphasis on research aspects of the program. Included in this report are abstracts from the Fellows showing their accomplishments during the summer. These abstracts, together with the comments of the LaRC Research Associates with whom the Fellows worked very closely, provide convincing evidence of the continued success of this part of the program. The Fellows' comments during the evaluation of the program indicated their satisfaction with their research projects, as well as, with the facilities available to them.

The research projects undertaken by the Fellows were greatly diversified as is reflected in their summer research assignments. Their assignments were as follows:

Number of Fellows Assigned	Competency/Program Office
11	Aerodynamics, Aerothermodynamics, and Acoustics Competency
6	Aerospace Systems, Concepts, and Analysis Competency
3	Airborne Systems Competency
2	Atmospheric Sciences Competency
4	Business Management
1	Earth & Space Science Program Office
1	Intelligent Synthesis Environment Program Office
6	Structures and Materials Competency
6	Systems Engineering Competency

Thirty-six (90%) of the participants were holders of the doctorate degree. Three (7%) held masters degrees and one (3%) held bachelor's degrees. The group was again highly diversified with respect to background. Following are the areas in which the last degree was earned (twenty-three different disciplines):

Number	Area of Degree
1	Aeronautics and Astronautics
3	Chemistry
1	Computer Science
1	Decision Sciences

Continued:

Number	Area of Degree
3	Education (including 1 Higher Education Admin. and 1 Education Admin, and Supervision)
23	Engineering (including 4 Aerospace; 1 Civil and Structural; 1 Computer and Electrical; and 6 Electrical; 1 Engineering Psychology; 1 Engineering and Public Policy; 1 Industrial; 7 Mechanical; 1 Structural)
1	History
1	History and Sociology Science
4	Mathematics (including 1 Applied Mathematics)
2	Physics (including 1 Applied)
1	Physiology

Extensions

Per special written request by the LaRC Associate and the approval of the ASEE Co-Director, the following individual was granted an extension of tenure:

Prof. Janice D. Cawthorn
Dr. Myron Ginsberg
Dr. Ronald J. Pollock
Dr. M. Roman Serbyn
Dr. Jerry H. Tucker
Dr. Arun K. Verma

Attendance at Short Courses, Seminars, and Conferences

During the course of the summer, Fellows have the opportunity to attend regularly scheduled Langley Research Center seminars and meetings, to include but not limited to ASEE Technical Lectures, Institute for Computer Applications in Science and Engineering (ICASE) seminars, World Wide Web and Internet training courses, computer training, as well as short courses or meetings within their Competency. In addition, there were a number of short courses, seminars, and conferences, in which the subject matter had relevance to the Fellows' research projects. A number of Fellows requested approval to attend one or more of these conferences as it was their

considered opinion that the knowledge gained by their attendance would be of value to their research projects. Those Fellows who did attend had the approval of both the Research Associate and the University Co-Director.

Short Courses, Seminars, and Conferences Attended

Beckry M. Abdel-Magid: Nano Materials and Nano-Technology Conference at LaRC; 2000 Small Disadvantaged Business/University Opportunities Forum, July, 2000; Crew Systems Research Seminar; Composite Materials for Aerospace Applications Seminar; Carbon Fiber Composites for Cryogenic Tanks short course.

Thomas A. Gally: "Aircraft Structures Analysis and Design" short course through the University of Kansas.

Walter T. Golembiewski: Nano-Biotechnology Conference, June 14-15, 2000; 2000 Small Disadvantaged Business/University Opportunities Forum, July, 2000.

Christopher B. Kerns: 2000 Small Disadvantaged Business/University Opportunities Forum, July, 2000.

Mark D. Lee: Human Factors and Ergonomics Society Conference.

Ronald J. Pollock: Nano-Biotechnology Conference, June 14-15, 2000; Two additional lectures on Nanotubes at the Advanced Materials & Processing Branch, LaRC.

George T. Rublein: VCEPT Collaborative Conference, Farmville, VA.

M. Roman Serbyn: Visit to Oceana Sensor Technologies, Inc., Virginia Beach, VA.

George F. Tucker: The Astronomical Society of the Pacific Annual Meeting - ASTROCON, 2000.

Jerry H. Tucker: Introduction to VHDL.

Arun K. Verma: Technology 2000: Looking to the Future, Williamsburg, VA, July 26-28, 2000.

Keith M. Williamson: Flemings Symposium, MIT, Cambridge, MA.

Papers Presented or Anticipated

*Indicates Anticipated Papers

Beckry M. Abdel-Magid: "Accelerated Testing of Polymeric Composites: Correlation of Scale-up Effects on Viscoelastic Behavior," Journal of Composite Materials.

***Frank W. Chambers:** "Operating Air Density Effects Upon Piezoelectric Flow Control Actuator Performance," to be submitted to the AIAA, January, 2001.

***William A. Crossley:** "A Computational Investigation of Approximation Techniques for Engineering Design Optimization," to be submitted to AIAA Conference, TBD.

***Ayodeji O. Demuren:** "Analysis of Optimum Parameters for Stability and Convergence for the Solution of the Poisson Equation in Parallel," to be submitted to the Journal of Computational Physics.

***George S. Devendorf:** "A Universal Model for Predicting Gaseous and Particulate Emissions from Biomass Burning," submission TBD.

***Amin N. Dharamsi:** Anticipated paper to be presented to Journal of Applied Physics and Applied Optics.

***David A. Dryer:** "A Framework for Introductory Training of Distributed Collaborative Environments," agency TBD.

***Mark Farris:** "Hamiltonian Formulations and Conservation Laws for Fluid Flow," to be submitted to the Journal of Sound and Vibration.

***Thomas A. Gally:** "Aerodynamic Evaluation of Tip-Mounted Jet Nacelles," to be submitted to Aircraft Design.

***Myron Ginsberg:** "Utilizing NASA-Supported Hardware, Software, and Algorithm Technologies to Solve Large-Scale Applications for the U.S. Automotive Industry," to be submitted to the 6th NASA Symposium on Large-Scale Analysis and Design on High Performance Computers and Workstations, October, 2001, Williamsburg, VA.

***Peyman Givi:** A paper is being prepared for submission to the Journal of Fluid Mechanics.

***Walter T. Golembiewski:** Anticipated: International Symposium on Smart Structures and Microsystems 2000, Oct. 19-21, 2000, Hong Kong; 35th Intersociety Energy Conversion Engineering Conference, July 24-28, 2000, Las Vegas, NV.

***Jagannathan V. Iyengar:** Anticipated submission to Decision Sciences Journal and Human Factors Journal.

***Mark D. Lee:** Possible submission to Human Factors and Ergonomics Society Conference 2000.

Garrick E. Louis: "A Risk-Based Method for Evaluating NASA Technologies for Use in the National Airspace System," International Mechanical Engineering Congress (ACME) - Safe Engineering and Risk Analysis Division, Nov. 5-10, 2000, Orlando, Florida.

***Duc T. Nguyen:** "Efficient Sparse Assembling Procedures for Finite Element Acoustics/Structures/Electromagnetics Engineering Applications," Agency TBD.

***Ronald J. Pollock:** Anticipated presentation at the Pennsylvania State University.

Lawrence W. Rehfield: "Behavior of Slender Beams Designed for Bending-Twist Coupling," AIAA 43rd SDM Conference.

Jeng-Jong Ro: "Finite Element Modeling of Synthetic Jet Actuator," SPIE's 8th International Symposium on Smart Structures and Materials, March 4-8, 2001.

George T. Rublein: "Local Axiom for Thermodynamics," American Mathematics Monthly.

***M. Roman Serbyn:** Anticipate submitting a paper as co-author to the ISA sponsored 47th International Instrumentation Symposium to be held in Denver, CO, May, 2001.

***Larry E. Tise:** Will be submitting a book transcript on the Wright Brothers to the University of North Carolina in January, 2001.

***Jerry H. Tucker:** Anticipate a NASA Technical Brief to the AIAA, March, 2001.

***Gregory M. Wilkins:** "A Study of Anisotropic Materials in Electronic Devices Using Prismatic Elements," hope to submit to IEEE Transactions on Antennas and Propagation and/or Microwave Theory and Techniques.

Keith M. Williamson: "Pressure Partition Model for FSW," Welding Journal; "Theoretical Effects of Joint Geometry on FSW Lap Joints," Computational Materials Science Journal.

***James P. Withington:** Paper should be published on, "Web Site Use Statistics" for Educational Web Site.

Anticipated Research Proposal Submission

Beckry M. Abdel-Magid: “The Synergistic Effects of Temperature and Moisture on the Viscoelastic Behavior of Polymeric Composites.” to be submitted to NASA.

Frank W. Chambers: “Altitude Effects on Piezoelectric Flow Control Actuator Performance,” NASA Langley Research Center.

William A. Crossley: “Response Surfaces in Engineering Design Optimization,” planned submission to NASA LaRC.

Dianne DeTurris: “Subsonic Glideback Rocket Demonstrator Flight Testing,” NASA LaRC.

David A. Dryer: Potential proposal to ISE program supporting collaborative engineering user interface tasks.

Walter T. Golembiewski: PATENT PENDING: NASA Case No. LAR16136-1-CU, entitled, “Networked Array Circuitry for Power Allocation and Distribution (PAD), grant NCC1-280.

Monson H. Hayes: “Compression of Interferograms in an Imaging FTS,” NASA LaRC.

Jagannathan V. Iyengar: Possible grant proposal with NASA Funding Agency for Fall 2000.

Mark D. Lee: “Studying the Cognitive and Neural Mechanisms of Skill Acquisition and Transfer Across Sensory Modalities,” submitted to Office of Naval Research.

Garrick E. Louis: “Maximizing the Benefits of Airport Capacity Research at NASA-Ames and Aviation Safety Research at NASA-Langley Through the Use of Strategic Risk Management,” Unsolicited Proposal to NASA LaRC.

Patricia F. Mead: “Tunable Single Frequency Fiber Optic Laser for Fiber Optic Sensor Applications,” agency TBD.

Duc T. Nguyen: “Efficient Sparse Assembling Procedures for Unsymmetrical System of Equations,” Agency TBD; “Efficient and User Friendly Out-of-Core Sparse Equation Solvers,” Agency TBD.

William L. Nichols: NASA-PAIR: “Mars Winds: An Alternative Energy Source Collaborative.”

Ronald J. Pollock: Collaborating with NASA on current project and a project involving nanotube production.

Lawrence W. Rehfield: "Elastic Tailoring of Aerospace Structures," proposed to NASA LaRC's Mechanics and Durability Branch.

George T. Rublein: Anticipated Interdisciplinary Capstone course for secondary math teachers, to NSF.

M. Roman Serbyn: "A Low-Cost Robust Vibration Controller," internal NASA proposal; "Requirements for a New Microphone Array," NASA LaRC.

Arthur C. Taylor, III: Anticipate submitting internal proposal to NASA LaRC with ASEE Associate.

Larry E. Tise: Will be submitting a new research proposal to NASA Langley in the fall, 2000.

Gregory M. Wilkins: "Computational Numerical Electromagnetics for the Solution of Guided-Wave and Radiating Problems," to be submitted to NASA Faculty Awards for Research (FAR) program, as well as other programs.

Keith M. Williamson: "Thermomechanical Analysis of FSW," NSF; "Optimization Study for FSW Lap Joints," NASA.

Funded Research Proposals

Beckry M. Abdel-Magid: "Composite Reinforcement of Wood Structures," NASA and University of Maine.

William A. Crossley: "Actuator Placement via Genetic Algorithm for Aircraft Morphing," NASA Langley Research Center; "Aerodynamic Shape and Structural Topology Design of Rotor Cross-Sectors Using a Genetic Algorithm," NASA Ames.

Dianne DeTurris: "High Power Rocket Demonstrator of a Reusable Glideback Booster," NASA LaRC; "Electric Thruster Testing in 30 Inch High-Vacuum Chamber," California University Faculty Support Grant.

Peyman Givi: AFOSR; NASA Glenn Research Center.

Jagannathan V. Iyengar: University of Nebraska - Research Grant - Office of Sponsored Programs, Nov. 99 to Sept. 00.

Mark D. Lee: "Analysis of Aviation Accident Reports to Identify Weather Information Requirements," GSRP.

Garrick E. Louis: “A Consortium for Integrated Municipal Sanitation Systems,” National Science Foundation.

Patricia F. Mead: “Packaging of Reliability of Optoelectronic Components,” NSF; “Space Deployed Electronic Packages,” NASA Goddard Space Flight Center.

Duc T. Nguyen: “Simplex Domain Decomposition Procedures Under MPI Parallel Computer Environments,” supported by NASA GSRP Research Grant.

William L. Nichols: “The Potential for Wind Energy Generation on Mars,” Montana Space Grant; “Building a Bridge to NASA for Tribal College Students,” Montana Space Grant.

George T. Rublein: “Measurement Course for In-Service Teachers,” State Council of Higher Education for Virginia.

Arun K. Verma: “EMIT (Enhancing Mathematics Instruction Using Technology),” Department of Education.

Keith M. Williamson: “Design of Green Mfgr Pallet Using Waste Materials,” Sorbilite Corporation.

James P. Withington: “Low-Cost Mechanical Engineering Laboratory Automation,” National Science Foundation.

SECTION VI

SUMMARY OF PROGRAM EVALUATION

A program evaluation questionnaire was given to each Fellow and to each Research Associate involved with the program. The questions and the results are given below and on the following pages from the forty of forty evaluations were returned (100%).

A. Program Objectives

1. Are you thoroughly familiar with the research objectives of the research (laboratory) division you worked with this summer?

Yes	<u>36</u>	(90%)
No	<u>4</u>	(10%)

2. Do you feel that you were engaged in research of importance to your Center and to NASA?

Yes	<u>39</u>	(98%)
No	<u> </u>	
No Response	<u>1</u>	(2%)

3. Is it probable that you will have a continuing research relationship with the research (laboratory) division that you worked with this summer?

Yes	<u>30</u>	(75%)
No	<u>0</u>	(3%)
Uncertain	<u>10</u>	(25%)

4. My research colleague and I have discussed follow-up work including preparation of a proposal to support future studies at my home institution, or at a NASA laboratory.

Yes	<u>27</u>	(68%)
No	<u>5</u>	(12%)
Uncertain	<u>8</u>	(20%)
N/A	<u> </u>	

5. Are you interested in maintaining a continuing research relationship with the research (laboratory) division that you worked with this summer?

Very much so	<u>38</u>	(95%)
Somewhat	<u>2</u>	(5%)

B. Personal Professional Development

1. To what extent do you think your research interests and capabilities have been affected by this summer's experience? You may check more than one.

Reinvigorated	<u>20</u>	(50%)
Redirected	<u>14</u>	(35%)
Advanced	<u>27</u>	(67%)
Barely maintained	<u> </u>	
Unaffected	<u> </u>	

2. How strongly would you recommend this program to your faculty colleagues as a favorable means of advancing their personal professional development as researchers and teachers?

Positively	<u>40</u>	(100%)
Not at all	<u> </u>	
No Reply	<u> </u>	

3. How will this experience affect your teaching in ways that will be valuable to your students? You may check more than one.

By integrating new information into courses	<u>30</u>	(75%)
By starting new courses	<u>7</u>	(17%)
By sharing your research experience	<u>38</u>	(95%)
By revealing opportunities for future employment in government agencies	<u>26</u>	(65%)
By deepening your own grasp and enthusiasm	<u>26</u>	(65%)
Will affect my teaching little, if at all	<u>1</u>	(2%)
No Response	<u> </u>	

4. Do you have reason to believe that those in your institution who make decisions on promotion and tenure will give you credit for selection and participation in this highly competitive national program?

Yes	<u>26</u>	(65%)
No	<u>13</u>	(35%)
No Answer	<u>1</u>	(2%)

C. Administration

1. How did you learn about the Program? Check appropriate response.

Received announcement in the mail	<u>15</u>	(40%)	No Answer - 3 (8%)
Read about in a professional publication	<u>6</u>	(20%)	
Heard about it from a colleague	<u>15</u>	(40%)	
Other (Explain below)	<u>5</u>	(13%)	

Previous ASEE Fellow; LaRC NASA Web Site (3); Saw a posted announcement; Through a visit to NASA Langley; Recruited by LaRC OEd staff from a group of tribal college faculty;

2. Did you also apply to other summer faculty programs?

Yes 10 (25%) No 30 (75%)

<u>1</u>	DOE
<u>5</u>	Another NASA Center
<u> </u>	Air Force
<u>1</u>	Army
<u>3</u>	Navy

3. Did you receive an additional offer of appointment from one or more of the above? If so, please indicate from which.

Yes 6 (15%) No 21 (53%) No Answer 13 (32%)

4. Did you develop new areas of research interests as a result of your interaction with your Center and laboratory colleagues?

Many	<u>10</u>	(25%)	None	<u>2</u>	(5%)
A few	<u>28</u>	(70%)	No reply	<u> </u>	

5. Would the amount of the stipend (\$1,000 per week) be a factor in your returning as an ASEE Fellow next summer?

Yes 29 (73%) No 11 (27%)

If not, why? I am more interested in accomplishing research outcomes; Stipend is marginal for someone from a long distance away; I think they should try to be more competitive.

6. Did you receive any informal or formal instructions about submission of research proposals to continue your research at your home institution?

Yes 27 (67%)
 No 13 (33%)
 No reply _____ (0%)

7. Was the housing and programmatic information supplied prior to the start of this summer's program adequate for your needs?

Yes 37 (93%)
 No 2 (5%)
 Somewhat 0 (0%)
 Not Applicable 1 (2%)

8. Was the contact with your research colleague prior to the start of the program adequate?

Yes 38 (96%)
 No 1 (2%)
 Somewhat 0 (0%)
 No Answer 1 (2%)

9. How do you rate the seminar program?

Excellent 22 (55%)
 Good 14 (35%)
 Fair 3 (8%)
 Poor _____ (0%)
 No reply 1 (2%)

10. In terms of the activities that were related to your research assignment, how would you describe them on the following scale?

Check one per activity				
Activity	Adequate	Too Brief	Excessive	Ideal
Research	16 (40%)	10 (25%)	0 (0%)	14 (35%)
Lectures	27 (68%)	1 (2%)	3 (8%)	8 (20%)
Tours	19 (48%)	3 (8%)	2 (5%)	15 (37%)
Social/Rec.	22 (55%)	3 (8%)	2 (5%)	11 (28%)
Meetings	23 (58%)	2 (5%)	1 (2%)	11 (28%)

11. What is your overall evaluation of the program?

Excellent	<u>34</u>	(85%)
Good	<u>6</u>	(15%)
Fair	<u> </u>	(0%)
Poor	<u>0</u>	(0%)

12. If you can, please identify one or two significant steps to improve the program.

See Fellows' Comments and Recommendations

13. For second-year Fellows only. Please use this space for suggestions on improving the second year.

See Fellows' Comments and Recommendations

D. Stipend

1. To assist us in planning for appropriate stipends in the future, would you indicate your salary at your home institution?

\$ 59,090.2* per Academic year x or Full year .
 Median Range *Based on 33 professors' salaries provided.

2. Is the amount of the stipend the primary motivator to your participation in the ASEE Summer Faculty Fellowship Program?

Yes 4 (10%) No 15 (38%) In Part 19 (47%) No Answer 2 (5%)

3. What, in your opinion, is an adequate stipend for the ten-week program during the summer of 2000?

\$10K-6 (15%); \$10K or \$11K-1 (2%); \$11K-6 (15%); \$10K to \$12K-1 (2%); \$12K-7 (18%); \$12.5K-1 (2%); \$12K to \$18K-1 (2%); \$13K-2 (5%); \$14K-1 (2%); \$15K- 8 (20%); \$20K- 3 (8%); \$10K with Housing or \$20K without housing-1 (2%); Not Indicated-2 (5%)

Several suggested that the relocation allowance was inadequate for those having to maintain two households during the summer. It was recommended that either the stipend be significantly increased, the relocation allowance be significantly increased, or a combination of the two. Should be raised because it has been the same for years.

E. American Society for Engineering Education (ASEE) Membership Information

1. Are you currently a member of the American Society for Engineering Education?

Yes 11 (28%) No 29 (72%)

2. Would you like to receive information pertaining to membership in the ASEE?

Yes 19 (48%) No 16 (40%) Not Indicated 5 (12%)

Fellows' Comments and Recommendations

Both ASEE Fellows and NASA Associates were asked to provide comments and recommendations relative to their participation in an effort to provide continuous improvement in the quality of the ASEE Program. Below are the responses received.

- Although I was a Fellow last year, I was at JPL. Both programs are **very beneficial**.
- More professional seminars, and more relevant information on proposal procedures.
- Create a web page for the program.
- Add a couple more weeks to the program.
- Improve lectures. Perhaps split from LARSS program.
- If the EDCATS questionnaire could be combined with this survey, it would save some of the paperwork.
- When applying and accepted, it would help to know more about the day-to-day activities of the department. My initial question was what will I do all day? How will my day be broken down? I was not participating in any research experiment although I felt I was expected to. My dept. Simply doesn't participate in that type of work. I took the initiative to use the resources available to learn some new technology. My self-determination and motivation kept me very busy. It is a luxury to be surrounded by people with expertise to answer questions that arise. The ASEE program was very beneficial to me professionally. It is very well run and organized. I would recommend it to my colleagues. But realize that faculty from community colleges sometimes may have more to gain than to give.
- More Lecture series in the areas of Competencies.
- Increase stipend and decrease the paperwork.
- Provide a way to follow-up on research project immediately after the end of summer.
- It's (the program) great like it is. Maybe more web-based content or schedule changes/upcoming event details.
- Cheaper housing opportunities for families.
- Overall program was well-organized. Perhaps less expensive housing may be located.
- Allow travel funds to pay for hotel accommodations enroute for those that drive long distances.
- There should be better and coherent computer support. Lectures should be on new research, not just program organization.
- Don't combine anything with the LARSS people. Eliminate all but research from the program. I prefer zero time on stuff like this (lectures, tours, social/recreational, meeting).
- More professional interaction with other Fellows with a view towards future collaboration.
- Include more interaction with LARSS Students in research teams.
- Need more information on housing. Maybe another simple picnic. Have civil servant level of computer access both on and off the center and also when returning home. Jump start the project with an early visit. Return visit to further the project.

Fellows' Comments and Recommendations Continued

- Include bi-weekly opportunities for faculty to formally meet and share ideas. Offer a 2-day writing workshop so faculty have the chance to draft papers for journal submission.
- Support in the form of working computer/printer up front at the start.
- Workshop or panel with past Fellows who can share important information. More information on how to initiate a proposal for follow-on funding early in the program.
- Provide a seminar on research opportunities at NASA early in the program. Allow at least 2 weekdays for Fellows to tour Hampton during the day. I was at work from 8-4:30 each weekday, then went home on weekends, so after 10 weeks, I barely got to see the place!
- Raise the stipend to DOD level.
- I have totally enjoyed the project and look forward to continuing to work with it.
- The seminars were of very mixed quality and better speakers should be chosen. Perhaps the ASEE and LARSS programs should have separate presentations. Jerry Creedon and Dennis Bushnell should be invited to speak. The stipend and relocation allowance are marginal and certainly prevent some young faculty from considering the program. The relocation allowance does not cover the additional costs of living away from home, and paying the same stipend to those in the area living at their permanent house seems unfair.
- I supplemented my housing search using the www.hamptonroads.com links for apartments.
- I listed an "excessive" amount of time for lectures, but this reflects my impression that the talks were really directed towards the LARSS students. I appreciate the wide range of topics, but there were a few lectures that I might have passed on.
- Excellent organization and activities. Debbie Murray does a great job.
- ASEE has a program for new faculty where the institution pays for one year and the second is free. I e-mailed the contact person listed on the web site for more information, but never received a reply.
- When I began the program on June 5, I was under the supervision of Mr. Fred Beck. As of July 3, Mr. Beck, his supervisor, Tom Campbell, and his colleague, C. Cockrell, retired from the branch. I am now under the supervision of Dr. Marion C. Bailey. I have spoken with him regarding a continued collaborative relationship, but I have concerns as a reorganization is pending. I will submit a proposal of anticipated work with the organization.
- I would like to add that for a person who is a historian, this program has been a God send. There is no way I could have found the concentrated time to grapple with the extensive Wright papers published and unpublished works in my regular employment. The fellowship allowed me to virtually write the book I had in mind which will reveal the Wright Brothers and their family and involvement with Kitty Hawk as a community in an entirely new light. Thank you for this opportunity.
- It is insulting to the Faculty to hold any paycheck hostage to delivering administrative forms and the like.
- Excellent job! Keep up the good work. Debbie is outstanding and very energetic, charming, and efficient. Increase the stipend. The stipend was the same when I was much younger.

Fellows' Comments and Recommendations Continued

- Some seminars were good, but the talk given by Dr. Flores from Ames Research Center was not. He talked either over the heads of the students and below the professors, or he treated us all like children.
- This is a well conceived, well balanced and exciting program that has obviously been fine tuned over the years of existence. Since a number of participants also apply for other, similar programs, it would be helpful to have the acceptance/offer dates the same, at least for those programs administered by ASEE. The choice of finalist for the "Best Presentation Competition" was not based on their presentations: either correct this or change the name of the award. The administrators of the program did a great job. Mrs. Debbie Murray and Dr. Qamar Shams were outstanding in their roles.
- The library provides excellent service and the personnel are very helpful. It would be a great advantage to have books until the end of the program and library access once returning home.
- Please caption group photos with names of all individuals shown. Please have the proposal seminar at the end of the 4th week or beginning of the 5th so we have time to develop proposals in collaboration with NASA experts. Please include in advance packet info on the Air Force Base and Fellows access to resources there, including a map. Please keep all the five features of the program - lectures, tours, Officers Club banquet, frequent communications, etc.
- I am pleased to be associated with such high level researchers and facilities.

SUMMARY OF ASSOCIATES' EVALUATION

The following comments and recommendations were taken from the questionnaire distributed to the ASEE Associates requesting them to evaluate the overall performance of their ASEE Fellow. Most all of the Associates responding indicated an overwhelming satisfaction with the Fellow's knowledge of their subject, diligence, interest in assignment, and enthusiasm. A total of twenty-eight evaluations were returned. See statistics based on the number returned below:

- 100% aware of participation as Associate prior to start of program
- 93% contacted Fellow prior to start of program
- 96% stated Fellows accomplished established research goals with a high level of satisfaction
- 89% interested in serving as Associate again (one-no due to retirement)
- 82% indicated there was discussion of possible follow on research via submission of a proposal

SUMMARY OF ASSOCIATES' EVALUATION Continued

- 88% with first year Fellows indicated a desire to continue research with the 2001 program
- 60% indicated their Fellow was above average when compared overall with other faculty researchers they had worked with before
- 90% indicated the programmatic support/operations of the Office of Education was outstanding/exceptional.

Research Associates' Comments

- Great flexibility in ASEE staff allowed Fellow to start and end the program a week early.
- Program seemed well-organized and complete.
- Thanks for all the help!
- No suggestions - An excellent program.
- Again, it's been a pleasure to participate in this very worthwhile program.

Research Associates' Recommendations

- Keep it the same as it is. Program works fine.
- It may be a good idea to have a half-day or one-day presentation in the middle or end of the program, so all the researchers have a chance to talk about their research results.
- I think the ASEE Fellows could be given more flexibility in their interactions with the Office of Education and with NASA; for example, relax the expectation for Fellows to attend seminars. In general, the ASEE Fellows are treated like high school or college students. The general implication that LARSS students and ASEE Fellows are in some way alike, was offensive to my Fellow. The Office of Education did respond favorably and quickly to my Fellow's request for deviation to his established ASEE schedule.
- No recommendations come to mind.

SECTION VII

CO-DIRECTOR'S RECOMMENDATIONS

1. It is wholeheartedly, and enthusiastically recommended that the program continue. It is a valuable and effective means of contributing to the research objectives of the NASA Langley Research Center, it enriches and refreshes the faculty and their home institutions, and it furthers the professional knowledge of the participating faculty. These conclusions are supported by the assessment and evaluation instruments given to the faculty participants, and the NASA research associates.
2. The informal luncheons following the lectures were very successful. This occasion provided and excellent opportunity for the faculty participants to discuss the lecture topic and related concerns in depth with the guest lecturers, and also develop professional contacts that will aid and enhance their professional development.
3. It is recommended that the application distribution to Divisions included as an outcome, a ranking of the non-selected applicants. The process of filling vacated slots would be greatly facilitated by having documented assessment of the ranking of the applicants with respect to 1) relevance to NASA Langley's Divisional research interest, 2) relevance to NASA research interest, 3) capabilities and research background of the participant. The non-selected candidates of high rank can become an important pool of applicants to recruit from in subsequent years.
4. It is recommended that the RADIO (Research and Development Interaction Opportunities) activities be expanded and formally included in the national model of the NASA/ASEE program. Similar to the intent of JOVE, the faculty recipients would receive small awards to facilitate student presentations at professional meetings or development and distribution of curricular materials. This recommendation is offered in the spirit of the agency's interest in providing the broadest dissemination of NASA research results to the public. This activity is a cost effective method of providing this E/PO service.

APPENDIX I

2000 NASA Langley ASEE Summer Faculty Fellowship Program Fellows

<u>Name and Institution</u>		<u>NASA Associate & Competency/Program Office</u>
Dr. Tarek M. Abdel-Fattah Christopher Newport University		Dr. Wallace L. Vaughn Structures and Materials
Dr. Beckry M. Abdel-Magid Winona State University		Dr. Thomas S. Gates Structures and Materials
Prof. Janice D. Cawthorn (R) Hampton University		Mr. Michael L. Ruiz Earth and Space Science Program Office
Dr. Frank W. Chambers (R) Oklahoma State University		Dr. Gregory S. Jones Aerodynamics, Aerothermodynamics and Acoustics
Dr. William A. Crossley (P) Purdue University		Dr. Natalia Alexandrov Aerospace Systems, Concepts, and Analysis
Dr. Ayodeji O. Demuren (R) Old Dominion University		Dr. Mark H. Carpenter Aerodynamics, Aerothermodynamics and Acoustics
Dr. Dianne DeTurris California Polytechnic State University		Dr. Theodore A. Talay Aerospace Systems, Concepts, and Analysis
Dr. George S. Devendorf (R) Middle Tennessee State University		Dr. Joel S. Levine Atmospheric Sciences
Dr. Amin N. Dharamsi (R) Old Dominion University		Dr. Jirong Yu Systems Engineering
Dr. David A. Dryer Old Dominion University		Mr. Donald W. Monell Intelligent Synthesis Environment Program Office
Dr. Mark Farris (P) Midwestern State University		Dr. Fereidoun Farassat Aerodynamics, Aerothermodynamics and Acoustics
Dr. Thomas A. Gally (P) Embry-Riddle Aeronautical University		Mr. Richard L. Campbell Aerodynamics, Aerothermodynamics and Acoustics
Dr. Myron Ginsberg University of Michigan		Dr. Jaroslaw Sobieski Aerospace Systems, Concepts, and Analysis

2000 NASA Langley ASEE Summer Faculty Fellowship Program Fellows Continued:

<u>Name and Institution</u>	<u>NASA Associate & Competency/Program Office</u>
Dr. Peyman Givi (R) State University of New York-Buffalo	Dr. J. Philip Drummond Aerodynamics, Aerothermodynamics and Acoustics
Dr. Walter T. Golembiewski Norfolk State University	Dr. Sang H. Choi Structures and Materials
Dr. Monson H. Hayes Georgia Institute of Technology	Mr. Glenn D. Hines Structures and Materials
Dr. Jagannathan V. Iyengar University of Nebraska-Kearney	Dr. Kara A. Latorella Airborne Systems
Prof. Christopher B. Kerns Crownpoint Institute of Technology	Mr. William B. Ball Systems Engineering
Dr. Frank P. Kozusko Hampton University	Dr. Meelan M. Choudhari Aerodynamics, Aerothermodynamics and Acoustics
Dr. Mark D. Lee Old Dominion University	Mr. Daniel B. Shafer Airborne Systems
Dr. Garrick E. Louis University of Virginia	Ms. Vicki K. Crisp Aerospace Systems, Concepts, and Analysis
Dr. Patricia F. Mead University of Maryland-College Park	Dr. Robert S. Rogowski Structures and Materials
Dr. Anne Millbrooke (R) University of Alaska-Fairbanks	Dr. Karen R. Credeur Office of External Affairs
Prof. Felix J. Nevarez Polytechnic University of Puerto Rico	Mr. Kory J. Priestley Atmospheric Sciences
Dr. Duc T. Nguyen (P) Old Dominion University	Dr. Willie R. Watson Aerodynamics, Aerothermodynamics and Acoustics
Prof. William L. Nichols Blackfeet Community College	Mr. Robert Starr Office of Education
Dr. Ronald J. Pollock Pennsylvania State University	Mr. Warren C. Kelliher Systems Engineering

2000 NASA Langley ASEE Summer Faculty Fellowship Program Fellows Continued:

<u>Name and Institution</u>	<u>NASA Associate & Competency/Program Office</u>
Dr. Lawrence W. Rehfield University of California-Davis	Dr. Damodar R. Ambur Structures and Materials
Dr. Jeng-Jong Ro Old Dominion University	Dr. Fang-Jenq Chen Aerodynamics, Aerothermodynamics and Acoustics
Dr. George T. Rublein (R) College of William and Mary	Mr. Roger A. Hathaway Office of Education
Dr. M. Roman Serbyn Morgan State University	Dr. Qamar A. Shams Aerodynamics, Aerothermodynamics and Acoustics
Mr. Mir S. Shirvani (R) New River Community College	Mr. Roosevelt Bryant, Jr. Systems Engineering
Dr. Arthur C. Taylor, III Old Dominion University	Mr. Lawrence L. Green Aerospace Systems, Concepts, and Analysis
Dr. Larry E. Tise First Flight Centennial Commission	Dr. Samuel E. Massenberg Office of Education
Dr. Jerry H. Tucker Virginia Commonwealth University	Mr. Qamar A. Shams Aerodynamics, Aerothermodynamics and Acoustics
Dr. George F. Tucker (P) The Sage Colleges	Mr. Glen W. Sachse Systems Engineering
Dr. Arun K. Verma Hampton University	Mr. Mitchell E. Thomas/Mr. George Allison AAAC/Human Resources
Dr. Gregory M. Wilkins Morgan State University	Dr. Marion C. Bailey Airborne Systems
Dr. Keith M. Williamson (R) Old Dominion University	Mr. Robert A. Hafley Structures and Materials
Dr. James P. Withington (R) Inter American University-Puerto Rico	Mr. Jeffrey M. Seaton Aerospace Systems, Concepts, and Analysis

R-Designates returnees from 1999

P-Designates prior participants from earlier years

APPENDIX II
LECTURE SERIES
PRESENTATIONS BY RESEARCH FELLOWS
CALENDAR OF ACTIVITIES

2000 OFFICE OF EDUCATION SUMMER LECTURE SERIES

Location: H.J.E. Reid Conference Center, Bldg. 1222

14 Langley Boulevard

Time: 11:00 a.m. - 11:45 a.m. - Lecture

11:45 a.m. - 12:00 p. m. - Questions and Answer

<u>DATE</u>	<u>TOPIC</u>	<u>SPEAKER</u>
Tuesday, June 13	A Brief History of Fire on Earth	Dr. Joel S. Levine Atmospheric Sciences Competency Langley Research Center
Tuesday, June 20	Intelligent Synthesis Environment Program Office Overview	Ms. Elizabeth B. Plentovich Intelligent Synthesis Environment Program Office Langley Research Center
Tuesday, June 27	Experiences and Challenges in Mars Exploration	Dr. Robert D. Braun Space Access and Exploration Program Office, Langley Research Center
Tuesday, July 4	Holiday - No Lecture Scheduled	
Tuesday, July 11	Crew Systems Research	Dr. Kelli F. Willshire Airborne Systems Competency Langley Research Center
Tuesday, July 18	Emerging Materials Technologies for Aerospace Applications	Dr. Joycelyn S. Harrison and Dr. Mia Siochi Structures and Materials Competency Langley Research Center
Tuesday, July 25	Research Opportunities at NASA Ames Research Center, An Overview	Dr. Jolin Flores Branch Chief, Advanced Aircraft and Powered Lift Branch, NASA Ames Research Center

Upcoming Lecture

Dr. Jolen Flores
Branch Chief
Advanced Aircraft and Powered Lift Branch

NASA Ames Research Center

July 25, 2000 11:00 - 12:00

H. J. E. Reid Conference Center

ASEE Only

Proposal Seminar

July 24, 2000, 2 - 4 p.m.

H. J. E. Reid Conference Center

NASA Langley Research Center

ASEE Summer Faculty Fellowship Program
and

Langley Aerospace Research
Summer Scholars (LARSS) Program

Office of Education Summer Lecture Series



July 18, 2000
11:00 a.m.

Dr. Joycelyn S. Harrison & Dr. Emilie (Mia) J. Siochi

**Asst. Branch Head & Materials Scientist
Advanced Materials and Processing Branch
Structures and Materials Competency**

Dr. Joycelyn Harrison is the Asst. Branch Head of the Advanced Materials and Processing Branch of the Structures and Materials Competency at NASA Langley Research Center. She received B.S. degrees in Chemistry and in Chemical Engineering from Spelman College and Georgia Institute of Technology in 1987. Subsequently she earned M.S. and Ph.D. degrees in chemical engineering from Georgia Institute of Technology in 1989 and 1993 respectively. She joined then Composites and Polymers Branch in 1994 after gaining experience as an NRC post-doctoral associate for one year. Her research in smart materials focuses on the development of high performance electroactive and electrostrictive polymers. She also manages the Materials research program within NASA's Aircraft Morphing Program.

Dr. Mia Siochi is a Materials Scientist in the Advanced Materials and Processing Branch, Structures and Materials Competency, at NASA Langley Research Center. She received a B.S. degree in Chemistry from the Ateneo de Manila University, Philippines. Subsequently she earned a M.S. in Chemistry and a Ph.D. in Materials Engineering Science from Virginia Tech in 1985 and 1989 respectively. After a one year post-doc stint at Virginia Polytechnic Institute and State University, she joined Lockheed Martin Engineering and Sciences Co. as a contractor, providing polymer characterization support for the Composites and Polymers Branch at NASA Langley Research Center. Soon after joining the civil service ranks in 1998, she got involved with Biomimetics/Nanotechnology research to develop biologically inspired, nanoscale materials.

Emerging Materials Technologies for Aerospace Applications

The challenge in materials development for aerospace applications has always been the need to find materials that are lightweight, which do not sacrifice the excellent properties such as high temperature stability, strength and stiffness required for structural components. In recent years, these requirements have been met with high temperature matrix resin composites that are carbon fiber reinforced. NASA is now embarking on the search for the next generation of revolutionary materials that will go beyond lightweight, high strength materials to those that will allow us to build intelligent systems. In the past five years, the Advanced Materials and Processing Branch has led efforts in the development of electroactive materials for smart sensors and actuators. It is now poised to extend the Smart Materials development effort into new territory based on biologically inspired processes. This talk will discuss accomplishments in the Smart Materials development program, and where it is headed, as well as plans for revolutionary materials development based on biomimetics and nanotechnology.

2000 ASEE/LARSS Calendar of Activities

<u>Date</u>	<u>Function</u>
Monday, June 5	ASEE/LARSS Orientation Program - 9:00 a.m. H.J.E. Reid Conference Center, 14 Langley Boulevard ASEE Ice-Breaker - 5-7 p.m. - H.J.E. Reid Conference Center
Friday, June 9 11:30 a.m.	ASEE Spouses Luncheon - Golden Corral Restaurant - 1123 W. Mercury Blvd
Tuesday, June 13	Lecture-H.J.E. Reid Conference Center - <i>LARSS Pay Date</i>
Wednesday, June 14	ASEE/LARSS Picnic-H.J.E. Reid Conference Center Picnic Grounds - 4:00 p.m. - 8:00 p.m.
Tuesday, June 20	Lecture-H.J.E. Reid Conference Center - <i>ASEE Pay Date</i>
Thursday, June 22	LARSS Langley Air Force Base Tour 1:30 - 3:00 p.m.
Friday, June 23	LARSS NASA CAVE and Simulator Tour
Tuesday, June 27	Lecture-H.J.E. Reid Conference Center - <i>LARSS Pay Date</i>
Wednesday, June 28	Individual Flight Suit Photos behind the Hangar, B. 1244 8:30-9:30 a.m. - ASEE 9:30-11:30 a.m. - LARSS
Thursday, June 29	Model Shop Tour B. 1238B - Meet in front of Building LARSS - 8:00 - 9:00 a.m. ASEE - 1:00 - 2:00 p.m.
Friday, June 30	ASEE NASA CAVE and Simulator Tour - Meet in lobby of B. 1268A Arrive 15 Minutes Early and bring badge CAVE Group I - 9:15 - 10:00; CAVE Group II - 10:00 - 10:45; Sim. 12-12:45
Monday/Tuesday, July 3-4	Holiday
Thursday, July 6	ASEE Proposal Seminar-H.J.E. Reid Conference Center 2-4 p.m. <i>ASEE Pay Date</i>
Tuesday, July 11	Lecture-H.J.E. Reid Conference Center - <i>LARSS Pay Date</i> - GROUP PHOTOS
Thursday, July 13	LARSS Graduate Seminar - 12:30 p.m.
Friday, July 14	ASEE Langley Air Force Base Tour 1:30 - 3:00 p.m. Meet in parking lot of 1216T1 at 1:00 p.m.
Tuesday, July 18	Lecture-H.J.E. Reid Conference Center - <i>ASEE Pay Date</i>
Thursday, July 20	Small Disadvantaged Business/University Opportunities Forum
Tuesday, July 25	Lecture-H.J.E. Reid Conference Center - <i>LARSS Pay Date</i> ASEE EDCATS Evaluation input (1216, Rm. 112-114)
Thursday, July 27	LARSS 7 X 10 Wind Tunnel Tour 11:30 a.m. - 12:15 p.m. - Meet in front of B. 1212
Friday, July 28	ASEE 7 X 10 Wind Tunnel Tour 1:00 - 1:45 p.m. - Meet in front of B. 1212
Saturday, July 29	LARSS Career Fair
Tuesday, August 1	<i>ASEE Pay Date</i> - H. J. E. Reid Conference Center - Hampton Room 10 - 11 a.m.
Thursday, August 3	ASEE/LARSS Banquet-LAFB O'Club
Tuesday, August 8	ASEE Final Presentations and Best Research Presentation Competition-H.J.E. Reid Conference Center
Friday, August 11	Last Day of Program - <i>Final ASEE/LARSS Pay Date</i> - Process Out 2 - 4 p.m. - H.J.E. Reid Conference Center - Hampton Room

APPENDIX III - GROUP PICTURE OF ASEE FELLOWS

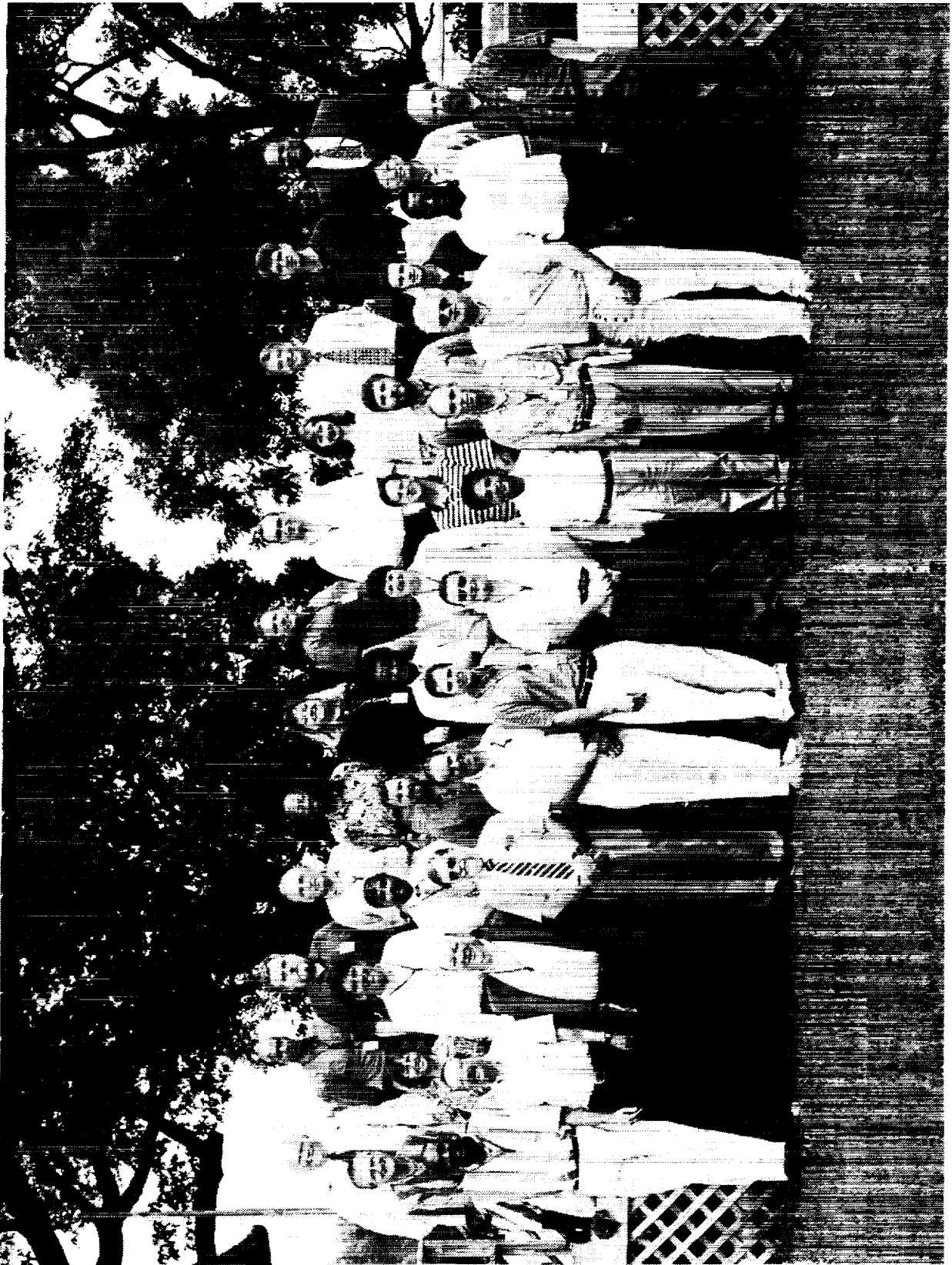

Those pictured in group photograph from left to right are:

Front Row Standing: Dr. Garrick E. Louis, Dr. Frank W. Chambers, Dr. Myron Ginsberg, Dr. Jerry H. Tucker, Dr. Frank P. Kozusko, Prof. Felix J. Nevarez, Dr. Tarek M. Abdel-Fattah, Dr. Jagannathan V. Iyengar, Dr. Monson H. Hayes, Dr. Walter T. Golembiewski, Dr. Keith M. Williamson, Dr. Mark Farris

Second Row Sitting: Dr. Larry E. Tise, Dr. Anne Millbrooke, Prof. Christopher B. Kerns, Dr. Arun K. Verma, Dr. Ronald J. Pollock, Dr. Beckry M. Abdel-Magid, Prof. Janice D. Cawthorn, Dr. George S. Devendorf, Dr. Thomas A. Gally, Dr. James P. Withington, Dr. Jeng-Jong Ro

Third Row: Dr. Lawrence W. Rehfield, Dr. Gregory M. Wilkins, Dr. George Tucker, Dr. M. Roman Serbyn, Dr. Patricia F. Mead, Mrs. Deborah B. Murray (ASEE Program Manager/Admin. Asst.), Prof. William L. Nichols, Dr. Mark D. Lee, Dr. Dianne DeTurris, Dr. David A. Dryer, Dr. William A. Crossley, Dr. William P. Marable (ASEE Co-Director)

Not Pictured: Dr. Ayodeji O. Demuren, Dr. Amin N. Dharamsi, Dr. Peyman Givi, Dr. Duc T. Nguyen, Dr. George T. Rublein, Prof. Mir S. Shirvani, Dr. Arthur C. Taylor, III

APPENDIX IV

**DISTRIBUTION OF FELLOWS BY UNIVERSITY RANK
and
DISTRIBUTION OF FELLOWS BY COMPETENCY/PROGRAM OFFICE**

Distribution of 2000 ASEE Fellows by University Rank

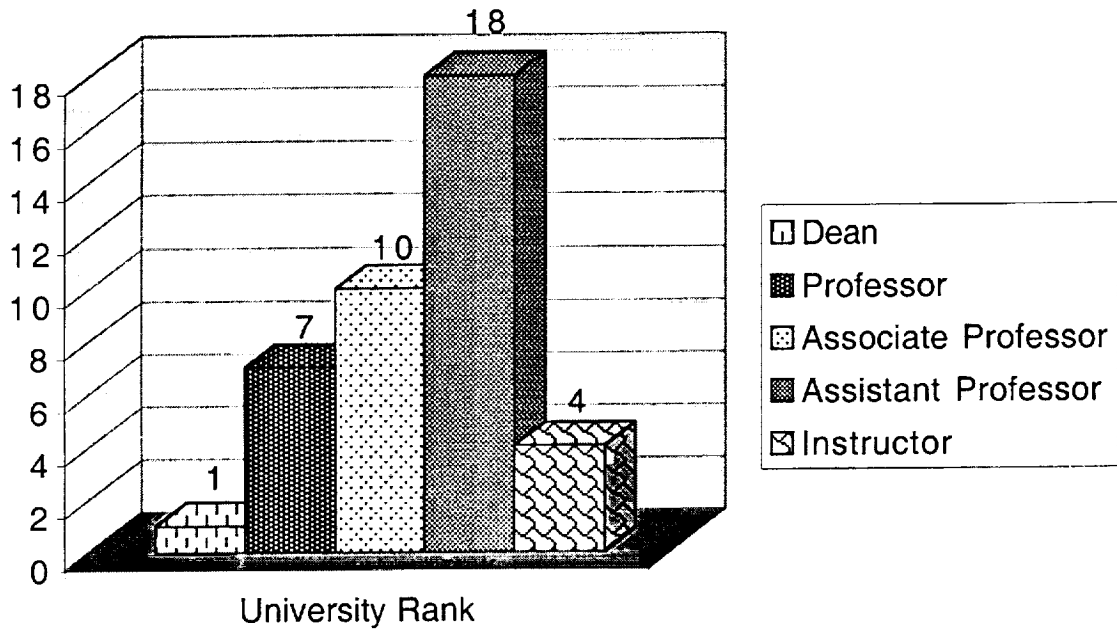

Distribution of 2000 ASEE Fellows by Competency/Program Office

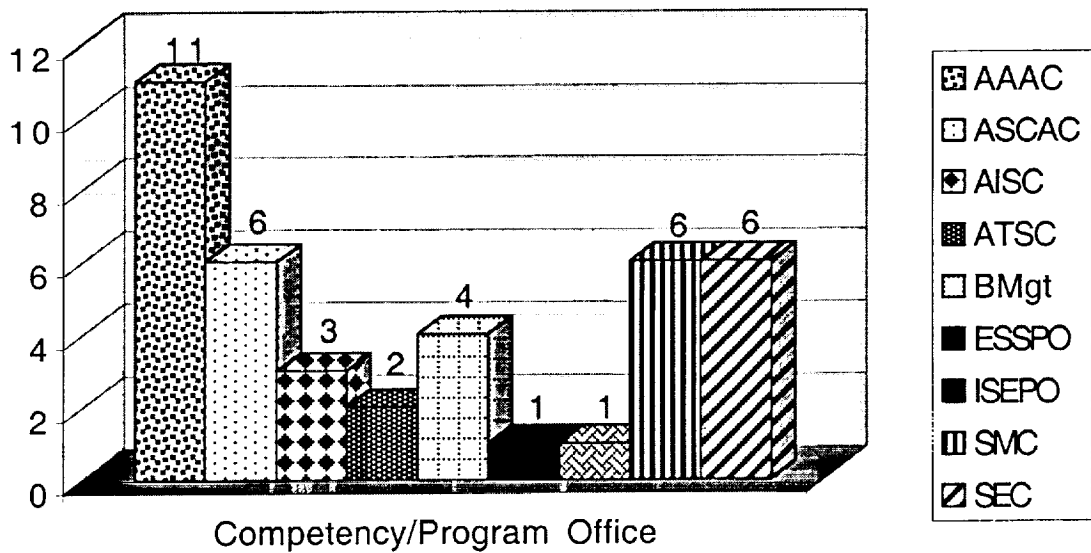

APPENDIX V

**DISTRIBUTION OF FELLOWS BY ETHNICITY/FEMALE
and
DISTRIBUTION OF FELLOWS BY ETHNICITY/MALE**

Distribution of 2000 ASEE Female Fellows by Ethnicity
4 Female Participants
(Represent 10% of all participants)

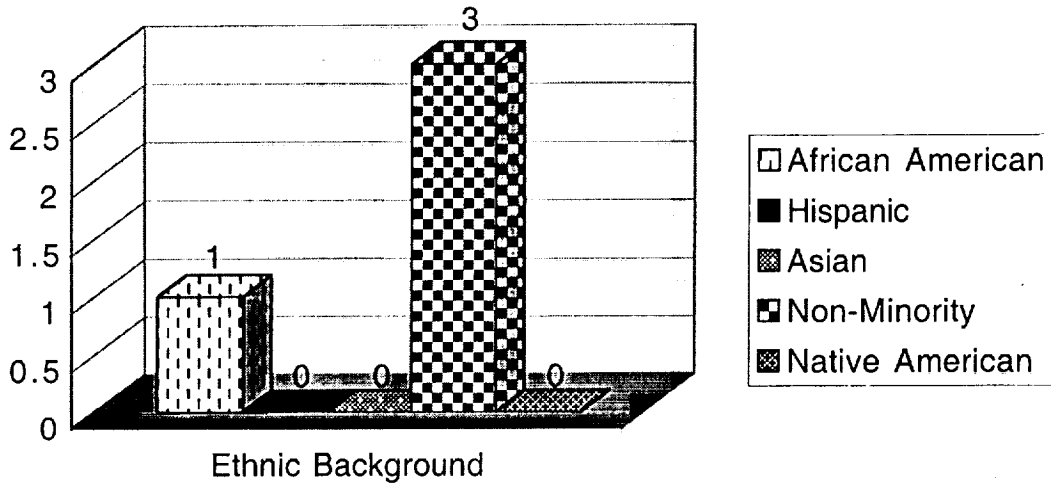

Distribution of 2000 ASEE Male Fellows by Ethnicity
36 Male Participants
(Represent 90% of all participants)

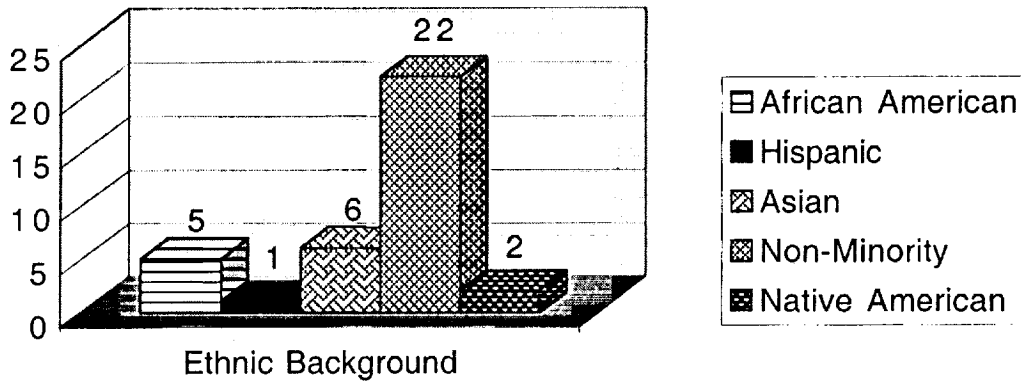

APPENDIX VI

2000 ASEE SUMMER FACULTY FELLOWSHIP PROGRAM DISTRIBUTION OF FELLOWS BY UNIVERSITY PARTICIPATION

<u>UNIVERSITY/COLLEGE</u>	<u>NO. OF FELLOWS</u>
^Blackfeet Community College	1
California Polytechnic State University	1
Christopher Newport University	1
College of William and Mary	1
^Crownpoint Institute of Technology	1
Embry-Riddle Aeronautical University	1
First Flight Centennial Commission	1
Georgia Institute of Technology	1
*Hampton University	3
~Inter American University - Puerto Rico	1
Middle Tennessee State University	1
Midwestern State University	1
*Morgan State University	2
New River Community College	1
*Norfolk State University	1
Oklahoma State University	1
Old Dominion University	8
Pennsylvania State University	1
~Polytechnic University of Puerto Rico	1
Purdue University	1
State University of New York-Buffalo	1
The Sage Colleges	1
University of Alaska - Fairbanks	1
University of California-Davis	1
University of Maryland	1
University of Michigan-Dearborn	1
University of Nebraska-Kearney	1
University of Virginia	1
Virginia Commonwealth University	1
Winona State University	1
Total Number of Fellows	40

Total Number of Institutions Represented **30**

*Indicates a **H**istorically **B**lack College or University (HBCU).

^Indicates a **T**ribal College or University (TCU).

~Indicates a **H**ispanic **S**erving Institution (HSI).

APPENDIX VII

ABSTRACTS - RESEARCH FELLOWS

Oxidative-Resistive Coatings on Carbon-Carbon Composites for Aerospace Applications

Tarek Abdel-Fattah, Ph.D.
Christopher Newport University
Dept. of Biology, Chemistry and Environmental Science
Newport News, VA 23606
e-mail: fattah@cnu.edu

Carbon-Carbon (CC) composites are principally known as lightweight, very-high-temperature materials with superior thermal shock, toughness, and ablation properties. These properties are emphasized in present aerospace and military applications for CC composites such as rocket nozzles, heat shields, reentry vehicle nose tips, and aircraft brakes. However, CC composites are highly susceptible to oxidation, which creates major problems such as losing their toughness and mass. These problems severely limit the use of CC composites in oxidizing environments. This has led to considerable interest in developing effective methods of oxidation protection, especially for aerospace applications where the high specific strengths and moduli of these materials are especially desirable. In space shuttle orbiter vehicles, the reinforced CC (RCC) materials are protected from oxidation by a two-layer coating system consisting of a porous SiC inner layer sealed with SiO₂ and an outer coating of alkali silicate glass filled with SiC particulate. A problem with the RCC outer coating is that the rate of alkali volatilization from SiO₂ becomes significant in the 1200 °C to 1300 °C range, allowing the loss of the fluxing agent over periods of hours to compromise the complacency and sealing characteristics of the glaze.

The objective of this investigation is to design protective coatings for CC composites for temperatures over 1650 °C. The ceramic precursors, hafnium alkoxide (C₄H₉O)₄Hf and/or copper complex (DENC)₄Cu₄Cl₆O, where DENC is N,N-diethylnicotinamide, were impregnated into the CC composite substrate. Thermal treatment of the composite treated with the precursor in air was done at 220 °C for 3 hours. This resulted in converting the coating into oxide layers of hafnium and/or copper oxides. Heating of the coated samples of CC composites at 2100 °C for 1 hour in helium atmosphere resulted in converting the coating to hafnium and/or copper carbides. Several pretreatment ways of CC composites were explored. These included hafnium precursor, copper precursor, copper followed by hafnium, and hafnium followed by copper. CC composites treated with copper followed by hafnium precursors showed the least percent (~11%) of mass loss at 1000 °C for 30 minutes in air. Compared to a 65% of mass loss in unprotected CC composites, our results show great potential for using the proposed approach. Understanding the processes through characterization is suggested. In addition to that, further investigation is needed for multiple impregnation and heat treatment cycle to produce continuous coatings of significant thickness due to the normally low yield of the precursors.

Accelerated Testing of Polymeric Composites: Correlation of Scale-up Effects on Viscoelastic Behavior

Beckry Abdel-Magid, Ph.D., P.E.
Department of Engineering
Winona State University
Winona, MN 55987
E-mail: Beckry@winona.msus.edu

The long-term exposure of polymeric composite materials to the use-environment, such as pressure, temperature, moisture, and load cycles, results in changes in the original properties of the material. These changes in material properties translate to structural changes that can have a potentially catastrophic effect on load-bearing composite structures. Therefore the study and understanding of the long-term effect of exposure on the time-dependent viscoelastic properties of polymeric composite structures is crucial to their proper design, construction, and safe operation. Two experimental options are used to characterize the viscoelastic properties of polymeric composites: the conventional and time-consuming method of directly measuring the response over longer periods of time, and the second method of using accelerated aging processes to obtain the properties during short-term testing.

In this study an accelerated method is developed using the dynamic mechanical analyzer (DMA) to measure the viscoelastic creep properties of polymeric materials. The objectives of the study is to: investigate the use of the DMA in finding creep properties of advanced composite materials, compare results from DMA creep test with data from conventional creep tests, assess the accuracy of results of the DMA sub-coupon level tests, and investigate the potential of using the DMA in finding the long-term creep properties of composite materials. There are many advantages of using the DMA to characterize the viscoelastic creep properties. These include: automated testing, better control of the test environment, simple preparation of test specimens, and performing of creep test at higher, above T_g , temperatures. However, the flexure-loading mode used in the DMA specimens introduces difficulties of isolating tensile properties from compressive properties of the material. In this study, three experimental procedures, DMA flexure, tensile and compressive creep, were used to compare the results of the DMA testing with pure tension and pure compression behavior. In spite of minor differences in the time shift factor of the creep compliance curves, the DMA results compared favorably with results from the tensile creep tests. Comparison of the DMA results with results from compressive creep tests is underway. Once the comparative study is complete, the DMA method will be used to establish the viscoelastic behavior above the glass transition temperature, T_g . In addition, long-term tests will be performed to validate the developed accelerated test method. Upon validation of the accelerated test method, the test results will be used to develop analytical models to predict the long-term viscoelastic properties of polymeric composites.

Abstract
Summer 2000 ASEE Program at NASA LaRC
Janice Cawthorn, Assistant Professor, Hampton University, Hampton, VA

So what did this wonderful summer hold for me? I was again with the DEVELOP Center and Michael Ruiz. Together we worked with forty-seven (47) students from high schools and colleges across the country. My primary function was to serve as Faculty Advisor to the students. Since I routinely function in this capacity at Hampton University it should be an easy task. And so it was this summer! I spent ten weeks working with my favorite people in the whole world: college and high school students who are VERY BRIGHT and highly motivated.

Since we had only sixteen students last summer, I found this summer to be more challenging than the previous year. I listened, advised, talked, listened and then listened again. I took students to Wytheville, Virginia where they conducted field research for one of our major projects. We toured the town, taking pictures, asking questions, and collecting the information that we needed to complete the research. We visited the Town Engineer, the town's library and museum, the VDOT Station in Wytheville and the Chamber of Commerce. Several students involved in the process will take to Virginia Tech the research, maps and traffic information so that an interactive traffic flow model can be created.

A second task that I was asked to complete, involved being the adult present on a trip to Puerto Rico to attend the Southern Growth Policy Board meeting. We met and talked with many people from across the Southern United States and Puerto Rico. We displayed and explained the DEVELOP Center and its projects to any and all who would listen! We also had the opportunity to visit the newest national art gallery in Puerto Rico. It was a great experience. We were asked to participate in several activities throughout the year as a result of this conference.

Yet another challenge was the locating of the necessary computer resources for the project. I ordered some new software and provided other software to the students who were creating the visualizations for each research project. I learned about the process of creating visualizations from the layering of data from many sources. The process allows us to see a problem and its possible solutions while having many sources of seemingly unrelated data. I believe that this is the power of the Digital Earth Project (DEVELOP). Students at any level can benefit from the critical thinking required when involved in a research project from a problem/solution scenario.

Another activity involved the proof reading of various student presentations and papers, as well as helping the students to learn about grant writing and educational planning. This was a vital part of my role as students must have consistent and critical feedback in order to improve their writing skills as well as their skills for seeking funding for their projects. The editing and proof reading are time intensive activities but very interesting. I learned about each research project and was able to assist in the development of presentations by the students.

Finally, I discussed school issues with the students. Some students were interested in scholarship information and others found that they were uncertain about their college selection. I acted as a sounding board and source of information for those who had these kinds of questions. I had the opportunity to meet with LaRC's Director and many of the Associate and Assistant Directors as I supported the students' research projects.

I enjoyed this summer at NASA and plan to continue to use the experience to invigorate my teaching at Hampton University. I have, again, come away with many ideas and much enthusiasm for the programs at NASA LaRC. I feel privileged to have this opportunity.

Density and Mach Number Effects on Piezoelectric Flow Control Actuator Performance

Frank W. Chambers, Ph.D., P.E.
School of Mechanical and Aerospace Engineering
Oklahoma State University
Stillwater, OK 74078-5016
E-mail: fchamb@ceat.okstate.edu

Piezoelectric flow control actuators have been proposed for use in delaying boundary layer separation and suppressing the aeroacoustic resonance of flow over open cavities. The most common actuators are comprised of small cavities with flexible walls and an aperture to the flow that is to be controlled. The application of voltage to piezoelectric wafers attached to the walls changes the volume of the cavity and expels vortices through the aperture. The actuator is driven at the vibro-acoustic resonant frequencies of the system, producing a train of vortices that coalesce in mean flows that are termed synthetic jets. Research conducted with Dr. G.S. Jones in the 1999 NASA/ASEE Summer Faculty Fellowship program showed that local air density and flow Mach number affect the performance of actuators. The experiments revealed significant changes in the resonant frequencies of one actuator with changes in the static pressure and density of the air in which it was operating. Furthermore, the actuator effects upon an attached boundary layer flow were unexpectedly limited for the low pressure, Mach 0.4 conditions examined in the most detail.

In this year's program, research was conducted to determine changes in the resonant frequencies of actuators with changes in air density and pressure and to evaluate accompanying changes in actuator performance. Measurements of the axial profile of the synthetic jet velocity were used as a simple diagnostic measure of actuator performance. Measures of actuator performance more representative of flow control effectiveness were achieved through measurements of actuator-induced changes in boundary layer mean and fluctuating profiles. The actuator discharged normal to the wall at the bottom of the boundary layer. Experiments were conducted with two actuator configurations. Changes in actuator resonant frequency were determined from the spectra of microphones mounted in actuator walls and hot wire anemometer probes positioned at the aperture exit. Changes in resonance were measured at air densities corresponding to pressures ranging from 0.046 to 1 atmosphere. The varying densities were achieved by operating the actuators in the Probe Calibration Tunnel. These measurements were complemented by hot wire anemometer surveys of the axial profile of the synthetic jets. The hot wire probes were calibrated in this tunnel at the test densities, with the most comprehensive measurements at densities corresponding to pressures of 0.263, 0.526, and 1 atmosphere. The effects of the actuators on boundary layer flows were measured for these pressures at Mach numbers of 0.1 and 0.2, with limited measurements at other Mach numbers. The experiments showed that operating density has a large effect upon actuator performance. The largest synthetic jet velocities were found at the lowest density conditions. The greatest effectiveness in altering boundary layers was found at the lowest densities and Mach numbers. Increasing density had moderate effects in reducing the synthetic jet velocities, but strong effects in reducing boundary layer control effectiveness. Efforts to scale these effects with acoustic impedance, air density, velocity, and synthetic jet momentum flux are underway.

A Computational Investigation of Approximation Techniques for Engineering Design Optimization

**William A. Crossley, Ph. D.
Purdue University
School of Aeronautics and Astronautics
West Lafayette, IN 47907-1282
e-mail: crossley@ecn.purdue.edu**

Approximation techniques, particularly the use of response surfaces (RS), have achieved wide popularity in engineering design optimization, especially for problems with computationally expensive analyses. The chief aims of using RS is to lower the cost of optimization and to smooth out the problem (e.g., for analyses solved iteratively, with a convergence tolerance).

The use of RS raises practical questions about the solution accuracy and computational expense. In particular, building response surfaces may involve a prohibitively large number of high-fidelity function evaluations, depending on problem dimensionality. We conduct a computational study to address these two questions.

The first part of the study compares solutions obtained with a number of RS in a variety of optimization procedures. Specifically, results obtained in typical heuristic procedures that replace the direct use of high-fidelity analyses in the optimization with RS are compared to results obtained in a systematic approximation/model management framework (AMMF) developed by the Multidisciplinary Optimization Branch at NASA Langley. The tests allow us to determine the guidelines for when the typical heuristic procedure may be sufficient and when not, in order to produce an accurate answer.

In the second part of the study, we compare a variety of optimization procedures used with RS approximations to optimization algorithms that use high-fidelity evaluations directly in combination with sensitivity-based techniques. This study allows us to draw a number of conclusions on the expense of the alternative procedures based on the problem dimensionality.

An airfoil design problem serves as a test problem for this study. The design variables are the y-location of eight spline control points used to represent the shape of the airfoil. The drag-to-lift ratio is minimized, subject to bound constraints, for two flow conditions. The Euler solver (inviscid) option of FUN2D is used as the high-fidelity analysis to provide values of lift and effects of compressibility (or wave) drag. A D-optimal design and a Face-Centered Central Composite Design (CCD-FC) are used as alternative designs of experiments for the construction of RS. The NACA 0012 airfoil and the Boeing 737's wing mid-span (transonic) section are used as two baseline shapes.

Higher-Order Methods for the Solution of the Poisson Equation in Parallel

**Ayodeji O. Demuren
Old Dominion University
Department of Mechanical Engineering
Norfolk, VA 23529
e-mail: demuren@mem.odu.edu**

Procedures are developed for the solution of the Poisson equation in multiple domains in parallel. Possible applications are the governing equation for temperature in heat transfer problems or pressure in incompressible Navier-Stokes equations. In order to guarantee stability, finite-difference schemes of arbitrarily high order which obey the summation-by-parts rule are utilized. If the Poisson equation is solved in parallel in each subdomain without a global scheme to couple all subdomains together there must be some overlap at subdomain interfaces for the schemes to be stable. The required overlap depends on the order of the finite-difference scheme, and there exists an optimum which minimizes the spectral radius of the iteration scheme and hence the global convergence rate. For 4th and 6th order schemes optimum interface overlap was found to be 3 and 5 grid points, respectively. A multigrid scheme was devised to couple the subdomains together globally. This removed the need for any interface overlap and ensured convergence in a few iterations. But communication between processors increased with a corresponding decrease in parallelization efficiency. An alternative approach used a domain-decomposition cyclic-reduction method to determine the interface solution and thus decouple the subdomain solutions. For very large problems, both of these methods are more efficient overall than the overlap method without global communication.

High Power Rocket Demonstrator of a Reusable Glideback Booster

Dianne J. DeTurrís, Ph.D.
Aerospace Engineering Department
Cal Poly State University
San Luis Obispo, CA 93407
e-mail: ddeturri@calpoly.edu

The Cal Poly Space Systems Club has built a series of high power rockets which explore the concept of remotely controlled, fixed wing, flyable booster rockets. The goal is to reduce costs for getting payloads into orbit by using a completely reusable first stage booster with very short turn around times. The rocket demonstrators have a conventional vertical launch, then as the rocket begins its descent after apogee, an R/C control system is used to fly the rocket as a glider to a controlled landing. The subsonic, canard and delta wing configurations that were built grew progressively in size to almost 10-ft tall. A 5-ft tall model under R/C control was successfully glided for over 30 seconds. A 9.5-ft tall model also flew once but produced no gliding flight.

An analysis of the flight data has determined that the configuration will fly a more controlled glide path with an all moving canard. Wing loading and center of gravity location during transition from launch to glideback also significantly affect the flight path. An M-1419 solid motor will enable the 65 lb. rocket to attain an altitude of 3500 ft, enabling a longer glide. Flight instrumentation and telemetry are being added to the rocket for use in performance verifications of the full-scale booster.

A Universal Model for Predicting Gaseous and Particulate Emissions from Biomass Burning

George S. Devendorf
Middle Tennessee State University
Department of Chemistry
Murfreesboro, TN 37132
gdevendo@mtsu.edu

Gaseous and particulate emissions from vegetation fires introduce significant amounts of CO₂, CO, particulates and a number of other chemically important trace gases into the atmosphere, impacting local and global atmospheric chemistry and meteorology. Satellite detection has been the primary means by which fires have been detected and monitored on a global scale, and a new satellite, FIRESAT, has been proposed whose orbit, resolution and detection channels are optimized for the sole purpose of fire detection. In conjunction with the development of FIRESAT, a predictive model for quantifying the relative amounts of gaseous and particulate emissions has been developed which will utilize the temperature measurements of FIRESAT to estimate emissions from detected fires.

While the spectrum of emitted compounds is relatively constant and well established, the relative amounts (emission ratios) can vary depending on the type of fuel (ecosystem), and a host of other variables which affect the mix of flaming and smoldering combustion taking place within a given fire. Quantifying fire emissions has usually proceeded using sets of average emission ratios for each ecosystem or fuel type determined by measurements from previous fires. Even within a single ecosystem however, emission ratios from individual fires can regularly vary from the best average values by as much as $\pm 50\%$ because of the different degrees of flaming and smoldering combustion within the fire. The combustion efficiency (CE), defined as the emitted CO₂ divided by the sum of emitted CO₂ and CO, is a convenient measure of the mix of flaming and smoldering combustion, and scales with the temperature of the fire. Using this single parameter and a set of baseline emission ratios, a predictive model has been developed which not only predicts the variation in emission ratios within a single ecosystem, but successively predicts measured emission ratios across all the various forest, scrub and grassland ecosystems for which measured emission ratios are available. Variations between measured ecosystem specific emission ratios and universal predictions are less than 15% of the measured emission ratio, and though this variation may be due in part to specific ecosystem fuel factors, the 15% difference is well within the error range of most average values utilized to calculate fire emissions.

The success of this single universal model suggests that the observed variations in emission ratios are due primarily to the different combustion efficiencies of fires, and that outside of shaping combustion efficiencies, differences in fuel between different ecosystems play only a minor role in determining emission ratios. (Ecosystem specific trends may be built into the model's baseline emission ratios, which vary slightly with CE.). More importantly, the model's singular dependence on CE makes it a powerful and convenient predictive tool which can be used in conjunction with the temperature measurement's of FIRESAT, as well as other fire and emission modeling work.

2000 NASA-ASEE SUMMER FACULTY FELLOWSHIP

Final Report

Dr. Amin N. Dharamsi
Department of Electrical and Computer Engineering
Old Dominion University, Norfolk, VA 23529-0246

INVESTIGATION OF AN EYE-SAFE LIDAR FOR CARBON-DIOXIDE MEASUREMENTS

Carbon dioxide is an important constituent of the atmosphere whose concentration and distribution play a significant role in the carbon cycle and thermal budget of the earth. The concentration of this constituent of the atmosphere has been studied for many years with conventional balloon and rocket sounding techniques as well as by grab sample techniques. In addition to discernable long-term trends in concentration, there are seasonal changes that have been recorded.

This project involved a preliminary study of the feasibility of pursuing the development of an eye-safe solid-state laser operating in the $2\ \mu\text{m}$ region where there are several vibrational-rotational lines in the CO_2 spectrum. A survey of all the absorption lines in this region, accessible to the Ho:Tm:YLF laser systems currently available in the Laser Systems Branch, was performed. The transitions examined were in the third component of the Fermi triad, namely the component $(00^0_0)_I \rightarrow (20^0_1)_{III}$. This triad results from Fermi Resonance between the 20^0_1 , the 12^0_1 and the 04^0_1 vibrational manifolds.

Several rotational lines in both the P and R branches were examined. While the choice of suitable lines of CO_2 is complicated somewhat by the presences of a large number of lines due to water vapor in the same spectral region, the fact that the temperature dependence of these two species is dramatically different is a mitigating factor that can be turned into an advantage in retrieval algorithms. Calculations of the transmission of light in these regions of the spectrum were made for several temperatures. These effects of temperature on both the P and R branches of CO_2 were studied. In addition, the variation in absorbance with temperature of the many water vapor lines in the same spectral regions was also studied.

A simple model to estimate the expected LIDAR return signal for at these various wavelengths has been developed and it is expected that the model will be refined in future studies so that an assessment of the precision of the measurement that can be performed by the current $2\ \mu\text{m}$ laser developed at NASA LaRC can be made.

The preliminary results obtained in this short study show that the effort to pursue such measurements by using Differential Absorption LIDAR (DIAL) using an injection seeded, line-center stabilized, Ho:Tm:YLF Laser is a promising undertaking.

A Real-world Scenario-based Learning Framework for Distributed Collaborative Engineering

David A. Dryer

NASA LaRC ASEE Summer Faculty Fellow-2000

College of Engineering and Technology

Old Dominion University, Norfolk, VA, USA

Abstract

Training and experience in distributed virtual collaborative engineering are becoming more and more important as the use of advanced communication and information technologies transform engineering organizations. At NASA, this transformation is being led by the Intelligent Synthesis Environment (ISE) initiative. ISE is a national initiative aimed at making substantial progress toward fulfilling the NASA Administrator's vision for revolutionizing next generation science and engineering capabilities.

This initiative will achieve this vision by developing revolutionary ISE-related technologies, engineering practices and coordinating related on-going NASA activities, industry activities, other government agency initiatives and university research. To prepare engineers for this new reality, a real-world scenario-based learning framework is being developed to introduce engineering practitioners to distributed collaborative engineering and help achieve the organizational "buy-in" for such a revolutionary transformation. Critical characteristics of this framework involve engaging content, course delivery, structured learning, and university synchronization. ISE-related success stories and lessons learned, both internal and external to NASA, are used to help set the stage for learning and applying ISE. The learning framework is based on a real-world NASA large-scale application (LSA) project scenario storyline and selected project use cases. This enables participants to understand ISE benefits for various project tasks and apply appropriate ISE tools to selected tasks.

Course delivery is primarily web-based with synchronous and asynchronous modes to allow easy access. Content is more easily updated through planned integration with an ISE knowledge repository. Learning is further structured through defined learning objectives, embedded assessment, and feedback from facilitators and other participants. NASA's organizational collaborative engineering learning framework is further enhanced through synchronization with other external initiatives. One such initiative is occurring at Old Dominion University (ODU). ODU's College of Engineering and Technology (COET) is beginning a transformation to a college of enhanced engineering or "E-engineering" using real-world project scenarios and distributed collaboration tools across the curriculum. The pilot course for this initiative is a multidisciplinary freshman engineering and technology course, which is developing immersive engineering input device prototypes for NASA ISE. This will introduce incoming students to the necessary skills and practices in the latest methodologies and technologies to apply in virtual collaborative engineering environments.

Hamiltonian Formulations and Conservation Laws for Fluid Flow

**Mark Farris
Midwestern State University
Department of Mathematics
Wichita Falls, TX 76308
farris@nexus.mwsu.edu**

Acoustic conservation laws can be useful to check the validity of numerical solution schemes. Systems of equations that can be formulated as a Hamiltonian system are subject to the Hamiltonian version of Noether's Theorem. Briefly stated, any conserved quantity is associated to a symmetry of the Hamiltonian system. This report gives Hamiltonian representations of the equations for fluid flow for an inviscous fluid for both isentropic and adiabatic flows. Then the technique for searching for conserved quantities is illustrated. In one space dimension there is an infinite family of conservation laws similar to the situation for the Korteweg-DeVries equation. In three space dimensions the situation is not so rich. However, the analysis here leads to an understanding of the exact energy law found by Myers[1]. A slight generalization of Myers' result is given.

1. MYERS, M.K. 1991 Transport of energy by disturbances in arbitrary steady flows. *J Fluid Mech.* **226**, 383-400.

Aerodynamic Evaluation of Tip Mounted Jet Nacelles

Thomas A. Gally, Ph.D.
Embry-Riddle Aeronautical University
Aerospace Engineering Department
Prescott, AZ 86301
e-mail: gallyt@pr.erau.edu

A computational investigation into the aerodynamic effects of a wing tip mounted jet nacelle was undertaken in order to verify and expand upon information gained in previous experimental studies. In those experimental studies, the presence of a powered turbo-fan on the wing tip indicated the potential for significant performance gains through induced drag reduction and improved flight operation safety through the reduction in the strength of the trailing wake vortex system. This computational study seeks to quantify the performance gains into a form usable for preliminary design studies and to increase the level of understanding of the flow mechanisms involved.

Results obtained using both an inviscid CFD analysis and a simple vortex lattice model are similar to the performance gains seen in the experiment work. The source of these gains can be attributed to the redistribution of the wing tip vortex over the radial surface of the nacelle. As such, this effect is dependent upon the relative engine nacelle size, but largely independent of the mass flow through the engine and, thus, the engine power setting.

The trailing wake vortex system is also favorably effected by the presence of a wing tip nacelle. For a simple flow-through nacelle, the vortex strength and the rate of vortex roll up appear to be reduced due to the redistributed and dispersed wing tip vortex. When air is forced through the nacelle, further reduction of the vortex strength is seen via the shearing action between the nacelle exhaust and ambient airflow. The greater the velocity difference between nacelle and ambient flow, the greater is this shearing dispersion of the vortex energy.

It may also be possible to induce an early bursting of the wing tip vortex by forcing air through the nacelle and thus through the core of the wing tip vortex. Such vortex bursting would greatly reduce the trailing vortex strength and, if it occurs close enough behind the wing, may provide an additional performance benefit. Some evidence of this vortex bursting was seen in the computational results, however, additional work to build confidence in the computational modeling needs to be done before strong conclusions can be made.

Utilizing NASA Computer Technology to Solve Large-Scale Problems for the U.S. Auto Industry

**Myron Ginsberg, Ph.D.
HPC Research and Education
Farmington Hills, MI 48335-1222
e-mail: m.ginsberg@ieee.org**

There are very large-scale, numeric-intensive automotive applications which at present are intractable on conventional serial computers because the needed computational execution time and/or I/O and memory requirements are much too large to be economically viable in a commercial industrial environment. Furthermore, the global competitiveness of U.S. auto companies requires ever decreasing lead times between concept and product production. Thus physical prototyping must be increasingly replaced by fast, accurate, and realistic computer simulations; in 1980, lead-time was 60 months and at present it is 24 months with a target of 18 months. Meeting such a goal requires effective and aggressive use of parallel computing hardware, software, and algorithm technologies.

This summer investigation focuses on identifying and documenting many of the large-scale automotive applications as well as their computational bottlenecks. Prior to the beginning of this project, presentations were given at General Motors, Ford, and DaimlerChrysler sites to solicit candidate problems and a questionnaire has been distributed to gather information about each application. The results from this project will be used for follow up performance improvement investigations. This work will help to identify how to utilize innovative parallel computing technology strategies to improve U.S. global automotive competitiveness. Representative applications submitted include: transient analysis of a V6 exhaust manifold using a coupled 1D/3D model; solution of normal modes for models with 100,000 to 500,000 grids, approximately 600,000 to 3,000,000 DOF; simulation of vehicle impact in real-world crashes; establishing statistical characteristics of vehicle road noise performance using the Monte Carlo simulation method; full vehicle external flow simulation for a production vehicle; stochastic multidisciplinary shape optimization of crash and NVH.

A compendium of relevant websites has been compiled to document useful performance information and resources related to this project. Also, the bottlenecks to automotive industry use of leading-edge high-performance computing technology are identified along with recommendations on how to overcome these barriers. Since the automotive companies are dependent on the use of commercial independent software vendor (ISVs) codes, an attempt has been made to promote tech transfer of innovative algorithms and methodology from government research codes to the ISV-based industry software. In addition, several presentations were given on high-performance computing hardware, software, and algorithm issues.

Velocity Filtered Density Function for Large Eddy Simulation of Turbulent Flows

Peyman Givi

Department of Mechanical and Aerospace Engineering
State University of New York at Buffalo
Buffalo, NY 14260-4400

Abstract

The “velocity filtered density function” (VFDF) methodology, developed in my ASEE visit in 1999 was implemented this year for large eddy simulation of several turbulent flows. In this methodology, the effects of the unresolved subgrid scales (SGS) are taken into account by considering the joint probability density function (PDF) of three components of the velocity vector. An exact transport equation is derived for the VFDF in which the effects of the SGS convection is shown to appear in a closed form. The unclosed terms are modeled in a manner analogous to “conventional” second order closures. A system of stochastic differential equations (SDE’s) which yield statistically equivalent results to the modeled VFDF transport equation is proposed, and is solved via a Lagrangian Monte Carlo scheme. The consistency and the convergence of the equivalent SDE’s are assessed by comparison with results obtained by “conventional” LES in which the corresponding transport equations for second order SGS moments are solved. The performance of the VFDF is assessed via *a posteriori* comparisons with direct numerical simulation (DNS) data of a three-dimensional temporal shear layer, after *a priori* evaluation of the VFDF closure coefficients. Work is under way to compare the numerical results with experimental data.

*** Patch Network for Power Allocation and Distribution in Smart Materials**

**Dr. Walter T. Golembiewski, Ed.D.
Norfolk State University
Dept. of Technology
Norfolk, VA 23504
wtgolembiewski@nsu.edu**

The power allocation and distribution (PAD) circuitry is capable of allocating and distributing a single or multiple sources of power over multi-elements of a power user grid system. The purpose of this invention is to allocate and distribute power that is collected by individual patch rectennas to a region of specific power-user devices, such as actuators. The patch rectenna converts microwave power into DC power. Then this DC power is used to drive actuator devices. However, the power from patch rectennas is not sufficient to drive actuators unless all the collected power is effectively used to drive another group by allocation and distribution. The power allocation and distribution (PAD) circuitry solves the shortfall of power for devices in a large array. The PAD concept is based on the networked power control in which power collected over the whole array of rectennas is allocated to a sub domain where a group of devices is required to be activated for operation. Then the allocated power is distributed to individual element of power-devices in the sub domain according to a selected run-mode.

* Invention Disclosure of NASA Case No. LAR 16136-1-CU, entitled "Networked Array Circuitry For Power Allocation And Distribution (PAD)," grant NCCI-280

Some Signal Processing Challenges in the Geostationary Imaging Fourier Transform Spectrometer

Monson H. Hayes
Georgia Institute of Technology
Atlanta, GA 30332

A Geostationary Imaging Fourier Transform Spectrometer (GIFTS) is being developed to enable the gathering of high spatial and high spectral resolution Earth infrared radiance spectra for enhanced meteorological observations and forecasting. The GIFTS measurement system consists of a pair of large area format focal plane detector arrays (128 x 128) in a Fourier transform spectrometer (FTS) that is to be mounted on a geostationary satellite. One of the signal processing challenges in GIFTS is to reduce the massive data rate (2.4×10^9 bps) in the interferograms to an affordable telemetry rate of less than 60 Mbps without any information loss. Just as one finds in CD players, the GIFTS interferograms are heavily oversampled to reduce the quantization noise in the A-D conversion process. Therefore, the first step in reducing the data rate is to decimate (downsample) the interferograms with minimal distortion while keeping the signal processing algorithms simple enough to be implemented in the GIFTS hardware. Once the interferograms have been downsampled, the next step is to compress the data with a lossless encoder. In this talk, we will begin with an overview of GIFTS from a signal processing point of view. Then, we will describe the process of downsampling, and propose several approaches that may be appropriate for the GIFTS hardware. Finally, we will describe some interesting research problems in the area of lossless and lossy interferogram data compression.

ABSTRACT NOT AVAILABLE AT REPORTING TIME

Dr. Jagannathan V. Iyengar
Department of Management and Marketing
University of Nebraska-Kearney
Kearney, NE 68849-4430
JIYENGAR@JUNO.com

Geographic Information Systems (GIS) Used to Manage an Online Facilities Master Plan
Portfolio at NASA Langley Research Center

Christopher B. Kerns M.A. Ed
Crownpoint Institute of Technology
Applied Computer Department
Crownpoint, NM 87313
e-mail: chris@cit.cc.nm.us

The Geographic Information Systems (GIS) Department maintains computer hardware, software and data used to geographically reference facilities at the NASA Langley Research Center (LaRC). GIS technology is used to inventory the facilities at LaRC and assist such issues as planning, design, maintenance, repair and emergency response. The GIS system can be customized to suit many needs and the user interface can be simplified for those with little or no GIS experience. As an example of GIS use, the GIS team is developing a flood prediction tool to determine areas at LaRC and Langley Airforce Base (LAFB) which are at high risk for flooding. Subsequently, more efficient irrigation measures can be developed.

GIS data is stored on a Silicon Graphics (SGI) server and accessed through Environmental Systems Research Institute's (ESRI) GIS products: ArcView, ArcINFO, MapObjects, ArcIMS and others. Data includes complete aerial photography of the LaRC facility and LAFB; point, line and polygon data depicting buildings, utility lines, land use and historical sites (to name a few); and ESRI Web-based GIS products that enable a user to view the data through an Internet browser. The GIS database is continually evolving as more data is collected and existing data is subjected to greater measures of accuracy.

The Capital Investment Planning Office maintains a portfolio called the Facilities Master Plan (FMP). The portfolio serves,

"... to provide a narrative, statistical, and graphic record of land, buildings, and other facilities or improvements at Langley Research Center. It also provides a report on the installation's potential and planned development in keeping with current analysis and construction program plans."

The FMP is a printed portfolio that documents many features of LaRC such as history, traffic systems, architectural styles, landscaping, zoning, wetland determinations and geology. Though the FMP is comprehensive, it is a static snapshot of LaRC. Occasionally, the FMP is reviewed, revised and republished.

With the introduction of GIS technology at LaRC, the FMP can be converted to an on-line document that is constantly updated as changes are made in its related data sets. Thus, Langley's FMP claim of being a "Living Document" can be realized fully. The GIS team has begun the process of converting the FMP to an on-line document. Currently, the on-line version does not implement the expanded capabilities of Internet browsers and database queries. Though the bulk of the data is on-line, web design work can make it more user-friendly and interactive.

During the 10-week fellowship, Microsoft FrontPage 2000 was used as the Web page development application. Many of the web pages were enhanced with JavaScript and Applets were used to run server-side MapObjects and ArcViewIMS applications to serve maps and requested data. Dated images were recaptured with a digital camera and animations were added for aesthetic effect. Each page was redesigned to utilize web technology that makes web viewing more interactive and efficient.

Compressible Boundary Layer Receptivity of a Swept Wing due to Surface Roughness using Parabolized Stability Equations (PSE)

Frank P. Kozusko
Department of Mathematics
Hampton University
Hampton, Virginia 23668
e-mail: fpk@icase.edu

ABSTRACT

The process by which the boundary layer internalizes external disturbances in the form of instability waves is called boundary layer receptivity. The objective of this research is to study the roughness induced receptivity of compressible boundary layer flow over a swept wing surface. The roughness characteristics are based on measured data on a realized swept wing model. The methods of parabolized stability equations (PSE) and/or harmonic linearized Navier Stokes equations (HLNSE) will be used.

The linearized Navier-Stokes equations are derived by assuming the boundary layer disturbance to be small in amplitude in comparison with the unperturbed flow quantities. Neglecting nonlinear terms (in the disturbance) yields homogeneous PDEs with homogeneous boundary conditions which are spatially elliptic. These equations can be "parabolized" by assuming that the disturbance is in the form of a rapidly oscillating wave with a slowly varying shape function (Herbert, 1987). The PSE can be solved with the more efficient and less time consuming "marching method".

The introduction of roughness produces inhomogeneous surface conditions. A homogeneous computational surface can be achieved by a conformal coordinate transformation, yielding inhomogeneous PSE with a surface roughness forcing function. The inhomogeneous PSE are solved for the instability wave amplitudes using the adjoint and marching methods. The dependence of instability wave amplitude on roughness characteristics for both deterministic and stochastic surface geometries will be investigated.

General Aviation Simulator (GAS) Baseline Study for Advanced Weather Information Display Program

Mark D. Lee, Ph.D.
Old Dominion University
757-683-4222
mlee@odu.edu

The Advanced Weather Information (AWIN) program has a goal of reducing General Aviation (GA) accidents due to weather by fifty percent. To help achieve this goal the Operator Support Team (OST) within the NASA Langley Crew Vehicle Integration Branch (CVIB) has a research plan to examine the introduction of new weather displays into the GA cockpit. NASA maintains a General Aviation Simulator (GAS), that although inoperative for several years, is being brought on-line to support the AWIN program. Several studies were conducted to understand the baseline characteristics of the simulator. The goal was to develop a baseline AWIN simulation scenario, document the characteristics of the simulator, and to run some baseline human performance tests under weather conditions that vary from Visual Flight Rules (VFR) to Instrument Flight Rules (IFR). First, the simulator user interface was documented from the perspective of the pilot user and the simulator operator (real-time console user). The simulator was modified in many ways, and the Simulation Modification Requests (SMRs) are documented (see report). The flight qualities of the simulator were examined in two separate studies. In the first study, a simple check ride procedure was used to examine flight qualities under visual and instrument flight conditions. Several recommendations were provided by the pilot for improving the simulation. In the second study, a subset of the flight model parameters were adjusted across three sessions to help make the handling qualities of the aircraft more representative of a GA aircraft. In a third study a pilot with a visual flight rating was tested in a scenario that included a transitions between VFR weather conditions and IFR weather conditions. The set of experimental procedures, forms, weather stimuli, and simulator data file outputs were defined and documented. The pilots decision making process was assessed using post mission interviews and subjective workload ratings were collected using the NASA Task Load Index (TLX). The results of this first run are still being analyzed, but the preliminary analysis indicates that the weather scenarios will be effective. Issues associated with the use of the current GA simulator (e.g. the reduced field of view relative to actual flight in GA aircraft) were identified and documented for the AWIN program. In addition, avenues for further research and improvements to the simulator were identified and documented.

A Risk-Based Method for Evaluating NASA Technology for the National Airspace System

2000 NASA-ASEE Summer Faculty Fellowship – Project Report Abstract
NASA Langley Research Center: ASCAC/SAB
Garrick E. Louis¹, Vicki K. Crisp²

Garrick E. Louis
University of Virginia
Systems Engineering Dept.
151 Engineers Way, Charlottesville VA 22904-4747
louis@virginia.edu

The Aviation Safety Program at NASA has traditionally relied on accident data to assess the safety benefits of its technology in the National Airspace System (NAS). The approach compared the rates of occurrence of relevant types of accidents before and after the technology was introduced. The decrease was the measure of the contribution of the technology to improved safety in the NAS. This method has two major limitations. Firstly, it restricts the focus of analysis to accidents or symptoms rather than the related incidents or root causes that are precursors to aviation accidents. Thus, the agency loses the opportunity to evaluate technologies based on the entire system on which they have an effect. Secondly, the primary reliance on accident data, forces the technology evaluation and decision-making to be reactionary, as they depend on changes in the historical accident rates. Such an approach is of little use when deciding about investments in new, emerging technologies. A risk-based approach examines the set of incidents and processes in the system of NAS operations where aviation accidents occur. In this context, risk is defined as the product of the conditional probability of an accident (given a related set of incidents) and the severity or consequence of the accident measured in constant dollars. The probabilities are derived from annual data supplied by the NASA-Aviation Safety Reporting System (ASRS) and the National Transportation Safety Board (NTSB). These are modeled with a Poisson probability distribution. The consequences are derived from damage payments for aviation accidents derived from reports by the Department of Transportation and information on insurance claims paid. NASA's Synthetic Vision System (SVS) was used as a case study technology. Its effects on NAS operations related to commuter aircraft carriers were simulated using a Markov state-based model. The outputs of this modeling and simulation were the changes in the frequency and types of incidents and accidents as well as changes in the consequences of these accidents. Thus, the effect of synthetic vision on risk in the NAS could be determined as the difference between the risk computed prior to and following introduction of the technology. Sensitivity analysis is conducted to determine the variables with the greatest impact on risk and to set uncertainty bounds for the results. The method provides the agency with predictive power to evaluate emerging technologies for the NAS based on their expected impact on risk. Furthermore, it establishes a standard unit for risk measurements based on dollar value, which permits comparisons across technologies and across areas of operation in the NAS. The development of this risk-based approach to technology evaluation gives the Systems Analysis Branch an early start in complying with the requests of NASA Administrator, Dan Goldin, to incorporate probabilistic risk assessment as a tool to improve the safety performance of the agency.

¹ University of Virginia, Department of Systems Engineering

² NASA-Langley Research Center, Aviation Systems Concepts and Analysis Competency: Systems Analysis Branch

Single Frequency Er:Yb Co-doped Fiber Optic Laser for Fiber Sensor Applications

Patricia F. Mead, Ph.D.
Mechanical Engineering Department
University of Maryland
College Park, MD 20742
e-mail: ashaki@eng.umd.edu

Single frequency operation of Er^{3+} -doped and $\text{Er}^{3+}:\text{Yb}^{3+}$ -codoped fiber optics lasers have been documented in the literature for several years. These lasers are favorable for fiber based optical communications systems and fiber sensing applications because of their emission near $1.5\mu\text{m}$. They also offer attractive size and weight advantages for complex optical system applications. These lasers can also be made tunable by several techniques including mechanical or temperature tuning of in-fiber Bragg grating reflectors, tuning of the fiber gain spectra through temperature effects, manipulating the fiber refractive index (or birefringence) by the strain- or thermo-optic effects, or by incorporating other tunable components inside the laser cavity (e.g. fiber Fabry-Perot (FFP) filters or bulk grating components). Finally, injection seeding the laser to obtain a selected wavelength is yet another possibility. Commercially available fiber optic lasers are only recently becoming available. However, these units are prohibitively expensive and often do not have the desired flexibility for incorporation into compact, flight qualified detection systems. The objective of this research has been to demonstrate a basic approach for achieving continuous, single frequency output of a fiber optic laser, using a compact and rugged configuration. The laser should also be tunable over several tens of nanometers.

We have selected a simple linear configuration cavity, with tunable Bragg grating mirrors. The laser cavity will be sufficiently short to achieve single frequency operation for low pump power excitation. A diode laser pump source is used to meet size and ruggedness objectives. The erbium material system has been chosen because of the compatibility with existing NASA fiber sensor activities. Also, ytterbium codoping in erbium fiber lasers is known eliminate self-pulsing behavior, resulting in a stable laser output, and at higher power efficiency. Finally, the tuning range of the laser is limited by the tuning range of the Bragg grating mirrors of the laser cavity. Demonstration of the bench top laser system will require careful attention to Bragg mirror fabrication, and some attention to the mechanical characteristics and reliability of spliced and recoated fibers is also needed. The long term development of this laser will also require suitable methods for cavity stabilization (frequency stabilization), wavelength selection (tuning control), polarization control, and intensity noise characteristics. A proposed arrangement to meet these objectives will be included in the final project report. The approach includes electronic feedback control to stabilize the laser wavelength via a piezoelectric tuning of the Bragg grating mirrors, and intensity modulation feedback to the diode pump.

NASA AND A SECOND-GENERATION SUPERSONIC TRANSPORT

Anne Millbrooke

Northwest Campus, University of Alaska Fairbanks

History Department, Pouch 400, Nome, AK 99762 • nfam@uaf.edu • 907-443-2201

On Tuesday 25 July 2000 a Concorde crashed after takeoff from the Charles de Gualle airport in Paris. All 109 people on board and 4 people on the ground died. This was the first crash of a supersonic transport in commercial operation. Reuters news service announced that the “Crash Casts Gloom on European Aviation Industry.” The BBC concluded that the crash was the “end a French national symbol.” *Time Europe* asked, “Will the tragedy cloud the future of supersonic flight?” A British-French consortium made the Concorde, and the Tupolev design bureau in the Soviet Union made the supersonic Tu-144 transport, both of which entered production and service in the mid 1970s. Despite decades of supersonic research and development in the United States, the United States has never built a supersonic transport. NASA’s High Speed Research Program was the agency’s “top priority” of the 1990s, yet in 1999 the United States stopped development of a second-generation supersonic transport. Why?

In the 1940s the National Advisory Committee on Aeronautics (NACA) conducted dive-flight research, dropped airplane models from airplanes, fired small solid-propellant rockets, and experimented with rocket-propelled aircraft to explore the speed limits of flight. The research plane became the research tool of choice for studying supersonic flight in the late '40s and early '50s. The military services sponsored the development of the research planes, contractors built the planes, and the NACA served as research coordinator. These parties developed and tested specialized aerodynamic research airplanes, the first of which was the Bell X-1. Air Force Captain Chuck Yeager flew the X-1 faster than the speed of sound on 14 October 1947.

By the late 1950s NACA had developed, constructed and placed into operation high-speed wind tunnels and initiated research into supersonic cruise technology. This research continued under NACA's successor — NASA. In 1960 NASA established a Supersonic Transport (SST) research program. The United States canceled its SST program in 1971 because of environmental and economic concerns, while the British-French team produced the Concorde, and the Soviet Union the Tupolev Tu-144. After the SST program, NASA maintained a core competency and continued research in the supersonic field.

In the mid 1980s NASA began to explore the feasibility of a second-generation supersonic High Speed Civil Transport (HSCT), and in 1990 the agency began a High Speed Research Program (HSRP) to develop the technology foundation for such an aircraft. The research involved enabling propulsion materials, critical propulsion components, aerodynamic performance, airframe materials and structures, flight deck systems, technology integration, and environmental impact. Overall, the High Speed Research Program produced impressive results, notably computer models, composite materials, and synthetic vision, but the program closed in 1999. This time the core competency went with the program, as the engineers and scientists dispersed to other jobs on other projects inside and outside of NASA. The aircraft under consideration was neither environmentally acceptable nor economically viable, and, given the changing world market and increasingly restrictive environmental standards, there was no promise of near-term solution of the economic and environmental problems.

Optical and Thermal Radiative Analysis of the CERES instrument using Monte-Carlo Ray-Trace Method

Félix J. Nevárez
Polytechnic University Of Puerto Rico
Dept. of Electrical Engineering
Hato Rey, PR 00919
e-mail: fnevarez@pupr.edu

For the last year the Thermal Radiation Group at Virginia Tech has been developing an environment based on the Monte-Carlo Ray-Trace Method to model thermal and optical systems called FELIX (Fundamental Environment for Longwave Infrared eXchange). FELIX allow researchers to model different cavities by incorporating an existing CAD drawing and assigning surface properties for a specific wavelength. A ray-trace engine is used to calculate the distribution factors, which is the amount of energy leaving element i that is absorbed by the element j directly or due to all reflections (diffuse or specular). This three dimensional graphical environment was used to model the energy exchange between surfaces inside the CERES (Clouds and Earth's Radiant Energy System) telescope cavity. CERES is a Earth Radiation Budget radiometer developed by NASA to measure radiative energy balance on the earth due to solar reflected and earth emitted radiation at the top of the atmosphere. This is accomplished by doing measurements in three spectral bands, the long wave channel, window channel and the total channel

NASA is currently working on the next-generation instruments to follow up the CERES project. One idea under consideration is to modify the current instrument so more spectral channels can be added without significantly changing the optical point spread function, which is the detector's response to collimated energy arriving to the cavity as a function of the incident angle. Two different telescope configurations were modeled, a modified Cassegrain with primary and secondary spherical mirrors and a Ritchie-Chretien Cassegrain that uses hyperbolic mirrors. Both configurations were modeled inside the current geometry with no modifications on the telescope cavity and also were modeled on a modified version to fit slightly bigger aperture mirrors to study the effect on the throughput to the detector. The field stop was removed from the cavity to calculate the 90% cover area available to fit the detectors. The off-axis aberrations at the detector due to collimated radiation arriving at an angle were studied.

Efficient Sparse Assembling/Equation-Eigen Solvers For Finite
ElementAcoustics/CFD/Structures/Electromagnetics
Engineering Applications

Duc T. Nguyen
Old Dominion University
Multi-disciplinary Parallel-Vector
Computation (MPVC) Center
135 KAUF
Norfolk, VA 23529

Efficient algorithms for sparse assembling, equation and eigen-solvers for finite element acoustics/cfd/structures/electromagnetics engineering applications are explained. Both real and complex numbers can be treated. Both small-scale numerical results (for algorithms and/or computer coding validation), and “preliminary” results for “large-scale” problems are reported.

Future algorithms and computer software developments to address the needs for NASA researchers (in acoustics, electromagnetics, cfd, structures etc...) and Independent Software Vendors (ISV) are also discussed.

NASA LIVE: Using Videoconferencing as the Basis of a New Program in Distance Learning for the Langley Research Center Office of Education

Professor William Nichols
Math-Science-Computers Division
Blackfeet Community College
Browning, Montana 59417
406-338-5411, ext 254

The NASA Langley Office of Education has a long history of promoting and developing outreach programs for students, teachers, and the public. It has generated award winning successes like the NASA WHY FILES, NASA CONNECT, Destination Tomorrow, and NASA's KSNM TV programs. It sponsors a variety of workshops for pre-service and in-service teachers, and secondary school students. The LaRC Office of Education sponsors summer research internships for college faculty, ASEE, and undergraduate students, LARSS. While some of these projects promote math and science education topics to elementary and middle school audiences, other projects involve on-site experiences in research, and teaching strategies. Videos, curriculum aids, and web-based activities add to the legacy of educational outreach of the NASA Langley Office of Education. However, gaps exist in the coverage of high school and college audiences, and in the dissemination of knowledge obtained from the cutting edge research done by NASA scientists and technicians. A new program, NASA LIVE, bridges these gaps.

The mission of the LIVE program is to facilitate the dialogue and transfer of knowledge from NASA researchers to colleagues, and to grades 10-18 educators and students, at distant sites. The goal of the LIVE program is to help NASA scientists share with the educational community, in a collegial and technologically versatile manner, the knowledge they have gained from exploration and discovery.

The NASA LIVE program embraces a new dimension of educational outreach. The LIVE program provides a forum that NASA scientists can use to share the results of their research in an educational setting. The LIVE program links NASA presenters with high school students and teachers, university students at all levels and their faculty, and colleagues from professional organizations in an interactive, multimedia format. NASA researchers can prepare several topics that they can disseminate to a variety of audiences at distant sites from the comfort of the electronic classroom in the Office of Education.

The LIVE program uses videoconferencing technologies to bring the NASA scientist and the audience together. Using these technologies save on time and travel, and still provide for a great deal of flexibility in the delivery of the presentation. The LIVE program makes use of dial-up audio-video technologies that are deliverable over T-1 connections. This provides for the bandwidth that is needed to display a wide variety of multimedia formats in conjunction with two-way audio and video. The technology was proven in a series of videoconferencing experiences.

Thirty NASA researchers were recruited as potential presenters; fifteen of them indicated their interest in the program, and nine attended an orientation session. Faculty at forty-five colleges and universities were approached about the possibility of their participation as potential audiences. Ten colleges have agreed to participate so far.

Conductive Ceramic Coatings on Silica

Dr. Ronald J. Pollock, Ph.D.
Assistant Professor of Chemistry
Pennsylvania State University
Sharon PA 16146
Email: rjp4@psu.edu. Office phone: (724) 983-2962

Ceramic models made from silica that are aerodynamically tested in wind tunnels are often coated with materials that respond to airflow, heat, and pressure. Some of these sensing materials are powder coatings. Powder coatings are sprayed onto a conducting material that is charged with a DC current. The charge attracts the coating and forms a stronger layer that cannot be achieved by conventional spraying. Ceramic models of silica are nonconducting and must have a conductive layer applied before powder coating. Currently, this conductive layer is formed by dissolving aluminum powder in sulfuric acid, forming soluble aluminic acid, and spraying this mixture onto the ceramic model. This provides a conductive layer of aluminum. It is then possible to apply a powdered coating. There are problems that arise when using aluminum. The most serious problem is that a metal conducts both heat and electricity. This will broaden and diffuse heat flux readings for the model. Less serious problems are that the aluminum may not bond well to the ceramic surface; dyes, phosphors, and other materials do not bond well to the aluminum; and the aluminum coating process is labor intensive.

A better coating was proposed and developed to resolve the major problem with aluminum. The indium tin oxide material, ITO, is an electrically conducting but not a thermally conducting material and was used to coat the silica model. Other problems are also reduced. The ITO forms a stronger and more adhesive layer with the model, because ITO and the model are both ceramic materials. The ITO seals the porous silicon dioxide model and creates a stronger and smoother surface.

The test samples exhibited good adhesion and conductivity after thermal curing. The ITO coating is now being applied to an X-34 model to be aerodynamically tested in LaRC's 31-inch Mach 10 Tunnel.

Another coating material, antimony tin oxide ATO, is in the early stages of investigation. This material is also an electrically conducting but thermally nonconducting ceramic oxide. ITO is an expensive material and the use of ATO could reduce the purchase cost by seventy-five percent.

Elastic Tailoring of Aircraft Structures With Composites

**Lawrence W. Rehfield, Professor
Mechanical and Aeronautical Engineering
One Shields Avenue
University of California, Davis
Davis, California 95616
(530) 752-8100
e-mail: lwrehfield@ucdavis.edu**

A significant attribute of laminated composites is their design flexibility. The layers or plies of a laminate are, in fact, modular units which can be selected to provide distinct material properties and fiber orientations. It is possible, therefore, to "tailor" the properties of composites to meet specific design requirements. Engineers are learning to exploit this flexibility to produce unique structures tailored to the application.

Tailoring normally consists of selecting an appropriate structural concept, material systems, fiber orientations, ply stacking sequence, in an optimization approach to achieve specific performance goals. Common tailoring goals are preventing structural instabilities or vibration resonances or enhancing damage tolerance.

Tailoring is passive control of behavior. Desired behavior tendencies are designed into the structure as intrinsic qualities. The structure "wants" to emulate the desired behavior by virtue of the tailoring of the configuration. Use of this technology requires a thorough understanding of behavioral mechanisms and the parameters that control them. If the desired results cannot be achieved by passive means alone, active or extrinsic control technology may be used as well. Generally, tailoring the basic structure will reduce the level of active control required for the desired mission of an aircraft. Along with possible weight savings for the control system, simplicity and reliability may be achieved also.

The work completed this summer supports NASA's Aircraft Morphing Program. The purpose of this program is to develop active component technologies that enable self-adaptive flight for improved safety, affordability, environmental compatibility and performance. Structural tailoring may play a significant role in this effort.

Among the accomplishments of the summer are:

- (1) Closed form design analysis of laminated beams with bending-twist coupling;
- (2) Analysis of tailored box beams with bending-twist coupling;
- (3) Submitted an abstract to AIAA based upon (2).

Tailoring of bending-twist coupling has particular significances for subsonic wings and other lifting surfaces. The analyses serve as a basis for the design of experiments that are planned as future work in the Mechanics and Durability Branch for this program.

Finite Element Modeling of Synthetic Jet Actuators

Jeng-Jong Ro
Aerospace Engineering Department
Old Dominion University
Norfolk, VA 23529

Abstract

Interest in active flow control for aerospace applications such as wing flutter and tail buffeting, has stimulated the recent development of innovative actuator designs that create localized disturbances in a flowfield. A novel class of devices, known as synthetic jet actuator, has been demonstrated to exhibit promising flow control capabilities including separation control and thrust vectoring. The basic components of a synthetic jet actuator are a cavity and oscillating materials.

The synthetic jet actuator developed at NASA LaRC has a small housing in which a cylindrical cavity was enclosed by two metal diaphragms, 50 mm in diameter, placed opposite each other. A piezoelectric wafer was attached to the center of the outside face of each metal diaphragm. The pair of piezoelectric metal diaphragms was operated with a 180° phase differential at the same sinusoidal voltage and frequency. With actuation, a synthetic jet issued from a 35.5mm long by 0.5mm wide slot on the top of device.

In this study, a finite element model of the synthetic jet actuator tested at NASA LaRC is developed. The developed finite element model can be utilized to design and determine the performance of the synthetic jet actuator. The analysis is separated into two sections. The first section investigates the finite element model of the circular piezoelectric wafer. The non-conforming triangular plate element with 3 nodes per element is utilized to study the electric-structural coupling associated with the metal diaphragm and the input actuating voltage of PZT. The optimal geometry of PZT is found based on the maximum volumetric deflection of the circular piezoelectric wafer. The second section discusses the finite element modeling of the piezoelectric wafers with the fluid cavity system. The characteristics of the structural-fluid coupled system are investigated. The phase-average jet center velocity and amplitude of the input voltage of PZT are predicted by this finite element model. The theoretical prediction is compared to experimental results obtained at NASA LaRC.

Observations on NASA Sponsored Programs for In-service and Pre-service Teachers

George Rublein

College of William and Mary

Department of Mathematics

Williamsburg, VA 23187-8795

e-mail gtrubl@math.wm.edu

The author participated in three pre-service institutes and one in-service institute during the tenure of this ASEE fellowship. In the course of these presentations, a serious effort was made to demonstrate the usefulness of mathematical tools in the analysis of practical engineering problems. Particularly as the engineering agenda at NASA is aeronautics, as well as space science, our focus was primarily on aircraft flight and air navigation.

As a general matter, this approach seemed to find a positive response among the various members of the audience. Details of the evaluation of that response may be found in assessment reports available in the Office of Education.

A variety of 'field-trips' were arranged to demonstrate certain engineering facilities at the Center for the clients in these programs. These facilities, especially those of large scale, are bound to leave some sort of strong impression on viewers. However, it is the author's view that the entire ambience of Langley, and NASA more generally, could benefit from an organized and co-ordinated effort to demonstrate the practice of engineering to the audiences for these programs.

This emphasis has been emphasized in a recent major report by the National Research Council. The practice of engineering, including in a major way the use of mathematics, is a central ingredient in the work of Langley personnel. We believe that a careful study of many of the technical efforts made at Langley would show that, even for students at a relatively low level of mathematical training (circa algebra, co-ordinate geometry), that it is possible to provide all teaching personnel a *quantitative* look at science and engineering.

Such an approach is, in our view, crucial to the teachers' ability to convey the usefulness of mathematics and science to their young students. An often quoted truism tells us that teachers teach the way they are taught. If this truism, is, indeed true, then as long as teachers continue to teach mathematics as a subject that is mainly a classroom exercise, the US will continue to struggle with large segments of the population that are quantitatively impaired.

Active Control of Vibration without Computers

M. Roman Serbyn
Morgan State University
Dept. of Physics and Engineering Physics
Baltimore, MD 21251
e-mail: rserbyn@morgan.edu

The last two decades of the 20th century have seen a resurgence of interest in the use of active methods for controlling vibrations. Most of the techniques developed for military and commercial applications utilize sophisticated algorithms requiring substantial computer power as well as prior knowledge of the nature of the disturbance to be controlled. Accordingly, many of those schemes are limited to the cancellation of lines in a vibration spectrum, but are not very effective against random noise, especially if it is non-stationary.

My summer project had its origin some 20 years ago as part of an effort to counteract the effects of low-frequency vibrations on an optical interferometer system. Based on the information encoded in the output of the photodetector, a control signal is developed and fed to an actuator which in turn moves the 'fixed' mirror of the interferometer in a direction to oppose the disturbance. This process is repeated at a rate some thousand times higher than the significant frequencies in the disturbing signal. In effect, the controller generates a mirror image of the disturbance and applies it to the actuator. This control signal is built up from little positive- and negative-going ramps, which provides smoother control than a staircase function. In control-language terms, this is 'bang-bang' control whose requirement is to reduce the error in minimum time.

The components of the prototype system are 1980's type IC's (switches, multivibrators, logic devices, feedback amplifiers, etc.) operating on analog signals that had been converted to digital pulses. Because of its relevance to present-day applications, the system has been rebuilt using modern components with the consequent saving of space and cost. Eventually, it is planned to replace most of the newer IC's with their MEMS counterparts. Moreover, a redesign of the system using microprocessors is being considered. This task is suitable for a student project, and is motivated by the expectation that a microprocessor-based system may be cheaper than the already inexpensive IC-based system.

Regardless of the type of design, the control system just described has many potential applications. On closer examination it is possible to group these applications into two broad categories: position stabilization and vibration cancellation. Thus, the original application mentioned above had as its goal the maintenance of a fixed separation (optical path difference) rather than the control of vibrations that were causing it to vary. In a modification of this concept, the vibration of a surface is canceled out by a control signal developed in real time from the output of a vibration pickup. After successful replications of these baseline experiments, we plan to apply the same concept to the solution of other problems, specifically to the control of a zero-spring-rate mechanism and the reduction of vibrations of a non-rigid surface. For both applications we intend to use the MFC™ actuator recently developed by the NASA LaRC.

MIR S. SHIRVANI
New River Community College
Department of Electronics
Dublin, Virginia 24084
e-mail: NRSHIRM@nr.cc.va.us

This project was designed, developed and fabricated for the on-board electronics that are required for the wireless speed-control system. This system will be used on the mesicopter structure model. After evaluation of all the requirements and options, the system was designed and prototyped. The system is comprised of a process-control-transmitter-module, and a receiver module.

The process-control-transmitter-module consists of the following. First, a variable CMOS logic audio frequency oscillator, with a range of frequencies from approximately 2 to 4 kHz. The frequency of this oscillator and the speed (RPM) of the motor in the receiving module are inversely proportional to each other. At 2 kHz the RPM reaches a maximum rating of approximately 3500 and at 4 kHz the RPM is reduced to zero. Secondly, a FM transmitter, with a carrier frequency of 418 MHz, radiated power of 10dBm, and a radiation distance of 200 meters (on open ground).

The receiver module is composed of a FM demodulator, double integrator, amplifiers, pulse-width modulator, and a DC motor. The speed of the motor can be changed from zero to approximately 3500 RPM by the variable oscillator, which is located in the process-control-transmitter-module. This system was tested and carried out all the requirements successfully.

AERODYNAMIC UNCERTAINTY STUDIES

Arthur C. Taylor 3rd
Dept. of Mechanical Engineering
Old Dominion University

The use of aerodynamic sensitivity derivatives is explored in the context of aerodynamic uncertainty analysis using nonlinear CFD codes. Well-known formulae are employed to predict the mean and variance of an aerodynamic output function which is subjected to a normally-distributed, randomly-variable set of design parameters. Each of these predictive formulae has a first-order accurate version and a second-order accurate version; the latter requires that the second-order aerodynamic sensitivity derivatives be calculated (in addition to the first-order derivatives, of course).

The proposed methodology is demonstrated in application to the quasi-1D Euler equations for transonic flow with a normal shock in a converging-diverging nozzle. The sensitivity-based predictive methods are compared with results generated directly from a Monte Carlo simulation using the CFD code. Work-in-progress is reviewed with respect to extension of the methodology to transonic flow over an airfoil (i.e., 2D). Finally, special issues and difficulties associated with computing the second-order aerodynamic sensitivity derivatives are reviewed.

REPORTS FROM KITTY HAWK:

THE WRIGHT BROTHERS ON THE OUTER BANKS OF NORTH CAROLINA,

1900-1911

Larry E. Tise, Ph.D.
Wilbur and Orville Wright
Visiting Distinguished Professor of History
Department of History
East Carolina University
Greenville, N.C. 27858-4353
e-mail: ltise@ibm.net
[permanent address: PO Box 15782, Philadelphia, PA 19193]
[phone: 215.765.2418; fax: 215.765.2721]

As we approach the first centennial of flight--that is anniversary of "the first manned, powered, controlled, and sustained flight of a heavier-than-air aircraft" by the brothers Wilbur and Orville Wright in 1903--there is a growing and renewed interest in telling the story of the Wright Brothers and in recalling it accurately, authoritatively, and interestingly. A review of the literature on the Wright Brothers indicates that there is a growing and abundant literature on the Wrights and their great achievements, including a number of major biographies by Fred Howard, Wilbur and Orville: A Biography (1987), Tom Crouch, The Bishop's Boys: A Life of Wilbur and Orville Wright (1989), and Peter L. Jakob, Visions of a Flying Machine (1990). And the source material on the Wrights has presumed to be well covered in the authoritative editions by Marvin MacFarland of The Papers of Wilbur and Orville Wright (1953) and in Peter Jakob and Rick Young's The Published Writings of Wilbur and Orville Wright (2000). All are useful in charting the story of the Wright Brothers interaction with the Outer Banks area of North Carolina in general and the community of Kitty Hawk in particular.

However, as a result of an examination of the manuscript and photo collection of the Wright Brothers at the Library of Congress and of photo collections and other materials in the North Carolina State Archives and the Outer Banks History Center at Manteo, North Carolina, it is clear that a majority of the original sources wherein Wilbur and Orville Wright and their sister Katharine and father Milton chart their progress with experimental aircraft--kites, gliders, and powered flyers--have never been edited and published.

The thrust of this project has thus been to locate, identify, photocopy, and transcribe as fully as possible all unpublished documents and photographs deriving from or relating to the Wright brothers visits to North Carolina to experiment with flying machines in 1900, 1901, 1902, 1903, 1908, and 1911 and the interconnections they made with the Kitty Hawk community and the residents of the Outer Banks of North Carolina. A second goal of the project has been to index both published and unpublished sources in terms of the people the Wrights met on or brought to the Outer Banks, the flora and fauna they observed, and the places they visited.

An Analysis of the Performance of the Diode Laser Hygrometer During the Solve Mission

George F. Tucker, Ph.D.
The Sage Colleges
Physics Department
Albany, NY 12208
email: tuckeg@sage.edu

The Diode Laser Hygrometer (DLH) measures water vapor ($\text{H}_2\text{O}(\text{v})$) via absorption by a strong, isolated line at 7117.7 cm^{-1} (1.4049 microns) and is comprised of a compact laser transceiver mounted to a DC-8 window plate and a sheet of high grade retroreflecting road sign material applied to an outboard DC-8 engine housing to complete the optical path. Using differential absorption detection techniques, $\text{H}_2\text{O}(\text{v})$ is sensed along the 28.5m external path negating any potential wall or inlet effects inherent in extractive sampling techniques. A laser power normalization scheme enables the sensor to accurately measure water vapor even when flying through clouds. An algorithm calculates $\text{H}_2\text{O}(\text{v})$ concentration based on the differential absorption signal magnitude, ambient pressure, and temperature, and spectroscopic parameters that are measured in the laboratory. During the SAGE III Ozone Loss and Validation Experiment (SOLVE), a measurement campaign designed to examine the processes controlling ozone levels at mid- to high latitudes and to provide correlative data needed to validate the Stratospheric Aerosol and Gas Experiment (SAGE) III satellite measurements, the DLH made measurements during 30 flights. The $\text{H}_2\text{O}(\text{v})$ measurements obtained by the DLH will be used in an inter-comparison with data taken by another laser hygrometer, a cryogenic hygrometer, both of which were also onboard the DC-8, balloon borne frost-point hygrometers, and the Polar Ozone and Aerosol Measurement II satellite.

Because of concerns about the stability of the lock-in amplifier, used to measure the differential absorption signal, on eight flights one or two additional lock-in amplifiers were used. This investigation compared the stability of these amplifiers by intercomparing the signals obtained by each amplifier. The results indicate that all of the amplifiers exhibited instabilities, probably due mainly to phase drift. In addition, measurements made in the laboratory using a 3m calibration cell confirmed these findings. This allowed the accuracy of the DLH SOLVE data to be determined. However to improve the accuracy of the $\text{H}_2\text{O}(\text{v})$ measurements on future missions, lock-in amplifiers which provide quadrature information will be employed, allowing correction for phase drift. It is planned to implement these improvements for the next DLH deployment in November/December 2000.

Development of a Real Time Display for Noise Reduction Program

Jerry H. Tucker, Ph.D.
Virginia Commonwealth University
School of Engineering
Electrical Engineering Department
Richmond, VA 23284
e-mail: jhtucker@vcu.edu

A field-deployable digital acoustic measurement system (DAMS) was developed at NASA's Langley Research Center and has for several years been used to support acoustic research programs. The DAMS system digitizes information from multiple microphones that can be located up to 2000 feet from a van that houses the acquisition, storage, and analysis equipment. A common use for this system is to conduct tests from which noise signatures of aircraft during takeoff and landing can be developed. Data from flyover testing is typically collected and stored for several hours. The data is then analyzed overnight. During the test there is only minimum indication regarding the quality of the data actually being collected.

The existing DAMS system is being upgraded and enhanced to provide real time display and analysis of acoustic data. Providing this capability is the problem addressed by the current development effort.

For this development, one possibility was to attempt to expand the software on the existing system to provide for the real time display. This approach was rejected for several reasons. It was questionable that the existing system could support the additional overhead. Making extensive modifications to the working LabVIEW program would be difficult, time consuming, and possibly introduce errors into the working system. The approach chosen was to make simple modifications to the existing LabVIEW program to transfer raw data to a separate PC dedicated to the real time display task. This approach has the advantages of minimizing the impact on the existing hardware and software, reducing development time, enabling the new software to be written in any appropriate language, and facilitating the possibility of future enhancements.

In addition to providing the required real time display capability for DAMS, it is anticipated that this development can serve as a feasibility test bench for providing rapid remote access to test data, and can easily be incorporated into future data acquisition systems.

Development Of Training Modules And Its Effective Online/Offline Delivery Using Latest Technology

Arun K Verma
Hampton University
Hampton, VA

George D Allison and Mitch Thomas
Langley Research Center
Hampton, VA

Difficulty in coordinating a training/technical presentation/retraining for a group of participants and the trainer/presenter has always been a challenge. It is becoming more and more challenging with downsizing of the workforce, where one has to squeeze in a little more in the every day agenda. Schedules are getting more crowded. The importance of passing on the experiences gained over the years by some one to the next generation can not be underestimated.

With the available technology in this age professional development including training, retraining or presentations, do not have to be an added pain for the participants and should not be a challenge for organizers. Latest technology can be used to share experience with others, focus on fine details of a process, watch-outs, dos and don'ts, for desktop presentations and so on. It can also be used to make these items personalized and just fit according to ones need/requirement.

Using latest technology modules can be developed which will be more engaging and involving than current presentations. Experiences of outgoing/retiring personnel (lessons learned) can be captured and shared with relevant employee. They do not have to learn by committing the same mistakes (no reinvention of wheel). With the option of choosing selected segments of modules (personalized), a lot of time can be saved and if needed one can spend more time on the same segment/module.

A preliminary research of products related to codec and streaming media technologies, interactive multimedia tools capable of capturing, editing, organizing, converting, publishing and sharing modules, and web-deliverability was conducted. And accordingly development of such modules using macromedia products - authorware, dreamweaver, courseware, director; dazzle products - digital video creator II, sonic solutions, moviestar, DVDit, smartsound etc., is under progress. Claim by Microsoft Windows Media is also under consideration. The setup is near completion. The development work will continue including looking into few more effective, efficient and better software like pathware etc. in building such modules.

**The Application of Prismatic Elements
for the Solution of
Electromagnetic Eigenvalue Problems**

Gregory M. Wilkins, Ph.D.

**Morgan State University
Department of Electrical and Computer Engineering
Baltimore, Maryland 21251
gwilkins@eng.morgan.edu**

Active devices, consisting of thin doped layers adjacent to bulk material layers, are used in current millimeter-wave systems that include sensors or communication functions. The study of these devices may be considered as multi-scale electromagnetic field problems comprised of small regions with highly confined fields or charges adjacent to larger open regions where the fields are more smoothly varying. Similarly, guided-wave structures consisting of thin ferroelectric or ferromagnetic substrates are used for permittivity and permeability control in integrated circuit structures and in phase shifters for phased array applications. The models for these devices are typically nonlinear and involve the electromagnetic field equations and the ability to account for significant variation of material parameters in fine regions. The means of solution involves using finite volume or finite element methods solved on grids that require multi-scale meshes over regions of the electronic device, waveguide, or resonator.

The most general investigation is the consideration of three-dimensional geometries for which symmetry does not necessarily exist. These types of problems are often studied using tetrahedral elements as the means of discretization. However, the generation of these meshed regions tends to be cumbersome and, at times, inefficient. Tetrahedral elements often demonstrate an unstructured nature in all dimensions, adding to the complexity of the problem. This is particularly true if one of the dimensions of the problem is structured, that is, does not deviate from a fixed shape. Instead, the use of prismatic elements is beneficial since it allows for the regions to be meshed in an unstructured pattern in two dimensions, while maintaining structure in the third dimension. This approach, which uses a vector formulation, is very similar to the hybrid edge element approach, which uses both vector and scalar unknowns. An algorithm is developed and implemented to account for the field behavior in these types of devices by considerations of the variation in both location (inhomogeneity) and direction (anisotropy) of the materials comprising the device.

Analysis of Friction Stir Welded Lap Joints in Thin Sheet Aluminum Alloys

Keith M. Williamson, Ph.D
Department of Mechanical Engineering
Old Dominion University
Norfolk, VA 23529

Abstract

Friction Stir Welding (FSW) developed during the early 90s is a solid state joining process which provides a highly efficient method for joining aluminum and other alloys without complications typically associated with fusion welding. Complex thermomechanical effects induce large scale plastic deformations resulting in mixing patterns and dynamically recrystallized microstructures along the bond line. Despite tremendous advantages of FSW over fusion welding, age-hardenable aluminum alloys (2xxx, 6xxx, 7xxx, etc) suffer strength degradation of as much as 40% due to microstructural variations in regions near the FSW zone where large deformations in the unrecrystallized base metal causes excessive recovery of dislocation substructures.

These effects are closely related to thermal and stress fields as well as joint geometry. All three effects will be addressed in the current two-part study. In the first part of the study, the objective is to conduct uncoupled numerical investigations of the thermal and stress fields generated by the FSW tool during the fabrication of lap joints. Thermal investigations will focus on how imposed temperatures on the FSW backing plate affect thermal gradients in the tool and work-piece while investigation of the stress-fields will examine specific asymmetries in the behavior of material flow around the FSW tool. In the second part of the study, a theoretical framework will be developed to determine the effect of joint geometry on the strength of FSW lap joints.

User-Tracking Software for Gathering Detailed Web Site Statistics in a Restrictive Environment

**James Withington
Inter American University of Puerto Rico
Bayamon, PR 00957
jwithington@bc.inter.edu**

A method for gathering statistics on web site usage has been developed for governmental or other sites that operate under more restrictive policies than commercial ones. The software developed has been applied to a self-paced educational web site promoting computational fluid dynamics (CFD) that was also developed under the same project. Very little detailed information exists on how self-paced informational web sites are used, despite the rapid growth of their use both in government and commercial sectors. For the most part, only data regarding the "hit count," or number of times a page is viewed is publicly available. Obtaining user profiles and insight into user psychology is critically important in designing effective informational web resources. The pursuit of detailed user profiles and site usage in the government sector is made more difficult by restrictions placed on both the type of information that may be collected about web site users and the technical means by which it can be done.

With these restrictions in mind, customized web server software has been developed to store user profile and detailed site activity information in a database. A 12 page, self-paced tutorial on NASA's use of computational fluid dynamics was also created as a test web site. The site will be promoted through the existing educational infrastructure at NASA LTP (Learning Project Technologies). The software has been created in a generic form that could easily be integrated to other existing or new web sites. Statistics gathered by future use of the web site will give insight into user psychology and allow information to be gathered on how best to organize informational web sites in general. Specifically, data on the speed of progress through the site, sequential vs. random access of pages, number of return visits to the site as well as user profiles will be valuable in the development of future self-paced informational web sites.

APPENDIX VIII

2000 ASEE PROGRAM ORIENTATION EVALUATION REPORT

(Thirty-two Orientation evaluations were returned.)

1. Was the Orientation notification received in a timely manner?

1 - Poor - 0%	4 - Good - 7 (22%)
2 - Fair - 0%	5 - Excellent - 25 (78%)
3 - Average - 0%	

2. Were the meeting facilities adequate?

1 - Poor - 0%	4 - Good - 11 (34%)
2 - Fair - 0%	5 - Excellent - 21 (66%)
3 - Average - 0%	

3. Was the Welcome Package beneficial?

1 - Poor - 0%	4 - Good - 8 (25%)
2 - Fair - 0%	5 - Excellent - 24 (75%)
3 - Average - 0%	

4. How do you rate the Program Breakout Session?

1 - Poor - 0%	4 - Good - 10 (31%)
2 - Fair - 0%	5 - Excellent - 20 (63%)
3 - Average - 1 (3%)	No Answer - 1 (3%)

5. Was the information and knowledge gained at the Orientation helpful?

1 - Poor - 0%	4 - Good - 14 (44%)
2 - Fair - 0%	5 - Excellent - 14 (44%)
3 - Average - 3 (9%)	No Answer - 1 (3%)

6. In general, how do you rate this Orientation?

1 - Poor - 0%	4 - Good - 8 (25%)
2 - Fair - 0%	5 - Excellent - 23 (72%)
3 - Average - 0%	No Answer - 1 (3%)

7. Comments:

• Receiving more than one copy of the Orientation notification was excellent • Have a break sooner that last for at least 5 minutes • Breakout session was better than the morning session. Perhaps you could have 1 long videotape of the necessary (required) information and just show tapes in the breakout session. The big session could may be then be half as long. Also, how about some food. • Talk about issues of bringing your own things (e.g. Laptops) onto Langley. Also, bicycle issues would be helpful. • No suggestion, everything was excellent. • This was my 2nd year, so intro was a little duplicative - video's a little long. Use new slides in Langley too. • Breakout session room was a little cramped and stuffy, but location was nice. • Several speakers presented phone numbers and web addresses. It would be better to print up a page or contact list to give each participant. • Could put info about apartment websites (e.g. Apartments.pilotonline.com). Schedule a break earlier in the morning. • The unscheduled "2-minute stretch" break was a good idea. Multi-speaker, short presentations is the way to do it! • Need a calendar to note important dates! Should be able to get cheap calendar this late in the year. Would enjoy a joint LARSS ice breaker. • General orientation too long. Acquaint us with concerns and where to get info and ask questions. Streamline!! Try to get your best speakers for any length of time - Keep Ed Prior for the general overview. • All my questions were answered during this morning orientation. • The Orientation was excellent, but it was very technical and might have been done on day 2 rather than the first day. • Most of the stuff was so boring, but I guess that is to be expected. I hate these things so I cannot be objective. Don't put the ASEE Fellows with the LARSS students; they are not our peers.

APPENDIX IX

**NASA LANGLEY AMERICAN SOCIETY FOR ENGINEERING
EDUCATION (ASEE) SUMMER FACULTY FELLOWSHIP
PROGRAM**

2000

POLICIES,

PRACTICES,

and

PROCEDURES

MANUAL

A Handbook for ASEE SFFP Fellows

Table of Contents

Introduction	87
Definitions	88
Accepting a Fellowship and Beginning Tenure	89
Stipend	90
Relocation Allowance and Travel	91
Insurance	92
Taxes	92
Leave	93
Housing	94
Lecture Series	94
Activities Committee	95
Security	95
Safety	96
Mail Center	97
Library	98
Cafeteria	99
H.J.E. Reid Conference Center	100

Introduction

Since 1964, the National Aeronautics and Space Administration (NASA) has supported a program of summer faculty fellowships for engineering and science educators, whereby faculty members spend 10 weeks working with professional peers on research.

The ASEE program is administered by a collaborating university. Either a Co-Director from Old Dominion University (ODU) or Hampton University (HU), on alternate years, works with the NASA Langley Research Center (LaRC) University Affairs Officer, who is the Technical Monitor.

The faculty member will participate in three primary elements of the ASEE program which are: (1) a research project in cooperation with a NASA associate, (2) a study program consisting of technical lectures and seminars given by distinguished scientists and engineers from NASA, academia, or industry presented to program participants, and (3) a technical presentation and paper. Additional elements of this program include tours of LaRC wind tunnels, computational facilities, and laboratories. Library and computer facilities will be available for all participants.

The objectives of the program are: (1) to further the professional knowledge of qualified engineering and science faculty members, (2) to stimulate an exchange of ideas between teaching participants and employees of NASA, (3) to enrich and refresh the research and teaching activities of participants' institutions, and (4) to contribute to the research objectives of the Center.

The Policies, Practices, and Procedures Manual sets forth the conditions of your award, your responsibilities as an ASEE Fellow, and the procedures observed by the universities and the LaRC's Office of Education (OEd) in supporting and implementing your summer research program.

1.0 Definitions

1.1 ASEE Summer Fellow

As an ASEE Summer Fellow you are a faculty member, competitively selected by the LaRC Competencies in a national competition, who has been offered a fellowship to perform scholarly research on a problem of interest to NASA in the ASEE Summer Faculty Fellowship program.

You enjoy the status and privileges of a guest summer faculty Fellow at LaRC. You are not an employee of LaRC or the sponsoring Competency and do not perform personal services for either organization.

1.2 Langley Research Center

For the purposes of the ASEE Program, the terms “Center” and “LaRC” are used to refer to NASA’s Langley Research Center.

1.3 ASEE Associate

An ASEE associate is the scientist, engineer, or other program support person at the Center with whom you will work most closely. All matters relating to your research program will fall under his or her purview. The associate also assists, as needed, in securing space, equipment, or technical support.

1.4 ASEE Co-Director

The ASEE Co-Director from Hampton University (HU), working in conjunction with the LaRC University Affairs Officer as Technical Monitor, is responsible for the proper administration of the ASEE program. The Co-Director is available to discuss all aspects of the program with you, and he is your prime contact person in the OEd.

1.5 ASEE Program Manager/Administrative Assistant

The ASEE Program Manager/Administrative Assistant is a support-staff member who works closely with the ASEE Co-Director in the administration of the program, and acts as his representative in his absence. The Program Manager/Administrative Assistant is also available to answer any questions.

1.6 Approval

Throughout this handbook, various procedures are cited that require the exclusive approval of the Co-Director. The use of the word “approval” means written approval. Any document requiring the Co-Director’s approval must have the concurrence of the appropriate associate. Any actions taken on the basis of verbal concurrence are not binding on the Co-Director unless followed by appropriate written authorization.

2.0 Accepting a Fellowship and Beginning Tenure

2.1 Notification of a Fellowship

You will be notified of your ASEE Fellowship by an official selection letter that states the conditions of your fellowship, information concerning your stipend, and the period of your tenure at LaRC which will be for 10 weeks.

2.2 Acceptance Letter

Once you receive your selection letter, please notify us of your decision to accept or decline the fellowship not later than the date specified in your award letter. If your acceptance letter is not received by the specified date, your fellowship may be withdrawn.

If you are requesting an alternate start or end date, please do so in your acceptance letter. The approval of both the Co-Director and the Competency with whom you will be working is required before your tenure may officially begin. These approvals are necessary to ensure compliance with the Center's scheduling of research and its availability of support facilities.

You *must* also return the completed ASEE Personnel Security Paperwork and any other requested items in order to facilitate a security background check.

2.3 Information Package

Included with your selection letter is an Information Package. The purpose of this package is to provide you with information which will facilitate your stay at LaRC. Included in this package is the following:

- (a) Policies, Practices, and Procedures Manual and Signature Form
- (b) NASA ASEE Personnel Security Paperwork Package
- (c) NASA Fact Sheet
- (d) Map of the Area
- (e) Directions to NASA
- (f) Housing Information
- (g) Activities Interest Survey
- (h) Federal Regulation Form
- (i) NASA Education Evaluation Program Release Form

2.4 Working with the ASEE Associate

You are expected to maintain close contact with your assigned associate who will offer guidance in all aspects of your technical activities and assistance in acquiring research support facilities.

2.5 Change of ASEE Associate

If for any reason your assigned ASEE associate changes, you and the associate must notify the Co-Director immediately in writing. The change will not be effective until the Co-Director and OEd have concurred with the request.

2.6 Conforming to Center Policies

ASEE Fellows are expected to conform to all established policies and procedures of the sponsoring Center as they pertain to guest researchers and the safety and health of individuals working at the Center.

2.7 Extensions of Tenure

There will be no paid extensions of tenure. The only exception is at the **sole discretion and written approval of the Co-Director**. In order for him to consider an extension, he must receive a written memorandum submitted by the LaRC associate. This memorandum must outline the critical need for the extension well in advance of the program end date. At that point, the Co-Director will consider the request and may approve depending on funding availability.

3.0 Stipend

3.1 Federal Funding Regulation

*****Please Note: Fellows *must* understand that it is *illegal* to receive stipend or salary payments from other Federal funding sources including research grants and contracts while participating in a government-sponsored summer faculty fellowship. Failure to comply with this regulation may, at a minimum, result in termination of your fellowship. In addition, you may want to check the regulations at your institution regarding receipt of supplemental funding.*****

3.2 Stipend Amount

The amount of your stipend is \$1,000 per week. Stipends are paid on the basis of a 5-day, 40-hour work week; and are issued biweekly, beginning the third Tuesday of the ASEE program (actual stipend payment schedule provided upon arrival). Therefore, all ASEE Fellows should be prepared to provide for themselves financially the first 2 weeks of the program (Refer to Section 4.0).

3.3 Acceptance Letter

Your acceptance letter must be received before stipend payments can be authorized.

3.4 **Locator Form**

In the orientation package you receive on the day of your arrival, you will receive a Locator Form. This form must be completed and returned to the Program Manager/Administrative Assistant as soon as possible following your arrival. On this form, you will be requested to supply your local address and phone number, a person to contact in case of an emergency, and your actual physical location on Center, including Mail Stop, building address, building number, room number, and extension. **Once this form has been turned in, this office must be notified immediately if any changes are made.**

3.5 **Receiving Stipend Payments**

Your biweekly stipend payments are not available for deposit by electronic funds transfer (EFT). They must be picked up in person from the ASEE Program Manager/Administrative Assistant. In order to receive your stipend payment, you must bring your badge for proof of identification and sign the form confirming receipt of payment.

Final stipend payment will be made only after you have submitted your Final Abstract, the Program Questionnaire, the Final Report Forms, the Final Checkout Form with appropriate signatures, your badge and pass, and any additional information required. If you will not be on Center the last day when stipend checks are available, submit to the Co-Director a signed memo indicating the address to which your check is to be mailed if different from your permanent home address.

3.6 **Cashing Your Stipend Checks**

Crestar Bank: Your stipend checks are cut from Nations Bank and you may cash it at any of their branches free of charge.

Langley Federal Credit Union (LFCU): LFCU offers check cashing privileges for a fee. Due to their policy, you will be unable to open an account or cash personal checks.

4.0 **Relocation Allowance and Travel**

4.1 **Relocation Allowance**

A relocation allowance of \$1,000 will be provided to any Fellow who is required to relocate their residence because their home/school address is more than 50 miles from NASA Langley Research Center. This is provided to assist in the additional expenses incurred in relocating to the Tidewater area. No receipts are required.

4.2 **Travel Reimbursement**

Fellows are reimbursed for their travel under the following terms:

- Round trip coach air fare (receipt required) or,
- Round trip mileage up to the cost of coach air fare, maximum \$500.

Meals and overnight accommodations are the Fellow's responsibility. A travel expense form will be provided in your welcome package and should be filled out and returned to the Program Manager/Administrative Assistant at the Orientation in order to ensure prompt processing. Both the relocation allowance and travel reimbursement will be provided at the next pay date following submission of your information if time allows.

5.0 Insurance

5.1 Health and Medical Insurance

It is the responsibility of the ASEE Fellow to have the appropriate health and medical insurance coverage. The ASEE program does not provide any insurance coverage. Experience has shown that coverage for you and your dependents is extremely beneficial. Unless you already have insurance coverage, you are advised to weigh carefully the cost/risk factor in reaching a decision to participate in this program.

5.2 Worker's Compensation Type Insurance

ASEE Fellows are not covered by any type of Worker's Compensation Insurance through the ASEE program. If injured while on duty, however slight, immediately notify your associate and the Co-Director at (757) 864-5215. Emergency medical assistance can be obtained from the Occupational Health Services Clinic, Building 1149, from 7:00 a.m. to 3:30 p.m. In a medical emergency, dial 911.

5.3 Automobile Insurance and Driver's License

You must have a valid driver's license, automobile insurance, and a current inspection sticker to certify that your automobile is safe and to be issued a Vehicle Pass to drive on-Center.

6.0 Taxes

6.1 Federal Tax Liability of United States Citizens

Since you are not an employee of NASA LaRC or HU, but are an ASEE Fellow and considered self-employed, neither the OEd nor HU withholds taxes from stipend payments to you. You will receive from the university, a form 1099 indicating your total stipend.

You should refer to the pertinent tax publications and plan ahead to meet any tax obligations, both federal and state, if applicable, and file your returns as required by Federal law. The responsibility

for the payment of your income taxes rests solely with you. The OEd and HU cannot provide information or consultation concerning income taxes.

6.2 Social Security Taxes

Since you are not an employee of NASA LaRC or HU, but are an ASEE Fellow and considered self-employed, neither the OEd nor HU withholds Social Security Taxes from your stipend payments. You should refer to the pertinent publications on Social Security Taxes to determine whether you have incurred any tax obligation. Although Social Security Taxes are not withheld from stipend payments, you are nonetheless required to have an assigned Social Security Number.

6.3 State Tax Liability

You may be liable for state income taxes and should file the appropriate tax return in compliance with the laws of the state in which you reside. You should consult a local government tax authority at the beginning of tenure for further details concerning this liability.

7.0 Leave

7.1 Leave

As a guest researcher in the 10-week ASEE Program, you are not eligible for annual leave, sick leave, or personal leave.

If there are reasons why you need to be absent from work during the summer research experience, there are a few steps you must take **prior** to the absence. First, you must clear this absence with your LaRC associate. Next, submit a memo to the ASEE Co-Director with your associate's concurrence requesting approval for your absence. This is to include any conferences or presentations of papers. If this absence is directly related to your summer research and a memo to that effect is submitted by your associate, then time approved can be considered a part of your 10 week tenure. If you are approved to attend a conference not related to your summer research, then the time away **must be made up** before receiving your final stipend check. **If you are aware, prior to the start of the summer program, of a meeting or conference you desire to attend during the 10-week period, we ask that you request approval for this absence as soon as possible to allow for timely processing.**

7.2 Work Hours

The typical work schedule is from 8 a.m. to 4:30 p.m. Once you arrive on Center, you will need to conform to the schedule applicable to your Branch, as schedules may vary.

7.3 Working After Hours

After hours access and work at LaRC after 6 p.m. require an authorized LaRC badged escort. Unescorted after hours work is discouraged; however, in special situations in order for you to work after hours several steps must be taken. You must first have the approval of your LaRC associate sponsor. Your associate must submit to the Security Management Office (SMO) a Request for Unescorted After Hours Access (Langley Form 218) for you to work unescorted after hours. Also, a favorable background check and investigation must be completed on you by the SMO before unescorted after-hours access is granted. This information is subject to change.

8.0 Housing

8.1 Housing Package

The ASEE Office provides information on short-term leasing to those Fellows who require housing while in the ASEE Program. Included with your award letter is a Housing Package with pertinent information.

8.2 Disclaimer

It is the Fellow's responsibility to contact the apartment complex, etc., to finalize all housing arrangements. You are strongly encouraged to make these arrangements as early as possible since short term leases are in great demand during the summer due to the influx of people into the area. **Neither ASEE, NASA, HU, nor any staff representatives shall intercede in the lease agreement made between the tenant and the landlord.** This information is provided for the sole purpose of assisting you in making your transition to the Tidewater area easier. Once again, the only form of financial assistance provided for your housing is the relocation allowance (See Section 4.1). It is recommended that as soon as you know your departure date, you submit this information **in writing** to the complex management.

9.0 Lecture Series

9.1 Attendance

Weekly attendance at the Lecture Series by all Fellows is **strongly** encouraged. The purpose of the Lecture Series is to expand the knowledge of the professors with hopes of enhancing their classroom teaching and to give a greater knowledge of NASA's special research activities being conducted at the Center.

9.2 Distribution of Information

The weekly Lecture Series will also be used as an avenue to distribute pertinent program information, including stipend checks.

10.0 Activities Committee

A voluntary activities committee will be formed at the onset of the program. This committee will plan various after work activities for the Fellows and their families. Participation in any activity is solely on a voluntary basis, and neither NASA nor HU assume any responsibility for any events.

11.0 Security and Center Access Requirements

11.1 Personnel Security Screening Requirements

As a prerequisite for employment and access to NASA Langley Research Center (LaRC) facilities, programs and information, all participants in the American Society for Engineering Education (ASEE) Summer Faculty Fellowship program at LaRC are required to complete the Personnel Security Screening Forms (NASA Form 531, "Name Check Request," OPM Optional Form 306, "Declaration for Federal Employment," and FCRA Credit Release Authorization Form), which are included in your Information Package. All forms are to be completed, per the LaRC Security Management Office (SMO) instructions, and returned to the address listed below 45 days prior to reporting to work at NASA LaRC. Completed forms are to be mailed to NASA Langley Research Center, ATTN: Mrs. Debbie Murray, MS 400-ASEE, 17 Langley Blvd., Hampton, VA 23681-2199.

11.2 LaRC Access Requirements

A LaRC issued Photo Identification Badge is required for access to the Center. This badge permits ASEE Summer Faculty Fellowship program participants unescorted access to the Center during normal duty hours only. Normal duty hours at LaRC are from 6 a.m. to 6 p.m., Monday through Friday. Access during other than normal duty hours must be under escort. (See Section 7.3 Working After hours)

11.3 ASEE Summer Employee Orientation

Upon initial arrival at NASA LaRC, all ASEE Summer Faculty Fellowship program participants will attend a special ASEE Summer Employee Orientation session at the Reid Conference Center. When entering the Center on initial entry day, inform the Security Officer on duty at the LaRC Main Gate that you are an ASEE Summer Faculty Fellowship program participant and here to attend the ASEE Summer Employee Orientation session at the Reid Conference Center. The Security Officer will give you a Temporary Restricted Area Visitor Pass and direct you to the Conference Center.

11.4 Identification Badges and Vehicle Passes

A 5-day Temporary LaRC Identification Badge will be issued to ASEE Summer Faculty Fellowship program participants at the ASEE Summer Employee Orientation session. ASEE program participants must then report to the Main Gate Badge & Pass Office within 5 working days after the orientation to receive their extended **Temporary LaRC Photo Identification Badge and Vehicle**

Pass. A valid driver's license or other authorized photo identification is required for issuance of a LaRC Identification Badge and Vehicle Pass. NOTE: Before a LaRC Identification Badge can be issued, however, the completed Personnel Security Screening Forms must have been submitted through the Office of Education to the Security Management Office.

LaRC identification badge must be worn and in full view at all times while on Center. If LaRC identification badge is forgotten, lost or stolen, report immediately to the Badge and Pass Office at Bldg. 1228 for issuance of a temporary replacement badge.

11.5 Checkout Requirements

At the end of your work assignment, ASEE Summer Faculty Fellowship program participants are required to check out through the Office of Education and turn in their LaRC Photo Identification Badge and Vehicle Pass at that time.

For additional security information and questions, contact the LaRC Security Management Office at 757-864-3420/3535.

12.0 Safety

12.1 Safety Program

The objective of this program is to ensure each Fellow a safe and healthful working environment that is free from unacceptable hazards which could result in property damage, injury, or loss of life. The Langley Safety Manual is a compilation of documents which sets forth procedures pertinent to the safety operations of the Langley Research Center.

Each facility/building has a designated Facility Safety Head and Facility Coordinator (published in the LaRC Telephone Directory) responsible for ensuring adherence to safety rules and regulations.

12.2 Hazardous Communications Training

All Fellows are required to receive Hazardous Communications Training. This training provides awareness of dealing with chemicals which are physical or health hazards.

12.3 Safety Clearance Procedures

These procedures are used to ensure personnel or equipment safety during installation, maintenance, or in any situation where an equipment configuration must be temporarily maintained for the protection of personnel or equipment. The red tag may be placed upon any device which could, if actuated, cause personnel or property to be endangered. The red tag may also be used to forbid entrance to dangerous areas.

No person, regardless of position or authority, is to operate any switch, valve, or equipment which

has a red tag attached to it, nor will such tag be removed except as directed by an authorized authority.

12.4 Accident Reporting

Fellows shall immediately report all job related accidents, injuries, diseases or illnesses to their associate, the Co-Director, and the Office of Safety, Environment and Mission Assurance (OSEMA), 757-864-SAFE (757-864-7233). Emergency medical assistance can be obtained from the Occupational Health Services Clinic, Building 1149, from 7:00 a.m. to 3:30 p.m. In a medical emergency, dial 911.

12.5 Personnel Certification

It is LaRC policy to certify Fellows performing tasks which could be potentially hazardous to either the individual or co-workers. These requirements vary with the type of activity being performed, and consequently are described in detail in the LaRC Safety Manual dealing with the specific topic/hazard. Particular research assignments may require training, certification, and medical surveillance requirements. Examples of these types of research assignments are chemical, radiation and/or pyrotechnic operations.

13.0 Mail Center

13.1 Official Mail

The LaRC mail system is only to be used for official mail. All offices are assigned a Mail Stop to which mail is routed. ASEE Fellows typically share a Mail Stop with their associates. One mail delivery is made each day to in/out boxes located near the mail stop custodian. Distribution of packages and boxes which are too large for internal mail distribution are made to a designated table located in each facility.

Messenger envelopes are used to send mail internally. Before placing the envelope in the mail system cross out the previous name and Mail Stop, fill in the addressee's name and Mail Stop. Internal mail cannot be delivered without a Mail Stop.

If you change your work site, it is your responsibility to complete NASA Langley Form 41, "Langley Research Center (LaRC) Directory Change Notice," (located in the back of the Langley Telephone Directory). This form is used to place your name on internal mailing lists, and it is necessary that this information be kept up-to-date.

13.2 Personal Mail

Personal mail may be placed in the U.S. Post Office boxes located in front of the Cafeteria and

Langley Federal Credit Union. Additionally, the Langley Exchange Shop, located in the cafeteria, will mail your personal packages.

13.3 Additional Items to Remember:

- Do not use official Government envelopes for personal mail.
- For fastest delivery by the post office: address envelopes in all capital letters, no punctuation, use state abbreviations, and zip code.
- Each piece of mail requiring postage must be stamped with the mail stop of the originating organization for identification.
- Do not use NASA Langley Research Center as a mailing address for personal mail.
- Do not send personal mail (cards, chain letters, job resume, etc.) in the internal mail delivery system.
- When addressing messenger envelopes, use first and last name. Do not use nicknames.
- Do not use room numbers in place of mail stops on messenger envelopes.
- Mail Stops are required for delivery of internal mail.

If you have any questions, please call the Mail Manager, 757-864-8159.

13.4 Electronic Communications

The LaRC telephone, fax, and electronic mail system is to be used for official use only. LaRC conducts random monitoring of telephone lines and all electronic mail systems for unauthorized use. If you have any questions, please call the Network Support Office at 757-864-7777.

14.0 Library

The Technical Library serves the information needs of the NASA Langley personnel with its Technical Information Specialists, information systems for user desktop access, on-site collection, and access to worldwide resources and databases. The library is aggressively dedicated to maximizing the desktop delivery of pertinent, customized information databases, products and services.

Currently the library holds a comprehensive collection of materials in both print and electronic formats, covering the areas of aeronautics, structures and materials, space science, atmospheric sciences, and management. This includes 70,000 books, 800 journal subscriptions, over 2 million technical reports and access to more than 500 commercial and government electronic databases. At present, the library's information systems include NASA Galaxie, an on-line catalog; a CD-ROM

database network; Electronic Journals; NASA Research Connection (RECON); and current awareness services. Most of these are accessible through the Technical Library homepage located on the WWW at <http://library-www.larc.nasa.gov>.

To attain access to library services and computer systems, participants must be listed on the official American Society for Engineering Education (ASEE) Summer Faculty Fellowship Program roster issued by the OEd. Basic services include loan of books and documents, access to the library's on-line systems, and literature searches by Information Specialists. *ASEE participants must return all loaned materials to the library 2 weeks prior to the conclusion of the program. If materials are not returned, there will be a delay in receipt of the final stipend check. Lost items must be replaced before participant's library account is cleared.*

15.0 Cafeteria

15.1 NASA Exchange Cafeteria

Locations:	16 Taylor Drive, Building 1213 and 5 North Dryden, Building 1202
Hours of Service:	Monday through Friday
Breakfast:	6:15 a.m. - 8:30 a.m. - Main Cafeteria only
Lunch:	10:45 a.m. - 1:30 p.m.
Holidays:	Closed

15.2 Additional Items to Remember

Busiest Time:	11:30 a.m. to 12:15 p.m.
Reservations:	None Taken between 11:30 a.m. - 12:30 p.m. Large groups after 12:30 p.m.

15.3 Check Writing Policies

Checks are accepted from badged summer program participants for amount of purchase only.

15.4 Area Tickets Available

Discount tickets for Busch Gardens, Water Country, Kings Dominion, AMC and Regal Theaters, and Colonial Williamsburg can be obtained at the Exchange Shop in the Cafeteria. If you are interested in tickets, call 757-864-1585.

16.0 H.J.E. Reid Conference Center

16.1 Conference Center

The Conference Manager serves as a consultant and advisor for conferences and technical meetings. Reservations can be made for the following locations:

H.J.E. Reid Conference Center (Auditorium, Langley, Hampton, and Wythe Rooms)
14 Langley Boulevard

Pearl I. Young Theater
5A N. Dryden Street

Executive Conference Center (Rooms 107, 205, & 209)
3 S. Wright Street

7 X 10 Facility - Room 200
17 W. Taylor Road

Call 757-864-6362 for reservations.

16.2 Picnic Shelters

There are two picnic shelters on the grounds of the Reid Conference Center that can be reserved for office picnics. For reservations, call 757-864-6369.

16.3 NASA Gym

The NASA Gym is open from 11 a.m. to 1 p.m. Tuesday and Thursday, and 12:00 noon to 1:30 p.m. Monday, Wednesday, and Friday. Also, there is a free aerobics class from 11:00 a.m. to 11:45 a.m. Monday, Wednesday, and Friday.

The Langley Activities Association sponsors Bingo on Thursday nights, a Social Hour every other Friday evening, and a dance every other Saturday evening beginning at 7 p.m.

16.4 LaRC-sponsored clubs:

Aerobics Club
Astronomy Club
Basketball League
Bowling League
Flag Football
Golf Association
Radio Model Club

Amateur Radio Club
Apiculture Club
Bicycle Safety Club
Conservation Club
Garden Club
Karate Club
Runners Club

Science Fiction Club
Tennis Club

Softball League
Volleyball League

16.5 Additional Information

If you would like to see exhibits on NASA or view a featured film in an IMAX theater, you can visit the Virginia Air & Space Center in downtown Hampton.

REPORT DOCUMENTATION PAGE			Form Approved OMB No. 0704-0188	
Public reporting burden for this collection of information is estimated to average 1 hour per response, including the time for reviewing instructions, searching existing data sources, gathering and maintaining the data needed, and completing and reviewing the collection of information. Send comments regarding this burden estimate or any other aspect of this collection of information, including suggestions for reducing this burden, to Washington Headquarters Services, Directorate for Information Operations and Reports, 1215 Jefferson Davis Highway, Suite 1204, Arlington, VA 22202-4302, and to the Office of Management and Budget, Paperwork Reduction Project (0704-0188), Washington, DC 20503.				
1. AGENCY USE ONLY (Leave blank)		2. REPORT DATE September 2000	3. REPORT TYPE AND DATES COVERED Contractor Report (June 5-Aug. 11, 2000)	
4. TITLE AND SUBTITLE 2000 NASA-HU American Society for Engineering Education (ASEE) Summer Faculty Fellowship Program			5. FUNDING NUMBERS NCC-1-358	
6. AUTHOR(S) William P. Marable and Deborah B. Murray (Compilers)				
7. PERFORMING ORGANIZATION NAME(S) AND ADDRESS(ES) Hampton University Hampton, VA 23668			8. PERFORMING ORGANIZATION REPORT NUMBER	
9. SPONSORING/MONITORING AGENCY NAME(S) AND ADDRESS(ES) National Aeronautics and Space Administration Langley Research Center Hampton, VA 23681-2199			10. SPONSORING/MONITORING AGENCY REPORT NUMBER NASA/CR-2000-210327	
11. SUPPLEMENTARY NOTES Langley Technical Monitor - Roger A. Hathaway				
12a. DISTRIBUTION/AVAILABILITY STATEMENT Unclassified-Unlimited Subject Category 80 Distribution: Nonstandard Availability: NASA CASI (301) 621-0390			12b. DISTRIBUTION CODE	
13. ABSTRACT (Maximum 200 words) Since 1964, the National Aeronautics and Space Administration (NASA) has supported a program of summer faculty fellowships for engineering and science educators. In a series of collaborations between NASA research and development centers and nearby universities, engineering faculty members spend 10 weeks working with professional peers on research. The Summer Faculty Program Committee of the American Society for Engineering Education supervises the programs. Objectives: (1) To further the professional knowledge of qualified engineering and science faculty members; (2) To stimulate and exchange ideas between participants and NASA; (3) To enrich and refresh the research and teaching activities of participants' institutions; (4) To contribute to the research objectives of the NASA center. Program Description: College or university faculty members will be appointed as Research Fellows to spend 10 weeks in cooperative research and study at the NASA Langley Research Center. The Fellow will devote approximately 90 percent of the time to a research problem and the remaining time to a study program. The study program will consist of lectures and seminars on topics of interest or that are directly relevant to the Fellows' research topics. The lecture and seminar leaders will be distinguished scientists and engineers from NASA, education, and industry.				
14. SUBJECT TERMS ASEE-NASA Summer Faculty Fellowship Program ASEE-NASA Administrative Report			15. NUMBER OF PAGES 113	
			16. PRICE CODE A06	
17. SECURITY CLASSIFICATION OF REPORT Unclassified	18. SECURITY CLASSIFICATION OF THIS PAGE Unclassified	19. SECURITY CLASSIFICATION OF ABSTRACT Unclassified	20. LIMITATION OF ABSTRACT UL	