

40th Space Congress 2003
International Space Station Advances, Mission Milestones, Mission Operations

Verification of International Space Station Component Leak Rates by Helium Accumulation Method

Steve D. Underwood
Boeing Leak Test Engineer

Sherry L. Smith
Boeing Leak Test Engineer

Contact Author:
Steve Underwood
The Boeing Company
Integrated Defense Systems
International Space Station Program
499 Boeing Blvd.
P.O. Box 240002, M/S JT-03
Huntsville, AL 35824-6402
Work: (256) 961-1030
steve.d.underwood@hsv.boeing.com

ABSTRACT

Discovery of leakage on several International Space Station U.S. Laboratory Module ammonia system quick disconnects (QDs) led to the need for a process to quantify total leakage without removing the QDs from the system. An innovative solution was proposed allowing quantitative leak rate measurement at ambient external pressure without QD removal. The method utilizes a helium mass spectrometer configured in the detector probe

mode to determine helium leak rates inside a containment hood installed on the test

component. The method was validated through extensive developmental testing. Test results showed the method was viable, accurate and repeatable for a wide range of leak rates. The accumulation method has been accepted by NASA and is currently being used by Boeing Huntsville, Boeing Kennedy Space Center and Boeing Johnson Space Center to test welds and

valves and will be used by Alenia to test the Cupola. The method has been used in place of more expensive vacuum chamber testing which requires removing the test component from the system.

TEST METHOD DEVELOPMENT

The Space Station Modules have many components, which are leak tested at the bench level before module integration. For various reasons it is sometimes necessary to retest the components in place, after integration. The Laboratory Module Ammonia QDs were originally tested at the manufacturer in a vacuum chamber utilizing a helium mass spectrometer. The vacuum chamber is an accurate method for quantifying leak rates and verifying the QDs met their leakage requirement of $1E-4$ sccs helium. However after installation, QD leakage due to seal contamination was detected during Lab Module ammonia system weld testing. The detector probe method used to test the welds is a qualitative method and did not provide the accuracy needed to quantify the

QD leakage. It was determined through a series of developmental tests that QD leak rates

could be measure in place, by concentrating QD leakage in a containment hood and comparing peak detector probe responses with those of a known leak in the same enclosure. The developmental test setup is shown in Figure 1. A containment enclosure made of plastic and tape is installed over a QD volume simulator. The helium mass spectrometer is configured for detector probe operation and the probe is inserted into the bag for initial background measurement. Calibrated sources of various leak rates are inserted into the bag for a predetermined time period as shown in Figure 2. At the end of the time period the detector probe is inserted into the bag and the maximum mass spectrometer response is recorded. Enclosure sensitivity is determined from this data.

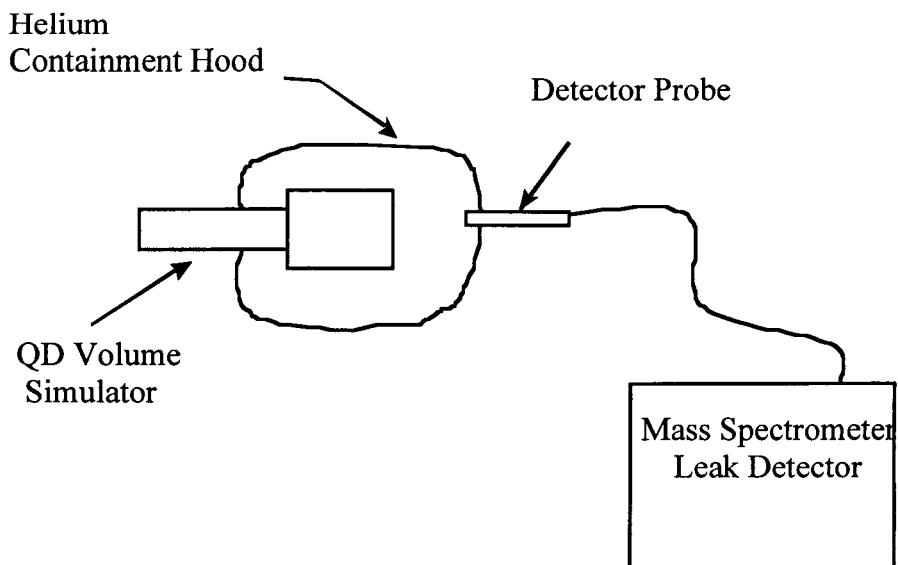

Figure 1: Accumulation Developmental Leak Test Setup

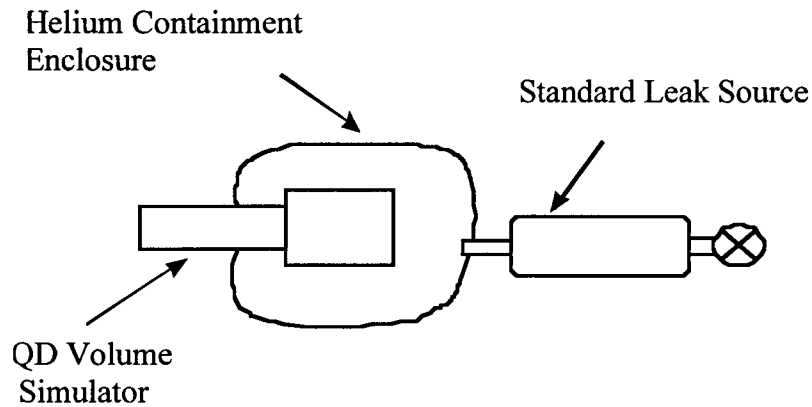

Figure 2: Enclosure Calibration

DEVELOPMENTAL TESTING RESULTS

Developmental tests were performed to collect accumulation data for various enclosure volumes, leak sizes and accumulation times. Initial development tests were performed with the following standard leaks: $1\text{E-}6$ sccs He, $4.2\text{E-}6$ sccs He, $1.0\text{E-}4$ sccs He, $1.3\text{E-}3$ sccs He. Sensitivities were determined for the enclosure with each standard leak. Ambient background measurements were taken and each standard leak was inserted into the enclosure for an accumulation time of 15 minutes. After

15 minutes the detector probe was inserted into the enclosure and the maximum mass spectrometer reading was recorded. The enclosure was purged with air before each calibration to ensure a consistent helium background throughout the test. Fig 3 shows the mass spectrometer output resulting from each standard leak. The standard leak size and the resulting enclosure sensitivity are denoted on the figure. More developmental tests were conducted to gather similar accumulation data on different types and sizes of enclosures, and longer and shorter accumulation times, prior to applying the method to flight hardware acceptance testing.

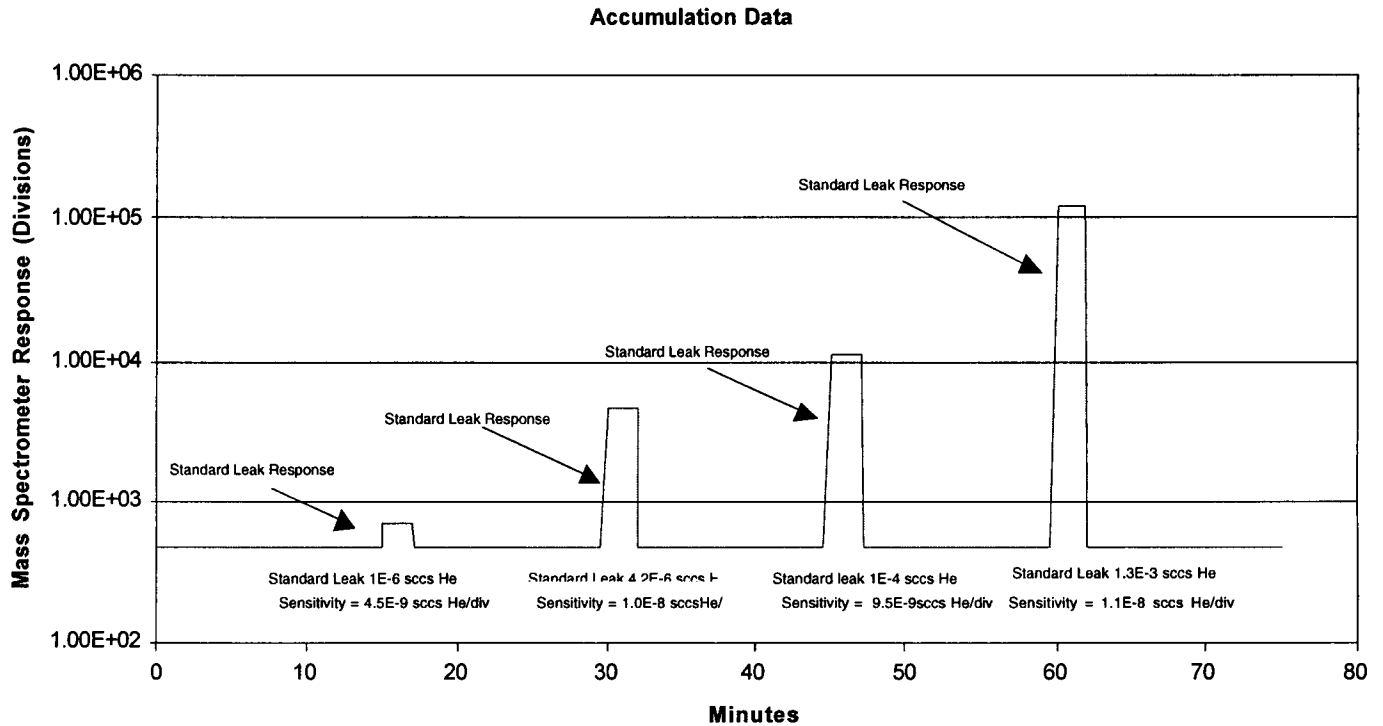

Figure 3: Accumulation Developmental Test Typical Results

FLIGHT HARDWARE ACCEPTANCE TESTING

Leak testing of the flight QDs on the Lab Element ammonia system QDs began in May of 1999. The method has since been utilized for leak testing welds, heat exchangers, racks, hoses, and will be used to test the Space Station Cupola Module. Several QD problems were identified and corrected through use of the accumulation method. Figure 4 shows actual data from Lab Element ammonia quick disconnect (QD-1), with leakage exceeding the 3E-4 sccs He requirement. The first response on the graph is from the 1E-4 sccs He standard leak used for the enclosure calibration. The

resulting enclosure sensitivity is denoted on the graph. Calibration accumulation time was fifteen minutes. The ammonia system was pressurized to 500 psig He and allowed to stabilize for three hours. At the end of three hours the enclosure was purged with air, which began the fifteen minute accumulation period. The second response on the graph is from the QD leakage and the leak rate was determined to be 7.3E-3 sccs. Figure 5 shows data from Lab Element ammonia quick disconnect (QD-2), with leakage below the 3E-4sccs He requirement. The test performed on QD-2 was identical to QD-1 and the leak rate was determined to be 5.3E-5 sccs He.

Flight QD-1

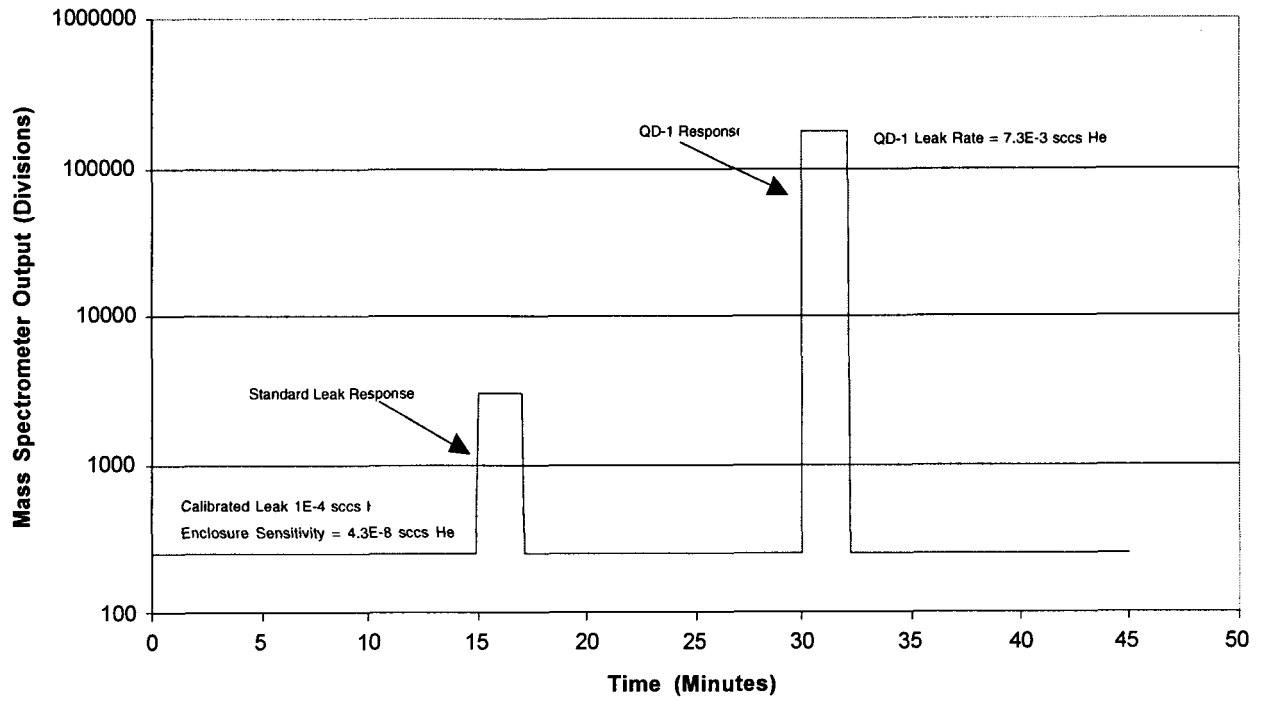

Figure 4: QD-1 Test Results

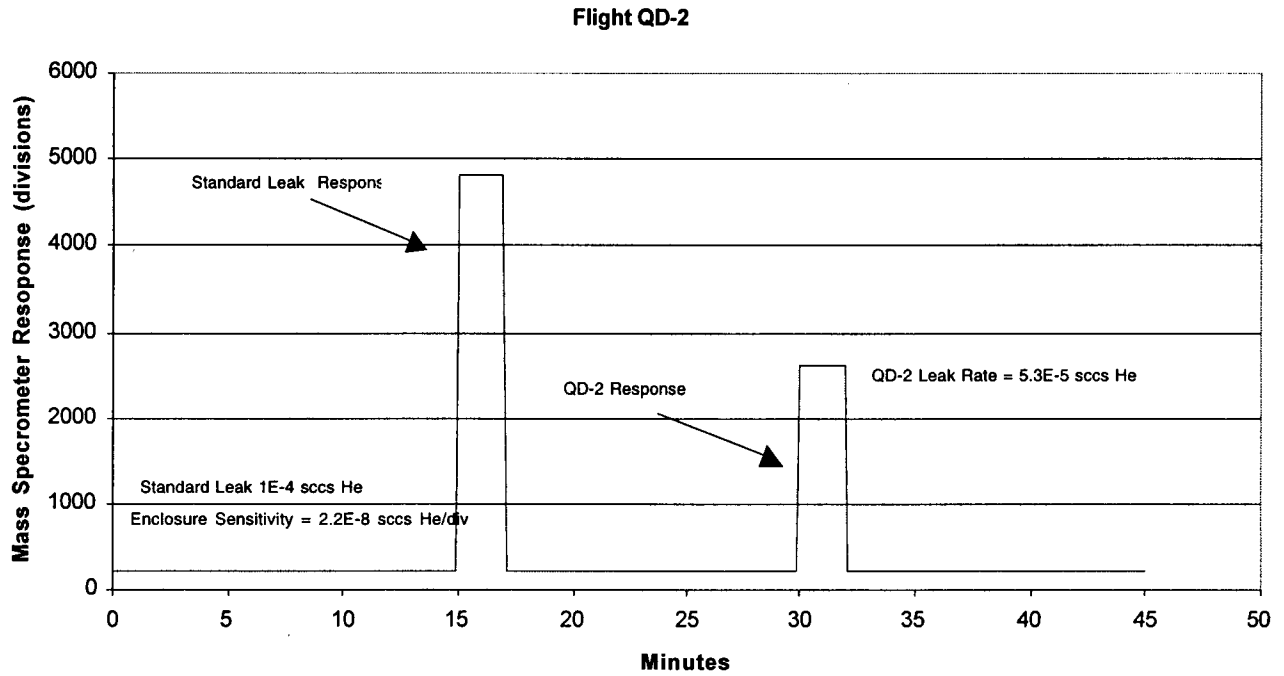

Figure 5: QD-2 Test Results

CONCLUSIONS AND SUMMARY

ISS leak test engineers verified that it is possible to accurately and consistently quantify the leakage rate of pressurized components at ambient test conditions, utilizing a helium mass spectrometer configured in the detector probe mode. Verification was performed on volumes ranging from a few cubic centimeters to 30 cubic feet, and leak rates ranging from $1\text{E-}6$ sccs helium up to $1\text{E-}2$ sccs. It is not necessary to know the enclosure volume or the test article volume and it is not critical that the enclosure have a specific leakage as this is taken into account when the sensitivity is determined.