

NASA/TM-2008-215105



Eddy Current COPV Overwrap and Liner Thickness Measurement System and Data Analysis for 40-Inch Kevlar COPVs SN002 and SN027

*Russell A. Wincheski
Langley Research Center, Hampton, Virginia*

January 2008

The NASA STI Program Office . . . in Profile

Since its founding, NASA has been dedicated to the advancement of aeronautics and space science. The NASA Scientific and Technical Information (STI) Program Office plays a key part in helping NASA maintain this important role.

The NASA STI Program Office is operated by Langley Research Center, the lead center for NASA's scientific and technical information. The NASA STI Program Office provides access to the NASA STI Database, the largest collection of aeronautical and space science STI in the world. The Program Office is also NASA's institutional mechanism for disseminating the results of its research and development activities. These results are published by NASA in the NASA STI Report Series, which includes the following report types:

- **TECHNICAL PUBLICATION.** Reports of completed research or a major significant phase of research that present the results of NASA programs and include extensive data or theoretical analysis. Includes compilations of significant scientific and technical data and information deemed to be of continuing reference value. NASA counterpart of peer-reviewed formal professional papers, but having less stringent limitations on manuscript length and extent of graphic presentations.
- **TECHNICAL MEMORANDUM.** Scientific and technical findings that are preliminary or of specialized interest, e.g., quick release reports, working papers, and bibliographies that contain minimal annotation. Does not contain extensive analysis.
- **CONTRACTOR REPORT.** Scientific and technical findings by NASA-sponsored contractors and grantees.

- **CONFERENCE PUBLICATION.** Collected papers from scientific and technical conferences, symposia, seminars, or other meetings sponsored or co-sponsored by NASA.
- **SPECIAL PUBLICATION.** Scientific, technical, or historical information from NASA programs, projects, and missions, often concerned with subjects having substantial public interest.
- **TECHNICAL TRANSLATION.** English-language translations of foreign scientific and technical material pertinent to NASA's mission.

Specialized services that complement the STI Program Office's diverse offerings include creating custom thesauri, building customized databases, organizing and publishing research results ... even providing videos.

For more information about the NASA STI Program Office, see the following:

- Access the NASA STI Program Home Page at <http://www.sti.nasa.gov>
- E-mail your question via the Internet to help@sti.nasa.gov
- Fax your question to the NASA STI Help Desk at (301) 621-0134
- Phone the NASA STI Help Desk at (301) 621-0390
- Write to:
NASA STI Help Desk
NASA Center for AeroSpace Information
7115 Standard Drive
Hanover, MD 21076-1320

NASA/TM-2008-215105



Eddy Current COPV Overwrap and Liner Thickness Measurement System and Data Analysis for 40-Inch Kevlar COPVs SN002 and SN027

Russell A. Wincheski
Langley Research Center, Hampton, Virginia

National Aeronautics and
Space Administration

Langley Research Center
Hampton, Virginia 23681-2199

January 2008

The use of trademarks or names of manufacturers in this report is for accurate reporting and does not constitute an official endorsement, either expressed or implied, of such products or manufacturers by the National Aeronautics and Space Administration.

Available from:

NASA Center for AeroSpace Information (CASI)
7115 Standard Drive
Hanover, MD 21076-1320
(301) 621-0390

National Technical Information Service (NTIS)
5285 Port Royal Road
Springfield, VA 22161-2171
(703) 605-6000

Eddy Current COPV Overwrap and Liner Thickness Measurement System and Data Analysis for 40-Inch Kevlar COPVs SN002 and SN027

Buzz Wincheski
NASA Langley Research Center

Introduction

As part of the health assessment of flight spare 40 inch diameter Kevlar composite overwrapped pressure vessels (COPVs) SN002 and SN027 an eddy current characterization of the composite and liner thickness change during pressurization was requested under WSTF-TP-1085-07.A, “*Space Shuttle Orbiter Main Propulsion System P/N MC282-0082-0101 S/N 002 and Orbital Maneuvering System P/N MC282-0082-001 S/N 027 COPV Health Assessment*” [1]. The through the thickness strains have been determined to be an important parameter in the analysis of the reliability and likelihood of stress rupture failure [2]. Eddy current techniques provide a means to measure these thickness changes based upon the change in impedance of an eddy current sensor mounted on the exterior of the vessel [3-6]. Careful probe and technique design have resulted in the capability to independently measure the liner and overwrap thickness changes to better than +/- 0.0005 in. at each sensor location. Descriptions of the inspection system and test results are discussed below.

Instrumentation

The inspection system was designed using a commercially available eddy current impedance plane instrument with custom wound eddy current sensors. In addition, a probe mounting fixture was designed and fabricated to meet compatibility requirements of the flight spare hardware. A list of the critical components of the system includes:

1. ZETEC MIZ-27-SI eddy current Tester, ECN#3022157
2. Dell Laptop Computer
3. Four COPV eddy current probes, custom wound
4. Four Interface Boxes with matching circuitry
5. Four eddy current sensor mounts
6. Timing Trigger Circuit

Engineering drawings of the COPV eddy current probe and Eddy current sensor mount designs are given in Figs. 1 and 2. All dimensions are in inches.

A 20 foot cable connects each of the sensors to the back of the eddy current instrument. The corresponding channel number on the Miz-27 displays the output for each sensor. Cables are labeled at all ends. During testing a 20 kHz, 5.0V drive is supplied to the test coils and a 40dB gain is applied across the measurement bridge. A 34dB gain is used on the trigger channel. All system settings are stored in nonvolatile memory on the Miz-27 instrument. Fig. 3 show the front panel boot up screen of the eddy current instrument. The system is configured to display sensors 1-4 on ‘Page(1)’,

and trigger channel 5 along with sensors 2,3 and 4 on 'Page(2)'. Labeled buttons on the bottom of the instrument are used to change the page being viewed in the display. During data acquisition all five channels of data are stored to mass storage at a rate of 100 Hz.

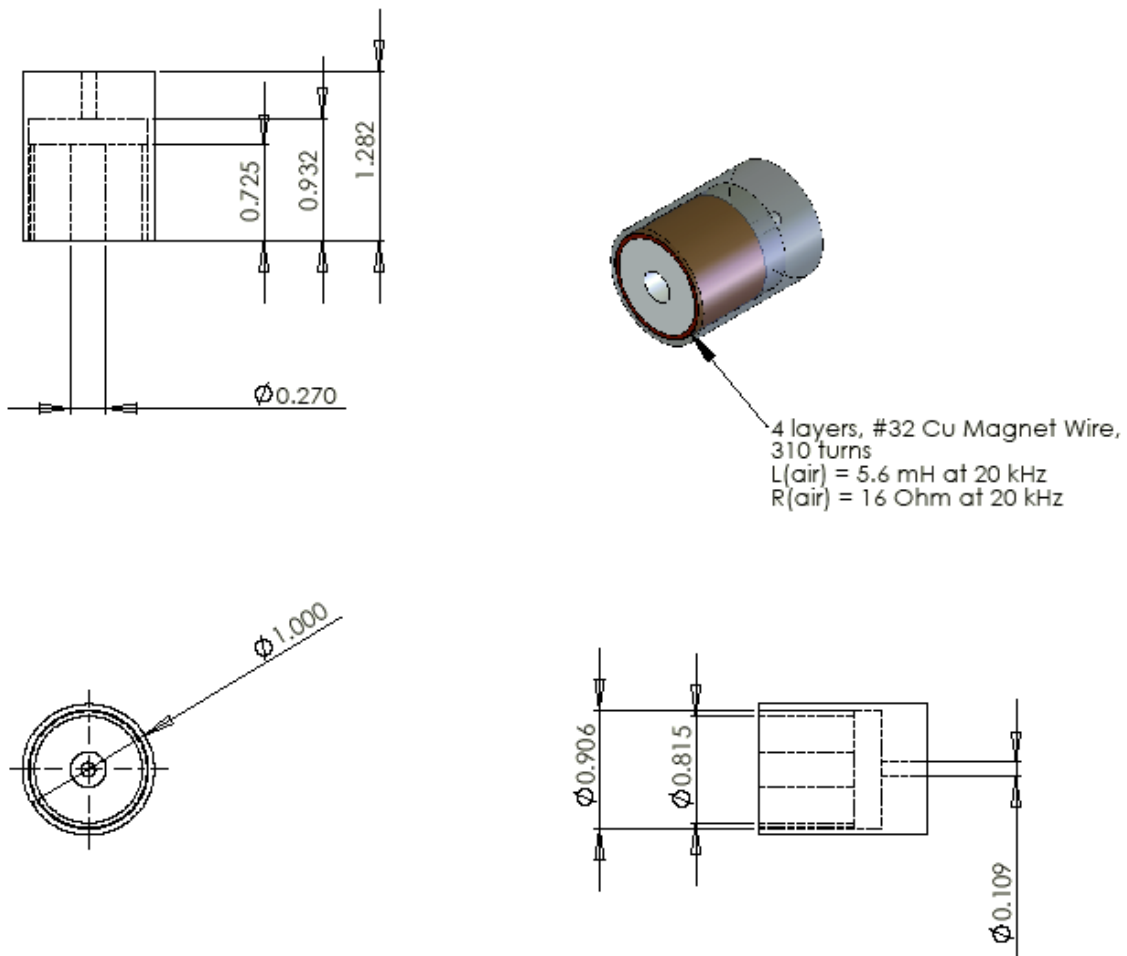
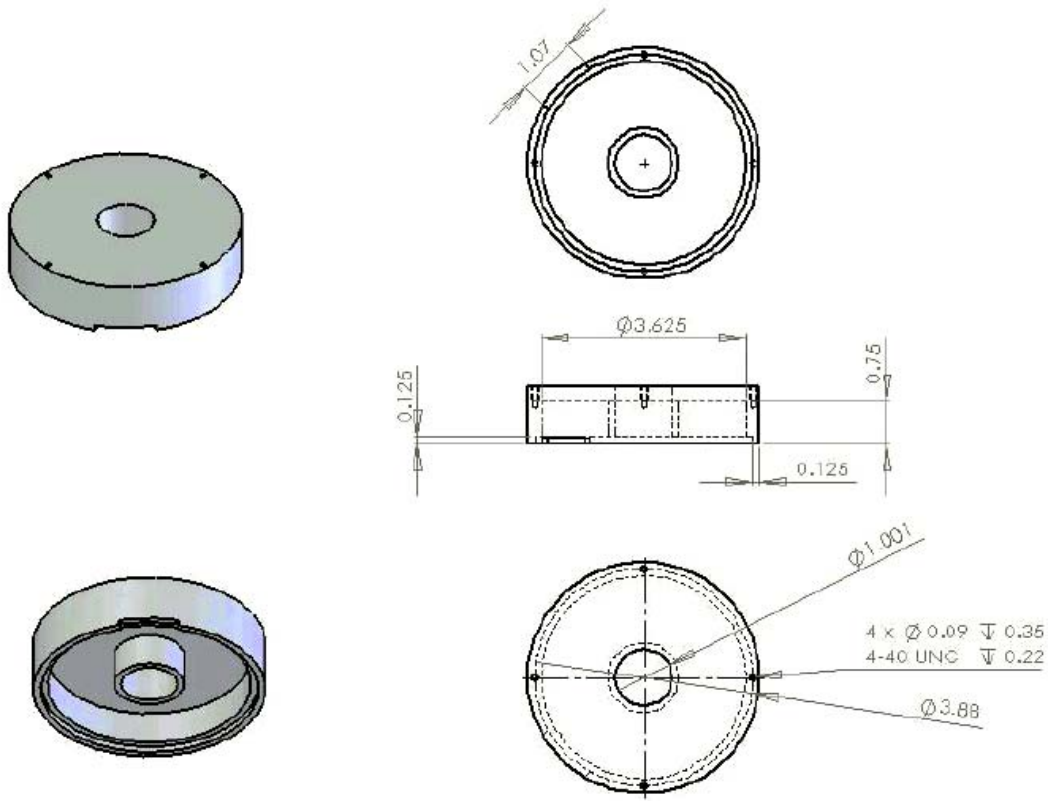

Fig. 1. Eddy current sensor design.



Manufactured From Black Delrin, McMaster Car Part #9986K22
 Mass = 4.5 Oz, 6 Oz with probe installed
 Buna-N and Cork composite shim, 1/16" thick (McMater Car Part # 96165K32),
 placed between part and COPV in three locations to form stable base.

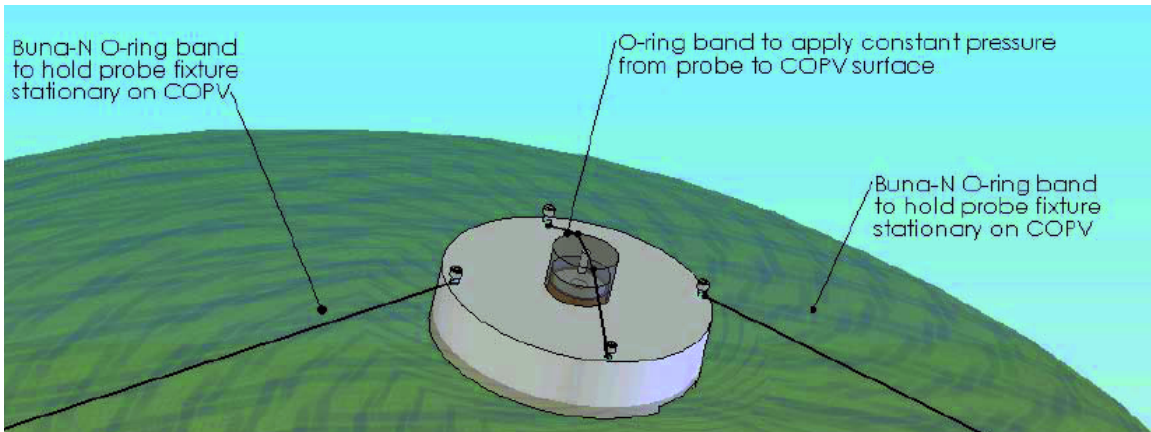

Fig. 2. Eddy current probe mount and sensor mounting configuration.

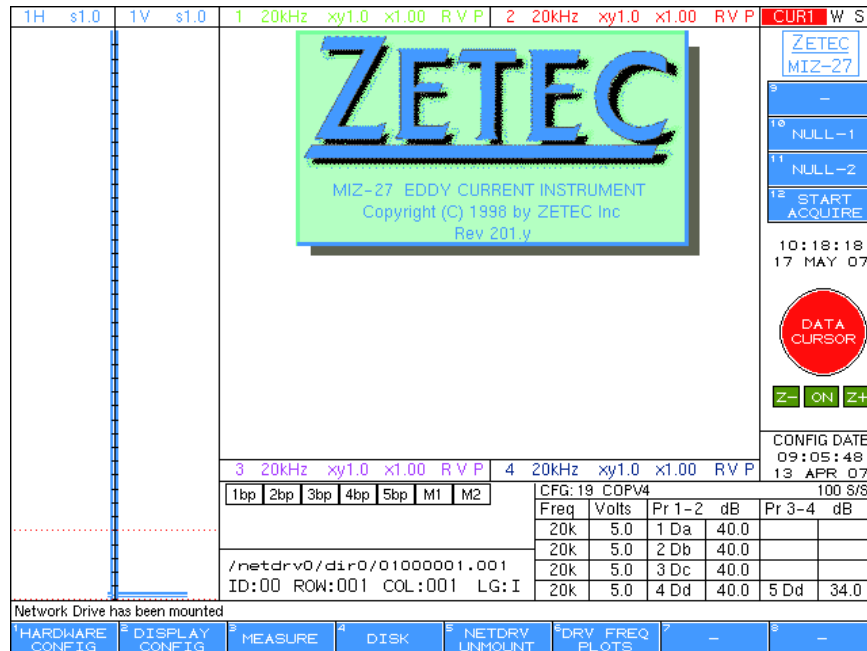

Fig. 3. Front panel of eddy current instrument after startup.

Laboratory Sensor Calibration

The system is calibrated such that overwrap thickness changes produce a vertical signal response, and designed such that changes in the liner thickness produce an orthogonal, horizontal, output voltage. The calibration factors for each of the sensors were determined in the laboratory by recording the sensor response for known changes in lift-off and metal thickness near the 40in diameter COPV nominal values. Table 1 displays the calibration data for each of the four sensors. The lift-off distance, simulating the thickness of the Kevlar overwrap, was varied through the use of non-

Table 1. Calibration Data for Eddy Current Sensors.

| Lift-off (in) | Titanium (in) | S1_H (Volts) | S1_V (Volts) | S2_H (Volts) | S2_V (Volts) | S3_H (Volts) | S3_V (Volts) | S4_H (Volts) | S4_V (Volts) |
|---------------|---------------|--------------|--------------|--------------|--------------|--------------|--------------|--------------|--------------|
| 0.855 | 0.112 | | -0.959 | | -1.004 | | -0.931 | | -0.937 |
| 0.85 | 0.112 | -0.096 | -1.628 | -0.01 | -1.525 | -0.113 | -1.55 | 0.0429 | -1.57 |
| 0.845 | 0.112 | | -2.239 | | -2.15 | | -2.181 | | -2.187 |
| 0.84 | 0.112 | | -2.875 | | -2.67 | | -2.816 | | -2.833 |
| 0.835 | 0.112 | | -3.551 | | -3.454 | | -3.477 | | -3.451 |
| 0.83 | 0.112 | | -4.247 | | -4.169 | | -4.17 | | -4.15 |
| 0.825 | 0.112 | | -4.869 | | -4.839 | | -4.89 | | -4.826 |
| 0.82 | 0.112 | | -5.554 | | -5.53 | | -5.558 | | -5.547 |
| 0.815 | 0.112 | | -6.237 | | -6.193 | | -6.25 | | -6.187 |
| 0.85 | 0.095 | 1.999 | | 2.114 | | 2.023 | | 2.053 | |

conducting spacers. The titanium thickness was varied by either placing the probe over a single titanium plate of 0.095” or combining two plates with a total thickness of 0.112”.

A plot of the vertical output voltage of the sensors versus changing stand-off (simulating changes in overwrap thickness) for each of the sensors is given in Fig. 4. A linear fit to the data is also shown in the plot, with the results indicating a sensitivity of approximately 130 mV/mil for each of the sensors.

Sensor Installation and Field Calibration

Following testing and calibration, the eddy current system was transferred to NASA White Sands Test Facility for sensor installation, field calibration, and testing. Eddy current sensors were mounted using the probe mount shown in Fig. 2. A circumferential O-ring was used to hold the probe mount stationary on the COPV and a second O-ring fastened to the probe mount maintained a constant force on the eddy current sensor normal to the COPV surface. The mounting location of the sensors on the COPV is described in WSTF-TP-1085-07.A, “Space Shuttle Orbiter Main Propulsion System P/N MC282-0082-0101 S/N 002 and Orbital Maneuvering System P/N MC282-0082-001 S/N 027 COPV Health Assessment” [1].

As shown in Fig. 2, a small access notch was machined into the probe mount to enable a field calibration of the sensors to changes in the overwrap thickness. Nonconducting shims of 5, 10, 15 and 20 mils were sequentially inserted through this notch and placed between the probe and the outer layer of the COPV overwrap. Fig. 5 displays the field calibration data acquired for sensor 3 mounted on COPV SN002. A large spike in the data is observed as the probe is pulled away from the surface to enable each of the four successive shims to be placed between the probe and the COPV. Each shim was kept in place for approximately 10 seconds before being pulled out. The

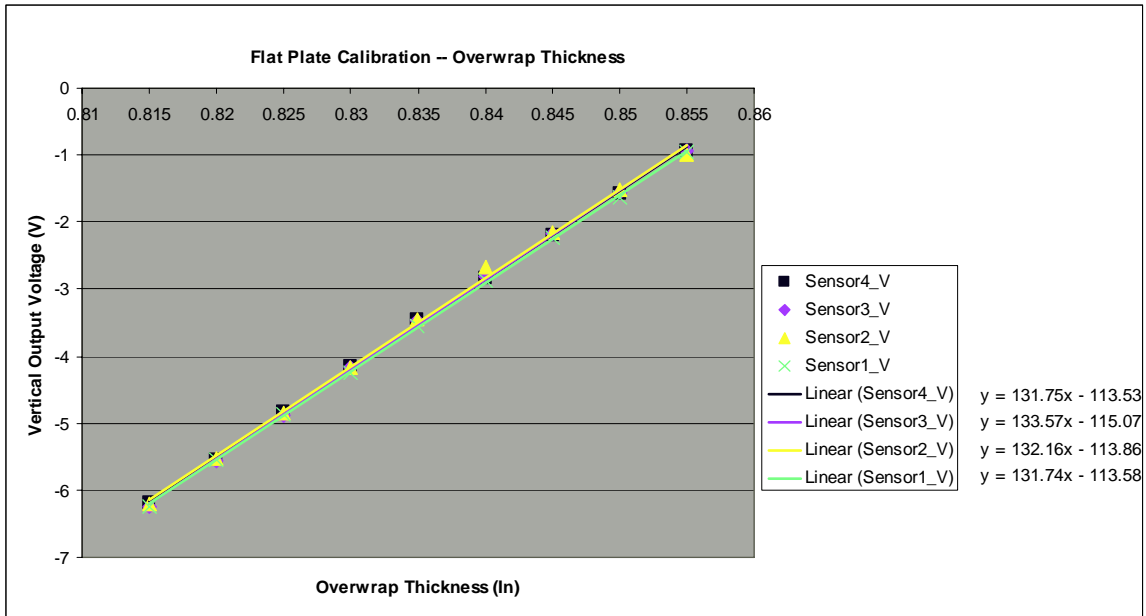

Fig. 4. Laboratory calibration data for system sensitivity to overwrap thickness changes.

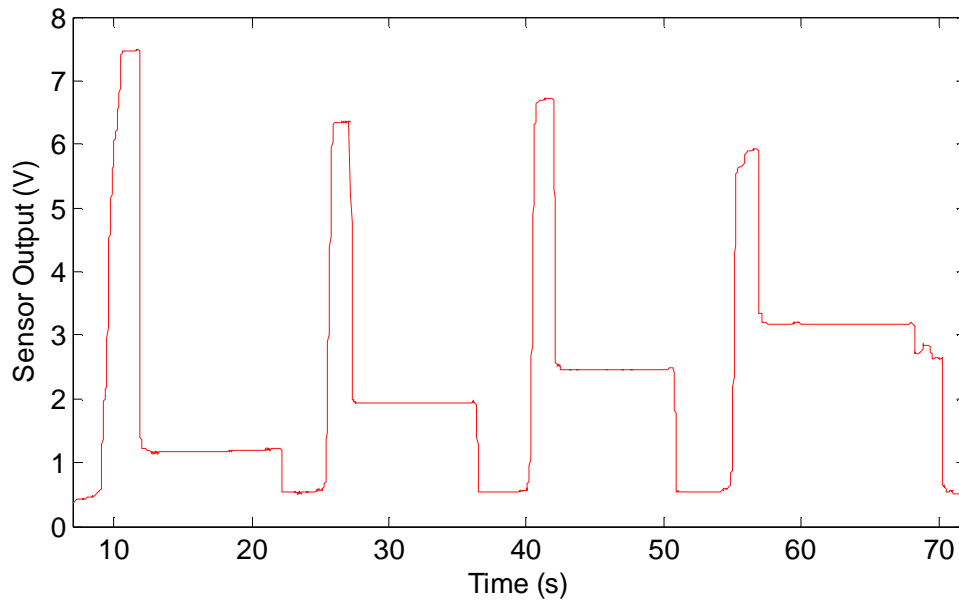

Fig. 5. Field calibration data for sensor 3 mounted on COPV SN002. Data corresponds to 5,10,15 and 20 mil shims placed between COPV and sensor at approximately 10, 25, 40, and 55 seconds.

resulting drop in voltage for each shim thickness was measured and the calibration factor determined by fitting a straight line to the output voltage versus shim thickness plots. Table 2 lists the calculated calibration factors for each sensor mounted on both COPV SNs 002 and 027.

Table2. Sensor Output versus Coating Thickness

| | Sensor1 | Sensor2 | Sensor3 | Sensor4 |
|---------------|---------|---------|---------|---------|
| SN002(mV/mil) | 145 | 130 | 133 | 129 |
| SN027(mV/mil) | 149 | 144 | 129 | 156 |

Test Results for SN002 and SN027 Pressurizations

Health assessment pressurization runs on flight spare COPV SNs 002 and 027 were performed from ambient pressure to approximately 4000 psi using a hydraulic pressurization according to the White Sands Test Facility test plan [1]. During each pressurization run, eddy current data was acquired and synchronized with pressurization data. Previously calculated calibration data was then applied to convert the measured sensor voltages into thickness changes of the liner and overwrap.

Figs. 6 and 8 display the measured overwrap thickness changes and pressurization as a function of time for COPV SNs 002 and 027 respectively. Figs. 7 and 9 display the overwrap thickness changes versus pressurization for these data sets. Both sets of data

have been corrected for an assumed linear drift of the eddy current sensor data between the trigger signal and the end of the pressure cycle. A second correction has also been applied to account for the effect of cyclic temperature variations on the eddy current sensor response. The coefficients for this second correction were determined from the response of the trigger channel, sensor 5. This channel consisted of an equivalent eddy current sensor not in contact with the COPV. Upon initiation of the pressurization cycle a momentary change in impedance is applied to sensor 5 through the use of a timing circuit. In this circuit, a 5V, 25mA signal is used to switch in an extra load to the matching network to produce a timing mark in the data file. Post processing of the data is used to identify this signal and synchronize eddy current data with pressurization data. As the sensor is not in contact with the COPV, data acquired during the remainder of the test can be analyzed to remove environmental effects from the data not associated with changes in the COPV.

The eddy current sensor data is seen to correlate very well with the pressurization data, with all sensors showing a similar response. For COPV SN002, the thickness change at maximum pressure is slightly over 5 mils for sensors 1 and 3, and about 6 mils for sensors 2 and 4. The data recorded for SN027 shows maximum thickness changes near 5 mils for each sensor. The overwrap thickness change versus pressure plots, Figs. 7 and 9, display a linear response with no apparent hysteresis in the data. Although temperature effects have been filtered as described above, a slight cyclic periodicity to the data can still be observed and is presumed to be due to temperature change artifacts.

Figs. 10 and 11 display the measured change in liner thickness versus pressure for COPV SNs 002 and 027 respectively. The much smaller thickness changes, < 1 mil, result in a lower signal to noise ratio for these measurements. In addition, the processing steps used to remove the cyclic temperature variations were seen to increase the high frequency noise on the horizontal (liner thickness) channel of the eddy current instrument. A clear trend of decreasing liner thickness with increasing pressure is nonetheless observed in the data for each vessel.

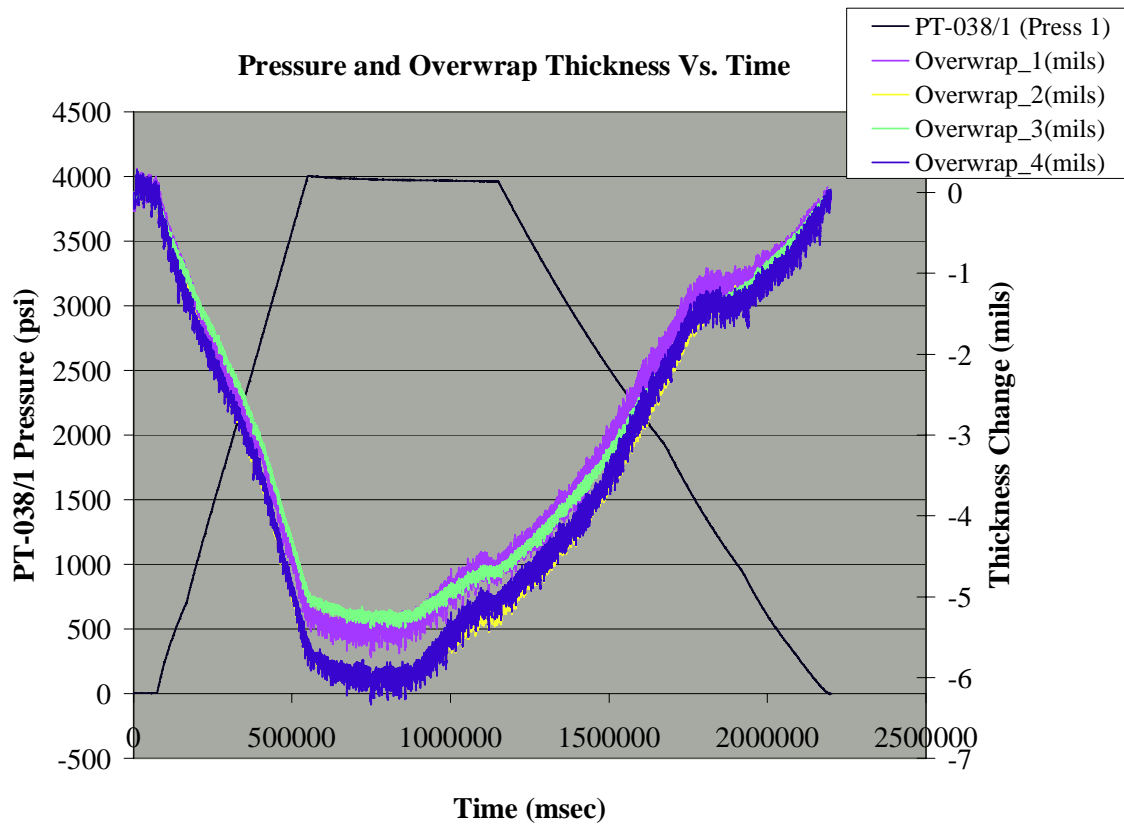

Fig. 6. Measured pressure and overwrap thickness change for COPV SN002.

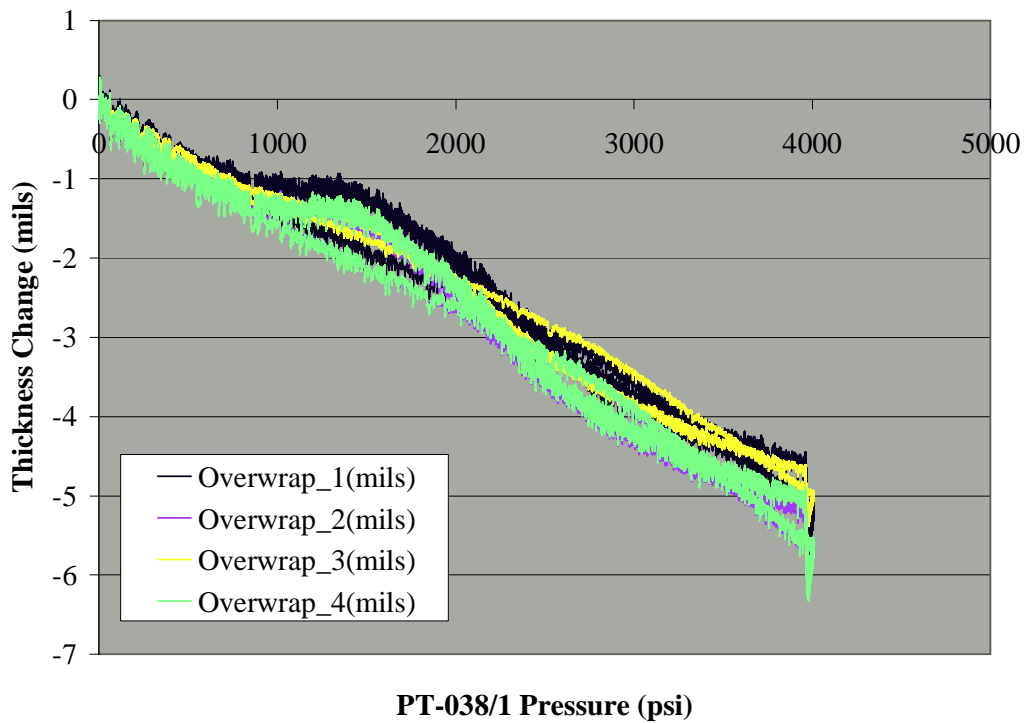

Fig. 7. COPV SN002 overwrap thickness change versus pressure.

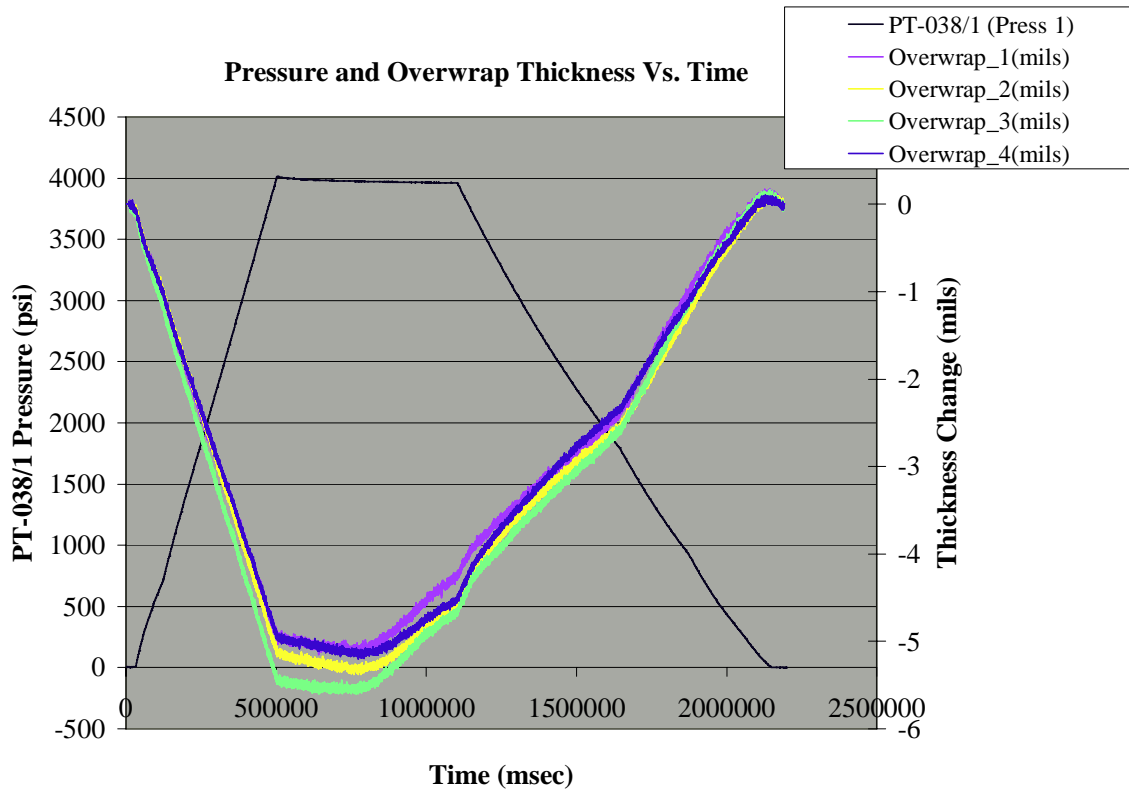

Fig. 8. Measured pressure and overwrap thickness change for COPV SN027.

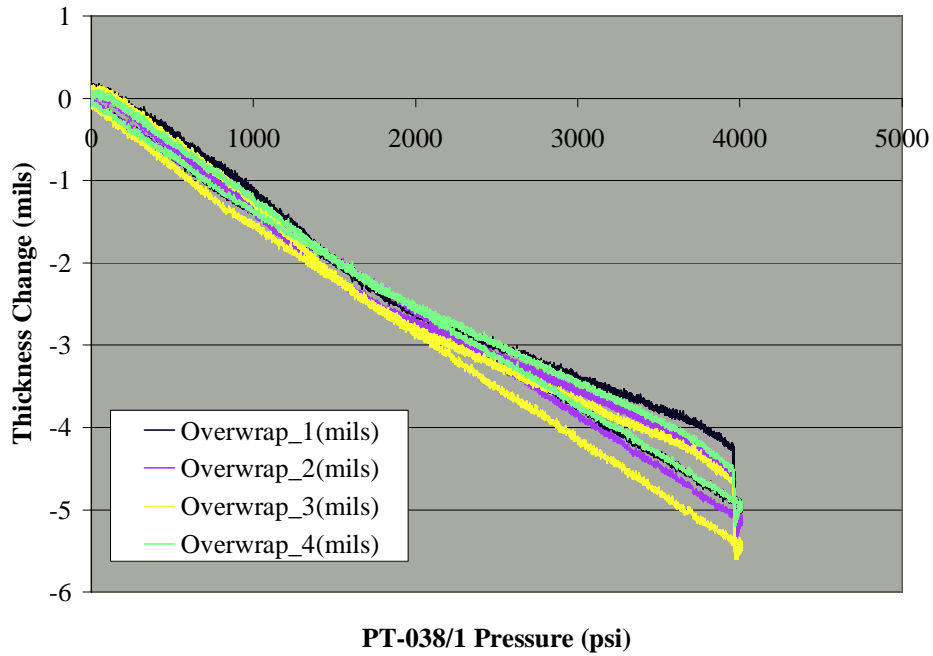

Fig. 9. COPV SN027 overwrap thickness change versus pressure.

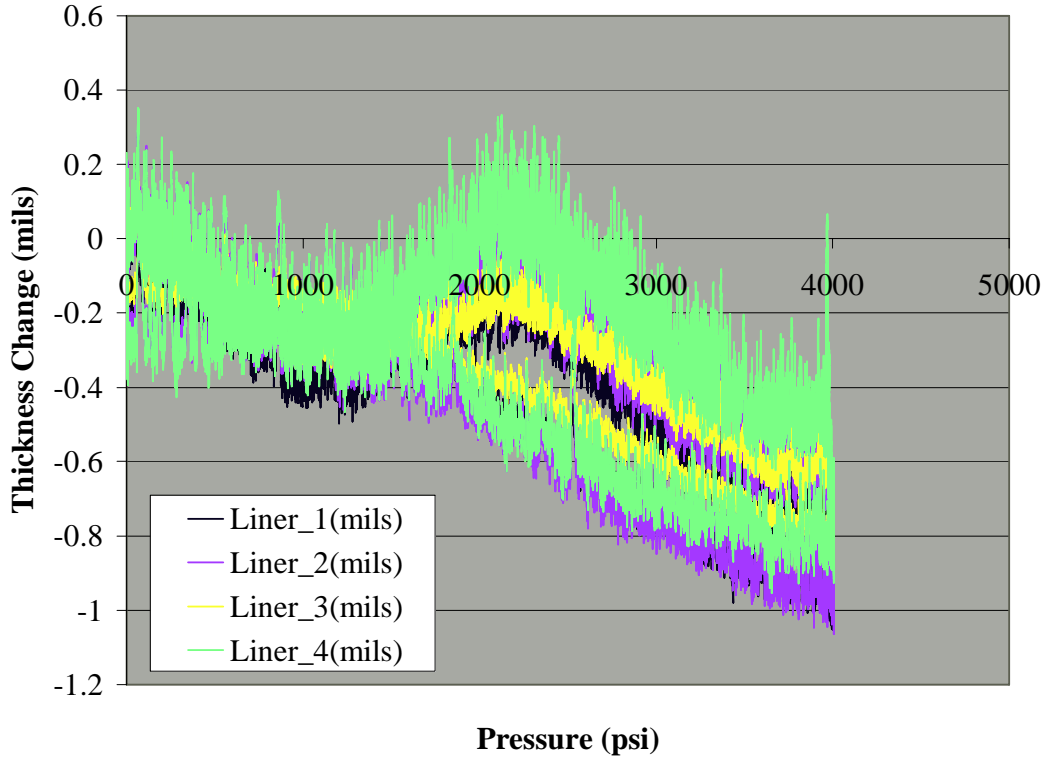

Fig. 10. COPV SN002 liner thickness change versus pressure.

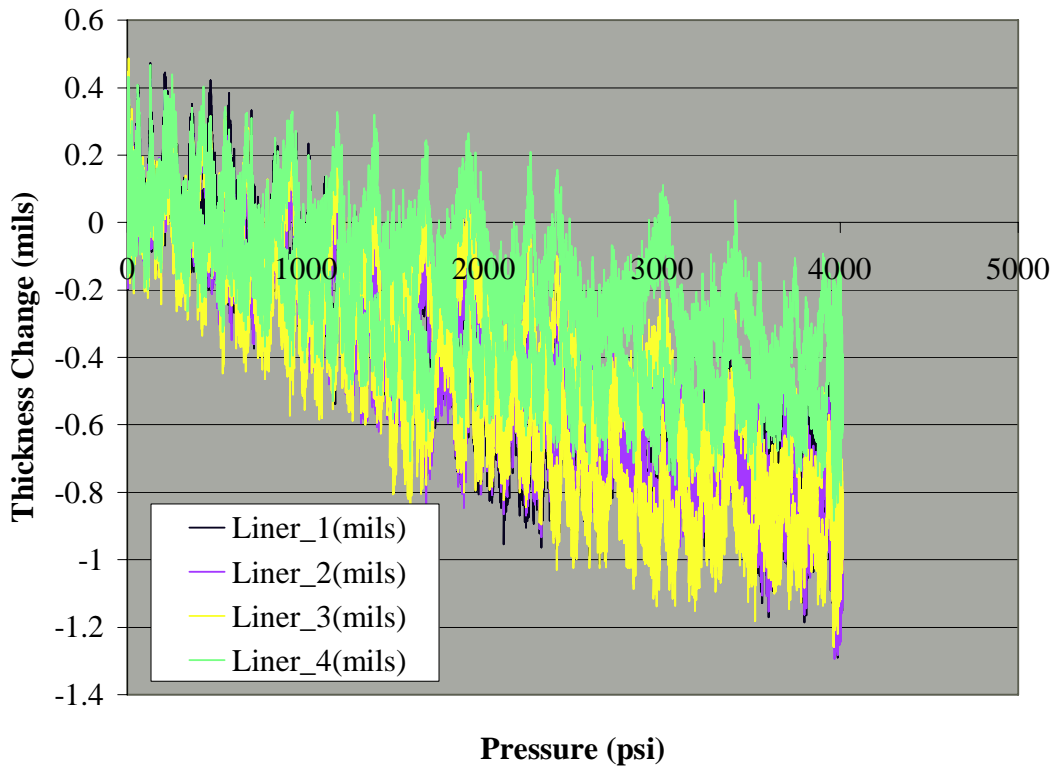

Fig. 11. COPV SN027 liner thickness change versus pressure.

Summary

As a part of the health assessment of flight spare COPVs SN002 and SN027, eddy current measurements of the overwrap and liner thickness changes as a function of pressurization were requested. In response to this request, a measurement system was designed using a commercial impedance plane eddy current instrument with custom wound eddy current sensors. A new probe mounting technique compatible with the flight spare hardware was also designed and probe mounts fabricated. Calibration of the sensors for changes in overwrap and liner thicknesses near the nominal values for 40in COPVs was performed in the laboratory. Subsequent recalibration of the sensors for overwrap thickness changes in the mounting configuration on the flight spare vessels was performed and found to be consistent with laboratory calibration. Eddy current data acquired during pressurization of COPV SN002 and SN027 found overwrap thickness changes in the range of 5-6 mils. Liner thickness changes were measured at approximately 0.5 – 1.0 mils. This data is consistent with previous measurements on other COPV vessels [3,4]. Data was transferred to the COPV analysis team and no concerns were raised on either the magnitude or linearity of the obtained values.

References

1. Test Plan, "Space Shuttle Orbiter Main Propulsion System P/N MC282-0082-0101 S/N 002 and Orbital Maneuvering System P/N MC282-0082-0001 S/N 027 COPV Health Assessment," WSTF_TP_1085-07.A, 4/16/2007.
2. J. Thesken, P. Murthy, and L. Phoenix, "Composite Overwrap Vessels Mechanics and Stress Rupture Lifting Philosophy," *48th AIAA ASME ASCE AHS ASC Structures, Structural Dynamics and Materials Conference*, NASA DOC ID 20070022369, 2007.
3. Investigative Report, "Nondestructive Evaluation and Destructive Analysis of Kevlar/epoxy COPV Stress Rupture FY 2006 Annual Report," in work.
4. P. Williams, B. Wincheski, and J. Simpson, "Eddy Current Inspection of Composite Overwrap Pressure Vessels." Presented at *2007 Review of Progress in Quantitative NDE*, Golden CO., 7/23/2007.
5. M. Leifeste, "Interrelationship of Nondestructive Evaluation Methodologies Applied to Testing of Composite Overwrapped Pressure Vessels," *Second IAASS Conference – Space Safety in a Global World*, NASA Doc ID 20070020334, 2007.
6. N. Greene et al, "Testing of Full Scale Flight Qualified Kevlar Composite Overwrapped Pressure Vessels," *48th AIAA ASME ASCE AHS ASC Structures, Structural Dynamics and Materials Conference*, NASA DOC ID 20070011614, 2007.

REPORT DOCUMENTATION PAGE

*Form Approved
OMB No. 0704-0188*

The public reporting burden for this collection of information is estimated to average 1 hour per response, including the time for reviewing instructions, searching existing data sources, gathering and maintaining the data needed, and completing and reviewing the collection of information. Send comments regarding this burden estimate or any other aspect of this collection of information, including suggestions for reducing this burden, to Department of Defense, Washington Headquarters Services, Directorate for Information Operations and Reports (0704-0188), 1215 Jefferson Davis Highway, Suite 1204, Arlington, VA 22202-4302. Respondents should be aware that notwithstanding any other provision of law, no person shall be subject to any penalty for failing to comply with a collection of information if it does not display a currently valid OMB control number.
PLEASE DO NOT RETURN YOUR FORM TO THE ABOVE ADDRESS.

| | | | | | |
|--|--------------------|---|-----------------------------------|--|--|
| 1. REPORT DATE (DD-MM-YYYY) 01-01 - 2008 | | 2. REPORT TYPE Technical Memorandum | | 3. DATES COVERED (From - To) | |
| 4. TITLE AND SUBTITLE Eddy Current COPV Overwrap and Liner Thickness Measurement System and Data Analysis for 40-Inch Kevlar COPVs SN002 and SN027 | | | | 5a. CONTRACT NUMBER | |
| | | | | 5b. GRANT NUMBER | |
| | | | | 5c. PROGRAM ELEMENT NUMBER | |
| 6. AUTHOR(S) Wincheski, Russell (Buzz) A. | | | | 5d. PROJECT NUMBER | |
| | | | | 5e. TASK NUMBER | |
| | | | | 5f. WORK UNIT NUMBER 377816.06.02.03.05 | |
| 7. PERFORMING ORGANIZATION NAME(S) AND ADDRESS(ES) NASA Langley Research Center Hampton, VA 23681-2199 | | | | 8. PERFORMING ORGANIZATION REPORT NUMBER L-19427 | |
| 9. SPONSORING/MONITORING AGENCY NAME(S) AND ADDRESS(ES) National Aeronautics and Space Administration Washington, DC 20546-0001 | | | | 10. SPONSOR/MONITOR'S ACRONYM(S) NASA | |
| | | | | 11. SPONSOR/MONITOR'S REPORT NUMBER(S) NASA/TM-2008-215105 | |
| 12. DISTRIBUTION/AVAILABILITY STATEMENT Unclassified - Unlimited Subject Category 26 Availability: NASA CASI (301) 621-0390 | | | | | |
| 13. SUPPLEMENTARY NOTES An electronic version can be found at http://ntrs.nasa.gov | | | | | |
| 14. ABSTRACT As part of the health assessment of flight spare 40in diameter Kevlar composite overwrapped pressure vessels (COPVs) SN002 and SN027 an eddy current characterization of the composite and liner thickness change during pressurization was requested under WSTF-TP-1085-07.A, "Space Shuttle Orbiter Main Propulsion System P/N MC282-0082-0101 S/N 002 and Orbital Maneuvering System P/N MC282-0082-001 S/N 027 COPV Health Assessment." The through the thickness strains have been determined to be an important parameter in the analysis of the reliability and likelihood of stress rupture failure. Eddy current techniques provide a means to measure these thicknesses changes based upon the change in impedance of an eddy current sensor mounted on the exterior of the vessel. Careful probe and technique design have resulted in the capability to independently measure the liner and overwrap thickness changes to better than +/- 0.0005 in. at each sensor location. Descriptions of the inspection system and test results are discussed. | | | | | |
| 15. SUBJECT TERMS COPV; Eddy Current; Liner; Overwrap; Thickness measurement | | | | | |
| 16. SECURITY CLASSIFICATION OF: | | | 17. LIMITATION OF ABSTRACT | 18. NUMBER OF PAGES | 19a. NAME OF RESPONSIBLE PERSON |
| a. REPORT | b. ABSTRACT | c. THIS PAGE | | | STI Help Desk (email: help@sti.nasa.gov) |
| U | U | U | UU | 16 | 19b. TELEPHONE NUMBER (Include area code) (301) 621-0390 |