

20V, 40 Ah Lithium Ion Polymer Battery for the Spacesuit

by

Eric Darcy and Monique Wilburn,
NASA-JSC

Dan Hall, Lockheed Martin

Peter Roth, Sandia National Labs

Sankar Das Gupta, Jim Jacobs, Rakesh
Bhola, Gordan Milicic, and Dave
Vandemeer, Electrovaya





Contents

- Objectives
- Background
- Main Project Requirements
- Critical Design Solution
 - LIB
 - LIB Charger
- Engineering Verification Status
 - Vacuum cycle life testing
 - Calorimetry
- Safety Strategy & Abuse Tolerance
- Summary & Schedule

Objective: Consider a new battery design for EMU

- Current Ag-Zn Increased Capacity Battery (ICB) limitations:
 - **Wetlife/Capacity**- Capable of only 300 day wet life with a 12 cycle capability
 - **Cycling** - Requires un-interrupted periodic cycling on-orbit to maintain performance
 - **Cost** - With activation, cost >\$55K each, or \$6.6 M every 10 years, which is very expensive
 - **Activation** - Delivered to USA dry and requires a 5-week activation process
 - **Relief Valves** - Has low pressure cell relief valves that have a leakage history on-orbit (twice)
 - **Obsolescence** - Ag-Zn electrochemistry has very few vendors and high obsolescence risk
 - **Rest time** - Requires 4 hour rest time between discharge and charge

- Redesign the current EMU battery to:
 - **Wetlife** - Improved on orbit capacity (5 years, 150 cycles)
 - **Cycling** – None required, reduced crew ops on-orbit
 - **Cost** - Reduced life cycle cost (save \$4.2M every 10 years)
 - **Activation** – No activation required (additional savings)
 - **Relief Valves** - Non-spillable due to sealed design
 - **Obsolescence** – Dozens of vendors worldwide
 - **Rest time** – None required
 - **Additional Benefits:**
 - Reduce up/down mass requirements
 - Drop in replacement for Increased Capacity Battery (ICB)
 - Maintain compatibility with Shuttle Air Lock Charger
 - Reduce # of Critical Failures Modes from 4 to 2

**Current EMU
Increased Capacity Battery (ICB)**



Electrovaya Li-ion Battery Manufacturing Plant

Mississauga, Canada

- Commercialized Powerpad Li-Ion Batteries
 - Carbon Graphite anode
 - LiCoO_2 cathode
 - Polymer impregnated
 - Laminate pouch enclosure
- Mfg. Plant – 156,000 Sq Ft on 15 acres
- Present Capacity: 5 MWh/month
- Added Aerospace cell line for this effort





Project Top Level Requirements

- Lithium Ion Battery (LIB) Requirements
 - Capacity at End-of-Life (EOL) (identical to that for ICB)
 - 26.6 Ah for EMU-PLSS with 12A, <5s start-up pulse
 - Voltage (16 to 21V)
 - Service life (5 yrs from delivery to NASA, vs 300 day for ICB)
 - Cycle Life (150 cycles vs 12 cycles for ICB)
 - Charge Stand
 - (600 days at 100% SOC, remaining time at <50%, all at 20°C)
 - Mass (<7.05 kg or 15.5 lbs)
 - ICB is 14.7 lbs
 - Volume (Do not exceed interface requirements)
 - Provide additional connector for new portable flight charger and GSE charger
 - Add temperature sense leads at additional connector
 - Environmental Performance
 - Meet capacity and life with 150 EVAs performed at worst case hot or cold conditions
 - Existing Charger Compatibility
 - Shuttle Air Lock Charger used CV mode to 21.8V (4.36V per cell) with 1.55A limit
 - Manual charge termination by the crew is acceptable

LIB Interfaces

- Power
 - Receptacle J1 mating to the PLSS is MS3424E7-50S
 - Receptacle J2 mating to the LIB Charger and GSE is EGG.4B.310.CLL
- Physical
 - Shall not exceed envelope of interface control document
 - Same locking interface as ICB
- Thermal
 - Shall generate < 10 W average heat during discharge
- Pressure
 - None

EXTRAVEHICULAR MOBILITY UNIT

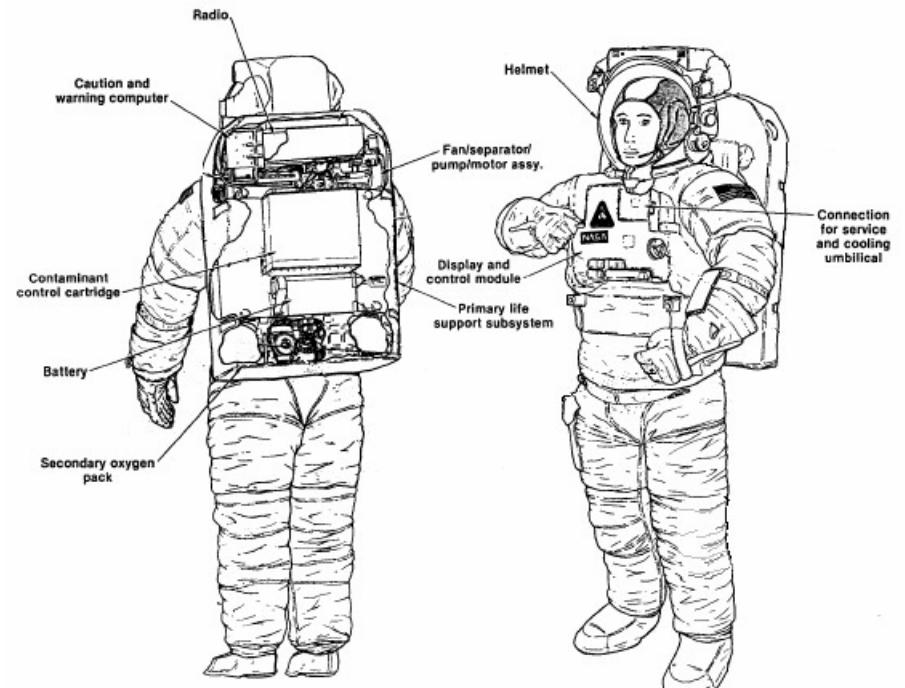

Design Solution Successfully Fit Checked



Expanded View of the LIB

- Aluminum housing and lid ass'y
- Discharge and Charge connectors
- 20V, 40Ah, 15.1 lbs
- 5 Cell Modules in series
- 1 Cell Module = 5 cells in parallel

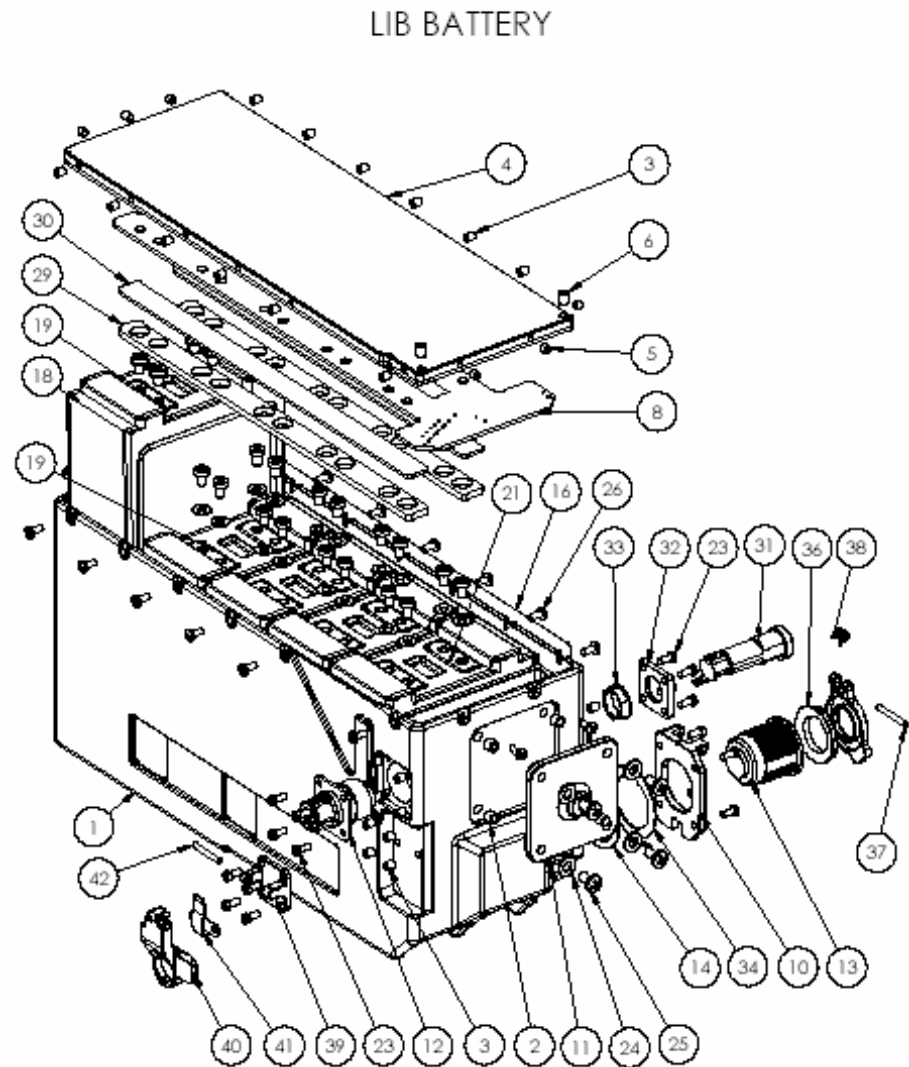

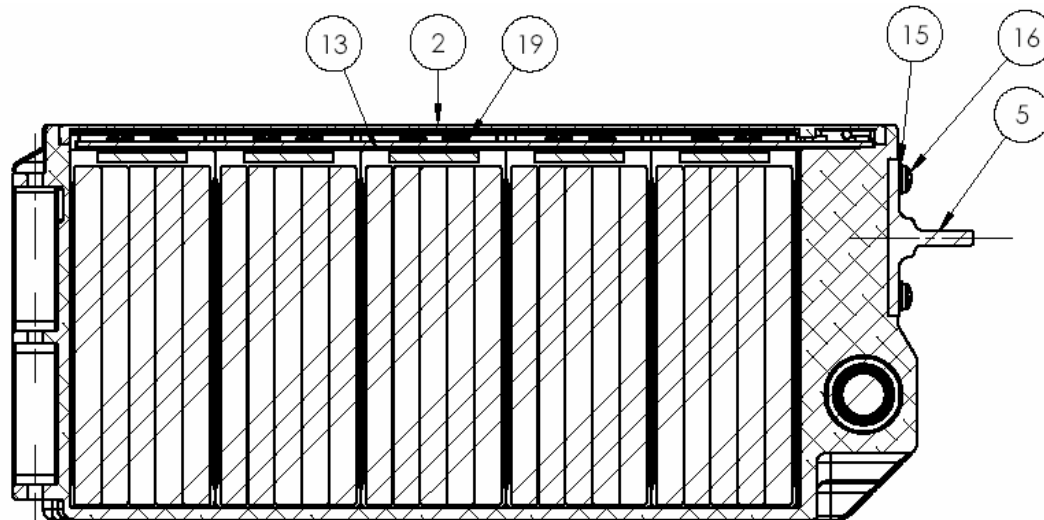

Top View



Profile View

PCB used to tie cell modules in series

Cell Module

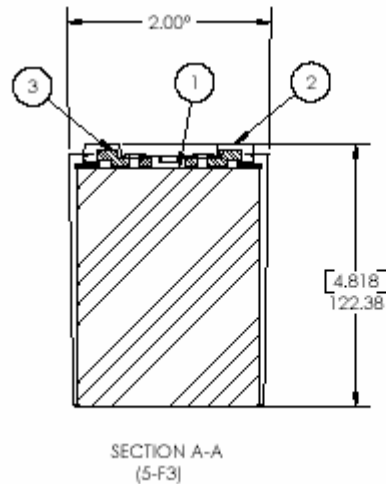
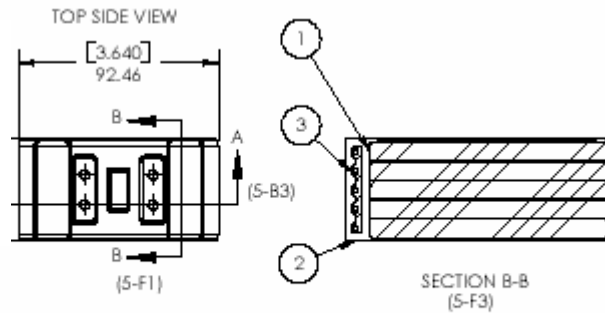
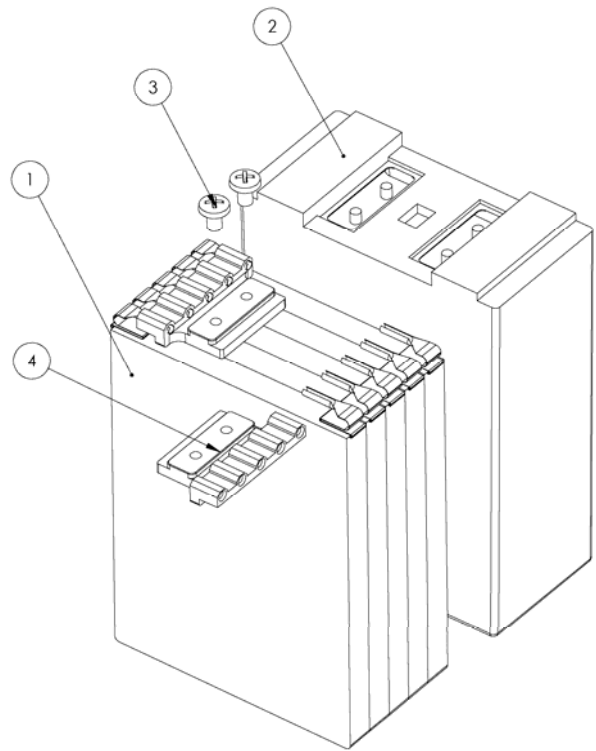

Outer bag, omitted for clarity, encloses the 5 cells
 Sacrificial electrolyte stored in plastic bag next to wide face of 5th cell

NASA LIB Cell

Mass ~ 168 g

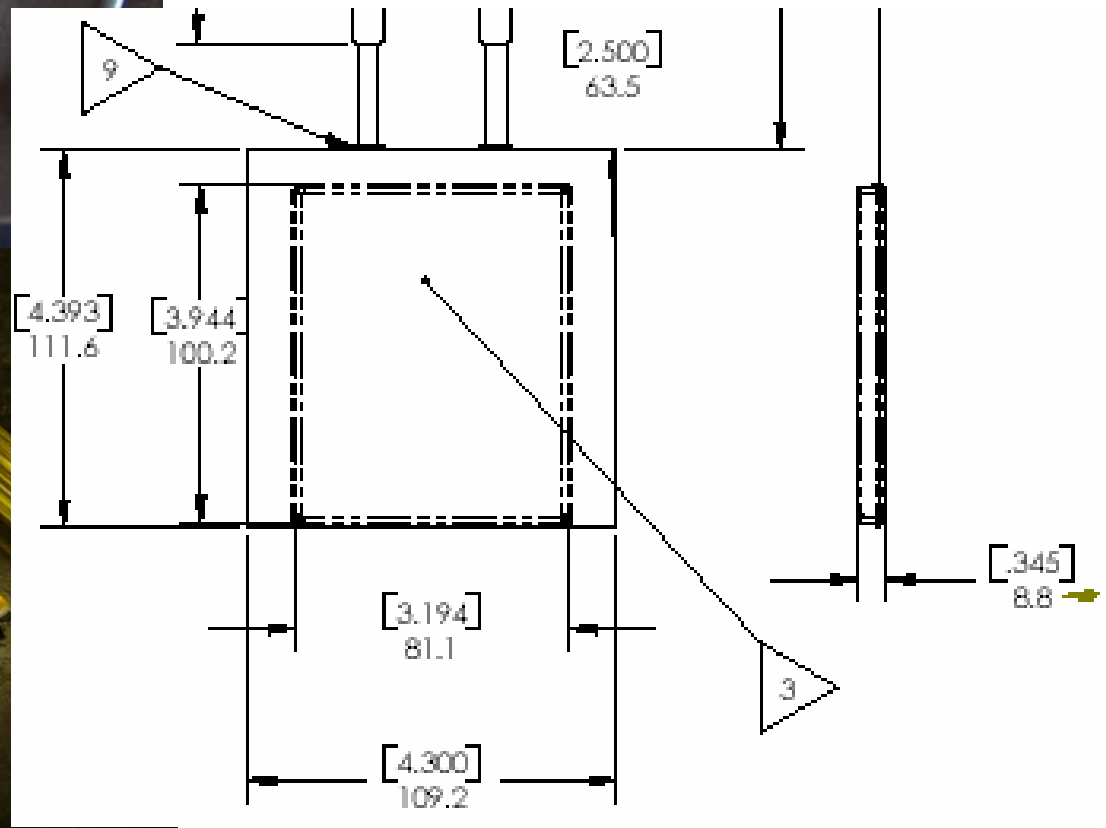
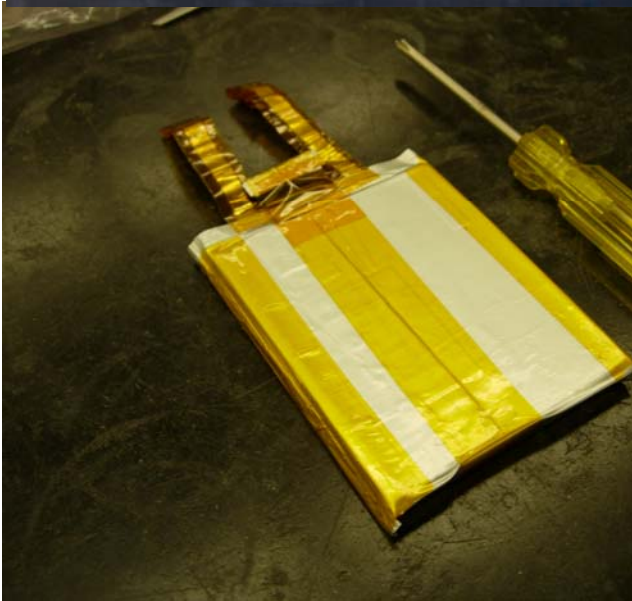



Temperature Effect on Capacity (C/10 Discharge)

Discharge capacity vs voltage @ different temperatures

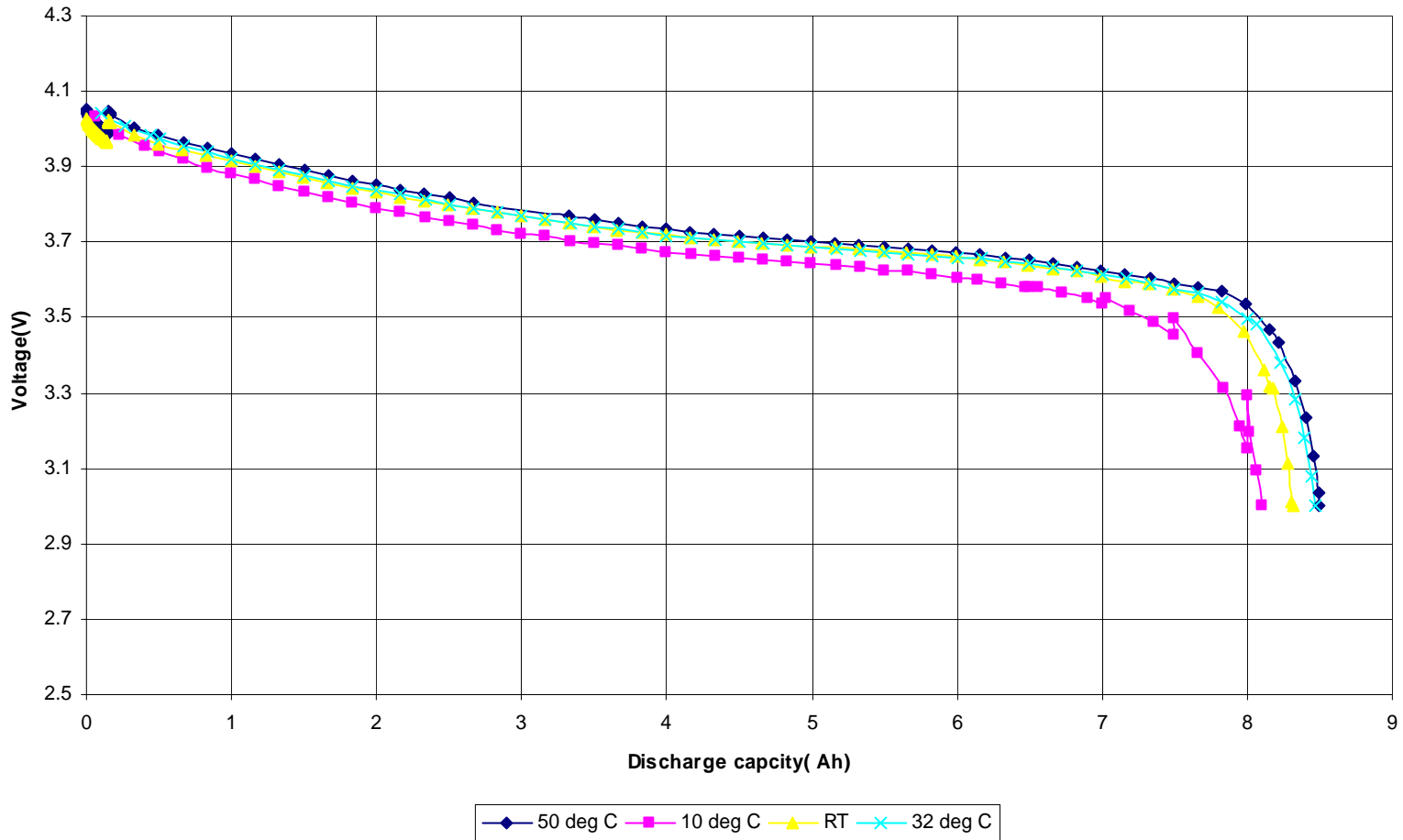

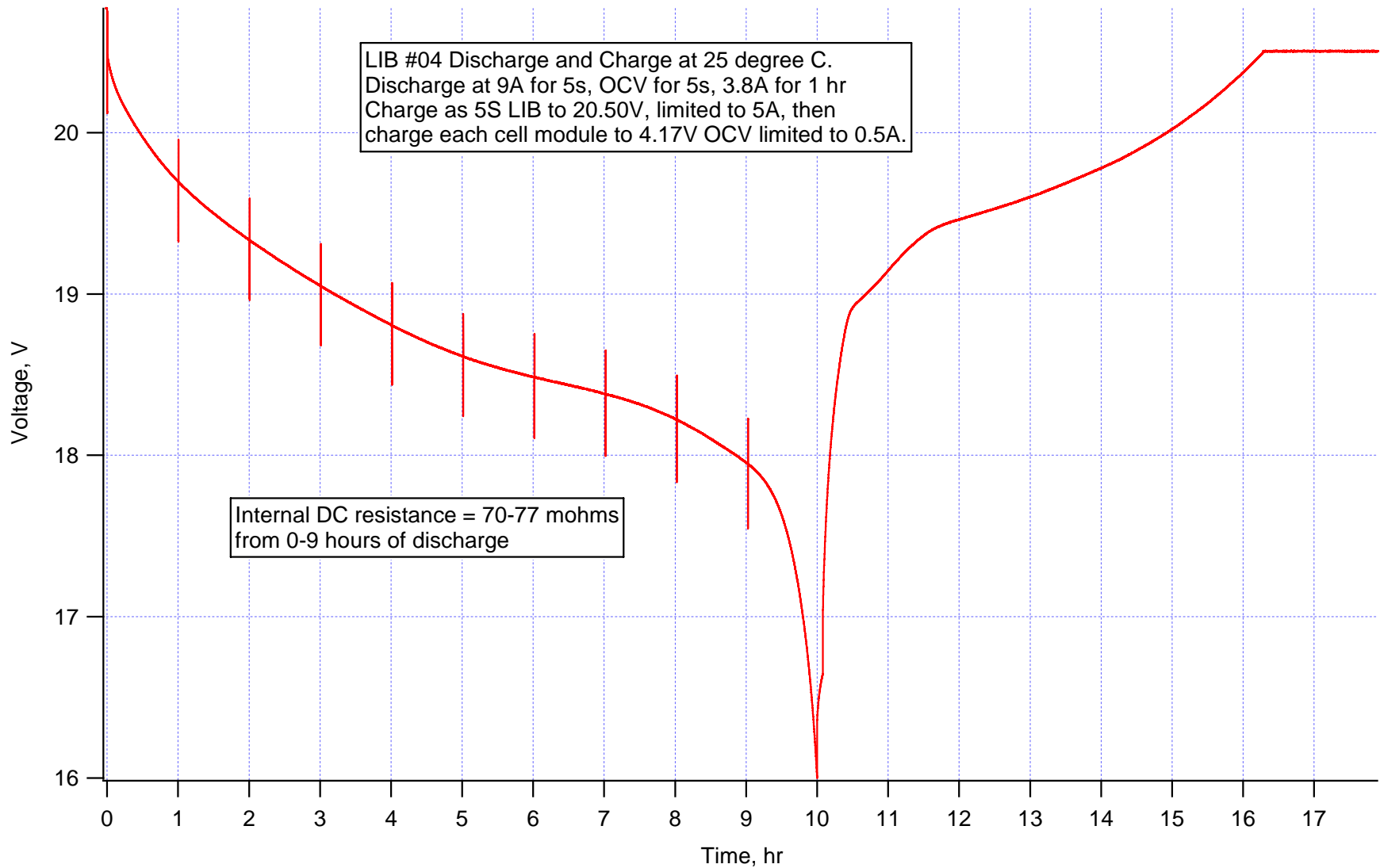



DC internal resistance vs. State-of-Charge

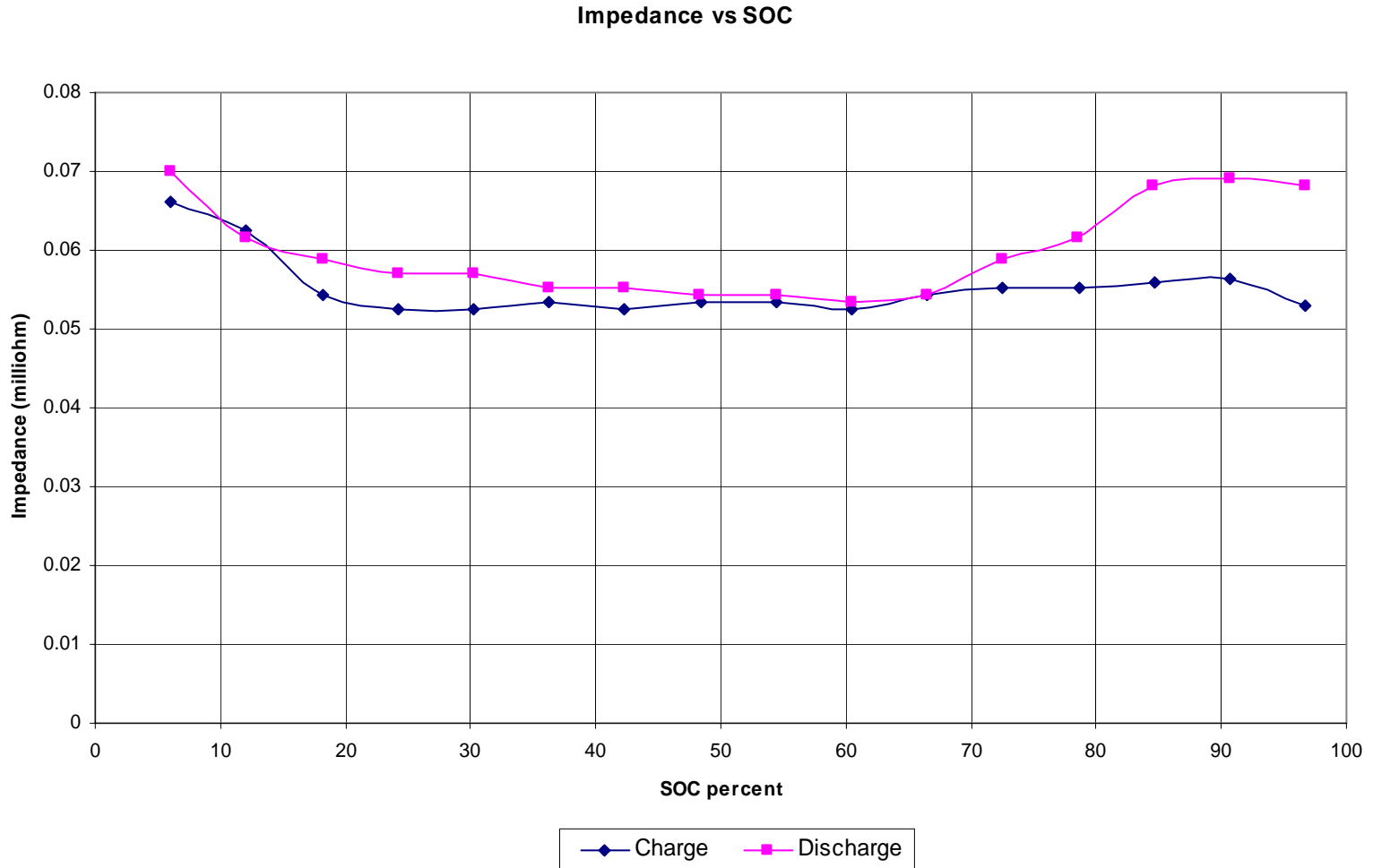

Heat Capacity Measured Using Accelerating Rate Calorimeter (ARC)

Technique:

- Cell insulated and heated under adiabatic conditions in ARC

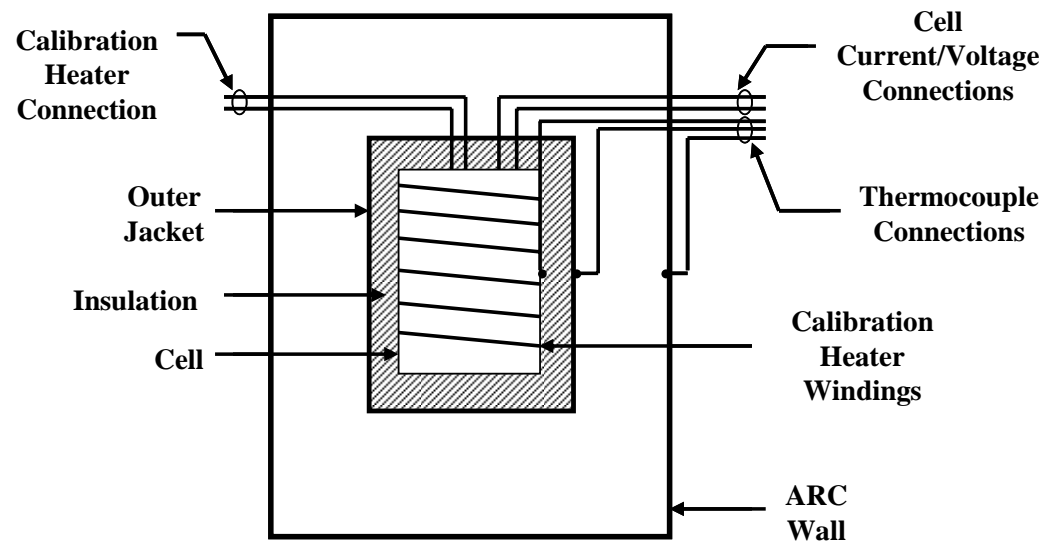



Heat Capacitance Calibration Methods Using the ARC

Aluminum and Copper calibration masses used to calibrate system response and determine addenda heat capacitance

Slope Method:

$$C_p(\text{J/C}) =$$

$$\text{Pwr}(\text{W})/\text{slope}(\text{C/s})$$

Delta T Method:

$$C_p(\text{J/C}) =$$

$$\text{Pwr}(\text{W}) \cdot \text{time}(\text{s})/\text{delta } T(\text{C})$$

EAPU Cal. Run3 Block AI2

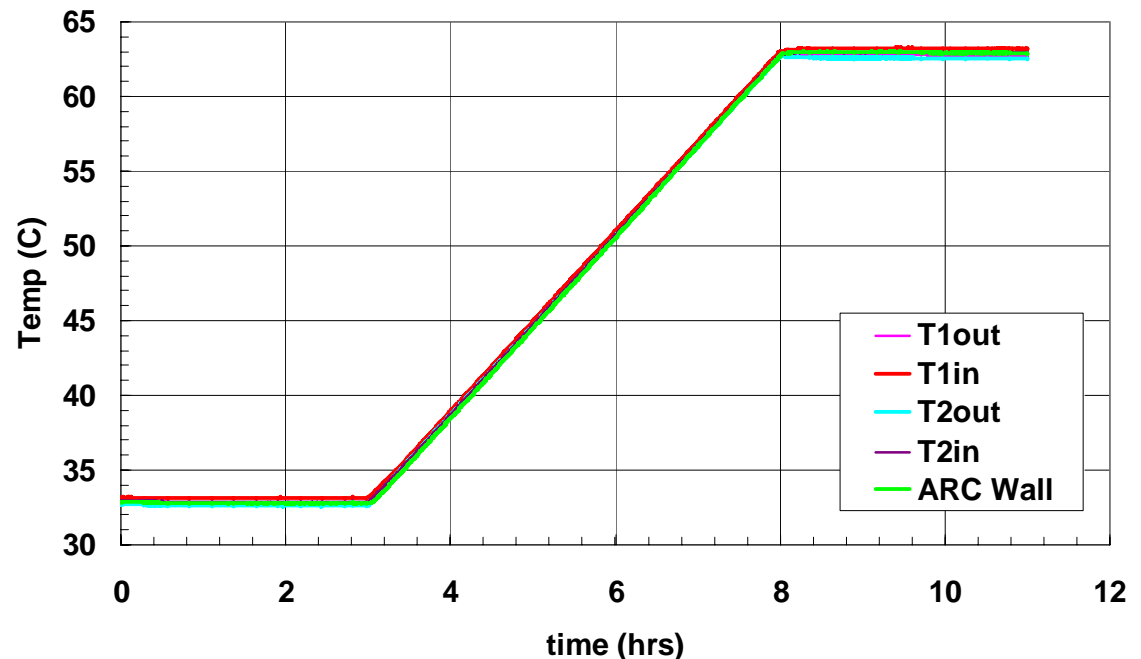



Cell Heat Capacity Summary

Cell Design and #	Specific Heat (J/g-C)
Moli 1	0.806
Moli 2	0.826
Moli 3	0.837
Avg.	0.823
Std.Dev.	0.016
% Std. Dev.	1.9%
Electrovaya single cell	1.166
Electrovaya two cell stack	1.186
Average	1.176
Std. Dev	0.0141
% Std. Dev	1.20%

•Lower mass of cell inerts (no can, crimp, etc) relative to active materials in Electrovaya LIB cell design is possible reason for its higher Cp vs 18650 cell design



Risk Mitigation Plan with Li-ion polymer

- Meeting 5-year service life and 5-year storage life reqts
 - Data on cells > 4 years old is spotty on for pouch cell designs
 - Chemistry is not the issue because >5 year service life has been demonstrated in crimped seal 18650 cells and hermetically sealed aerospace cells
 - The key will be limiting the diffusion of electrolyte from the cells and external moisture into the cells
 - ElectroVaya's double bagging approach with sacrificial electrolyte/desiccant between inner and outer bags
 - Reduce concentration gradient driving force for water diffusing **into** the cell and for electrolyte diffusing **out** the cell
 - Accelerated life tests at SRI (Arab, AL) are planned to quantify the benefit of the double bag and of the sacrificial electrolyte
 - Another key is improving the dryness and cleanliness of their processes
 - Effective and thorough acceptance and lot certification is very important



Self-Discharge as Determined by Microcalorimetry

- Cell heat output measured under OCV
 - Three voltages: 3.8V, 4.0V, 4.2V
 - Five Temperatures: 25°C, 35°C, 45°C, 65°C, 80°C
- Heat output decays as power law function after insertion in microcal
 - Heat output after 24 hrs used to determine activation energy
- Moli cells were measured by SNL (Peter Roth)
- Electrolyte cells were measured in ESTA's new isothermal battery microcalorimeter (Monique Wilburn)

Self Discharge Heat Output Follows Power Law Decay Function

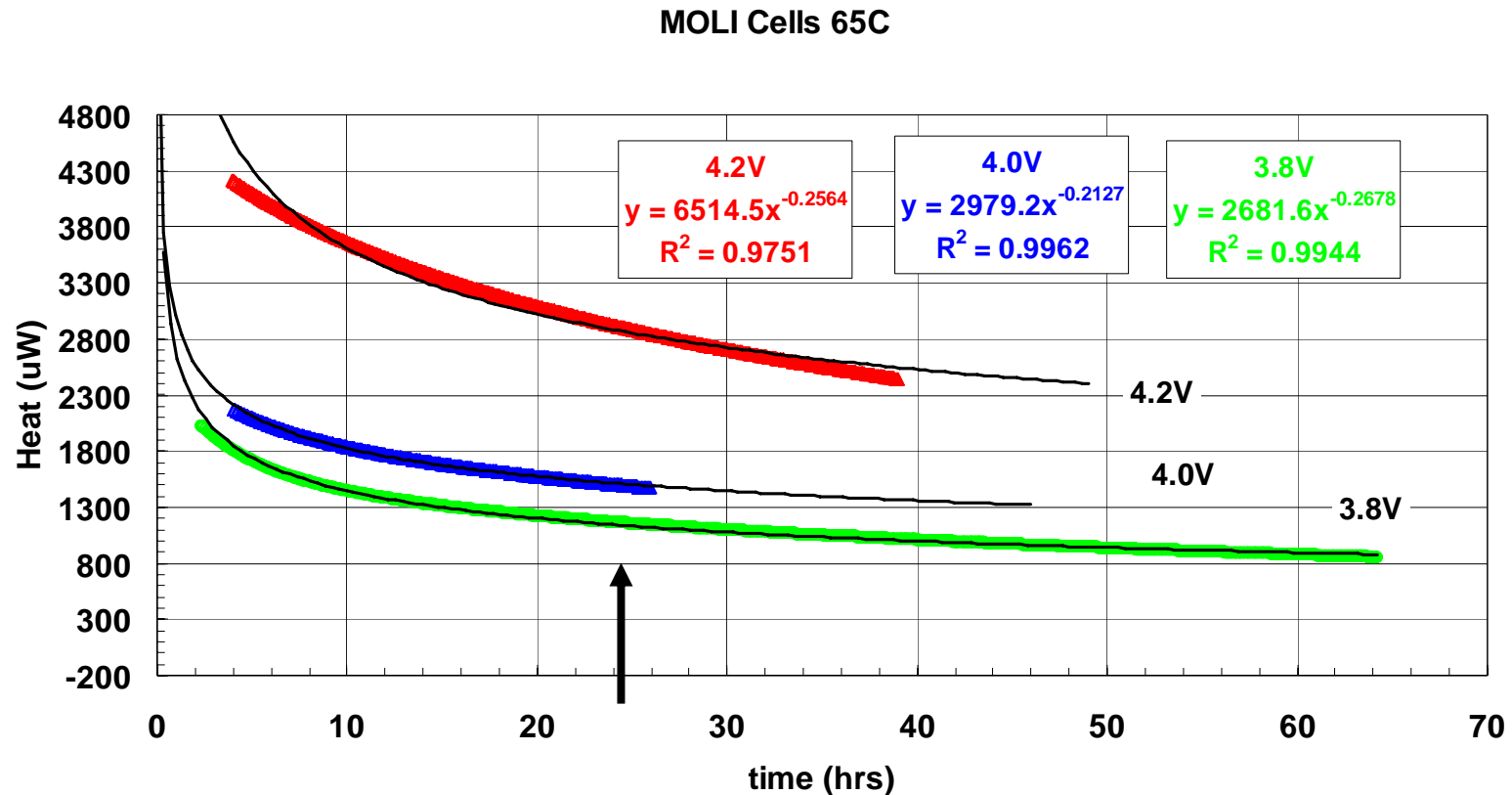

Comparison of OCV heat generation of Electrovaya LIB cells manufactured in 2004 measured at the "as received" SoC

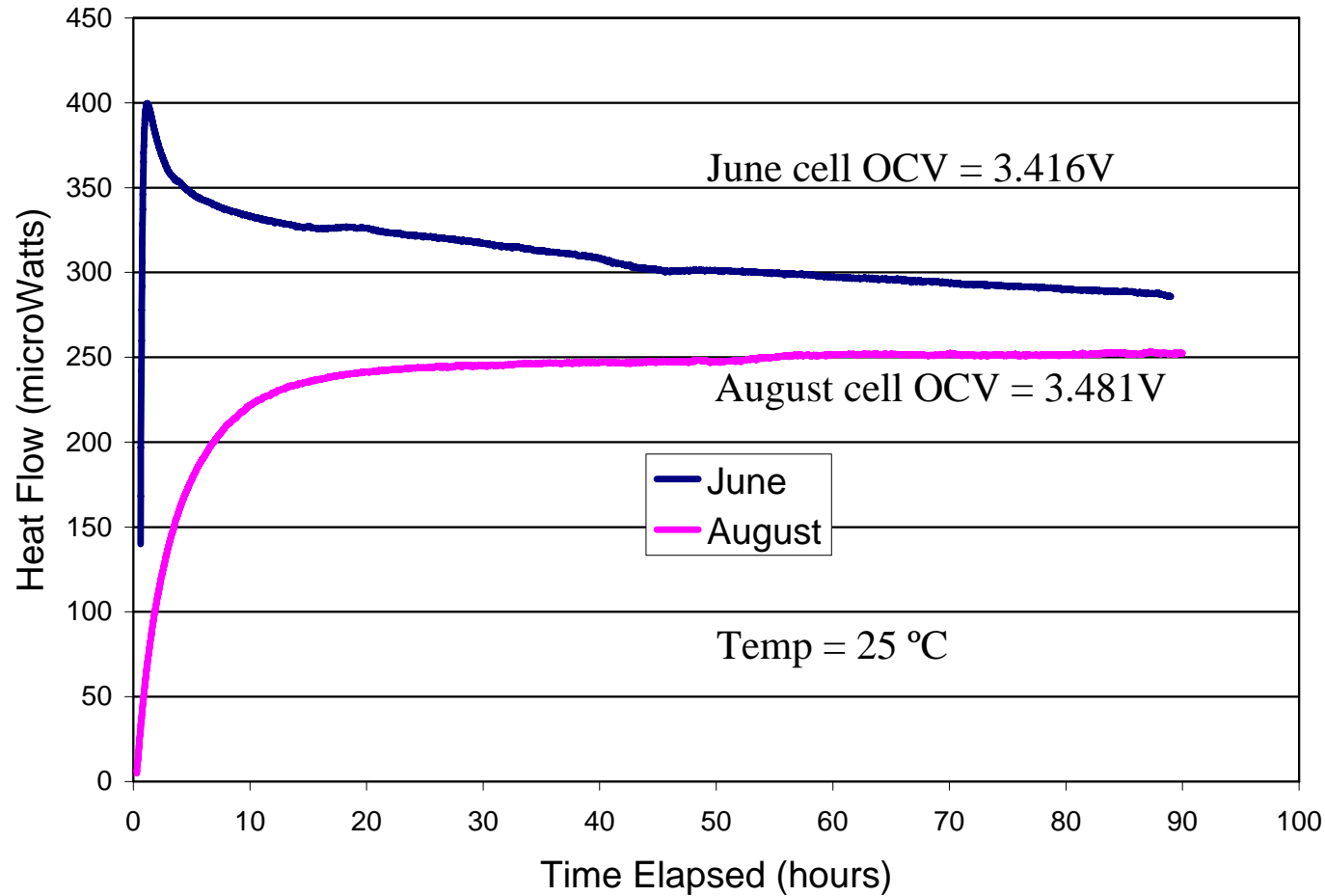

Aerospace Cell Fab Processes Are Cleaner and Drier

Comparison of OCV Heat Generation
Between Electrolyte 8 Ah Li-ion Cells

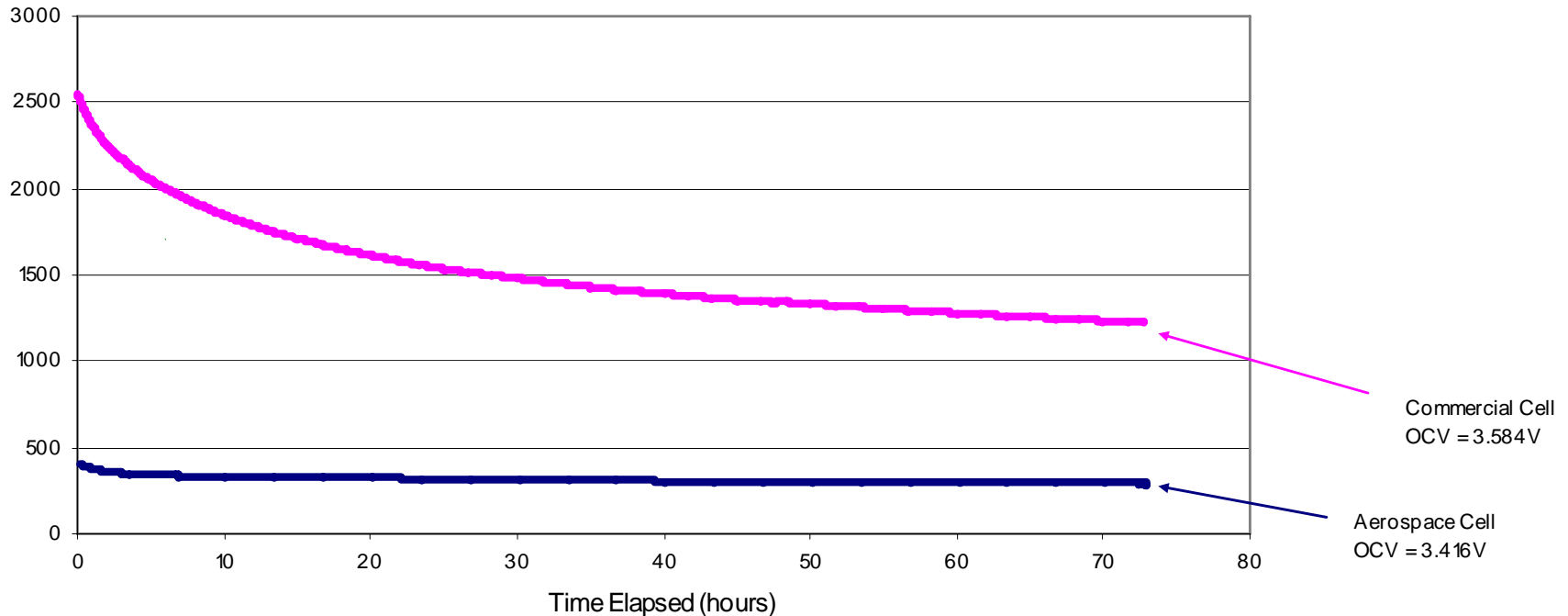

Absence of moisture in “Aerospace” processes believed to reduce parasitic heating



Cell Module Cycling in Vacuum

3.8A Charge to 4.10V with 1.0A taper cut-off
3.8A Discharge to 26.6Ah has achieved >175 cycles

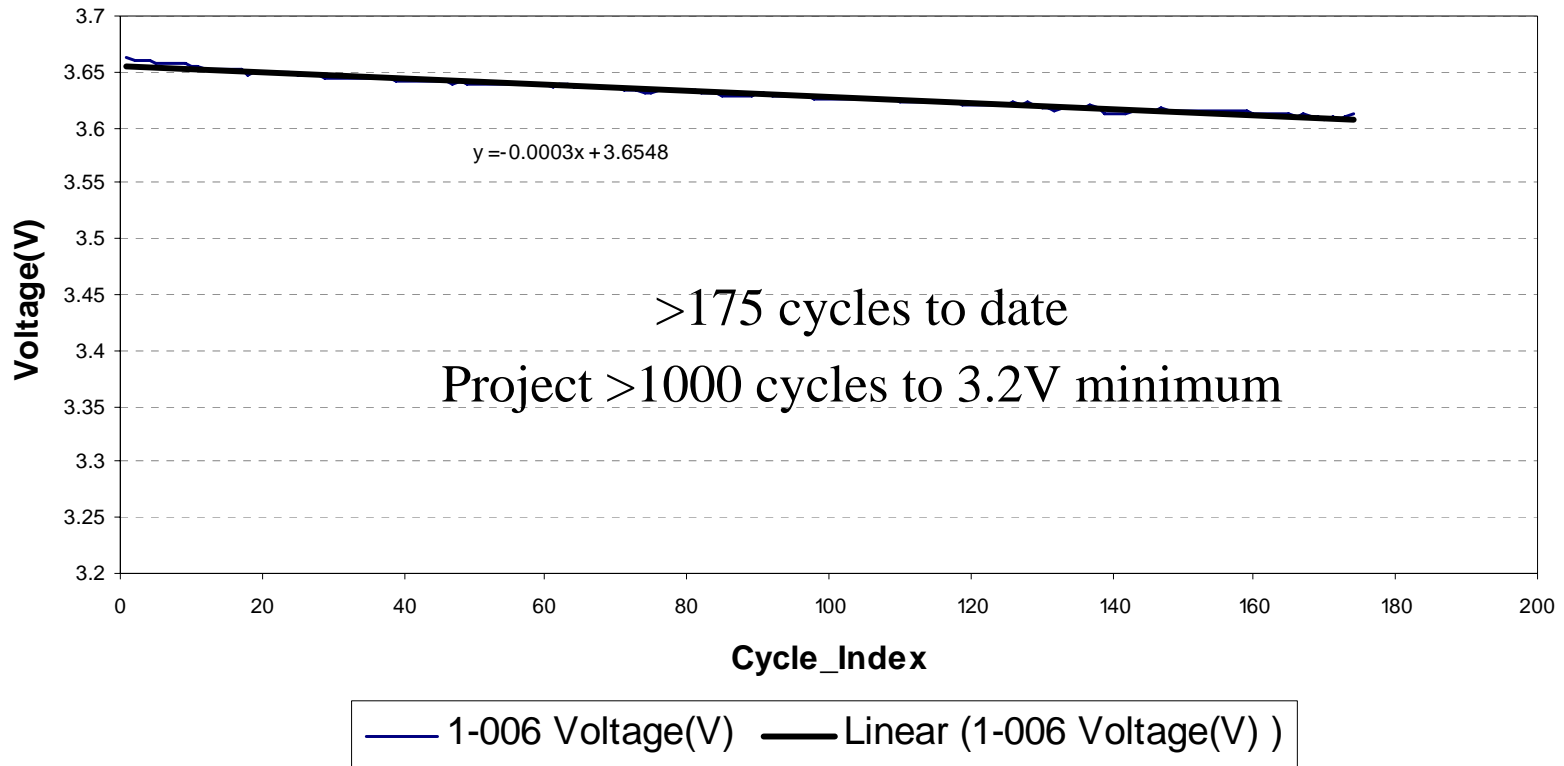

Single cell capacity cycling at ambient T, P

0.76A charge to 4.1V taper 0.2V

0.76A discharge to 5.4Ah cut-off or 3.2V (every 10th cycle)

Discharge_Capacity(Ah), vs. Cycle_Index
Full cycle after 10 nominal cycles

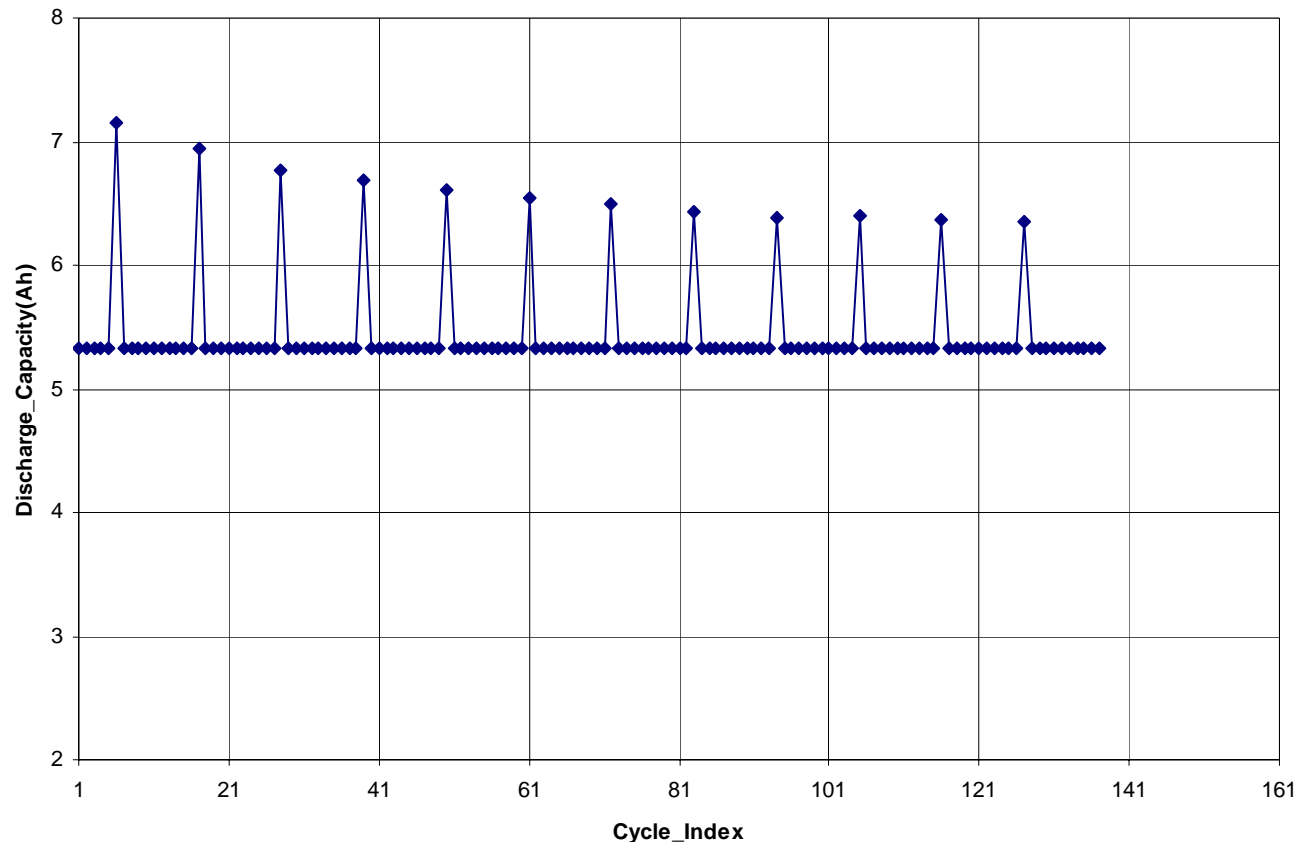

Cell Cycling in Vacuum, Room Temperature

0.76A Charge to 3.96V, taper to 0.5A

0.76A Discharge to 3.57V to extract 27/5=5.4Ah initially

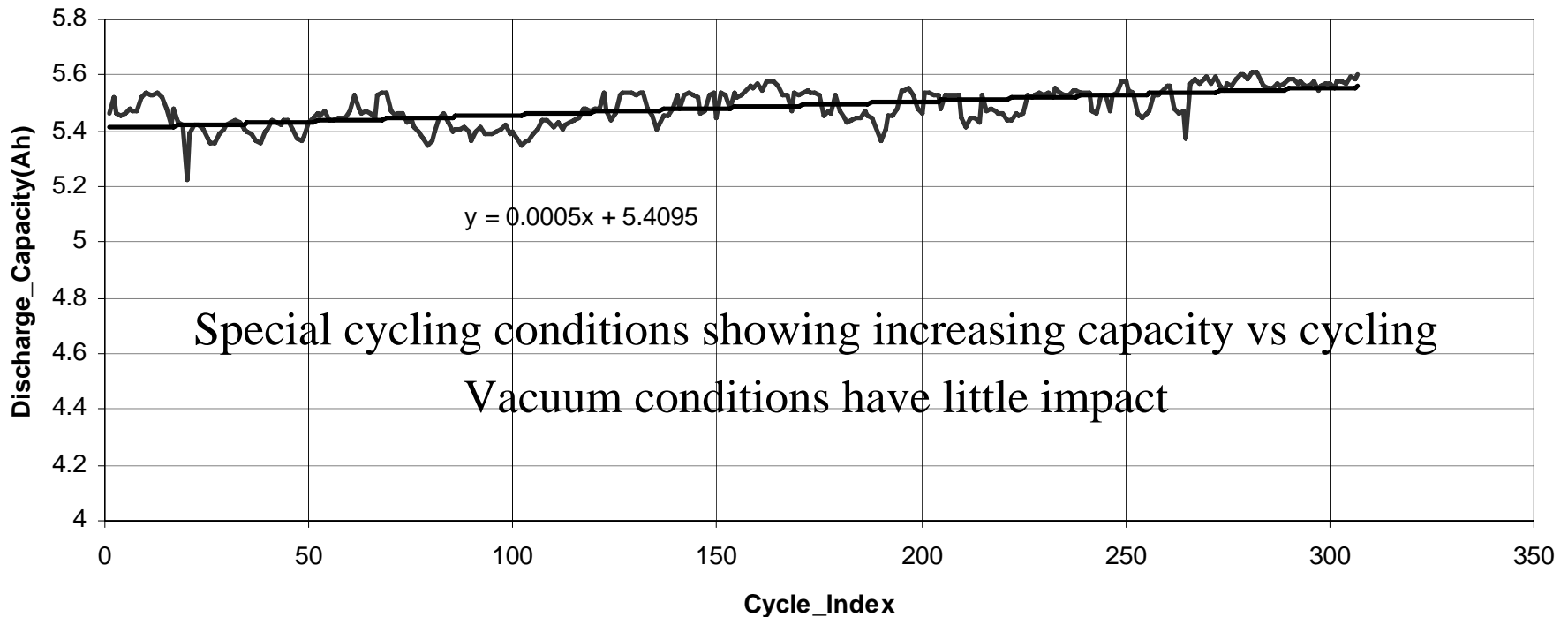

Cell Pouch Leak Pressure Test

Burst Pressure Runs for ElectroVaya 8Ah Cell
Water Burst Was verified with a Load Cell and Visual Check

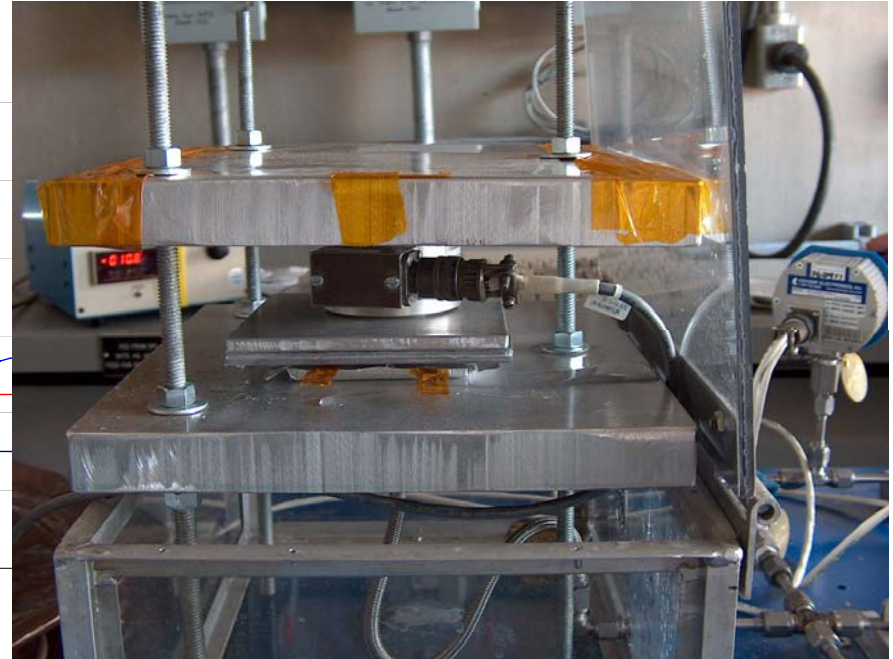
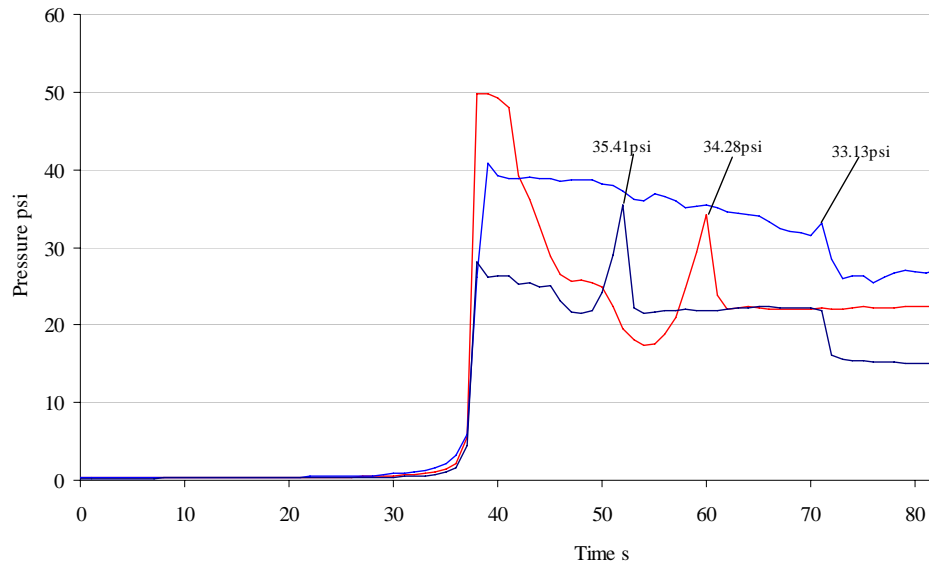

- Large annular fitting was epoxied to flat wall of cell pouch
- Flat sides of cell were supported
- 3 cells tested with hydraulic pressure, leaked within 33 to 36 psia
- In all cases, the tab seal was the weak point



Project Top Level Requirements (cont.)

- LIB Charger Requirements
 - Performance
 - Recharge 2 fully discharged batteries simultaneously
 - in < 8 hours using 120 Vdc input
 - in < 24 hours using 28 Vdc input
 - Discharge 2 fully charged batteries to 16V in <32 hours w/o exceeding 45°C
 - Input power using existing cables
 - 28 ± 4 Vdc from a Shuttle power outlet limited to 10A
 - 120 ± 6 Vdc on ISS power outlet limited to 6A
 - Mass – 8.00 kg (17.6 lbs) without pouch
 - Volume – 15cm x 31cm x 31cm
 - Environmental Performance
 - IVA use only
 - Functional after vacuum exposure while not operating
 - User Interface
 - 5 position rotary switch (charge, off, discharge, volt check, autocycle)
 - LED and LCD indications (for V, I, and Ah counter)
 - USB output for data collection with laptop



Electrical Design of LIB Charger – Main Features

- Power control
 - Control the charge and discharge power levels
- Power conditioning
 - Condition the input power for use by the controllers
- Microcontrollers
 - Main controller monitors cell module voltages & responds to front panel commands
 - Display controller monitors the information on the display
 - Supervisory controller monitors cell module voltages and termination conditions
 - All 3 must work properly to give “Go for EVA” indication
- Equalization (cell balance)
- Display (LCD and LEDs)
- USB support

LIB Charge and Discharge Path

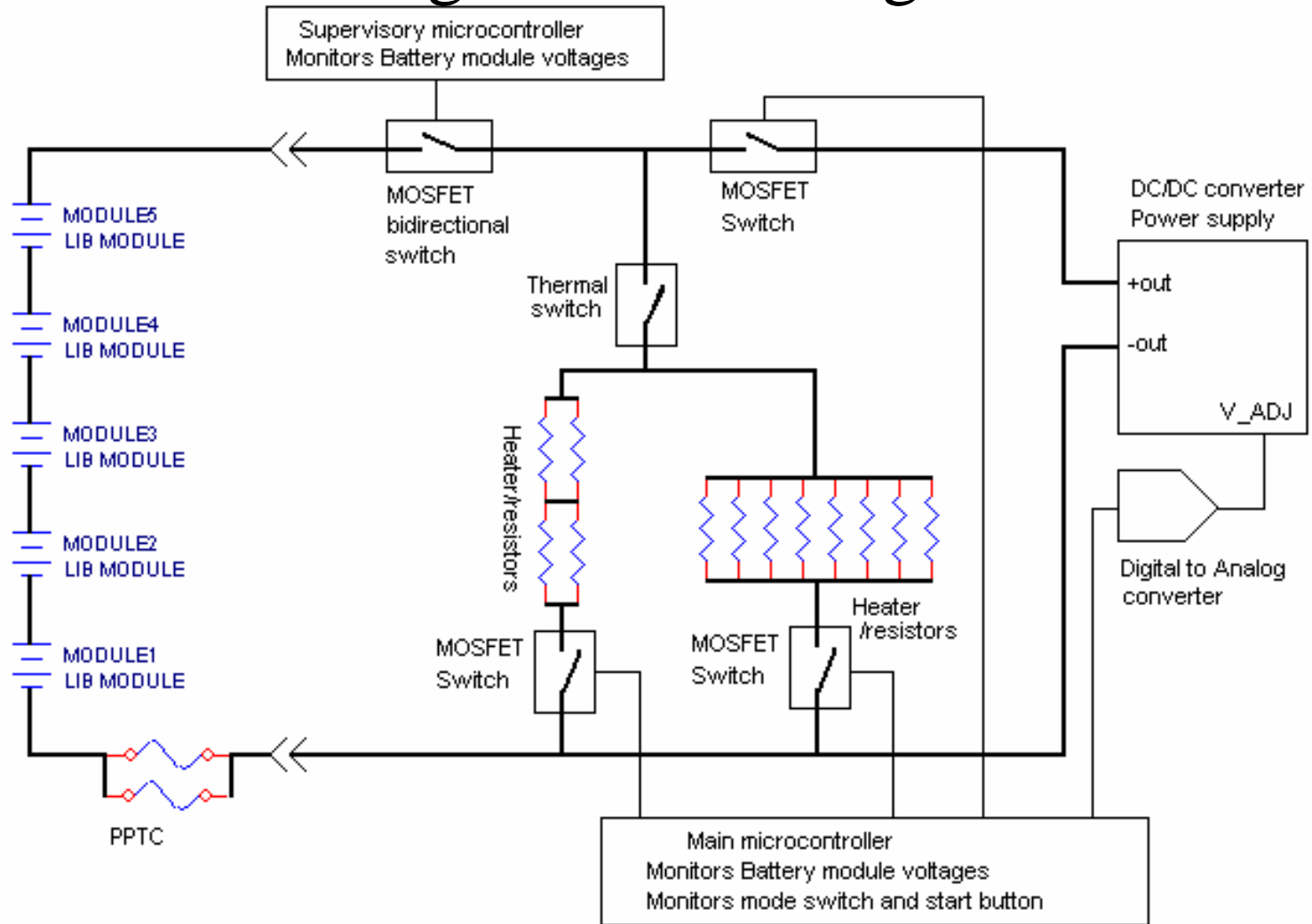

Cell Module Balancing Strategy

Charger performs balancing

- Cell modules charged in series to 20.50V (4.1V/cell)
- During taper charge, higher voltage cell modules are bled down resistively to allow lower voltage modules to catch
- At end of charge, cell modules with high OCVs are bled down resistively to match the low OCV cells

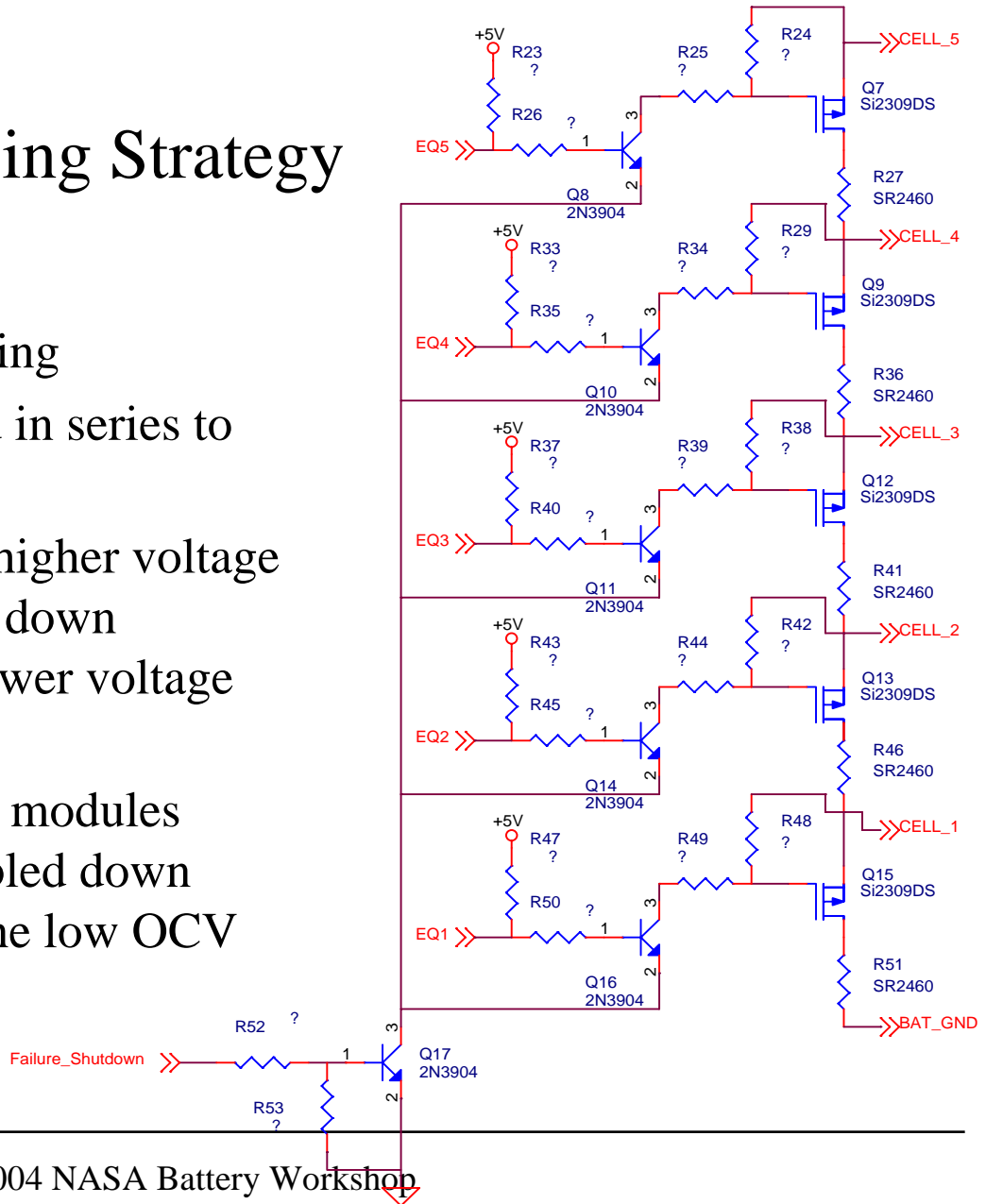



LIB Charger Mechanical Interface

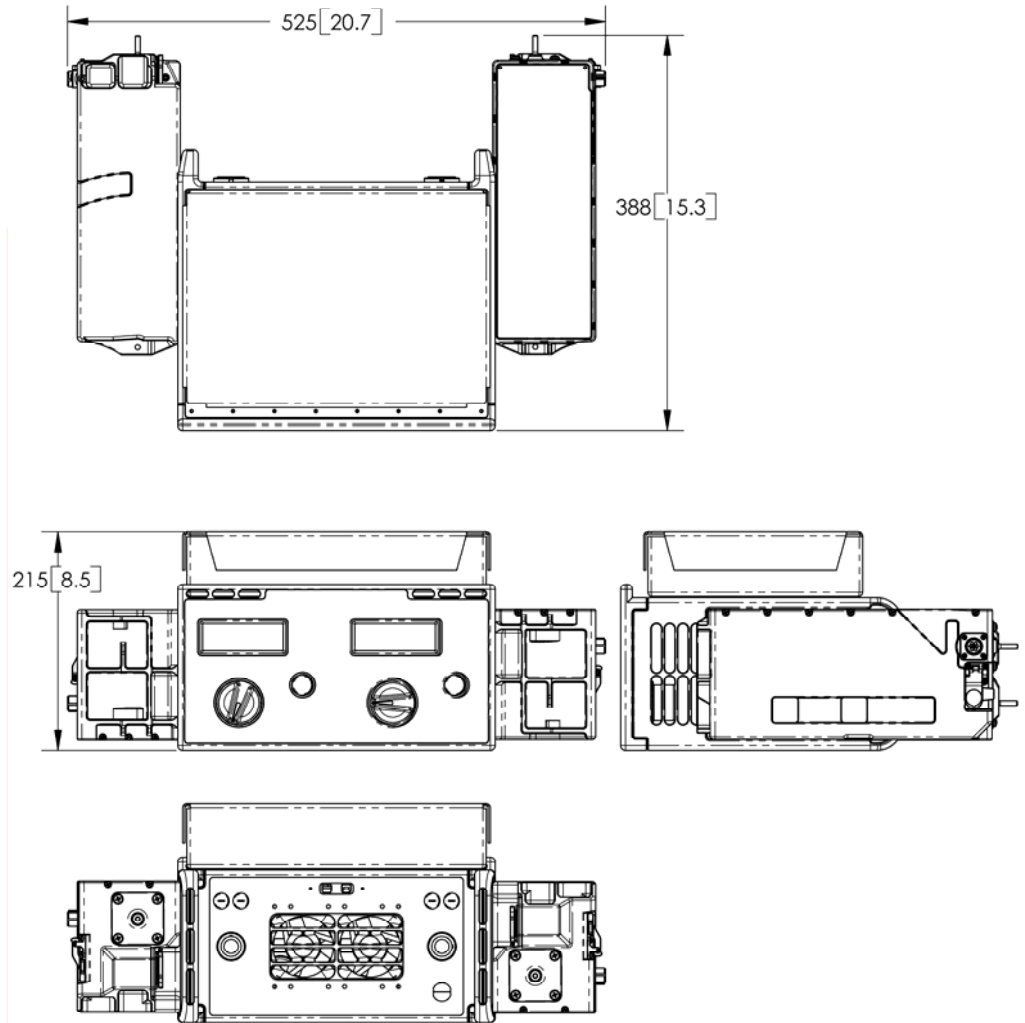
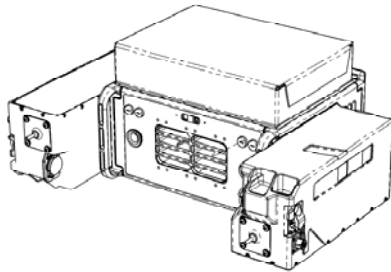
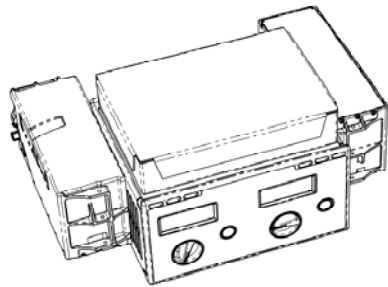

Human Factors – Front & Rear Panels





Safety Strategy for achieving 2-fault tolerance

- Low Impedance Failures
 - External Short Circuit Controls
 - LIB fast blow fuse in negative leg rated at 15A
 - Simple LIB electrical design without active electronics that can fail short
 - Cell module to show tolerance to hard and smart (max power) short
 - Internal Cell Short Circuit Controls
 - Dual separator
 - Cleaner manufacturing processes
 - 1 week hold cell test to screen out soft shorts
 - Vibration screening at cell module and battery level
 - Solid aluminum LIB housing and kevlar lined garment to protect against micro-meteorites
 - Loss of power to Spacesuit requires activation of secondary oxygen supply in backpack giving crewman 30 minutes to return to airlock

Safety Strategy for achieving 2-fault tolerance (cont.)

- Low Impedance Failures
 - External Short Circuit Verifications
 - Cell 20 mohm short – 42A peak, max cell temp = 70C, neg Ni tab seal melts and vents with smoke
 - Cell 60 mohm short - 30A peak, max cell temp = 52C, neg Ni tab seal melts and vents with smoke
 - Cell module 20 mohm short – 113A peak, cell venting does not breach outer bag, no odor
 - Cell module 60 mohm short – 50A peak, no visual damage, still rechargeable
 - LIB protected by 15A fast blow fuse
 - Internal Short Circuit Hazard
 - Violent venting and fire result from wiggling penetrated lexan nail, not from the initial penetration











Safety Strategy (cont.)

- High Impedance Failures
 - Battery or Cell Module Open Circuit Controls
 - Simple LIB design with no active circuitry that can fail open
 - Redundant contacts on spacesuit connector
 - Redundant terminal screws on each cell module
 - Open Cell Hazard Controls
 - Demonstrate tolerance to charging with 21.8V charger with 100% cell imbalance
 - Demonstrate LIB charger will detect open cells, stop charging, and show fault
 - Leaky Cell Hazard Controls and Verifications
 - No free electrolyte in the cells
 - Acceptance leak test of cell pouch
 - Cell module (5P) is sealed in an outer pouch
 - Showed tolerance to overcharging with 21.8V Charger at cell module level
 - Demonstrated that volatile released from leaky inner and outer bags while stored in vented aluminum battery housing will not exceed the maximum spacecraft allowables
 - Cell Balancing Hazard Control
 - LIB Charger perform cell balancing every time it charges the LIBs
 - Crew required to use it at least once a year
 - Loss of power to Spacesuit requires activation of secondary oxygen supply in backpack giving crewman 30 minutes to return to airlock

Issues still in work

Cell level

- Stability of vendor's new aerospace cell production line still not demonstrated after 9 months and >1000 cells
 - Occurrence of soft shorts, loss of vacuum seal, and impedance growth is too high (24 failures out of > 700 cells fabricated), but failure trend among new cell batches is improving
 - Isothermal microcalorimetry on new lots of cells indicates lower self discharge heating compared to older lots
- Solution – Improve processes, make more lots, and strict screening

Cell module level

- Al tab crimped into nickel plated copper terminal block failures
 - High resistance has developed in 1 crimp out of 5 in 13 cell modules out of 70 made causing a sudden 20% capacity degradation.
 - Suspected root cause – Corrosion of Cu/Al interface due to insufficient Ni plating of the terminal
 - Bypassing the crimp terminal with spot welded cross bar on cell tabs enables full capacity recovery
- Solution – Replace crimps with Ni tab welded to Ni terminal
 - Al tab from cell will be spliced with a resistive spot welded Ni tab covered with polymer seal
 - Eliminates crimps with dissimilar interface

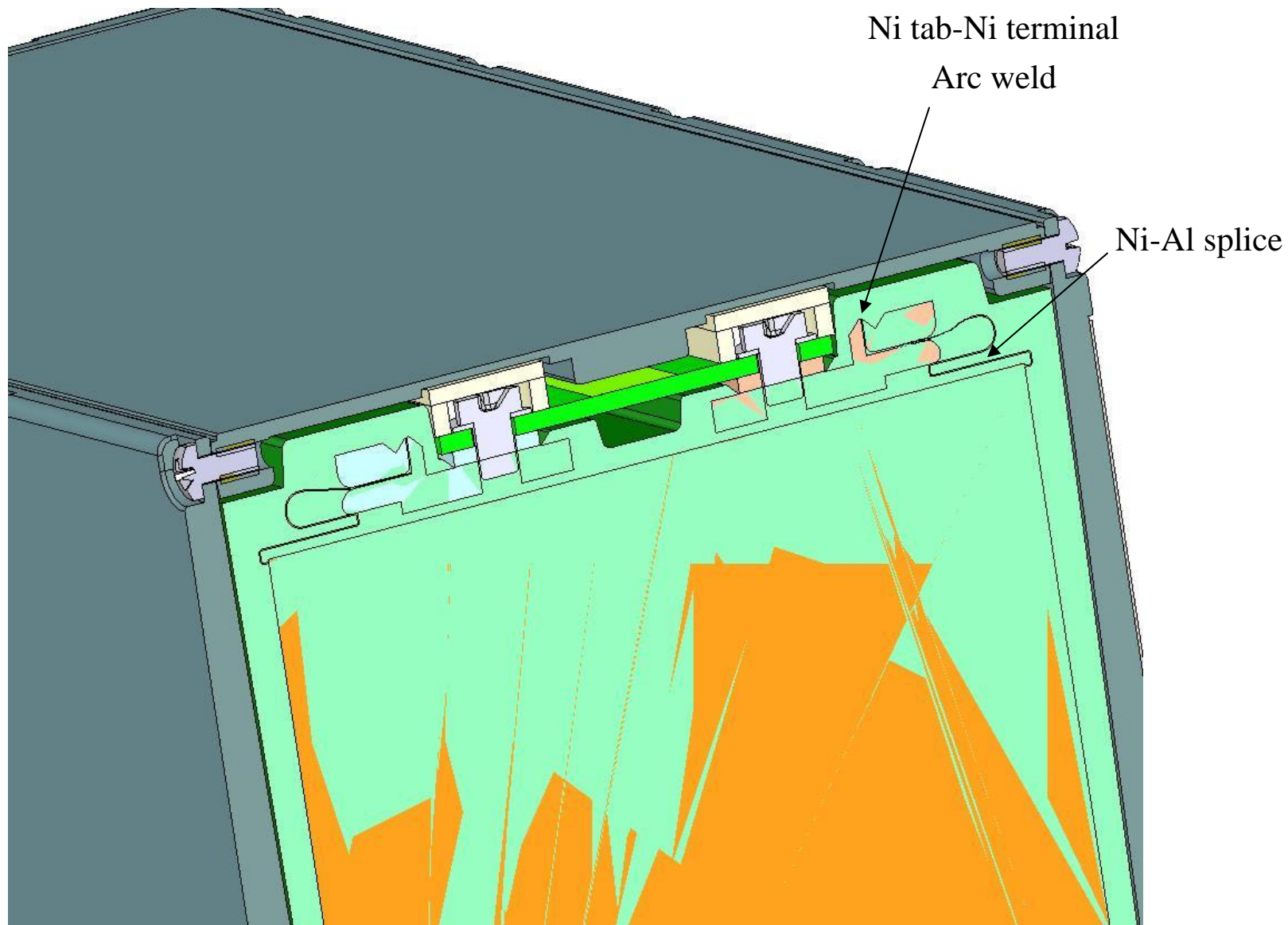



Summary & Schedule

- Electrovaya's aerospace cell production line is improving, but must further improve to achieve acceptable reliability
- Completed functional, vibration, and thermal cycling of LIB
- So far, electrical safety tests have produced good results
- Completed functional, vibration, thermal cycling, power quality and EMI of LIB Charger
- Completed CDR on 9/23/04
- Manufacturing Readiness Review for flight cell/battery production scheduled for Dec 04