

NASA/CR-2008-215122



# Evaluation of Advanced Composite Structures Technologies for Application to NASA's Vision for Space Exploration

*Darrel R. Tenney*  
*Analytical Services & Materials, Inc., Hampton, Virginia*

---

July 2008

## The NASA STI Program Office . . . in Profile

Since its founding, NASA has been dedicated to the advancement of aeronautics and space science. The NASA Scientific and Technical Information (STI) Program Office plays a key part in helping NASA maintain this important role.

The NASA STI Program Office is operated by Langley Research Center, the lead center for NASA's scientific and technical information. The NASA STI Program Office provides access to the NASA STI Database, the largest collection of aeronautical and space science STI in the world. The Program Office is also NASA's institutional mechanism for disseminating the results of its research and development activities. These results are published by NASA in the NASA STI Report Series, which includes the following report types:

- **TECHNICAL PUBLICATION.** Reports of completed research or a major significant phase of research that present the results of NASA programs and include extensive data or theoretical analysis. Includes compilations of significant scientific and technical data and information deemed to be of continuing reference value. NASA counterpart of peer-reviewed formal professional papers, but having less stringent limitations on manuscript length and extent of graphic presentations.
- **TECHNICAL MEMORANDUM.** Scientific and technical findings that are preliminary or of specialized interest, e.g., quick release reports, working papers, and bibliographies that contain minimal annotation. Does not contain extensive analysis.
- **CONTRACTOR REPORT.** Scientific and technical findings by NASA-sponsored contractors and grantees.

- **CONFERENCE PUBLICATION.** Collected papers from scientific and technical conferences, symposia, seminars, or other meetings sponsored or co-sponsored by NASA.
- **SPECIAL PUBLICATION.** Scientific, technical, or historical information from NASA programs, projects, and missions, often concerned with subjects having substantial public interest.
- **TECHNICAL TRANSLATION.** English-language translations of foreign scientific and technical material pertinent to NASA's mission.

Specialized services that complement the STI Program Office's diverse offerings include creating custom thesauri, building customized databases, organizing and publishing research results ... even providing videos.

For more information about the NASA STI Program Office, see the following:

- Access the NASA STI Program Home Page at <http://www.sti.nasa.gov>
- E-mail your question via the Internet to [help@sti.nasa.gov](mailto:help@sti.nasa.gov)
- Fax your question to the NASA STI Help Desk at (301) 621-0134
- Phone the NASA STI Help Desk at (301) 621-0390
- Write to:  
NASA STI Help Desk  
NASA Center for AeroSpace Information  
7115 Standard Drive  
Hanover, MD 21076-1320

NASA/CR-2008-215122



# Evaluation of Advanced Composite Structures Technologies for Application to NASA's Vision for Space Exploration

*Darrel R. Tenney*  
*Analytical Services & Materials, Inc., Hampton, Virginia*

National Aeronautics and  
Space Administration

Langley Research Center  
Hampton, Virginia 23681-2199

Prepared for Langley Research Center  
under Contract NNL04AA10B

July 2008

The use of trademarks or names of manufacturers in this report is for accurate reporting and does not constitute an official endorsement, either expressed or implied, of such products or manufacturers by the National Aeronautics and Space Administration.

Available from:

NASA Center for AeroSpace Information (CASI)  
7115 Standard Drive  
Hanover, MD 21076-1320  
(301) 621-0390

National Technical Information Service (NTIS)  
5285 Port Royal Road  
Springfield, VA 22161-2171  
(703) 605-6000

## Table of Contents

<b>A. Executive Summary</b> .....	<b>1</b>
<b>B. Introduction</b> .....	<b>4</b>
<b>C. Weight Reduction Calculations for Composite Structures in Constellation Program</b> .....	<b>8</b>
C.1 Ares I and Ares V Cryogenic Propellant Tanks.....	8
C.2 Ares I Interstage Cylindrical Shell .....	14
C.3 Lunar Surface Access Module (LSAM) Ascent Module Liquid Methane Tank .....	18
C.4 Lunar Surface Manipulator .....	20
<b>D. Technology Assessment Process and Results</b> .....	<b>25</b>
D.1 Spreadsheet Rating Process .....	25
D.2 Top Rated Technologies .....	26
<b>E. Issues-Needs-Payoff &amp; Recommended Future Research For Highest Priority Technologies</b> .....	<b>27</b>
E.1 Low Permeability Microcrack Resistant Resins/Composites.....	28
E.2 Non-autoclave Cure Composites for Large Tanks.....	35
E.3 NDE Inspection of Composites .....	52
E.4 Structural Health Monitoring (SHM) .....	58
E.5 Adhesive Bonding Technology for Extreme Temp. Environments .....	64
E.6 Lunar Surface Systems .....	68
E.7 High Fidelity Structural Analyses .....	72
E.8 Rapid Conceptual Design Methodology (RCDM).....	79
E.9 Smart Space Composites Design Guide .....	82
<b>F. Concluding Remarks</b> .....	<b>94</b>
<b>G. Appendices</b> .....	<b>96</b>
A.1 Structural Elements and Leading Concepts for Composite Applications to the Constellation Program	
A.2 Composite Technologies Evaluated and Technology Assessment Process	
A.3 Example Technology Assessment Spreadsheets for Ares I Upper Stage Cryotank	
A.4 Lightweight Composite Propellant Tanks for Lunar Surface Access Module (LSAM) Storyboard	

## **A. Executive Summary**

Analytical Services & Materials, Inc. (AS&M) is pleased to submit this final report in response to the task order entitled "Evaluation of Advanced Composite Structures Technologies for Application to NASA's Vision for Space Exploration" issued under Contract NNL04AA10B, Structures & Materials, Aerodynamic, Aerothermodynamics, & Acoustics Technology for Aerospace Vehicles (SMAAATAV). This document contains our overall technology assessment approach, results of weight reduction calculations for six different composite structural elements, identification of the highest potential payoff technologies, identification of barrier issues, and R&D recommendations for eliminating these barriers.

### **Composite Constellation Applications**

AS&M performed a broad assessment survey and study to establish the potential composite materials and structures applications and benefits to the Constellation Program Elements, including the Ares I Launch Vehicle, the Ares V Launch Vehicle, the Earth Departure Stage, the Orion Crew Exploration Vehicle (CEV), the Lunar Surface Access Module (LSAM), and Lunar Surface Systems. The infrastructure at the lunar surface includes: rovers, habitats, payload handling devices, resource utilization equipment, and other relevant infrastructure that may benefit from composites technology. Although these surface infrastructure elements are relatively small (as compared to the launch vehicles for example), there is a premium on mass landed at the lunar surface and these elements can benefit significantly from lightweight design technologies. Requirements for these structural elements were established by examining the prime design drivers including loads and environments, packaging requirements, and other critical systems requirements. Trade studies were performed on selected elements to determine the potential weight or performance payoff from use of composites. Weight predictions were made for: (1) Ares I Upper Stage (US) liquid hydrogen and liquid oxygen tanks, Ares V Earth Departure Stage (EDS) and Core Stage (CS) liquid hydrogen tanks, (2) Ares I Interstage Cylindrical Shell, (3) Lunar Surface Access Module (LSAM), Ascent Module liquid methane tank, and (4) Lunar Surface Manipulator. For the Ares I and Ares V cryotanks, weights were calculated for IM7/977-2 honeycomb sandwich composite tanks concepts and compared to aluminum lithium isogrid cryogenic propellant tanks. These comparisons indicated that a weight savings in excess of 30 percent could be achieved with composite tanks. Predicted weight savings on the same order are expected for Ares I and V liquid oxygen tanks.

### **Composite Weight Savings**

The weight savings calculated for the composite tanks were for lineless tanks. By employing toughened resins and composite formulations optimized for cryogenic applications permeability can be maintained at an acceptable levels to avoid the extra weight of metal liners. However, additional work related to the optimization of these toughened composites for microcrack resistance and low hydrogen permeability are included in this report. Ares I tanks which are less than 30 ft. in diameter can be fabricated in existing autoclaves. However, no autoclaves large enough to accommodate the 33 ft. diameter Ares V tanks exist. Therefore, non autoclave cure processes that can yield "autoclave quality" consolidated composite structures must be developed or a new larger diameter and length autoclave is required for the Ares V tanks. To avoid the high cost to build, maintain, and operate a super size autoclave NASA should sponsor R&D on non-autoclave processing for large tank structures. One of the most promising non-autoclave processes

involves thermoplastic in-situ consolidation with a heated placement head. In this approach, a high normal force is employed by the heated head during placement to achieve the required low porosity microstructure. As with most of the automated non-autoclave techniques, innovative conformable compactors are required for placing on complex shapes. Such compactors have been successfully proven out and are described in this report. A detailed approach for fabricating thermoplastic composites out of the autoclave is outlined in this report.

### **Lunar Surface Systems**

Another important finding from the weight saving calculations was that for the Lunar Surface Systems composite look particularly attractive for cranes and manipulator arms to move hardware on the Lunar Surface. Masses calculated for a simple manipulator arm cantilevered from the root were approximately 15% lighter for composites versus aluminum. However, the manipulator mass was dramatically reduced by changing structural concepts. Switching to a cable stiffened structure reduces the manipulator mass nearly an order of magnitude. This is primarily because of the highly improved mechanical advantage that offset cables provide. Introducing a truss as the structure for the arm provides an additional factor of two mass savings. For both of these concepts, the composite mass savings is about 30%. To achieve high efficiency for the manipulator, advances are needed in rods, cables, joints, and deployable trusses. These same structural elements will provide weight savings for a number of different Lunar surface structures such as solar shelters, regolith support structures for radiation shielding, antennas, bridges, etc. In this study a deployable beam merit performance chart was developed to provide a rational means for comparing the efficiency of various beam concepts and can be used to ensure that only the most efficient beam structures are developed. Calculations showed that a 40 msi modulus material beam is twice as efficient as a 20 msi composite beam. It also has the additional advantage of being 30 % smaller in diameter which provides more compact packaging. It is highly recommended that a performance metric chart be developed for each type of surface element to ensure only efficient devices are developed and to guide the technology program.

### **Technology Assessments**

A key part of this study was the evaluation of 88 different composite technologies to establish their criticality to applications for the Constellation Program. The first step in this process was to examine all the major elements of the Constellation Program to identify the principle structural elements and leading structural concepts for composite applications to the Constellation Program. By analyzing these concepts and studying the structural requirements each of the technologies were ranked for: (1) level of technology development required, (2) degree of importance, and (3) degree of difficulty to mature the technology in time to impact the Constellation Program. A detailed description of the process and the rationale behind the various evaluations and rankings is presented in the Appendices along with specific examples of how it was applied to different structural components of the Constellation Program. Based on this assessment the top rated technologies were: (1) Low Permeability Microcrack Resistant Resins/Composites, (2) Non-autoclave Cure Composites for Large Tanks, (3) Non-Destructive Evaluation (NDE) of Composites, (4) Structural Health Monitoring (SHM), (5) Adhesive Bonding Technology for Extreme Temperature Environments, (6) Lunar Surface Systems, (7) High Fidelity Structural Analyses, (8) Rapid Conceptual Design Methodology, and (9) Smart Space Composites Design Guide. Detailed discussions on each of these areas are included in the report along with specific recommendations for advancing key needs and issues. Although technology issues are identified viable solutions are proposed that can logically lead to maturation of the technologies such that

composites can and should be used in many different parts of the Constellation Program. To realize the weight savings potential of composite space structures it is imperative that NASA sponsor an aggressive technology development program aimed at early resolution and maturation of the issues identified in this report.

### **Smart Composites Design Guide**

The widespread use of advanced composites in all elements of the Constellation program will result in critically needed mass savings along with associated reductions in mission costs. To achieve these benefits, however, a long range, balanced composite technology program is needed. To ensure that the information developed from this technology program is well organized, documented, and available to the large teams of engineers that will be required to implement the Constellation program, it is essential to have in place a modern, web-based information retrieval system in which all of the new technology is archived and continually updated. A system for achieving this is referred to as a "Smart Design Guide for Composite Space Structures." In numerous past programs, a significant amount of the technology developed at great expense, was lost due to lack of maintaining adequate records. With current computer and web capabilities, the technology is available not only to archive vast records, but to provide a smart and rapid retrieval system for technologists, designers, mission analysts, and program managers.

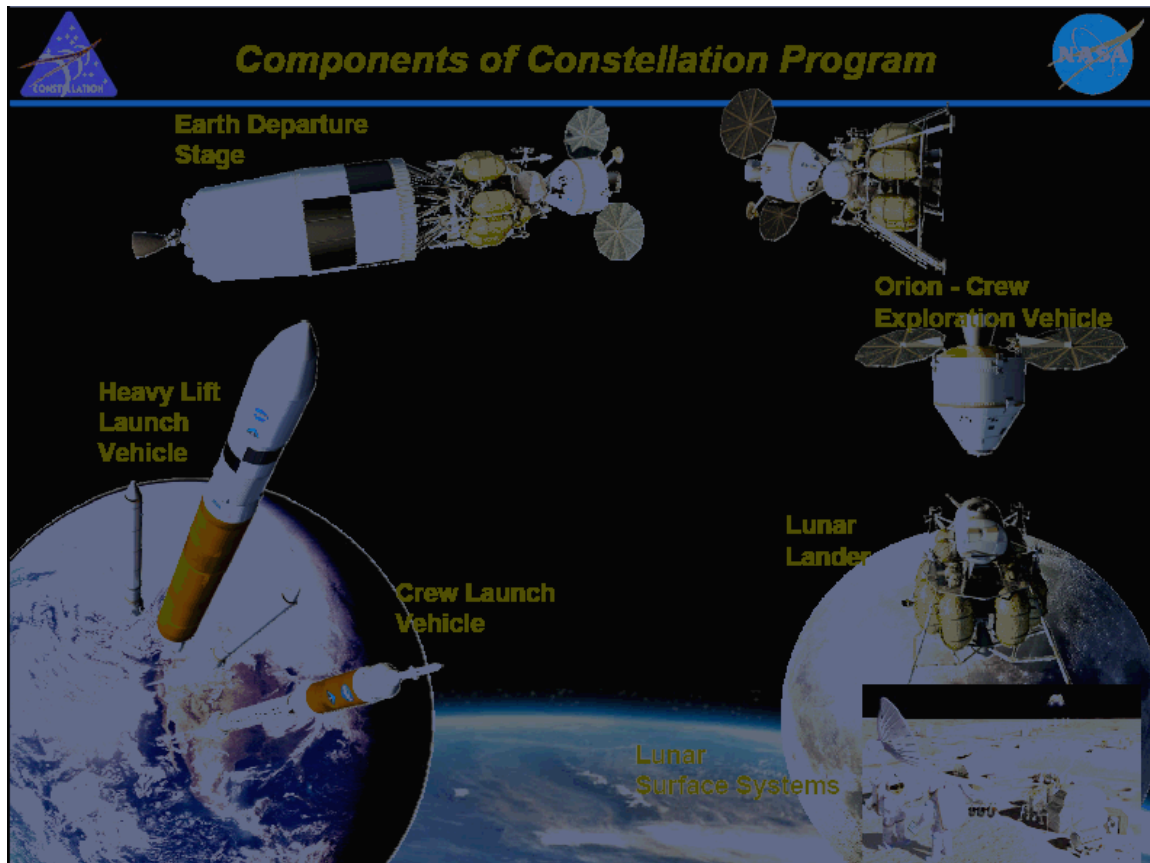
To ensure that the Smart Design Guide is user friendly and of lasting value, its development must be pursued in a systematic fashion. The content and architecture should continually be controlled by a steering panel consisting of users, technologists and sponsors. The use of metric charts will provide a rapid understanding of the state-of-the-art of each technology and will be a valuable aid for design as well as for guiding future technology investments.

### **Technology Investment**

The overall outcome of this study shows that composites are viable structural materials which offer from 20% to 40% weight savings for many of the structural components that make up the Major Elements of the Constellation Program. NASA investment in advancing composite technologies for space structural applications is an investment in America's Space Exploration Program. To ensure that the Constellation Program builds on the success of past program such as the Apollo program advancements in critical enabling technologies must be an integral part of NASA's investment strategy.



## B. Introduction



### Background

One of the primary goals of the Vision for Space Exploration (VSE) is to implement a sustained and affordable human and robotic program to explore the solar system and beyond, starting with a human return to the Moon by the year 2020. The Moon will serve as a testing ground for eventual sustained human and robotic exploration of Mars and other destinations. Lunar exploration will be initiated through a series of robotic missions to the Moon designed to prepare for and support future human exploration activities. The first extended human expeditions to the lunar surface are expected in the 2015 to 2020 timeframe. In addition to preparing for the exploration of other destinations, lunar exploration activities will be used to further science and to develop new test approaches, technologies, and systems. These will include using lunar and other space resources to support sustained exploration. The current focus of NASA's lunar architecture is on the build-up of a permanent outpost, most likely at the lunar South Pole.

Central to the Vision for Space Exploration is the development of new vehicles which will provide crew and cargo transportation for missions beyond low Earth orbit. Currently these are contained in NASA's Constellation Program, which includes the Ares I Crew Launch Vehicle, the Ares-V Heavy Lift Cargo Launch Vehicle, the Orion Crew Exploration Vehicle, and the Lunar Lander. A variety of infrastructure elements will also be required at the lunar surface to support

outpost buildup. These include items such as rovers, habitats, payload handling devices, equipment for in-situ resource utilization, storage structures, scientific instruments and platforms.

Necessary to accomplishing the VSE, is the additional correlating goal of developing innovative technologies that are required to support the vision. The vehicles and payloads for exploration of the Moon and beyond will be mass critical, requiring novel and lightweight structural concepts for successful implementation. Composite materials are ideal for structural applications where high strength-to-weight and stiffness-to-weight ratios are required.

## **Objectives of Work**

The overall objective of this effort was to evaluate composite material technologies and manufacturing methods that represent the leading edge (and slightly beyond) of the current state of the art. High payoff technologies that could have a significant impact on the mass, cost, or reliability of the various VSE architecture components were identified. Emphasis was placed on identifying and evaluating high potential impact technologies, but with conquerable hurdles that currently discourage or prevent implementation of the technology. Additionally, it must be possible to overcome these “hurdles” at reasonable cost and within a timeframe that allows for insertion of the technology into NASA programs. The ultimate goal is to direct future investments in those technologies that will enable the broadest possible use of advanced composites technologies across NASA's exploration mission programs, with demonstrable improvements in weight, cost, or risk. The intent of this study was to leverage the broad experience of industry in evaluating composite structures technologies for future investment. Task Orders were awarded to Northrop Grumman, Boeing, and AS&M. Coordination meetings between the three contractors and an in-house NASA team of discipline experts took place at the kick-off meeting, at the mid-term review and at the final review held at Langley on Jan. 23, 2008.

## **Technical Approach**

An extensive literature and web based search of technologies of interest for different elements of the Constellation program was performed. These technologies were evaluated for their potential impact on NASA's exploration missions, the current level of technology readiness, the barriers to implementation, the degree of difficulty required to mature the technology. A process for ranking the technologies was developed and agreed upon between NASA and AS&M prior to the mid-term review. The results of this study and key recommendations are presented in this report. The details of the rationale behind the various evaluations and rankings are included in later sections. Additional details of the work performed and the approach taken by AS&M are given below.

Constellation Architecture Elements: AS&M performed a broad assessment survey and study to establish the potential composite materials and structures applications and benefits to the Constellation Program Elements, including the Ares I Launch Vehicle, the Ares V Launch Vehicle, the Orion Crew Exploration Vehicle (CEV), the Lunar Surface Access Module (LSAM), and infrastructure elements at the lunar surface, including rovers, habitats, payload handling devices, resource utilization equipment, and other relevant infrastructure that may benefit from composites technology. Although these surface infrastructure elements are relatively small (as compared to the launch vehicles for example), there is a premium on mass landed at the lunar surface and these elements are likely to benefit significantly from lightweight design technologies.

Technology Classes: Part of this effort was also focused on identifying specific design solutions and classes of composite structure technologies that have an impact across a range the architecture elements. Although AS&M considered architecture elements and composites technologies that are broadly applicable to different classes of structures and specific design solutions, engineering judgment and expertise were used to select the elements and technologies given emphasis in the final report. The broad experience base of the AS&M team members uniquely qualifies the team to perform a non-parochial, independent, unbiased assessment of potential composite technologies and their benefits to NASA's Exploration Architecture. The team included:

- Dr. Darrel R. Tenney, retired NASA, former Chief of Materials Division at Langley;
- Dr. John G. Davis, retired NASA, former Manager of the ACT Program (LaRC);
- Dr. Martin M. Mikulas, retired NASA, former Head of Space Structures Mechanics Branch (LaRC);
- Mr. Harold G. Bush, retired NASA, Senior Research Engineer in Composite Spacecraft Structures and Concepts (LaRC);
- Dr. Norm J. Johnston, retired NASA, former Senior Chemist and Manager, Composites Technology in the Advanced Materials and Processing Branch (LaRC);
- Mr. Brantley R. Hanks, retired NASA, Head, Spacecraft Dynamics Branch (LaRC);
- Dr. R. Byron Pipes, John L. Bray Distinguished Professor of Engineering, Purdue University;
- Mr. Jack F. McGuire, retired Boeing, former Director of Structures Technology Boeing Commercial Airplane Company.

The technologies that were outside the teams acknowledged sphere of expertise were assessed and documented from data collected from other experts or literature surveys.

Evaluation Criteria: The AS&M team evaluated composites technologies and their potential benefit to NASA missions using the following factors (but not limited to): (1) the potential mass, cost, or reliability benefits, (2) the range of architecture elements to which the technology is applicable, (3) the current technology readiness level (TRL), including the heritage of the technology (previous missions, aeronautics applications, etc.), (4) the estimated difficulty and cost of developing the technology, including the timeframe in which the technology could be made available to NASA programs, (5) the risks associated with the technology, and (6) all real and perceived hurdles (especially "long poles") related to implementing the technology.

Technologies of Interest:

During the first phase of this effort a detailed list of key technologies to be considered in this study was developed and agreed on by the NASA and industry teams. This list is shown in the appendix along with specific examples of how these technologies were ranked for different Structural elements found in different parts of the Constellation Program.

Composite Structures "Issues":

The real and perceived issues associated with the expanded use of composite materials in space applications are reminiscent of debates encountered when composites were proposed for primary structural applications in commercial aircraft. A NASA/DOD/Industry/FAA strategy was formulated to systematically remove the real and perceived barriers. The lessons learned from that work can significantly contribute to formulation of a new strategy to remove barriers for expanded application of composites in space structures. The members of the AS&M team were

principle participants in the development and execution of the relevant composites R&D for commercial aircraft. This experience and expertise was used to address the following potential barrier issues listed on Page 8 of the RFP:

- composite materials are expensive
- there is a lack of established design allowables for composite materials
- composites experience corrosion problems when coupled with metals
- composite properties degrade under extreme temperatures
- composite properties degrade in the presence of moisture
- composites exhibit poor energy absorption (susceptible to impact damage, not crashworthy)
- there is limited data on composites in a micrometeoroid environment
- there is often a need for lightning strike protection with composites
- inspection methods for composites are expensive and complex
- it is difficult to detect substandard adhesive bonds in composite structures
- it is difficult to detect the precise location of defects in composite structures
- composite structures are difficult to repair
- it is difficult to maintain hermetic seals (micro-cracking and permeability issues)
- it is difficult to incorporate cutouts and reinforcements without offsetting mass savings
- it is difficult to incorporate secondary structure without offsetting mass savings
- there are problems with CTE mismatches when combining composite and metallic structures

## C. Weight Reduction Calculations for Composite Structures in Constellation Program

Weight predictions were made for: 1. Ares I Upper Stage (US) liquid hydrogen and liquid oxygen tanks, Ares V Earth Departure Stage (EDS) and Core Stage (CS) liquid hydrogen tanks, 2. Ares I Interstage Cylindrical Shell, 3. Lunar Surface Access Module (LSAM), Ascent Module liquid methane tank and 4. Lunar Surface Manipulator. See Figure 1. A brief description of assumptions, methodology and results follows.

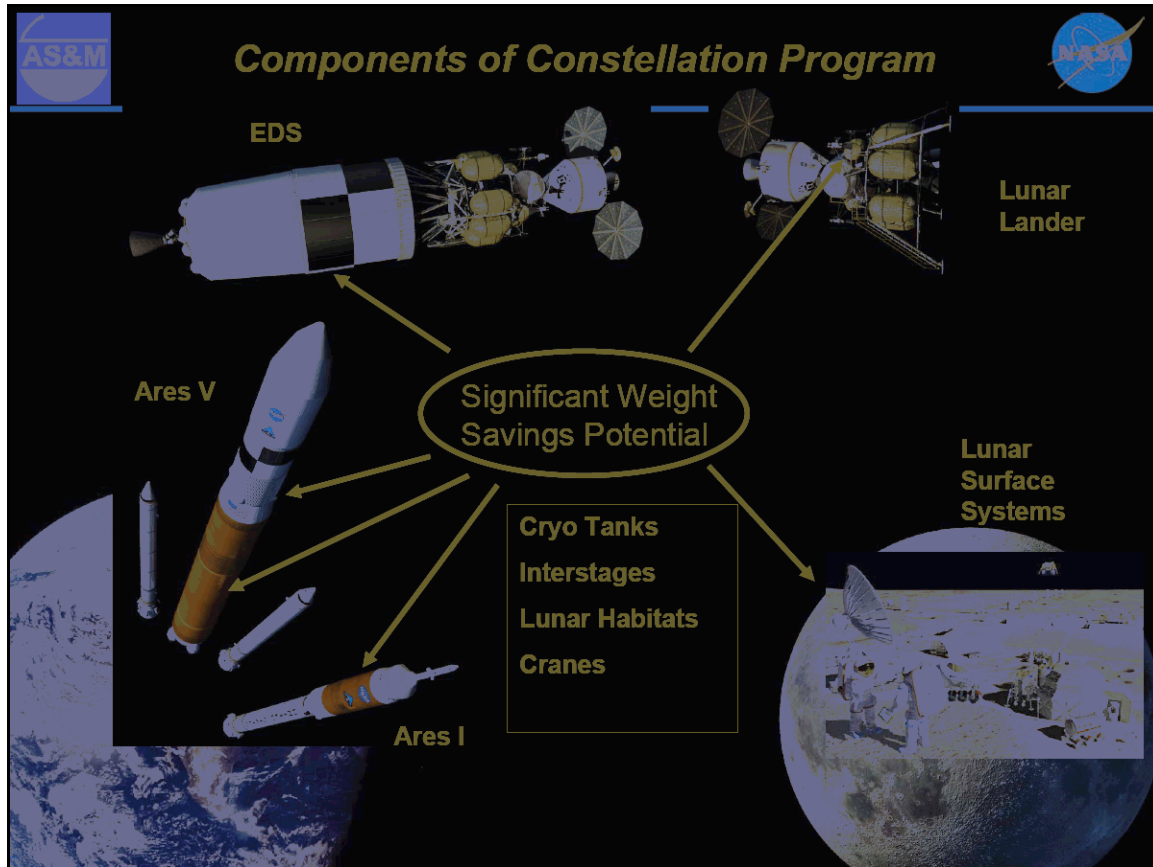


Figure 1 – Components of Constellation Program

### C.1 Ares I Upper Stage and Ares V Earth Departure Stage and Core Stage Cryogenic Propellant Tanks

#### Assumptions

Figure 2 illustrates the Ares I and V tanks considered for application of composite materials. The Aluminum-Lithium Space Shuttle external tank represents State-of-the-Art for metal cryogenic propellant tanks. The DC-XA solid laminate and the Northrop Grumman Next Generation Reusable Launch Vehicle honeycomb sandwich are examples of some of the latest efforts to design and build high quality composite cryogenic propellant tanks. Figure 3 summarizes assumptions

used in estimating tank weights. All tanks designs used in the current study have a cylindrical center section with hemispherical domes.

The Ares I Upper stage has a common bulkhead separating the liquid hydrogen and oxygen tanks. Ares V tanks are separated by a dry Intertank. Equal thickness inter- and outer-face sheet honeycomb core sandwich is the selected structural concept for both the center section and the domes. IM7/977-2 quasi-isotropic lay-up is the face sheet. Mechanical and physical properties for IM7/977-2 were obtained from reference 1. The honeycomb core was assumed to be N636 OX Kevlar 3 pounds per cubic foot 3/16-inch cell. Properties for the honeycomb were obtained from reference 2. FM 300 film, 0.08 pound per square foot, is the adhesive selected to bond the core to face sheet. Properties for FM 300 were obtained from reference 3.

Maximum allowable operating temperature for aluminum and IM7/977-2 are approximately equal. Therefore, thermal insulation weight was assumed to be approximately the same for both composite and metal tanks and thus was not calculated in this task.

Based on examination of detailed weight breakdown for the Space Shuttle External Tank in reference 4, it is valid to assume that the tank wall and domes account for 75-80 percent of the tank structural weight.

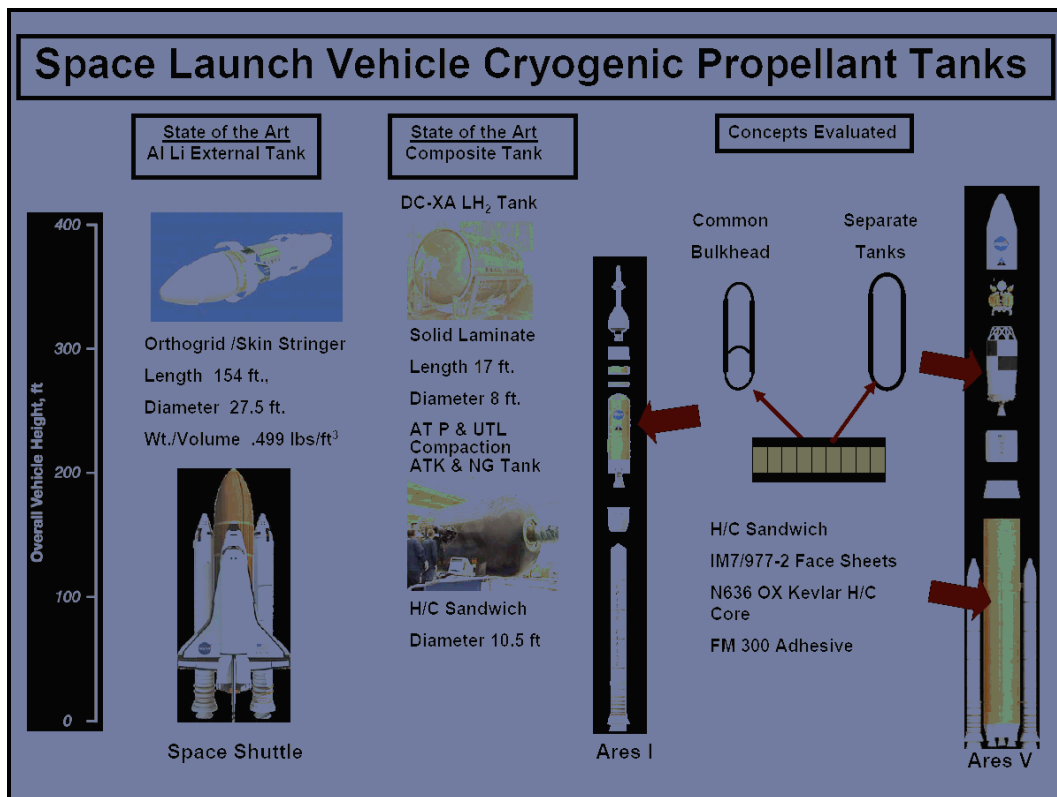
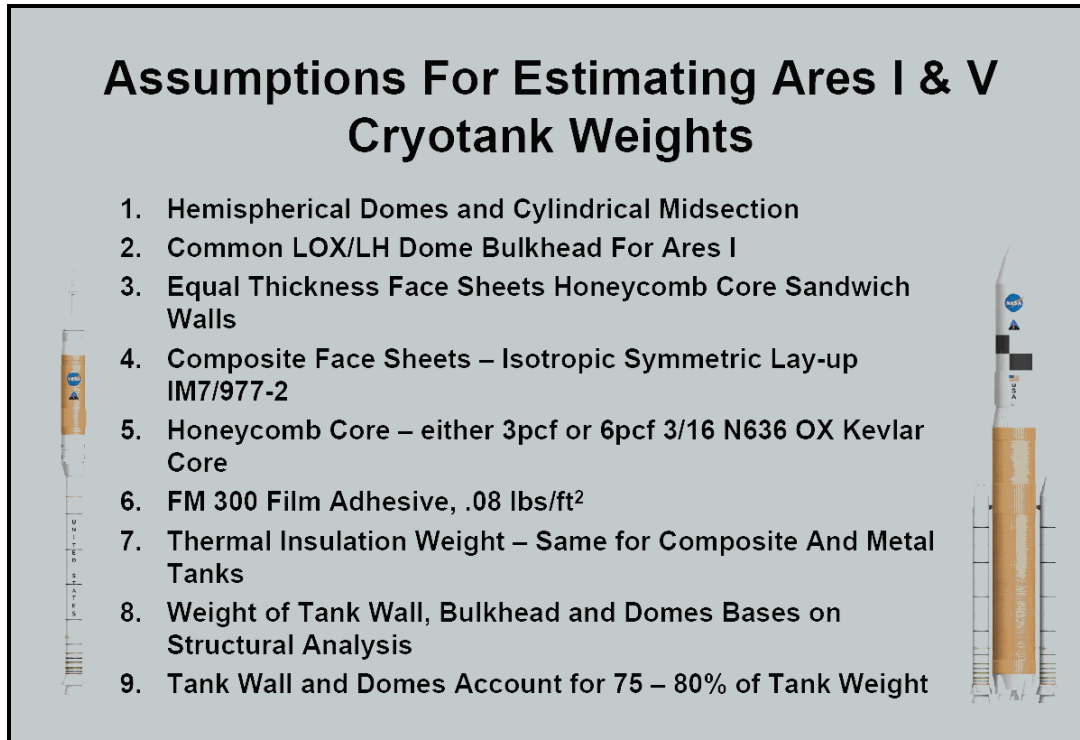


Figure 2 – Space Launch Vehicle Cryogenic Propellant Tanks



**Figure 3 – Assumptions For Estimating Ares I & V Cryotank Weights**

## Methodology

Figure 4 outlines the procedure used to estimate tank weights. The sequence of calculations follows:

1. Tank volume, diameter and length are computed based on required propellant mass and vehicle diameter for each stage which is given in references 5, 6 and 7.
2. Total face sheet thickness required to contain liquid oxygen or liquid hydrogen at design ultimate pressure is computed using membrane theory. Design static head pressure and operating pressure are summed and multiplied by the Safety Factor to compute the design ultimate pressure.
3. Maximum axial compression load along the cylindrical section of the tank was obtained from the Launch Vehicle Analysis Code or other references 8, 9 and 10.
4. Design ultimate axial compression load for the pressurized tank equals load from step 3 minus relief from operating pressure. Total face sheet thickness required to support design ultimate axial compression load without regard to instability is calculated.
5. Honeycomb core thickness is estimated.
6. Local shear crimping, local face wrinkling, intracell buckling and instability of the cylindrical section are computed using equations contained in references 11 and 12.
7. Margins of safety for all failure modes are computed.
8. Face sheet thickness and/or honeycomb core thickness are changed to achieve positive margins and minimum weight.
9. Steps 5 through 7 are repeated until convergence is obtained.
10. Tank weight is computed.

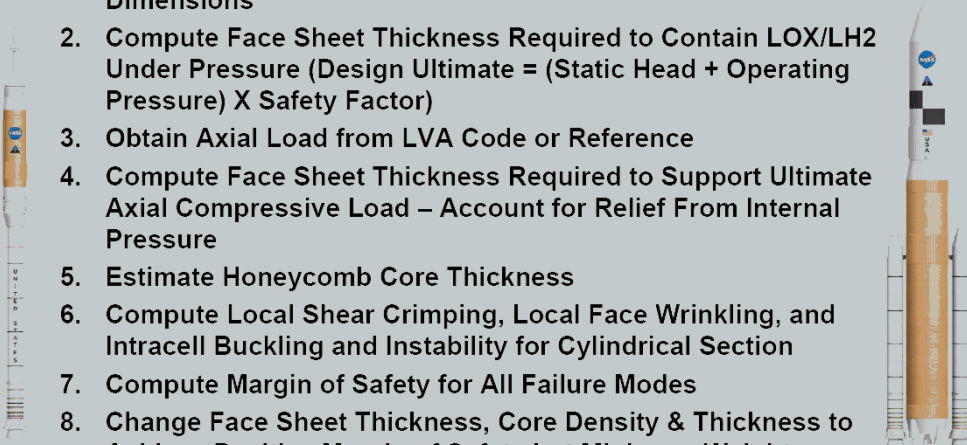
Figure 5 shows the overall shape and key dimensions for the Ares I Upper stage tank. The tank is 63 feet in height and 18 feet in diameter. Design pressure ranges from 50 to 52 psig. Design ultimate axial compression load is 5625 pounds per inch. Face sheets are 0.0528 inches thick and the honeycomb core is 0.947 inches thick. Total weight is 4500 pounds and weight per unit volume is 0.309 pounds per cubic foot.

Figure 6 shows the overall shape and key dimensions for the Ares V Earth Departure Stage (EDS) and Core Stage (CS) liquid hydrogen tanks. The EDS tank is 41 feet in height and 27.5 feet in diameter. Design pressure is 51 psig. Design ultimate axial compression load is 4500 pounds per inch. Face sheets are 0.080 inches thick and the honeycomb core is 0.420 inches thick. Total weight is 3939 pounds and weight per unit volume is 0.213 pounds per cubic foot.

The CS tank is 129 feet in height and 33 feet in diameter. Design pressure is 55 psig. Design ultimate axial compression load is 6750 pounds per inch. Face sheets are 0.1036 inches thick and the honeycomb core is 0.696 inches thick. Total weight is 24283 pounds and weight per unit volume is 0.241 pounds per cubic foot.

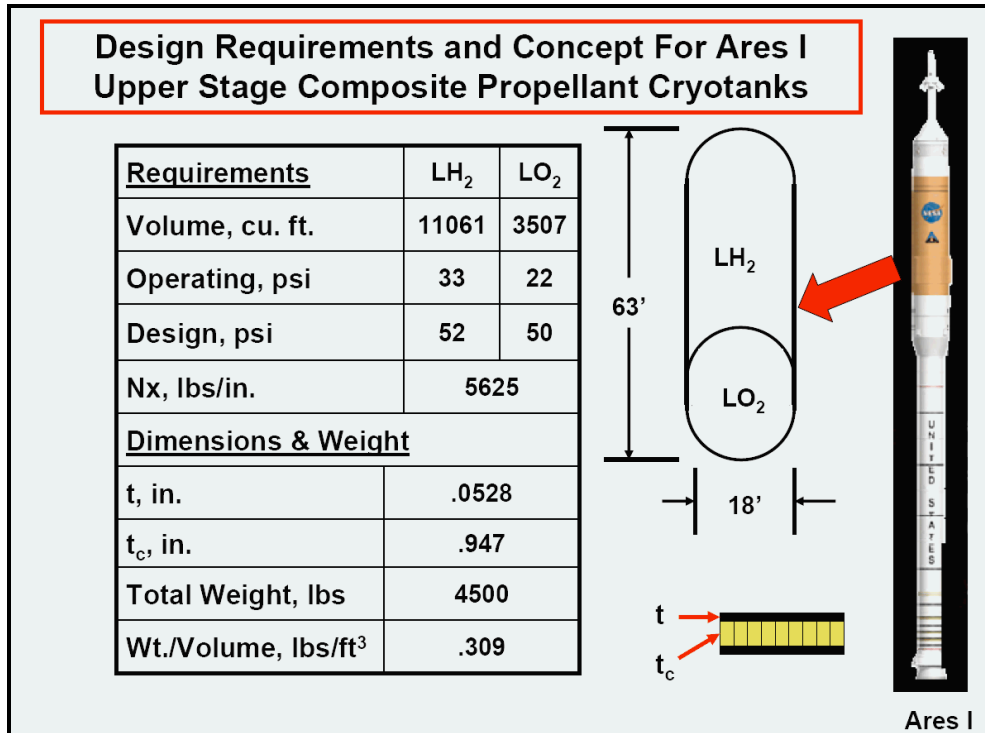
## Methodology For Estimating Ares I & V Cryotank Weights

1. Given Propellant Mass & Vehicle Diameter, Compute Tank Dimensions
2. Compute Face Sheet Thickness Required to Contain LOX/LH2 Under Pressure (Design Ultimate = (Static Head + Operating Pressure) X Safety Factor)
3. Obtain Axial Load from LVA Code or Reference
4. Compute Face Sheet Thickness Required to Support Ultimate Axial Compressive Load – Account for Relief From Internal Pressure
5. Estimate Honeycomb Core Thickness
6. Compute Local Shear Crimping, Local Face Wrinkling, and Intracell Buckling and Instability for Cylindrical Section
7. Compute Margin of Safety for All Failure Modes
8. Change Face Sheet Thickness, Core Density & Thickness to Achieve Positive Margin of Safety but Minimum Weight
9. Repeat Steps 5 Through 7 Until Convergence is Obtained.
10. Compute Final Weight

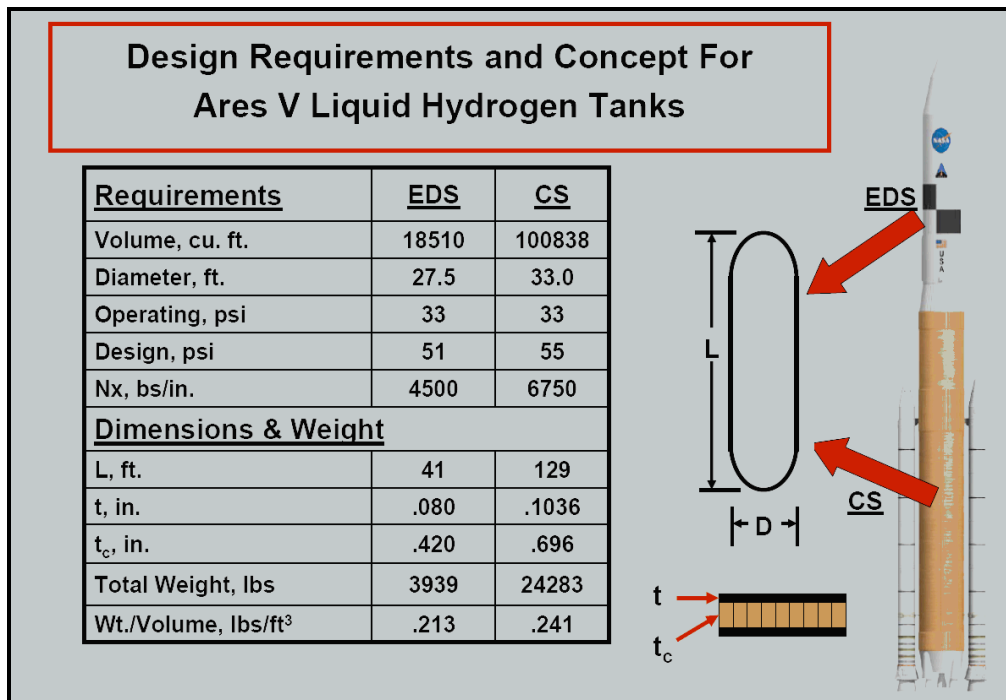


**Figure 4 – Methodology for Estimating Ares I & V Cryotank Weights**





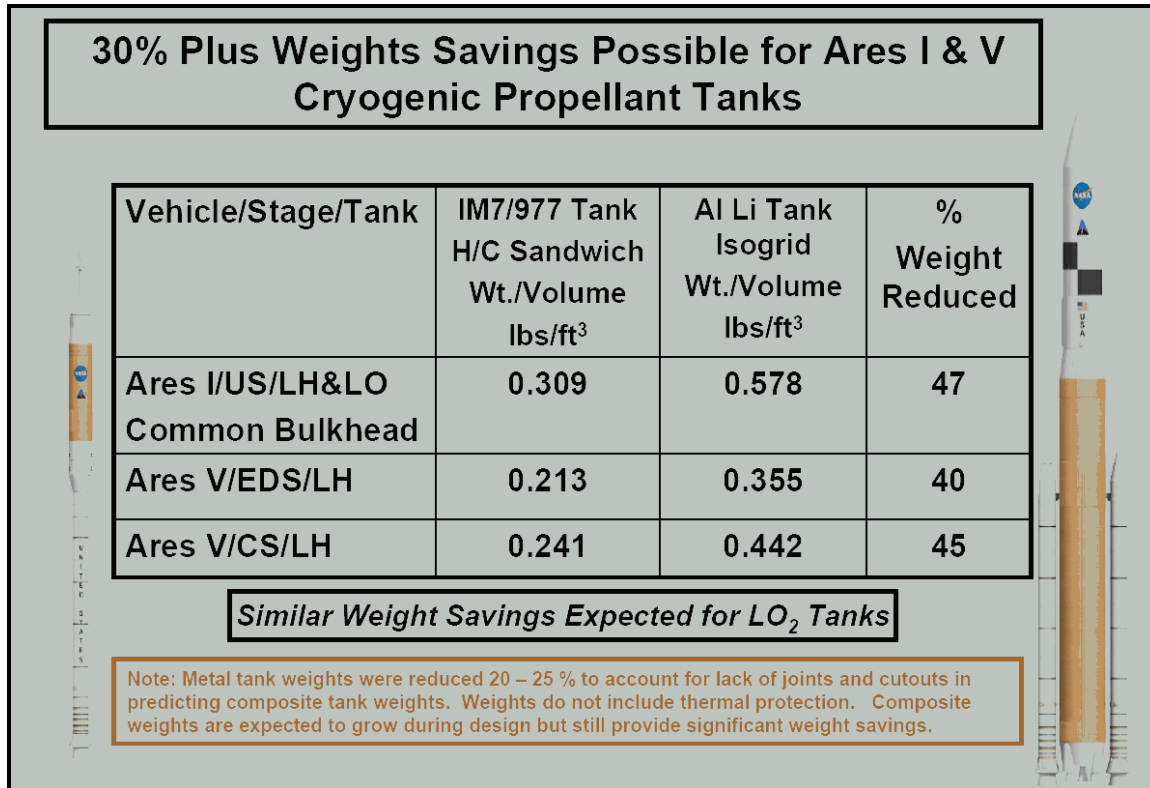
**Figure 5 – Design Requirements and Concept For Ares I Upper Stage Composite Propellant Cryotanks.**



**Figure 6 – Design Requirements and Concept for Ares V Liquid Hydrogen Tanks**

## Results

Figure 7 shows a comparison of predicted weights for IM7/977-2 honeycomb sandwich composite tanks and aluminum lithium isogrid cryogenic propellant tanks. Weights shown for the aluminum lithium tanks have been reduced 20-25 percent from the values predicted in references 8 and 10 to account for joints. Comparison of all data indicates that a weight savings in excess of 30 percent should be achievable. Predicted weight savings on the same order are expected for Ares I and V liquid oxygen tanks.



**Figure 7 – 30% Plus Weight Savings Possible For Ares I & V Cryogenic Propellant Tanks**

All of the composite predictions are based on the assumption that hydrogen permeability and/or microcracking can be maintained at acceptable levels or very light weight barriers can be incorporated in the designs. Ares I tanks can be fabricated in a 30 feet in diameter by 75 feet in length autoclave that exists in the USA, reference 13. Either a non autoclave processing composite that can produce current autoclave quality parts must be developed or a new larger diameter and length autoclave is required to fabricate the Ares V tanks.

## References

1. Dorsey, John T., Myers, David E. and Martin, Carl J., Reusable Launch Vehicles Tank/Intertank Sizing Trade Study, AIAA 2000-1043.
2. The M. C. Gill DOORWAY, Volume 41, Number 3, Summer 2004.
3. FM 300 High Shear Strength Modified Epoxy Film Adhesive, Data Sheet, Cytec Engineering Materials.

4. Design Mass Properties II, "Mass Estimating and Forecasting For Aerospace Vehicles Based on Historical Data, JSC 26098, and Nov. 1994.
5. Jerry Cook, "NASA Ares I Crew launch Vehicle Upper Stage Configuration Selection Process," NASA MSFC.
6. <http://www.nasaspaceflight.com/content/?cid=5013>.
7. Dumbacher, Daniel L., A New Heavy-Lift Capability For Space Exploration: NASA's Ares V Cargo Launch Vehicle.
8. Komar, D. R., Output from LVA Code, LM05 Single Stick Block 2 4sSRB 1xSSME Run 01, 12/12/2007.
9. McGhee, D., Space Launch and Transportation Systems: Design and Operations, MSFC Course, Chapter 9.2, Vehicle Loads Analysis, Chart 55.
10. Komar, D. R., Output from LVA Code, Lunar-Mars Block 2 InLine Cargo - SSME<sub>x5</sub> 5sSRB - 600 Max Q, 12/12/2007.
11. HexWeb™ Honeycomb Sandwich Design Technology, Publication No. AGU 075b, Hexcel Composites, Duxford, December 2000.
12. Bruhn, E. F., Analysis and Design of Flight Vehicle Structures, Tri-State Offset Company, 1965.
13. <http://www.aschome.com/WorldsLargestAutoclave2.htm>.

## C.2 Ares I Interstage Cylindrical Shell

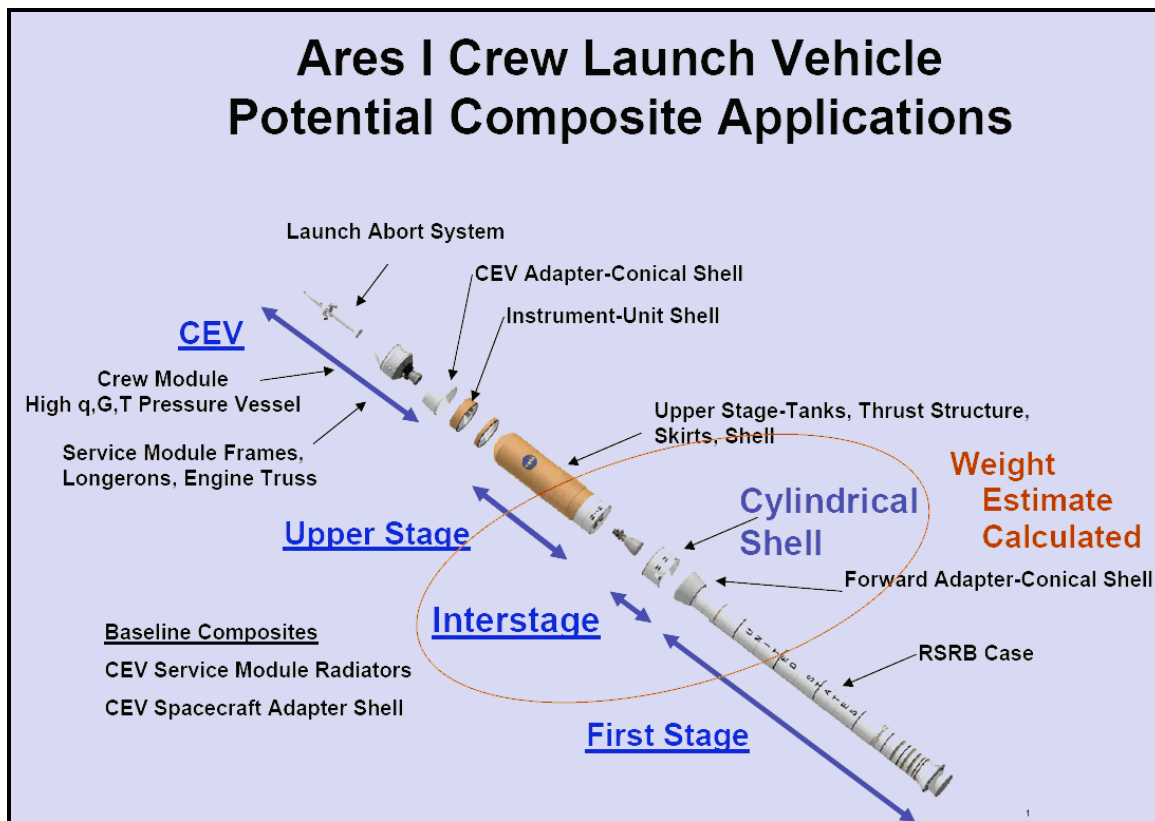


Figure 8 – Ares I Crew Launch Vehicle Potential Composite Applications

## **Assumptions**

Figure 8 illustrates the Ares I Interstage location. The Interstage was modeled as a circular cylinder without cutouts loaded in uniform axial compression. Cylinder length and radius are 225 inches and 108 inches, respectively.

## **Methodology**

Theoretical cylinder buckling load was predicted by analysis from reference 1. Buckling load was knocked down to 55 percent of theoretical value and results were compared with cylinder optimization results from reference 2. Both aluminum and IM7/977-2 honeycomb sandwich concepts were analyzed. Optimum laminate lay up was pseudo-isotropic.

## **Results**

Figures 9 through 12 provide a brief summary of potential mass savings from applying composite structures to the Ares I Interstage. Figure 10 lists face sheet thickness, core thickness and predicted weight for each concept. A 25 percent weight savings is indicated. Figures 11 and 12 compare efficiency of various stiffened and unstiffened cylinders. Note that log-log scales are used and that small a change in position indicates large changes in weight.

Damage tolerance and/or minimum gage are key issues that need to be demonstrated for this application to be viable.

## **ARES I Interstage Mass Savings Example**

### **Approach**

- ◆ Selected ARES I inter-stage as an example of mass savings that could be obtained from numerous cylindrical structures in the Constellation program
- ◆ Sandwich concept selected as example

### **Methodology**

- ◆ Design procedure involves integrated laminate analysis and cylinder buckling spreadsheet
- ◆ Cylinder buckling analysis from Robert Jones paper
- ◆ Buckling load knocked down to 55% of theoretical value
- ◆ Compare with 1977 Agarwal cylinder optimization results

### **Results**

- ◆ Optimum laminate lay up for cylinder buckling was found to be pseudo-isotropic
- ◆ Composite mass savings were 25% compared with aluminum

Figure 9 – Ares I Interstage Mass Savings Examples

## **ARES I Interstage Example Results**

**(Radius = 108", Length = 225")**

**(Aluminum 5 lb/ft<sup>3</sup> core)**

### **Aluminum Facesheets**

$$t_{\text{face}} = 0.05", \quad t_{\text{core}} = 1", \quad \Rightarrow \quad W/A = 1.8 \text{ lb/ft}^2$$

### **IM7/977-2 Pseudo-Isotropic Facesheets**

$$t_{\text{face}} = 0.044", \quad t_{\text{core}} = 1.45", \quad \Rightarrow \quad W/A = 1.36 \text{ lb/ft}^2 \quad \Rightarrow \quad 25 \% \text{ Weight savings}$$

Figure 10 – Ares I Interstage Example Results

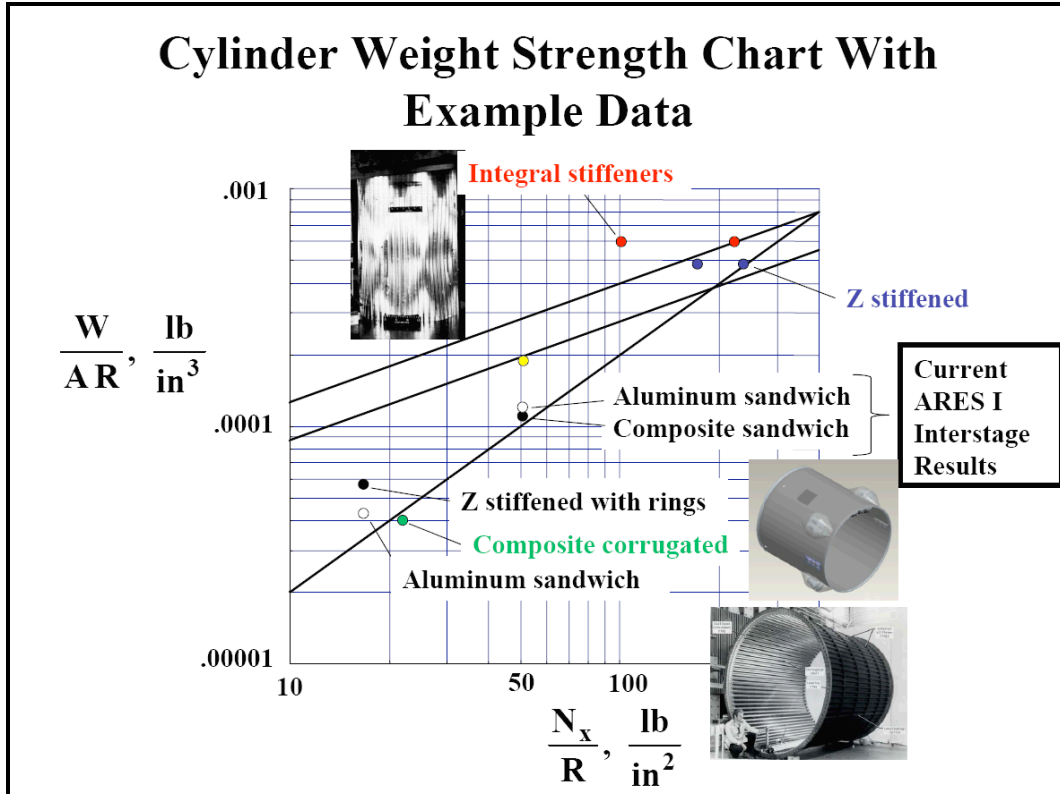


Figure 11 – Cylinder Weight Strength Chart With Example Data

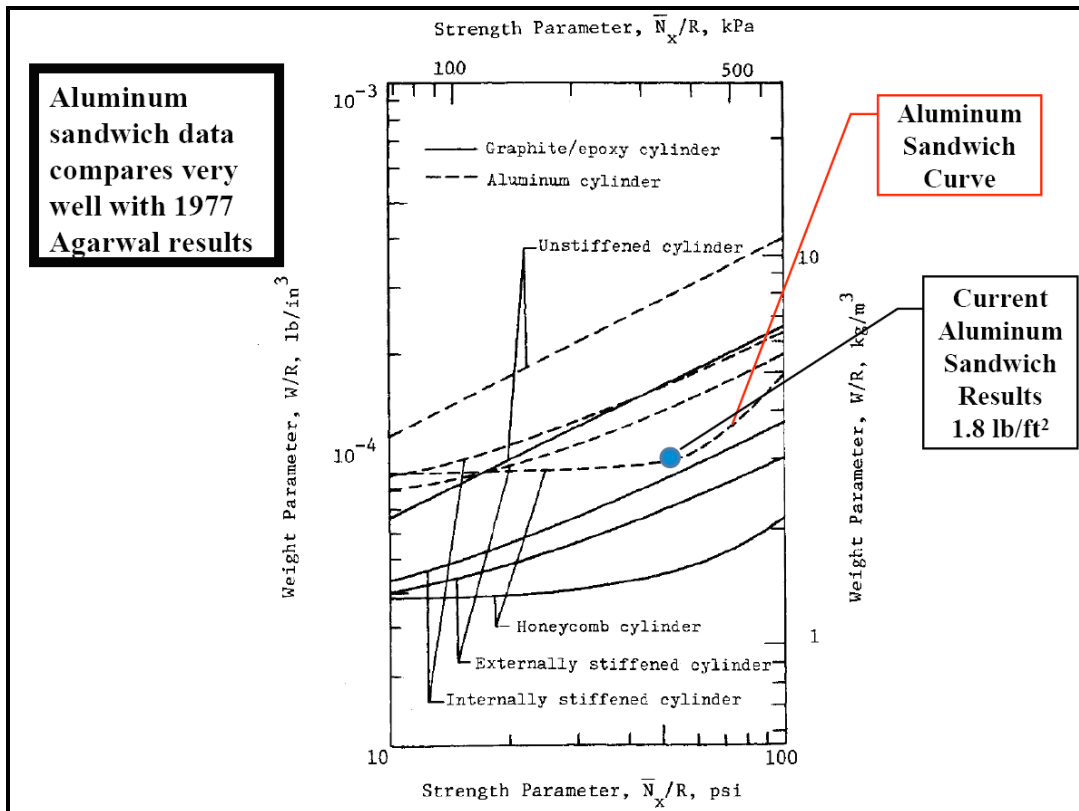


Figure 12 – Comparison of Aluminum Sandwich Interstage Predictions With Earlier Predictions

## References

1. Robert M. Jones and Harold S. Morgan, Buckling and Vibration of Cross-Ply Laminated Circular Cylindrical Shells, AIAA Journal Vol. 13, No. 5, May 1975.
2. B. L. Agarwal, *Northrop Corp., Hawthorne, Calif.* and L. H. Sobel, *Westinghouse Electric Corp., Madison, Pa.* Weight Comparisons of Optimized Stiffened, Unstiffened, and Sandwich Cylindrical Shells, J. Aircraft Vol. 14, No. 10, October, 1977.

## C.3 Lunar Surface Access Module (LSAM) Ascent Module Liquid Methane Tank

An in-depth assessment of composite structures for cryotanks on the LSAM Ascent Module is contained in Appendix A-4. A brief summary follows.

### Assumptions

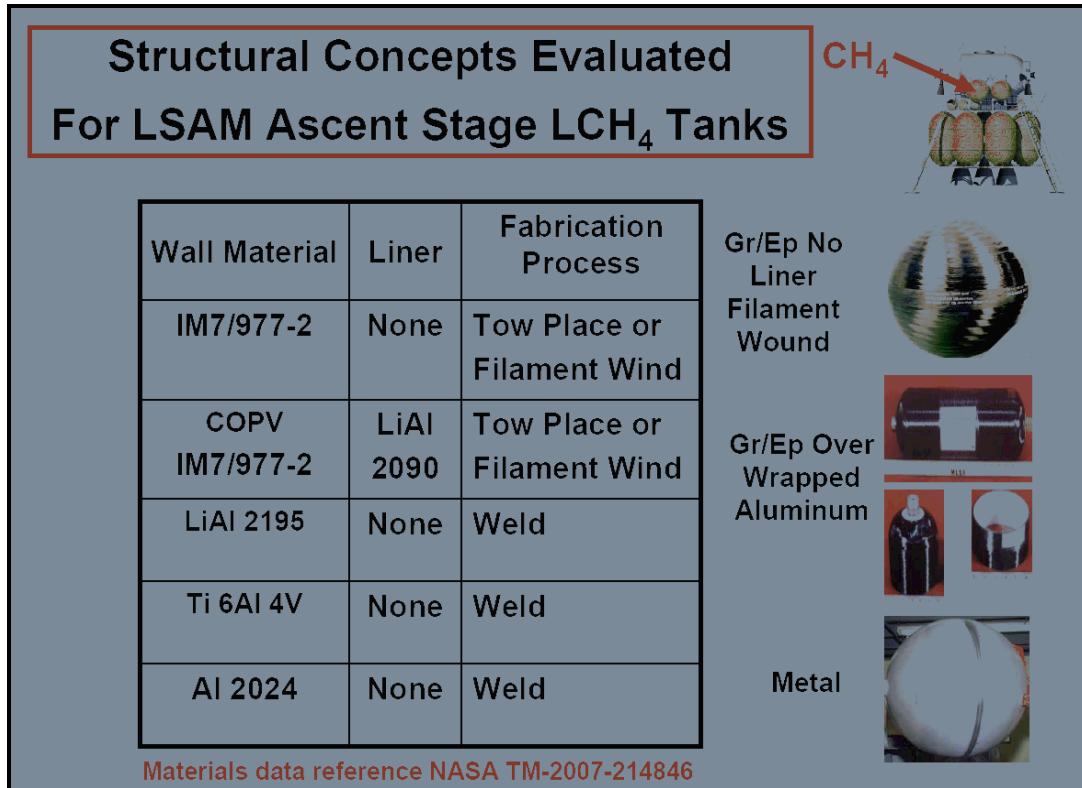
Figures 13 and 14 illustrate the propellant tanks on the LSAM Descent and Ascent Stages and list requirements and assumptions. A liquid methane tank on the Ascent Stage was selected for evaluation in this study. A composite tank, composite over wrapped metal liner vessel (COPV), and metal tanks were analyzed. A uniform, unstiffened wall, spherical shaped was selected for all designs. A quasi-isotropic lay up pattern was also selected. Mechanical and physical properties used in weight calculations were obtained from reference 1. Composite and COPV tanks are expected to be fabricated by tow placement or filament winding. Cure would occur in an autoclave.

Requirements for the liquid methane tank are based on information contained in references 2 and 3. Pumping, gauging and end boss weights are not included in estimates. Maximum allowable operating temperature for aluminum and IM7/977-2 are approximately equal. Therefore, thermal insulation weight is assumed to be approximately the same for both composite and metal tanks and thus was not calculated.

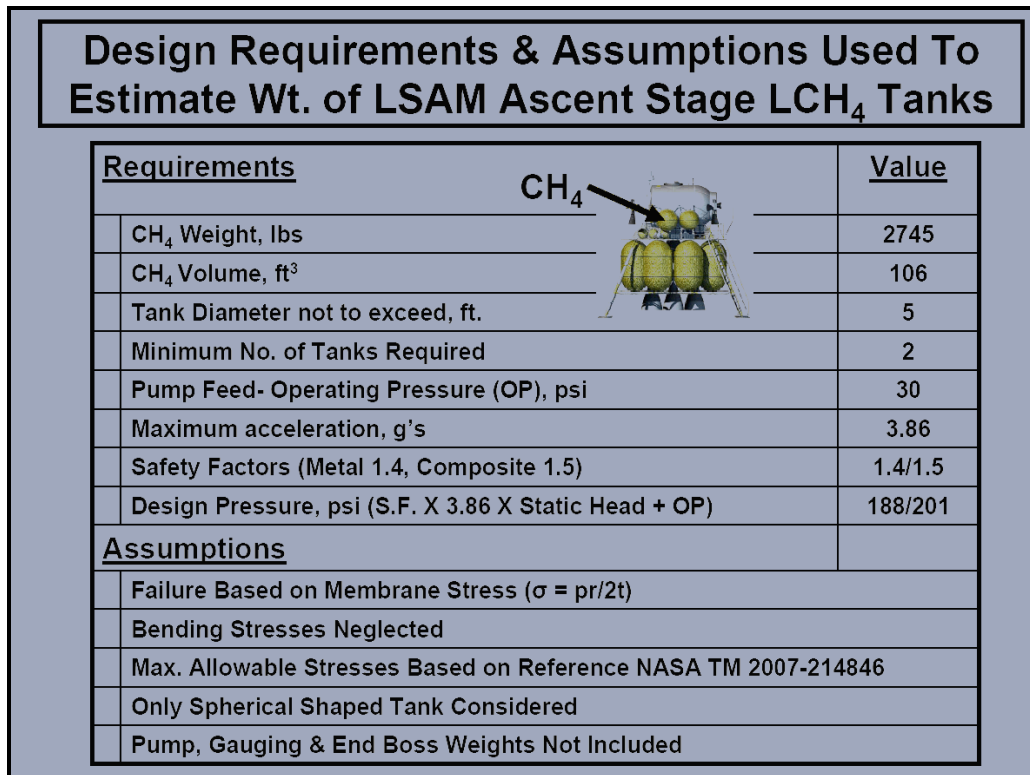
### Methodology

The sequence of calculations used to estimate weight follows:

1. Tank volume, diameter and length are computed based on required propellant mass and vehicle diameter for each stage is given in reference 2.
2. Total face sheet thickness required to contain liquid methane at design ultimate pressure is computed using membrane theory. Design static head pressure and operating pressure are summed and multiplied by the Safety Factor to compute the design ultimate pressure. Note that a larger Safety Factor is used for composite tanks.
3. Tank weight is computed.



**Figure 13 – Structural Concepts Evaluated For LSAM Ascent Stage LCH<sub>4</sub> Tanks**

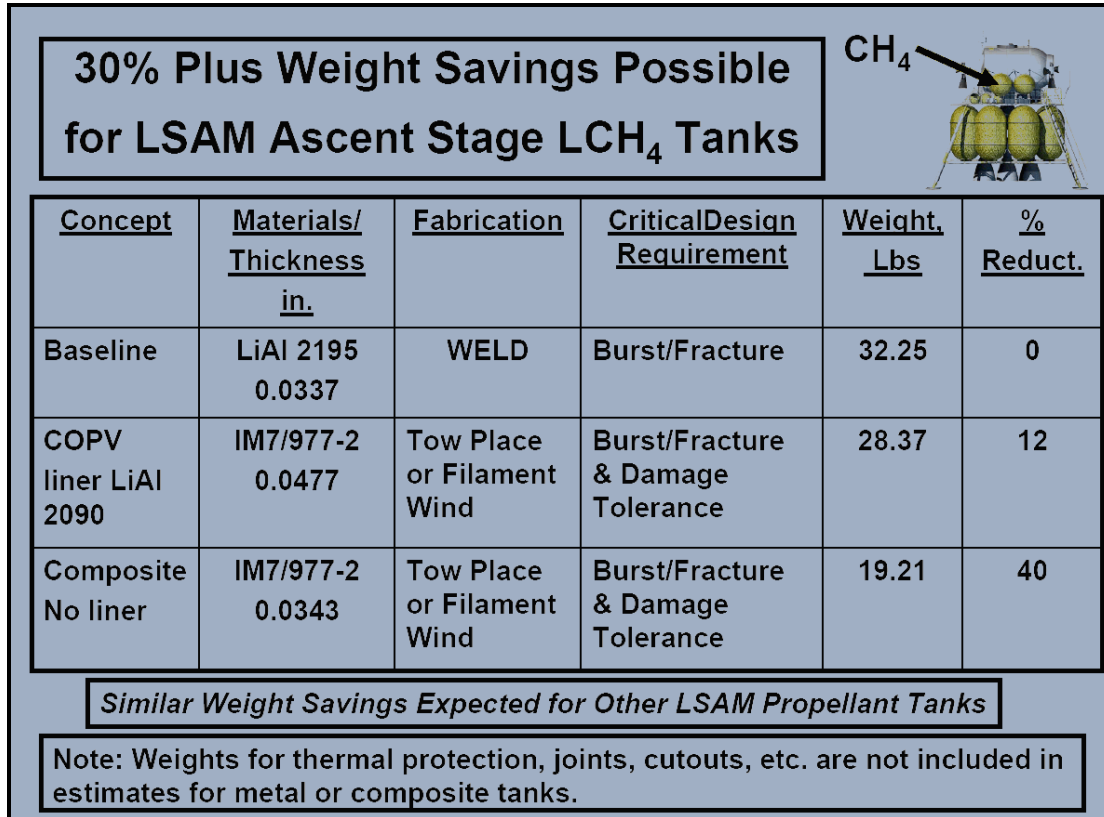


**Figure 14 – Design Requirements & Assumptions Used to Estimate Weight of LSAM Ascent Stage LCH<sub>4</sub> Tanks**



## Results

Figure 15 shows the weights calculated for LiAl, IM7/977-2 over wrapped LiAl and IM7/977-2 tanks. Comparison of the predictions indicates a very significant advantage for the IM7/977-2 tank over the COPV or LiAl. The technical barriers to achieving a weight savings in excess of 30% will be: limiting permeability and/or microcracking to acceptable levels and demonstrating that a 0.0343 inch thick wall will have sufficient damage tolerance for this application. More details are contained in Appendix B.



**Figure 15 – Weight Savings of 30% Plus Possible for LSAM Ascent Stage LCH<sub>4</sub> Tanks**

## References

1. Arnold, Steven M, et al., Spherical Cryogenic Hydrogen Tank Preliminary Design Trade Studies. NASA Technical Memorandum-214846, October 2007.
2. John Connolly, Kickin' up some dust, Feb. 20, 2007.
3. Keith Belvin, Lunar Lander Study, Sept. 25, 2007.

## C-4. Lunar Surface Manipulator

### Assumptions

Over the past two years, Langley Research Center initiated an in-depth study of efficient manipulators for conducting Lunar surface operations, see reference 1. Figure 16 describes the ap-

proach, methodology and results of examining a moderate size crane. The device as shown in Figure 17 represents a good case study because the design involves the application of novel structural concepts as well as advanced composites.

## **Methodology**

A moderate size crane with the follow key characteristics was selected: 15 meter reach and 6000 kg payload. Lateral buckling is the primary failure mode. The design procedure used closed-form analyses updated with finite element results.

### **Lunar Surface Structures Mass Savings Example**

#### **Approach**

- Selected Lunar crane as an example since it demonstrates mass savings from advanced concepts as well as from composites
- Boom concept could be basic efficient building block for other Lunar surface structural applications

#### **Methodology**

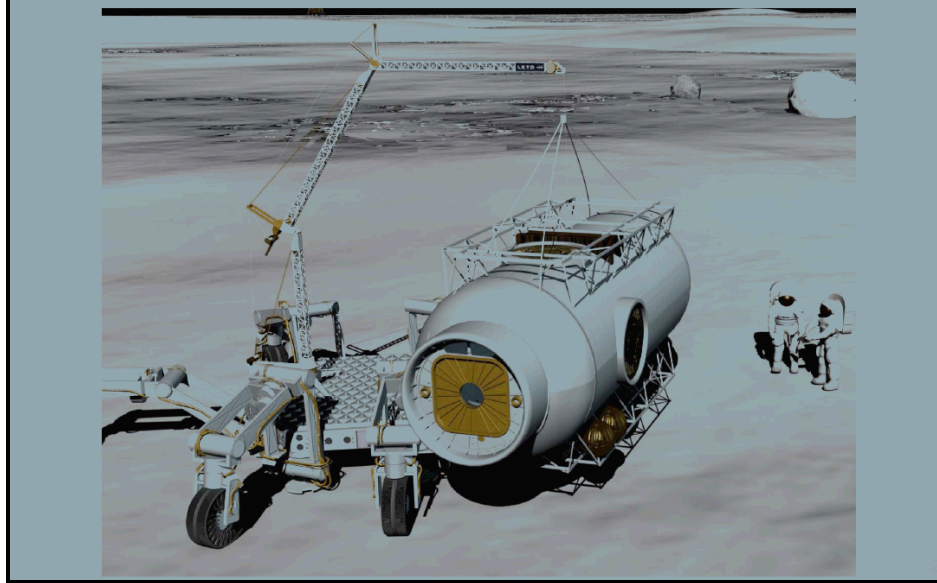
- Moderate size crane selected, Reach = 15 meters, Payload = 6000 kg
- Design procedure involves closed-form analyses updated with finite element results
- Lateral buckling of crane is primary failure mode

#### **Results**

- Motor/gear actuators are major mass driver
- Changing concepts from a simple cantilever boom to a cable supported boom reduces mass by an order of magnitude
- The use of composites provides ~30% mass savings

**Figure 16 – Lunar Surface Structures Mass Savings Example**

## Manipulator Arm Demonstrates High Payoff for Advanced Composites and Truss Structures



**Figure 17 – Manipulator Arm Demonstrates High Payoff for Advanced Composites and Truss Structures**

### Results

A summary of Manipulator masses for different technologies is shown in figure 18. The left hand two bars represent the masses of a simple manipulator arm cantilevered from the root. In this design, the major portion of the mass is in the root actuator that must provide a moment of sufficient magnitude to support and maneuver the tip mass. Since the structural mass is a small portion of the total, switching to composites from aluminum only results in a 15 % mass savings. As shown by the two right hand bars, the manipulator mass is dramatically reduced by changing structural concepts. Switching to a cable stiffened structure reduces the manipulator mass nearly an order of magnitude. This is primarily because of the highly improved mechanical advantage that the offset cable provides. Introducing a truss as the structure for the arm provides an additional factor of two mass savings. For both of the right hand bars, the composite mass savings is about 30%. In figure 19, the various elements of the manipulator are shown. To achieve high efficiency for the manipulator, advances are needed in rods, cables, joints, and deployable trusses. These same structural elements will provide weight savings for a number of different Lunar surface structures such as solar shelters, regolith support structures for radiation shielding, antennas, bridges, etc. In figure 20, a deployable beam merit performance chart from reference 2 is presented. This chart provides a rational means for comparing the efficiency of various beam concepts and can be used to ensure that only the most efficient beam structures are developed. The two green points on the chart represent truss designs for the manipulator arm for two different values of composite modulus. As can be seen on the chart, a 40 msi modulus material beam is twice as efficient as a 20 msi composite beam. It also has the additional advantage of being 30 % smaller in diameter which provides more compact packaging. It is highly recommended that a performance metric chart be developed for each type of surface element to ensure only efficient

devices are developed and to guide the technology program. The lander can currently deliver less than 2/3 of the required mission payload which makes the mass savings critical, see reference 3.

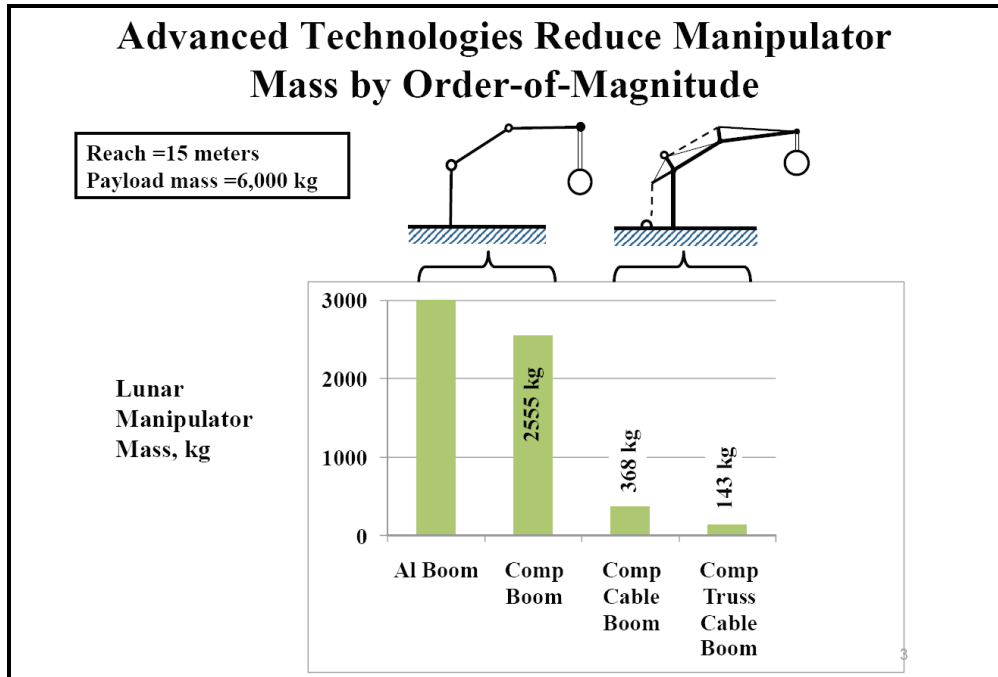


Figure 18 – Advanced Technologies Reduce Manipulator Mass by Order-of-Magnitude

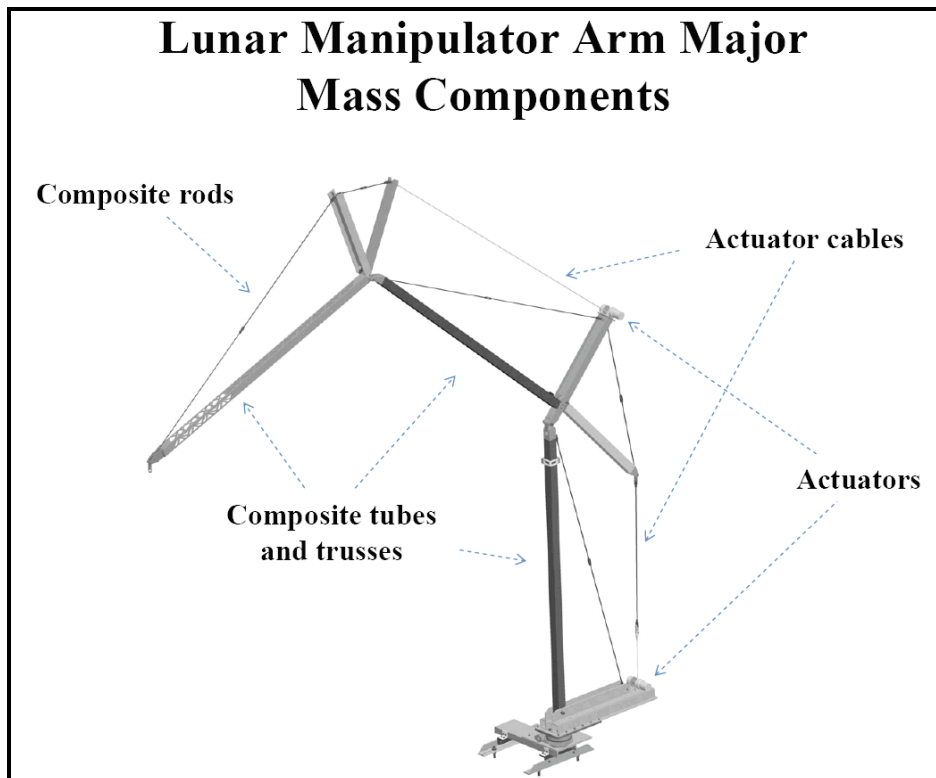


Figure 19 – Lunar Manipulator Arm Major Mass Components

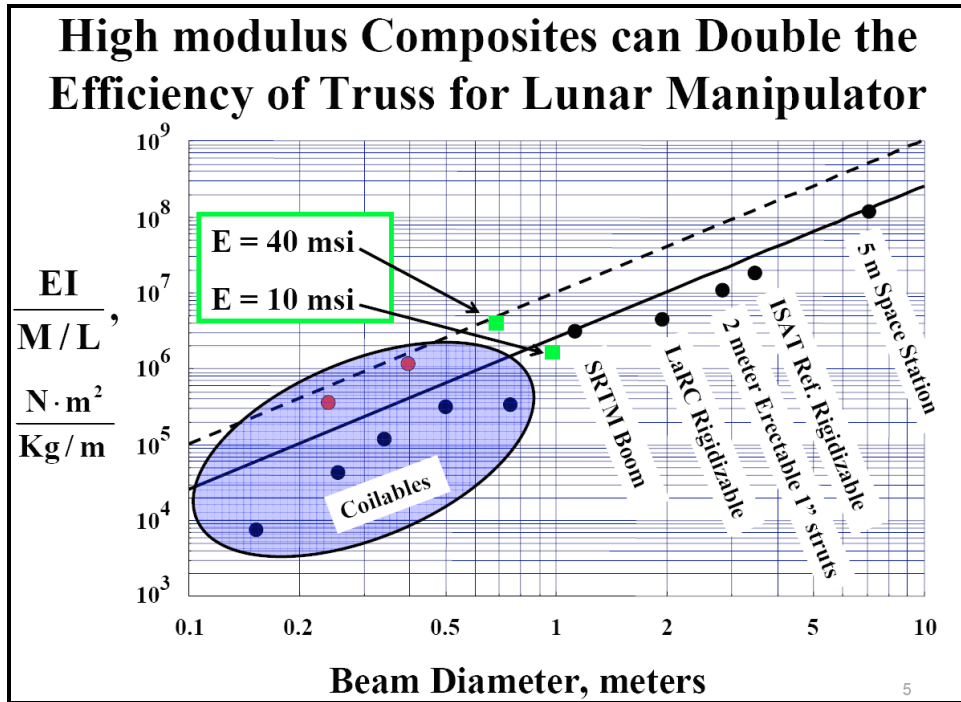


Figure 20 – High Modulus Composites Can Double the Efficiency of Truss for Manipulator

## References

1. Doggett, William, Dorsey, John, Collins, Tim, King, Bruce, and Mikulas, Martin. A Versatile Lifting Device for Lunar Surface Payload Handling, Inspection & Regolith Transport Operations, 2007.
2. Mikulas, Martin, Timothy J. Collins, William Doggett, John Dorsey, and Judith Watson, "Truss Performance and Packaging Metrics," Proceedings of Space Technology and Applications International Forum (STAIF-2006), edited by M. El-Genk, American Institute of Physics, Melville, New York, 2006.
3. Flight International (12/19, Coppinger) reported, "NASA's Altair Lunar Lander project office has started its Lunar Design Analysis Cycle (LDAC)-1 'delta' process to improve payload capability after" the project's Lunar Architecture Team (LAT) "concluded its LDAC-1 Lander would deliver less than two-thirds of the" 13,200 pounds of capability that the mission currently requires. The payload includes consumables, "regolith movers, for launch pad blast berm construction, solar and surface shields, for liquid oxygen (LOX) and methane (CH4) storage, and spent Lander descent module surface transportation." Efforts to increase the Lander's payload capacity include "examining truss and panel construction alternatives for optimizing descent module mass," and could mean the difference between choosing "an aluminum or titanium honeycomb core" for the spacecraft's structural panels. Additionally, NASA studies "concluded that up to 252kg of hydrogen could be 'scavenged' from...abandoned descent modules, and" noted that "one LAT option is for a habitat Lander to be launched on an uncrewed mission." Flight International noted that the current plan "sees the Lunar Lander launched without electrical power," using the Orion crew exploration vehicle until "24 hours before lunar orbit injection."

## D. Technology Assessment Process

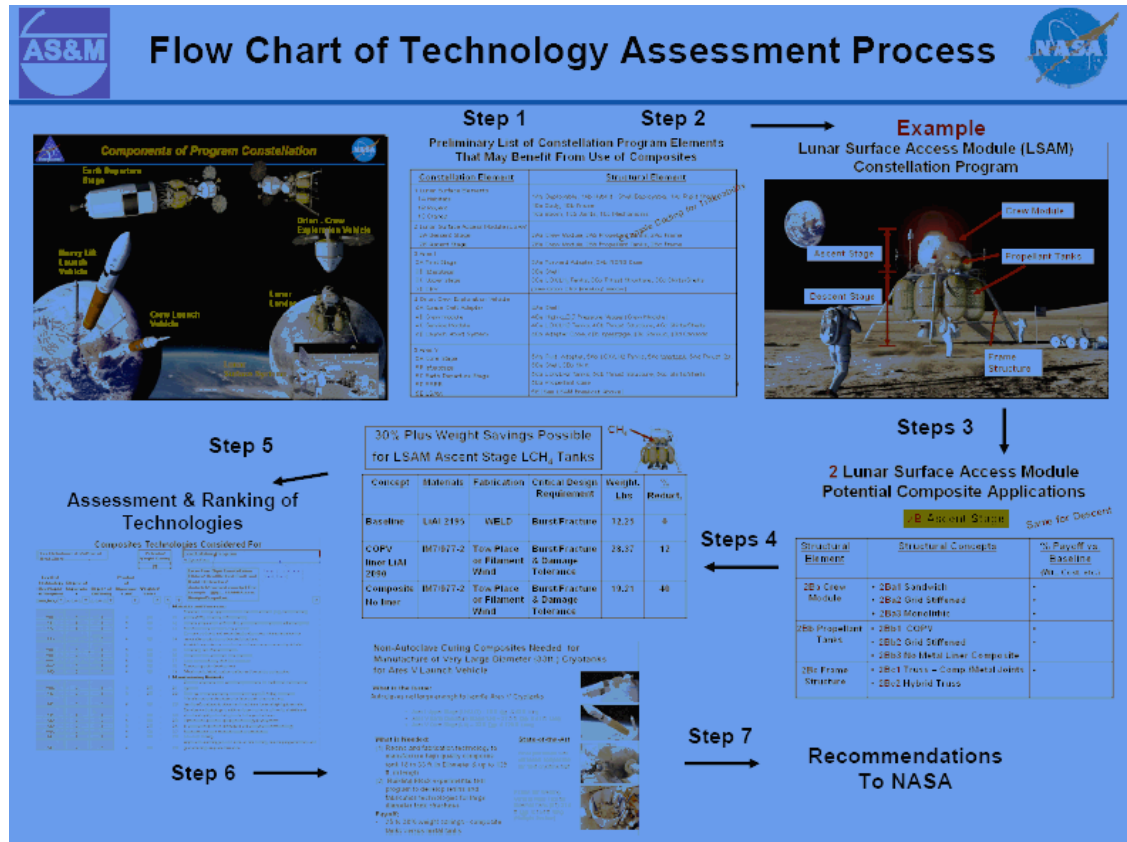


Figure 21 – Flow Chart of Technology Assessment Process

### D.1 Spreadsheet Rating Process

The overall process used to evaluate composite structures technologies for application to NASA’s Vision for Space Exploration is depicted in figure 21. The first step in this process was to examine all the major elements of the Constellation Program to identify the principle structural elements and leading structural concepts for composite applications to the Constellation Program. The major factors used in performing this assessment were:

1. Applications where high values of  $\sigma/\rho$ ,  $E1/2/\rho$ ,  $E1/3/\rho$  would be most beneficial to minimize weight
2. Efficient fabrication of lightweight simple or compound curvature components could be achieved in reasonable time frame
3. Broad area applications were likely
4. Concepts where benefits of composites have been demonstrated in past applications
5. Primary structural components where benefits could be quantified

A complete breakout of the structural concepts and structural elements examined for each major element of the Constellation Program are shown in Appendix A.1.

The next step in our process was to perform detailed assessments of weight savings potential of selected concepts as illustrated in the last section. To do this a “storyboard” approach was used

as illustrated in Appendix A-4 for the Lightweight Composite Propellant Tanks for the Lunar Surface Access Module (LSAM). The major steps in this process were:

- Calculating weight saving potential
- Ranking of critical technologies
- Identification of major technology barriers
- Developing proposed solutions to mature technology

A listing of the 88 (NASA and Industry agreed on) technologies evaluated and the spreadsheet approach used for these evaluations are presented in Appendix A-2. The major factors used to rank the technologies were: (1) level of technology development required, (2) degree of importance, and (3) degree of difficulty to mature the technology in time to impact the Constellation Program. Weighted scores were calculated by multiplying the degree of difficulty score by the degree of importance score and then multiplying that score by a potential weight saving score which resulted from the weight saving calculations discussed in section C. The spreadsheet was programmed to calculate weighted scores and to facilitate sorting into separate sheets that showed:

1. All the data as input
2. R&D only – Technologies judged to require additional R&D to mature for application
3. ND – Technologies that could be matured as part of a typical development project
4. R&D Highest Scores – The top rated R&D technologies for the application being evaluated.

An example of the evaluation sheets completed for the Ares I Upper Stage Cryotanks, Common Bulkhead Tank Concept, Sandwich Structural Concept (3Ca1 – Constellation Traceability Code) is shown in Appendix A-3.

The last step in the technology assessment process was to identify the principle barriers to application of composites in different structural elements and to propose solution to resolve these barrier issues. After studying all the major elements of the Constellation Program, doing weight saving estimates on five different structures, and examining the technology issues associated with these elements, and reviewing numerous publications and presentations our team selected what we considered to be the most significant technologies requiring additional R&D development.

## **D.2 Top Rated Technologies**

The top rated technologies were:

- Low Permeability Microcrack Resistant Resins/Composites
- Non-autoclave Cure Composites for Large Tanks
- NDE Inspection Technologies
- Structural Health Monitoring (SHM)
- Adhesive Bonding Technology for Extreme Temp. Environments
- Low Mass Deployable and Inflatable Structures and Materials for Lunar Surface Applications
- High Fidelity Structural Analyses
- Rapid Conceptual Design Methodology
- Smart Space Composites Design Guide

Each of these technology areas are addressed in more detail in the following section including specific recommendations for additional work.

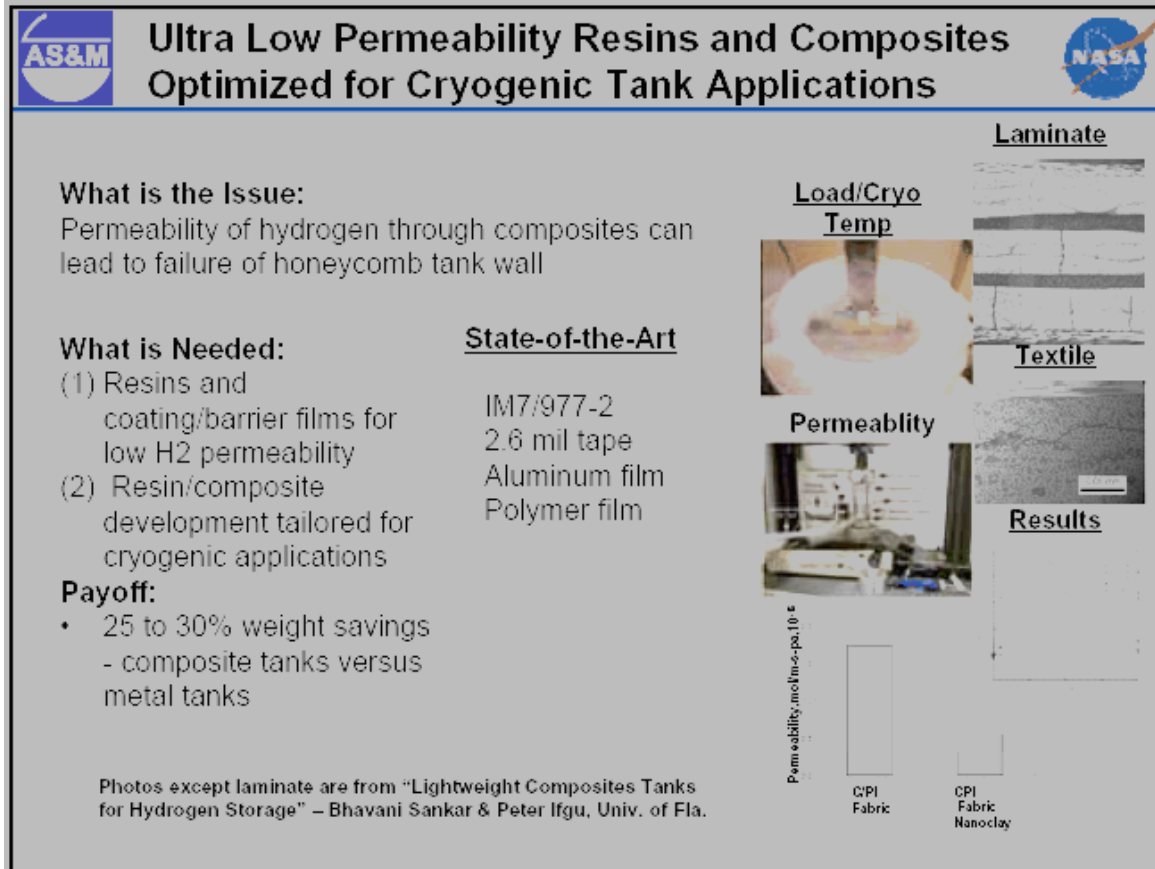
## **E. Issues-Needs-Payoff & Recommended Future Research For Highest Priority Technologies**

The following technologies were identified as the highest priority for expanding the use of advanced composites in the structural elements of the Constellation Program. In this section the basic issues to be addressed, the needs and the potential payoff from doing this work are discussed. R&D recommendation for removing barriers and increasing the technology readiness level of the key technologies to the point where they can be ready for application in constellation program structures are presented.

1. Low Permeability Microcrack Resistant Resins/Composites
2. Non-autoclave Cure Composites for Large Tanks
3. Non-Destructive Evaluation (NDE) of Composites
4. Structural Health Monitoring (SHM)
5. Adhesive Bonding Technology for Extreme Temp. Environments
6. Lunar Surface Systems
7. High Fidelity Structural Analyses
8. Rapid Conceptual Design Methodology (RCDM)
9. Smart Space Composites Design Guide



## E.1 Low Permeability Microcrack Resistant Resins and Composites



**Figure 22 – Low Permeability Microcrack Resistant Resins and Composites for Cryogenic Tank**

### a. Issue, Needs and Payoff

An important consideration for the cryogenic tank design is the selection of the structural tank wall material. The high specific strength, especially at cryogenic temperatures, is the most important parameter for a structural tank wall material. Other important tank wall material parameters are fracture toughness and stiffness. In addition, the tank wall material needs to provide the required permeation resistance to liquid and gaseous hydrogen. S.K. Mittal reviewed the cryogenic tank materials, structural design and insulation systems, reference 1. Potential wall material candidates that offer high specific strength are monolithic metals as well as polymer matrix composites and discontinuously reinforced metal matrix composites. Among these, the use of polymer matrix composite materials for the tank walls has a 25 to 30% weight advantage over conventional metallic designs. However, one of the impediments to the use of composite materials for cryogenic tanks is gaseous permeation through the composite. The X-33 tank failure was caused by expansion of gas that had accumulated in the honeycomb core and expanded when the tank warmed after a cold soak. Significant strides have been made in tank fabrication procedures and in using honeycomb that is perforated to prevent localized build up of gas in the core. However, additional work is needed to develop cryogenically tough composites with resins that do not microcrack and also have inherently low hydrogen permeability. Several promising approaches to reducing hydrogen permeability have been explored including the addition of small

percentages of nanoclay particles in the resin, use of barrier films and coatings and examining the role of crystallinity. Development and testing of low permeability and microcrack resistant composites is key to achieving highly reliable light weight composite cryogenic tanks.

## **b. Barrier Film**

The permeation by hydrogen is perhaps the most critical issue in cryogenic tank design. Hydrogen permeation rates for metals are generally orders of magnitude lower than permeability rates for nonmetallic materials. However, because of density differences, metallic tanks will generally be heavier than composite tanks. A Polymer Matrix Composite (PMC) tank using a thin metallic liner is also another approach to solving the permeability problem, but the additional weight of the liner negates much of the composite tank weight savings. Furthermore, the coefficient of thermal expansion (CTE) mismatch between the composite tank wall and the metallic liner results in inducing stresses in the material that can result in separation of the liner from the tank and/or fracture of the liner, thus making such a design undesirable.

Hydrogen permeation studies performed during the National Aerospace Plane program were encouraging, and it was shown that composite tanks without any liner were sufficiently impermeable to be viable tank materials. However, the failure of the PMC LH2 tank was thought to be initiated by microcracking of the polymer matrix in the composite inner skin of the tank structure reference 2. The microcracking of the composite resulted from the CTE mismatch in the carbon fiber and the polymer matrix in combination with a large difference between the composite fabrication temperature and the temperature of liquid hydrogen. The microcracks provided a path for the pressurized hydrogen to leak or permeate through the wall and enter the honeycomb core. When heated, the matrix cracks closed, the liquid evaporated and the resulting gases having no place to escape caused a rise in pressure and eventual delamination of the core from the inner composite skin. In order to solve the permeability problem, NASA LaRC and MSFC worked together to develop and investigate polymer films that will act as a barrier to the permeation of LH2 through the IM7/977-2 composite laminate, reference 2. Even though two stand alone films showed promise, the permeability results showed that the films were not effective barriers when incorporated into the composite. However, more recent work, reference 3, on the fabrication of graphite/epoxy (IM7/9772) PMC composite with barrier films to reduce the permeability of composites subjected to thermal cycling and low velocity impacts has shown promise for barrier films. In this research a durable barrier layer material was placed as the middle ply within the composite. The results of this research suggest that the addition of an embedded barrier layer can increase a graphite/epoxy composite's resistance to thermal stresses and low-velocity impacts, by allowing the composites to remain leak free after thermal cycling and increasing the amount of impact the composite can withstand before leaking.

## **c. Low Permeability Resins**

Another approach to address the permeability issue is to use polymer-silicate nanocomposites. This approach has been examined at NASA Glenn Research Center, reference 4. A T650-35 fiber, eight-harness satin-weave, eight-ply carbon fabric was used to reinforce a thermoplastic (BPADE-BAPP) polyimide/silicate nanocomposite matrix, with a fiber content of 60 wt%. The matrix had 2 wt% bentonite clay nanoparticles. The silicate layers were believed to be dispersed on the nanometer level. Helium permeability measurements show that the gas permeability was

reduced by 70 percent, compared with that of the neat resin matrix composite, as shown in figure 1. Hydrogen permeability results were not reported. The reduction in permeability is believed to be due to an alignment of the silicate layers by the carbon fibers, thus lengthening the gas diffusion path. This composite shows an increase in stiffness but no increase in flexural or interlaminar shear strength with respect to the neat resin.

In addition, other research with carbon fiber nanoclay particle-reinforced polymer matrix composites for cryogenic applications has been reported by Timmerman et al., reference 5. Layered inorganic clays were incorporated in the matrices of carbon fiber/epoxy composites to determine their effect on the response of these materials to cryogenic cycling. No significant change in laminate mechanical properties was observed in any of the nanoclay-modified systems studied. It was found that the laminates containing nanoclay reinforcement in the proper concentration exhibited considerably less microcracking than the unmodified or macroreinforced materials as a response to cryogenic cycling. Nanoclay or other particulate-enhanced toughened epoxies using conventional continuous fiber reinforcement may potentially provide the necessary micro crack resistance and permeation resistance to hydrogen.

There have been efforts by different companies to develop microcrack resistant and low permeability composites for cryogenic tanks, reference 6. For example, Wilson Composites has worked for more than 12 years under contracts for the U.S. Air Force on new material approaches. The company has developed composite tankage for Air Force space programs, e.g., the FALCON (Force Application and Launch from the Continental U.S.) launch vehicle. To make liner-less tanks, the company worked with a variety of carbon fibers in combination with toughened epoxies and cyanate esters supplied by Advanced Composites Group (ACG, Tulsa, Okla.), Bryce Technologies Inc. (Morgan Hill, Calif.), YLA Advanced Composite Materials (Benicia, Calif.), and A.T.A.R.D. (Lincoln, Neb.), among others. The company has developed a microcrack-resistant fiber/resin system (pat. pend.) for towpreg (prepregged carbon tow) that is superior for cryogenic applications, based on coupon test results. Several demonstration liner-less tanks, as large as 1.8m/6 ft long by 1.2m/4 ft in diameter, have been filament wound and tested. Wall thickness is typically 2 mm to 2.6 mm (0.08 inch to 0.1 inch) for tanks containing fuels at 6.9 bar to 10.3 bar (100 psi to 150 psi).

XCOR Aerospace (Mojave, Calif.) has taken a very different approach to cryogenic materials. The company recently signed a contract for development of a demonstration composite LOX tank, under NASA's Exploration Systems Research and Technology program. The company's material system is Teflon thermoplastic fluorocarbon resin supplied by DuPont (Wilmington, Del.), teamed with S-2 Glass from AGY (Aiken, S.C.). Various grades of fluorocarbon are currently being assessed. The fluorocarbon system is highly resistant to combustion in an oxygen environment and will not microcrack, because of its low CTE and high strain capability. The fluorocarbon resin has 20 percent strain-to-failure at cryogenic temperature due to the flexibility of thermoplastics at low temperature. So far, successful coupon-scale tests have been conducted with liquid nitrogen at -195°C/-320°F including measurement of CTE, tensile strength (at both ambient and cryogenic temperature), and porosity and microcracking, with and without temperature cycling, reference 6.

NASA with HyPerComp Engineering (Brigham City, Utah) and Mississippi State University is investigating much smaller high-pressure tanks made from new materials. HyPerComp has screened various fiber/resin combinations for high-performance, space-worthy pressure vessels.

Carbon fibers from Toray Carbon Fibers America Inc. (Flower Mound, Texas), and Grafil Inc. (Sacramento, Calif.) and other fiber types, including Zylon fiber from Toyobo (Osaka, Japan) were tried. Fibers were combined with an array of variously modified epoxy resin systems, in both prepreg form as well as wet winding processes, and some polyurethanes were also investigated to optimize key parameters for cryogenic performance, namely, the matrix's elongation and elasticity to discourage micro-cracking and controlling fiber sizing to improve resin/fiber adhesion. The tests have revealed that a wet-winding fiber/resin combination of Toray T1000 carbon fiber and a proprietary epoxy resin system (HEI 535) performs well above expectations and did not deteriorate at cryogenic temperatures. However, data on the system is generally not available in the open literature.

#### d. Microcracking-Modeling

One of the key technical challenges in developing linerless tanks is to design the composites to resist microcracks that can lead to leakage of hydrogen. Such a development calls for R&D on microcrack resistant resins and appropriate testing as shown in Figure 23. Microcrack modeling would help in the developmental effort.

**LH<sub>2</sub>-Impermeable, Microcrack-Resistant Resins/Composites**  
**--Recommendation--**  
**Microcrack/Permeability Testing Program:**

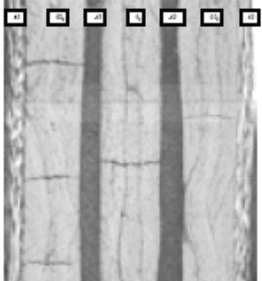
**Materials and Processes:**

1. 3-4 Current Resin/Fiber Composites: e.g., 977-2/IM-7, PEEK/IM-7, HEI 535/IM-7, 3900-2/T-800
2. New Low Permeability Resins/Composites
3. Interleafed Barrier Films: e.g., Al/Mylar, etc.
4. Automated Tow or Tape Placement
5. Ultrasonic Consolidation where Applicable.

**Testing:**

1. Thermal Cycles from RT to -423°F; NDE Before and After Cycling.
2. Permeability testing – Loaded & Unloaded
3. Microstructural Characterization
4. Data Evaluation via Current Theories

**X-33 Inner face Sheet**



**IM-7/PIXA laminate from TP-ATP and placement-grade tape**

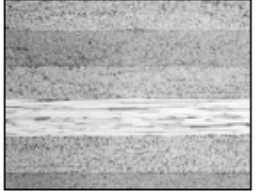


Figure 23 – Microcracking and Permeability Testing

There are ongoing research efforts to improve the design and fabrication capabilities of linerless composite tanks through micromechanical modeling by Composite Technology Development, Inc. (CTD), funded by Air Force and NASA. References 7 and 8. CTD has developed and implemented an Integrated Systematic Approach (ISA) for developing novel microcrack resistant

materials to meet the performance targets of linerless composite tanks under Air Force funding. Use of an ISA requires the concurrent development of tank specifications, engineering and micromechanics models, novel resins and purpose-designed composite materials and innovative processing techniques. ISA essentially relies on an iterative effort to improve both material properties and structural design, with micromechanics bridging the gap between material science and structural design. Transverse tensile strength provides the first level of information of material performance against microcrack resistance. Due to its simplicity, transverse tensile strength test is suitable for screening the candidate materials based on laminates fabricated identically with laminate characteristics typical of a filament wound tank construction. Results of transverse tensile strength of several toughened epoxy materials developed at CTD, reference 7, are compared to other materials typically used in the aerospace industry. A more rigorous approach to the material selection process is the use of microcracking fracture toughness tests that provide information on microcrack accumulation under tensile load. The microcracking fracture toughness test procedure that has been developed at CTD and how these tests are being used to characterize the toughened matrix materials for their application in linerless composite tanks is reported in reference 7. Preliminary results have found that the rate of growth of microcracks in a cross-ply laminate subjected to a tensile load can be different for matrix systems even if they have similar transverse tensile strength. The experimentally determined microcracking fracture toughness is an intrinsic material parameter and can predict microcrack accumulation under a variety of loading conditions and laminate configuration without the need for repeating the experiments for different cases. This provides a significant advantage over transverse tensile strength that is dependent on laminate thickness and architecture and hence necessitates repeated material tests for different laminate configuration.

In a subsequent paper, reference 8, Mallick describes how micromechanics-based analysis can be used to define critical material-performance parameters that drive the development of new toughened matrices, and predict micro crack formation and permeability in composite laminates under biaxial load. Key concepts were presented that help optimize the structural design of linerless composite tanks. The paper presents the progress to date in designing and fabricating linerless composite tanks using a newly developed, CTD 7.1 toughened and micro crack-resistant epoxy resin with Toray T700-SC 12K carbon fiber.

In another study Kevin Ryan et al, reference 9, present an approach for characterizing the accumulation of micro cracks in linerless composite tank materials under cyclic mechanical loading associated with multiple fill-and-drain pressure cycles. The model assumes that the rate of microcrack-damage accumulation is related to the microcracking fracture toughness of the material through a modified Paris-law formulation. A key artifact of this model is that microcrack-damage accumulation under cyclic load can be predicted from only two material constants. This damage accumulation model is validated through a series of coupon tests, and an illustrative example is presented to demonstrate how the model can be used to predict the micro cracking performance of a linerless composite tank subjected to fatigue cycles.

Choi Sukjoo, reference 10, have developed a micromechanics method to investigate microcrack propagation in a liquid hydrogen composite tank at cryogenic temperature. The laminate properties estimated by the micromechanics method were compared with empirical solutions using constituent properties. The micro stresses in the fiber and matrix phases based on boundary conditions in laminate level were calculated to predict the formation of microcracks in the matrix. The method is applied to an actual liquid hydrogen storage system. The analysis predicts micro

stresses in the matrix phase are large enough to cause microcracks in the composite. Stress singularity of a transverse crack normal to a ply-interface was investigated to predict the fracture behavior at cryogenic conditions using analytical and finite element analysis. Finite element analysis was performed to predict the fracture toughness of a laminated beam subjected to fracture loads measured by four-point bending tests at room and cryogenic temperatures. As results, the fracture load at cryogenic temperature was significantly lower than that at room temperature. However, when thermal stresses are taken into consideration the difference of the fracture toughness becomes insignificant. These results suggest that fracture toughness is a characteristic property, independent of temperature changes.

### e. Recommended R&D Programs

Because composites offer significant potential to reduce weight of critical components of the Constellation Program, it is important that these materials be optimized for the expected service environments of launch, in orbit, on the Lunar Surface, and in the Mars environment. Because of the extreme low temperatures that composites will experience in these environments, an aggressive R&D effort should be undertaken to investigate and develop, if necessary, new resins and toughening approaches to yield composite with high fracture toughness at cryogenic temperature. The toughening mechanisms should be validated for cryogenic applications. Also resin chemistries can be modified to improve radiation shielding and to reduce permeability of H<sub>2</sub> or other propellants. Processing studies should be done in parallel to insure ease of fabrication for large complex geometry parts. Other elements of this recommendation are shown in Figure 24.





	<b>Low Permeability Microcrack Resistant Composites</b>	
<b><u>Recommended R&amp;D</u></b>		
<ul style="list-style-type: none"><li>◆ <b>Fund resin screening/development R&amp;D to optimize resins for fabrication of high quality space composite structural elements</b><ul style="list-style-type: none"><li>– Resin formulation for reduced H<sub>2</sub> permeability - toughened epoxies, thermoplastics, nano -additions, degree of crystallinity , barrier films etc.</li><li>– Explore resin toughening mechanisms to establish if current toughening approaches are optimum for cryotank applications</li><li>– Develop cryo -tough resins to reduce microcracking through new toughening approaches and/or self healing resin formulations</li><li>– Develop composite processing technology to fabricate composite laminates with low residual stress from these new cryo -optimized resin formulations</li><li>– Explore optimizing adhesives chemistries for extreme temperature environments</li></ul></li><li>◆ <b>Fabricate and test composite laminates and structural subelements under simulated space use conditions including combined loading and thermal cycling</b></li><li>◆ <b>Perform microstructural /property correlation to support micromechanics modeling</b></li></ul>		

Figure 24 – Recommended R&D for Low Permeable and Microcrack Resistant Composites

## f. References

1. Mittal SK et al, "Review of Current State of the Art and Key Design Issues with Potential Solutions for Liquid Hydrogen Cryogenic Storage Tank Structures for Aircraft Applications", NASA TM-2006-21346
2. Grimsley B.W. et al, "Hybrid Composites for LH2 Fuel Tank Structure," NASA Document ID 20040086019, 2001
3. Amelia Ann Case, "Permeability of Hybrid Composites subjected to Extreme Thermal Cycling and Low-Velocity Impacts," MS Thesis, Georgia Institute of Technology, November 2004, [http://etd.gatech.edu/theses/available/etd-11222004-103613/unrestricted/case\\_amelia\\_a\\_200412\\_mast.pdf](http://etd.gatech.edu/theses/available/etd-11222004-103613/unrestricted/case_amelia_a_200412_mast.pdf)
4. Miller Sandy et al, "Clay Nanocomposite Aerogel Sandwich Structures for Cryotanks," NASA Document ID 20060005182, January 2006
5. Timmerman John F., et al, "Cryogenic Microcracking of Nanoclay Reinforced Polymeric Composite Materials," SAMPE 2002, Long Beach CA, May 2002
6. Sara Black, "An Update on Composite Tank for Cryogenes," High Performance Composites, November 2005, <http://compositesworld.com/hpc/issues/2005/November/1069>
7. Kaushik Mallick et al, "Ultralinerless Composite Tanks for In-Space Applications," presented at the AIAA Conference, San Diego, Sep 2004, <http://www.ctd-materials.com/papers/menu.php>
8. Kaushik Mallick et al, "An Integrated Systematic Approach to Linerless Composite Tank Development," presented at the 46<sup>th</sup> AIAA Structures, Structural dynamics and Materials Conference, April 2005, <http://www.ctd-materials.com/papers/menu.php>
9. Kevin Ryan et al, "Prediction of Pressure Cycle Induced Microcrack Damage in Linerless Composite Tanks," AFRL-ML-WP-TP-2006-435, March 2006
10. Choi Sukjoo et al, "Micromechanics, Fracture Mechanics and Gas Permeability of Composite Laminates for Cryogenic Storage Systems, NASA Document ID 200550220621, 2005

## E.2 Non-Autoclave Curing Composites for Large Tanks



### Non-Autoclave Curing Composites for Large Diameter (33ft.) Cryotanks

**What is the Issue:**  
Autoclaves not large enough to handle Ares V cryotanks

- Ares I Upper Stage (LH&LO) – 18 ft. dia. & 63 ft. long
- Ares V Earth Departure Stage (LH) – 27.5 ft. dia. & 41 ft. long
- Ares V Core Stage (LH) – 33 ft. dia. & 129 ft. long

**What is Needed:**

- (1) Resins and fabrication technology to manufacture high quality composite tank 18 to 33 ft. in diameter & up to 129 ft. in length
- (2) Building block experimental test program to develop resins and fabrication technologies for large diameter tank structures



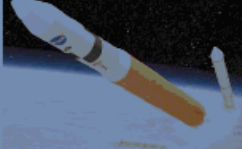
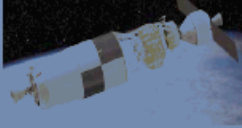
**Payoff:**

- 25 to 30% weight savings - composite tanks versus metal tanks

**State-of-the-Art**

Fiber placement with ultrasonic compaction for 10-ft cryotank half

Fiction stir welding vertical weld tool for Shuttle ET 27.6 ft. dia. & 154 ft. long (multiple section)



**Figure 25 – Non-autoclave Curing Composites for Large Diameter Cryotanks**

### a. Issues, Needs, Payoff

A non-autoclave fabrication process is needed for the manufacture of very large diameter cryotanks for the Ares V launch vehicle, Figure 25. The world's largest autoclave by volume, 30' diameter x 75' long, was built by Vought to fabricate composite fuselage sections for the new Boeing 787 Dreamliner. It would not be adequate to handle Ares V cryotanks if built in full-diameter sections. The Ares V Core Stage LH tank measures 33' in diameter and 129' long. Even an autoclave cure for the Ares V Earth Departure Stage LH tank, 27.5' diameter by 41' long, would be questionable. The Ares I Upper Stage LH and LO tanks, 18' diameter by 63" long, could be fabricated by current autoclave technology.

Ultra-low permeability, microcrack-resistant, polymer matrices and their composites optimized for cryogenic tank applications were discussed in the last Section (Figures 26, 27 of the oral presentation). The following programs are needed: (1) an out-of-autoclave fabrication technology development to manufacture large, high quality composite cryotanks and (2) a building block experimental test program involving fabrication of a series of composite structures from flat plates to a subscale tank. AS&M calculates a 25 to 30 percent weight savings for composite tanks versus metal tanks.



## b. Background on Non-Autoclave Curing

Figure 25 shows a picture of a friction stir welding vertical weld tool fabricating a section of the External Tank (ET). The ET is 27.6' in diameter and 154' long and comprised of multiple sections welded together. It is probable that an Ares V Core Stage LH2 tank would be fabricated by a similar process.

The current and most popular automated fabrication process using autoclave curing is automated fiber or tape placement. Either filament winding, tape, or tow placement machines are employed to place uncured thermoset-coated fiber, tow, or tape onto a shaped tool followed by autoclave curing on the tool. The compaction pressure employed during placement is insufficient to achieve full consolidation; the most significant advantage of autoclave curing is the 0.69-1.38 MPa (100-200 psi) compaction pressure applied during cure of the thermoset (usually epoxy for high performance composites). These compaction pressures lead to the low porosity microstructure required for high performance. The compaction pressures for a number of autoclave and non-autoclave processes are shown in Figure 26, reference 1. The thermoset fiber placement/autoclave process discussed above is shown third from the top in the bar chart. A number of vacuum bag processes are popular because they usually are very economical and easy to use. Compaction pressures for four processes are shown in the bar chart. Most of these processes are employed for low performance composites.

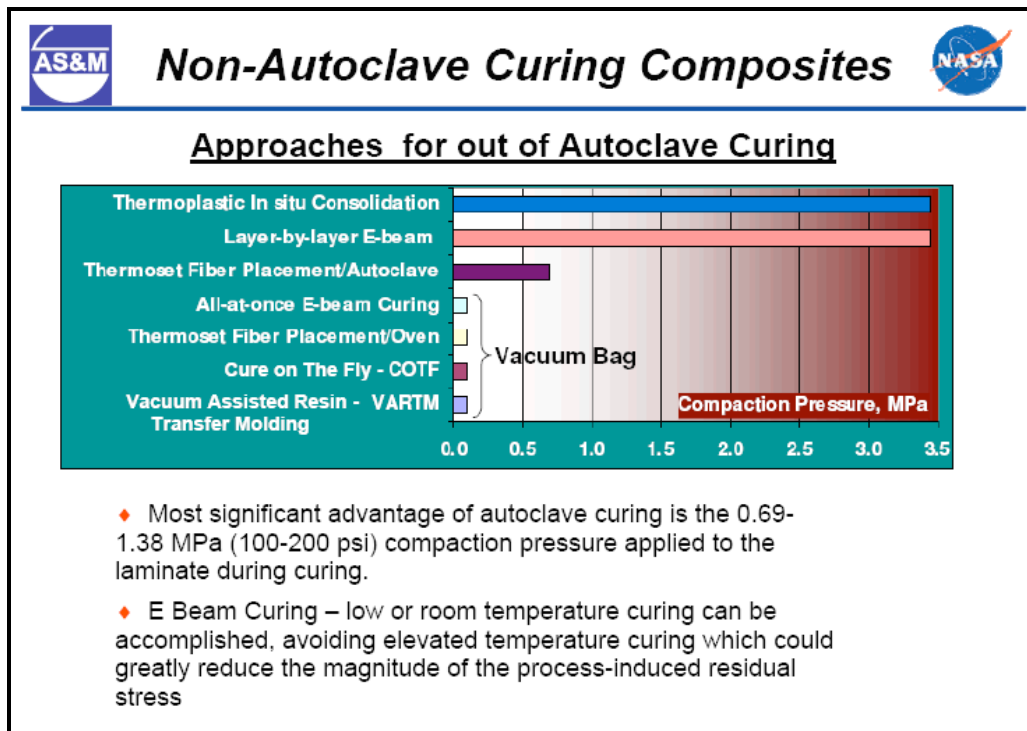


Figure 26 – Non-autoclave Curing Composite Processes

The two key non-autoclave curing processes for high performance epoxy thermosets are (1) automated fiber placement with ultrasonic compaction and vacuum bag curing and (2) automated fiber/tow/tape placement with E-beam curing. For the former process, Figure 25 shows a 10.5'-

diameter half tank being fabricated at ATK, Iuka, MS, over honeycomb vented core on a Titan wet filament would mandrel using the Foster-Miller Ultrasonic Ply Compaction (UTL) head.

The more embryonic layer-by-layer E-beam thermoset cure process uses a high normal force to compact the microstructure as an integral step in the placing process, as shown in the bar chart in Figure 26. This cure-on-the-fly technique can be done at a relatively low temperature which greatly reduces the magnitude of the process-induced residual stresses.

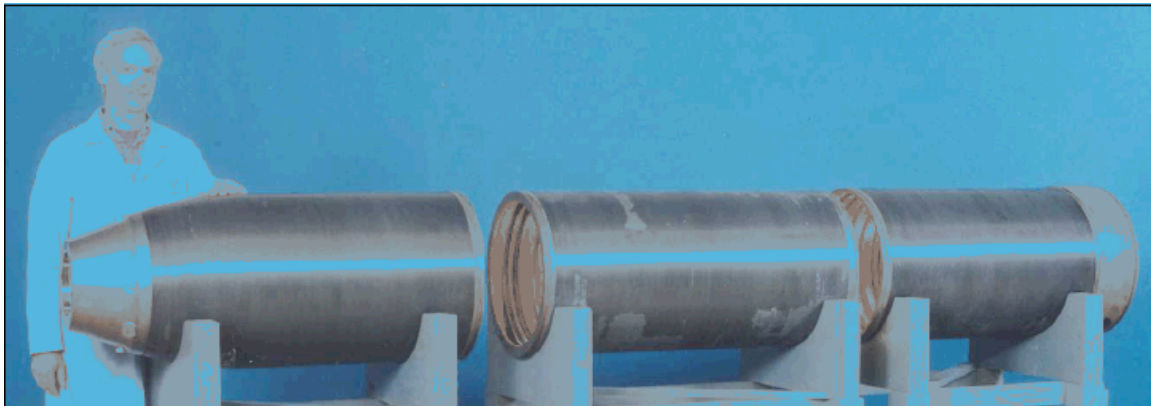
One of the most promising non-autoclave processes involves thermoplastic in-situ consolidation with a heated placement head. Again, as seen in the bar chart of Figure 26, a high normal force is employed by the heated head during placement which achieves the required low porosity microstructure. As with most of the automated non-autoclave techniques, innovative conformable compactors are required for placing on complex shapes. Such compactors have been successfully proven out and will be described below.

### **c. State of the Art: In-Situ Fiber Placement of Thermoplastic Tow and Tape**

Thermoplastics composites are effective substitutes for autoclave-consolidated thermoset composites in aerospace and defense applications to take advantage of beneficial resin properties such as thermal stability, toughness, infinite out-time and capital and fabrication cost reductions afforded by non-autoclave consolidation, references 2-5.

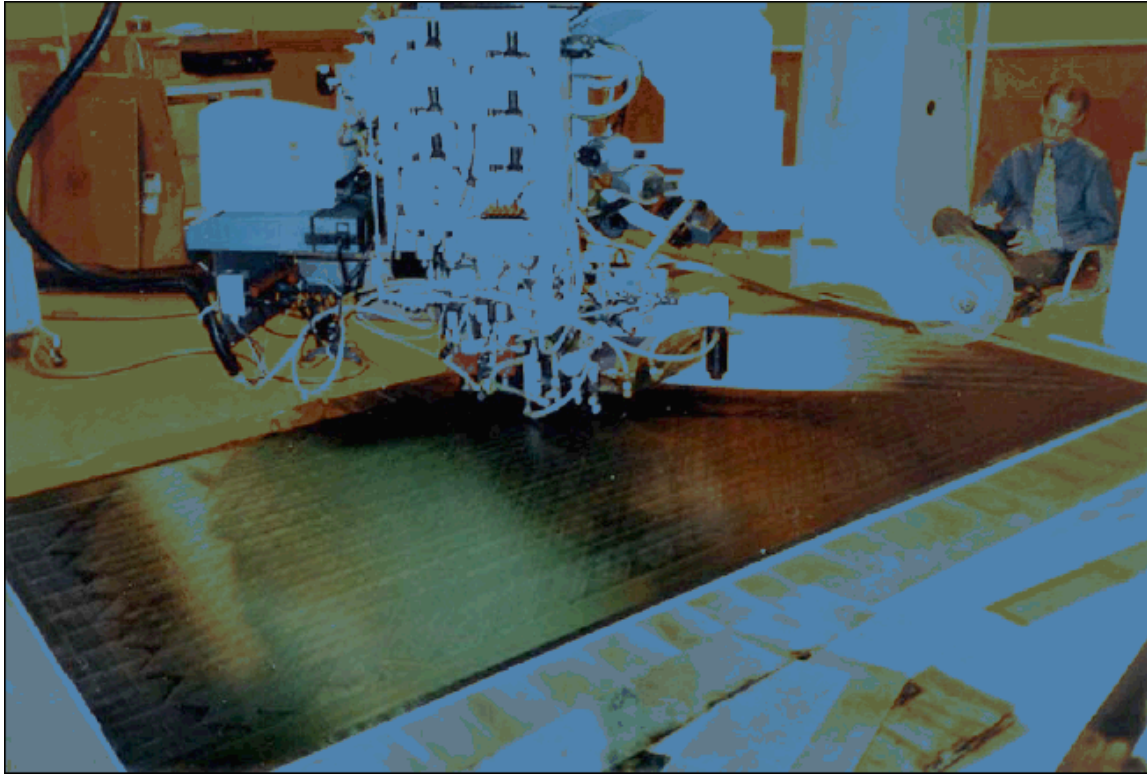
Out-of-autoclave cost savings using thermoplastic in-situ consolidation are proportional to the size of the laminate fabricated, since the largest thermoset matrix composite laminates and tools require the largest autoclaves. Thus, thermoplastic process development programs are usually linked to the fabrication of large aircraft skins or space vehicle tanks. The desire for out-of-autoclave fabrication of high performance composites continues to fuel thermoplastic composite development. Thermoplastic in-situ fabrication is the most mature of the out-of-autoclave fabrication processes.

In the 1990's, the composites industry replaced hand lay-up with automated fiber placement and tape laying as the preferred routes to prepare thermoset parts for autoclave consolidation. At that time, Accudyne Systems was fabricating high quality underwater vehicle pressure hulls from IM-7/PEEK thermoplastic using in-situ consolidation technology, as shown in Figure 27.



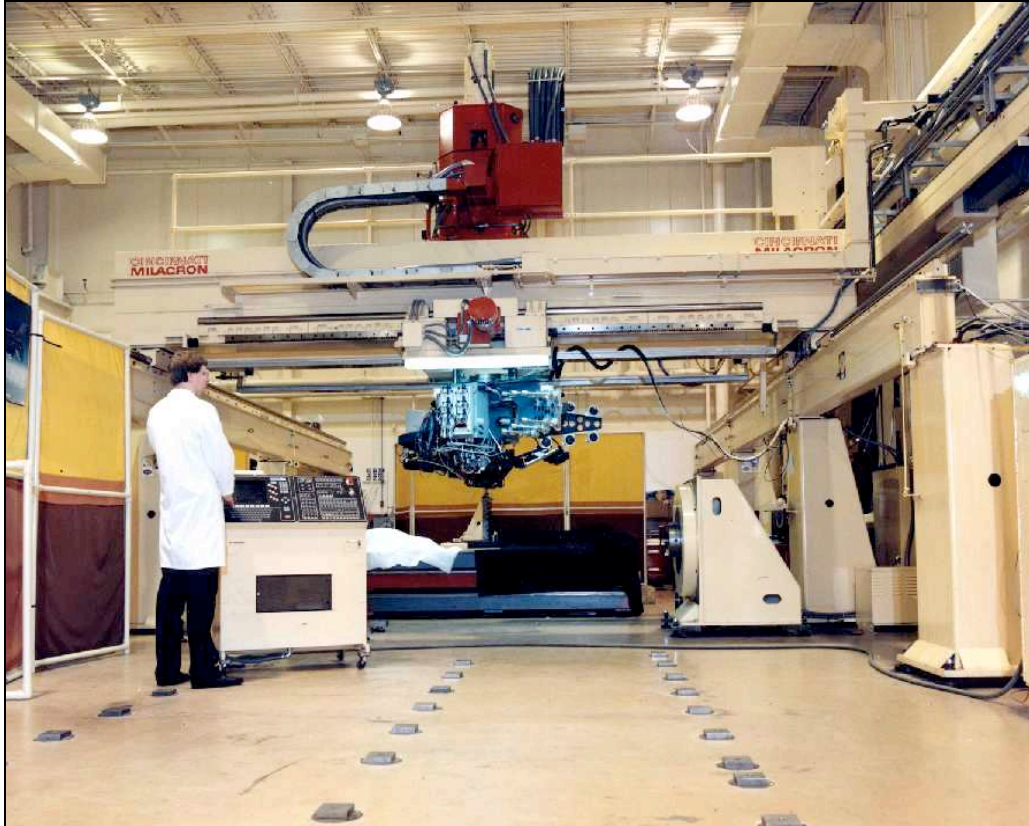
**Figure 27 – Accudyne fabricated a number of IM-7/PEEK underwater vehicle pressure hulls for the US military using the in-situ consolidation process.**

To compete with thermoset ATP technology, Accudyne extended their process by developing the placement head shown in Figure 28, along with the associated controls.



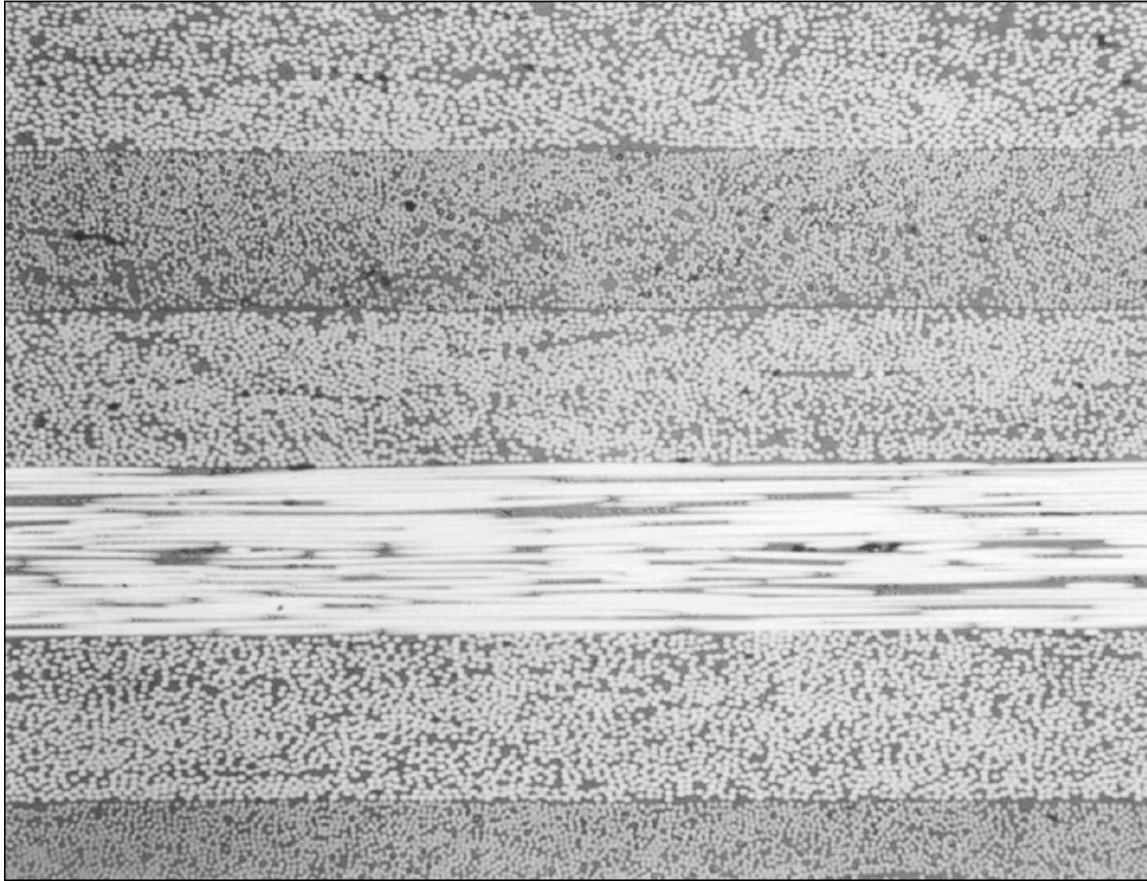
**Figure 28 – In-situ deposition tape-laying head consolidating 75mm APC-2/AS-4 tape on a laminate at speeds up to 5mpm (20fpm).**

The heated deposition head, capable of gentle contour, operated on a Cincinnati Machine gantry tape placement machine modified to coordinate the polymer process with course deposition, as shown in Figure 29. The in-situ consolidation process fabricated aircraft quality composite structure from dry, boardy tape or tow possessing infinite out-time.



**Figure 29 – Flat laminates fabricated by thermoplastic tow placement using a 12-tow head to place a 3-inch (76mm) wide band.**

During the HSR Program, NASA Langley Research Center assigned a team to demonstrate the in-situ process by fabricating flat laminates and skin stringer and honeycomb built-up structure to meet aircraft thickness, weight, and mechanical property specifications. PEEK, PIXA, PIXA-M, and PETI-5 placement-grade tows and tapes were developed and laminates were fabricated and tested. Laminate quality is exemplified by the excellent IM-7/PIXA laminate photomicrograph in Figure 30, showing well-consolidated resin interfaces, few voids, no microcracking, a uniform fiber/resin distribution, and no ply waviness.



**Figure 30 – Photomicrograph of high quality IM-7/PIXA laminate from TP-ATP and placement-grade tape.**

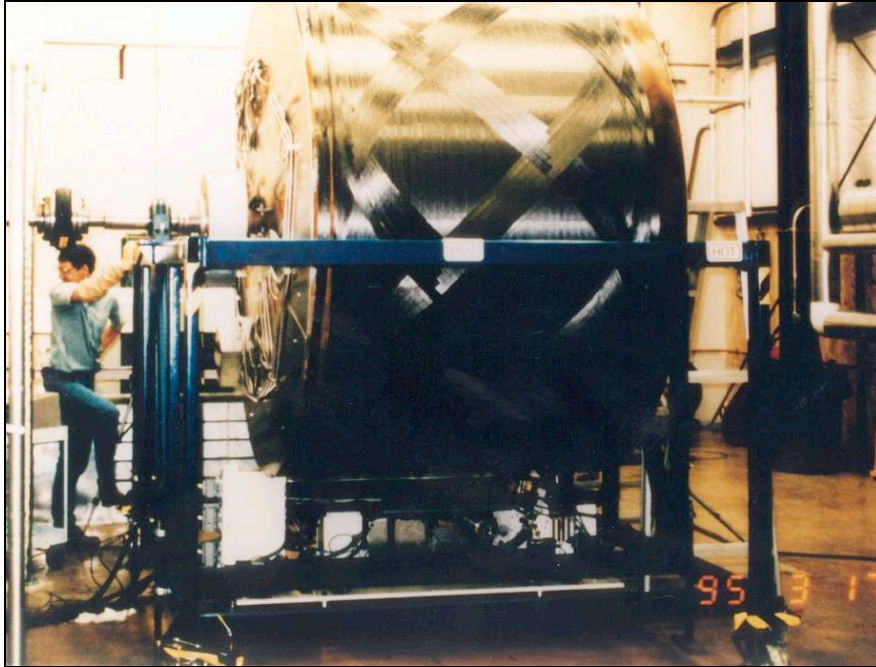
Accudyne also manufactured large structure using the in-situ consolidation process. A 96-inch diameter, 800-pound fan containment case was made in 96 hours from IM-7/PEKK. The fabrication of the case is shown in Figure 31 and the finished case is in Figure 32. Accudyne Systems has continued to develop its thermoplastic head and process. In particular, the head has been used to fabricate complex structure with slopes, ramps, double slopes, joggles, and pad-ups.

Properties have increased as follows with AS-4/PEEK laminates:

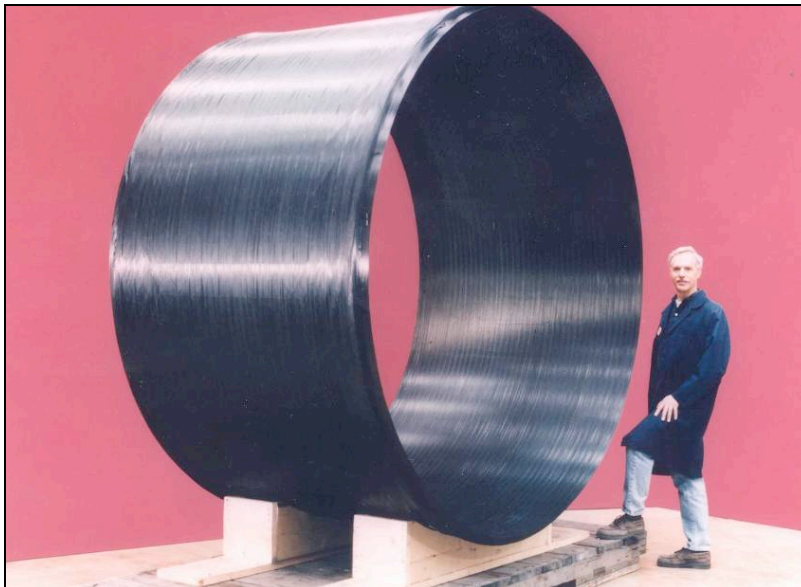
73 Ksi (500 MPa) quasi compression strength

42 Ksi (290 MPa) quasi OHC

21.8 Ksi (150 MPa) IPSS.



**Figure 31 – Out-of-autoclave fabrication of an IM-7/PEKK quasi-isotropic fan containment case. The case weighed 800 pounds, was 96" in diameter, and was finished in 96 hours.**

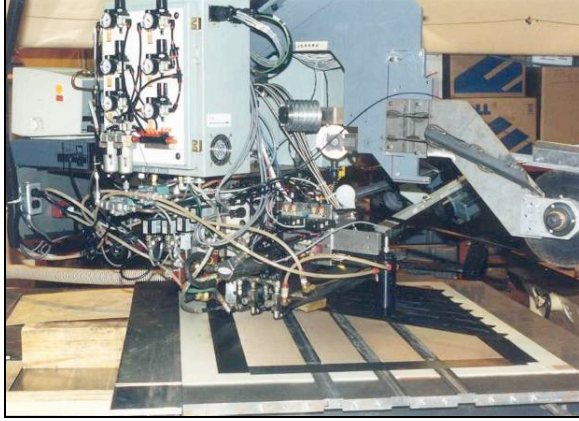


**Figure 32 – The fan containment case was fabricated out-of-the autoclave from IM-7/PEEK.**

#### **d. Built-Up Structure: Stringer Stiffened Thermoplastic Skin Fabrication**

Importantly, built-up structure also has been fabricated. Skin-stringer laminates were manufactured by building an IML tool embedded with preconsolidated thermoplastic stringers (or thermoset stringers coated with a thermoplastic film layer) and then tape placing over them using the heated head in-situ consolidation process to produce a stringer flange-skin weld. This process is known as primary ( $1^\circ$ ) bonding, as shown in Figure 33, and is the most efficient since it is a non-autoclave process. Secondary ( $2^\circ$ ) bonding of preconsolidated laminates and stringers to a pre-finished skin in the autoclave also can be employed as well as co-bonding where an autoclave is used to consolidate the stringers while at the same time bonding them to a pre-finished skin

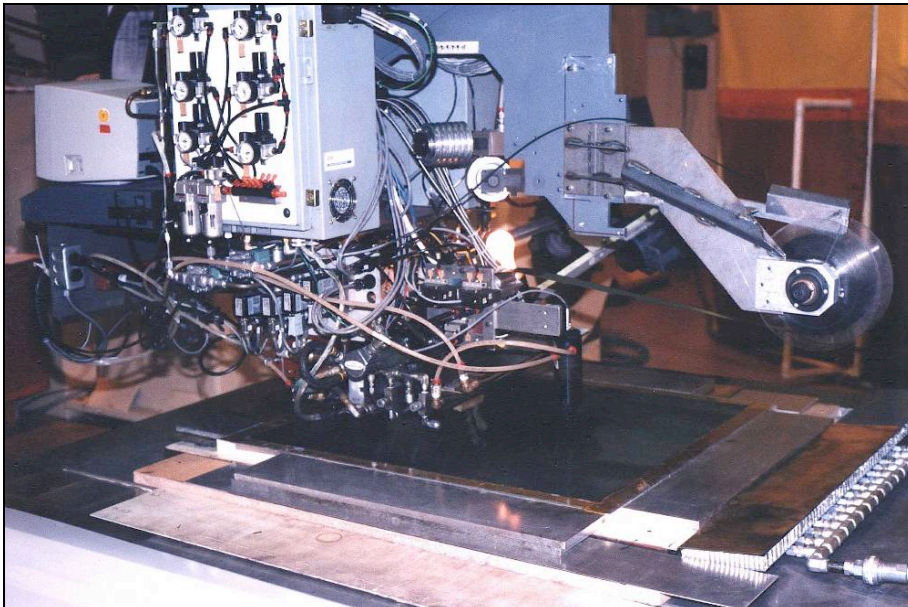
laminate. ATP skin stringer laminates were made by 1°, 2°, and co-bonding. The 1° bonding process is depicted in Figure 33 where the first few courses are being placed and in-situ welded directly over three blade stringers. Figure 33 shows the finished panel. PEEK or PIXA-M thermoplastic film matching the skin resin was co-cured to the blade surface prior to placement to aid in the weld process.



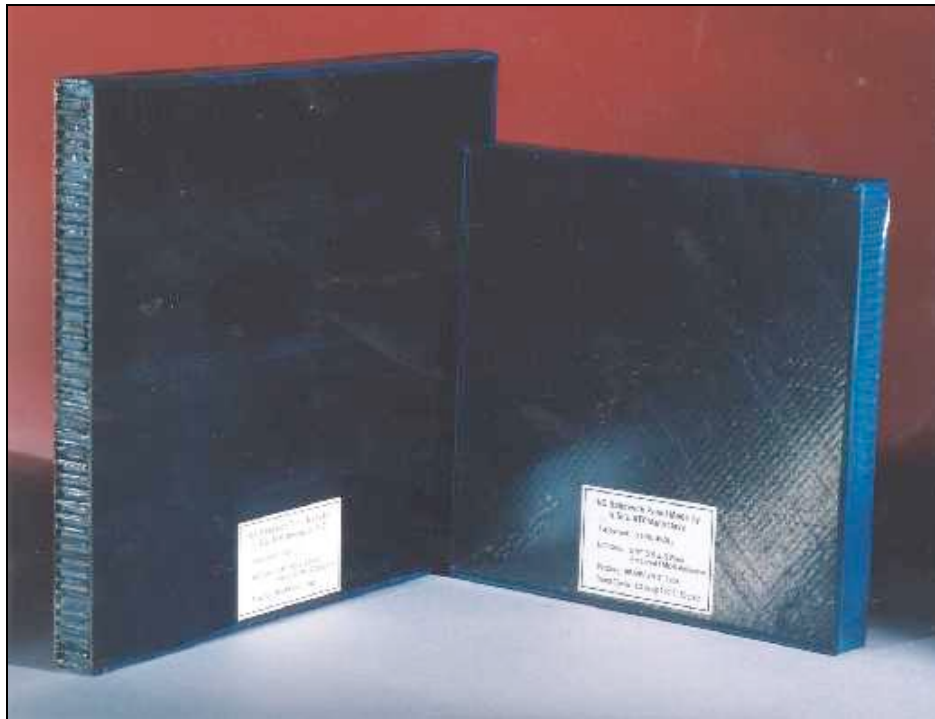
**Figure 33 – A  $[\pm 45^\circ/0^\circ_2/90^\circ/0^\circ_2/\pm 45^\circ]$ s skin stringer laminate fabricated entirely out-of-the-autoclave using primary bonding. Many IM-7/PEEK, PIXA-M, and PETI-5 panels have been made by this process.**

#### **e. Built-Up Structure: PMC/Honeycomb Panel Fabrication**

Thermoplastic in-situ consolidation was also used to fabricate 1° and 2° bonded honeycomb panels. In 1° bonding, facesheets were tape placed directly over titanium core precoated with roller-coated BRX-5® paste adhesive, FMX-5® film adhesive, and PEEK or PIXA-M film. Figure 10 shows the heated head placing a laminate directly over titanium core. Run-on and run-off tooling surrounds the core so it cannot be seen in the photo. In 2° bonding, in-situ consolidated facesheets were bonded to core with BRX-5® under light autoclave pressure.



**Figure 34 – Primary bonding using thermoplastic in situ consolidation to place 76mm (3-in) tape on honeycomb core precoated with BRx-5 and FMx-5 adhesives.**



**Figure 35 – A portion of a completed PMC-Honeycomb laminate fabricated with in-situ consolidation.**

Table 1 lists the excellent mechanical properties measured on a variety of honeycomb core-stiffened ATP laminates. Almost all properties from primary and secondary bonded core-stiffened laminates exceed that of the traditional wet-thermoset autoclave-processed co-cured panels. Of particular interest is the edgewise compression strength, which, at 421 to 486 MPa (61.0 to 70.5 ksi), far exceeds that from co-cured wet panels, 306 MPa (43.8 ksi).

		Primary Bonded IM-7/PIXA-M	Secondary Bonded IM-7/PIXA-M	Co-cure Wet IM-7/PETI-5	Secondary Bonded dry IM-7/PETI-5
Flatwise tension	MPa	11.6	7.8	12.4	
Edgewise Compression	MPa	477	421	306	486
1-inch Notched Compression	MPa	179	187	161	
CAI	24.8 N-m impact MPa	332			
CAI	8.5 N-m impact MPa		347	332	

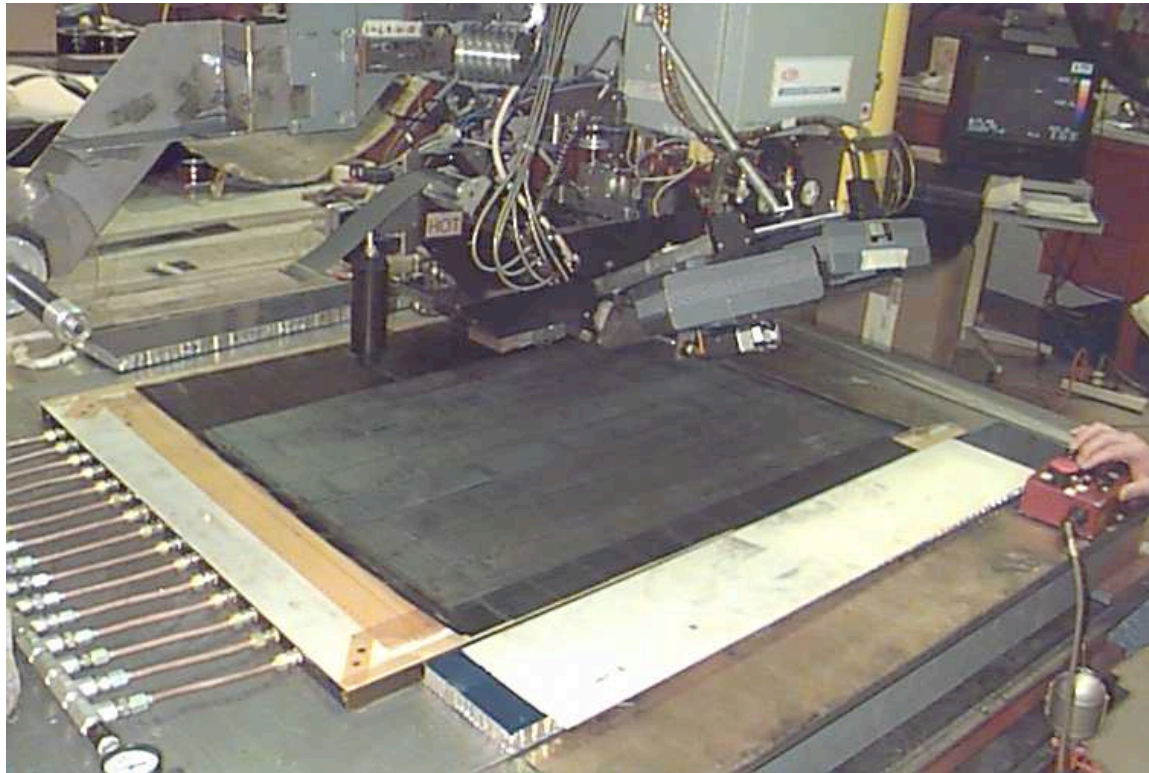
**Table 1. Mechanical properties of honeycomb core-stiffened panels**

#### **f. Built-Up Structure: TiGr (Titanium-Graphite) Flat and Honeycomb Panel Fabrication**

Titanium-graphite laminate fabrication is considered for use on wing and fuselage skins in order to raise the specific strength and specific stiffness of laminates. Titanium and composite plies are alternatively interleaved to form a composite/metal hybrid laminate. In the case of thermoplastic fiber placement, 76mm (3-in) wide titanium foil was pre-coated with PEEK polymer film and cut into 91cm (36-in) long strips. These strips were then heat-placed through the same depo-



sition head used for placing 76mm (3-in) PEEK tape. A number of TiGr laminates were fabricated in this manner, Figure 36.



**Figure 36 – The in situ heated 76mm (3-in) deposition head used to place Ti foils and IM-6/PEEK tape into a TiGr laminate with in-situ consolidation.**

Figure 37 shows samples cut from two TiGr honeycomb flat laminates. The laminates were made by heat placing the bottom TiGr laminate, adding core, and then placing the top TiGr laminate on the inverted part to complete the panel.



**Figure 37 – TiGr honeycomb laminates made by interleaving titanium and IM-6/PEEK plies using the primary bonded honeycomb process.**

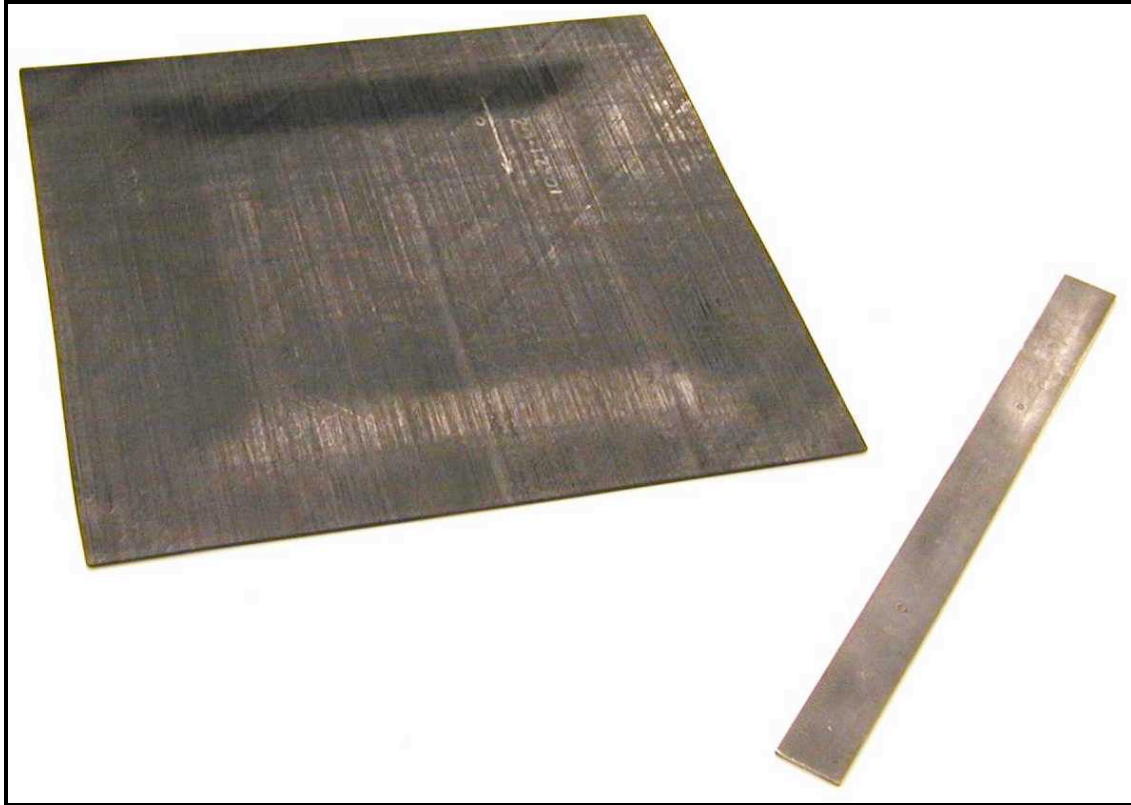
A portion of the final autoclaved laminate was tested for longitudinal and transverse un-notched compression; the results are in Table 2. They compare favorably with strengths measured from hand laid-up TiGr honeycomb sandwich panels that used 610mm (24-in) wide foil and had no seams. As expected, transverse values for the ATP laminate were lower due to the presence of seams in the foil.

	Longitudinal EWC, MPa (KSI)	Longitudinal Strain ( $\mu$ strain)	Transverse EWC, MPa (KSI)	Transverse Strain ( $\mu$ strain)
Laminate 97-6-3-1	896 (130)	8700	427 (62)	6500

**Table 2. Un-notched Compression of TiGr ATP Autoclave 1° Bond Laminate**

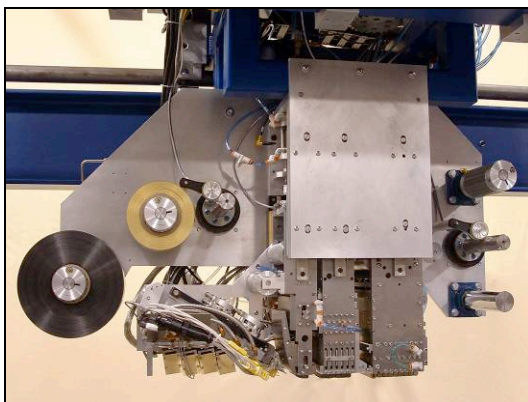
**g. Placing Contoured Structure using In-Situ Consolidation**

Actual aerospace structure has been contoured and programs have been completed demonstrating heated and chilled conformable compaction for the deposition head. These compactors allowed process heating and resin re-solidification while accommodating a 6 mm tall ply detail over a 10:1 slope. A portion of an APC-2/AS-4 joggle laminate is shown in Figure 38.



**Figure 38 – An APC-2 joggle laminate is successfully placed using heated and chilled conformable compactors on the head.**

The ensuing contoured deposition head, shown in Figures 39 and 40, features heated line and area conformable compactors to establish intimate contact and reptation healing between the pre-consolidated laminate and the tape being placed, followed by chilled line and area conformable compactors to consolidate the laminate.




**Figure 39 – The contoured deposition head can place twelve 6.35 mm wide tows or one 75 mm wide tape by changing feeders.**




**Figure 40 – Accudyne Systems installed a heated thermoplastic deposition head at NASA-LaRC. The head consolidates thermoplastic tape into a laminate using Accudyne’s in- situ consolidation process. The head’s three conformable compactors allow fabrication of laminates with complex curvature.**

## h. Recommended Program

A phased development program utilizing a building block approach is recommended. This program would bring thermoplastic process and equipment technology to manufacture a full-scale tank. The phases of this program are summarized in Figure 41 and the details are outlined below.



### **Non-Autoclave Curing Composites**



---

#### **Recommended R&D**

- ◆ Develop Building Block Experimental Test Program to fabricate a series of Composite Structures from flat Plates to Subscale Tank using low permeability and microcrack resistant resin
- ◆ Based on the Building Block Experience, Develop the Fabrication Technology to Make a Full Size Cryo Tank by out of Autoclave Process
- ◆ Develop and Qualify Thermoplastic In Situ Consolidation Process to Fabricate Large Diameter Cryotank (eg. 33 ft diameter for the Ares V Launch Vehicle)
  - Fabrication of composite laminate with thermoplastic resin
  - Qualification of composite for permeability and microcracking
  - Address Honeycomb-skin bonding issues
  - Address other fabrication issues

**Figure 41 – Recommendations for Non-Autoclave Curing Composites**

### **h(1). Phase Ia. Laminate Qualification Issue: Permeation and Microcracking**

Data describing the permeability of IM-7/PEEK laminates are available only at room temperature. In Cogswell, reference 6, Thermoplastic Aromatic Polymer Composites, Butterworth-Heinemann Ltd, 1992, the permeability of PEEK composites was measured against hydrogen in the 25°C to 60°C temperature range. Following three days of saturation, the permeability in mol/m\*s\*bar was 7.2E-12 at 25°C, 9.4E-12 at 40°C, and 15.1E-12 at 60°C.

Accudyne has had outstanding success in fabricating microcrack free laminates but is unaware of data describing the potential for microcracking following thermal cycling of IM-7/PEEK laminates to cryogenic temperatures.

The lack of microcrack and permeability data on IM-7/PEEK laminates following thermal cycling at cryogenic temperatures needs to be addressed. The following activity is recommended:

1. Select a thermoplastic (TP) matrix resin (e.g., APC-2 PEEK or other semi-crystalline or noncrystalline thermoplastic) that will meet cryotank requirements, reference 7. Assume for this report that PEEK is selected.
2. In-situ fabricate flat IM-7/PEEK laminates using the 3" Accudyne ATP heated head now running at LaRC; precondition with 10 thermocycles between -423°F and RT; conduct LH2 permeability with unloaded and loaded specimens using loads that simulate key launch/flight conditions; screen for microcracks via standard optical methods.
3. The Accudyne heated head is capable of placing and in-situ consolidating thin metal foils. Repeat step 1 with IM-7/PEEK panels fabricated with one layer of a thin metal foil in-situ placed in the center.
4. Conduct standard mechanical tests on cryocycled flat laminates.

## **h(2). Phase Ib. Honeycomb-Skin Bonding Issues (Assume IML Tool)**

Previous experience fabricating honeycomb panels by heated head ATP was with Ti honeycomb. Experience with Korex™ core is needed. At the same time, because of the tooling complexity with large cryotanks, procedures must be developed for joining the inner face sheet to the core when IML tooling is used.

The thermoplastic in situ deposition process is capable of placing thermoplastic materials directly over honeycomb core. When Accudyne constructed primary-bonded honeycomb test laminates a meter by meter in size, the structure could be flipped for placement on top of the core in each case, a procedure that was successful at the test laminate level. However, this procedure would be unavailable when fabricating a tank because the inner skin would be affixed to the tool and could not be "flipped" and made available for ATP over core. In this case, Accudyne recognizes the need to develop and demonstrate a process for bonding the core to the inner skin, while the process for bonding to the outer skin would succeed via in-situ placement. In particular, **fusion amorphous bonding** is proposed. In this case, the wide processing window between the Tg of PEEK, 146°C (295°F), and the processing temperature of PEEK, 390°C (734°F), is available to heat and fuse a pre-deposited layer of PEI under vacuum bag pressure between the inner skin and core without deconsolidating the just-placed IMS skin.

The following is recommended:

1. Outer skin-core placement: Using the Accudyne 3" heated head, in-situ place a thin IM-7/PEEK quasi-panel over a selected honeycomb core, e.g., Korex™ (3 pcf, 3/16" ox). Conduct FWT tests on uncycled and thermocycled coupons.
2. Inner skin-core placement: Using the Accudyne 3" heated head, in-situ place the inner skin onto the tool. Then, use fusion amorphous bonding to heat and weld a PEI film pre-deposited between the inner skin and the core with vacuum bag pressure. Placement temperature would be above the Tg of PEEK, 146°C (295°F) but below its processing temperature, 390°C (734°F).
3. Conduct FWT tests on uncycled and thermocycled coupons.
4. Conduct standard mechanical tests on cryocycled flat honeycomb panels containing both outer-and inner-skin/core placements.

## **h(3). Phase IIa: Bonding Skin To Reinforcement Elements**

1. Construct a flat tool covered with an insulating material like G-7. In-situ place a smooth inner skin and secondarily bond the stringers, septums, or frames to the skin using expanding jigs and bonding procedures to be determined. The reinforcing elements can be

thermoplastic or autoclave-consolidated thermosets. Conduct skin-reinforcement element pull-off tests before and after cryocycling.

2. **Potentially Lower Cost Primary Bonding** – Construct a flat tool covered with G-7 as before, but with openings for pre-inserted structural elements. Pre-insert thermoplastic stringers or autoclave-consolidated thermoset elements coated with a surface layer of PEEK film. Using the 3" heated head, place the inner skin of IM-7/PEEK directly onto the tool and over the pre-inserted stringers, septums, or frames, in-situ welding them in place as an integral step in first ply placement. Conduct skin-reinforcement element pull-off tests before and after cryocycling.

#### **h(4). Phase IIb: Tooling and Subscale Tank**

1. Construct a tank subscale open-ended tool with the appropriate support structure and cover it with G-7 (used successfully with laminate placement). The tool is used at room temperature.
2. Based on the downselect from Phase IIa (secondary or primary bonding), place the inner skin of IM-7/PEEK directly onto the tool or over pre-inserted stringers, septums, or frames.
3. Bond honeycomb core to the inner skin using fusion amorphous bonding.
4. Place the outer skin directly over the honeycomb core.
5. Remove the completed tank structure from the tool. If the tank was placed directly over a plain tool, secondarily bond the reinforcing elements.

When these tasks are successful proven with the current deposition head, the next steps would be scaling of the tooling and construction of a wider head for prove out of a subscale tank.

#### **h(5). Phase III: Wider Heated Head Technology**

Up to this point, the Accudyne 3" heated head located at LaRC would have been used. Ultimately, for the fabrication of an Ares V Core LH<sub>2</sub> cryotank, a large deposition head will be required. The purpose of Phase III is to expand the width of the current heated deposition head to 12 inches. The head could be constructed to place tow or tape or be convertible between tow and tape. The head could be constructed to place forty-eight 0.25"-wide tows or four 3"-wide tows. The head would feature conformable compactors to place a gently contoured structure. These conformable compactors would be wider versions of the successful 3-inch wide compactors used today. If severe curvature is required, placement would be accomplished with the current 3-inch wide head.

#### **i. References**

1. Mark B Gruber et al, "Automated Fabrication Processes for Large Composite Aerospace Structures: A Trade Study", SAMPE 2001, Long Beach, CA, May 2001.
2. Bruce, H., Joseph M., M., Jeffrey A., H., Norman J., J., and Mark A., L, "Dry Ribbon for Heated Head Automated Fiber Placement", NASA Technical Report Document ID 20040086973, NASA Langley Technical Report Server, 2000.
3. Mark A Lamontia et al, "Stringer-, Honeycomb Core-, and TIGR-Stiffened Skins, and Ring-Stiffened Cylinders Fabricated from Automated Thermoplastic Fiber Placement and Filament Winding", [http://www.accudyne.com/TPATP\\_JEC\\_2002.pdf](http://www.accudyne.com/TPATP_JEC_2002.pdf).

4. Mark A. Lamontia et al, “Contoured Tape Laying and Fiber Placement Heads for Automated Fiber Placement of Large Composite Aerospace Structures”, <http://www.accudynesystems.com/SAMPE2002.pdf> .
5. Mark A. Lamontia et al, “ The Fabrication and Performance of Flat Skin Stringer and Honeycomb Panels Manufactured by a Thermoplastic Automated Tape Placement Process”, [http://www.accudyne.com/JEC\\_2003\\_Automatic\\_Fiber\\_Placement\\_Head.pdf](http://www.accudyne.com/JEC_2003_Automatic_Fiber_Placement_Head.pdf) .
6. Cogswell FN, “Thermoplastic Aromatic Polymer Composites”, Butterworth-Heinemann, Oxford, 1992.
7. Gregory R Yandek et al, “Reduced Cost Fabrication of Large Composite Aerospace Structures Through Nano particle Modification of thermoplastics”, AFRL-PR-ED-TP-2007-302, August 2007.



## E.3 Non-Destructive Examination (NDE) of Composites

**AS&M** **Non-Destructive Examination (NDE) of Composites** **NASA**

**What is the Issue:**

- Lack of high fidelity standards to establish minimum detectable defects/damage in built-up structural subelements (Joints, load transfer points, etc.)
- Structural Integrity can be compromised by defects/damage introduced in composites during manufacture, subsequent handling, and/or service

**What is Needed:**

- (1) Validated NDE Standards
- (2) NDE to establish failure modes and damage development to support micromechanics modeling
- (3) Development of NDE for bond strength of adhesive joints, kissing bonds and residual stress

**Payoff:**

- NDE Standards for composite structures
- Validation of structural integrity during manufacture and service
- Reduction of certification tests with savings in time and money

**State-of-the-Art**

Promising NDE techniques are ultrasonics, thermography, shearography and acoustic emission

Diagram labels: Radiant Heat Source, Shearography Camera, Image Processing Computer, Honeycomb With Face Sheet to Core Disbond (red), L1-Lens, M1-Mirror/Phase Shifter, M2-Tiltable Mirror, C1-CCD Camera, BS-Beam Splitter

Delta IV LH2 Tank: 18ft. diam, 94ft. length

Laser T™ LM

Figure 42 – Non-Destructive Evaluation of Composites

### a. Issue, Needs and Payoff

The composites for space applications require reliable and rapid large area NDE techniques that can identify different defects on curved surfaces, joints, and discontinuities. Even though a number of techniques are established (Figure 42), high fidelity standards need to be developed and validated. The current state of the art does not provide effective means of nondestructive determination of residual stresses and bond strength of adhesive joints and kissing bonds, requiring further R&D programs. For preparation of NDE procedures, it is often necessary to perform extensive laboratory investigations, in which all potential combinations of part geometry, flaw size and position, probe configurations, etc. are tested. In the future micromechanics modeling tools combined with failure modes and damage development would help to reduce laboratory investigations.

### b. Effect of Defects on Performance

The performance of composite structures for space applications requires identification and elimination of structural vulnerabilities during its manufacture and maintenance phases. Some of the main defects that require identification include delamination, porosity, cracks, inclusions, and

proper cure. Figure 43 lists the type of defects and their effect on the performance of composites, reference 1. Damage to composites is often not visible to eye, unlike a dent in a metal structure. Some hidden damages are due to low velocity impact damage of a sandwich structure that may disbond the skin from the core due to poor adhesion during manufacture, with no visible trace of

Defect	Effect on the Material Performance
Delamination	Catastrophic failure due to loss of interlaminar shear carrying capability
Impact damage	The effect on the compression static strength. Easily visible damage can cause 80% loss and barely visible damage can cause 65% loss
Ply gap	Degradation depends on stacking order and location
Ply waviness	Strength loss can be predicted by assuming loss of load-carrying capability. Fatigue life is also reduced
Porosity	Degrades matrix dominated properties, increases equilibrium moisture level and aggravates thermal-spike phenomena. For example, 1% porosity reduces strength by 5% and fatigue life by 50%
Surface notches	Static strength reduction of up to 50%, local delamination at notch and strength reduction is small for notch sizes that are expected in service
Thermal Over-exposure	Matrix cracking, delamination, fiber debonding and permanent reduction in glass transition temperature

**Figure 43 – Effect of Defects on Composites**

the damage on the surface. Reliable NDE techniques are required to assure the structural integrity of composites to detect any defects and damages introduced during manufacture, handling and service.

### **c. Relevant Techniques**

The NDE is relatively a mature field and Figure 44 lists different techniques and their technology readiness levels, reference 2. Among these, advanced thermography, advanced ultrasonics, reverse geometry X-ray, computed tomography and advanced acoustic emissions are the technologies that need to be further developed and validated for routine inspection of space composites. More details of the techniques and the applicability of the techniques for inspection of composite cylinders can be found in a number of publications, reference 3-5. Further development of the techniques need to focus on the use of these techniques to establish failure modes and damage development to support micromechanics modeling. These technologies will have a large impact on the use of light weight composite structures. Among the emerging techniques, the directional guided wave methodology shows promise to monitor structural property changes due to damage initiation. The main objective is to advance the NDE techniques to detect and predict the effect of defects and damages on the structural integrity of composites. Developments in acoustic,

thermography and other approaches like incorporation of nano sensors are also required to assess bond line defects and bond integrity.

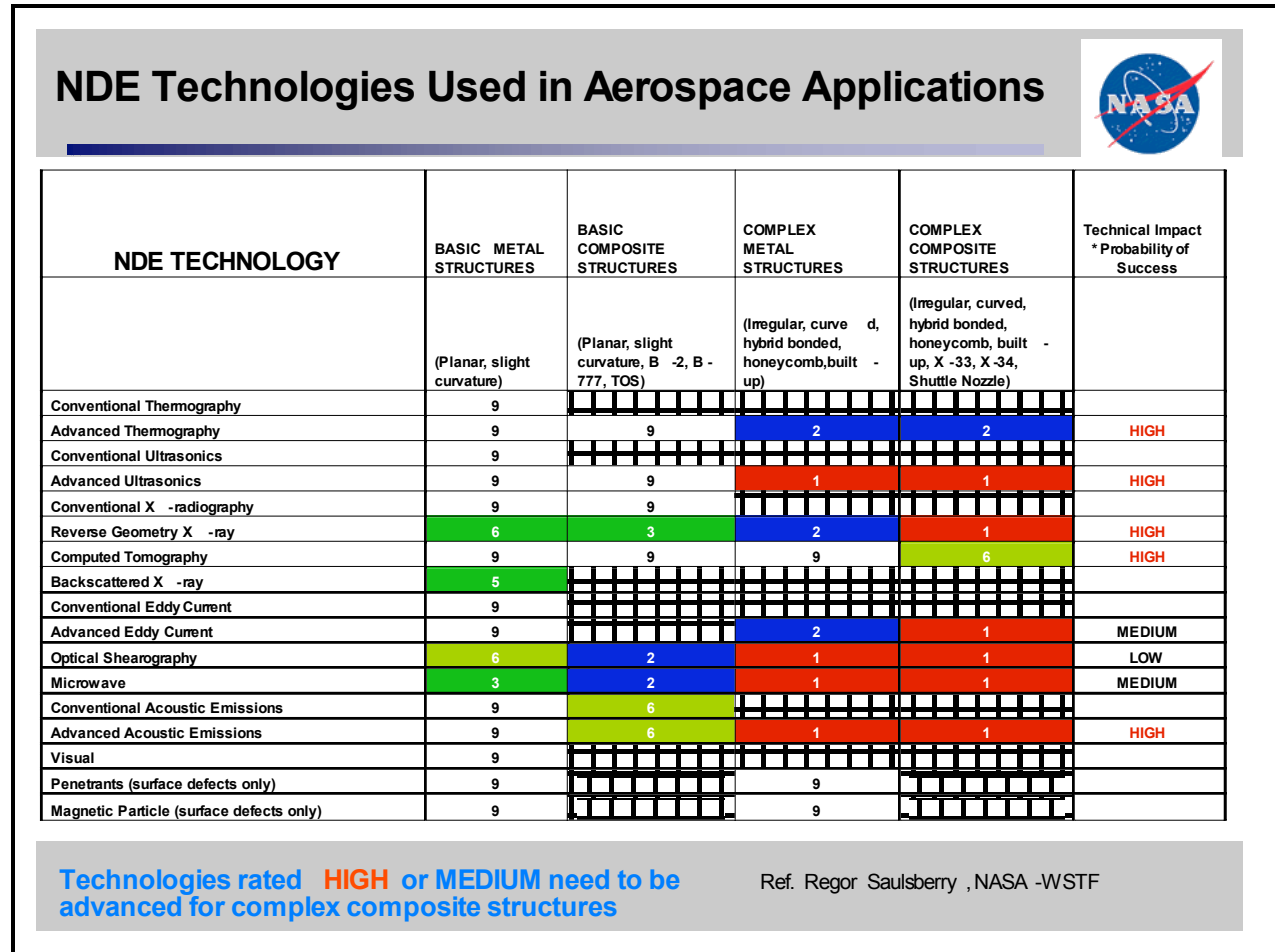


Figure 44 – Relative Maturity of NDE Techniques used to Inspect Aerospace

Techniques such as shearography and laser ultrasonics are well established to inspect large composite structures of different shapes, reference 6. Still, more work is required to develop and validate NDE standards to establish inspection guides for different composite materials, shapes and configurations based on production design. NDE techniques are to be validated with high fidelity standards to establish minimum detectable defect or damage for different composite shapes and sub elements like joints, load transfer points etc. The development of the standards will lead to the establishment of a “Smart NDE Composite Design Guide for Space Structures” covering all aspects of ensuring high quality composite space structures. This would include a comprehensive review of the potential damage states likely to be critical for different structural applications and loading conditions expected during launch, service and environmental effects. The different inspection methods applicable for ensuring high quality for the unique space applications would be examined and classified as to the types and size of imperfections that could be detected by these methods. Hot links to already established inspection and certification protocols would be included. System features desired to minimize the potential for human factors errors in identifying and locating flaws would be identified to aid in developing improved techniques. A readily and easily usable comprehensive literate data base needs to be developed for all techniques.

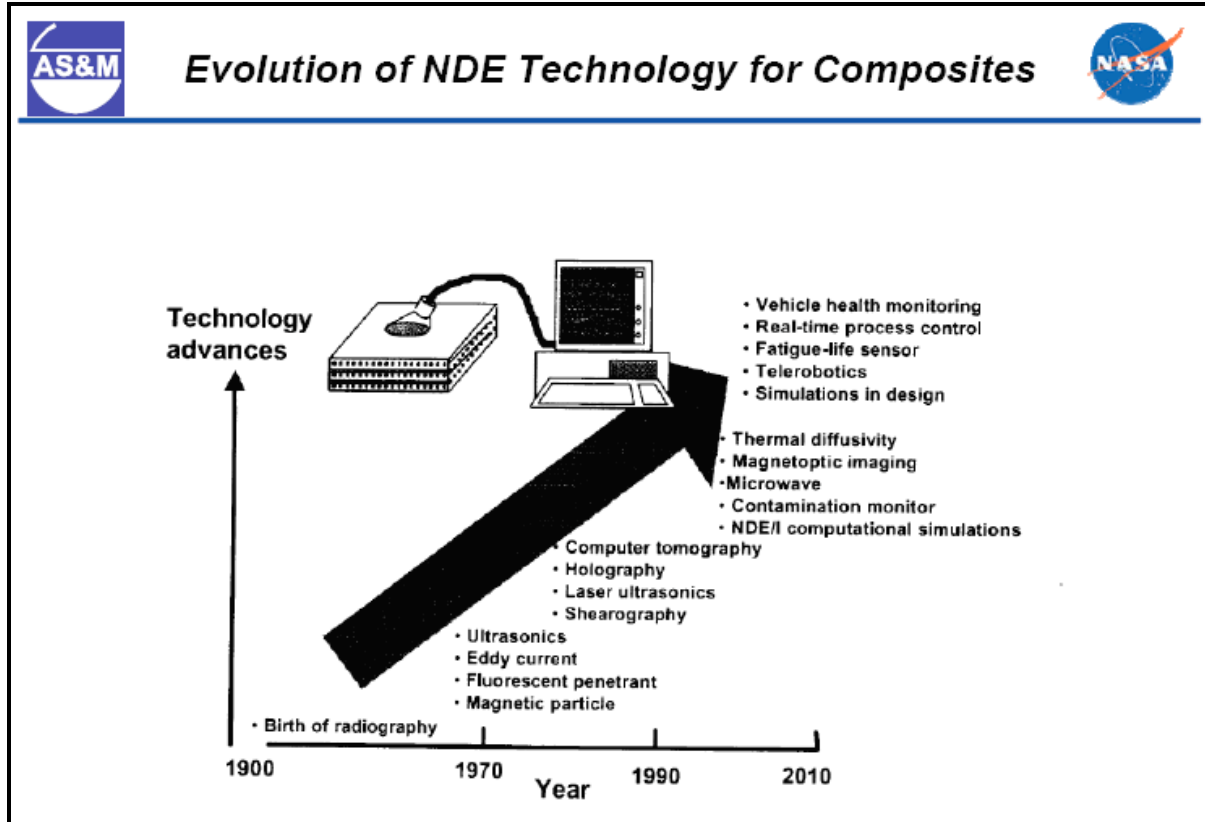


Figure 45 – Evolution of NDE Technologies for Composites

#### d. Simulation and Modeling


NDE techniques are currently used during component manufacturing, design certification, maintenance, inspection, and repair, reference 7. Current research on computer simulations can revolutionize the traditional NDE role, see Figure 45. It is understood that NDE issues not addressed during the component design stage must be addressed later in the manufacturing stage. This staging of the use of NDE procedures can be, potentially, at a much higher cost as maintenance and repair considerations increase with component age. If validated and robust NDE simulations are available during the initial design stage, then component configurations may be adjusted in “real time” to lower the overall life cycle NDE costs while maintaining optimized system level benefits, reference 8. Furthermore, these benefits are enhanced when manufacturing simulations make use of NDE process control simulations. In the future, NDE simulations may be optimized to the point that they may be used to generate the plans for in-service maintainability and repair. Issues such as component design and functional specifications, work space geometry and component access, and accept/reject criteria or retirement-for-cause criteria will need to be incorporated into these NDE simulations, leading to a model based NDE.

Model based NDE links the physical models to structural analyses model to guide inspection operations. The approach would include inspection and health monitoring as an integral part of the design process. It would identify most probable location in the part for critical damage development by examining expected high loading cases combined with areas where complex geometry leads to processing difficulties. The models would then suggest methodologies best suited for getting energy into these areas to ensure adequate inspection and/or alert designers to the diffi-


culty of inspecting these areas which could lead to adding sub-element tests to the building block approach to ensure that the process used gives a robust defect free laminate in those areas. Such a model based NDE will lead to a predictive NDE methodology, as opposed to the currently practiced flaw based methodology.

### **e. Recommendations**

Figure 5 lists the recommended NDE projects to be funded to address high priority needs for composite applications in the Constellation Program. They include the development of standards for the composite material for different structural sub elements classified in terms of configurations based on the manufacturing process. The promising acoustic and thermography techniques need to be further developed to assess the bond line defects. The development needs to combine micromechanics modeling with initiation and propagation of different defects to reliably predict the performance of material and the structure. Such modeling would lead to NDE as a predictive tool for structural integrity.



## ***Advanced NDE Methodologies***



### **Recommended R&D**

- ◆ **Develop high fidelity standards to establish minimum detectable defects/damage in composite laminates, (honeycomb sandwich) and built-up structural subelements (joints, load transfer points, etc.).**
- ◆ **Develop acoustic, thermography, and other approaches for assessment of bond line defects and bond integrity**
- ◆ **Develop directional guided wave (vector inspection) methodology for monitoring changes in a performance parameter due to damage initiation.**
- ◆ **Combine material monitoring measurements with micromechanics models to predict performance changes.**
- ◆ **Explore approaches to move from a “flaw based” methodology to a “predictive” methodology for long service life applications**

**Figure 46 – Recommended R&D in NDE**

### **f. References:**

1. Yoseph Bar-Cohen, “In-Service NDE of Aerospace Structures -- Emerging Technologies and Challenges at the End of the 2nd Millennium”, NDT, Vol. 4, 9, September 1999, <<http://www.ndt.net/article/v04n09/bcohen/bcohen.htm>>
2. Regor Saulsberry, “NASA Perspective on NDE for Aerospace Composites Needs” NASA-WSTF Presentation

3. Karen Fisher Mason, “Nondestructive Testing Broadens Its Scope”, High Performance Composites, May 2006 <http://www.compositesworld.com/hpc/issues/2006/May/1309>
4. Peter Cawley, “Inspection of Composites – Current Status and Challenges”, ECNDT 2006-Mo.2.6.1 <http://www.ndt.net/article/ecndt2006/doc/Mo.2.6.1.pdf>
5. “Examination of The Nondestructive Evaluation of Composite Gas Cylinders”, A7621-18:CRC-CD8.1, Final Report, NTIAC, Texas, September 2002
6. Robert Rivard, “NDE Development Activities”, Northrop Grumman Inc, May 2004
7. Charles E. Harris, James H. Starnes, Jr., and Mark J. Shuart, Langley Research Center, Hampton, Virginia : An Assessment of the State-of-the-Art in the Design and Manufacturing of Large Composite Structures for Aerospace Vehicles, NASA/TM-2001-210844
8. Generazio, E. R., and Harris, C. E., —The Role of Modeling and Simulation in the Development of Advanced Nondestructive Evaluation Systems,” The Aeronautical Journal, Vol. 103, No. 1025, 1999, pp. 325-328

## E.4 Structural Health Monitoring (SHM)

### Structural Health Monitoring (SHM)

**State-of-The-Art**

**What is the Issue:**

- Non-Visible Impact damage and environmental degradation can compromise structural integrity
- Operational safety of lunar surface systems

**What is Needed:**

- Real time NDE of composite structures
- Highly reliable sensors and instrumentation to detect, communicate and classify damage events
- Validation of sensors in simulated service environment
- Calibration standards to fingerprint potential damage states

**Payoff:**

- Quality assurance of structural integrity from fabrication to retirement from service
- Early detection of changes in composite performance
- SHM performance databases to guide new designs and materials to reduce weight


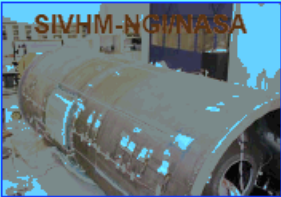
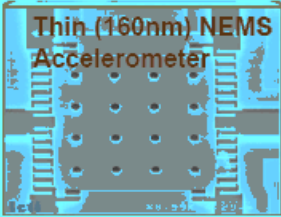


Figure 47 – Structural Health Monitoring

### a. Issue, Needs and Payoff

Space composite structures are subjected to large temperature changes and impact damages caused by space debris and micrometeoroid. The operational safety of the structures requires non destructive real time monitoring of any structural degradation and damage. Real time monitoring of any adverse change in the structure requires the development of a Structural Health Monitoring (SHM) system (Figure 47) with the ability to detect and interpret adverse changes in a structure. The SHM system consists of a number of reliable sensors and instrumentation to detect, communicate and classify different damage events. The sensors need to be validated to operate reliably in space environment.

The implementation of SHM will improve reliability and life of composite structures by early detection of changes in composite performance and early implementation of remedial action.

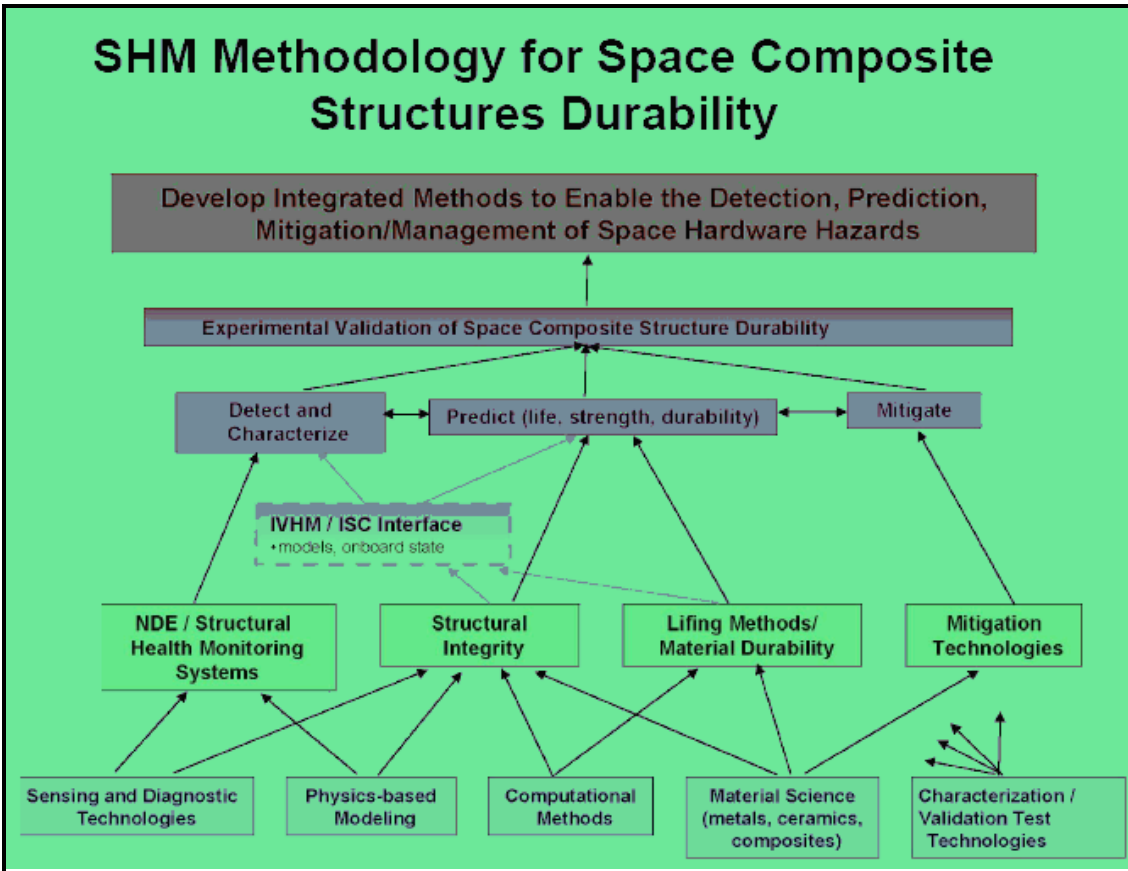


Figure 48 – SHM Methodology for Space Composite Structural Durability

**b. SHM Methodology**

A significant amount of work has been carried out in SHM systems to detect sub-surface damages in composites. The work included the use of fiber optic sensors, embedded micro sensors, embedded piezoelectric sensors, and wireless condition monitoring systems. These sensors are of different sizes (dimension ~ 0.1 to 100 mm) and can detect different damages of sizes around the same range of 0.1 to 100 mm, reference 1.

An intelligent health monitoring network should include a network of sensors to monitor critical parameters that effect system performance. The sensors should function in an autonomous fashion and conform to restrictions on size, weight, and power consumption. It is also desirable that the sensors be integrated with wireless telemetry for data links to a central processing unit. The sensors could either be passive or powered remotely.

Figure 48 summarizes different aspects of SHM methodology for composite structures based on Aircraft aging and durability project concept, reference 2. Some of the key attributes of an Integrated Health Monitoring effort would include:

- Establish likely material degradation mechanisms and failure modes
- Study and develop onboard sensing technologies
- Study and develop sensor optimization and integration
- Study and develop material prognostics
- Validate and demonstrate health monitoring instrumentation and life extension methodologies



### **c. SHM of Composites**

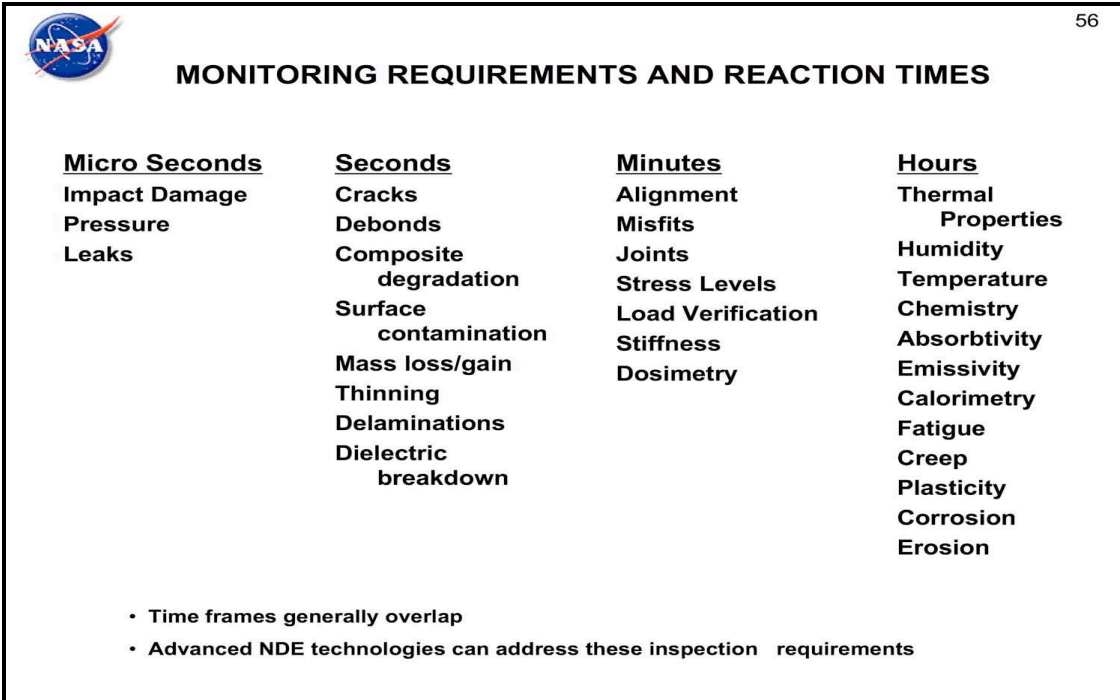
The composite materials generally allow a more flexible SHM system, wherein, the sensors or actuators are embedded and protected in composites. At the same time, the sensors themselves can initiate damage in composites. The properties that can be monitored include detection of impact (localization, intensity), delaminations (localizations, size), debondings (localizations, size), water ingress (localization, intensity), and loads/strain (localization, intensity), reference 3.

Jeffrey Chambers et al , reference 4, have reviewed the standardization procedures to test durability, reliability and longevity of SHM systems in aerospace structures. Seth Kessler, reference 5, has also presented the use of thermography for health monitoring of composite cryogenic tanks. Examples of structural health monitoring technique to reveal delaminations by acoustic monitoring technique, reference 6, and through skin sensing and assessment of defects under composite patching by thermography technique, reference 7, have recently been presented in the Conference on Damage in Composite material (CDCM 2006). Discalea et al, reference 8, discusses the monitoring of the composite wing skin-to-spar joint in unmanned aerial vehicles using ultrasonic guided waves. The study investigates simulated wing skin-to-spar joints with two different types of bond defects, namely poorly cured adhesive and disbonded interfaces. The bond-sensitive feature considered is the ultrasonic strength of transmission through the joints. Both numerical and experimental tests confirm that the ultrasonic strength of transmission increases across the defected bonds.

Northrop Grumman demonstrated the use of structural health monitoring techniques during composite cryotanks proof testing, reference 9. A typical fiber optic sensor installation on the composite tank is shown in Figure 1 (SIVHM-NGI/NASA). Study results are:

- Integrated Large Fiber Optic Sensor Arrays onto Composite Cryotank and installed greater than 6000 Fiber Optic Sensors (Strain & Temp) in less than 70 hrs
- Developed 3D Visualization For Cryo tank Strain and Temperature
- Validated Fiber Optic Strain and Temperature Imaging
- Identified Scale-up Issues and developed Design and Hardware Improvements
- Validated Hydrogen Leak Detection in Tank Core Vacuum Plumbing
- Demonstrated Acousto - Ultrasonic Method on Cryogenic Structure

Further work is required to integrate fiber optic sensors with manufacturing and integrate hydrogen leak sensors closer to the structure. All the sensors require validation in dynamic environment (flight test) and software requires optimization. The choice of the sensors is also dictated by the reaction times of the monitoring requirements as illustrated in Figure 49, reference 10.



**Figure 49 – Monitoring Requirements for SHM and Reaction Times**

#### **d. Constellation Requirements**

For a Constellation Element SHM would entail the following features:

- Permanently installing micro sensors (eg. Thin NEMS accelerometer - Figure 47)
- Continuous monitoring in real time
- Wireless transmission to a central station
- Instantaneous interpretation of sensor data
- Detection of unacceptable material damage at critical high stress locations
- Monitoring of evolution of material damage into critical size
- Growth prediction by a probabilistic damage development procedure
- Adjustments for any detected damage state at prescribed intervals
- Probabilistic forecast of lifetime

The requirements of such an integrated SHM were addressed in a project Abbott et al of CSIRO, Australia, sponsored by NASA Langley Research Center, reference 11. The report examined the concepts for intelligent integrated sensing, processing, communication and decision-making systems that could perform the distributed health monitoring functions of a smart vehicle. The reports presented a list of the types of threats, to which an aerospace vehicle is subject, general strategies for detecting them and or their consequences, and to identify the quantities that must be measured for implementation of these strategies. CSIRO group carried out further work and built an experimental structural health monitoring (SHM) concept demonstrator and test-bed system (CD) for the detection of high-velocity impacts (NASA NDE/IVHM Concept Demonstrator in Figure 47). The test-bed can serve as a tool for research into sensor design, sensing strategies, communication protocols, and distributed processing using multi-agent systems. The distinguishing feature of this system is that its architecture is based on a complex multi-agent system and its behaviors and responses are developed through self-organization. It has no central controller.

This approach endows the system with a high degree of robustness, adaptability and scalability, reference 12. Further work is required to build an intelligent SHM system and test them based on the demonstrator test bed system.

### e. Recommendations

Taking into account of the importance of SHM and the current status of technologies, the recommended R&D programs to establish a reliable intelligent SHM for space composite structures is given in Figure 50. Space composite structures require a system of real time health-monitoring to reduce the periodic inspection and assure operational safety and reliability. Fundamentally, such health monitoring systems should emulate biological systems, with self diagnostic and repair capabilities, where onboard sensors track the structural integrity throughout the life cycle. The life cycle starts from production and continues through service and it is essential to have alarms to indicate that a critical parameter is exceeded. By combining NDE inspections with structural health monitoring (SHM), it would be possible to ensure quality and performance of composites for space applications.

**AS&M** *Structural Health Monitoring (SHM)* **NASA**

**Recommended R&D**

- ◆ Development of an integrated suite of sensors and instrumentation
- ◆ Detection capability (POD) 95%+
- ◆ Sensor design, sensing strategies, communication protocols, and distributed processing using multi-agent systems
- ◆ Manufacturing aspects
- ◆ Maintainability
- ◆ Reparability
- ◆ Self-diagnostic capability
- ◆ Durability – service environment
- ◆ Characterization of damage states
- ◆ Correlation of fingerprint signatures with key property changes
- ◆ Develop calibration standards to fingerprint damage states

Figure 50 – Recommended R&D in SHM

### f. References:

1. Seth S. Kessler, “Structural Health Monitoring of Composite Materials”, Technology Seminar presented at the National Reconnaissance Office, September 4, 2003  
[http://web.mit.edu/sskess/www/ppt/SHM\\_v3.pdf](http://web.mit.edu/sskess/www/ppt/SHM_v3.pdf)
2. Rick Young, “Aircraft Aging & Durability Project – Technical Plan Summary”, Aviation Safety Program, 2006  
[http://www.aeronautics.nasa.gov/nra\\_pdf/aad\\_technical\\_plan\\_c1.pdf](http://www.aeronautics.nasa.gov/nra_pdf/aad_technical_plan_c1.pdf)

3. Holger Speckmann and Christine Brousset, "Structural Health Monitoring – A Future alternative to conventional NDT?", 49<sup>th</sup> Annual Air transport Association NDT Forum, October 2006, [http://www.airlines.org/NR/rdonlyres/D3D05042-BCB1-4FC6-B8B7-EF247F80547A/0/Thurs0930a\\_HolgerSpeckmann.pdf](http://www.airlines.org/NR/rdonlyres/D3D05042-BCB1-4FC6-B8B7-EF247F80547A/0/Thurs0930a_HolgerSpeckmann.pdf)
4. Jeffrey T. Chambers, Brian L. Wardle, and Seth S. Kessler, "Lessons Learned from a Broad Durability Study of an Aerospace SHM system", Proceedings of the 6<sup>th</sup> International Workshop on Structural Health Monitoring, ed by Fu-kuo Chang, Destech Pub Inc. September 2007 <http://web.mit.edu/sskess/www/papers/SHM07c.pdf>
5. Seth S. Kessler, "Cryo-Cooling Thermography: Health Monitoring of Composite Cryogenic Fuel Tanks", Presented to the American Institute of Aeronautics and Astronautics at the Massachusetts Institute of Technology, April 10<sup>th</sup> 1999  
<http://web.mit.edu/sskess/www/ppt/AIAA99.pdf>
6. Martin Lehmann et al, "Monitoring System for Delamination Detection-Qualification of Structural Health Monitoring Systems", Conference on Damage in Composite material (CDCM 2006), Stuttgart, Germany, September 2006,  
<http://www.ndt.net/article/cdcm2006/papers/lehmann.pdf>
7. N.P. Avdelidis et al, "Structural Integrity Assessment of Materials by Thermography", Conference on Damage in Composite material (CDCM 2006), Stuttgart, Germany, September 2006, <http://www.ndt.net/article/cdcm2006/papers/maldague.pdf>
8. Discalea Francesco Lanza et al. "Health Monitoring of UAV Wing Skin-to-spar joints using Guided Waves and Macro Fiber Composite Transducers", Journal of Intelligent Material Systems and Structures, 18, 4, April 2007
9. Bill Sheppard and Donny Wang, "Cryotanks SIVHM Results", Northrop Grumman Inc. May 2004
10. Ed Generazio, "Nondestructive Testing of Fracture and Failure Critical Components", 50<sup>th</sup> Annual Air Transportation Association (ATA) Non-Destructive Testing (NT) Forum, Florida, August 2007  
<http://members.airlines.org/attachments/jmlopez/1%20Ed%20G%20keynote.pdf>
11. Abbott David et al, "Development and Evaluation of Sensor Concepts for Ageless Aerospace Vehicles – Threats and Measurements," NASA-CR-2002-21772 and 21773
12. Don Price, "Development and Demonstration of a Self-organizing Diagnostic System for Structural Health Monitoring," Report 6, Report # CIP 2544, CSIRO Industrial Physics, October 2006.

## E.5 Adhesive Bonding Technology for Extreme Temperature Environments

### Adhesive Bonding Technology for Extreme Temp. Environments

**What are the issues:**

- ◆ Poor bonding of composite adherends leads to microcracking, porosity, water adsorption, poor structural performance, poor fatigue resistance, structural aging/degradation, structural failure, mission failure.
- ◆ NDE methods are inadequate to evaluate adhesive bonds & identify critical flaws.

**What is needed:**

- ◆ Good process control during fabrication, especially for construction of very large h/c structure.
- ◆ Improved NDE processes.

**Payoff:**

- ◆ Low risk of structural failure, either during early phases or during long-term missions.

**State of the Art:**

- ◆ FM300, AF191, & related epoxy film adhesives with standard autoclave cure; ultrasound NDE

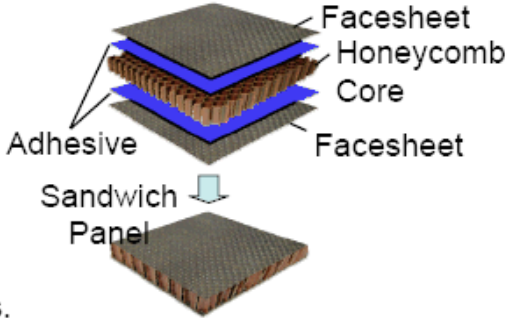


Figure 51 – Adhesive Bonding Technology for Extreme Temperature Environments

### a. Issues, Needs and Payoff

Adhesive bonding of composites is essential for primary load carrying structures. Bonded primary load carrying composite structures have been used in aircraft and space structures for many years. High quality bonds are critical for structural integrity. One of the most important bonding applications for the Constellation Program is the bonding of honeycomb tank structures, see Figure 51. Poor bonding between the honeycomb core and face sheets can lead to microcracking, porosity, water adsorption, poor structural performance and potential mission failure. Process control during fabrication is essential for achieving high quality bonds. Surface preparation is a critical part of this process control. Improved NDE Methods are needed to inspect bonded joints particularly for complex curvature parts. The extreme temperature cycles (cure temperature 350 F to LH2 temperature of -423) experienced for cryogenic applications combined with differences in coefficients of thermal expansion results in high residual stress in bonded joints subjected to these temperature cycles. To reduce the risk of structural failures adhesives optimized for extreme temperature cycles are needed.

## **b. Bonded Joint Technology**

Bonded joint technology is a broad area and covers many different aspects of composite structures. Key considerations include structural strength, effect of bonded joints on frequency response of structures, permeability of gases through bond lines and many other environmental factors. For example the frequency response of a given structure is influenced by section stiffness, bond configuration and type, boundary conditions, and mass distribution. One of the key requirements for the Constellation Program is that bonded joints must be survivable at cryogenic temperatures or temperature extremes expected for the Lunar Environment. They must also survive multiple thermal cycles throughout the expected design life of structures. In order to survive launch loads or loads experienced during operations on the Lunar surface joints cannot degrade more than an acceptable amount. Some of the key design and analysis challenges are large thermal mismatch stresses between metal fitting and composites at cryogenic temperature, design and analysis experience is very limited for metal/composite bonded joints at temperatures below liquid nitrogen, and thermo-elastic material properties and strengths for composites and adhesives at cryogenic temperatures are not available and difficult to test for.

As part of the Reusable Launch Vehicle (RLV) Program David Glass, reference 1, conducted tests to evaluate bonding and vacuum sealing of adhesively bonded foam or honeycomb core specimens encased within Gr/Ep composite face sheets. The adhesives evaluated were PR 1664, EA 9394, Crest 3170, FM-300, and HT 435. The conclusions from this study were that viable candidate adhesives are available for cryogenic tank applications, but additional R&D was suggested. In a more recent study Nettles, reference 2, studied the use of the Climbing Drum Peel (CDP) test method as a way to measure the mode I (peeling) fracture toughness of core/face sheet bonds in sandwich structures. Bardis and Kedward, reference 3, have studied the long-term durability of adhesively bonded composite joints. In that study they investigated the effects of (1) chemical contamination from release fabrics, release films, and peel plies during adherent curing, (2) chemical and mechanical effects of abrasion on the fracture toughness and failure modes, and (3) characterization of paste and film adhesives using mechanical test methods. One of their key conclusions was that surface preparation was critical for high quality bonds. Other studies evaluated are shown in references 4-8. One of the issues in assessing the literature on adhesive bonding is the broad nature of the topic and all the many factors that effect bond quality. Because bonding is an integral part of all composite structures it is important for NASA to conduct a comprehensive survey of adhesives and bonding technologies currently used in space applications for both commercial and military applications. Recommendations on an approach to do this assessment are outlined in the following section.

## **c. Recommendations**

It is recommended that NASA conduct or sponsor a broad assessment survey of adhesives used to bond composite structures, see Figure 52. This survey should have the following attributes:

1. Survey the various adhesives and surface treatments used in bonding applications in the Shuttle, other commercial and military spacecraft and launch hardware, and the application in which each adhesive is employed. The following categories of bonded structure shall be included: metal to metal, composite to metal, composite to composite, honeycomb (metal or composite) to facesheet (metal or composite).

2. Assess the state of the art in advanced adhesives used in the manufacture and repair of spacecraft and launch structure.
3. Describe operational issues associated with exposure to fluids, moisture, radiation, and vacuum, repair problems.
4. Survey space hardware manufacturers and adhesive manufacturers and formulators as required; conduct an space-related literature search.
5. Identify the adhesive systems qualified for use in space applications, their non-proprietary chemistry & formulations, material forms, availability, scale-up capability, current in-plant manufacturing, quality control, and inspection methods and related problems.
6. Identify application problems: out-time, tack, drape, application to large hardware surfaces, surface treatment formulations and application.
7. Identify current aging problems (solved or not solved), typical failure modes.
8. Service history of components using adhesive bonding.
9. Identify repair methods and issues related to repair.
10. Identify more technically robust adhesive formulations (e.g., nanotechnology) that might be expected to improve performance such as interfacial adhesion, lightning strike, radiation shielding, etc.

<b>Adhesive Bonding Technology for Extreme Temperature Environments</b>	
<b><u>Recommendations</u></b>	
<b>Topics to be Included</b>	<b>Outcome:</b>
◆ State of the Art of space qualified adhesives for primary structures	◆ Adhesives/bonded structures monogram
◆ Surface treatments	◆ Identification of major contributors to setting Safety Factors typically 1.4 to 2.0
◆ Non-proprietary chemistry & formulations, material forms, availability, scale-up capability, current in-plant manufacturing, quality control, and inspection	◆ Identify more technically robust adhesive formulations and process control
◆ Metal-to-metal, composite-to-metal, composite-to-composite, honeycomb (metal or composite) to facesheet (metal or composite)	◆ Increased confidence in bonded structures
◆ Manufacture and repair	
◆ Environmental Issues – fluids, moisture, radiation, etc.	
◆ Out-time, tack, drape, application to large hardware surfaces, surface treatment formulations and application	
◆ Repair methods	
◆ Failure modes	
◆ Bonded structure needs	

**Figure 52 – Space Adhesives Assessment for Extreme Temperature Environments**

#### **d. References**

1. Glass D. E. "Bonding and Sealing Evaluation for Cryogenic Tanks," NASA CR 201734, August 1997.
2. A.T Nettles et al, "Using the Climbing Drum Peel (CDP) Test to Obtain a  $G_{IC}$  Value for Core/Face Sheet Bonds, Journal of Composite materials, 41, 24, 2863-2876, 2007.
3. Jason Bordis and Keith Kedward, "Effect of Surface Preparation on The Long-Term Durability of Adhesively Bonded Composite Joints," DOT/FAA/AR-03/53, Jan. 2004.
4. Thomas S Gates et al, "Facesheet Delamination of Composite Sandwich Materials at Cryogenic Temperatures", Composite Science and Technology, 66, 14, 2423-2435, November 2006
5. William L Ko, "Debonding Stress Concentrations in a Pressurized Lobed Sandwich-Walled Generic Cryogenic Tank", NASA/TP-2004-212849, May 2004
6. Nguyen Bao, "Cryotank Skin Stringer Bondline Analysis", NASA Document ID 19990040432, May 1999
7. Andrew Bartoszyk, "Current Progress on the Design and Analysis of the JWST ISIM Bonded Joints for Survivability at Cryogenic Temperatures", FEMCI 2005 Workshop, May 2005 [file:///E:/Adhesives/Bartoszyk-ISIM\\_Bonded\\_Joints%202005.ppt#256,1,Current Progress on the Design and Analysis of the JWST ISIM Bonded Joints for Survivability at Cryogenic Temperatures](file:///E:/Adhesives/Bartoszyk-ISIM_Bonded_Joints%202005.ppt#256,1,Current%20Progress%20on%20the%20Design%20and%20Analysis%20of%20the%20JWST%20ISIM%20Bonded%20Joints%20for%20Survivability%20at%20Cryogenic%20Temperatures)
8. Nettles A.T, "Permeability Testing of Composite Material and Adhesive Bonds for the DC-XA Composite Feedline Program", NASA TM-108483, March 1995



## E-6. Lunar Surface Systems

**AS&M** **Advanced Composites Offer Significant Mass Savings for Numerous Lunar Surface Systems** **NASA**

**What is the Issue:**

- All surface elements must be delivered on Lander  
Mobility Chassis, Manipulator Arm, Lander Structure  
Power, Pressurized Rover, Habitats, Antennas
- Lander can deliver less than 2/3 required mission payload
- Lack of design experience and heritage hardware
- Cyclic temperature excursions -233°F to 128°F

**What is Needed:**  
Lightweight, deployable, composite structural concepts

- Validation of materials, fabrication & hardware performance
- Documented analysis/design procedures

**Payoff**

- 25 to 50% reduction in system masses
- Program confidence in lightweight hardware
- Rapid insertion of advanced technologies

**State-of-the-Art**

- Small rovers
- Aluminum structure
- Earth civil engineering conservative design procedures
- Numerous paper studies

1


**Figure 53 – Advanced Composites Offer Significant Mass Savings for Numerous Lunar Surface Systems**

### a. Issue, Needs and Payoff


The high cost of delivering mass to the remote lunar surface requires reducing mass and packaging volume of surface systems for transportation on the Lander. Reduction of mass and volume calls for light weight and deployable composite structures that require analysis, design, fabrication and validation of composite materials and structures. The use of composites represents a high payoff for the Constellation program, see Figure 53. Taking lunar habitat as an example, it can be seen that the habitat needs to withstand extreme thermal excursions, radiation, meteorites and lunar dust. Figure 54 describe the requirements, the needs such as use of lunar materials to build durable structures that are easily repairable and the pay off, references 1-3.

### b. Technical Challenges

Although composites are experiencing widespread use in earth applications, lunar environment, surface operation procedures, and new applications present major technical challenges, see figure 55, references 4-5. Lunar structures also differ from those designed for space orbital applications. Most space structures are designed for zero g and experience low mechanical loadings. Lunar structures will be subjected to a gravitational field of 1/6 and will experience high internal loads in many cases.



## Lunar Habitats-Expandable, Deployable, Inflatable



**What is the Issue:**  
Minimum weight protection from

- Extreme thermal excursions
- Radiation
- Meteorites
- Lunar dust

**What is Needed:**

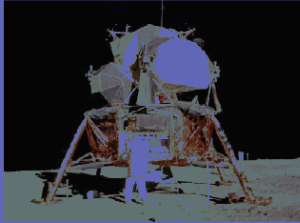
- (1) Light weight deployable structures
- (2) Structures that can be built using lunar materials (Regoliath)
- (3) Repair techniques for structural damages

**Payoff:**


- Safe stay for long periods
- Easy build up of habitats
- Easy repair of any structural damage

**State-of-the-Art**

Apollo Lunar Module



NASA/ ILC Dover LP 12-foot (3.65 meter) diameter inflatable structure



Use of Regoliath or built in shield for passive thermal control and radiation protection






Figure 54 – Lunar Habitats-Expandable, Deployable, Inflatable




## Technical Challenges



**Technical Issues for Advanced Habitats include:**

- [Deployable composite structures](#)
- [Inflatable structures](#)
- [ISRU-derived structures](#), manufacturing processes and construction techniques that can be packaged, deployed and operated in space
- Integrate diagnostic and [habitat health monitoring](#)
- Integrated [self-repairing](#) skins for habitat structures.
- Integrated design techniques that [incorporate advanced systems](#) into the habitat skin/structure and incorporates techniques to adjust resources within the habitat to automatically protect the crew based on the sensed environmental conditions
- Self-healing bladders
- Material properties after long-term exposure to the [extreme environments](#) of space
  - Radiation
  - Long-term loading (creep)








Figure 55 – Technical Challenges

Therefore, much of the prior art of space structures is not directly applicable. In order to minimize cargo volume, most structures will have to be deployable and/or inflatable. In Situ Resource Utilization (ISRU) derived structures, reference 6, manufacturing processes and construction techniques that can be packaged, deployed and operated are required. The designer must deal with a harsh radiation environment, reference 7, micrometeorite impact, reference 8, high cyclic temperature excursions, vacuum, dirt and dust, reference 9, as well as potential damage from crew or robotic handling activities. As consequence, integrated diagnostic and health monitoring, and self repairing and integrated advanced systems that adjust resources within the habitat to automatically protect the crew based on the sensed environmental and habitat conditions are highly desirable.


Major impediments to the development of advanced composite for lunar surface applications are lack of design experience and heritage hardware. The lack of design experience and heritage hardware for guidance may lead to overly conservative designs that do not fully exploit the potential advantages of advanced composites. Thus, composite designs showing marginal or no mass advantage are discarded in favor of more conventional metallic designs.

### c. Recommendations

The recommended R & D programs are listed in figure 56. A conceptual study should be conducted of a number of lunar surface elements that could benefit from the application of advanced composites. From this study select one or more elements for further study that will exercise the various design challenges of advanced composites. For each of the selected elements, detailed analyses, and design methods would be developed for validation by large scale hardware fabrication and testing. The study would result in a monograph for surface habitats, with validated design and construction methods.



## Low Mass Deployable and Inflatable Structures and Materials for Lunar Surface



### Recommended R&D


- ◆ **Deployable, expandable, inflatable structural concepts**
- ◆ **Modular concepts**
  - Habitats, solar shelters, dust barriers
  - Regolith support structure for radiation protection
  - Cranes, antennas, solar power, bridges
- ◆ **Materials required for all concepts**
  - Resins, fibers, adhesives, fabrics, cables, etc.
- ◆ **Environmental tests standards**
  - Radiation, contamination, thermal cycling, etc.
- ◆ **Validated and documented design methods**
- ◆ **Monograph for surface habitats**

**Figure 56 – Recommended R&D Programs for Low Mass Deployable and Inflatable Structures and Materials for Lunar Surface**


## d. References

1. Sahil Ambani et al, "Lunar Settlement Structures," <http://www.osd.rutgers.edu/gs/07papers/lunar.pdf>
2. Ruess F et al, "Structural Design of a Lunar Habitat," Journal of Aerospace Engineering, Vol. 19, 3, July 2006
3. Nancy J. Lindsey, "Lunar station protection: Lunar Regolith Shielding", International Lunar Conference 2003, Hawaii, November 2003  
<http://www.rcktmom.com/njlworks/LunarRegolithPprenvi2.html>
4. Kris Kennedy, "Architecture, Habitats & Integration", in Engineering Deans Conference 2006, NASA Johnson Space Center, Houston, Texas, Oct 2006  
<http://research.jsc.nasa.gov/presentations/HabitableSysandStructsDeansConf.ppt#295,1,Slide 1>
5. "Rutgers Symposium on Lunar Settlements, Organized by Rutgers University and AIAA, June 2007 <http://lunarbase.rutgers.edu/program.php>
6. NASA In-Situ Resource Utilization (ISRU) Capability Roadmap Final Report, Chair: Gerald B. Sanders, May 2005  
[http://www.lpi.usra.edu/lunar\\_resources/documents/ISRUFinalReportRev15\\_19\\_05%202\\_.pdf](http://www.lpi.usra.edu/lunar_resources/documents/ISRUFinalReportRev15_19_05%202_.pdf)
7. Francis A. Cucinotta et al, "Managing Lunar and Mars Mission Radiation Risks, NASA/TP-2005-213164, July 2005
8. Cynthia Belk et al, "Meteoroids and Orbital Debris: Effects on Spacecraft", NASA RP-1408, August 1997
9. Sandra A. Wagner, "The Apollo Experience Lessons Learned for Constellation Lunar Dust management", NASA/TP-213726, September 2006.

## E.7 High Fidelity Analyses for Advanced Composite Structures



# Validated High Fidelity Analyses Key to



## Reduced Knockdown Factors

**What is the Issue:**  
Current design practices are commonly overly conservative with high knockdown factors for both buckling and fracture. No available rational knockdown factors for composite shells

**What is Needed:**

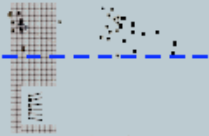
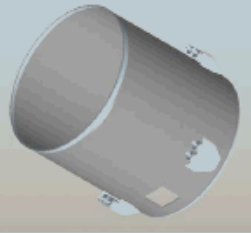
- Analysis based knockdown factors.
- Establish knockdown factors for composite shells based on tests of last 25 years.
- Modern high fidelity shell test results.
- Damage tolerance experimental data base on current composite material systems

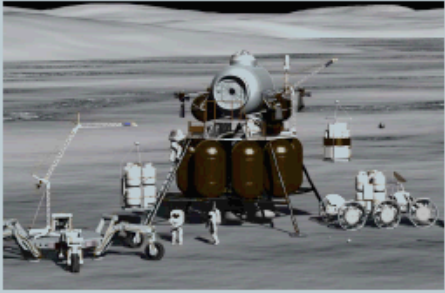
**Payoff:**

- Reduced knockdown factors leading to higher mass savings
- Improved programmatic confidence for the widespread application of composites

**State-of-the-Art**

- Cylinder knockdowns based on tests results from the 1930 to the 1960.
- Damage tolerance knockdowns based on old material systems



**Figure 57 – Validated High Fidelity Analyses Key to Reduced Knockdown Factors**

### a. Issue, Needs and payoff

It is widely recognized that the use of advanced composites in the Constellation program will result in mass savings per component on the order of 20 to 40%. The major reason for this mass savings is the lower density of the composite material. The lower range of the expected weight savings results from the use of overly conservative knockdown factors. These conservative knockdown factors are the result of low confidence in available analytical tools for accurately predicting the failures of composite structures. To achieve the higher potential weight savings of advanced composites, it will be necessary to develop validated high fidelity analyses as shown in Figures 57, 58, and 59. The two critical areas for improved analytical procedures are shell buckling and damage tolerance. In this section a discussion is presented of the advancements needed in these two areas. Validated high fidelity analysis would help to increase more use of composites with reduce the payload mass.

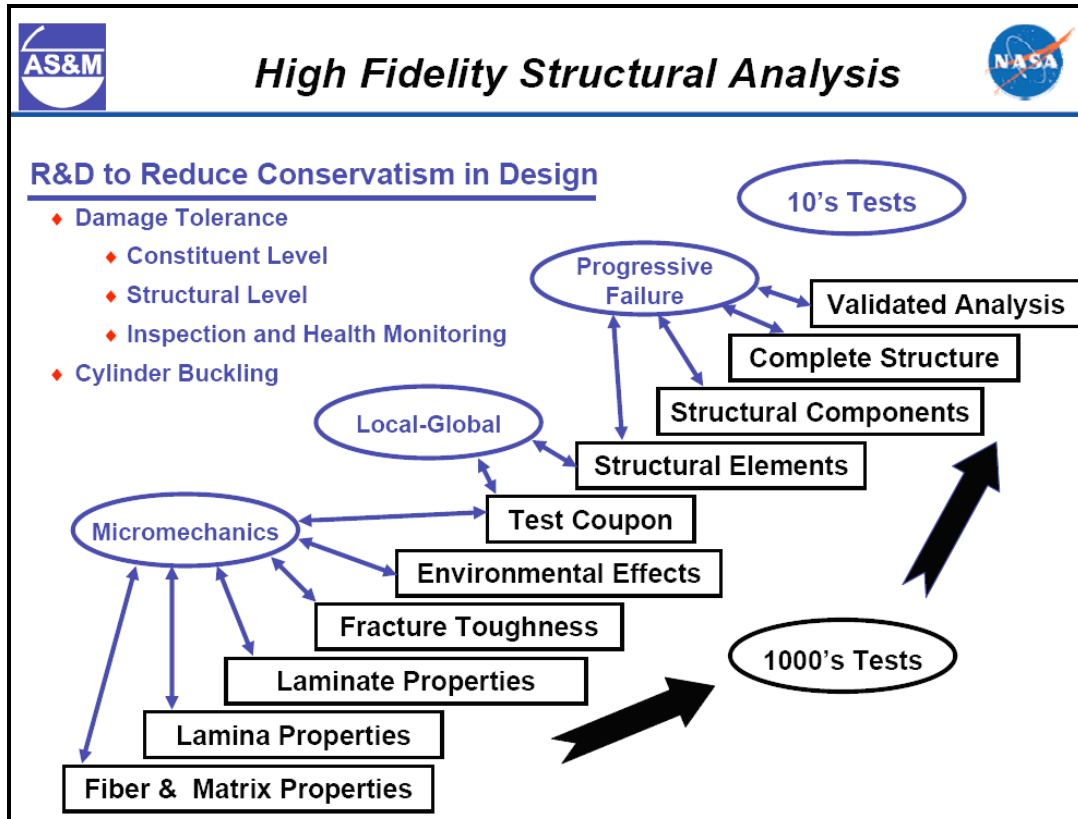


Figure 58 – High Fidelity Structural Analysis

### b. Validated High Fidelity Analyses for the Buckling of Advanced Composite Structures

Because of the large number of cylindrically shaped structures being used in the Constellation program, this represents an obvious area in which to pursue mass savings. To achieve mass savings in cylinders, it is important that validated, accurate buckling prediction methods exist. Cylinders are very efficient structures because the curvature acts to stabilize the shell against wall buckling. However, this increased load carrying capability comes at the expense of making the structure more sensitive to deviations from ideal conditions. For example, shape imperfections, pre-buckling deformations, and proper boundary conditions, can all result in incorrect prediction of buckling loads as discussed in references 1 and 2. Over the years, the effects for metal cylinders have been dealt with by applying statistically juggled empirical knockdown factors. This necessarily results in conservative designs in most cases. With the advent of composites, these metallic knockdown factors have been applied to composite cylinders in an ad hoc fashion. Thus, efficient design of composite cylinders using such knockdowns is not possible. An approach for improving this situation is discussed in reference 1. This approach involves a series of new composite cylinder tests as well as including composite test data achieved over the past 25 years to obtain a hybrid deterministic/statistical means for establishing knockdown factors. This recommended approach is highly endorsed.

In the past, numerous structural test programs have been conducted in a parametric fashion. For example, structural dimensions were varied in controlled fashion to determine the effect on buckling loads. This approach although effective, is quite inefficient, and for composites would be

prohibitively expensive. In lieu of this, it is recommended that a cylinder weight strength chart be established for composite cylinders to assist in test article selection. An example of

## Composite Structures Prediction Methods Status

- **Cylinder buckling**
  - Analysis with empirical knockdown factors
  - Nemeth/Hilburger/Rouse have excellent program to improve this area
  - This activity is strongly endorsed
- **Notch strength**
  - Empirically established fracture parameters
  - Inadequate non-proprietary notch strength data base for modern composite system, e.g., IM7/977-2
- **Laminate strength and stiffness\***
  - Numerous micro and macro analysis tools available and used
  - No single tool is uniformly used and certified such as SQ 5 in the past
  - Complete set of empirical fiber, resin, laminate and fabric data needed to enable rational stiffness and strength prediction methods for IM7/977-2 laminates and structures

*\* Observations from consulting over the past 15 years on numerous aerospace advanced technology structures programs*

Figure 59 – Composite Structures Prediction Methods Status

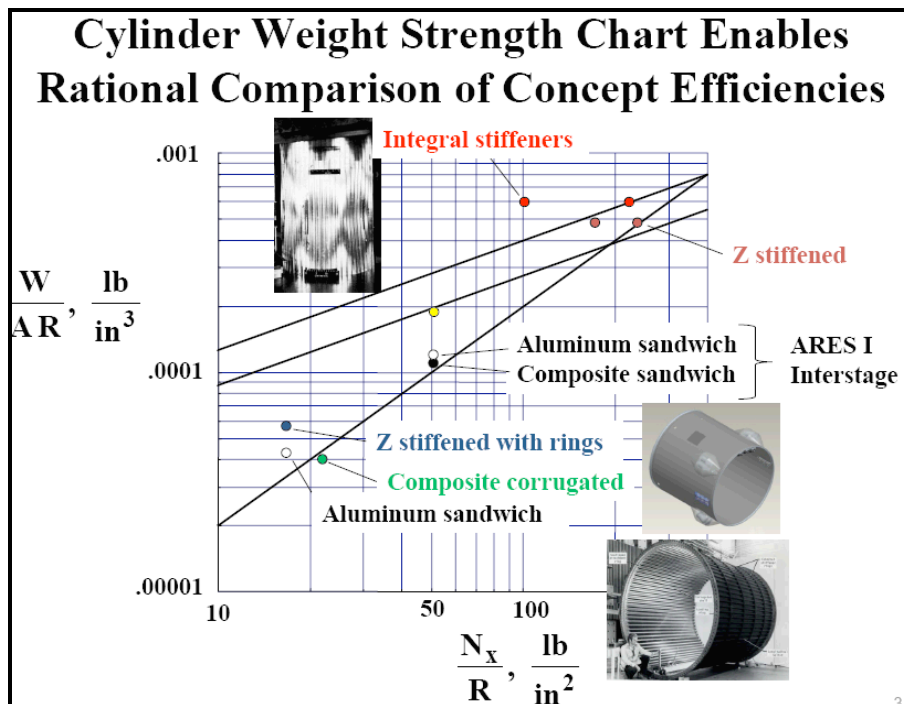


Figure 60 – Cylinder Weight Strength Chart Enables Rational Comparison of Concept Efficiencies

such a chart is presented in Figure 60. The upper line on the chart represents the buckling of a monocoque aluminum cylinder, while the line under it represents the buckling of a monocoque composite cylinder with a homogeneous pseudo-isotropic wall. The lower line is the yield cut off for an aluminum cylinder with a yield stress of 50, 000 psi. Data for several cylinder concepts are presented on the chart to demonstrate its applicability. A major need is to fully populate this chart with available composite cylinder data to assist in guiding future experimental studies.

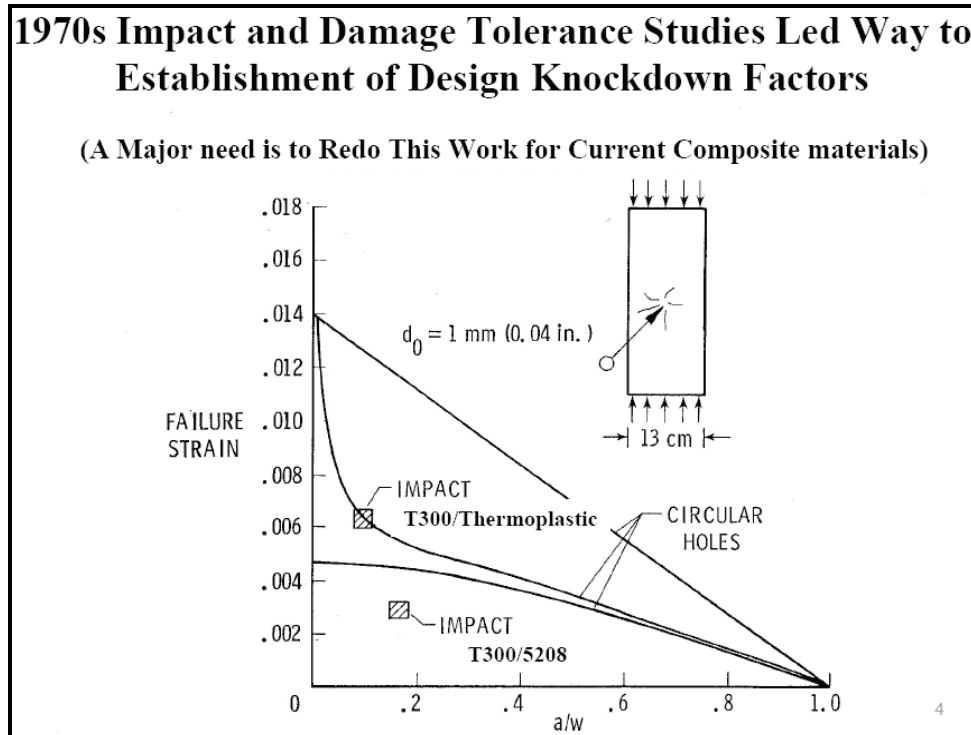
### **c. Validated High Fidelity Analysis for Damage Tolerance of Advanced Composites**

It is well recognized that a widespread application of advanced composites to the Constellation program would result in critically needed mass savings. However, in the extensive application of advanced composites to numerous components of the constellation program, they are exposed to new and an ever increasing variety of threats. Although composites have high strength and stiffness with new tougher resins, they remain relatively fragile and must be designed to handle flaws resulting from numerous damage scenarios as well as cutouts, discontinuities and processing imperfections. The ability of a structure to survive in the presence of such flaws is referred to as damage tolerance. Early composite systems such as T300/5208 are sensitive to relatively small flaws and low impacts because of the brittle nature of the resins. In recent years, composites with tougher resins, e.g., IM7/977-2 have shown promise in improving damage tolerance.

Although IM7/977-2 is being used by Boeing in its new aircraft and in other industrial applications, the damage tolerance empirical data base remains unavailable to the Constellation program because of proprietary restrictions. To establish the needed confidence in advanced composites, and to develop validated flaw failure prediction methods, it is necessary to establish an extensive, widely available, damage tolerance empirical data base. In order to establish this data base in an efficient and cost effective fashion, a steering group consisting of fracture experts, designers, and users should be established to guide its development. This database should be established in such a fashion that a direct damage tolerance performance comparison is made to show improvements from previous composite material systems. Some prior research in this area is presented in references 4 through 8.

An example of the type of data needed is from reference 5, Figure 11 and is presented here in Figure 61. The lower data point was for T300/5208, while the higher data point was for the same fiber with a thermoplastic resin. Although the thermoplastic resin was not considered to be viable for structural applications at that time, it was a tough resin, and demonstrated a significant improvement in damage tolerance compared to the T300/5208 system. References 7 and 8 present design procedures aimed at selecting laminate layups that further improve damage tolerance for a given composite material system. Although these studies show promise, the work is theoretical in nature and will require experimental verification.







**Figure 61 – 1970’s Impact and Damage Tolerance Studies Led Way to Establishment of Design Knockdown Factors**

#### d. Recommendations

Recommended R&D in High Fidelity Structural Analysis is summarized in Figure 62. Further effort should be expended on first principle micromechanics constituent modeling to obtain better methods for predicting the on set of fracture and subsequent growth to critical levels. An open fracture data base for IM7/977-2 is urgently needed. A composite fracture monograph is needed to evaluated new materials and guide future development. Data on composite cylinders must be compiled and weight strength charts established to benchmark current status and to guide future development of efficient composite cylinders. Shell stability monographs need to be developed to aide future designers and engineers.



## High Fidelity Structural Analysis

### Recommended R&D

- ◆ **First principle micromechanics based on constituent modeling, i.e., strain invariant**
- ◆ **Establish Fracture data base on IM7/977-2 and other candidates**
- ◆ **Develop Composites fracture monographs**
- ◆ **Develop Shell stability monographs**
- ◆ **Compile data and establish weight strength charts for composite cylinders**
- ◆ **Use weight strength charts to assist in guiding future tests of efficient composite cylinders**

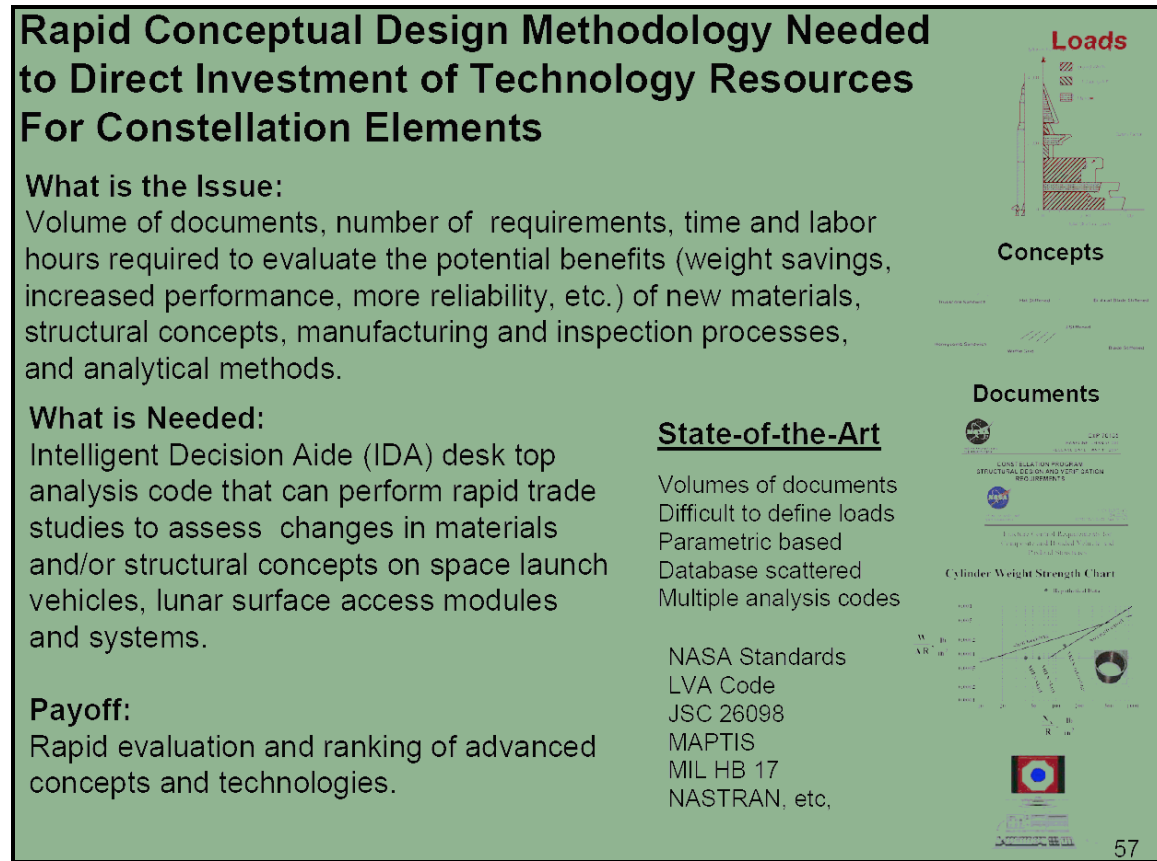
**Figure 62 – Recommended R&D for High Fidelity Structural Analysis**

## **f. References**

1. Nemeth, Michael, and Starnes, James, “The NASA Monographs on Shell Stability Design Recommendations. A Review and Suggested Improvements,” NASA/TP-1998-206290, January, 1998
2. Hilburger, Mark, Nemeth, Michael, and Starnes, James, “Shell Buckling Design Criteria Based on Manufacturing Imperfection Signatures”, AIAA JOURNAL, Vol. 44, No. 3, March 2006
3. Williams, Jerry G. and Mikulas, Martin M., Jr., “Analytical and Experimental Study of Structurally Efficient Composite Hat-Stiffened Panels Loaded in Axial Compression,” AIAA Paper No. 75-754, presented at the ASME/AIAA/SAE 16th Structures, Structural Dynamics, and Materials Conference at Denver, Colorado, May 27-29, 1975
4. Mikulas, Martin M., Jr., Bush, Harold G. and Rhodes, Marvin D., “Current Langley Research Center Studies on Buckling and Low-Velocity Impact of Composite Panels,” NASA TM X-3377, April 1976
5. Mikulas, Martin M., Jr., “Failure Prediction Techniques for Compression Loaded Composite Laminates with Holes,” NASA CP-2142, August 1980
6. Rhodes, Marvin D., Mikulas, Martin M., Jr. and McGowan, Paul E., “Effect of Orthotropic Properties and Panel Width on the Compression Strength of Graphite-Epoxy Laminates with Holes,” AIAA Paper No. 82-0749, May 1982

7. Mikulas, Martin M., Jr, and Sumpter, Rod, "A New Merit Function for Evaluating the Flaw Tolerance of Composite Laminates," NASA Contractors Report 198253, Langley Research Center, November, 1995
8. Mikulas, Martin M., Jr., and Sumpter, Rod, "A New Merit Function for Evaluating the Flaw Tolerance of Composite Laminates - Part II, Arbitrary Size Holes and Center Cracks", NASA CR -2000, January, 2000

## E.8 Rapid Conceptual Design Methodology (RCDM)



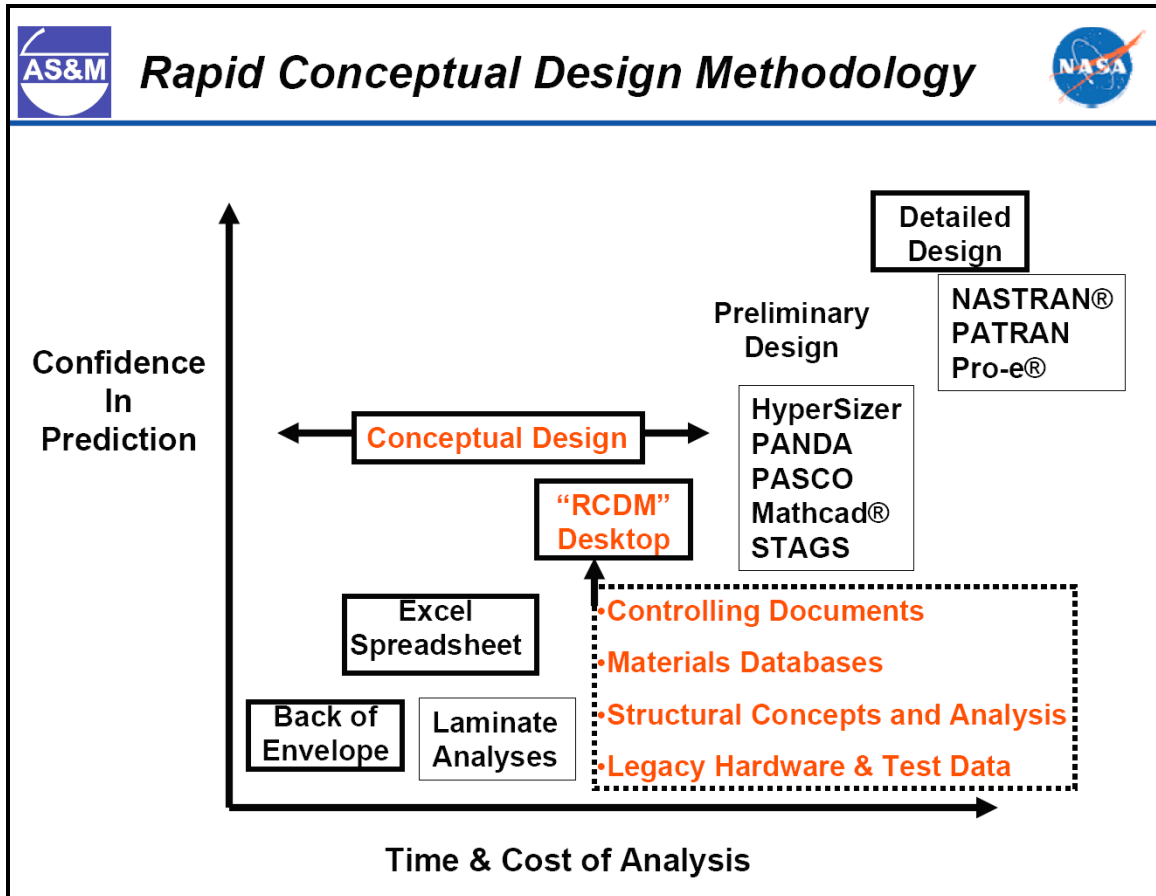
**Figure 63 – Rapid Conceptual Design Methodology Needed to Direct Investment of Technology Resources for Constellation Program**

### a. Issue, Needs and Payoff

Technologists have a very difficult task attempting to predict quantitative benefits of new materials, structural concepts, manufacturing and inspection processes and analytical methods. See Figure 63. Often numerous volumes of controlling documents which are extremely important in final design but may have only a few pages of significant information at conceptual design must be studied to extract pertinent data such as Factors of Safety, test requirements, etc. Loads and/or temperature environments are not readily available. Weights data are mostly parametric based, see reference1, and do not have sufficient detail to assess value of improved material properties, more accurate analysis, reduced Factors of Safety, increased reliability of bonded joints, better NDE methods that detect smaller anomalies, etc.

NASA has begun development of the Constellation Program and there is urgent need to develop an intelligent desk top analysis code that can perform rapid trade studies to assess changes in materials and/or structural concepts for space launch vehicles, lunar surface access modules and systems. Current assessment is that mission goals will require minimum weight for nearly all structural elements.

Figure 64 depicts key features of a proposed Rapid Conceptual Design Methodology (RCDM).



**Figure 64 – Rapid Conceptual Design Methodology**

The RCDM is envisioned to be the Technologist “tool box”. Capabilities should include: (1) Controlling and search technique to identify significant information relative to the material and structure being assessed. (2) Materials databases and means of rapidly changing properties. (3) Built in common structural concepts and analysis and means of rapidly adding new designs. Relevant loads and environments data must be included or a means for calculating each. (4) Catalog of prior space structures and relevant test data.

**b. Recommendations**

Figure 65 summarizes recommended R&D in Rapid Conceptual Design Methodology. An intelligent decision aide search capability to codify all controlling documents for Constellation elements is urgently needed to allow technologists to quickly determine the pertinent design requirements. Desktop Codes capable of predicting loads, environments, failure modes, failure loads, and minimum weight concepts must be linked and/or developed. Codes such as LVA described in reference 2 and HyperSizer Pro™, see reference 3, could be the major building blocks in RCDM. The codes should be such that changes materials and structural concepts, analysis methods, knockdown factors, influence on size of anomaly detectable and health monitoring are easy to make and the change in weight savings predicted. All Legacy hardware and test data need to be collected, stored and used to establish benchmarks.

The RCDM would be an integral part of the Smart Design Guide.



***Rapid Conceptual Design Methodology***

**Recommended R&D**

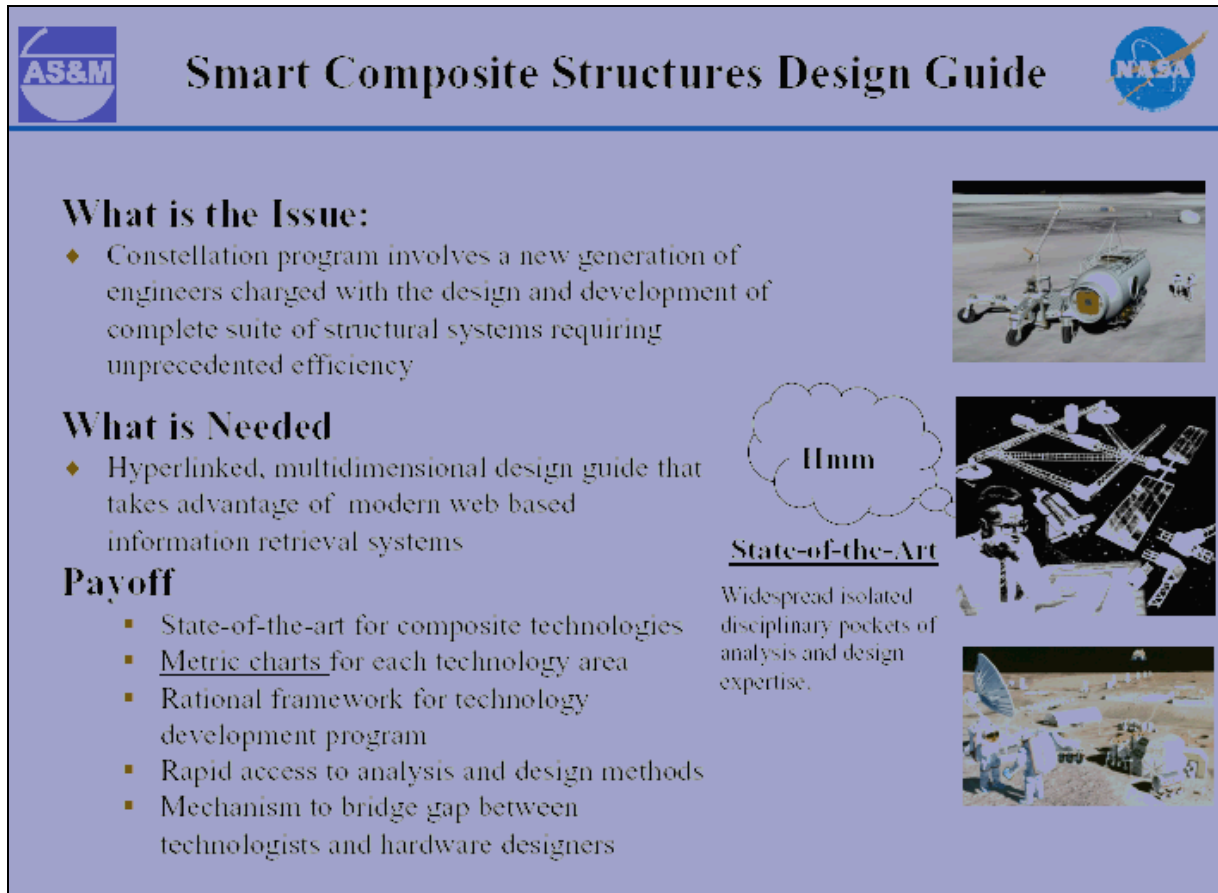
- ◆ **Develop Intelligent Decision Aide Search Capability to Codify Controlling Documentation for Constellation Element Structures**
- ◆ **Link and/or Develop Desktop Codes to Predict**
  - Loads and Environment
  - Failure Modes and Loads
  - Minimum Weight Concept
- ◆ **Quantify Weight Savings Payoff for Improved**
  - Materials and Structural Concepts
  - Analysis Codes and Accurate Knockdown Factors
  - NDE and IVHM
- ◆ **Collect and Catalog Legacy Hardware and Tests Data**

**Figure 65 – Rapid Conceptual Design Methodology Recommendations**

### **c. References**

1. Design Mass Properties II, “Mass Estimating and Forecasting For Aerospace Vehicles Based on Historical Data,” JSC 26098, and Nov. 1994.
2. Wayne, Andrew J. and Philips, Alan D., Compiled by, User’s Manual, Launch Vehicle Analysis (LVA), Release Version 5.1.0, December 17, 2003.
3. HyperSizer Pro™, [http://www.hypersizer.com/dload/pro\\_brochure\\_dl.htm](http://www.hypersizer.com/dload/pro_brochure_dl.htm)

## E.9 Smart Design Guide for Composite Space Structures



The slide features the AS&M logo on the top left and the NASA logo on the top right. The title "Smart Composite Structures Design Guide" is centered at the top. The content is organized into three main sections: "What is the Issue:", "What is Needed", and "Payoff". The "What is the Issue:" section includes a bullet point about the Constellation program. The "What is Needed" section includes a bullet point about a hyperlinked design guide. The "Payoff" section lists five key features. To the right of the text, there are three images: a lunar lander on the surface, a person in a white lab coat looking at a computer screen with a "State-of-the-Art" label, and a lunar base. A thought bubble containing the word "Hmm" is positioned above the person at the computer.

**AS&M** **Smart Composite Structures Design Guide** **NASA**

**What is the Issue:**

- ◆ Constellation program involves a new generation of engineers charged with the design and development of complete suite of structural systems requiring unprecedented efficiency

**What is Needed**

- ◆ Hyperlinked, multidimensional design guide that takes advantage of modern web based information retrieval systems

**Payoff**

- State-of-the-art for composite technologies
- Metric charts for each technology area
- Rational framework for technology development program
- Rapid access to analysis and design methods
- Mechanism to bridge gap between technologists and hardware designers

**State-of-the-Art**

Widespread isolated disciplinary pockets of analysis and design expertise.

Hmm

Figure 66 - Smart Design Guide

### a. Issue, Needs and Payoff

NASA is currently embarking on a major new mission of proportions unprecedented since the APOLLO program. This is a long term mission for man's return to the Moon, and then to Mars. Because of the physical limitations in improving launch vehicle efficiency, it is critical that the mass of launched payloads be kept to a minimum. The widespread use of advanced composites in all elements of the Constellation program will result in critically needed mass savings along with associated reductions in mission costs. To achieve these benefits, however, a long range, balanced composite technology program is needed. To ensure that the information developed from this technology program is well organized, documented, and available to the large teams of engineers that will be required to implement the Constellation program, it is essential to have in place a modern, web-based information retrieval system in which all of the new technology is archived and continually updated. A system for achieving this is referred to as a "Smart Design Guide for Composite Space Structures." The primary features of this smart design guide are shown in Figures 66 and 67.

In numerous past programs, a significant amount of the technology developed at great expense, was lost due to lack of maintaining adequate records. With current computer and web capabilities, the technology is available not only to archive vast records, but to provide a smart and rapid retrieval system for technologists, designers, mission analysts, and program managers.

## **Smart Design Guide is a Computer-Based Interactive Series of Living Monographs**

- **Continually updated**
- **Contributions by relevant experts**
- **Hyperlinked information retrieval environment**
- **Multidimensional modular architecture**
- **Provides:**
  - **State-of-the-art for composite technologies**
  - **Metric charts for each technology area**
  - **Rational framework for technology development program**
  - **Rapid access to analysis and design methods**
  - **Mechanism to bridge gap between technologists and hardware designers**

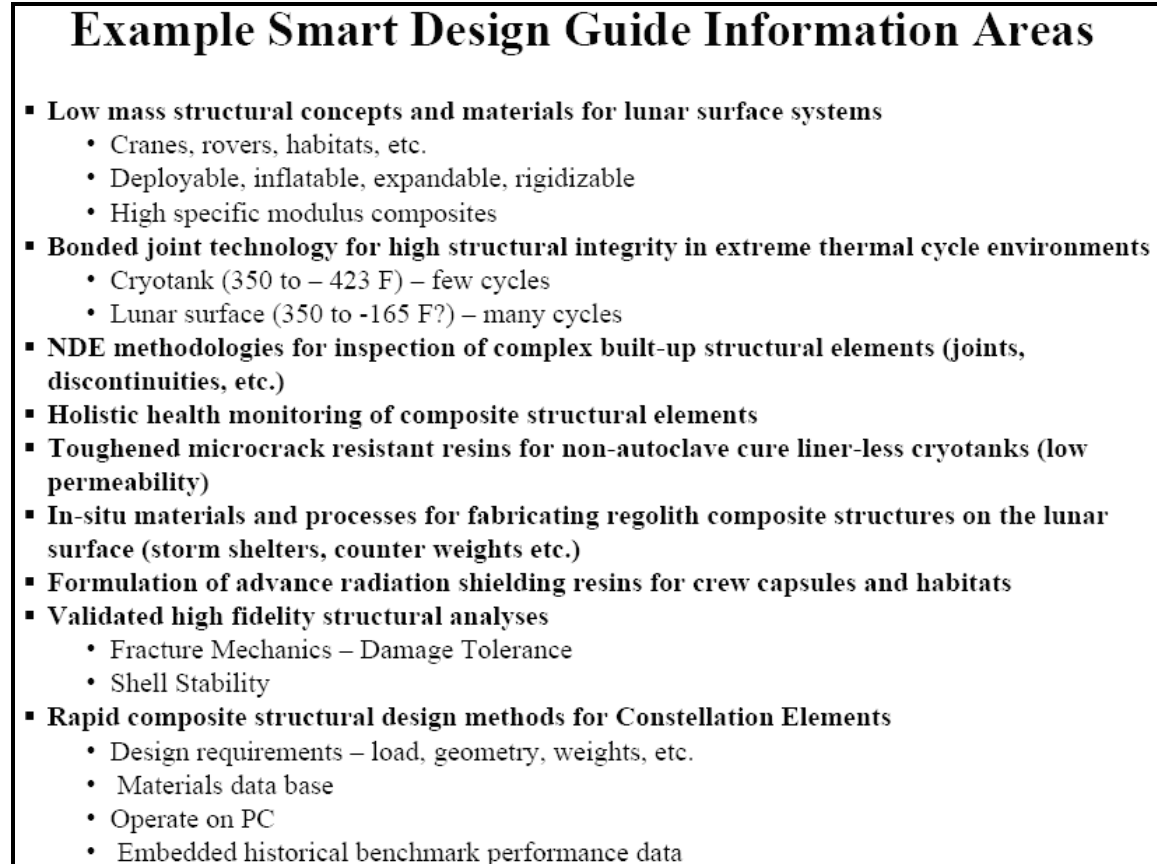
**Figure 67 - Smart Design Guide is a Computer-Based Interactive Series of Living Monographs**

### **b. Methodology**

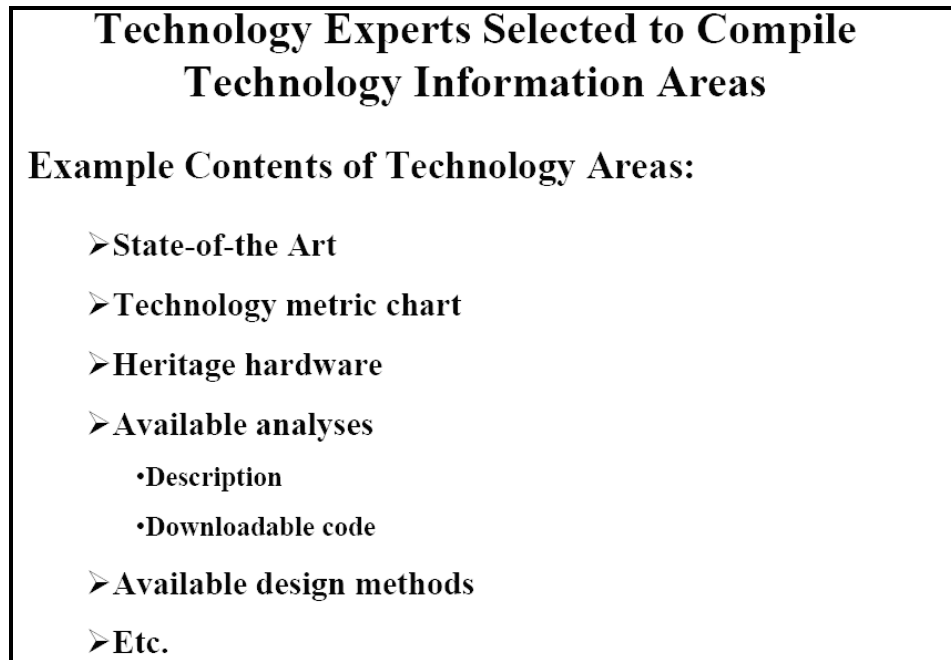
To enhance the value of the smart design guide, experts in selected areas should be chosen to provide monographs that explain the state-of-the-art of the area as well as provide some form of metric chart or means to quantify the performance of available technology. This metric chart would be of value to designers as a corporate knowledge of prior art and also to program managers for guiding investments of future technology efforts.

A suggested list for establishing contributing experts is shown in Figure 68. The monographs in each area could begin quite simply and serve primarily as a starting point for initial subject matter research. The monographs could be expanded over time as experience established needs arise. The general type of information to be included in the monographs is presented in Figure 69. In Figure 70, an example of information retrieval needed for a new structural design is presented. Although the monograph would not include all of this information, it would provide a hyperlink stepping stone from which the information could be obtained.





**Figure 68 – Example Smart Design Guide Information Areas**



**Figure 69 – Technology Experts Selected to Compile Technology Information Areas**

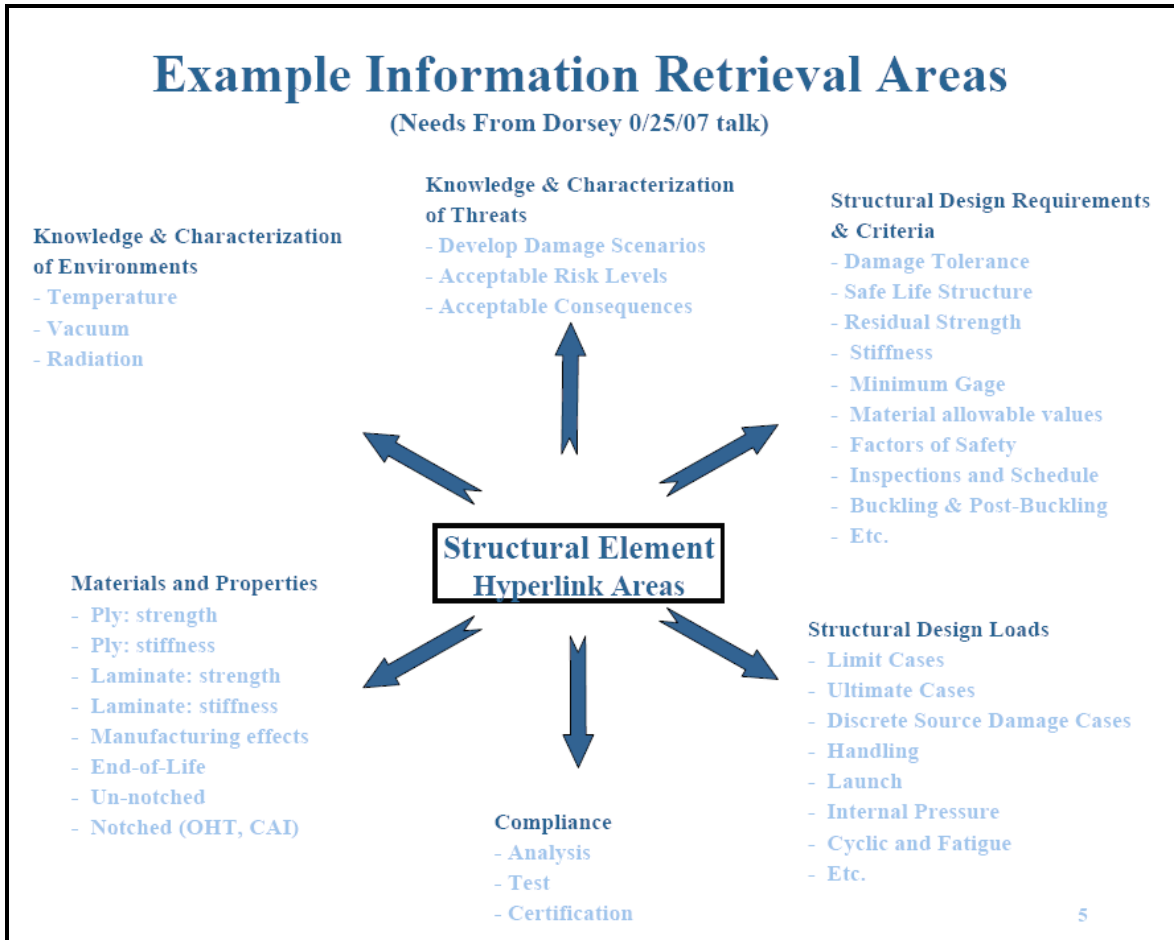


Figure 70 – Example Information Retrieval System

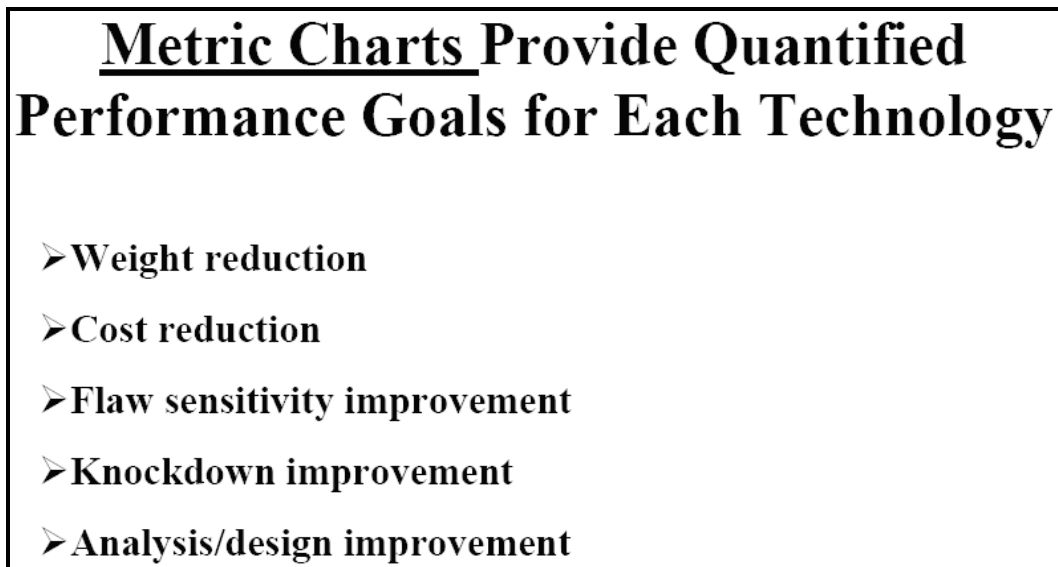
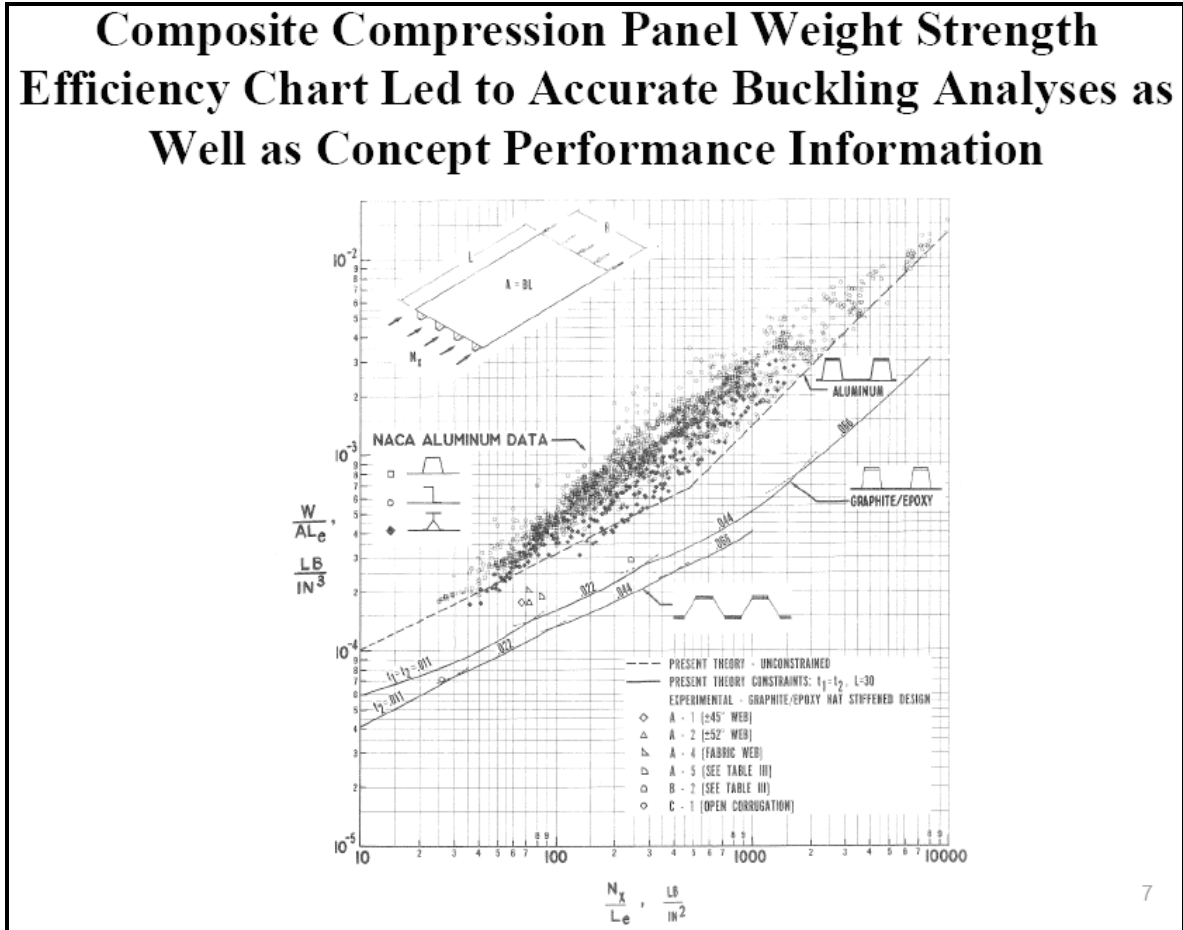


Figure 71 – Metric Charts Provide Quantified Performance Goals for Each Technology



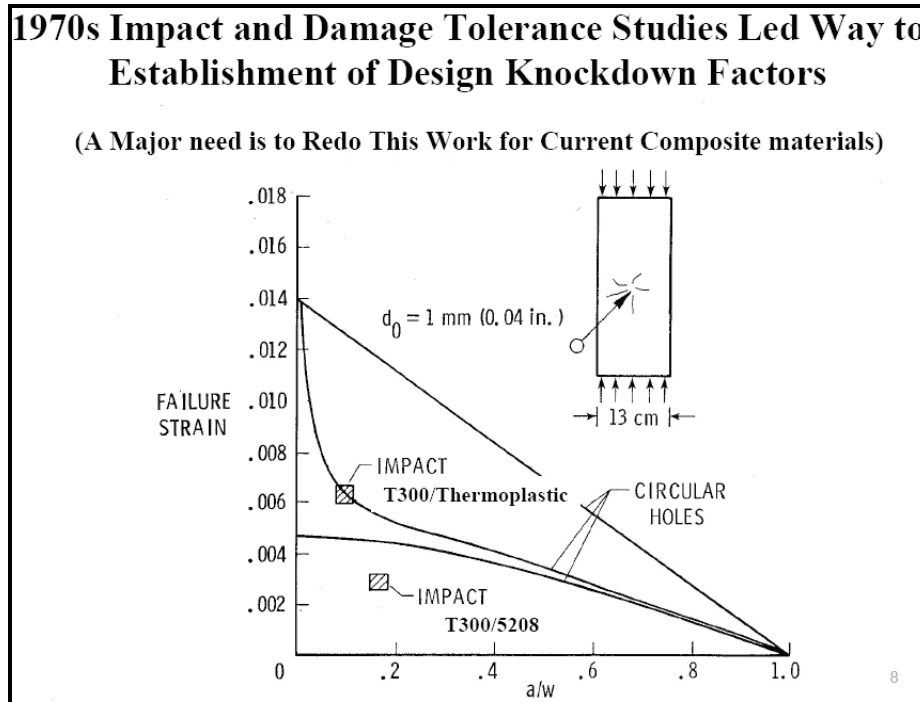
**Figure 72 – Composite Compression Panel Weight Strength Efficiency Chart Led to Accurate Buckling Analyses as Well as Concept Performance Information**

**c. Metric Charts**

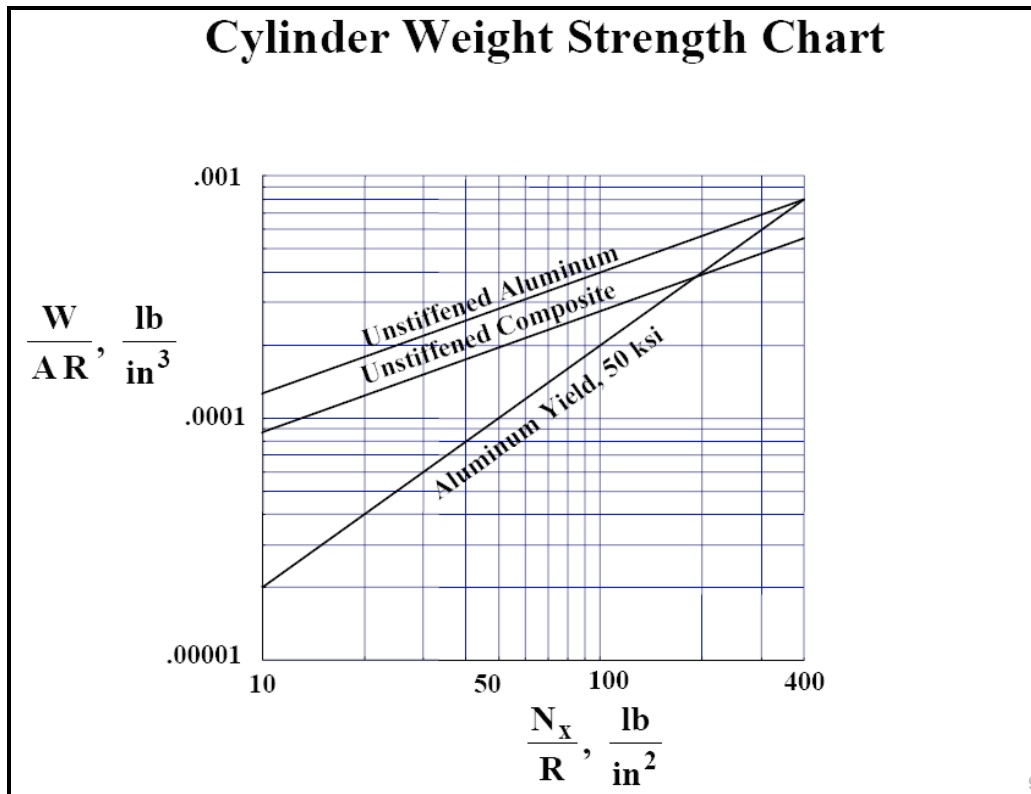
Examples of metric charts for various areas are shown in Figure 71. The type of information to be quantified will vary for different technology areas. The weight strength chart for compression panels from reference 1 is shown in Figure 72. This chart was used to guide the development of advanced composite panels, and was also used to selectively identify test articles for validation of the technology. In Figures 73 through 81, a set of largely self explanatory metric charts are presented as examples. In Figure 73 the residual strength of a T300/5208 composite panel after impact is shown. A major current need is to establish such residual strength data for new composite systems such as IM7/977-2. The availability of such data would provide accurate strength knockdown factors and maximize the potential mass savings from composites.

In Figures 74 and 75 a weight strength chart for compression cylinders are presented. Some data is plotted on the chart in Figure 71 to demonstrate the relative efficiency of various cylinder concepts. Such a chart could be used to ensure that future tests such as those being proposed by Nemeth and Hilburger are conducted on cylinders of high efficiency to ensure the value of the results. Such a chart was first presented by in reference 7 by Agarwal in 1977. A weight strength chart for space columns was developed in reference 8 and is shown in Figure 77. In Figure 78, a number of available deployable space beams are shown. A metric chart that shows the relative performance of these beams is shown in Figure 79. The parameters and curves in this Figure were derived from first principles in reference 9. In that study detailed data was collected for all

available space beams and the results are shown in Figure 80. Such data provides valuable insight into the characteristics of these beams and aids in beam design for new applications.



**Figure 73 – 1970’s Impact and Damage Tolerance Studies Led Way to Establishment of Design Knockdown Factors**



**Figure 74 – Cylinder Weight Strength Chart**

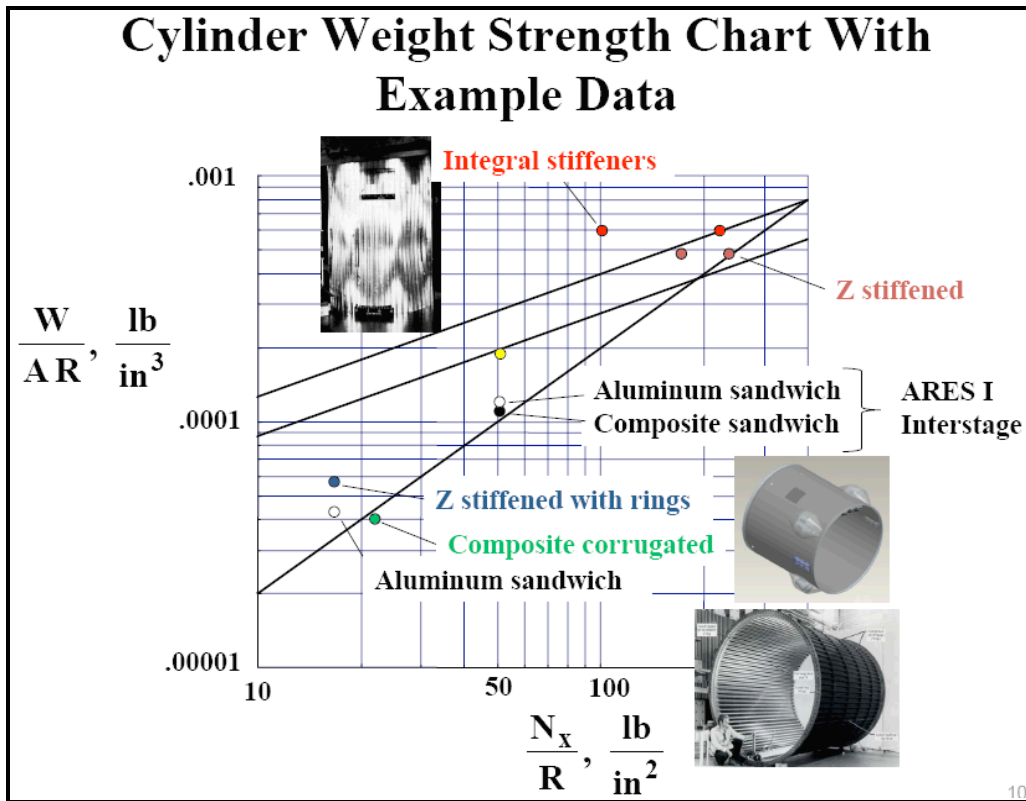


Figure 75 – Cylinder Weight Strength With Example Data

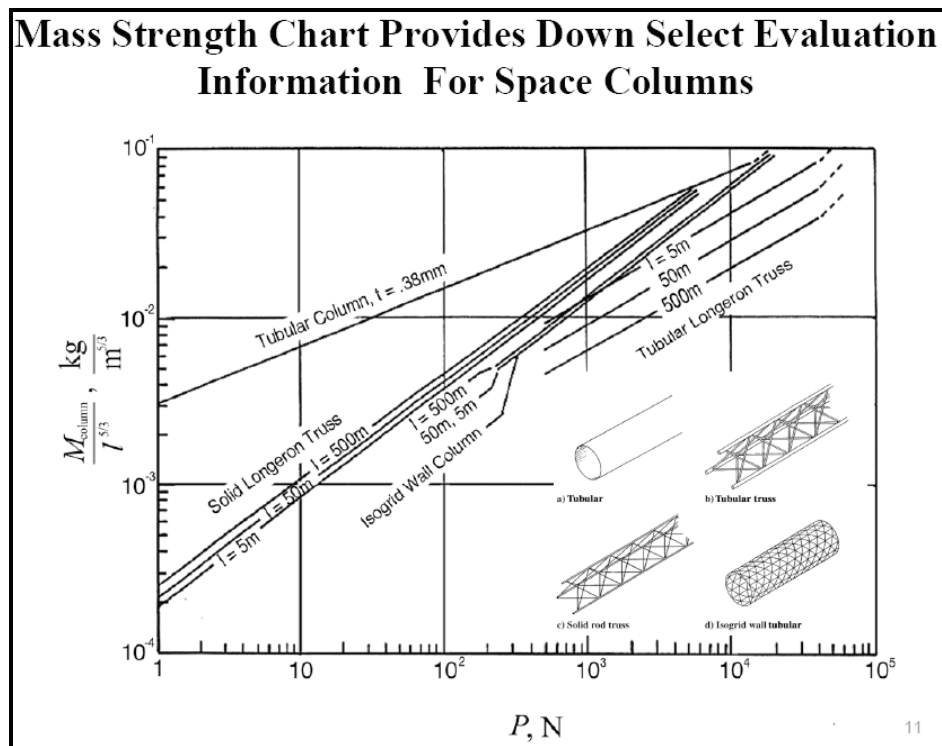
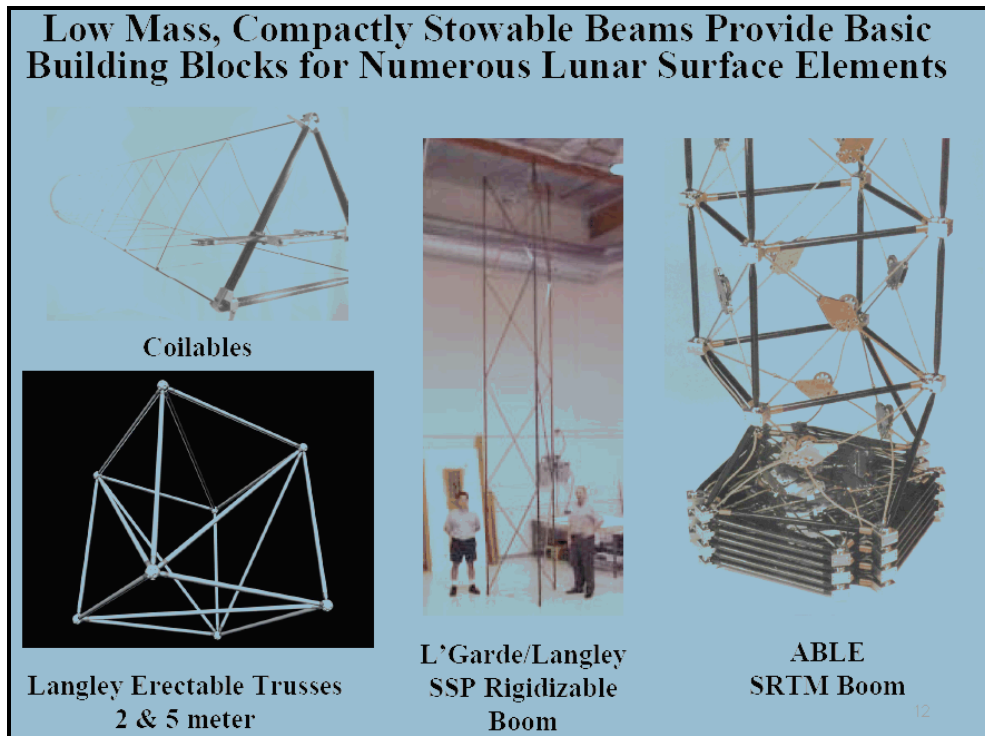
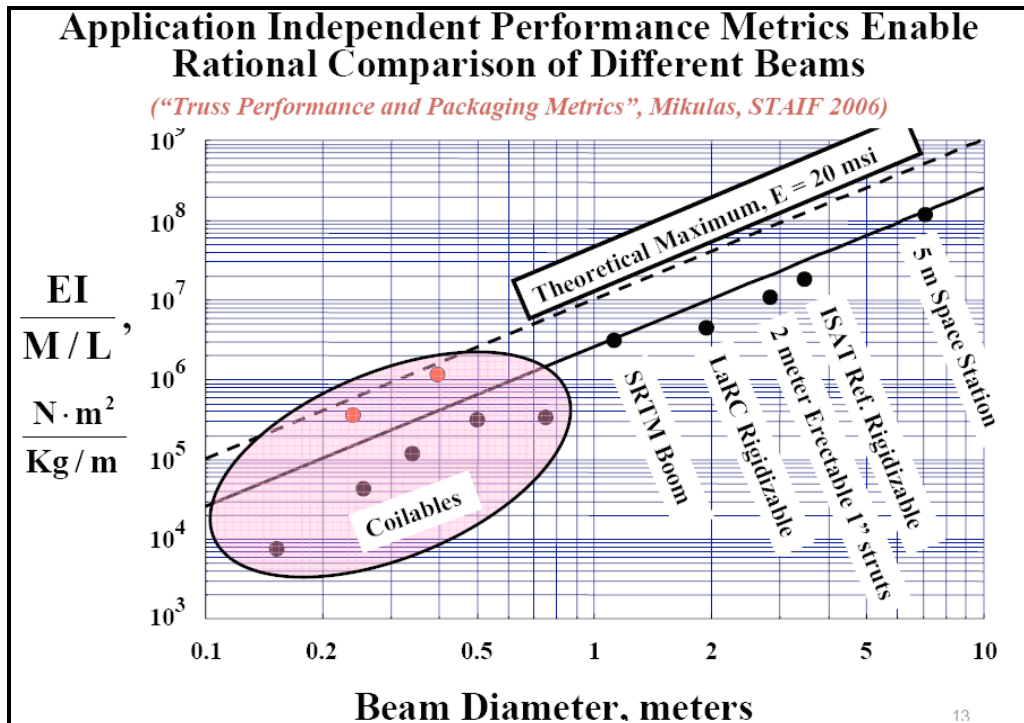


Figure 76 – Mass Strength Chart Provides Down Select Evaluation Information For Space Columns



**Figure 77 – Low Mass, Compactly Stowable Beams Provide Basic Building Blocks for Numerous Lunar Surface Elements**



**Figure 78 – Application Independent Performance Metrics Enable Rational Comparison of Different Beams**

## Space Beam Data Used in Previous Figure is an Example of Documentation Needed for Various Structures

TABLE 1.

	Fiber Glass Coilable ABLE	Gr/Ep Coilable ABLE	Isogrid ILC	SRIM ABLE	SSP Rigidizable L'Garde	ISAT Reference Rigidizable Langley	2m Erectable Langley	Space Station. 5m Erectable Langley
E (GPa)	51.7	188	153.7	165.5	65.8	41.34	137.8 (20E6 psi)	186
$\rho$ (kg/m <sup>3</sup> )	2020	1660	1660	1660	1660	1660	1660	1800
Diameter (m)	0.394	0.394	0.191	1.12	1.36	3.46	2.83	7.07
EI (Nm <sup>2</sup> )	0.01E7	0.008E7	0.0002E7	1.58E7	0.154E7	13.5E7	6.64E7	69.6E7
m (kg/m)	0.39	0.07	.07	5.23	0.7	7.3	6	9.99
Lp/Ld	0.017	0.0088	NA	0.023	---	---	NA	NA
Mom. (Nm)	270	48.6	63.6	6500	867	5280	13,000	88,000
Number of longerons	3	3	16	4	3	3	4	4
Longeron diameter (m)	See below	See below	See below	0.0157	0.035	0.152	0.0254	0.0508
Longeron thickness (mm)	5.92x6.2 rect.	2.79x2.9 rect.	.8x.99 rect.	Solid round	0.305	1.52	1.52	2.3
Longeron Length (m)	0.23	0.23	0.065	0.6975	1.709	3	2	5
Reference	Murphy 2005	Murphy 2005	Lin 2005	Umland 2001	Guidanean 2002	Mikulas Study	Collins 1989	Lake 1990

Figure 79 – Space Beam Data Used in Previous Figure is an Example of Documentation Needed for Various Structures

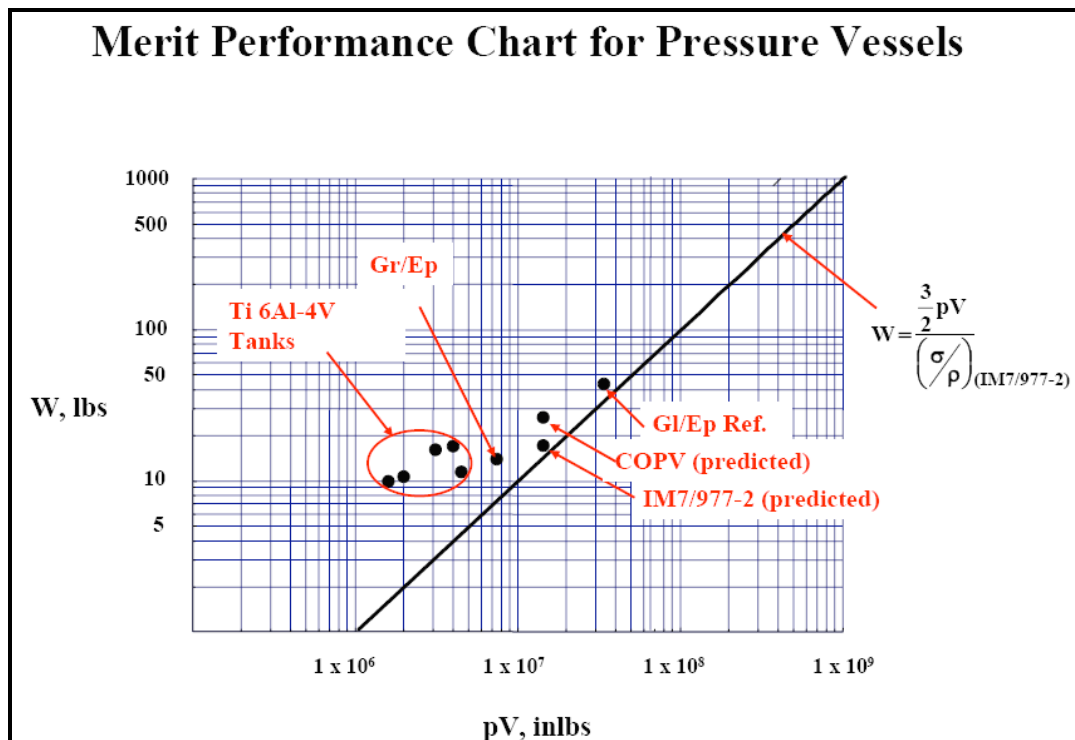
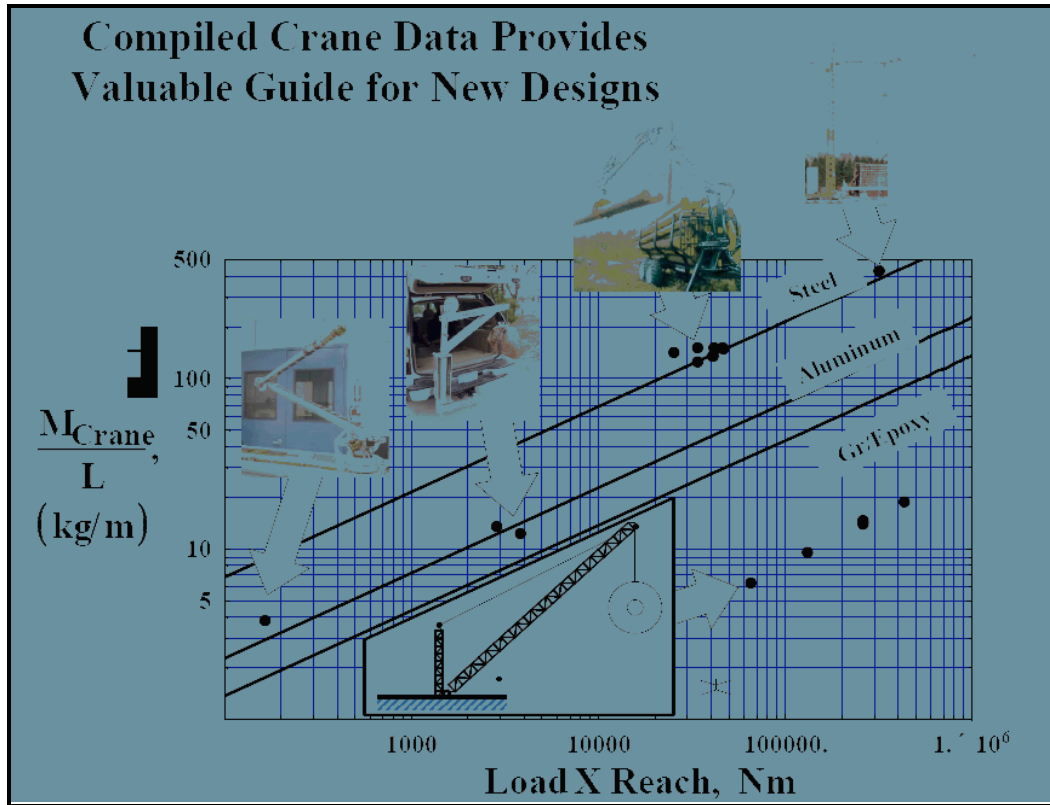


Figure 80 – Metric Performance Chart for Pressure Vessel



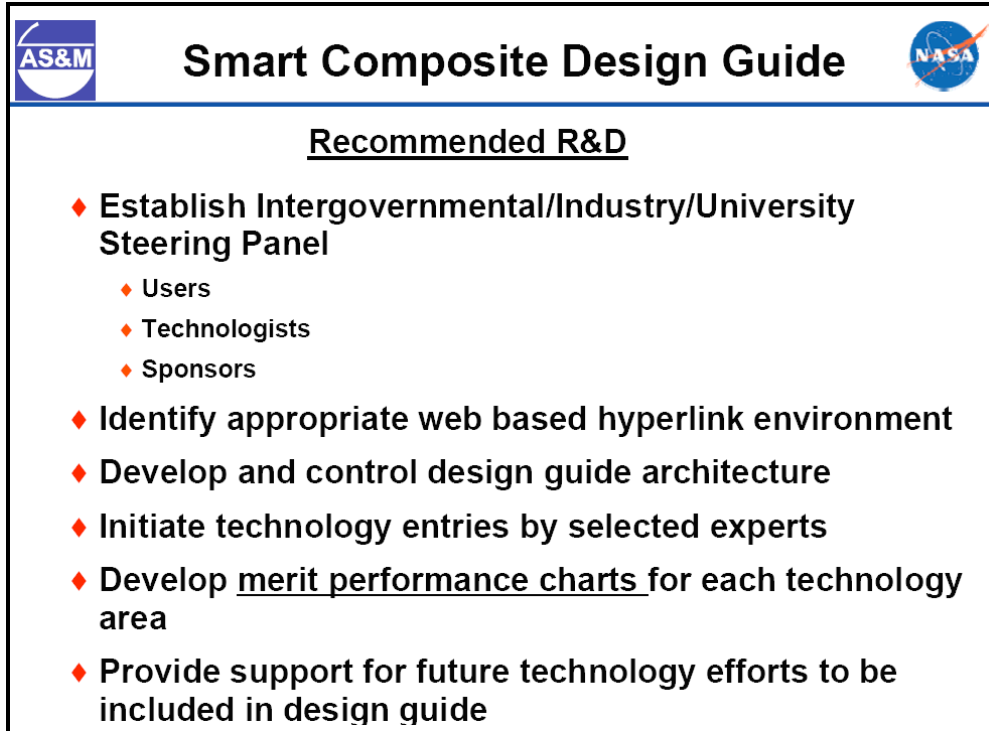
**Figure 81 – Compiled Crane Data Provides Valuable Guide for New Designs**

A weight strength performance plot for pressure vessels is presented in Figure 80 with a few data points. The weight prediction curve on the chart is from an equation presented by Schuerch in reference 10. The data was obtained and is discussed in the section on cryo tanks. A metric chart for manipulators for the Lunar surface is currently being developed at Langley Research Center. A current example of the chart is shown in Figure 81. This chart as well as the related technology is being developed to aid in system analyses of Lunar operations.

#### **d. Recommendations**

To ensure that the Smart Design Guide is user friendly and of lasting value, its development must be pursued in a systematic fashion as recommended in Figure 82. The content and architecture should continually controlled by a steering panel consisting of users, technologists and sponsors. The use of metric charts such as those presented herein, will provide a rapid understanding of the state-of-the-art of each technology and will be a valuable aid for design as well as for guiding future technology investments.





**Figure 82 – Recommended R&D for Smart Composite Design Guide**

## **e. References**

1. Williams, Jerry G. and Mikulas, Martin M., Jr., "Analytical and Experimental Study of Structurally Efficient Composite Hat-Stiffened Panels Loaded in Axial Compression," AIAA Paper No. 75-754, presented at the ASME/AIAA/SAE 16th Structures, Structural Dynamics, and Materials Conference at Denver, Colorado, May 27-29, 1975.
2. Mikulas, Martin M., Jr., Bush, Harold G. and Rhodes, Marvin D., "Current Langley Research Center Studies on Buckling and Low-Velocity Impact of Composite Panels," NASA TM X-3377, April 1976.
3. Mikulas, Martin M., Jr., "Failure Prediction Techniques for Compression Loaded Composite Laminates with Holes," NASA CP-2142, August 1980.
4. Rhodes, Marvin D., Mikulas, Martin M., Jr. and McGowan, Paul E., "Effect of Orthotropic Properties and Panel Width on the Compression Strength of Graphite-Epoxy Laminates with Holes," AIAA Paper No. 82-0749, May 1982.
5. Nemeth, Michael, and Starnes, James, "The NASA Monographs on Shell Stability Design Recommendations. A Review and Suggested Improvements", NASA/TP-1998-206290, January, 1998
6. Hilburger, Mark, Nemeth, Michael, and Starnes, James, "Shell Buckling Design Criteria Based on Manufacturing Imperfection Signatures", AIAA JOURNAL, Vol. 44, No. 3, March 2006.
7. B. L. Agarwal, *Northrop Corp., Hawthorne, Calif.* and L. H. Sobel, *Westinghouse Electric Corp., Madison, Pa.* Weight Comparisons of Optimized Stiffened, Unstiffened, and Sandwich Cylindrical Shells, J. Aircraft Vol. 14, No. 10, October, 1977.

8. Mikulas, Martin M., Jr., "Structural Efficiency of Long Lightly Loaded Truss and Isogrid Columns for Space Applications," NASA TM 78687, July 1978.
9. Martin M. Mikulas, Timothy J. Collins, William Doggett, John Dorsey, and Judith Watson, "Truss Performance and Packaging Metrics," Paper # 036, STAIF Conference, Albuquerque, NM, February, 2006.
10. Schuerch, Hans, Burggraf, Odus, "Analytical Design for Optimum Filamentary Pressure Vessels", AIAA Journal, Vol 2, No 5, May 1964.

## **F. Concluding Remarks**

Building on nearly half of century of US investment in composite structures technology primarily for aircraft and satellites composites have matured to the point where they are viable candidate materials for reducing the weight of structural components of the Constellation Program. They will result in critically needed mass savings along with associated reductions in mission costs. To achieve these benefits, however, a sustained balanced composite technology program is needed.

In this study weight predictions were made for: 1. Ares I Upper Stage (US) liquid hydrogen and liquid oxygen tanks, Ares V Earth Departure Stage (EDS) and Core Stage (CS) liquid hydrogen tanks, 2. Ares I Interstage Cylindrical Shell, 3. Lunar Surface Access Module (LSAM), Ascent Module liquid methane tank, and 4. Lunar Surface Manipulator. Advanced composites offer the potential to reduce structural weight by 20 to 40 percent in numerous elements of the Constellation Program. One of the Lunar Surface Manipulators offers an order of magnitude reduction in weight compared to current State of the Art.

A key part of this study was the evaluation of 88 different composite technologies to establish their criticality to applications for the Constellation Program. Each of the technologies was ranked for: (1) level of technology development required, (2) degree of importance, and (3) degree of difficulty to mature the technology in time to impact the Constellation Program. Based on this assessment the top rated technologies and recommended R&D for each follows.

### **1. Toughened Low Permeability Microcrack Resistant Resin Composites for Cryotanks**

(resin screening and development to optimize properties for space structures applications, establish minimum gage for damage tolerance, light weight liners)

**2. Non Autoclave Cure Processes or New Larger Autoclaves for Ares V Cryotanks** (achieve autoclave quality consolidation with thermoset and/or thermoplastic resin composites for structures 33 feet in diameter or larger)

**3. NDE Inspection Methodologies for Inspection of Complex Built-up Structural Elements** (high fidelity standards to establish minimum detectable defects/damage in composite laminates, honeycomb sandwich, joints, load transfer points)

**4. Structural Health Monitoring** (an integrated suite of sensors and instrumentation to assess long service life)

**5. Adhesive Bonding for Extreme Temperature Environments** (conduct a broad assessment survey of adhesives used to bond composite structures)

**6. Low Mass Structural Concepts for Lunar Surface Systems** (cranes, rovers, habitats, deployable, inflatable, expandable, rigidizable, high specific modulus composites, minimum gage for ultra light structure)

**7. High Fidelity Structural Analysis** (first principle micromechanics constituent modeling to obtain better methods for predicting the on set of fracture and subsequent growth to critical levels, an open fracture data base for IM7/977-2, composite fracture monograph to evaluated new materials and guide future development, data on composite cylinders and weight strength charts to benchmark current status and to guide future development of efficient composite cylinders and a shell stability monographs to aide future designers and engineers)

**8. Rapid Conceptual Design Methodology** (an intelligent decision aide search capability to codify all controlling documents for Constellation elements to allow technologists to quickly determine the pertinent design requirements, desktop codes capable of predicting loads, environments, failure modes, failure loads, and minimum weight concepts, codes such that changes in materials and structural concepts, analysis methods, knockdown factors, influence on size of anomaly detectable and health monitoring are easy to make and the change in weight savings predicted)

**9. Smart Space Composites Design Guide for Space Structures** ( user friendly lasting value, developed in a systematic fashion, content and architecture continually controlled by a steering panel of users, technologists and sponsors, metric charts such for rapid understanding of the state-of-the-art of each technology, and a valuable aid for design as well as for guiding future technology investments)

**The overall outcome of this study shows that composites are viable structural materials which offer from 20% to 40% weight savings for many of the structural components that make up the Major Elements of the Constellation Program. NASA investment in advancing composite technologies for space structural applications is an investment in America's Space Exploration Program. To ensure that the Constellation Program builds on the success of past program such as the Apollo program advancements in critical enabling technologies must be an integral part of NASA's investment strategy.**

## **G. Appendices**

- A.1 Structural Elements and Leading Concepts for Composite Applications to the Constellation Program
- A.2 Composite Technologies Evaluated and Technology Assessment Process
- A.3 Example Technology Assessment Spreadsheets for Ares I Upper Stage Cryotank
- A.4 Lightweight Composite Propellant Tanks for Lunar Surface Access Module (LSAM) Storyboard

These Appendices are included in a separate PDF file which was provided electronically to the NASA Contracting Officer Technical Representative (COTR).

# **Appendices for AS&M Final Report** **NASA Contract NNL04AA10B**

All of the Appendices developed under NASA Contract NNL04AA10B, Task Order NNL07AD55T entitled “Evaluation of Advanced Composite Structures Technologies for Application to NASA’s Vision for Space Exploration” are included in this Section.

**Appendix A.1 - Structural Elements and Leading Concepts for Composite Applications to the Constellation Program----- Page 2**

**Appendix A.2 – Composite Technologies Evaluated and Technology Assessment Process----- Page 34**

**Appendix A.3 – Example Technology Assessment Spreadsheets for Ares I Upper Stage Cryotank, Common Bulk Head Tank Concept, Sandwich Structural Concept----- Page 40**

**Appendix A.4 - Lightweight Composite Propellant Tanks for Lunar Surface Access Module (LSAM) Storyboard----- Page 64**

# Appendix A.1

## Structural Elements and Leading Structural Concepts for Composite Applications to the Constellation Program

The Major Factors used to Identify High Payoff Structural Elements and Leading Concepts for Composite Applications to the Constellation Program included:

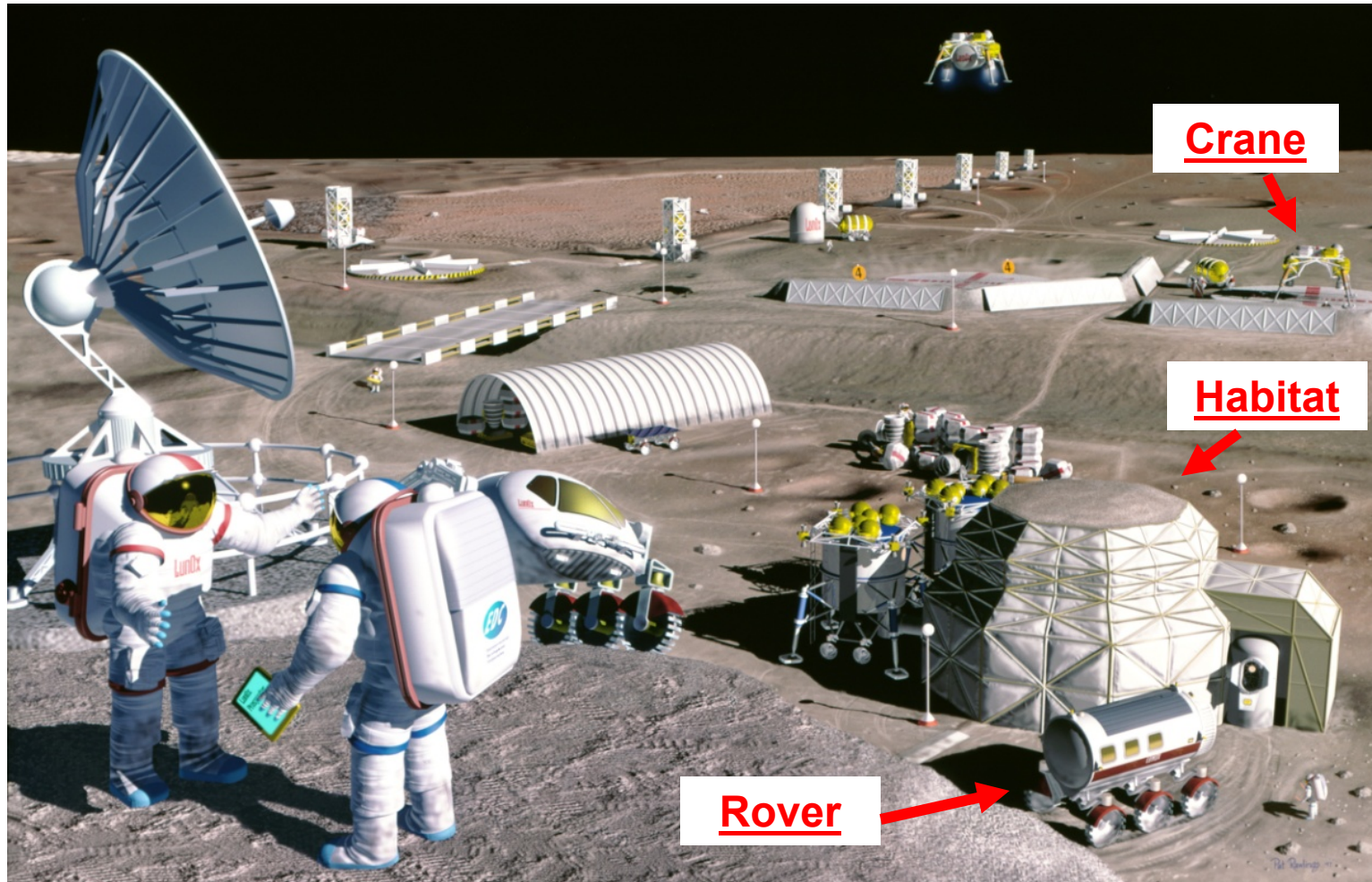
1. Applications where high values of  $\sigma/\rho$ ,  $E^{1/2}/\rho$ ,  $E^{1/3}/\rho$  would be most beneficial to minimize weight
2. Efficient fabrication of lightweight simple or compound curvature components could be achieved in reasonable time frame
3. Broad area applications were likely
4. Concepts where benefits of composites have been demonstrated in past applications
5. Primary structural components where benefits could be quantified

# Constellation Program Elements and Structural Elements for Composite Applications

<u>Constellation Element</u>	<u>Structural Element</u>
<b>1 Lunar Surface Elements</b> <b>1A Habitats</b> <b>1B Rovers</b> <b>1C Cranes</b>	<b>1Aa Deployable, 1Ab Hybrid - Shell/Deployable, 1Ac Rigid Shells</b> <b>1Ba Body, 1Bb Frame</b> <b>1Ca Boom, 1Cb Joints, 1Cc Mechanisms</b>
<b>2 Lunar Surface Access Module (LSAM)</b> <b>2A Descent Stage</b> <b>2B Ascent Stage</b>	<b>2Aa Crew Module, 2Ab Propellant Tanks, 2Ac Frame</b> <b>2Ba Crew Module, 2Bb Propellant Tanks, 2Bc Frame</b>
<b>3 Ares I</b> <b>3A First Stage</b> <b>3B Interstage</b> <b>3C Upper stage</b> <b>3D CEV</b>	<b>3Aa Forward Adapter, 3Ab RSRB Case</b> <b>3Ba Shell</b> <b>3Ca LOX/LH<sub>2</sub> Tanks, 3Cb Thrust Structure, 3Cc Skirts/Shells</b> (See Orion CEV Breakout Below)
<b>4 Orion Crew Exploration Vehicle</b> <b>4A Space Craft Adapter</b> <b>4B Crew module</b> <b>4C Service Module</b> <b>4D Launch Abort System</b>	<b>4Aa Shell</b> <b>4Ba High q,G,T Pressure Vessel (Crew Module)</b> <b>4Ca LOX/LH<sub>2</sub> Tanks, 4Cb Thrust Structure, 4Cc Skirts/Shells</b> <b>4Da Adapter Cone, 4Db Interstage, 4Dc Shroud, 4Dd Canards</b>
<b>5 Ares V</b> <b>5A Core Stage</b> <b>5B Interstage</b> <b>5C Earth Departure Stage</b> <b>5D RSRB</b> <b>5E LSAM</b>	<b>5Aa Fwd. Adapter, 5Ab LOX/LH<sub>2</sub> Tanks, 5Ac Intertank, 5Ad Thrust Str.</b> <b>5Ba Shell, 5Bb Skirt</b> <b>5Ca LOX/LH<sub>2</sub> Tanks, 5Cb Thrust Structure, 5Cc Skirts/Shells</b> <b>5Da Propellant Case</b> <b>5E (See LSAM Breakout Above)</b>



# 1 Lunar Surface Elements



# 1 Lunar Surface Elements

## Potential Composite Applications

### 1A Habitats

<u>Structural Element</u>	<u>Structural Concepts</u>	<u>% Payoff vs. Baseline</u> (Wt., Cost, etc.)
<b>1Aa</b> Deployable	<ul style="list-style-type: none"> <li>• <b>1Aa1</b> Inflatable</li> <li>• <b>1Aa2</b> Inflate/Rigidize</li> </ul>	•
<b>1Ab</b> Hybrid-Shell/Deployable	<ul style="list-style-type: none"> <li>• <b>1Ab1</b> Stiffened Rigid Shells/Deployable Sections</li> </ul>	•
<b>1Ac</b> Rigid Shells	<ul style="list-style-type: none"> <li>• <b>1Ac1</b> Stiffened</li> <li>• <b>1Ac2</b> Sandwich</li> </ul>	• •

# 1 Lunar Surface Elements

## Potential Composite Applications

### 1B Rovers

<u>Structural Element</u>	<u>Structural Concepts</u>	<u>% Payoff vs. Baseline</u> (Wt., Cost, etc.)
<b>1Ba Body</b>	<ul style="list-style-type: none"> <li>• <b>1Ba1 Rigidizable-Inflatable Pressurized Shell</b></li> <li>• <b>1Ba2 Stiffened Shell</b></li> <li>• <b>1Ba3 Open Frame</b></li> </ul>	<ul style="list-style-type: none"> <li>•</li> <li>•</li> <li>•</li> </ul>
<b>1Bb Frame</b>	<ul style="list-style-type: none"> <li>• <b>1Bb1 Truss</b></li> <li>• <b>1Bb2 Beams</b></li> </ul>	<ul style="list-style-type: none"> <li>•</li> </ul>

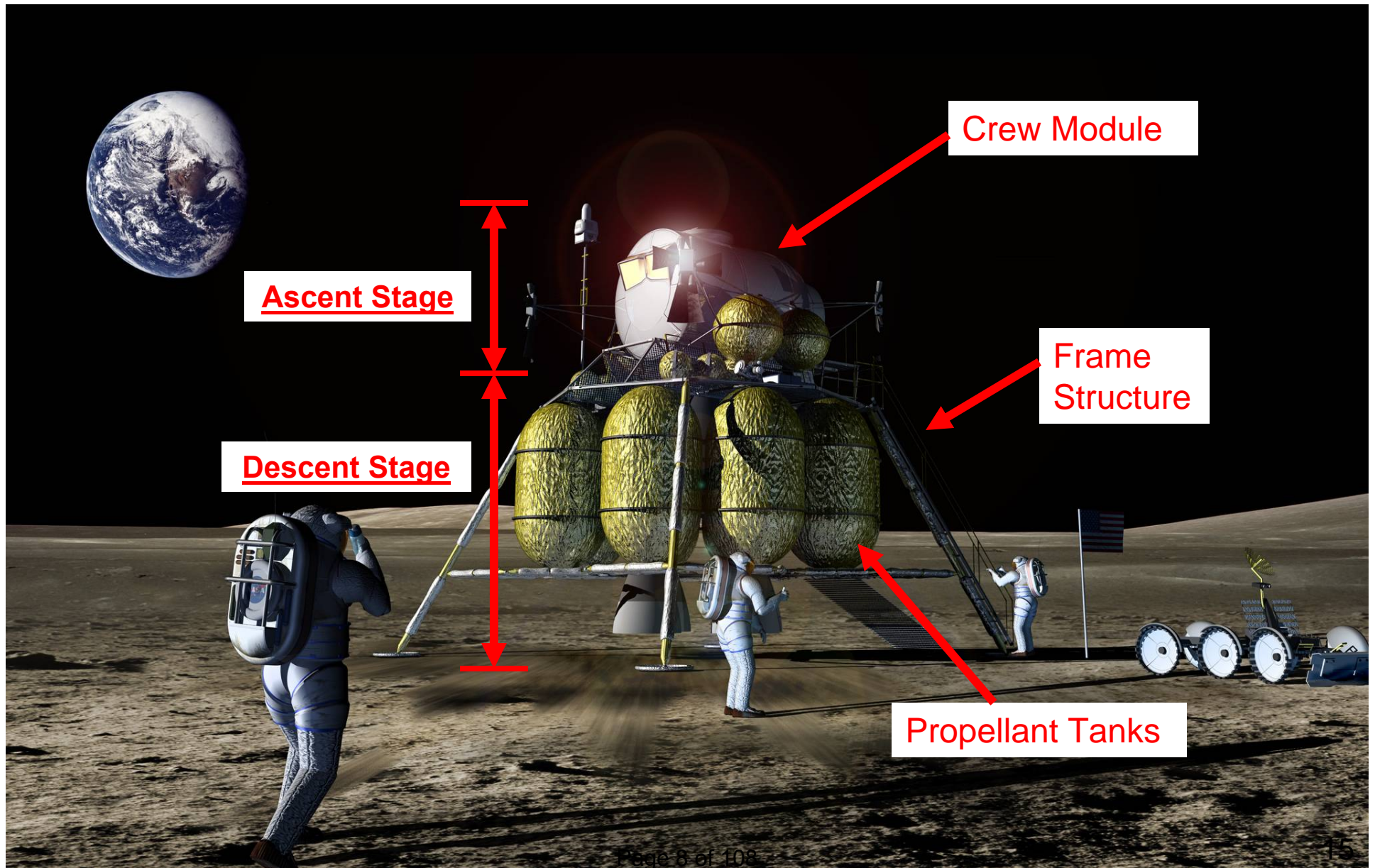
# 1 Lunar Surface Elements

## Potential Composite Applications

### 1C Cranes

<u>Structural Element</u>	<u>Structural Concepts</u>	<u>% Payoff vs. Baseline</u> (Wt., Cost, etc.)
<b>1Ca Boom</b>	<ul style="list-style-type: none"> <li>• <b>1Ca1</b> Truss-Erectable</li> <li>• <b>1Ca2</b> Rigidizable-Inflatable</li> </ul>	<ul style="list-style-type: none"> <li>•</li> <li>•</li> </ul>
<b>1Cb Joints</b>	<ul style="list-style-type: none"> <li>• <b>1Cb1</b> Currently not specified</li> </ul>	<ul style="list-style-type: none"> <li>•</li> <li>•</li> </ul>
<b>1Cc Mechanisms</b>	<ul style="list-style-type: none"> <li>• <b>1Cc1</b> Currently not specified</li> </ul>	<ul style="list-style-type: none"> <li>•</li> </ul>

## 2 Lunar Surface Access Module (LSAM) Constellation Program



# 2 Lunar Surface Access Module Potential Composite Applications

## 2A Descent Stage

Same for Ascent

<u>Structural Element</u>	<u>Structural Concepts</u>	<u>% Payoff vs. Baseline</u> (Wt., Cost, etc.)
<b>2Aa Crew Module</b>	<ul style="list-style-type: none"> <li>• <b>2Aa1</b> Sandwich</li> <li>• <b>2Aa2</b> Grid Stiffened</li> <li>• <b>2Aa3</b> Monolithic</li> </ul>	<ul style="list-style-type: none"> <li>•</li> <li>•</li> <li>•</li> </ul>
<b>2Ab Propellant Tanks</b>	<ul style="list-style-type: none"> <li>• <b>2Ab1</b> COPV</li> <li>• <b>2Ab2</b> Grid Stiffened</li> <li>• <b>2Ab3</b> No Metal Liner Composite</li> </ul>	<ul style="list-style-type: none"> <li>•</li> <li>•</li> </ul>
<b>2Ac Frame Structure</b>	<ul style="list-style-type: none"> <li>• <b>2Ac1</b> Truss – Comp./Metal Joints</li> <li>• <b>2Ac2</b> Hybrid Truss</li> </ul>	<ul style="list-style-type: none"> <li>•</li> </ul>

**2Ab** Propellant Tanks

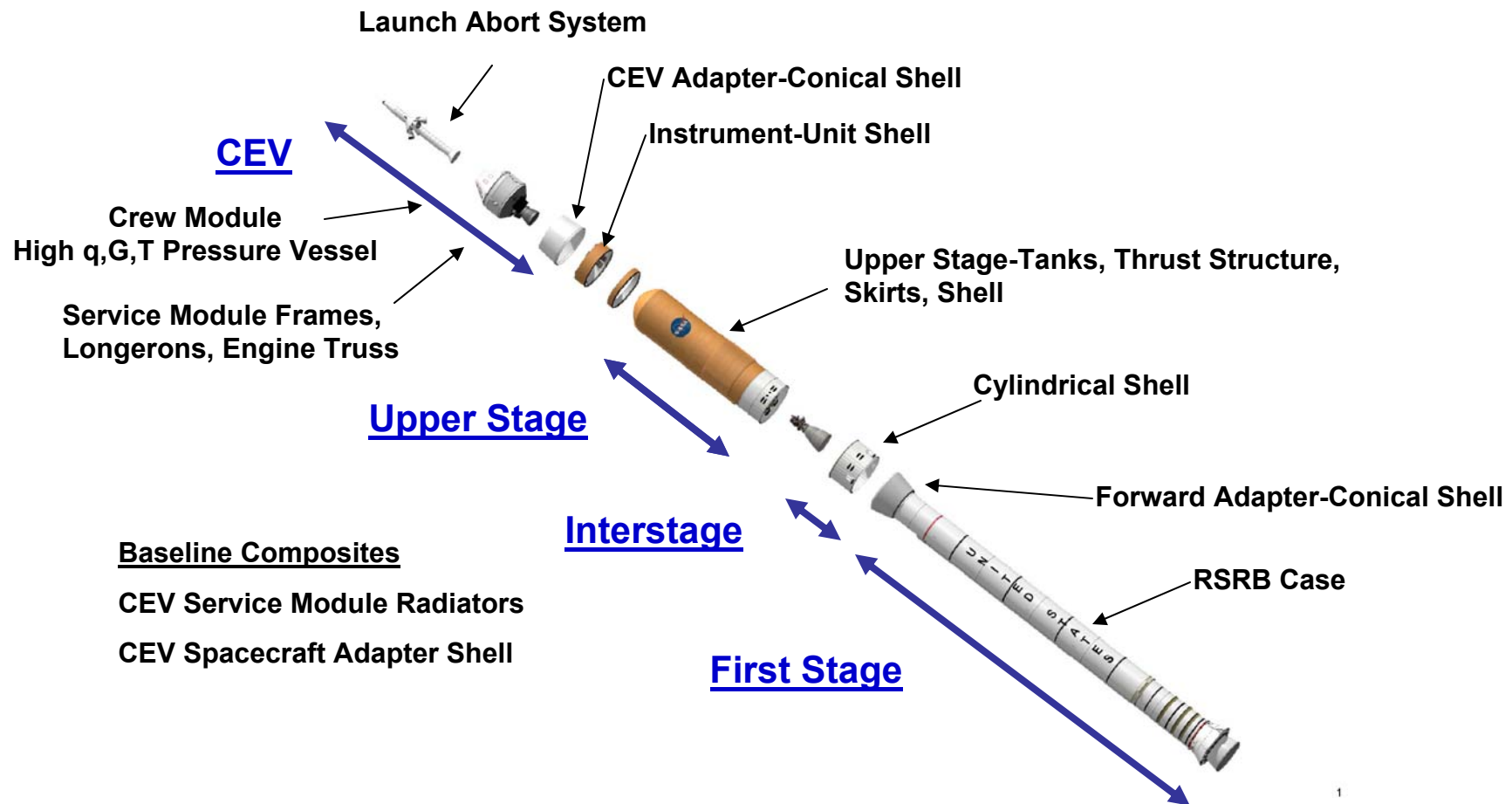
# 2 Lunar Surface Access Module Potential Composite Applications

## **2B Ascent Stage**

*Same for Descent*

<b><u>Structural Element</u></b>	<b><u>Structural Concepts</u></b>	<b><u>% Payoff vs. Baseline</u></b> (Wt., Cost, etc.)
<b>2Ba Crew Module</b>	<ul style="list-style-type: none"> <li>• <b>2Ba1</b> Sandwich</li> <li>• <b>2Ba2</b> Grid Stiffened</li> <li>• <b>2Ba3</b> Monolithic</li> </ul>	<ul style="list-style-type: none"> <li>•</li> <li>•</li> <li>•</li> </ul>
<b>2Bb Propellant Tanks</b>	<ul style="list-style-type: none"> <li>• <b>2Bb1</b> COPV</li> <li>• <b>2Bb2</b> Grid Stiffened</li> <li>• <b>2Bb3</b> No Metal Liner Composite</li> </ul>	<ul style="list-style-type: none"> <li>•</li> <li>•</li> <li>•</li> </ul>
<b>2Bc Frame Structure</b>	<ul style="list-style-type: none"> <li>• <b>2Bc1</b> Truss – Comp./Metal Joints</li> <li>• <b>2Bc2</b> Hybrid Truss</li> </ul>	<ul style="list-style-type: none"> <li>•</li> <li>•</li> </ul>

# 3 Ares I Crew Launch Vehicle Potential Composite Applications





# 3 Ares I Crew Launch Vehicle Potential Composite Applications

## 3A First Stage

<u>Structural Element</u>	<u>Structural Concepts</u>	<u>% Payoff vs. Baseline</u> (Wt., Cost, etc.)
<b>3Aa</b> Forward Adapter	<ul style="list-style-type: none"> <li>• <b>3Aa1</b> Stiffened Shell</li> <li>• <b>3Aa2</b> Sandwich Shell</li> </ul>	<ul style="list-style-type: none"> <li>•</li> <li>•</li> </ul>
<b>3Ab</b> RSRB Case	<ul style="list-style-type: none"> <li>• <b>3Ab1</b> Composite Cylinders / Metal Joints</li> </ul>	<ul style="list-style-type: none"> <li>•</li> </ul>

# 3 Ares I Crew Launch Vehicle Potential Composite Applications

## 3B Interstage

<u>Structural Element</u>	<u>Structural Concepts</u>	<u>% Payoff vs. Baseline</u> (Wt., Cost, etc.)
<b>3Ba Shell</b>	<ul style="list-style-type: none"><li>• <b>3Ba1</b> Sandwich – w/wo stiffeners</li><li>• <b>3Ba2</b> Monolithic with stiffeners</li></ul>	<ul style="list-style-type: none"><li>•</li><li>•</li></ul>

# 3 Ares I Crew Launch Vehicle Potential Composite Applications

## 3C Upper Stage

<u>Structural Element</u>	<u>Structural Concepts</u>	<u>% Payoff vs. Baseline</u> (Wt., Cost, etc.)
<b>3Ca</b> LOX/LH <sub>2</sub> Tanks	<ul style="list-style-type: none"> <li>• <b>3Ca1</b> Sandwich</li> <li>• <b>3Ca2</b> Grid Stiffened</li> <li>• <b>3Ca3</b> Monolithic</li> </ul>	<ul style="list-style-type: none"> <li>•</li> <li>•</li> <li>•</li> </ul>
<b>3Cb</b> Thrust Structure	<ul style="list-style-type: none"> <li>• <b>3Cb1</b> Truss - Comp/Metal joints</li> <li>• <b>3Cb2</b> Stiffened Conical Shell</li> </ul>	<ul style="list-style-type: none"> <li>•</li> <li>•</li> </ul>
<b>3Cc</b> Skirts/Shells	<ul style="list-style-type: none"> <li>• <b>3Cc1</b> Stiffened Cylinders</li> <li>• <b>3Cc2</b> Sandwich Cylinders</li> </ul>	<ul style="list-style-type: none"> <li>•</li> <li>•</li> </ul>

# 3 Ares I Crew Launch Vehicle Potential Composite Applications

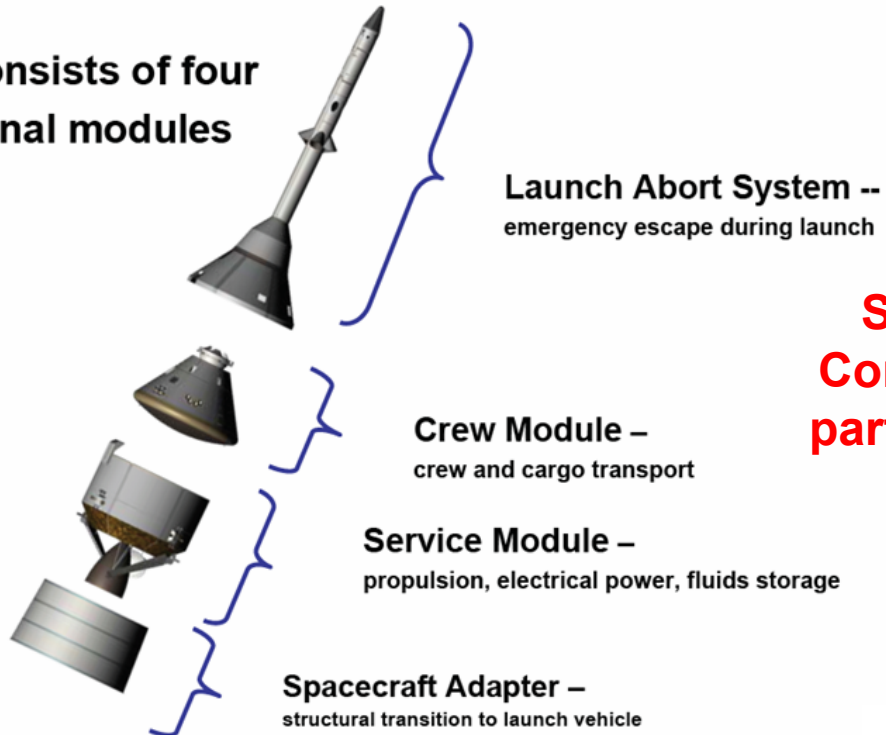
## 3D Crew Exploration Vehicle



The Lockheed Martin Orion System Elements



Orion consists of four functional modules



**Structural Elements and Concepts are not Broken as part of Ares 1 but are broken out**

# 4 Orion Crew Exploration Vehicle Potential Composite Applications

## 4A Space Craft Adapter

<u>Structural Element</u>	<u>Structural Concepts</u>	<u>% Payoff vs. Baseline</u> (Wt., Cost, etc.)
<b>4Aa Shell</b>	<ul style="list-style-type: none"><li>• <b>4Aa1</b> Sandwich – w/wo stiffeners</li><li>• <b>4Aa2</b> Monolithic with stiffeners</li></ul>	<ul style="list-style-type: none"><li>•</li><li>•</li></ul>

# 4 Orion Crew Exploration Vehicle Potential Composite Applications

## **4B Crew Module**

<u>Structural Element</u>	<u>Structural Concepts</u>	<u>% Payoff vs. Baseline</u> (Wt., Cost, etc.)
<b>4Ba</b> High q,G,T Pressure Vessel (Crew Module)	<ul style="list-style-type: none"><li>• <b>4Ba1</b> Sandwich</li><li>• <b>4Ba2</b> Grid Stiffened</li><li>• <b>4Ba3</b> Monolithic</li></ul>	<ul style="list-style-type: none"><li>•</li><li>•</li><li>•</li></ul>

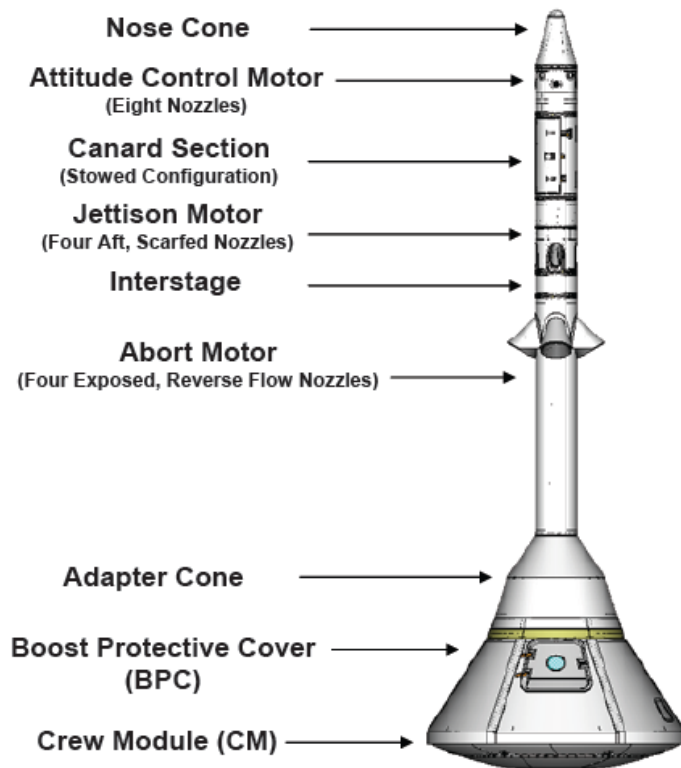
# 4 Orion Crew Exploration Vehicle Potential Composite Applications

## 4C Service Module

<u>Structural Element</u>	<u>Structural Concepts</u>	<u>% Payoff vs. Baseline</u> (Wt., Cost, etc.)
<b>4Ca</b> LOX/LH2 Tanks	<ul style="list-style-type: none"> <li>• <b>4Ca1</b> Sandwich</li> <li>• <b>4Ca2</b> Grid Stiffened</li> <li>• <b>4Ca3</b> Monolithic</li> </ul>	<ul style="list-style-type: none"> <li>•</li> <li>•</li> <li>•</li> </ul>
<b>4Cb</b> Thrust Structure	<ul style="list-style-type: none"> <li>• <b>4Cb1</b> Truss - Comp/Metal joints</li> <li>• <b>4Cb2</b> Stiffened Conical Shell</li> </ul>	<ul style="list-style-type: none"> <li>•</li> <li>•</li> </ul>
<b>4Cc</b> Skirts/Shells	<ul style="list-style-type: none"> <li>• <b>4Cc1</b> Stiffened Cylinders</li> <li>• <b>4Cc2</b> Sandwich Cylinders</li> </ul>	<ul style="list-style-type: none"> <li>•</li> <li>•</li> </ul>

# 4 Orion Crew Exploration Vehicle Potential Composite Applications

## 4D Launch Abort System



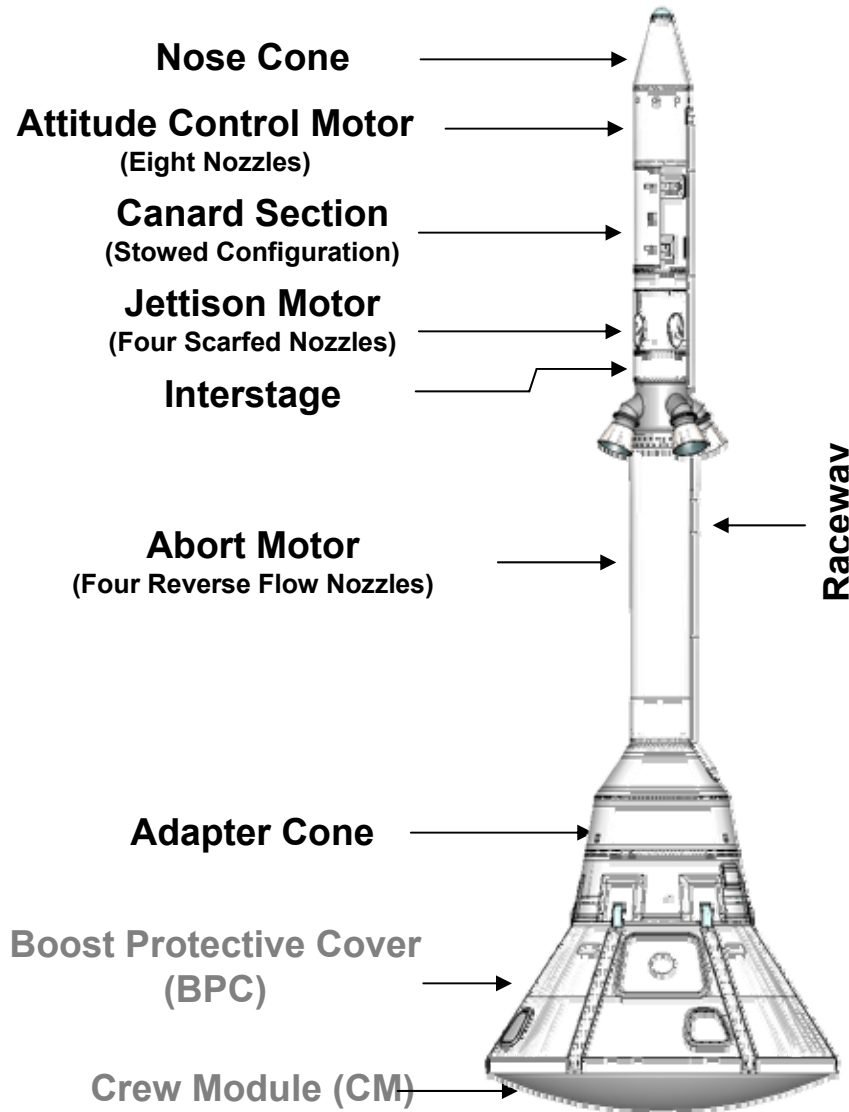
<u>Configuration Summary</u>	
<u>Abort Motor</u>	
No. of Nozzles:	4
Nozzle Cant Angle (to CL):	30°
Isp (sea level):	250s
Thrust (Total in Vehicle Axis):	506,408 lbs
Burn Time:	2.0s
T/W:	15:1
<u>Attitude Control Motor</u>	
No. of Nozzles:	8
Nozzle Cant Angle (to CL):	90°
Isp (vac):	227s
Thrust (per Nozzle):	2500 lbs
Burn Time:	20s
<u>Jettison Motor</u>	
No. of Nozzles:	4
Nozzle Cant Angle (to CL):	35°
Isp (vac.):	221s
Thrust (per Nozzle):	9668 lbs
Burn Time:	1.5 s

<u>Mass Properties Summary</u>	
Dry Mass	8148 lbs
Propellant	5468 lbs
GLOW	13616
lbs	

Launch Abort Vehicle (LAV): Crew Module + LAS

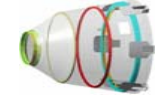


# 4D Launch Abort System



## Major Structural Subsystems

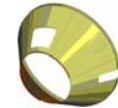
Adapter Cone Assembly



Canard Actuator



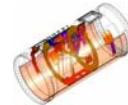
Boost Protective Cover



Canard Structure



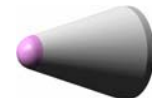
Canard Deployment Mechanism



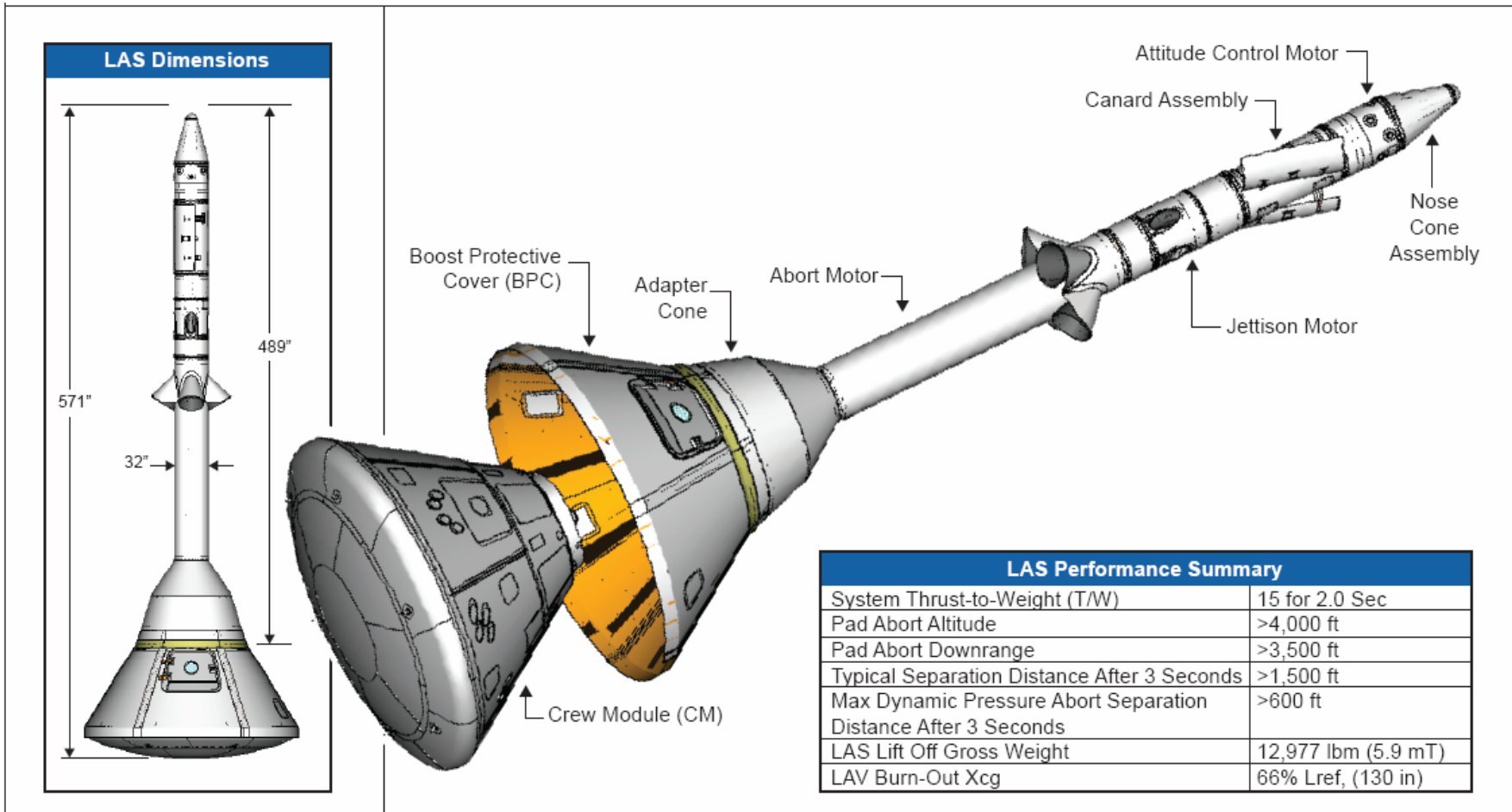
Interstage



Nose Cone Adapter



# Launch Abort System (LAS)

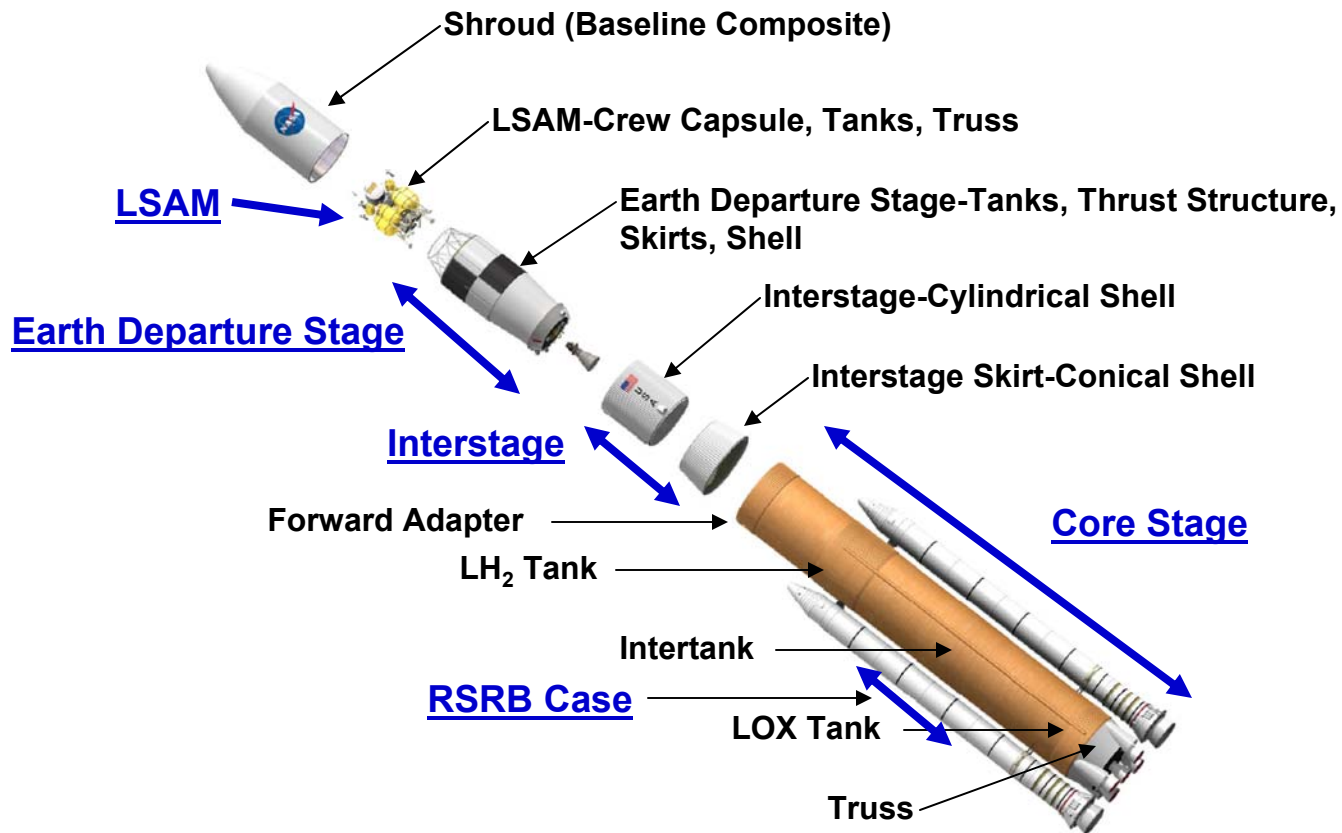


# 4 Orion Crew Exploration Vehicle Potential Composite Applications

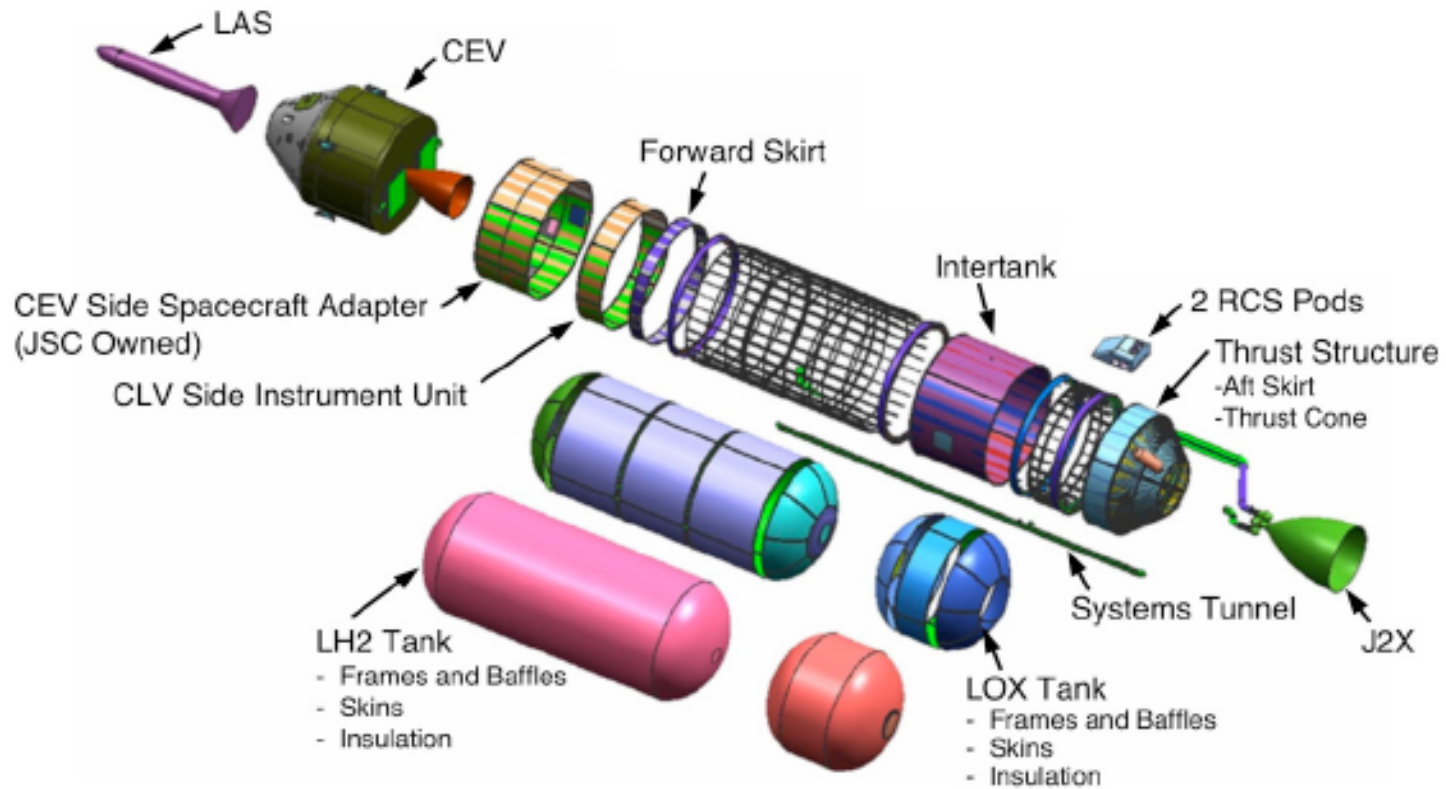
## 4D Launch Abort System

<u>Structural Element</u>	<u>Structural Concepts</u>	<u>% Payoff vs. Baseline</u> (Wt., Cost, etc.)
<b>4Da</b> Adaptor Cone	<ul style="list-style-type: none"> <li>• <b>4Da1</b> Monolithic with stiffeners</li> <li>• <b>4Da2</b> Sandwich – w/wo stiffeners</li> </ul>	<ul style="list-style-type: none"> <li>•</li> <li>•</li> <li>•</li> </ul>
<b>4Db</b> Interstage	<ul style="list-style-type: none"> <li>• <b>4Db1</b> Monolithic with stiffeners</li> <li>• <b>4Db2</b> Sandwich – w/wo stiffeners</li> </ul>	<ul style="list-style-type: none"> <li>•</li> <li>•</li> </ul>
<b>4Dc</b> Shroud	<ul style="list-style-type: none"> <li>• <b>4Dc1</b> Monolithic with stiffeners</li> <li>• <b>4Dc2</b> Sandwich – w/wo stiffeners</li> </ul>	<ul style="list-style-type: none"> <li>•</li> <li>•</li> </ul>
<b>4Dd</b> Canards	<ul style="list-style-type: none"> <li>• <b>4Dd1</b> Tape Laminate</li> <li>• <b>4Dd2</b> Stitched laminate</li> </ul>	<ul style="list-style-type: none"> <li>•</li> <li>•</li> </ul>

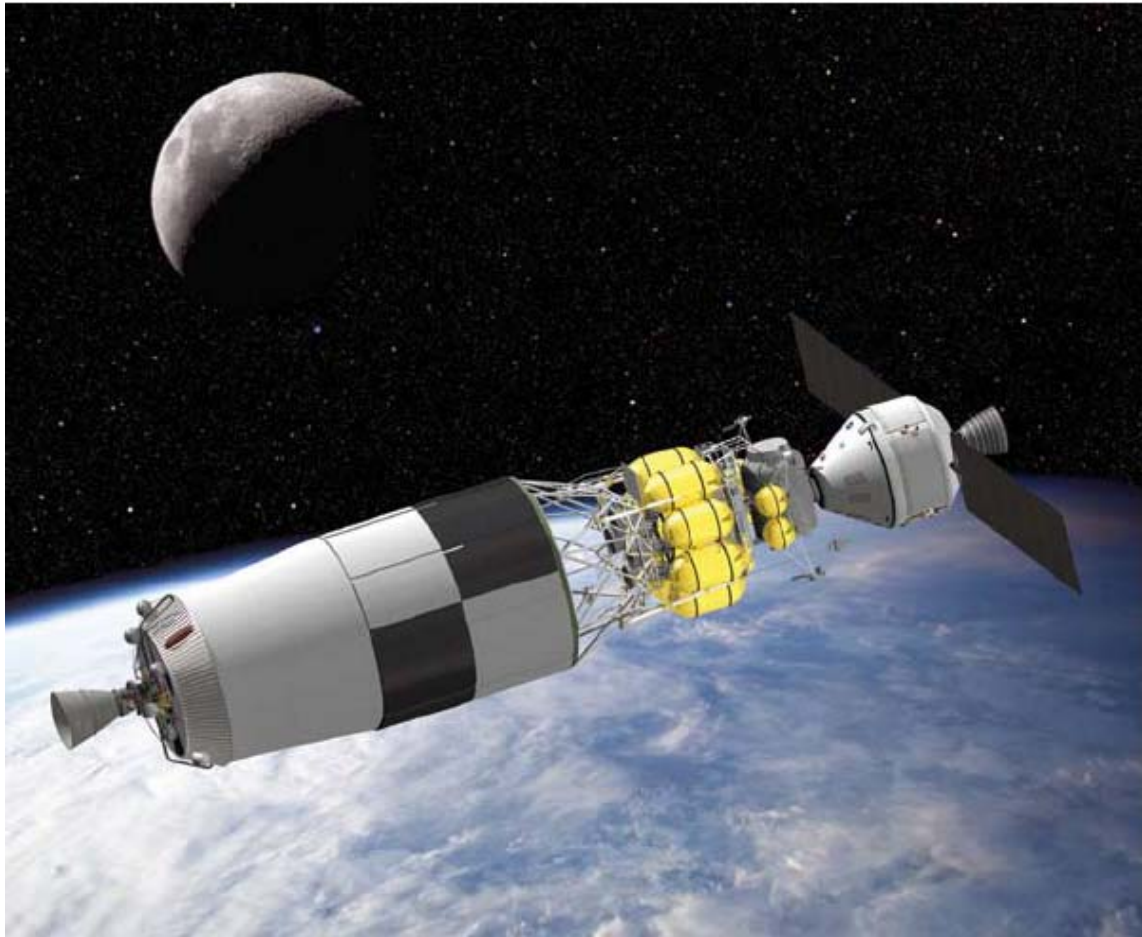
# 5 Ares V Cargo Launch Vehicle Potential Composite Applications



# Upper Stage Core Structural Elements



# Ares V Earth Departure Stage Orion Docked with the Lunar Surface Access Module



# 5 Ares V Cargo Launch Vehicle Potential Composite Applications

## 5A Core Stage

<u>Structural Element</u>	<u>Structural Concepts</u>	<u>% Payoff vs. Baseline</u> (Wt., Cost, etc.)
<b>5Aa</b> Forward Adapter	<ul style="list-style-type: none"> <li>• <b>5Aa1</b> Stiffened</li> <li>• <b>5Aa2</b> Sandwich</li> </ul>	<ul style="list-style-type: none"> <li>•</li> <li>•</li> </ul>
<b>5Ab</b> LOX/LH2 Tanks	<ul style="list-style-type: none"> <li>• <b>5Ab1</b> Stiffened</li> <li>• <b>5Ab2</b> Sandwich</li> </ul>	<ul style="list-style-type: none"> <li>•</li> <li>•</li> </ul>
<b>5Ac</b> Intertank	<ul style="list-style-type: none"> <li>• <b>5Ac1</b> Stiffened</li> <li>• <b>5Ac2</b> Sandwich</li> </ul>	<ul style="list-style-type: none"> <li>•</li> <li>•</li> </ul>
<b>5Ad</b> Thrust Structure	<ul style="list-style-type: none"> <li>• <b>5Ad1</b> Truss</li> </ul>	<ul style="list-style-type: none"> <li>•</li> </ul>

# 5 Ares V Cargo Launch Vehicle Potential Composite Applications

## 5B Interstage

<u>Structural Element</u>	<u>Structural Concepts</u>	<u>% Payoff vs. Baseline</u> (Wt., Cost, etc.)
<b>5Ba Shell</b>	<ul style="list-style-type: none"> <li>• <b>5Ba1</b> Sandwich – w/wo stiffeners</li> <li>• <b>5Ba2</b> Monolithic with stiffeners</li> </ul>	<ul style="list-style-type: none"> <li>•</li> <li>•</li> </ul>
<b>5Bb Skirt</b>	<ul style="list-style-type: none"> <li>• <b>5Bb1</b> Sandwich – w/wo stiffeners</li> <li>• <b>5Bb2</b> Monolithic with stiffeners</li> <li>• <b>5Bb3</b> Truss</li> </ul>	<ul style="list-style-type: none"> <li>•</li> <li>•</li> <li>•</li> </ul>



# 5 Ares V Cargo Launch Vehicle Potential Composite Applications

## 5C Earth Departure Stage

<u>Structural Element</u>	<u>Structural Concepts</u>	<u>% Payoff vs. Baseline</u> (Wt., Cost, etc.)
<b>5Ca</b> LOX/LH2 Tanks	<ul style="list-style-type: none"> <li>• <b>5Ca1</b> Sandwich</li> <li>• <b>5Ca2</b> Grid Stiffened</li> <li>• <b>5Ca3</b> Monolithic</li> </ul>	<ul style="list-style-type: none"> <li>•</li> <li>•</li> <li>•</li> </ul>
<b>5Cb</b> Thrust Structure	<ul style="list-style-type: none"> <li>• <b>5Cb1</b> Truss - Comp/Metal joints</li> <li>• <b>5Cb2</b> Stiffened Conical Shell</li> </ul>	<ul style="list-style-type: none"> <li>•</li> <li>•</li> </ul>
<b>5Cc</b> Skirts/Shells	<ul style="list-style-type: none"> <li>• <b>5Cc1</b> Stiffened Cylinders</li> <li>• <b>5Cc2</b> Sandwich Cylinders</li> </ul>	<ul style="list-style-type: none"> <li>•</li> <li>•</li> </ul>

# 5 Ares V Cargo Launch Vehicle Potential Composite Applications

## 5D RSRB

<u>Structural Element</u>	<u>Structural Concepts</u>	<u>% Payoff vs. Baseline</u> (Wt., Cost, etc.)
<b>5Da Propellant Case</b>	<ul style="list-style-type: none"><li>• <b>5Da1</b> Filament Wound</li><li>• <b>5Da2</b> Tow Placement</li></ul>	<ul style="list-style-type: none"><li>•</li><li>•</li></ul>

# Preliminary List of Constellation Program Elements That May Benefit From Use of Composites

<u>Constellation Element</u>	<u>Structural Element</u>
<b>1 Lunar Surface Elements</b> <b>1A Habitats</b> <b>1B Rovers</b> <b>1C Cranes</b>	<b>1Aa Deployable, 1Ab Hybrid - Shell/Deployable, 1Ac Rigid Shells</b> <b>1Ba Body, 1Bb Frame</b> <b>1Ca Boom, 1Cb Joints, 1Cc Mechanisms</b>
<b>2 Lunar Surface Access Module (LSAM)</b> <b>2A Descent Stage</b> <b>2B Ascent Stage</b>	<b>2Aa Crew Module, 2Ab Propellant Tanks, 2Ac Frame</b> <b>2Ba Crew Module, 2Bb Propellant Tanks, 2Bc Frame</b>
<b>3 Ares I</b> <b>3A First Stage</b> <b>3B Interstage</b> <b>3C Upper stage</b> <b>3D CEV</b>	<b>3Aa Forward Adapter, 3Ab RSRB Case</b> <b>3Ba Shell</b> <b>3Ca LOX/LH<sub>2</sub> Tanks, 3Cb Thrust Structure, 3Cc Skirts/Shells</b> (See Orion CEV Breakout Below)
<b>4 Orion Crew Exploration Vehicle</b> <b>4A Space Craft Adapter</b> <b>4B Crew module</b> <b>4C Service Module</b> <b>4D Launch Abort System</b>	<b>4Aa Shell</b> <b>4Ba High q,G,T Pressure Vessel (Crew Module)</b> <b>4Ca LOX/LH<sub>2</sub> Tanks, 4Cb Thrust Structure, 4Cc Skirts/Shells</b> <b>4Da Adapter Cone, 4Db Interstage, 4Dc Shroud, 4Dd Canards</b>
<b>5 Ares V</b> <b>5A Core Stage</b> <b>5B Interstage</b> <b>5C Earth Departure Stage</b> <b>5D RSRB</b> <b>5E LSAM</b>	<b>5Aa Fwd. Adapter, 5Ab LOX/LH<sub>2</sub> Tanks, 5Ac Intertank, 5Ad Thrust Str.</b> <b>5Ba Shell, 5Bb Skirt</b> <b>5Ca LOX/LH<sub>2</sub> Tanks, 5Cb Thrust Structure, 5Cc Skirts/Shells</b> <b>5Da Propellant Case</b> <b>5E (See LSAM Breakout Above)</b>

# Constellation Elements – Constellation Sub-elements Structural Elements – Structural Concepts

<b>Code</b>	<b>Constellation Element</b>	<b>Constellation Subelement</b>	<b>Structural Element</b>	<b>Structural Concept</b>
1Aa1	Lunar Surface Elements	Habitats	Deployable	Rigidizable-Inflatable
1Ab1	Lunar Surface Elements	Habitats	Assemble	Segmented/Prefabs
1Ac1	Lunar Surface Elements	Habitats	Rigidizable-Inflatable	Stiffened
1Ac2	Lunar Surface Elements	Habitats	Rigidizable-Inflatable	Sandwich
1Ba1	Lunar Surface Elements	Rovers	Body	Rigidizable-Inflatable
1Ba2	Lunar Surface Elements	Rovers	Body	Sandwich -w/wo Stiffeners
1Ba3	Lunar Surface Elements	Rovers	Body	Monolithic with stiffeners
1Bb1	Lunar Surface Elements	Rovers	Frame	Truss
1Bb2	Lunar Surface Elements	Rovers	Frame	Beams
1Ca1	Lunar Surface Elements	Cranes	Boom	Truss-Erectable
1Ca2	Lunar Surface Elements	Cranes	Boom	Rigidizable-Inflatable
1Cb1	Lunar Surface Elements	Cranes	Joints	Currently not specified
1Cc1	Lunar Surface Elements	Cranes	Mechanisms	Currently not specified
2Aa1	Lunar Surface Access Module	Descent Stage	Crew Module	Sandwich
2Aa2	Lunar Surface Access Module	Descent Stage	Crew Module	Grid Stiffened
2Aa3	Lunar Surface Access Module	Descent Stage	Crew Module	Monolithic with stiffeners
2Ab1	Lunar Surface Access Module	Descent Stage	Propellant Tanks	COPV Sandwich
2Ab2	Lunar Surface Access Module	Descent Stage	Propellant Tanks	Grid Stiffened
2Ab3	Lunar Surface Access Module	Descent Stage	Propellant Tanks	No Metal Liner Composite
2Ac1	Lunar Surface Access Module	Descent Stage	Frame	Truss-Composite/Metal Joints
2Ac2	Lunar Surface Access Module	Descent Stage	Frame	Hybrid Truss
2Ba1	Lunar Surface Access Module	Ascent Stage	Crew Module	Sandwich
2Ba2	Lunar Surface Access Module	Ascent Stage	Crew Module	Grid Stiffened
2Ba3	Lunar Surface Access Module	Ascent Stage	Crew Module	Monolithic with stiffeners
2Bb1	Lunar Surface Access Module	Ascent Stage	Propellant Tanks	COPV Sandwich
2Bb2	Lunar Surface Access Module	Ascent Stage	Propellant Tanks	Grid Stiffened
2Bb3	Lunar Surface Access Module	Ascent Stage	Propellant Tanks	No Metal Liner Composite
2Bc1	Lunar Surface Access Module	Ascent Stage	Frame	Truss-Composite/Metal Joints
2Bc2	Lunar Surface Access Module	Ascent Stage	Frame	Hybrid Truss

# Constellation Elements – Constellation Sub-elements Structural Elements – Structural Concepts

<b>Code</b>	<b>Constellation Element</b>	<b>Constellation Subelement</b>	<b>Structural Element</b>	<b>Structural Concept</b>
3Aa1	Ares I	First Stage	Forward Adapter	Stiffened Shell
3Aa2	Ares I	First Stage	Forward Adapter	Sandwich Shell
3Ab1	Ares I	First Stage	RSRB Case	Composite Cylinders / Metal Joints
3Ba1	Ares I	Interstage	Shell	Sandwich - w/wo Stiffeners
3Ba2	Ares I	Interstage	Shell	Monolithic with stiffeners
3Ca1	Ares I	Upper Stage	LH2 & LO2 Tanks	Sandwich
3Ca2	Ares I	Upper Stage	LH2 & LO2 Tanks	Grid Stiffened
3Ca3	Ares I	Upper Stage	LH2 & LO2 Tanks	Monolithic
3Cb1	Ares I	Upper Stage	Intertank	Truss - Composite/Metal Joints
3Cb2	Ares I	Upper Stage	Intertank	Stiffened Conical Shell
3Cc1	Ares I	Upper Stage	Thrust Structure	Stiffened Cylinders
3Cc2	Ares I	Upper Stage	Thrust Structure	Sandwich Cylinders
4Aa1	Orion Crew Exploration Vehicle	Soace Craft Adapter	Shell	TBD
4Aa2	Orion Crew Exploration Vehicle	Soace Craft Adapter	Shell	TBD
4Ba1	Orion Crew Exploration Vehicle	Crew Module	High q,G,T Pressure Vessel	TBD
4Ba2	Orion Crew Exploration Vehicle	Crew Module	High q,G,T Pressure Vessel	TBD
4Ca1	Orion Crew Exploration Vehicle	Service Module	LH2 & LO2 Tanks	TBD
4Ca2	Orion Crew Exploration Vehicle	Service Module	LH2 & LO2 Tanks	TBD
4Cb1	Orion Crew Exploration Vehicle	Service Module	Intertank	TBD
4Cb2	Orion Crew Exploration Vehicle	Service Module	Intertank	TBD
4Cc1	Orion Crew Exploration Vehicle	Service Module	Thrust Structure	TBD
4Cc2	Orion Crew Exploration Vehicle	Service Module	Thrust Structure	TBD
4Cd1	Orion Crew Exploration Vehicle	Service Module	Shell	TBD
4Cd2	Orion Crew Exploration Vehicle	Service Module	Shell	TBD
4Da1	Orion Crew Exploration Vehicle	Launch Abort System	Shroud	TBD
4Da2	Orion Crew Exploration Vehicle	Launch Abort System	Shroud	TBD
4Db1	Orion Crew Exploration Vehicle	Launch Abort System	Abort & Jettison Motors	TBD
4Db2	Orion Crew Exploration Vehicle	Launch Abort System	Abort & Jettison Motors	TBD
4Dc1	Orion Crew Exploration Vehicle	Launch Abort System	Nose Cone	TBD
4Dc2	Orion Crew Exploration Vehicle	Launch Abort System	Nose Cone	TBD
4Dd1	Orion Crew Exploration Vehicle	Launch Abort System	Canards	TBD

# Constellation Elements – Constellation Sub-elements Structural Elements – Structural Concepts

<b>Code</b>	<b>Constellation Element</b>	<b>Constellation Subelement</b>	<b>Structural Element</b>	<b>Structural Concept</b>
4Dd2	Orion Crew Exploration Vehicle	Launch Abort System	Canards	TBD
4De1	Orion Crew Exploration Vehicle	Launch Abort System	Interstage	TBD
4De2	Orion Crew Exploration Vehicle	Launch Abort System	Interstage	TBD
4Df1	Orion Crew Exploration Vehicle	Launch Abort System	Adapter Cone	TBD
4Df2	Orion Crew Exploration Vehicle	Launch Abort System	Adapter Cone	TBD
4Dg1	Orion Crew Exploration Vehicle	Launch Abort System	Boost Protective Cover	TBD
4Dg2	Orion Crew Exploration Vehicle	Launch Abort System	Boost Protective Cover	TBD
5Aa1	Ares V	Core Stage	Fwd. Adapter	Stiffened
5Aa2	Ares V	Core Stage	Fwd. Adapter	Sandwich
5Ab1	Ares V	Core Stage	LH2 & LO2 Tanks	Stiffened
5Ab2	Ares V	Core Stage	LH2 & LO2 Tanks	Sandwich
5Ac1	Ares V	Core Stage	Intertank	Stiffened
5Ac2	Ares V	Core Stage	Intertank	Sandwich
5Ad1	Ares V	Core Stage	Thrust Structure	Truss
5Ba1	Ares V	Interstage	Shell	Sandwich w/wo Stiffeners
5Ba2	Ares V	Interstage	Shell	Monolithic with stiffeners
5Bb1	Ares V	Interstage	Skirt	Sandwich w/wo Stiffeners
5Bb2	Ares V	Interstage	Skirt	Monolithic with stiffeners
5Bb3	Ares V	Interstage	Skirt	Truss
5Ca1	Ares V	Earth Departure Stage	LH2 & LO2 Tanks	Sandwich
5Ca2	Ares V	Earth Departure Stage	LH2 & LO2 Tanks	Grid Stiffened
5Ca3	Ares V	Earth Departure Stage	LH2 & LO2 Tanks	Monolithic
5Cb1	Ares V	Earth Departure Stage	Intertank	Truss - Composite/Metal Joints
5Cb2	Ares V	Earth Departure Stage	Intertank	Stiffened Conical Shell
5Cc1	Ares V	Earth Departure Stage	Thrust Structure	Stiffened Cylinders
5Cc2	Ares V	Earth Departure Stage	Thrust Structure	Sandwich Cylinders
5Da1	Ares V	RSRB	Propellant Case	Filament Wound
5Da2	Ares V	RSRB	Propellant Case	Tow Placement



## Composite Technologies Evaluated and Technology Assessment Process

This appendix is a PDF file showing the Microsoft Excel spread sheet used for evaluation of advanced structures technologies for application to NASA's Vision for Space Exploration. The 88 technologies were arranged into 7 areas:

1. Materials and Processes
2. Manufacturing Methods
3. Innovative Design
4. Advanced Analyses, Modeling and Simulation
5. Design Criteria and Allowables
6. Development, Quality Assurance and Certification
7. Threat and Environment

Page five in this section shows the definition of the rating factors used to rank the technologies. Each technology was rated by (1) level of technology development required, (2) degree of importance, and (3) degree of difficulty to mature the technology in time to impact the Constellation Program. The weighted score was calculated by multiplying the degree of difficulty score by the degree of importance score and then multiplying that score by a potential weight saving score which resulted from the weight saving calculations discussed in section C in the main body of this report. An example of the evaluation sheets scored by a member of our team is shown in Appendix C. The spread sheet was programmed to calculate weighted scores and to facilitate sorting into separate sheets that showed:

1. All the data as input
2. R&D only – Those technologies judged to require additional R&D to mature for application
3. ND – Those technologies that could be further matured as part of a typical development project
4. R&D Highest Scores – The top rated R&D technologies for the application being evaluated.

	A	B	C	D	E	F	G	H
1	<b>Composites Technologies Considered For</b>							
2	See Definitions at Bottom of Work Sheet			Potential Weight Saving Score				
3								
4								
5						Enter Four Digit Constellation Element Identification Code and Name of structural element/structural concept( For Example - <u>2Bb1</u> - LSAM/Ascent Module/Propellant Tanks/COPV)		
6	<b>Level of Technology Development Required</b>	<b>Degree of Importance</b>	<b>Degree of Difficulty</b>	<b>Product of Importance and Difficulty</b>	<b>Weighted Score</b>	Enter Your Name (Last, First)		<b>Generate Filtered Data</b>
7								
8								
9								
10	(NR,ND,R&D)	(H=3,M=2,L=1)	(L=3,M=2,H=1)					
11	<b>1 Materials and Processes</b>							
12						1.1	Materials for cryo applications for fuel containment (e.g., microcracking, permeability, durability and insulation)	
13						1.2	Surface preparation and bonding processes for improved adhesive joints	
14						1.3	Bonded joining concepts, e.g. pi-joints	
15						1.4	Co-cure, co-bond, and secondary bond process characterization for repeatable production of bonded structures	
16						1.5	Establish equivalence of out-of-autoclave cure processes by detailed screening, and characterization	
17						1.6	Advanced non-autoclave cure methods	
18						1.7	Long out-time/Long shelf-life materials	
19						1.8	Nanocomposite development	
20						1.9	Metal matrix, hybrid, carbon-carbon and ceramics composites	
21	<b>2 Manufacturing Methods</b>							
22						2.1	Develop improved non-autoclave processes for traditional carbon/resin systems	
23						2.2	Scale up of manufacturing methods to large (33-ft dia) structures	
24						2.3	Manufacturing technologies for large scale structures, e.g., tape/tow/broadgoods placement machines for very high laydown rates	
25						2.4	Develop methodology to address large moments of inertia, stability and structural rigidity of rotating tools for large structures	
26						2.5	Vented core and core splicing technology development	
27						2.6	In-process inspection techniques and acceptance methodology	
28						2.7	Nontraditional cure methods such as ultrasonics	
29						2.8	Low-cost tooling	
30						2.9	Improved assembly process such as self-tooling, reducing imperfections and guaranteeing adequate tolerance	
31	<b>3 Innovative Design</b>							



	A	B	C	D	E	F	G	H
1	<b>Composites Technologies Considered For</b>							
2	See Definitions at Bottom of Work Sheet			Potential Weight Saving Score				
3								
4								
5								
6	<b>Level of Technology Development Required</b>	<b>Degree of Importance</b>	<b>Degree of Difficulty</b>	<b>Product of Importance and Difficulty</b>	<b>Weighted Score</b>	Enter Four Digit Constellation Element Identification Code and Name of structural element/structural concept( For Example - <u>2Bb1</u> - LSAM/Ascent Module/Propellant Tanks/COPV)		Enter Your Name (Last, First)
7								Generate Filtered Data
8								
9								
10	(NR,ND,R&D)	(H=3,M=2,L=1)	(L=3,M=2,H=1)					
32						3.1	Efficient bolted or bonded joints between large sections	
33						3.2	Multifunctional designs (strength, thermal, radiation, acoustic, ...)	
34						3.3	Sandwich Designs	
35						3.4	Iso-, Ortho-Grid Stiffened Designs, selective reinforcement	
36						3.5	Hybrid (metal/Composite) stiffened structures	
37						3.6	Truss Structures	
38						3.7	Tailored (tow steered, variable stiffness) composites	
39						3.8	Primarily Bonded structures	
40						3.9	Stitched Designs	
41						3.10	Point load introduction	
42						3.11	Inflatables	
43						3.12	In-space/ground repair methods	
44						3.13	Nanocomposites for load bearing applications and reduce damage growth	
45						3.14	Nanocomposites for non-load bearing applications such as electrical, IVHM, thermal	
46						3.15	Very high temperature capability as needed for engines and on reentry	
47						3.16	Composite overwrap pressure vessels	
48						3.17	Crashworthiness incorporated in design	
49						3.18	Interaction between components (acoustics issues, payload...)	
50						3.19	Integrated TPS, radiation protection	
51						3.20	Methods of preventing damage growth	
52						3.21	Lightweight mechanisms for load transfer	
53						3.22	Engine components like nozzles and pumps	
54						<b>4 Advanced Analysis, Modeling and Simulation</b>		
55						4.1	Advanced analysis for composite shell structures considering imperfections, failure mechanisms	
56						4.2	Design methodology for stiffener terminations and other discontinuities	

	A	B	C	D	E	F	G	H
1	<b>Composites Technologies Considered For</b>							
2	See Definitions at Bottom of Work Sheet			Potential Weight Saving Score				
3								
4								
5						Enter Four Digit Constellation Element Identification Code and Name of structural element/structural concept( For Example - <u>2Bb1</u> - LSAM/Ascent Module/Propellant Tanks/COPV)		
6	<b>Level of Technology Development Required</b>	<b>Degree of Importance</b>	<b>Degree of Difficulty</b>	<b>Product of Importance and Difficulty</b>	<b>Weighted Score</b>	Enter Your Name (Last, First)		<b>Generate Filtered Data</b>
7								
8								
9								
10	(NR,ND,R&D)	(H=3,M=2,L=1)	(L=3,M=2,H=1)					
57						4.3	Effects of defects in novel design concepts, e.g., missing stitches, local debonds, porosity	
58						4.4	Improved methods of analyzing highly tailored composites	
59						4.5	Simulated test and evaluation of structural designs	
60						4.6	Thermo-structural design, e.g., thermally compliant joints	
61						4.7	Failure mechanism/prediction at RT and at extreme temperatures	
62						4.8	Optimization methods	
63						4.10	Fatigue/life prediction	
64						4.11	Probabilistic design	
65						4.12	Progressive failure methods	
66						4.13	Hierarchical analysis	
67						4.14	Prediction of internal and residual stresses and design to minimize or take advantage of such stresses	
68						4.15	Scaling and validation	
69						4.16	Coupled Loads analysis	
70						<b>5 Design Criteria and Allowables</b>		
71						5.1	Define damage tolerance requirements	
72						5.2	Radiation Protection	
73						5.3	MMOD Resistant Design	
74						5.4	Standardized Allowables such as MIL-HDBK-17 modifications	
75						5.5	In-Space durability and environmental influence on design	
76						5.6	Develop and justify less conservative knockdown factors	
77						5.7	Develop and justify more reasonable safety factors based on aircraft approach	
78						5.8	Develop NDE standards	
79						5.9	Better understand and refine minimum gage specifications	
80						5.10	Develop database for better understanding of damage	
81						<b>6 Development, Quality Assurance and Certification</b>		

	A	B	C	D	E	F	G	H
1	<b>Composites Technologies Considered For</b>							
2	See Definitions at Bottom of Work Sheet			Potential Weight Saving Score				
3								
4								
5								
6	<b>Level of Technology Development Required</b>	<b>Degree of Importance</b>	<b>Degree of Difficulty</b>	<b>Product of Importance and Difficulty</b>	<b>Weighted Score</b>	Enter Four Digit Constellation Element Identification Code and Name of structural element/structural concept( For Example - <u>2Bb1</u> - LSAM/Ascent Module/Propellant Tanks/COPV)		Enter Your Name (Last, First)
7								Generate Filtered Data
8								
9	(NR,ND,R&D)	(H=3,M=2,L=1)	(L=3,M=2,H=1)					
10								
82						6.1	Inspection Methods	
83						6.2	QA to Structural Performance Correlation	
84						6.3	Post-Damage Reliability Prediction	
85						6.4	Structural health monitoring, diagnostics, and prognostics	
86						6.5	Establish Minimum complexity for design hot spot interrogation	
87						6.6	Identify smallest test scale where full environmental (including in-space) simulation is required	
88						6.7	Establish level of certification that can be accomplished by analysis	
89						6.8	Increased reliance on simulation rather than testing for certification	
90						6.9	Reducing development cost	
91						6.10	Improved test methods	
92						6.11	Database development	
93						6.12	Accelerated Aging and accelerated test methods	
94						<b>7</b>	<b>Threat and Environment</b>	
95						7.1	MMOD protection (lunar/IEO)	
96						7.2	Lunar dust impacts	
97						7.3	Improved leak detection	
98						7.4	Aging in lunar environment	
99						7.5	Static charge issues (on Earth or Moon)	
100						7.6	Lunar polar extreme temperature fluctuations	
101						7.7	Radiation hardened structures	
102						7.8	Noise, insulation	
103						7.9	Coatings and sealants	
104						7.10	Toxicity including outgassing	
105								
106								
107								

	A	B	C	D	E	F	G	H
1	<b>Composites Technologies Considered For</b>							
2	See Definitions at Bottom of Work Sheet			Potential Weight Saving Score		<div style="border: 1px solid red; padding: 5px; display: inline-block;"> Enter Four Digit Constellation Element Identification Code and Name of structural element/structural concept( For Example - <u>2Bb1 - LSAM/Ascent Module/Propellant Tanks/COPV</u>) </div> <div style="border: 1px solid blue; padding: 5px; display: inline-block; margin-left: 20px;"> Enter Your Name (Last, First) </div> <div style="border: 1px solid gray; padding: 5px; display: inline-block; margin-left: 20px; margin-top: 10px;"> Generate Filtered Data </div>		
3								
4								
5								
6	Level of Technology Development Required	Degree of Importance	Degree of Difficulty	Product of Importance and Difficulty	Weighted Score			
7								
8								
9								
10	(NR,ND,R&D)	(H=3,M=2,L=1)	(L=3,M=2,H=1)					
108								
109	<b>Definitions</b>							
110	<b>Level of Technology Development Required</b>							
111		NR	Research in this technology area is sufficiently mature or not applicable to the type of structural element under consideration					
112		ND	Normal engineering, development and validation in this technology area are expected to solve any issues related to the type of structural element under consideration.					
113		R&D	Significant research and development are required in this technology area to solve issues related to the type of structural element under consideration.					
114	<b>Degree of Importance</b>							
115		H = 3	Early resolution critical to structural concept and/or meeting schedule					
116		M = 2	Has a quantifiable first order relationship to weight savings					
117		L = 1	Has a second order relationship to weight savings					
118	<b>Degree of Difficulty</b>							
119		L = 3	Low - Potential solutions to barriers for this technology area are <u>known</u> , potential for meeting Constellation Program schedule dates is <u>high</u> , cost and other resources are <u>modest</u> (Technology Readiness Level 5-7)					
120		M = 2	Moderate - Potential solutions to barriers for this technology area are <u>known</u> , potential for meeting Constellation Program schedule dates is <u>low to moderate</u> , cost and other resources are <u>modest to expensive</u> (Technology Readiness Level 4-6)					
121		H = 1	High - Potential solutions to barriers for this technology area are <u>ideas to known</u> , potential for meeting Constellation Program schedule dates is <u>questionable to low</u> , cost and other resources are <u>unknown to expensive</u> (Technology Readiness Level 3-5)					
122								
123	<b>Weighted Score = Product of Degree of Importance times Degree of Difficulty and the Potential Weight Saving Score</b>							



## Appendix A.3

### **Technology Assessment Spreadsheets Example Ares I Upper Stage Cryotanks Common Bulkhead Tank Concept Sandwich Structural Concept 3Ca1 – Constellation Traceability Code (see Appendix A)**

This appendix is a PDF file showing the Microsoft Excel spread sheet used by a single team member for evaluation 88 advanced composite technologies that are divided into seven areas.

Page 6 in this section shows the definition of the rating factors used to rank the technologies. Each technology was rated by (1) level of technology development required, (2) degree of importance, and (3) degree of difficulty to mature the technology in time to impact the Constellation Program. The weighted score was calculated by multiplying the degree of difficulty score by the degree of importance score and then multiplying that score by a potential weight saving score which resulted from the weight saving calculations discussed in section C in the main body of this report.

Pages 2 through 6 list the scoring of all 88 technologies against requirements for application to the Ares I cryogenic propellant tanks. Pages 7 and 8 list all technologies judged to require R & D to meet an acceptable technology readiness level for Ares I.

Page 9 lists the highest scoring technologies.

Pages 10 through 24 list detailed comments about the scoring for each technology.

# List of Technologies - Input Data

1	A	B	C	D	E	F	G	H
1	<b>Composites Technologies Considered For</b>							
2	See Definitions at Bottom of Work Sheet					Potential Weight Saving Score		3Ca1 - Ares1/Upper Stage/ LH2 & LO2 Tanks/Sandwich
3						30		Davis, John
4								
5								
6	<b>Level of Technology Development Required</b>	<b>Degree of Importance</b>	<b>Degree of Difficulty</b>	<b>Product of Importance and Difficulty</b>	<b>Weighted Score</b>	Enter Four Digit Constellation Element Identification Code and Name of structural element/structural concept( For Example - 2Bb1 - LSAM/Ascent Module/Propellant Tanks/COPV)		Enter Your Name (Last, First)
7								Generate Filtered Data
8								
9								
10	(NR,ND,R&D)	(H=3,M=2,L=1)	(L=3,M=2,H=1)					
11	<b>1 Materials and Processes</b>							
12	R&D	3	3	9	270	1.1	Materials for cryo applications for fuel containment (e.g., microcracking, permeability, durability and insulation)	
13	ND	2	3	6	180	1.2	Surface preparation and bonding processes for improved adhesive joints	
14	R&D	3	2	6	180	1.3	Bonded joining concepts, e.g. pi-joints	
15	ND	2	3	6	180	1.4	Co-cure, co-bond, and secondary bond process characterization for repeatable production of bonded structures	
16	ND	2	3	6	180	1.5	Establish equivalence of out-of-autoclave cure processes by detailed screening, and characterization	
17	R&D	2	1	2	60	1.6	Advanced non-autoclave cure methods	
18	NR					1.7	Long out-time/Long shelf-life materials	
19	R&D	1	1	1	30	1.8	Nanocomposite development	
20	NR					1.9	Metal matrix, hybrid, carbon-carbon and ceramics composites	
21	<b>2 Manufacturing Methods</b>							
22	R&D	3	3	9	270	2.1	Develop improved non-autoclave processes for traditional carbon/resin systems	
23	ND	2	3	6	180	2.2	Scale up of manufacturing methods to large (33-ft dia) structures	
24	ND	2	3	6	180	2.3	Manufacturing technologies for large scale structures, e.g., tape/tow/broadgoods placement machines for very high laydown rates	
25	ND	2	3	6	180	2.4	Develop methodology to address large moments of inertia, stability and structural rigidity of rotating tools for large structures	
26	ND	2	3	6	180	2.5	Vented core and core splicing technology development	
27	ND	2	2	4	120	2.6	In-process inspection techniques and acceptance methodology	
28	R&D	3	3	9	270	2.7	Nontraditional cure methods such as ultrasonics	
29	ND	1	2	2	60	2.8	Low-cost tooling	
30	ND	1	2	2	60	2.9	Improved assembly process such as self-tooling, reducing imperfections and guaranteeing adequate tolerance	

# List of Technologies - Input Data

	A	B	C	D	E	F	G	H			
1	<b>Composites Technologies Considered For</b>										
2	See Definitions at Bottom of Work Sheet			Potential Weight Saving Score		3Ca1 - Ares1/Upper Stage/ LH2 & LO2 Tanks/Sandwich					
3				30		Davis, John					
4						Enter Four Digit Constellation Element Identification Code and Name of structural element/structural concept( For Example - 2Bb1 - LSAM/Ascent Module/Propellant Tanks/COPV)					
5						Enter Your Name (Last, First)					
6	<b>Level of Technology Development Required</b>	<b>Degree of Importance</b>	<b>Degree of Difficulty</b>	<b>Product of Importance and Difficulty</b>	<b>Weighted Score</b>	Generate Filtered Data					
7											
8											
9											
10	(NR,ND,R&D)	(H=3,M=2,L=1)	(L=3,M=2,H=1)								
31								<b>3 Innovative Design</b>			
32	R&D	3	3	9	270	3.1 Efficient bolted or bonded joints between large sections					
33	R&D	2	1	2	60	3.2 Multifunctional designs (strength, thermal, radiation, acoustic, ...)					
34	ND	2	2	4	120	3.3 Sandwich Designs					
35	NR					3.4 Iso-, Ortho-Grid Stiffened Designs, selective reinforcement					
36	NR					3.5 Hybrid (metal/Composite) stiffened structures					
37	NR					3.6 Truss Structures					
38	ND	2	2	4	120	3.7 Tailored (tow steered, variable stiffness) composites					
39	ND	2	2	4	120	3.8 Primarily Bonded structures					
40	NR					3.9 Stitched Designs					
41	ND	2	2	4	120	3.10 Point load introduction					
42	NR					3.11 Inflatables					
43	ND	1	2	2	60	3.12 In-space/ground repair methods					
44	NR					3.13 Nanocomposites for load bearing applications and reduce damage growth					
45	NR					3.14 Nanocomposites for non-load bearing applications such as electrical, IVHM, thermal					
46	NR					3.15 Very high temperature capability as needed for engines and on reentry					
47	NR					3.16 Composite overwrap pressure vessels					
48	NR					3.17 Crashworthiness incorporated in design					
49	R&D	3	2	6	180	3.18 Interaction between components (acoustics issues, payload...)					
50	ND	2	2	4	120	3.19 Integrated TPS, radiation protection					
51	ND	2	2	4	120	3.20 Methods of preventing damage growth					
52	ND	2	2	4	120	3.21 Lightweight mechanisms for load transfer					
53	NR					3.22 Engine components like nozzles and pumps					

# List of Technologies - Input Data

1	A	B	C	D	E	F	G	H	
1	<b>Composites Technologies Considered For</b>								
2	See Definitions at Bottom of Work Sheet					Potential Weight Saving Score		3Ca1 - Ares1/Upper Stage/ LH2 & LO2 Tanks/Sandwich	
3						30		Davis, John	
4									
5								Enter Four Digit Constellation Element Identification Code and Name of structural element/structural concept( For Example - 2Bb1 - LSAM/Ascent Module/Propellant Tanks/COPV)	
6								Enter Your Name (Last, First)	
7	Level of Technology Development Required	Degree of Importance	Degree of Difficulty	Product of Importance and Difficulty	Weighted Score			Generate Filtered Data	
8									
9									
10	(NR,ND,R&D)	(H=3,M=2,L=1)	(L=3,M=2,H=1)						
54	<b>4 Advanced Analysis, Modeling and Simulation</b>								
55	R&D	2	2	4	120	4.1	Advanced analysis for composite shell structures considering imperfections, failure mechanisms		
56	R&D	2	2	4	120	4.2	Design methodology for stiffener terminations and other discontinuities		
57	R&D	2	2	4	120	4.3	Effects of defects in novel design concepts, e.g., missing stitches, local debonds, porosity		
58	R&D	2	2	4	120	4.4	Improved methods of analyzing highly tailored composites		
59	R&D	1	1	1	30	4.5	Simulated test and evaluation of structural designs		
60	R&D	3	3	9	270	4.6	Thermo-structural design, e.g., thermally compliant joints		
61	R&D	3	3	9	270	4.7	Failure mechanism/prediction at RT and at extreme temperatures		
62	R&D	2	1	2	60	4.8	Optimization methods		
63	NR					4.10	Fatigue/life prediction		
64	R&D	2	1	2	60	4.11	Probabilistic design		
65	R&D	2	1	2	60	4.12	Progressive failure methods		
66	R&D	2	1	2	60	4.13	Hierarchical analysis		
67	R&D	2	1	2	60	4.14	Prediction of internal and residual stresses and design to minimize or take advantage of such stresses		
68	R&D	1	1	1	30	4.15	Scaling and validation		
69	R&D	2	1	2	60	4.16	Coupled Loads analysis		
70	<b>5 Design Criteria and Allowables</b>								
71	ND	2	2	4	120	5.1	Define damage tolerance requirements		
72	NR					5.2	Radiation Protection		
73	NR					5.3	MMOD Resistant Design		
74	ND	2	3	6	180	5.4	Standardized Allowables such as MIL-HDBK-17 modifications		
75	NR					5.5	In-Space durability and environmental influence on design		
76	R&D	2	2	4	120	5.6	Develop and justify less conservative knockdown factors		
77	R&D	2	1	2	60	5.7	Develop and justify more reasonable safety factors based on aircraft approach		
78	ND	2	2	4	120	5.8	Develop NDE standards		
79	ND	2	2	4	120	5.9	Better understand and refine minimum gage specifications		
80	ND	2	2	4	120	5.10	Develop database for better understanding of damage		



# List of Technologies - Input Data

	A	B	C	D	E	F	G	H	
1	<b>Composites Technologies Considered For</b>								
2	See Definitions at Bottom of Work Sheet					Potential Weight Saving Score		3Ca1 - Ares1/Upper Stage/ LH2 & LO2 Tanks/Sandwich	
3						<b>30</b>		Davis, John	
4									
5									
6	<b>Level of Technology Development Required</b>	<b>Degree of Importance</b>	<b>Degree of Difficulty</b>	<b>Product of Importance and Difficulty</b>	<b>Weighted Score</b>	Enter Four Digit Constellation Element Identification Code and Name of structural element/structural concept( For Example - 2Bb1 - LSAM/Ascent Module/Propellant Tanks/COPV)		Enter Your Name (Last, First)	
7									
8									
9									
10	(NR,ND,R&D)	(H=3,M=2,L=1)	(L=3,M=2,H=1)					Generate Filtered Data	
81	<b>6 Development, Quality Assurance and Certification</b>								
82	ND	2	2	4	120	6.1	Inspection Methods		
83	R&D	2	1	2	60	6.2	QA to Structural Performance Correlation		
84	R&D	2	1	2	60	6.3	Post-Damage Reliability Prediction		
85	R&D	2	1	2	60	6.4	Structural health monitoring, diagnostics, and prognostics		
86	R&D	2	1	2	60	6.5	Establish Minimum complexity for design hot spot interrogation		
87	R&D	1	1	1	30	6.6	Identify smallest test scale where full environmental (including in-space) simulation is required		
88	R&D	1	1	1	30	6.7	Establish level of certification that can be accomplished by analysis		
89	R&D	1	1	1	30	6.8	Increased reliance on simulation rather than testing for certification		
90	R&D	1	3	3	90	6.9	Reducing development cost		
91	NR					6.10	Improved test methods		
92	ND	2	2	4	120	6.11	Database development		
93	NR					6.12	Accelerated Aging and accelerated test methods		
94	<b>7 Threat and Environment</b>								
95	NR					7.1	MMOD protection (lunar/IEO)		
96	NR					7.2	Lunar dust impacts		
97	ND	2	2	4	120	7.3	Improved leak detection		
98	NR					7.4	Aging in lunar environment		
99	ND	1	3	3	90	7.5	Static charge issues (on Earth or Moon)		
100	NR					7.6	Lunar polar extreme temperature fluctuations		
101	NR					7.7	Radiation hardened structures		
102	NR					7.8	Noise, insulation		
103	ND	2	2	4	120	7.9	Coatings and sealants		
104	NR					7.10	Toxicity including outgassing		
105									

# List of Technologies - Input Data

	A	B	C	D	E	F	G	H
1	<b>Composites Technologies Considered For</b>							
2	See Definitions at Bottom of Work Sheet					Potential Weight Saving Score		3Ca1 - Ares1/Upper Stage/ LH2 & LO2 Tanks/Sandwich
3						30		Davis, John
4								
5								
6	<b>Level of Technology Development Required</b>	<b>Degree of Importance</b>	<b>Degree of Difficulty</b>	<b>Product of Importance and Difficulty</b>	<b>Weighted Score</b>	Enter Four Digit Constellation Element Identification Code and Name of structural element/structural concept( For Example - 2Bb1 - LSAM/Ascent Module/Propellant Tanks/COPV)		Enter Your Name (Last, First)
7								Generate Filtered Data
8								
9	(NR,ND,R&D)	(H=3,M=2,L=1)	(L=3,M=2,H=1)					
10								
106								
107								
108								
109	<b>Definitions</b>							
110	<b>Level of Technology Development Required</b>							
111		NR	Research in this technology area is sufficiently mature or not applicable to the type of structural element under consideration					
112		ND	Normal engineering, development and validation in this technology area are expected to solve any issues related to the type of structural element under consideration.					
113		R&D	Significant research and development are required in this technology area to solve issues related to the type of structural element under consideration.					
114	<b>Degree of Importance</b>							
115		H = 3	Early resolution critical to structural concept and/or meeting schedule					
116		M = 2	Has a quantifiable first order relationship to weight savings					
117		L = 1	Has a second order relationship to weight savings					
118	<b>Degree of Difficulty</b>							
119		L = 3	Low - Potential solutions to barriers for this technology area are <u>known</u> , potential for meeting Constellation Program schedule dates is <u>high</u> , cost and other resources are <u>modest</u> (Technology Readiness Level 5-7)					
120		M = 2	Moderate - Potential solutions to barriers for this technology area are <u>known</u> , potential for meeting Constellation Program schedule dates is <u>low to moderate</u> , cost and other resources are <u>modest to expensive</u> (Technology Readiness Level 4-6)					
121		H = 1	High - Potential solutions to barriers for this technology area are <u>ideas to known</u> , potential for meeting Constellation Program schedule dates is <u>questionable to low</u> , cost and other resources are <u>unknown to expensive</u> (Technology Readiness Level 3-5)					
122								
123	<b>Weighted Score = Product of Degree of Importance times Degree of Difficulty and the Potential Weight Saving Score</b>							

# List of Technologies Requiring R and D

	A	B	C	D	E	F	G	H
1	<b>Composites Technologies Considered For</b>							
2	See Definitions at Bottom of Work Sheet			Potential Weight Saving Score		3Ca1 - Ares1/Upper Stage/ LH2 & LO2 Tanks/Sandwich		
3				30		Davis, John		
4						Enter Four Digit Constellation Element Identification Code and Name of structural element/structural concept( For Example - 2Bb1 - LSAM/Ascent Module/Propellant Tanks/COPV)		
5						Enter Your Name (Last, First)		
6	Level of Technology Development Required	Degree of Importance	Degree of Difficulty	Product of Importance and Difficulty	Weighted Score			
7								
8								
9								
10	(NR,ND,R&D)	(H=3,M=2,L=1)	(L=3,M=2,H=1)					
11	<b>1 Materials and Processes</b>							
12	R&D	3	3	9	270	1.1	Materials for cryo applications for fuel containment (e.g., microcracking, permeability, durability and insulation)	
13	R&D	3	2	6	180	1.3	Bonded joining concepts, e.g. pi-joints	
14	R&D	2	1	2	60	1.6	Advanced non-autoclave cure methods	
15	R&D	1	1	1	30	1.8	Nanocomposite development	
16	<b>2 Manufacturing Methods</b>							
17	R&D	3	3	9	270	2.1	Develop improved non-autoclave processes for traditional carbon/resin systems	
18	R&D	3	3	9	270	2.7	Nontraditional cure methods such as ultrasonics	
19	<b>3 Innovative Design</b>							
20	R&D	3	3	9	270	3.1	Efficient bolted or bonded joints between large sections	
21	R&D	2	1	2	60	3.2	Multifunctional designs (strength, thermal, radiation, acoustic, ...)	
22	R&D	3	2	6	180	3.18	Interaction between components (acoustics issues, payload...)	
23	<b>4 Advanced Analysis, Modeling and Simulation</b>							
24	R&D	2	2	4	120	4.1	Advanced analysis for composite shell structures considering imperfections, failure mechanisms	
25	R&D	2	2	4	120	4.2	Design methodology for stiffener terminations and other discontinuities	
26	R&D	2	2	4	120	4.3	Effects of defects in novel design concepts, e.g., missing stitches, local debonds, porosity	
27	R&D	2	2	4	120	4.4	Improved methods of analyzing highly tailored composites	
28	R&D	1	1	1	30	4.5	Simulated test and evaluation of structural designs	
29	R&D	3	3	9	270	4.6	Thermo-structural design, e.g., thermally compliant joints	
30	R&D	3	3	9	270	4.7	Failure mechanism/prediction at RT and at extreme temperatures	
31	R&D	2	1	2	60	4.8	Optimization methods	
32	R&D	2	1	2	60	4.11	Probabilistic design	
33	R&D	2	1	2	60	4.12	Progressive failure methods	
34	R&D	2	1	2	60	4.13	Hierarchical analysis	

# List of Technologies Requiring R and D

A	B	C	D	E	F	G	H		
1	<b>Composites Technologies Considered For</b>								
2	See Definitions at Bottom of Work Sheet			Potential Weight Saving Score		3Ca1 - Ares1/Upper Stage/ LH2 & LO2 Tanks/Sandwich			
3				30		Davis, John			
4						Enter Four Digit Constellation Element Identification Code and Name of structural element/structural concept( For Example - <u>2Bb1 - LSAM/Ascent Module/Propellant Tanks/COPV</u> )			
5									
6								Enter Your Name (Last, First)	
7	<b>Level of Technology Development Required</b>	<b>Degree of Importance</b>	<b>Degree of Difficulty</b>	<b>Product of Importance and Difficulty</b>	<b>Weighted Score</b>				
8	<b>(NR,ND,R&amp;D)</b>	<b>(H=3,M=2,L=1)</b>	<b>(L=3,M=2,H=1)</b>						
9									
10									
35	R&D	2	1	2	60	4.14	Prediction of internal and residual stresses and design to minimize or take advantage of such stresses		
36	R&D	1	1	1	30	4.15	Scaling and validation		
37	R&D	2	1	2	60	4.16	Coupled Loads analysis		
38	<b>5 Design Criteria and Allowables</b>								
39	R&D	2	2	4	120	5.6	Develop and justify less conservative knockdown factors		
40	R&D	2	1	2	60	5.7	Develop and justify more reasonable safety factors based on aircraft approach		
41	<b>6 Development, Quality Assurance and Certification</b>								
42	R&D	2	1	2	60	6.2	QA to Structural Performance Correlation		
43	R&D	2	1	2	60	6.3	Post-Damage Reliability Prediction		
44	R&D	2	1	2	60	6.4	Structural health monitoring, diagnostics, and prognostics		
45	R&D	2	1	2	60	6.5	Establish Minimum complexity for design hot spot interrogation		
46	R&D	1	1	1	30	6.6	Identify smallest test scale where full environmental (including in-space) simulation is required		
47	R&D	1	1	1	30	6.7	Establish level of certification that can be accomplished by analysis		
48	R&D	1	1	1	30	6.8	Increased reliance on simulation rather than testing for certification		
49	R&D	1	3	3	90	6.9	Reducing development cost		

# List of Highest Score Technologies Requiring R and D

	A	B	C	D	E	F	G	H			
1	<b>Composites Technologies Considered For</b>										
2	See Definitions at Bottom of Work Sheet				Potential Weight Saving Score		3Ca1 - Ares1/Upper Stage/ LH2 & LO2 Tanks/Sandwich				
3					30		Davis, John				
4							Enter Four Digit Constellation Element Identification Code and Name of structural element/structural concept( For Example - <u>2Bb1</u> - LSAM/Ascent Module/Propellant Tanks/COPV)				
5									Enter Your Name (Last, First)		
6	<b>Level of Technology Development Required</b>	<b>Degree of Importance</b>	<b>Degree of Difficulty</b>	<b>Product of Importance and Difficulty</b>	<b>Weighted Score</b>						
7											
8	(NR,ND,R&D)	(H=3,M=2,L=1)	(L=3,M=2,H=1)								
9											
10											
11						<b>1 Materials and Processes</b>					
12	R&D	3	3	9	270	1.1	Materials for cryo applications for fuel containment (e.g., microcracking, permeability, durability and insulation)				
13						<b>2 Manufacturing Methods</b>					
14	R&D	3	3	9	270	2.1	Develop improved non-autoclave processes for traditional carbon/resin systems				
15	R&D	3	3	9	270	2.7	Nontraditional cure methods such as ultrasonics				
16						<b>3 Innovative Design</b>					
17	R&D	3	3	9	270	3.1	Efficient bolted or bonded joints between large sections				
18						<b>4 Advanced Analysis, Modeling and Simulation</b>					
19	R&D	3	3	9	270	4.6	Thermo-structural design, e.g., thermally compliant joints				
20	R&D	3	3	9	270	4.7	Failure mechanism/prediction at RT and at extreme temperatures				

## Supporting Comments for Technology Assessments For Ares I Upper Stage LH2 and LO2 Cryotanks Sandwich - Common Bulkhead Concept

<u>LT</u>	<u>DI</u>	<u>DD</u>	<u>No.</u>	<u>Technology</u>	<u>Comments</u>
			<b>1.0</b>	<b>Materials and Processes</b>	
R&D	3	2	1.1	Materials for cryo applications for fuel containment (e.g., microcracking, permeability, durability and insulation)	Tougher Resins or film barriers are required. HEI 535 may have potential. Non Autoclave Cure is essential. Weight Savings Potential of 50%. Tensile strength of ET foam insulation not sufficient to prevent cracking.
ND	2	3	1.2	Surface preparation and bonding processes for improved adhesive joints	Light weight designs require efficient joining of LO2/LH2 bulkhead and forward and aft skirts. Knowledge gained in NGLT, Boeing 787 and other is the basis for DD of 2.
R&D	3	2	1.3	Bonded joining concepts, e.g. pi-joints	Same comments as 1.2 plus sophisticated designs that can support the large thermal gradients for cryotanks.
ND	2	3	1.4	Co-cure, co-bond, and secondary bond process characterization for repeatable production of bonded structures	Same Comments as 1.2.

## Supporting Comments for Technology Assessments For Ares I Upper Stage LH2 and LO2 Cryotanks Sandwich - Common Bulkhead Concept

<u>LT</u>	<u>DI</u>	<u>DD</u>	<u>No.</u>	<u>Technology</u>	<u>Comments</u>
ND	3	3	1.5	Establish equivalence of out-of-autoclave cure processes by detailed screening, and characterization	Non Autoclave Cure is essential. Screening and Characterization is straight forward task.
R&D	3	1	1.6	Advanced non-autoclave cure methods	ATK Ultrasonic heated head shows promise. Other techniques for heating and compacting needed to be explored.
NR			1.7	Long out-time/Long shelf-life materials	Fabrication will be highly automated and resins selected or developed are expected to have adequate out-times
R&D	1	1	1.8	Nanocomposite development	Development time is probably beyond Ares V development schedule
NR			1.9	Metal matrix, hybrid, carbon-carbon and ceramics composites	No apparent application in cryotanks
			<b>2.0</b>	<b>Manufacturing Methods</b>	
R&D	3	3	2.1	Develop improved non-autoclave processes for traditional carbon/resin systems	None autoclave is essential and traditional materials with a liner is a potential solution. Also, applicable to large skirts Intertanks that have less severe requirements on microcracking.

## Supporting Comments for Technology Assessments For Ares I Upper Stage LH2 and LO2 Cryotanks Sandwich - Common Bulkhead Concept

<u>LT</u>	<u>DI</u>	<u>DD</u>	<u>No.</u>	<u>Technology</u>	<u>Comments</u>
ND	2	3	2.2	Scale up of manufacturing methods to large (33-ft dia) structures	Non Autoclave Cure is the largest obstacle and it is covered in 1.5,1.6 & 2.1
ND	2	3	2.3	Manufacturing technologies for large scale structures, e.g., tape/tow/broad goods placement machines for very high lay down rates	See 2.2. Experienced gained on Boeing 787 and aerospace applications can be exploited.
ND	2	3	2.4	Develop methodology to address large moments of inertia, stability and structural rigidity of rotating tools for large structures	Cryotanks will be very light weight large diameter structures. Rotation speeds and tooling weights will be in a low to moderate range.
ND	2	3	2.5	Vented core and core splicing technology development	Based on NGLT program results the concept showed promise. Offers a potential solution for vacuum sandwich design and purging with insert gas.
ND	2	2	2.6	In-process inspection techniques and acceptance methodology	Application of SOA methods to special joints or load introduction points is the major need.
R&D	3	3	2.7	Nontraditional cure methods such as ultrasonics	Need to explore for potential non autoclave cure process



## Supporting Comments for Technology Assessments For Ares I Upper Stage LH2 and LO2 Cryotanks Sandwich - Common Bulkhead Concept

<u>LT</u>	<u>DI</u>	<u>DD</u>	<u>No.</u>	<u>Technology</u>	<u>Comments</u>
ND	1	2	2.8	Low-cost tooling	Low production rates and simple shapes limit the importance of this technology area
ND	1	2	2.9	Improved assembly process such as self-tooling, reducing imperfections and guaranteeing adequate tolerance	See 2.8. Tolerances will not different much from current aerospace composite structures.
			<b>3.0</b>	<b>Innovative Design</b>	
R&D	3	3	3.1	Efficient bolted or bonded joints between large sections	Light weight designs that can withstand large temperature gradients are required.
R&D	2	1	3.2	Multifunctional designs (strength, thermal, radiation, acoustic, ...)	Has potential for later updates of Ares I and V. This capability would be invaluable to technologist and Constellation Program Designers. Part of Space Structures Design Guide.

## Supporting Comments for Technology Assessments For Ares I Upper Stage LH2 and LO2 Cryotanks Sandwich - Common Bulkhead Concept

<u>LT</u>	<u>DI</u>	<u>DD</u>	<u>No.</u>	<u>Technology</u>	<u>Comments</u>
ND	2	2	3.3	Sandwich Designs	Close-outs, joints and load introduction points are major concerns. Existing tools can provide solutions for Ares I and Ares V. This technology would be a major contribution to a Space Structures Design Guide
NR			3.4	Iso-, Ortho-Grid Stiffened Designs, selective reinforcement	Complex tooling required to fabricate and large temperature across the skin to stringer intersection are major barriers to use of this concept in cryotanks.
NR			3.5	Hybrid (metal/Composite) stiffened structures	Low potential for application to cryotanks
NR			3.6	Truss Structures	Low potential for application to cryotanks
ND	2	2	3.7	Tailored (tow steered, variable stiffness) composites	Applicable to Cylinder to Dome transition region of tanks and build-up sections for joints or point load introduction.
ND	2	2	3.8	Primarily Bonded structures	Face sheet to core
NR			3.9	Stitched Designs	Not a good choice for LH2 cryotanks. High potential for stitch patch to leak.

## Supporting Comments for Technology Assessments For Ares I Upper Stage LH2 and LO2 Cryotanks Sandwich - Common Bulkhead Concept

<u>LT</u>	<u>DI</u>	<u>DD</u>	<u>No.</u>	<u>Technology</u>	<u>Comments</u>
ND	2	2	3.10	Point load introduction	See comments for 3.1 & 3.3
NR			3.11	Inflatables	Not applicable to cryotanks.
ND	1	2	3.12	In-space/ground repair methods	In-space repair not required. Since vehicles are single use and man rated the scenario of repairs is expected to be very limited.
NR			3.13	Nanocomposites for load bearing applications and reduce damage growth	No known requirement for Ares I or Ares V cryotanks.
NR			3.14	Nanocomposites for non-load bearing applications such as electrical, IVHM, thermal	No known requirement for Ares I or Ares V cryotanks.
NR			3.15	Very high temperature capability as needed for engines and on reentry	Ares I tanks are expendable, will be insulated to control boil-off and are not subject to radiation heating from rocket engines.
NR			3.16	Composite overwrap pressure vessels	Due to size and shape of Ares I cryotanks, a very thin metal liner may be considered for a permeation barrier, but most likely would not be designed to support any of the internal pressure or combined axial/bending loads.

## Supporting Comments for Technology Assessments For Ares I Upper Stage LH2 and LO2 Cryotanks Sandwich - Common Bulkhead Concept

<u>LT</u>	<u>DI</u>	<u>DD</u>	<u>No.</u>	<u>Technology</u>	<u>Comments</u>
NR			3.17	Crashworthiness incorporated in design	No known requirement for Ares I or Ares V cryotanks.
R&D	3	2	3.18	Interaction between components (acoustics issues, payload...)	Need is based on reports from Orion Project. This capability would be invaluable to technologist and Constellation Program Designers. Part of Space Structures Design Guide.
ND	2	2	3.19	Integrated TPS, radiation protection	Must satisfy the need for a foam that may be bonded or sprayed on the composite skin and not crack when cooled to - 423°F.
ND	2	2	3.20	Methods of preventing damage growth	Designs will have to be analyzed and verification tests conducted to demonstrate that any damage not discovered by inspection or inflicted after the vehicle is loaded with fuel will not result in failure before the cryotanks is separated from the crew and payload.

## Supporting Comments for Technology Assessments For Ares I Upper Stage LH2 and LO2 Cryotanks Sandwich - Common Bulkhead Concept

<u>LT</u>	<u>DI</u>	<u>DD</u>	<u>No.</u>	<u>Technology</u>	<u>Comments</u>
ND	2	2	3.21	Lightweight mechanisms for load transfer	See comments for 3.1, 3.3 & 3.10. This technology would be a major contribution to a Space Structures Design Guide
NR			3.22	Engine components like nozzles and pumps	No known requirement for Ares I or Ares V cryotanks.
			<b>4.0</b>	<b>Advanced Analysis, Modeling and Simulation</b>	
R&D	2	2	4.1	Advanced analysis for composite shell structures considering imperfections, failure mechanisms	Current design requirements impose knockdowns on predicted instability failure modes. Also, ply-drops are considered stress concentrations and knockdowns are dictated. These penalties are not expected to have a major impact on the current concept, since wall thickness is dominated by internal pressure.
R&D	2	2	4.2	Design methodology for stiffener terminations and other discontinuities	See comments for 3.21
R&D	2	2	4.3	Effects of defects in novel design concepts, e.g., missing stitches, local debonds, porosity	See comments for 4.1

## Supporting Comments for Technology Assessments For Ares I Upper Stage LH2 and LO2 Cryotanks Sandwich - Common Bulkhead Concept

<u>LT</u>	<u>DI</u>	<u>DD</u>	<u>No.</u>	<u>Technology</u>	<u>Comments</u>
R&D	2	2	4.4	Improved methods of analyzing highly tailored composites	See comments for 3.7. This capability would be invaluable to technologist and Constellation Program Designers. Part of Space Structures Design Guide.
R&D	1	1	4.5	Simulated test and evaluation of structural designs	Has potential to significantly reduce the cost of structural development but time required to develop is not compatible with Ares I and Ares V development.
R&D	3	3	4.6	Thermo-structural design, e.g., thermally compliant joints	See comments for 3.1.
R&D	3	3	4.7	Failure mechanism/prediction at RT and at extreme temperatures	See comments for 3.1. Primary concern is for joints, point loads, etc.
R&D	2	1	4.8	Optimization methods	Has potential to significantly reduce structural weight but time required to develop is not compatible with Ares I and Ares V development.
NR			4.10	Fatigue/life prediction	Only one flight. Perhaps several times of filling the tank because of launch delays.

## Supporting Comments for Technology Assessments For Ares I Upper Stage LH2 and LO2 Cryotanks Sandwich - Common Bulkhead Concept

<u>LT</u>	<u>DI</u>	<u>DD</u>	<u>No.</u>	<u>Technology</u>	<u>Comments</u>
R&D	2	1	4.11	Probabilistic design	Has potential to significantly reduce structural weight but time required to develop is not compatible with Ares I and Ares V development.
R&D	2	1	4.12	Progressive failure methods	Has potential to significantly reduce structural weight but time required to develop is not compatible with Ares I and Ares V development.
R&D	2	1	4.13	Hierarchical analysis	Has potential to significantly reduce structural weight and development costs, but time required to develop is not compatible with Ares I and Ares V development.
R&D	2	1	4.14	Prediction of internal and residual stresses and design to minimize or take advantage of such stresses	Should be part of structural optimization to achieve minimum weight designs. Time to develop is not compatible with Ares I and Ares V schedule.
R&D	1	1	4.15	Scaling and validation	See comments for 4.5.
R&D	2	1	4.16	Coupled Loads analysis	See comments for 3.2
			<b>5.0</b>	<b>Design Criteria and Allowables</b>	
ND	2	2	5.1	Define damage tolerance requirements	See comments for 3.20.

## Supporting Comments for Technology Assessments For Ares I Upper Stage LH2 and LO2 Cryotanks Sandwich - Common Bulkhead Concept

<u>LT</u>	<u>DI</u>	<u>DD</u>	<u>No.</u>	<u>Technology</u>	<u>Comments</u>
NR			5.2	Radiation Protection	Tank separation occurs before radiation becomes a problem.
NR			5.3	MMOD Resistant Design	Tank separation occurs before MMOD becomes a problem.
ND	2	3	5.4	Standardized Allowables such as MIL-HDBK-17 modifications	Work should be completed before detailed design is started. Data bases exist for numerous composite materials. Test will have to be conducted on new materials that meet microcracking, permeability and non autoclave processing requirements.
NR			5.5	In-Space durability and environmental influence on design	Tank separation occurs before MMOD becomes a problem.
R&D	2	2	5.6	Develop and justify less conservative knockdown factors	See Comments on 4.1
R&D	2	1	5.7	Develop and justify more reasonable safety factors based on aircraft approach	Safety factors should be based on integrity of the structure. Aircraft factor of 1.5 for Ultimate may or may not be conservative for space
ND	2	2	5.8	Develop NDE standards	Major need is standard for quantitative bond strength



## Supporting Comments for Technology Assessments For Ares I Upper Stage LH2 and LO2 Cryotanks Sandwich - Common Bulkhead Concept

<u>LT</u>	<u>DI</u>	<u>DD</u>	<u>No.</u>	<u>Technology</u>	<u>Comments</u>
ND	2	2	5.9	Better understand and refine minimum gage specifications	Should be a part of a Space Structures Design Guide.
ND	2	2	5.1	Develop database for better understanding of damage	Should be a part of a Space Structures Design Guide.
			<b>6.0</b>	<b>Development, Quality Assurance and Certification</b>	
ND	2	2	6.1	Inspection Methods	See comments for 1.2, 3.8, 5.8
R&D	2	1	6.2	QA to Structural Performance Correlation	This has long been a goal of aerospace technologist. A knowledge base in this area would be invaluable. Development time is not compatible with Ares I and V schedules. Results of this R&D should be an integral part of a Space Structure Design Guide.

## Supporting Comments for Technology Assessments For Ares I Upper Stage LH2 and LO2 Cryotanks Sandwich - Common Bulkhead Concept

<u>LT</u>	<u>DI</u>	<u>DD</u>	<u>No.</u>	<u>Technology</u>	<u>Comments</u>
R&D	2	1	6.3	Post-Damage Reliability Prediction	Two items must be known. First, the extent of damage which must be determined by some form of NDE. Second, an analysis that accounts for the local damage area/volume of structure and relates that damage state to the overall performance of the structure. This is judged to be a very challenging tasks and is not expected to meet the Ares I or V schedule.
R&D	2	1	6.4	Structural health monitoring, diagnostics, and prognostics	See comments for 6.3 and add difficulty of real time interpreting of data and instantaneously performing analysis.
R&D	2	1	6.5	Establish Minimum complexity for design hot spot interrogation	See comments for 6.3.
R&D	1	1	6.6	Identify smallest test scale where full environmental (including in-space) simulation is required	See comments for 4.5.
R&D	1	1	6.7	Establish level of certification that can be accomplished by analysis	See comments for 4.5.

## Supporting Comments for Technology Assessments For Ares I Upper Stage LH2 and LO2 Cryotanks Sandwich - Common Bulkhead Concept

<u>LT</u>	<u>DI</u>	<u>DD</u>	<u>No.</u>	<u>Technology</u>	<u>Comments</u>
R&D	1	1	6.8	Increased reliance on simulation rather than testing for certification	See comments for 4.5
R&D	1	3	6.9	Reducing development cost	Two items would have a major impact. One, combining all design requirements into a single, non overlapping document. Two, a desk top computational code that could be used by technologist to evaluate conceptual designs of cryotanks.
NR			6.10	Improved test methods	Simple test except for joints
ND	2	2	6.11	Database development	Needed to before detailed design
NR			6.12	Accelerated Aging and accelerated test methods	Short life, expendable tank
			<b>7.0</b>	<b>Threat and Environment</b>	
NR			7.1	MMOD protection (lunar/IEO)	See comments for 5.3
NR			7.2	Lunar dust impacts	Tank does not go to Lunar Surface
ND	2	2	7.3	Improved leak detection	Use NGLT and ET data.
NR			7.4	Aging in lunar environment	Tank does not go to Lunar Surface
ND	1	3	7.5	Static charge issues (on Earth or Moon)	Use concepts in current transport aircraft.
NR			7.6	Lunar polar extreme temperature fluctuations	Tank does not go to Lunar Surface

## Supporting Comments for Technology Assessments For Ares I Upper Stage LH2 and LO2 Cryotanks Sandwich - Common Bulkhead Concept

<u>LT</u>	<u>DI</u>	<u>DD</u>	<u>No.</u>	<u>Technology</u>	<u>Comments</u>
NR			7.7	Radiation hardened structures	Tank separation occurs before radiation becomes a problem.
NR			7.8	Noise, insulation	Items contained in tank are not expected to require protection
ND	2	2	7.9	Coatings and sealants	Use NGLT and ET data.
NR			7.10	Toxicity including outgassing	Tank does not go to Lunar Surface



## **Lightweight Composite Propellant Tanks for Lunar Surface Access Module (LSAM) Storyboard**

The term “storybook” is used to refer to the overall process followed when evaluating the potential weight savings of advanced composite structures applied to a particular Constellation Element. This process entailed looking at:

Weight saving potential

Ranking of technologies

Identification of critical technology barriers

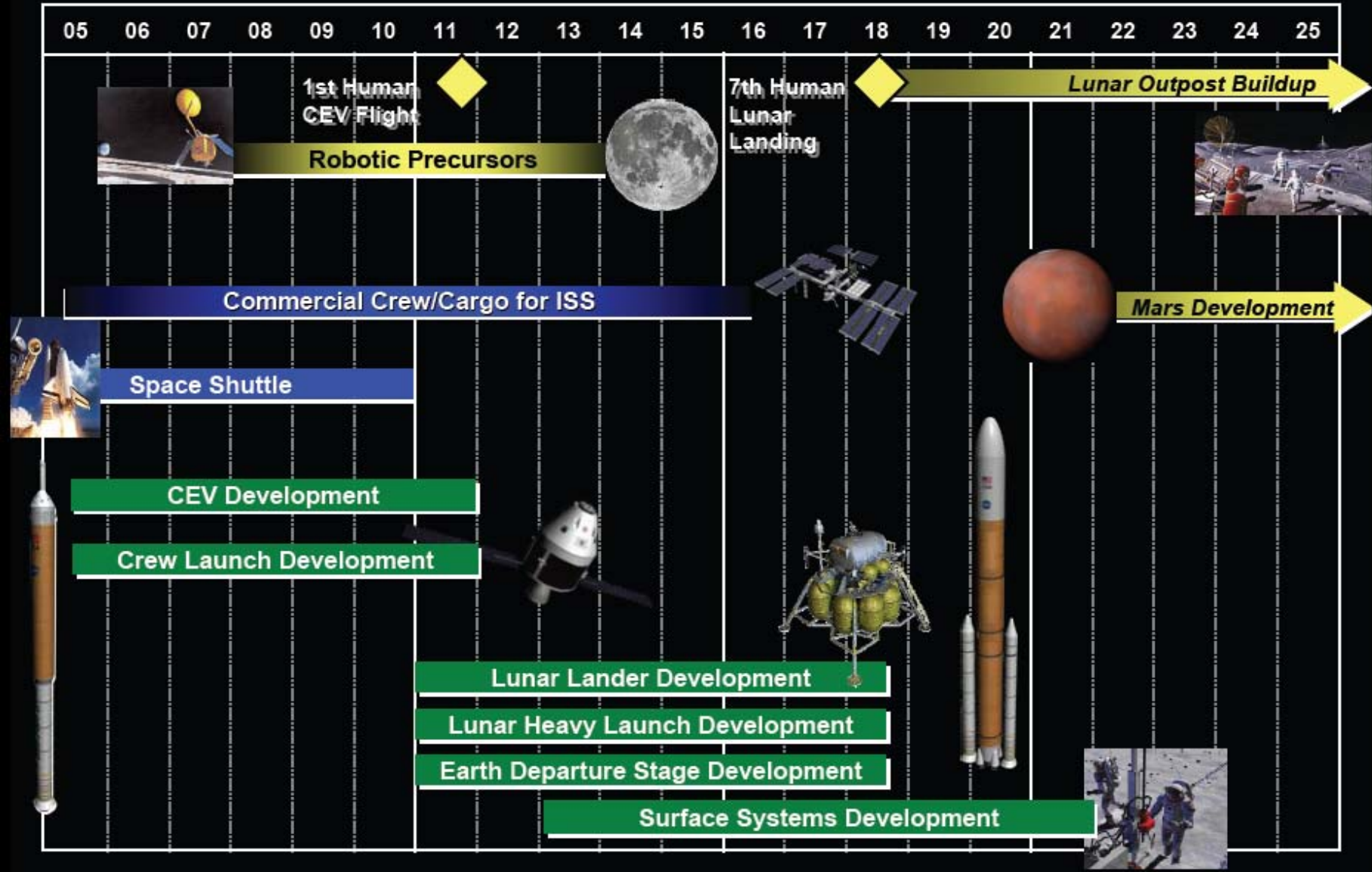
Developing proposed solutions to mature technology

This appendix contains an example of one of these storyboards. The charts developed in the study of propellant tanks for the Lunar Surface Access Module (LSAM) are contained in this appendix.

## Table of Contents

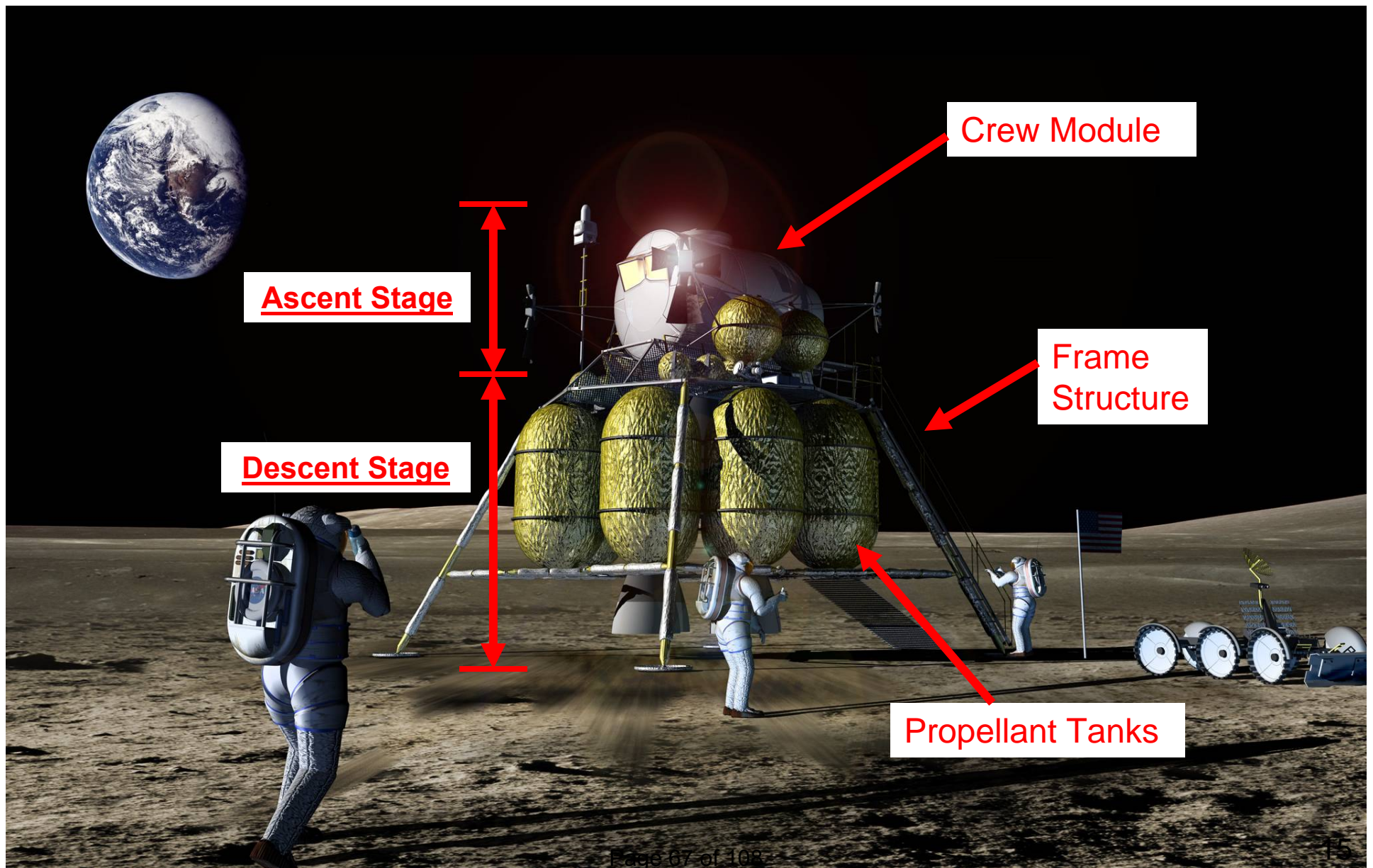
<b><u>Charts</u></b>	<b><u>Description</u></b>
<b>3</b>	<b>Constellation Roadmap &amp; Elements</b>
<b>4 - 6</b>	<b>Lunar Surface Access Module (LSAM)</b>
<b>7 - 9</b>	<b>Apollo Lunar Lander</b>
<b>10 - 11</b>	<b>Comparison of LSAM &amp; Apollo Lunar Lander</b>
<b>12 - 14</b>	<b>LSAM Ascent Stage CH<sub>4</sub> Location &amp; Requirements</b>
<b>15 - 26</b>	<b>Results of Literature Search on Cryotanks</b>
<b>27 - 31</b>	<b>Prediction Weights for CH<sub>4</sub> Tanks</b>
<b>32</b>	<b>Findings-LSAM Ascent Stage CH<sub>4</sub> Tanks</b>
<b>33 - 35</b>	<b>Damage Tolerance</b>
<b>36 - 43</b>	<b>Technologies Evaluated</b>
<b>44 - 45</b>	<b>Critical Technology Barriers Solutions</b>
<b>46</b>	<b>Proposed Solutions</b>

# Exploration Timeline Offers Potential to Exploit Composites



Doug Cooke, NASA's Exploration Architecture, November 9, 2005

# Constellation Program's Lunar Surface Access Module (LSAM)





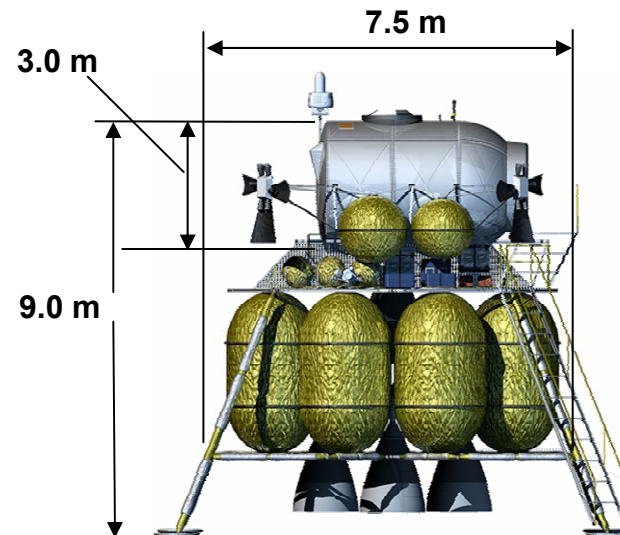


## ***Lunar Lander and Ascent Stage***

- ◆ **4 crew to and from the surface**
  - Seven days on the surface
  - Lunar outpost crew rotation
- ◆ **Global access capability**
- ◆ **Anytime return to Earth**
- ◆ **Capability to land 21 metric tons of dedicated cargo**
- ◆ **Airlock for surface activities**
- ◆ **Descent stage:**
  - Liquid oxygen / liquid hydrogen propulsion
- ◆ **Ascent stage:**
  - Liquid oxygen / liquid methane propulsion



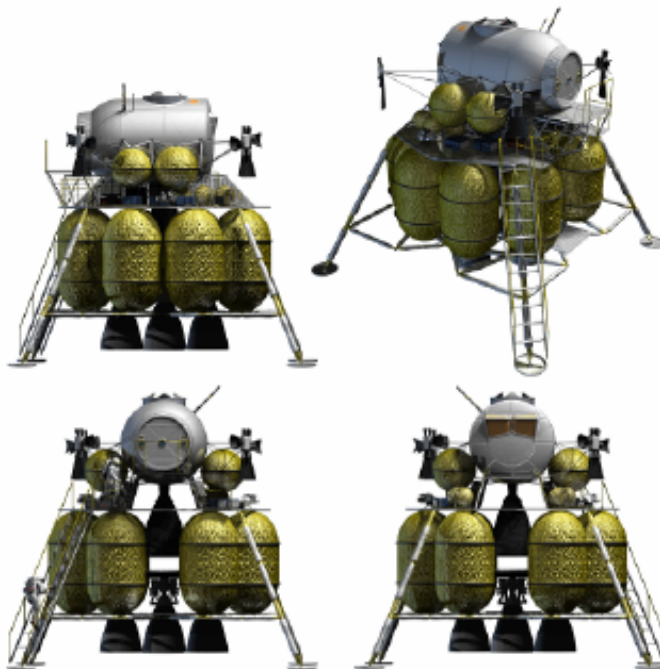
# LSAM Overall Dimensions and Payload Requirements



***Desired Payload to Surface:  
Crewed Mission ~ 6 Mt  
Cargo Mission ~ 20 Mt***

**Keith Belvin, Lunar Lander Study, Sept. 25, 2007**

# ESAS LSAM - Baseline Configuration



- ◆ **2 stage, expendable**
- ◆ **LOX/H<sub>2</sub> Descent Propulsion**
  - RL-10 derivative (x4)
  - TCMs, LOI, Deorbit, Landing
- ◆ **NTO/MMH Ascent Propulsion**
  - CEV SM derivative (x1)
  - Ascent, RNDZ, Disposal
- ◆ **Accommodations for 4 crew for 7 days on the lunar surface**
- ◆ **Full Airlock functionality**

## Vehicle Concept Characteristics

### Ascent Module Properties

1.0 Structure	
2.0 Protection	
3.0 Propulsion	
4.0 Power	
5.0 Control	
6.0 Avionics	
7.0 Environment	
8.0 Other	
9.0 Growth	
10.0 Non-Cargo	
11.0 Cargo	
12.0 Non-Propellant	
13.0 Propellant	
Dry Mass	
Inert Mass	
Total Vehicle	

Sortie Mission	
Mass (kg)	Mass (lbm)
1,147	2,524
113	249
718	1,579
1,205	2,652
0	0
385	847
1,152	2,534
382	841
1,020	2,245
153	337
0	0
173	381
6,238	13,724
6,123 kg	13,471
6,276 kg	13,807
12,687 kg	27,912

### Descent Module Properties

1.0 Structure	
2.0 Protection	
3.0 Propulsion	
4.0 Power	
5.0 Control	
6.0 Avionics	
7.0 Environment	
8.0 Other	
9.0 Growth	
10.0 Non-Cargo	
11.0 Cargo	
12.0 Non-Propellant	
13.0 Propellant	
Dry Mass	
Inert Mass	
Total Vehicle	

Sortie Mission	
Mass (kg)	Mass (lbm)
2,214	4,870
88	194
2,761	6,075
486	1,070
92	201
69	152
284	626
715	1,573
1,342	2,952
2,438	5,455
500	1,100
659	1,450
30,319	66,702
8051	17,712
11049	24,308
42027	92,459

**John Connolly, Kickin' up some dust, Feb. 20, 2007**

# Grumman Apollo LM



[Apollo 11](#) LM on lunar surface

## Dimensions

**Height:**20.9 ft6.37 m

**Diameter:**14 ft4.27 m

**Landing gear span:**29.75 ft9.07 m

**Volume:**235 ft<sup>3</sup>6.65 m<sup>3</sup>

## Masses

**Ascent module:**10,024 lb4,547 kg

**Descent module:**22,375 lb10,149 kg

**Total:**32,399 lb14,696 kg

## Rocket engines

**LM RCS (N<sub>2</sub>O<sub>4</sub>/UDMH) x 16:**100 lbf ea441 N

## Ascent Propulsion System

(N<sub>2</sub>O<sub>4</sub>/[Aerozine 50](#)) x 1:3,500 lbf ea15.6 kN

## Descent Propulsion System

(N<sub>2</sub>O<sub>4</sub>/[Aerozine 50](#)) x 1:9,982 lbf ea44.40 kN

## Performance

**Endurance:**3 days72 hours

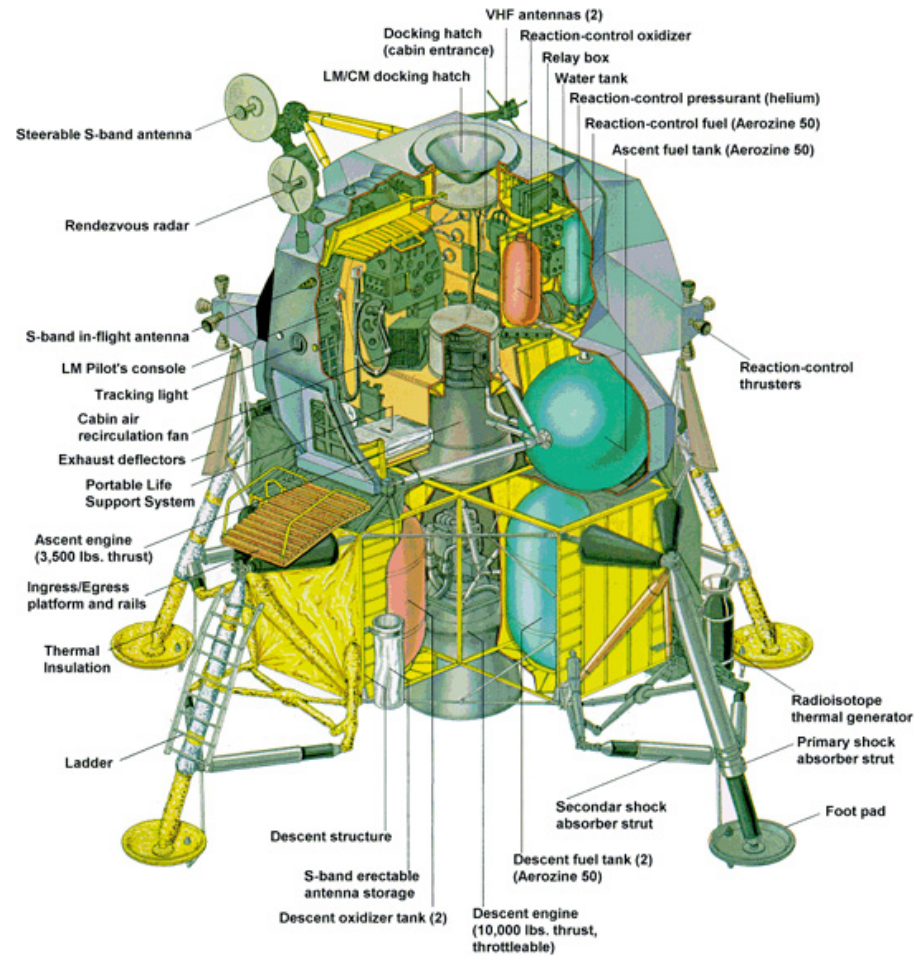
**Aposelene:**100 miles160 km

**Periselene:** surface

**Spacecraft delta v:**15,390 ft/s4,690 m/s

[http://en.wikipedia.org/wiki/Apollo\\_Lunar\\_Module](http://en.wikipedia.org/wiki/Apollo_Lunar_Module)

# Apollo Lunar Module



Reference ???

The lunar module was 23 ft. tall and had a launch weight of 33,205 lbs.  
(The Apollo 17 J-Series lunar module weighed 36,244 lbs.)



## Apollo Lunar Module (LM) compared to ESAS baseline Constellation Lunar Surface Access Module (LSAM)



	<u>Apollo LM</u>	<u>Constellation LSAM (ESAS baseline)</u>
<b>Crew Size (max)</b>	2	4
<b>Surface Duration (max)</b>	3 days	7 days (Sortie missions), Up to 210 days (Outpost missions)
<b>Landing site capability</b>	Near side, equatorial	Global
<b>Stages</b>	2	2
<b>Overall height</b>	7.04 m (23.1 ft.)	9.7 m (31.8 ft.)
<b>Width at tanks</b>	4.22 m (13.8 ft.)	7.5 m (24.6 ft.)
<b>Width at footpads (diag.)</b>	9.45 m (31 ft.)	14.8 m (48.6 ft.)
<b>Crew module pressurized volume</b>	6.65 m <sup>3</sup> (235 cu. ft)	31.8 m <sup>3</sup> (1123 cu. ft)
<b>Ascent Stage mass</b>	4805 kg (10571 lbs.)	10809 kg (23780 lbs.)
<b>Ascent Stage engines</b>	1 – UDMH-NTO	1 – LOX-CH <sub>4</sub> (under study)
<b>Ascent engine thrust</b>	15.6 Kn (3500 lbf)	44.5 Kn (10000 lbf)
<b>Descent Stage mass</b>	11666 kg (25665 lbs.)	35055 kg (77120 lbs.)
<b>Descent Stage engines</b>	1 – UDMH-NTO	4 – RL-10 derived LOX/H <sub>2</sub>
<b>Descent engine thrust</b>	44.1 Kn (9900 lbf)	4x 66.7Kn (4x 15000 lbf)

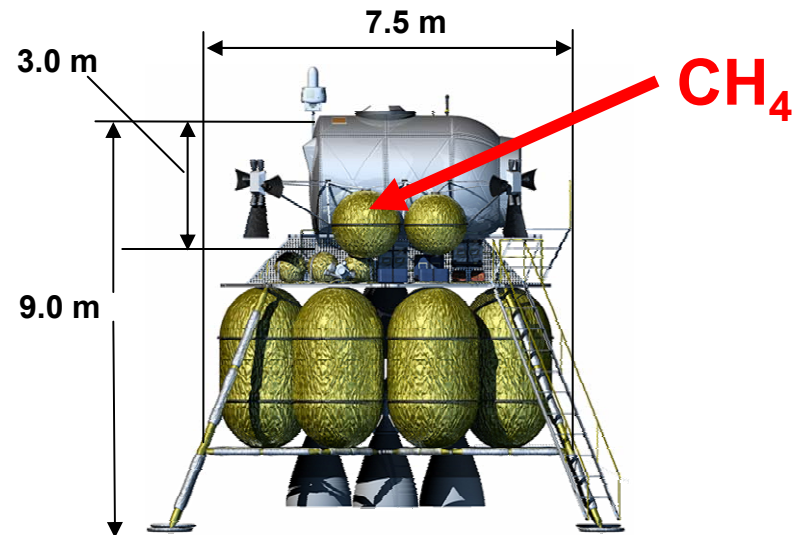
**John Connolly, Kickin' up some dust, Feb. 20, 2007**

## LSAM Much Larger and Heavier Than and Apollo 11 Lunar Modules

<u>Requirement/Characteristic</u>	<u>LSAM</u>	<u>Apollo 11</u>	<u>Ref.</u>
No. Crew to & from the Surface	4	2	1
Days on Surface	7	3	1
Height, meter	9	3.2	2
Diameter , meter	7.5	4.2	2
Landing Gear Diameter, meter	14.8	9.5	1
Descent Propulsion System	LH <sub>2</sub> O <sub>2</sub>	N <sub>2</sub> O <sub>4</sub> /Aerozine 50	1
Descent Stage Mass, lb	92,453	22,783	1
Descent Propellant Mass, lb	66,702	18,000	1
Ascent Propulsion System	LCH <sub>4</sub> O <sub>2</sub>	N <sub>2</sub> O <sub>4</sub> /Aerozine 50	1
Ascent Stage Mass, lb	27,912	10,300	1
Ascent Propellant Mass, lb	13,724	5,187	1

**References: 1. John Connolly, Kickin' up some dust, Feb. 20, 2007**  
**2. Keith Belvin, Lunar Lander Study, Sept. 25, 2007**

# LSAM Ascent Stage Propellant Tank Location





# Higher Factor of Safety Mandated

## for Composite Tanks



National Aeronautics and  
Space Administration

CxP 70135

BASELINE, CHANGE 001

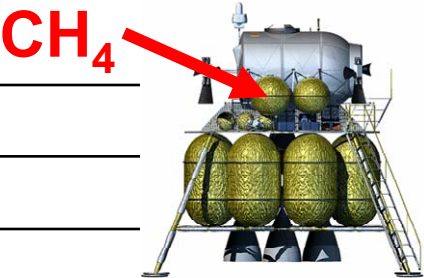
RELEASE DATE: MAY 11, 2007

### CONSTELLATION PROGRAM STRUCTURAL DESIGN AND VERIFICATION REQUIREMENTS

**Table 3.10-1 Minimum Factors of Safety for Structure**

I. Minimum Factors of Safety for Pressure	<u>Yld</u>	<u>Ult</u>
2. Pressurized Hardware (MSFC-HDBK-505B, ANSI/AIAA-S-080 and ANSI/AIAA-S-081)		
i. Metallic Propellant Tanks and Solid Rocket Motor Cases that are Pressurized Structures	1.1	1.4
Proof Pressure <sup>1</sup>	= 1.05 X MDP <sup>6</sup>	
j. Composite Propellant Tanks and Solid Rocket Motor Cases that are Pressurized Structures	N/A	1.5
Proof Pressure <sup>1</sup>	= 1.20 X MDP <sup>6</sup>	

# Design Requirements & Assumptions Used To Estimate Wt. of LSAM Ascent Stage LCH<sub>4</sub> Tanks

<u>Requirements</u>		<u>Value</u>
		
CH <sub>4</sub> Weight, lbs		<b>2745</b>
CH <sub>4</sub> Volume, ft <sup>3</sup>		<b>106</b>
Tank Diameter not to exceed, ft.		<b>5</b>
Minimum No. of Tanks Required		<b>2</b>
Pump Feed- Operating Pressure (OP), psi		<b>30</b>
Maximum acceleration, g's		<b>3.86</b>
Safety Factors (Metal 1.4, Composite 1.5)		<b>1.4/1.5</b>
Design Pressure, psi (S.F. X 3.86 X Static Head + OP)		<b>188/201</b>
<u>Assumptions</u>		
	Failure Based on Membrane Stress ( $\sigma = pr/2t$ )	
	Bending Stresses Neglected	
	Max. Allowable Stresses Based on Reference NASA TM 2007-214846	
	Only Spherical Shaped Tank Considered	
	Pump, Gauging & End Boss Weights Not Included	

# Titanium Propellant Tanks Provided For Recent Discovery Missions

PROGRAM	NEAR Fuel	NEAR Oxidizer	Lunar Prospector	Mars Surveyor '98	Mars Pathfinder
Fuel	Hydrazine	N <sub>2</sub> O <sub>4</sub> Oxidizer	Hydrazine	Hydrazine	Hydrazine
Size	22.14-inch ID, ∅	19.06-inch ID, ∅	19.23-inch ID, ∅	16.5-inch ID, ∅	16.5-inch ID, ∅
Total Volume	5555 in <sup>3</sup>	3660 in <sup>3</sup>	3775 in <sup>3</sup>	2300 in <sup>3</sup>	2300 in <sup>3</sup>
Propellant Weight	166 lbm	117 lbm	101 lbm	70.5 lbm	35 lbm
Propellant Management	Diaphragm	Vortex Suppressor	Vortex Suppressor	Diaphragm	Diaphragm
Operating Pressure	280 psi	280 psi	450 psi	450 psi	435 psi
Proof Pressure	420 psi	420 psi	1100 psi	495 psi	653 psi
Burst Pressure	560 psi	560 psi	1200 psi	675 psi	1740 psi
Operating Temperature	44 to 122 °F	44 to 122 °F	40 to 120 °F	3 to 40 °C	45 to 160 °F
Tank Weight	16.2 lbm	10.7 lbm	11.5 lbm	10.0 lbm	17 lbm
Expulsion Efficiency	≥ 99%	≥ 99%	≥ 99%	≥ 99%	≥ 99%
External Leakage	1 x 10 <sup>-6</sup> scc/sec He	1 x 10 <sup>-6</sup> scc/sec He	1 x 10 <sup>-7</sup> scc/sec He	1 x 10 <sup>-6</sup> scc/sec He	1 x 10 <sup>-6</sup> scc/sec He
Tank Material	Ti-6AL-4V	Ti-6AL-4V	Ti-6AL-4V	Ti-6AL-4V	Ti-6AL-4V
Minimum Wall	0.027 in	0.023 in	0.040 in	0.020 in	0.043 in
Acceptance Tests	Volume capacity Proof pressure Volume capacity Internal leakage External leakage X-Ray Penetrant Mass Clean	Volume capacity Proof pressure Volume capacity External leakage X-ray Penetrant Mass Clean	Volume capacity Proof pressure Volume capacity External leak X-ray Penetrant Mass Clean	Volume capacity Proof pressure Volume capacity Internal leakage External leakage X-ray Penetrant Mass Clean	Volume capacity Proof pressure Volume capacity Internal leakage External leakage X-ray Penetrant Mass Clean
Qualification Tests	None	None	None	None Protoflight test on one tank	None
Flight Heritage	TOMS, DSCS	EXOSAT	MODEL 35	ECS	Space Shuttle, P80
Modifications	Modify mounting lugs, Modify in/outlet tubes	Remove diaphragm, Remove diaphragm Retaining features, Add outlet port, Modify mounting lugs, Modify in/outlet tubes Add vortex suppressor	Modify tubes Add vortex suppressor	Modify mounting, Modify tubes	None
Non-recurring Activities	Stress & fracture mechanics analyses, Some drawings, Mfg readiness review	Stress & fracture mechanics analyses, Some drawings Mfg readiness review, Some tooling	Stress & fracture mechanics analysis, Slosh analysis, Some drawings, Some tooling	Some drawings, Some tooling	None
Qualification	By Similarity	By Similarity	By Similarity	By Similarity	Not required

Tam,W.H.,et al.

**IAA P8 Low-Cost Tankage Provided For Recent Discovery Missions. 3<sup>rd</sup> IAA International Conference on Low-Cost Planetary Missions. May 1998**

# Composite Technology Developments (CTD) Linerless Gr/Ep Vessel



Source: CTD

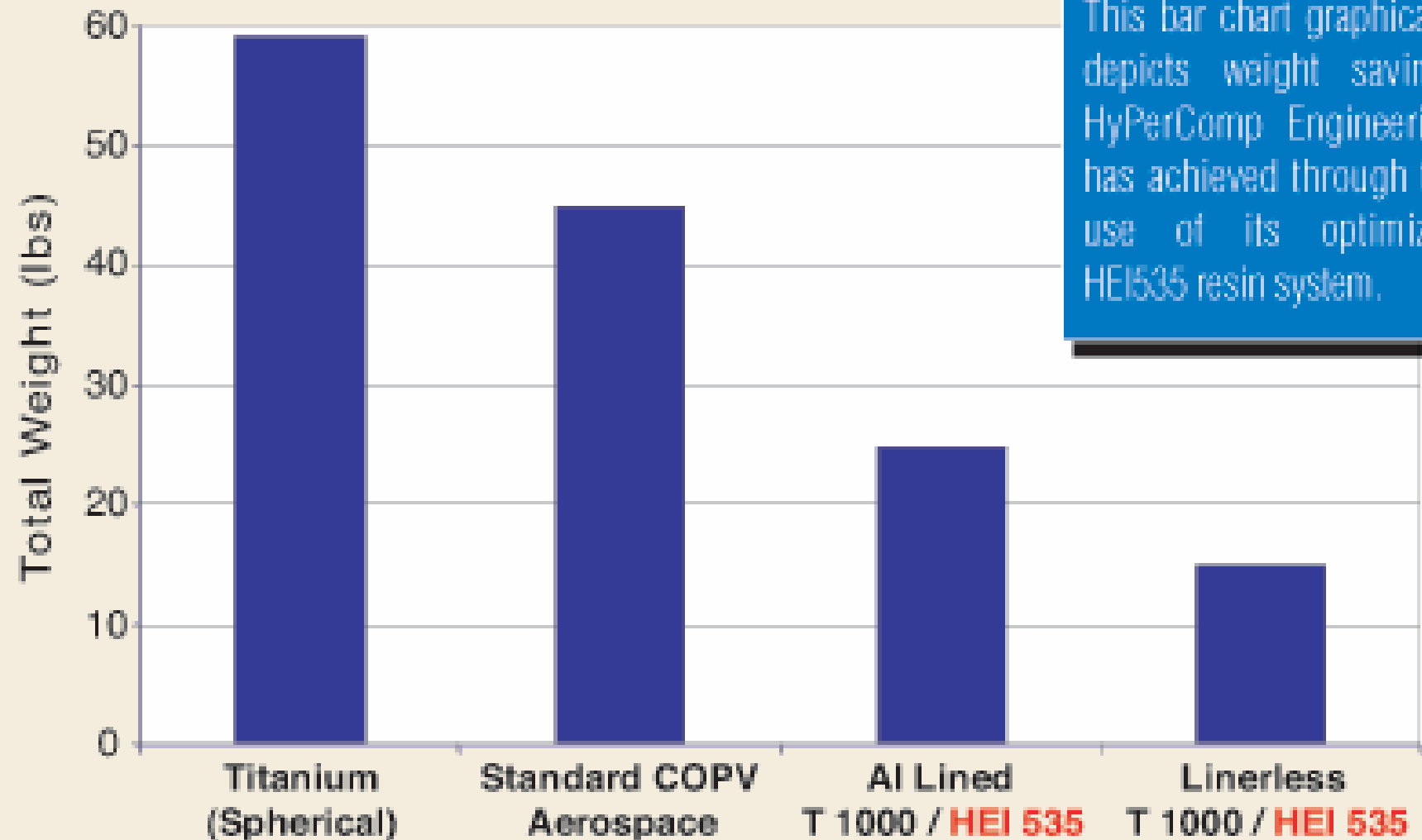
Linerless (and therefore lighter) cryogenic tanks have been a goal throughout composite pressure vessel experimentation. According to tank developer Composite Technology Developments (CTD), ultralight, linerless composite tanks (ULLCTs) may reduce vessel weight by as much as 25 percent, compared to lined tanks.

<http://www.compositesworld.com/hpc/issues/2007/March/111327>

# CRYOGENIC CYLINDRICAL TANKS

## COPV Weight Savings using **HEI 535 Resin**

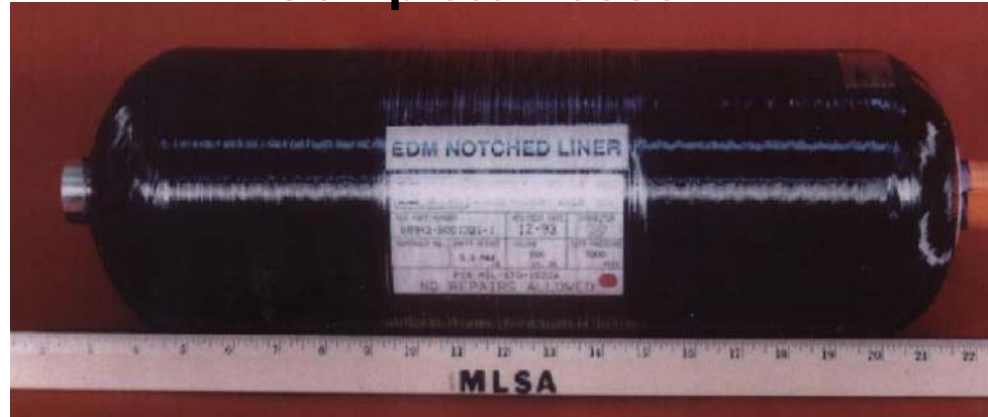
4,550 psi Service, 100 L



Source: HyPerComp Engineering

# COPV Designed to Store 7000 psi Inert gas

## Complete Vessel



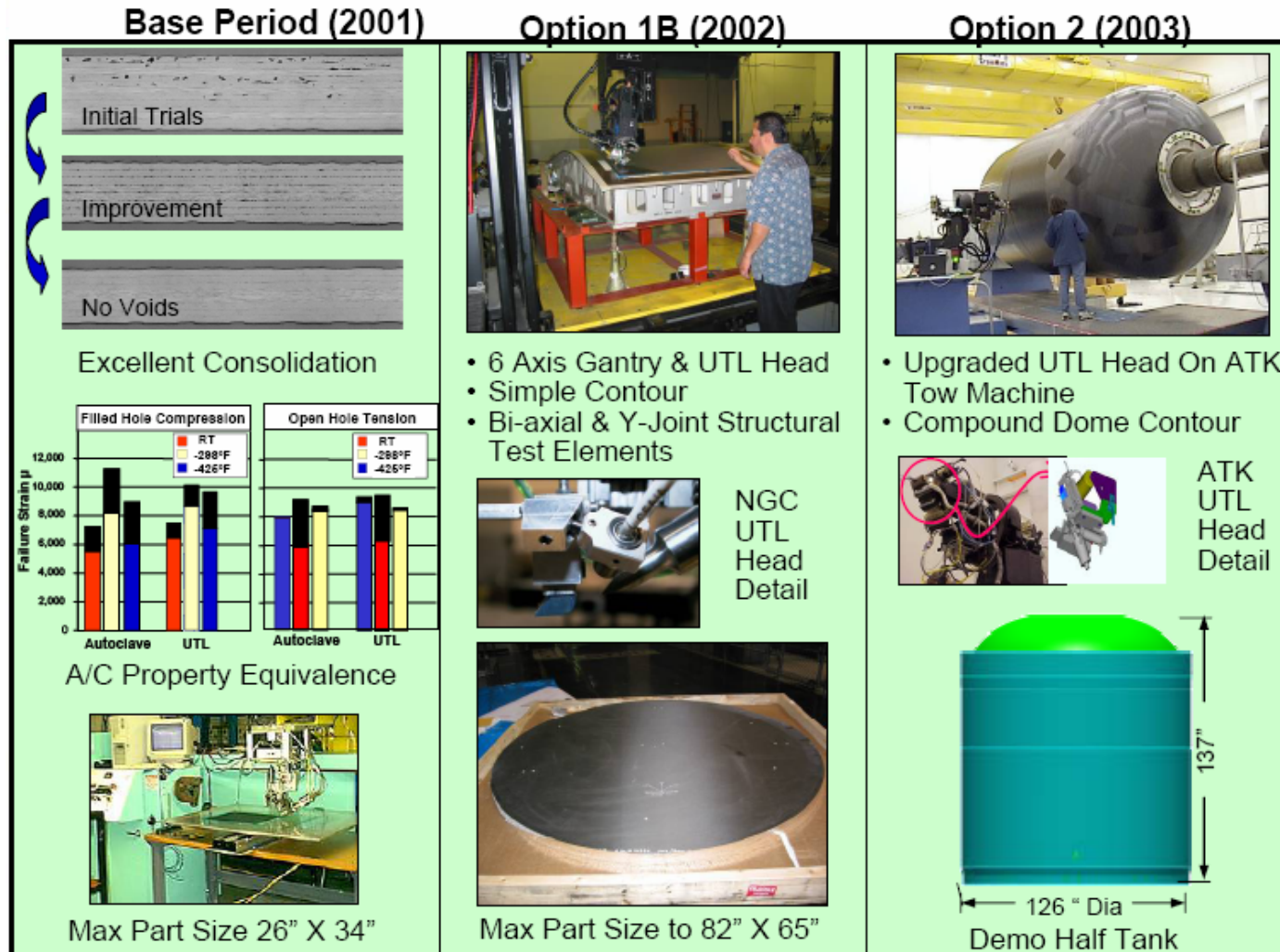
## Dome



## Center Section

Reference: Beeson, et al , NASA TP 2002-210769

# NGLT Cryotank Development & Validation by Northrop Grumman



Reference: Ravi Deo, Kickoff Meeting Talk, October 23, 2007

# Key References

1. **Arnold, Steven M, et al., Spherical Cryogenic Hydrogen Tank Preliminary Design Trade Studies. NASA Technical Memorandum-214846, October 2007.**
2. **Zimmerli, G. A., Propellant Gauging For Exploration. 54<sup>th</sup> JANNAF Propulsion Meeting, May 2007.**
3. **Orion: Composite Tanks' Ticket to Space?**  
<http://www.compositesworld.com/hpc/issues/2007/March/111327>
4. **Whitehead, David; and Wilson, Brian: Composite Boss Technology. AFRL-VS-PS-1998-1040.**
5. **HyPerComp Demonstrates High-Pressure Composite Pressure Vessels .**  
<http://www.compositesworld.com/news/cwwwweekly/2006/September/cw110659>
6. **HyPerComp Engineering Inc.; SBIR NAS8-03027 Final Report**
7. **Mital, Subodh K, et al., Review of Current State-of-the-Art and Key Design Issues With Potential Solutions for Liquid Hydrogen Cryogenic Storage Tank Structures for Aircraft. NASA Technical Memorandum 21346, October 2006.**



# Key References (Continued)

8. External Tank;  
<http://science.ksc.nasa.gov/shuttle/technology/sts-newsref/et.html>
9. Tam, W.H. ,et al; Low Cost Derivative Tanks for Spacecraft and Launch Vehicles. AIAA 99-2831, June 20-24,1999.
10. Dorsey, John T., et al., Reusable Launch Vehicle Tank/Intertank Sizing Trade Study. AIAA-2000-1043.
11. Palm, Todd E., et al.,Non-Metallic Materials and Full Scale Demo and Subscale Cryotank Development. Document No:SLI-04-1022, Volume 1, May 28,2004.
12. Structural Design and Test Factors of Safety for Spaceflight Hardware”. NASA-STD-(1)-5001A, Approved: 09-12-2006 & **Expiration Date: 09-11-2007.**

## Key References (Continued)

13. Chen, P. S.: “Cryogenic Fracture Toughness Improvement for Super Lightweight Tank’s Main Structural Alloy,” NASA Technical Memorandum 211547, February 2002.
14. Al-Li Materials Database. Service Order 89818.
15. ASM Material Data Sheet.  
<http://asm.matweb.com/search/SpecificMaterial.asp?bassnum=MTP641>
16. Methane. <http://en.wikipedia.org/wiki/Methane>
17. Liquid Methane : Praxiar Material Safety Data Sheet.
18. Liquid Oxygen: <http://www.airproducts.com/>
19. Fracture Control Requirements for Composite and Bonded Vehicle and Payload Structures. MSFC-RQMT-3479, June 29,2006.
20. Robinson, Michael J., et al., Hydrogen Permeability Requirements and Testing For Reusable Launch Vehicle Tanks, AIAA 2002-1418.

## **Key References (Continued)**

- 21. Gates, Thomas S., et al., Permeability and Life-Time Durability of Polymer Matrix Composites for Cryogenic Fuel Tanks. AIAA 2004-1859.**
- 22. Stokes, Eric H., Hydrogen Permeability of Polymer Based Composites Under Bi-Axial Strain and Cryogenic Temperatures. AIAA 2004-1858.**
- 23. Bechel, Vernon T., Permeability and Damage in Unloaded Cryogenic Cycled PMCs. AIAA 2005-2156.**
- 24. Tam, W. H., et al., Low-Cost Tankage Provided For Recent Discovery Missions. 3<sup>rd</sup> IAA International Conference on Low-Cost Planetary Missions. April 27, 1998.**
- 25. Schuerch, Hans, and Burggraf, Odus,; “Analytical Design for Optimum Filamentary Pressure Vessels” AIAA Journal, Vol 2, No 5, May 1964.**
- 26. Beeson, Harold D., et al., Composite Overwrapped Pressure Vessels. NASA TP 210768, Jan. 2002.**
- 27. Constellation Structural Design and Verification Requirements. NASA CXP 70135, May 11, 2007.**

# **Summary Results of Literature Search on Propellant Tanks**

- 1. Numerous small tanks ( largest dimension less than 3 feet) have been built and tested. Titanium, Graphite/Epoxy Over Wrapped Titanium Liner, and Graphite/Epoxy (Gr/Ep) are materials most often cited. Significant R&D in high pressure tanks for ground transportation vehicles has been conducted.**
- 2. Larger tanks have been design and built using Gr/Ep. Notable examples include: Next Generation Launch Technology (NGLT), National Aerospace Plane, and X-33. The NGLT tank was 6 feet in diameter by 15 feet long.**
- 3. The Space Shuttle Orbiter LiAl 2195 LH<sub>2</sub> tank is considered to be a baseline for comparing new large tank concepts.**
- 4. Liquids and Gases Include: H<sub>2</sub>, O<sub>2</sub>, CH<sub>4</sub>, N<sub>2</sub>H<sub>4</sub>, N<sub>2</sub>H<sub>4</sub>/UDMH**
- 5. Most tanks are circular in cross section. Exceptions are due to space available constraints in the vehicle.**

# **Summary Results of Literature Search on Propellant Tanks (Continued)**

- 6. Methods for estimating weight range from first principle membrane stress calculations to very detailed finite element structural analyses.**
- 7. Cost prediction methods, especially for large tanks are less mature than structural analyses.**
- 8. NASA and ANSI/AIAA Technical Standards has been developed and include requirements on pressure containment, mechanical and/or thermal proof tests, leakage, and propellant loss from external heating. (NASA CXP 70135, NASA-STD-(I)-5001A, MSFC-RQMT-3479, ANSI S-080, and ANSI S-081)**
- 9. NASA TM 2006-214346 reviews State-of-the-Art & Key Design Issues With Potential Solutions for LH2 Cryogenic Storage Tank Structures For Aircraft Applications. The NGLT tank is representative of State-of-the-Art.**
- 10. Composite structures are required to meet higher factors of safety than metal (NASA-STD-(I)-5001A, pg18)**

# Composites Structures Must Meet Larger Ultimate Design Factor

NASA-STD-(I)-5001A

Table 3—Minimum Design and Test Factors for Composite/Bonded Structures

Verification Approach	Geometry of Structure	Ultimate Design Factor	Qualification Test Factor	Acceptance or Proof Test Factor
Prototype	Discontinuities**	2.0*	1.4	1.05
	Uniform Material	1.4	1.4	1.05
Protoflight	Discontinuities**	2.0*	NA	1.2
	Uniform Material	1.5	NA	1.2

**NOTE:**

- \* Factor applies to concentrated stresses. For non-safety critical applications, this factor may be reduced to 1.4 for prototype structures and 1.5 for protoflight structures.
- \*\* Discontinuities are defined as an interruption in the physical structure or configuration of the part. Delaminations, debonds, and dropping of plies are all assumed to be discontinuities.

**In Compliance with NASA CXP 70135, a Design Ultimate Safety Factor (S.F.) of 1.5 was used to predict weight of CH<sub>4</sub> tanks. Question: Do composites tanks have to take an addition knockdown factor? If the ratio of (2.0/1.4) is multiplied by UDF, the penalized for ply drop off would be 42%!**

# Structural Concepts Evaluated

## For LSAM Ascent Stage LCH<sub>4</sub> Tanks

<b>Wall Material</b>	<b>Liner</b>	<b>Fabrication Process</b>	<b>Data Reference</b>
<b>IM7/977-2</b>	<b>None</b>	<b>Tow Place or Filament Wind</b>	<b>NASA TM-2007-214846</b>
<b>COPV IM7/977-2</b>	<b>LiAl 2090</b>	<b>Tow Place or Filament Wind</b>	<b>NASA TM-2007-214846</b>
<b>LiAl 2195</b>	<b>None</b>	<b>Weld</b>	<b>NASA TM-2007-214846</b>
<b>Ti 6Al 4V</b>	<b>None</b>	<b>Weld</b>	<b>NASA TM-2007-214846</b>
<b>Al 2024</b>	<b>None</b>	<b>Weld</b>	<b>NASA TM-2007-214846</b>

# Assumptions Used To Estimate Weight of LSAM Ascent Stage LCH<sub>4</sub> Tanks

<b>Assumption</b>	
	<b>Failure Based on Membrane Stresses, only</b>
	<b>Bending Stresses Neglected</b>
	<b>Maximum Allowable Stresses Based on References</b>
	<b>Safety Factor = 1.5(Metal) &amp; 1.4(Composite)</b>
	<b>Environmental Effects Neglected</b>
	<b>Only Spherical Shaped Tank Considered</b>
	<b>Membrane Stress = <math>pr/2t</math></b>
	<b>Pump, Gauging and End Boss Weights Not Included</b>

**See Note.**



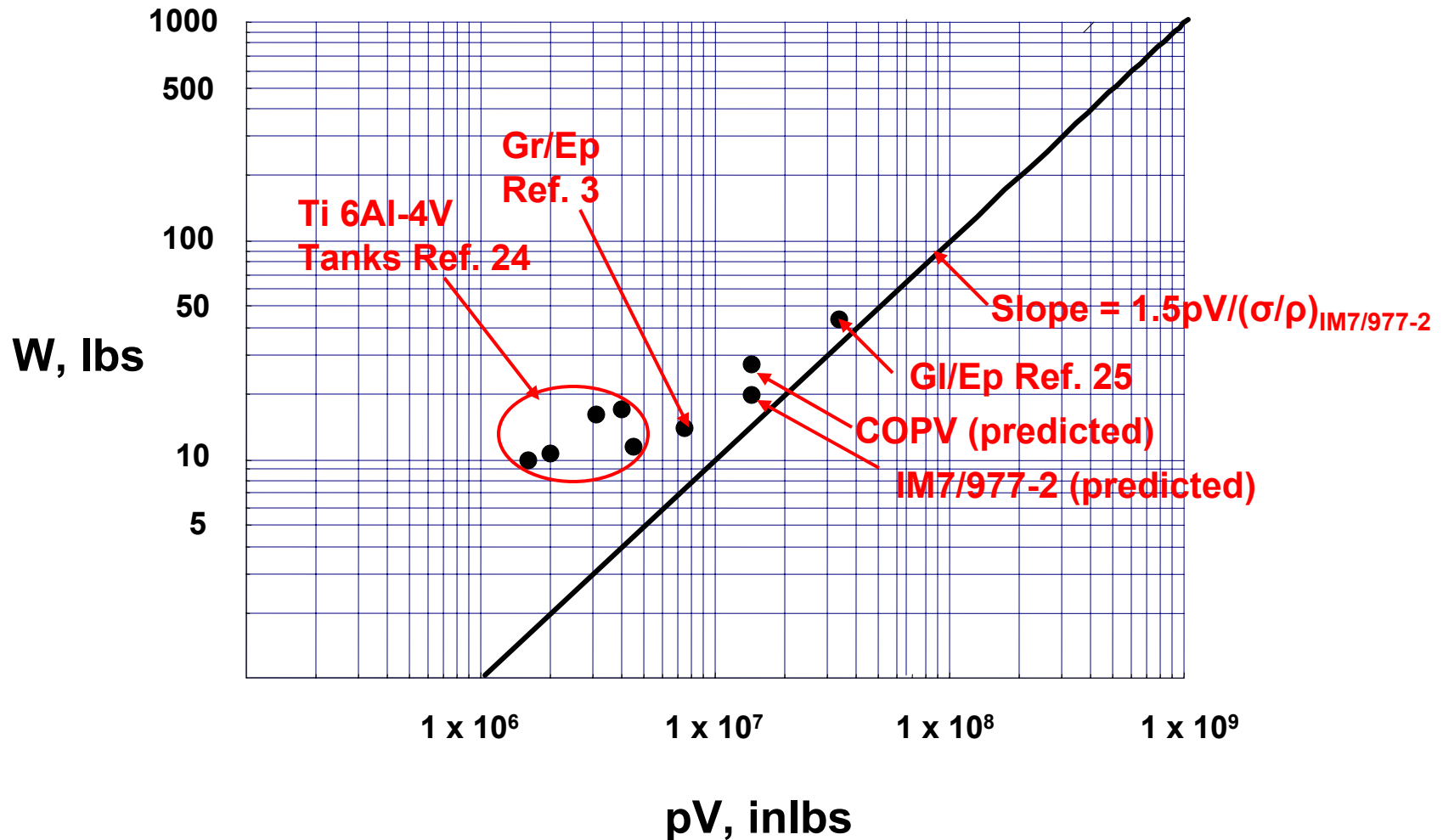
## Composite Offers Significant Weight Savings

<u>Tank Material</u>	<u>Gr/Ep</u> <u>IM7/977-2</u>	<u>COPV</u>	<u>LiAl</u> <u>2195</u>	<u>Ti</u> <u>6Al-4V</u>	<u>Al</u> <u>2024</u>
<u>Item</u>					
Propellant Weight,lbs	2745	2745	2745	2745	2745
Propellant Density, lbs/cu.ft.	25.91	25.91	25.91	25.91	25.91
Maximum Design Pressure,psi	201	201	188	188	188
Allowable Stress, psi	82000	59000	78000	128000	67000
Wall Material Density,lbs/in <sup>3</sup>	0.0570	0.0606	0.0975	0.1600	0.1100
Number of Tanks	2	2	2	2	2
Total Volume, cu.ft.	105.94	105.94	105.94	105.94	105.94
Volume of Each Tank, cu.ft.	52.97	52.97	52.97	52.97	52.97
Tank Radius, ft.	2.94	2.94	2.94	2.94	2.94
Tank Wall Thickness, in.	0.034	0.047	0.034	0.021	0.039
Tank Weight, lbs	19.21	28.37	32.25	32.25	42.35
Percent Weight Reduction	-40%	-12%	0%	0%	31%

## Summary Comparison of Concepts Evaluated for LSAM Ascent Stage LCH<sub>4</sub> Tanks

<u>Concept</u>	<u>Materials</u>	<u>Fabrication</u>	<u>Critical Design Requirement</u>	<u>Weight Lbs</u>
<b>Baseline</b>	<b>LiAl 2195</b>	<b>WELD</b>	<b>Burst/Fracture</b>	<b>32.25</b>
<b>COPV liner LiAl 2090</b>	<b>IM7/977-2</b>	<b>Tow Place or Filament Wind</b>	<b>Burst/Fracture &amp; Damage Tolerance</b>	<b>28.37</b>
<b>Composite No liner</b>	<b>IM7/977-2</b>	<b>Tow Place or Filament Wind</b>	<b>Burst/Fracture &amp; Damage Tolerance</b>	<b>19.21</b>

# Comparison of Tank Weights With Predicted Theoretical Minimum Weight For Spherical Tank



# Findings for LSAM Ascent Stage LCH<sub>4</sub> Tanks

- 1. An all composite walled tank offers the potential to reduce weight by approximately 40% compared to a LiAl 2195 tank.**
- 2. A composite over wrapped LiAl 2090 liner tank offers the potential to reduce weight by approximately 12% compared to a LiAl 2195 tank.**
- 3. LiAl 2195 and Ti 6Al-4V tanks are predicted to have equal weights.**
- 4. Weights were based on allowable properties for IM7/977-2 and more information is need to dismiss or address the potential for microcracking. T1000/HEI 535 is reported to have improved toughness at cryogenic temperatures and is a potential candidate replacement matrix.**
- 5. Concern for damage tolerance due to handling must be addressed.**
- 6. Minimum gage based on handling and MMOD must be established.**
- 7. Tank size and configuration is such that fabrication is possible with tow placement and or filament winding and autoclave curing.**

# Damage Tolerance for LSAM Ascent Module **Liquid CH<sub>4</sub> Propellant Tank**

1. **What are the threats? (MMOD Impact, Ground Handling.)**  
**Advancements - Improved environmental models for Micrometeoroid debris, LDEF data, hypervelocity impact date phenomena**
2. **What is the nature of potential damage from threats? (Visible penetrations, delaminations and/or microcracking.)** **Improved toughness materials offer robustness to impact and microcracking damage initiation and propagation which has lead to leaks in past applications.**
3. **How is non visible damage detected? (Based on expected wall thickness and vessel size, any damage to the tank after manufacturing is expected to be visible.)** **Significant advances in thermography and shearography and other NDE methods have been made in recent years. Damage can be detect damage in the “as fabricated tank”. Microcrack detection ??**

Note: In some charts, “??” appear and indicate that potential ideas or data were being sought but not completed due to time and budget constraints

# **Damage Tolerance for LSAM Ascent Module**

## **Liquid CH4 Propellant Tank (Continued)**

4. **What are the potential failure modes for the tank? (Debond of attachments, leaks and burst.) Insitu health monitoring provides capability to detect anomalies before critical damage size and/or load levels are reached.**
5. **How is damage growth and failure predicted? (Detailed finite element model analyses can predict crack initiation, crack growth and residual strength??)**
6. **What is the fidelity of damage growth and failure analyses? (Recent R&D by ??? Have shown the ability to predict crack initiation, crack growth and residual strength for ?? within ??? %.)**
7. **What is the heritage of composite propellant tanks? (Composite tanks ranging in size from ?? to ?? and pressures from ?? to ?? have flown. Composite tanks ranging in size from ?? to ?? and pressures from ?? to ?? have been ground tested.)**

## **Damage Tolerance for LSAM Ascent Module Liquid CH4 Propellant Tank (Continued)**

- 8. Are factor of safety/knockdown factor influenced by current state-of-the-art? (Design ultimate safety factors of 1.5 on the maximum internal pressure and 1.5 other loads is customary for metallic tanks. NASA STD (I) 5001A defines a ply drop off as a discontinuity and imposed a design ultimate safety factor of 2.0 for all applications.**
- 9. How can concerns be mitigated? Design, build and test a full scale tank. Validate analysis, NDE methods , health monitoring and damage tolerance capability.**

# List of Technologies - Input Data

	A	B	C	D	E	F	G	H
1	<b>Composites Technologies Considered For</b>							
2	See Definitions at Bottom of Work Sheet			Potential Weight Saving Score		2Bb3 LSAM/Ascent Stage/Propellant Tanks/No Liner Comp		
3				30		Davis, John		
4						Enter Four Digit Constellation Element Identification Code and Name of structural element/structural concept( For Example - 2Bb1 - LSAM/Ascent Module/Propellant Tanks/COPV)		
5						Enter Your Name (Last, First)		
6	Level of Technology Development Required	Degree of Importance	Degree of Difficulty	Product of Importance and Difficulty	Weighted Score	Generate Filtered Data		
7	(NR,ND,R&D)	(H=3,M=2,L=1)	(L=3,M=2,H=1)					
8								
9								
10								
11						<b>1 Materials and Processes</b>		
12	R&D	3	3	9	270	1.1	Materials for cryo applications for fuel containment (e.g., microcracking, permeability, durability and insulation)	
13	ND	2	3	6	180	1.2	Surface preparation and bonding processes for improved adhesive joints	
14	R&D	3	2	6	180	1.3	Bonded joining concepts, e.g. pi-joints	
15	ND	2	3	6	180	1.4	Co-cure, co-bond, and secondary bond process characterization for repeatable production of bonded structures	
16	NR					1.5	Establish equivalence of out-of-autoclave cure processes by detailed screening, and characterization	
17	NR					1.6	Advanced non-autoclave cure methods	
18	NR					1.7	Long out-time/Long shelf-life materials	
19	NR					1.8	Nanocomposite development	
20	NR					1.9	Metal matrix, hybrid, carbon-carbon and ceramics composites	
21						<b>2 Manufacturing Methods</b>		
22	NR					2.1	Develop improved non-autoclave processes for traditional carbon/resin systems	
23	NR					2.2	Scale up of manufacturing methods to large (33-ft dia) structures	
24	NR					2.3	Manufacturing technologies for large scale structures, e.g., tape/tow/broadgoods placement machines for very high laydown rates	
25	NR					2.4	Develop methodology to address large moments of inertia, stability and structural rigidity of rotating tools for large structures	
26	NR					2.5	Vented core and core splicing technology development	
27	ND	2	2	4	120	2.6	In-process inspection techniques and acceptance methodology	
28	NR					2.7	Nontraditional cure methods such as ultrasonics	
29	ND	1	2	2	60	2.8	Low-cost tooling	
30	ND	2	2	4	120	2.9	Improved assembly process such as self-tooling, reducing imperfections and guaranteeing adequate tolerance	



## List of Technologies - Input Data

	A	B	C	D	E	F	G	H
1	<b>Composites Technologies Considered For</b>							
2	See Definitions at Bottom of Work Sheet			Potential Weight Saving Score		2Bb3 LSAM/Ascent Stage/Propellant Tanks/No Liner Comp		
3				30		Davis, John		
4								
5								
6	Level of Technology Development Required	Degree of Importance	Degree of Difficulty	Product of Importance and Difficulty	Weighted Score	Enter Four Digit Constellation Element Identification Code and Name of structural element/structural concept( For Example - 2Bb1 - LSAM/Ascent Module/Propellant Tanks/COPV)		Enter Your Name (Last, First)
7	(NR,ND,R&D)	(H=3,M=2,L=1)	(L=3,M=2,H=1)					Generate Filtered Data
8								
9								
10								
31						3 Innovative Design		
32	NR					3.1	Efficient bolted or bonded joints between large sections	
33	R&D	2	2	4	120	3.2	Multifunctional designs (strength, thermal, radiation, acoustic, ...)	
34	ND	1	2	2	60	3.3	Sandwich Designs	
35	ND	1	1	1	30	3.4	Iso-, Ortho-Grid Stiffened Designs, selective reinforcement	
36	NR					3.5	Hybrid (metal/Composite) stiffened structures	
37	NR					3.6	Truss Structures	
38	ND	2	2	4	120	3.7	Tailored (tow steered, variable stiffness) composites	
39	ND	2	2	4	120	3.8	Primarily Bonded structures	
40	NR					3.9	Stitched Designs	
41	R&D	3	3	9	270	3.10	Point load introduction	
42	NR					3.11	Inflatables	
43	ND	3	2	6	180	3.12	In-space/ground repair methods	
44	NR					3.13	Nanocomposites for load bearing applications and reduce damage growth	
45	NR					3.14	Nanocomposites for non-load bearing applications such as electrical, IVHM, thermal	
46	NR					3.15	Very high temperature capability as needed for engines and on reentry	
47	NR					3.16	Composite overwrap pressure vessels	
48	ND	2	2	4	120	3.17	Crashworthiness incorporated in design	
49	R&D	3	2	6	180	3.18	Interaction between components (acoustics issues, payload...)	
50	ND	2	2	4	120	3.19	Integrated TPS, radiation protection	
51	ND	2	2	4	120	3.20	Methods of preventing damage growth	
52	ND	2	2	4	120	3.21	Lightweight mechanisms for load transfer	
53	NR					3.22	Engine components like nozzles and pumps	

# List of Technologies - Input Data

	A	B	C	D	E	F	G	H				
1	<b>Composites Technologies Considered For</b>											
2	See Definitions at Bottom of Work Sheet				Potential Weight Saving Score	2Bb3 LSAM/Ascent Stage/Propellant Tanks/No Liner Comp						
3					30	Davis, John						
4												
5												
6	Level of Technology Development Required (NR,ND,R&D)	Degree of Importance (H=3,M=2,L=1)	Degree of Difficulty (L=3,M=2,H=1)	Product of Importance and Difficulty	Weighted Score	Enter Four Digit Constellation Element Identification Code and Name of structural element/structural concept( For Example - 2Bb1 - LSAM/Ascent Module/Propellant Tanks/COPV)		Enter Your Name (Last, First)				
7												
8												
9												Generate Filtered Data
10												
54	<b>4 Advanced Analysis, Modeling and Simulation</b>											
55	ND	2	2	4	120	4.1	Advanced analysis for composite shell structures considering imperfections, failure mechanisms					
56	ND	2	2	4	120	4.2	Design methodology for stiffener terminations and other discontinuities					
57	ND	2	2	4	120	4.3	Effects of defects in novel design concepts, e.g., missing stitches, local debonds, porosity					
58	NR					4.4	Improved methods of analyzing highly tailored composites					
59	NR					4.5	Simulated test and evaluation of structural designs					
60	R&D	3	3	9	270	4.6	Thermo-structural design, e.g., thermally compliant joints					
61	R&D	3	3	9	270	4.7	Failure mechanism/prediction at RT and at extreme temperatures					
62	R&D	2	1	2	60	4.8	Optimization methods					
63	NR					4.10	Fatigue/life prediction					
64	R&D	2	1	2	60	4.11	Probabilistic design					
65	R&D	2	1	2	60	4.12	Progressive failure methods					
66	R&D	2	1	2	60	4.13	Hierarchical analysis					
67	R&D	2	1	2	60	4.14	Prediction of internal and residual stresses and design to minimize or take advantage of such stresses					
68	NR					4.15	Scaling and validation					
69	R&D	2	1	2	60	4.16	Coupled Loads analysis					
70	<b>5 Design Criteria and Allowables</b>											
71	R&D	3	3	9	270	5.1	Define damage tolerance requirements					
72	NR					5.2	Radiation Protection					
73	ND	2	2	4	120	5.3	MMOD Resistant Design					
74	ND	3	3	9	270	5.4	Standardized Allowables such as MIL-HDBK-17 modifications					
75	ND	3	3	9	270	5.5	In-Space durability and environmental influence on design					
76	R&D	3	1	3	90	5.6	Develop and justify less conservative knockdown factors					
77	R&D	3	1	3	90	5.7	Develop and justify more reasonable safety factors based on aircraft approach					
78	ND	2	2	4	120	5.8	Develop NDE standards					
79	R&D	3	3	9	270	5.9	Better understand and refine minimum gage specifications					
80	R&D	2	1	2	60	5.10	Develop database for better understanding of damage					

## List of Technologies - Input Data

	A	B	C	D	E	F	G	H
1	<b>Composites Technologies Considered For</b>							
2	See Definitions at Bottom of Work Sheet				Potential Weight Saving Score	2Bb3 LSAM/Ascent Stage/Propellant Tanks/No Liner Comp		
3					30	Davis, John		
4						<div style="border: 1px solid red; padding: 5px; display: inline-block;">                     Enter Four Digit Constellation Element Identification Code and Name of structural element/structural concept( For Example - 2Bb1 - LSAM/Ascent Module/Propellant Tanks/COPV)                 </div> <div style="border: 1px solid blue; padding: 5px; display: inline-block; margin-left: 20px;">                     Enter Your Name (Last, First)                 </div>		
5								
6	Level of Technology Development Required	Degree of Importance	Degree of Difficulty	Product of Importance and Difficulty	Weighted Score	<input type="button" value="Generate Filtered Data"/>		
7	(NR,ND,R&D)	(H=3,M=2,L=1)	(L=3,M=2,H=1)					
8								
9								
10								
81						6 Development, Quality Assurance and Certification		
82	ND	2	2	4	120	6.1	Inspection Methods	
83	R&D	2	1	2	60	6.2	QA to Structural Performance Correlation	
84	R&D	2	1	2	60	6.3	Post-Damage Reliability Prediction	
85	R&D	2	1	2	60	6.4	Structural health monitoring, diagnostics, and prognostics	
86	R&D	2	1	2	60	6.5	Establish Minimum complexity for design hot spot interrogation	
87	NR					6.6	Identify smallest test scale where full environmental (including in-space) simulation is required	
88	R&D	1	1	1	30	6.7	Establish level of certification that can be accomplished by analysis	
89	R&D	1	1	1	30	6.8	Increased reliance on simulation rather than testing for certification	
90	R&D	1	1	1	30	6.9	Reducing development cost	
91	NR					6.10	Improved test methods	
92	ND	2	2	4	120	6.11	Database development	
93	NR					6.12	Accelerated Aging and accelerated test methods	
94						7 Threat and Environment		
95	R&D	3	3	9	270	7.1	MMOD protection (lunar/IEO)	
96	NR					7.2	Lunar dust impacts	
97	ND	2	2	4	120	7.3	Improved leak detection	
98	NR					7.4	Aging in lunar environment	
99	ND	2	2	4	120	7.5	Static charge issues (on Earth or Moon)	
100	ND	3	3	9	270	7.6	Lunar polar extreme temperature fluctuations	
101	NR					7.7	Radiation hardened structures	
102	NR					7.8	Noise, insulation	
103	ND	2	2	4	120	7.9	Coatings and sealants	
104	ND	2	2	4	120	7.10	Toxicity including outgassing	
105								

# List of Technologies - Input Data

1	A	B	C	D	E	F	G	H
1	<b>Composites Technologies Considered For</b>							
2	See Definitions at Bottom of Work Sheet				Potential Weight Saving Score	2Bb3 LSAM/Ascent Stage/Propellant Tanks/No Liner Comp		
3					30	Davis, John		
4						Enter Four Digit Constellation Element Identification Code and Name of structural element/structural concept( For Example - 2Bb1 - LSAM/Ascent Module/Propellant Tanks/COPV)		
5						Enter Your Name (Last, First)		
6	Level of Technology Development Required	Degree of Importance	Degree of Difficulty	Product of Importance and Difficulty	Weighted Score			
7						Generate Filtered Data		
8	(NR,ND,R&D)	(H=3,M=2,L=1)	(L=3,M=2,H=1)					
9								
10								
106								
107								
108								
109	Definitions							
110	Level of Technology Development Required							
111		NR	Research in this technology area is sufficiently mature or not applicable to the type of structural element under consideration					
112		ND	Normal engineering, development and validation in this technology area are expected to solve any issues related to the type of structural element under consideration.					
113		R&D	Significant research and development are required in this technology area to solve issues related to the type of structural element under consideration.					
114	Degree of Importance							
115		H = 3	Early resolution critical to structural concept and/or meeting schedule					
116		M = 2	Has a quantifiable first order relationship to weight savings					
117		L = 1	Has a second order relationship to weight savings					
118	Degree of Difficulty							
119		L = 3	Low - Potential solutions to barriers for this technology area are <u>known</u> , potential for meeting Constellation Program schedule dates is <u>high</u> , cost and other resources are <u>modest</u> (Technology Readiness Level 5-7)					
120		M = 2	Moderate - Potential solutions to barriers for this technology area are <u>known</u> , potential for meeting Constellation Program schedule dates is <u>low to moderate</u> , cost and other resources are <u>modest to expensive</u> (Technology Readiness Level 4-6)					
121		H = 1	High - Potential solutions to barriers for this technology area are <u>ideas to known</u> , potential for meeting Constellation Program schedule dates is <u>questionable to low</u> , cost and other resources are <u>unknown to expensive</u> (Technology Readiness Level 3-5)					
122								
123	Weighted Score = Product of Degree of Importance times Degree of Difficulty and the Potential Weight Saving Score							

## List of Technologies Requiring R and D

	A	B	C	D	E	F	G	H
1	<b>Composites Technologies Considered For</b>							
2	See Definitions at Bottom of Work Sheet			Potential Weight Saving Score		2Bb3 LSAM/Ascent Stage/Propellant Tanks/No Liner Compo		
3				30		Davis, John		
4						Enter Four Digit Constellation Element Identification Code and Name of structural element/structural concept( For Example - 2Bb1 - LSAM/Ascent Module/Propellant Tanks/COPV)		
5						Enter Your Name (Last, First)		
6	Level of Technology Development Required	Degree of Importance	Degree of Difficulty	Product of Importance and Difficulty	Weighted Score			
7								
8								
9								
10	(NR,ND,R&D)	(H=3,M=2,L=1)	(L=3,M=2,H=1)					
11	<b>1 Materials and Processes</b>							
12	R&D	3	3	9	270	1.1	Materials for cryo applications for fuel containment (e.g., microcracking, permeability, durability and insulation)	
13	R&D	3	2	6	180	1.3	Bonded joining concepts, e.g. pi-joints	
14	<b>2 Manufacturing Methods</b>							
15	<b>3 Innovative Design</b>							
16	R&D	2	2	4	120	3.2	Multifunctional designs (strength, thermal, radiation, acoustic, ...)	
17	R&D	3	3	9	270	3.10	Point load introduction	
18	R&D	3	2	6	180	3.18	Interaction between components (acoustics issues, payload...)	
19	<b>4 Advanced Analysis, Modeling and Simulation</b>							
20	R&D	3	3	9	270	4.6	Thermo-structural design, e.g., thermally compliant joints	
21	R&D	3	3	9	270	4.7	Failure mechanism/prediction at RT and at extreme temperatures	
22	R&D	2	1	2	60	4.8	Optimization methods	
23	R&D	2	1	2	60	4.11	Probabilistic design	
24	R&D	2	1	2	60	4.12	Progressive failure methods	
25	R&D	2	1	2	60	4.13	Hierarchical analysis	
26	R&D	2	1	2	60	4.14	Prediction of internal and residual stresses and design to minimize or take advantage of such stresses	
27	R&D	2	1	2	60	4.16	Coupled Loads analysis	
28	<b>5 Design Criteria and Allowables</b>							
29	R&D	3	3	9	270	5.1	Define damage tolerance requirements	
30	R&D	3	1	3	90	5.6	Develop and justify less conservative knockdown factors	
31	R&D	3	1	3	90	5.7	Develop and justify more reasonable safety factors based on aircraft approach	
32	R&D	3	3	9	270	5.9	Better understand and refine minimum gage specifications	
33	R&D	2	1	2	60	5.10	Develop database for better understanding of damage	

## List of Technologies Requiring R and D

	A	B	C	D	E	F	G	H
1	<b>Composites Technologies Considered For</b>							
2	See Definitions at Bottom of Work Sheet					Potential Weight Saving Score		2Bb3 LSAM/Ascent Stage/Propellant Tanks/No Liner Compo
3						30		Davis, John
4								
5								
6	Level of Technology Development Required	Degree of Importance	Degree of Difficulty	Product of Importance and Difficulty	Weighted Score	Enter Four Digit Constellation Element Identification Code and Name of structural element/structural concept( For Example - 2Bb1 - LSAM/Ascent Module/Propellant Tanks/COPV)		Enter Your Name (Last, First)
7								
8								
9								
10	(NR,ND,R&D)	(H=3,M=2,L=1)	(L=3,M=2,H=1)					
34	<b>6 Development, Quality Assurance and Certification</b>							
35	R&D	2	1	2	60	6.2		QA to Structural Performance Correlation
36	R&D	2	1	2	60	6.3		Post-Damage Reliability Prediction
37	R&D	2	1	2	60	6.4		Structural health monitoring, diagnostics, and prognostics
38	R&D	2	1	2	60	6.5		Establish Minimum complexity for design hot spot interrogation
39	R&D	1	1	1	30	6.7		Establish level of certification that can be accomplished by analysis
40	R&D	1	1	1	30	6.8		Increased reliance on simulation rather than testing for certification
41	R&D	1	1	1	30	6.9		Reducing development cost
42	<b>7 Threat and Environment</b>							
43	R&D	3	3	9	270	7.1		MMOD protection (lunar/IEO)

# List of Highest Score Technologies Requiring R and D

A	B	C	D	E	F	G	H
1	<b>Composites Technologies Considered For</b>						
2	See Definitions at Bottom of Work Sheet			Potential Weight Saving Score		2Bb3 LSAM/Ascent Stage/Propellant Tanks/No Liner Comp	
3				30		Davis, John	
4						Enter Your Name (Last, First)	
5						Enter Four Digit Constellation Element Identification Code and Name of structural element/structural concept( For Example - 2Bb1 - LSAM/Ascent Module/Propellant Tanks/COPV)	
6	<b>Level of Technology Development Required</b>	<b>Degree of Importance</b>	<b>Degree of Difficulty</b>	<b>Product of Importance and Difficulty</b>	<b>Weighted Score</b>		
7	(NR,ND,R&D)	(H=3,M=2,L=1)	(L=3,M=2,H=1)				
8						<b>1 Materials and Processes</b>	
9						1.1	Materials for cryo applications for fuel containment (e.g., microcracking, permeability, durability and insulation)
10	R&D	3	3	9	270	<b>2 Manufacturing Methods</b>	
11						<b>3 Innovative Design</b>	
12						3.10	Point load introduction
13						<b>4 Advanced Analysis, Modeling and Simulation</b>	
14	R&D	3	3	9	270	4.6	Thermo-structural design, e.g., thermally compliant joints
15						4.7	Failure mechanism/prediction at RT and at extreme temperatures
16						<b>5 Design Criteria and Allowables</b>	
17	R&D	3	3	9	270	5.1	Define damage tolerance requirements
18	R&D	3	3	9	270	5.9	Better understand and refine minimum gage specifications
19						<b>6 Development, Quality Assurance and Certification</b>	
20						<b>7 Threat and Environment</b>	
21						7.1	MMOD protection (lunar/IEO)
22							
23							
24	R&D	3	3	9	270		

# **Technology Barrier Issues for LSAM Ascent Stage LCH<sub>4</sub> Tanks Based on Spreadsheet Scoring**

## **Highest Scoring Technologies Requiring R & D**

- 1.1 Materials for Cryo Applications for Fuel Containment
- 1.3 Bonded joining concepts
- 3.10 Point Load Introduction
- 3.18 Interaction between components
- 4.6 Thermally compliant joints
- 4.7 Failure Mechanisms at Cryogenic Temperature
- 5.1 Define Damage Tolerance Requirements
- 5.9 Better understand & refine minimum gage specifications
- 7.1 MMOD protection (lunar/IEO)

Note: Items 1.3 and 3.18 scored 180. Remaining items scored 270.



# Proposed Solutions to Technology Barrier Issues for LSAM Ascent Stage LCH<sub>4</sub> Tanks

ID Code No.	Proposed Solution
1.1	Optimize/formulate resins for space/cryogenic applications
1.3	Concepts for large temperature gradients
3.18	Joints for attachment of thin wall tanks
4.6	Same as 1.3
4.7	Micromechanics modeling of constituents
5.1	Define scenarios and damage detection levels
5.9	Same as 5.1
7.1	Analyze threats to tank concepts, test & validate

