

*Keisa R. Rosales<sup>1</sup> and Joel M. Stoltzfus<sup>2</sup>*

## Advanced Crew Escape Suits (ACES)

### Particle Impact Test

---

**ABSTRACT:** NASA Johnson Space Center (JSC) requested NASA JSC White Sands Test Facility to assist in determining the effects of impaired anodization on aluminum parts in advanced crew escape suits (ACES). Initial investigation indicated poor anodization could lead to an increased risk of particle impact ignition, and a lack of data was prevalent for particle impact of bare (unanodized) aluminum; therefore, particle impact tests were performed. A total of 179 subsonic and 60 supersonic tests were performed with no ignition of the aluminum targets. Based on the resulting test data, WSTF found no increased particle impact hazard was present in the ACES equipment.

**Keywords:** aluminum anodization; particle impact ignition testing; advanced crew escape suit (ACES)

---

<sup>1</sup> Chemical Engineer, NASA Test and Evaluation Contract, P.O. Box 20, Las Cruces, New Mexico 88004.

<sup>2</sup> Project Manager, NASA White Sands Test Facility, P.O. Box 20, Las Cruces, New Mexico 88004.

## **Introduction**

NASA Johnson Space Center (JSC) requested NASA JSC White Sands Test Facility (WSTF) to assist in determining the effects of impaired anodization on aluminum parts in the advanced crew escape suits (ACES). The ACES equipment has been used on the Orbiter at nominal pressures of 100 psig with a maximum pressure of 245 psig. Initial investigation raised concerns that poor anodization could lead to an increased risk of particle impact ignition, and a lack of data was prevalent for particle impact of bare (unanodized) aluminum; therefore, particle impact tests were performed. A total of 179 subsonic and 60 supersonic tests were performed with no ignition of the aluminum targets. This paper summarizes the test methods and results.

## **Objective**

Testing was performed to evaluate whether aluminum test samples would be subject to ignition and sustained burning in a given flow environment when impacted by particulate. The effect of the impact at specified temperatures, pressures, and flow rates was also evaluated.

## **Test Methods**

Test variables were determined by the worst-case conditions that occur in the components of concern. Because the components could be exposed to any degree of particle impact velocity, subsonic and supersonic particle impact tests were performed using a variety of particulate mixtures.

### *Materials*

A variety of particulate mixtures (powder and particles) was used for testing. Powders consisted of 1) commercially pure -100 + 325 mesh titanium grade II powder manufactured by Advanced Specialty Metals, Incorporated (Nashua, New Hampshire); 2) stainless steel powder with a maximum size of 150  $\mu\text{m}$ ; and 3) aluminum powder containing a large spectrum of particle dimensions. The smallest particles were 1 to 2  $\mu\text{m}$  in diameter, and the largest spherical particles were 1 mm in diameter. Slivers

were 4 to 5 mm in length. One 1587- $\mu\text{m}$  diameter spherical aluminum particle and one 500- $\mu\text{m}$  diameter spherical stainless steel particle were also injected in the subsonic tests. For the tests with the subsonic injector and supersonic nozzle configuration, the aluminum powder was sifted to have a maximum size of 200  $\mu\text{m}$ .

The target sample material was unanodized aluminum. This material corresponded to the impingement points in the ACES where a possible particle impact hazard existed within the oxygen manifold (Figure 1), quick-disconnect (Figure 2), and g-suit controller (Figure 3) components. The subsonic target samples were used in two different configurations. The standard subsonic targets were 90-degree, 0.060-in. (1524  $\mu\text{m}$ ) thick flat discs with holes drilled near the outside diameter to allow flow through the target (Figure 4). In addition, subsonic targets were configured to simulate 118-degree drill points in passages of ACES equipment (Figure 5). The standard supersonic targets were configured in a cup shape with an outside diameter that allowed flow around the 0.060-in.-thick target surface. The sample was press-fitted onto a copper sample holder (Figure 6). Before testing, the samples were prepared at WSTF, cleaned, and then sealed in polypropylene bags until testing. From this point, the targets were handled with latex gloves to maintain the cleanliness level.

### *Procedures*

For the subsonic particle impact tests, the particulate was loaded into the injector, and the injector cap was then threaded onto the housing. The target sample and orifice were then positioned on the end of the subsonic chamber (Figure 7). The test conditions were 245 + 50/-0 psig, 90 + 110/-0 °F, and 200 ft/s.

For the supersonic particle impact tests, which used the subsonic injector with the supersonic nozzle, the particulate was loaded into the injector, and the injector cap was threaded onto the housing. The target sample and copper posts were then positioned at the end of the supersonic nozzle (Figure 8). The test conditions were 245 + 50/-0 psig, 90 + 110/-0 °F, and Mach 1.

After system preparation was complete, the test area was cleared of personnel and placed in RED (no access allowed) status. A video camera was positioned to record any reaction visible at the end of the

test fixture. Heated gaseous aviator's breathing oxygen (ABO)-grade oxygen at test pressure was allowed to flow until the desired temperature of the target sample was achieved and the gas flow stabilized. Upon command, the particulate was injected into the chamber. After evidence of impact, which was indicated by a flash, the oxygen flow was terminated. The test system was allowed to vent down to ambient pressure ~ 4 s after particle injection. To verify that particle impact occurred, the target sample was visually inspected after each test. Each sample was then individually bagged, labeled with test information, and kept with its original bag containing the remaining sample material. The test computer saved the test data and system data. The test pressure, test temperature, and average flow meter reading were recorded in the laboratory test log book. Video tapes of the reaction were recorded and stored. At the completion of test data storage and sample inspection, the procedure was repeated.

## Results and Discussion

For unanodized aluminum target samples with 5 mg of aluminum and stainless mixture or worse, 239 tests were performed in 100 percent oxygen. The effects of impact on the test samples at the given temperatures, pressures, and flow rates were determined visually and characterized by three categories:

- *No burn*: no particle indentations or erosion is apparent on the target surface.
- *Particle burn*: one or more particle indentations are apparent on the target surface, including damage from erosion.
- *Target burn*: a portion or the entire sample is consumed; the target is often not recoverable.

During particle impact ignition testing, the parameters of concern were temperature, pressure, particle composition, target, and configuration. The variables of particle size, particle material, mass flow rate, temperature, and pressure were determined by the worst-case conditions that occur in the components.

Three series of subsonic particle impact tests were performed on 6061-T6 aluminum targets, and another three series of tests were performed on 6061-T6 aluminum targets using the subsonic injector

with the supersonic nozzle to inject particulate and reach near-supersonic velocities. A total of six test series were performed. The particulate mixtures are described in Table 1, and the test results are summarized in Table 2.

#### *Test Series 1 - Checkout Tests*

The target configuration used was the flat standard sample configuration. The particulate mixture was ~10 mg of titanium particulate (with a maximum size of 150  $\mu\text{m}$ ), plus one 1587- $\mu\text{m}$ -diameter spherical aluminum particle and one 500- $\mu\text{m}$ -diameter spherical stainless steel particle. The gas stream velocities ranged from 357 to 475 ft/s. A total of 59 tests were performed with no ignition of the aluminum targets (Figures 9, 10, and 11).

#### *Test Series 2*

The target configuration used was the flat standard sample configuration. The particulate mixture was ~ 10 mg of a mixture of aluminum (mostly 100 to 200  $\mu\text{m}$ ) and stainless steel particulate (with a maximum size of 150  $\mu\text{m}$ ), plus one 1587- $\mu\text{m}$ -diameter spherical aluminum particle and one 500- $\mu\text{m}$ -diameter spherical stainless steel particle. The gas stream velocities ranged from 375 to 464 ft/s. A total of 60 tests were performed with no ignition of the aluminum targets (Figures 12 and 13).

#### *Test Series 3 – Checkout Tests*

The target configuration simulated the 118-degree drill points in passages of ACES equipment. The particulate mixture was ~ 10 mg of a mixture of titanium powder (with a maximum size of 150  $\mu\text{m}$ ), plus one 1587- $\mu\text{m}$ -diameter spherical aluminum particle and one 500- $\mu\text{m}$ -diameter spherical stainless steel particle. The gas stream velocities ranged from 375 to 397 ft/s. A total of 60 tests were performed with no ignition of the aluminum targets (Figures 14, 15, and 16).

#### *Test Series 4 – Checkout Tests*

The target configuration used was the standard supersonic configuration. The particulate mixture was ~ 10 mg of a mixture of aluminum (mostly 100 to 200  $\mu\text{m}$ ) and stainless steel particulate (with a maximum size of 150  $\mu\text{m}$ ). A total of five tests were performed with no ignition of the aluminum targets (Figure 17).

*Test Series 5 – Checkout Tests*

The target configuration used was the standard supersonic configuration. The particulate mixture was ~ 10 mg of a mixture of aluminum (with a maximum size of 200  $\mu\text{m}$ ) and stainless steel particulate (with a maximum size of 150  $\mu\text{m}$ ). Four of the 11 tests used a 6000-series aluminum target instead of the 6061-T6 aluminum targets. A total of 11 tests were performed with no ignition of the aluminum targets (Figure 18).

*Test Series 6*

The target configuration used was the standard supersonic configuration. The particulate mixture was a 5-mg mixture consisting of 1.25 mg of aluminum (with a maximum size of 200  $\mu\text{m}$ ) and 3.75 mg of stainless steel (with a maximum size of 150  $\mu\text{m}$ ). A total of 60 tests were performed with no ignition of the aluminum targets (Figures 19 and 20).

**Conclusions**

Six series of tests were performed on unanodized aluminum 6061-T6 targets at subsonic and supersonic velocities to determine if a particle impact ignition hazard existed in the ACES components. In the 255 tests with a variety of particle mixes, no ignition and sustained burning of the aluminum occurred. Although particle burns were on the samples, it is surmised that the residence time of the particles in all tests was not long enough for the fire to propagate to the aluminum. It was determined that no particle impact ignition hazard would be present if contaminant were to reach the ACES components.

TABLE 1—*Particulate mixtures used for testing.*

Particulate Mixture	Material	Size and Configuration	Amount
A	Titanium	$\leq 150 \mu\text{m}$	$\sim 10 \text{ mg}$
	Aluminum	1587- $\mu\text{m}$ -diameter spherical particle	QTY-1
	Stainless steel	500- $\mu\text{m}$ -diameter spherical particle	QTY-1
B	Mixture of aluminum and stainless steel particulate	Aluminum, mostly 100 to 200 $\mu\text{m}$ Stainless steel, $\leq 150 \mu\text{m}$	$\sim 10 \text{ mg}$
	Aluminum	1587- $\mu\text{m}$ -diameter spherical particle	QTY-1
	Stainless steel	500- $\mu\text{m}$ -diameter spherical particle	QTY-1
C	Mixture of aluminum and stainless steel particulate	Aluminum, mostly 100 to 200 $\mu\text{m}$ Stainless steel, $\leq 150 \mu\text{m}$	$\sim 10 \text{ mg}$
D	Mixture of aluminum and stainless steel particulate	Aluminum – $\leq 200 \mu\text{m}$ Stainless steel, $\leq 150 \mu\text{m}$	$\sim 10 \text{ mg}$
E	Mixture of aluminum and stainless steel particulate	1.25 mg of aluminum, $\leq 200 \mu\text{m}$ 3.75 mg of stainless steel, $\leq 150 \mu\text{m}$	5 mg

TABLE 2—Particle impact tests results summary.

Test Series	Test System Configuration	Target Configuration	Particulate Mixture <sup>a</sup>	Test Pressure (psig)	Test Temperature (°F)	Gas Stream Velocity (ft/s)	Number of Tests	Number of Target Ignitions
1 Checkout	Subsonic injector with subsonic nozzle	Flat standard subsonic sample	A	245	90	357-475	59	0
2	Subsonic injector with subsonic nozzle	Flat standard subsonic sample	B	245	90	375-464	60	0
3	Subsonic injector with subsonic nozzle	118-degree drill point subsonic sample	A	245	90	375-397	60	0
4 Checkout	Subsonic injector with supersonic nozzle	Standard supersonic sample	C	245	90	Mach 1	5	0
5 Checkout	Subsonic injector with supersonic nozzle	Standard supersonic sample	D	245	90	Mach 1	11	0
6	Subsonic injector with supersonic nozzle	Standard supersonic sample	E	245	90	Mach 1	60	0

<sup>a</sup> Particulate mixtures are described in Table 1.



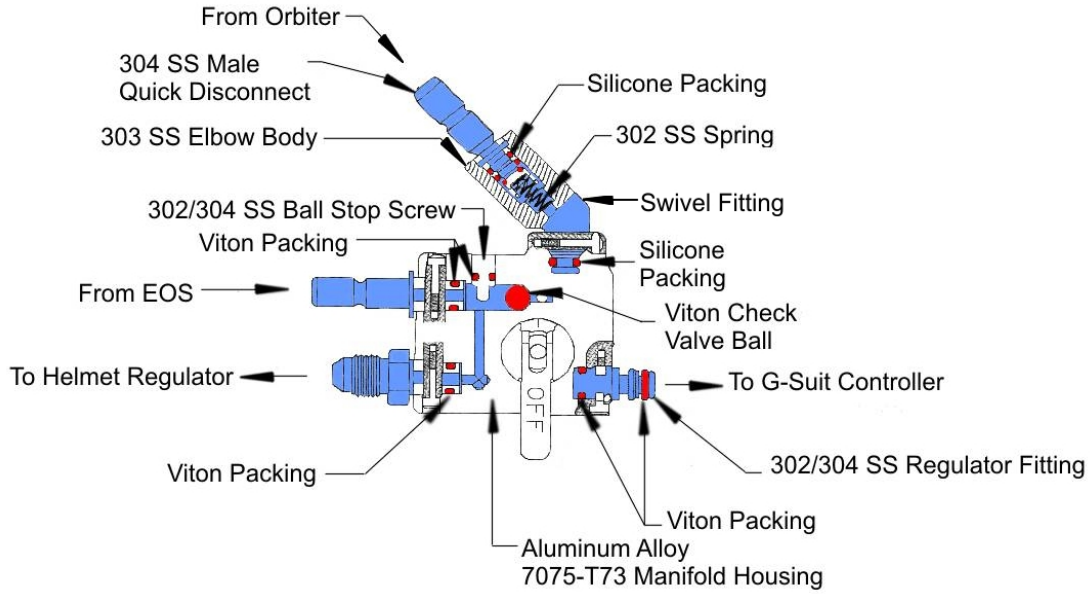

FIG. 1—Oxygen manifold.

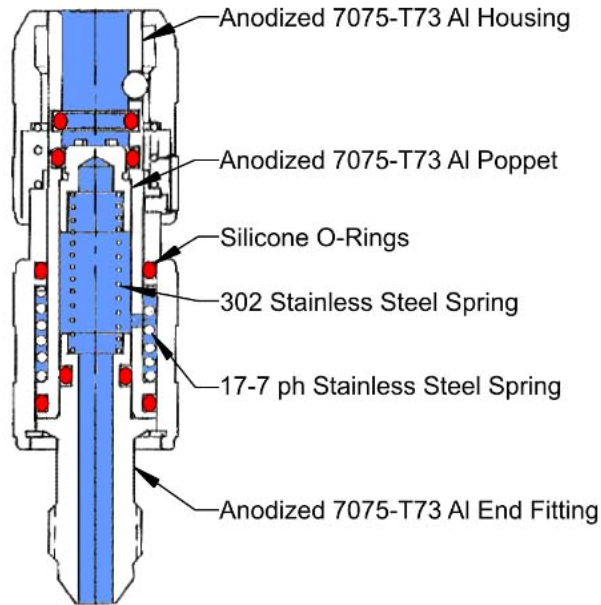

FIG. 2—Quick-disconnect.

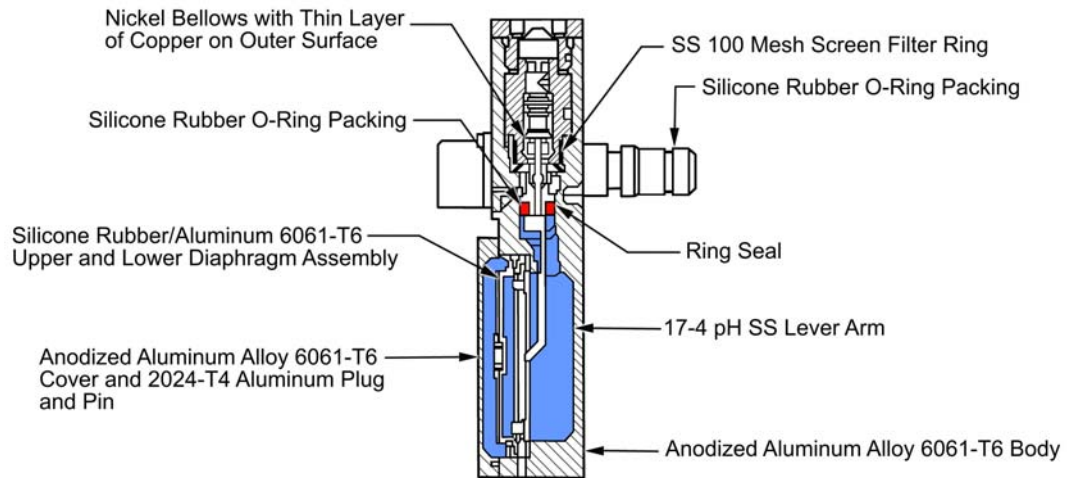

FIG. 3—*G-suit controller.*

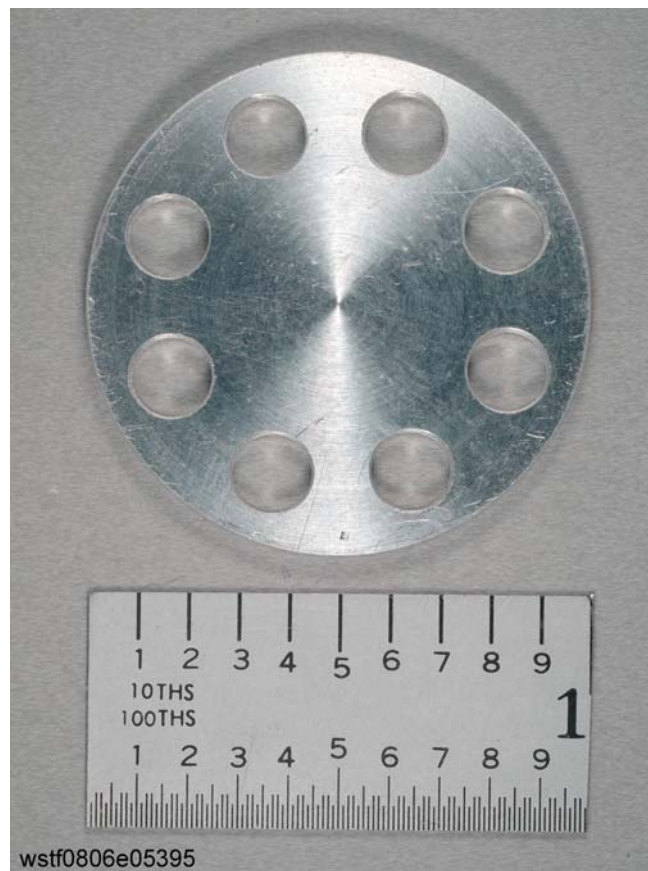

FIG. 4—*Standard subsonic flat target configuration.*

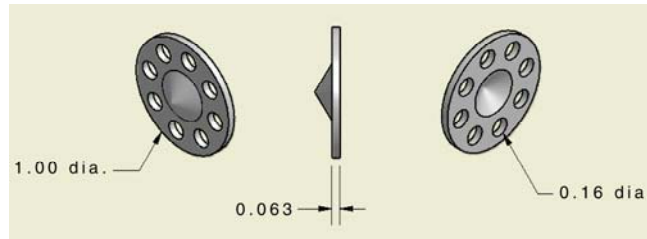

FIG. 5—Subsonic 118-degree drill point target configuration.



FIG. 6—Standard supersonic target configuration.

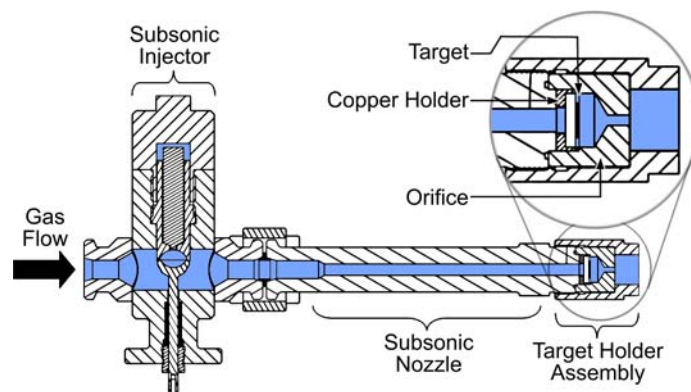

FIG. 7—WSTF subsonic particle impact test system.

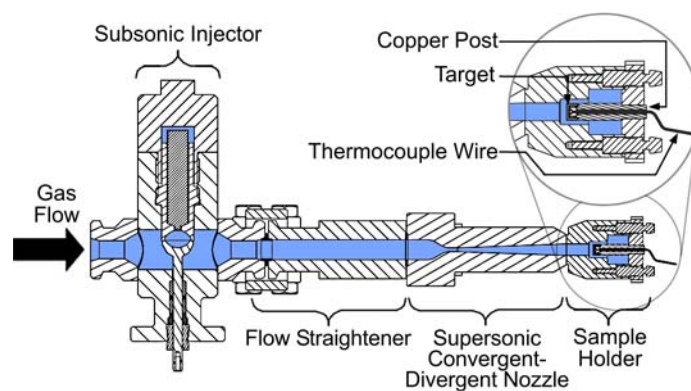

FIG. 8—Subsonic injector with supersonic nozzle.

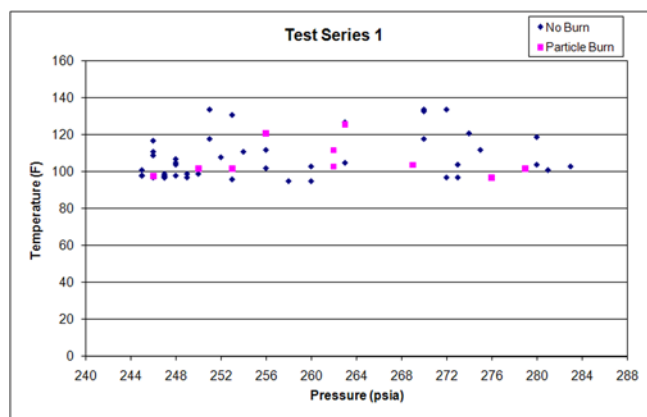

FIG. 9—Test Series 1.

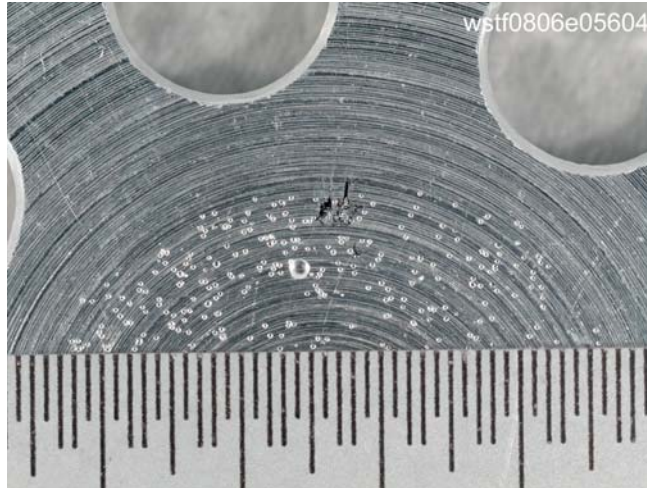

FIG. 10—Typical subsonic flat target test results of a particle burn with titanium (Test Series 1).



FIG. 11—Typical subsonic flat target test results of a no burn with titanium (Test Series 1).

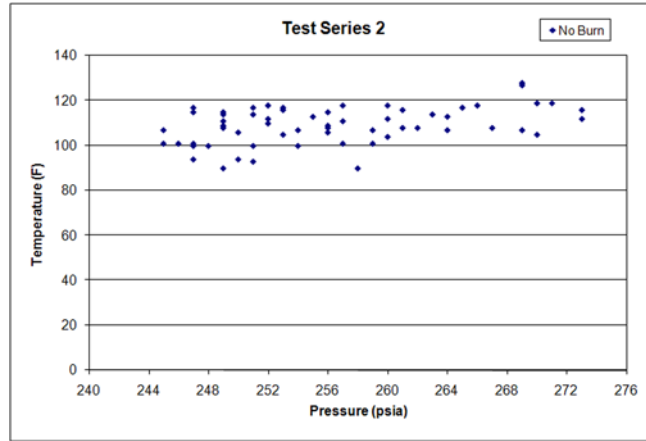

FIG. 12—Test Series 2.

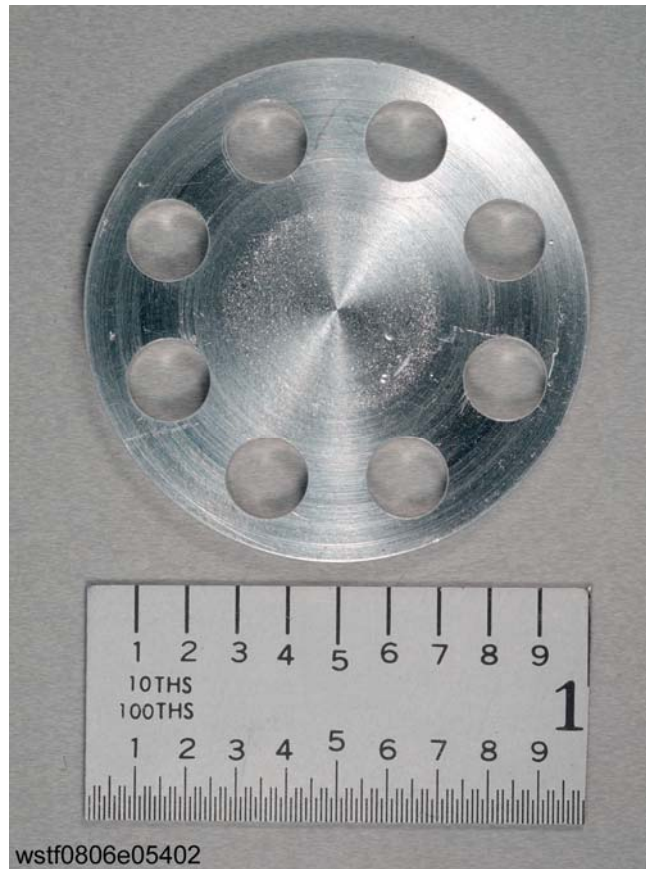

FIG. 13—Typical subsonic flat target test results of a no burn with aluminum (Test Series 2).

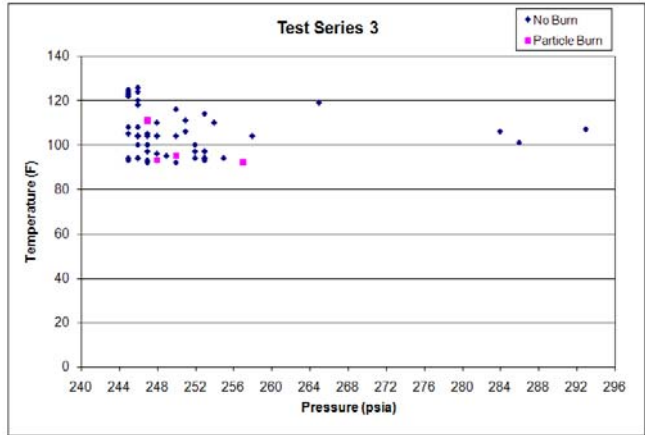

FIG. 14—*Test Series 3.*

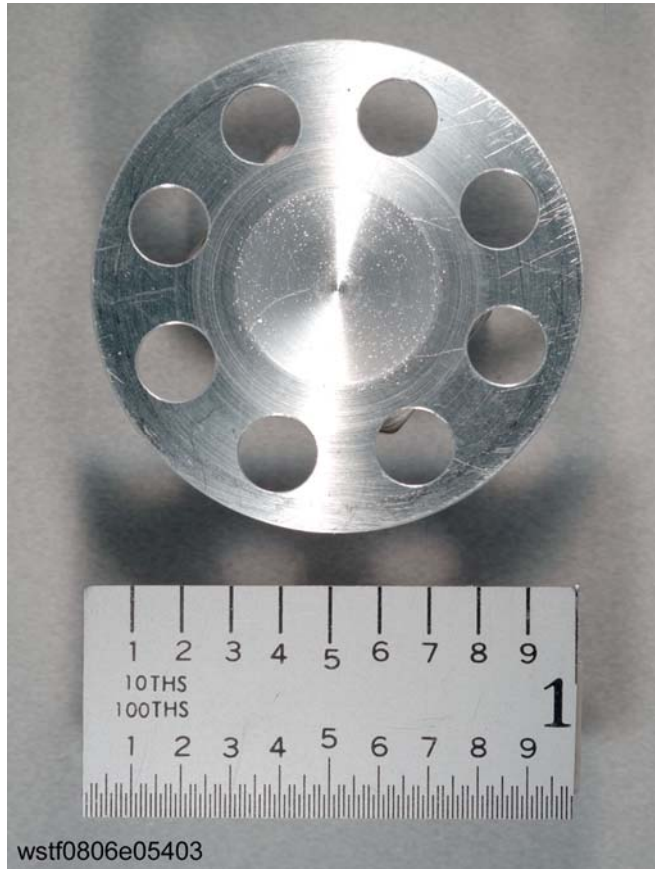

FIG. 15—*Typical subsonic drill point target test results of a no burn with titanium (Test Series 3).*

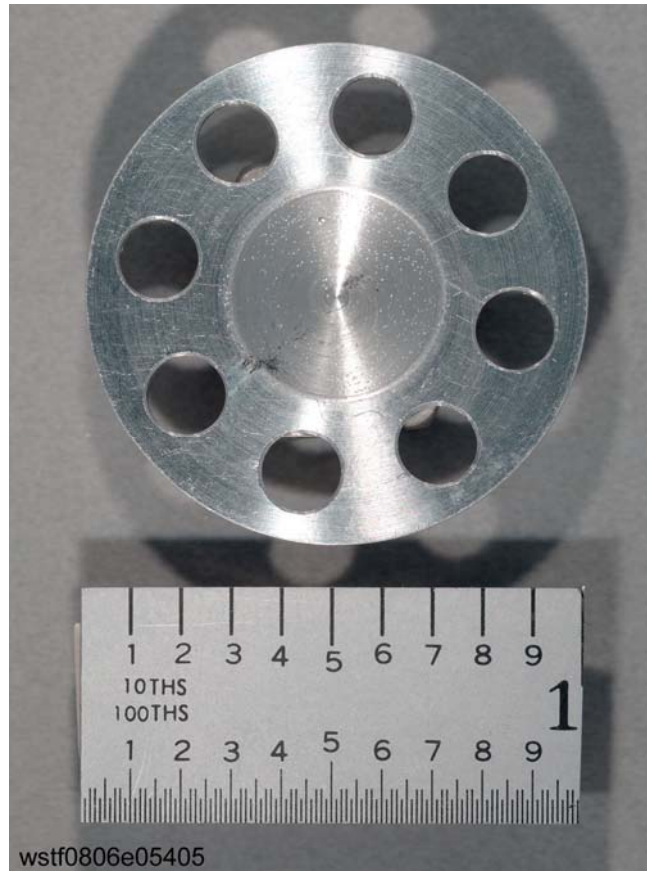

FIG. 16—Typical subsonic drill point target test results of a particle burn with titanium (Test Series 3).



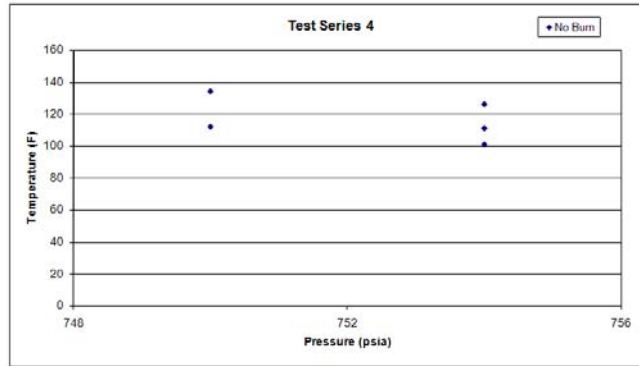

FIG. 17—Test Series 4.

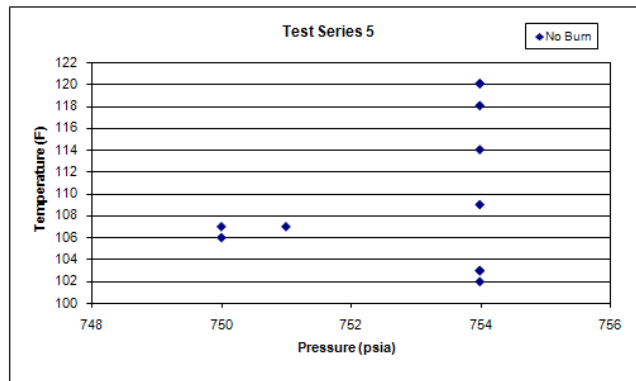

FIG. 18—Test Series 5.

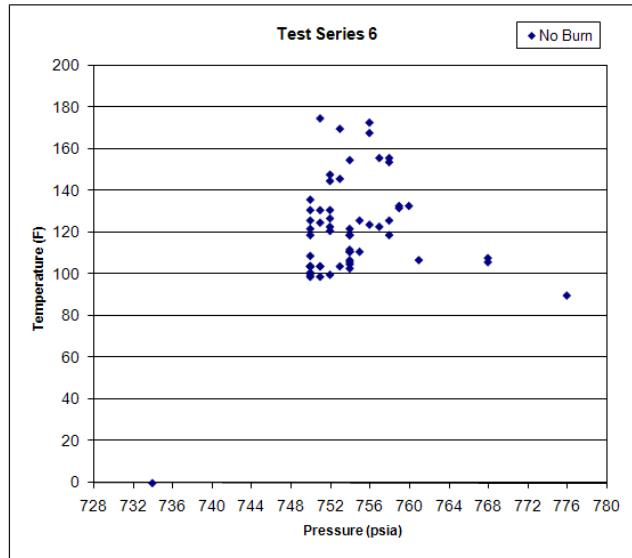

FIG. 19—Test Series 6.



FIG. 20—Typical supersonic target test results of a no burn with aluminum (Test Series 6).