

IAC-C3.2.5
SOLAR CONCENTRATOR DEMONSTRATOR FOR LUNAR REGOLITH
PROCESSING

Author

John C. Fikes, Project Manager
National Aeronautics & Space Administration, George C. Marshall Space Flight Center
Marshall Space Flight Center, Alabama 35812, USA
John.Fikes@nasa.gov

Co-authors

Joe T. Howell, Aerospace Engineer
National Aeronautics & Space Administration, George C. Marshall Space Flight Center
Marshall Space Flight Center, Alabama 35812, USA
Joe.Howell@nasa.gov

Harold P. Gerrish
National Aeronautics & Space Administration, George C. Marshall Space Flight Center
Marshall Space Flight Center, Alabama 35812, USA
Harold.P.Gerrish@nasa.gov

Stephen L. Patrick, Senior Engineer
Jacobs Technology Inc.
Marshall Space Flight Center, Alabama 35812, USA
Stephen.L.Patrick@nasa.gov

ABSTRACT

NASA at the Marshall Space Flight Center (MSFC) is building a portable inflatable solar concentrator ground demonstrator for use in testing in-situ resource utilization (ISRU) lunar regolith processing methods. Of primary interest is the production of oxygen as a propellant oxidizer and for life support. There are various processes being proposed for the in-situ reduction of the lunar regolith, the leading processes are hydrogen reduction, carbothermal reduction and vapor phase pyrolysis. The concentrator system being built at MSFC could support demonstrations of all of these processes. The system consists of a light inflatable concentrator that will capture sunlight and focus it onto a receiver inside a vacuum chamber. Inflatable concentrators are good for space based applications due to their low weight and dense packaging at launch. The hexapod design allows the spot size to be increased to reduce the power density if needed for the process being demonstrated. In addition to the hardware development, a comprehensive simulation model is being developed and will be verified and validated using the system hardware. The model will allow for the evaluation of different lunar locations and operational scenarios for the lunar regolith processing with a high confidence in the predicted results.

INTRODUCTION AND BACKGROUND

As the new Exploration Initiative proceeds the need for the utilization of in-situ resources and materials to support long term missions and finally autonomous colonies to the Moon becomes more important. Of primary concern is the production of oxygen for both propellant oxidizer and for life support. Over 20 processes for the extraction of oxygen from the lunar regolith have been studied. Hydrogen Reduction, Carbothermal Reduction and Vacuum Pyrolysis are the three processes that show the most near term promise. All of these processes can use direct solar energy input to drive the process. All of the processes require considerable refinement before a system suitable for deployment to the Moon is designed. NASA at Marshall Space Flight Center (MSFC) is building a portable inflatable solar concentrator system based on an inflatable solar concentrator designed for a space propulsion system. The system was designed under the Air Force's Integrated High Payoff Rocket Propulsion Technology (IHRPT) Program managed by the Air Force Research Laboratory (ARFL). A concept of the Solar Thermal Propulsion System is shown in Figure 1. MSFC was a participant in the program before its cancelation in mid 2004. Major elements of the demonstration system being developed under this program were transferred to MSFC. Because of the inflatable characteristic of the concentrator it is portable and can be transported to remote sites for simulated in-situ testing. The basic configuration of the concentrator and its stand are shown in Figure 2. By using the hardware from the Solar Thermal Propulsion IHRPT Demonstration Program a

considerable cost savings was achieved over fabricating the system from the ground up.

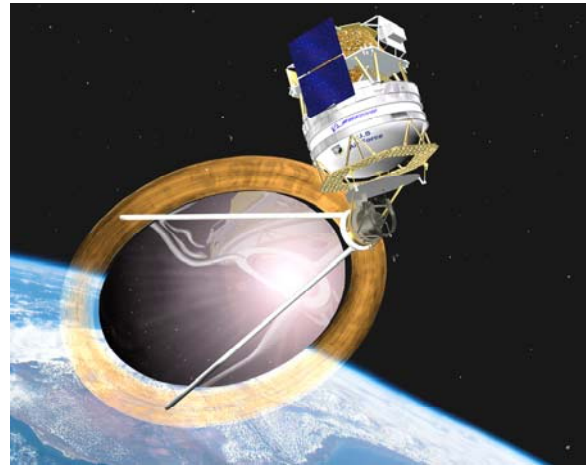

Figure 1. Solar Concentrator Orbit Transfer Vehicle Concept

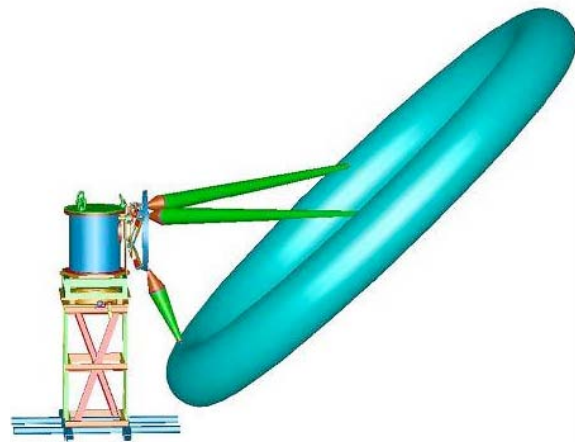

Figure 2. IHRPT Solar Concentrator System Ground Demonstrator

The Portable Inflatable Solar Concentrator System can provide sufficient energy to achieve the temperatures required to drive all three processes, therefore, providing a source of energy for the further development of the processes. In addition, the system's flexibility allows it to be adapted to other processes in the future.

SOLAR CONCENTRATOR STRUCTURE

The Portable Inflatable Solar Concentrator System uses the base and vacuum chamber from the IHRPT Solar Concentrator System Ground Demonstrator, shown in Figure 3, without any major modification.



Figure 3. IHRPT Solar Concentrator System Ground Demonstrator base and vacuum chamber.

The base and vacuum chamber weighs approximately 900 kg providing a significant mass to support the large inflatable concentrator assembly. To provide additional stability the base has outriggers extending from each side that are fitted with jack screws for leveling. The vacuum chamber's base is mounted on a large bearing assembly that allows the chamber to be rotated 360°. The bearing is driven by a belt connected to a motor that is

driven by the control system. This provides control of the azimuth of the solar concentrator assembly. The top and bottom plates along with the port are fitted with o-rings to allow the vacuum chamber to be operated under vacuum conditions. The vacuum chamber has multiple feed-thrus for gasses and instrumentation. The vacuum chamber has a 25 cm port to allow the solar flux to enter the chamber. A plate with a hole to permit the solar flux to enter the port on the vacuum chamber is mounted on the vacuum chamber in front of the port. A bearing assembly mounted on the plate interfaces with a gimbal platform as shown in Figure 4.



Figure 4. Vacuum Chamber with mounting plate and gimbal platform.

A belt connected to another motor drives the bearing assembly through 360° of rotation. This provides control of the elevation of the solar concentrator assembly. The base has panels for pressure gauges, flow meters and control valves. The systems control

computer and instrumentation system are located within the base.

INFLATABLE SOLAR CONCENTRATOR

The Inflatable Solar Concentrator uses the same design as the AFRL 4m x 6m Solar Concentrator, shown in Figure 5. The concentrator design is an off-axis parabola design that provides a clear aperture diameter of 4.17 meters.



Figure 5. ARFL 4m x 6m Solar Concentrator

The ARFL inflatable concentrator was formed by casting NASA Langley Research Center's CP-1 polymer over a mandrel (shown in Figure 6.) machined to the off-axis parabolic shape.

Two new inflatable concentrator assemblies have been fabricated using the AFRL mandrel using and a newer polymer, CP-2.



Figure 6. ARFL 4m x 6m Mandrel

The MSFC Inflatable Solar Concentrator Assembly, shown in Figure 7, is mounted in a rigidized torus the same dimensions as the ARFL inflatable torus.



Figure 7. MSFC Inflatable Solar Concentrator

The assembled Inflatable Solar Concentrator's overall dimensions are 5.3 m x 7.3 m but it only weighs 20 kg. This light weight allows the system to use relative small actuators to control the motion of the concentrator. In addition the inflatable design allows for an extremely small packing volume for launch. Under the AFRL Program extensive deployment testing was successfully conducted on the inflatable concentrator in a vacuum environment. This provides confidence that

a system using the inflatable concentrator technology could be effectively deployed to the moon for use as part of an oxygen generation system. Because of the off-axis optical design the aperture area of the concentrator is 13.65 m² without any obstructions. A conservative analysis of the optical system predicts that it will deliver 5.5 KW of power in a focus area of 6 cm in diameter. This represents a concentration ratio of 2400X for the system and requires the control system to track the sun to within 0.1°.

The operating temperature ranges for the three oxygen generation processes previously discussed are:

Hydrogen Reduction	800° - 1100° C
Carbothermal Reduction	1600° - 1800° C
Vacuum Pyrolysis	1800° - 2200° C

An analysis shows that with an energy input of 5500 J/sec these operating temperatures can be achieved.

GIMBAL PLATFORM

The Inflatable Concentrator Assembly is mounted to a gimbal platform, shown in figure 8, with three fiberglass struts, the gimbal platform is then mounted to six bearings on the mounting plate which is attached to the vacuum chamber. This configuration provides the elevation mechanism and allows the gimbal platform with the Inflatable Concentrator Assembly to rotate 360° around the elevation axis. The configuration of the gimbal platform is called a Hexapod or Stewart Platform shown in Figure 8. This configuration has two planes defined as a base plane and a platform plane. These planes are connected by six actuators and providing six degrees of

freedom (DOF) of movement between the planes.

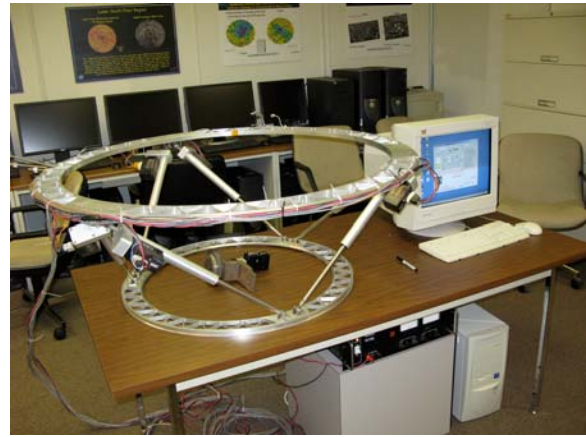

Figure 8 Hexapod (Stewart Platform)

The gimbal platform has two rings that define the base and platform planes. By changing the length of the actuators a point on the platform ring can be translated in the x,y,z coordinate axes and/or rotated about each axes. The hexapod allows the focal point of the concentrator assembly to be moved laterally ± 7 cm along the x and y axes to move the focal point on the target material. The focal point can also be moved 25 cm along the z axis to effectively defocus the beam thereby reducing the energy density in the test plane.

CONTROL SYSTEM AND DATA ACQUISITION

The control system for the Inflatable Solar Concentrator System uses a brushless DC Servo Motor called a SmartMotor. The SmartMotor has an internal computer, a RS-232 serial interface and an internal encoder that indicates the position of the motor's shaft. The SmartMotors used in the Solar Concentrator's control system have 2,000 increments per revolution of the motor's shaft (0.18° resolution). The

azimuth and elevation motors are fitted with a 100:1 ratio gearbox that results in 200,000 steps per revolution (6.5 second resolution). SmartMotors drive the six linear actuators on the hexapod gimbal platform. Each actuator has a maximum stroke of 20 cm. Each step of the SmartMotor moves the actuator 0.0026 mm. Because of the precision tracking required by the high concentration ratio of the concentrator assembly some method of determining the actual position of the solar concentrator is required. To accomplish this each of the linear actuators are fitted with a linear potentiometer connected to a National Instruments SCXI Data Acquisition System. A 4-quadrant photo detector system mounted on an optical system that images the sun on the detector provides a vertical and horizontal error signal based on the position of the sun. These signals also are fed into the SCXI Data Acquisition system. The Solar Position Control Flow is shown in Figure 9.

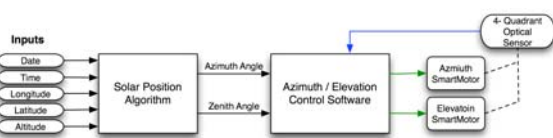

Figure 9 Solar Position Control Flow

The position of the sun is computed based on the physical location of the system and the time/date information. The control computer commands the actuators to the computed location. The 4-quadrant detector first determines if there is cloud cover, with cloud cover no correction is made and the system continues to track using only the computer program. If there is no cloud cover the vertical and horizontal error signals are used to correct the actual position of the concentrator with respect to the sun.

The internal registers of the SmartMotors are updated, this will zero out the previous error in the system. The control system then performs another computation of the solar position and repeats the process.

The hexapod is used to precisely locate the focal point of the concentrator system in the vacuum chamber. A six DOF inverse kinematic algorithm has been developed to compute the length of the six linear actuators based on the desired location and vacuum rotation of the focal point. The Hexapod Control Flow is shown in Figure 10.

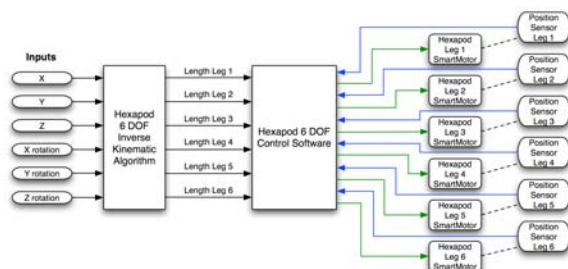

Figure 10 Hexapod Control Flow

The x,y,z location and the rotation around each of the axes is provided to the inverse kinematic routine, the lengths of the actuators are computed and the computer commands the SmartMotors to the desired locations. The system then reads the potentiometers on each of the actuators to determine if there is any error, if an error exists between the actual and commanded positions, corrections are provided and as with the Solar Position Control the internal registers of the SmartMotors are updated to zero out the previous error.

GRAPHICAL USER INTERFACE

While considerable hardware was available from the AFRL Program none of the software was available. The primary problem was that the original control

software was developed using expensive software development systems. When the program was closed, this software was removed for use elsewhere and is no longer available for use with the solar concentrator. Since there was no previous software the software engineers decided to develop the required software using open source and /or publicly available software. Python was selected as the primary language to be used for development.

Engineers developing the control software for the Solar Concentrator motors chose a free, open source software system named Blender. Development functions provided by Blender include 3D modeling, animation, and a game engine with a Python Application Programming Interface (API). With the game engine, a developer can incorporate a two-joystick video game controller and compile a stand-alone executable file. A Python Serial code library enabled communication with Smart motors that actuate gears for azimuth and elevation rotations and linear actuators for the hexapod stewart platform. The development team translated a Solar Position Algorithm (SPA), originally coded in C, by the National Renewable Energy Laboratory into Python and added code to control the azimuth and elevation motors. A data acquisition system, by National Instruments, includes a library of C++ routines to read measurement devices for the actuators and gears. A Python routine will integrate the C++ code to enable development of a feedback and control system. Other Python routines read buttons and joystick positions from the video game controller and translate the input into angles for the hexapod actuators and the azimuth and elevation motors; these routines provide course and fine control of the Solar Concentrator angle

and position. Figure 11 presents a screenshot of Blender's Python API. The upper right corner frame displays Python code; the two larger frames present the model for the Graphical User Interface (GUI) from two different angles.

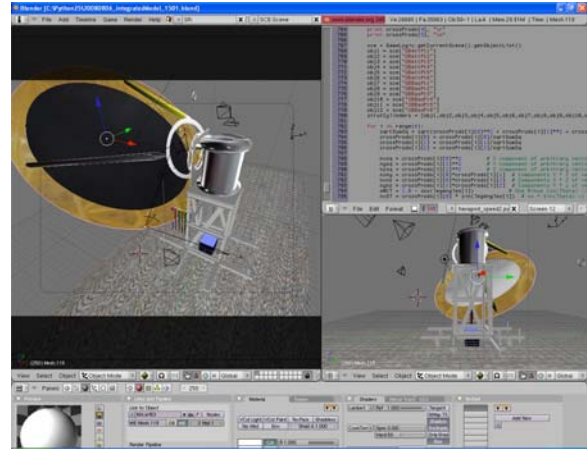

Figure 11 Blender Screen Shot of Python API.

Figure 12 presents a view of the GUI during the run mode

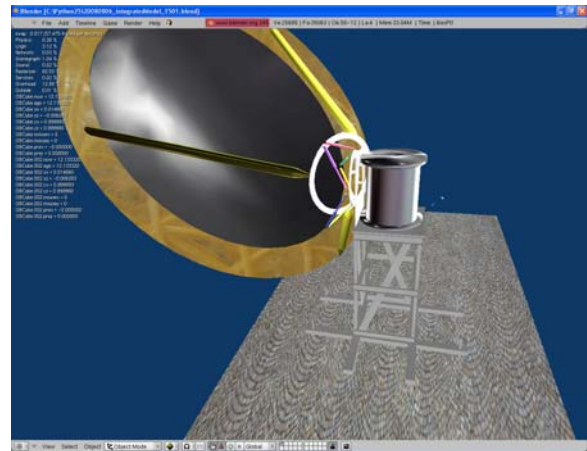

Figure 12 Screenshot of the Solar Concentrator GUI

With a video game controller, an engineer can manipulate the angle and position of the Solar Concentrator.

CONCLUSION

The current status of the Portable Inflatable Solar Concentrator System is that all the major elements are ready for assembly and integration. The current schedule is to complete the integration activity by late November and begin check-out and performance testing in December. If there are no problems interfacing, processing experiments could start in the first quarter of calendar year 2009.

REFERENCES

Hydrogen Reduction of Ilmenite from Lunar Regolith - a Progress Report; N. Remachandran, H. Willenberg, M. Volz; AIAA 2006-7482, AIAA Space 2006, San Jose, California, USA, September 2006.

Vacuum Pyrolysis and Related ISRU Techniques; E.H. Cardiff, B.R. Pomeroy, I.S. Banks, A. Benz; Space Technology and Application International Forum 2007, Albuquerque, New Mexico, USA, February 2007.

Solar Thermal Propulsion IHPRT Demo - Final Report; AFRL-PR-ED-TR-2006-0048; D.T. Lester, M.R. Holmes; Air Force Research Laboratory. Air Force Material Command, Edwards Air Force Base, California, USA.

Solar Propulsion Component Development - Final Report; AFRL-PR-ED-TR-2006-0049; M.R. Holmes; Air Force Research Laboratory. Air Force Material Command, Edwards Air Force Base, California, USA.



Solar Concentrator Demonstrator for Lunar Regolith Processing IAC-C3.2.5

**Presentation to 59th IAC Congress
Glasgow, Scotland
October 1, 2008**

Presenter:

Jerry B. Sanders

Johnson Space Center/USA

gerald.b.sanders@nasa.gov

Author:

John C. Fikes

Marshall Space Flight Center/USA

john.fikes@nasa.gov

Presentation Outline



- **Acknowledgements**
- **Introduction**
- **Background**
- **Solar Concentrator Structure**
- **NASA Inflatable Solar Concentrator**
- **Gimbal Platform**
- **Control System**
- **Data Acquisition**
- **Graphical User Interface**
- **Conclusion**

Acknowledgements



Co-Authors: John Fikes/MSFC, Joe Howell/MSFC, Harold Gerrish/MSFC, Carole McLemore/MSFC, Steve Patrick/Jacobs Technology Inc.

- MSFC Solar Concentrator Team
- Jacobs Technology Inc.
- Man Tech SRS Technologies
- Science Applications International Corporation (SAIC)

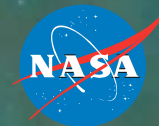

Introduction

Take advantage of in situ resources rather than depending on deliveries and supplies from Earth

- Utilization of in-situ resources is important for long term missions to the moon.
- Production of oxygen for propellant oxidizer and life support are key elements
- Hydrogen Reduction, Carbothermal Reduction, Vacuum Pyrolysis and Molten Oxide Electrolysis are all candidate processes that can be driven by the Solar Concentrator.
- NASA at Marshall Space Flight Center (MSFC) is building a **portable inflatable** solar concentrator system to be used for detailed process evaluation and demonstration.

Background

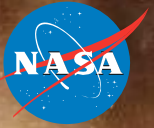

- The NASA Portable Inflatable Solar Concentrator System used technologies developed under the NASA/AFRL's Integrated High Payoff Rocket Propulsion Technology (IHPRPT) Program managed by the Air Force Research Laboratory (AFRL).
- Ground demonstration hardware from this program is being used to develop the NASA system.
- The NASA System can provide sufficient energy to achieve the temperatures required to drive all four processes.
- The system's flexibility allows it to be adapted to other processes in the future.

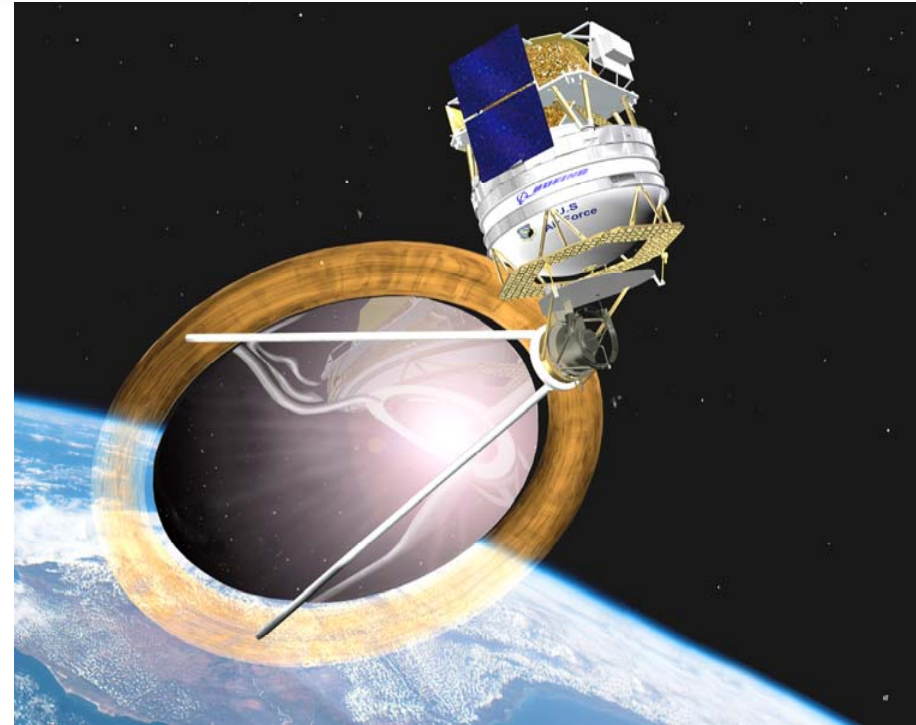

Solar Concentrator Orbit Transfer Vehicle Concept

Background (Continued)

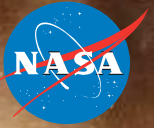

- Major Elements Transferred from the NASA/AFRL Program Include:
 - 4m X 6m Mandrel
 - Ground Demonstrator Base and Vacuum Chamber
 - Rigidized Torus
 - Hexapod (Stewart Platform)

- Utilization of Hardware from Solar Thermal Propulsion IHRPT Demonstration Program resulted in considerable cost savings



ARFL 4m x 6m Solar Concentrator

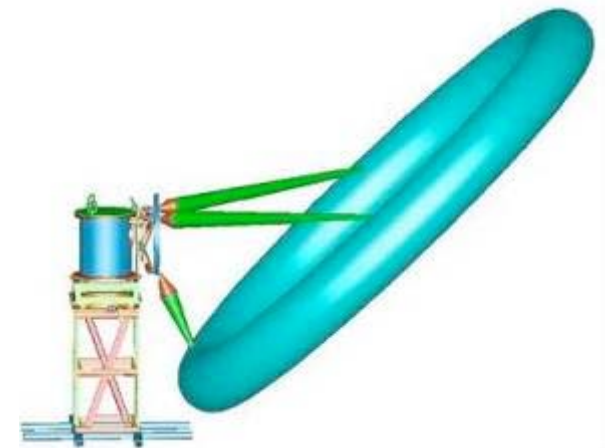

IHRPT Solar Concentrator System
Ground Demonstrator

NASA Inflatable Solar Concentrator

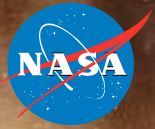

- The NASA Inflatable Solar Concentrator uses the same design as the NASA/AFRL 4m x 6m Solar Concentrator, an off-axis parabola design that provides an aperture diameter of 4.17 meters.
- The Concentrator's overall dimensions are 5.3 m x 7.3 m but it only weighs 20 kg.
- A conservative analysis of the optical system predicts that it will deliver 5.5 KW of power in a focus area of 6 cm in diameter.



NASA Inflatable Solar Concentrator Ground Demonstrator

Gimbal Platform

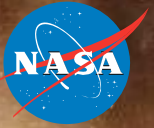

- The Inflatable Concentrator Assembly is mounted to a gimbal platform with three fiberglass struts.
- The configuration of the gimbal platform is called a Hexapod or Stewart Platform and has two planes connected by six actuators and provides six degrees of freedom (DOF) of movement between the planes.
- The hexapod translates the focal point laterally ± 7 cm along the x and y axes to allow focal point movement on the target material. The focal point can be moved 25 cm along the z axis to effectively defocus the beam thereby reducing the energy density in the test plane.



Hexapod Gimbal Platform

Inflatable Solar Concentrator Structure

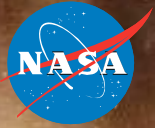

- The NASA Solar Concentrator System uses the base and vacuum chamber from the IHRPT Ground Demonstrator.
- The base and vacuum chamber weighs approximately 900 kg providing a significant mass to support the large inflatable concentrator assembly.
- The vacuum chamber has a 25 cm port to allow the solar flux to enter the chamber.
- The systems control computer and instrumentation system are located within the base.



IHRPT Solar Concentrator System Ground Demonstrator Base and Vacuum Chamber

Control and Data Acquisition System

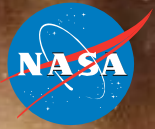

- The Control and Data Acquisition System uses a combination of software to compute the desired position of the actuators and sensors to determine any error from the desired position and the actual position. Corrections are then provided to the actuators to zero the error.
- The system tracks the sun in operation to within 0.1° . This is necessary because of the high (2400X) concentration ratio of the solar concentrator assembly.

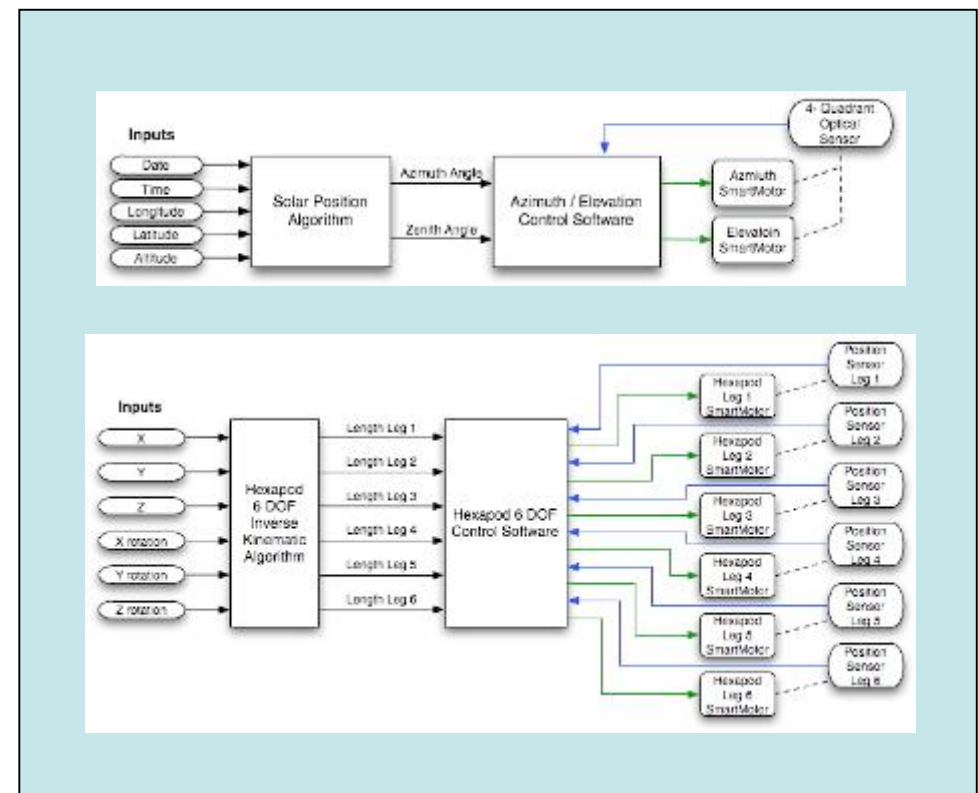

Control and Data Acquisition Flow Diagram

Graphical User Interface

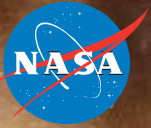

- Engineers developing the control software chose a free, open source software system named Blender. Development functions provided by Blender include 3D modeling, animation, and a game engine with a Python Application Programming Interface (API).
- A Graphical User Interface was developed that allow a game controller to interface with the simulation model of the concentrator system for the control of the concentrator's position. Because of the software's integration the same input can control the actual hardware in parallel with the animation model.
- This capability allows all operations to be tested prior to activating the hardware without the chance of damaging the hardware.

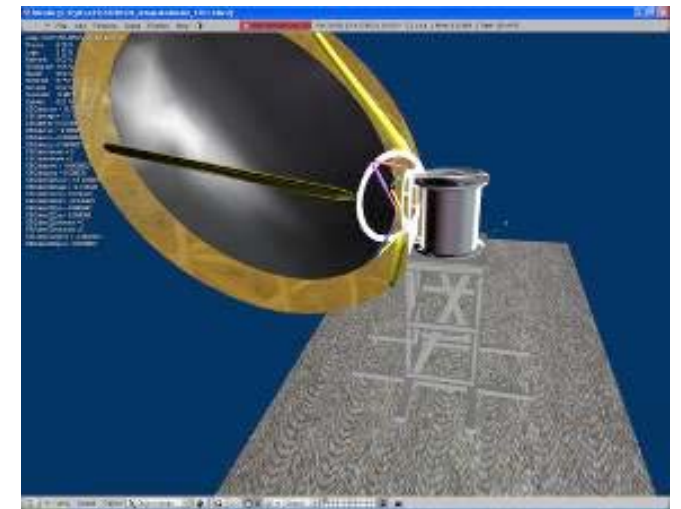
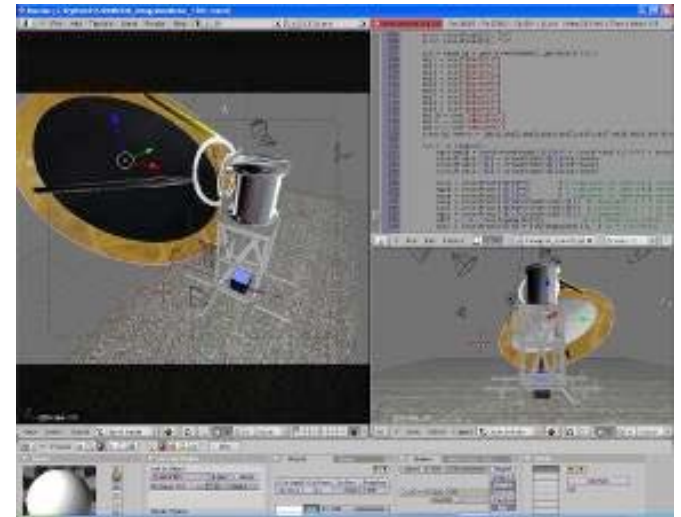

Graphical User Interface Screen Shots

Conclusion

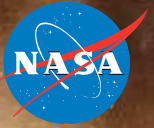

- The current status of the Portable Inflatable Solar Concentrator System is that all the major elements are ready for assembly and integration. The current schedule is to complete the integration activity by late November and begin check-out and performance testing in December. If there are no problems interfacing, processing experiments could start in the first quarter of calendar year 2009.