

~~CONFIDENTIAL~~
~~CLASSIFICATION CANCELLED~~

REC'D MAR 7 1952

Source of Acquisition
CASI Acquired

Released 3-12-82
PERMANENT FILE COPY

~~CLASSIFICATION CANCELLED~~

Authority NACA RESEARCH ABSTRACTS
and Reclassification Notice No. 14

~~CONFIDENTIAL~~
~~CLASSIFICATION CANCELLED~~

Date *2/5/57*

Restriction/Classification
Cancelled

RESEARCH MEMORANDUM

for the

Bureau of Aeronautics, Department of the Navy

FORCE CHARACTERISTICS IN THE SUBMERGED AND PLANING

CONDITION OF A $\frac{1}{5.78}$ - SCALE MODEL OF A HYDRO-SKI-

WHEEL COMBINATION FOR THE GRUMMAN

JRF-5 AIRPLANE

By Norman S. Land and Charles A. Pelz

Langley Aeronautical Laboratory
Langley Field, Va.

~~CONFIDENTIAL~~
~~CLASSIFICATION CANCELLED~~
~~CONFIDENTIAL~~
~~CLASSIFICATION CANCELLED~~

This memorandum is classified "CONFIDENTIAL" within the meaning of the espionage laws, Title 18, U.S.C., Secs. 793 and 794, the transmission or revelation of which in any manner to an unauthorized person is prohibited by law.

NATIONAL ADVISORY COMMITTEE FOR AERONAUTICS

WASHINGTON

MAR 5 1952

FILE COPY

To be returned to
the files of the National
Advisory Committee
for Aeronautics
Washington, D. C.

~~CONFIDENTIAL~~
~~CLASSIFICATION CANCELLED~~

①
1/1

CONFIDENTIAL
CLASSIFICATION CANCELLED

NATIONAL ADVISORY COMMITTEE FOR AERONAUTICS

RESEARCH MEMORANDUM

for the

Bureau of Aeronautics, Department of the Navy

FORCE CHARACTERISTICS IN THE SUBMERGED AND PLANING

CONDITION OF A $\frac{1}{5.78}$ -SCALE MODEL OF A HYDRO-SKI-

WHEEL COMBINATION FOR THE GRUMMAN

JRF-5 AIRPLANE

TED NO. NACA DE 357

By Norman S. Land and Charles A. Pelz

SUMMARY

Force characteristics determined from tank tests of a $\frac{1}{5.78}$ -scale model of a hydro-ski-wheel combination for the Grumman JRF-5 airplane are presented. The model was tested in both the submerged and planing conditions over a range of trim, speed, and load sufficiently large to represent the most probable full-size conditions.

INTRODUCTION

The Bureau of Aeronautics, Department of the Navy, is currently engaged in a program of tests to determine the performance and handling characteristics of aircraft equipped with hydro-skis. The first research airplane was a Grumman JRF-5 airplane fitted with a single main hydro-ski. As a further step in the program it is planned to conduct tests on a JRF-5 equipped with twin hydro-skis. Because of beaching difficulties with the first research airplane, the use of integral beaching wheels in the skis of the latter airplane is being considered. Since no information is known to be available on the force characteristics of hydro-skis with protruding wheels, the Bureau of Aeronautics requested that the National Advisory Committee for Aeronautics conduct tank model tests of the hydro-ski-wheel configuration contemplated for the airplane. Because of the immediate need of the contractor for the results of the tank tests, these results are presented without analysis or discussion.

CLASSIFICATION CANCELLED
CONFIDENTIAL

MODELS AND APPARATUS

A general arrangement of the model ($\frac{1}{5.78}$ scale) is given in figure 1. The strut section and its ordinates are presented in figure 2. Table I gives the offsets for the hydro-ski. The protruding part of each wheel was simulated by attaching blocks of the proper shape to the basic ski. Only the protruding part was represented, as in the full-size ski the manufacturer intends to seal the gap between wheel and ski. Information on the form and arrangement of the ski, strut, and wheels was obtained from the Edo Aircraft Corporation.

For the planing tests the model was towed with freedom only in draft, the desired load on the water being set by counterbalancing. The model was attached to the carriage by means of a towing staff of rectangular section which was free to move vertically in a system of guide rollers. The horizontal force on the roller cage (resistance of the model) was measured by a spring and strain-gage arrangement. Trimming moment was measured by a dynamometer equipped with a spring and strain gage located at the bottom of the staff. Draft was indicated by the vertical position of the staff.

For the submerged tests the same apparatus was used except that restraint in draft was provided. This restraint was a strain-gage-equipped spring which enabled the measurement of the lift.

A windscreen was mounted on the carriage just forward of the model. With this arrangement all aerodynamic tares on the towing gear were determined to be negligible within the range of the tests.

PROCEDURE

In the planing condition the model was run both with and without wheels over a range of speed, load, and trim which is believed to be sufficiently large to cover the probable take-off conditions.

In the submerged or semisubmerged condition the range of test conditions was based on unpublished results of tests made on a dynamic model of the JRF-5 with twin skis. This range was covered completely only with the wheels installed. A spot check of this model with the wheels removed showed that their effect was negligible.

On all the tests the trimming moments were measured about a convenient, arbitrary point above the model. From the measured data the trimming moment was calculated about the point shown on figure 1.

RESULTS

The results of the tests with the model planing on the surface are presented in figures 3 and 4. These figures are plots of resistance, draft, and trimming moment against speed with water-borne load and trim as parameters.

The results of the tests with the model in the submerged condition are given in figures 5 and 6. Resistance, lift, and trimming moment are plotted against speed with draft and trim as parameters. Under some conditions water did not follow over the upper surface of the ski but separated near the leading edge. The resulting sheet of water that was thrown upward and backward in some cases impinged on an attachment plate at the top of the strut. This condition is not representative of full size and measurements made with such a situation are denoted by flagged symbols on the plots. All the values given are for model size.

The quantities in the figures are defined as follows:

- (a) Resistance is the measured horizontal force in pounds.
- (b) Load is the unbalanced weight in pounds of the model and gear.
- (c) Lift is the measured vertical force in pounds and is called positive if the model is attempting to rise.
- (d) Trimming moment in inch pounds is the moment about the point 7.77 inches aft of the bow and 1.65 inches above the keel and is called positive if the bow is attempting to rise.
- (e) Draft is the vertical distance from the free-water surface to a point on the keel of the model at the step and is measured in inches.

(f) Trim is the angle in degrees between the keel of the model and a horizontal.

(g) Speed is the towing speed in feet per second.

Langley Aeronautical Laboratory
National Advisory Committee for Aeronautics
Langley Field, Va.

Norman S. Land

Norman S. Land
Aeronautical Research Scientist

Charles A. Pelz

Charles A. Pelz
Aeronautical Aerodynamics Research Intern

Approved:

John B. Parkinson

John B. Parkinson
Chief of Hydrodynamics Division

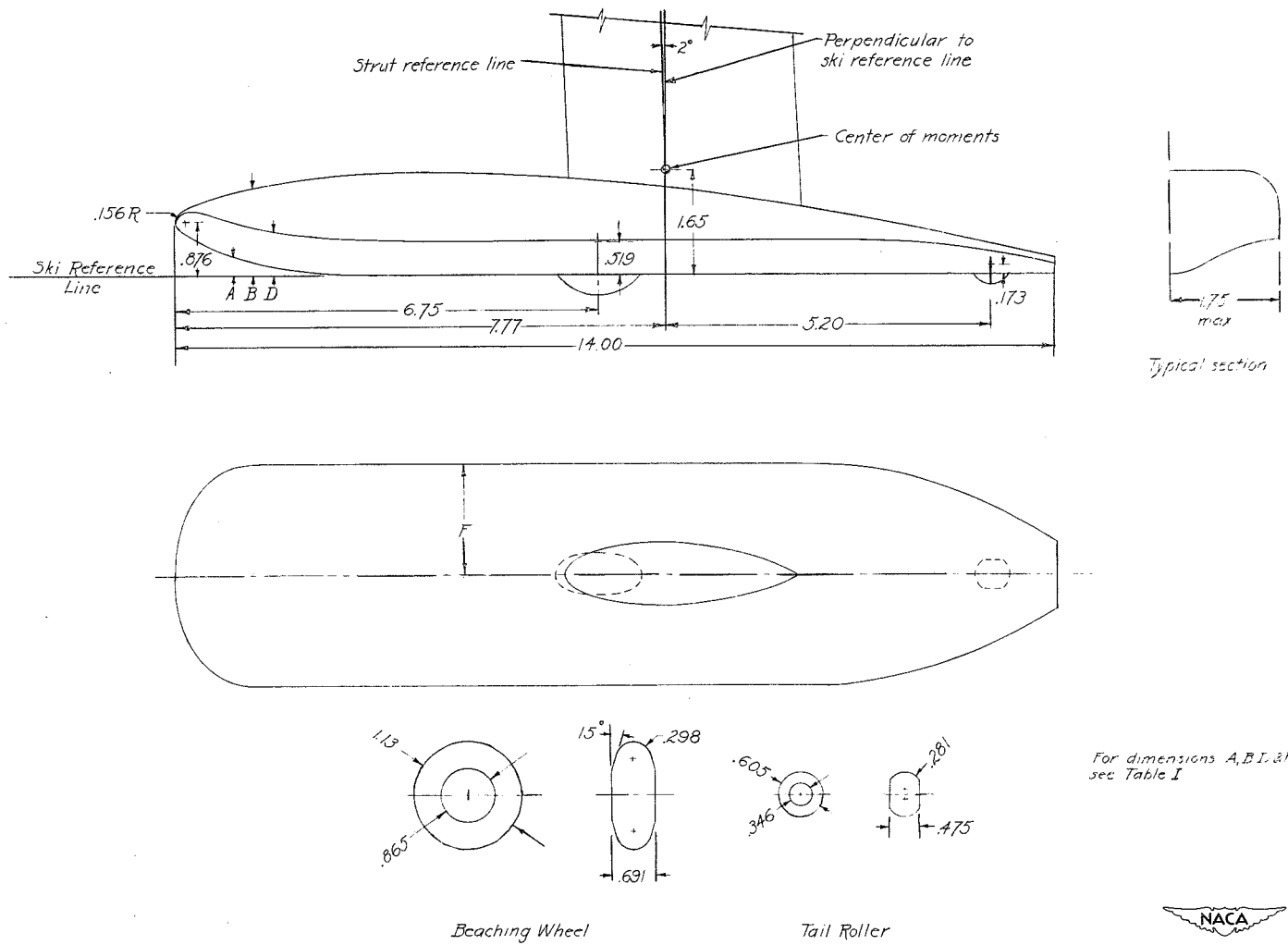
VR

TABLE I
HYDRO-SKI OFFSET TABLE

[All dimensions are in inches, model size]

Station	A	B	D	F
0	0.876	0.876	0.876	-----
.0625	-----	-----	.973	-----
.125	.704	1.03	1.01	-----
.25	.629	1.09	1.02	-----
.50	.496	1.18	.974	-----
1.0	.297	1.32	.828	-----
1.25	.222	1.37	.760	-----
1.50	.164	1.42	.704	1.75
2.50	.039	1.56	.579	1.75
3.38	.006	1.62	.546	1.75
3.75	.002	1.63	.542	1.75
4.20	0	1.63	.539	1.75
5.0	0	1.61	.539	1.75
5.38	0	-----	.539	1.75
6.26	0	1.54	.539	1.75
7.38	0	1.43	.539	1.75
9.38	0	1.18	.539	1.75
10.01	0	1.08	.539	1.75
10.64	0	.976	.538	1.74
10.88	0	.932	.534	1.72
11.26	0	.868	.529	1.66
11.89	0	.741	.504	1.56
12.45	0	.624	.454	1.28
12.51	0	.611	-----	-----
13.01	0	.497	.372	1.02
13.51	0	.378	.270	-----
14.00	0	.250	.136	.506

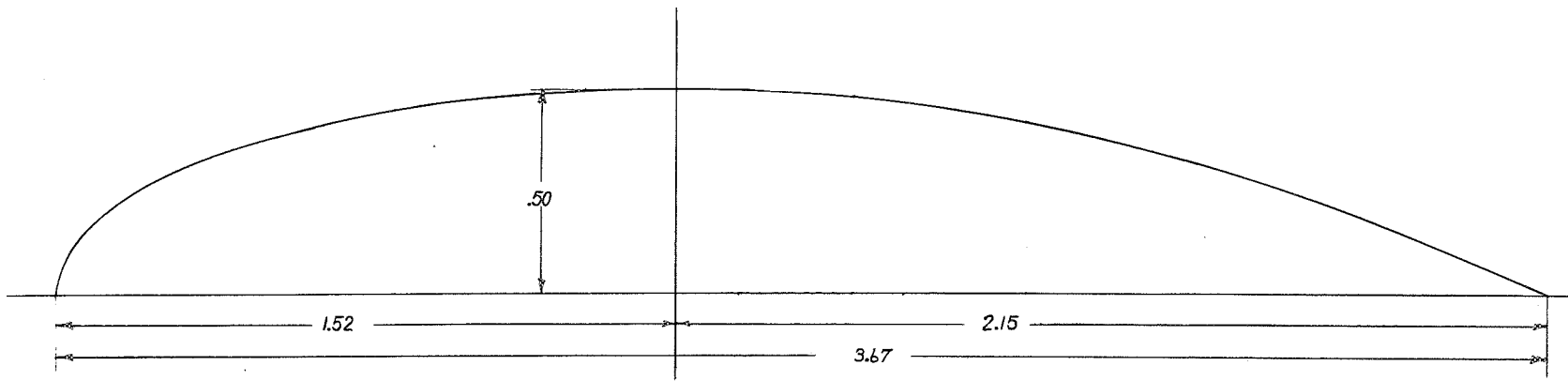
NACA



For dimensions A, B, I, & F see Table I



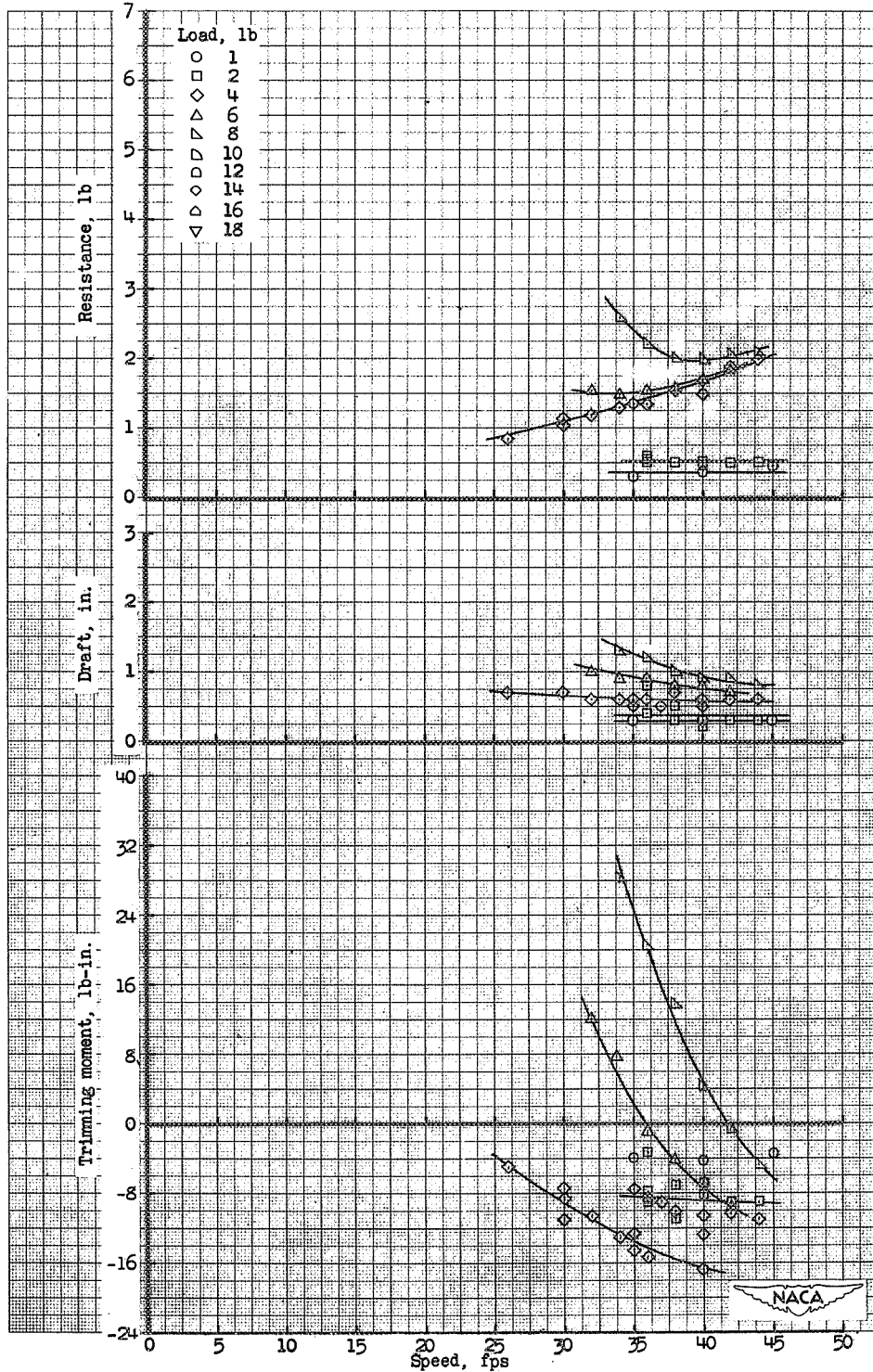
Figure 1.- General arrangement of $\frac{1}{5.78}$ - scale model of hydro-ski-wheel for Grumman JRF-5 with twin skis.



Station	Ordinate
0.0	.0
.02	.095
.126	.20
.30	.30
.55	.385
.84	.45
1.18	.485
1.53	.50
1.96	.48
2.38	.42
2.80	.32
3.24	.18
3.68	.00

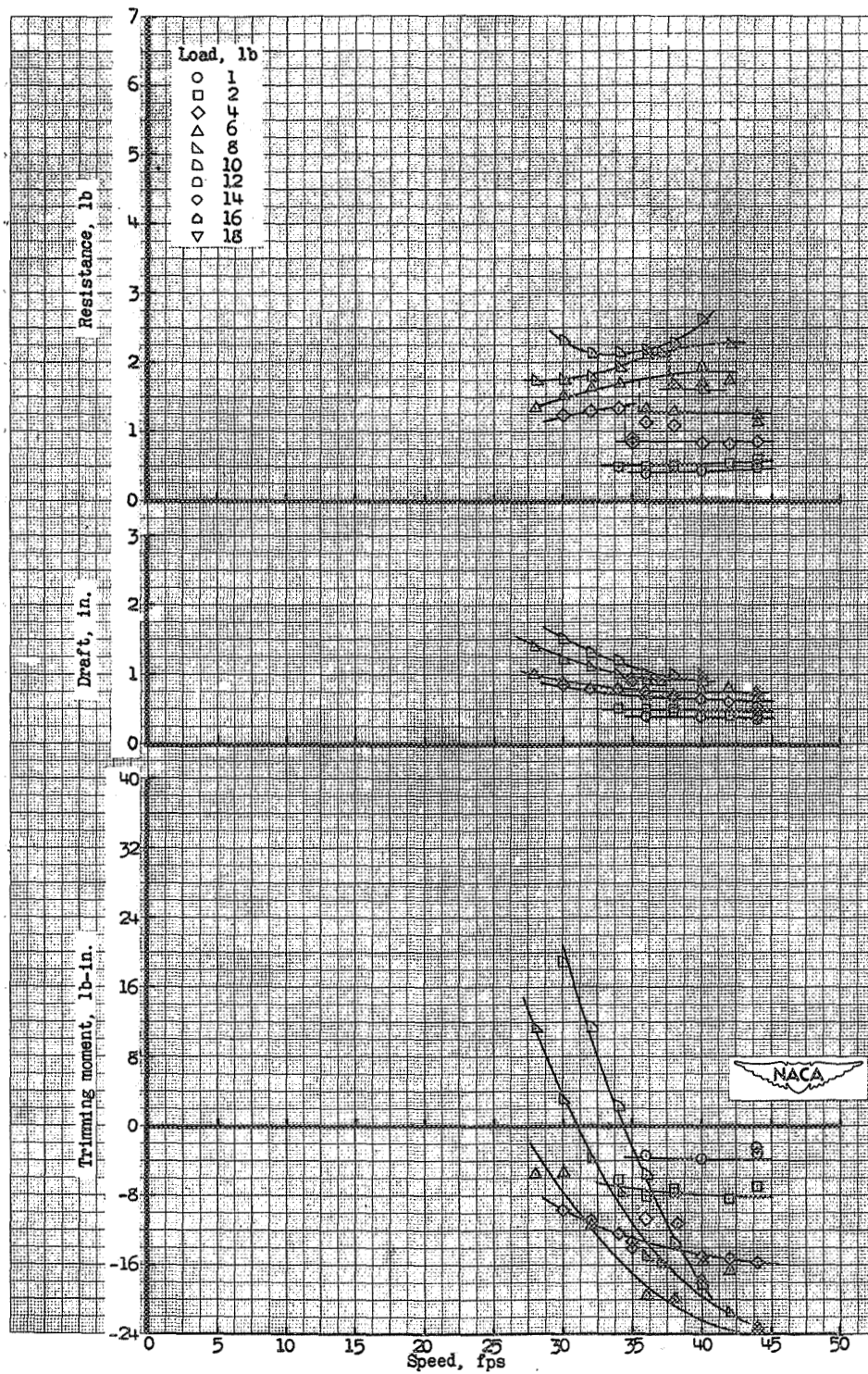


Figure 2.- Strut details. (All dimensions are in inches model size.)



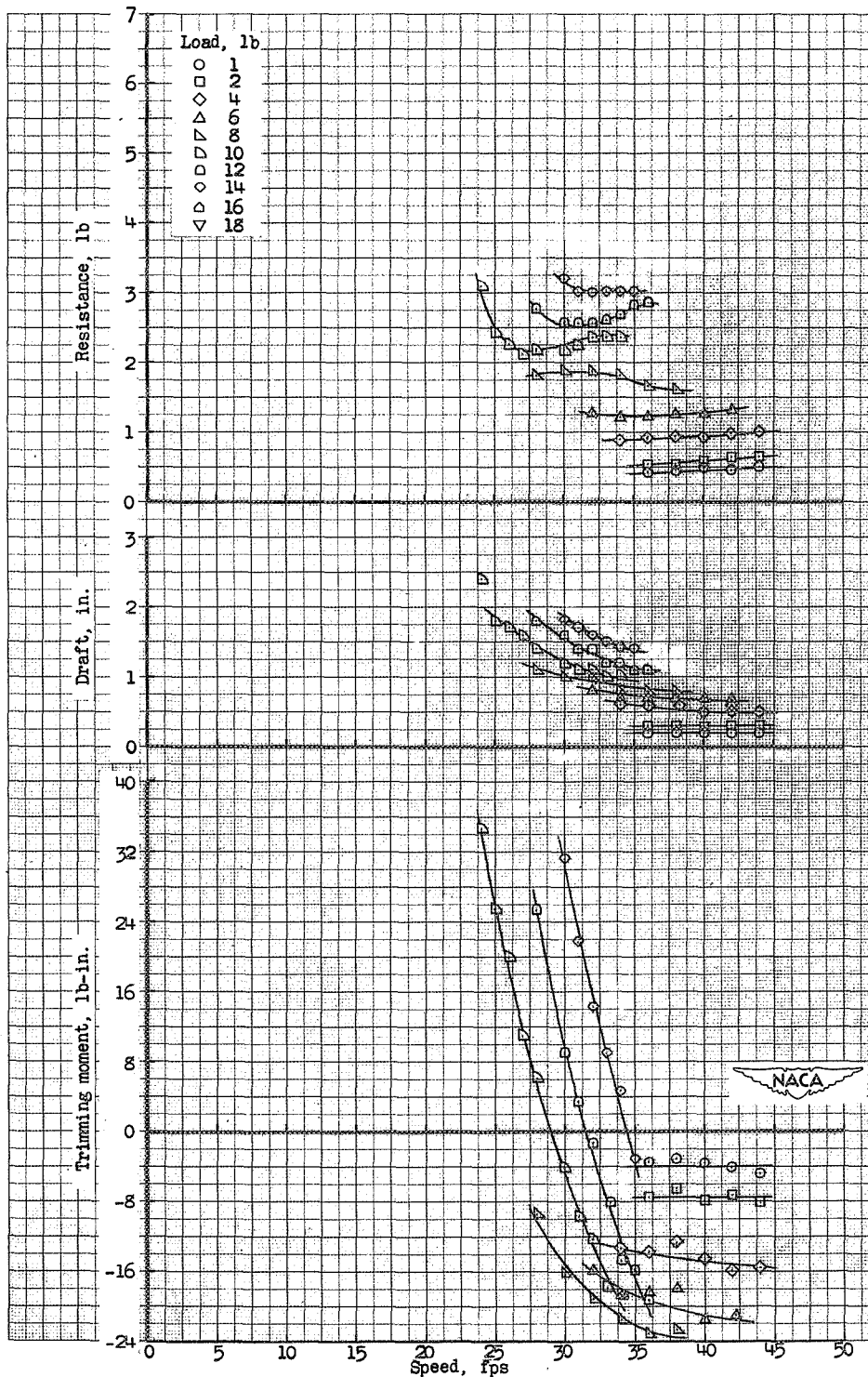
(a) Trim, 4°.

Figure 3.- Tank model 296; with wheels. Planing characteristics.



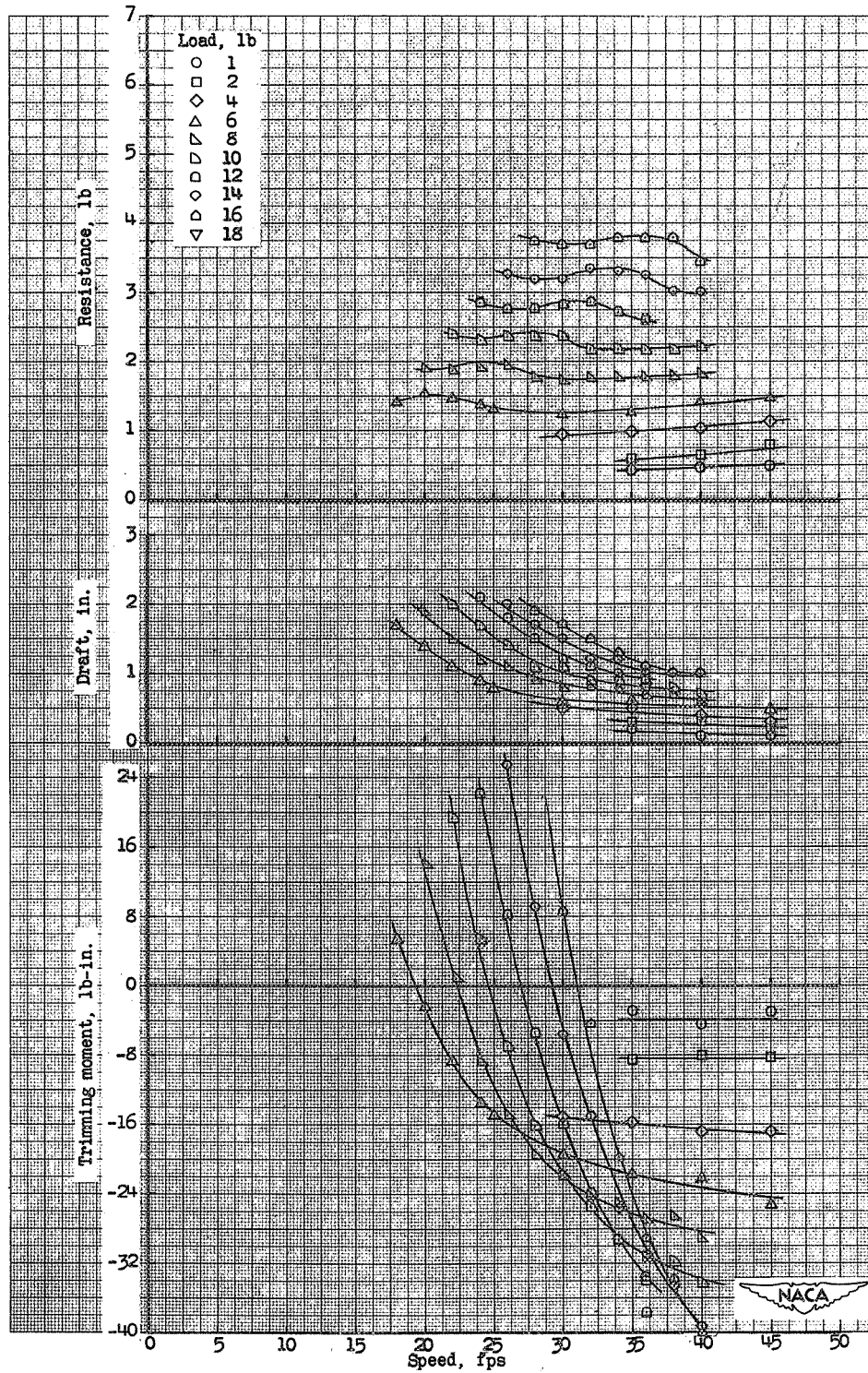
(b) Trim, 6°.

Figure 3.- Continued.



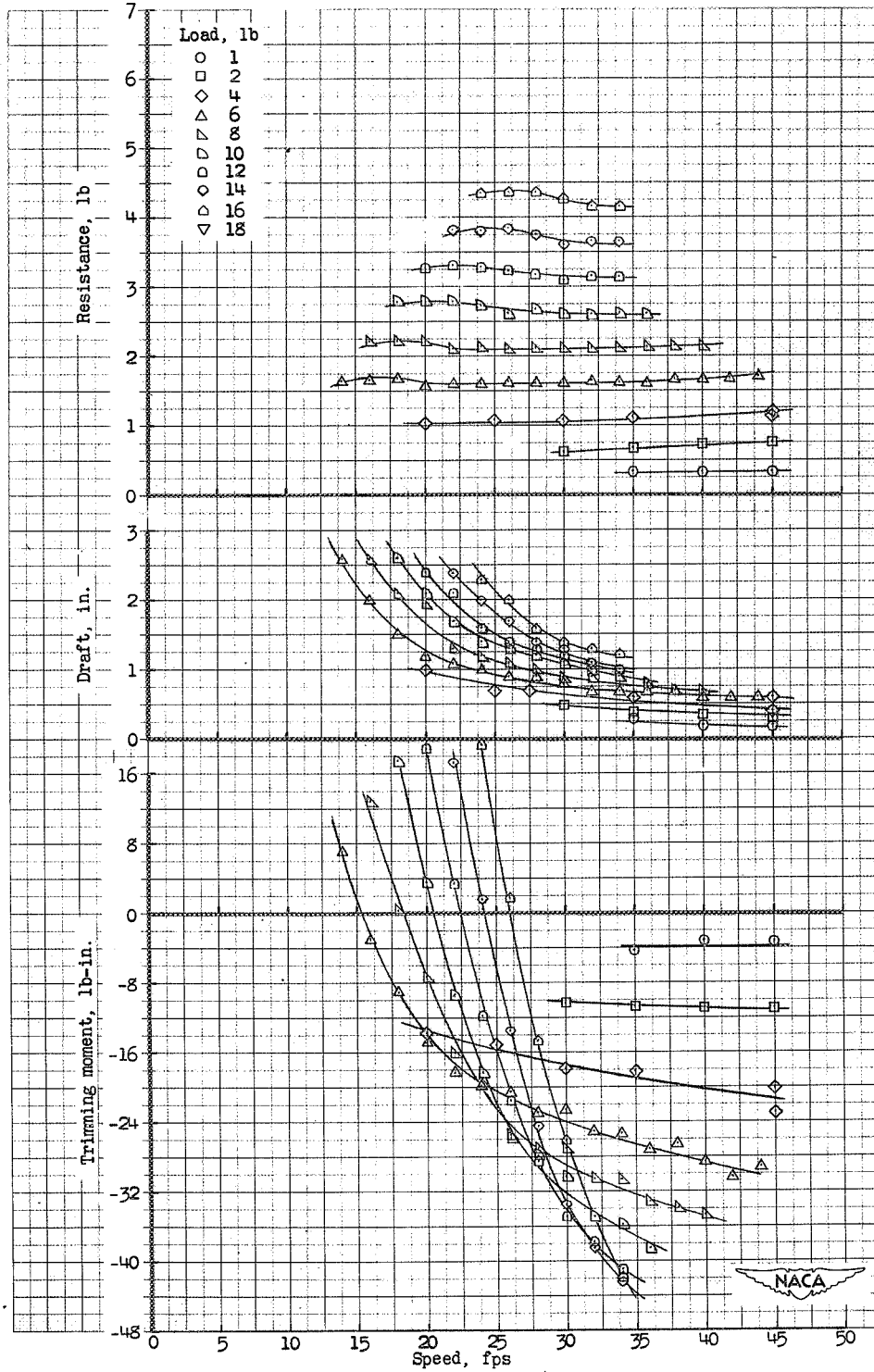
(c) Trim, 8°.

Figure 3.- Continued.



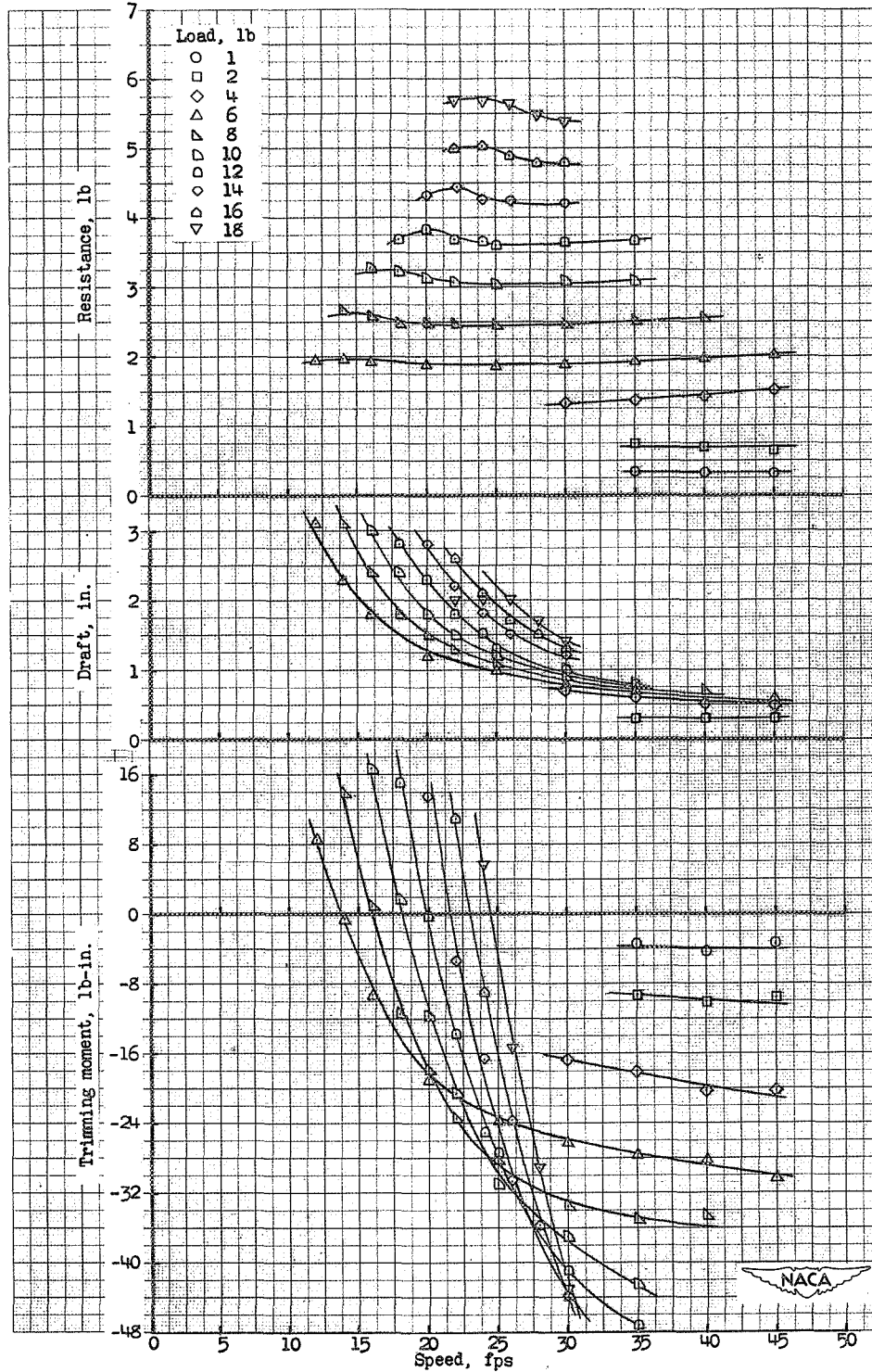
(d) Trim, 10°.

Figure 3.- Continued.



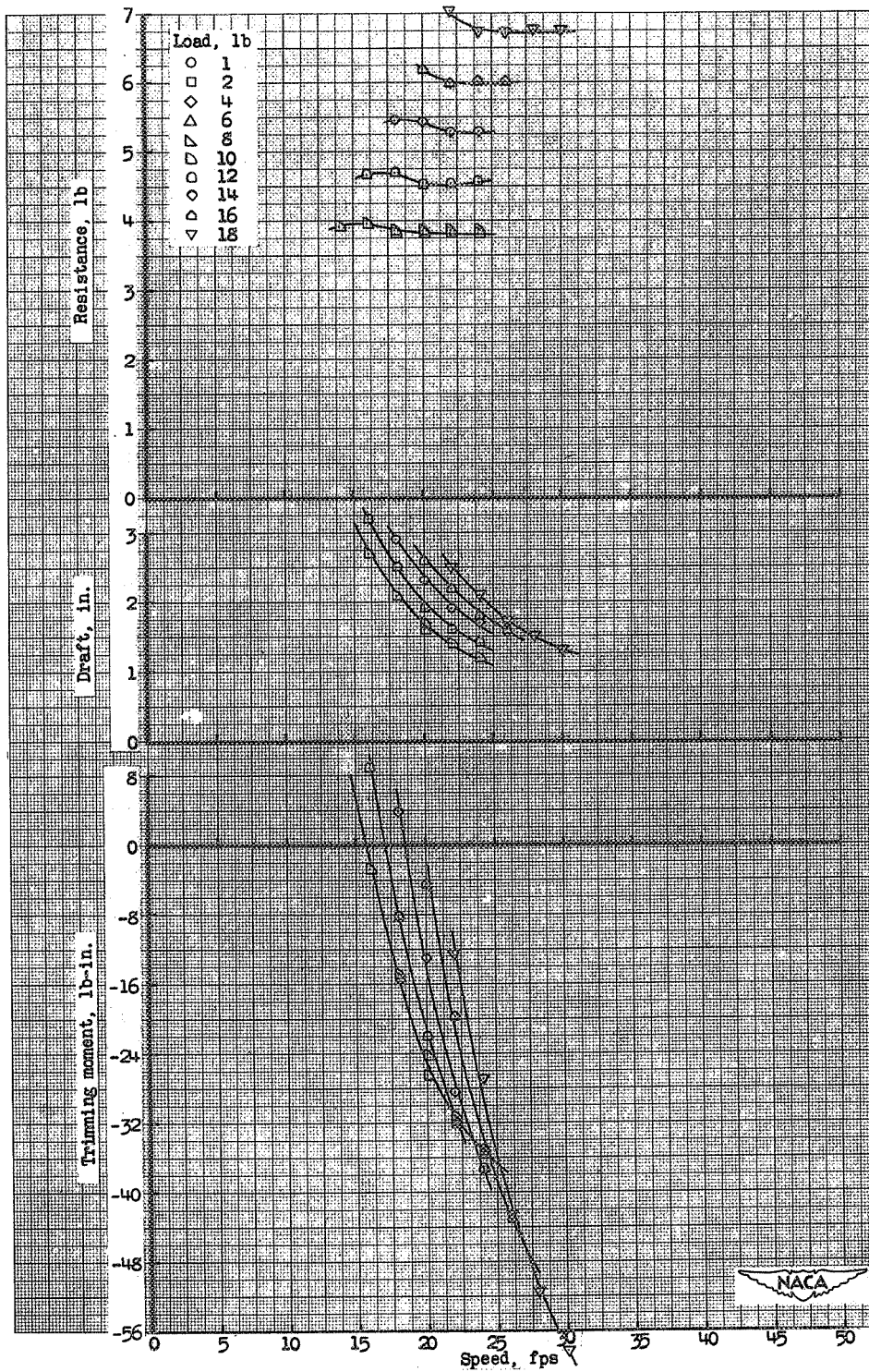
(e) Trim, 13°.

Figure 3.- Continued.



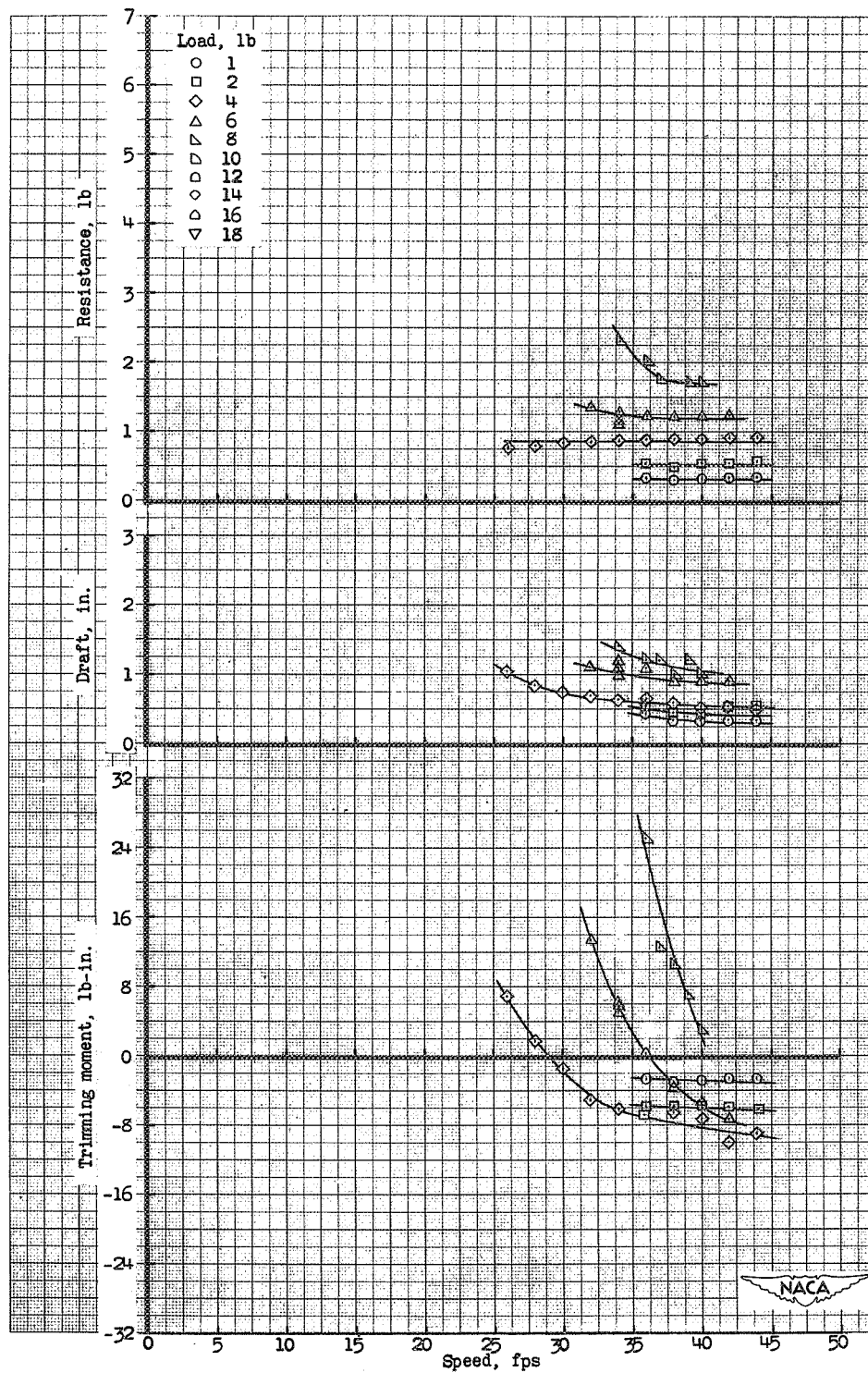
(f) Trim, 16°.

Figure 3.- Continued.



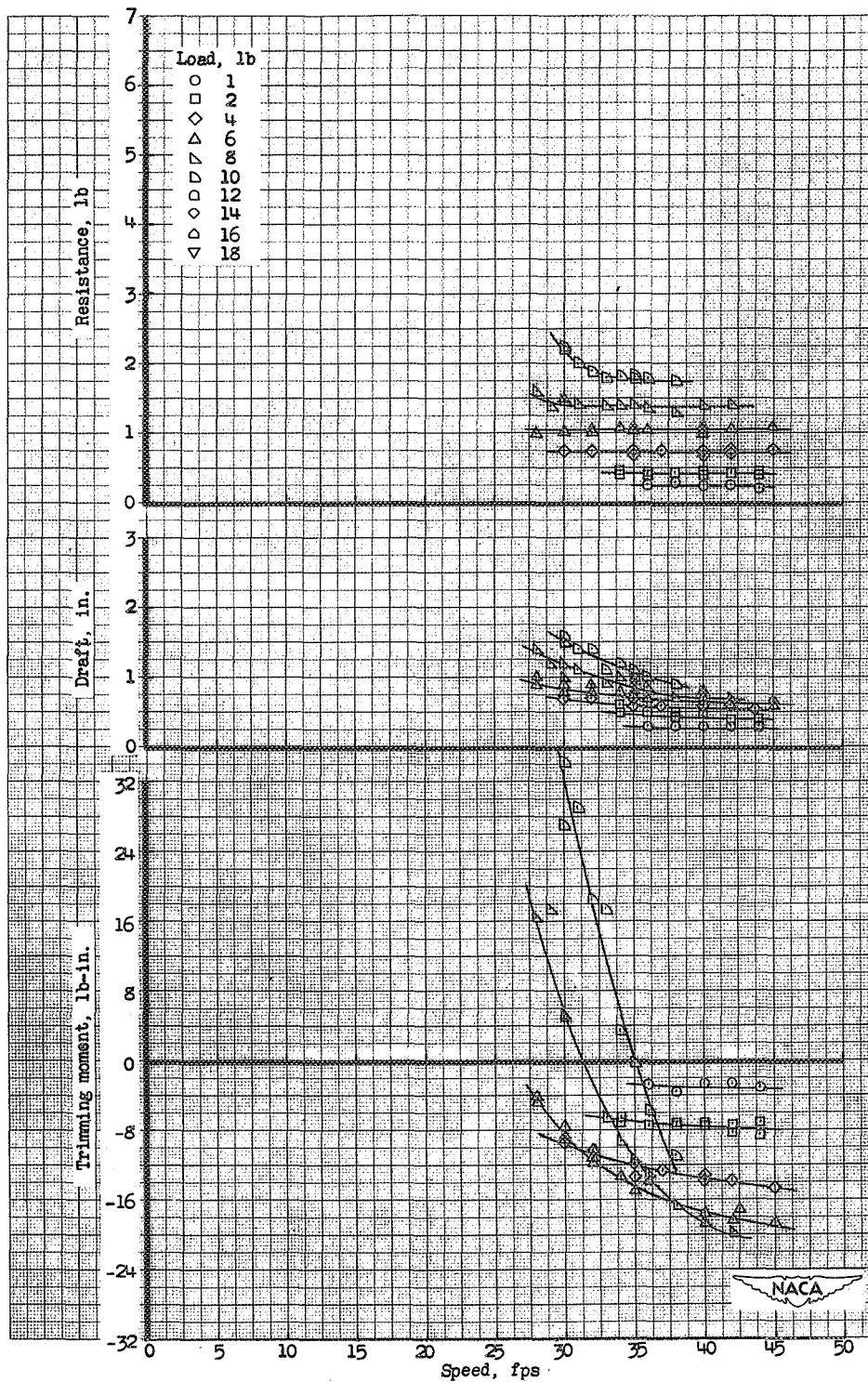
(g) Trim, 20°.

Figure 3.- Concluded.



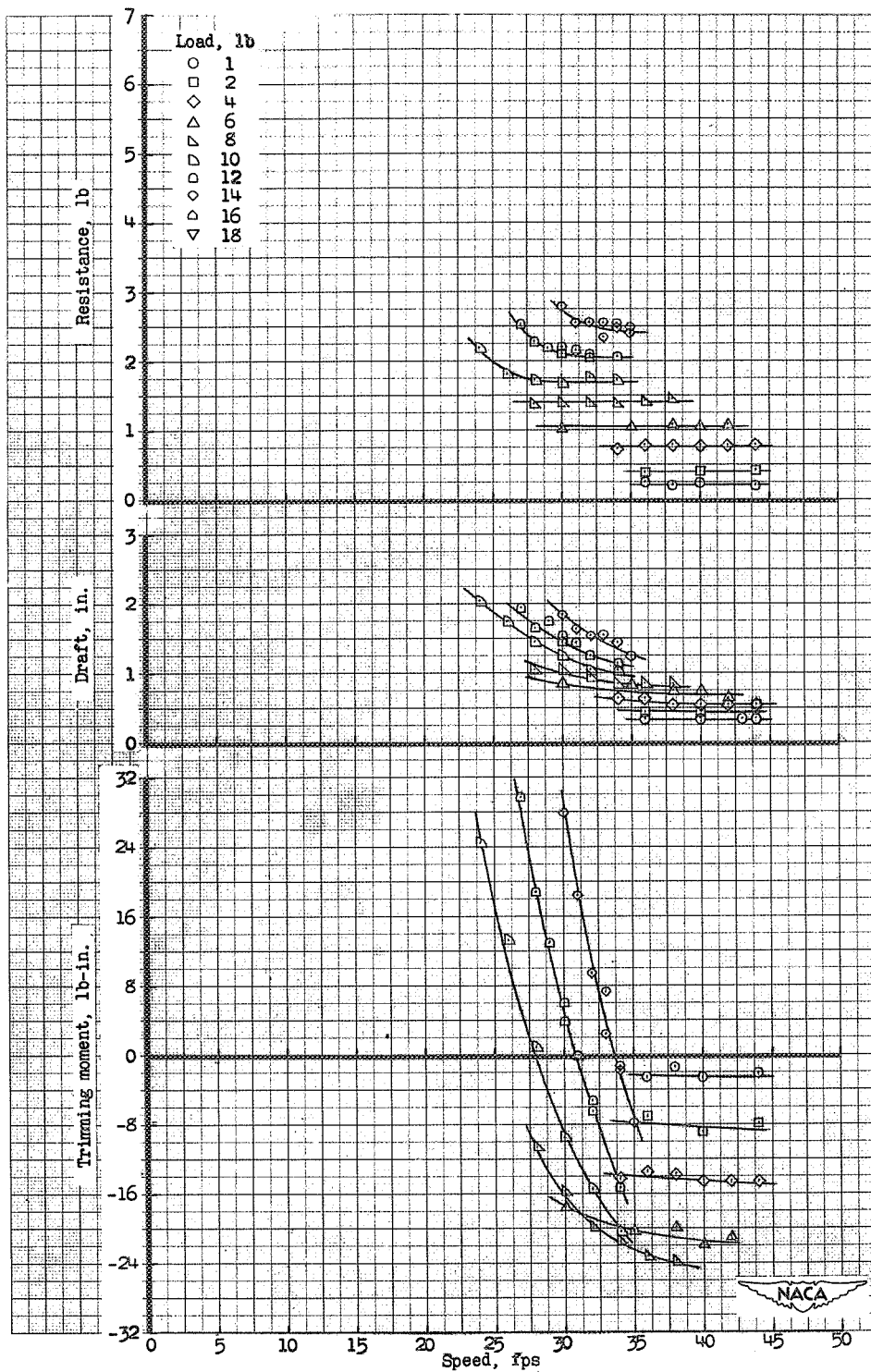
(a) Trim, 40.

Figure 4.- Tank model 296; no wheels. Planing characteristics.



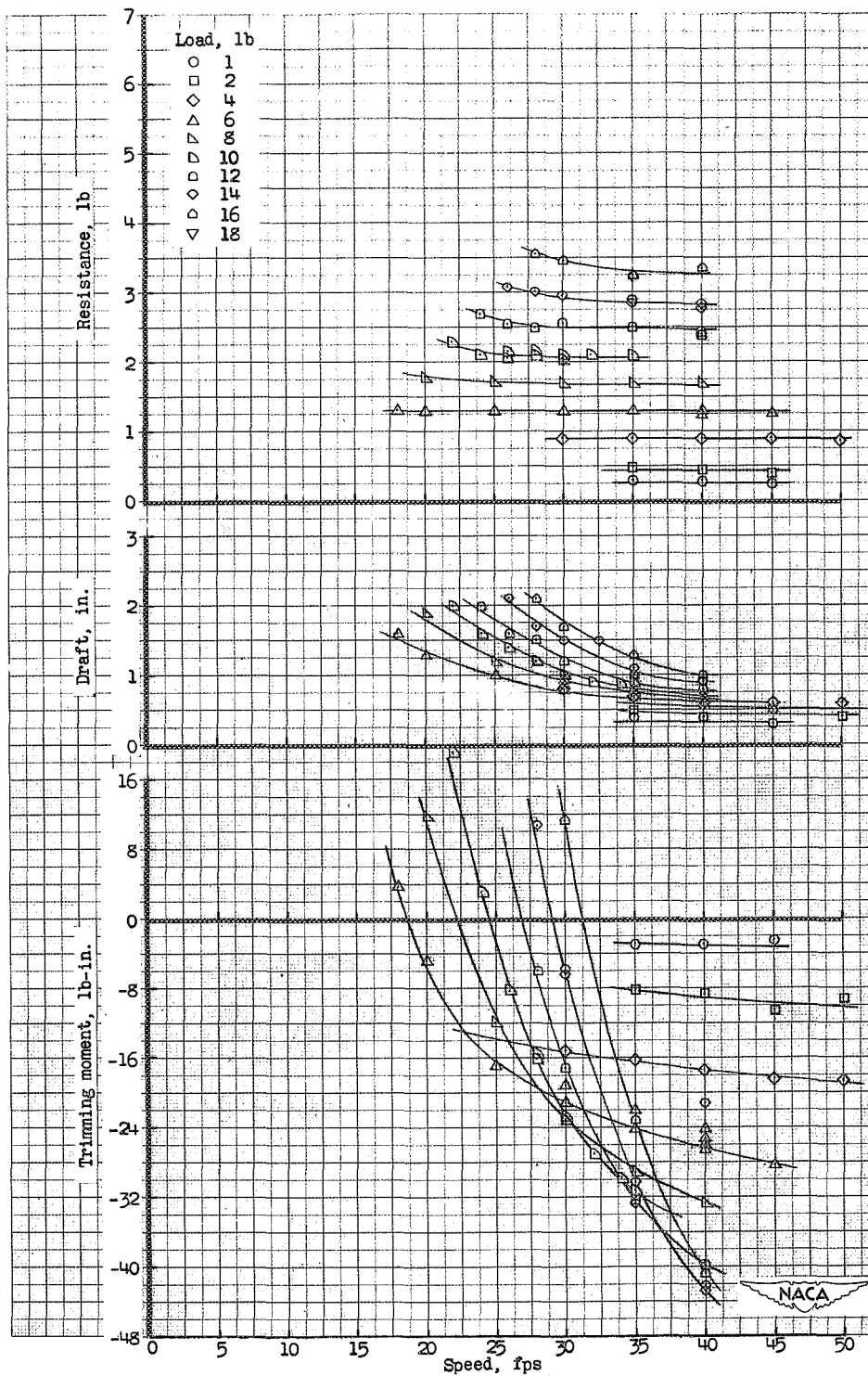
(b) Trim, 6°.

Figure 4.- Continued.



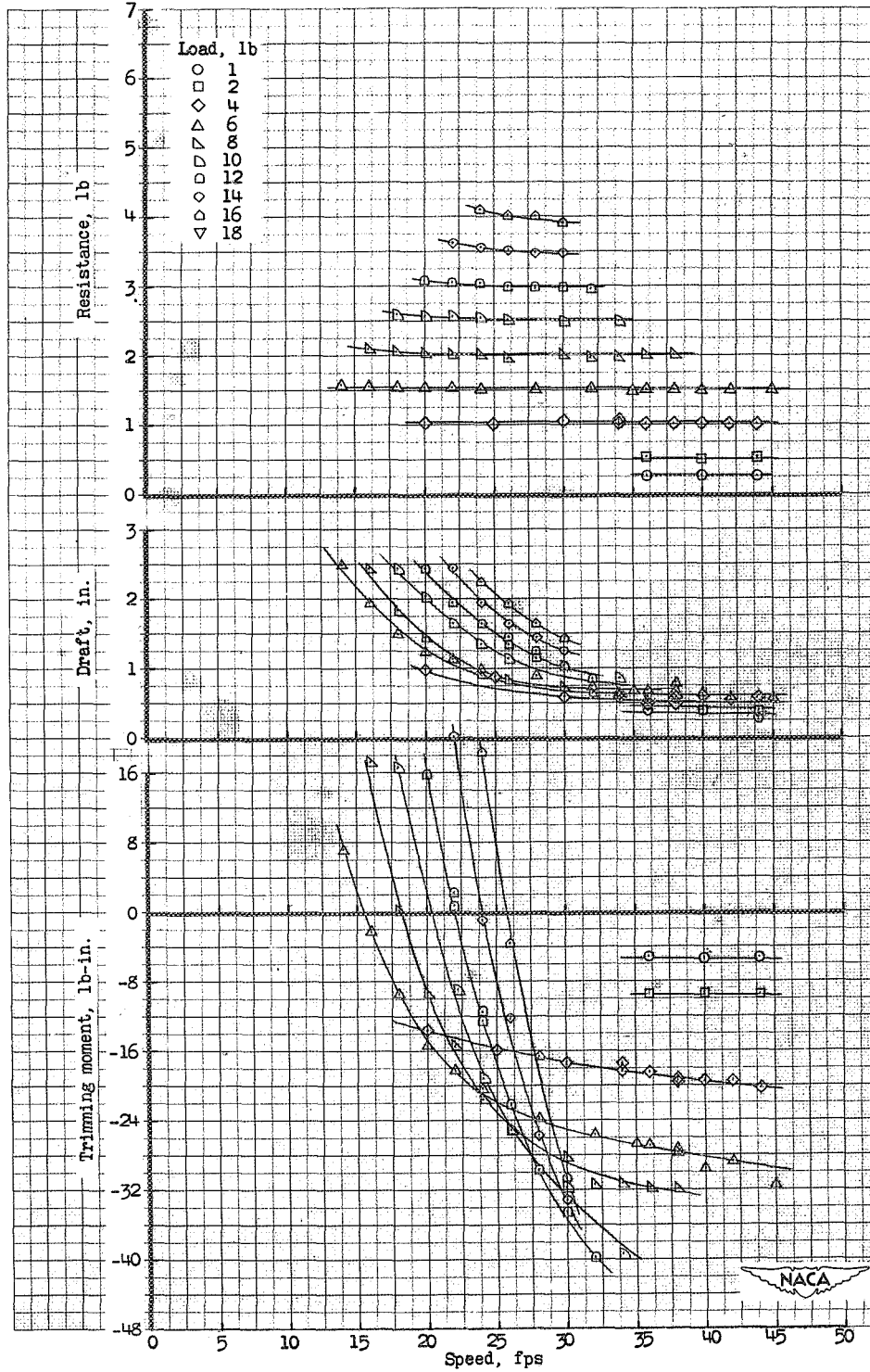
(c) Trim, 8°.

Figure 4.- Continued.



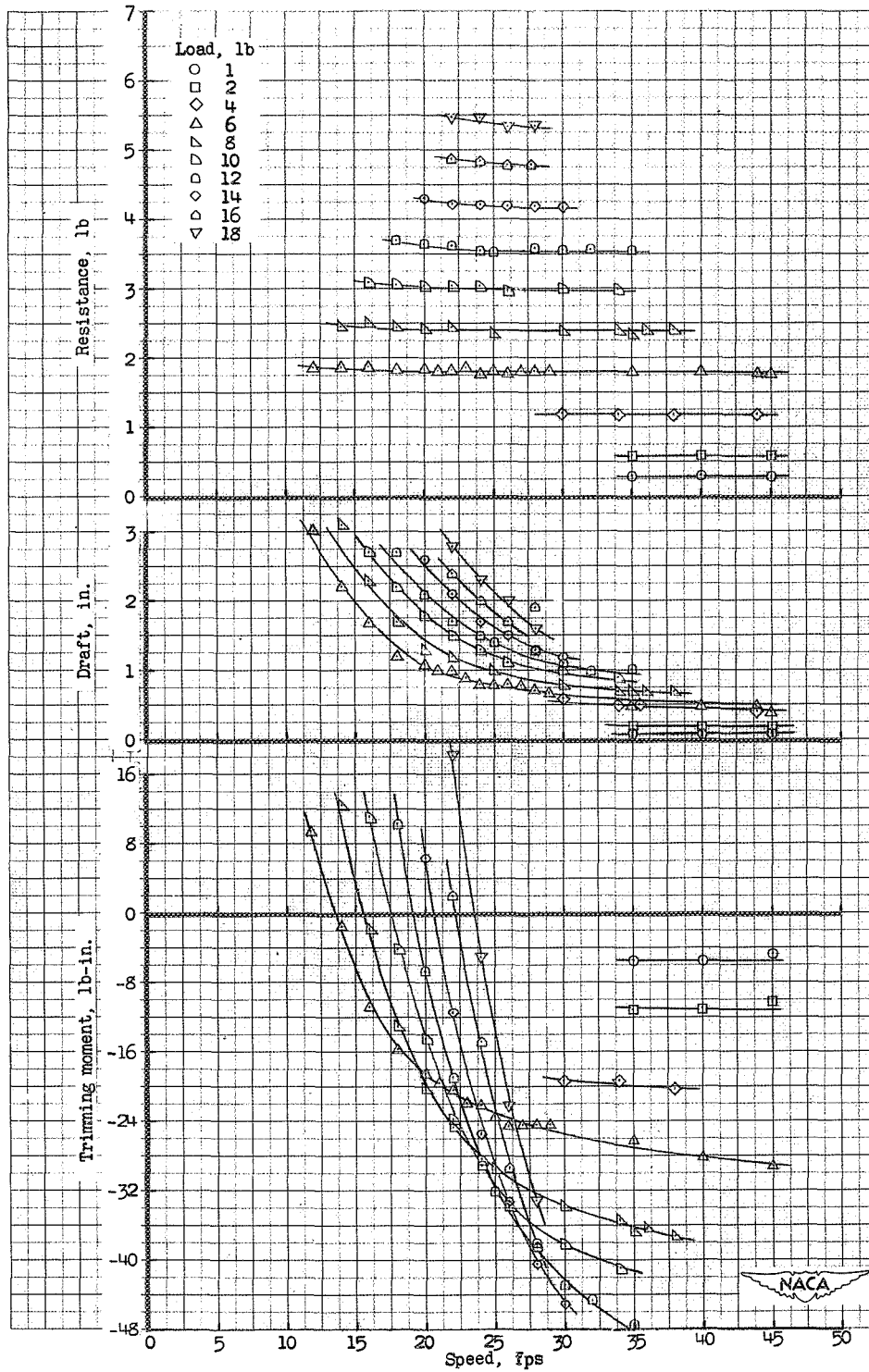
(d) Trim, 10°.

Figure 4.- Continued.



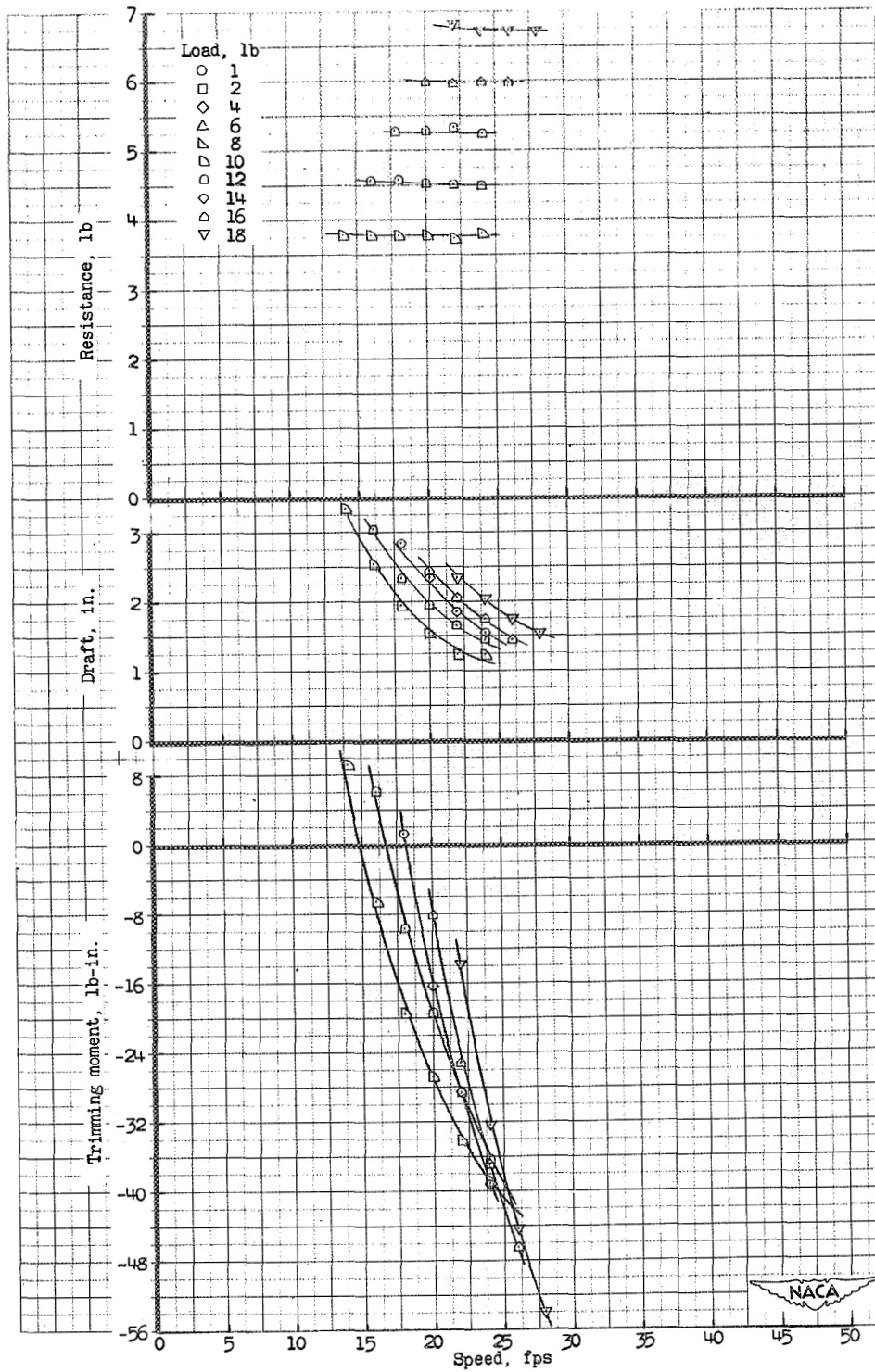
(e) Trim, 13°.

Figure 4.- Continued.



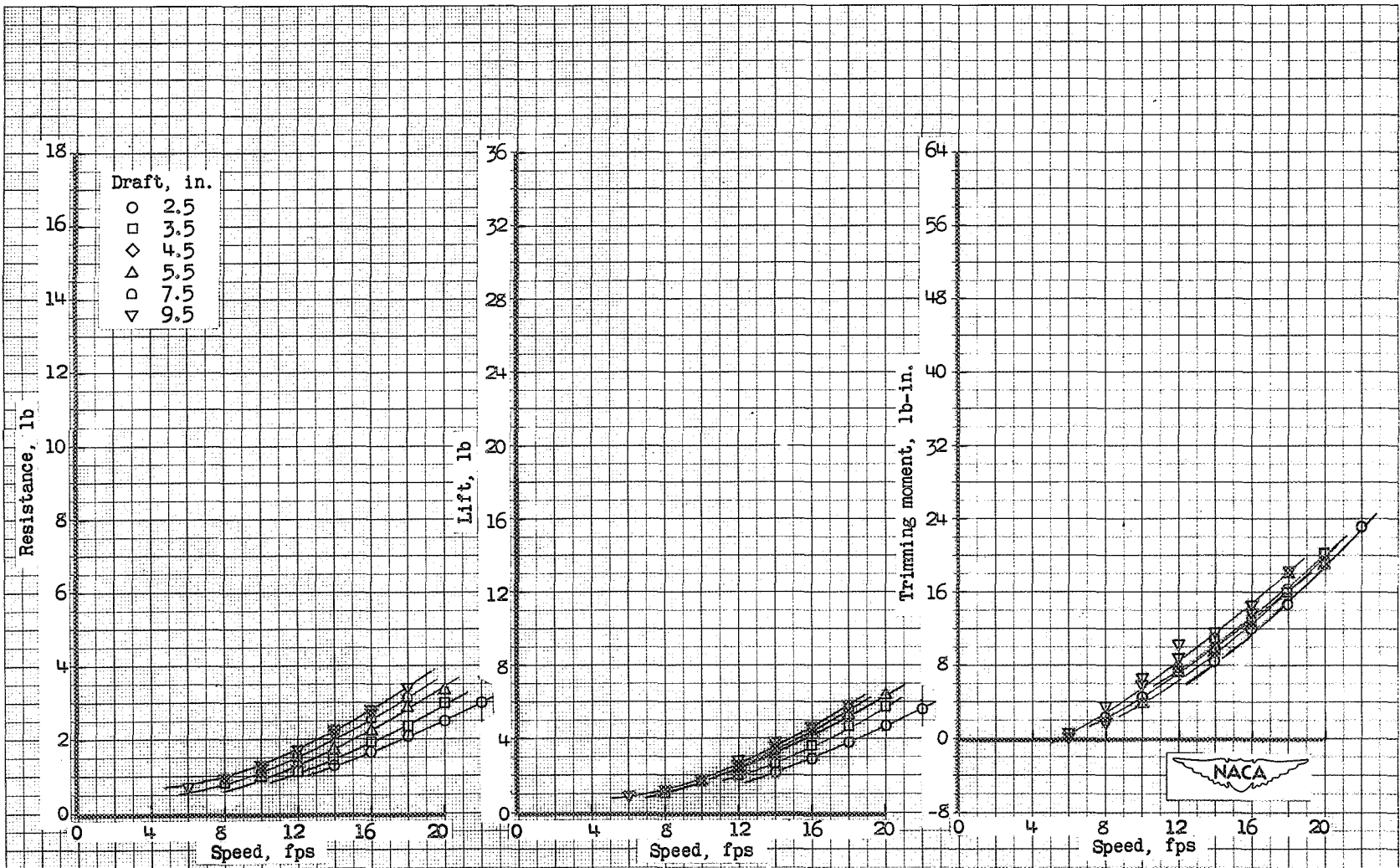
(f) Trim, 16°.

Figure 4.- Continued.



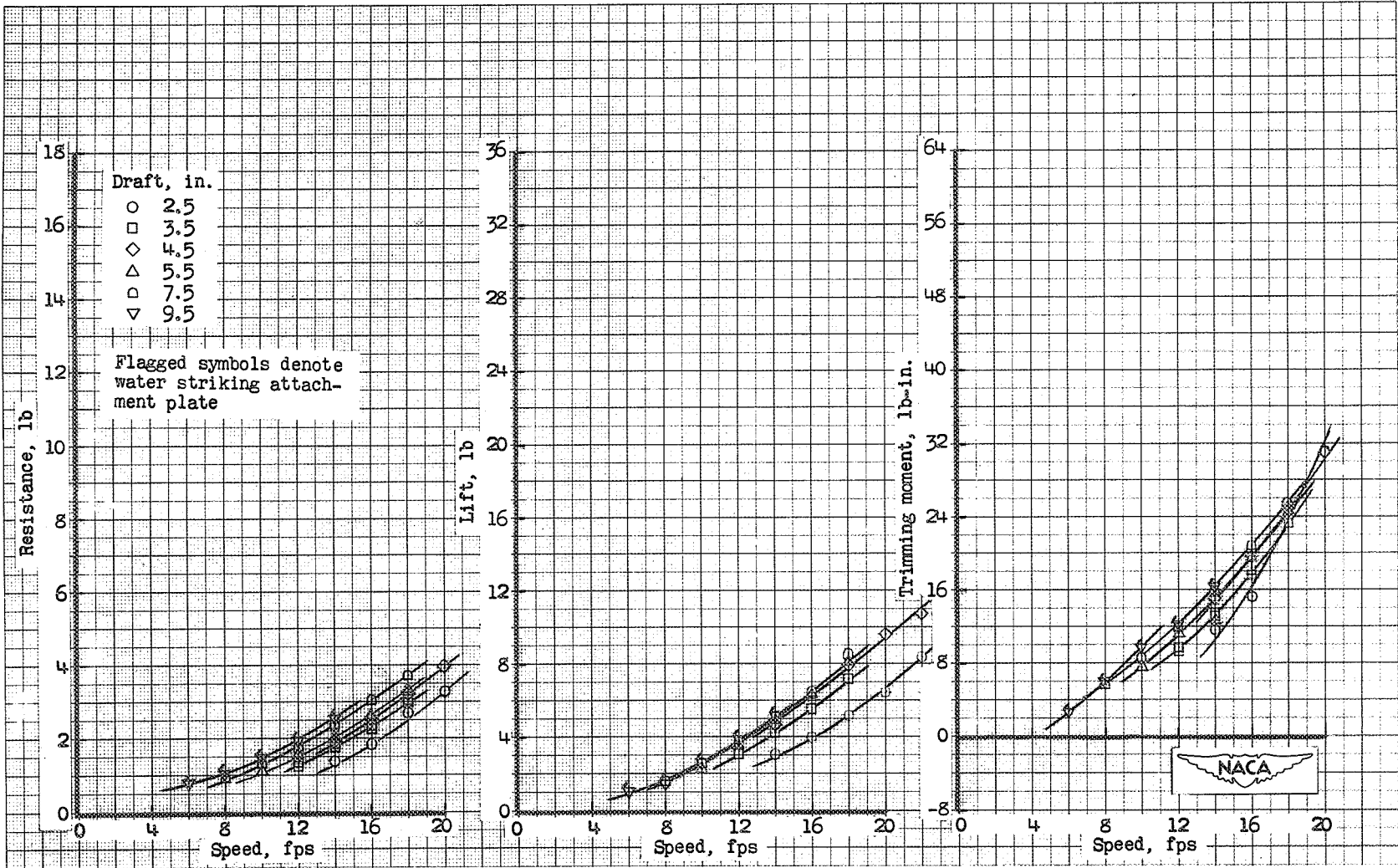
(g) Trim, 20°.

Figure 4.- Concluded.



(a) Trim, 4° .

Figure 5.- Tank model 296; with wheels. Submerged characteristics.



(b) Trim, 6°.

Figure 5.- Continued.

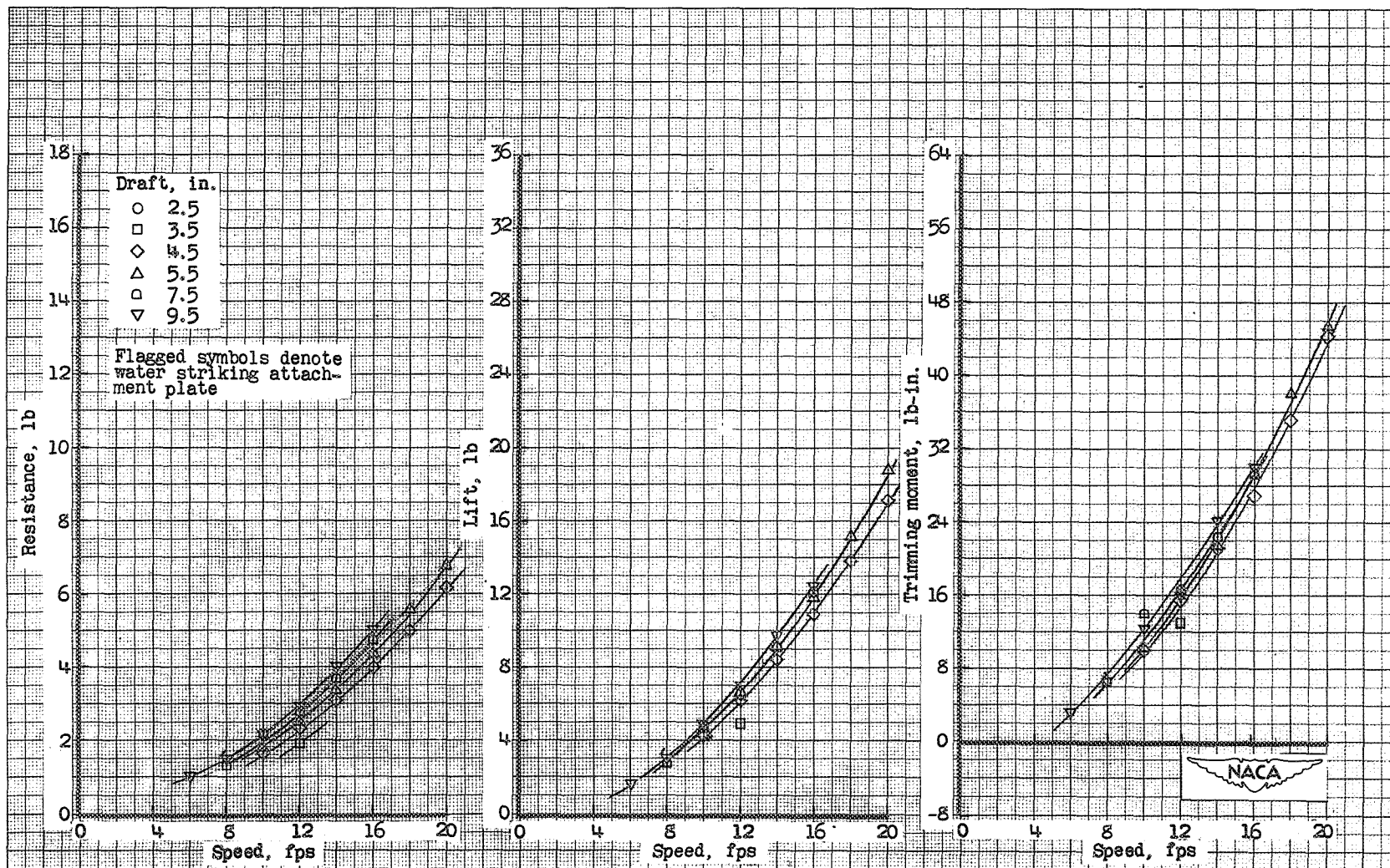
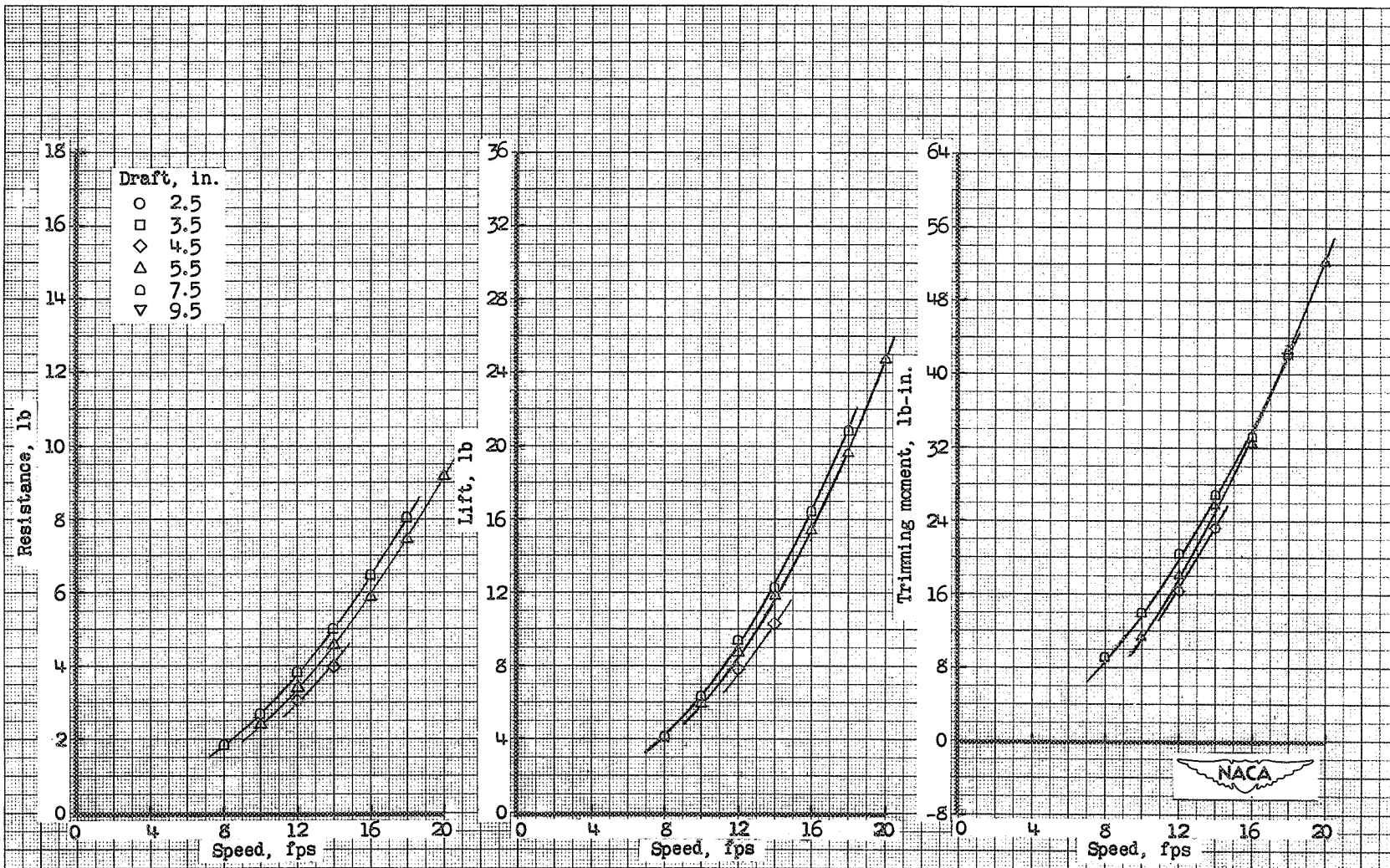
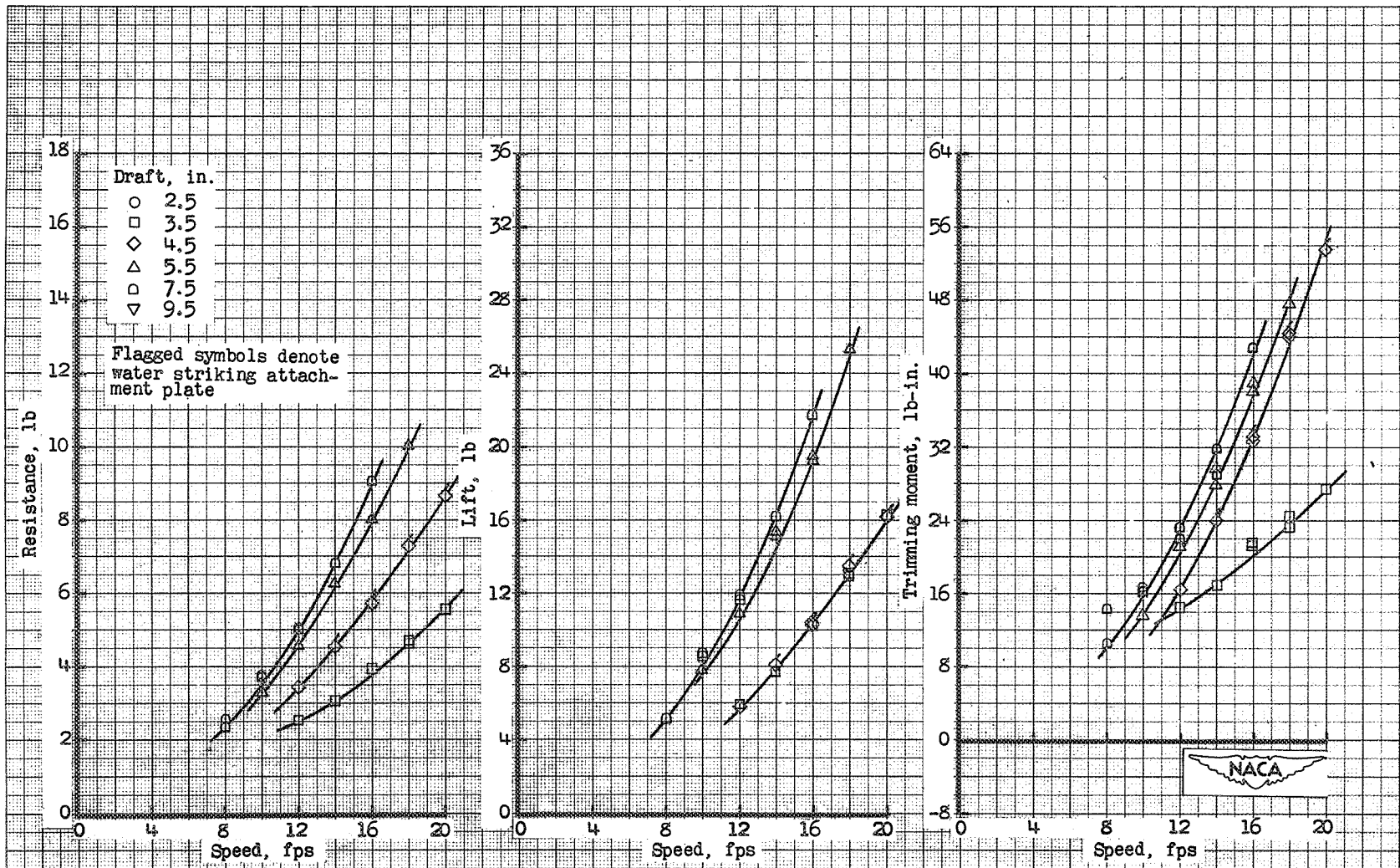
(c) Trim, 10° .

Figure 5.- Continued.



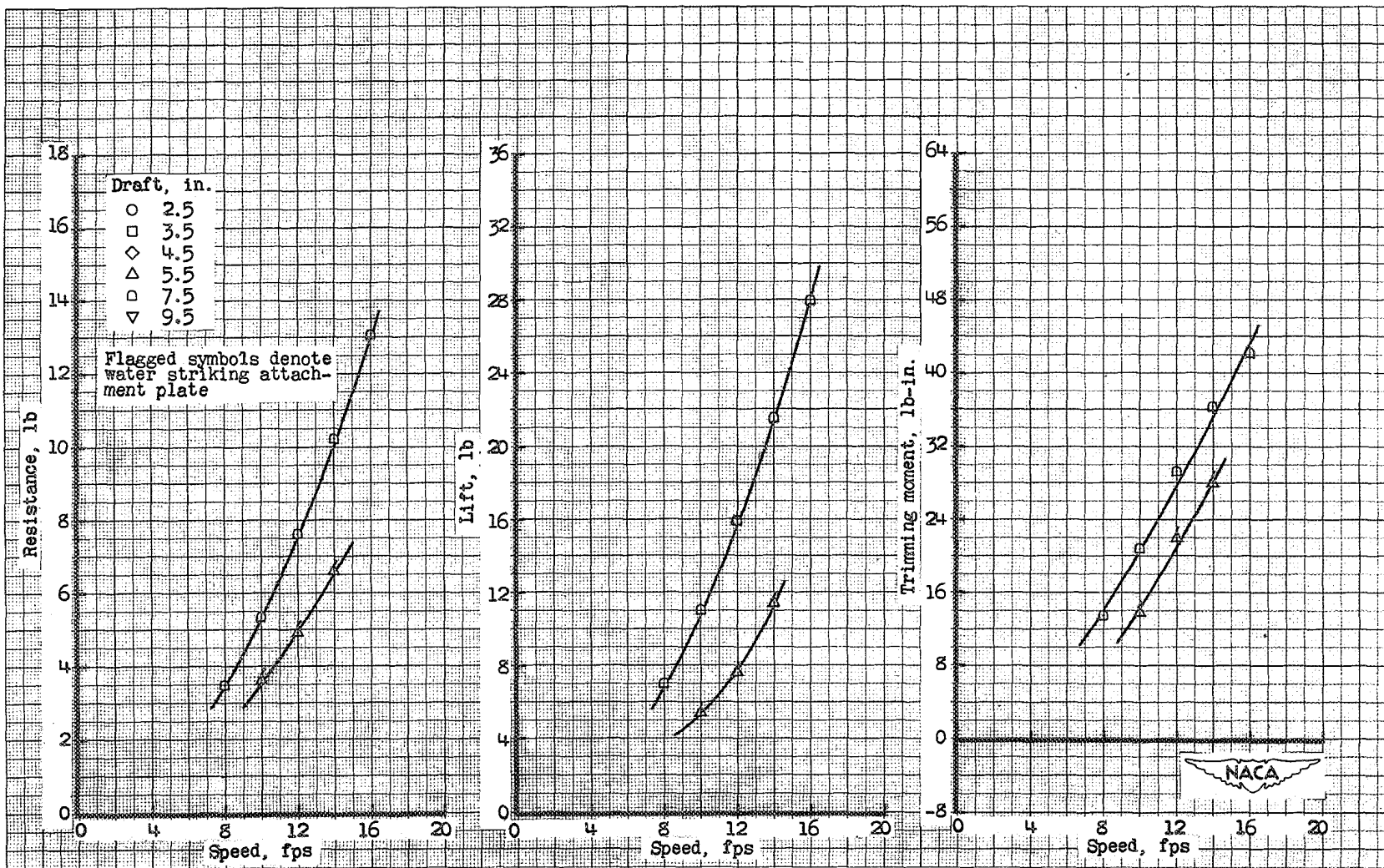
(d) Trim, 13°.

Figure 5.- Continued.



(e) Trim, 16° .

Figure 5.- Continued.



(f) Trim, 20°.

Figure 5.- Concluded.

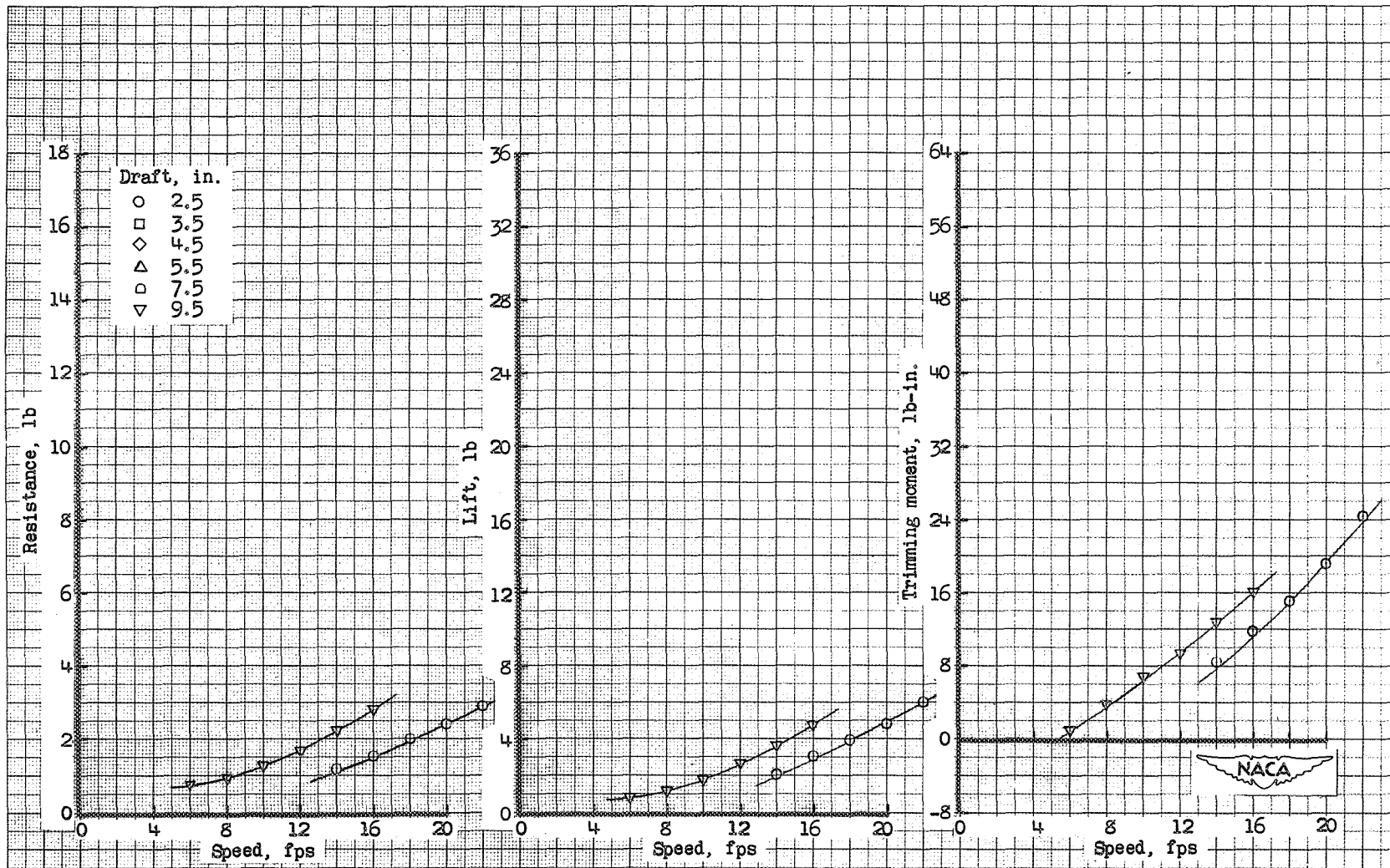
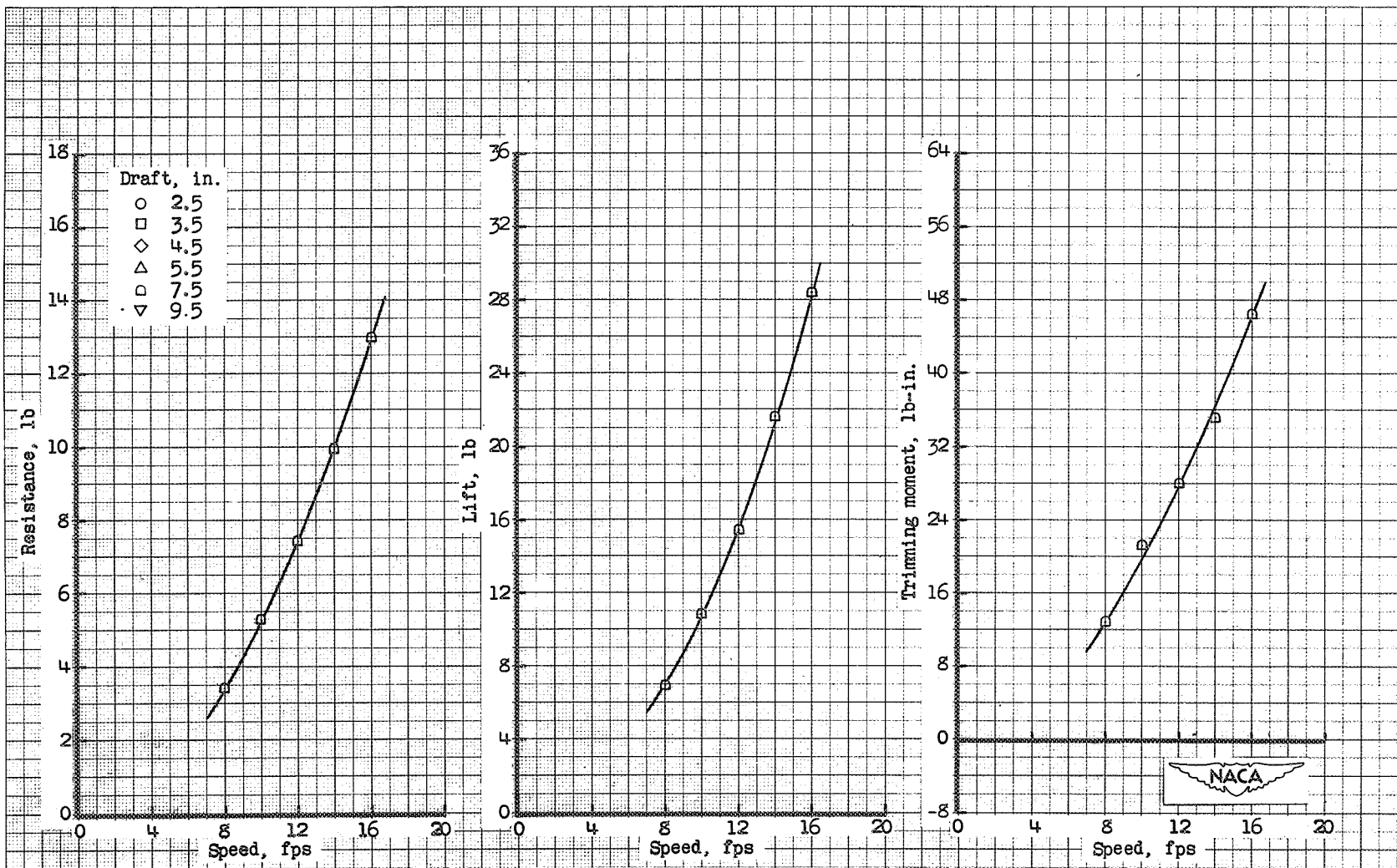
(a) Trim, 4° .

Figure 6.- Tank model 296; no wheels. Submerged characteristics.



(b) Trim, 20°.

Figure 6.- Concluded.