

literal function, that is the fundamental element in multi-valued logic.) Hence, the adjustable-threshold inverter can be made a basic building block of quaternary logic circuits.

The real-time-reconfigurable logic gate can be realized, in a circuit partly resembling the adjustable-threshold inverter, by applying the logic input signals to JG1 and JG2 and connecting the input terminal of what would otherwise be the inverter to a constant reference voltage (that is, making  $V_{in}$  a constant voltage). The number of transistors in this circuit is smaller than in a classical CMOS circuit that performs an equivalent logic function. The same hardware can be made to form any of three different functions: Depending on the value of  $V_{in}$ , the function is disabled output ( $V_{out} = V_{DD}$  or 0), the NOR of the logic levels represented by  $V_{JG1}$  and  $V_{JG2}$ , or

the NAND of the logic levels represented by  $V_{JG1}$  and  $V_{JG2}$ .

In the DRAM cell, the lateral inversion-mode PMOSFET (a MOSFET having a p-doped channel and an n-doped Si substrate) inherent in the n-channel  $G^4$ FET is used for writing data in the horizontal direction, while the p-channel JFET serves to read the data in the vertical direction. When the WWL signal turns on the PMOS switch, the potential of the storage node (SN) is modulated by WBL. When writing is disabled, SN is isolated, and during the retention time, its depletion region is more or less extended toward the body, depending on value of the datum stored in it. As a result, the resistance of the JFET channel in the vertical direction is affected, causing the sensing current ( $I_{sense}$ ) to be a function of the stored data. The sensing-current char-

acteristics can be optimized via the layout of the  $G^4$ FET structure.

*This work was done by Mohammad Mojaradi of Caltech; Kerem Akarvardar, Sorin Cristoleveanu, and Paul Gentil of Grenoble University; and Benjamin Blalock and Suhan Chen of University of Tennessee for NASA's Jet Propulsion Laboratory.*

*In accordance with Public Law 96-517, the contractor has elected to retain title to this invention. Inquiries concerning rights for its commercial use should be addressed to:*

*Innovative Technology Assets Management  
JPL*

*Mail Stop 202-233  
4800 Oak Grove Drive  
Pasadena, CA 91109-8099  
(818) 354-2240*

*E-mail: iaoffice@jpl.nasa.gov*

*Refer to NPO-44007, volume and number of this NASA Tech Briefs issue, and the page number.*

## Electrically Variable or Programmable Nonvolatile Capacitors

Capacitances are measured using small AC signals or changed using larger pulses.

Marshall Space Flight Center, Alabama

Electrically variable or programmable capacitors based on the unique properties of thin perovskite films are undergoing development. These capacitors show promise of overcoming two important deficiencies of prior electrically programmable capacitors:

- Unlike in the case of varactors, it is not necessary to supply power continuously to make these capacitors retain their capacitance values. Hence, these capacitors may prove useful as components of nonvolatile analog and digital electronic memories.
- Unlike in the case of ferroelectric capacitors, it is possible to measure the capacitance values of these capacitors without changing the values. In other words, whereas readout of ferroelectric capacitors is destructive, readout of these capacitors can be nondestructive.

A capacitor of this type is a simple two-terminal device. It includes a thin film of a suitable perovskite as the dielectric layer, sandwiched between two metal or metal oxide electrodes (for example, see Figure 1). The utility of this device as a variable capacitor is based on a phenomenon, known as electrical-pulse-induced capacitance (EPIC), that is observed in thin perovskite films and especially in those thin perovskite films that exhibit the colossal magnetoresistive (CMR) ef-

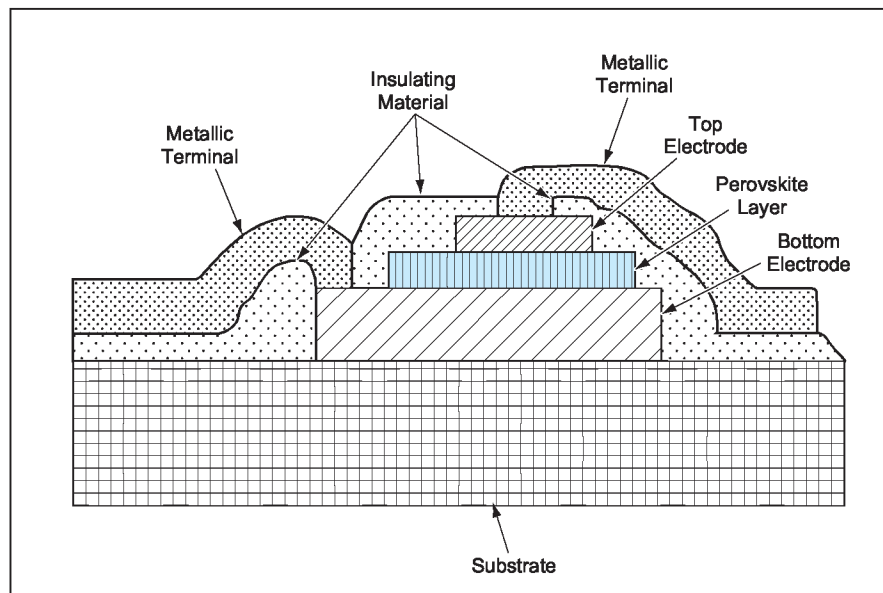

Figure 1. An Electrically Variable Capacitor of the type described in the text can be fabricated on a silicon or other substrate as part of an integrated circuit.

fect. In EPIC, the application of one or more electrical pulses that exceed a threshold magnitude (typically somewhat less than 1 V) gives rise to a nonvolatile change in capacitance. The change in capacitance depends on the magnitude duration, polarity, and number of pulses. It is not necessary to apply a magnetic field or to cool the device

below (or heat it above) room temperature to obtain EPIC. Examples of suitable CMR perovskites include  $Pr_{1-x}Ca_xMnO_3$ ,  $La_{1-x}Ca_xMnO_3$ ,  $La_{1-x}Sr_xMnO_3$ , and  $Nb_{1-x}Ca_xMnO_3$ .

Figure 2 is a block diagram showing an EPIC capacitor connected to a circuit that can vary the capacitance, measure the capacitance, and/or measure the re-

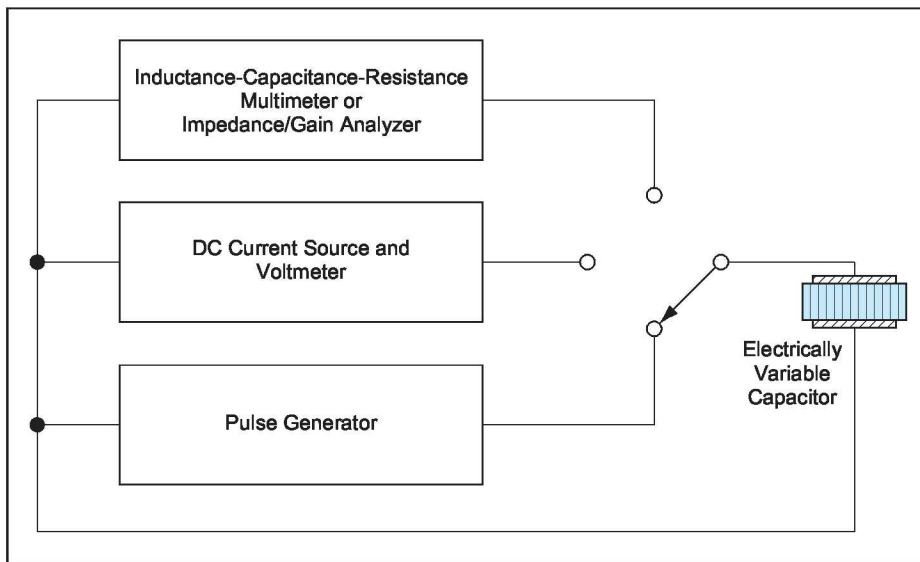

Figure 2. The Capacitance of the Electrically Variable Capacitor is changed or measured, depending on the position of the switch and the nature of the applied signal.

sistance of the capacitor. A pulse generator applies voltage pulses to change the capacitance. If desired, after each pulse, the capacitance and resistance can be measured by use of an inductance-capacitance-resistance multimeter or an impedance/gain analyzer. Also if desired, the DC resistance can be measured by applying a current of  $\approx 1 \mu\text{A}$  and measur-

ing the resulting voltage drop between the electrodes by use of a high-internal-resistance voltmeter. The magnitude of the AC test potential applied by the multimeter or analyzer and/or the magnitude of the DC test potential is kept below 50 mV — well below the threshold magnitude — so as not to change the capacitance unintentionally.

The threshold potential depends on a number of factors, including the composition and thickness of the perovskite film and the details of the process used to fabricate the device. The change in capacitance caused by a given pulse can be wholly or partly reversed by reversing the polarity of the pulse: that is, a pulse with one polarity causes the capacitance to decrease, and a pulse of the opposite polarity causes the capacitance to increase. The sign of the change in capacitance in relation to polarity of a pulse depends on the aforementioned factors and on additional factors, including the capacitance-change history of the device, the amplitude and duration of the pulse. After each change, the capacitance value is stable: It remains the same after repeated measurements using a signal much smaller than a capacitance-changing pulse.

*This work was done by Shangqing Liu, Naijuan Wu, Alex Ignatiev, and Jianren Li of the University of Houston for Marshall Space Flight Center. For more information, contact Sammy Nabors, MSFC Commercialization Assistance Lead, at sammy.a.nabors@nasa.gov. Refer to MFS-31960-1*

## System for Automated Calibration of Vector Modulators

**This test system helps create tabular or algorithmic functions to compensate for non-ideal behavior in vector modulators.**

*NASA's Jet Propulsion Laboratory, Pasadena, California*

Vector modulators are used to impose baseband modulation on RF signals, but non-ideal behavior limits the overall performance. The non-ideal behavior of the vector modulator is compensated using data collected with the use of an automated test system driven by a LabVIEW® program that systematically applies thousands of control-signal values to the device under test and collects RF measurement data.

The technology innovation automates several steps in the process. First, an automated test system, using computer-controlled digital-to-analog converters (DACs) and a computer-controlled vector network analyzer (VNA) systematically can apply different I and Q signals (which represent the complex number by which the RF signal is multiplied) to the vector modulator under test (VMUT), while measuring the RF per-

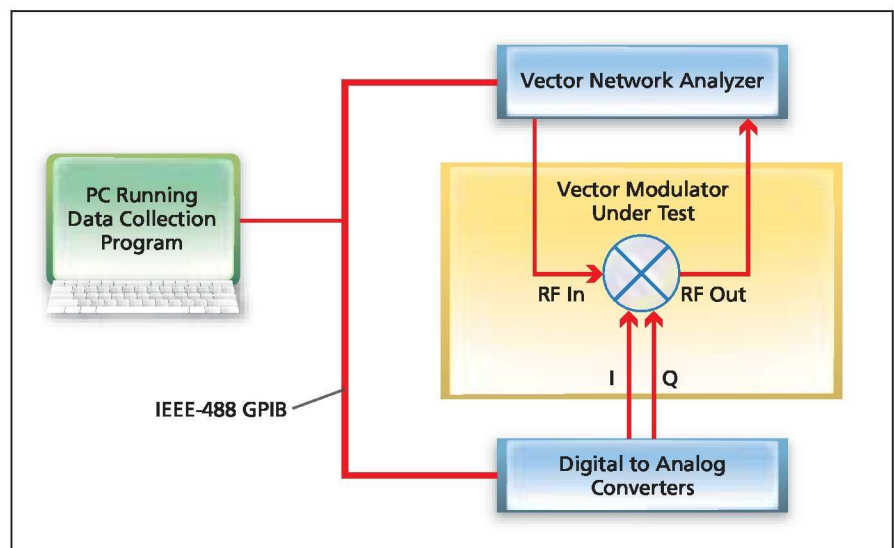

The Automated Test System uses computer-controlled digital-to-analog converters and a VNA to systematically apply I and Q signals to the VMUT, while measuring the RF performance.