

National Aeronautics and Space Administration

The Establishment of a New Friction Stir Welding Process Development Facility at NASA/MSFC

Robert W. Carter
NASA/MSFC EM30
August 2009

Journey to the Moon



What is NASA's Mission?

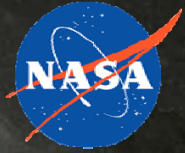

- ◆ Safely fly the Space Shuttle until 2010
- ◆ Complete the International Space Station (ISS)
- ◆ Develop and fly the Orion Crew Exploration Vehicle (CEV)
 - Designed for exploration but will initially service ISS
- ◆ Land on the Moon no later than 2020

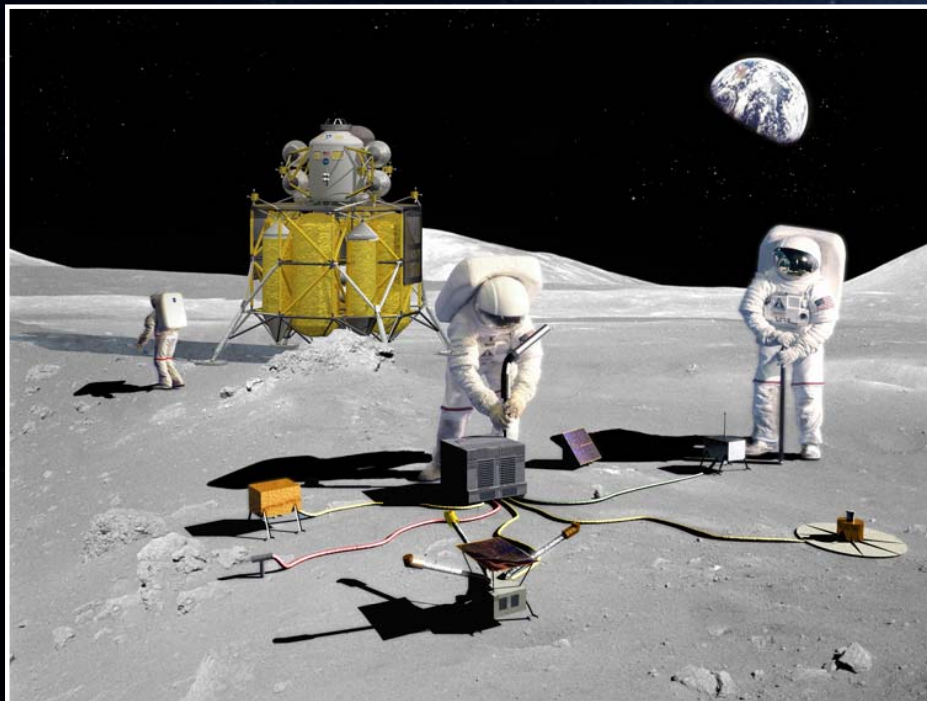

“The next steps in returning to the Moon and moving onward to Mars, the near-Earth asteroids, and beyond, are crucial in deciding the course of future space exploration. We must understand that these steps are incremental, cumulative, and incredibly powerful in their ultimate effect.”

*- Former NASA Administrator
Michael Griffin
October 24, 2006*

Building on a Foundation of Proven Technologies

- Launch Vehicle Comparisons -

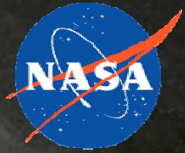

mT - metric tons
 TLI - Trans-Lunar Injection
 LEO - Low Earth Orbit

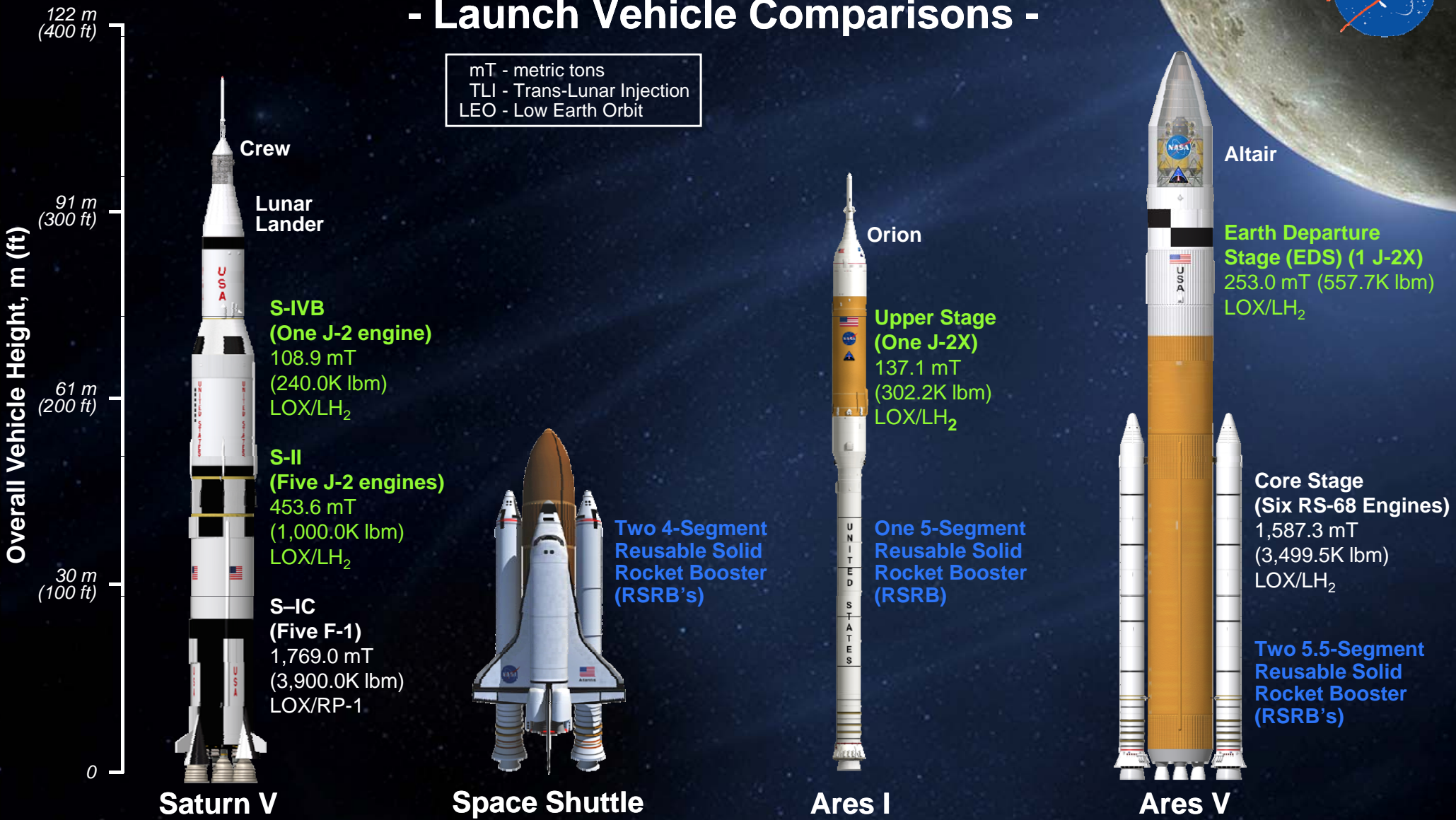

Saturn V

1967–1972

Height: 110.9 m (364.0 ft)
Gross Liftoff Mass :
 2,948.4 mT (6,500K lbm)
Payload Capability:
 44.9 mT (99.0K lbm) to TLI
 118.8 mT (262.0K lbm) to LEO

Space Shuttle

1981–Present

Height: 56.1 m (184.2 ft)
Gross Liftoff Mass:
 2,041.1 mT (4,500.0K lbm)
Payload Capability:
 25.0 mT (55.1K lbm)
 to Low Earth Orbit (LEO)

Ares I

First Flight 2015

Height: 99.1 m (325.0 ft)
Gross Liftoff Mass :
 927.1 mT (2,044.0K lbm)
Payload Capability:
 25.5 mT (56.2K lbm)
 to LEO

Ares V

First Flight 2018

Height: 116.2 m (381.1 ft)
Gross Liftoff Mass :
 3,704.5 mT (8,167.1K lbm)
Payload Capability:
 71.1 mT (156.7K lbm) to TLI (with Ares I)
 62.8 mT (138.5K lbm) to TLI
 ~187.7 mT (413.8K lbm) to LEO

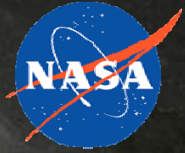

Ares I Elements

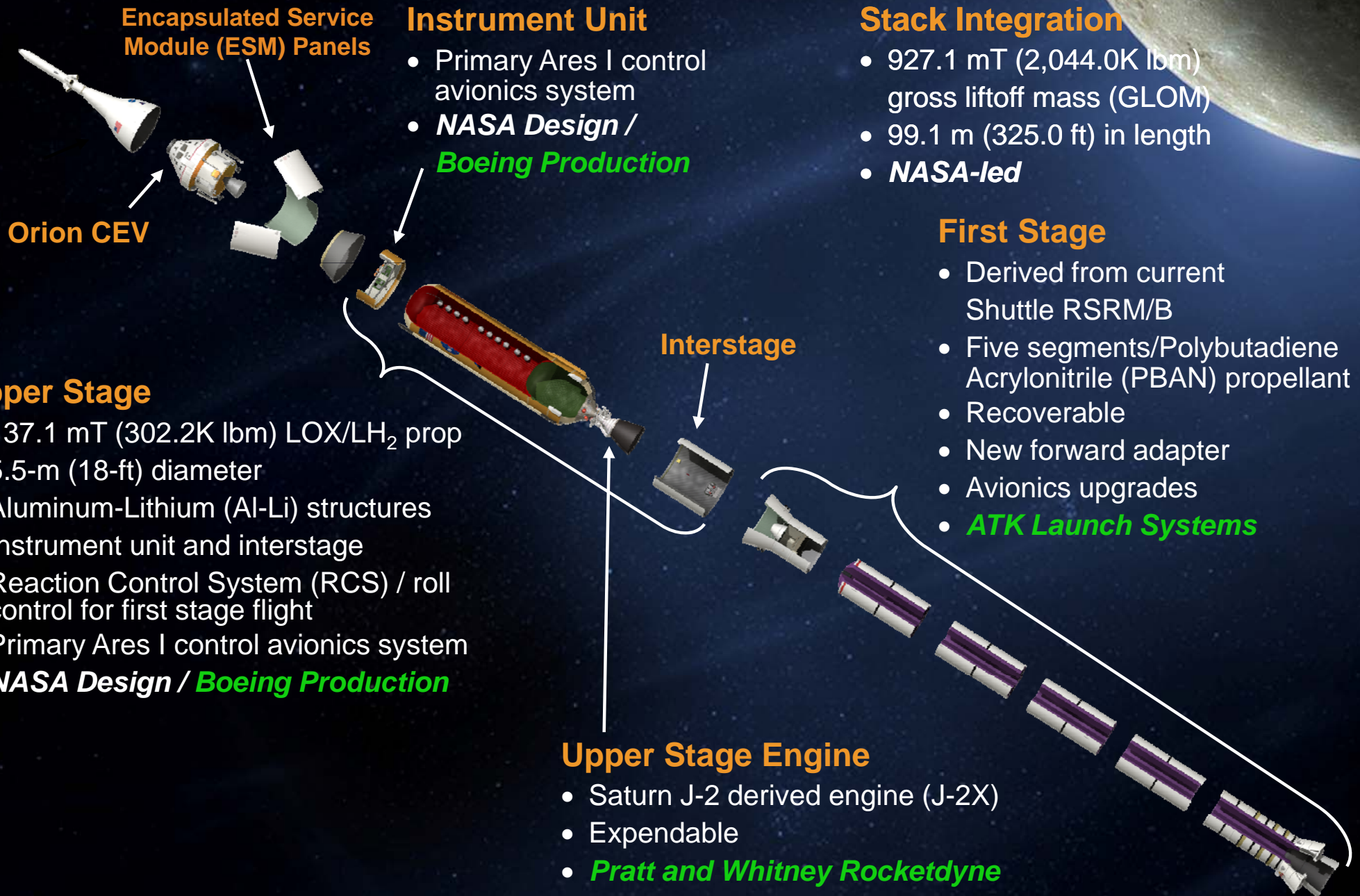

Encapsulated Service Module (ESM) Panels

Instrument Unit

- Primary Ares I control avionics system
- **NASA Design / Boeing Production**

Stack Integration

- 927.1 mT (2,044.0K lbm) gross liftoff mass (GLOM)
- 99.1 m (325.0 ft) in length
- **NASA-led**

Orion CEV

Upper Stage

- 137.1 mT (302.2K lbm) LOX/LH₂ prop
- 5.5-m (18-ft) diameter
- Aluminum-Lithium (Al-Li) structures
- Instrument unit and interstage
- Reaction Control System (RCS) / roll control for first stage flight
- Primary Ares I control avionics system
- **NASA Design / Boeing Production**

Interstage

First Stage

- Derived from current Shuttle RSRM/B
- Five segments/Polybutadiene Acrylonitrile (PBAN) propellant
- Recoverable
- New forward adapter
- Avionics upgrades
- **ATK Launch Systems**

Upper Stage Engine

- Saturn J-2 derived engine (J-2X)
- Expendable
- **Pratt and Whitney Rocketdyne**

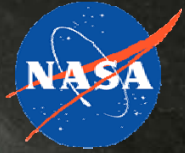

Ares V Elements



Altair Lunar Lander

Stack Integration

- 3,704.5 mT (8,167.1K lbm) gross liftoff mass
- 116.2 m (381.1 ft) in length

Solid Rocket Boosters

- Two recoverable 5.5-segment PBAN-fueled boosters (derived from current Ares I first stage)

Payload Fairing

Earth Departure Stage (EDS)

- One Saturn-derived J-2X LOX/LH₂ engine (expendable)
- 10-m (33-ft) diameter stage
- Aluminum-Lithium (Al-Li) tanks
- Composite structures, instrument unit and interstage
- Primary Ares V avionics system

Loiter Skirt

Core Stage

- Six Delta IV-derived RS-68 LOX/LH₂ engines (expendable)
- 10-m (33-ft) diameter stage
- Composite structures
- Aluminum-Lithium (Al-Li) tanks

RS-68

Ares I Design and Development at MSFC

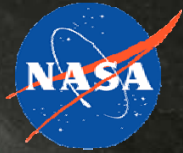

- ◆ Currently the Ares I Upper Stage is being designed and developed at the Marshall Space Flight Center (MSFC).
- ◆ Production of the Upper Stage will occur at the NASA Michoud Assembly Facility (MAF) in New Orleans.
- ◆ At MSFC Friction Stir Welding equipment capable of assembling full-scale Ares I hardware is being installed in the Advanced Weld Development Facility at Building 4755.

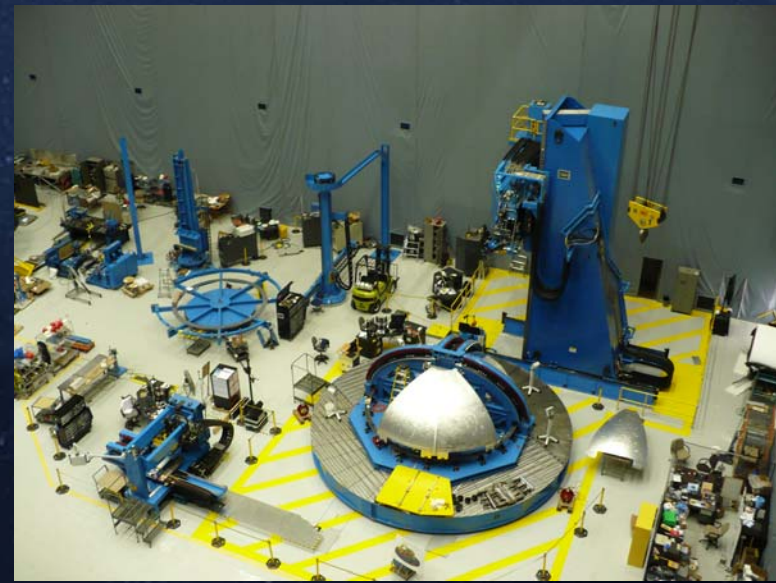

Images show the weld process development facility

Full Scale Welding Process Development



- ◆ The tools and equipment being installed in the laboratory will be used to assemble full-scale manufacturing demonstration and development articles.
- ◆ Full-Scale development allows engineers to trouble-shoot issues that will inevitably arise during the development of large scale hardware.
- ◆ Only at full scale can the true challenges associated with production be identified and dealt with.



Hardware Delivery

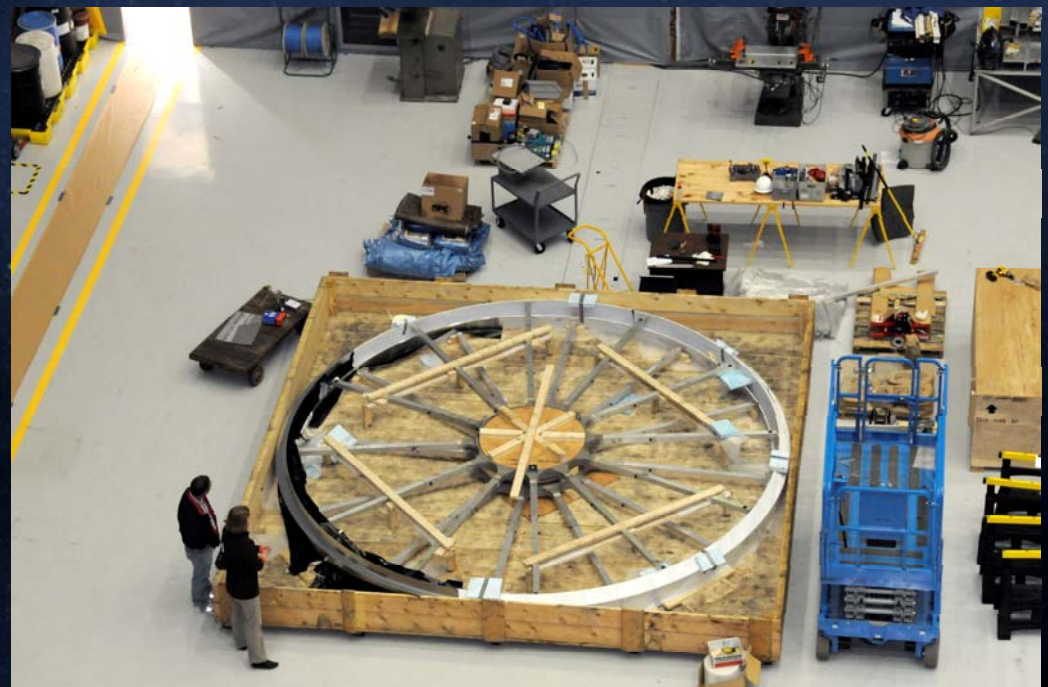

18-Foot Diameter 1-piece Y-Ring

The Manufacturing Demonstration Article

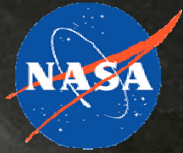

- ◆ The Manufacturing Demonstration Article (MDA) emulates the forward end of the Upper Stage liquid Hydrogen tank
- ◆ The MDA has two primary objectives.
 - First, to perform a full-scale manufacturing demonstration of all major components required to assemble Ares I Upper Stage tanks.
 - Second, perform full-scale demonstration of all major welded assembly steps required for Ares I upper stage tanks.
- ◆ All components are AA2195

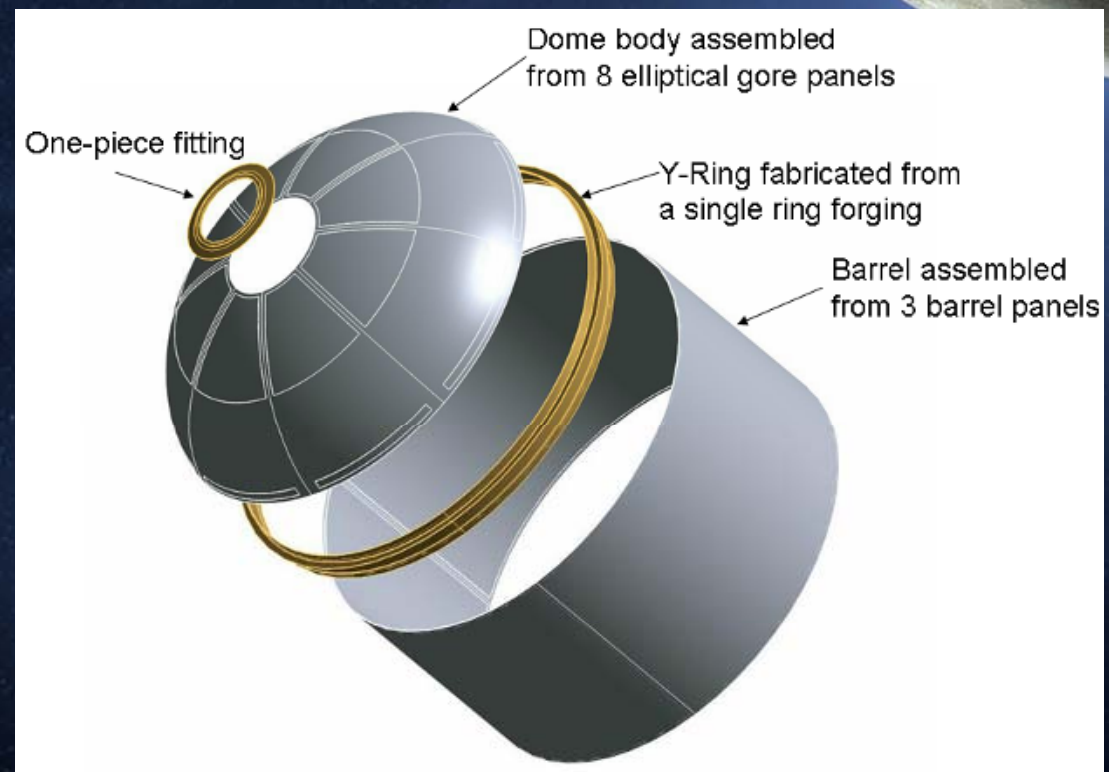

Exploded View of the MDA

Manufacturing Demonstration Article Weld Map

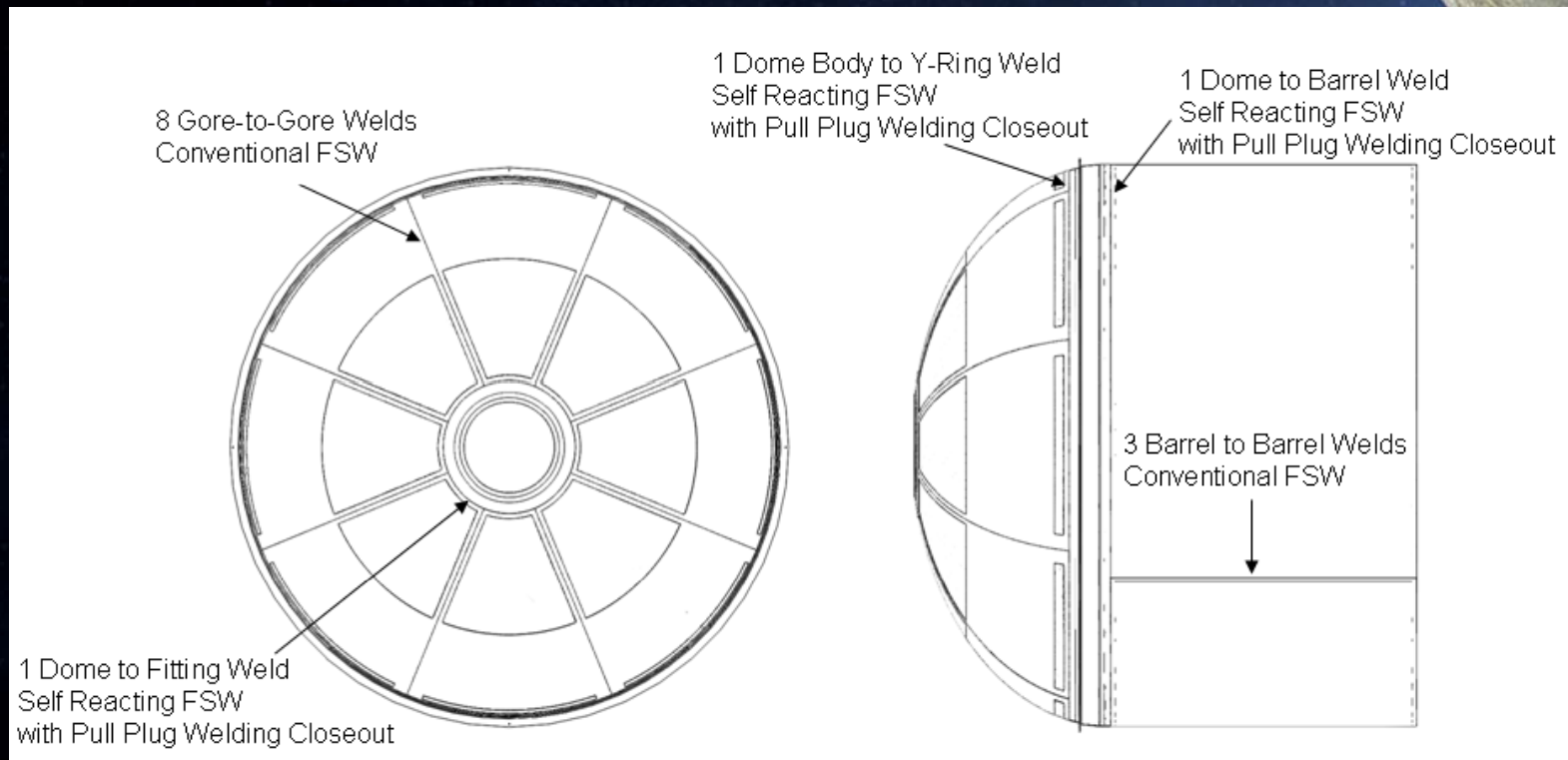

MDA Weld Map

- ◆ **The MDA has 4 different weld joint configurations and requires three welding processes to assemble.**
 - Self Reacting FSW will be used for the circular y-ring and fitting welds
 - Conventional FSW will be used for all barrel and gore welds

Tools and Equipment Required for MDA Assembly



RWT



VWT

- ◆ **The Robotic Weld Tool (RWT)**
 - 7-axis robot capable of performing both Self Reacting and Conventional FSW on complex curvature tank structures up to Ares V size
- ◆ **Fixtures for the Robotic Weld Tool**
 - Used to hold and position components on the RWT turntable.
- ◆ **Process Development System (PDS)**
 - Used for panel-level development.
- ◆ **The Morton Table Tool (MTT)**
 - Used to close-out Self Reacting Friction Stir Welds using Friction Pull Plug Welding.
 - Also used to perform fusion seal weld on Common Bulkhead assembly.
- ◆ **The Vertical Weld Tool (VWT)**
 - Designed to accommodate assembly of barrel sections up to Ares V size
- ◆ **Vertical Trim Tool (VTT)**
 - Necessary to trim completed tank barrel sections to length.

The Robotic Weld Tool

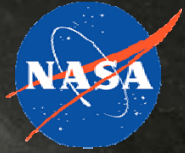

- ◆ Supplied by MTS Systems Corporation.
- ◆ 7-axis machine tool capable of making both conventional and self-reacting friction stir welds in complex (e.g. not linear) weld joints.
- ◆ 3-axis horizontal traveling column with retractable boom
- ◆ 2-axis roll and pitch assembly positioned on the end of the boom
- ◆ Rotary turntable that can both slew and slide.

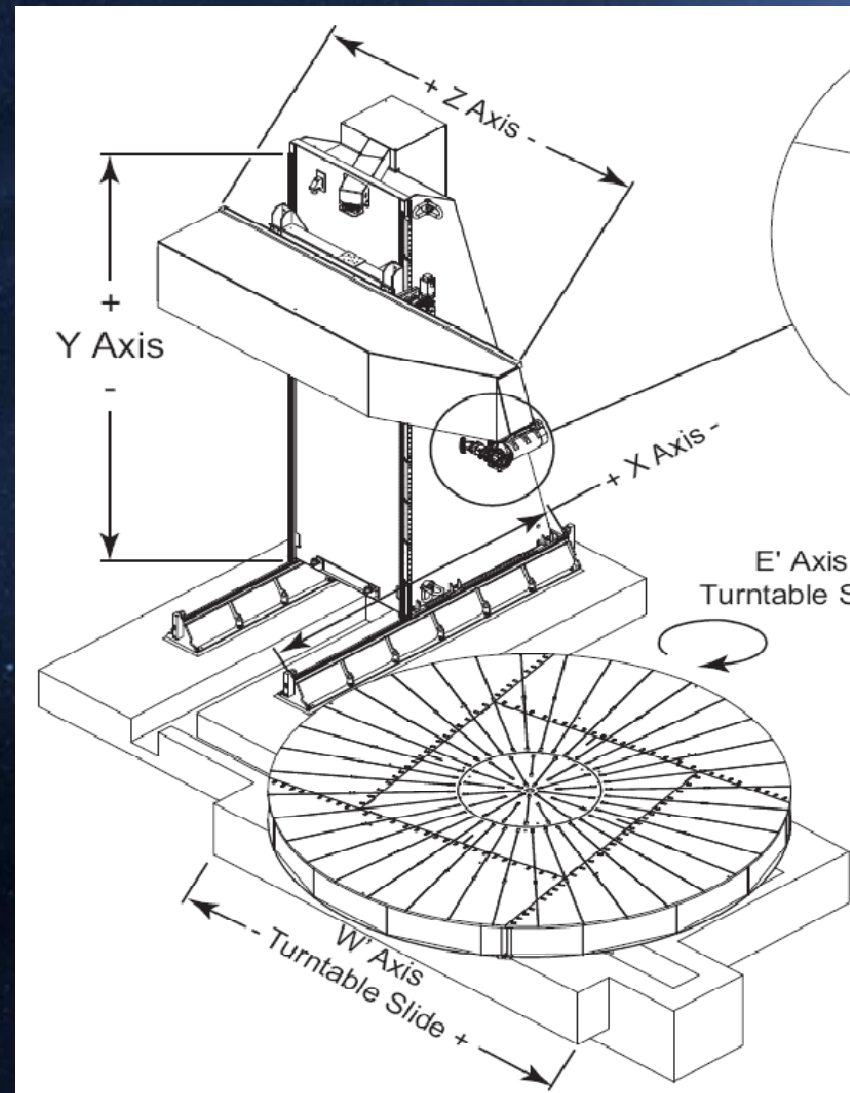

Robotic Weld Tool Fixtures



- ◆ **All Manufacturing Demonstration Article dome welding operations will take place on the RWT**
- ◆ **Three welding fixtures are required;**
 - Gore Welding Fixture
 - Y-ring Welding Fixture
 - Fitting Welding Fixture
- ◆ **All fixtures were designed and manufactured in-house at NASA/MSFC.**

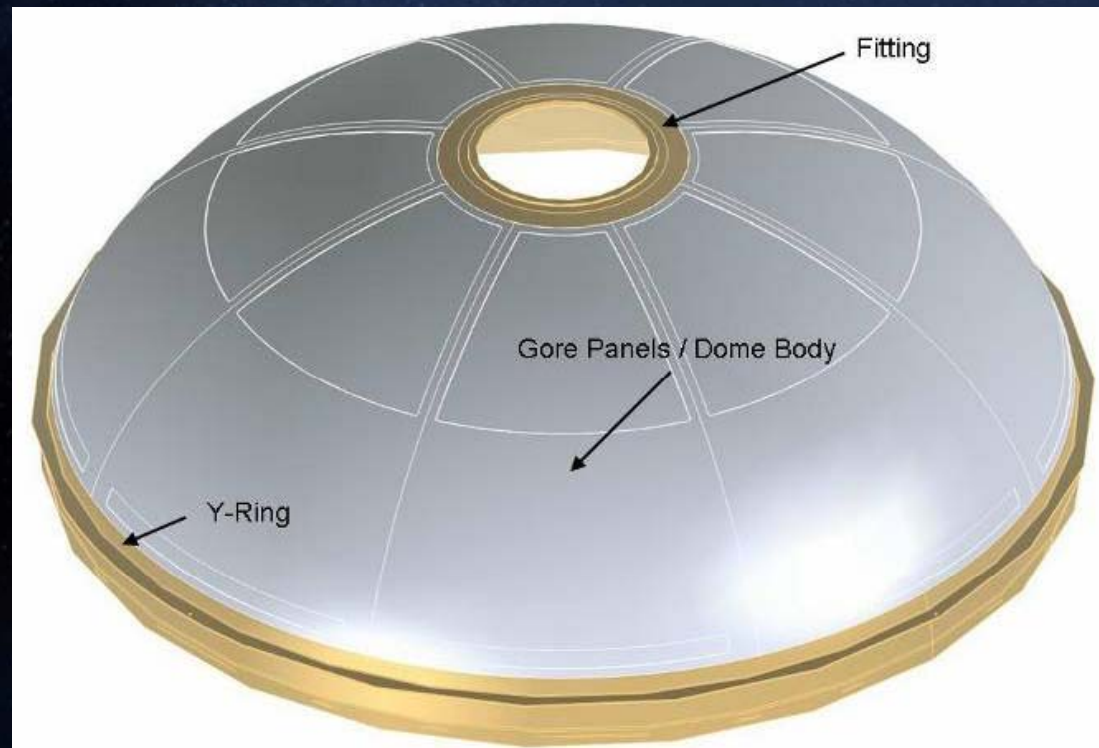

Key RWT Fixture Requirements

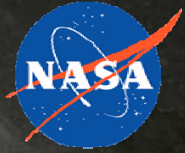

- ◆ **The MDA dome welding fixtures must support:**
 - Trimming operations
 - Partial-penetration tack welding
 - Full-penetration welding using either Conventional or Self Reacting
 - Phased Array Ultrasonic (PAUT) inspection using the RWT weld head to manipulate the transducer wedge



Left: First weld on gore fixture
Above: Y-Ring welding fixture being assembled (5/4/09)

Gore Welding Fixture



- ◆ All gore-to-gore welds are performed using conventional FSW
- ◆ Single welding position, and two 180° opposed trim positions.
- ◆ All positions are equipped with an internal support mandrel, external clamping beams, and pneumatic clamp assemblies

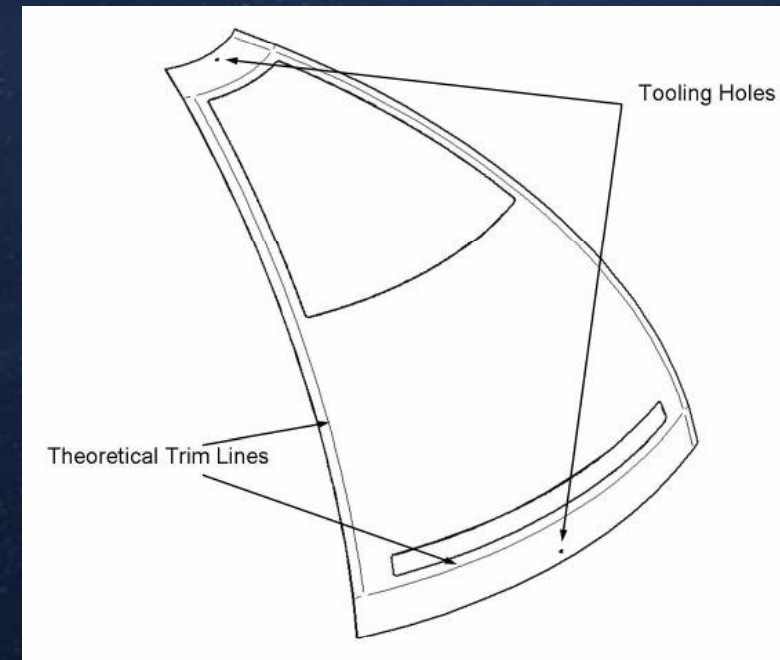
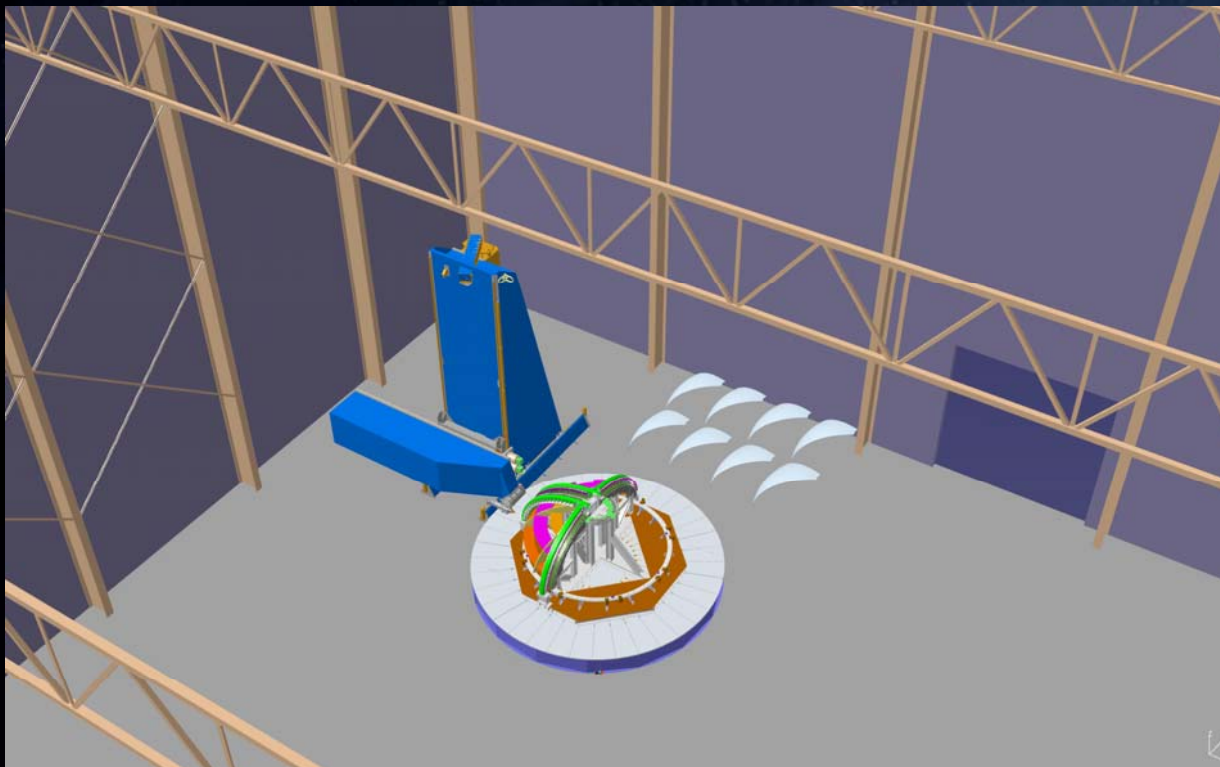

MDA Gore Panel

γ-Ring Welding Fixture

- ◆ Used for SR-FSW of Y-Ring to dome body.
- ◆ Two internal mandrels, one located on each side of the joint .
- ◆ Two external clamping rings, one located on each side of the joint.
- ◆ Designed to allow the y-ring to be moved up and down relative to, and coaxial with, the dome body.
 - **Allows the weld joint to be separated for trimming and pre-weld preparation, and then mated for welding.**

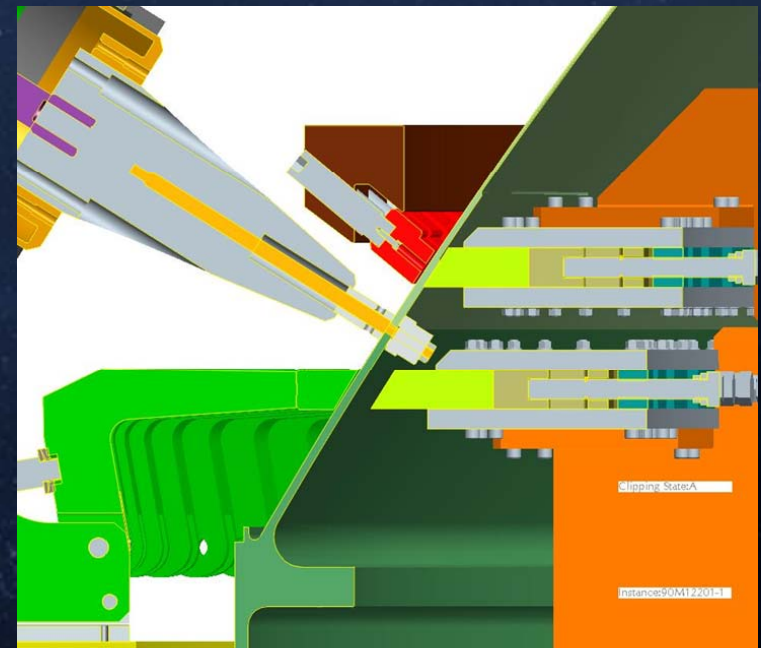
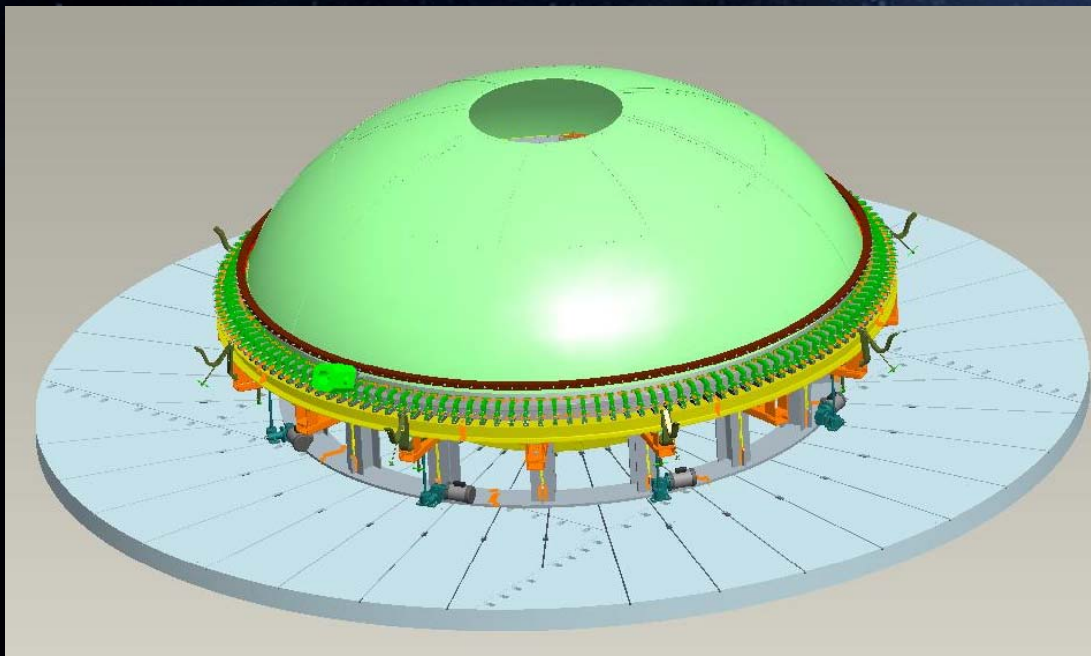

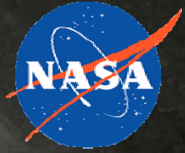

Fitting Welding Fixture

- ◆ Used for SR-FSW of Y-Ring to dome body.
- ◆ Includes two internal mandrel structures; one to support the dome body side of the joint, and another to support the fitting side of the joint.
- ◆ A support pedestal enables the fitting to be raised and lowered via a jacking system.
 - This allows the weld joint to be separated for trimming and pre-weld preparation operations, and then mated for welding.
- ◆ The fixture includes two sets of external clamps that are supported by a gantry that spans over the top of the dome.

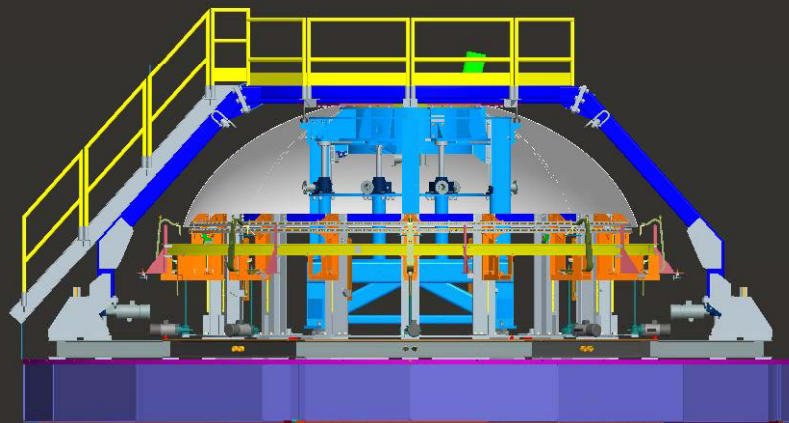

X.X +0.1
X.XX +0.03
X.XXX +0.010
ANG. +0.5

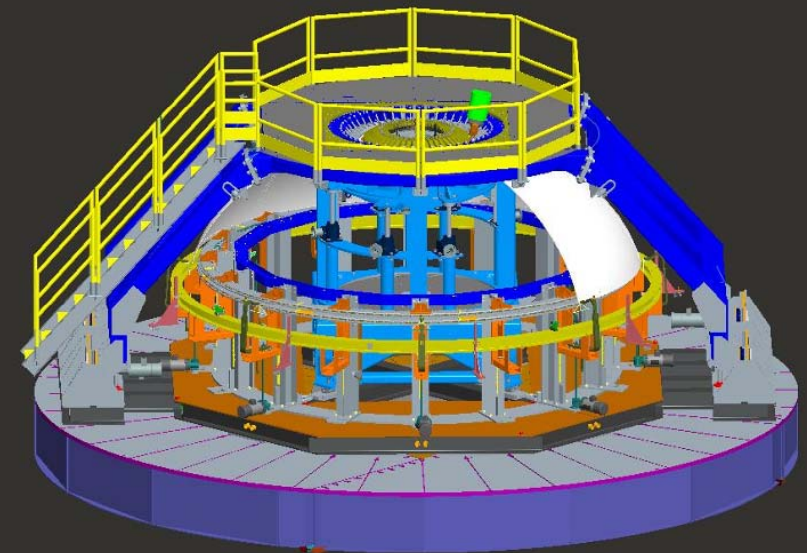

X.X +0.1
X.XX +0.03
X.XXX +0.010
ANG. +0.5

Process Development System (PDS)



- ◆ **Supplied by MTS Systems as an option on the RWT contract.**
 - The PDS provides a critical spare parts inventory for the RWT
- ◆ **Work horse of the facility – used for panel-level process development.**
- ◆ **“Standard” PDS unit with high torque option.**
- ◆ **Pumps are co-located with the RWT pumps and a common chiller is used for both the RWT and PDS.**



Morton Table Tool (MTT)

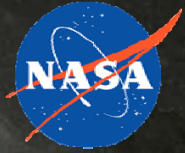

- ◆ Multi-purpose station for performing friction pull plug welds and gas tungsten arc welds on Ares I upper stage gores, domes, and barrels.
- ◆ Will perform plug welding close-out in circular and circumferential Self Reacting welds.
- ◆ Also will be used to perform a GTA seal weld on the Common Bulkhead.

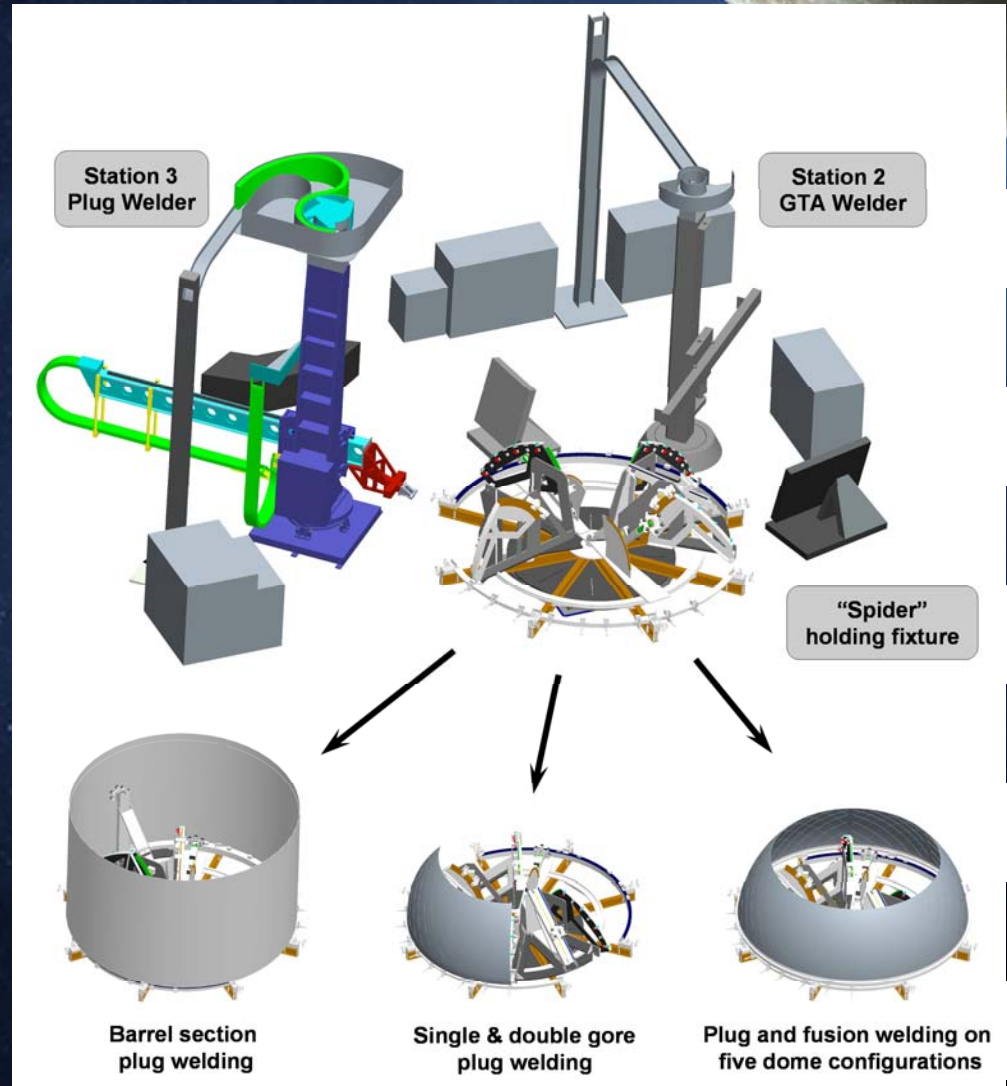

Vertical Weld Tool (VWT)

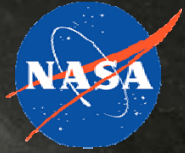

- ◆ Mechanical systems provided by Transformation Technologies Inc. (now Manufacturing Technologies Inc.)
- ◆ Control system and integration by Lockheed Martin Huntsville Technical Operations.
- ◆ Designed to assemble full-scale cylindrical barrel sections.
 - **Can accommodate barrels up to Ares V size.**
- ◆ Capability of both conventional and self reacting FSW.



Vertical Weld Tool

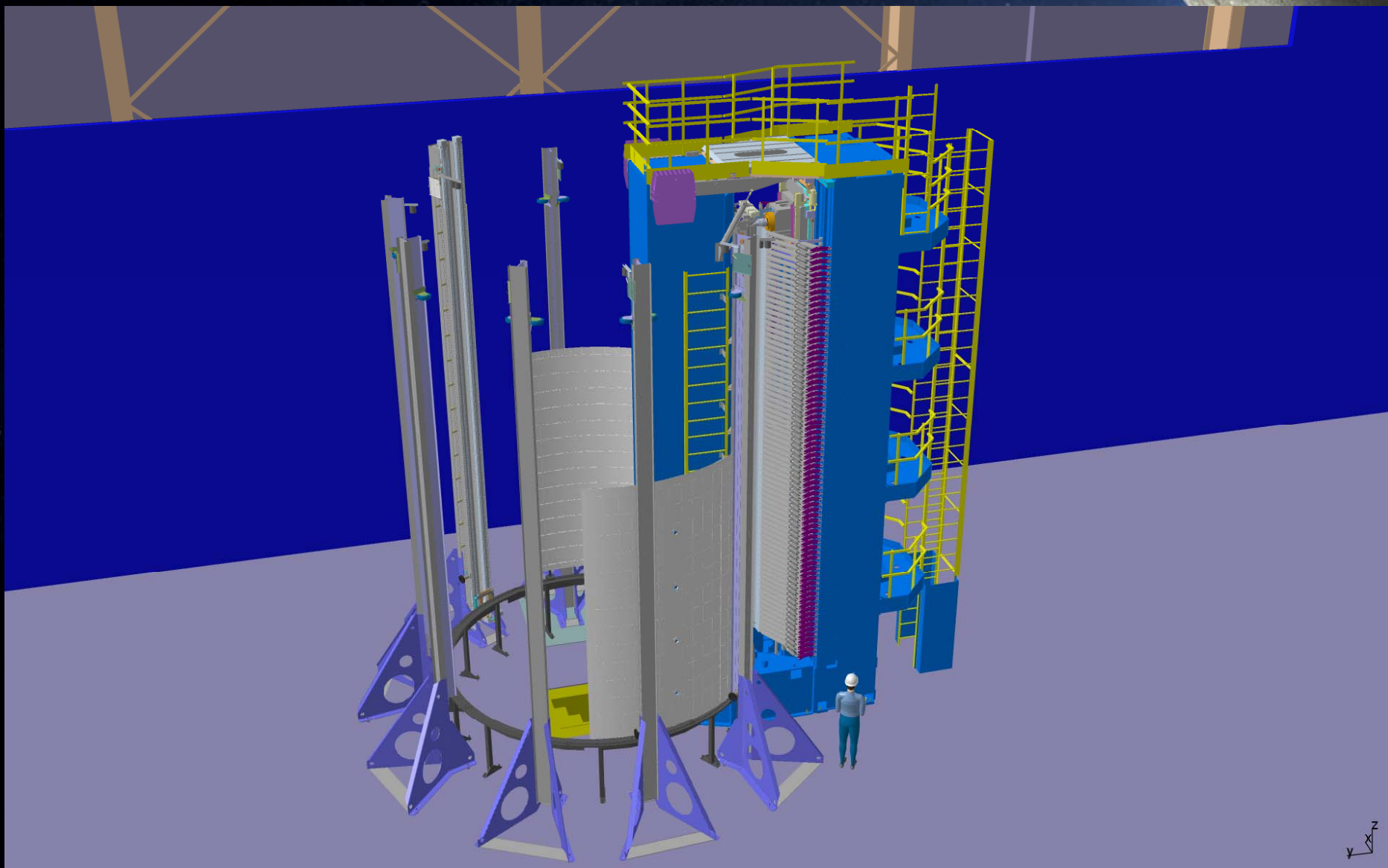
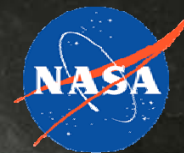

VWT Clamping System

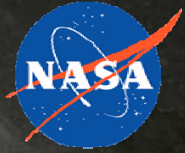

- ◆ 148 pneumatically actuated clamps.
- ◆ Each clamp uses a 3 inch long clamp foot.

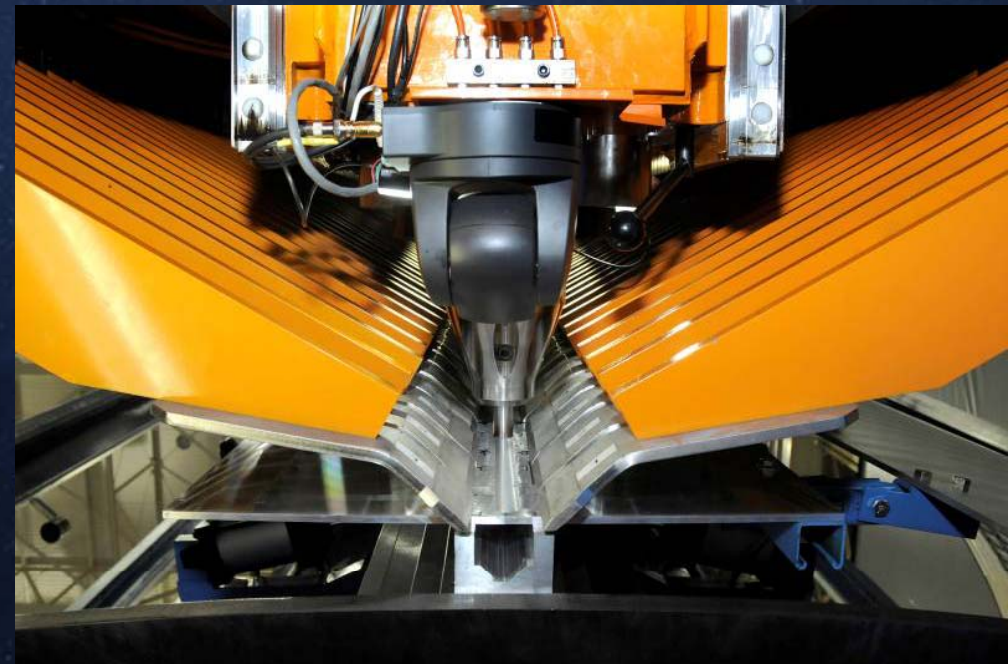

VWT Anvil System



- ◆ Anvil is a four-sided beam
- ◆ Each of the four sides has provisions for a unique tool surface
- ◆ The anvil can be indexed
- ◆ Anvil positions are:
 - Flat – used for conventional FSW in flat panels
 - Curved – has a 9-foot radius machined on the surface and is used for conventional FSW in barrel panels
 - Trim – has a groove that allows for trimming operations and also allows SR-FSW
 - Stepped Trim – this anvil also has a groove, but the two sides of the groove are offset to allow two barrel panels to overlap. This overlap is necessary when making the final trim in a barrel section.

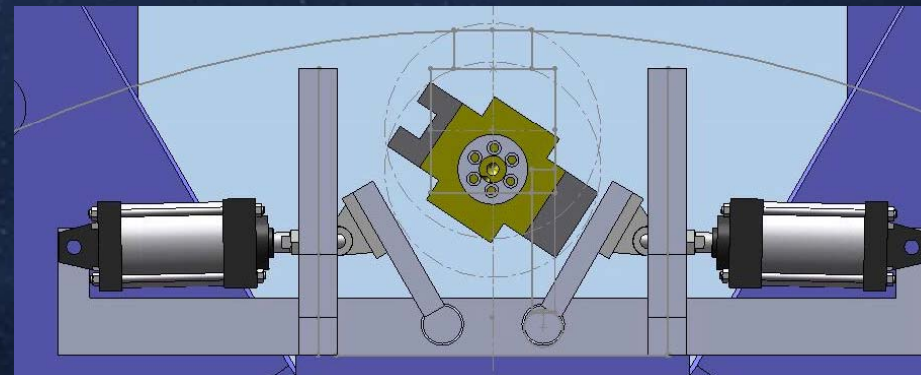
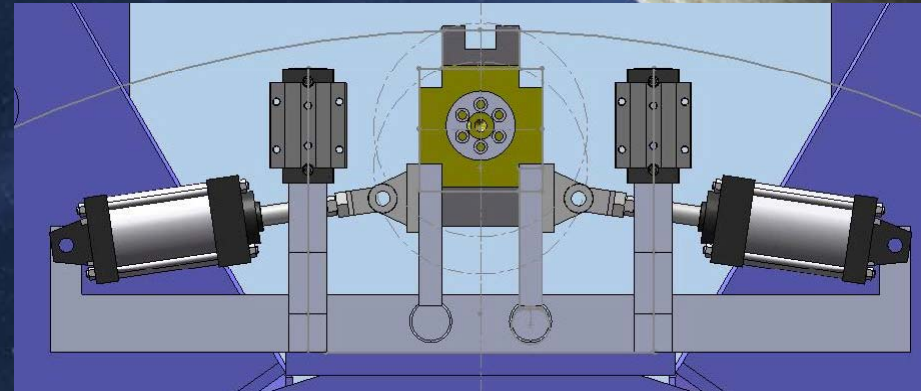

VWT Gate Assembly



- ◆ To prevent the two towers from separating, and also to allow finished barrels to be removed from the tool, a pneumatically actuated gate assembly is installed on top of the VWT.
- ◆ The gate ties together the top of the Vertical Weld Tool to prevent weld and clamping forces from separating the anvil and carriage towers.

Image taken during carriage tower installation shows the gate in its open position.

Summary



- ◆ Full-scale weld process development is being performed at MSFC to develop the tools, fixtures, and facilities necessary for Ares I production.
- ◆ Full scale development in-house at MSFC fosters technical acuity within the NASA engineering community, and allows engineers to identify and correct tooling and equipment shortcomings before they become problems on the production floor.
- ◆ Finally, while the new weld process development facility is currently being outfitted in support of Ares I development, it has been established to support all future Constellation Program needs. In particular, both the RWT and VWT were sized with the larger Ares V hardware in mind.



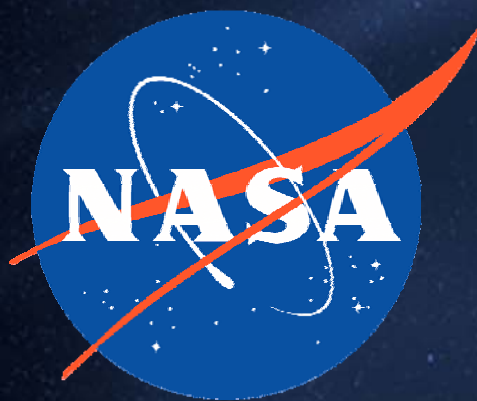

www.nasa.gov/ares