

# Testing to Characterize the Advanced Stirling Radioisotope Generator Engineering Unit

Edward J. Lewandowski<sup>1</sup> and Jeffrey G. Schreiber<sup>2</sup>  
*NASA Glenn Research Center, Cleveland, OH, 44135*

**The Advanced Stirling Radioisotope Generator (ASRG), a high efficiency generator, is being considered for space missions. Lockheed Martin designed and fabricated an engineering unit (EU), the ASRG EU, under contract to the Department of Energy. This unit is currently undergoing extended operation testing at the NASA Glenn Research Center to generate performance data and validate life and reliability predictions for the generator and the Stirling convertors. It has also undergone performance tests to characterize generator operation while varying control parameters and system inputs. This paper summarizes and explains test results in the context of designing operating strategies for the generator during a space mission and notes expected differences between the EU performance and future generators.**

## I. Introduction

**T**HE Advanced Stirling Radioisotope Generator (ASRG) continues flight development towards potential use on space missions. A key step in this process was the design and fabrication of an ASRG engineering unit (EU), by system integrator Lockheed Martin Space Systems Company (LM) under contract to the Department of Energy.<sup>1</sup> The generator assembly was completed in December 2007 and controller integration followed in March 2008. This unit underwent a series of system-level tests to qualification level thermal and dynamic environments at LM. These included thermal balance, thermal performance, mechanical disturbance, sine transient, random vibration, simulated pyrotechnic shock, and electromagnetic interference.<sup>2</sup> Following an internal inspection, LM delivered the ASRG EU to the NASA Glenn Research Center (GRC) on August 28, 2008, for extended operation. The EU underwent inspection followed by integration into a test facility specially designed for it. The ASRG EU began extended operation on November 6, 2008. This test is intended to demonstrate extended operation of an integrated system and to provide additional data from long-term operation of Stirling convertors. The EU has operated over 11,000 hours to date at NASA GRC.

The ASRG EU is the first Stirling generator system tested at GRC that has an integrated heat source, insulation, sealed housing, and controller. Figure 1 shows a cutaway model of the ASRG EU. The EU contains two Advanced Stirling Convertors (ASC-Es) secured together with an interconnect sleeve. An electric heat source (EHS), held against each ASC-E heat collector, provides the heat input. The cold-side adapter flanges (CSAFs) conduct heat rejected from the convertors through the beryllium housing and fins for radiation in a vacuum environment or convection to air. Argon fills the housing, sealed using o-rings and gaskets. A gas management valve allows access to the argon. A pressure relief device (PRD) is provided to vent the argon during launch as the surrounding air pressure approaches the vacuum of space, improving effectiveness of the insulation surrounding the heat source. The controller is mounted to the outside of the housing. Connectors on the end enclosures, housing, and controller provide electrical interfaces to the alternators, sensors, power input and output, control, and telemetry. The EU is secured via four mounting tabs on one end of the housing either to a spacecraft interface or directly to its support.

The Stirling convertors in the ASRG are primarily controlled by modulating the piston amplitude. The heat input from the General Purpose Heat Source (GPHS) module cannot be regulated as the radioisotope slowly decays over time. The rejection temperatures reach equilibrium in response to the amount of heat being rejected, the space environment, proximity and orientation with respect to the Sun, and other passively-determined factors. From testing to fueling, launch, and mission, the piston amplitude will be adjusted to maintain hot-end temperature in an acceptable range, optimize system performance, and take into account other considerations. Since the ASRG system does not use piston amplitude sensing for control and instead controls alternator voltage, enough margin needs to be

---

<sup>1</sup> Electrical Engineer, Thermal Energy Conversion Branch, 21000 Brookpark Rd, AIAA Member.

<sup>2</sup> Stirling Team Lead, Thermal Energy Conversion Branch, 21000 Brookpark Rd, AIAA Senior Member.

provided to keep piston amplitude in an acceptable range. This paper quantifies the effects of certain control parameters and system inputs on generator operation that play into defining the control strategies and provides insight into some of the control strategies that may be used during the mission. Conducting these tests on the generator level instead of the convertor level is important because convertor-generator thermal interactions contribute to generator performance, and because the control strategies need to consider the generator as a system and not just a collection of components.

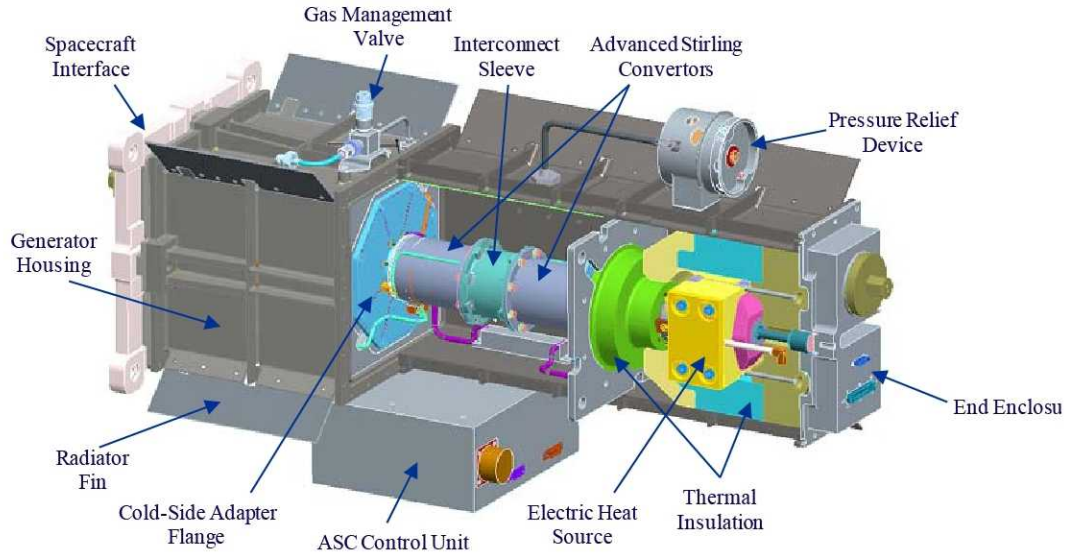

**Figure 1. ASRG EU cutaway model.**

## II. Test Set-up

The ASRG EU was tested in a facility designed and fabricated at NASA GRC specifically for the ASRG EU, shown in Fig. 2.<sup>3</sup> The ASRG EU is mounted on a test table through stand-offs and is surrounded by a Lexan cage. Ductwork, fans, heat exchangers, and plumbing to a circulator (not shown) for cooling all reside underneath the table. The test rack, which contains the power supplies, the instrumentation, the computer, and the data acquisition, control, and monitoring system, is placed to the left of the test table. An argon cylinder and associated gas management hardware sit behind the test table. Framed Lexan partitions surround the test facility.

This test facility has the features and capabilities necessary to conduct the desired performance tests. They include:

- Providing heat input of up to 400 W into each ASC convertor.
- Providing two input power options for the heat source control: (1) fixed hot-end temperature mode, which was used for initial extended-operation convertor tests, and (2) fixed heat input mode, which simulates the GPHS module characteristics and tests the temperature-control feature of the ASC Controller Unit (ACU).
- Removing heat from the EU fins and housing in a way that maintains a fairly constant rejection temperature at the convertor cold end, at set points between 60 and 100 °C.
- Providing two convertor control options: (1) alternating-current (AC) bus control, and (2) ACU control.
- The ability to vary DC bus voltage when under ACU control.

Data were gathered using a LabVIEW data system. Most parameters were sampled at 2,000 Hz and averaged over one second. The averaged data, called two-second data, was saved every 2



**Figure 2. ASRG EU test facility.**



seconds, meaning every other second's worth of data was recorded. For more representative steady-state data, further averaging was done by averaging the 2-second data over 5 minutes, creating the 5-minute average data.

The tests were conducted with an AC bus controller rather than the engineering-level ACU. A number of changes are being made between the engineering-level ACU, known as Engineering Development Unit (EDU) 1, and the flight controller. The EDU 1 ACU contains algorithms early in the design process not representative of the flight design. Using EDU 1 ACU would have affected some of the test results, making it difficult to separate the effects of parameter variation from the influence of controller algorithms. Consequently, the convertors were controlled using the AC bus controller for these tests.

A simplified schematic of the AC bus control system is shown in Fig. 3. An AC bus grid is created by connecting the output of an AC power supply across resistors through a 9.75:1 transformer. The AC bus voltage was varied by changing the voltage set point of the AC power supply. The alternators are connected in parallel to the AC bus grid with tuning capacitors, which compensate for the alternator inductance and bring the power factor near unity. In this configuration the two convertors are not controlled independently; setting the one AC bus voltage determines both convertors' amplitudes.

The baseline conditions for this test were recorded with fixed heat input (about 264.1 W for ASC A and 274.9 W for ASC B) and fixed AC bus voltage (7.71 V).

The tests conducted include the following:

- Effect of AC bus voltage (and thus piston amplitude) variation
- Effect of heat input variation, including the effect of decreased piston amplitude at reduced heat input
- Effect of cold-end temperature and pressure vessel temperature variation.

In addition, convertor start-up and shutdown characteristics were studied.

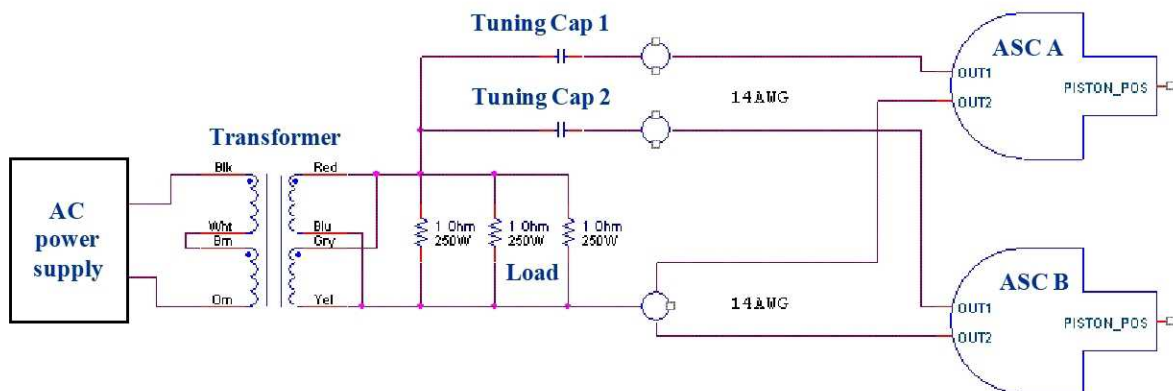

Figure 3. AC bus control system schematic.

### III. Test Results

#### A. Effect of AC Bus Voltage Variation

The AC bus voltage variation test adjusted the AC bus voltage in several steps while observing the change in hot-end temperatures, with other settings held constant. The AC bus voltage directly controls the piston amplitudes. Increasing AC bus voltage results in increased piston amplitudes and increased heat moved through the Stirling cycle. With heat input to the cycle fixed, hot-end temperatures decrease. This test characterizes the sensitivity of hot-end temperature to changes in piston amplitude.

Three AC bus voltage step sizes were tested: two steps up which result in an initial 0.05 mm increase in piston amplitude from the baseline, and one 0.05 mm step down. The AC bus voltage variation test results are summarized in Table I. ASC A and ASC B sensitivities are very similar and range from 0.23 to 0.30 mm/V for piston amplitude and from  $-73$  to  $-81$  °C/V for hot-end temperature.

ASRG EU performance is very repeatable under AC bus control. When the system was returned to baseline conditions, piston amplitudes were within 0.007 mm and hot-end temperatures were within 0.4 °C.

**Table I. AC bus voltage variation test results summary.**

	AC bus (Vrms)	Amplitude (mm)		Temperature (°C)	
		ASC A	ASC B	ASC A	ASC B
Baseline	7.71	4.240	4.251	627	625.3
First 0.05 mm initial amplitude increase	7.84	4.279	4.29	617	615.4
Change in V, mm, or °C	0.13	0.039	0.039	-10.0	-9.9
Sensitivity, $\Delta/V$		0.300	0.300	-76.9	-76.2
Second 0.10 mm amplitude initial increase	7.98	4.31	4.322	606.6	605.5
Change in V, mm, or °C	0.27	0.070	0.071	-20.4	-19.8
Sensitivity, $\Delta/V$		0.259	0.263	-75.6	-73.3
0.05 mm initial amplitude decrease	7.59	4.209	4.223	636.7	634.8
Change in V, mm, or °C	-0.12	-0.031	-0.028	9.7	9.5
Sensitivity, $\Delta/V$		0.258	0.233	-80.8	-79.2
Baseline (repeated after test)	7.71	4.239	4.258	627.1	625.7

Figure 4 shows the transient response of the generator to a step change in AC bus voltage for the first two steps. The piston amplitudes immediately changed with the change in AC bus voltage, but then fell back from the peak amplitude. The amplitude changed in response to hot-end temperature changes which affect internal pressure and the engine’s power capability. A similar phenomenon occurs during start-up and shutdown: with fixed AC bus voltage, piston amplitude increases with increasing hot-end temperature and vice versa.

**B. Effect of Heat Input Variation**

Over the 17-year design life of the ASRG, the heat output of a nominal 250-W GPHS module will decrease by 12.6% or about 31.4 W. To simulate the effect of this change, the heat input to each convertor was decreased 5, 10,

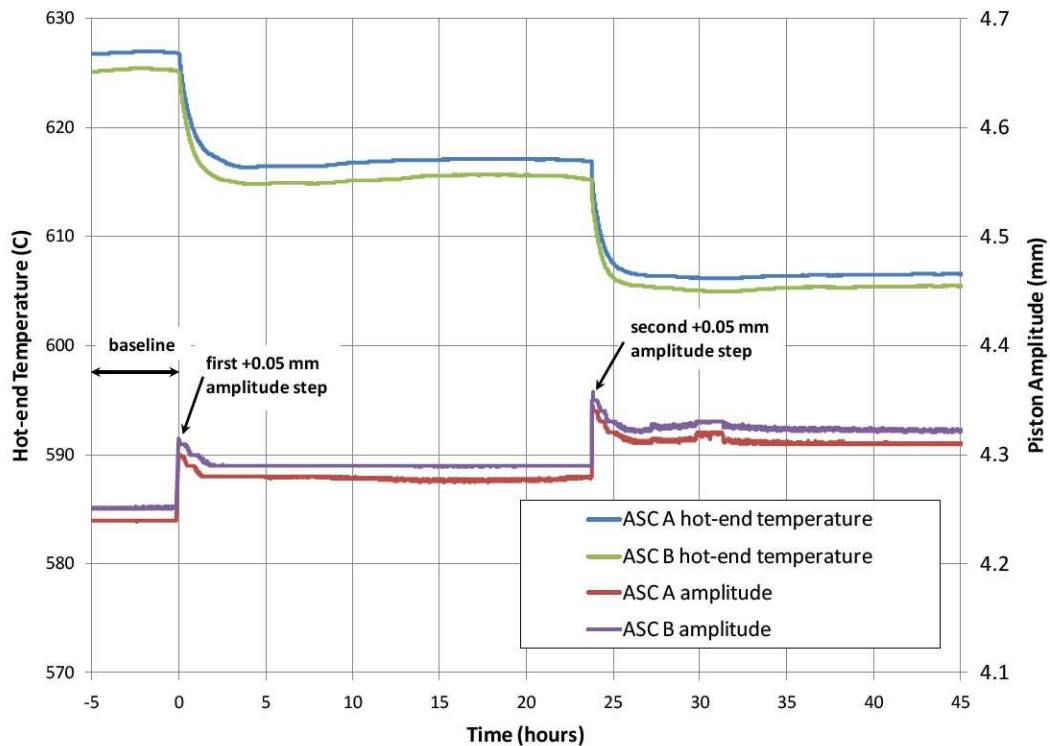

**Figure 4. Effect of AC bus voltage variation on hot-end temperature and piston amplitude with heat input constant.**



20, and 30 W from the baseline values. In addition, heat input was increased by 5 W to generate additional test data. One approach to operating the generator as heat input decreases involves decreasing the piston amplitude in order to maintain a higher hot-end temperature, thereby improve conversion efficiency and increase output power. To validate this approach, while the EU was operating at the lowest heat input level, the piston amplitudes were decreased in three steps to increase hot-end temperatures back to the original values.

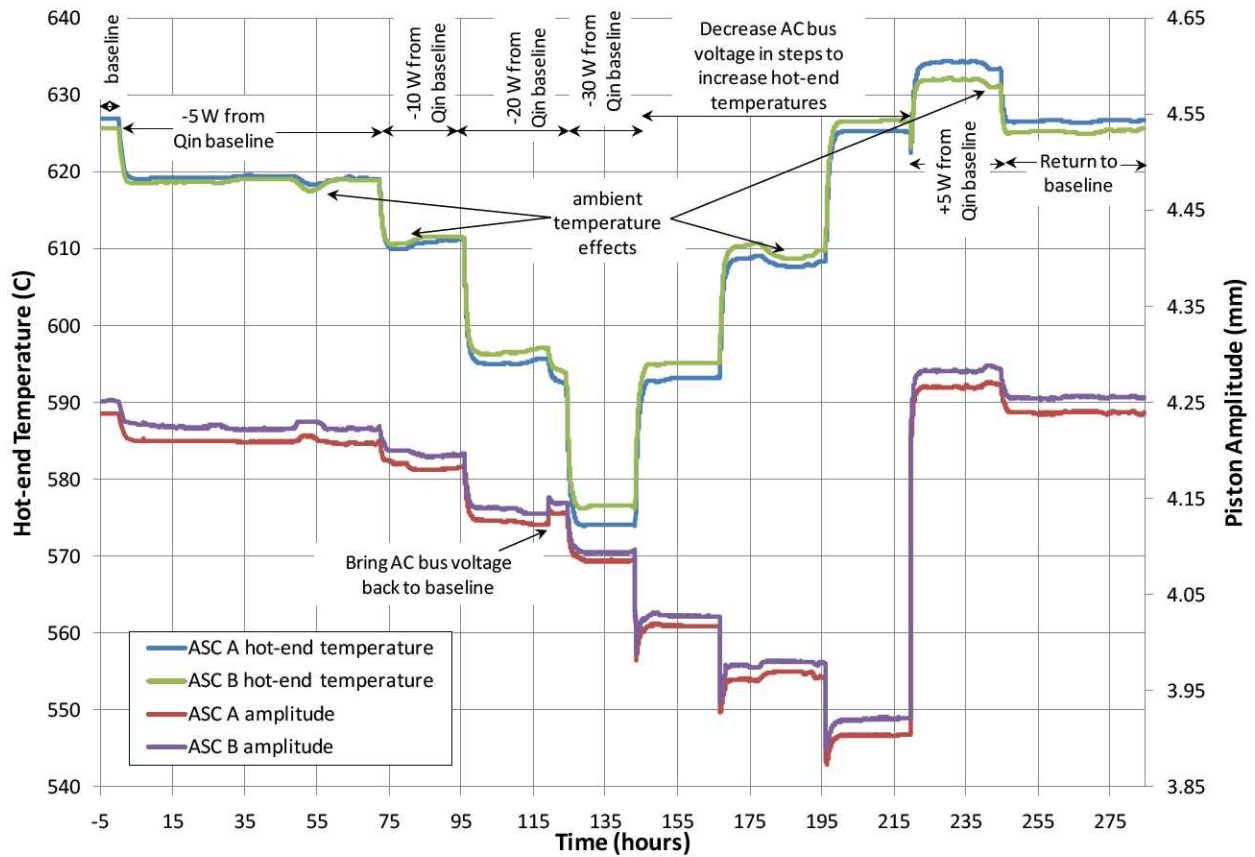

**Figure 5. Transient effect of heat input variation and AC bus voltage variation on hot-end temperature and piston amplitude.**

Figure 5 shows the transient effect of heat input variation and AC bus voltage variation on hot-end temperature and piston amplitude. The responses of ASC A and ASC B are very similar in magnitude. At the  $-20$  W step it was observed that the AC bus voltage had decreased from the baseline value of 7.71 Vrms to 7.67 Vrms due to voltage drops caused by small impedances in the test rack wiring. To bring the AC bus voltage back to the baseline value, the AC power supply voltage was increased.

In Fig. 5 one can observe small rises in piston amplitudes and corresponding small dips in hot-end temperatures around 51, 77, 187, and 242 hours. These result from small increases in the rejection and pressure vessel temperatures due to a rise in ambient temperature. Ambient temperature changes affect the heat rejection temperatures on the generator. This is because the Lexan cage around the EU is not insulated and is not perfectly sealed, allowing some interchange of ambient air with the air inside the cage.

Figure 6 plots the steady-state results of the heat input variation test and shows the decrease in hot-end temperatures with decreasing heat input over the range of  $+5$  to  $-30$  W deviation from nominal heat input. The slope of the line, or the sensitivity, appears slightly lower at higher hot-end temperatures. The data show that the sensitivity varies by between 1.12 and 1.76  $^{\circ}\text{C}/\text{W}$ , with sensitivity decreasing with hot-end temperature (Fig. 7). ASC A sensitivities are slightly higher.

Piston amplitude also changes with varying heat input, decreasing with decreasing heat input (Fig. 6). This phenomenon helps reduce the drop in hot-end temperature with lower heat input, since decreasing piston amplitude itself tends to increase hot-end temperature.

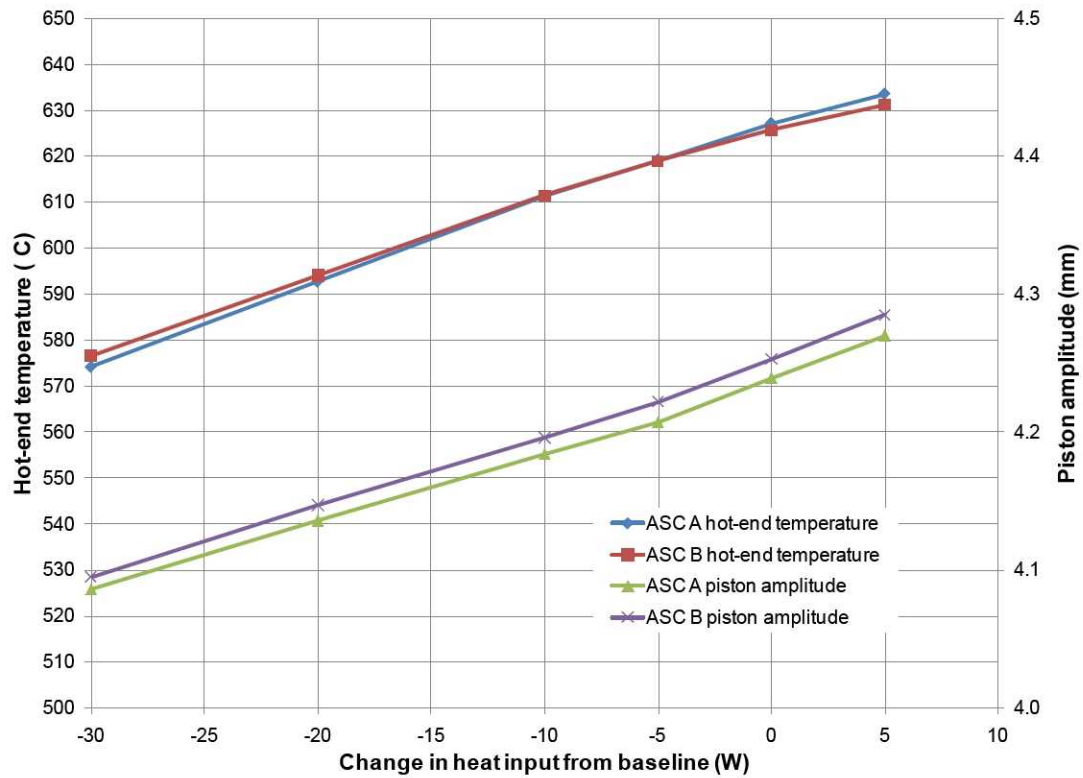

Figure 6. Effect of heat input variation on hot-end temperature and piston amplitude.

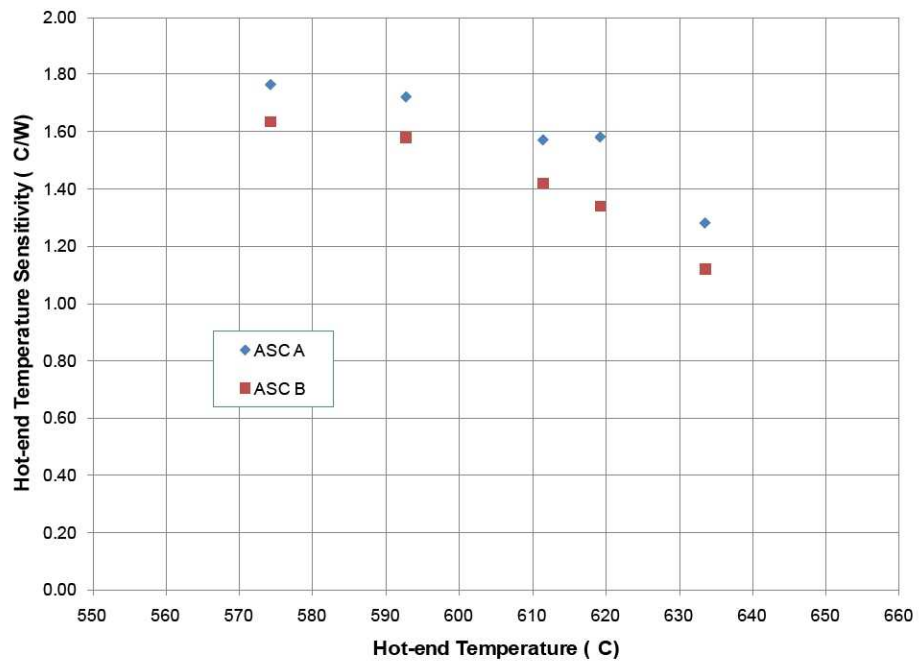

Figure 7. Sensitivity of hot-end temperature to heat input variation as a function of hot-end temperature.



### 1. Decreasing piston amplitude to increase hot-end temperature

When the ASRG operates in flight, the controller may decrease the convertor piston amplitudes as the radioisotope heat source decays in order to increase system efficiency by maintaining higher hot-end temperatures. This control scenario was simulated during this test. When heat input to each convertor was reduced by 30 W, the piston amplitudes were decreased to bring the hot-end temperatures back up to about 625 °C. The ASC A piston amplitude was decreased by 0.31 mm, and the ASC B piston amplitude by 0.32 mm. This was accomplished by decreasing the AC bus voltage by 1.08 Vrms to 6.63 Vrms and took place in four AC bus voltage steps as shown in Fig. 5.

Figure 8 shows alternator power as a function of hot-end temperature, with constant heat input. The alternator power increased with increasing hot-end temperature up to a point, with the peak power occurring in the hot-end temperature range of 590 to 610 °C. On a system level, the peak power does not necessarily occur at the maximum hot-end temperature. While Stirling convertor thermodynamic efficiency increases with hot-end temperature, other losses such as insulation heat loss and heater head conduction losses also increase.

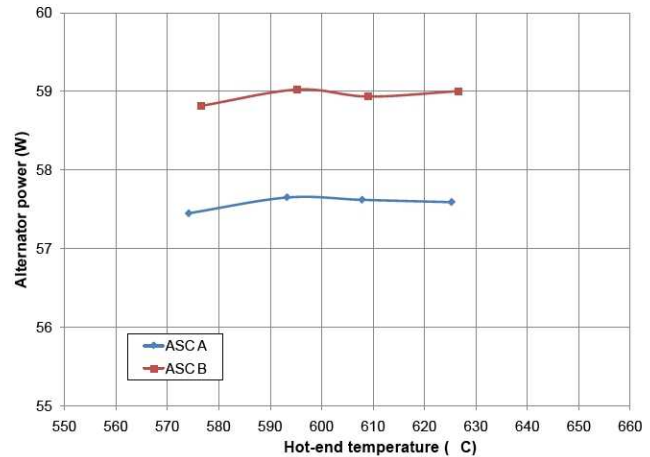

**Figure 8. Effect of hot-end temperature on alternator power with constant heat input.**

### C. Effect of Cold-End Temperature and Pressure Vessel Temperature Variation

The ASRG rejects low-temperature heat through the fins and surfaces of the generator. The surface temperatures are expected to vary during the course of the mission due to a number of factors mentioned previously in the introduction. The generator surface temperatures determine the Stirling convertor cold-end temperatures and pressure vessel temperatures. For this test the surface temperature of the ASRG EU housing was adjusted to vary cold-end temperatures and pressure vessel temperatures.

Data were taken at three operating points, with 24 hours allowed between each point to reach steady-state: the nominal extended operation test point, a reduced pressure vessel temperature test point, and a high pressure vessel temperature test point. Temperatures were first reduced from baseline values by reducing the temperature of the fluid cooling the air around the ASRG EU from 10 to 5 °C. Then temperatures were increased by increasing the fluid temperature to 32 °C and turning off the auxiliary fans used to enhance heat transfer at the surface of the generator.<sup>3</sup>

The test results are summarized in Table II and shown graphically in Fig. 9. Increasing pressure vessel temperature caused an increase in mean pressure. Piston amplitude and alternator voltage increased while hot-end temperature, output power, and efficiency decreased with increasing pressure vessel temperature.

The ASC B pressure vessel temperature was lower than the ASC A because the ‘B’ end of the generator is cooled by air directly from the heat exchangers, while the ‘A’ end is cooled by air already heated from the ‘B’ end.

Increasing pressure vessel temperature caused a small increase in alternator voltage and piston amplitude. Increasing the pressure vessel temperature directly increases the mean pressure of the working fluid in the convertors, shifting the natural frequency of the convertor higher. Since the AC bus controller maintains a fixed operating frequency, the alternator terminal voltage increases to achieve the necessary total spring for that frequency. Other smaller effects of increased pressure vessel temperature include the magnets becoming a little weaker, which would decrease voltage for fixed piston amplitude, and the coil resistance increasing.

The increase in piston amplitude resulted in a decrease in hot-end temperature at higher pressure vessel temperatures. The ASC A hot-end temperature decreased at a rate of  $-0.97$  °C/°C, and the ASC B hot-end temperature decreased at a rate of  $-1.35$  °C/°C.

The combination of increased cold-end temperature and decreased hot-end temperature at higher pressure vessel temperatures resulted in reduced convertor gross efficiency (alternator power output/gross heat input), and as a result the alternator power dropped with increasing pressure vessel temperature at a rate of  $-0.15$  to  $-0.16$  W/°C.

**Table II. Cold-end temperature and pressure vessel (PV) temperature variation test results.**

Test point	PV temp (°C)		Hot-end temp (°C)		Cold-end temp (°C)		Piston amplitude (mm)		Alternator power (W)		Alternator voltage (Vrms)		Convertor gross efficiency	
	ASC A	ASC B	ASC A	ASC B	ASC A	ASC B	ASC A	ASC B	ASC A	ASC B	ASC A	ASC B	ASC A	ASC B
1. Reduced PV temp	63.3	62.8	629.7	629.5	60.0	59.3	4.227	4.244	67.21	68.73	10.252	9.944	25.5%	25.0%
2. Baseline	66.5	66.2	626.3	625.2	63.3	62.7	4.243	4.258	66.91	68.27	10.308	9.974	25.3%	24.8%
3. High PV temp	96.1	91.6	598.0	590.5	94.3	88.7	4.373	4.379	62.36	64.11	10.839	10.209	23.6%	23.3%
<i>Delta from reduced PV temp to high PV temp</i>	32.8	28.8	-31.7	-39	34.3	29.4	0.146	0.135	-4.85	-4.62	0.587	0.265	-1.9%	-1.7%
<i>Sensitivities</i>			-0.97 °C/°C	-1.35 °C/°C			4.45 x 10 <sup>-3</sup> mm/°C	4.69 x 10 <sup>-3</sup> mm/°C	-0.15 W/°C	-0.16 W/°C	0.018 Vrms/°C	0.009 Vrms/°C		
4. High PV temp, reduced AC bus voltage	95.2	90.8	633.2	624.8	93.1	87.7	4.242	4.255	62.88	64.70	11.136	10.605	23.8%	23.5%

A fourth data point was taken at a reduced AC bus voltage of 7.25 V to observe the effect of increasing hot-end temperature at high pressure vessel temperature by reducing piston amplitude back down to the nominal 4.25 mm. The results (shown in Table II) were a 0.2% increase in convertor gross efficiency and 0.52 and 0.59 W increase in alternator power for ASC A and ASC B respectively.

**D. Start-up and Shutdown Characteristics**

Although the convertors will never be shut down while in flight, during ground operation the convertors will start and stop numerous times. The flight convertors will be operated during the convertor and generator build and test process. The generator will be started and fueled, then brought up to full temperature. This section discusses typical convertor start-up with an EHS. Start-up during fueling will be similar in principle but differ because of use of a nuclear heat source of fixed heat output.

The typical ASC start-up procedure consists of applying some heat to the hot end of the convertor to increase hot-end temperature, motoring the convertor, and then adding heat to bring the hot-end temperature to the desired operating point. In the process, piston amplitude needs to be maintained in a suitable range by adjusting AC bus voltage.

The convertors begin operation by motoring the piston, meaning an AC voltage is applied to the alternator to cause the piston to oscillate back and forth. Before beginning motoring, the piston needs to be axially positioned in a suitable location within its range of travel so that it will eventually oscillate about the mean position. When the convertor is operating, a gas center port system maintains the piston center of oscillation near the mean position. But this center port system does not function when the piston is not moving and there are no pressure forces to drive the piston in or out. If the piston is not in a suitable axial position when motoring commences, the piston may never “catch” the center ports and will oscillate at one end of its range rather than about the mean position.

When the convertor is not operating, the ASC’s piston is not constrained to a nominal mean position by mechanical springs or magnetic spring from the alternator. The piston is free to move in (towards the heater head) or out (away from the heater head), and will move due to gravity alone. If the piston begins motoring near the center ports, it will catch the center ports. If the piston begins motoring out from the center ports, it will tend to drift inward

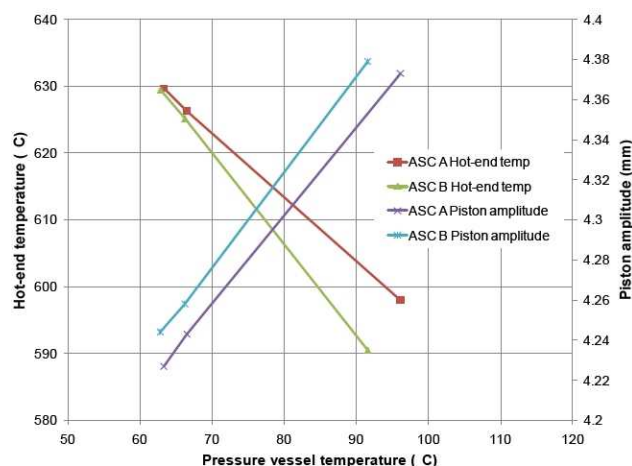

**Figure 9. Effect of pressure vessel temperature on hot-end temperature and piston amplitude with heat input and AC bus voltage constant.**



due to differential leakage across the piston and catch the center ports. But if the piston begins motoring in from the center ports, the piston will continue to move in and eventually oscillate against the displacer.

If the piston is not in a suitable position for starting, a small voltage applied across the terminals pushes the piston to a suitable position. When mounted horizontally, the piston will not drift. If the converter is mounted vertically with the heater head up, the piston will move out past the center ports. It is acceptable to begin motoring the piston in this position because, as mentioned earlier, the piston tends to drift in when oscillating, so the piston eventually catches the center port and then remains centered. This is the case with ASC A in the ASRG EU as oriented as shown in Fig. 2. Centering and starting is most complicated if the converter is mounted vertically with the heater head down. The piston needs to be pushed out (up), then, before the piston can drift past the center ports, the converter needs to begin motoring. This is the case with ASC B in the ASRG EU.

Figure 10 shows a typical start-up using an EHS. The hot-end is warmed up by applying power to the heat source. This reduces the amount of power required to motor the converter.

To avoid the possibility of converter overstroke or run-away without load, the converter is motored before the hot-end temperature gets close to the temperature at which positive power is produced (around 175 °C). The converters are motored by bringing up the AC bus voltage. When motored the converter acts as a cryocooler, pumping heat from the hot end to the cold end as indicated by the dip in hot-end temperature in Fig. 10 just after time = 0.

During motoring the piston amplitude is maintained sufficiently high so that the gas bearings function, to avoid piston-cylinder or rod-piston contact. The voltage required to motor the converters at this amplitude exceeds the voltage required to maintain a higher amplitude at full power. After start-up, the heat input is increased to 380 W, which significantly exceeds the heat output of a GPHS. This reduces the time required to reach full temperature.

As the converter heats up, motoring requires less power, and at the same time piston amplitude begins to increase. The AC bus voltage is decreased to avoid the possibility of piston-displacer contact, as the phase angle at low temperature differences is such that piston and displacer might contact if amplitude is too high. Also, by limiting piston amplitude, the converter reaches full temperature more quickly because less heat is being drawn through the converter's Stirling cycle, and more heat goes into heating the thermal mass at the hot end.

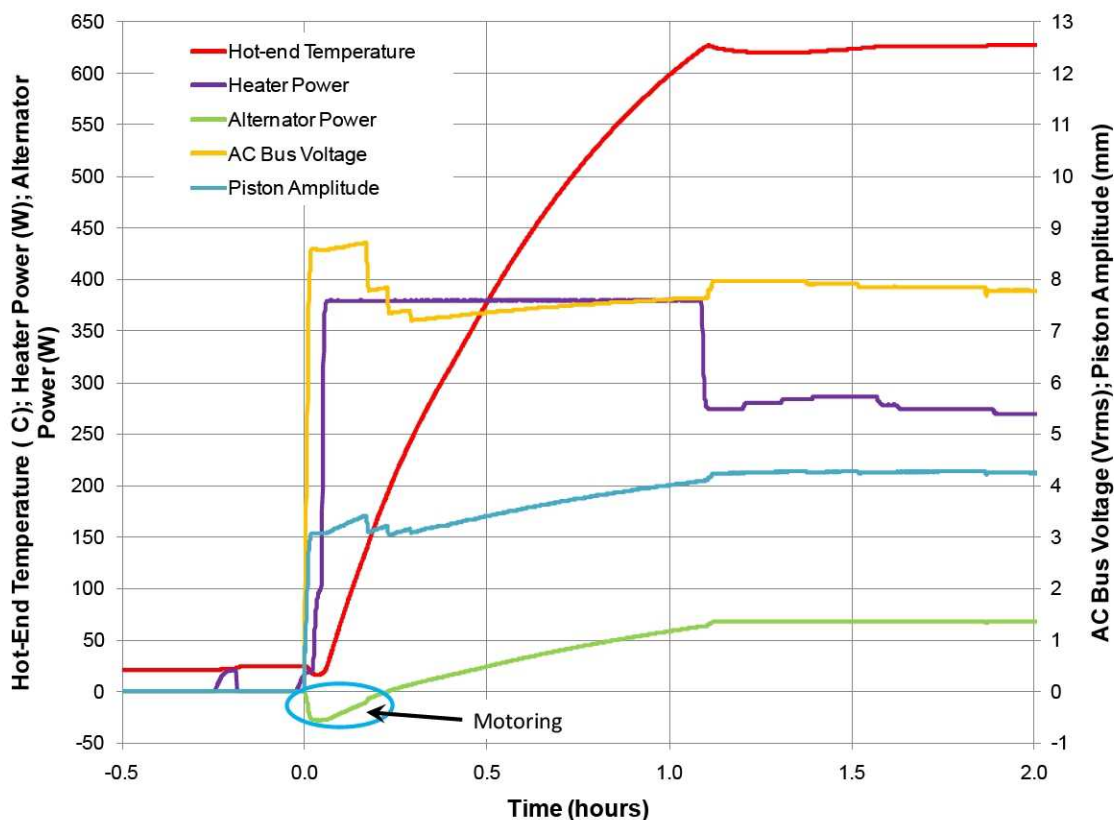

Figure 10. Start-up transient.

As the hot-end temperature increases from around 250 °C to 600 °C the piston amplitude is allowed to increase gradually to near full amplitude. Figure 10 shows that the AC bus voltage does gradually increase, although the AC power supply voltage was not changed. As currents change in the AC bus circuit, the small impedances in the lines cause the AC bus voltage to the convertors to change. (A similar effect was observed in Fig. 5 and discussed earlier.) But even if the AC bus voltage had been maintained constant, the piston amplitude still would have increased with hot-end temperature.

Finally, as the convertor approaches full temperature, the heater power is decreased to a value comparable to the output of a GPHS, and AC bus voltage is adjusted to give the desired piston amplitude and hot-end temperature at the given heat input.

Shutting down the convertors basically reverses the process. Heater power is reduced to zero. The convertors continue to run from the thermal energy stored in the heater mass and heat collector on the convertor. Eventually hot-end temperature decreases to the point where the convertors no longer produce positive power and begin to motor. This turns the convertors back into heat pumps pulling heat from the hot end. By keeping the convertors running and motoring during the shutdown process, the hot-end temperature comes down quickly. Had the convertors been stalled instead, it would take several times longer for the thermal energy to dissipate through the insulation and through conduction down the convertor heater head and to the sides of the generator. After the hot-end temperature goes below 90 °C, a safe temperature below which the convertors cannot oscillate without input power, the convertors are stalled.

#### **IV. Potential Future Efforts**

The results presented in this paper are specific to the ASRG EU. As the ASRG EU is an engineering unit, there are a number of differences between it and the expected flight configuration. While it is expected that the flight units will exhibit similar behavior as documented in this paper, the results will not be identical. Some of the differences include:

- Flight convertors can operate with a hot-end temperature up to 850 °C while the EU convertors have a maximum hot-end temperature of 650 °C
- Insulation package is slightly different
- Charge pressure is different, accounting for the higher hot-end temperature and other operating parameter differences
- Alternator voltage is higher with the flight convertors
- Flight controller algorithms are different from the EU controller algorithms.

Also, the tests discussed in this paper were performed using an AC bus controller. Because of these differences it may be beneficial to repeat these tests on an engineering unit with ASC-E2 or ASC-E3 convertors and an ACU.

Further, the ASRG will operate most of the mission in vacuum or thin atmosphere, while these tests were conducted in air. It may be beneficial to repeat these tests in a thermal vacuum environment without the argon cover gas to characterize performance with improved insulating characteristics in the generator and with radiative heat transfer from the generator sides and fins, which is more representative of the heat rejection scenario the generator will see in space.

#### **V. Conclusion**

As the ASRG moves toward flight, all aspects of the system need to be characterized and understood. Parameter variation tests on the generator provide insight into the net effects on generator performance and behavior. This information can be used to define ASRG control and management strategies prior to launch and during the mission. Further tests performed with hardware closer to the flight configuration would provide additional data to further define and finalize the system.

#### **Acknowledgments**

This work is funded through the NASA Science Mission Directorate. Any opinions, findings, conclusions, or recommendations expressed in this article are those of the authors and do not necessarily reflect the views of the National Aeronautics and Space Administration (NASA). The authors wish to acknowledge the many people who supported ASRG EU testing in the Stirling Research Laboratory at the NASA Glenn Research Center.



## References

<sup>1</sup>Chan, J., Wood, J.G., and Schreiber, J.G., “Development of Advanced Stirling Radioisotope Generator for Space Exploration,” proceedings of *Space Technology and Applications International Forum (STAIF 2007)*, edited by M.S. El-Genk, AIP Conference Proceedings 880, pp. 615-623,2007.

<sup>2</sup>Chan, J., Hill, D., Hoye, T, and Leland, D., “Development of Advanced Stirling Radioisotope Generator for Planetary Surface and Deep Space Missions,” *Proceedings of the Sixth International Energy Conversion Engineering Conference (IECEC 2008)* American Institute for Aeronautics and Astronautics, 2008.

<sup>3</sup>Lewandowski, E.J., Schreiber, J.G., Oriti, S.M., Meer, D.W., Brace, M.H., and Dugala, G., “Design of a Facility to Test the Advanced Stirling Radioisotope Generator Engineering Unit,” *Proceedings of the Seventh International Energy Conversion Engineering Conference (IECEC 2009)* American Institute for Aeronautics and Astronautics, 2009.