

NASA Earth Observations Resources

William L. Stefanov

Science Applications, Research and Development/ESCG

william.l.stefanov@nasa.gov

Cynthia A. Evans

ISS Program Science Office

cindy.evans-1@nasa.gov

Rajib Dasgupta

ISS National Laboratory Payloads Office

rajib.dasgupta-1@nasa.gov

NASA Johnson Space Center, Houston, TX USA





Introduction

- **ISS has significant utility as an Earth Remote sensing Instrument test bed.**
 - Remote Sensing is one of the major thrust areas for Utilization of ISS as a US National Laboratory
- **ISS Orbital Characteristics**
- **Window Observational Research Facility (WORF)**
- **Existing Earth Viewing Systems**
 - Pressurized
 - International Space Station Agricultural Camera (ISSAC) – in WORF
 - Crew Earth Observations (CEO)
 - Unpressurized
 - Hyper-spectral Imager for the Coastal Ocean (HICO)
- **Planned Earth Viewing Systems**
 - Pressurized
 - ISS SERVIR Environmental Research and Visualization System (ISERV) – in WORF
 - Unpressurized
 - Cloud Aerosol Transport System (CATS)
 - High Definition Earth Viewing (HDEV)

Sun-Synchronous Polar Orbits vs. Inclined Equatorial Orbits

Polar orbit

- Sun-synchronous – designed for long term repeatability of data
- Typically nadir viewing, crosses every point on Earth ~ 12-14 days near local solar noon/local midnight
- Landsat series collecting data since 1972
- Pointing capability, satellite constellations

Inclined Equatorial Orbit: ISS

- Sun-asynchronous – similar illumination 3-4 days every 90 days
- Nadir to highly oblique imagery possible from hand-held cameras, WORF
- Provides opportunity to collect unique datasets for scientific study, operational monitoring
- Data is complementary to polar-orbiting satellite data

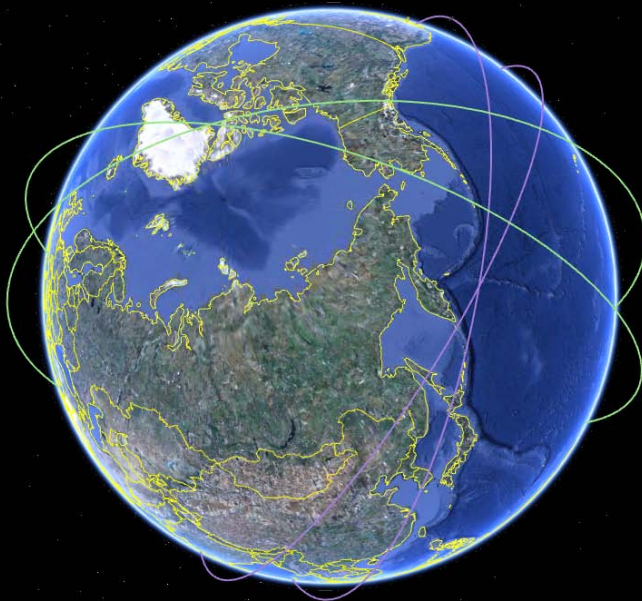

© 2009 Tele Atlas
© 2009 Europa Technologies
US Dept of State Geographer
Data SIO, NOAA, U.S. Navy, NGA, GEBCO
lat 68.379988° lon 141.379620° elev 174 m

Google
Eye alt 12716.84 km



© 2009 Tele Atlas
© 2009 Europa Technologies
US Dept of State Geographer
Data SIO, NOAA, U.S. Navy, NGA, GEBCO
lat -7.099029° lon -90.049120° elev -4040 m

agj

Google
Eye alt 12716.84 km

ISS Orbit = Variable Image Acquisition Times

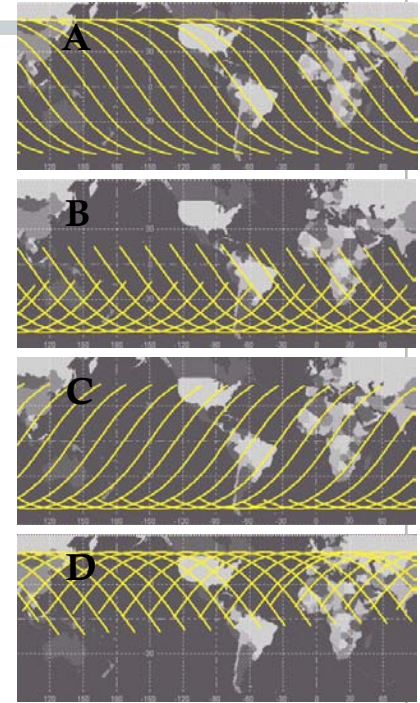
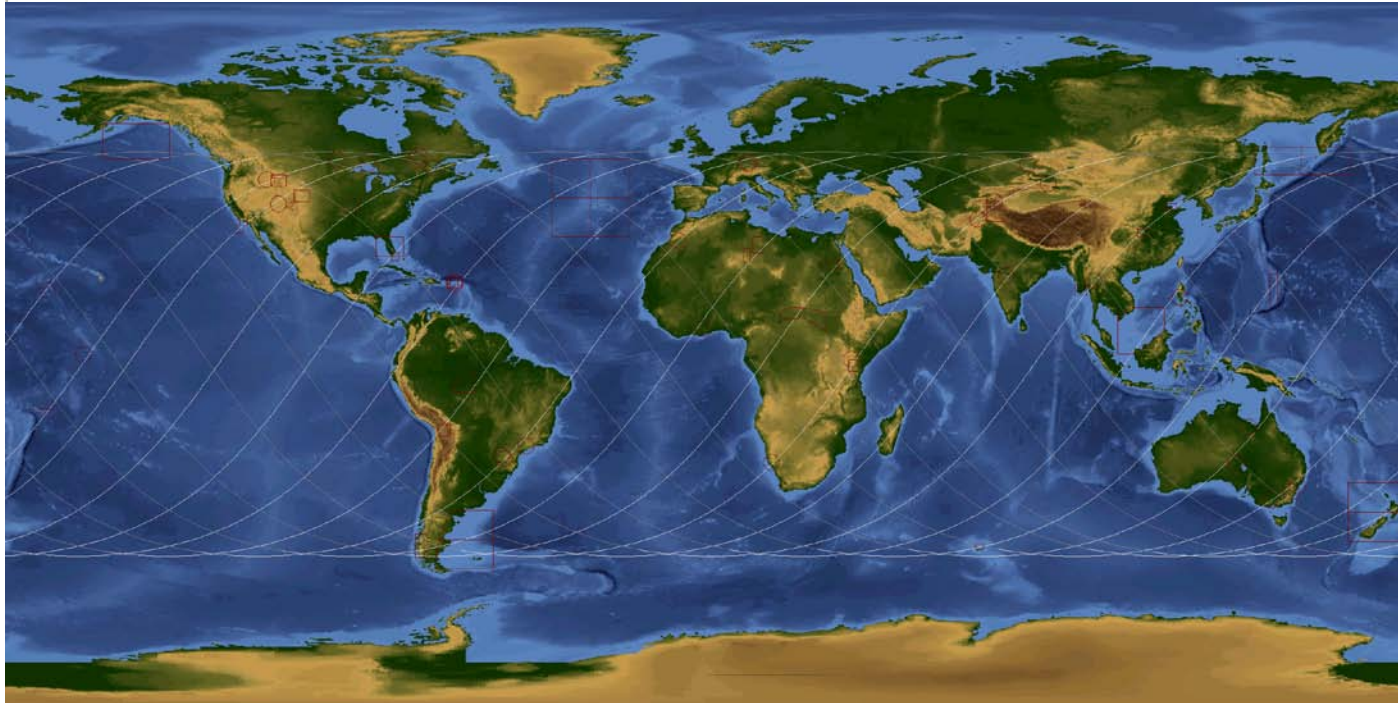

Unlike polar-orbiting satellites such as Landsat or Terra, the International Space Station (ISS) has an inclined equatorial orbit that is not sun-synchronous.

This type of orbit limits nadir viewing opportunities to approximately 52N and 52S latitudes, and results in variable ground illumination.

- Daylight Orbits on ISS:
- A – Successive ISS orbit paths, descending passes.
 - B – Daylight illumination in Southern Hemisphere only.
 - C – Successive ISS orbit paths, ascending passes.
 - D – Daylight illumination in Northern Hemisphere only.



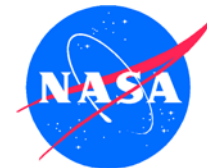

Internal Payloads

NASA Facility – WORF

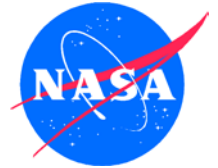

Window Observational Research Facility

http://www.nasa.gov/mission_pages/station/research/experiments/WORF.html

- rack facility positioned over the US Destiny Lab module window (nadir-viewing)
- Station power and data connections, and multiple rack mounting options to support still and video cameras, multi/hyperspectral imagers, other instruments
- WORF shroud provides lighting control, secure payload space
- can support multiple instruments at the same time, and rapid instrument exchange
- window has high transmissivity (>90%) from 0.34 – 0.80 μm ; drops off to 50% transmissivity between .80 and 1.3 μm

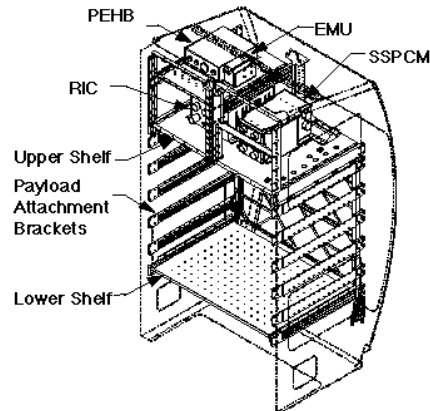

Expedition 27 astronaut Ron Garan working with ISSAC system and WORF. 6-May-2011.

NASA Payloads - ISSAC



Sensor: ISS Agricultural Camera,
internal (WORF)

Type: paired digital line-scan cameras with filters

Pointing capability: 30 degrees cross track

Geometric resolution: 20-30 meters

Spectral resolution:

visible green (0.52 – 0.60 μm)

visible red (0.63 – 0.69 μm)

near infrared (0.77 – 0.90 μm)

Scene Size: 21 km x 16 km at nominal altitude

Data georeferencing: automated, to order of 500 meters accuracy. Manual georeferencing possible to achieve 20 – 60 meter accuracy.

Output file format: standard Geotiff

Data take to availability time:

~ 24 – 48 hours

Data availability: Public

<http://dngp.umac.org/>

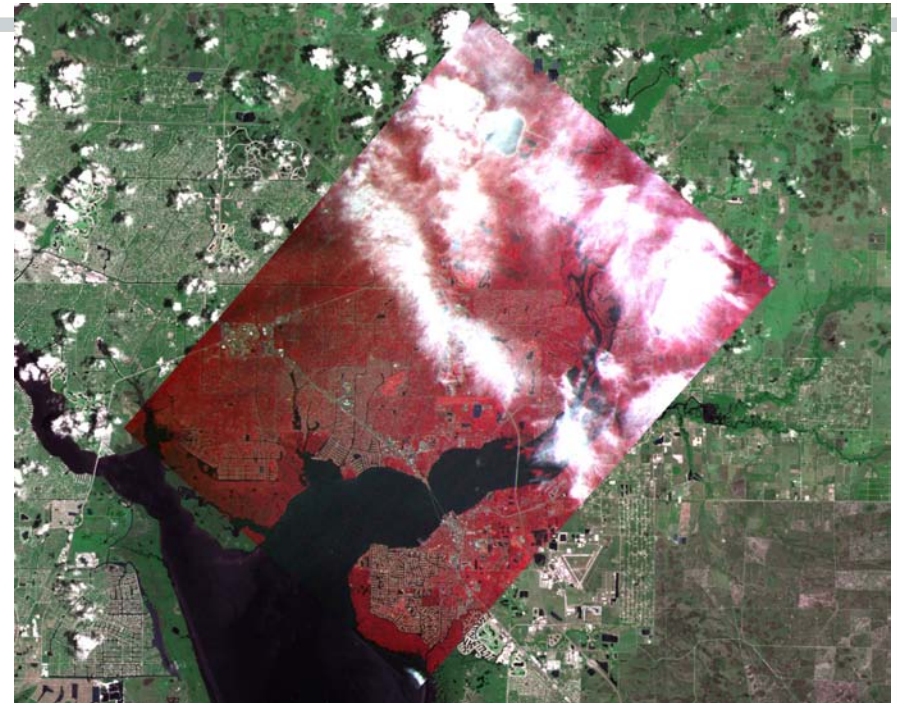

Top: ISSAC first light image; NIR, red, green (RGB); Charlotte Harbor, FL on Landsat 5 base image, 10-June-2011.

Left: ISSAC system in the WORF Ground Test Rack, NASA JSC.

NASA Payloads - CEO

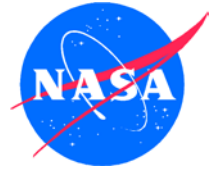

Sensor: COTS digital cameras, internal

Type: CCD

Pointing capability: yes, dependant on window and lens

Geometric resolution: variable, depends on lens
< 3 m/pixel with 1000 mm lens to > 30 m/pixel with 110 mm and shorter lenses

Spectral resolution: visible RGB, poorly constrained bandpass
(potential for NIR imagery using modified camera)

Scene Size: variable, depends on lens, ISS altitude

Data georeferencing: manual

Output file format: raw camera formats, JPEG, camera file with Meta data.

Data take to availability time:
~ 24 hours for full resolution data,
may be possible to expedite

Data availability: Public
<http://eol.jsc.nasa.gov>



Top: Expedition 21 astronaut Nicole Stott working CEO in Zvezda, 15-Nov-2009.
Left: Sahara Desert as seen through the ISS Cupola, 17-Feb-2010

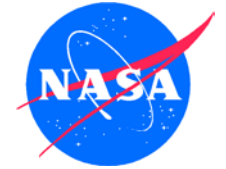

NASA Payloads - CEO



Fire plume in the Chiricahua Mountains, AZ; [ISS027-E-31908](#), May 15, 2011, Nikon D3S, 200 mm lens



Higashimatsushima, Japan; [ISS026-E-33647](#), March 13, 2011, Nikon D2Xs, 800 mm lens



Sarychev Peak eruption column, pileus cloud, and pyroclastic flows; [ISS020-E-9048](#), June 12, 2009, Nikon D2Xs, 400 mm lens



Mississippi River flooding, MO and TN; [ISS027-E-27023](#), May 12, 2011, Nikon D2Xs, 400 mm lens

Planned NASA Payloads - ISERV



Sensor: ISS SERVIR Environmental Research and Visualization System, internal (WORF).
Manifested on SpaceX flight, 2012.

Type: Schmidt-Cassegrain telescope with Canon Digital SLR camera on mount

Pointing capability: 23 degrees along and cross-track

Geometric resolution: < 3 meters nominal

Spectral resolution: visible RGB, poorly constrained bandpass; may be upgraded to include NIR with more sophisticated imager (0.35 – 0.80 microns)

Scene Size: 14.4 km x 9.6 km at 350 km altitude

Data georeferencing: unknown, may be possible to semi-automate with photogrammetric techniques

Output file format: raw camera format, JPEG (?)

Data take to availability time:
~ 3 hours nominal

Data availability: Public, through SERVIR nodes or other portals.



ISERV system, including Canon EOS 7D camera body; Celestron 925 CPC telescope tube and 800 CPC pointing mount; and Hyperstar 3 lens

ISERV/SERVIR Applications



- Disaster Analysis
- Environmental Monitoring
- Air Quality and Public Health
- Climate Change and Biodiversity
- Short Term Weather Prediction

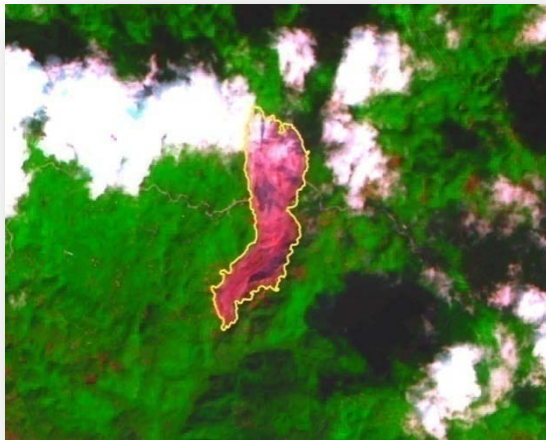
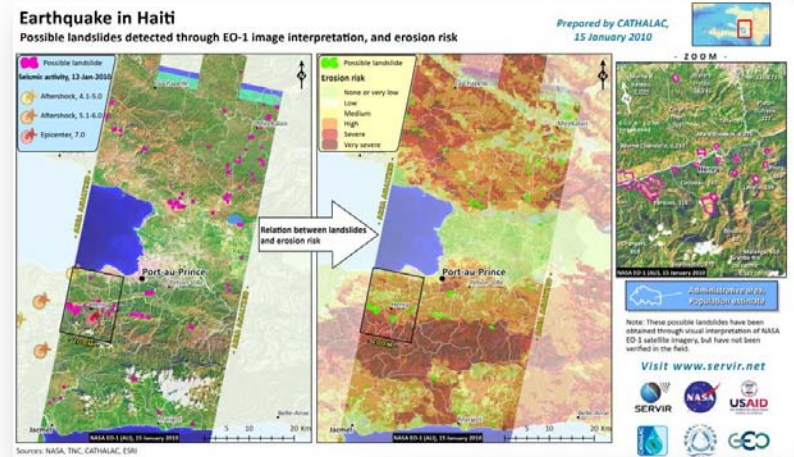

Landslide Mapping in Guatemala
January 2009



Fires in Guatemala and Mexico
April 2009

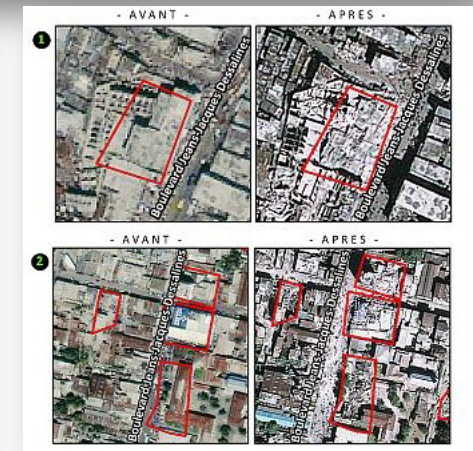

Earthquake Damage Assessment,
Haiti January 2010



External Payloads

ISS External Research Facilities

(ULF6, 2011)

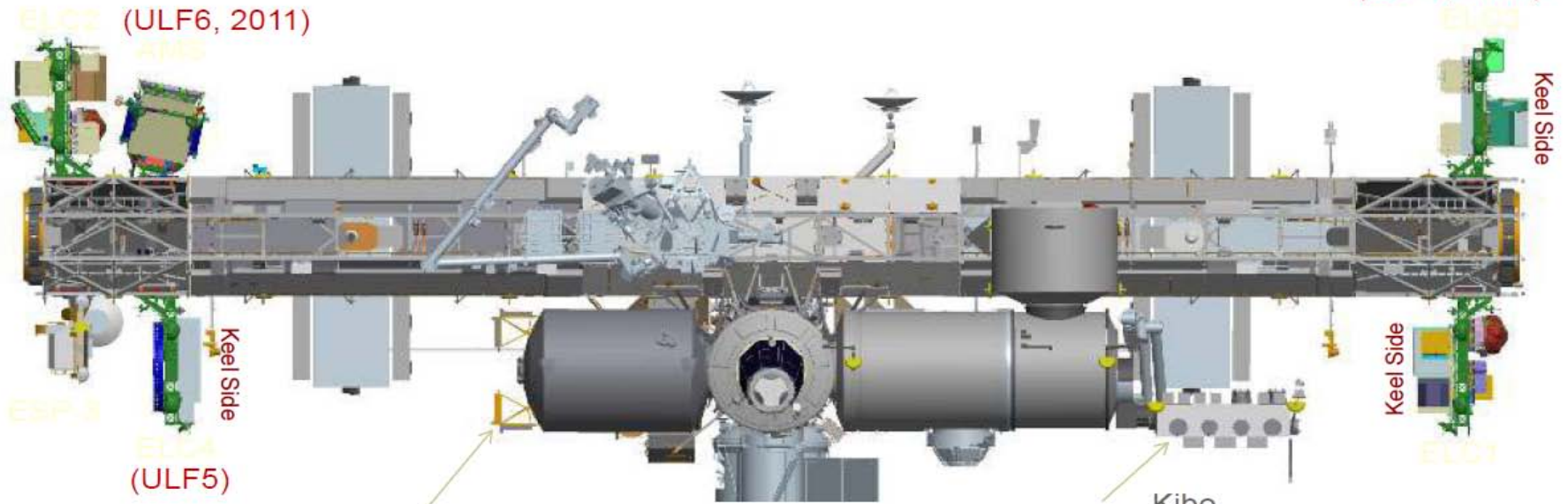

Columbus
External Payload Facility
(2 sites NASA, 4 sites total)

Kibo
External Facility
5 sites NASA, 10 sites total



National Aeronautics and Space Administration

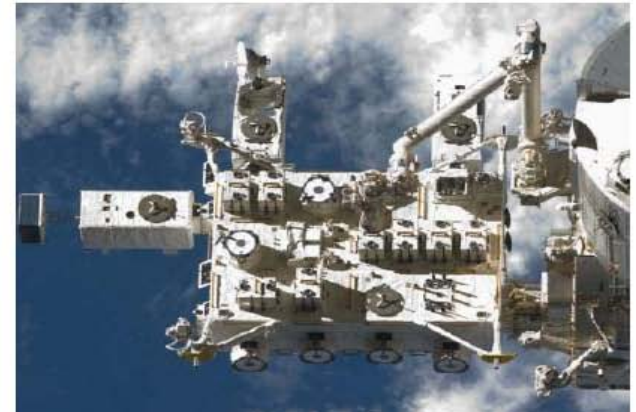

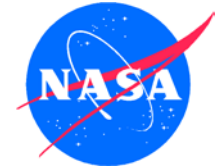

NASA Payloads - HICO

Sensor: Hyperspectral Imager for the Coastal Ocean, external (JEM-EF)

Type: imaging spectrometer

Pointing capability: 45 degrees left of track,
30 degrees right of track

Geometric resolution: 90 meters nominal

Spectral resolution: 0.40 – 0.90 μm
87 useable bands, 5.7 nm resolution

Scene Size: 42 km x 192 km at nominal altitude

Data georeferencing: automated, rough
geolocation in real time; improved geolocation
data available 1-7 days later.

Output file format: BIL, BSQ with metadata

Data take to availability time: 48 hours.
Only 1 HICO scene/orbit, maximum 15 scenes/day

Data availability: By registered user request. Only data
requested by user is available through HICO archive.

<http://hico.coas.oregonstate.edu/datasearch/data-search-basic.php>

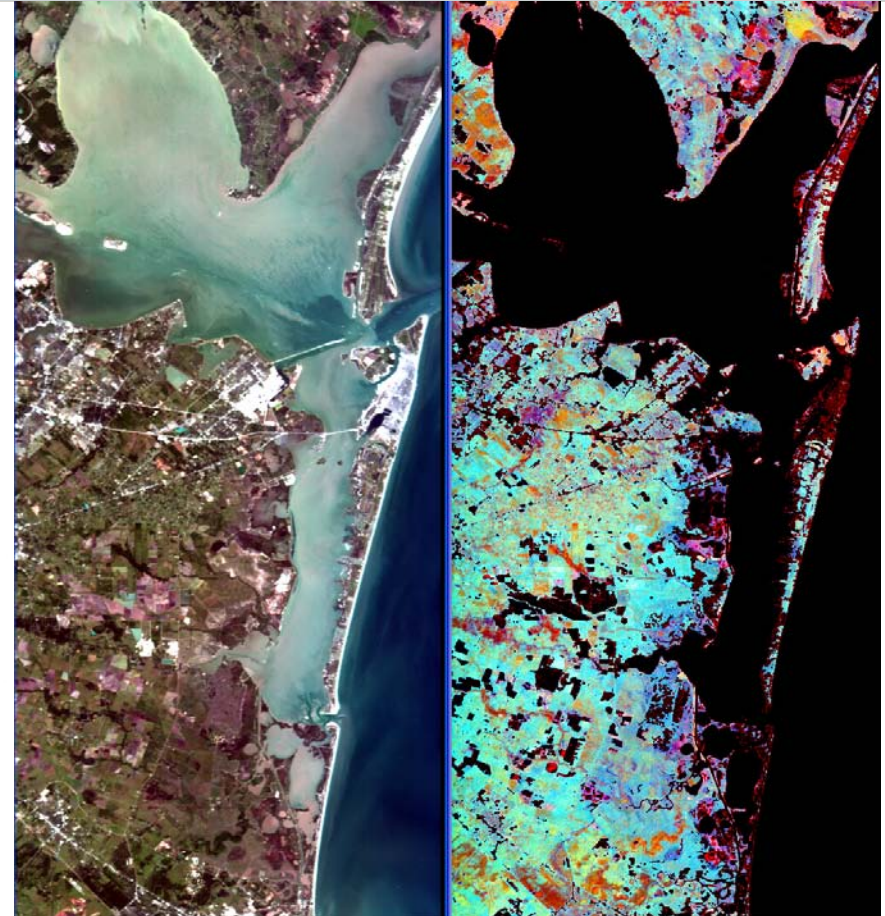

HICO data for Galveston Bay area, TX;
Left: RGB image. Right: water band (R),
carotenoid reflectance (G), anthocyanin
reflectance (B). 5-May-2011

Planned Cloud Aerosol Transport System (CATS)

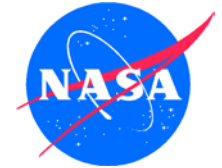

- Cloud Physics LIDAR Instrument. Demonstrate multi-wavelength aerosol and cloud retrievals; planned for 2013 launch
- Provide cloud and aerosol data to help bridge the gap between CALIPSO and future missions (ACE).
- Enable aerosol transport models by using real-time data downlink from ISS
 - The ability of an aerosol plume to transport long distances is determined by its injection height relative to the local PBL.
 - Passive aerosol measurements from space provide valuable constraints on column aerosol loading. However, models lack observational constraints on vertical distribution.
- ISS orbit is useful for tracking plumes and study of diurnal effects (not possible with A-Train orbit).

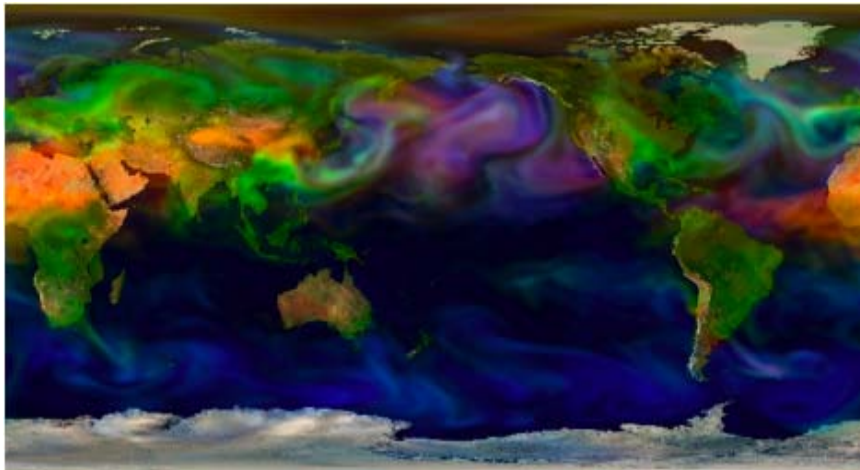

Snapshot of GEOS-4 model global aerosol distribution forecast for March 20, 2006. Orange = dust; Blue = sea salt; Green = smoke and sulfate; Saturation \sim species column amount

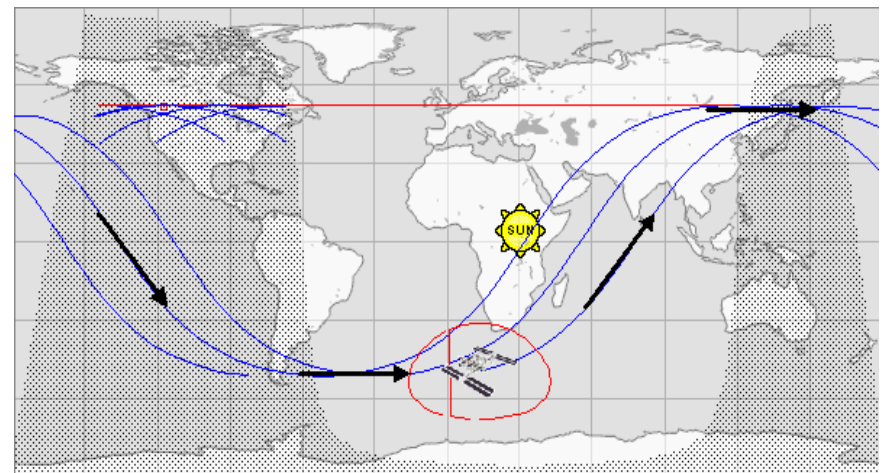

ISS orbit. The orbit inclination permits extensive measurements over aerosol source and aerosol transport regions.

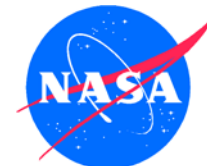

Planned CATS-ISS Payload Hardware

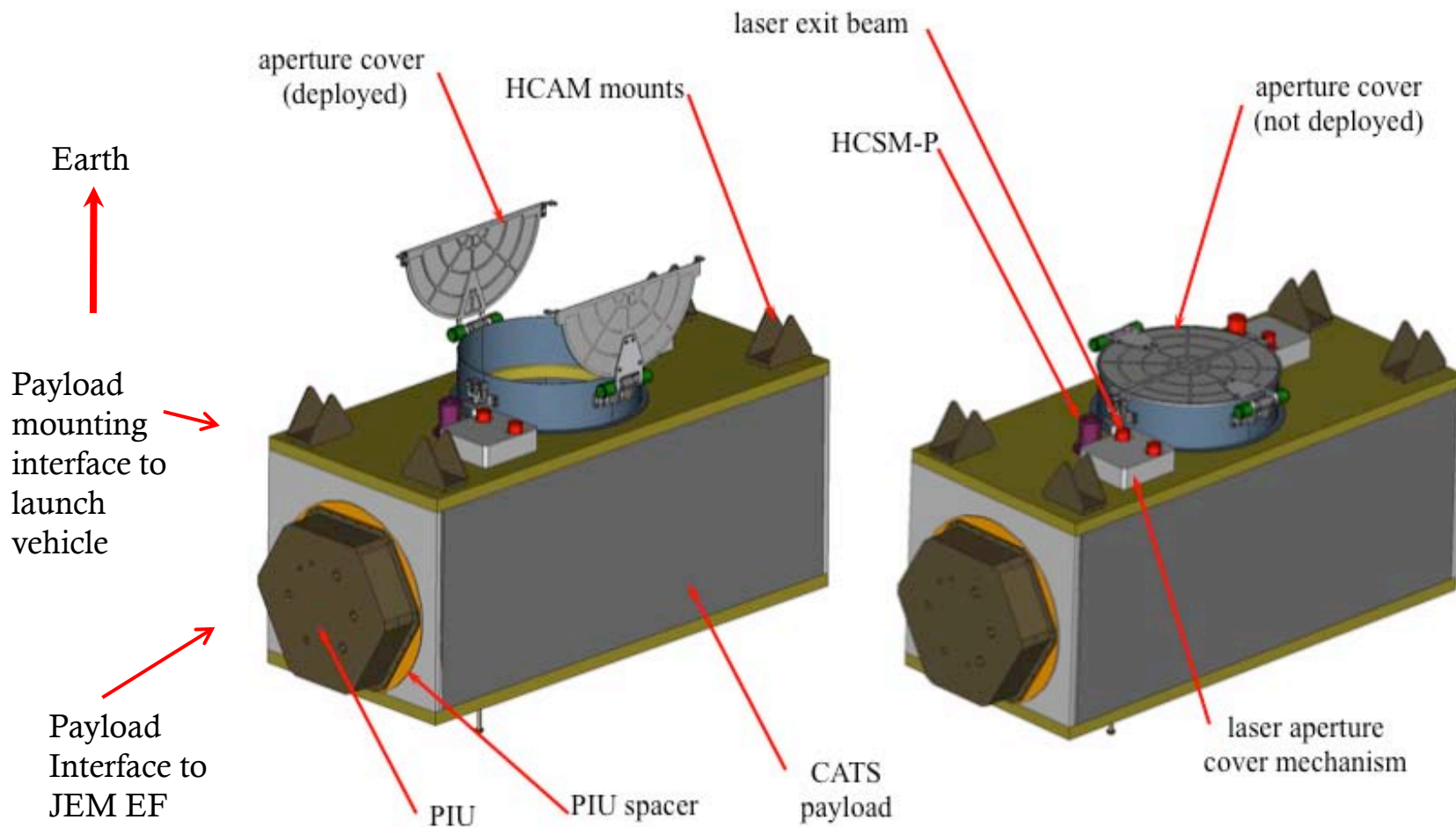

Standard JEM-EF payload volume: 1.855 x 0.800 x 1.299 m.



NASA Payloads – HD Video

ISS External Camera Ports Reference On-orbit

July 21, 2010

Legend:

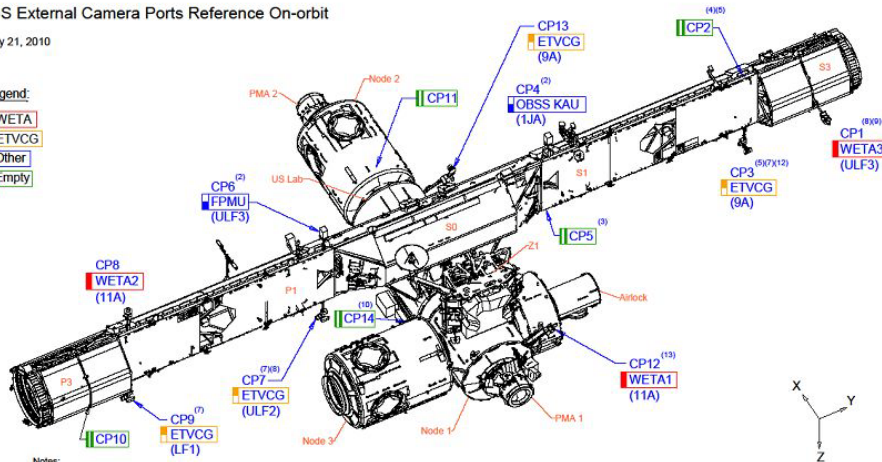

Notes:

- (2) The use of the S1 Inboard Upper (CP4) and P1 Inboard Upper (CP6) camera ports should be minimized due to potential camera damage from S-Band antenna radiation.
- (3) The S1 Inboard Lower (CP5) camera port is unavailable when ESP-2 is attached to the Airlock forward trunion due to physical clearances.
- (4) S1 Outboard Upper (CP2) camera port is unavailable when AMS is attached to S3 Upper Inboard PAS due to magnetic field interference issues with ETVCG and WETA.
- (5) ELC cargo layout should be optimized to maximize clearance between the camera, including sweep envelope, and the ELC cargo.
- (7) HTV camera requirement for proximity and capture operations: Primary pair - CP3 & CP7; Back-up pair - CP3 & MBS mast camera at W55; Back-up pair - CP9 & MBS mast camera at W55.
- (8) Installed during Flight.
- (9) Get ahead task.
- (10) CP14 stanchion mount is available for structural attachment, but clearance issues with ESP1 exist. The port is not functional due to lack of wiring on Node 3.
- (11) R&R CP13 Luminaire at 19A.
- (12) Installation of wedge at CP3 mounting location planned for ULF5 to angle the ETVCG away from the S3 PAS site, but still retain HTV Crew Monitoring capability.
- (13) Close clearances to the installed 5th Airlock tank if R&R is required.



HD video may represent another dataset of interest and use for atmospheric or other climate-related research (volcanic eruptions, flooding from high precipitation, wildfires, hurricane/tsunami, power outages/brownouts)

JSC Imagery Working Group involved with several initiatives:

- Continuous HD downlink of Earth views (HDEV) (720p)
- Support for JAXA SSHD
- Canon HDV camcorder onboard ISS

Issues to consider – data throughput on ISS LAN, downlink pipeline; ground storage of video, long term support for capability

Frame grabs from “What an Astronaut’s Camera Sees”, HD video captured in 2008 from the ISS. Produced by JSC Public Affairs Office.



Planned HDEV (High Definition Earth Viewing) Payload

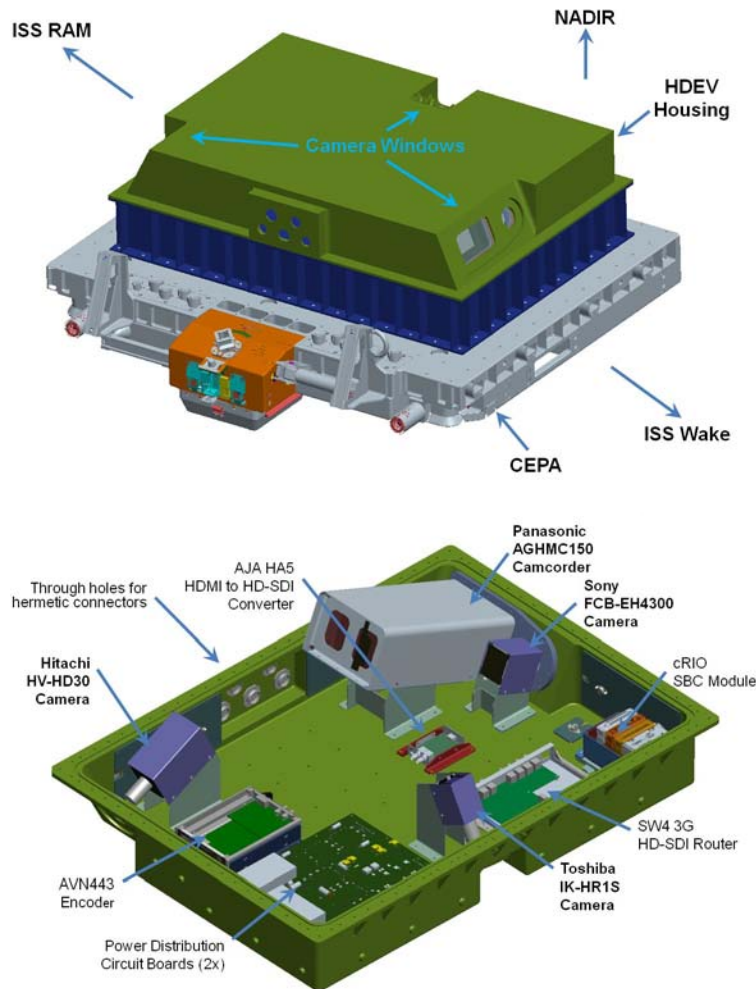

- The objective of the investigation is to evaluate different HD camera technologies in the LEO environment and in the process, provide high definition views of the Earth to interested parties and the public at large
- Launching on SpaceX 3 in 2012

COTS Parts

Cameras:

- Toshiba IK-HR1s
- Hitachi GV-HD30
- Panasonic AGHMC150
- Sony FCB-EH4300

Router

- Extron SW4 3G HD-SDI

Encoder

- Visionary Solutions AVN443

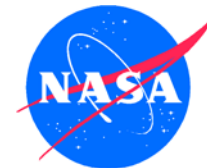

BACKUP SLIDES

CEO Daily Target Message Ops

1. Potential targets determined using predicted ISS orbit ground tracks and defined areas of interest (+ 24 hours)
 - Dynamic event targets added manually
 - **CEO ops performed Monday - Friday**
2. Target list screened for viewing conditions, crew and ISS constraints (**cloud cover, sun angle, viewing angle, crew wake/sleep, ISS maneuvers**) - *these conditions have so far precluded acquisition of northern Japan test site*
3. Final target list composed, with supporting data
4. Target list reviewed and uplinked through MSFC pipeline, available for crew review prior to scheduled wake time
 - * **Operational considerations for rapid response and image acquisition**

Earth Observations Station Message for 17-SEP-2010
 Message Generated: 16-SEP-2010

Onboard CEO reference documents: 24-0453P (Site List), 24-0454P (Overview), 24-0455P (Science Plan)

17-SEP-2010/GMT Day 260

GMT	Site	Lat	Lon	Lens
13:42:44	Hurricane Igor, Atlantic Ocean	21.2N	66.4W	180

Dynamic Event. Hurricane Igor remains a large, powerful storm that is currently predicted to pass over or close by Bermuda (Fig. 7). Look to the right of track for the center of the storm; there should be a well-formed eye visible. The closest approach is lat: 22.67, lon:-65.08 at 13:43:15.

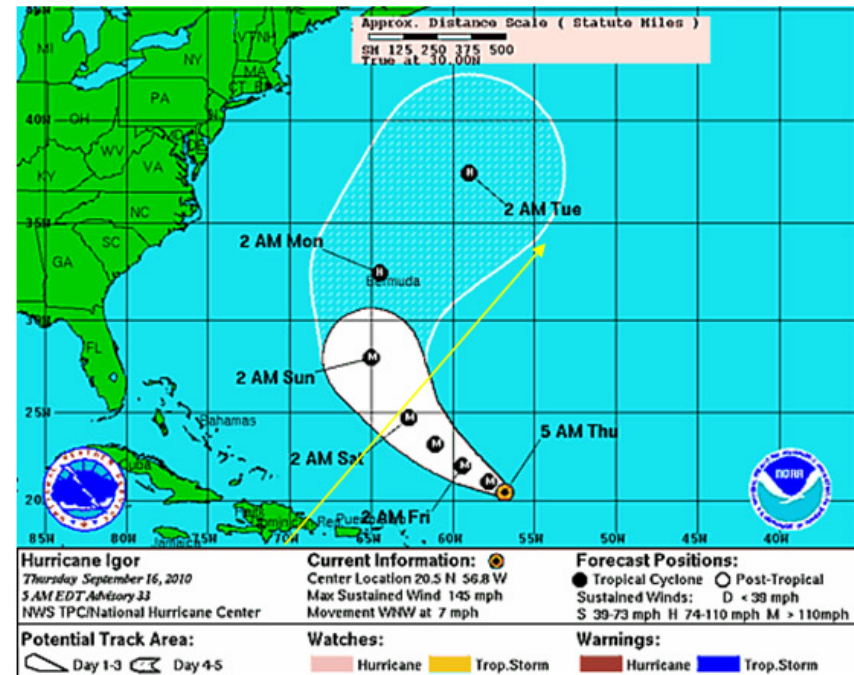
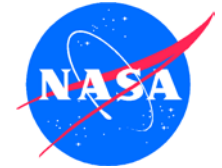

Figure 7. NOAA predicted storm track for Hurricane Igor. The yellow arrow indicates your approximate orbit track.



CEO Process Following Target Uplink to Crew

1. CEO is a task-listed activity, therefore taking imagery with the handheld cameras at the designated times is **at the crew's discretion**.
2. Imagery must then be copied from the camera back storage card into a specific downlink folder on a Station computer hard drive - **timely placement of files for downlink** is the responsibility of the crew.
3. Downlinked imagery classified as Earth Obs is then ingested by the CEO team and parsed into Priority 1 - imagery taken in response to a specific target request, as identified by the camera image file time; or Priority 2 (all other imagery). Note that neither the JSC Building 8 or CEO teams have the resources to provide 24/7 ground support. **Priority 1 imagery is reviewed and cataloged by the CEO team, and added to the online database for public access.**
4. Once imagery has been cataloged, automated email notification to interested parties is possible. At the present time CEO does not have a capability for automated notification based on Priority 2 imagery.
5. Other notification mechanisms involve direct communication from the crew themselves. CEO has occasionally received advance notice of imagery from the crew through comments made during DPCs, direct email communication, or even seeing imagery of events on astronaut's Twitter feeds. But again, all of this is informal.

*** Operational considerations for rapid response and image acquisition**

Lidar (CPL) Data Example

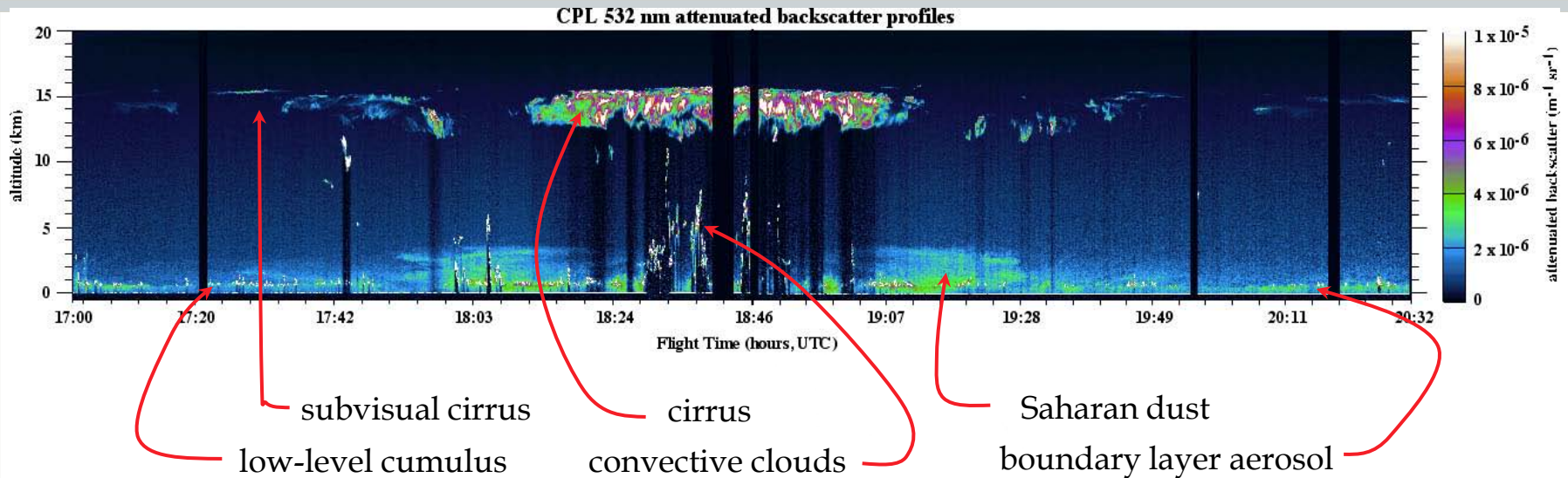

Lidar profiling generates a time-height cross-section of the atmosphere, revealing cloud and aerosol structure.

Multiple cloud/layer features can be measured, *up to the limit of signal attenuation* (O.D. 3-4).

From this data we derive layer boundaries, optical depth, extinction, and depolarization, and at least a coarse discrimination of aerosol type (e.g., smoke, dust, pollution).

The CPL web site is: <http://cpl.gsfc.nasa.gov>