



Spacecraft Applications for Aneutronic Fusion and Direct Energy Conversion



Project Team:

Jeff George

NASA/JSC-Energy Conversion Systems Branch

Paul March

Engineering Support Contract Group/Houston

George Miley, Ph.D.

University of Illinois, Urbana-Champaign/Dept. of Nuclear, Plasma, and Radiological Engineering

John Scott *Project Lead*

NASA/JSC-Energy Conversion Systems Branch

Alfonso Tarditi, Ph.D.

Electric Power Research Institute/Knoxville-Houston

H. "Sonny" White, Ph.D.

NASA/JSC- Propulsion Systems Branch



Changing the Game in Space Exploration

Human Mars Exploration must change from a 3-year epic event to an annual expedition.

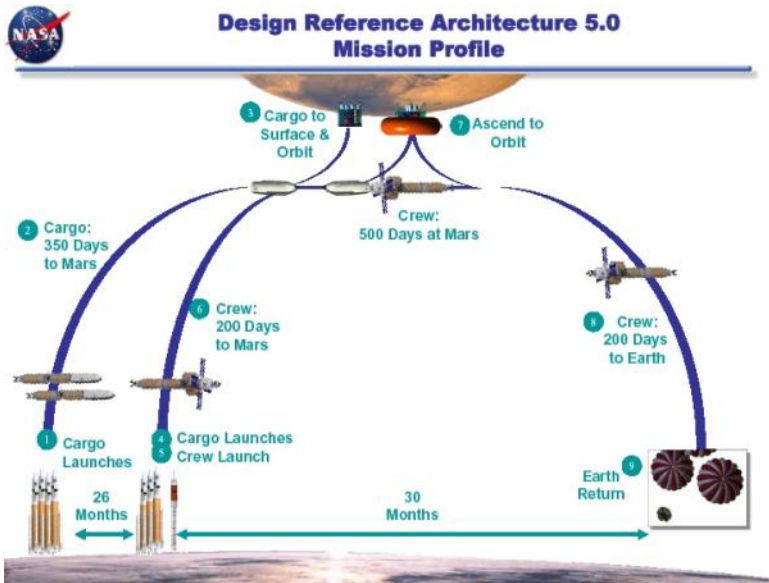

Conjunction Class Missions
(900 day total)

Mars Architecture Study 5.0:
Nuclear Thermal Propulsion
Piloted Vehicle w/ 50 MT Habitat
350 MT IMLEO
Vehicle disposed upon return

NASA/SP-2009-566

Opposition Class Missions
Nuclear Electric Propulsion
Split Mission; ECCV Return
Piloted Vehicle w/ 40 MT Habitat
30-day Surface Stay
Vehicle disposed upon return

George et al, "Piloted Mars Mission Planning: NEP Technology and Power Levels," 10th Symposium on Space Nuclear Power Systems, Albuquerque, 1993.

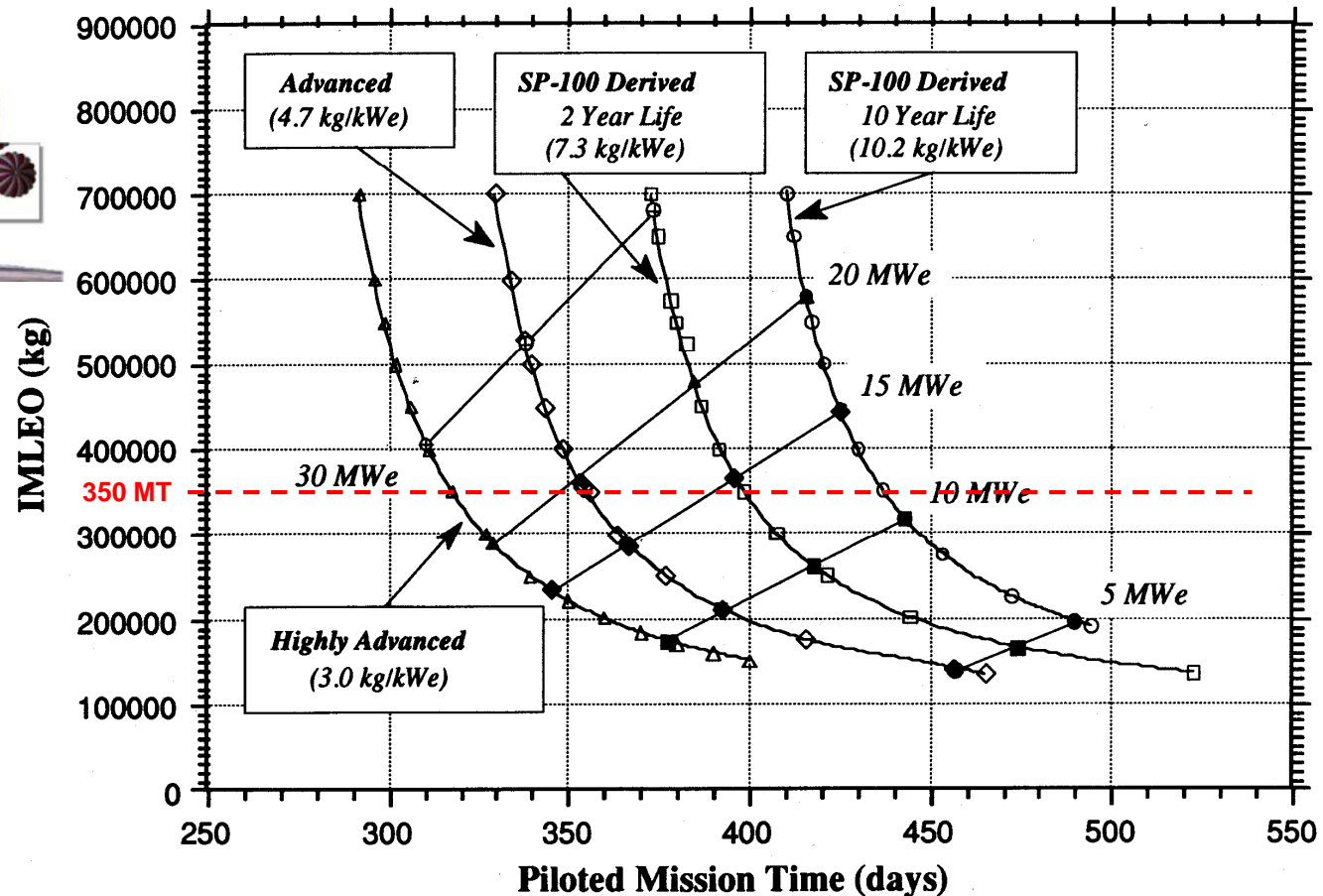



Draft Technology Roadmap

TA03 Power & Energy Storage Technology Roadmap



MISSION APPLICATIONS:

Emphasis

YEAR:

2010 2015 2020 2025 2030

- SOMD/ESMD Missions
- SMD Missions
- Aeronautics Missions
- New Capabilities

Legend:

- ▲ = Interim milestone
- ▲ = Technology at TRL 6
- ▲ = 1st Mission Potential
- ▲ = Missions Envisioned
- ▲ = Propulsion Integration

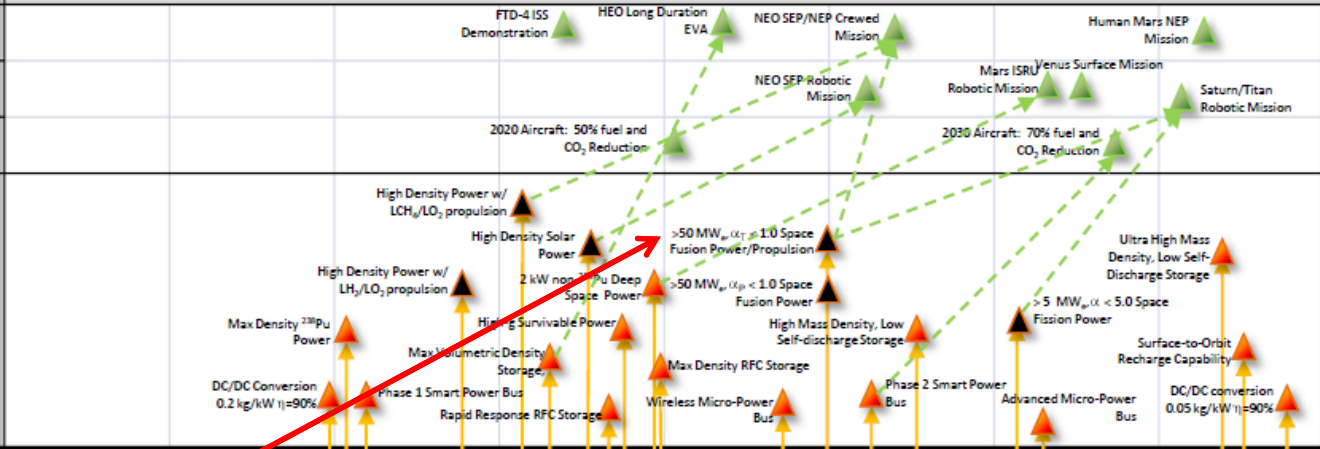

POWER TECHNOLOGIES:

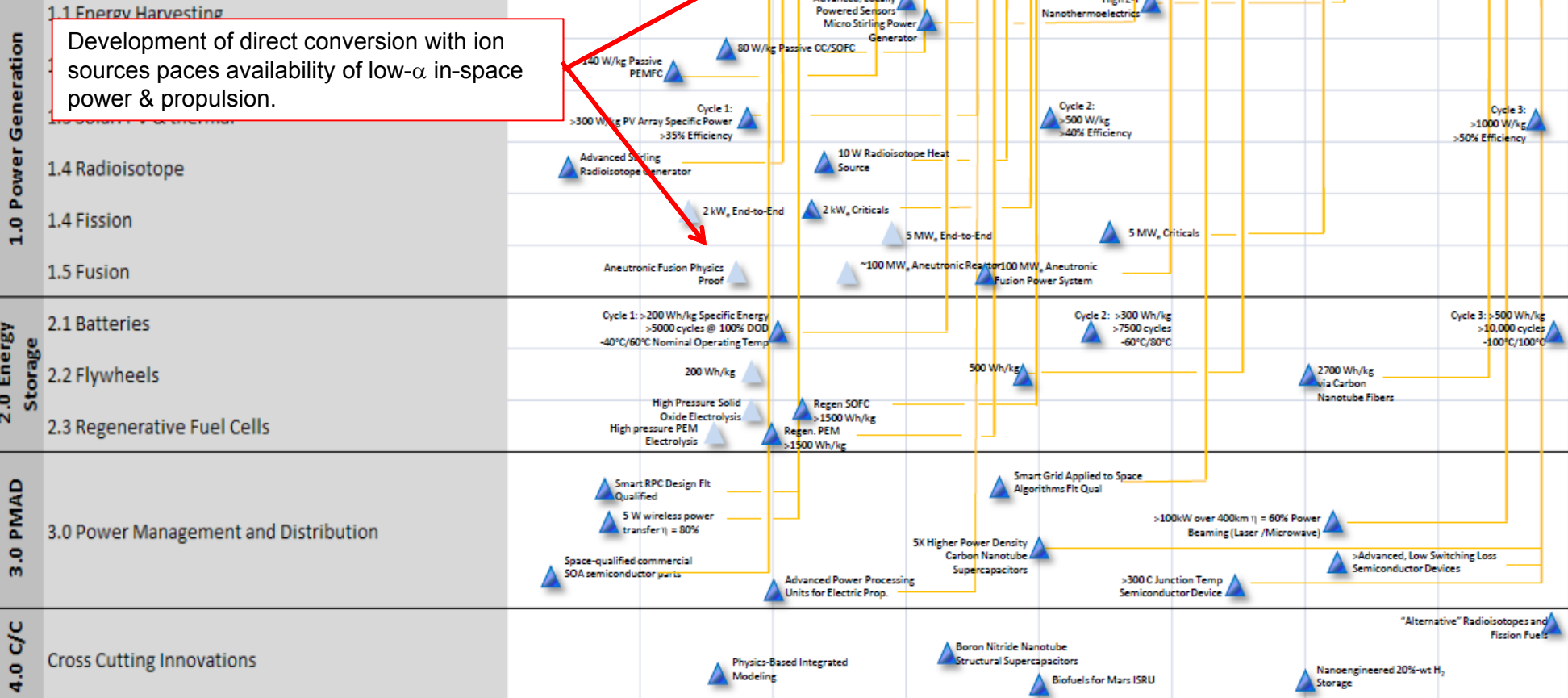



The Problem

Direct energy conversion technology is key to attaining low- α in-space propulsion

A generic multi-MW configuration:

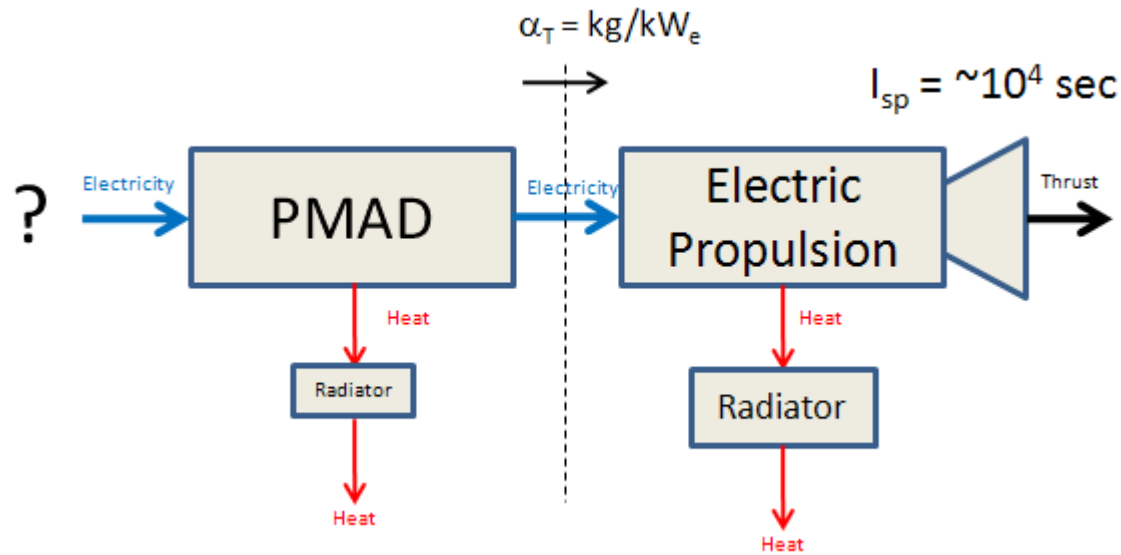



The Problem

Direct energy conversion technology is key to attaining low- α in-space propulsion

Multi-MW heat sources (e.g., NEP) can enable moderate α .

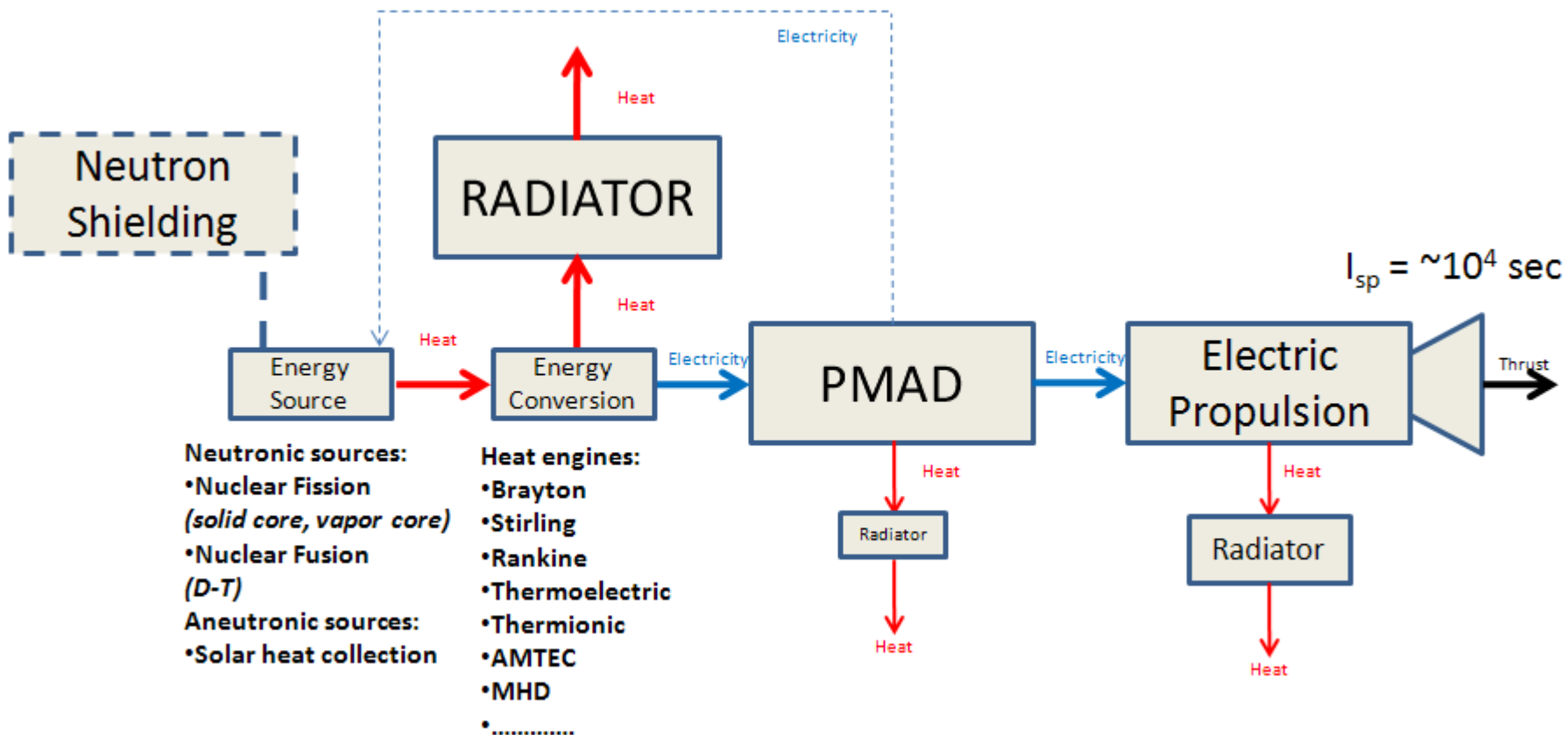



The Problem

Direct energy conversion technology is key to attaining low- α in-space propulsion

Multi-MW ion sources with direct conversion can enable lower α .

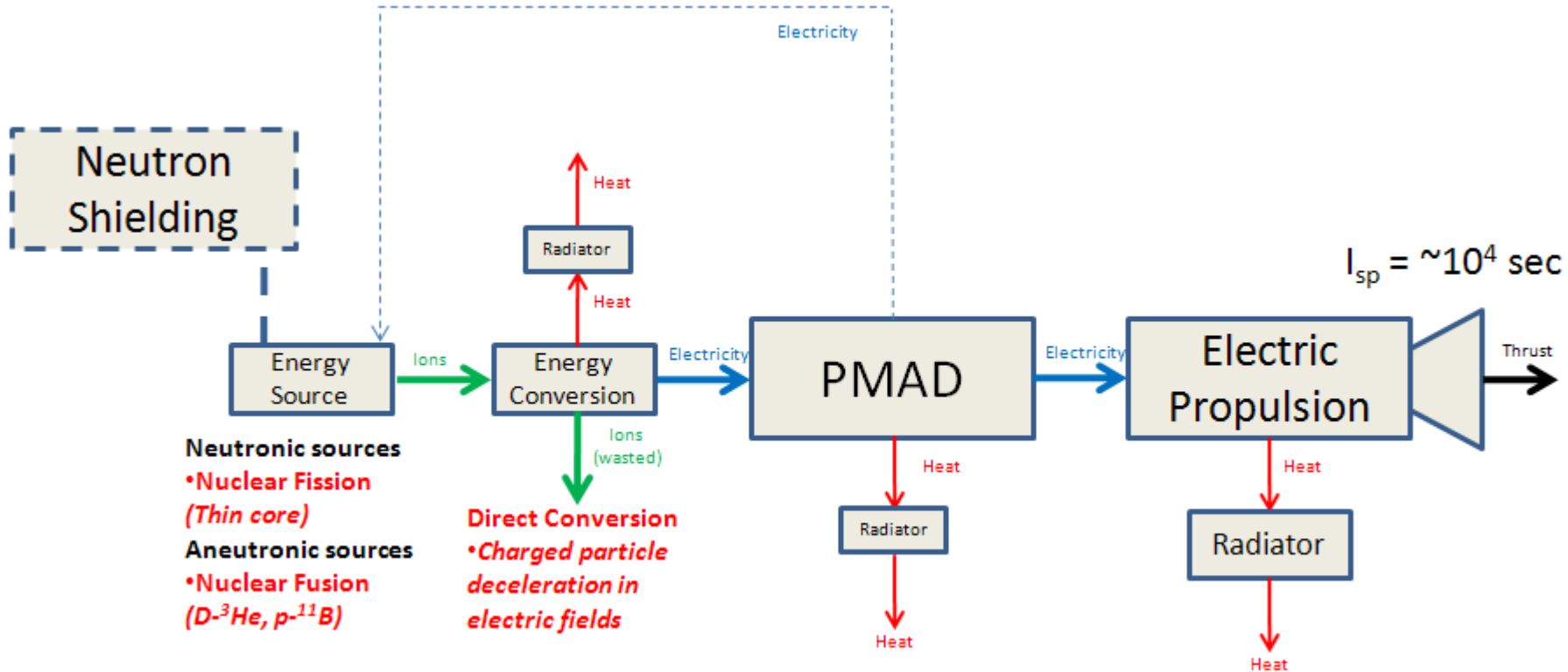



The Problem

Direct energy conversion technology is key to attaining low- α in-space propulsion

Multi-MW ion sources with TWDEC can enable low α :

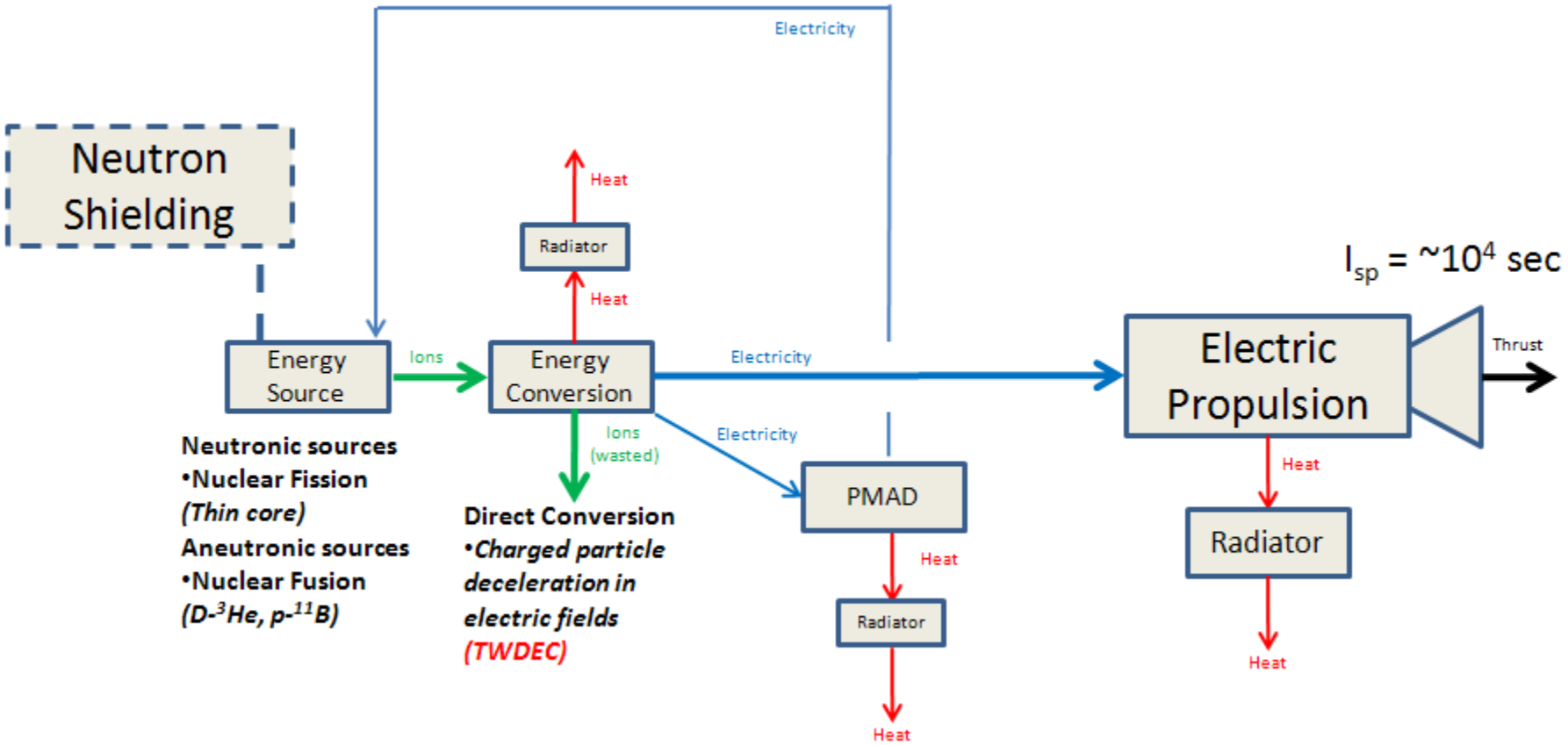



The Problem

Direct energy conversion technology is key to attaining low- α in-space propulsion

Multi-MW ion sources with TWDEC and direct propulsion conversion can enable lowest α .

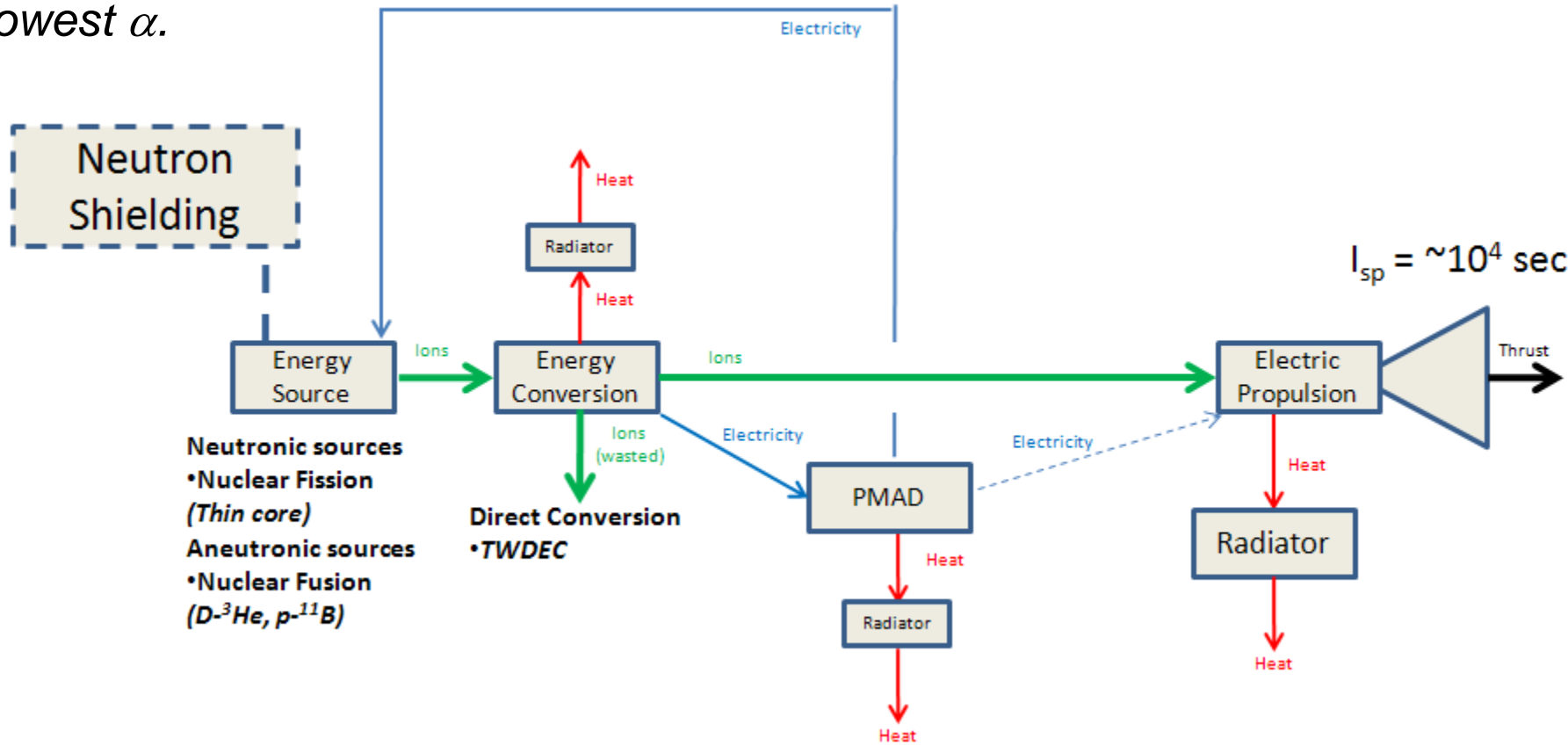



The Problem

Direct energy conversion technology is key to attaining low- α in-space propulsion

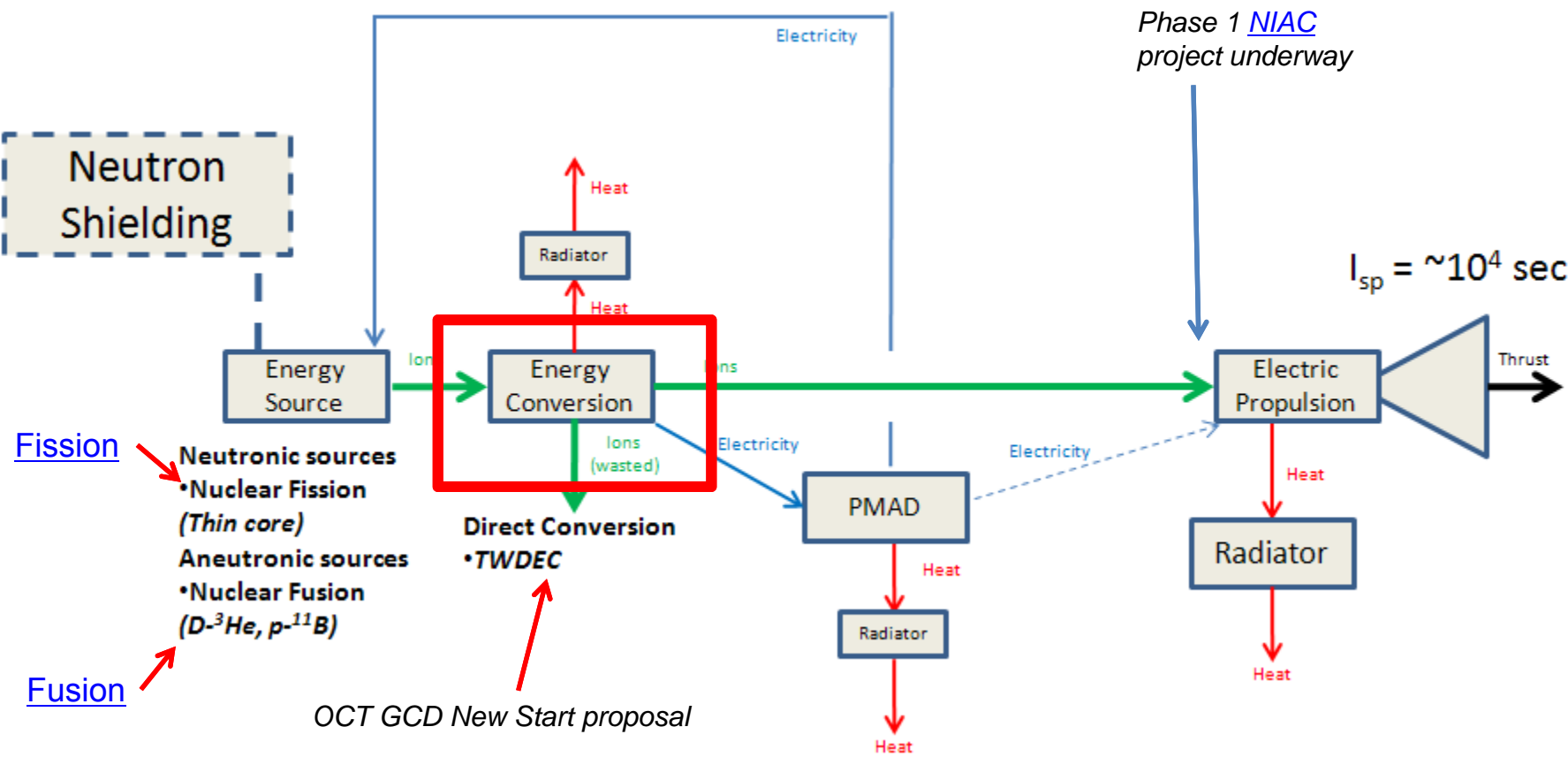

Direct conversion is the nexus of all the technologies necessary for a truly “game-changing” in-space propulsion and power system.



Options for Low- α Propulsion and Power Systems for Mars and Beyond (For 30 MW_e class)



NEP 5 year, 1200 K Fission Reactor with K-Rankine conversion, current PMAD, and Plasma EP

$$\alpha = 16 \text{ kg/kW}_e$$

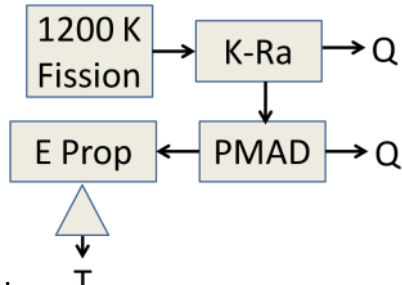

Requires Nuclear Testing for Fuel Certification and Flight Qualification

NEP 2 year, 1500 K Fission Reactor with K-Rankine conversion, advanced PMAD, and Plasma EP

$$\alpha = 10 \text{ kg/kW}_e$$

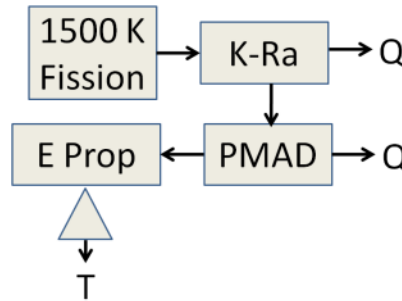

Further High Temperature Fuel Element Certification

NEP "Massless" Fission or D-T Fusion Reactor at 1500 K with K-Rankine conversion, advanced PMAD, and Plasma EP

$$\alpha = 9 \text{ kg/kW}_e$$

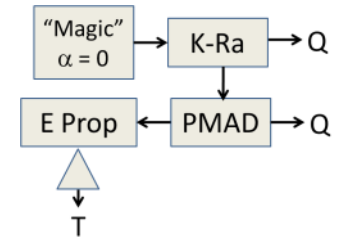

George, "Multi-Megawatt Nuclear Power Systems for Nuclear Electric Propulsion," AIAA 91-3607, 1991.

Mason et al, "Nuclear Power System Concepts for Electric Propulsion Missions to Near Earth Objects and Mars," Nuclear and Emerging Technologies for Space (NETS) Conference, Houston, TX, 2012.

No Nuclear Testing Required

Aneutronic Fusion with $T_{top} = 1500 \text{ K}$, K-Rankine Conversion, and Plasma EP

$$\alpha = 15 \text{ kg/kW}_e$$

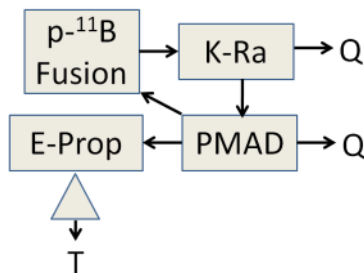

Aneutronic Fusion with TWDEC and Plasma EP

$$\alpha = 3 \text{ kg/kW}_e$$

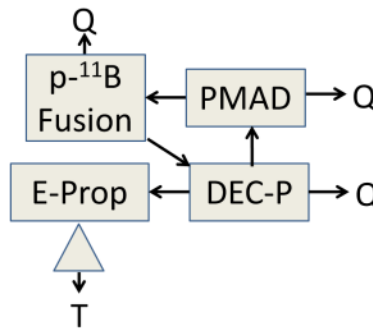

Aneutronic Fusion with TWDEC and Direct Conversion Plasma EP

$$\alpha = 1 \text{ kg/kW}_e$$

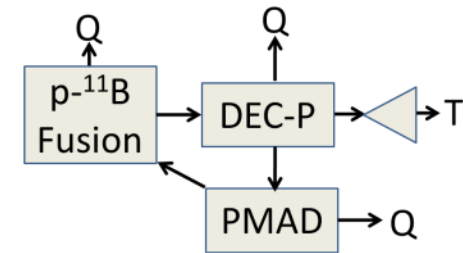



Aneutronic Fusion Power Ratio (q) Sensitivity

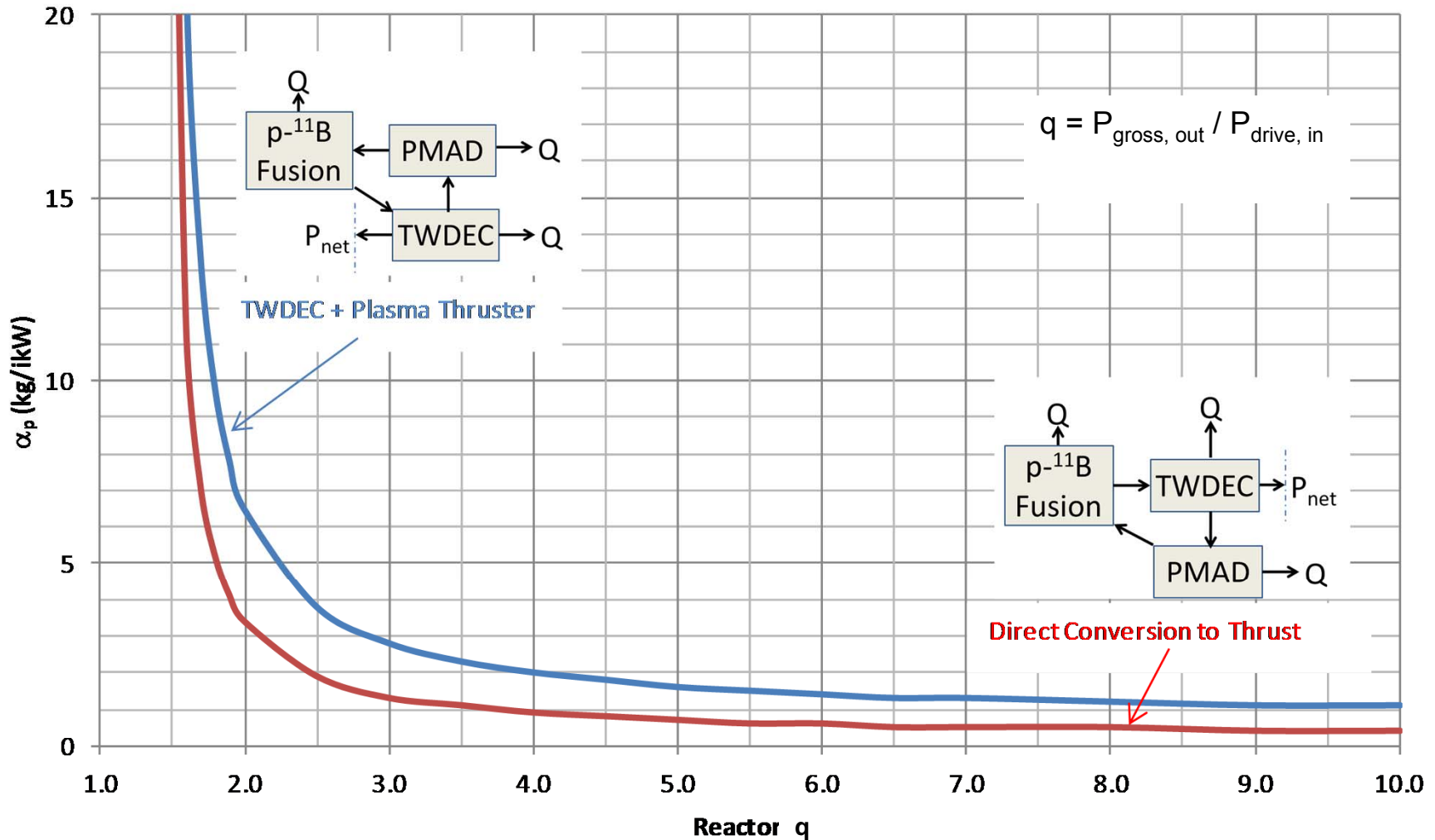

Aneutronic fusion reactors for space applications will require more aggressive q performance than those for civil power generation.



Direct Conversion Options for Ion Energy Output Literature Survey Results

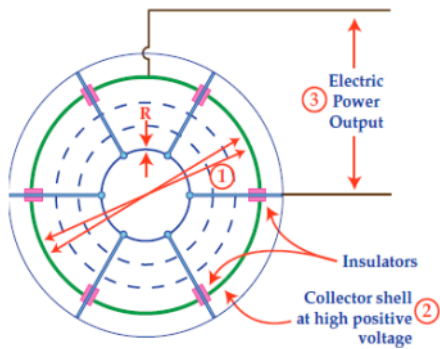

Charge Collector – TRL 1

- Conceptual design only
- Intended for “Polywell” aneutronic reactor output with MeV energies.
- DC output
- $\alpha = ?$, $\eta = ?$

Bussard, *Some Physics Considerations of Magnetic Inertial Electrostatic Confinement*, *Fusion Technology*, 1991

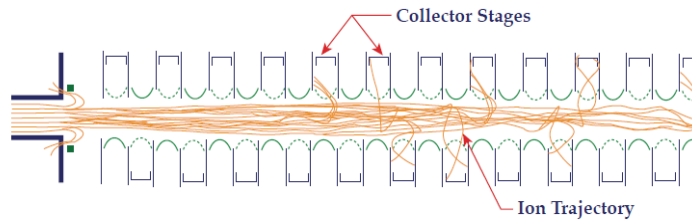

Periodic Focuser

- Preliminary design and computer modeling only
 - Intended for scavenging energy from D-T “mirror” confinement end leakage (~150 keV energies)
 - DC output
 - $\alpha = ?$, $\eta = \sim 0.6$
- Barr, Howard, and Moir (LLNL), *Computer Simulation of the Periodic Electrostatic Focusing Converter*, *IEEE Transactions on Plasma Science*, 1977

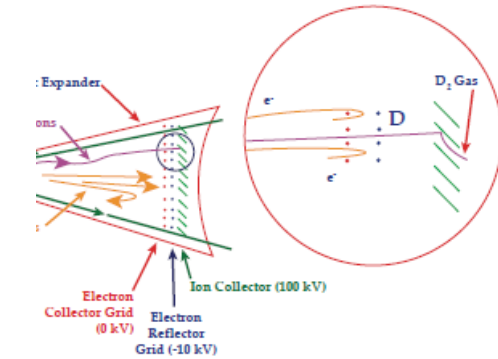

“Venetian Blind” Converter – TRL 3

- Preliminary design study and subscale testing
 - Intended for scavenging energy from D-T “mirror” confinement end leakage (~150 keV energies)
 - DC output
 - $\alpha = ?$, $\eta = \sim 0.6$
- Barr, Moir (LLNL), *Test Results On Plasma Direct Converters*. *Nuclear Technology/Fusion*, 1983.



Traveling Wave Direct Energy Converter – TRL 3

- Preliminary design study (1991) and subscale testing (1998 - 2008)
 - Originally intended for primary power from of D-³He “pinch confinement” (~15 MeV energies); studied for space applications with IEC fusion.
 - RF output
 - $\alpha = \sim 0.14 \text{ kg/kW}_{in}$, $\eta = \sim 0.7$
- Momota (NIFS-Japan), Miley (U. of Illinois), et al, *Conceptual Design of the D-³He Reactor ARTEMIS*, *Fusion Technology*, 1992



State of the Art: The Traveling Wave Direct Energy Convertor (TWDEC)



Conceptual design of half of a conversion system for a D-³He reactor with a “venetian blind” DEC for 810 MW of thermal (keV) alpha particles and a TWDEC for 368 MW of 15 MeV protons.
 Momota, Miley et al, *Fusion Technology*, 1992.

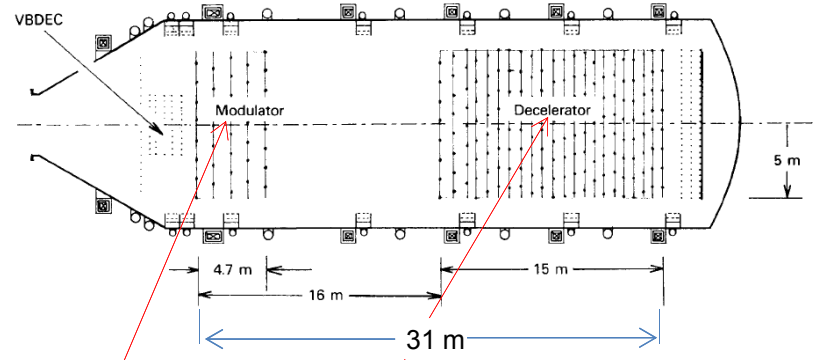

Schematic of a conversion system for a D-³He reactor for a D-³He reactor with a CUSPDEC for collection of electrons and thermal (keV) alpha particles and a TWDEC for 15 MeV protons.
 Takeno, *Proceedings of 23rd IAEA Fusion Energy Conference*, 2010.

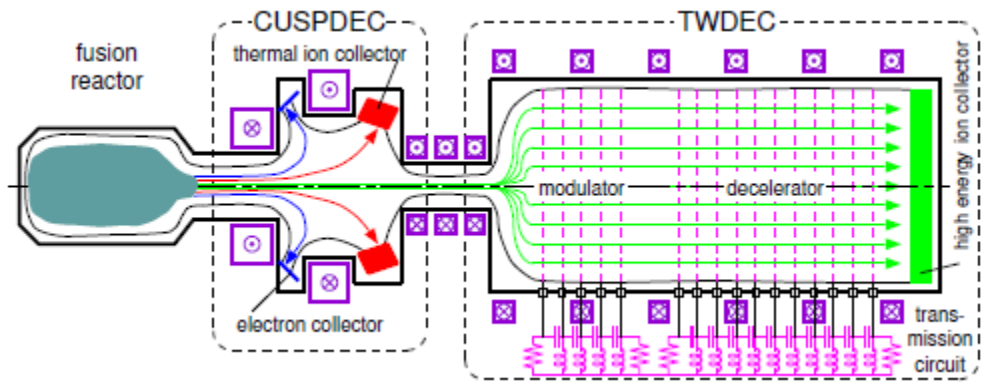

Modulator: Fusion product ions in a beam are “bunched” as they pass through evenly spaced grids of alternating potential.

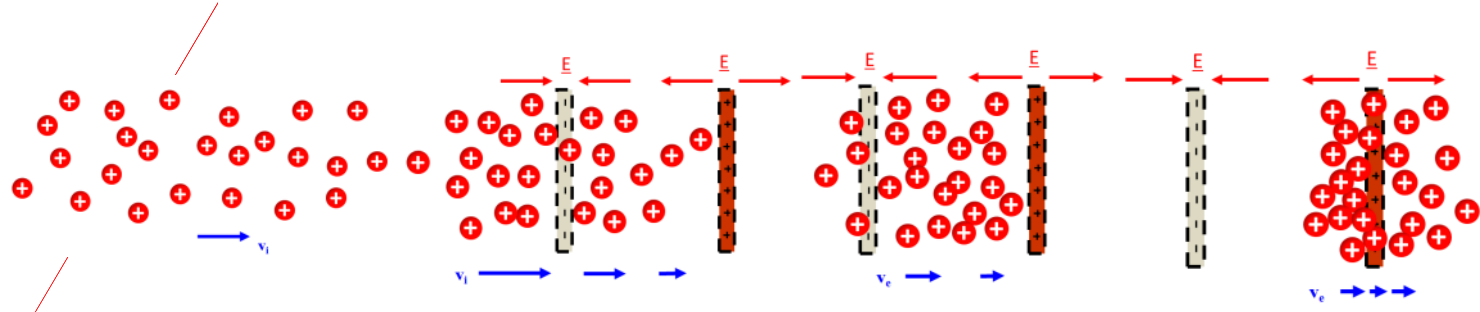

Decelerator : On each of the grids through which it passes, the ion “bunch” creates an electric potential higher than adjacent grids, which can drive an AC signal. Frequency is set by grid spacing, which decreases as the “bunches” give up energy and slow.

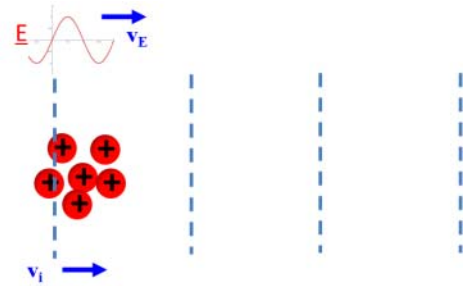

Inefficiencies come from beam thermalization, particle collisions with the grids, and residual, uncollected energy of particles downstream.

TWDEC originally conceived as direct conversion system for “ARTEMIS” D-³He, Maxwellian plasma test reactor for utility grid power.

[Momota 1992].

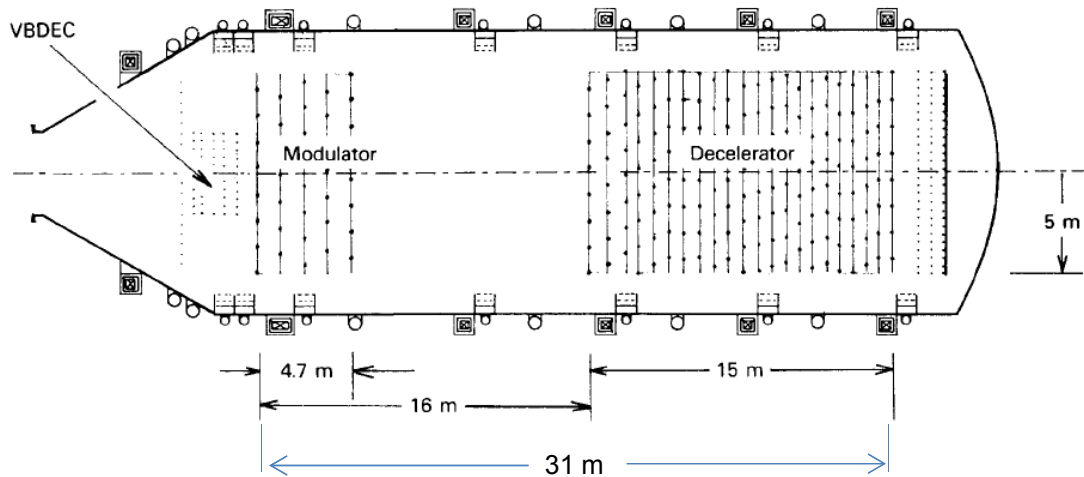

Estimated performance in ARTEMIS application

- Convert 183 MW from 14.7 MeV protons of $\rho_{\text{beam}} = \sim 10^{10} \text{ m}^{-3}$; Low ρ_{beam} requires large ($R_{\text{beam}} = 5 \text{ m}$) electrodes
- Predicted $\eta = 0.7$; electrode grid collisions rejected as heat
- Estimated α (w/o vacuum structure) = 0.14 kg/kW

Opportunities/issues with η and α for spacecraft applications

- Decreased electrode collisions** can minimize losses to be rejected as heat (e.g., replace grids with hollow electrodes)
- Increased beam density** can improve inductive coupling with electrodes and decrease electrode size (e.g., increase of ρ_{beam} to $\sim 10^{14} \text{ m}^{-3}$ with 3 MeV p-¹¹B alpha particles would enable 100 MW carried in R_{beam} of 10 cm)
- Narrowed relative thermal energy spread** can improve inductive coupling with electrodes
- Limited particle neutralization** in ion beam can improve η
- Adaptation to possible bimodal or broad spectrum alpha particle beam** from p-¹¹B fusion can improve η

a) Electrode Collision Losses

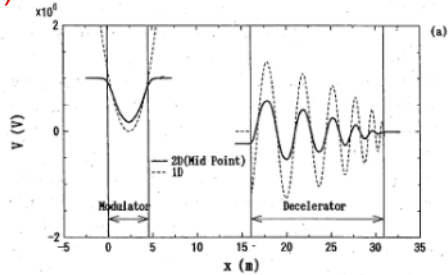

Modeling indicates 20% loss in η due to ion collisions with electrode grids [Shoyama, 1996]

b) Beam Densification

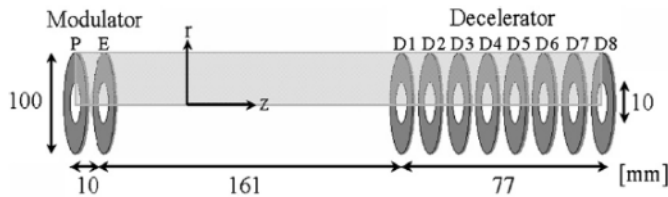

Hollow electrode experiments with keV beams indicate η maintained with $\rho_{\text{beam}} \approx 10^{12} \text{ m}^{-3}$ [Kawana, 2008]

c) Thermal Spread Mitigation

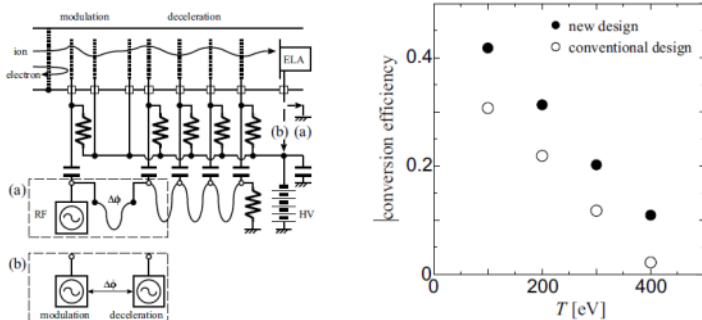

Experiments with keV beams indicate beam acceleration in modulator can decrease relative thermal energy spread and increase η [Takeno, 2011a, 2010a]

d) Mitigation of Ion Neutralization and Electron Leakage

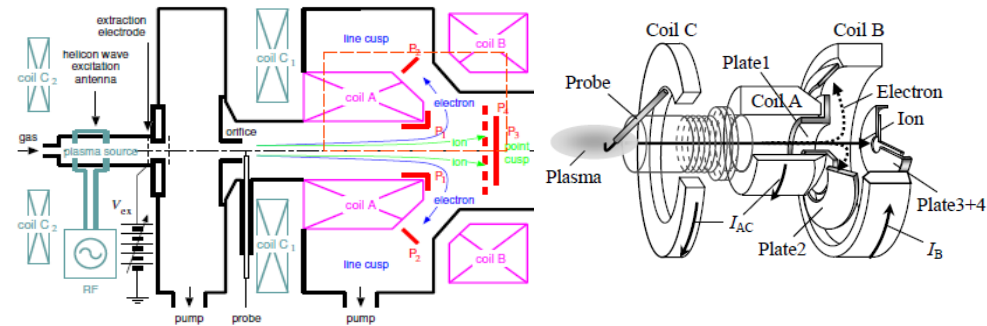

Experiments with keV beams indicate improvement in η due electron deflection in Cusp-type beam preconditioning and with electrode negative bias [Takeno 2010a, 2010b, 2011a; Taniguchi 2010]

e) Harnessing Broad Spectrum or Bimodal Beams

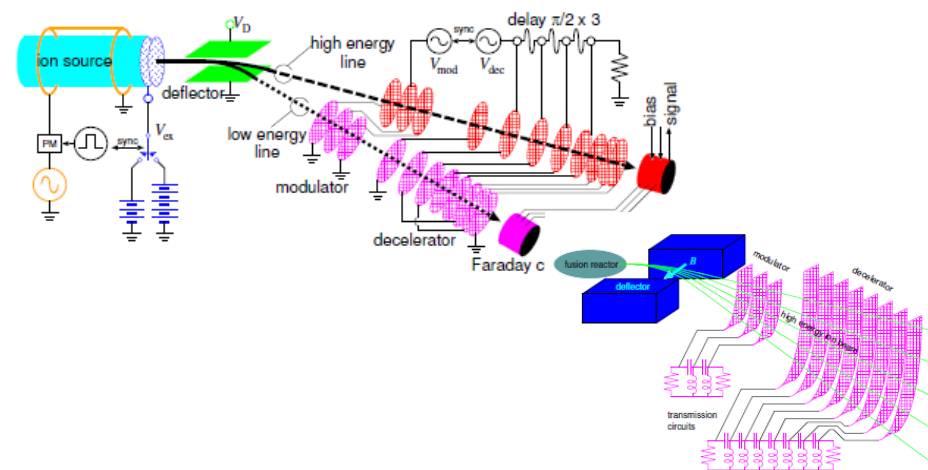

Modeling indicates that dual-beam or "fan" TWDECs can efficiently harness potentially non-mono-energetic ion beams from p-¹¹B reactors. [Takeno 2010a, 2010b, 2011a; Stave 2011]



Proposed NASA TWDEC Experiment Facility



Phase 1 NASA test article will enable further model validation of TWDEC α and η improvements with keV alpha particles of ρ_{beam} up to 10^{15} m^{-3} and with variable electrode biases and geometries.

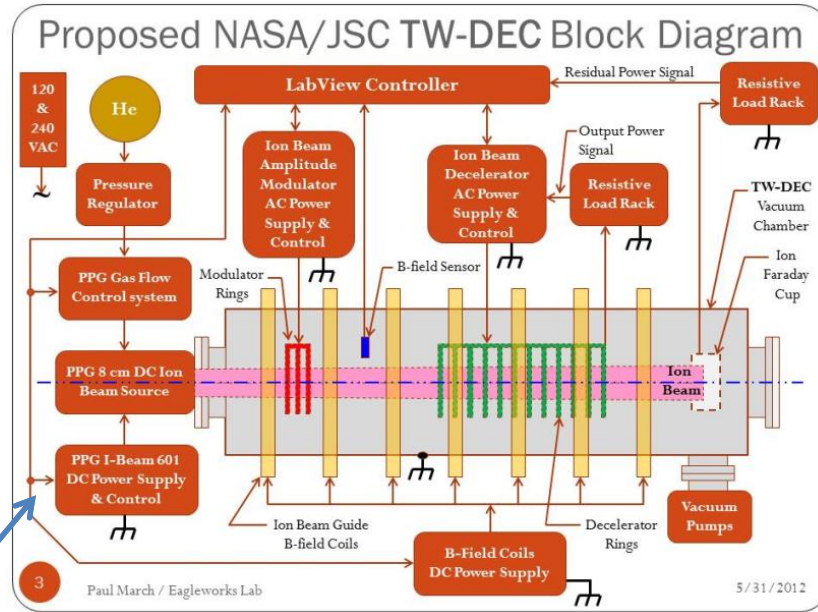
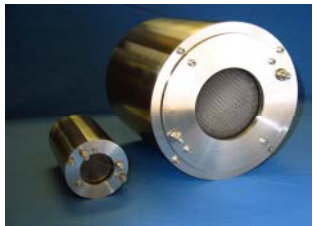

All major components will be in place by FY12end.

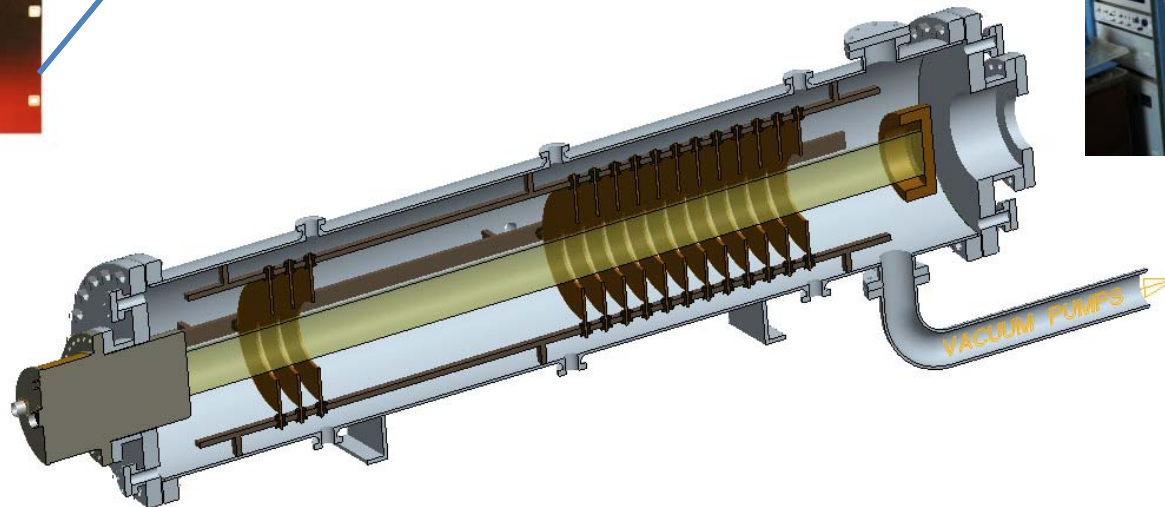
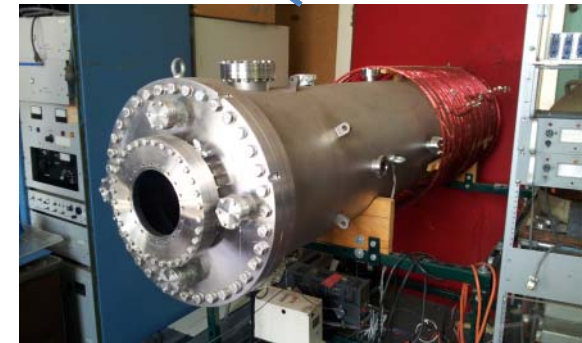



DEC Project Cost, Schedule, Deliverables & Key Milestones (Overview)



	FY13				FY14				FY 15-16 option				
	Q1	Q2	Q3	Q4	Q1	Q2	Q3	Q4	Q1/2	Q3/4	Q1/2	Q3/4	
Go/ No-Go Gates					◆ TWDEC keV High Density Hollow Electrode Simulation & Test Report				◆ TWDEC keV Simulation & Test Final Report				◆ TWDEC spacecraft TRL 4/5 Assessment
TWDEC Simulation & Testing					◆ KDP-TWDEC spacecraft viability				◆ KDP-MEV test article procurement go ahead				
		▲ TWDEC keV benchtop test article URR			▲ Complete keV test matrix baselined					▲ MeV test article assembly complete			
		▲ Initial keV simulations complete and test matrix baselined				▲ Final keV test matrix complete				▲ Initial MeV simulations complete and test matrix baselined			
		▲ Initial test matrix complete						▲ MeV test article design complete			▲ Final MeV test matrix complete		
Project Management and Partnership Development					▲ Annual Ion Energy Source Partnership Option Report				▲ FY16 Mission Architecture Study Complete				
	▲ US/Japan IEC Workshop				▲ Annual US/Japan & NIAC TWDEC Partnership Report								



Backup





Direct Energy Conversion to Thrust

NIAC Phase I



Fast ion “bunches” exhausting from a TWDEC may be able to be used to accelerate and heat slow plasma bunches created from inert gas propellant, thus lowering I_{sp} from 10^6 sec to 10^3 sec and thereby increasing thrust.

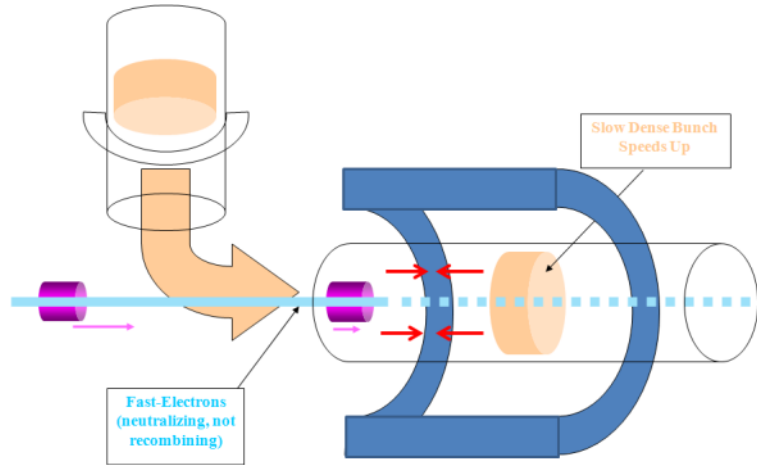

STEP 1. Injecting the alpha's with a large angle w.r.t. the axis of a solenoidal magnetic field: the longitudinal speed will be reduced and particles follow a spiral orbit

The gyro radius for a 2.9 MeV α -particle in a 1 T field is about 0.25 m.

Bunching can provide the non-adiabatic injection required to capture the ions.

STEP 2. With a collimated pencil-beam the injected bunch turns in to a hollow cylindrical layer with current density j

STEP 3. As more particles are collected the current in the layer increases that, in turn, increases the magnetic field

STEP 4. Higher current density produces “magnetic piston effect”

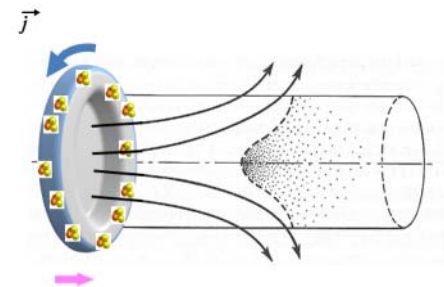
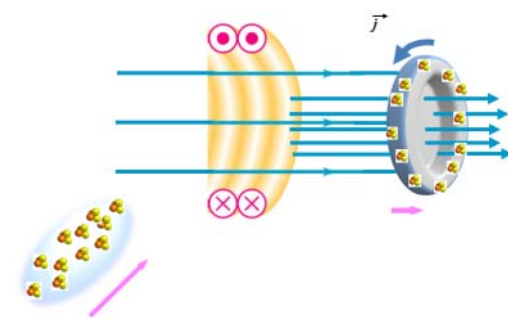
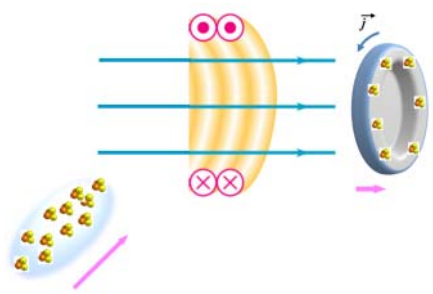
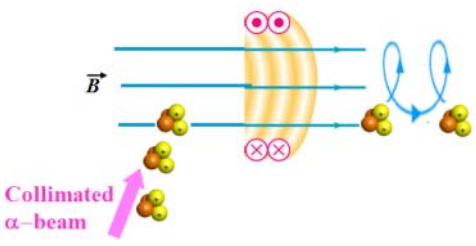



Fission DEC-to-Power Research to Date



- Concept actively studied 1957-late 1960's.
- Studies restarted under DOE "Nuclear Energy Research Initiative" in early 2000's.
 - Energy conversion by means of high voltage DC electrodes.
 - For terrestrial power: Offers higher efficiency conversion and spent fuel burn-up.

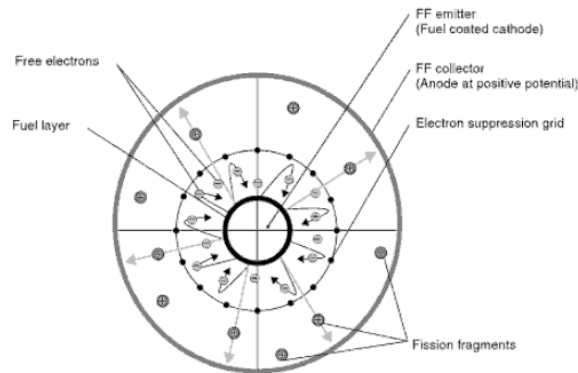
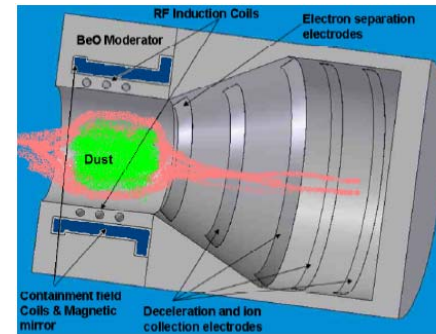

Figure 47.4 "Triode" FEC design.



R. Clark and R. Sheldon, *AIAA* 2005-4460 (2005)

P. V. Tsvetkov, *et al.*, *Trans. American Nucl. Soc.*, 91, 927 (2004)

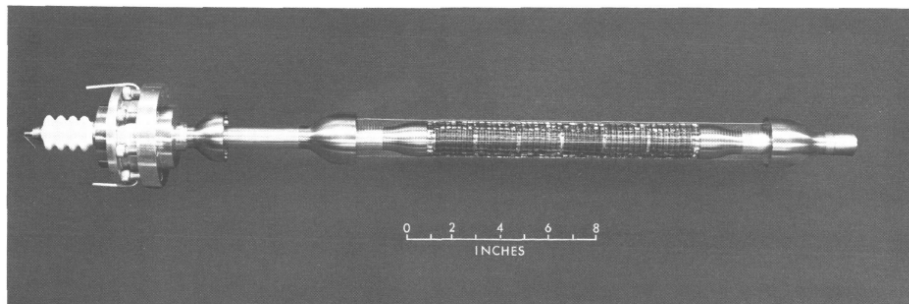

Fig. 1. Cathode assembly of original cell

C. J. Heind, "Efficiency of fission electric cells," JPL Technical Report No. 32-105, 1961

TABLE 47.1 Distribution of the Released Nuclear Fission Energy for Fission of U235

Component of Energy Release in Fission	Energy (MeV)	Fraction (%)
• Kinetic Energy of FFs	168	81.16
• Kinetic Energy of Fission Neutrons	5	2.42
• Energy of Prompt γ -Rays	7	3.38
• Total Energy of β -Particles	8	3.86
• Energy of Delayed γ -Rays	7	3.38
• Energy of Neutrinos	12	5.80
• Total Energy Release per Nuclear Fission Event	207	100.00

- Solenoidal magnetic field $B_0 = 0.5 T$:
 - ^{140}Xe fragment gyroradius = $1.71 m$

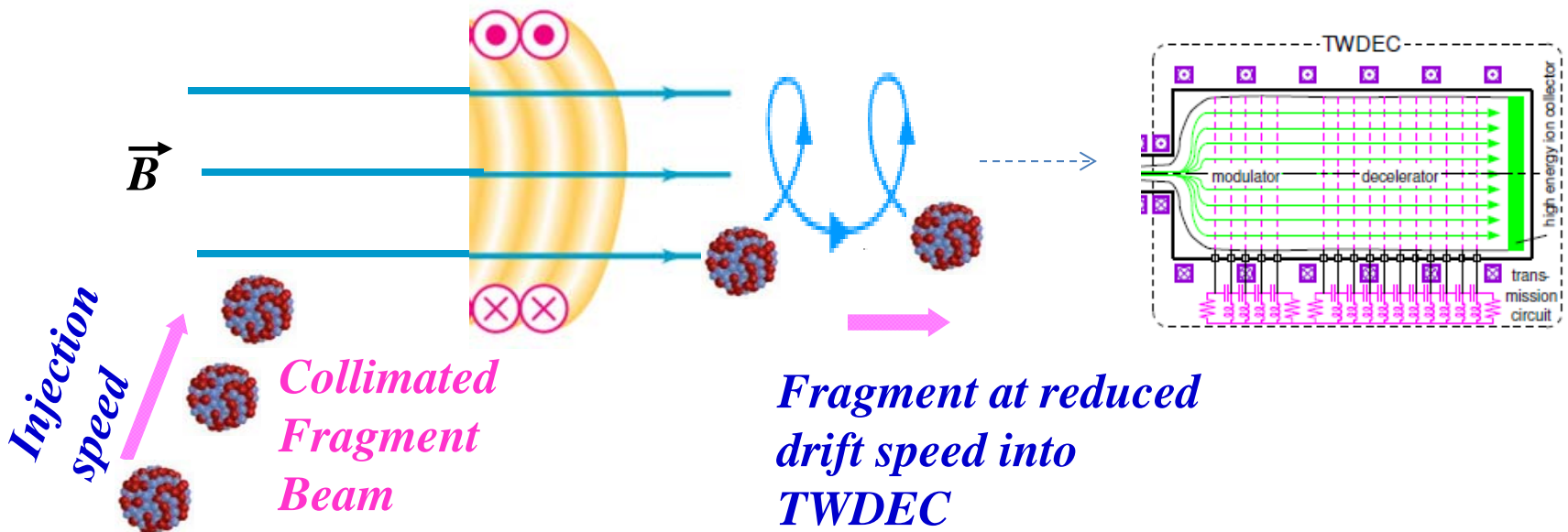

- Side injection can reduce drift speed and TWDEC frequency
- Bunching can provide the non-adiabatic injection required to capture the ions.



Fusion Fundamentals



Fusion Fuel Pairs (Product Energy)

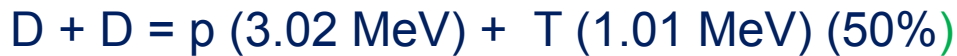

Fusion reactions can occur in **both** high temperature, thermalized plasmas and low temperature, monoenergetic colliding beams.

Fusion Reaction Cross-Sections

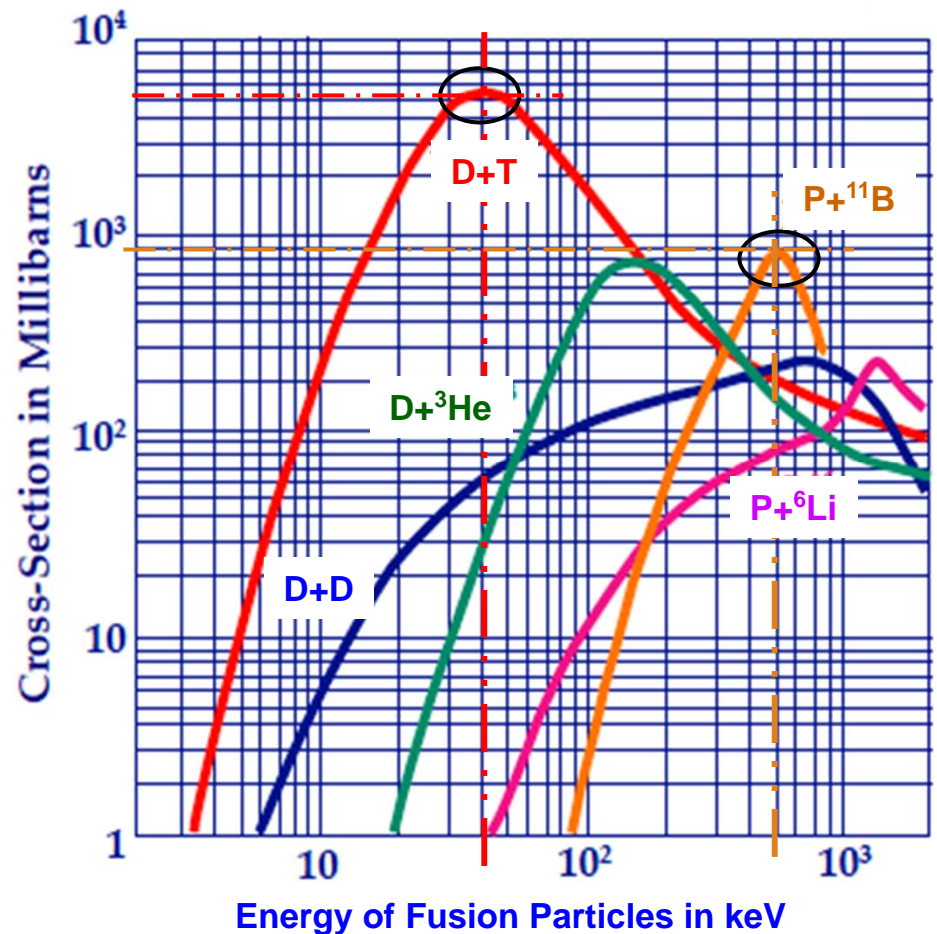



Fusion Plasma Confinement Trade Space



Plasma Energy Distribution

Maxwellian Thermal Equilibrium

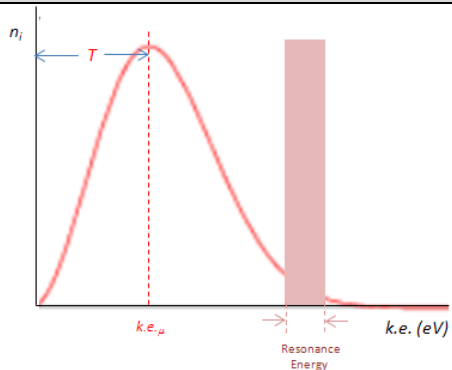

Non-Maxwellian Non-Equilibrium (Monoenergetic)

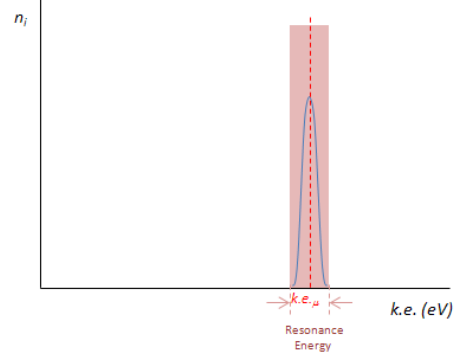

Required confinement for maintenance of aneutronic reactions

Magnetic Confinement (e.g., "Tokamak", Mirror, FRC, Z-Pinch)

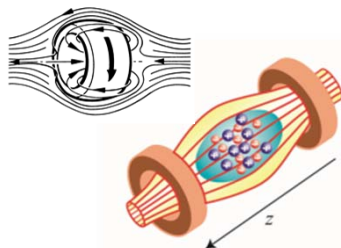
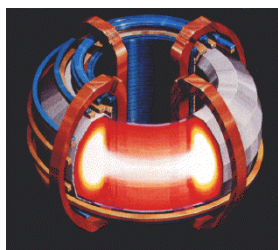

Magnetic Conf.: Field-Reversed Configuration (FRC)

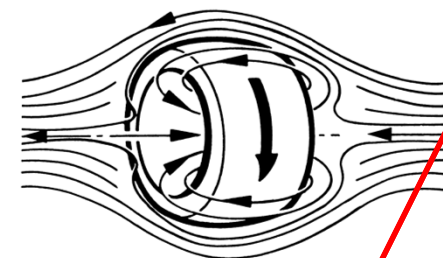
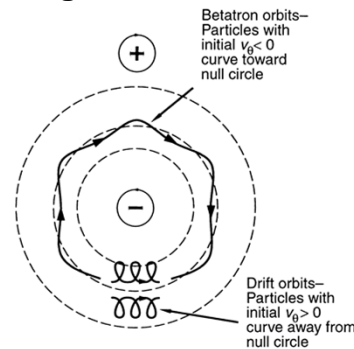

Magneto/Laser/Mechanical Inertial Confinement (e.g., National Ignition Facility)

Magnetized Target Fusion

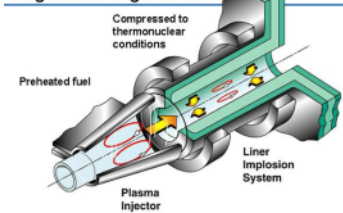

Inertial Electrostatic Confinement

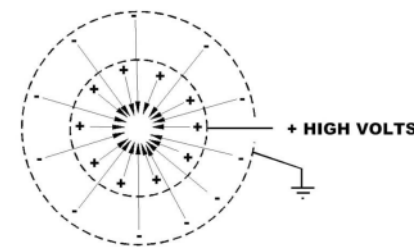
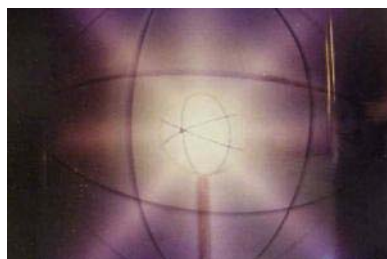



Key Papers in Fission Product Direct Conversion



S. A. Slutz *et al.*, *Phys. Plasmas* 10, 2983 (2003)

P. V. Tsvetkov, *et al.*, *Trans. American Nucl. Soc.*, 91, 927 (2004)

<http://www.ne.doe.gov>: 2003 and 2004 annual reports

R. Clark and R. Sheldon, *AIAA* 2005-4460 (2005)

G. Chapline and Y. Matsuda, *Fusion Technology* 20, 719 (1991)

P. V. Tsvetkov, *et al.*, *AIP Conference Proceedings* 813.1, 803, (2006)



Key Papers in Aneutronic Fusion



- Dawson, J., "Advanced Fusion Reactors," in Teller, E., ed., *Fusion*, Vol. 1, Academic Press, New York, 1981.
- Bussard, R., "Some Physics Considerations of Magnetic-Inertial Electrostatic Confinement: A New Concept for Spherical Converging Flow Fusion," *Fusion Technology* **19**, March 1991
- Krall, N., "The Polywell: A Spherically Convergent Ion Focus Concept," *Fusion Technology* **22**, August 1992
- Rider, T., "Fundamental Limitations on Plasma Fusion Systems not in Thermodynamic Equilibrium," *Physics of Plasmas* **4** (4), April 1997
- Chacon, L., et al, "Energy Gain Calculations in Penning Fusion Systems Using a Bounce-Averaged Fokker–Planck Model," *Physics of Plasmas* **7** (11), November 2000
- Rostoker, N., et al, "Colliding Beam Fusion Reactors," *Journal of Fusion Energy* **22** (2), June 2003



TWDEC Development References



- [Momota, 1992] Momota, H. et al, “Conceptual Design of the D-³He Reactor ARTEMIS,” *Fusion Technology* **21**, p. 2307, 1992.
- [Kawana, 2008] Kawana, R. et al, “Performance analysis of small-scale experimental facility of TWDEC,” *Energy Conversion and Management* **49** pp. 2522–2529, 2008.
- [Shoyama, 1996] Shoyama, H., et al, “Two-Dimensional Analysis of Energy Conversion Efficiency for a Traveling Wave Direct Energy Converter,” *J. Plasma Fusion Research* **72**(5), p. 439, 1996.
- [Stave, 2011] Stave, S., et al, “Understanding the $^{11}\text{B}(p,\alpha)\alpha$ reaction at the 0.675 MeV resonance,” *Physics Letters B* **696**, pp. 26-9, 2011.
- [Takeno, 2011a] Takeno, H. et al, “Analytical Experiments Using a Bias-Type Traveling Wave Direct Energy Converter Simulator Installed on Gamma 10 Tandem Mirror,” *Fusion Science and Technology* **61** (1T: Proc. 15th Int. Conf. on Emerging Nuclear Energy Systems, May 15-19, 2011, San Francisco, CA), pp. 125-8, January 2012.
- [Takeno, 2011b] Takeno, H. et al, “Studies on Modulation Process of Traveling Wave Direct Energy Converter for Advanced Fusion,” *Fusion Science and Technology* **61** (1T: Proc. 15th Int. Conf. on Emerging Nuclear Energy Systems, May 15-19, 2011, San Francisco, CA), pp. 129-33, January 2012.
- [Takeno 2010a] Takeno, H. et al, “Application of TWDEC Simulator to End-loss Flux of GAMMA 10 Tandem Mirror,” *J. Plasma Fusion Research SERIES* **9**, p. 202, 2010.
- [Takeno 2010b] Takeno, H. et al, “Improvement of Cusp Type and Traveling Wave Type Plasma Direct Energy Converters Applicable to Advanced Fusion Reactor,” *23rd IAEA Fusion Energy Conference*, Paper ICC/P7-02, 2010.
- [Taniguchi, 2010] Taniguchi, A., “Studies of Charge Separation Characteristics for Higher Density Plasma in a Direct Energy Converter Using Slanted Cusp Magnetic Field,” *J. Plasma Fusion Research SERIES* **9**, p. 237, 2010.



First Order Heat Balance and Specific Mass @ 30 MW_e: 5-year, 1200 K Fission Reactor with K-Rankine Conversion, Standard PMAD, and Plasma EP

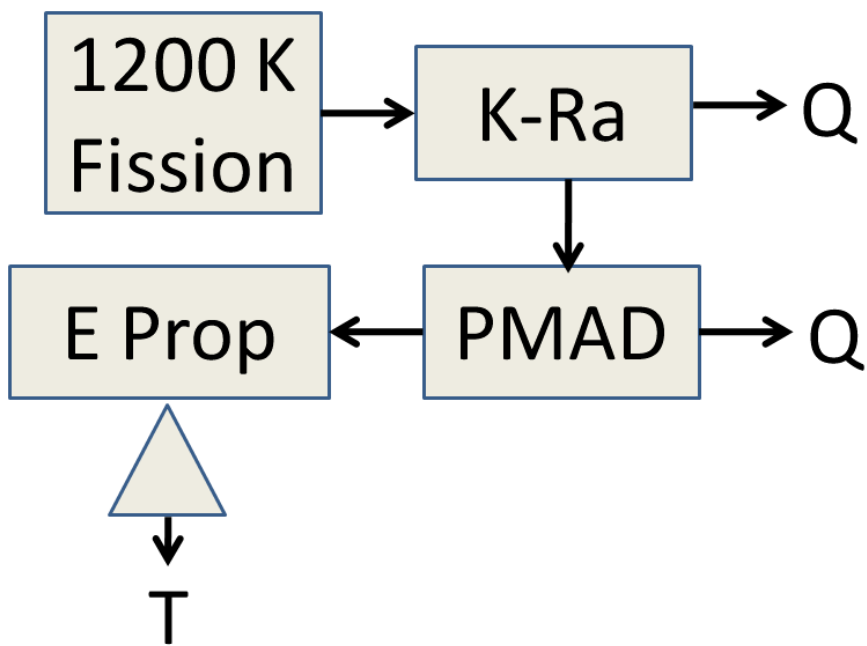

Subsystem					MW	MT
1200 K Fission Reactor (MW _{t,out})	$\alpha = 0.54$				144	78
Fission Shadow Shield (frac. MW _{t,in})	$\alpha = 1.00$				144	145
K-Rankine Heat Engine Conv. (MW _{t,in})	$\alpha = 0.50$	$\eta_c = 0.21$			144	73
800 K, 5.5 kg/m ² 1-sided Radiators (MW _{t,in})	$\alpha = 0.43$				114	49
PMAD (MW _{e,in})	$\alpha = 3.72$	$\eta_p = 0.99$			30	113
600 K, 4.5 g/m ² PMAD Radiators (MW _{t,in})	$\alpha = 0.91$				0	0
Net Power (MW _{e,out}); Total Mass (MT)					30	457
Power α (MT/MW_{e,out})					15.2	
Plasma EP Thruster (MW _{e,in})		$\eta_t = 0.60$			30	30
Plasma EP Thruster (MW _{p,out})					18	
Power & Prop Combined α (MT/MW_{e,in})					16.2	



First Order Heat Balance and Specific Mass @ 30 MW_e: 2 year, 1500 K Fission Reactor with K-Rankine conversion, Advanced PMAD, and Plasma EP

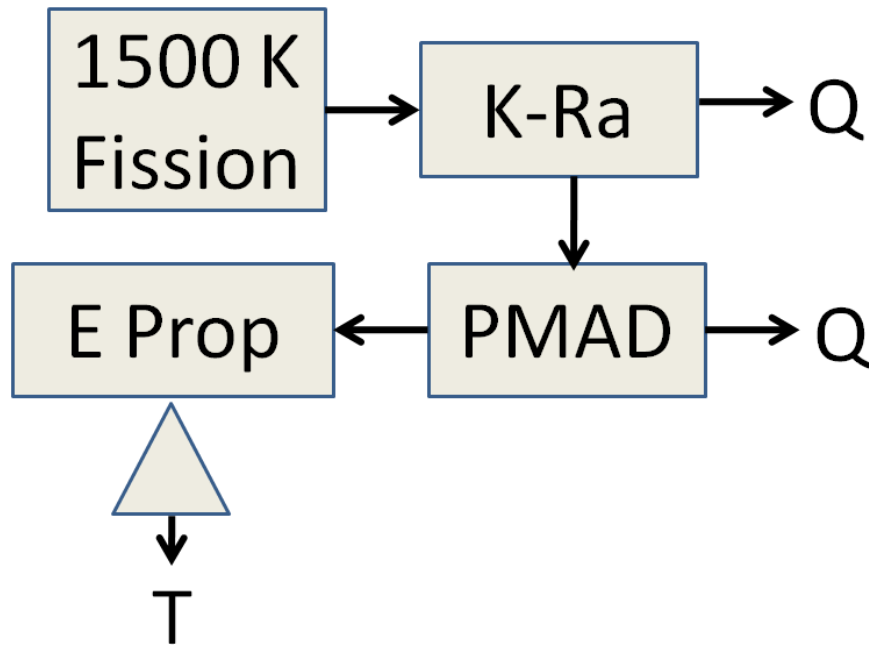

Subsystem			MW	MT
1500 K Fission Reactor (MW _{t,out})	$\alpha = 0.15$		168	26
Fission Shadow Shield (frac. MW _{t,in})	$\alpha = 1.00$		168	169
K-Rankine Heat Engine Conv. (MW _{t,in})	$\alpha = 0.14$	$\eta_c = 0.18$	168	23
1100 K, 5 kg/m ² 2-sided Radiators (MW _{t,in})	$\alpha = 0.12$		138	16
PMAD (MW _{e,in})	$\alpha = 1.00$	$\eta_p = 0.99$	30	30
600 K, 4.5 g/m ² PMAD Radiators (MW _{t,in})	$\alpha = 0.98$		0	0
Net Power (MW _{e,out}); Total Mass (MT)			30	265
Power α (MT/MW_{e,out})			8.8	
Plasma EP Thruster (MW _{e,in})		$\eta_t = 0.60$	30	30
Plasma EP Thruster (MW _{p,out})			18	
Power & Prop Combined α (MT/MW_{e,in})			9.8	



First Order Heat Balance and Specific Mass @ 30 MW_e: Aneutronic Fusion with T_{top} = 1500 K, K-Rankine Conversion, Advanced PMAD, and Plasma EP

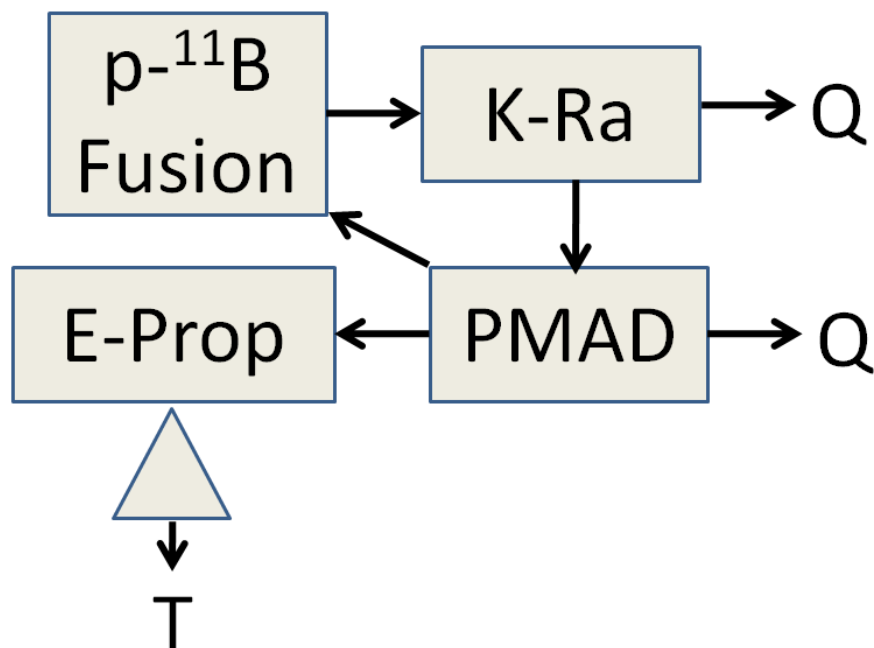

Aneutronic Fusion with T _{top} = 1500K, K-Rankine and Plasma EP (advanced)					
Subsystem				MW	MT
Fusion Reactor (MW _{t,out})	α= 0.23			379	87
Driving power (MW _{e,in})		φ _{dr} = 0.87		46	
Reactor Heat Radiators 600 K(MW _{rej})	α= 0.98	φ _{rej} = 0.00		0	0
K-Rankine Heat Engine Conv. (MW _{t,in})	α= 0.50	η _c = 0.18		424	213
1100 K, 5 kg/m ² 2-sided Radiators (MW _{t,in})	α= 0.12			348	40
PMAD (MW _{e,in})	α= 1.00	η _p = 0.99		76	76
600 K, 4.5 g/m ² PMAD Radiators (MW _{t,in})	α= 0.98			1	1
Net Power (MW _{e,out}); Total Mass (MT)				30	418
Power α (MT/MW_{e,out})				13.9	
Plasma EP Thruster (MW _{e,in})		η _t = 0.60		30	30
Plasma EP Thruster (MW _{p,out})				18	
Power & Prop Combined α (MT/MW_{e,in})				14.9	



First Order Heat Balance and Specific Mass @ 30 MW_e: Aneutronic Fusion with TWDEC, Advanced PMAD, and Plasma EP

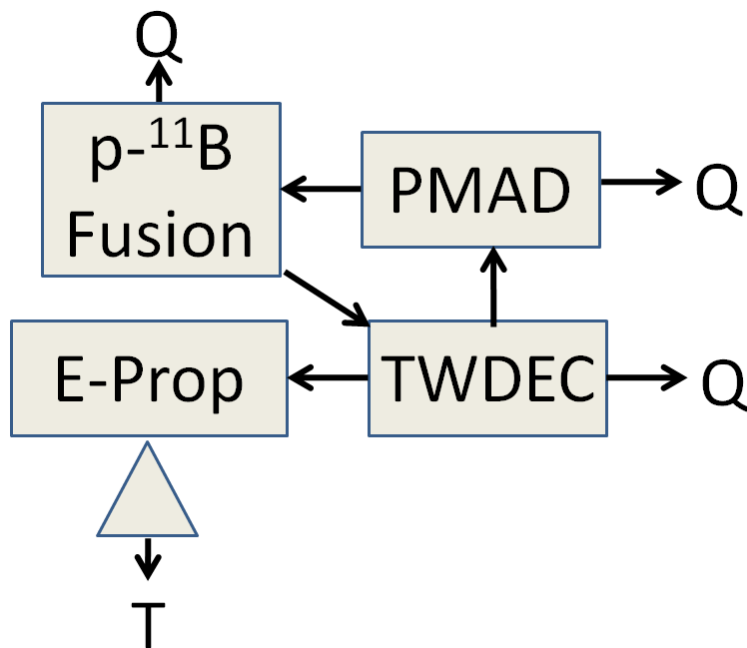

Subsystem				MW	MT
Fusion Reactor (MW _{t,out})	$\alpha = 0.20$			63	13
Driving power (MW _{e,in})		$\phi_{dr} = 0.87$		14	
Reactor Heat Radiators 600 K (MW _{rej})	$\alpha = 0.98$	$\phi_{rej,dr} = 0.57$		8	8
TWDEC (MW _{t,in})	$\alpha = 0.14$	$\eta_c = 0.70$		63	9
600 K, 4.5 g/m ² TWDEC Radiators (MW _{t,in})	$\alpha = 0.98$	$\phi_{rej,tw} = 0.50$		9	9
PMAD (MW _{e,in})	$\alpha = 1.00$	$\eta_p = 0.99$		14	14
600 K, 4.5 g/m ² PMAD Radiators (MW _{t,in})	$\alpha = 0.98$			0	0
Net Power (MW_{e,out}); Total Mass (MT)				30	52
Power α (MT/MW_{e,out})			1.7		
Plasma EP Thruster (MW _{e,in}) - VASIMR		$\eta_t = 0.60$		30	30
Plasma EP Thruster (MW _{p,out}) - VASIMR				18	
Power & Prop Combined α (MT/MW_{e,in})			2.7		



First Order Heat Balance and Specific Mass @ 30 MW_e: Aneutronic Fusion with TWDEC, Advanced PMAD, and Direct Conversion Plasma EP

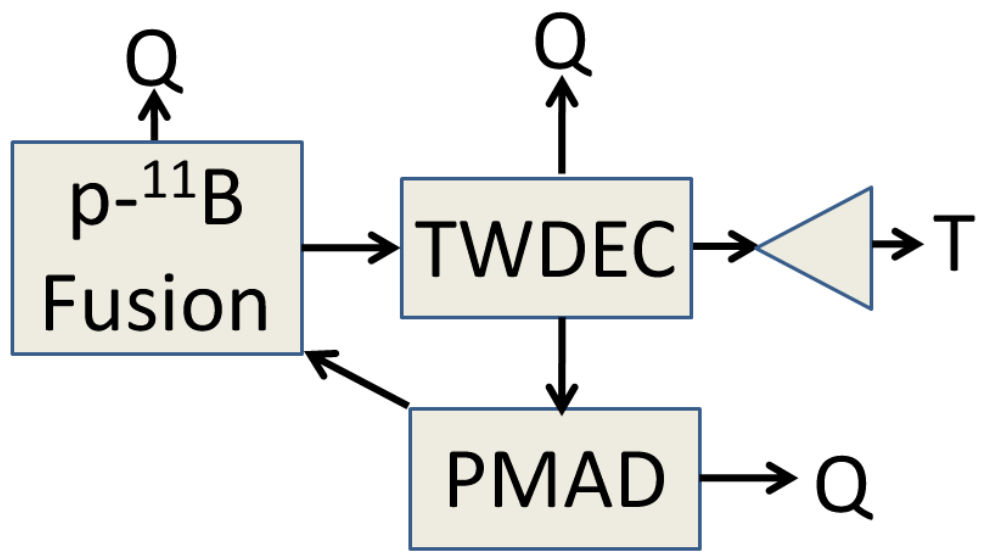

Subsystem				MW	MT
Fusion Reactor (MW _{t,out})	$\alpha = 0.20$			46	9
Driving power (MW _{e,in})			$\phi_{dr} = 0.87$	11	
Reactor Heat Radiators 600 K (MW _{rej})	$\alpha = 0.98$		$\phi_{rej} = 0.57$	6	2
TWDEC (MW _{t,in} - only for driving power)	$\alpha = 0.14$		$\eta_c = 0.70$	16	2
600 K, 4.5 g/m ² TWDEC Radiators (MW _{t,in})	$\alpha = 0.98$		$\phi_{rej,tw} = 0.50$	5	1
PMAD (MW _{e,in})	$\alpha = 1.00$		$\eta_p = 0.99$	11	11
600 K, 4.5 g/m ² PMAD Radiators (MW _{t,in})	$\alpha = 0.98$			0	0
Net Power (MW _{t,out}); Total Mass (MT)				30	26
Power α (MT/MW_{e,out})				0.9	
Direct Plasma Thruster (MW _{e,in})	$\alpha = 0.40$		$\eta_t = 0.60$	30	12
Direct Plasma Thruster (MW _{p,out})				18	
Power & Prop Combined α (MT/MW_{t,in})				1.3	



First Order Heat Balance and Specific Mass @ 30 MW_e: “ $\alpha = 0$ ” Fission or D-T Fusion Reactor with K-Rankine conversion, Advanced PMAD, and Plasma EP

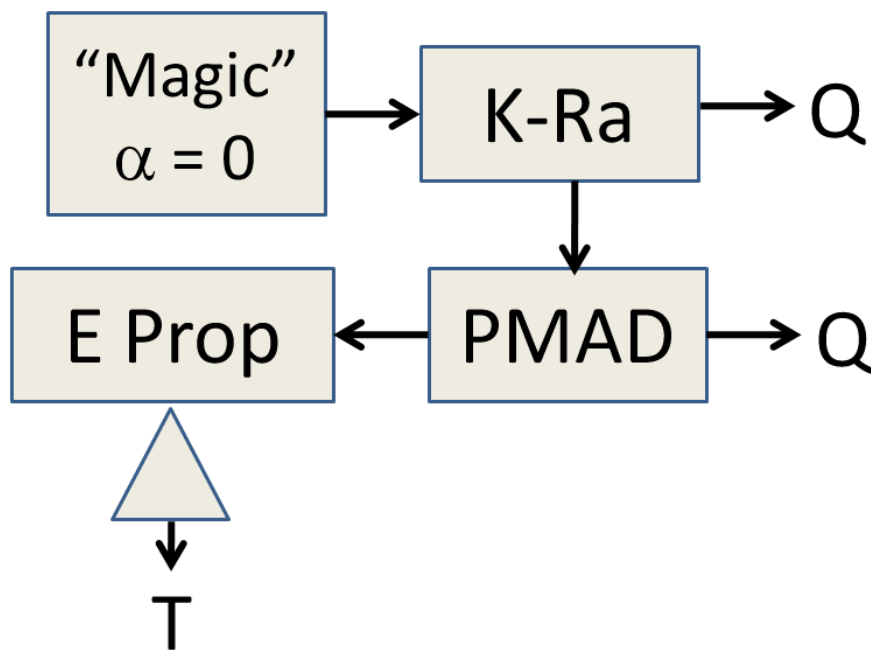

Subsystem				MW	MT
Magic Fission or D-T Fusion Reactor (MW _{t,out})	$\alpha = 0.00$			168	0
Fission Shadow Shield (frac. MW _{t,in})	$\alpha = 1.00$			168	169
K-Rankine Heat Engine Conv. (MW _{t,in})	$\alpha = 0.18$	$\eta_c = 0.18$		168	30
1100 K, 5 kg/m ² 2-sided Radiators (MW _{t,in})	$\alpha = 0.12$			138	16
PMAD (MW _{e,in})	$\alpha = 1.00$	$\eta_p = 0.99$		30	30
600 K, 4.5 g/m ² PMAD Radiators (MW _{t,in})	$\alpha = 0.98$			0	0
Net Power (MW _{e,out}); Total Mass (MT)				30	246
Power α (MT/MW_{e,out})				8.2	
Plasma EP Thruster (MW _{e,in})	$\alpha = 1.00$	$\eta_t = 0.60$		30	30
Plasma EP Thruster (MW _{p,out})				18	
Power & Prop Combined α (MT/MW_{e,in})				9.2	