

ASM AeroMat 2013,
Bellevue, Washington
April 2-5, 2013

NDT and SHM of Carbon Fiber Composites using Linear Drive MWM[®]-Arrays

3 April 2013

Andrew Washabaugh, Christopher Martin, Robert Lyons, David Grundy, Neil Goldfine
JENTEK Sensors, Inc., Waltham, MA 02453-7013
Phone: 781-642-9666; Email: jentek@jenteksensors.com

Richard Russell
NASA Kennedy Space Center
Phone: 321-861-8618; Email: richard.w.russell@nasa.gov

Russell Wincheski
NASA Langley Research Center
Phone: 757-864-4798; Email: russell.a.wincheski@nasa.gov

MWM sensors and MWM-Arrays are covered by many issued and pending patents, including (but not limited to): 8,237,433, 8,222,897, 8,050,883, 7,994,781, 7,876,094, 7,812,601, 7,696,748, 7,589,526, 7,533,575, 7,528,598, 7,526,964, 7,518,360, 7,467,057, 7,451,657, 7,451,639, 7,411,390, 7,385,392, 7,348,771, 7,289,913, 7,280,940, 7,230,421, 7,188,532, 7,183,764, 7,161,351, 7,161,350, 7,106,055, 7,095,224, 7,049,811, 6,995,557, 6,992,482, 6,952,095, 6,798,198, 6,784,662, 6,781,387, 6,727,691, 6,657,429, 6,486,673, 6,433,542, 6,420,867, 6,380,747, 6,377,039, 6,351,120, 6,198,279, 6,188,218, 6,144,206, 5,966,011, 5,793,206, 5,629,621, 5,990,677 and RE39,206 (other US/foreign patents issued and pending).



Presentation Outline

- Background
 - Development program goals
 - MWM-Array technology
 - Depth of penetration of sensing fields
 - Eddy-current extension of micromechanical model
- Example applications
 - Rotational measurements – verifying fiber orientations
 - Imaging impact damage
 - Volumetric imaging of damage
 - Stress monitoring of composites
 - Composite Overwrapped Pressure Vessel inspection and monitoring
- Summary



Development Program Approach

- **Goals**
 - Develop model-based methods for (primarily) carbon fiber composite NDT
 - Demonstrate high resolution damage and condition imaging for composites
 - Develop volumetric stress sensing magnetic stress gages for composites
- **Approach**
 - Focus on eddy current methods and sensor designs that are readily modeled.
 - MWM-Arrays uses a linear drive eddy current sensor array construct
 - Can induce eddy currents in the linear fibers of carbon fiber composites
 - In addition to using multiple frequencies, use winding geometry changes to alter penetration depth and assess material condition (e.g., damage and stress)
- **Funding**
 - NASA for micromechanical model development and application to composite overwrapped pressure vessels (COPVs)
 - Army for rotor blade NDT
 - Navy for NDT of aircraft composites

MWM-Array Technology

- Eddy current array geometry designed to match (isotropic) models for responses
- The voltage induced on sense element(s) is measured.
- Measurement grid methods provide conversion of measured responses into physical properties (e.g., conductivity, lift-off, permeability)

Magnetic field interacting with test material

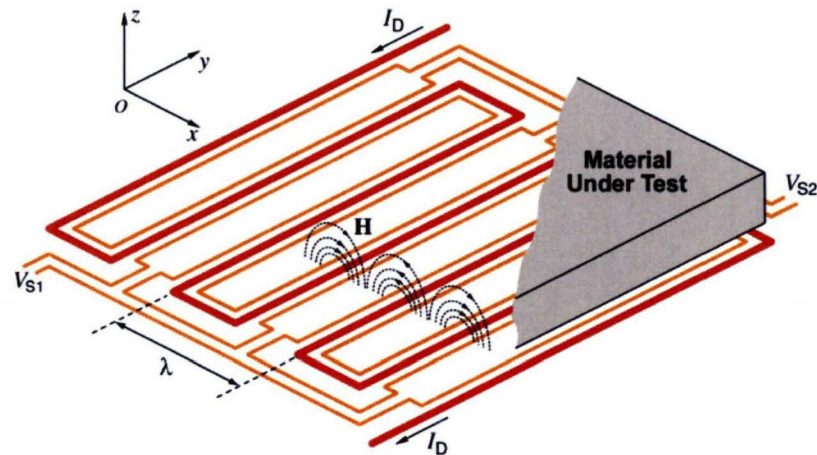

Parallel Architecture Instruments:
GS-Durable and GS-HandHeld



Example MWM-Arrays

- Array dimensions can be adjusted for the application
 - Drive-sense gap (spatial wavelength) affects penetration depth

FA28
37 elements
small wavelength

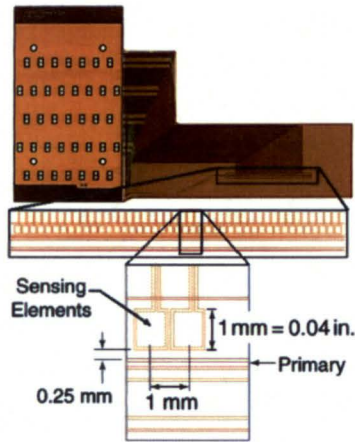

FA154
7 elements
medium wavelength

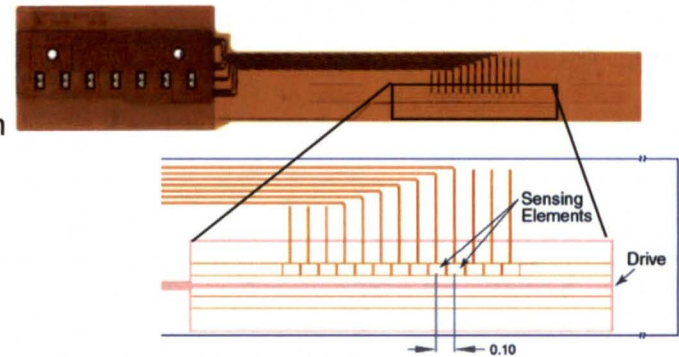

FA24
37 elements
large wavelength

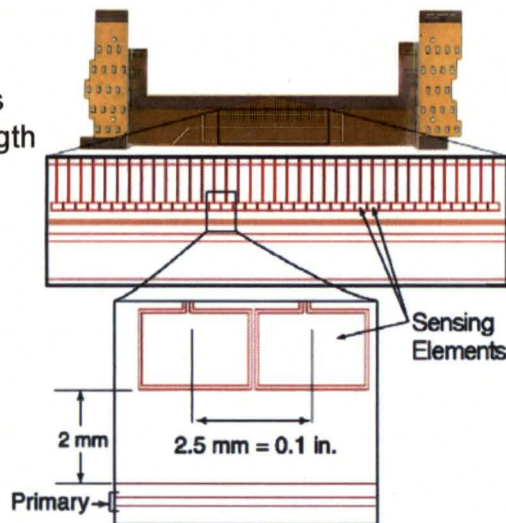

FA49
7 elements
several wavelengths

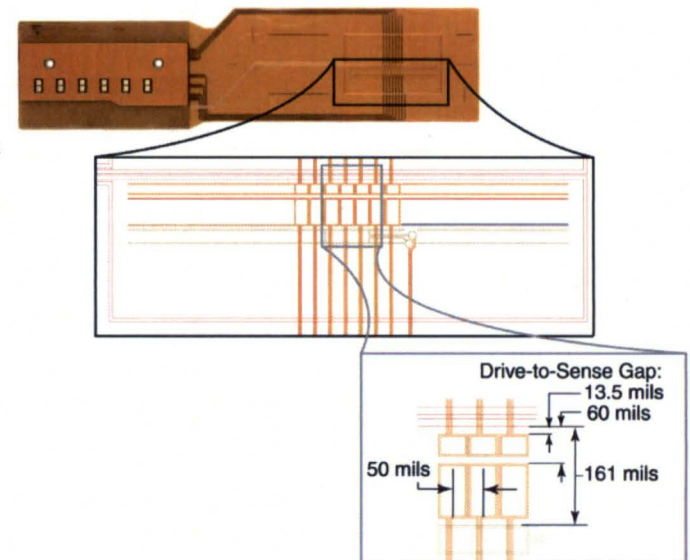

Measurement Grids for Simplified Model

MWM and MUT Model

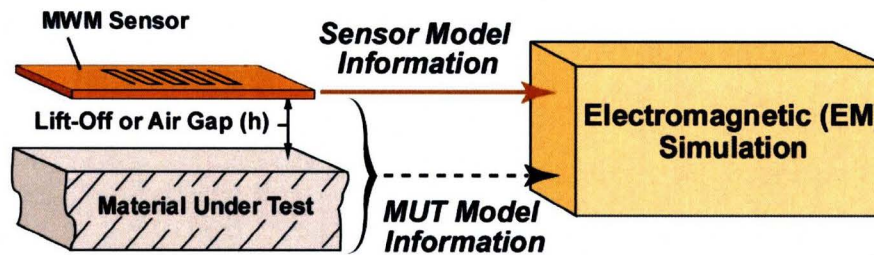

Measurement Grid

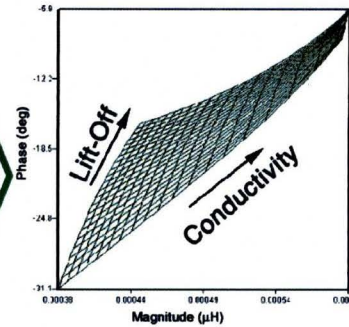

Example Grids for the MWM FS35 Sensor and Aluminum

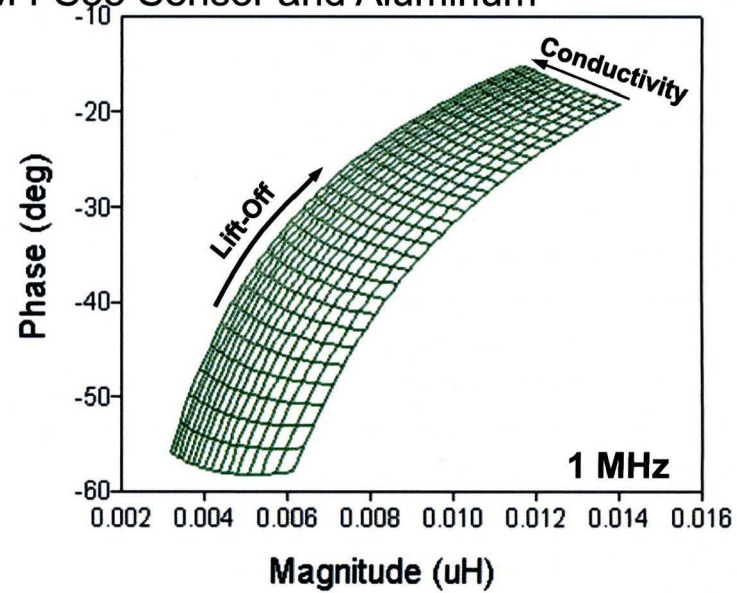
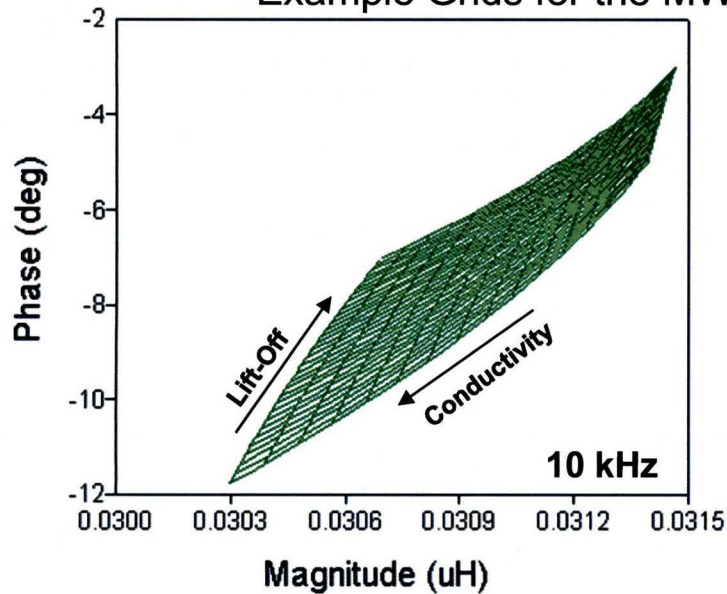

MWM-Array Depth of Penetration

- Magnetic field decays exponentially with distance away from sensor
 - Decay rate determined by skin depth at high frequencies and sensor dimensions at low frequency

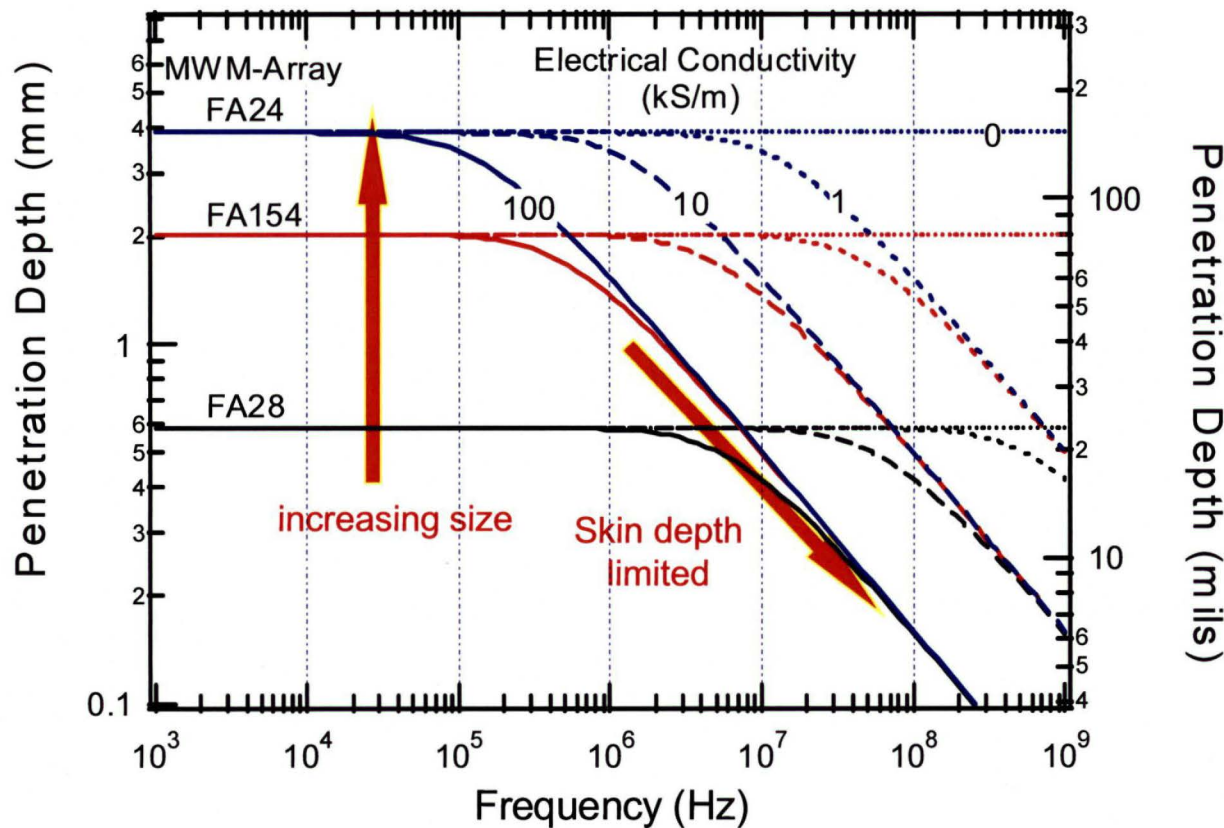

Spatial Fourier Mode Depth of Penetration = $1/\text{Re}(\Gamma_n)$

$$\Gamma_n = \sqrt{(2\pi n / \lambda)^2 + j2 / \delta^2}$$

Skin depth: $\delta = \sqrt{\frac{1}{\pi f \mu \sigma}}$

Micromechanical Model: Eddy-Current Extension

- Model considers fiber bundles as an assemblage of parallel cylinders
 - Solve for field around a single fiber and extend to fiber bundle
 - Effective complex permeability and conductivity depend upon orientation with respect to fiber axis, fiber density and fiber contact
- For carbon fiber composites
 - Graphite fibers: $\sim 7 \mu\text{m}$ diameter, nonmagnetic, $\sim 20 \text{ kS/m}$ (0.0344% IACS)
 - Radius \ll skin depth for typical eddy-current frequencies
- Indicates a strong orientation dependence of the properties
 - MWM-Arrays with linear drives can provide a measure of these orientation dependent responses

$$\mu_{par}^* \approx \mu_{perp}^* \approx \mu_0$$

$$\sigma_{perp} \approx 0$$

$$\sigma_{par} \approx \sigma_f v_f$$

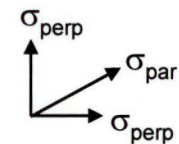
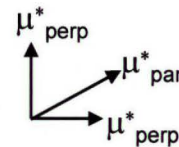
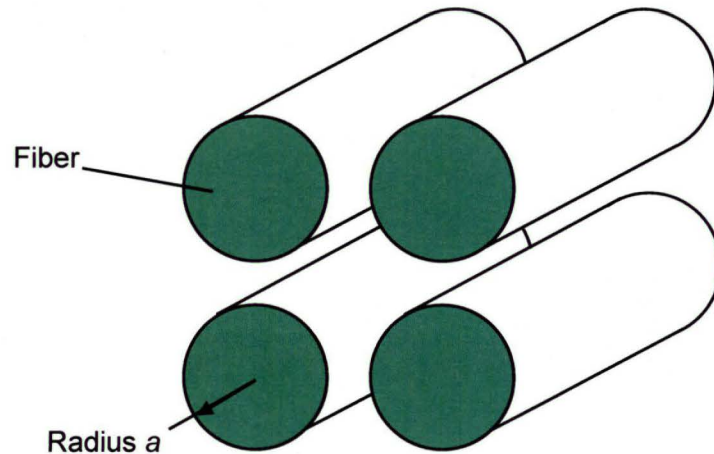

This first order model neglects interconnections (touching) between fibers

Composite Measurements: Orientation Effect

- Center element for FA28 MWM-Array
- Strong response when aligned with fibers in individual plies

Unidirectional Layup

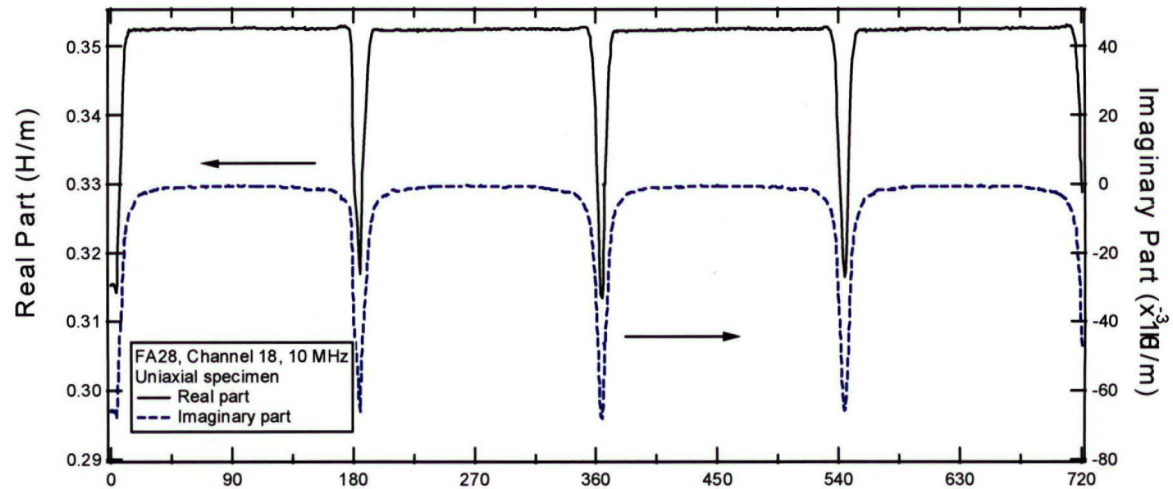

Quasi-isotropic Layup
(alternating layers at
-45°, 0°, 45°, 90°)

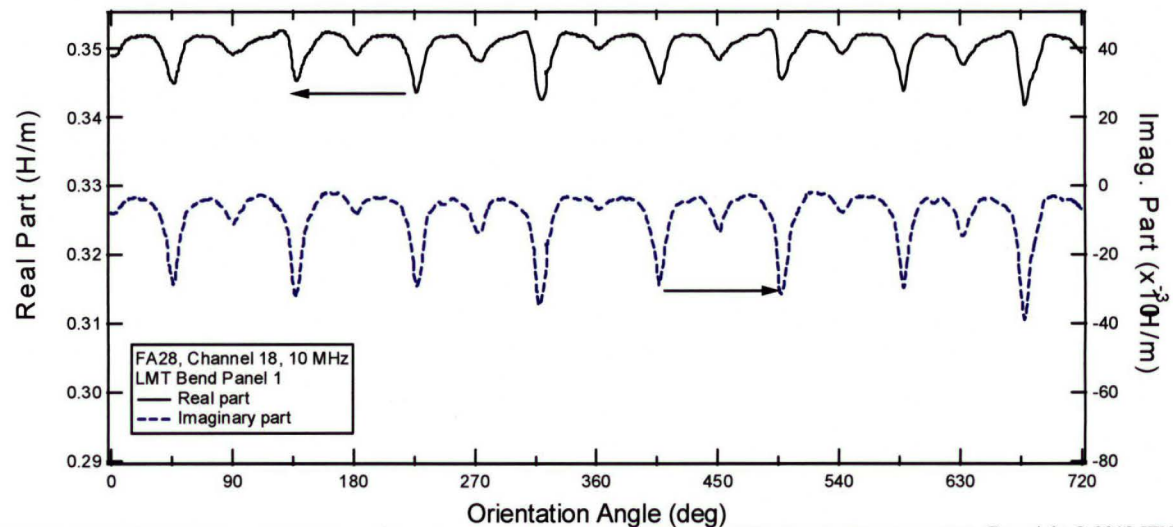

Simple layered-Media Composite Representation

- Layup for quasi-isotropic test panel
 - Uniaxial properties for each layer
- MWM-Array sensitive to composite layers with fibers oriented parallel to drive windings
- Composite layer appeared insulating if the drive windings are NOT within several degrees of fibers
- This visualization indicates that each sensor orientation is only sensitive to a subset of plies at varying depths within the composite.

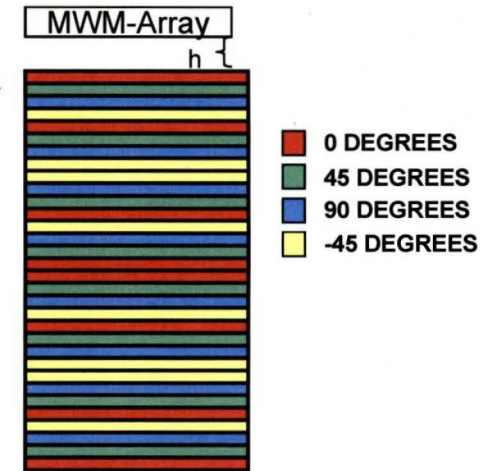

(note that the angle is relative to the fibers at the surface)

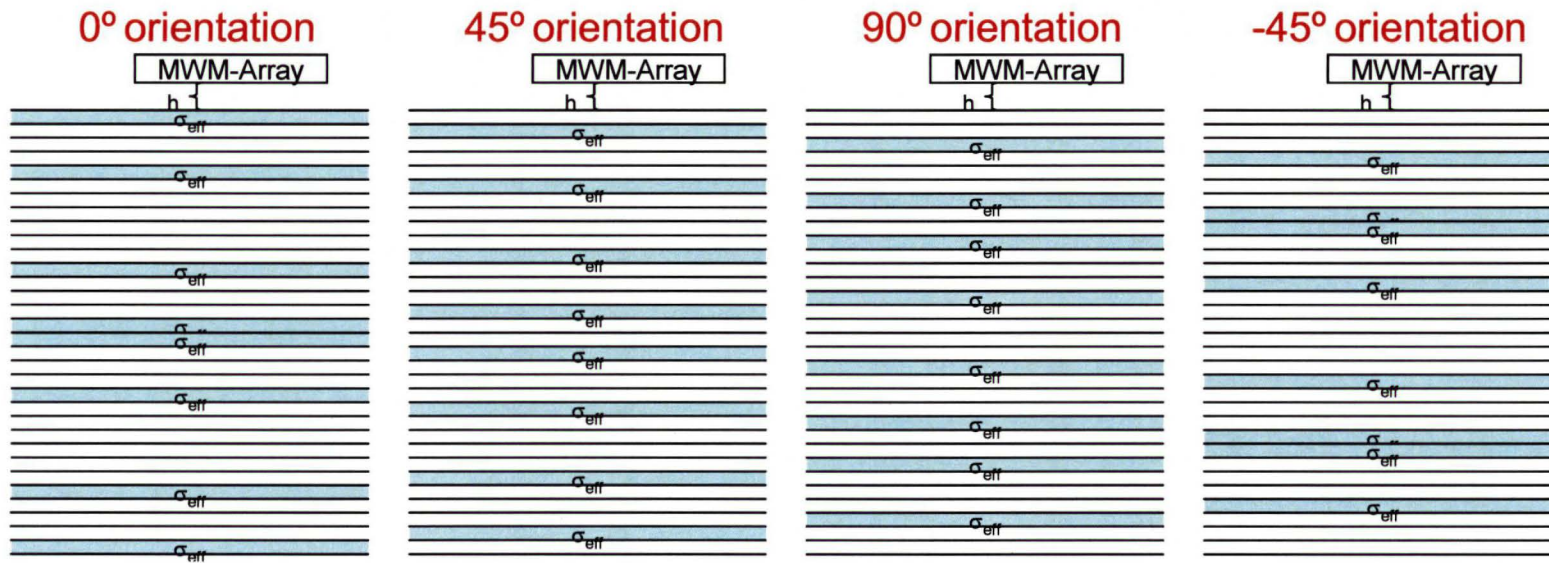

Layered-Media Composite Grid Example

- Conductivity/lift-off measurement grids assuming quasi-isotropic layup
 - Non-zero conductivity only for aligned layers in each orientation
- Primarily observe response shift as effective lift-off changes with orientation
- General agreement of the model with measurement data in each orientation
 - Data is below the grids for the deep plies (0° and 90°), so other factors need to be considered

Quasi-isotropic Layup
(note that the angle here refers to the panel orientation)

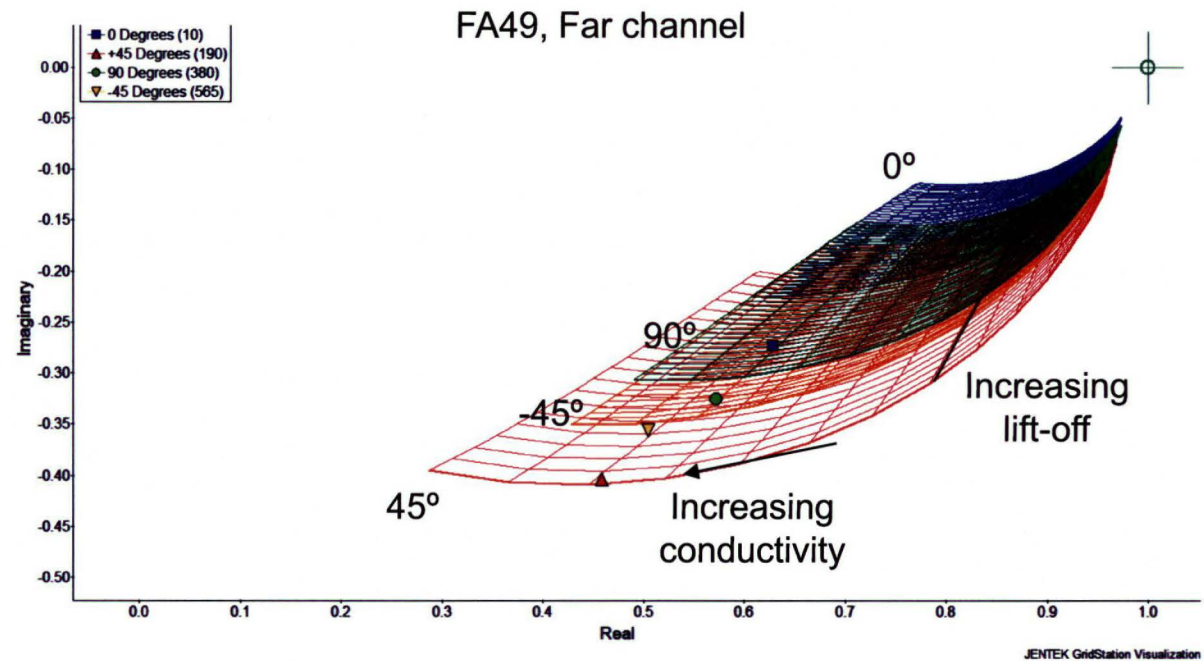
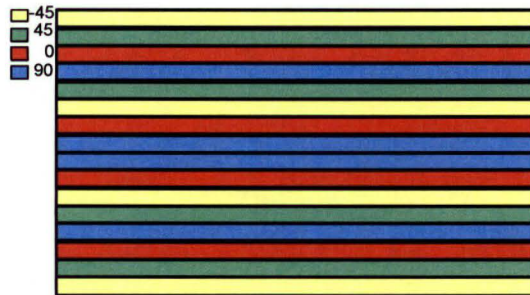

Volumetric Property Imaging Approach

- Combination of sensor orientation and geometry can isolate depth and region of damage
 - sensor orientation determines plies
 - sensor geometry determines depth of sensitivity
 - spatial extent of damage determined from scan image

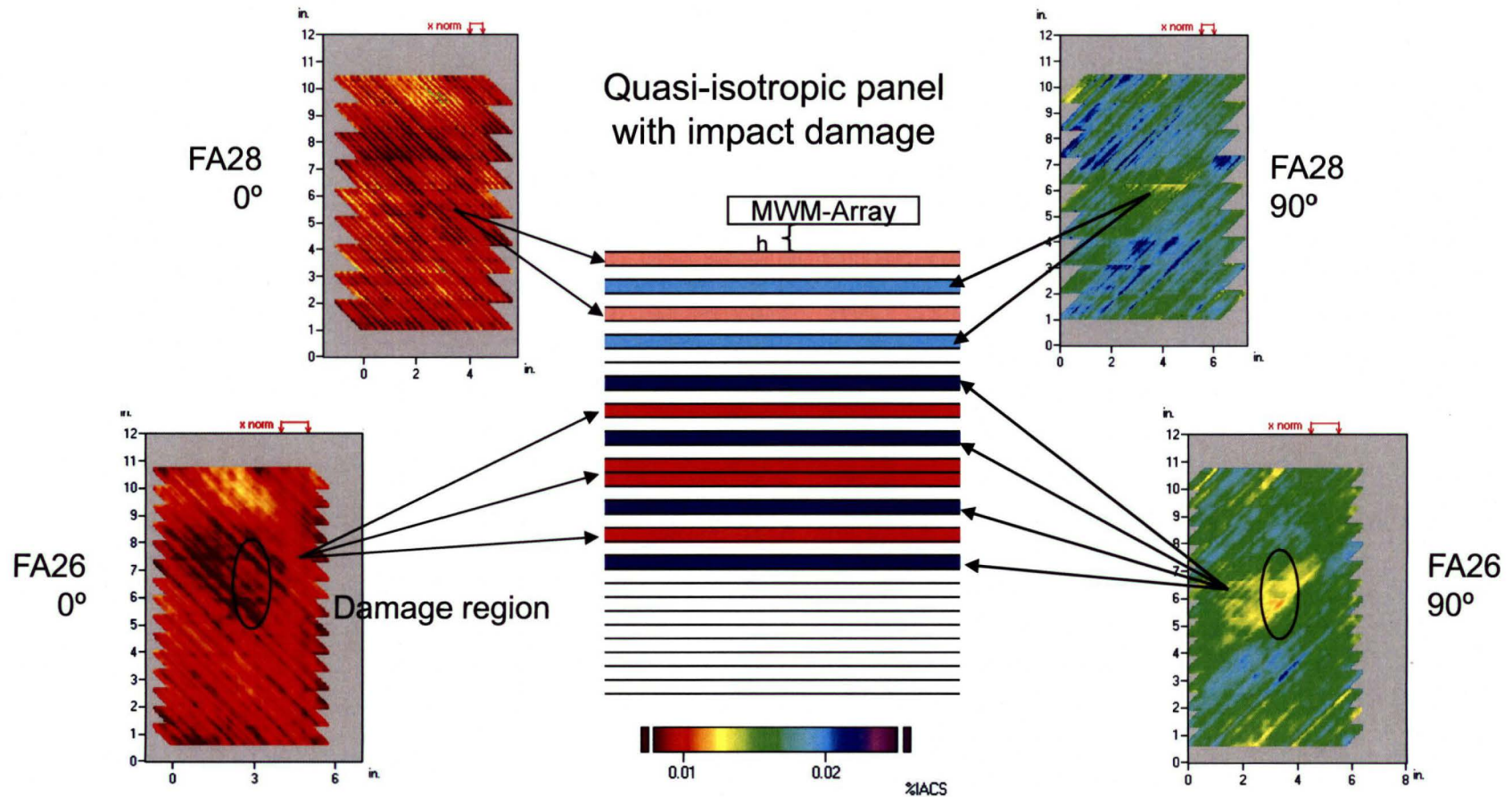

Volumetric Imaging of Composite Impact Damage

Sample provided courtesy of Lockheed Martin

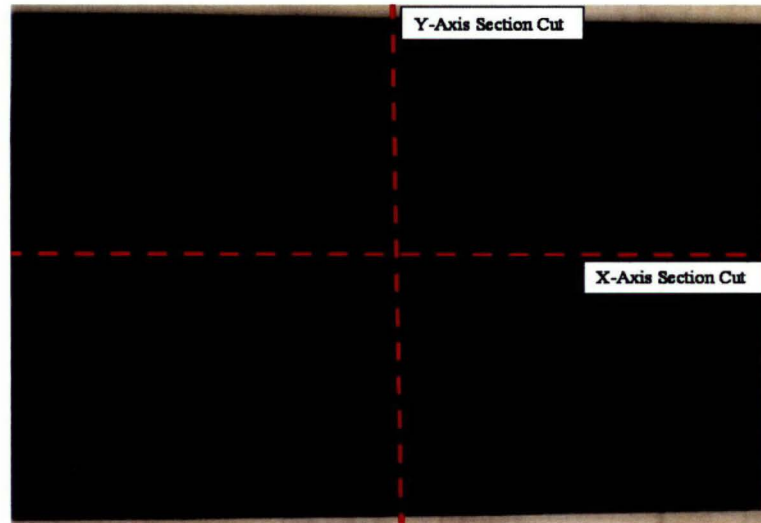

Representative MWM-Array Scan Image

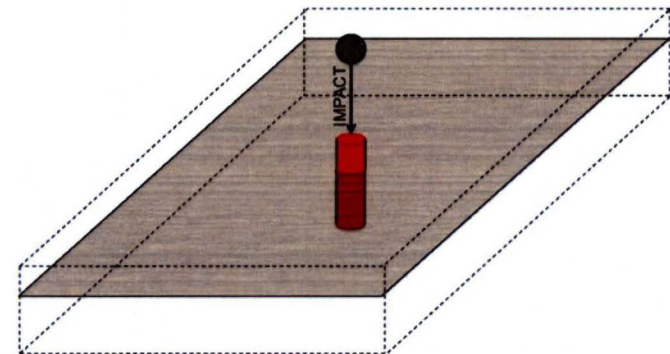
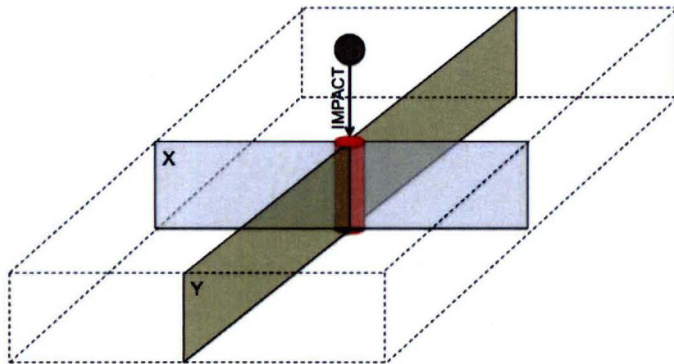
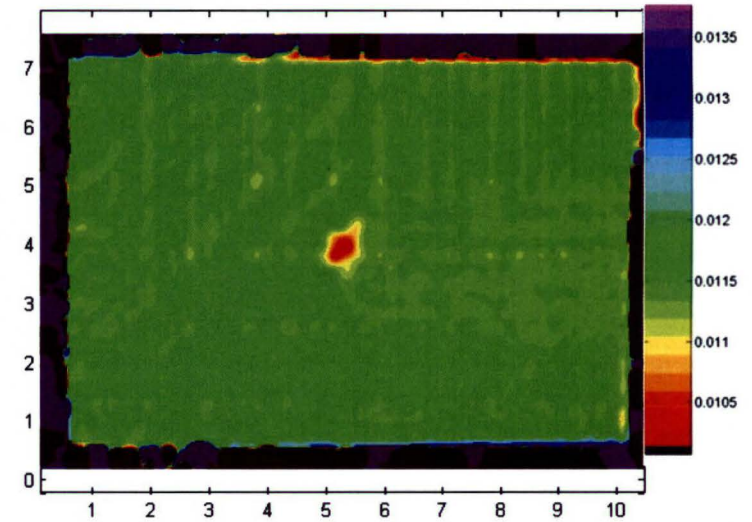

Representative Quasi-isotropic Panel Scan Images

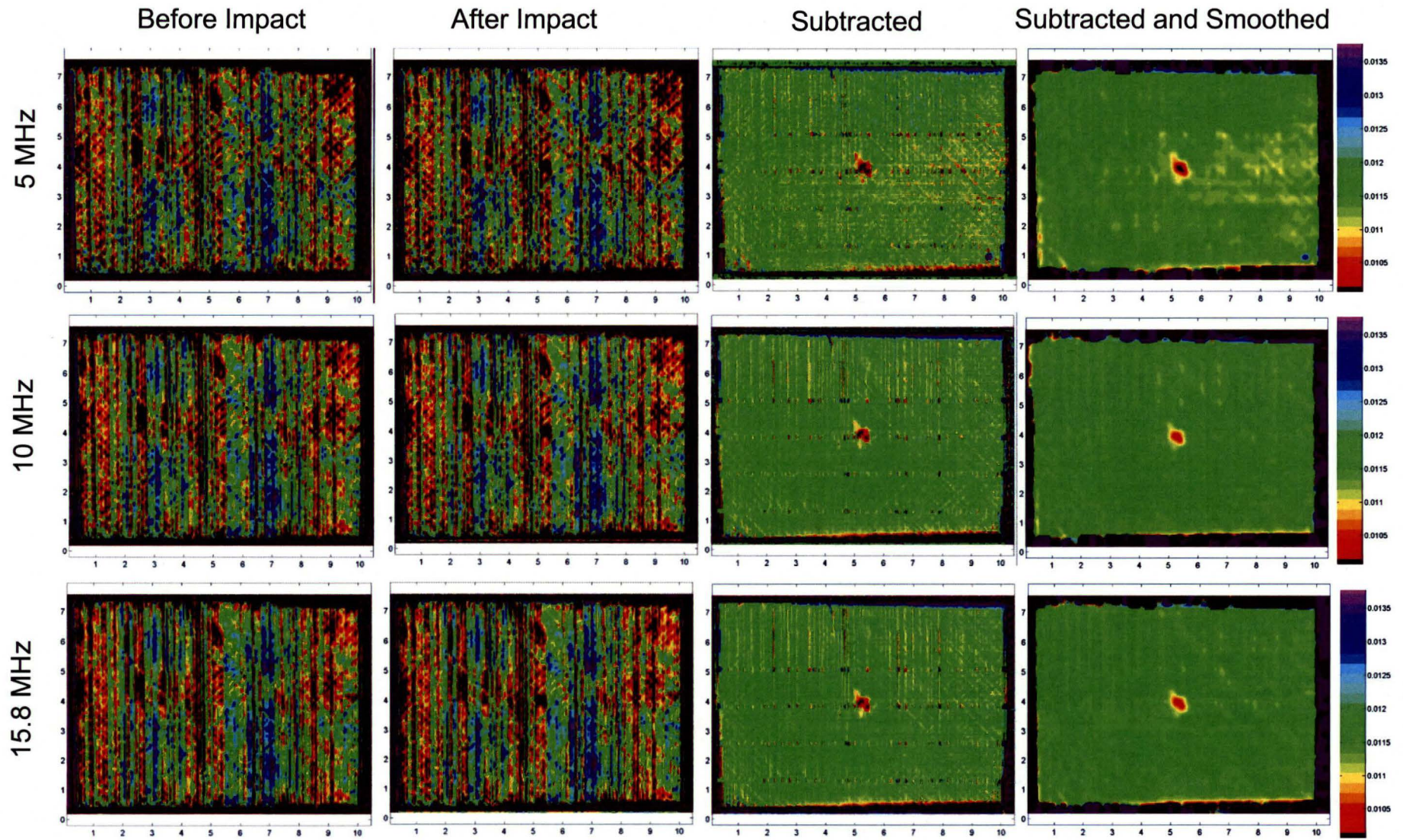

Summary of Scans

- Individual scans combined together to create composite cross-sectional view

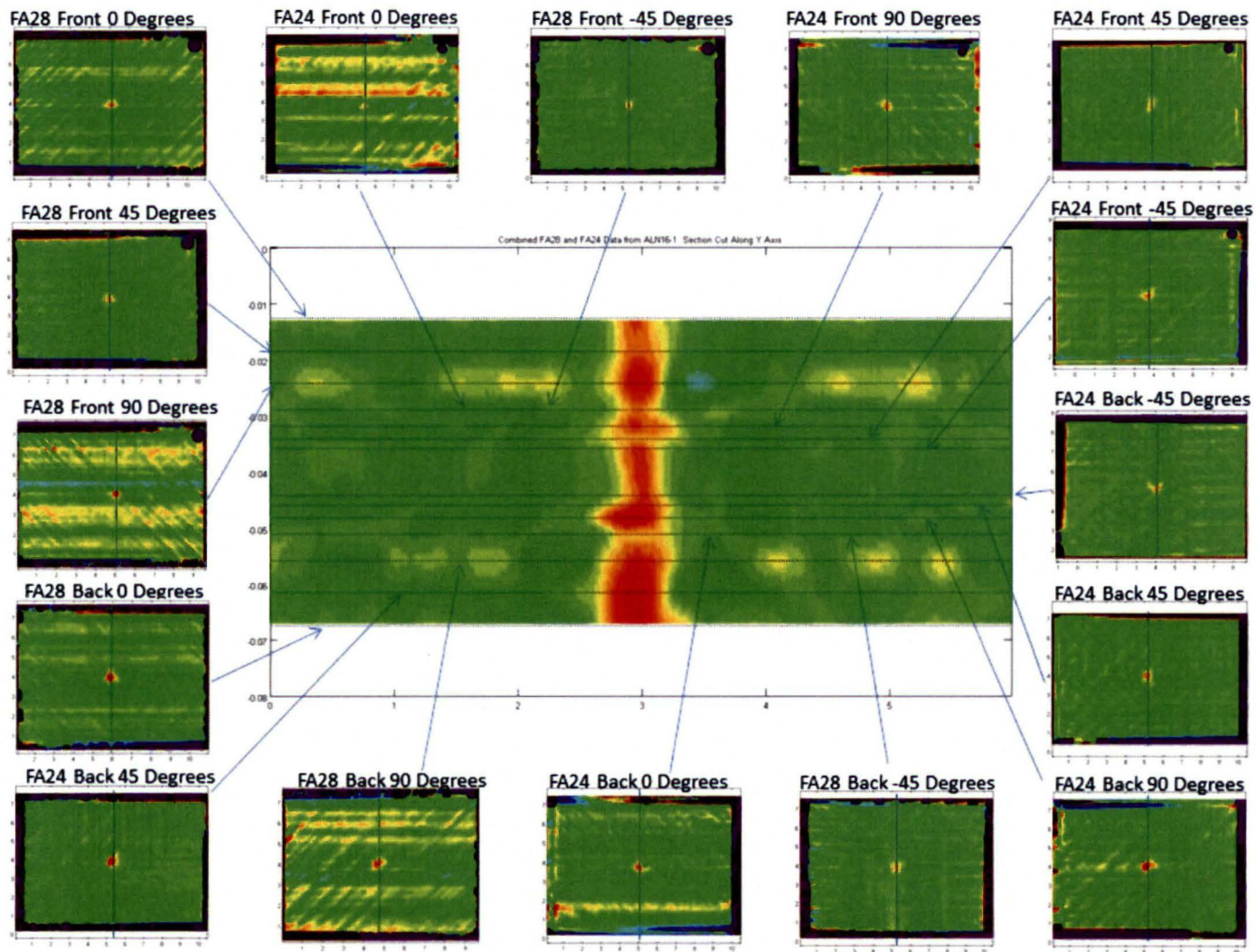

Cross Sectional Images: Panel 1, Low Impact Level

MWM-Array FA28 Data for 0.085-in. thick panels

Cross Sectional View along X-axis

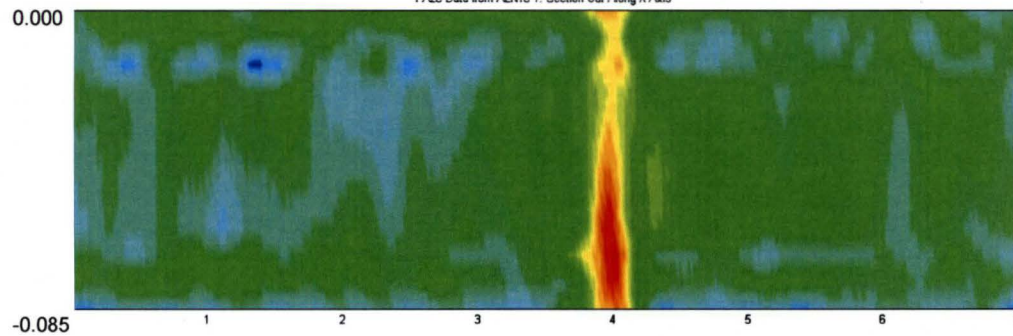

Cross Sectional View along Y-axis

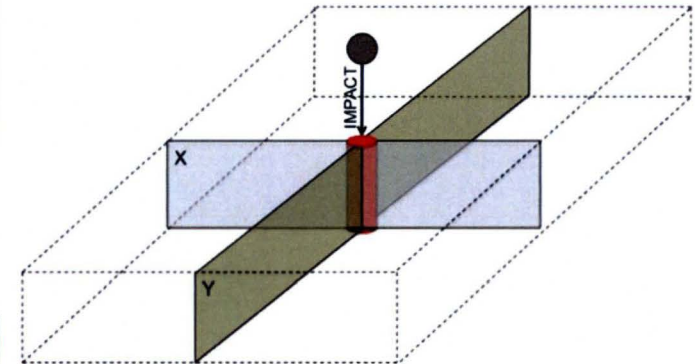
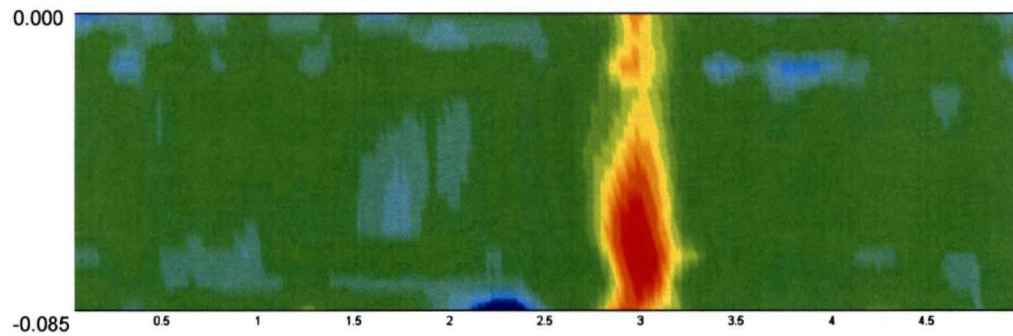

Cross Sectional Images: Panel 2, Medium Impact Level

MWM-Array FA28 Data for 0.085-in. thick panels

Cross Sectional View along X-axis

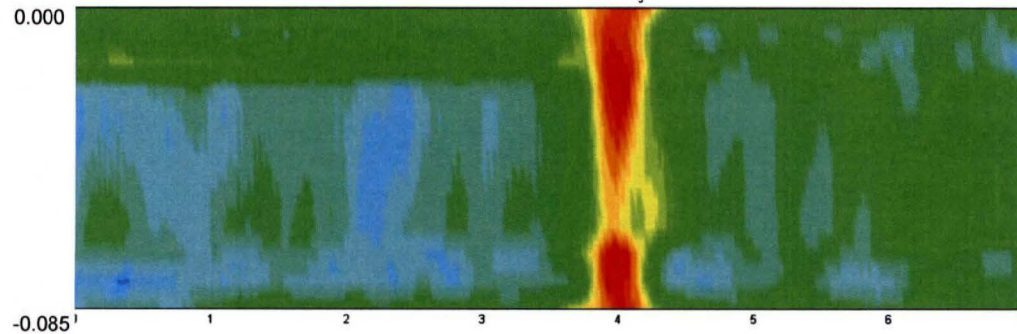

Cross Sectional View along Y-axis

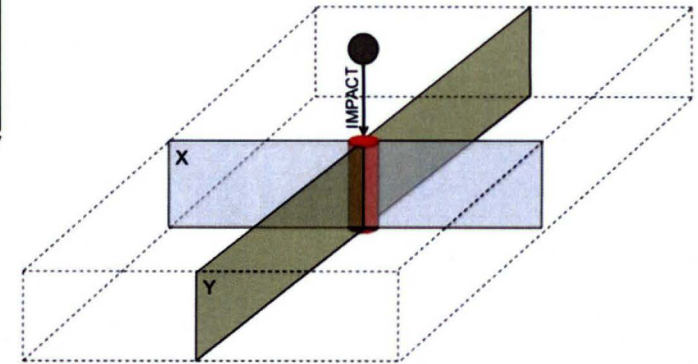
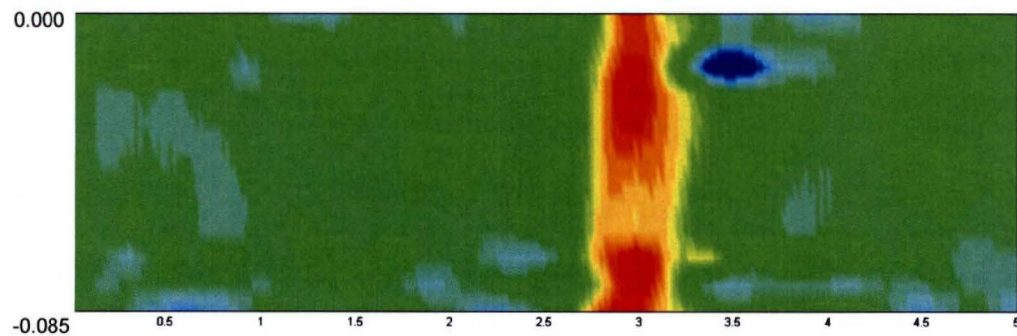

Cross Sectional Images: Panel 3, High Impact Level

MWM-Array FA28 Data for 0.085-in. thick panels

Cross Sectional View along X-axis

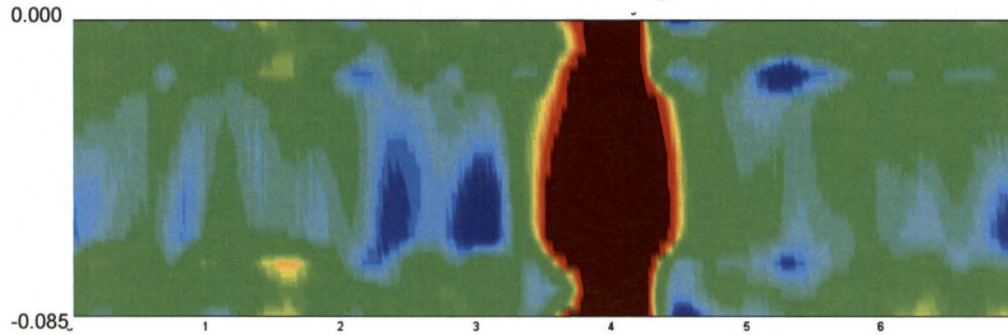

Cross Sectional View along Y-axis

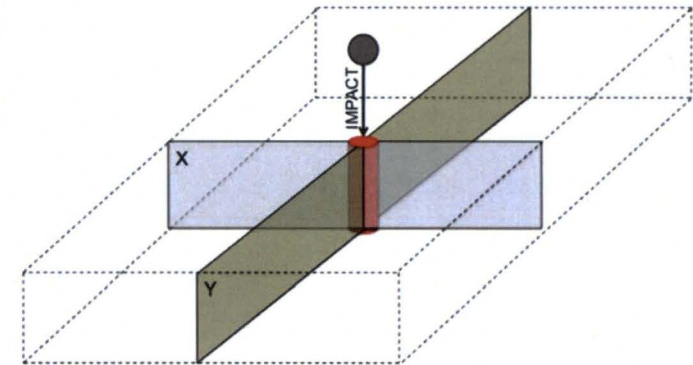
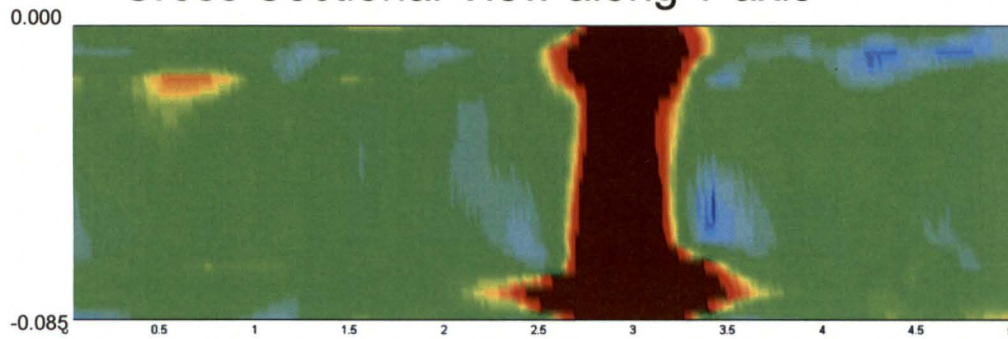

Stress Monitoring

- 4-pt bending on uniaxial specimen
- MWM-Array placed on tensile side
- Observe decrease in effective conductivity with increasing tensile load
- Frequency and channel-to-channel variations are attributed to the simplified models (conductivity/lift-off) used for this analysis



Representative Specimen

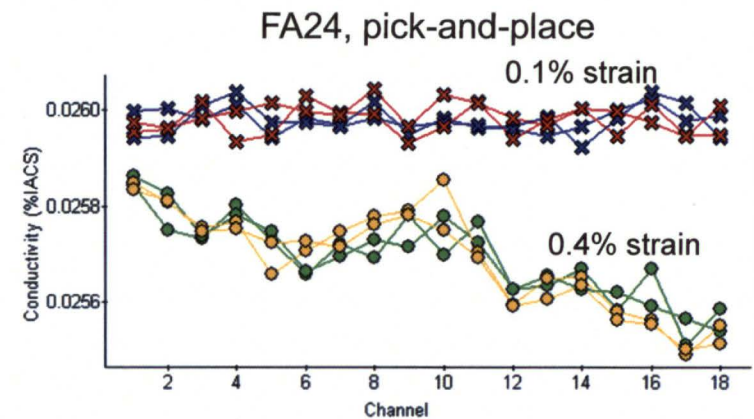
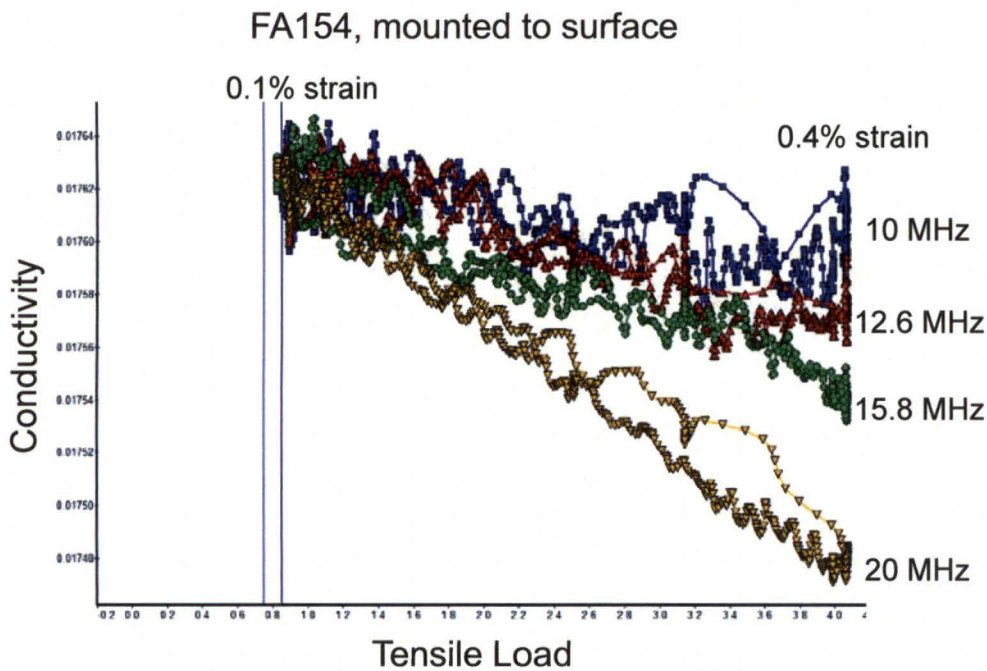

Example COPV Layup

- Representative layup for composite overwrapped pressure vessels
- MWM-Array sensitive to composite layers with fibers oriented parallel to drive windings
- This indicates that the sensor orientation is important for assessing the fiber properties.

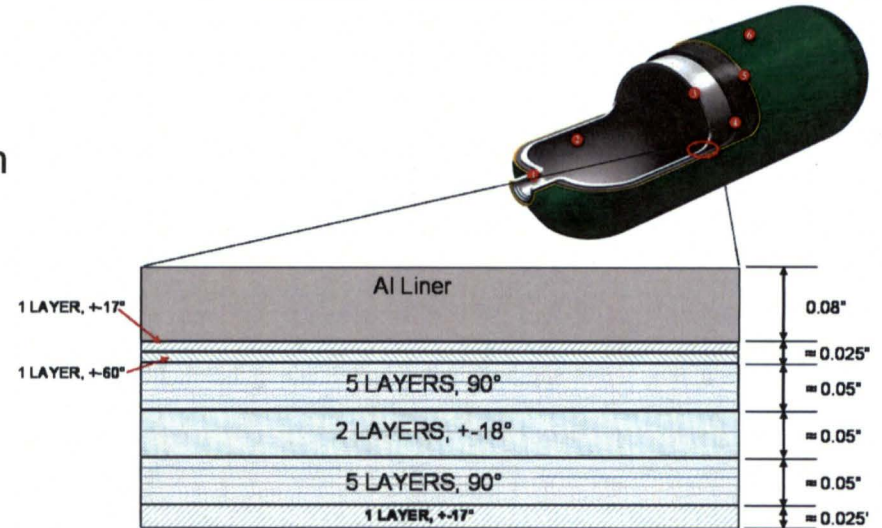

non-fiber orientation

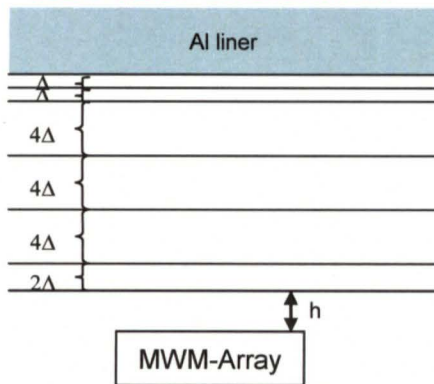

$\pm 17^\circ$ or $\pm 18^\circ$ orientation

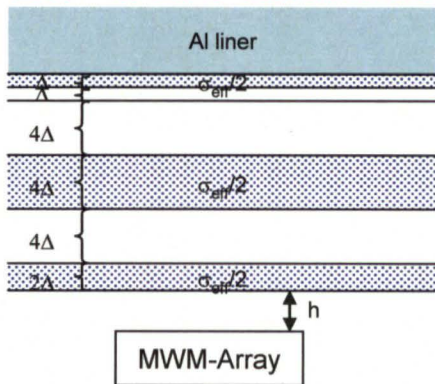

90° orientation

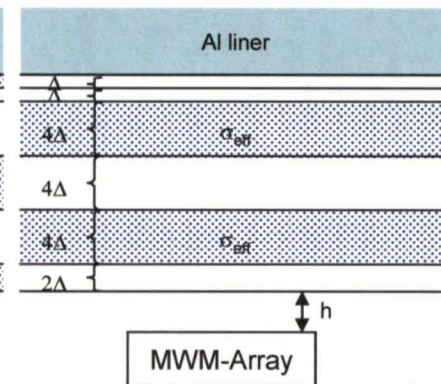

$\pm 60^\circ$ orientation

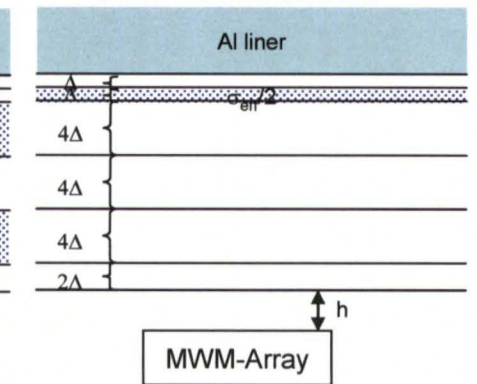

JENTEK Grids for MWM-Array on COPVs

- Representative grids for a composite overwrapped pressure vessel (COPV)
- Models account for layered geometry and orientation effects on properties within each layer
- Indicates that sensitivity to property variations in particular layers varies with fiber orientation, depth, and sensor selection.

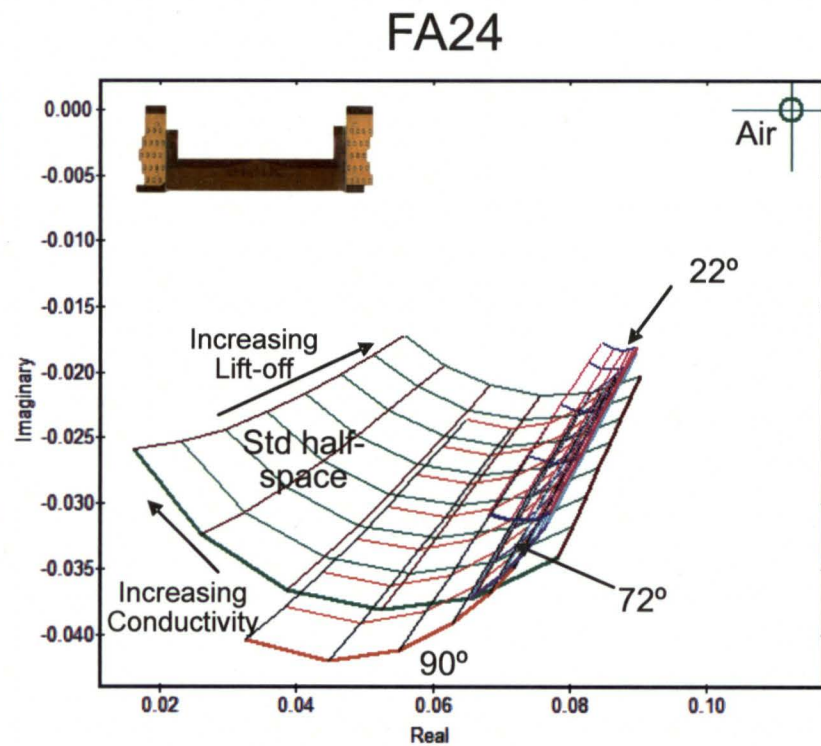
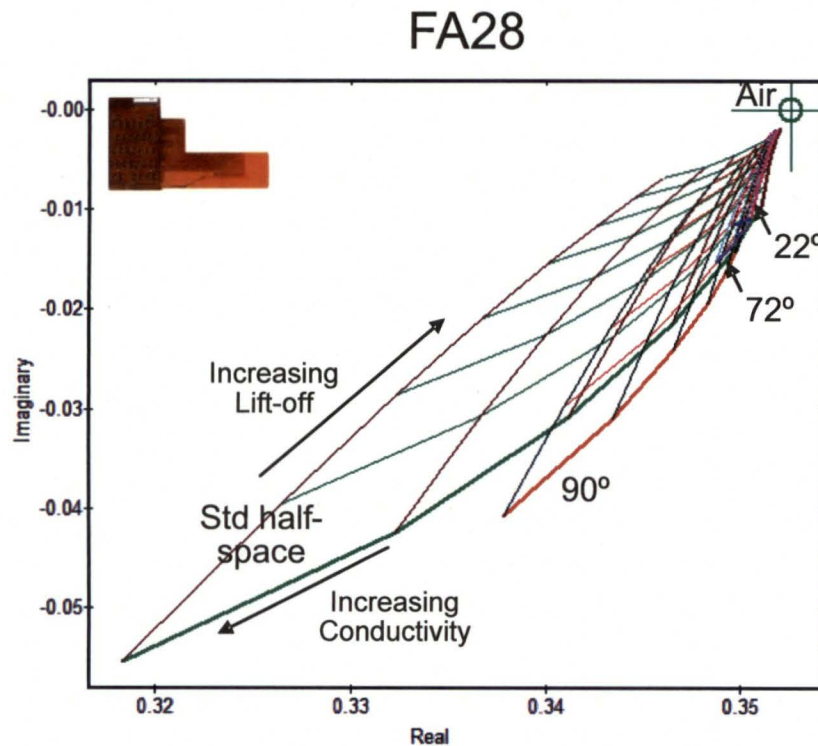

COPV Rotation Measurements

- Rotational measurements can be used to confirm fiber orientation in layup
- Indicates fibers oriented at approximately 13°, 73°, and 90° for this bottle

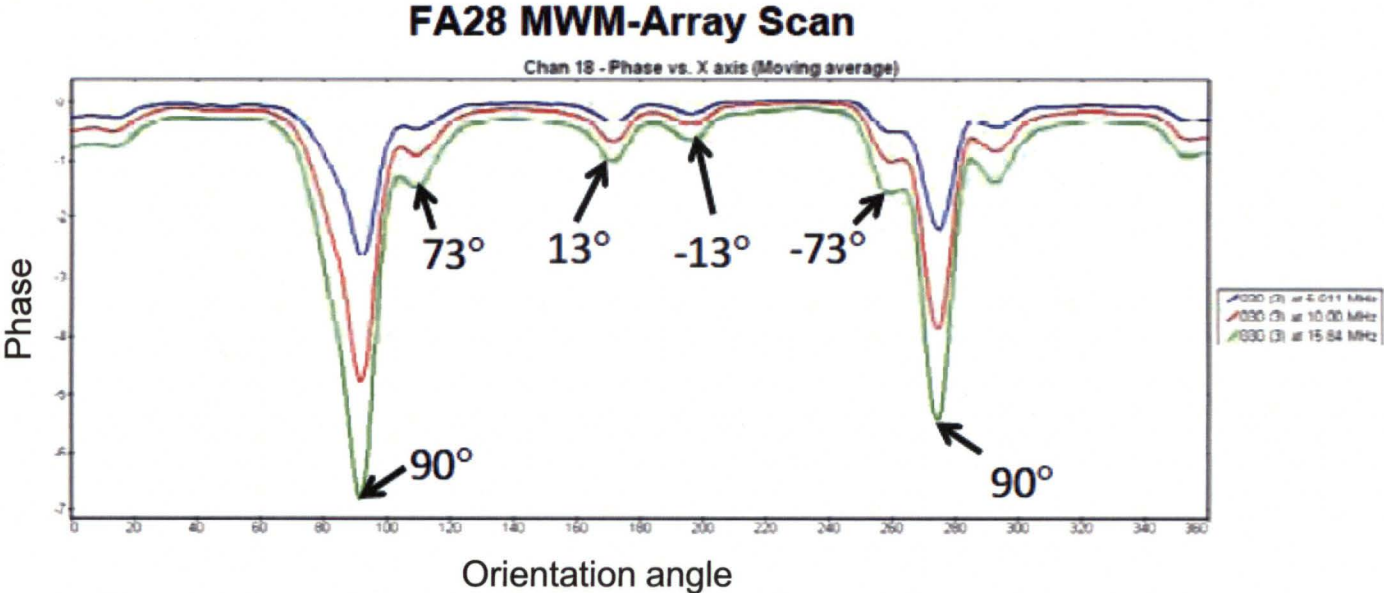
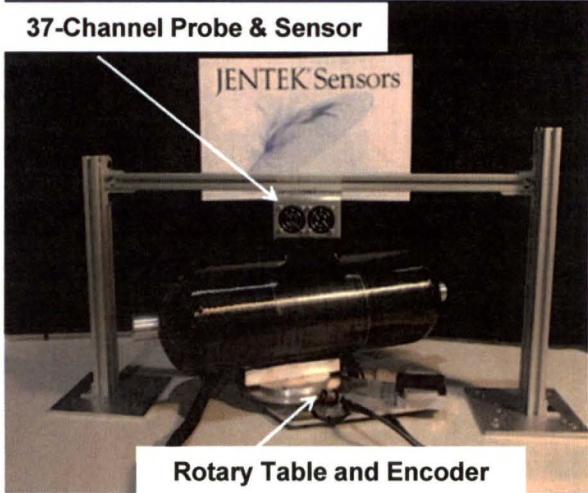

COPV Inspection and Monitoring

- Eddy current scans can image both liner and composite properties
- Potential for manufacturing quality control both before and after overwrap is applied
- Surface mounted arrays can provide information about COPV condition (e.g., stress)

Bottle Scanning Setup

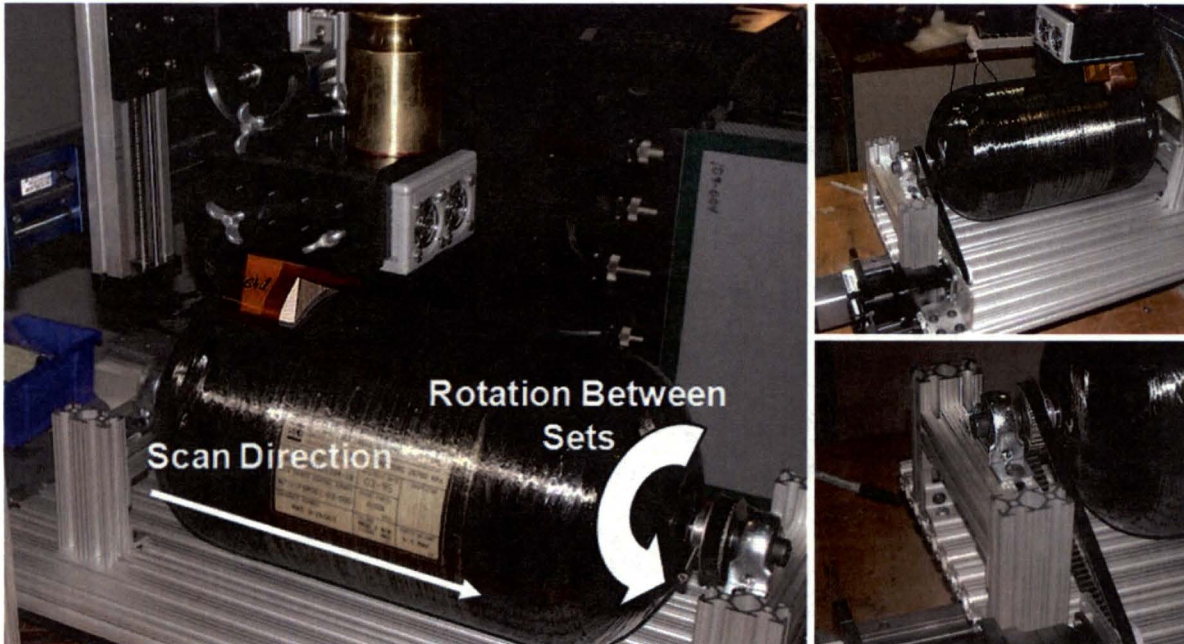

Surface-Mounted Setups

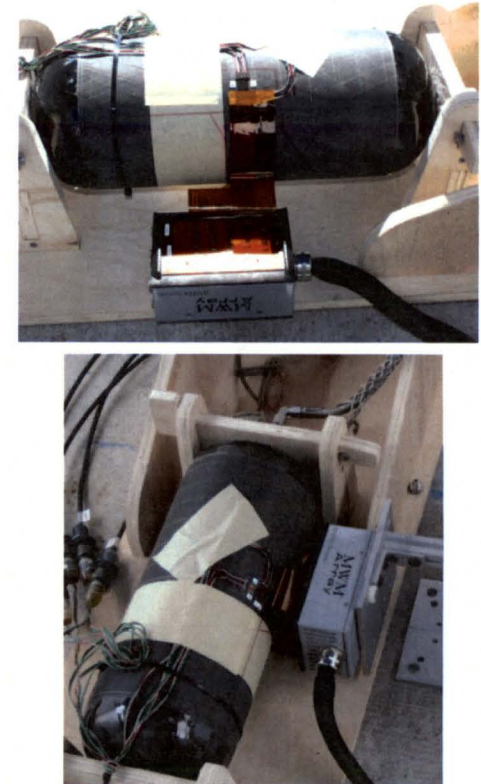

COPV: Low Frequency Inspection

- 50 kHz
- 90° drive orientation with 0.066-in. thick overwrap
- At this frequency the sensor responds primarily to the liner
- Effective lift-off images show dents in liner
- Higher impact energy results in larger dents in the aluminum liner

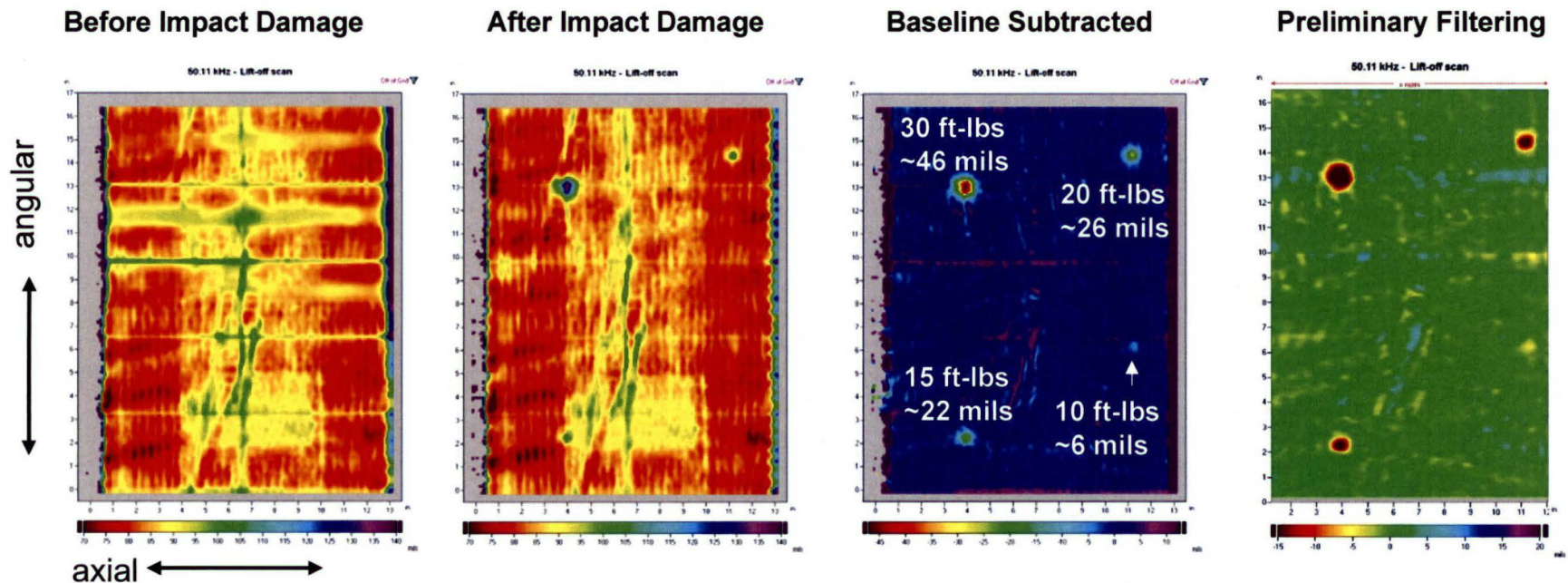

COPV: High Frequency Inspection

- 5 MHz
 - At this frequency more of the signal related to the composite overwrap properties
- 90° drive orientation with 0.066-in. thick overwrap
- The conductivity images show significant spatial variations in the overwrap properties
- Changes in the effective conductivity images highlight the damage

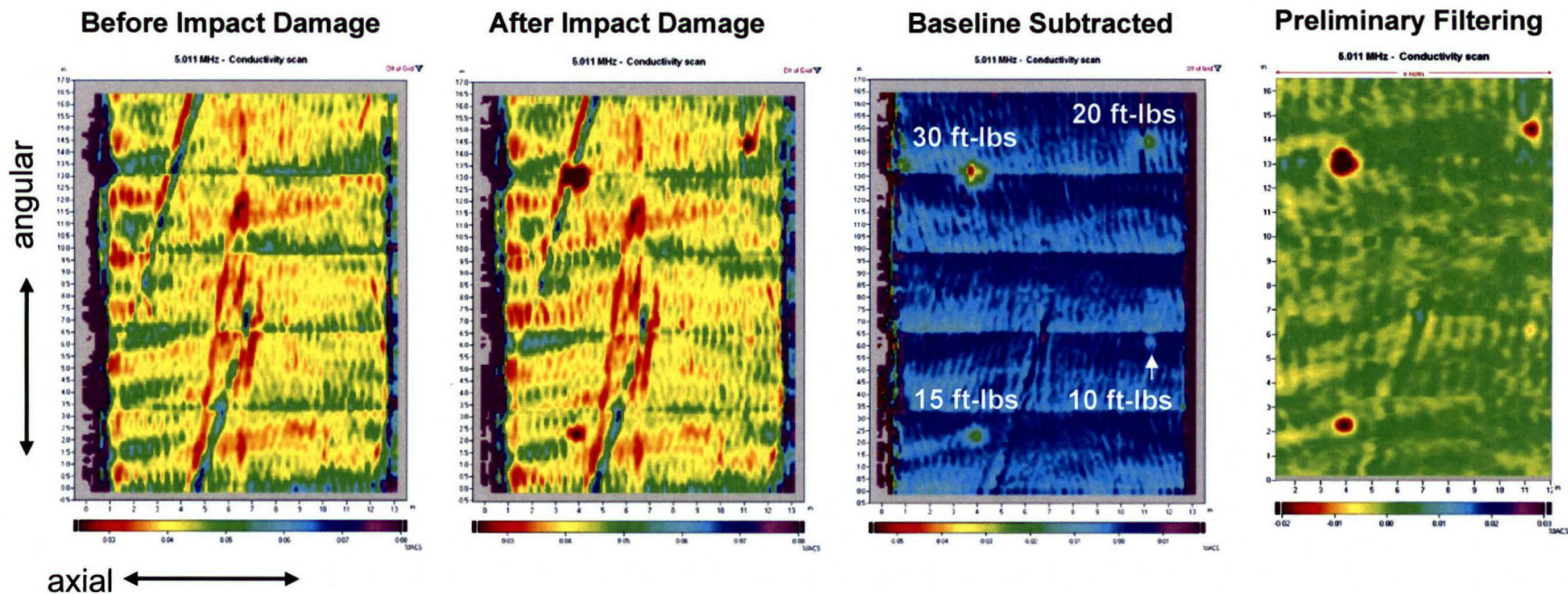

COPV: High Frequency Monitoring

- COPV hydrostatically pressurized for several cycles
- Near channels of FA49 used with the drive oriented parallel to the hoop fibers
 - For this configuration, these sense elements are only sensitive to the composite properties.
- Modest reduction in conductivity consistent with tensile strain and 4-pt bend test results

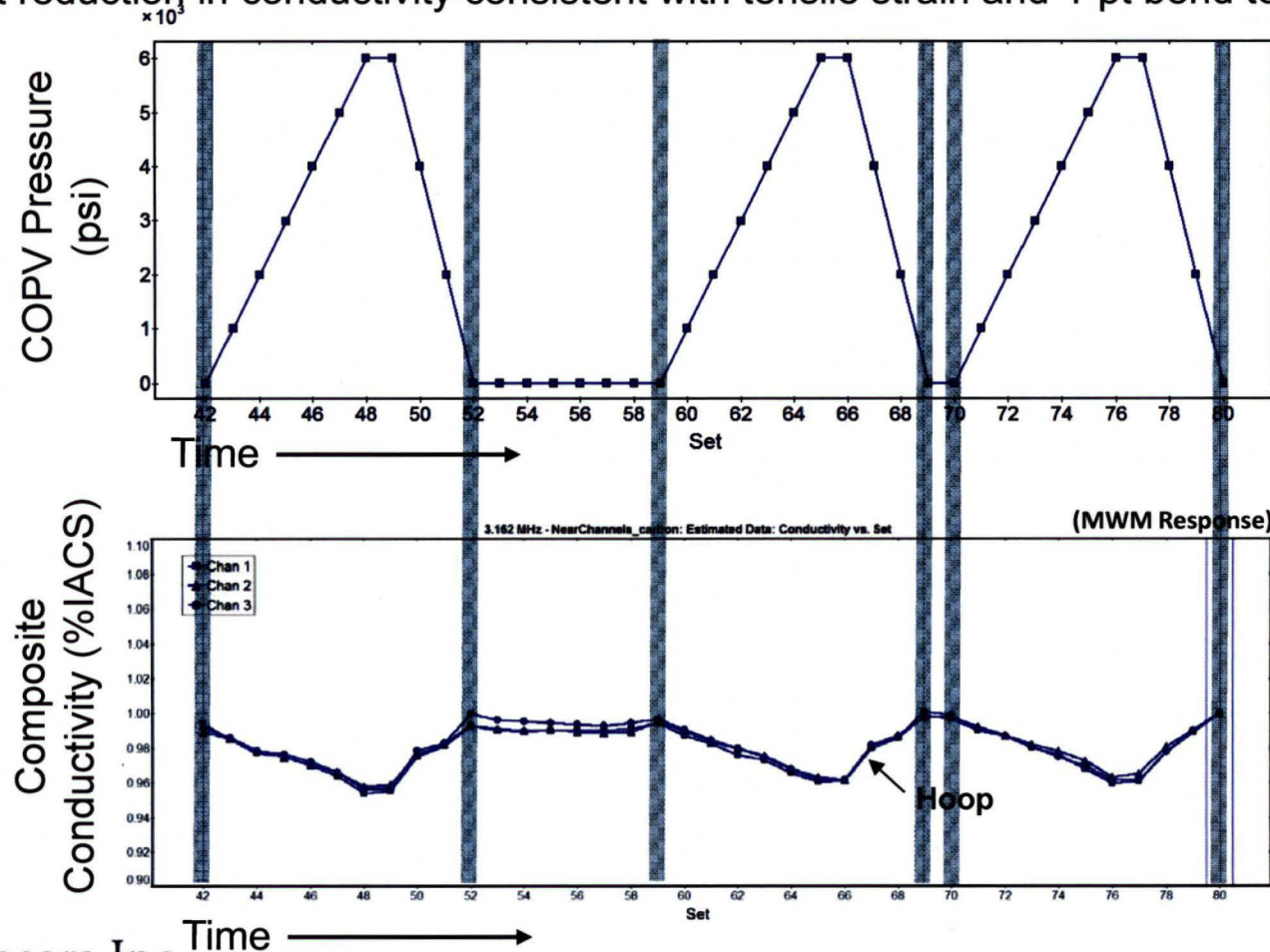

COPV: Low Frequency Monitoring

- “Very-far” FA49 channels used with the drives oriented parallel to the hoop or helical fibers
 - For this configuration, these sense elements are primarily sensitive to the composite thickness.
- Composite thickness is reduced with pressurization
- *The same array can be used to monitor both composite thickness and conductivity.*

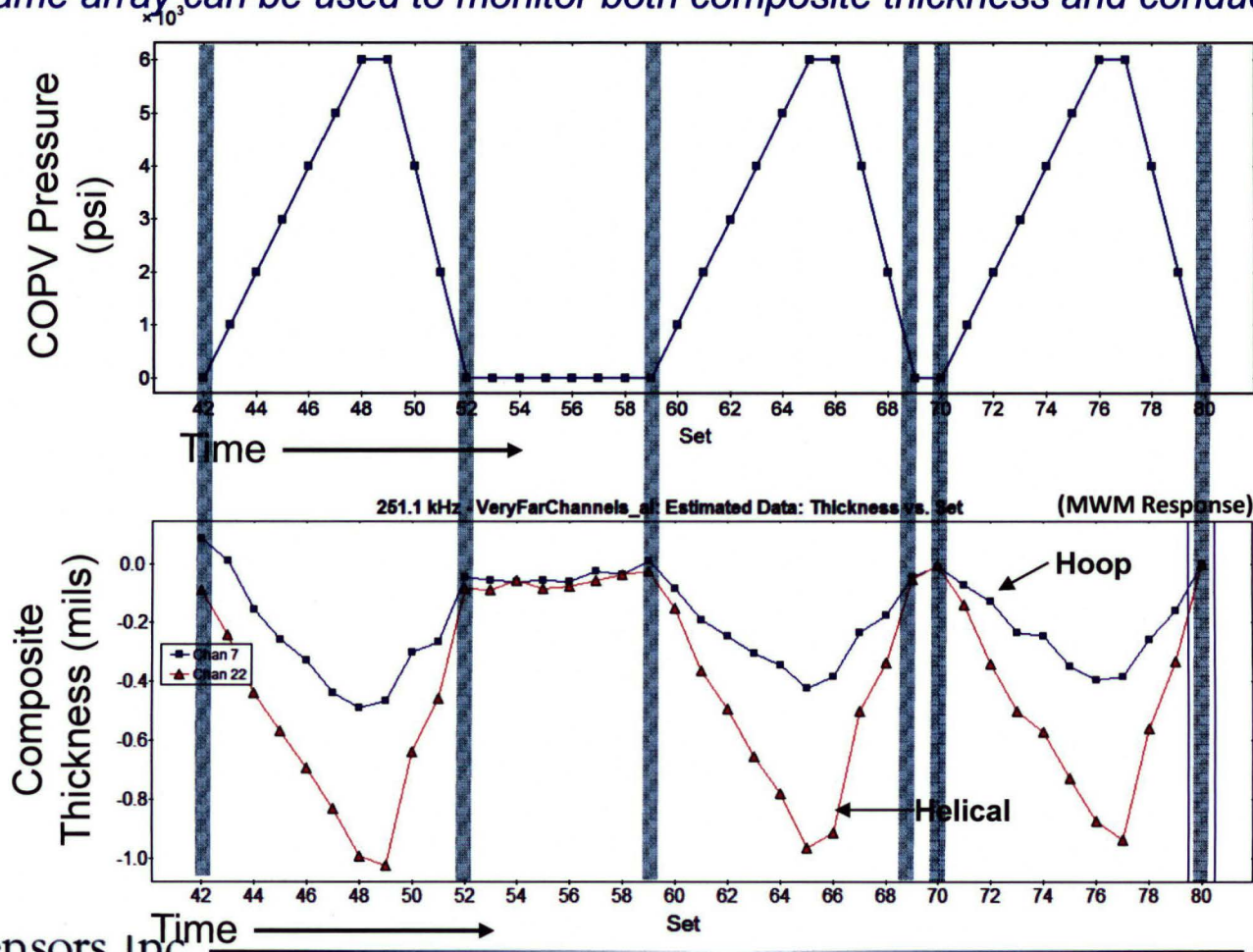

Summary

- An eddy current extension to a micromechanical model has been developed for conducting fiber composites.
- Layered-media models have been developed to account for anisotropic properties in composite plies.
- Eddy current sensor arrays with linear drives have shown a capability to determine fiber orientation and image fiber density variations in the composite.
- Data fusion with scans in various orientations and/or sensor geometries can be used to develop volumetric images of damage conditions.
- Stress monitoring of composites, for use in COPVs, has been demonstrated and is under development.



Questions?

The views and opinions expressed in this presentation are those of the authors and do not necessarily represent official policy or position of JENTEK Sensors, Inc., NASA, or any Department of the U.S. Government.

JENTEK® Sensors, Inc.

Phone: 781-642-9666

Email: jentek@jenteksensors.com

Website: www.jenteksensors.com

