

ISRU Propellant Selection for Space Exploration Vehicles

Timothy T. Chen¹

NASA Marshall Space Flight Center, Huntsville, Alabama 3885

Chemical propulsion remains the only viable solution as technically matured technology for the near term human space transportation to Lunar and Mars. Current mode of space travel requires us to “take everything we will need”, including propellant for the return trip. Forcing the mission designers to carry propellant for the return trip limits payload mass available for mission operations and results in a large and costly (and often unaffordable) design. Producing propellant via In-Situ Resource Utilization (ISRU) will enable missions with chemical propulsion by the “refueling” of return-trip propellant. It will reduce vehicle propellant mass carrying requirement by over 50%. This mass reduction can translate into increased payload to enhance greater mission capability, reduces vehicle size, weight and cost. It will also reduce size of launch vehicle fairing size as well as number of launches for a given space mission and enables exploration missions with existing chemical propulsion.

Mars remains the ultimate destination for Human Space Exploration within the Solar System. The Mars atmospheric consist of 95% carbon dioxide (CO₂) and the presence of Ice (water) was detected on Mars surfaces. This presents a basic chemical building block for the ISRU propellant manufacturing. However, the rationale for the right propellant to produce via ISRU appears to be limited to the perception of “what we can produce” as oppose to “what is the right propellant”. Methane (CH₄) is often quoted as a logical choice for Mars ISRU propellant, however; it is believed that there are better alternatives available that can result in a better space transportation architecture. A system analysis is needed to determine on what is the right propellant choice for the exploration vehicle.

This paper examines the propellant selection for production via ISRU method on Mars surfaces. It will examine propellant trades for the exploration vehicle with resulting impact on vehicle performance, size, and on launch vehicles. It will investigate propellant manufacturing techniques that will be applicable on Mars surfaces and address related issues on storage, transfer, and safety. Finally, it will also address the operability issues associated with the impact of propellant selection on ground processing and launch vehicle integration.

Nomenclature

C ₃ H ₈	=	Propane
CFM	=	Cryo-Fluid Management
CH ₄	=	Methane
CO ₂	=	Carbon Dioxide
ΔV	=	Impulsive Velocity
ECLSS	=	Environmental Controlled Life Support System
FTS	=	Fischer-Tropsch Synthesis
GSE	=	Ground Support Equipment
Isp	=	Engine Specific Impulse
ISRU	=	In Situ Resource Utilization

¹ AST, Aerospace Flight Systems, Spacecraft & Vehicle Systems Department, AIAA Senior Member

LH2 = Liquid Hydrogen
LO2 = Liquid Oxygen
MR = Oxidizer/ Fuel Mixture Ratio
NBP = Normal Boiling Point
PMF = Propellant Mass Fraction
RWGS = Reverse Water-Gas-Shift reaction Support System

I. Introduction

Human exploration to other planets within the Solar System remains an idea in a far distant future in part primarily due to the high development cost of the space transportation architecture. The cost of development for a Mars Lander/ Ascent Vehicle, an In-Space Propulsion Stage, and a launch vehicle capable of lifting the required mission mass to the Low Earth Orbit (LEO) are forbiddingly high. One key driver is the assumption that human space travel mission should “take everything with us”, including the return propellants. This drives a large mission mass required for the In-Space Propulsion Stage which in turns drives the required payload to LEO mass to be delivered by the launch vehicles.

The inter-dependency between the size and mass of Lander/ Ascent Vehicle, In-Space Propulsion Stage, and Launch Vehicle cannot be overlooked. One key limitation in launch vehicles is its payload volumetric constraint. If the diameter of its payload exceeds its design constraint, whether if they are encapsulated within fairing or exposed to atmosphere during ascent flight, it affects vehicle aerodynamic characteristics and flight stability. If the length of payload exceeds launch vehicle’s design constraint, it affects the flight stability as well.

The idea of In-Situ Resource Utilization (ISRU) take advantage of resources available on indigenous planets to produce the necessary materials and propellants for habitation, transportation, and life support so that one can minimize the required mission mass thereby reducing the development cost of the Exploration Transportation Architecture. For example, if one is able to produce propellant via ISRU it will enable missions with chemical propulsion by the “refueling” of return-trip propellant. It will reduce vehicle propellant mass carrying requirement by over 50%. In addition, if we are able to produce habitat materials and life support consumables using the ISRU process, we continue to reduce the size and mass of mission payloads thereby reducing the demand of lift capability and/ or number of launches of launch vehicle. This paper examines several candidate propellants suitable for ISRU production on Mars surfaces.

II. In-Situ Resource Utilization

In considering ISRU propellant selection, one must consider a bigger context of ISRU in general. In order to invest in an ISRU system on Mars surface, one must be able to produce other materials in addition to propellant. These materials include structures for habitation, power, Environmental Controlled Life Support System (ECLSS), as well as consumables such as water and food, etc. Therefore one recognizes that the propellant production is a part of overall “chemical manufacturing plant” that will enable a long term human habitation. Figure 1 shows synthetic chemical production paths using most basic elements that can be found on Mars surfaces, carbon dioxide (CO₂) and hydrogen (H₂). In addition to propellant production, one is able to produce basic chemical building blocks for materials, structures, and life support system.

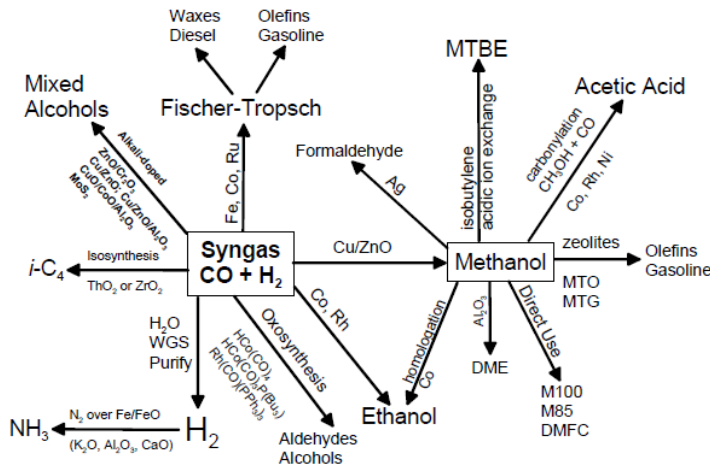

Figure 1: Synthetic Gas conversion processes (NREL report NREL/TP-510-34929, December 2003)

III Candidate ISRU Propellants

A candidate propellant must meet several criteria in order to be considered as basis for transportation architecture. One is that it must have the thermal stability required to operate in a liquid rocket engine, this include the ability to cool engine throat critical heat flux, avoid thermal decomposition and coking in engine coolant channels, and offers sufficiently high engine specific impulse (Isp). From a vehicle system perspective, it is the combined characteristic of propellant Isp and bulk density in meeting the vehicle impulsive velocity (ΔV) mission requirement that offers either the lowest mass or lowest propellant tank volume that warrants the selection. Table 1 list the candidate propellants considered in this system study.

Propellant	Tank Temp. (deg. R)	Density (lbm/ft ³)	Normal Boiling Point (deg.R)	Freezing Point (deg. R)
Liquid Oxygen, LO2	160	71.3		97.8
Liquid Hydrogen, LH2	38	4.4	36.6	25
Rocket Propellant -1, RP-1	ambient	50.4	825 min	400 max
NBP Methane, CH4	201	26.4	201	163.5
Subcooled Methane, CH4	183	27.3		
Subcooled Methanol, CH3OH*	320	56.3	608	316
NBP Propane, C3H8	416	36.3	416	154.2
Subcooled Propane, C3H8	180	44.8		
NBP Ethylene, C2H4	305	35.4	305	187.4
Subcooled Ethylene, C2H4	190	40.8		

Table 1: Candidate ISRU Propellants

Liquid Hydrogen (LH2) and Rocket Propellant -1 (RP-1) are included as reference propellant. LH2 is a cryogenic fuel with its Normal Boiling Point (NBP) at 36.6 degree Rankin. It has an excellent gravimetric heat of combustion (energy per mass) and it generates high Engine Isp when combusts with Liquid Oxygen (LO2). It is used in launch vehicles for first stage and upper stage applications. It is also considered as the fuel of choice by many for In-Space Propulsion Stage because of its high Isp value. The disadvantage of LH2 is that it has a low volumetric heat of combustion (energy per volume) due to its low density, tank insulation and Cryo-Fluid Management (CFM) techniques are required to reduce its boil-off due to its low boiling point. These add additional subsystems complexity and dry mass for the stage reducing its overall usable propellant mass fraction (PMF). RP-1 is a high density kerosene-based fuel commonly used in launch vehicles. Its main advantage is that it stored in ambient temperature thereby no tank insulation or tank thermal conditioning is required. Its density is closer to that of LO2 thereby offers total tank volume efficiency. The disadvantage of RP-1 for In-Space Propulsion application is that it freezes at -60 degree Fahrenheit (400 degree Rankine) which would required thick tank insulation or provide heaters to avoid the fuel freezing. Neither approach is considered practical for Space applications. Methane (CH4) offers advantage as “green” propellant that minimizes environmental impact with its exhausts. Its main advantage is the perceived ease of manufacturing via the ISRU method. Methanol was perceived as attractive ISRU

propellant due to its high density which could offer a lower propellant tank volume. Propane (C3H8) is selected as it offers a good range of low freezing point and relatively high boiling point. It is also a part of green propellant family and can be manufactured via the ISRU method that is similar to CH4 production. It also can be subcooled thereby increase its density and further reduces tank volume. Ethylene (C2H4) was selected because of its relative high Engine Isp, also as “green propellant”, and can be further subcooled to reduce tank volume.

Figure 2 show the parametric theoretical engine performance of candidate propellants over a range of oxidizer/ fuel mixture ratio (MR). A nominal lander/ ascent engine is assumed using pressure fed system. This chart enables us to find an optimum engine Isp MR for each propellant. LO2 is assumed as the oxidizer propellant. The Chemical Equilibrium Analysis (CEA) code used for this calculation was developed by McBride and Gordon at NASA-Glenn. It calculates thermodynamic equilibrium of combustion which is the maximum theoretical value one can obtain for a given oxidizer and fuel MR at a give chamber pressure and nozzle exit Area Ratio (AR).

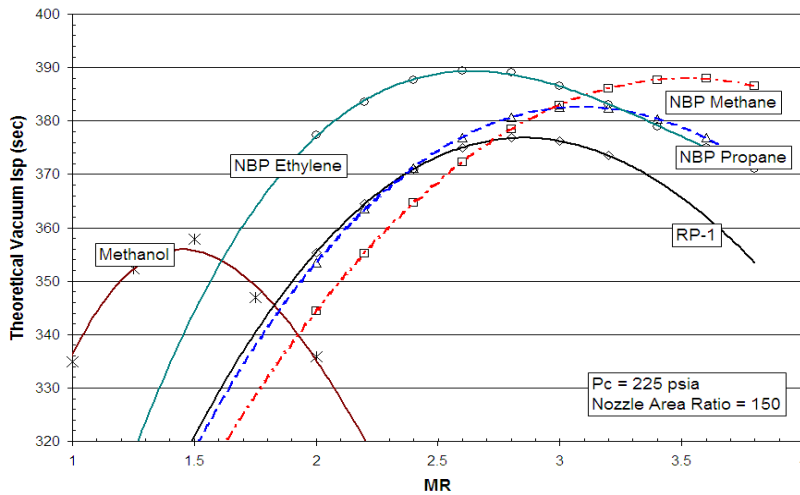

Figure 2: Theoretical Engine Performance for Selected Propellants (Calculation based on “Chemical Equilibrium Program (CEA) Calculation, CEA 97 by McBride and Gordon, NASA-Glenn”)

Figure 3 show the relative comparison of theoretical engine specific impulse at the selected MR for each propellant. The comparison uses RP-1 Isp as a reference. Since each propellant has a different value of optimum MR for this Isp value. Figure 4 shows the optimum MR selected for each propellant. Figure 5 shows the density comparison of candidate hydrocarbon fuels.

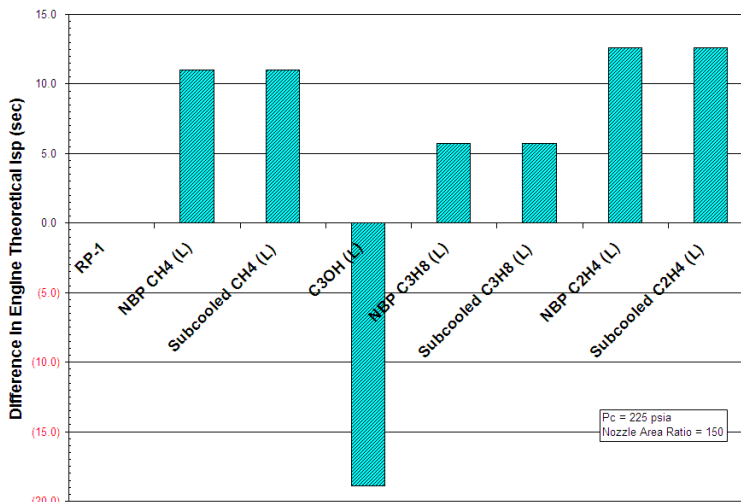

Figure 3: Engines Isp Performance Comparison vs. LO2/ RP-1

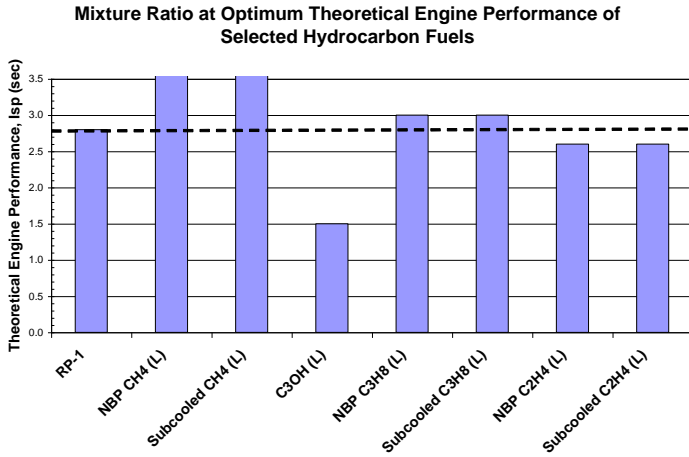

Figure 4: Mixture Ratio at Optimum Theoretical Engine Performance of Selected Hydrocarbon Fuels

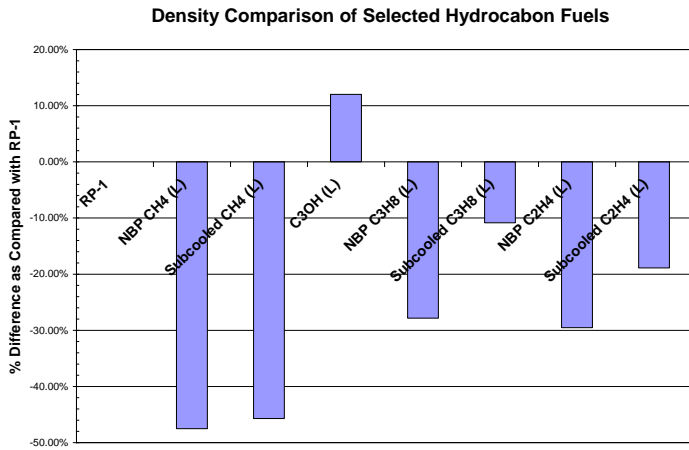

Figure 5: Propellant Density Comparison of Selected Hydrocarbon Fuels

We introduce the term Bulk Density of combined oxidizer and fuel at a given MR. Figure 6 shows the relative Bulk Density comparison.

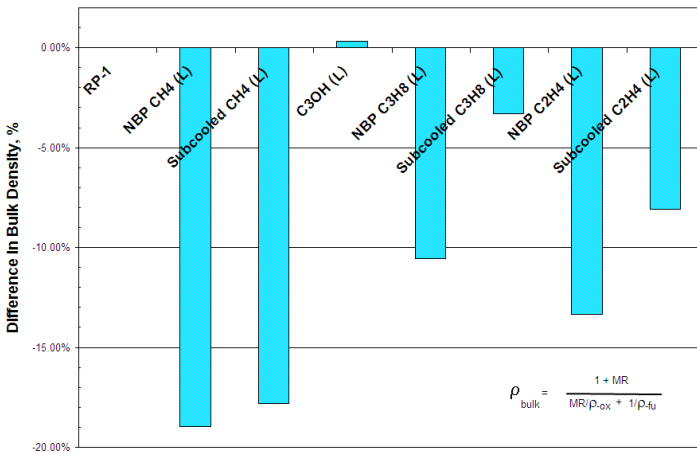

Figure 6: Bulk Density Incorporates MR Effects on Propellants

IV Vehicle Analysis

Two classes of vehicles are considered in this analysis, one is the Mars Lander/ Ascent Vehicle class with mission ΔV requirement in the 1 Km/sec to 2 Km/sec range. The other is the In-Space Propulsion Stage design to go from LEO to Mars orbit with mission ΔV requirement in the 6 Km/sec to 7 Km/sec range. The combined fuel and oxidizer propellant tanks volume will be used as the Figure of Merit (FOM) for this analysis with the lowest tank volume being the most attractive candidate propellant. The engine combustion efficiency is assumed at 94% across all propellant combinations.

In calculating total propellant tank volume, one starts with the Rocket Equation:

$$\Delta Vi = Isp * g_0 * LN \{ W\text{-initial}/ W\text{-final} \} \dots\dots\dots(\text{Eq. 1})$$

By manipulating Equation (1), one can obtain the direct relationship to total propellant volume

$$\text{Vol-propellant} \sim \frac{\text{EXP} \{ \Delta Vi/ Isp * g_0 \} - 1}{\rho \text{ bulk}} \dots\dots\dots (\text{Eq. 2})$$

Where $\rho_{\text{bulk}} = \frac{1 + MR}{MR/\rho\text{-oxidizer} + 1/\rho\text{-fuel}} \dots\dots\dots(\text{Eq. 3})$

Figure 7 shows the resulting calculation and compare the total tank volume with the LO2/ NBP CH4 for Lander/ Ascent Vehicle application. It is shown that, for the given mission ΔV , a subcooled C3H8 offers the lowest combined tank volume with LO2 as oxidizer. It is interesting to note that while CH3OH offers a high propellant bulk density, however; its low engine Isp reduces its system-level attractiveness. The result is consistent for In-Space Propulsion Stage application as shown in Figure 8. At a higher ΔV requirements, the attractiveness of CH3OH is further reduced while both subcooled C3H8 and C2H4 offers the benefit of reduced tank volume. This analysis shows that, among the candidate propellant selected, the subcooled propane (C3H8) provides a good engine performance Isp, a higher volumetric energy density thereby provides the lowest combined tank volumes for a given ΔV requirement for both the lander and In-Space Propulsion Stage applications.

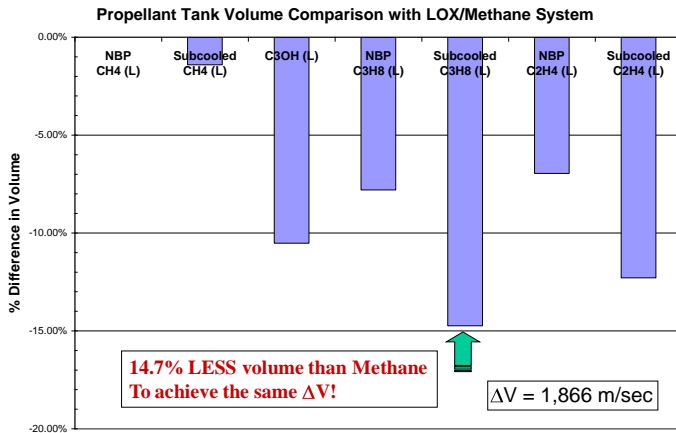

Figure 7: Propellant Tank Volume Comparison for Lander Application

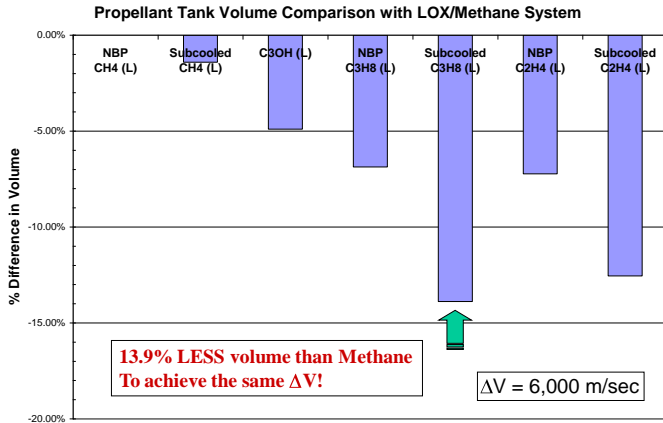

Figure 8: Propellant Tank Volume Comparison for In-Space Propulsion Stage Application

Figure 9 and Figure 10 show Hydrogen tank volume comparison with candidate hydrocarbons for Lander/Ascent Vehicle and In-Space Propulsion Stage applications, respectively. The high engine Isp of H2 can not overcome the low density of LH2 effect on tank volume. Subcooling of LH2 reduces tank volume somewhat it is still 60 – 80% larger volume than comparable hydrocarbon propellants.

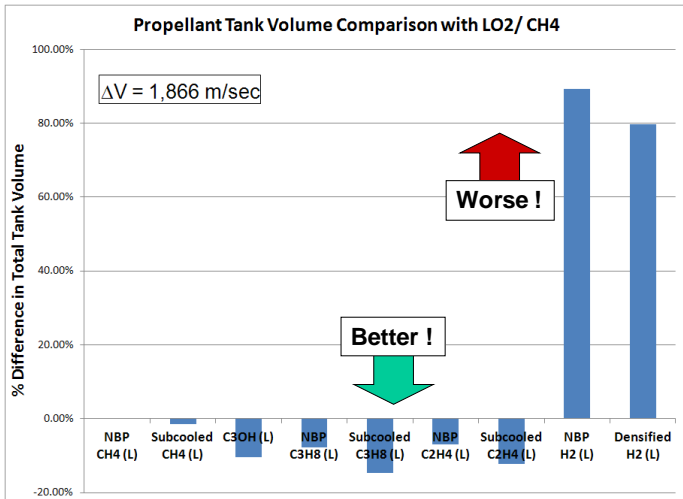

Figure 9: Hydrogen Propellant Tank Volume Comparison for Lander Application

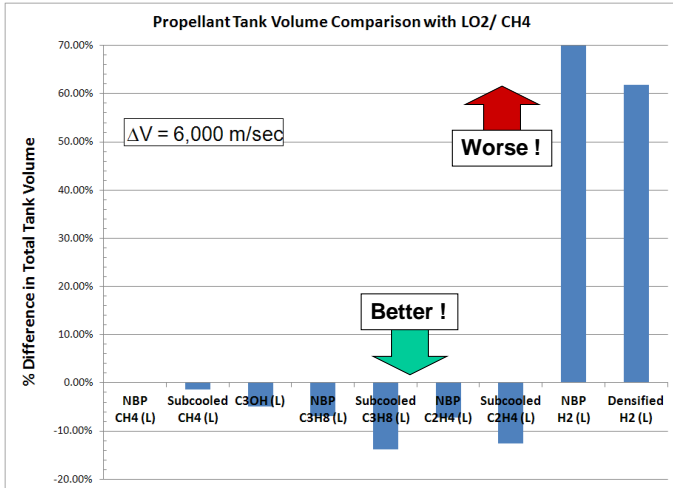

Figure 10: Hydrogen Propellant Tank Volume Comparison for In-Space Propulsion Stage Application

V Chemistry of Synthetic Propane Production

The next logical step is to investigate the technology readiness of ISRU production of Propane on Mars surface. One can leverage the synthetic fuel technology for ISRU propane production via the Fischer-Tropsch Synthesis. The Fischer-Tropsch Synthesis (FTS) was invented by Franz Fischer and Hans Tropsch in 1920s. Both Germany and Japan used this technology to produce synthetic fuels to power its military and industry energy needs. Today, the SASOL plant in South Africa produces aviation grade synthetic jet fuel for all commercial airlines that stop over at the OR Tambo International Airport in Johannesburg.

The Fischer-Tropsch Synthesis robust process that can be tailored to produced different chemicals by manipulating the processing condition and catalyst. The common feedstock is Carbon Monoxide (CO) and Hydrogen (H₂). The CO is obtained through the Reverse Water-Gas-Shift (RWGS) reaction of Carbon Dioxide (CO₂) and H₂. The Mars atmosphere contains approximately 95% CO₂. It is assumed that one can extract the CO₂ from the atmosphere. The H₂ supply is assumed by the electrolytic separation of water, H₂O, and collects and store the H₂ as feedstock.

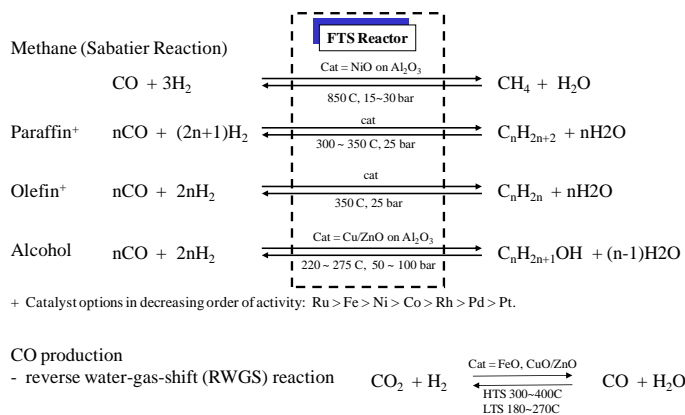
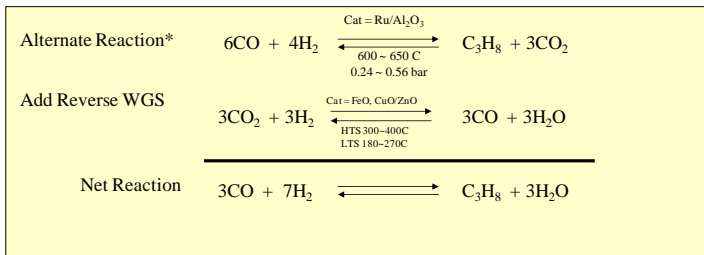
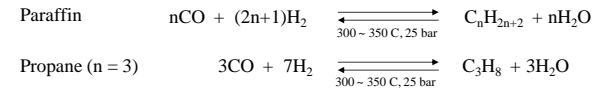

Figure 9: Specific Fischer-Tropsch Synthesis (FTS) Chemistry

The term “paraffin” (C_nH_{2n+2}) includes linear chain hydrocarbons. If the selected product is CH₄ then n=0, if C₃H₈ then n=3, etc. Figure 10 shows the specific chemistry of C₃H₈ production.



* Sutton, Moisan and Ross "Kinetic study of CO₂ reforming of propane over Ru/Al₂O₃", Catalysis Letters Vol. 75, No. 3-4, 2001

Figure 10: Synthetic Propane Production

Figure 11 shows the overall ISRU production of Methane (CH₄) and Propane (C₃H₈). The Methane production is perceived as simple and within the technology readiness. It can be shown that the ISRU production of Propane is not more complex than Methane production.

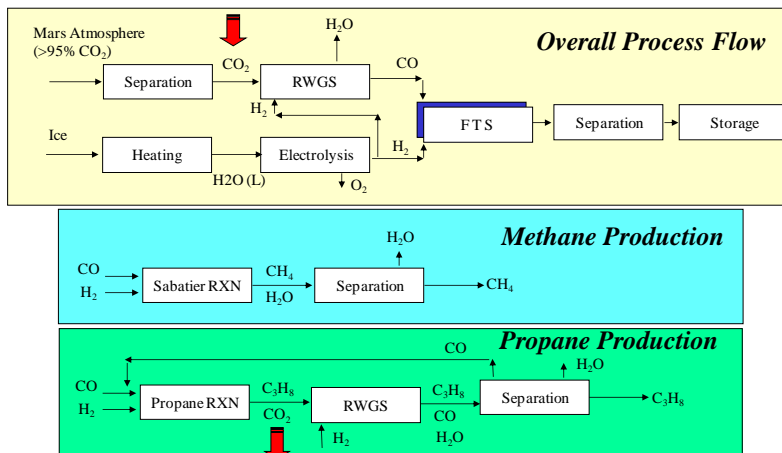

Figure 11: Mars ISRU Propellant Production Process Flow

III. Conclusion

A system analysis on candidate ISRU propellant selection was conducted to examine its impact on vehicle propellant tank volume. Results indicate that alternative ISRU propellant candidates are available that, in addition being producible on Mars via the ISRU method, but offer vehicle level benefits with reduced tank volume hence reducing size of vehicles including Lander/ Ascent Vehicle, In-Space Propulsion Stage, and Launch Vehicle fairing diameter. Propane shows promise as candidate ISRU propellant with combined high bulk density and good engine Isp, can satisfy the mission ΔV for both Lander and In-Space Propulsion Stage applications. The propane can be easily produced via ISRU on Mars surface using the Fischer-Tropsch process via the synthetic fuel technology which is matured and demonstrated.



49th AIAA/ASME/SAE/ASEE
Joint Propulsion Conference
San Jose, California

AIAA-2013-3804

ISRU Propellant Selection for Space Exploration Vehicles

16 July 2013

Timothy T. Chen

NASA Marshall Space Flight Center

Introduction

- **Human Space Exploration to Mars**
 - ❑ Ultimate destination for Human Space Exploration within the Solar System.
 - ❑ Development Cost is forbiddingly high
 - Lander/Ascent Vehicle
 - In-Space Propulsion Stage
 - Launch Vehicle
 - ❑ High Development Cost driven by Mission Concept of Operation (ConOps) Assumptions
 - Take Everything With Us
 - Drives a large In-Space Propulsion Stage requirement
 - Drives advanced technologies not yet matured
 - Multiple launches and vehicle self-assembly in space
 - Nuclear propulsion technologies
 - Zero Boil-Off (ZBO) cryogenic propellant storage and transfer

Human Space Exploration to Mars

- **Chemical propulsion remains the only viable solution in the near term**
 - ❑ Technically matured technology
- **Mission driven vs. Technology-driven**
 - ❑ Go explore while maturing “breakthrough” propulsion technologies
- **Ability to minimize Exploration Vehicles size enables exploration missions with existing chemical propulsion.**
 - ❑ Reduce Launch Vehicles fairing constraints (diameter/ length)
 - ❑ Minimize number of launches
 - ❑ Reduce on-orbit wait time, rendezvous, docking
- **Ability to produce propellant via In-Situ Resource Utilization (ISRU) reduces Exploration Vehicle sizes**
 - ❑ Reduce Propellant carry requirement by 50%
 - ❑ Reduces propellant tank diameter/ length
 - ❑ Reduces number of launches

In-Situ Resource Utilization (ISRU)

In space exploration, in-situ resource utilization (ISRU) describes the proposed use of resources found or manufactured on other astronomical objects (the Moon, Mars, Asteroids, etc.) to further the goals of a space mission

- Wikipedia

- **Benefits of producing propellant via ISRU**
 - ❑ Reduce vehicle propellant mass carrying requirement by over 50%.
 - Able to replenish propellant at destination
 - Reduce vehicle size requirements
 - Reduce number of launches from ground
- **Ability to produce structures and materials for human habitation and life support systems**

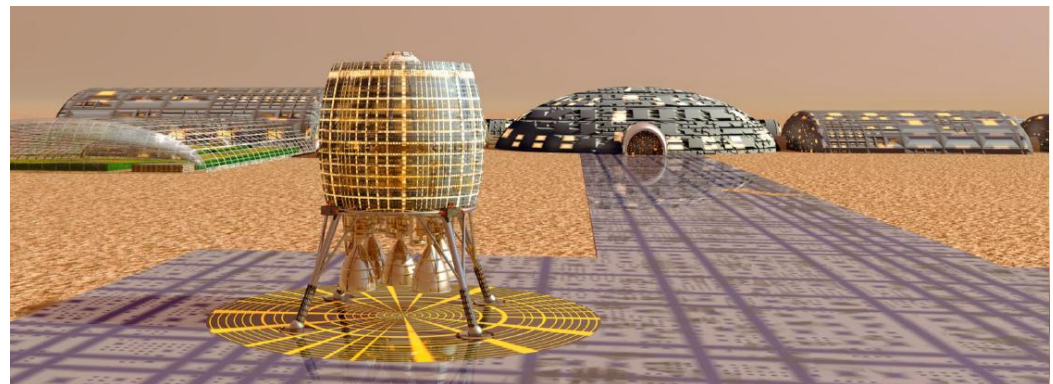

ISRU Propellant Selection

- **The propellant selection rationale must satisfy the following requirements:**
 - Spacecraft level (Lander/Ascent Vehicle, In-Space Propulsion Stages) requirements**
 - Mission performance (ΔV)
 - Low boil-off/ Low freezing point
 - Minimum vehicle size preferred (see launch vehicle constraints)
 - Engine operating environment**
 - Cooling, thermal stability and combustion performance
 - Launch vehicle (fairing diameter/ length/ lift mass) constraints**
 - Multiple launches drive other technologies that need to be developed and matured
 - Ability to manufacture selected propellant on Mars via ISRU**
 - Available resources, manufacturing technologies

ISRU Propellant Selection Rationale

- **Liquid Hydrogen (LH2)**
 - High engine specific impulse (Isp). Currently used for Upper Stage to LEO/ GEO missions. Used in Saturn S-IVB Stage for Apollo Missions.
- **Rocket Propellant-1 (RP-1)**
 - Ambient temperature kerosene-based hydrocarbon fuel. Currently used for launch vehicles boost stage and 2nd stage. Use as reference only.
- **Methane (CH4)**
 - Current candidate as “green” propellant for ISRU production due to perceived ease of manufacturing
- **Methanol (CH3OH)**
 - Candidate for ISRU propellant due to its high fuel density
- **Propane (C3H8)**
 - Candidate for ISRU propellant due to its combined high engine Isp and high fuel density
- **Ethylene (C2H4)**
 - A highly reactive fuel. Same rationale as Propane.

Candidate ISRU Propellants

Propellant	Tank Temp. (deg. R)	Density (lbm/ft ³)	Normal Boiling Point (deg.R)	Freezing Point (deg. R)
Liquid Oxygen, LO2	160	71.3		97.8
Liquid Hydrogen, LH2	38	4.4	36.6	25
Rocket Propellant -1, RP-1	ambient	50.4	825 min	400 max
NBP Methane, CH4	201	26.4	201	163.5
Subcooled Methane, CH4	183	27.3		
Subcooled Methanol, CH3OH*	320	56.3	608	316
NBP Propane, C3H8	416	36.3	416	154.2
Subcooled Propane, C3H8	180	44.8		
NBP Ethylene, C2H4	305	35.4	305	187.4
Subcooled Ethylene, C2H4	190	40.8		
* NBP = 608 deg. R				

RP-1 for reference only due to its high freezing point

Theoretical Engine Performance for Selected Propellants

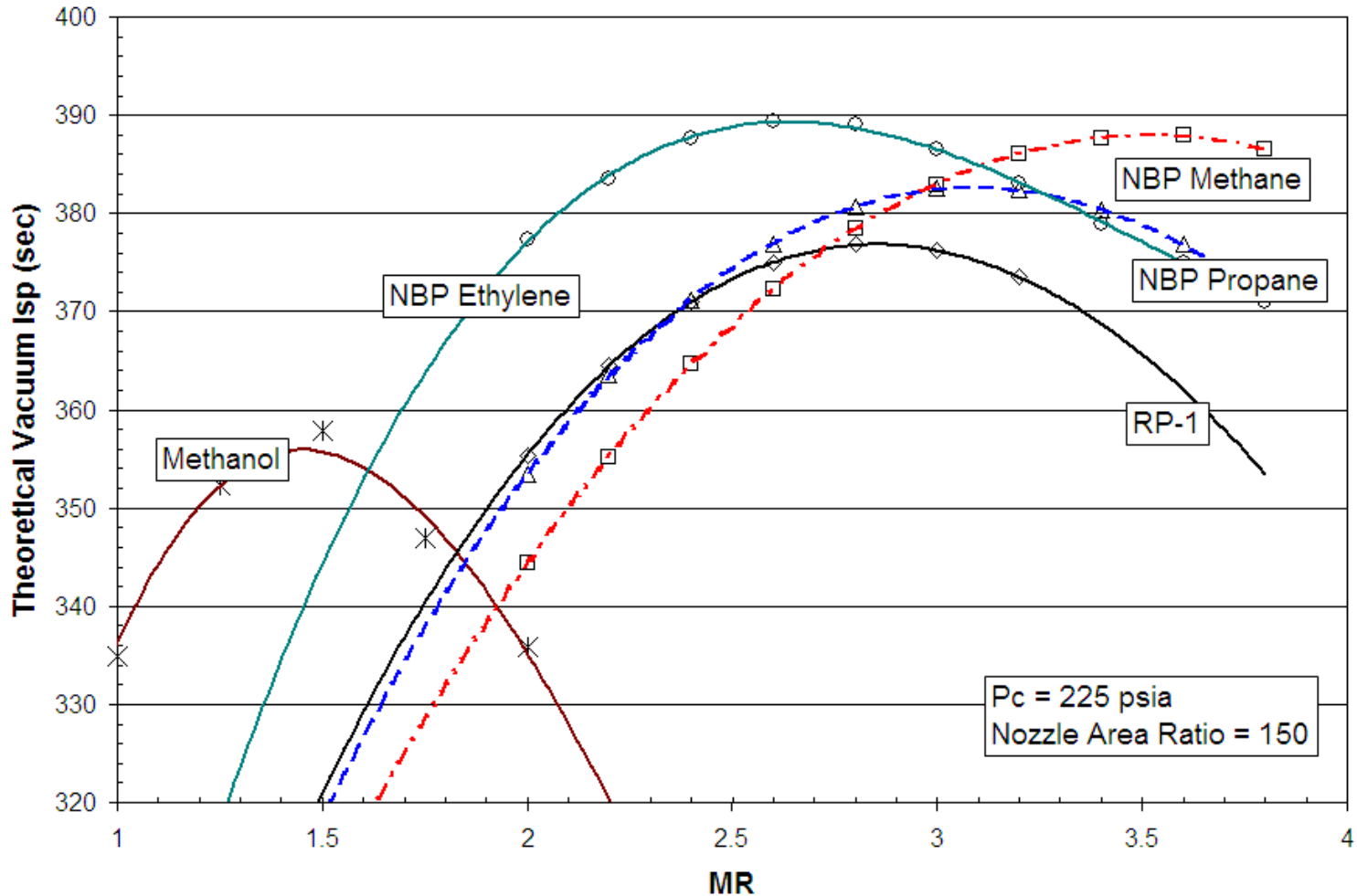

Chemical Equilibrium Analysis (CEA) code calculation, CEA 97 by McBride and Gordon, NASA-GRC

Theoretical Performance Comparison vs. LO2/ RP-1

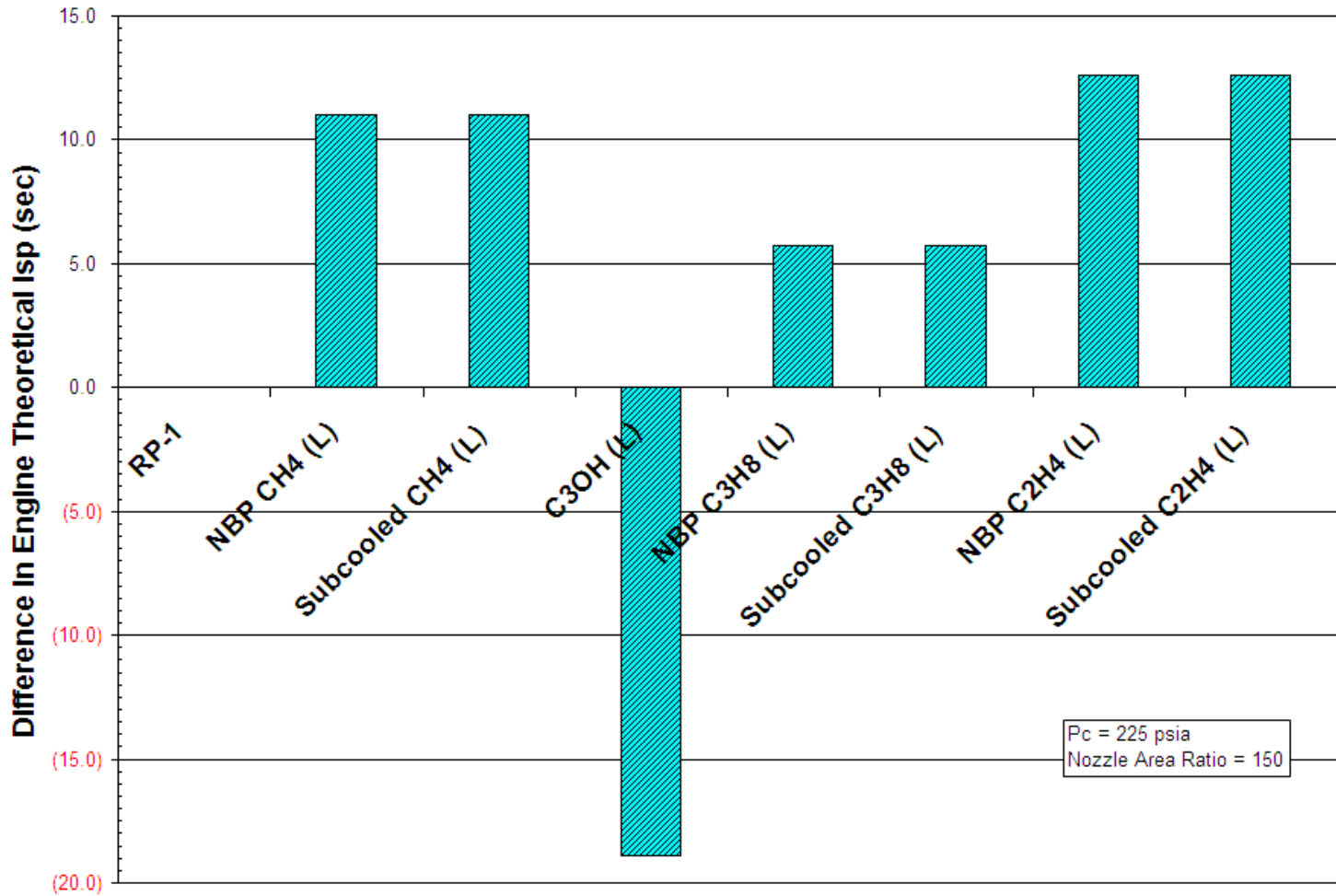

Optimum Mixture Ratio for various Propellants

Mixture Ratio at Optimum Theoretical Engine Performance of Selected Hydrocarbon Fuels

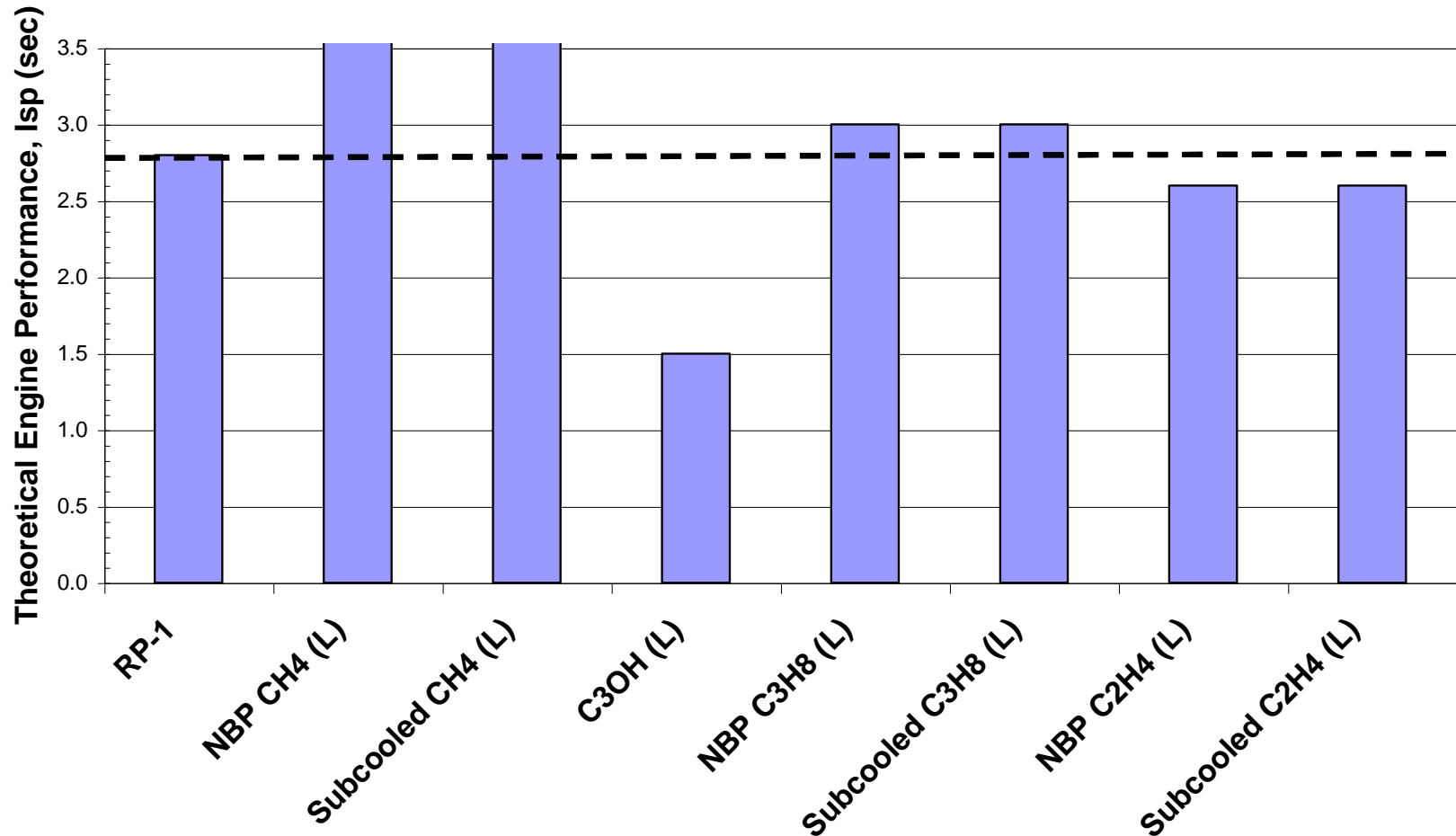

Fuel Density Comparison

Density Comparison of Selected Hydrocarbon Fuels

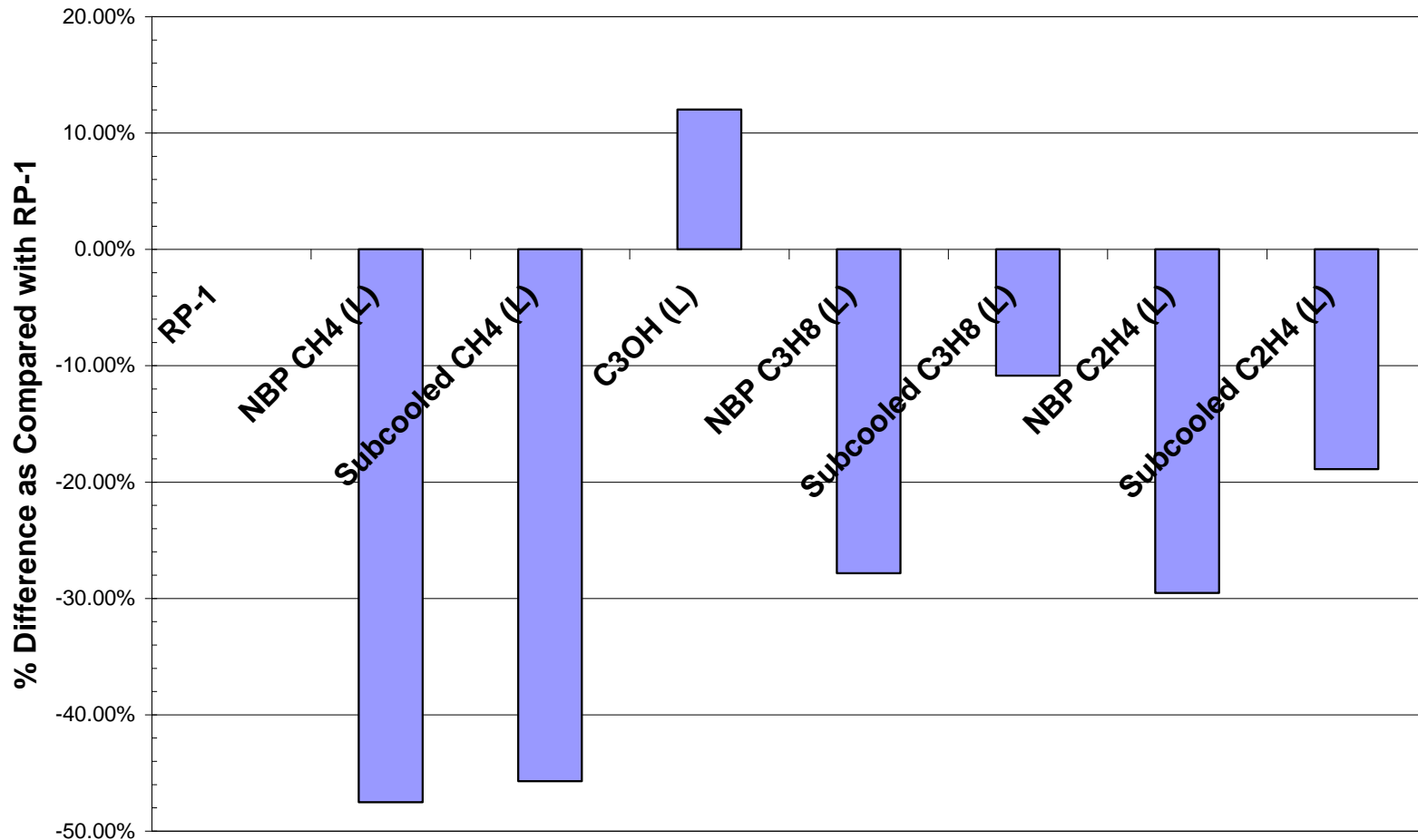

Combined Fuel/ Oxidizer Density Comparison at Optimum MR

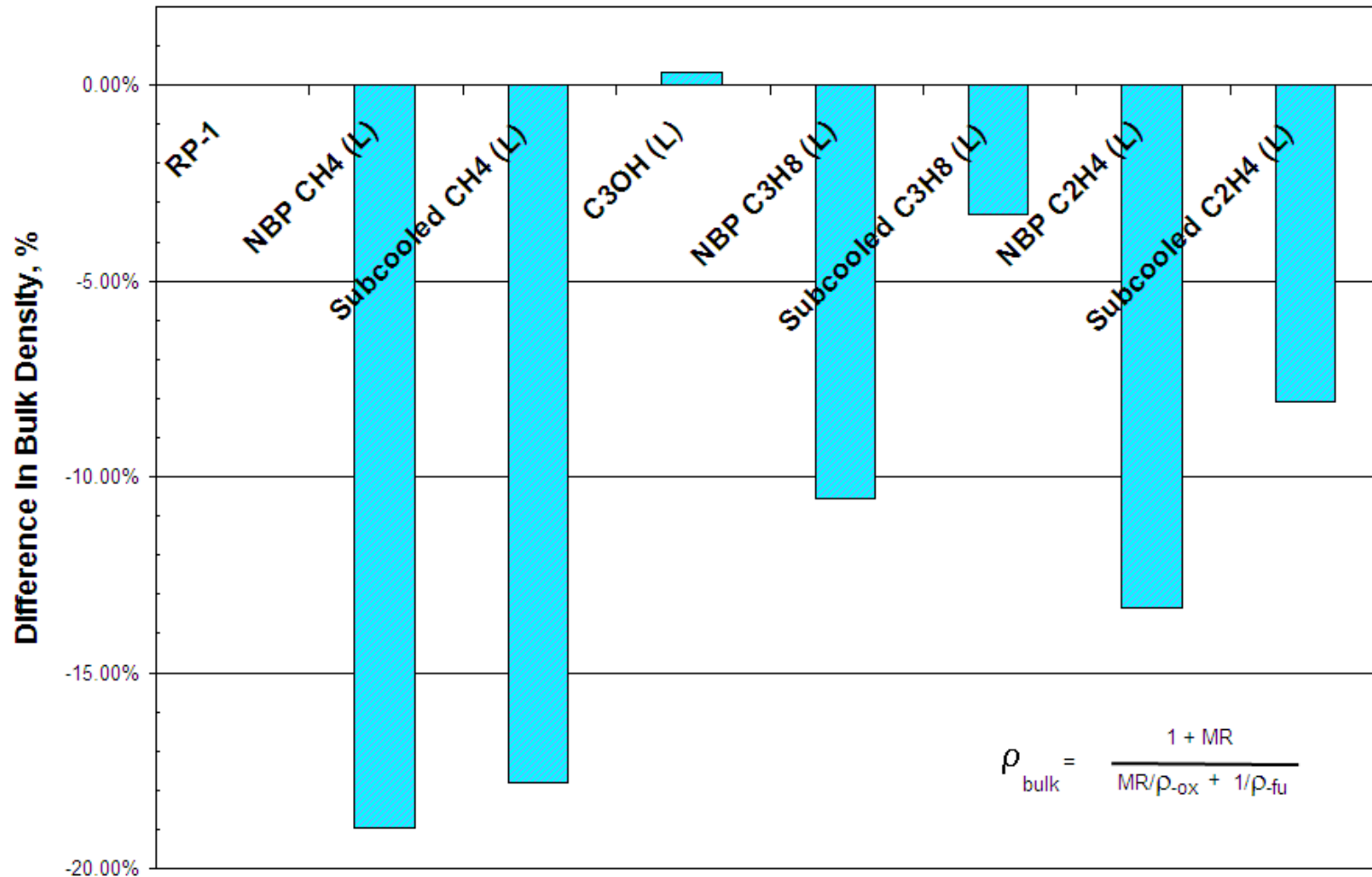

Vehicle Analysis

- **Figure of Merit (FOM) = Minimum Combined Propellant Tank Volume**
 - ❑ Minimum Tank Volumes = Smaller Spacecraft Size for Launch Vehicles
 - ❑ Lower Vehicle Dry Weight

Start with the Rocket Equation

$$\Delta V_i = I_{sp} * g_0 * \text{LN} \{ W\text{-initial} / W\text{-final} \}$$

$$\text{Vol-propellant} \sim \frac{\text{EXP} \{ \Delta V_i / I_{sp} * g_0 \} - 1}{\rho_{\text{bulk}}}$$

Where $\rho_{\text{bulk}} = \frac{1 + \text{MR}}{\text{MR} / \rho_{\text{-oxidizer}} + 1 / \rho_{\text{-fuel}}}$

Propellant Tank Volume Comparison for Lander / Ascent Vehicles

Propellant Tank Volume Comparison with LOX/Methane System

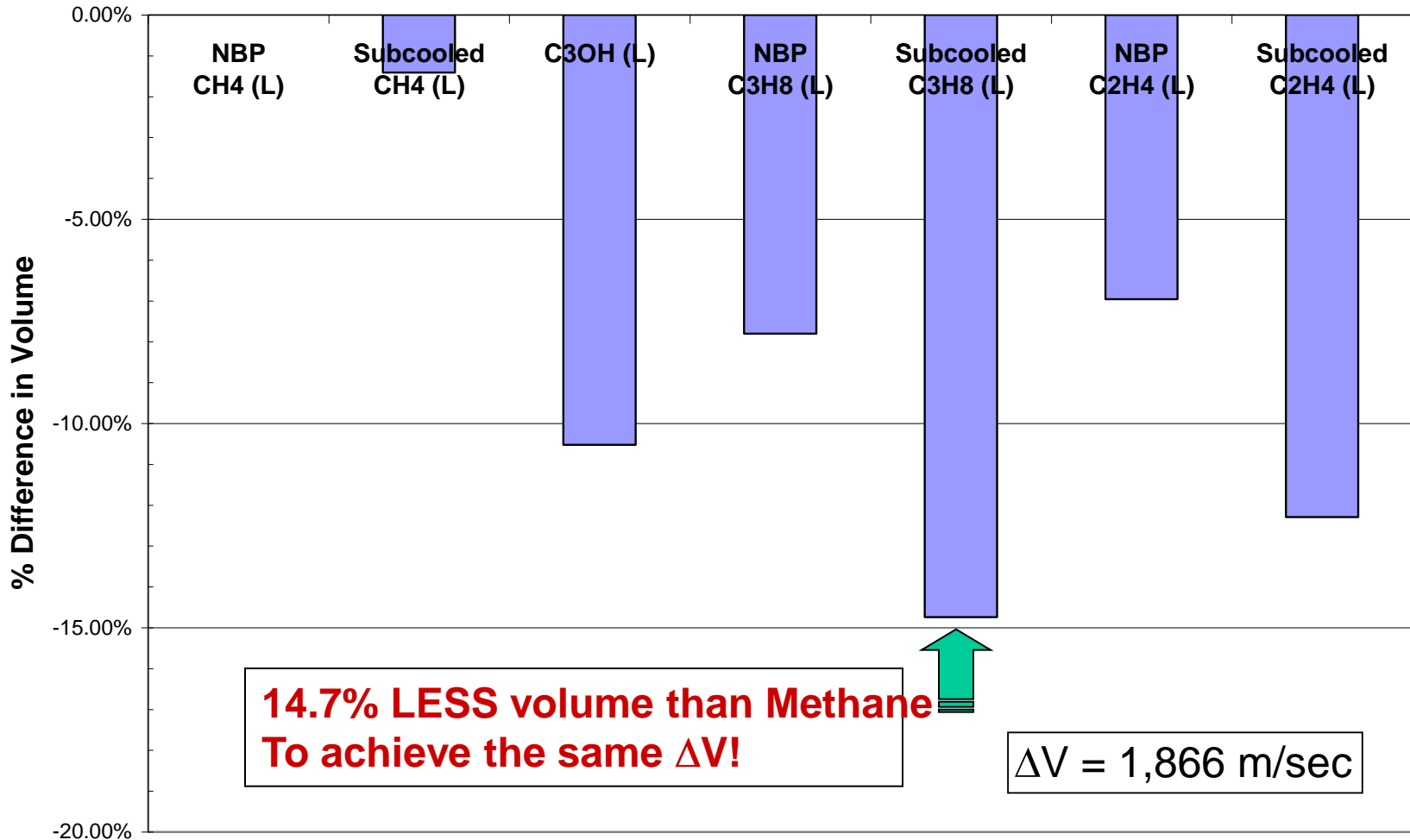

Propellant Tank Volume Comparison for In-Space Propulsion Stages

Propellant Tank Volume Comparison with LOX/Methane System

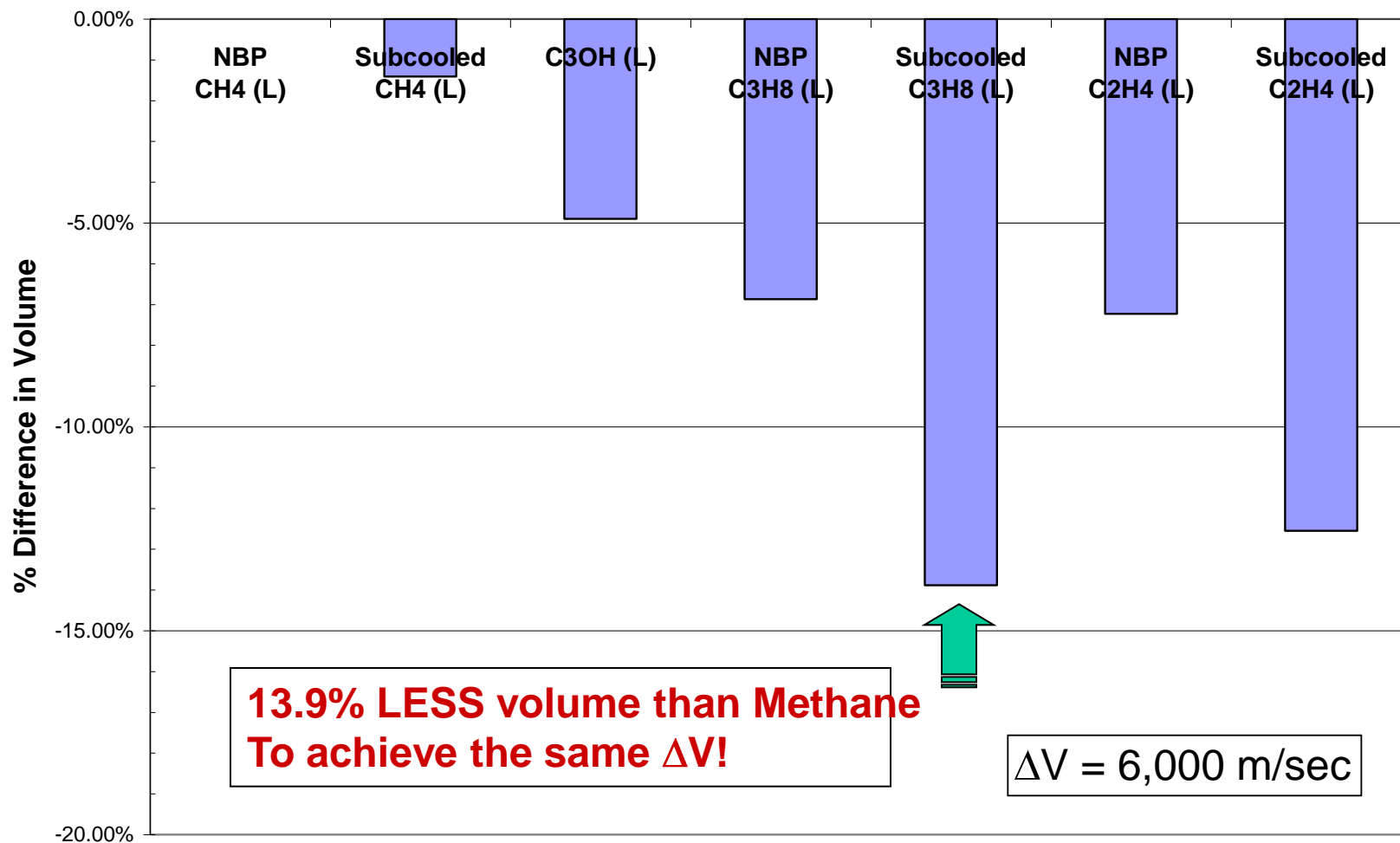

Hydrogen Tank Volume Comparison for Lander / Ascent Vehicles

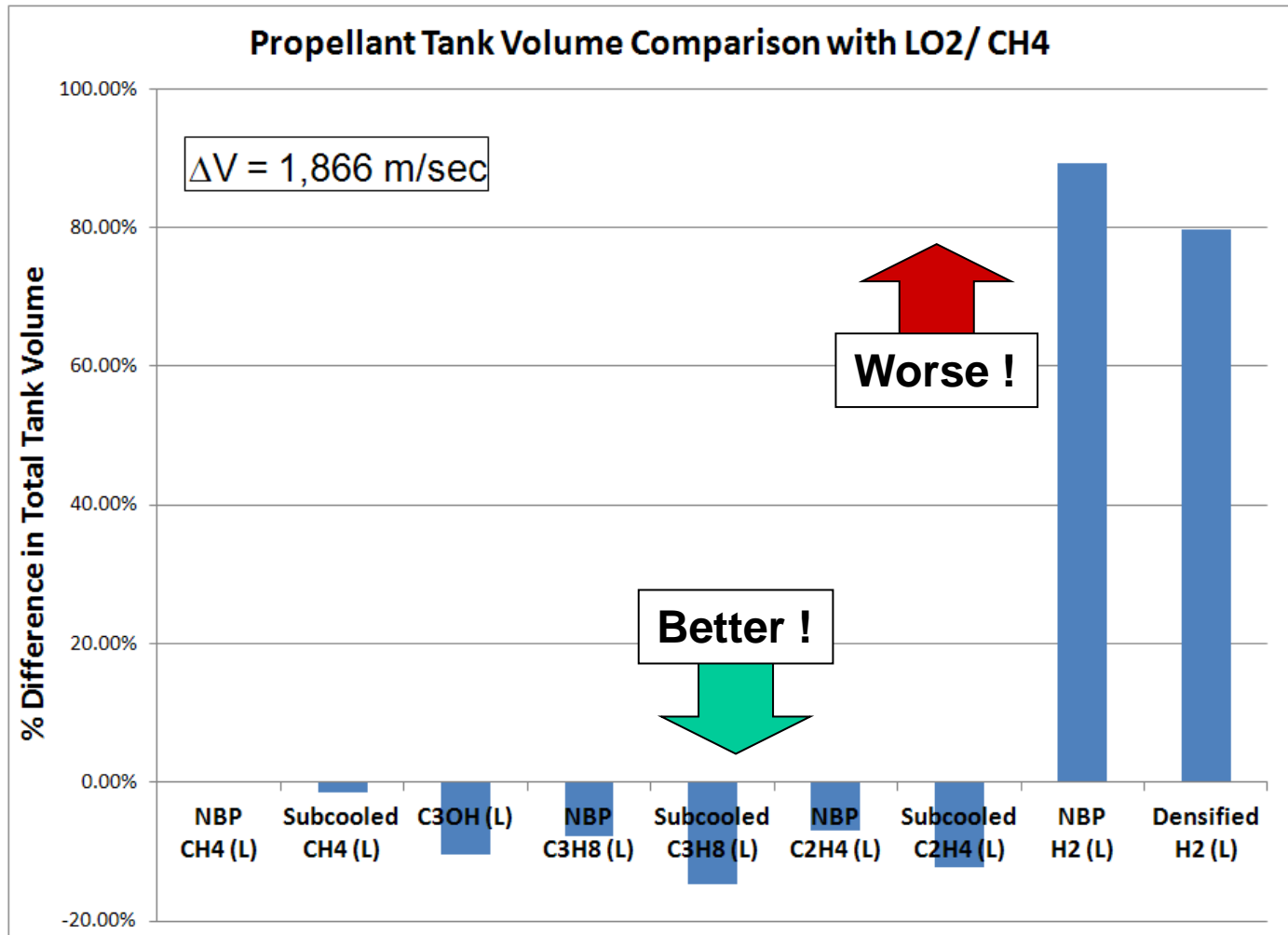

Hydrogen Tank Volume Comparison for In-Space Propulsion Stages

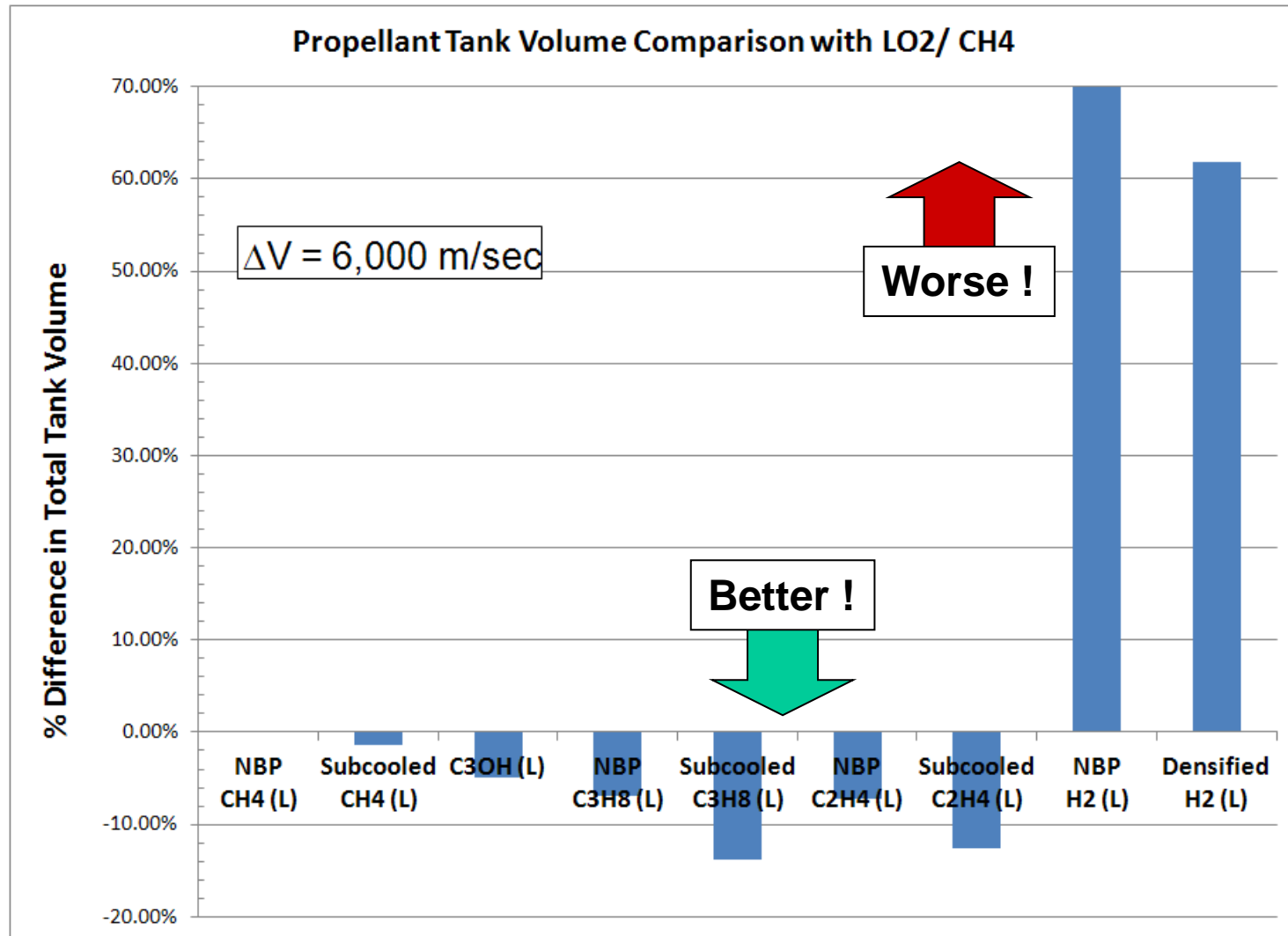



***Chemistry
of
Synthetic Fuels and
Chemicals Production***

Synthetic Fuels and Chemicals Production

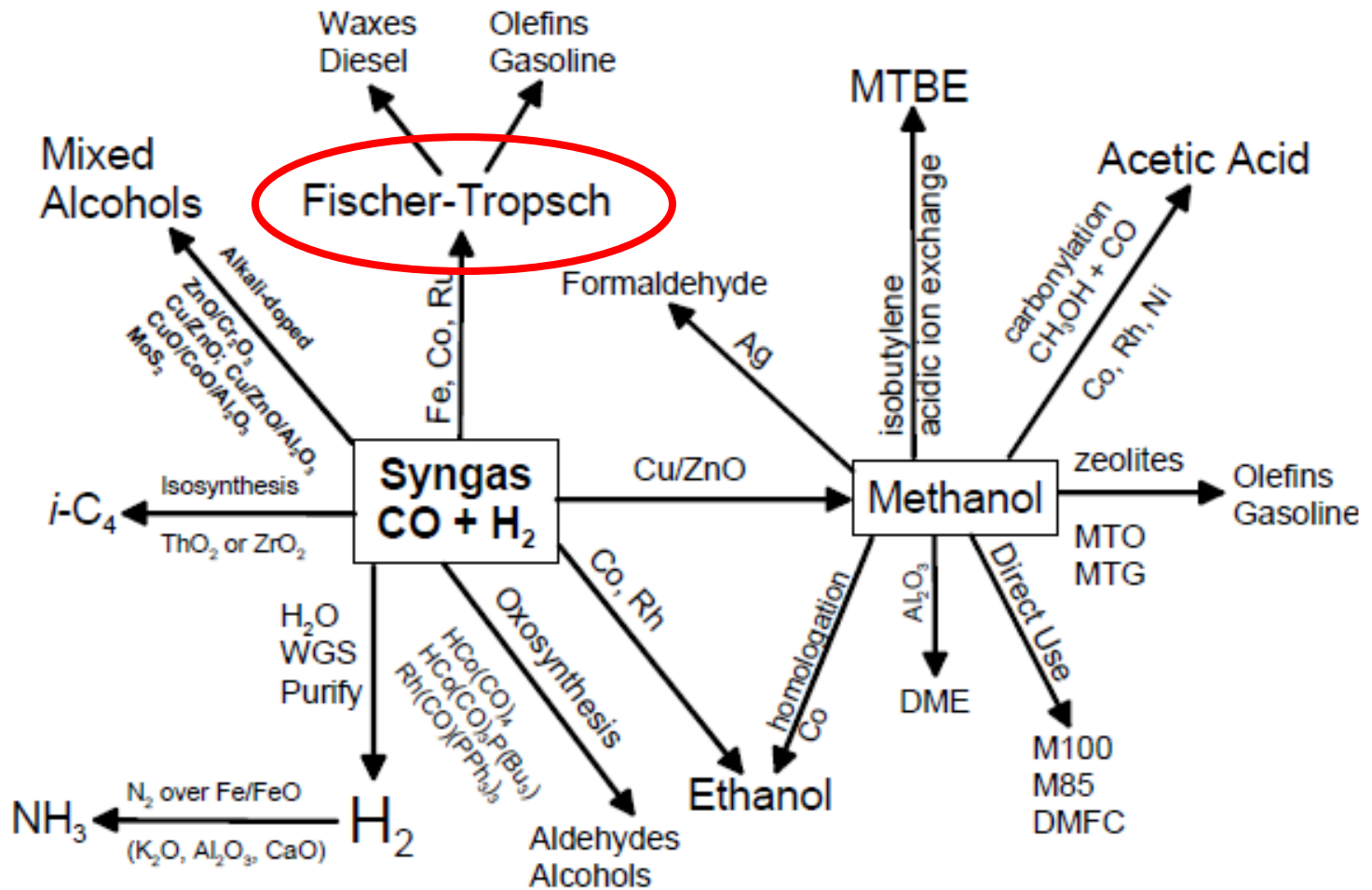

National Renewal Energy Laboratory
NREL report NREL/TP-510-34929, December 2003

Fischer-Tropsch Synthesis

- **Invented by Franz Fischer and Hans Tropsch in 1920s**
- **Used by Germany and Japan during WW-II to produce synthetic fuels to power its military and industry energy needs**
 - ❑ more than 124,000 barrels per day from 25 plants ~ 6.5 million tons in 1944*
- **South Africa synthetic fuel (diesel) production**
 - ❑ Sasol I in 1955 convert Coal to synthetic fuel
 - ❑ Sasol II (1980) and Sasol III (1982)
- **Current Productions**
 - ❑ Bintuli, Malaysia (1993) by Shell
 - ❑ Syntroleum, Australia (10,000 barrels per day)
- **FTS propellant production eliminate sulfur as contaminants**
 - ❑ Sulfur has been identified as key to fuel fouling in engine cooling

* http://en.wikipedia.org/wiki/Fischer-Tropsch_process

<http://www.fischer-tropsch.org/>

Specific Fischer-Tropsch Synthesis (FTS) Chemistry*

Methane (Sabatier Reaction)

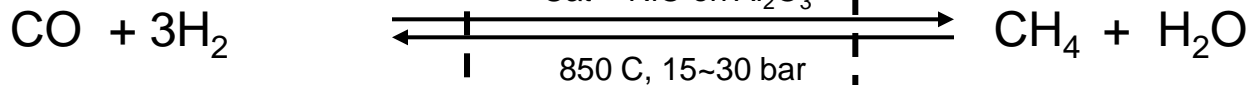

Paraffin⁺

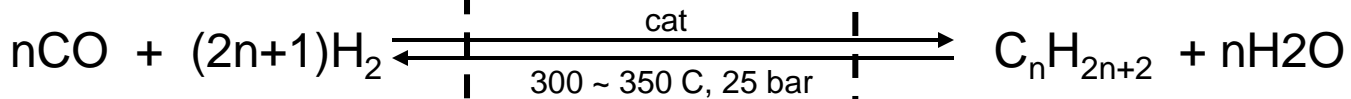

Olefin⁺

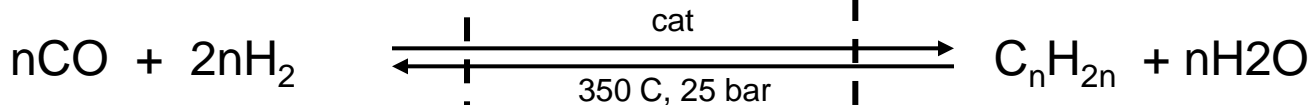

Alcohol

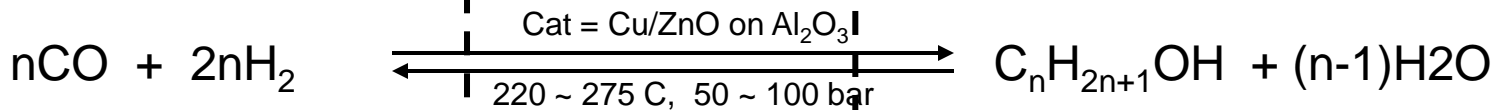

+ Catalyst options in decreasing order of activity: Ru > Fe > Ni > Co > Rh > Pd > Pt.

CO production

- reverse water-gas-shift (RWGS) reaction

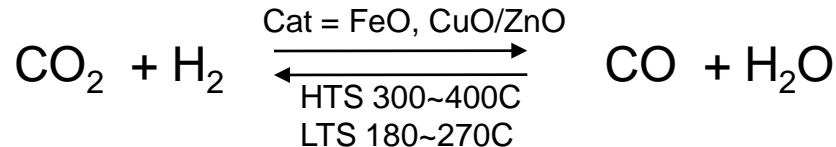

* Spath and Dayton, National Renewable Energy Laboratory, NREL/TP-510-34929, December 2003

Synthetic Propane Production

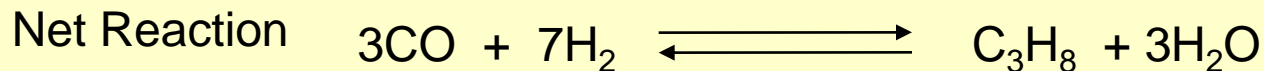
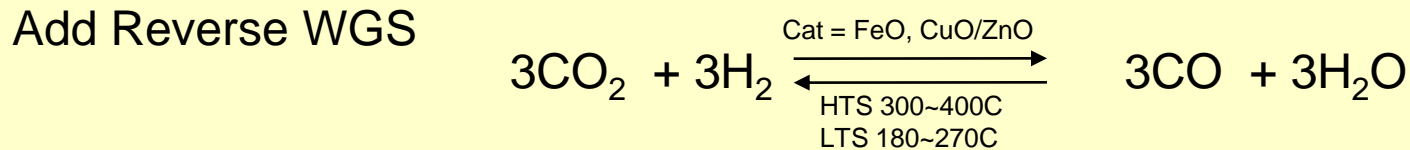
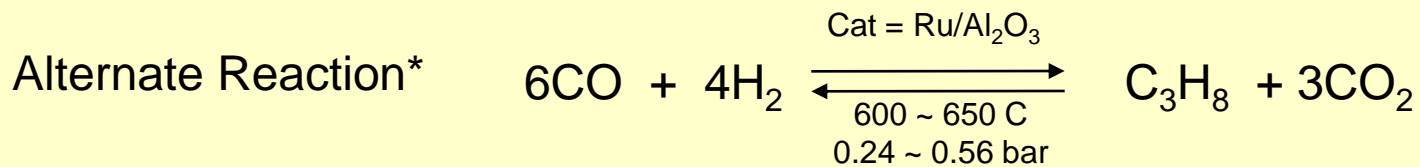
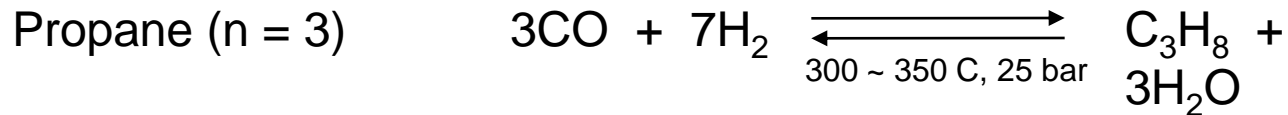
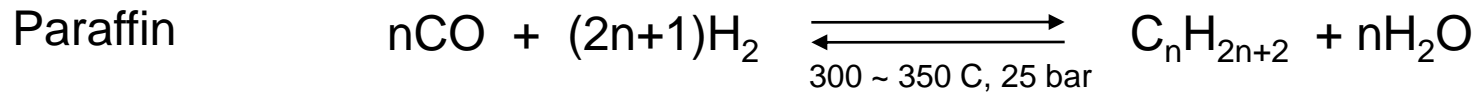

* Sutton, Moisan and Ross "Kinetic study of CO₂ reforming of propane over Ru/Al₂O₃", Catalysis Letters Vol. 75, No. 3–4, 2001

Mars ISRU Propellant Production Process Flow

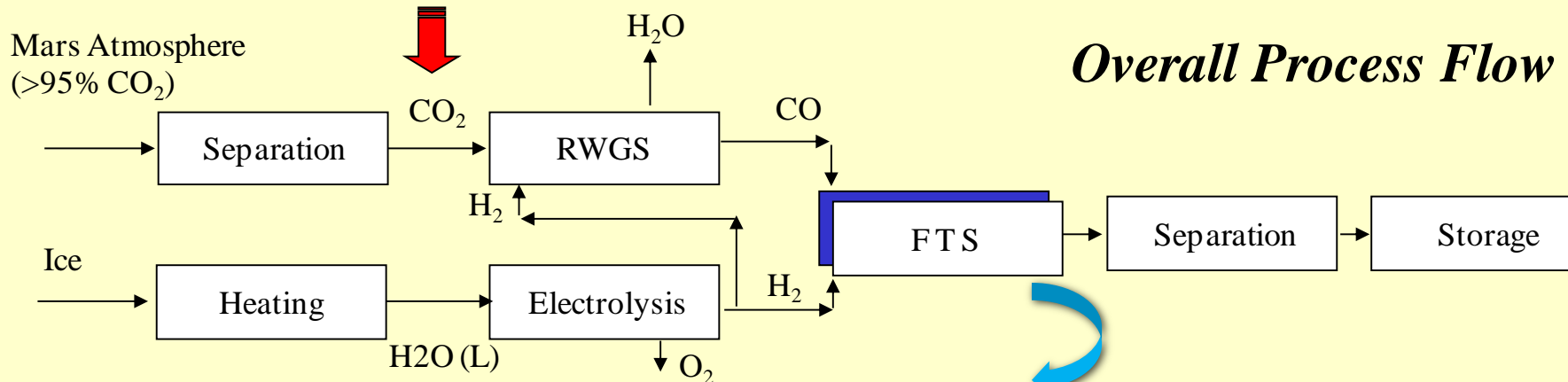

FTS Reactor can be tailored for different propellant production

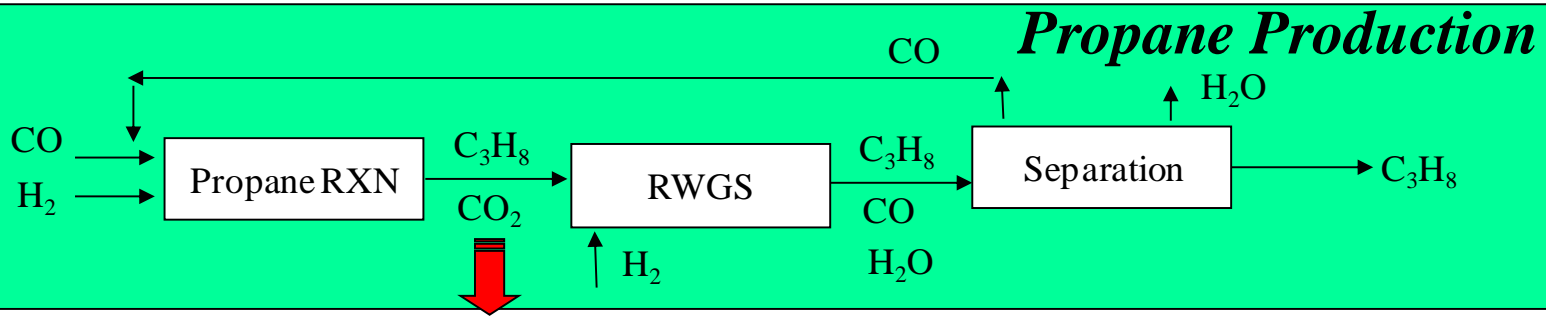
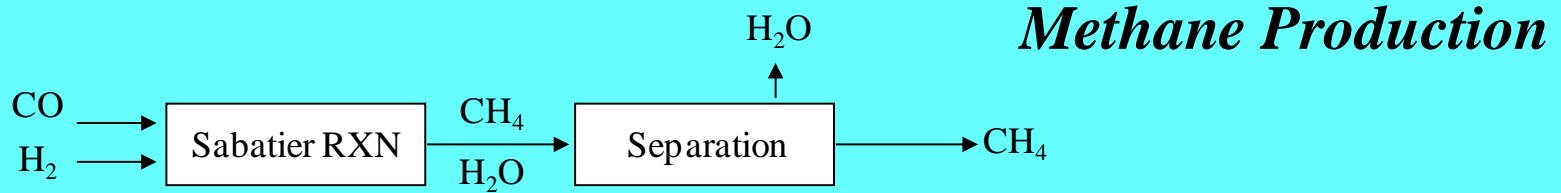

Summary

- **Human Space Exploration to Mars requires that we have a different Concept of Operation**
 - ❑ In-Situ Resource Utilization (ISRU) reduces Exploration Vehicles size
- **Vehicle System Analysis conducted to identify candidate ISRU propellants**
 - ❑ Engine Isp is not the only Figure of Merit (FOM) in propellant selection
 - Liquid Hydrogen (LH2) will require 60% (subcooled LH2) to 70% (NBP LH2) HIGHER tank volume than Methane (CH4) for the same ΔV requirement
 - ❑ Propellant(s) that meet mission performance while offer lowest vehicle tank volume and producible via the ISRU method
 - Combined vehicle Isp and low propellant density
 - ❑ Subcooled Propane (C3H8) provides a 14% LESS tank volume than CH4 for the same vehicle ΔV performance requirement
- **Synthetic Fuel Technology exist for ISRU propellant manufacturing**
 - ❑ Leverage the expertise in Chemical Industry