



Application and Evaluation of Control Modes for Risk-Based Engine Performance Enhancements

Yuan Liu
N&R Engineering, Parma Heights, Ohio

Jonathan S. Litt
Glenn Research Center, Cleveland, Ohio

T. Shane Sowers
Vantage Partners, Brook Park, Ohio

A. Karl Owen
Consultant, North Royalton, Ohio

Ten-Huei Guo
Glenn Research Center, Cleveland, Ohio

NASA STI Program . . . in Profile

Since its founding, NASA has been dedicated to the advancement of aeronautics and space science. The NASA Scientific and Technical Information (STI) program plays a key part in helping NASA maintain this important role.

The NASA STI Program operates under the auspices of the Agency Chief Information Officer. It collects, organizes, provides for archiving, and disseminates NASA's STI. The NASA STI program provides access to the NASA Aeronautics and Space Database and its public interface, the NASA Technical Reports Server, thus providing one of the largest collections of aeronautical and space science STI in the world. Results are published in both non-NASA channels and by NASA in the NASA STI Report Series, which includes the following report types:

- **TECHNICAL PUBLICATION.** Reports of completed research or a major significant phase of research that present the results of NASA programs and include extensive data or theoretical analysis. Includes compilations of significant scientific and technical data and information deemed to be of continuing reference value. NASA counterpart of peer-reviewed formal professional papers but has less stringent limitations on manuscript length and extent of graphic presentations.
- **TECHNICAL MEMORANDUM.** Scientific and technical findings that are preliminary or of specialized interest, e.g., quick release reports, working papers, and bibliographies that contain minimal annotation. Does not contain extensive analysis.
- **CONTRACTOR REPORT.** Scientific and technical findings by NASA-sponsored contractors and grantees.

- **CONFERENCE PUBLICATION.** Collected papers from scientific and technical conferences, symposia, seminars, or other meetings sponsored or cosponsored by NASA.
- **SPECIAL PUBLICATION.** Scientific, technical, or historical information from NASA programs, projects, and missions, often concerned with subjects having substantial public interest.
- **TECHNICAL TRANSLATION.** English-language translations of foreign scientific and technical material pertinent to NASA's mission.

Specialized services also include organizing and publishing research results, distributing specialized research announcements and feeds, providing information desk and personal search support, and enabling data exchange services.

For more information about the NASA STI program, see the following:

- Access the NASA STI program home page at <http://www.sti.nasa.gov>
- E-mail your question to help@sti.nasa.gov
- Phone the NASA STI Information Desk at 757-864-9658
- Write to:
NASA STI Information Desk
Mail Stop 148
NASA Langley Research Center
Hampton, VA 23681-2199



Application and Evaluation of Control Modes for Risk-Based Engine Performance Enhancements

Yuan Liu
N&R Engineering, Parma Heights, Ohio

Jonathan S. Litt
Glenn Research Center, Cleveland, Ohio

T. Shane Sowers
Vantage Partners, Brook Park, Ohio

A. Karl Owen
Consultant, North Royalton, Ohio

Ten-Huei Guo
Glenn Research Center, Cleveland, Ohio

Prepared for the
50th Joint Propulsion Conference
cosponsored by AIAA, ASME, SAE, and ASEE
Cleveland, Ohio, July 28–30, 2014

National Aeronautics and
Space Administration

Glenn Research Center
Cleveland, Ohio 44135

Trade names and trademarks are used in this report for identification only. Their usage does not constitute an official endorsement, either expressed or implied, by the National Aeronautics and Space Administration.

Level of Review: This material has been technically reviewed by technical management.

Available from

NASA STI Information Desk
Mail Stop 148
NASA Langley Research Center
Hampton, VA 23681-2199

National Technical Information Service
5301 Shawnee Road
Alexandria, VA 22312

Available electronically at <http://www.sti.nasa.gov>

Application and Evaluation of Control Modes for Risk-Based Engine Performance Enhancements

Yuan Liu
N&R Engineering
Parma Heights, Ohio 44130

Jonathan S. Litt
National Aeronautics and Space Administration
Glenn Research Center
Cleveland, Ohio 44135

T. Shane Sowers
Vantage Partners, LLC
Brook Park, Ohio 44142

A. Karl Owen
Consultant
North Royalton, Ohio 44133

Ten-Huei Guo
National Aeronautics and Space Administration
Glenn Research Center
Cleveland, Ohio 44135

Abstract

The engine control system for civil transport aircraft imposes operational limits on the propulsion system to ensure compliance with safety standards. However, during certain emergency situations, aircraft survivability may benefit from engine performance beyond its normal limits despite the increased risk of failure. Accordingly, control modes were developed to improve the maximum thrust output and responsiveness of a generic high-bypass turbofan engine. The algorithms were designed such that the enhanced performance would always constitute an elevation in failure risk to a consistent predefined likelihood. This paper presents an application of these risk-based control modes to a combined engine/aircraft model. Through computer and piloted simulation tests, the aim is to present a notional implementation of these modes, evaluate their effects on a generic airframe, and demonstrate their usefulness during emergency flight situations. Results show that minimal control effort is required to compensate for the changes in flight dynamics due to control mode activation. The benefits gained from enhanced engine performance for various runway incursion scenarios are investigated. Finally, the control modes are shown to protect against potential instabilities during propulsion-only flight where all aircraft control surfaces are inoperable.

Nomenclature

Alt	altitude
C-MAPSS40k	Commercial Modular Aero-Propulsion System Simulation 40k
EOL	end-of-life
EPR	engine pressure ratio
FAA	Federal Aviation Administration

FADEC	full authority digital engine control
FPA	flight path angle
FR	faster response
Hdg	heading
HPC	high-pressure compressor
HPT	high-pressure turbine
NASA	National Aeronautics and Space Administration
OT	overthrust
PCA	propulsion controlled aircraft
PIO	pilot-induced oscillation
PLA	power lever angle
P_{s30}	combustor static pressure
T_{48}	high-pressure turbine exit total temperature
TO	takeoff
TCM	Transport Class Model
VBV	variable bleed valve
VSV	variable stator vane
γ	flight path angle
ϕ	roll angle

1.0 Introduction

The performance of propulsion systems used on modern civil transport aircraft is generally limited by mandatory adherence to safety standards set by regulatory bodies such as the Federal Aviation Administration (FAA). Limits placed on operating parameters such as spool speeds and gas temperatures serve to minimize the probability of engine failure but also represent a ceiling on performance capabilities such as thrust production and responsiveness. However, this prioritization may not be optimal during certain emergency scenarios. Namely, maximizing the chance of survival may require accepting a higher risk of engine failure (Ref. 1).

Numerous studies have been conducted into the possibility, benefits, and risks of pushing engine performance beyond maximum design limits. Recent examples of such efforts include applying sliding mode controllers (Ref. 2) and L_1 adaptive control theory (Ref. 3) to improve dynamic engine response. Researchers at the National Aeronautics and Space Administration (NASA) have developed control modes that extract greater thrust output (overthrust mode) and improve thrust responsiveness to throttle commands (faster response mode) with an emphasis on minimizing changes to the conventional engine control architecture (Refs. 4 and 5). Studies have also outlined the benefits of enhancing maximum engine performance, particularly with respect to directional stability and control for a damaged aircraft (Refs. 6 to 9). Additional scenarios such as runway incursions and propulsion-only flight have also been evaluated via piloted simulations (Ref. 10). Investigations have also been conducted into characterizing the engine failure risk that accompanies the usage of these enhanced performance modes. Statistical methods were used to quantify the likelihood of disk and blade failure and compressor instabilities due to overthrust and faster response, respectively (Refs. 11 and 12). A recent study utilized these statistical models to redesign the NASA-developed overthrust and faster response control modes such that the enhanced performance delivered is based on the elevation of failure risk to a consistent predefined level (Ref. 13). This paper documents the continuation and application of that effort.

The objective of this paper is to present and evaluate the application of the risk-based enhanced performance control modes. A brief description of the control modes is provided in Section 2.0. The control modes were implemented in a combined engine/aircraft digital simulation and evaluated using both an autopilot flight control system and realistic flight simulator hardware operated by an experienced pilot. The engine and aircraft models are used extensively in research and well-documented (Refs. 14 and 15). Section 3.0 provides a concise overview of the computer models and the flight simulator system. Section 4.0 presents the experimental methodology and results. Using the engine/aircraft model and flight simulator system, the control modes were tested in various emergency situations to determine their effectiveness. The scenarios tested represent a range of severity. First, the effects of simply activating the control modes during steady, level flight were studied. Next, the control modes were evaluated for a runway incursion situation. Runway incursions cause a sudden reduction in available takeoff distance (Ref. 16), which additional thrust may be able to overcome. Finally, the control modes were applied to propulsion-only flight control. There have been several instances where airframe malfunction or damage caused the failure of all flight control surfaces and the crew resorted to engine thrust modulation to fly the aircraft (Refs. 17 to 19). These incidents prompted extensive research by NASA into propulsion-controlled aircraft (PCA) flight, which identified slow thrust response as a hindrance (Refs. 20 and 21). Simulation results demonstrate the benefits provided by the control modes for a propulsion-controlled aircraft.

2.0 Control Modes

Two types of engine performance enhancements are considered and evaluated in this paper; both involve modifying the control system to improve the thrust output characteristics of the engine. Overthrust (OT) refers to pushing the engine beyond its designed maximum thrust output capability. Faster response (FR) involves speeding up the dynamics of the thrust output, especially for throttle transients from low power settings (e.g., flight idle). This section briefly describes the control modes that provide these performance enhancements. The interested reader is referred to the dedicated publication for a more complete treatment (Ref. 13).

Exceeding the maximum design performance limits naturally increases the likelihood of mishap within the engine. Therefore, a basic premise for the control modes that were developed is that their design should be based on models of component failure probability. With such a model, the risk of failure can be quantified based on operating conditions whether the engine operates within or beyond its normal limits. Conversely, the extent by which engine performance may be increased can be quantified by defining a maximum allowable probability of failure. This definition also acts as the objective for the control mode design. The concept is best elucidated through examples; the following subsections describe the architecture of the OT and FR control modes.

2.1 Overthrust Mode

Increasing thrust output requires hotter gas temperatures within the engine and faster spool speeds. Thus, the design of the OT control mode was based on the risk of compressor/turbine disk failure and turbine blade failure. Under normal operation, these failure probabilities vary greatly based on factors such as engine power, health, and ambient conditions, but must remain below 10^{-5} per flight hour per regulations defined by the FAA (Ref. 22). The design objective of the OT control mode was to increase maximum thrust output such that it corresponded to a consistent risk of failure of 10^{-3} per hour.

A statistical model was used to relate the probability of failure to operating parameters such as spool speeds and gas temperatures (Ref. 11). The control mode algorithms were designed based on a simplified version of this risk model: disk failure risk was calculated as a function of core speed, and blade failure risk a function of core speed and high-pressure turbine (HPT) exit total temperature ($T48$). As such, the 10^{-3} failure rate limit can be converted to a single core speed limit for disk failure and a two-variable temperature/speed threshold for blade failure. Thus, when activated, the OT mode disables the default speed and temperature protection logic within the engine control system. During maximum overthrust, the

control mode uses feedback logic to push the operating point of the engine to the aforementioned disk and blade failure thresholds, stopping at whichever limit is reached first. Reproduced from Reference 13, Figure 1 compares the probability of blade failure with overthrust against that with maximum baseline thrust for 180 different flight and engine health conditions. Figure 2 plots the HPT exit temperatures and core speeds of the same 180 overthrust cases with a threshold representing the 10^{-3} blade failure risk. In general, the OT mode consistently increases the failure risk to the desired elevated failure rate limit by driving the engine to the temperature/speed threshold. The hollow points in both figures represent conditions where a combustor static pressure (P_{s30}) limit, which was not bypassed, was reached before the risk threshold. Increases in the net thrust output for the 180 cases ranged from 10 to 25 percent over the maximum design level.

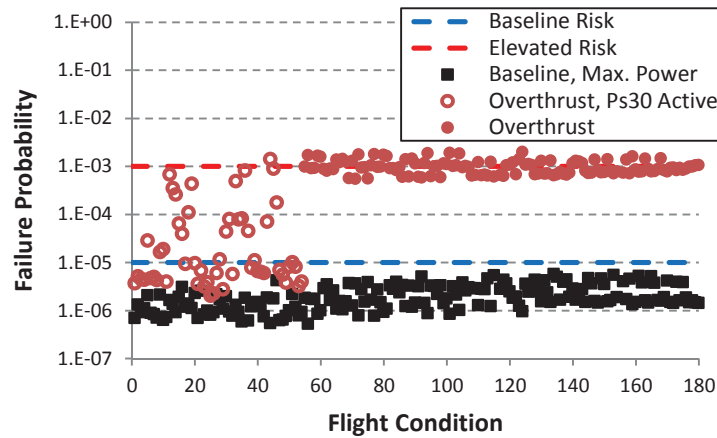

Figure 1.—Overthrust operation at various flight conditions. OT control mode increases maximum thrust output until a predefined failure probability unless maximum combustor pressure limit was reached.

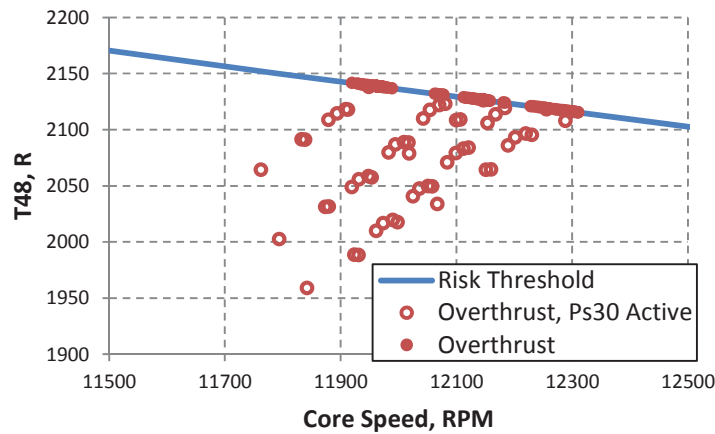

Figure 2.—Values of HPT exit temperature and core speed during overthrust operation at various flight conditions. Maximum combustor pressure limit prevents operating on the desired risk threshold for certain conditions.

2.2 Faster Response Mode

When considering improvements in transient thrust response, the primary risk is usually high-pressure compressor (HPC) stall. Thus, the design of the FR control mode required a method to determine the probability of HPC stall during engine operation. Details of this stall risk calculation are available in Reference 13. Essentially, the process involved attaching an uncertainty element due to engine-to-engine variation to the stall margin output values from any deterministic compressor or engine simulation. This uncertainty was modeled using a statistical compressor stability stack-up, letting the deterministic simulation represent the mean of an engine fleet (Ref. 23). The result was a function that related the mean stall margin to the probability of stall stemming from engine-to-engine variation. This relationship (Figure 3, reproduced from Ref. 13) was used to guide the faster response mode design. Namely, the control mode objective was to shorten the thrust response time of the engine up to a certain allowable probability of stall. This limit was notionally set to 10^{-3} , which corresponds to a mean stall margin of approximately 2.3 percent.

The control mode design process employed several previously developed techniques to achieve faster thrust response (Refs. 4 and 5). First, the bandwidth of the primary fuel controller was increased to improve thrust response for relatively small throttle movements. Next, the customer bleed and HPC stator vane control schedules were modified to increase spool speeds at idle engine power. Finally, the acceleration control schedule was modified to allow the HPC to attain lower stall margins during large transients. Specifically, a new schedule was developed such that the minimum transient HPC stall margin would be approximately 2.3 percent for a wide range of operating conditions (Ref. 13). Figure 4 compares the minimum HPC stall margin attained during large throttle transients at 540 different flight and engine health conditions. Power transients using the baseline engine resulted in a large scatter of minimum stall margin values. With the faster response mode active, the minimum stall margin values—and hence, the probability of stall—were collapsed to a relatively consistent level for all operating conditions. Reductions in the time required for the idle-to-full-power transient generally ranged from 5 to 20 percent.

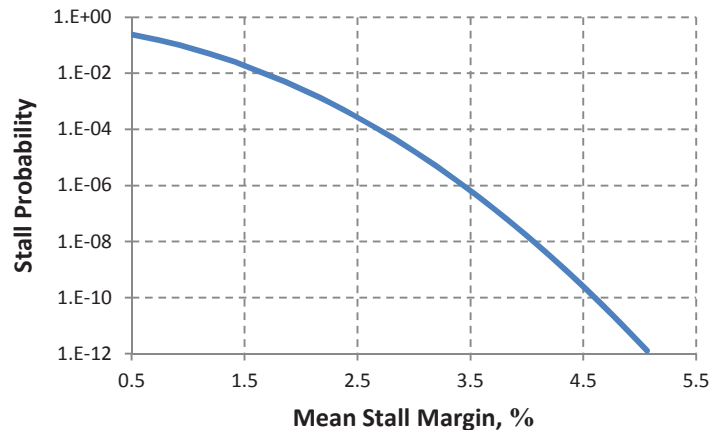

Figure 3.—Relationship to determine probability of stall due to engine-to-engine variation when using a deterministic compressor/engine model.

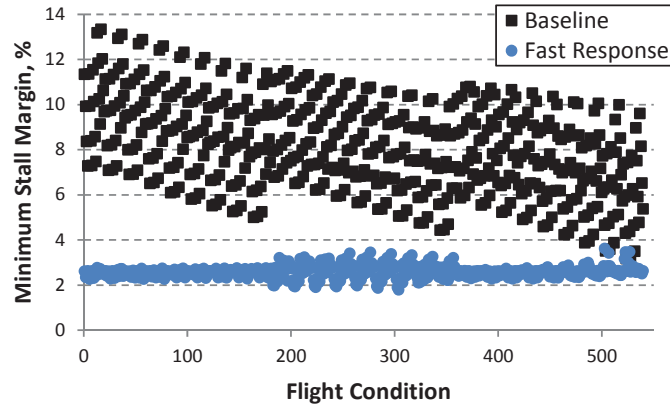

Figure 4.—Minimum HPC stall margin attained during large throttle transients at various operating conditions.

3.0 Simulations and Test Bed

This section provides brief descriptions of the aircraft model, engine model, and the flight simulation test bed used to evaluate the performance enhancing control modes.

3.1 Engine Simulation

The control modes were applied to an engine simulation called the Commercial Modular Aero-Propulsion System Simulation 40k (C-MAPSS40k) (Ref. 14). Developed by NASA Glenn Research Center, C-MAPSS40k is a nonlinear dynamic model of a generic, high-bypass, dual-spool turbofan engine with a design thrust capability of approximately 40,000 lb. The overall engine simulation, which is written in a combination of MATLAB/Simulink (The Mathworks, Inc.) and C, is a modular interconnection of models representing major engine components such as the inlet, fan, compressors, combustor, turbines, and nozzles. The control inputs to the engine—fuel flow rate, variable stator vane (VSV) setting, and variable bleed valve (VBV) setting—are calculated by a comprehensive gain-scheduled feedback control system representative of the Full Authority Digital Engine Control (FADEC) systems used on modern transport aircraft (Ref. 24). The control system utilizes sensed engine information—engine simulation output parameters processed by models that emulate sensor noise and dynamics. VSV and VBV commands are scheduled on spool speeds and inlet conditions. Fuel flow rate is calculated by gain-scheduled feedback control on engine pressure ratio (EPR). The fuel flow command is passed through a suite of limit protection controllers to prevent compressor stall and excursions beyond allowable speed, temperature, and pressure thresholds. The control commands are processed by actuator models that ensure the engine receives realistic input values.

3.2 Aircraft Simulation

A modified version of the Transport Class Model (TCM) (Ref. 15) was selected as the airframe simulation. Developed for controls research by NASA Langley Research Center, the TCM is a dynamic simulation of a modern, mid-sized, narrow-body, twin-engine, commercial transport aircraft implemented in the MATLAB/Simulink environment. The aircraft aerodynamic characteristics evolved from wind-tunnel testing of a 5.5 percent sub-scale model of a transport aircraft. The hypothetical, full-scale airframe that the TCM represents weighs 185,000 lb and has a wing area of 1,951 ft² and wing span of 125 ft. The simulation also contains models of the control surface actuators to capture realistic response times and nonlinearities. The default propulsion systems within the TCM were replaced by two copies of the C-MAPSS40k turbofan engine model. The control system for each C-MAPSS40k engine was augmented with the overthrust and faster response control modes.

The TCM version used for this work also includes an autopilot-like flight control system that allows the user to easily execute any desired flight profile. The control system calculates the control surface deflections (e.g., elevator, aileron, etc.) and engine throttle positions required to meet air speed, altitude, and heading demands. The air speed controller (“auto-throttle”) is a feedback control system that automatically adjusts the engine throttle settings. The altitude controller consists of several nested feedback loops: the altitude feedback loop calls a flight path angle controller, which itself calls a pitch angle controller that calculates elevator deflection. Likewise, heading control is accomplished by calling a roll angle controller that calculates aileron deflection. These flight control algorithms are leveraged to demonstrate the benefits of enhanced engine performance.

3.3 Flight Simulator

A commercially available, self-contained flight simulator was used to obtain piloted evaluations of the control modes. The flight simulator system (Figure 5)—the Modular Flight Deck developed by Precision Flight Controls, Inc.—is a realistic two-seater cockpit that includes pilot and co-pilot yoke and pedal controls, throttle quadrant, three interior computer screens to simulate instrumentation, and five exterior high-definition screens for visualization. By default, this flight simulation system utilizes the X-Plane software (Ref. 25) for both flight dynamics and graphical rendering. For this application, however, the combined TCM/C-MAPSS40k model is used to drive the physics of the flight simulator, with X-Plane handling visualization only.



Figure 5.—Interior view of flight simulation test bed for piloted evaluations.

4.0 Application and Evaluation

In order to evaluate the effects and benefits of the control modes, several simulation experiments were conducted using the TCM/C-MAPSS40k model and flight simulator system. The experiments fall into three categories: control mode activation, runway incursion, and propulsion-only flight. All three scenarios were simulated using the aforementioned TCM flight control system without human pilot input. This was to ensure consistency across all test cases for proper assessment of the control modes. In addition, piloted evaluations using the flight simulator hardware were performed for the propulsion-only scenario.

4.1 Control Mode Activation

A single switch was used to simultaneously activate both enhanced performance control modes. In the flight simulator, this switch is located on a custom overhead panel in the cockpit. The signal from this switch is linked to a flag variable within the engine control system that triggers both control modes. For the non-piloted computer simulation cases, this flag variable was manipulated directly. Once online, the faster response control mode increases thrust responsiveness to throttle movement for both small and large transients. The OT mode, though active, requests overthrust only when throttle position is near the top portion of its range of motion. The assumption is that if OT mode is active but the throttle position is not fully pushed forward, the pilot does not require OT and/or prefers OT to be readily available on standby.

The above implementation also ensures that activating but not yet utilizing the control modes causes minimal disturbance to the flight parameters. In other words, pilot effort required to return the aircraft to its state prior to mode activation should be small to none. To examine this scenario, the TCM flight control system was used to execute a standard descent trajectory. The aircraft was commanded to descend wings-level from 5,000 ft at -3° flight path angle and 135 kts. At 2,000 ft, the overthrust and faster response modes were activated but the descent profile remained unchanged. These conditions represent a situation where enhanced engine performance could potentially be desirable. The aircraft is in a low-energy state (altitude, speed, power) and any emergency resulting in an aborted landing would likely require a rapid increase in engine power.

Figure 6 and Figure 7 present the time histories of several engine and aircraft parameters of interest, respectively, for a 200-sec window during the descent. The flight control system calculated the elevator and throttle inputs required to maintain a steady descent. The small oscillations present in the engine parameters (thrust and core speed) result from a numerical instability of the C-MAPSS40k engine simulation at low power settings. As shown by the time traces of altitude and air speed, the frequency and magnitude of these oscillations are not significant enough to affect the aircraft flight dynamics. The performance enhancing control modes were activated at 2,000 ft altitude, indicated by the red line on the throttle plot. Since the engine was operating at low-power settings, the OT mode had no effect on engine performance. The faster response mode commanded an offset to the scheduled HPC VSV position. As previously mentioned, this action increases spool speeds without appreciably impacting the thrust output beyond a brief transitional oscillation. As a result, the effect of mode activation on the aircraft flight dynamics is nearly imperceptible.

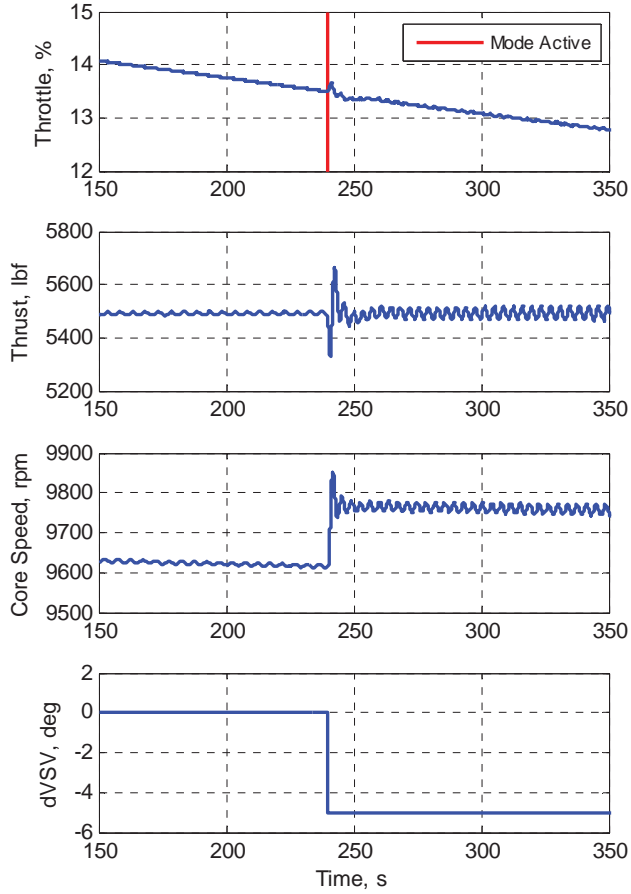

Figure 6.—Effects of control mode activation on engine parameters.

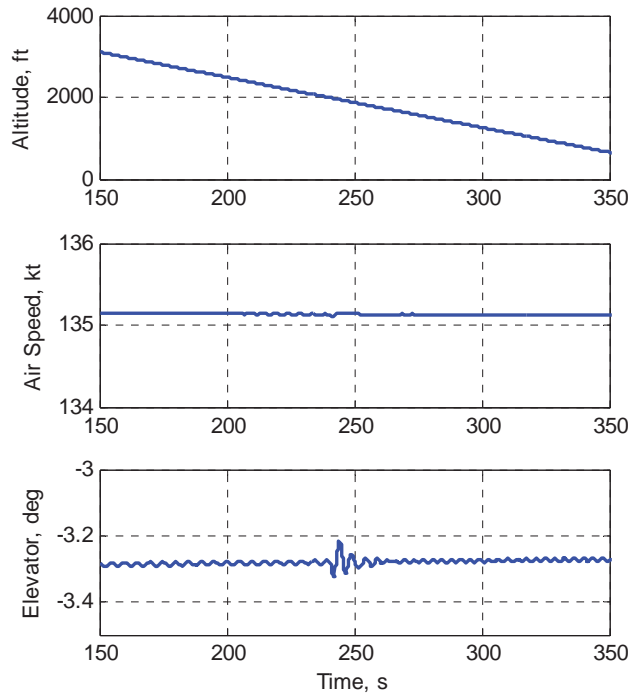

Figure 7.—Effects of control mode activation on flight parameters.

4.2 Runway Incursion

Runway incursion simulations were conducted to evaluate the effectiveness of the control modes during an emergency situation. It was expected that the extra thrust delivered by the OT mode would result in shorter takeoff (TO) distances. A total of 24 TO cases were simulated. Figure 8 summarizes the key characteristics common to all TO simulations. For each case, the aircraft was positioned stationary at x_0 with TO flap positions, and engine throttles were increased from 0 to 90 percent. To simulate visual detection of an incursion, 100 percent throttle and 20° pitch up were commanded at some distance down the runway (x_P). The distance at which the aircraft cleared an altitude of 50 ft (x_C) was then recorded. This procedure was executed for six different values of x_P with the baseline engine controller with no enhanced performance modes. To ascertain the benefits of using the enhanced performance control modes, these runs were repeated with the additional step of activating the control modes at x_P (full throttle would, therefore, correspond to maximum overthrust). Additionally, this suite of baseline and enhanced performance simulations were carried out using both new (50-hr) and end-of-life (EOL) engines, by appropriately setting the deterioration level option within the C-MAPSS40k engine model, for the total of 24 TO runs.

In order to examine in detail the relevant engine and flight parameters during a representative TO incursion run, we consider the case where x_P equals 1,500 ft. In this case, an incursion was detected when the aircraft was 1,500 ft into the TO ground roll, at which point the throttles were increased from 90 to 100 percent and the flight control system issued the appropriate elevator command to attempt to pitch the vehicle up to 20° . For the enhanced performance cases, mode activation occurred at this time as well. The variations in altitude, air speed, net thrust (both engines), exhaust gas temperature (EGT), and high-pressure compressor stall margin throughout the TO run are shown in Figure 9. For all cases, the aircraft remains on the ground for at least 500 ft beyond x_P before it gains enough air speed to take off. The distance required to take off and climb to 50 ft (x_C) increases with declining engine health. In this case, this relationship is due to a maximum limit of 1,500 R imposed on the EGT of the baseline engines in order to comply with FAA failure risk requirements. As an engine ages, producing consistent thrust levels results in a higher EGT due to decreasing component efficiencies. As Figure 9 shows, the EGT of the baseline EOL engine was already near the 1,500 R limit at 90 percent throttle, before the incursion. Therefore, unlike the new engine, increasing throttle to 100 percent does not have a significant effect on thrust output. Usage of the OT mode, however, shortened x_C by approximately 150 ft regardless of the engine health condition. In fact, x_C for an EOL engine with OT is slightly shorter than that of a new baseline engine. None of the incursion cases posed a risk of compressor stall since the transient from 90 percent to full power, though fast, was relatively small.

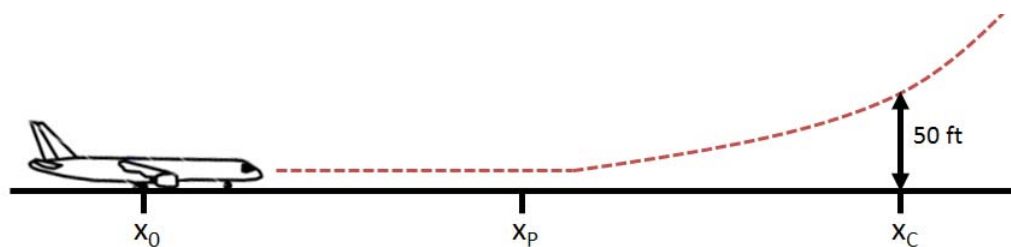

Figure 8.—Runway incursion scenario. Aircraft is stationary at x_0 . Maximum engine power and 20° pitch up command occurs at x_P . Aircraft clears 50 ft altitude at x_C .

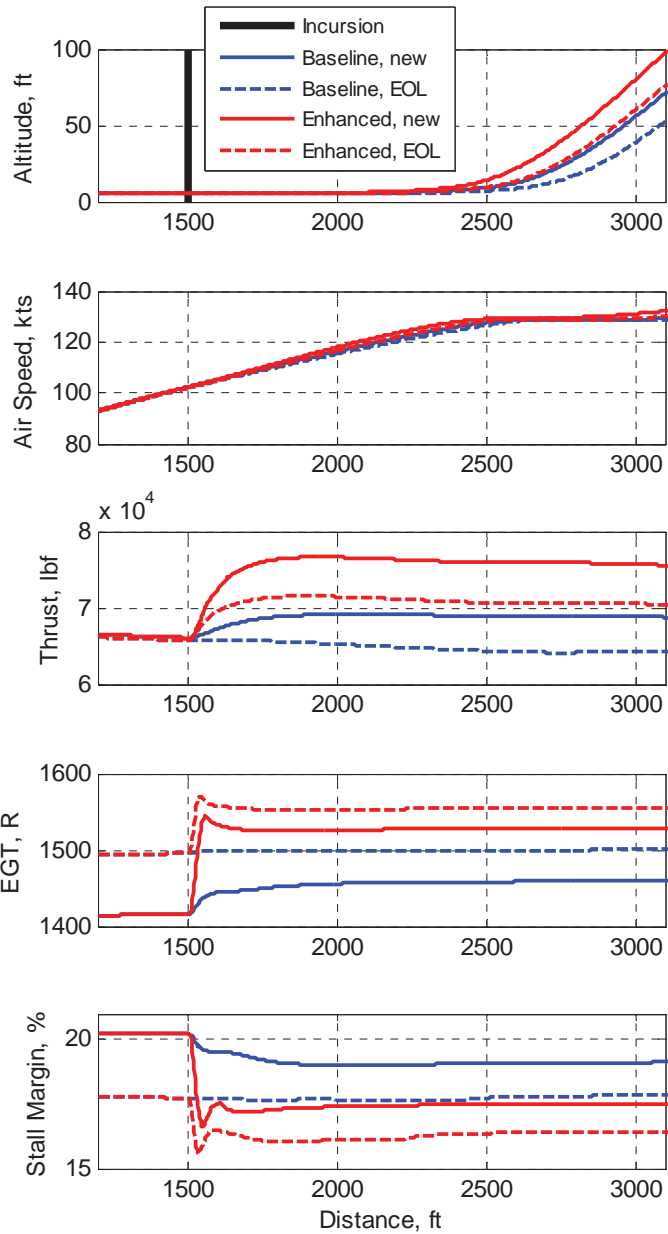

Figure 9.—Aircraft and engine parameters during an example incursion simulation (x_P equals 1,500 ft) for baseline and enhanced performance cases.

The improvement provided by the OT mode is possible because the conventional speed and temperature limits within the engine control system are bypassed. Instead, recall that maximum thrust output is determined by a risk threshold that is a function of core speed and HPT exit temperature ($T48$). These values, along with the risk boundary, are plotted in Figure 10 for the TO incursion simulation shown in Figure 9. The portion of each trajectory from the low-speed, low-temperature region of the graph (lower-left) up until the X marker (incursion detection) represents the initial engine spool-up from 0 to 90 percent throttle. Hence, the baseline and enhanced cases are indistinguishable since the modes had not been activated yet. The remainder of the trajectory from X onwards represents the transient from 90 to 100 percent throttle. For the baseline new engine, core speed and $T48$ increased slightly but remained well short of the risk boundary (as they should, per the normal allowance on the risk of failure). The trajectory of the baseline EOL engine beyond the 90 percent throttle point (i.e., X marker) is imperceptible due to the EGT limit. OT mode activation, however, signals the acceptance of an elevated failure risk. Thus, for both new and EOL cases, increasing throttle to maximum pushes core speed and $T48$ to the risk boundary.

The results of all 24 incursion simulations are summarized in Figure 11 and Figure 12. Figure 11 presents the relationship between the aircraft speed at x_p (where full throttle and pitch up was initially commanded) and the distance traveled from x_p to x_c (where the aircraft cleared 50 ft altitude) for all runs. With the control modes, the aircraft equipped with EOL engines was able to generally outperform that with new (baseline) engines. The difference in x_c between the baseline and enhanced performance cases is plotted in Figure 12 for both new and EOL engines. The benefits diminish as mode activation occurs at higher speeds. The aircraft configuration, and thus the minimum air speed required to take off, was identical for all runs. Hence, these results suggest the benefits provided by increased engine performance in the incursion scenario stem primarily from a faster ground acceleration to the minimum TO speed (with faster climb to 50 ft as a secondary factor).

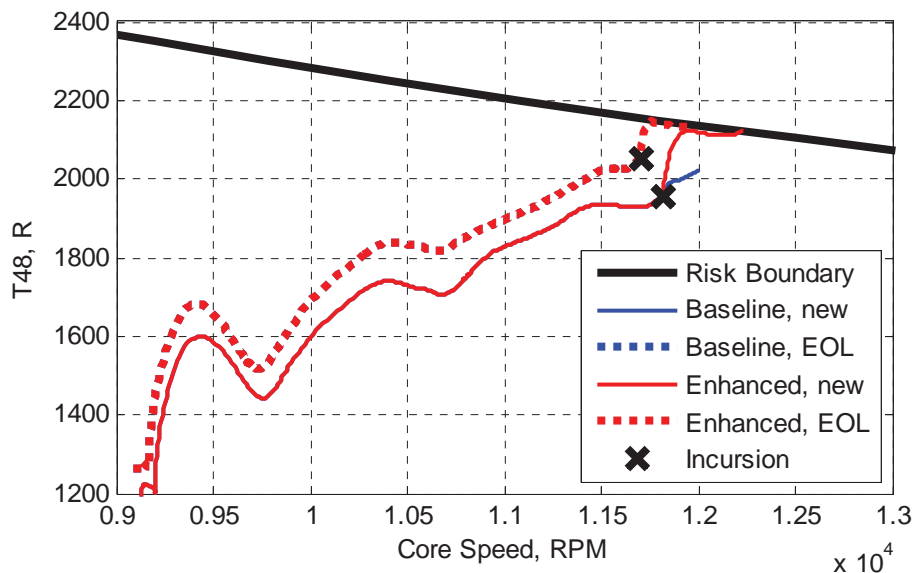

Figure 10.—Engine risk parameters relative to overthrust risk threshold during incursion simulation.

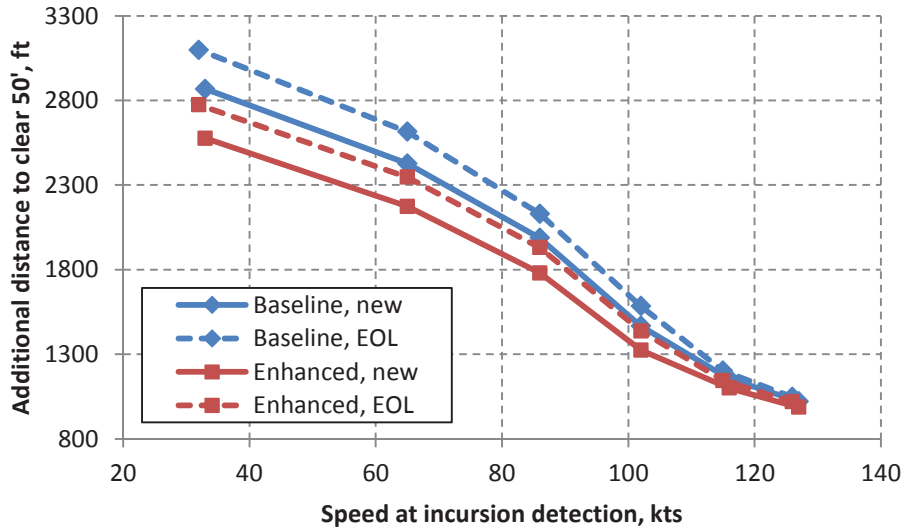

Figure 11.—Effects of engine performance enhancements on the additional distance beyond x_p needed to clear 50 ft.

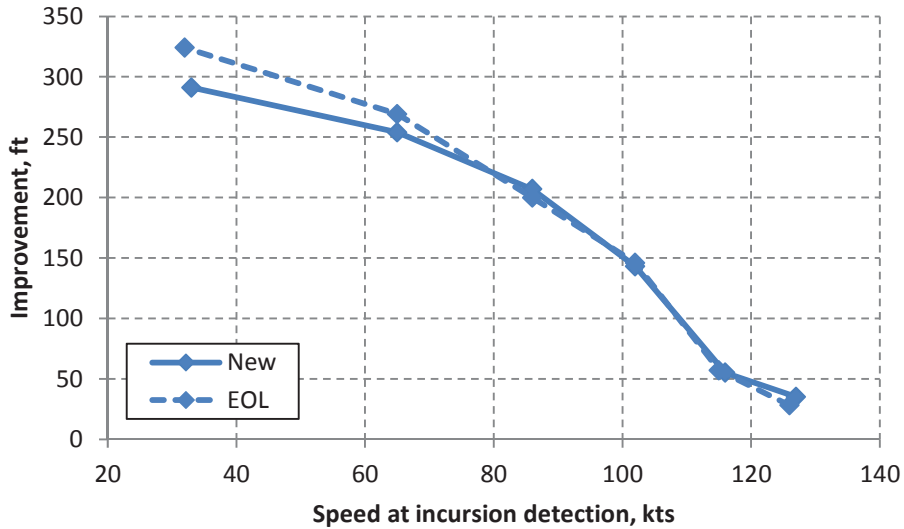

Figure 12.—Improvement in distance required to clear 50 ft due to engine performance enhancements.

The data also act as a starting point for determining which incursion situations warrant the use of enhanced engine performance for the hypothetical TCM aircraft. For example, if an incursion is detected when the aircraft has accelerated to 60 kts during its TO run, although the TO distance can be shortened by more than 250 ft by activating the control modes, the aircraft must still travel at least an additional 2,200 ft before clearing the 50-ft threshold. Instead, it may be possible to stop the aircraft within that distance by applying full brakes and thrust reversers. On the other hand, the stopping distance may be unacceptably long if an incursion occurs at higher speeds. In such cases, any improvement provided by the control modes may be desirable in order to prevent a collision. Availability of enhanced engine performance modes represents an additional degree of freedom that can be integrated into the safety guidelines for such emergency situations. Since the control modes are designed based on risk of engine failure, they can be more readily incorporated into this guideline development.

4.3 Propulsion-Only Flight

Although the runway incursion scenario involved activating both emergency control modes, the extra thrust provided by the OT mode is primarily responsible for shortening TO distance. To highlight the faster response mode, this subsection examines the benefits of using the control modes with a propulsion-controlled aircraft (PCA). For these simulation cases, the TCM aircraft was flown straight and level at 5,000 ft and 200 kts when all flight control surfaces (elevator, aileron, rudder, spoilers, and flaps) were failed (i.e., frozen in the position at time of failure). The two engines represented the only controllable “actuators” that can affect the flight trajectory.

A feedback control system (Figure 13) was developed to facilitate flying the aircraft with engines only. This control system—a hypothetical emergency system that is not currently implemented in any civil transport in service—is based on, but highly simplified from, the extensively researched and tested PCA control system developed by NASA (Ref. 26). The control system attempts to maintain desired values of flight path angle (γ) and roll angle (ϕ) through throttle modulation. The flight path angle controller consists of a proportional-integral feedback control structure that calculates throttle commands for both engines. The roll controller, also proportional-integral, calculates a differential value that is added to the left and subtracted from the right engine throttle setting. The gains for both controllers are fixed (i.e., no scheduling) and not optimal in any mathematically rigorous sense. Nevertheless, this implementation was sufficient for demonstrating the benefits of enhanced engine performance.

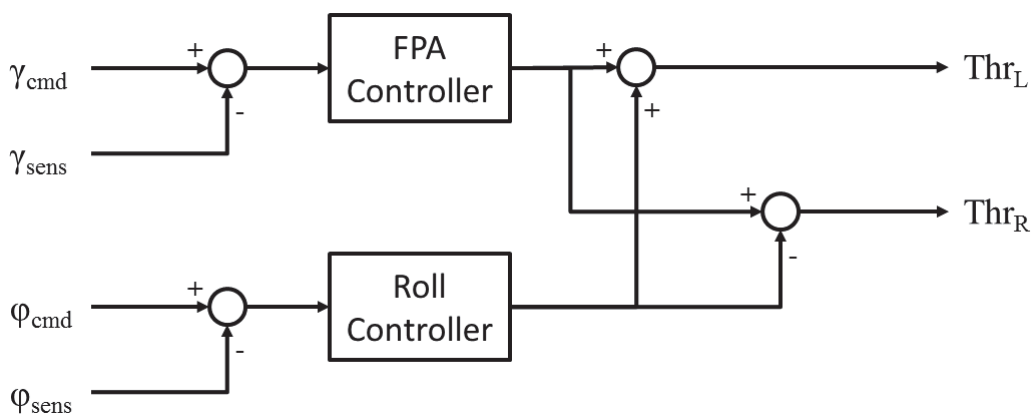

Figure 13.—Propulsion-only flight control system calculates collective and differential throttle settings to maintain flight path angle (FPA) and roll.

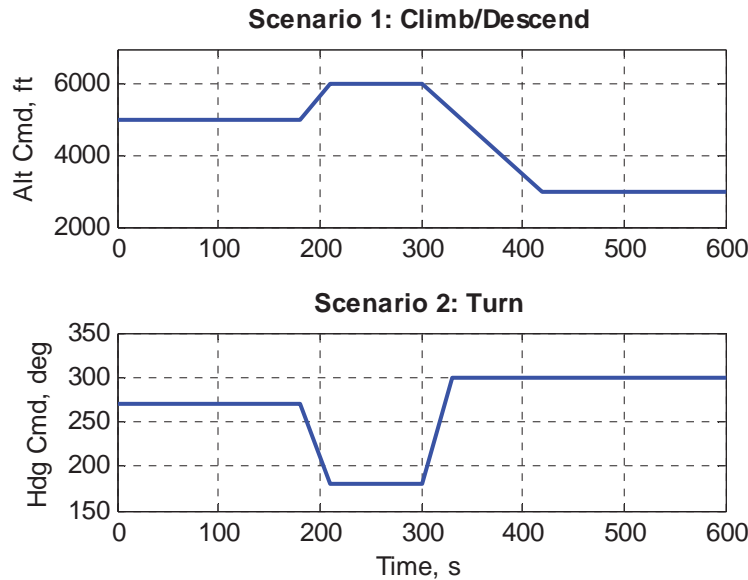

Figure 14.—Command profiles for altitude (Alt) and heading (Hdg) variation during propulsion-only flight. Each profile is executed separately, with the other command constant (e.g., altitude command profile with heading constant at 270°).

Two scenarios, both involving flight path maneuvers using only the engines, were simulated for the non-piloted evaluation. The command profiles are shown in Figure 14. In the first scenario, the aircraft had to climb from 5,000 to 6,000 ft before eventually descending to 3,000 ft while maintaining a fixed heading. In the second, the aircraft, while maintaining an altitude of 5,000 ft, had to turn left from a heading of 270° to 180°, and then turn right to 300°. Each of the two examples was simulated with the following three configurations:

- Nominal aircraft (i.e., no control surface failure, no PCA).
- Control surfaces failed at 60-sec mark; PCA using baseline engines.
- Control surfaces failed at 60-sec mark; PCA with enhanced performance modes active.

As previously mentioned, the TCM contains a simple, autopilot-like flight control system. This system was used to fly all test cases. For the nominal cases, the command profiles shown in Figure 14 were directly entered into the flight control system as inputs. Additionally, the auto-throttle was set to maintain 200 kts air speed. For the control surface failure cases, the altitude and heading portions of the TCM flight control system, which calculate flight path angle and roll commands, respectively, were redirected to the propulsion-only control system shown in Figure 13. It is important to note that without elevator authority, it is not possible to control altitude and air speed independently. Thus, air speed deviations were expected for the propulsion-only cases.

Engine health was also varied for each of the two scenarios described above. However, maneuvering the aircraft via throttle modulation emphasizes the responsiveness rather than magnitude of the engine thrust output. For these scenarios, the results for EOL and new engines were found to be quite similar qualitatively and quantitatively. Therefore, this paper presents the results for new engines only.

The guidelines used for the piloted evaluation of the propulsion-only scenario were similar to the framework described above with the exception of some modifications to facilitate testing. First, the nominal aircraft case was omitted. Piloted evaluation was only conducted on the cases with failed surfaces. Second, when the flight control surfaces failed, the pitch and roll trim controls in the cockpit

were remapped to the flight path angle and roll commands, respectively, for the PCA control system. The pilot controlled the crippled aircraft with these two trim controls. Third, the surfaces were failed immediately upon start of the simulation, fixed to their neutral positions. The pilot was then instructed to allow the PCA system to trim the aircraft to straight and level flight before commencing with the maneuverability tests. Fourth, the pilot was not instructed to follow a fixed flight trajectory for either of the two maneuvers. The goal was simply to achieve each altitude or heading waypoint in a controlled manner before progressing to the next. In other words, there was no time requirement to transition from one altitude/heading to another. Therefore, the piloted tests can only be evaluated in terms of whether the maneuver was safely performed, not how well the baseline and enhanced performance flight trajectories match. Finally, the tests were repeated several times, but the pilot was not informed whether or not enhanced engine performance was active during each run; he was simply instructed to fly each maneuver as well as he could.

4.3.1 Climb/Descend Maneuver

The non-piloted simulation results of the altitude maneuver case are shown in Figure 15. As expected, with the flight control surfaces failed, the aircraft is unable to maintain air speed, which decreases as the vehicle climbs and increases as it descends. Nonetheless, usage of the enhanced performance modes in conjunction with the propulsion-only control system (“PCA, Enhanced”) results in an altitude trajectory that is nearly identical to that of the nominal aircraft. On the other hand, the propulsion-only aircraft with baseline engines (“PCA, Baseline”) could only successfully perform the ascent portion of the commanded profile. On the descent portion, the aircraft was unable to return to level flight and entered into unstable oscillations of altitude and air speed.

More detailed investigation determined that a combination of the flight control system and the slow dynamic thrust response of the engines at low power settings resulted in an instability akin to pilot-induced oscillations (PIO). Figure 16 shows the throttle command and thrust response for both propulsion-only cases (thrust is normalized as a percentage of 40,000 lb so that a time response comparison with throttle can be made). Without elevator control, low engine power was required to maintain the negative flight path angle during the descent (between 300 and 400 sec).

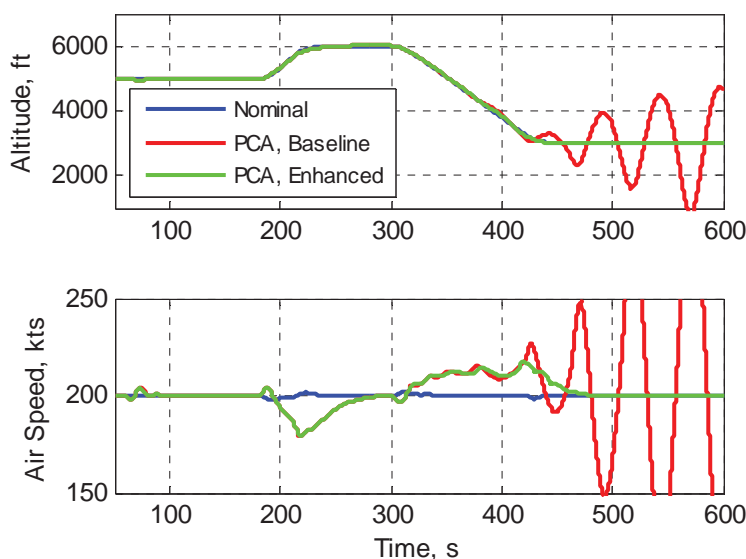

Figure 15.—Climb/descend maneuver: comparing nominal aircraft against propulsion-only flight control without and with engine performance enhancing control modes.

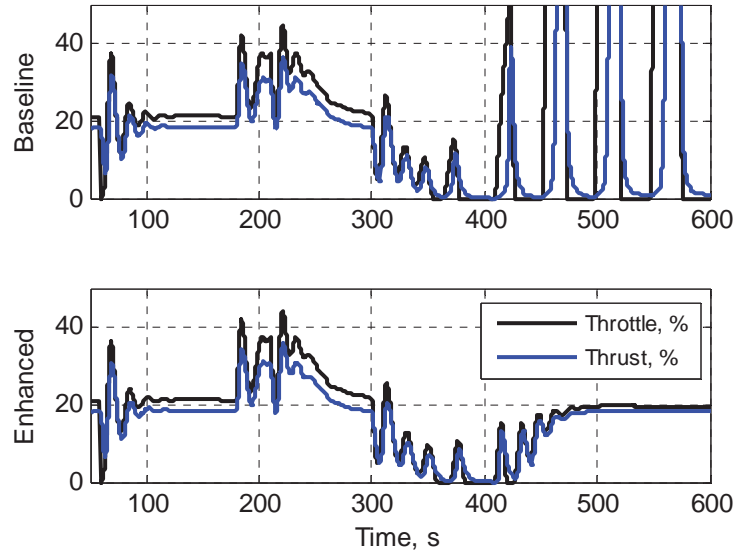

Figure 16.—Climb/descend maneuver: throttle command and thrust response (normalized to 40,000 lb) for propulsion-only cases.

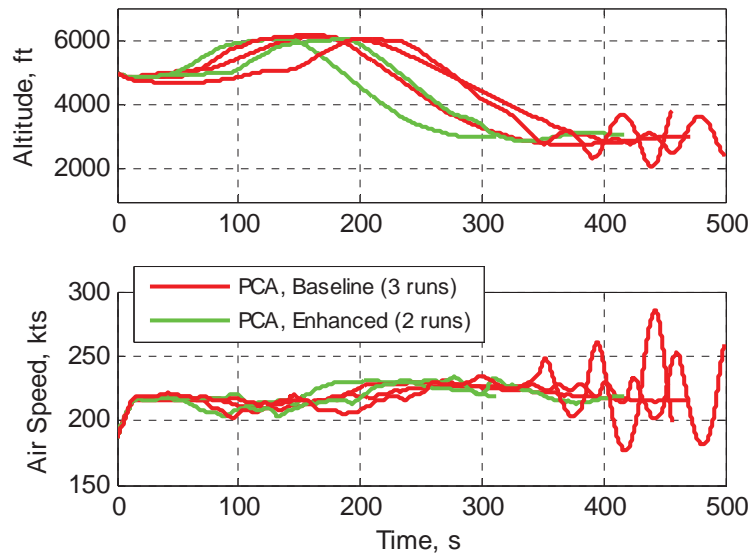

Figure 17.—Climb/descend maneuver: piloted evaluations.

Returning to level flight required a sharp increase in power just after the 400-sec mark. Unfortunately, the altitude controller was designed to expect changes in flight path angle that are faster than what the baseline engines could provide, resulting in overly aggressive corrective commands. Both the slow thrust response and the aggressive throttle commands are evident for the baseline case shown in Figure 16. Instability does not occur during the ascent portion because the transition from climb to level flight requires decreasing power, which the engines can adequately respond to with or without enhanced performance.

Figure 17 shows the results of the piloted simulation of the climb/descend maneuver. The test was conducted a total of five times, twice with enhanced engine performance active. The altitude trajectories are relatively similar to those obtained using the autopilot control system (Figure 15). There are, however, small differences in air speed from the non-piloted case; recall that for the piloted simulations, the control surfaces were fixed to their neutral positions, whereas for the autopilot case, the aircraft was trimmed to

200 kts before failure occurred. For two of the three baseline engine cases, the pilot was unable to prevent the aforementioned altitude/speed oscillations. For the unstable cases, the pilot was aware of the control surface inoperability and therefore did not command erroneous, overcompensating inputs like the autopilot. Hence, the instability was at least partially caused by an incompatibility between the slow response time of the baseline engines and the simplistic design of the PCA control system. Nevertheless, the oscillations did not occur when using the enhanced performance modes, whether the aircraft was autonomously or pilot controlled. Thus, enhanced engine performance provides a noticeable buffer against such instabilities, regardless of the nature of their cause. This type of protection could be crucial during a situation where the flight crew would have limited time to acclimate to the unfamiliar handling qualities of the damaged aircraft.

4.3.2 Turning Maneuver

Figure 18 summarizes the aircraft parameters of interest for the turning maneuver simulation runs. With the enhanced performance modes active, the aircraft with total control surface failure was able to reproduce the heading trajectory of a nominal aircraft. However, the rolling maneuvers required to enter and exit the turns are not ideal. The difficulty lies in maintaining a constant altitude while changing the roll angle of the aircraft. With the control surfaces frozen, rolling the aircraft was accomplished through

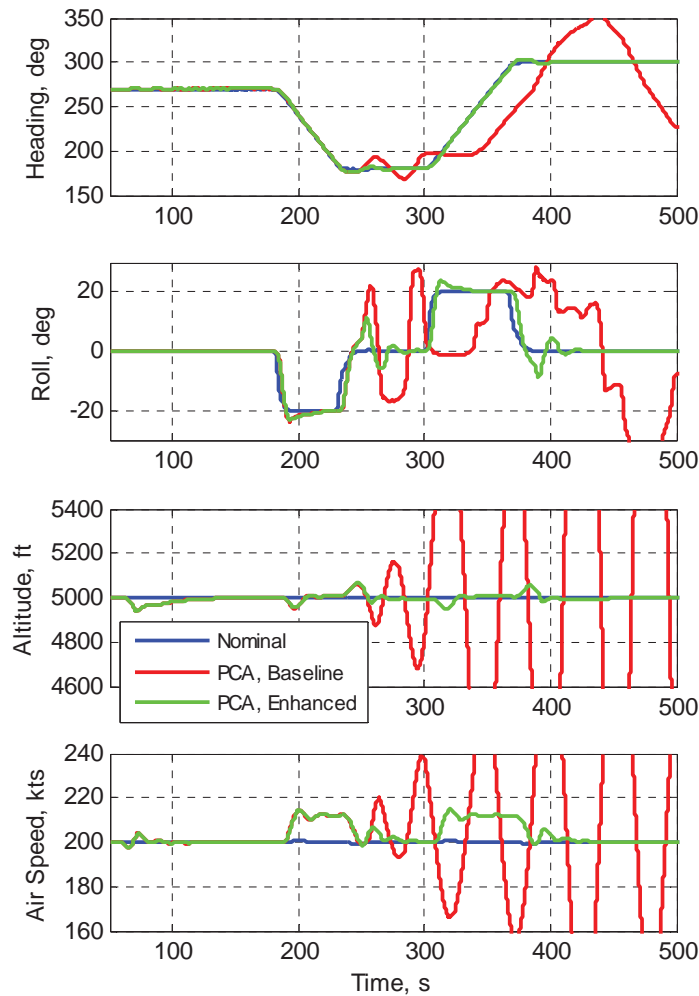

Figure 18.—Turning maneuver: comparing nominal aircraft against propulsion-only flight control without and with engine performance enhancing control modes.

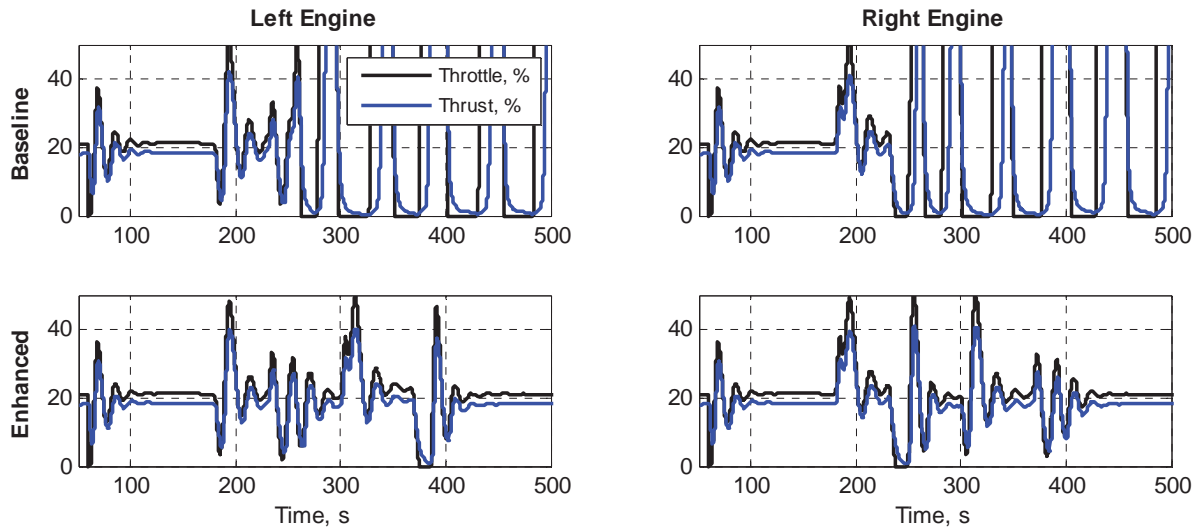

Figure 19.—Turning maneuver: throttle command and thrust response (normalized to 40,000 lb) for propulsion-only cases.

differential thrust. However, changes to the roll angle rotate the lift vector (e.g., increasing roll decreases the vertical component of the lift vector, causing the aircraft to descend). Therefore, in order to maintain altitude, changes in the total thrust were required, which interfered with the differential thrust commands. For these turning simulations, since the total and differential thrust portions of the propulsion-only flight control system were not coupled, some altitude change while rolling was unavoidable and the roll response of the aircraft had a tendency to overshoot. It is important to note that maintaining a steady non-zero roll angle does not require differential thrust; therefore, the control system was able to maintain a steady turn at constant altitude. The conflicting differential and total thrust commands occurred when roll angle was dynamic.

Without enhanced engine performance, however, the aircraft became unstable for reasons similar to those in the climb/descent case. Figure 19 shows the throttle commands and thrust responses for the baseline and enhanced engines, differentiating between the left and right engines. Again, overcompensation in the commands due to the relatively slow response of the baseline engines is evident. In this case, the instability begins approximately 250 sec into the run. Just prior to this point, differential thrust was applied to return the aircraft to level flight and exit out of the first turn. Total thrust was decreased to correct the corresponding increase in altitude. However, similar to the descent example, engine thrust could not be increased quickly enough to return the aircraft to a stable altitude.

Figure 20 presents the results of the piloted evaluation for this scenario. The pilot performed the maneuver six times, half of which utilized enhanced performance control modes. In this case, instability did not occur for any of the runs. Moreover, unlike the autopilot case, the control modes do not appear to offer any benefits since all six flight trajectories are relatively similar. This apparent discrepancy is due to the more conservative flying style of the human pilot—a result of knowing the impaired nature of the aircraft—as compared to the automated counterpart. Comparing the roll time histories in Figure 18 and Figure 20, the pilot rolled into and out of each turn more slowly than the autopilot. Moreover, the pilot prioritized turning over maintaining altitude. The autopilot with PCA controls treated both the heading maneuver and altitude hold commands equally. Therefore, although the autopilot exerted significantly tighter control over altitude for the duration of the maneuver with the control modes active, it could not maintain stable flight using the baseline engines. On the other hand, the piloted maneuvers were within the capabilities of the baseline engines and did not require the extra protection provided by the enhanced performance modes.

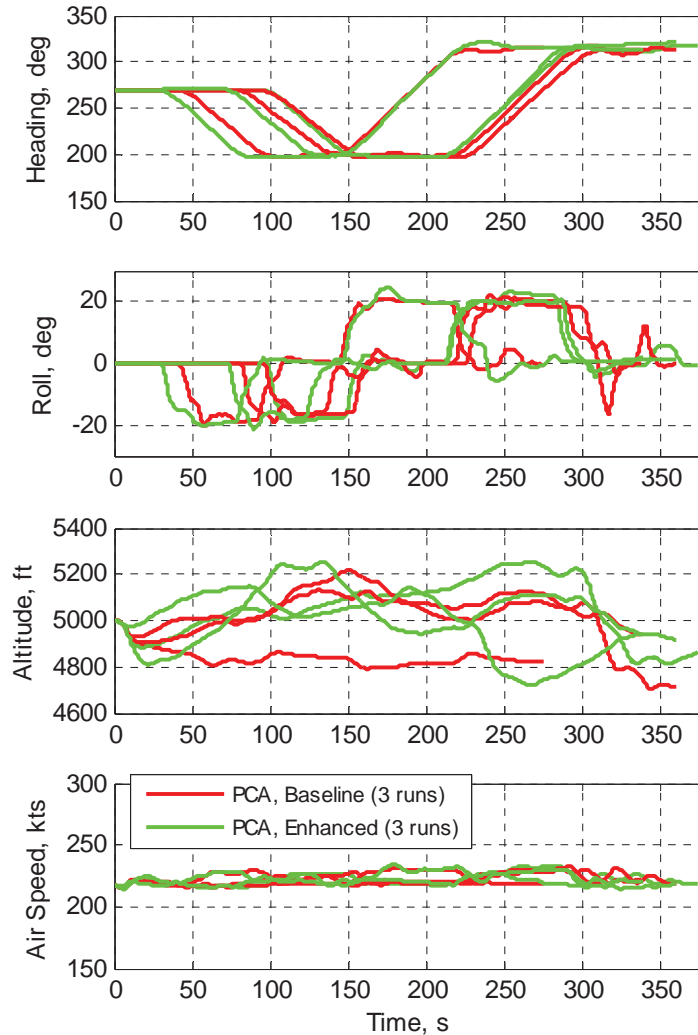

Figure 20.—Turning maneuver: piloted evaluations.

5.0 Summary and Conclusions

This paper evaluates the effects and benefits of previously developed engine performance enhancing control modes on aircraft operation, particularly during emergency scenarios. The control modes, faster response and overthrust, provide improved thrust capability in terms of dynamic responsiveness and maximum output, respectively. Increased performance is dependent upon the allowed elevation of engine failure risk. A notional implementation of the control modes is presented using a combined engine/aircraft simulation. Computer simulations and piloted evaluations were conducted to identify the potential benefits the control modes provide to an aircraft during an emergency. The following summarizes the conclusions that can be drawn from the results presented in this paper:

- The control modes were implemented such that activation does not significantly affect the aircraft flight dynamics. Therefore, minimal pilot effort is required to maintain the flight trajectory prior to mode activation.
- For runway incursions, the benefits of enhanced engine performance—overthrust in particular—diminish with later detection of the incursion event. Enhanced engine performance represents an additional consideration in the trade-off study that must be conducted to determine the guidelines for runway incursions.

- For the emergency scenario of propulsion-only flight where the aircraft experiences a total loss of control surface authority, the enhanced performance modes provide some protection against instabilities similar to pilot-induced oscillations. Computer simulation of various flight maneuvers showed that using the control modes prevented these instabilities where the baseline engines were unsuccessful. However, piloted evaluations showed that the baseline engines could suffice in some instances if the inputs were more conservative and maneuverability requirements more lax.

References

1. Guo, T. and Litt, J.S., “Resilient Propulsion Control Research for the NASA Integrated Resilient Aircraft Control (IRAC) Project,” AIAA-2007-2802, AIAA Infotech@Aerospace Conference, Rohnert Park, California, 7-10 May 2007.
2. Richter, H. and Litt, J.S., “A Novel Controller for Gas Turbine Engines with Aggressive Limit Management,” AIAA-2011-5857, 47th AIAA/ASME/SAE/ASEE Joint Propulsion Conference and Exhibit, San Diego, California, 31 July-3 August 2011.
3. Sharifi, R., Hacker, J., and Cao, C., “Adaptive Engine Control with Multiple Constraints,” AIAA-2011-1592, AIAA Infotech@Aerospace Conference, St. Louis, Missouri, 29-31 March 2011.
4. Csank, J.T., May, R.D., Guo, T., and Litt, J.S., “The Effect of Modified Control Limits on the Performance of a Generic Commercial Aircraft Engine,” AIAA-2011-5972, 47th AIAA/ASME/SAE/ASEE Joint Propulsion Conference and Exhibit, San Diego, California, 31 July-3 August 2011.
5. May, R.D., Csank, J.T., Guo, T., and Litt, J.S., “Improving Engine Responsiveness during Approach through High Speed Idle Control,” AIAA-2011-5973, 47th AIAA/ASME/SAE/ASEE Joint Propulsion Conference and Exhibit, San Diego, California, 31 July-3 August 2011.
6. Nguyen, N. and Stepanyan, V., “Flight-Propulsion Response Requirements for Directional Stability and Control,” AIAA-2010-3471, AIAA Infotech@Aerospace Conference, Atlanta, Georgia, 20-22 April 2010.
7. Urnes, J.M., Sr. and Nielsen, Z.A., “Use of Propulsion Commands to Control Directional Stability of a Damaged Transport Aircraft,” AIAA-2010-3470, AIAA Infotech@Aerospace Conference, Atlanta, Georgia, 20-22 April 2010.
8. May, R.D., Lemon, K.A., Csank, J.T., Litt, J.S., and Guo, T., “The Effect of Faster Engine Response on the Lateral Directional Control of a Damaged Aircraft,” AIAA-2011-6307, AIAA Guidance, Navigation and Control Conference, Portland, Oregon, 8-11 August 2011.
9. Litt, J.S., Guo, T., Sower, T.S., Chicatelli, A.K., Fulton, C.E., May, R.D., and Owen, A.K., “Pilot-in-the-Loop Evaluation of a Yaw Rate to Throttle Feedback Control with Enhanced Engine Response,” AIAA-2012-5027, AIAA Guidance, Navigation, and Control Conference, Minneapolis, Minnesota, 13-16 August 2012.
10. Litt, J.S., Sowers, T.S., Owen, A.K., Fulton, C.E., and Chicatelli, A.K., “Flight Simulator Evaluation of Enhanced Propulsion Control Modes for Emergency Operation,” AIAA-2012-2604, AIAA Infotech@Aerospace Conference, Garden Grove, California, 19-21 June 2012.
11. Litt, J.S., Sharp, L.M., and Guo, T., “A Risk Assessment Architecture for Enhanced Engine Operation,” AIAA-2010-3469, AIAA Infotech@Aerospace Conference, Atlanta, Georgia, 20-22 April 2010.
12. Csank, J.T., May, R.D., Litt, J.S., and Guo, T., “A Sensitivity Study of Commercial Aircraft Engine Response for Emergency Situations,” NASA Technical Memorandum, NASA/TM—2011-217004.
13. Liu, Y., Litt, J.S., and Guo, T., “Design and Demonstration of Emergency Control Modes for Enhanced Engine Performance,” AIAA-2013-3625, 49th AIAA/ASME/SAE/ASEE Joint Propulsion Conference, San Jose, California, 14-17 July 2013.
14. May, R.D., Csank, J., Lavelle, T.M., Litt, J.S., and Guo, T., “A High-Fidelity Simulation of a Generic Commercial Aircraft Engine and Controller,” AIAA-2010-6630, 46th AIAA/ASME/SAE/ASEE Joint Propulsion Conference and Exhibit, Nashville, Tennessee, 25-28 July 2010.

15. Heuschen, R.M., "Development of the Transport Class Model (TCM) Aircraft Simulation From a Sub-Scale Generic Transport Model (GTM) Simulation," NASA Technical Memorandum, NASA/TM—2011-217169, August 2011.
16. National Transportation Safety Board, "NW Airlines, Inc., Flights 1482 and 299 Runway Incursion and Collision Detroit Metropolitan/Wayne County Airport Romulus, Michigan, December 3, 1990," NTSB/AAR-91-05.
17. National Transportation Safety Board, "Aircraft Accident Report: American Airlines, Inc. McDonnell Douglas DC-10-10, N103AA. Near Windsor, Ontario, Canada, June 12, 1972," PB-219 370, 1973.
18. National Transportation Safety Board, "Aircraft Accident Report, United Airlines Flight 232, McDonnell Douglas DC-1040, Sioux Gateway Airport, Sioux City, Iowa, July 19, 1989," PBSO-910406, NTSB/AARSO/06, 1990.
19. Lemaignan, B., "Flying With No Flight Controls: Handling Qualities Analyses of the Baghdad Event," AIAA-2005-5907, AIAA Atmospheric Flight Mechanics Conference and Exhibit, San Francisco, California, 15-18 August 2005.
20. Burcham, F.W., Jr. and Fullerton, C.G., "Controlling Crippled Aircraft—With Throttles," NASA Technical Memorandum, NASA TM-104238, 1991.
21. Burcham, F.W., Jr., Fullerton, C.G., and Maine, T.A., "Manual Manipulation of Engine Throttles for Emergency Flight Control," NASA Technical Memorandum, NASA/TM—2004-212045, January 2004.
22. Aeronautics and Space, 14 C.F.R. pt. 33.75 (2012).
23. "Inlet Total-Pressure-Distortion Considerations for Gas-Turbine Engines," SAE AIR1419 Rev. A, 1999.
24. Csank, J., May, R.D., Litt, J.S., and Guo, T., "Control Design for a Generic Commercial Aircraft Engine," AIAA-2010-6629, 46th AIAA/ASME/SAE/ASEE Joint Propulsion Conference and Exhibit, Nashville, Tennessee, 25-28 July 2010.
25. X-Plane, Software Package, Ver. 9, Laminar Research, Columbia, South Carolina, 2011.
26. Burcham, F.W., Jr., Maine, T.A., Fullerton, C.G., and Webb, L.D., "Development and Flight Evaluation of an Emergency Digital Flight Control System Using Only Engine Thrust on an F-15 Airplane," NASA Technical Paper, NASA TP-3627, September 1996.

