



# **Thermal Runaway Severity Reduction Assessment For EVA Li-ion Batteries**

**By  
Eric Darcy/NASA-JSC**

**For  
2014 JSC Connect Event  
Energy Storage & Management**

**24 Sept 2014**

# Team and Contents

- NASA Engineering Safety Center Lead Effort
  - Paul Shack, Assessment Lead
  - Chris Iannello, NESC Technical Fellow for Electrical Power
  - Steve Rickman, NESC Technical Fellow for Passive Thermal
  - Eric Darcy, Test Lead for EVA Batteries, NASA-JSC
  - Sam Russell, Mike Fowler, Judy Jeevarajan, Craig Clark, John Weintritt, Christina Deoja and Stacie Cox/NASA-JSC
  - Rob Button, Tom Miller, Penni Dalton/NASA-GRC
  - Dan Doughty, Bruce Drolen, Ralph White, Gary Bayles, and Jim Womack/NESC Consultants
- Agenda
  - Background on the EVA batteries
  - Motivation and objectives
  - Trigger method selected and why
  - Assessments of current designs
  - Verification of subscale mitigation measures
  - Full scale LREBA with those measures leads to failure
  - Consequence of cell TR ejecta products to TR propagation
  - Full scale LREBA with adjacent cells protected from cell vent path
  - Bank test to verify benefits of cell fusing
  - Lessons learned to date

# Background - Li-ion Rechargeable EVA Battery Assembly (LREBA)

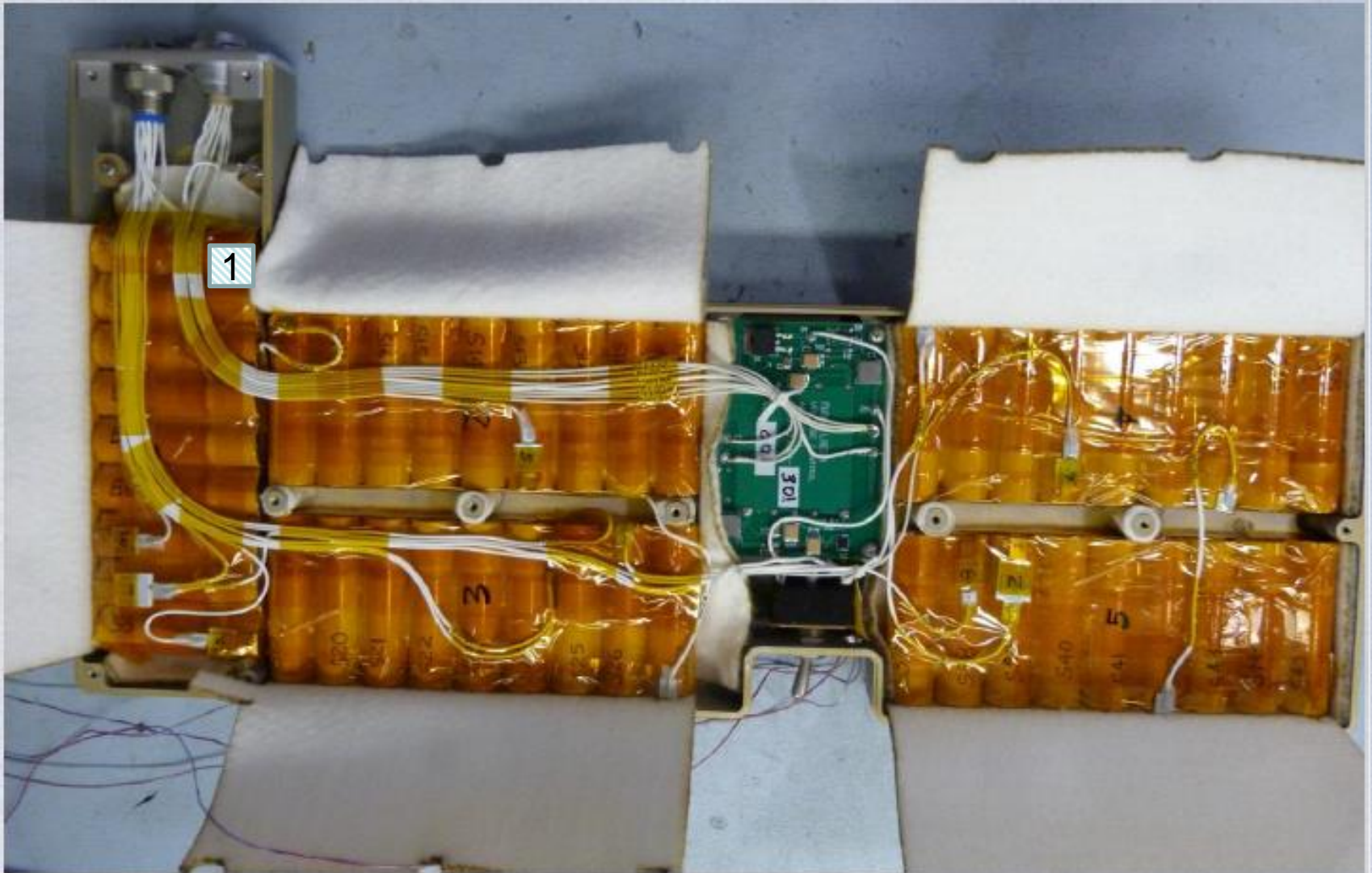

9P-5S Array of Samsung 2.6Ah 18650 cells to power the spacesuit helmet lights and camera and glove heaters

# Background – Li-ion Pistol Grip Tool Battery

- 10-cell Li-ion 18650 battery
  - 10S for discharge
  - 2P-5S for charge
- Battery is enclosed in tool holster except for end with the D-latch

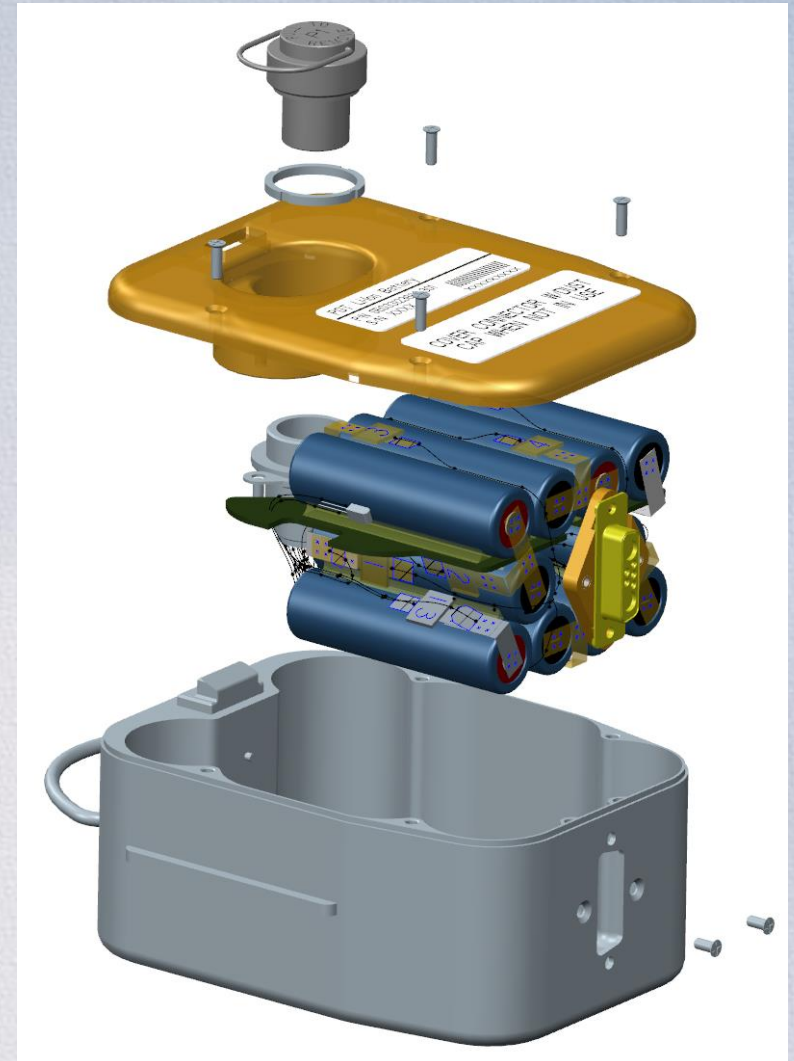

# Background – EMU Long Life Battery (LLB)



## Design Features

- 80 Li-ion cells (16p-5s)
- ICR-18650J from E-one Moli Energy

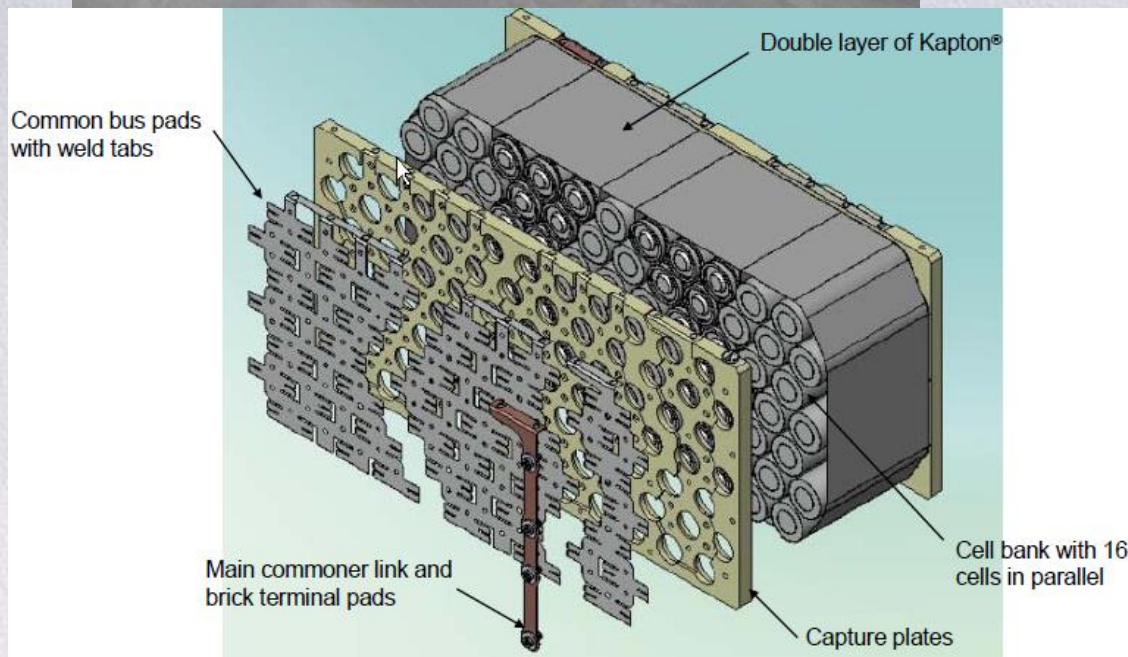

# Background and Motivation

- NASA is no longer only relying on prevention measures for reducing single cell internal short hazard
  - Cell screening known to not be fool proof against latent defects that can lead to field failures
  - Reasonable design and operational measures have been shown to reduce severity
- Revised battery safety standard (JSC 20793 RevC) requires determining the hazard by test in all designs  $> 80\text{Wh}$  and assessing possible severity mitigation measures
- This assessment is a pathfinder for that approach and will be done on 3 EVA batteries

# Selected Bottom Patch Heaters For Triggering TR

- Two small (3/4"x3/4") patch heaters located on the bottom of cylindrical can
  - Nichrome wire glued to Mica paper
  - Adhered to bare can by cement bases adhesive
- Each has 6" of Nichrome wire for a total of 12" per pair
  - Pair can be powered by up to 90W
- Main benefit of design – more relevant cell internal short
  - Deliver high heat flux away from seals, PTC, and CID located in cell header
  - leaves an axial bond line undisturbed for gluing cell together in one plane
  - More likely to result in coincident cell venting and TR runaway

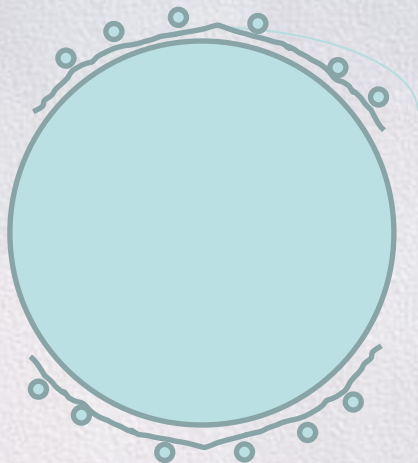

# Cell TR Response vs Heat Power

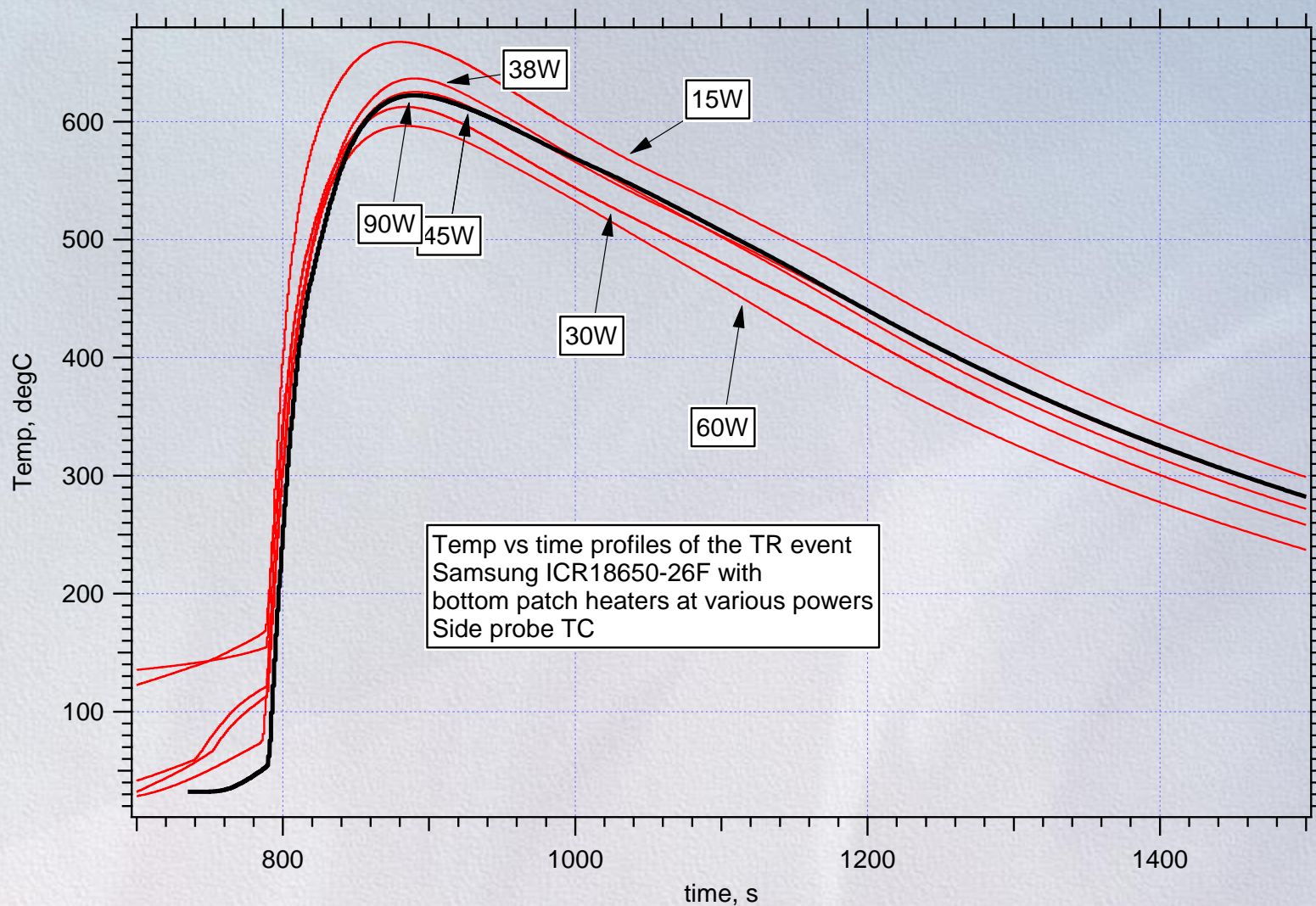

- TR output heat fairly independent of heater input power
- High power preferred to reduce risk of biasing hot adjacent cells



# LREBA 9P Bank Test – Baseline Design



- Picket fence 9P bank with cells in axial contact and with epoxy bond line between cells
  - End cell trigger with 45W
  - Open air environment
- Full cascade of cell TR propagation in about 10 minutes
- Similar result found with LPGT brick
- LREBA and LPGT baseline designs found susceptible to TR propagation



LPGT brick post TR Test

# First Round of Mitigation Measures

- Ensure cell-cell spacing 1-2mm with FR4/G10 capture plates
  - Reduce thermal conduction from cell to cell
- Integrate fusible links into Ni-201 bus plates on positive only
  - Isolate cell with internal shorts from parallel cells
  - 15A open current
  - Reduce thermal conduction via electrical connection
- Include radiation barrier between cells in 2mm spacing design
- Test under inert gas
  - Reduce chaos associated with burning cell ejecta
- Results
  - No TR propagation in all 4 tests conducted in inert gas
    - Radiation barriers helped slightly
    - But spacing between cells found most significant
      - Picket fence design propagated in inert gas
  - In open air, propagation was likely due to flammable ejecta impinging on adjacent cells

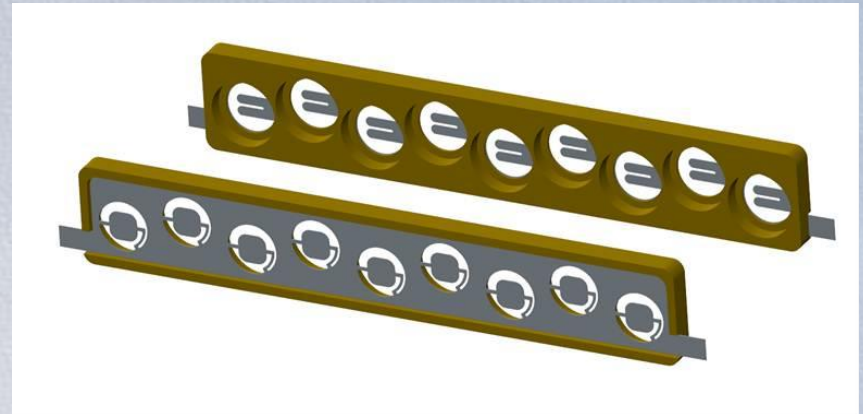

# Full Scale Battery Test – Total Propagation

- End cell in corner of dogleg was triggered.
- All 45 cells went into TR over 29 minutes.
- 231 seconds from trigger cell TR to adjacent cell TR
- Flames exited housing after 5<sup>th</sup> cell driven into TR 11 minutes into the test
- Vented ejecta bypassed fusible links and created short paths

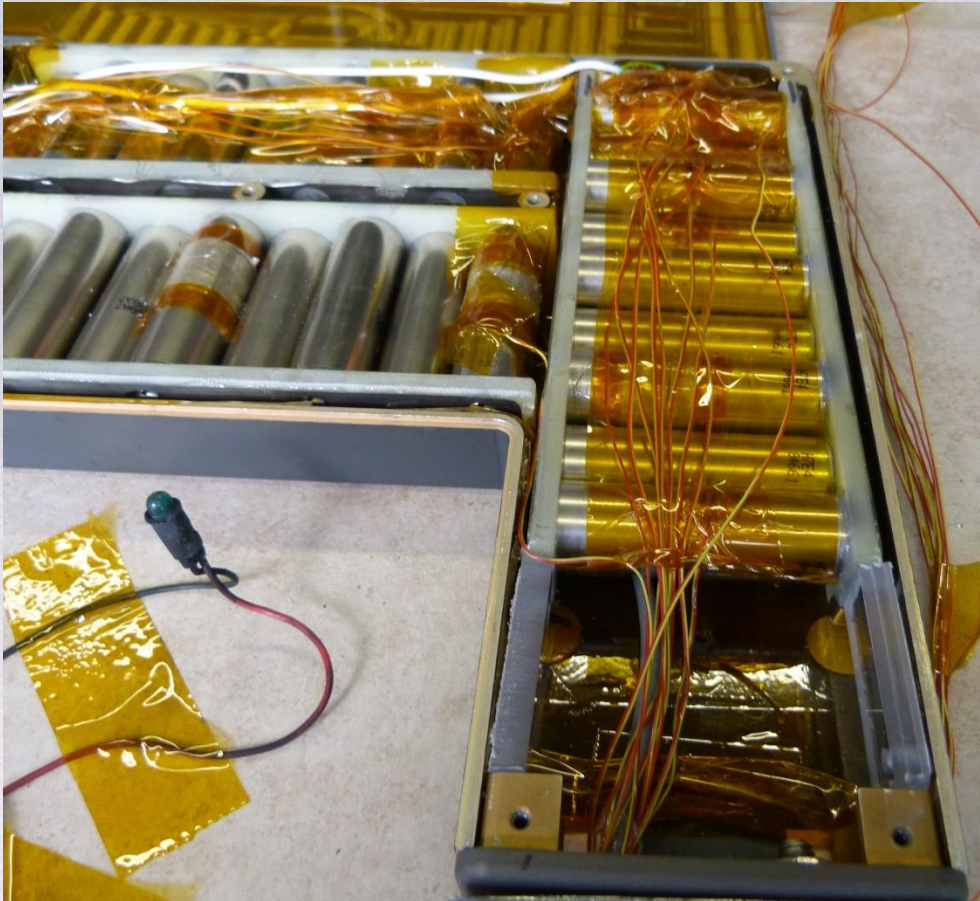

Bank 1 experienced a sustained short immediately after TR of trigger cell

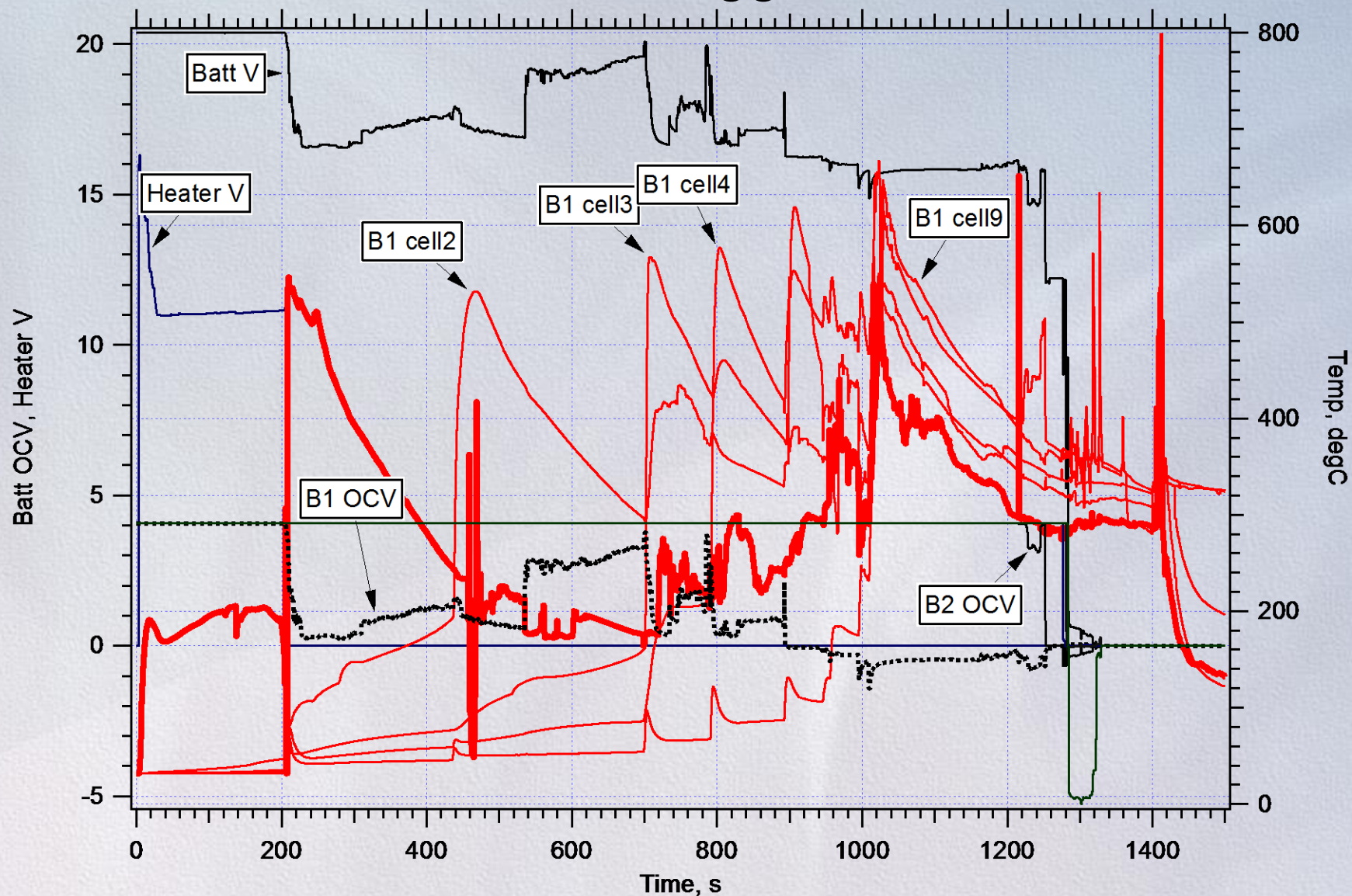

# Cell TR Ejecta Assessment

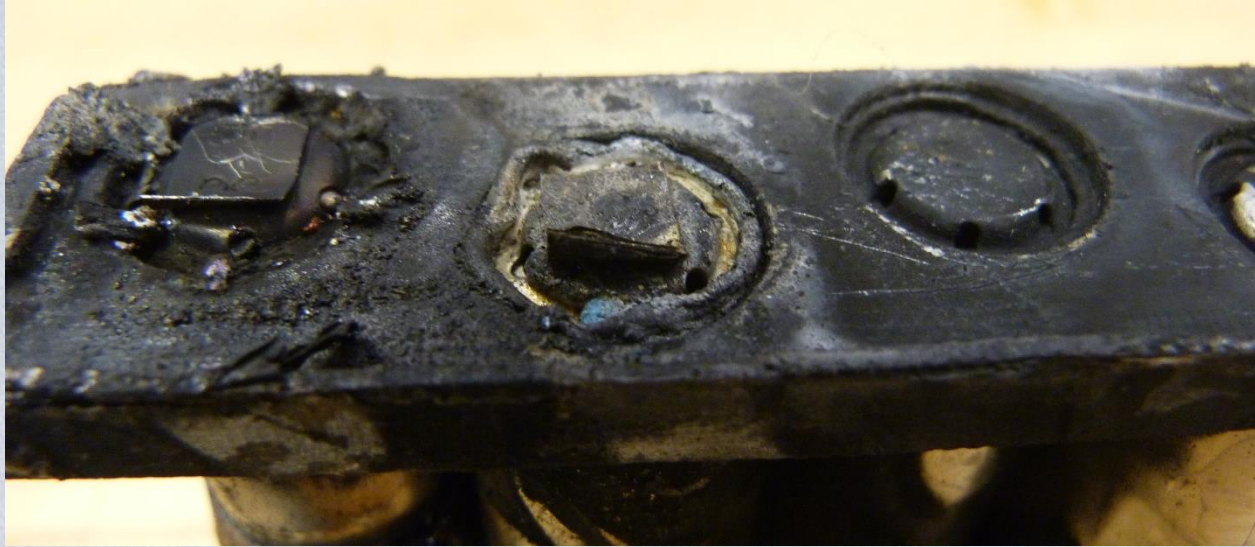

- Trigger cell next to 0% SoC cell without bus bars and with bank inside LREBA enclosure to assess if TR ejecta can electrically bridge between cells
- Cell 2 appears to have been thermally overstressed causing its sealing gasket to melt
  - This cell definitely vented, albeit without going into TR
  - Internal gas temperatures in inside LREBA enclosure exceeded 230C
  - All other cells, #3-9 have healthy OCVs
  - Cell TR ejecta found to be electrically conductive
- Either way, it indicates that design must
  - Manage the cell TR ejecta to prevent collateral damage
  - Reduce trip current of fusible links
  - Fusible links are more effective on negative terminal

# Next Full Scale LREBA Test Configuration

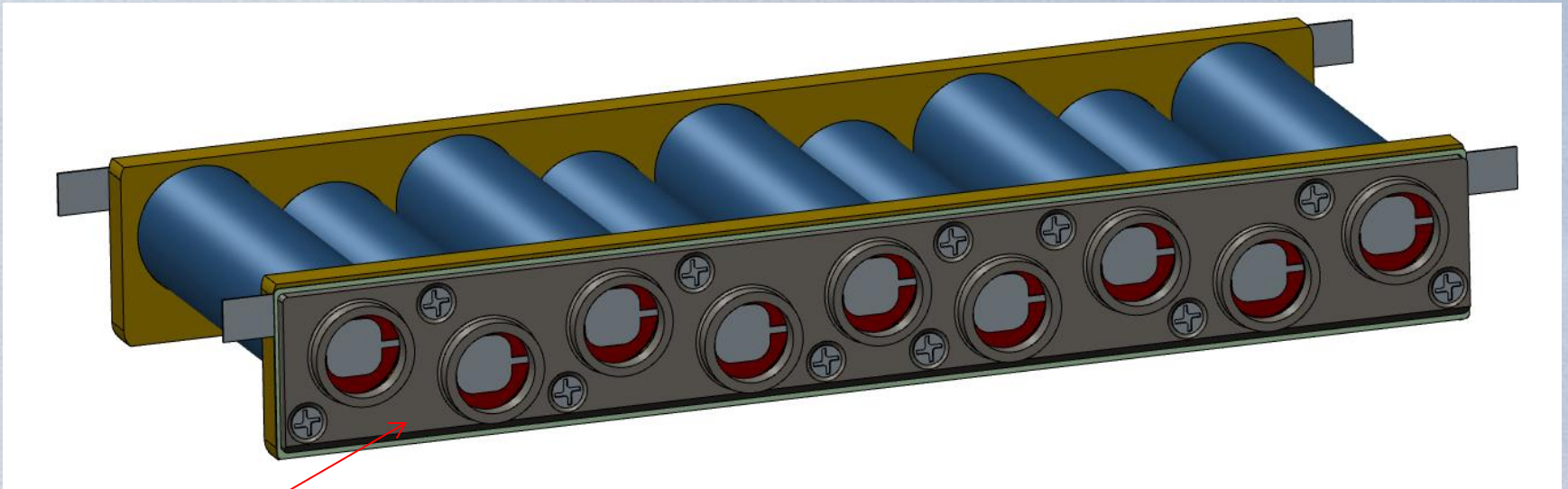

## Cell Ejecta Exhaust Piped Top

- Macor (machinable glass ceramic) with G10 gasket between Ni bus and manifold top
- Matching holes in housing for pipes
- Mica paper wrapped on cell cans
- Fusible bus bars on both positives and negatives
  - Same 15A trip

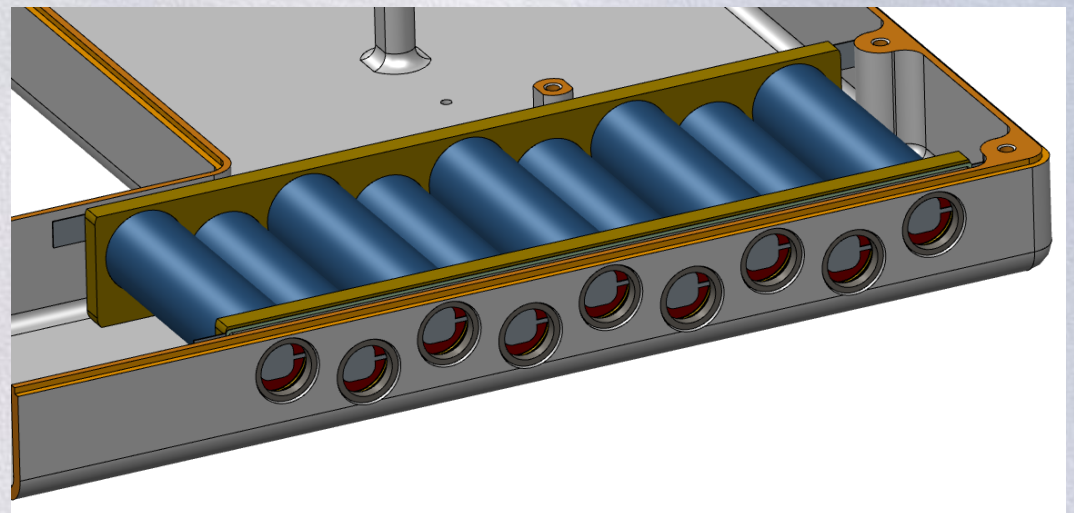

9P bank inside LREBA housing with exhaust holes

# Details of new mitigation features

- Gen 1 LREBA capture and Ni bus plates with same housing/lid
- Special care to avoid heater wire termination to damage cell case
  - Added mica paper between termination and cell case
- Exhaust pipe manifold material Macor (machinable glass ceramic)
  - Very carefully fastened it to the G10 capture plate
    - Place 3 layers of Kapton and 0.005" G10 gasket in between G10 capture plate and Macor manifold
    - Kapton layers are compliant and help seal the Macor/G10 gap
  - Al tape added top of pipes to seal pipes of non-trigger cells to fresh limit air circulation
- Added Mica paper insulation to the cell cans of non-trigger cells

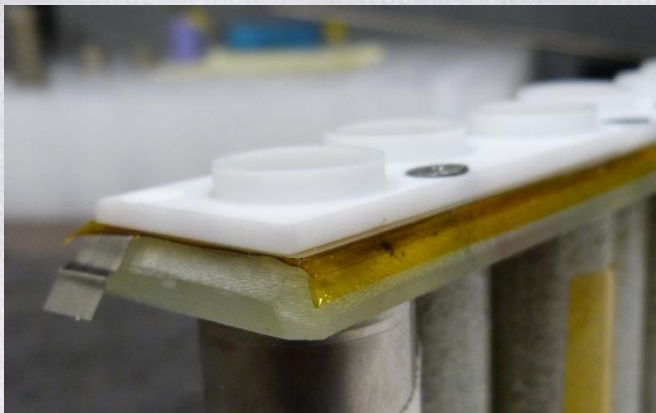

# More Photos of Mitigation Features

Machinable glass ceramic (Macor®)



Fusible (15A) bus plates connected on both terminals

Mica paper as radiation barriers and to electrically isolate cell cans 2-8  
Heater placed on end cells 1 & 9

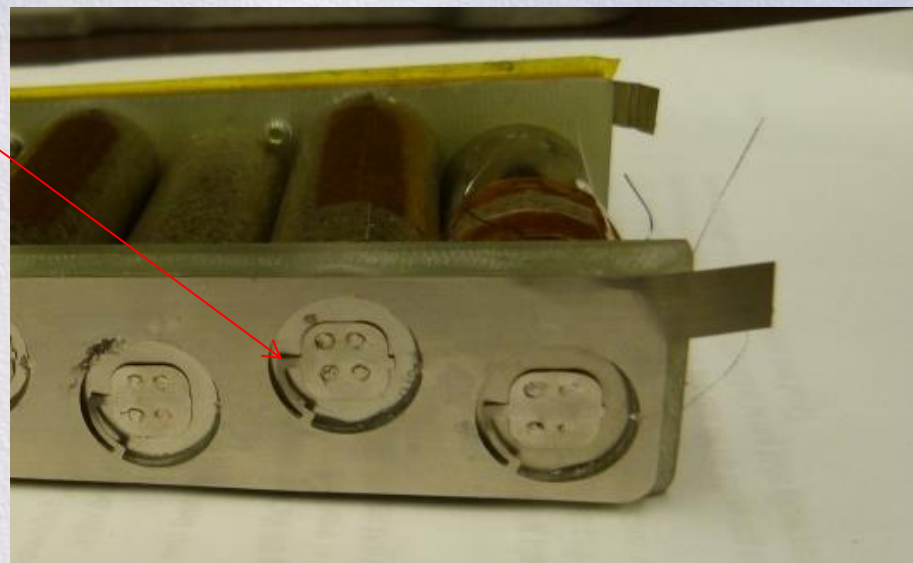



# Pre Test Photos

One active 9P bank in dogleg with end cell trigger heaters powered at 90W  
4 dummy banks uncharged to take up volume inside enclosure

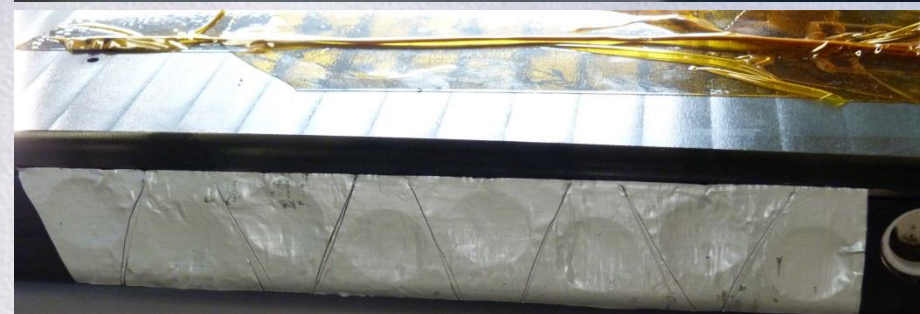

Al foil covering housing ejecta holes to limit air circulation and prevent FOD entering

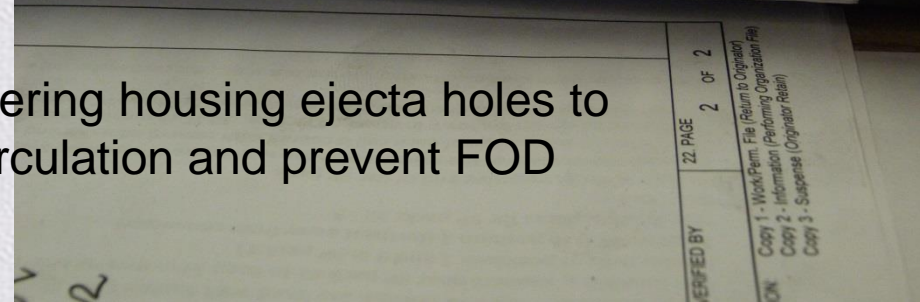

# No TR Propagation

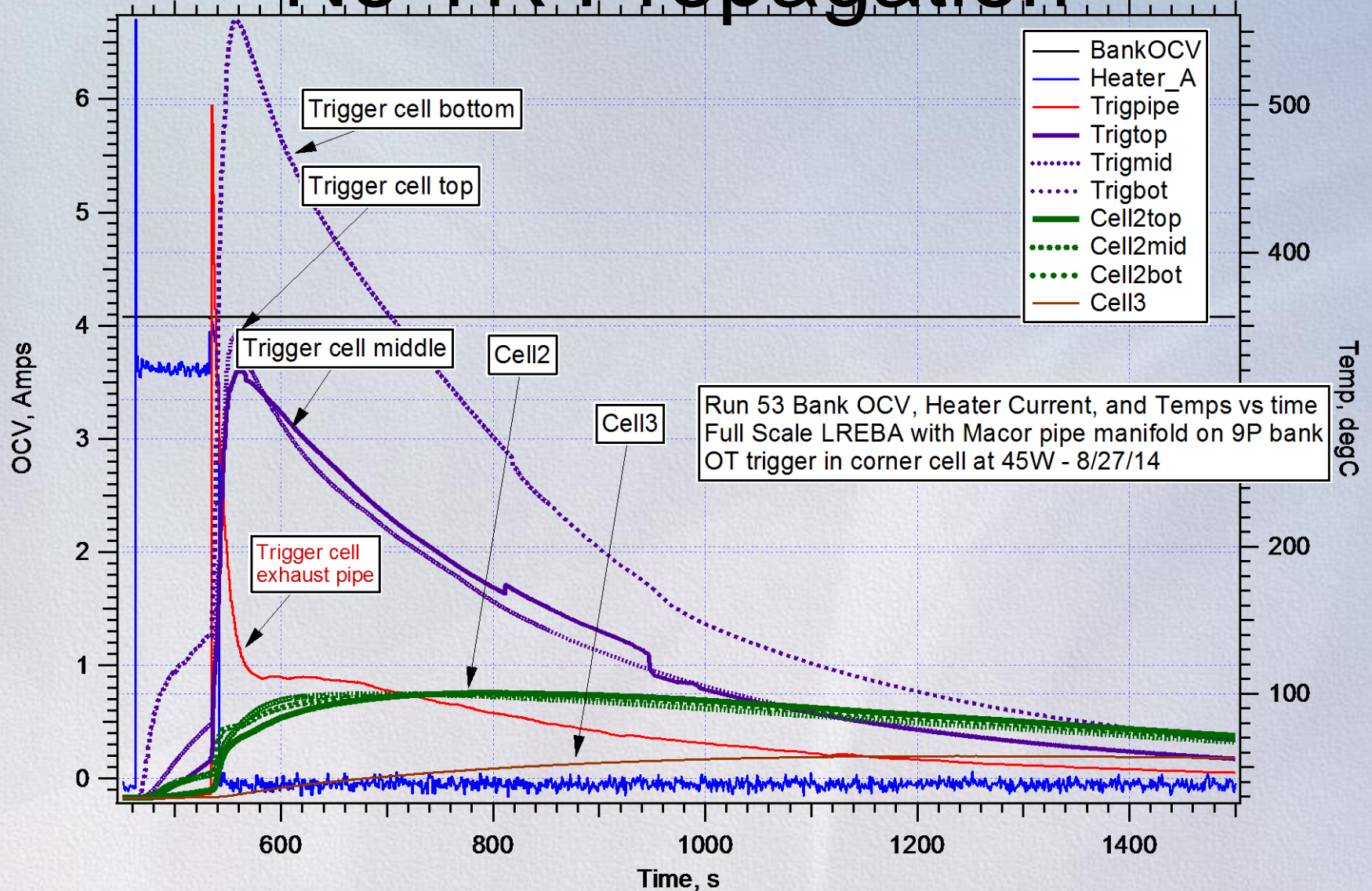

Half of heater fails open in first second, heater runs at 45W, nevertheless, TR reached in 72s. Bottom of trigger cell reaches 543°C, while mid and top get to 319-344°C. Cell 2 maxes out on all 3 TCs at 100°C.

# Close-up

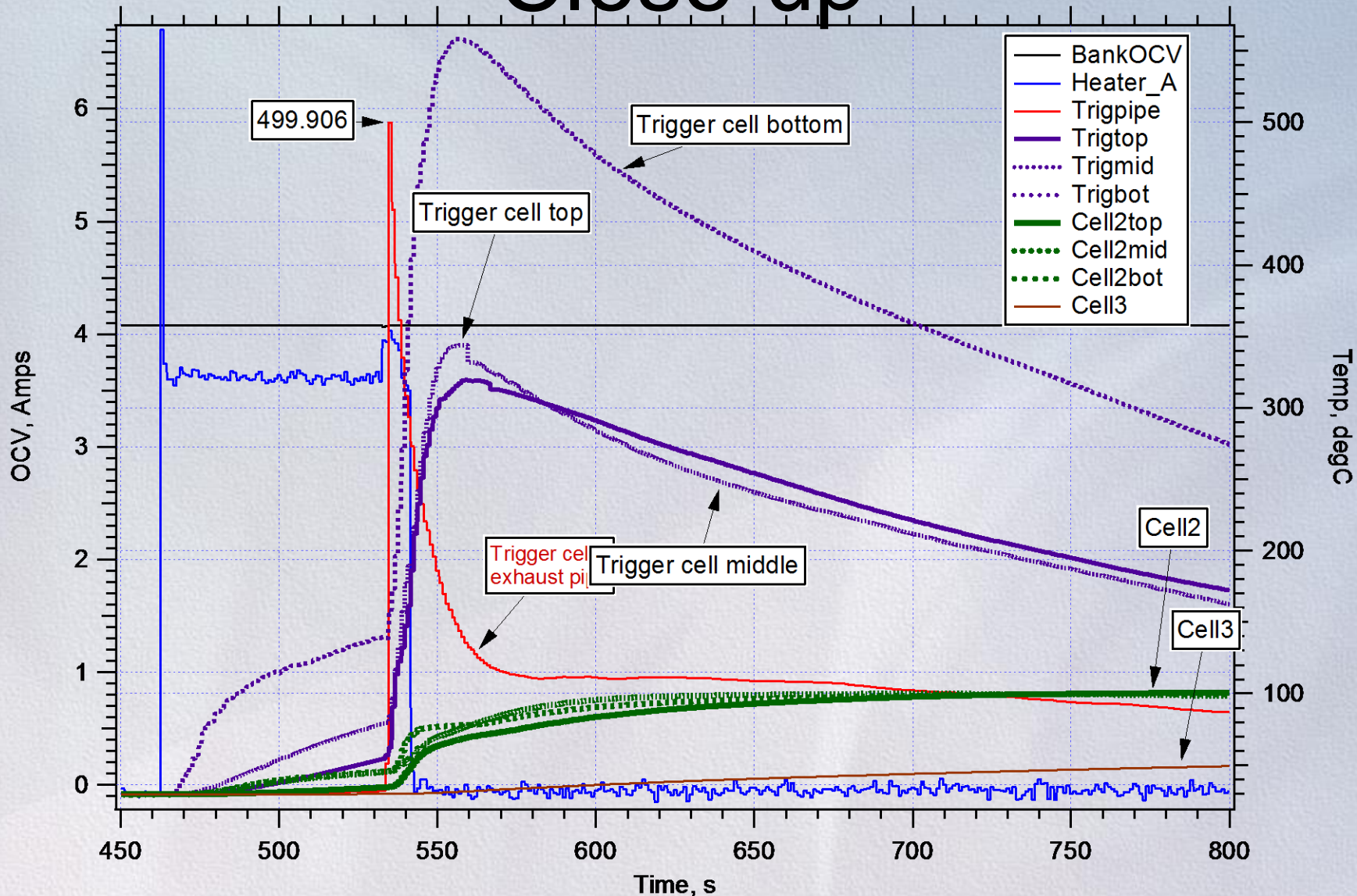

Trigger cell pipe exhaust peaks at 500°C

# Up even closer

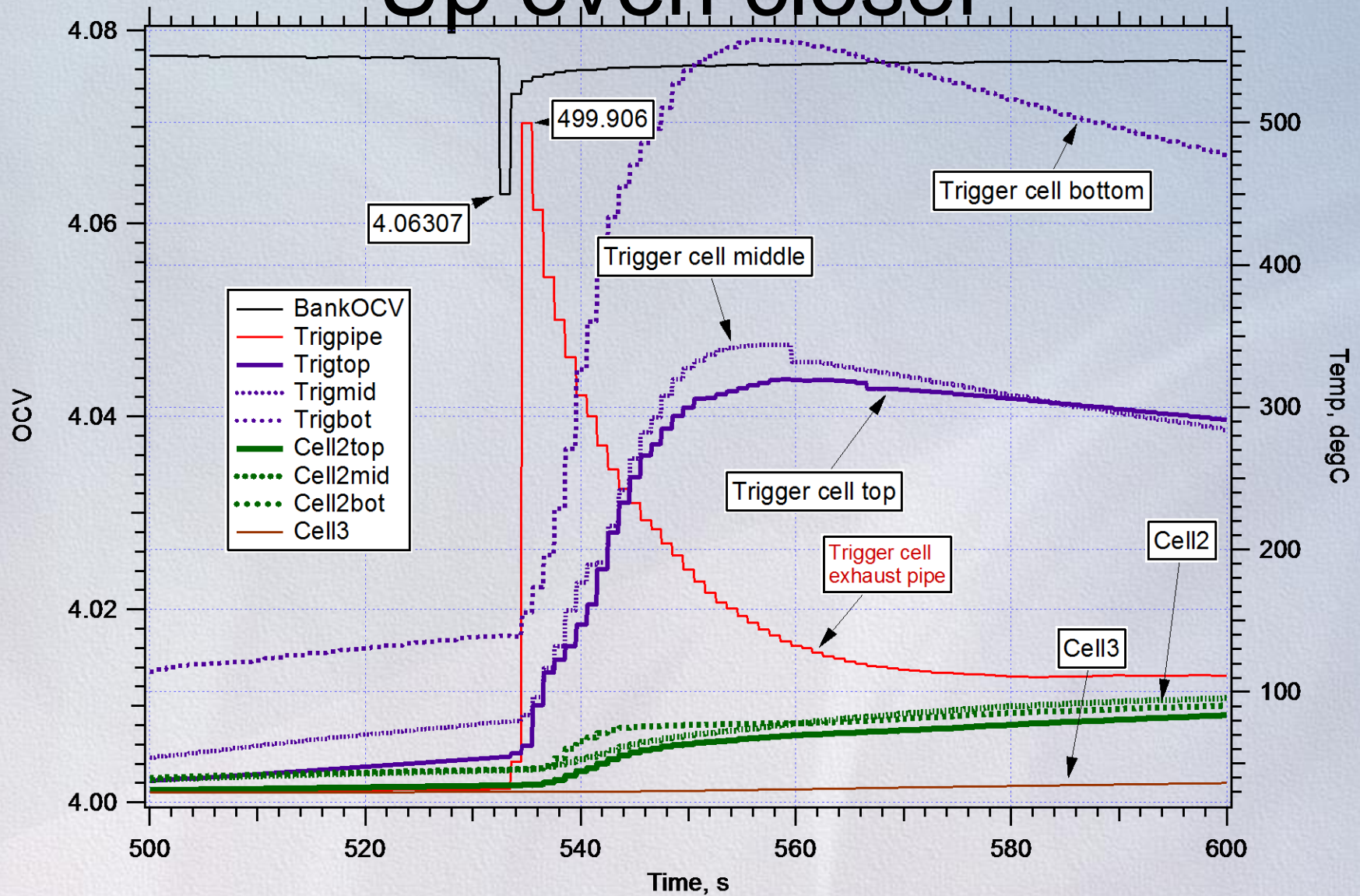

TR of trigger cell shorts the bank for ~1s, which blows open the positive & negative fuse of trigger cell, also positive link in cell 2 was found blown. The 15mV drop shown corresponds to 2.25A peak from the bank, not enough to blow 15A fusible links. But, data collected at 1Hz and may have missed true bottom of voltage dips.

# Trigger Cell Positive Fusible Link Opens

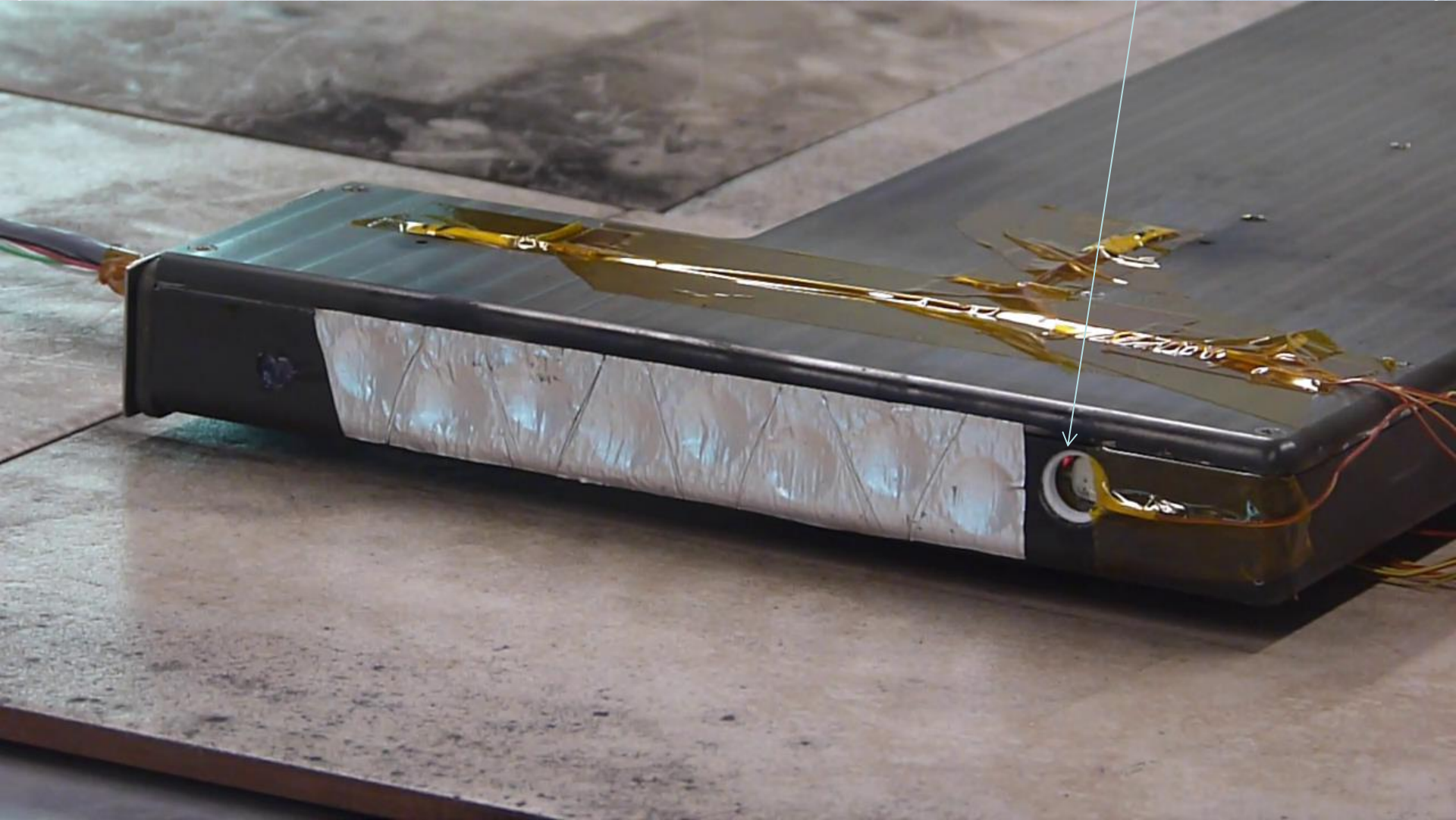

At video time 13m:18s

# Cell Venting

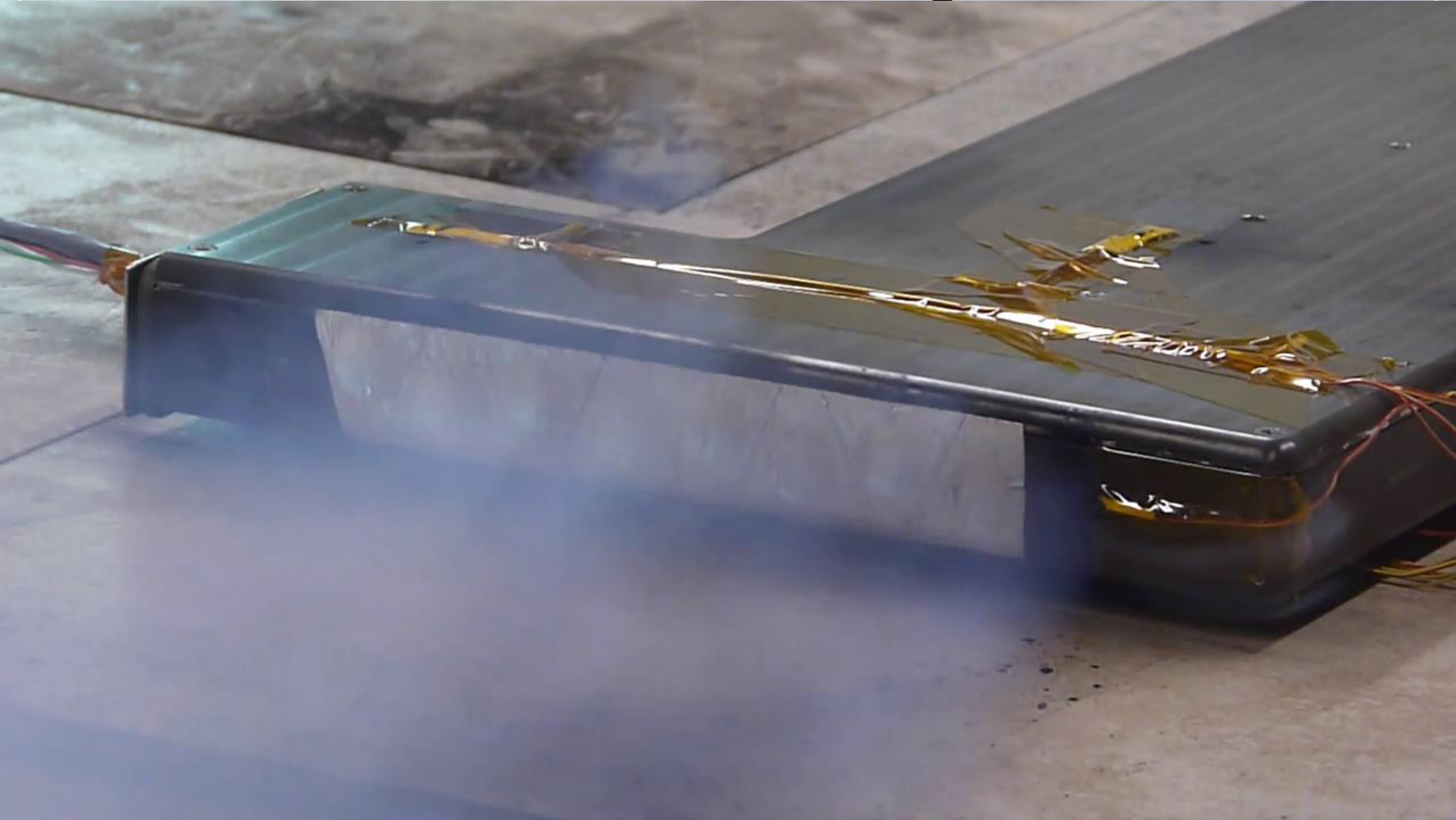

At video time 13m:19s

# Trigger Cell TR



At video time 13m:20s

# Post Test Photos

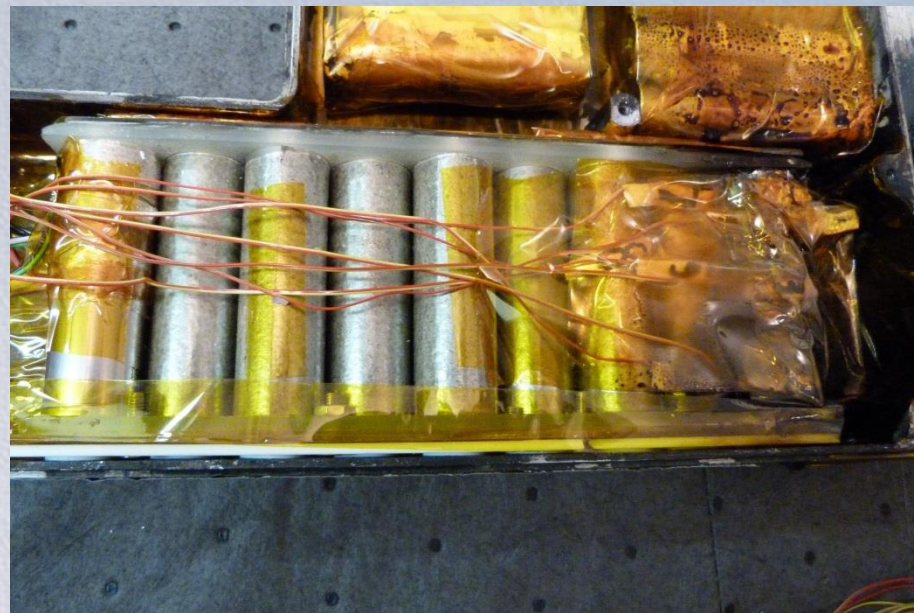

- Bank voltage at 4.07V
- Isolated Cell 2 voltage measured at 2.5V (blown positive fuse) on 8/27 and 1.1V on 8/29
  - Internal soft short suspected
- Megaohms measured between cell 4-9 cans and housing
- Negative fuse on trigger cell also found blown



# Preliminary Findings of Test

- TR of trigger cell was not uniformly hot
  - Only bottom TC > 500°C
  - Top and mid did not exceed 350°C
- Half of heater failed, yet TR reached in 72s
  - DPA of cell will determine if its internal temperatures exceeded melting temp of Al (660°C) and where besides the bottom.
- Data was not truly collected at 10 Hz
  - Limitation in the Labview data system makes it fail to increase data collection frequency
- Cell 2 Status
  - Cell 2 experienced an external short sufficient to blow its 15A positive fuse
  - No TR, but it subsequently experienced a soft internal short
    - Hopefully, DPA of cell will reveal why
    - Its hot tabs may have overheated portions of adjacent separator layers

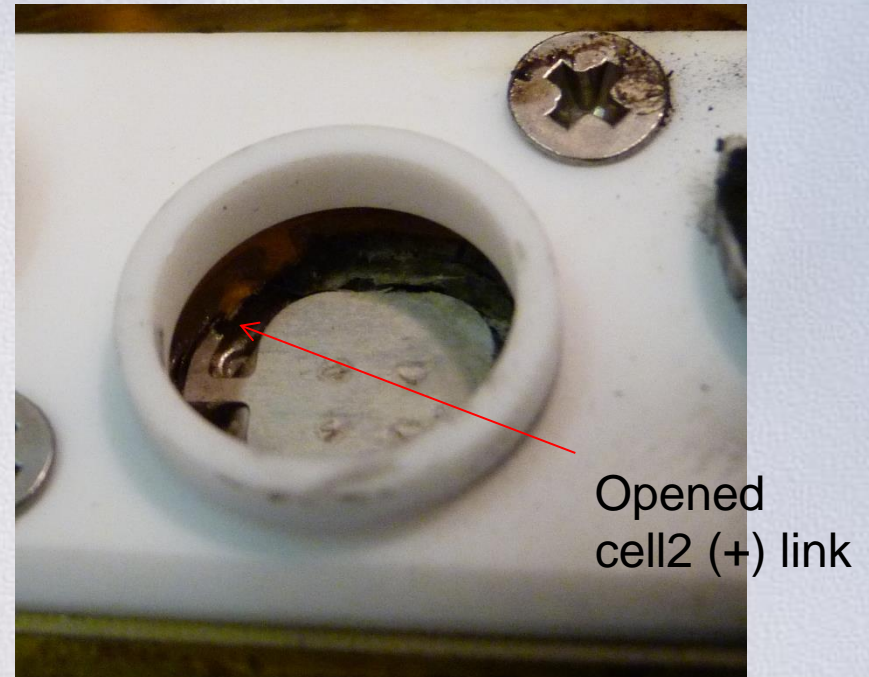

# DPA Resistance Measurements

- OCV of C2
  - 2.5V on 8/27 (hrs after run 53)
  - 1.1V on 8/29
  - 0V on 9/3
- Resistance (9/3)
  - C2+ to Trigcell can = 2 M $\Omega$
  - C2+ to C3 can = 10 M $\Omega$
  - C2+ to (-) bus = 13 M $\Omega$ 
    - C2 has very high internal resistance and is at 0% SoC
  - Trig+ to (+) bus = 0.35 $\Omega$ 
    - Ejecta bridge
  - C2+ to (+) bus = 8 M $\Omega$
- No remaining evidence that C2 was externally shorted
- DPA of Trigger cell & C2 next

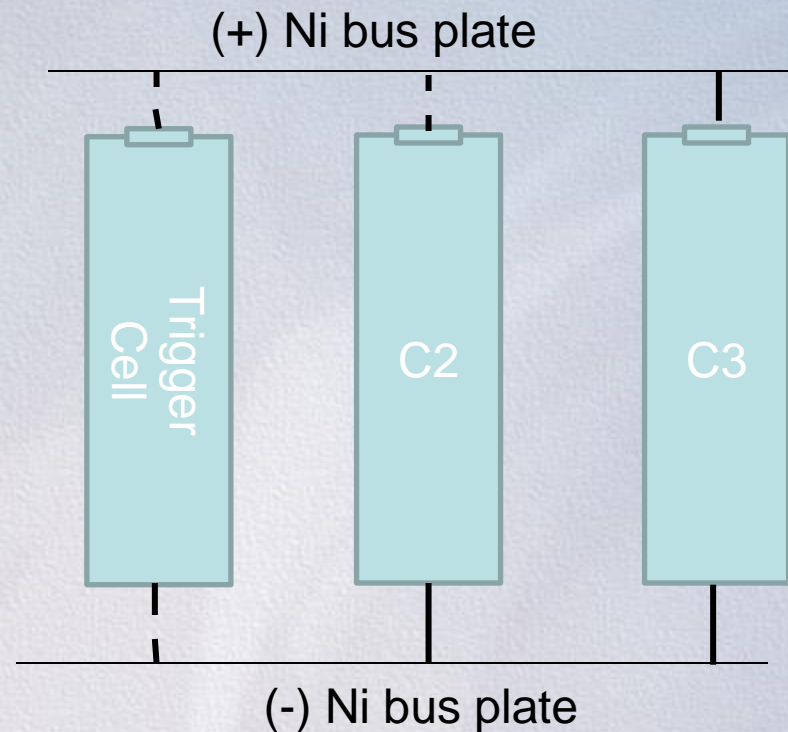

# LREBA2 9P Bank Design Features

- G10 capture plates with thread holes for fastening to housing and lid
- Ni bus strips with fusible links as narrow as 0.3mm with 4 sense tabs to make them interchangeable for each bank position
  - 6x6 mm lands for welding to cells
- 0.005" G10 Ni strip cover

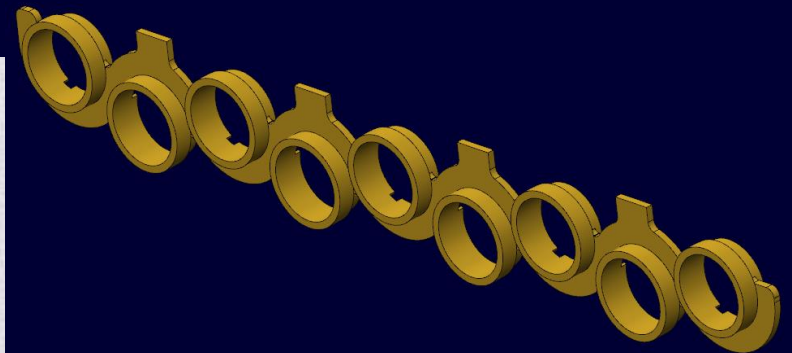
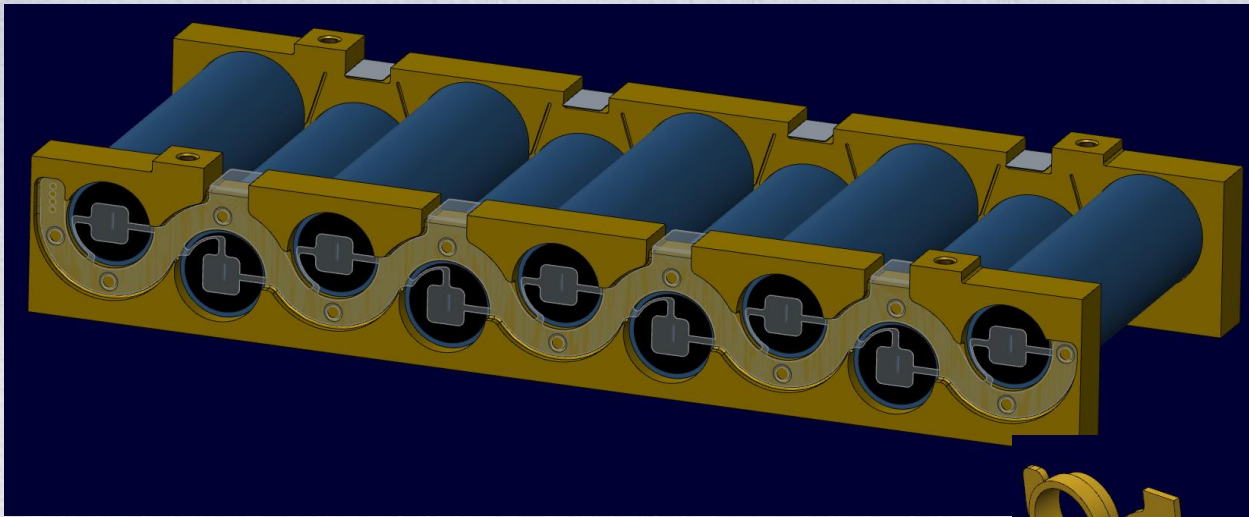

Macor cell ejecta pipe manifold compatible

# Fusible Link Verification Test

- Use G10 capture plates to seat the Ni bus plates and weld them to cells
- Use Ni bus tabs to put specified currents for blow tests
- Test new bus plate design at relevant conditions
  - With cells welded to the Ni bus plates
  - 0.3mm to be tested at 8A (+ 2 reps)
  - 0.4mm to be tested at 9A (+ 1 rep)
  - 0.5mm to be tested at 11A (+ 1 rep)
  - 0.6mm to be tested at 13A (+ 1 rep)

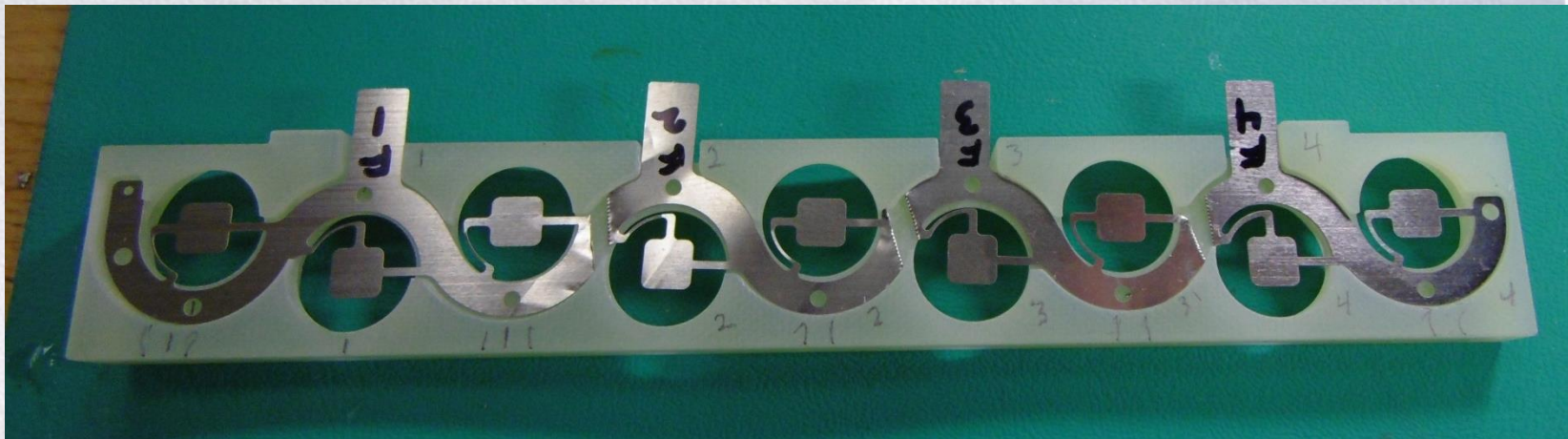
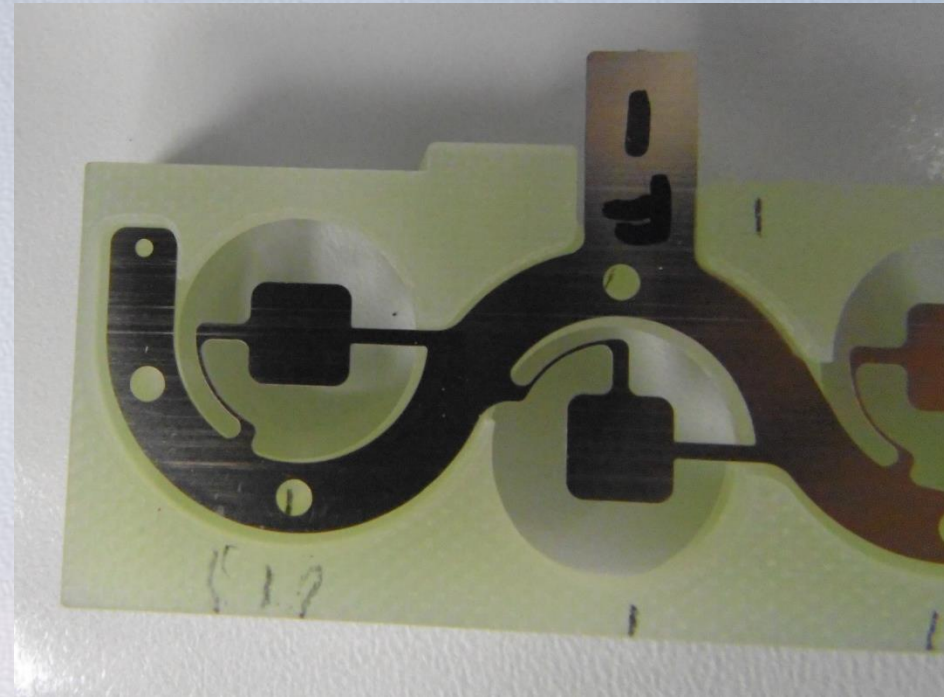

# Ambient Fusible Link Blow Tests



- 0.3mm links blew at 8A in ~1s
- 0.4mm links blew at 9A in ~2-7s
- 0.5mm links blew at 11A in ~2s
- 0.6mm links blew at 13A in ~15s

Fused open link (0.5mm)



Vacuum blow tests remain to be done

# Fusible Links in Action

- Cell voltage sense tabs routed under tile and terminated with fiberglass insulated wire
- 9P bank is immobilized with wire tie down to tile
- Heater LED functions
- Notes
  - bead of epoxy exist between each cell to promote thermal conduction
  - Negative fuses are rated at 7A
  - Positive fuses are rated at 8A

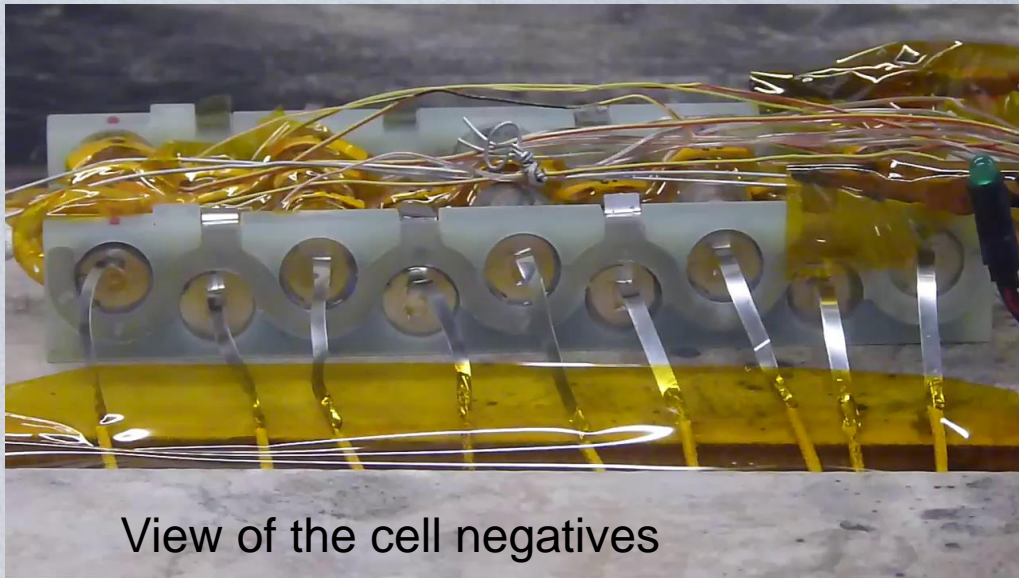

View of the cell negatives

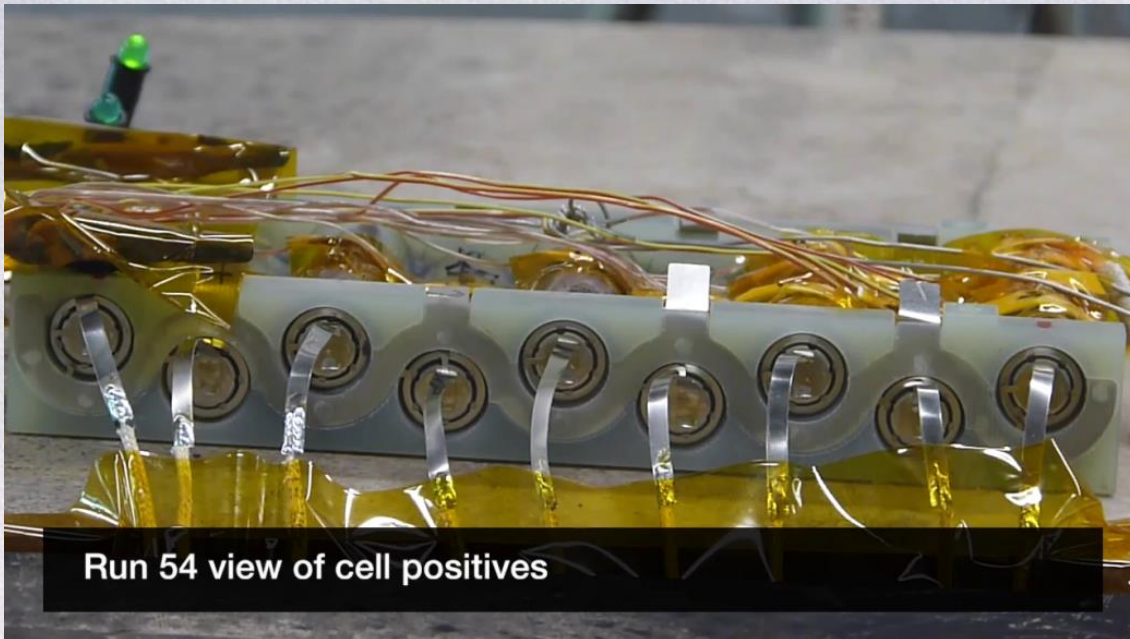

Run 54 view of cell positives

# Open Air 9P Fusible Links Test

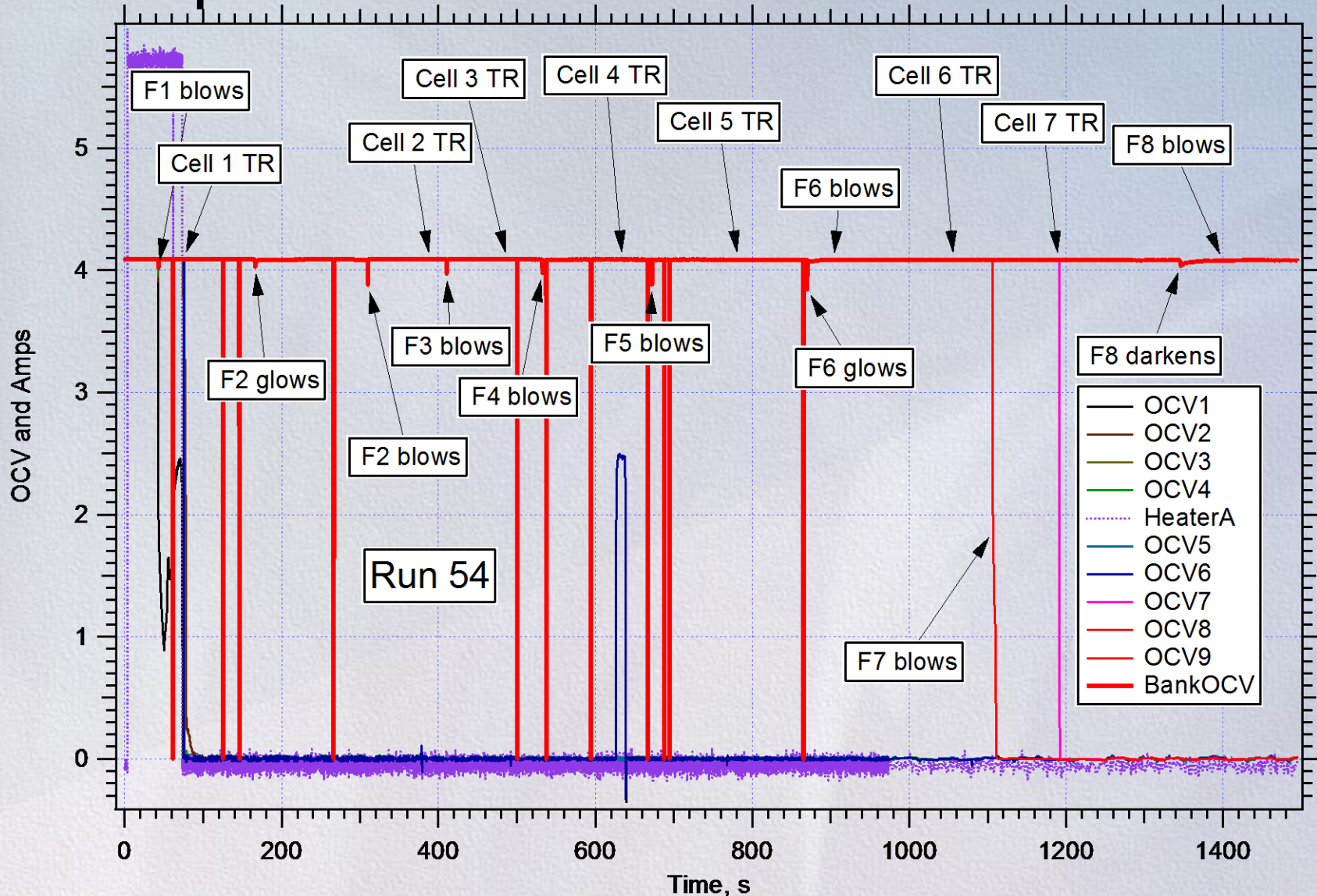

All bank voltage dives to zero volts last only 0.1s and probably due to noise  
 All longer lasting dips in bank voltage coincide with fuse events  
 Anomalous loss of OCV6 with TR of cell 1





# Timing of Video of Negatives

- Heater on 0:07
- **F1 blows** 0:47
- C1 pop 1:03
- C1 TR 1:17
- Heater off 1:17
- **F2 glows** 2:51
- **F2 blows** 5:14
- C2 pop 6:22
- C2 TR 6:23
- **F3 blows** 6:54
- C3 pop 8:01
- C3 TR 8:15
- **F4 blows** 9:01
- C4 pop 10:30
- C4 TR 10:41
- **F5 blows** 11:16
- C5 pop 11:35
- C5 TR 12:51
- **F6 glows** 14:34
- **F6 blows** 15:08
- C6 TR 18:04
- **F7 blows** 18:31
- C7 pop 18:50
- C7 TR 19:53
- **F8 blows** 23:28

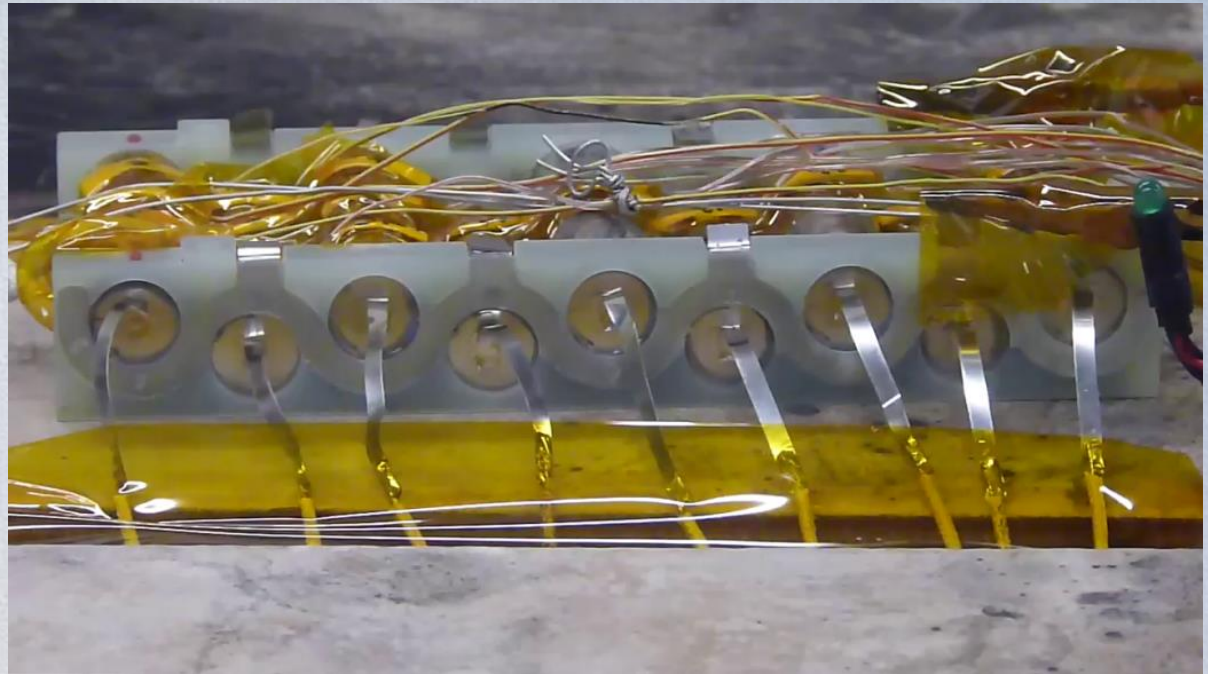

F6 glowing but not blowing

# Close up with temperatures

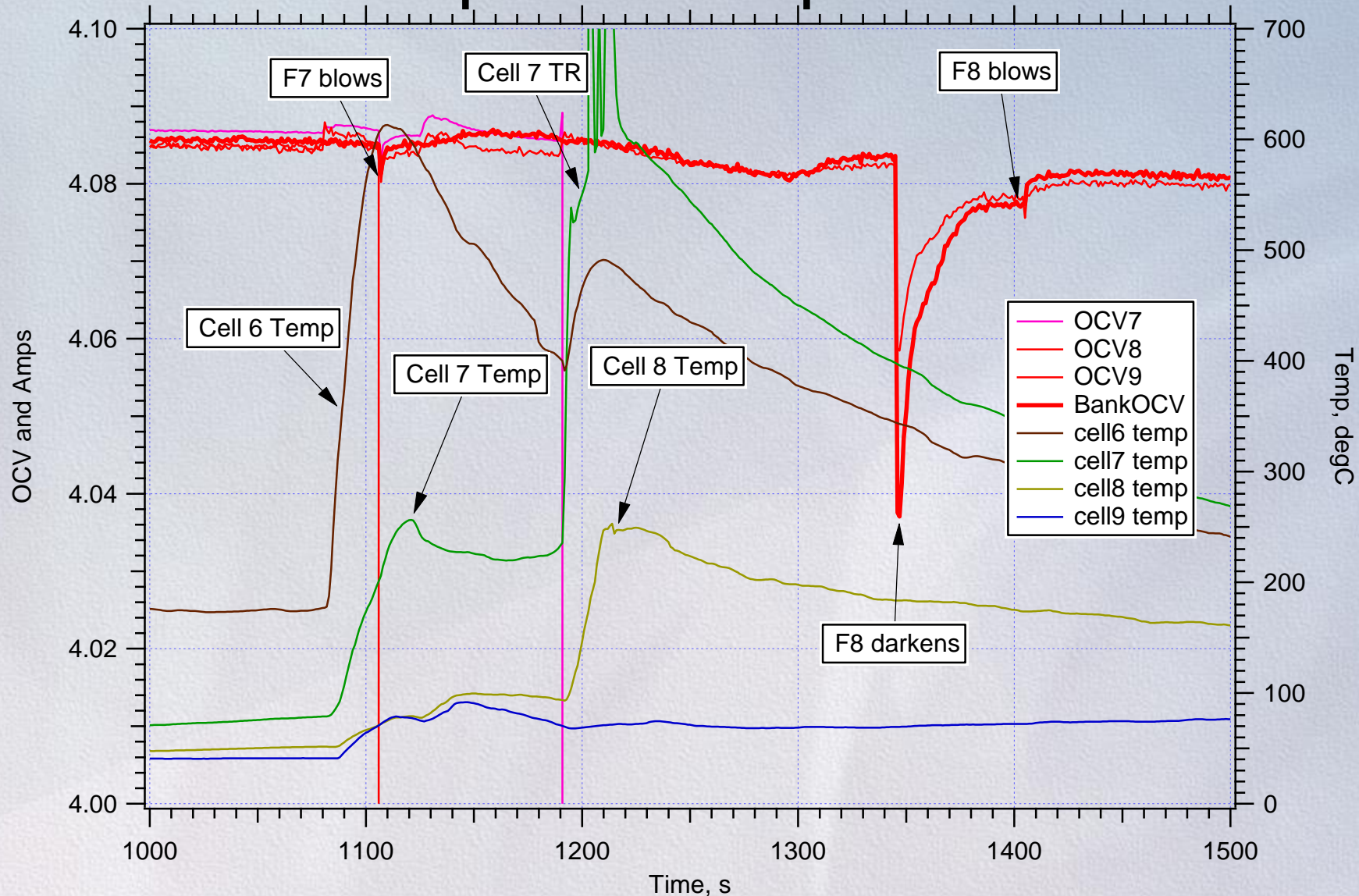

Cell 8 got just as hot as cell 7 prior to its TR. Not sure why propagation stopped after cell 7.

# Post Test Pictures

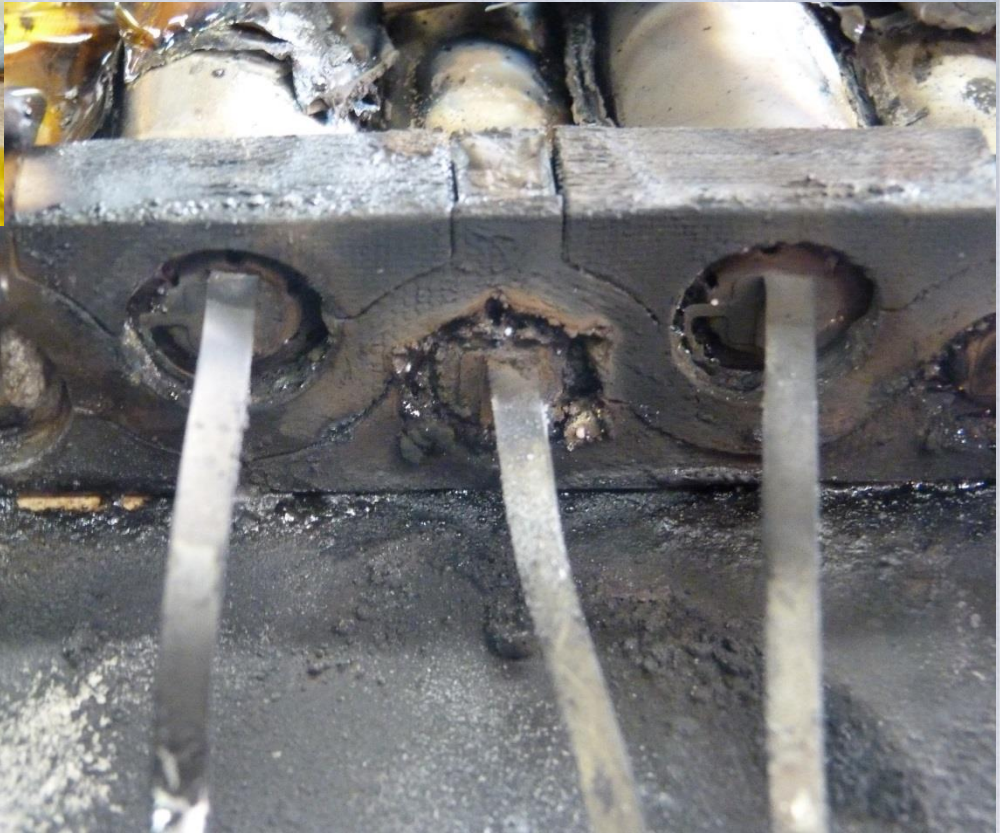
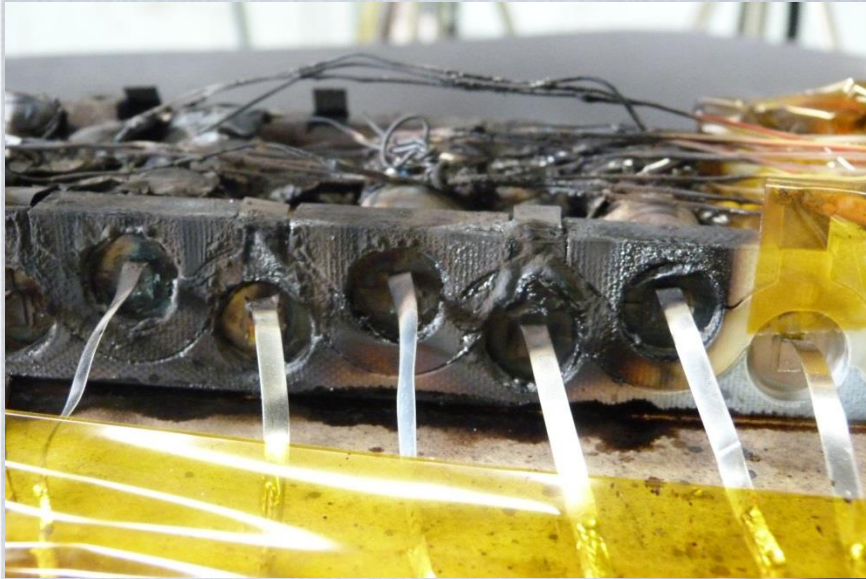

# Fusible Link Test Findings and Forward Plan

- Findings
  - TR propagated from cell 1 to cell 7 like dominos
  - Each cell TR events was proceeded with negative fuse blowing
  - Timing of bank OCV dips coincides with video timing of fuse glowing and blowing
  - Anomalous cell sense voltages drops to zero occurred
  - Nevertheless, we able to deduce that short circuit currents occur during the TR propagation process and fusible links are opened and should help mitigate propagation
- Questions
  - What caused the propagation to end at cell 7?
  - What caused OCV1, 2, 3, 4, 5, & 6 to dive to zero after C1 TR?
  - OCV bounce back of cell 8 indicates that it was exposed to an external short and did not experience an internal short
- Plan is to examine the test article and make resistance measurements.
  - Could the reflowed epoxy be electrically conductive?

# Upcoming Tests

- Trigger other end cell in full scale enclosure test
  - Trigger cell 9 from the same bank used in previous test
  - Collect data at 10 Hz
  - Get a TC secured on the inside of Macor pipe of trigger cell
    - Not the free air temp or inside diameter of housing hole
    - All other TC placements unchanged
- LLB TR Severity with baseline design
  - Existing design assessment test (Run 1) could be performed next week
- Further runs with LREBA2 parts due in by 9/12
  - Macor Pipe manifolds on order from TPI
  - Macor capture plates on order from Embree
  - Housing and lid order to be placed tomorrow
  - Planning populating battery with 5 banks with trigger cells to get statistically significant results
  - Need to work the impact to MLI garment designs on LREBA2

# Multi-Layer Insulation

- Will need to add soft goods bag over LREBA that tolerates the hot ejecta and disperses it
- Multi layer insulation may work
  - Example shown tolerated exposure on one side with little effect on the other side



# Lessons Learned To Date

- Design must prevent first TR propagation from initial failed cell
- Limiting cell to cell thermal conduction appears to work
  - Maximizing heat conduction between cells and enclosure may also work according to modelling
- Parallel cell bussing can provide significant in-rush currents into failed cell, which gets them hot
- Radiative energy transfer alone is not the dominant contributor to TR propagation
- Combustion of expelled electrolyte must directed away from adjacent cells
- Cell TR ejecta can bridge to adjacent cells and cause cascading shorts
- Most significant is control of cell vented/ejected products

# Acknowledgements

- Chris Iannello/NASA-NESC for funding both efforts
- Outstanding efforts of test team at JSC's Energy Test Area
  - Laura Baldwin
  - Dereck Lenoir
  - Tony Parish
  - Bill Holton
  - Pete Sanchez