



Turboelectric Aircraft Drive Key Performance Parameters and Functional Requirements

Ralph H. Jansen, Dr. Gerald V. Brown and James L. Felder

NASA Glenn Research Center, Cleveland, Ohio, 44135

and

Dr. Kirsten P. Duffy

University of Toledo, Toledo, Ohio, 43606

Introduction



- There is substantial interest in the investigation of improvements to aircraft by the introduction of electrical components into the propulsion system.
- In the case of a turboelectric aircraft the electrical systems can provide unmatched flexibility in coupling the power generation turbine(s) to the fan propulsors.
- This flexibility can result in reduced noise, emissions, and fuel burn.
- However, the greatly expanded electrical system introduces weight and efficiency burdens that oppose these benefits.
- A break-even analysis is presented here to determine the electrical power system performance level necessary to achieve a net benefit at the aircraft level.

Approach



- In order to conduct the break-even analysis we will define the key performance parameters, the key functional requirements, and the electrical power system boundary.
- Then we will formulate range equations for a base aircraft and a turboelectric version of that aircraft.
- Next we will find the range of possible benefits from a literature survey and calculate the weight and fuel burn costs.
- Finally, we find the break-even point by setting the ranges of the two aircraft types equal and using the same initial weight, operating empty weight, and payload weight and implicitly solving for the electric drive specific power and efficiency.
- The resulting parametric curves combined with the functional requirements will be used as input requirements for the electrical power system.

Drive System Selected for Evaluation



- A wide electric drive configuration trade space exists. Selected differentiating factors are the power source, the distribution approach, the number of motor-driven propulsors, and the fraction of the total propulsive power that is provided electrically.
- This analysis will evaluate the performance parameters of a **turboelectric** system where the system energy is stored as jet fuel. Therefore, the electrical drive considered here will be based on a turbine driving one or more electrical generators, motor driven propulsors, a power distribution system extending from the turbine to the propulsors, and a thermal management system. The power distribution includes power electronics, electrical cables, and protection devices.

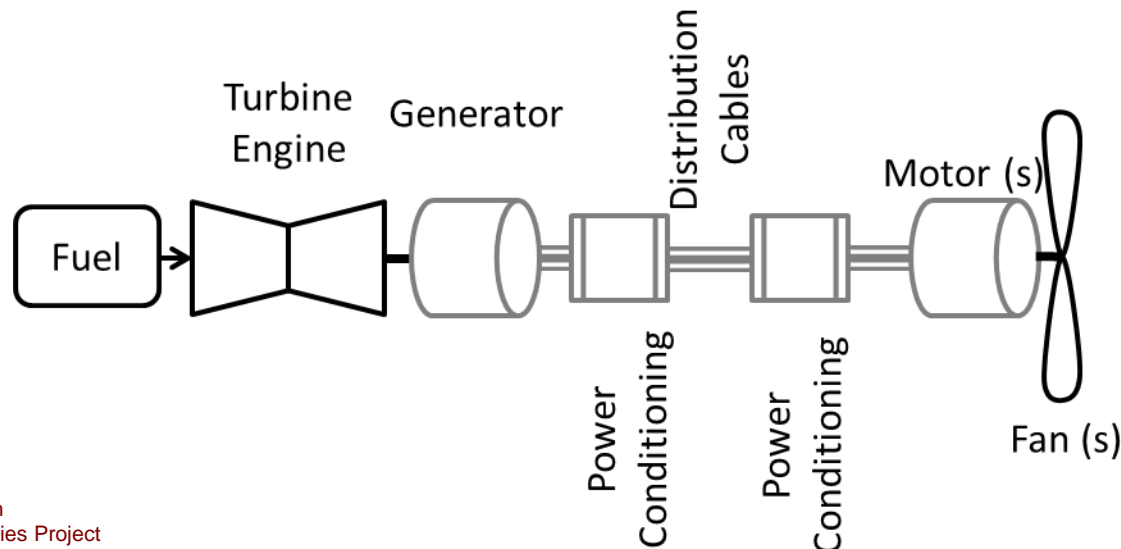

Electric Drive System Boundary



- The electric drive system boundary will include the electrical machines, the power management and distribution system, and the thermal system specifically related to heat removal in the two prior systems
- By this definition a representative turboelectric system would include generator(s), rectifier(s), distribution wiring, inverter(s), motor(s), and the thermal control for those components

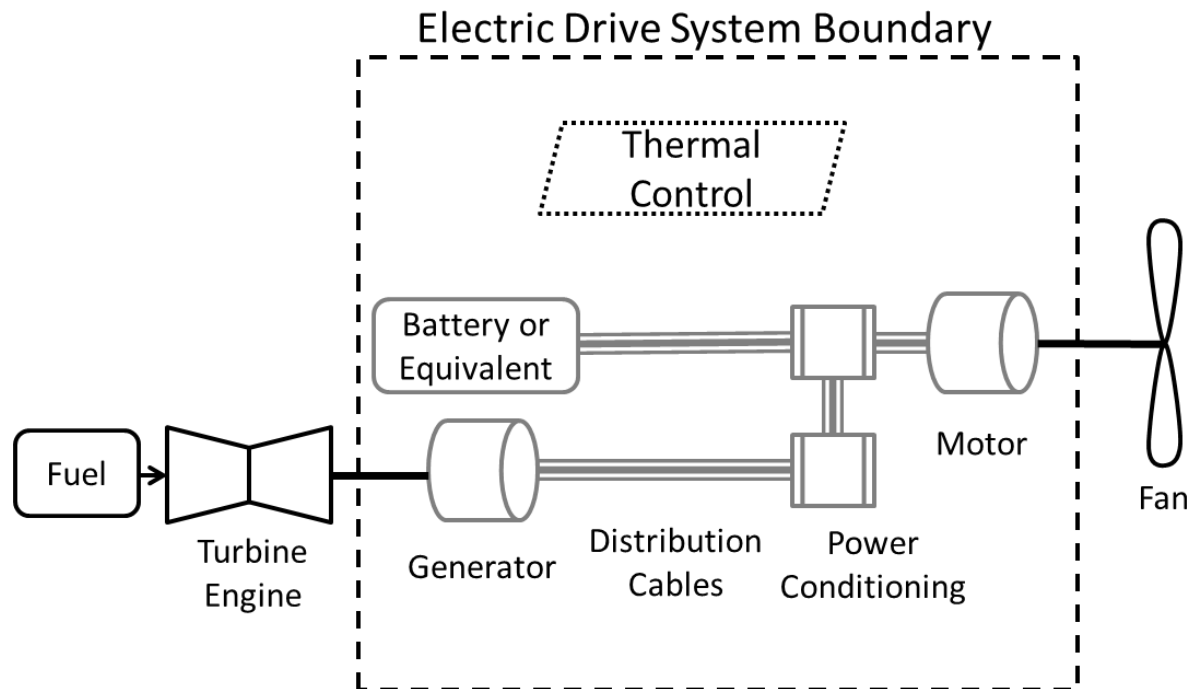

Key Performance Parameters



- Specific power (Sp_{ED}) and efficiency (η_{ED}) are proposed as the two KPPs of the electric drive system in a turboelectric aircraft.
- Specific power is the ratio of the rated power to the mass of the power system.
- Efficiency is the ratio of the output power to the input power of the power system.
- These quantities will be used to describe electrical power system performance and establish levels of performance necessary for successful aircraft.

Key Functional Requirements



- Distinct from the KPPs are the functional requirements of the electric drive system. Two of the crucial functional requirements for a turboelectric aircraft power system are independent speed and power control as well as redundancy and reliability levels.
- Independent speed and power control of individual fan propulsors is required in most proposed electric aircraft drive configurations and may enable configurations allowing
 - fan and turbine speed decoupling allowing optimal operation throughout the flight regime
 - yaw control through differential thrust
 - the ability to provide high-velocity wing blowing with controlled thrust
 - noise reduction strategies.
- Redundancy and reliability requirements are not yet well defined for an electric aircraft drive system; however, it is clear that the system must at least meet the safety standards that current aircraft propulsion systems meet.



Modified Breguet Range Equation

- The basis of the analysis is an expansion of the traditional terms in the Breguet range equation to include the efficiency and weight of the turboelectric drive.
- As such, it applies for situations where overall efficiency $\eta_{overall}$, lift-to-drag ratio L/D , and flight velocity are constant over the flight.
- Given these constraints, the range R_{AC} can be found if the initial ($W_{initial}$) and final weight (W_{final}) of the aircraft is known along with the fuel energy per unit mass h and the gravitational constant g .
- Although not true for the entire flight envelope, this description is a reasonable approximation for cruise conditions

$$R_{AC} = \frac{h}{g} \left(\frac{L}{D} \right) \eta_{overall} \ln \left(\frac{W_{initial}}{W_{final}} \right) \quad R_{EAC} = \frac{h}{g} \left(\frac{L}{D} \right)_{EAC} \eta_{overallEAC} \ln \left(\frac{W_{initialEAC}}{W_{finalEAC}} \right)$$

Modified Breguet Range Equation



- Breguet Range Equation

$$R_{AC} = \frac{h}{g} \left(\frac{L}{D} \right) \eta_{overall} \ln \left(\frac{W_{initial}}{W_{final}} \right)$$

- First, we expand the terms in the overall efficiency to include an electrical efficiency (η_{elec}) in addition to the thermal and propulsive efficiency

$$\eta_{overallEAC} = \eta_{thermEAC} \eta_{elec} \eta_{propEAC}$$

- Next, we recognize the additional weight of the electrical drive impacts both the initial and final weight of the turboelectric aircraft and expand each to explicitly account for the operating empty weight (W_{OEW}), payload weight (W_{pay}), and fuel weight ($W_{fuelEAC}$).

$$W_{initialEAC} = W_{OEW} + W_{pay} + W_{fuelEAC} + W_{elec}$$

$$W_{finalEAC} = W_{OEW} + W_{pay} + W_{elec}$$

- The turboelectric range equation is now stated, recognizing that the turboelectric system will have different L/D , thermal efficiency, propulsive efficiency, initial weight, and final weight compared to the base aircraft.

$$R_{EAC} = \frac{h}{g} \left(\frac{L}{D} \right)_{EAC} \eta_{overallEAC} \ln \left(\frac{W_{initialEAC}}{W_{finalEAC}} \right)$$

Fuel Burn Benefit Ranges from Literature



- Higher propulsive efficiency due to increased bypass ratio (BPR), higher propulsive efficiency due to boundary layer ingestion, and lift to drag ratio improvements have been frequently cited as enabled by turboelectric propulsion.
- Introduction of an electric drive system between the turbine and fan, allowing decoupling of their speeds and inlet-to-outlet area ratios. With this approach, high BPR can be achieved since any number and size of fans can be driven from a single turbine. Increasing BPR results in improved propulsive efficiency
- Boundary layer ingestion (BLI) increases propulsive efficiency by ingesting lower velocity flow near the airframe into the propulsors, reenergizing the wake and thereby reducing drag. BLI can be implemented on both conventional tube and wing and HWB aircraft
- Distributed propulsion is expected to improve both lift and L/D through wing flow circulation control. Improvements in L/D may result in smaller wing area and reduced drag and weight

	Propulsive		
	BPR, percent	BLI, percent	L/D, percent
Minimum	4	3	0
Median	6	5.5	4
Maximum	8	8	8

Weight Impacts as a function of KPPs



Electric Drive Specific Power Impact

- Weight of electric drive is found by
 - Thrust at initial cruise is found by force balance
 - Beginning of cruise power is product of cruise thrust and cruise velocity
 - Takeoff power is estimated by ratios of cruise and takeoff parameters

$$\alpha = \left(\frac{T_{takeoff}}{T_{cruise}} \right) \left(\frac{v_{takeoff}}{v_{cruise}} \right)$$

- Weight impact is a function of
 - initial aircraft weight
 - Cruise velocity
 - the electric drive specific power
 - propulsive efficiency
 - electrical efficiency.

$$W_{elec} = \frac{W_{initialEAC} v_{cruise} \alpha / Sp_{ED}}{\left(\frac{L}{D} \right)_{EAC} \eta_{elec} \eta_{propEAC}}$$

Electric Drive Efficiency Impact

- The weight penalty of the additional fuel resulting from the electrical drive losses is estimated by introducing the additional electrical inefficiency term into the overall efficiency, then holding all parameters on the base aircraft fixed.
- Using these assumptions we can find the change in fuel weight from the difference of original fuel weight divided by the electrical efficiency, less the original fuel weight

$$\Delta W_{fuel} = W_{fuel} \left(\frac{1}{\eta_{elec}} - 1 \right)$$

Weight Impacts of Electric Drive System



95% eff weight breakout

90, 95, 99% weights

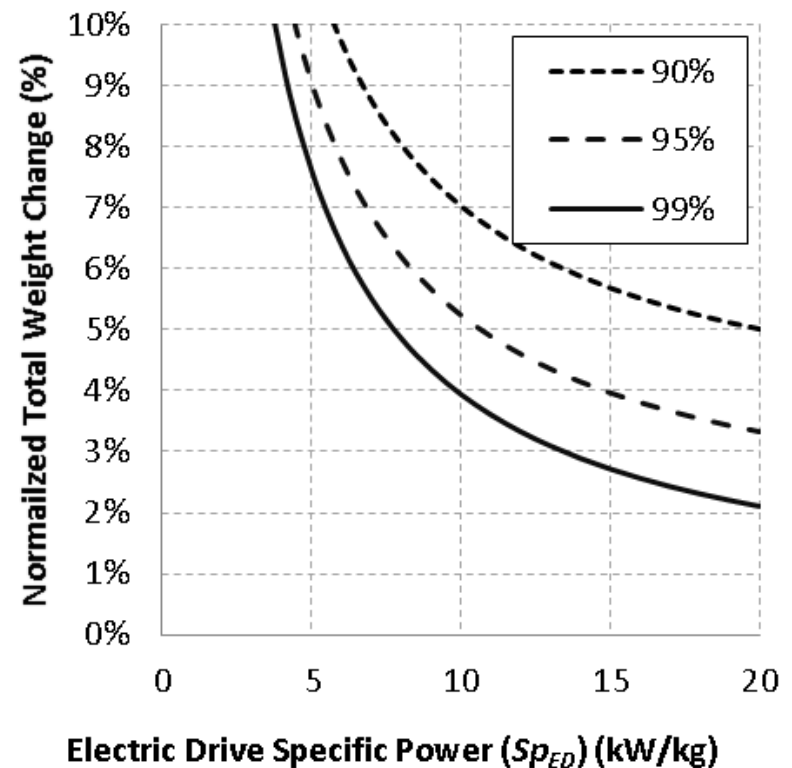
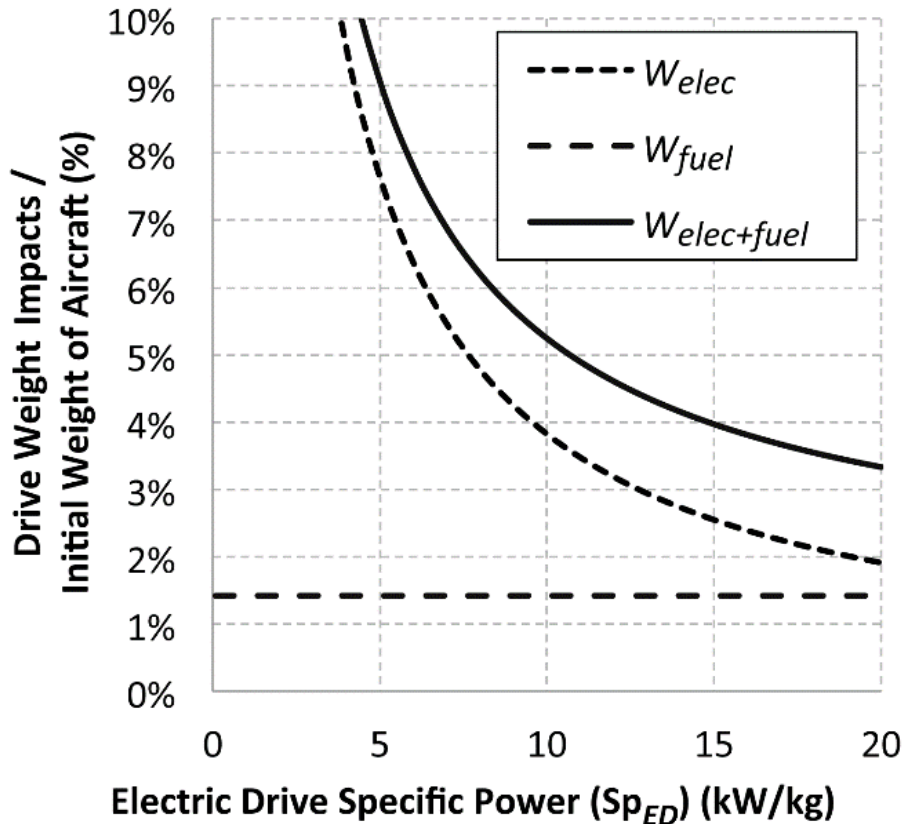

$$\frac{W_{elec} + \Delta W_{fuel}}{W_{initial}} = \frac{v_{cruise} \alpha / Sp_{ED}}{\left(\frac{L}{D}\right)_{EAC} \eta_{elec} \eta_{propEAC}} + \zeta_{AC} \left(\frac{1}{\eta_{elec}} - 1 \right)$$

Fuel Burn Impact of Electric Drive



- The increased fuel burn is estimated as the sum of the drive efficiency cost and the normalized weight change.
- The basic assumption is that a 1% weight gain on the aircraft results in a 1% increase in required fuel as justified by the aircraft force balance. A 1% increase in weight results in a 1% increase in thrust required. Holding the aircraft parameters fixed also results in a 1% increase in fuel burn.

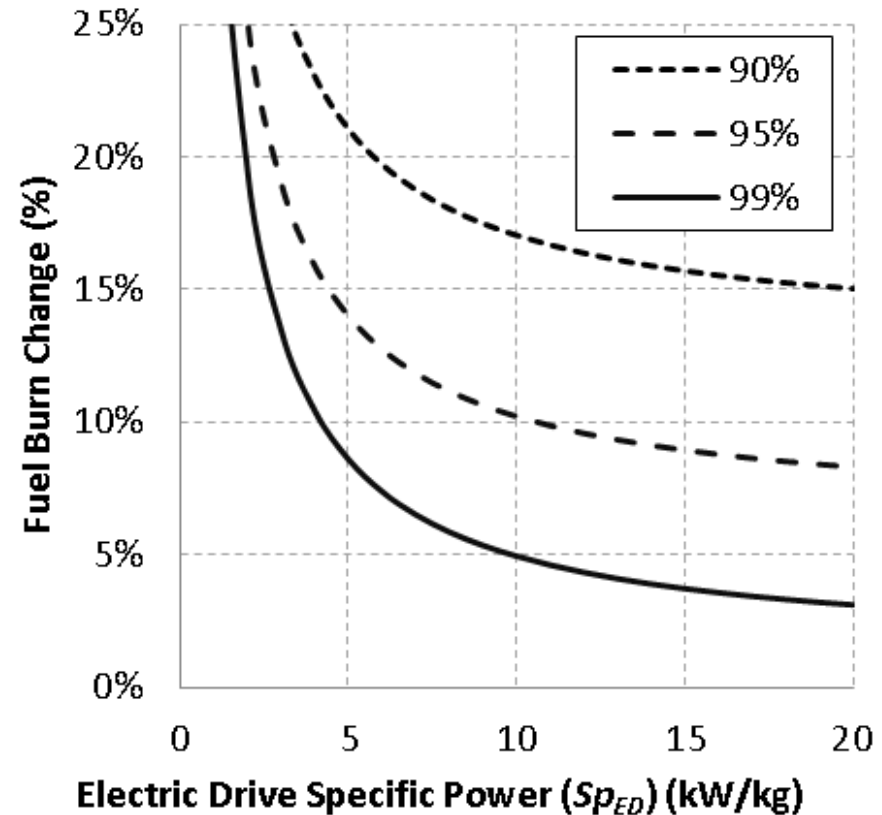



Breakeven Analysis

- The break-even analysis determines the electric drive specific power and efficiency where the costs of adding the drive exactly equal the benefits.
- Base aircraft and turboelectric aircraft performance parameters are constant in this analysis.
- The breakeven equation is found by
 - First, the range expressions of the base aircraft and the turboelectric aircraft are equated
 - Then the common terms are canceled and the efficiency terms expanded
 - Next, the terms are arranged so the benefits are on left and costs are on the right with expanded weight terms
 - Finally, the electrical drive weight as function of specific power, and the aircraft parameters are included
- Breakeven lines are found by implicitly solving equation balancing the costs and benefits across a range of specific powers at a expected benefit level

$$\underbrace{\left(\frac{L}{D}\right)_{\text{aero}}}_{\text{benefits}} \underbrace{\frac{\eta_{\text{therm}}}{\eta_{\text{thermEAC}}} \frac{\eta_{\text{prop}}}{\eta_{\text{propEAC}}}}_{\text{propulsive benefits}} = \underbrace{\frac{\eta_{\text{elec}}}{\text{electrical efficiency}}}_{\text{cost}} \underbrace{\frac{\ln\left(\frac{W_{\text{initial}}}{W_{\text{OEW}} + W_{\text{pay}} + \frac{W_{\text{initial}} v_{\text{cruise}} \alpha}{\left(\frac{L}{D}\right)_{\text{EAC}} \eta_{\text{propEAC}} \eta_{\text{elec}} Sp_{\text{ED}}}}\right)}{\ln\left(\frac{W_{\text{initial}}}{W_{\text{OEW}} + W_{\text{pay}}}\right)}}_{\text{weight cost from specific power and efficiency}}$$



Breakeven Results

- Along the break-even line, the fuel weight reduction is equal to the additional electric drive weight. The fuel burn along this line is less than that of the base aircraft.
- If the system has KPP parameters in the region above the curve, the overall system will close with a reduction in the combined fuel and drive weight, which can be taken as payload or some alternate benefit.
- The figure shows the specific power and efficiency relationship using the median-level benefit estimates, cruise velocity of 0.8M and 0.27 base aircraft fuel fraction
- With these assumptions, the minimum required drive specific power must be approximately 9 kW/kg if the system is 100% efficient and the minimum required efficiency is 92% at a specific power of 20 kW/kg.

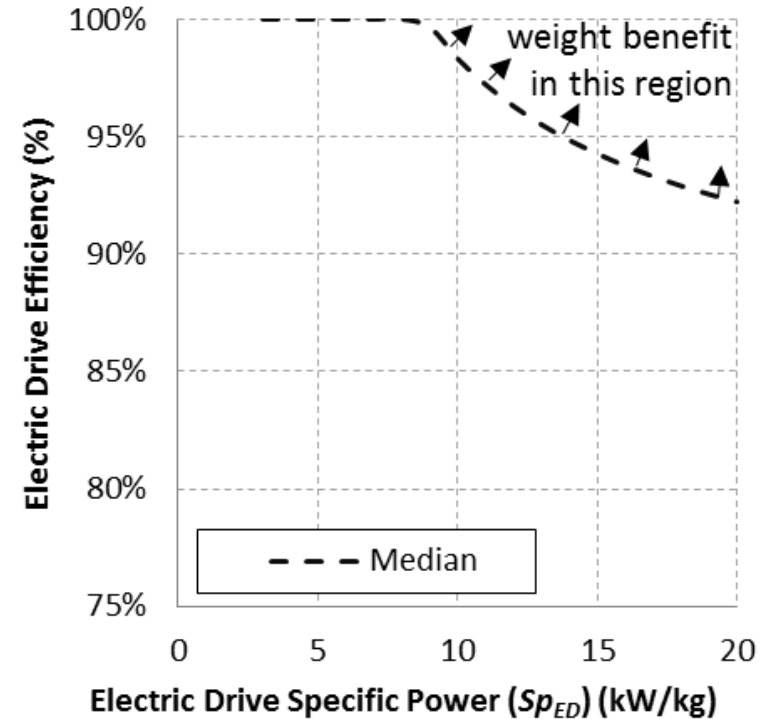

	Propulsive		
	BPR, percent	BLI, percent	L/D, percent
Minimum	4	3	0
Median	6	5.5	4
Maximum	8	8	8

	L/D	$\eta_{prop, \eta_{propEAC}}$	Benefit Product
Base Aircraft	17	0.6	
Min. Turboelectric	17	0.64	0.93
Med. Turboelectric	17.7	0.67	0.86
Max. Turboelectric	18.4	0.70	0.79

$$\frac{\left(\frac{L}{D}\right)_{aero}}{\left(\frac{L}{D}\right)_{EAC}} \frac{\eta_{therm}}{\eta_{thermEAC}} \frac{\eta_{prop}}{\eta_{propEAC}} = \frac{\eta_{thermEAC} \eta_{propEAC}}{\text{propulsive benefits}}$$



Breakeven Results

- The figure is a plot of the break-even curves for the three levels of benefit assumptions.
- Not surprisingly, if the benefits are large, the KPPs of the power system do not need to be as aggressive.
- If the benefits are small, the KPP requirements become substantially more difficult.
- The minimum required specific power is reduced 6kW/kg and the minimum efficiency to around 85% at 20kW/kg when using the most favorable benefit assumptions.

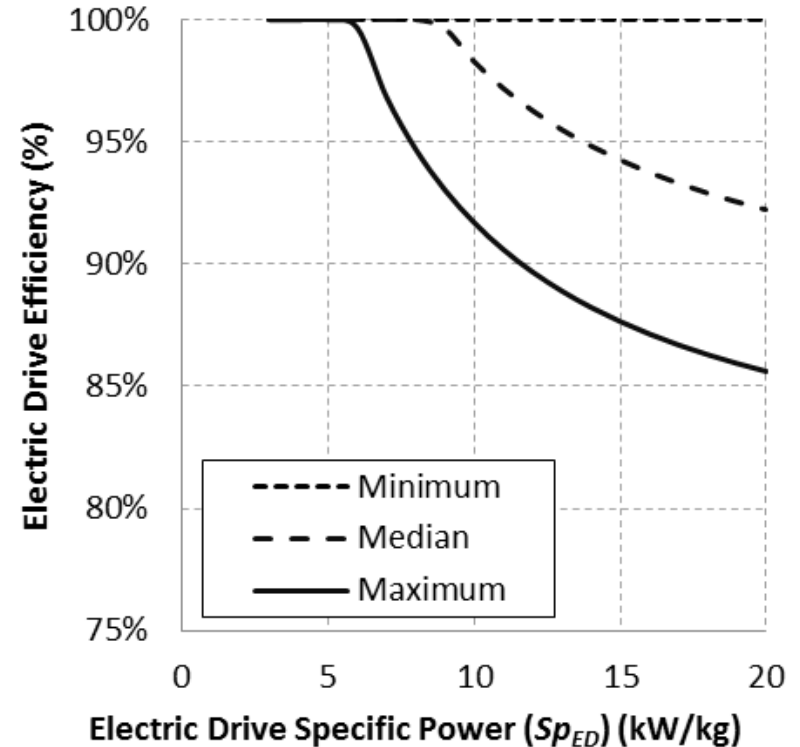

	Propulsive		
	BPR, percent	BLI, percent	L/D, percent
Minimum	4	3	0
Median	6	5.5	4
Maximum	8	8	8

	L/D	$\eta_{prop, \eta_{propEAC}}$	Benefit Product
Base Aircraft	17	0.6	
Min. Turboelectric	17	0.64	0.93
Med. Turboelectric	17.7	0.67	0.86
Max. Turboelectric	18.4	0.70	0.79

$$\frac{\left(\frac{L}{D}\right)_{aero}}{\left(\frac{L}{D}\right)_{EAC}} \frac{\eta_{therm}}{\eta_{thermEAC}} \frac{\eta_{prop}}{\eta_{propEAC}} = \frac{\eta_{thermEAC} \eta_{propEAC}}{\text{propulsive benefits}}$$

Conclusions



- Specific power and efficiency are proposed as two key performance parameters for the electric drive system of a turboelectric aircraft.
- The costs were associated with the proposed KPPs. Analysis of the costs leads to the conclusion that below a specific power of approximately 5 kW/kg, the specific power is the dominant cost, whereas above that level the efficiency becomes dominant. Additionally it is noted that the fuel burn cost can never be less than the inefficiency of the electric drive system.
- A breakeven equation was developed by using range equations for a base air craft and a turboelectric aircraft. It was developed in a form which separated the costs and benefits of the system.
- KPP break-even weight curves were found for the minimum, median, and maximum turboelectric benefit cases and the region of power system performance that will result in a net weight benefit is shown.
- Further work will need to be done to define the net fuel burn benefit region and consider hybrid or all electric configurations.