

Altitude Compensating Nozzle

Project Manager(s)/Lead(s)

Joseph H. Ruf/ER42
(256) 544-4942

Daniel Jones/AFRC/RA
(661) 276-3498

Sponsoring Program(s)

Space Technology Mission Directorate
Game Changing Development

Project Description

The dual-bell nozzle (fig. 1) is an altitude-compensating nozzle that has an inner contour consisting of two overlapped bells. At low altitudes, the dual-bell nozzle operates in mode 1, only utilizing the smaller, first bell of the nozzle. In mode 1, the nozzle flow separates from the wall at the inflection point between the two bell contours. As the vehicle reaches higher altitudes, the dual-bell nozzle flow transitions to mode 2, to flow full into the second, larger bell. This dual-mode operation allows near optimal expansion at two altitudes, enabling a higher mission average specific impulse (I_{sp}) relative to that of a conventional, single-bell nozzle. Dual-bell nozzles have been studied analytically and subscale nozzle tests have been completed.¹ This higher mission averaged I_{sp} can provide up to a 5% increase² in payload to orbit for existing launch vehicles. The next important step for the dual-bell nozzle is to confirm its potential in a relevant flight environment. Toward this end, NASA Marshall Space Flight Center (MSFC) and Armstrong Flight Research Center (AFRC) have been working to develop a subscale, hot-fire, dual-bell nozzle test article for flight testing on AFRC's F15-D flight test bed (figs. 2 and 3). Flight test data demonstrating a dual-bell ability to control the mode transition and result in a sufficient increase in a rocket's mission averaged I_{sp} should help convince the launch service providers that the dual-bell nozzle would provide a return on the required investment to bring a dual-bell into flight operation. The Game Changing Department provided 0.2 FTE to ER42 for this effort in 2014.

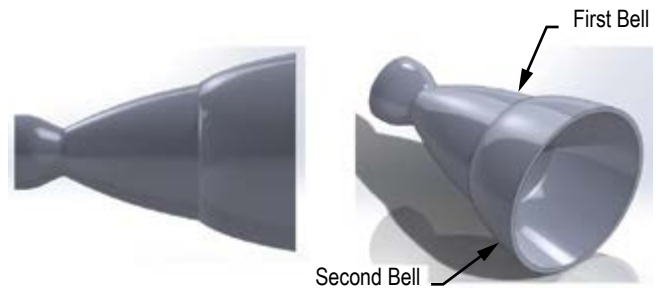

Figure 1: Front and isometric view of a dual-bell nozzle.



Figure 2: F-15 with the PFTF.

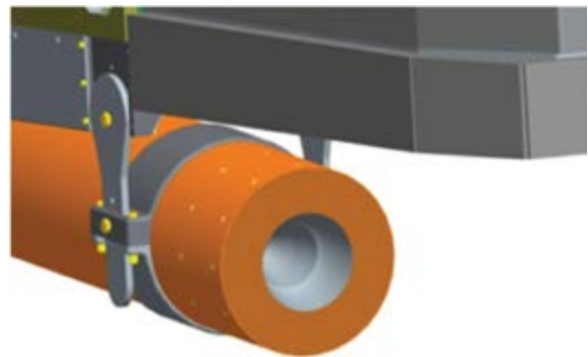

Figure 3: Aft end view of the PFTF with dual-bell installed.

Anticipated Benefits

The benefit of the larger dual-bell, multiyear task will be a dual-bell nozzle design that is capable of being controlled to the degree that launch vehicle systems require. Launch vehicle guidance, navigation, and control (GN&C) requires exacting and direct control over the thrust performance of rocket engines. Dual-bell nozzles in their simplest form, just the two bell contours, would likely not produce sufficiently predictable thrust versus altitude because the transition from mode 1 to mode 2 will be affected by the variation of vehicle base pressure, among other things. This multiyear task will develop methods to enable explicit control over the mode transition, thereby providing the launch vehicle GN&C the necessary control over the rocket engine's delivered thrust.

Potential Applications

A dual-bell nozzle, in theory, would provide benefit for rocket-powered vehicles, such as launch vehicles, that experience large changes in ambient pressure. In addition, dual-bell nozzles can be used for weapons systems that have high thrust requirements for launch, requiring high main chamber pressure, but then need efficient propulsion at much lower chamber pressures while loitering.

Notable Accomplishments

With the 0.2 FTE provided by the Game Changing Project, Mr. Ruf was able to continue working with his AFRC counterparts to size the dual-bell nozzle flight test article and develop an approach to create the large changes in nozzle pressure ratios. A short summary of the 2014 work completed is provided here. A fuller description of the 2014 work can be found in an AIAA paper³ and a companion NASA TM.⁴ First, a representative Space Transportation System trajectory was used to explain how a dual-bell could be integrated into a launch vehicle system and where the I_{sp} benefits were gained. The expected methods for controlling the mode transition during ascent were explained. The first flight test article's (a cold flow test article) throat diameter was sized via a trades study on mass flow rates, thrust derived, and test run time. The objective was to size the test article to enable testing at both the MSFC Nozzle Test Facility (NTF) and on the F-15D flying test bed. The nozzle area ratio of the two bell nozzles were

sized to fit within the NTF's altitude simulation capability and the flight envelope of the F-15D while still retaining traceability to a full-scale, dual-bell nozzle. A testing protocol for the test article's chamber pressure was then developed to simulate the changes in the nozzle pressure ratio of a launch vehicle trajectory in the 4 to 6 s of test time available on the F-15D flights. These forced nozzle pressure ratio changes on the flight test will be required to show that the dual-bell nozzle transitions can be controlled during a launch vehicle accent.

References

1. Ruf, J.; McDaniels, D.; and Nguyen, T.: "Dual Bell Nozzle Cold Flow Test Data: Nozzle Performance and Wall Pressure Data," JANNAF Joint Meeting, Charleston, SC, June 2005.
2. Schneider, D.; Génin, C.; Stark, R.; and Fromm, C.: "Ariane 5 Performance Optimization Using Dual Bell Nozzle Extension," German Aerospace Center, DLR, Institute of Space Propulsion Lampoldshausen, Germany, D-74239, 2014.
3. Jones, D.; Ruf, J.; Bui, T.; et al.: "Conceptual Design for a Dual-Bell Rocket Nozzle System Using a NASA F-15 Airplane as the Flight Test-bed," AIAA-2014-3956, 50th AIAA/ASME/SAE/ASEE Joint Propulsion Conference, Cleveland, OH, doi: 10.2514/6.2014-3956, July 28–30, 2014.
4. Jones, D.; Ruf, J.; Bui, T.; et al.: "Conceptual Design for a Dual-Bell Rocket Nozzle System Using a NASA F-15 Airplane as the Flight Test-bed," NASA/TM—2014–218376, NASA Marshall Space Flight Center, Huntsville, AL, October 2014.