

Comparison of three-dimensional *in situ* observations and phase-field simulations of microstructure formation during directional solidification of transparent alloys aboard the ISS

Kaihua Ji¹, F.L. Mota², Y. Song¹, J. Pereda², T. Lyons³, L.L. Strutzenberg⁴, R. Trivedi³, N. Bergeon², A. Karma¹



¹Northeastern University

²IM2NP, Aix-Marseille Université

³Iowa State University

⁴Marshall Space Flight Center



The system – directional solidification

- Microstructure formation under well-controlled growth conditions (G , V , C_0)

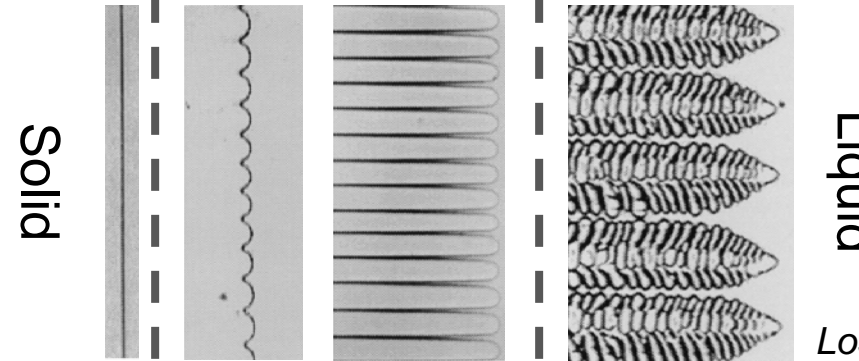
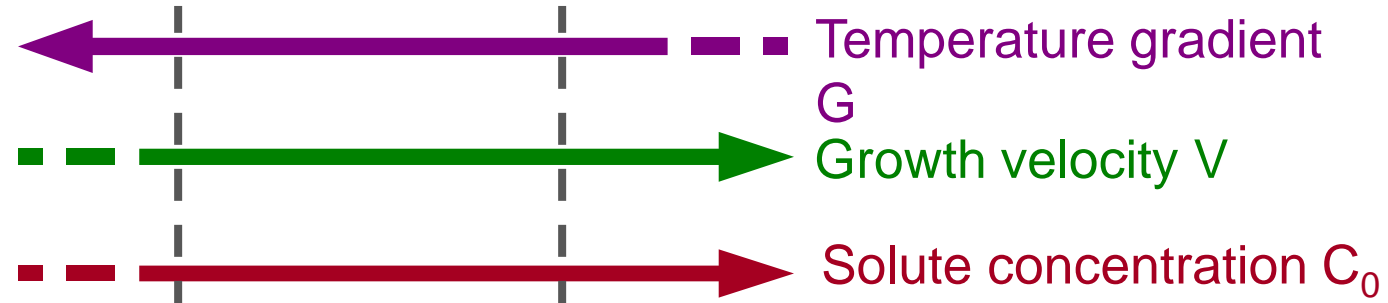
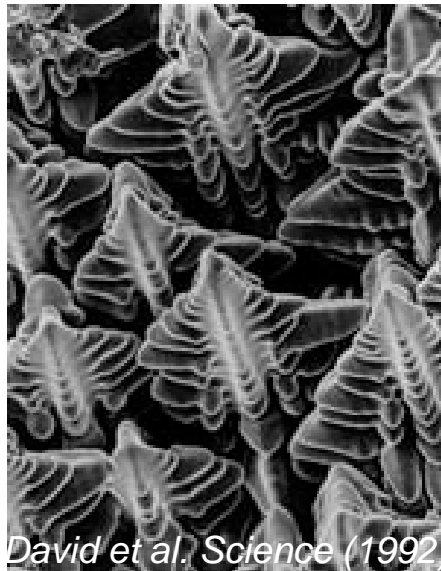
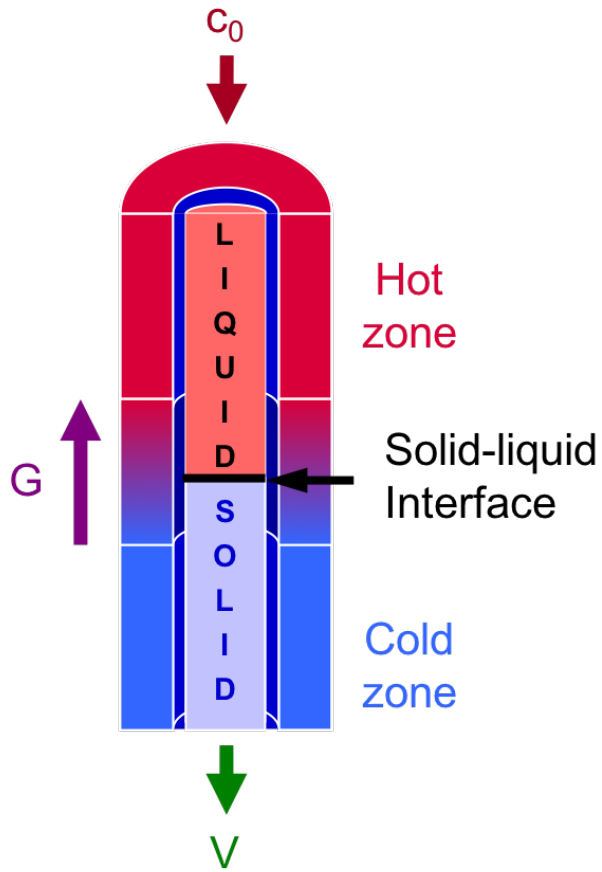

Losert, Shi, and Cummins (1998)

Constitutional supercooling $V > \frac{kDG}{mC_0(1-k)}$



Microgravity experiments – diffusive regime

Gravity-induced convection

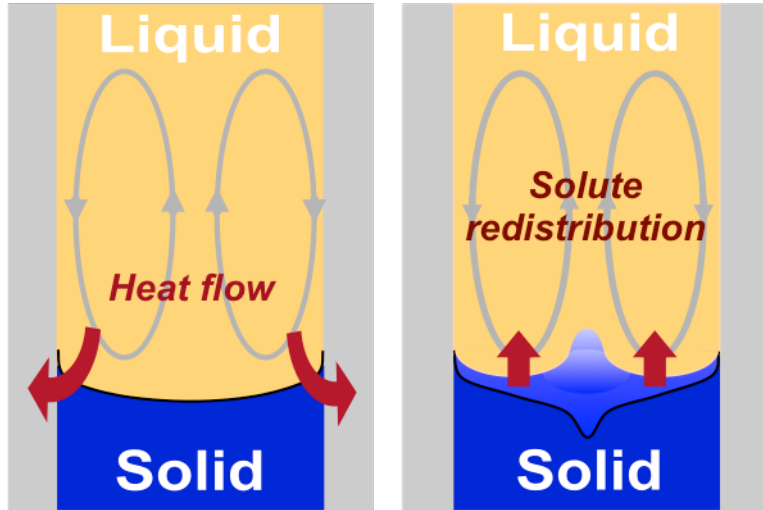

Microgravity experiment

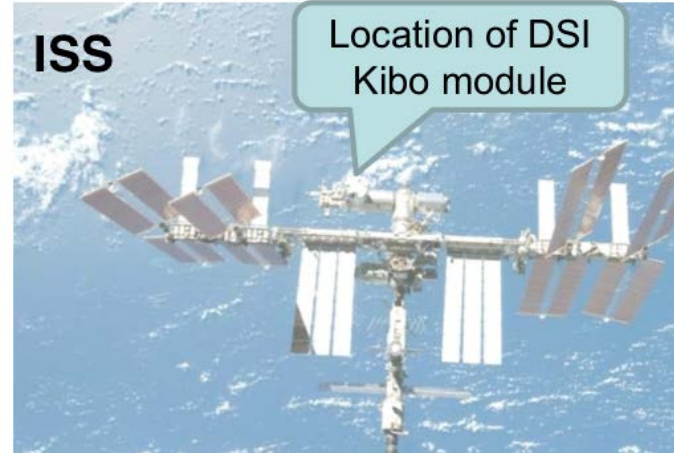

Two campaigns:

- Microgravity experiments from 2009-2011 dedicated to cellular regime.
- Microgravity experiments from 2017-2018 dedicated to dendritic regime.

Microstructure heterogeneities

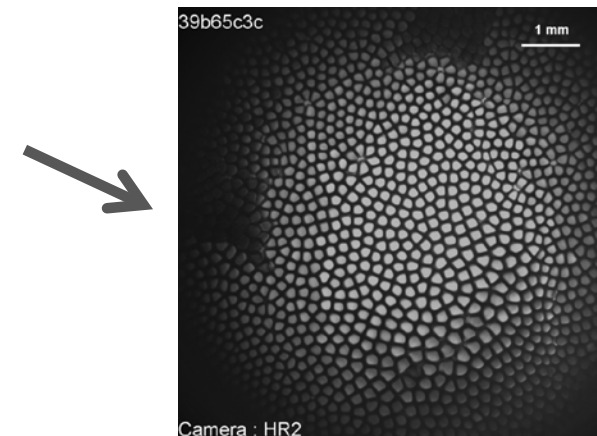
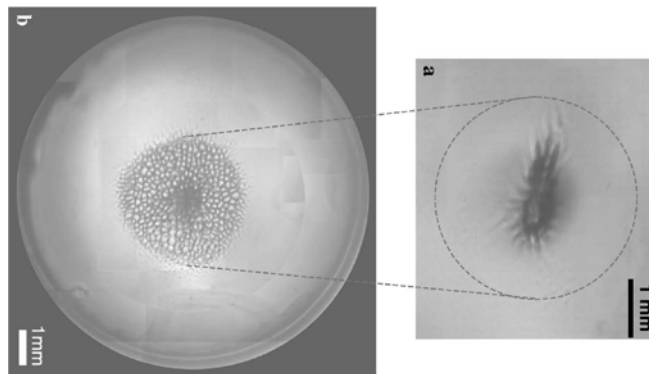

Polycrystalline solidification

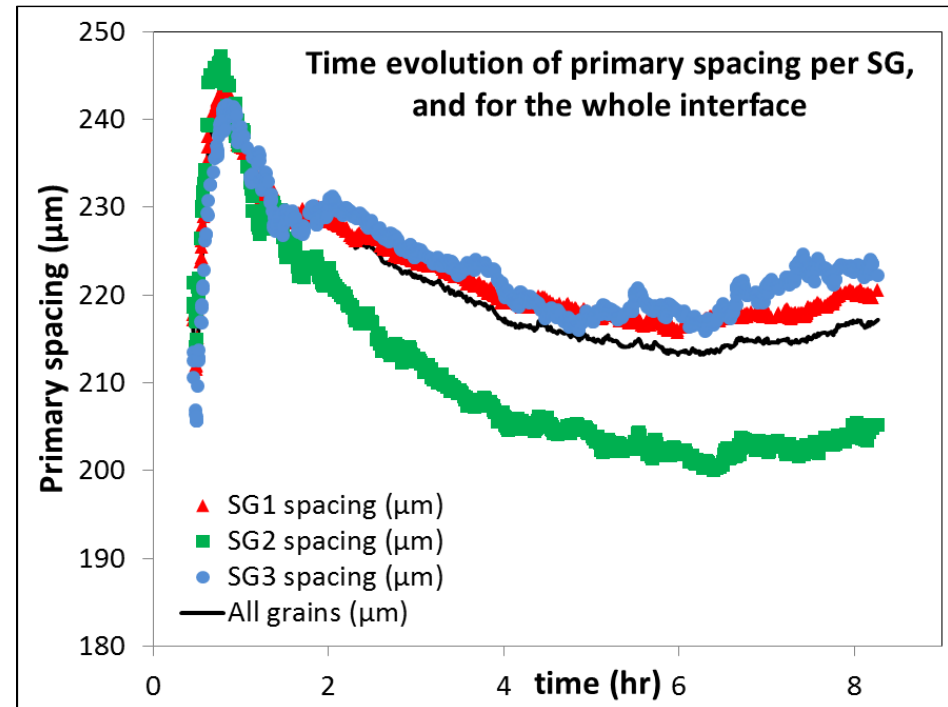
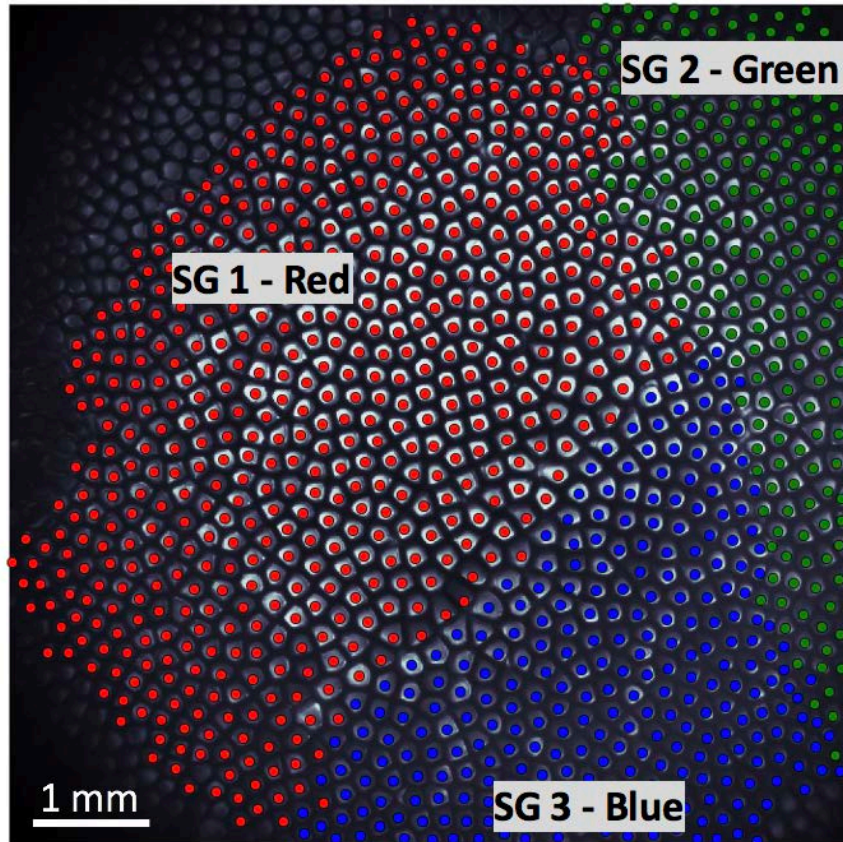

- Noticeable primary spacing evolution depending on sub-grain.
- Cannot be attributed to the misorientation ($1.4^\circ < \theta_g < 1.9^\circ$)

SCN-0.24wt% Camphor, $G = 19 \text{ K/cm}$, $V = 2 \mu\text{m/s}$

Effects of sub-grain boundaries

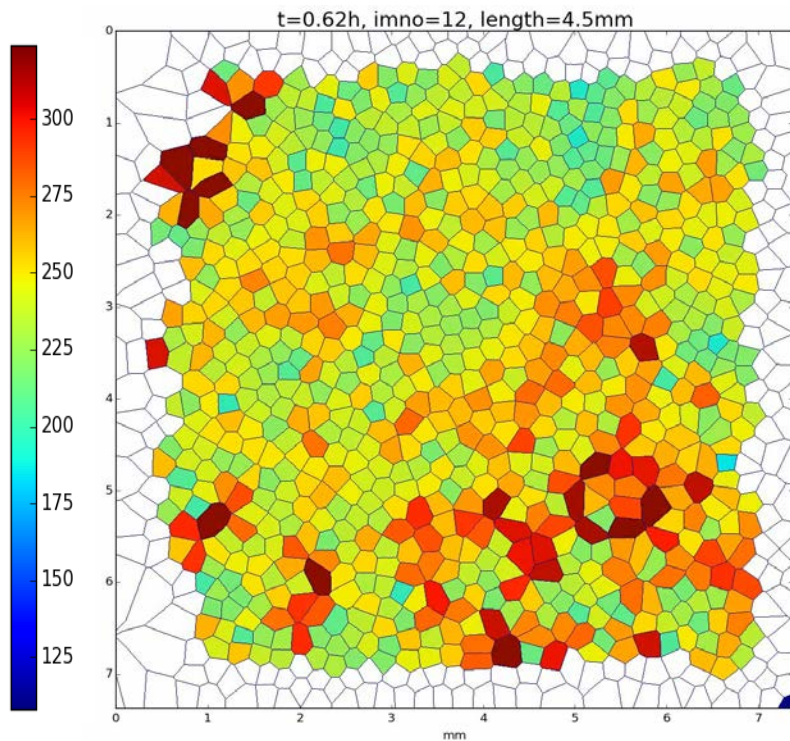

- Initially: large spacing with homogeneous distribution.
- With time: global decrease of spacing except at a divergent sub-grain boundary.

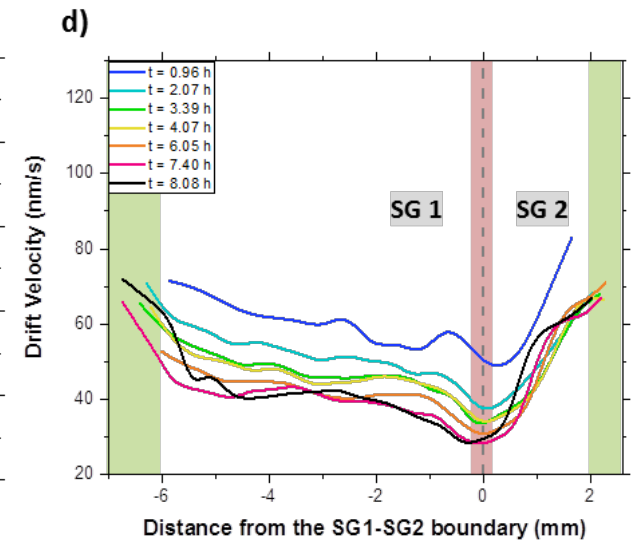
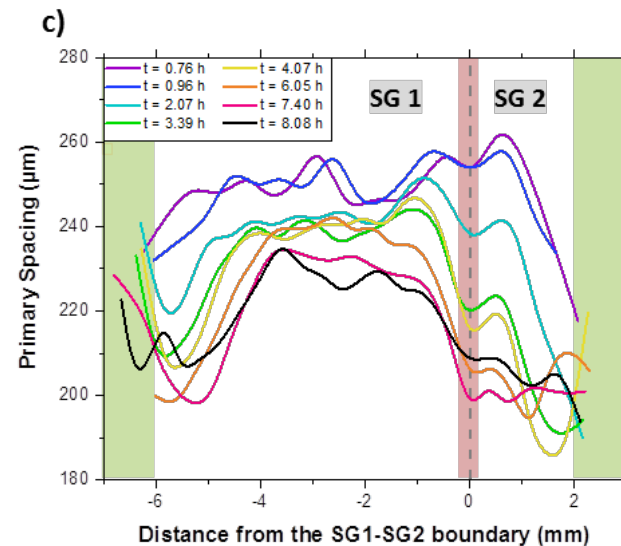
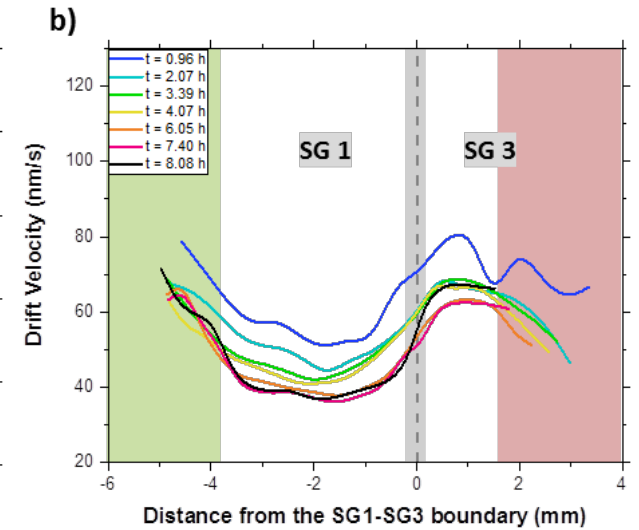
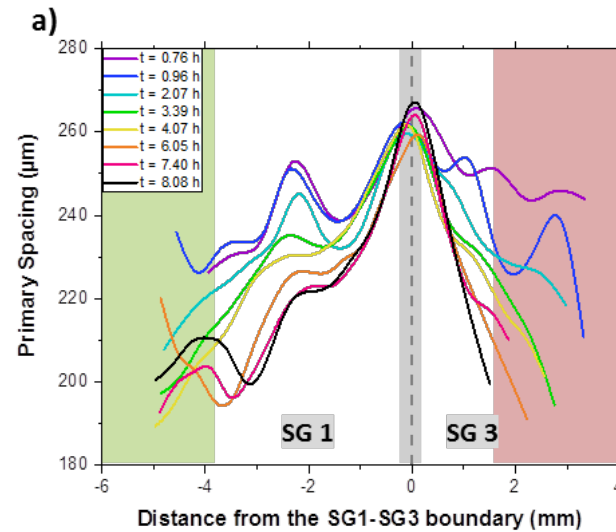

Phase-field simulation

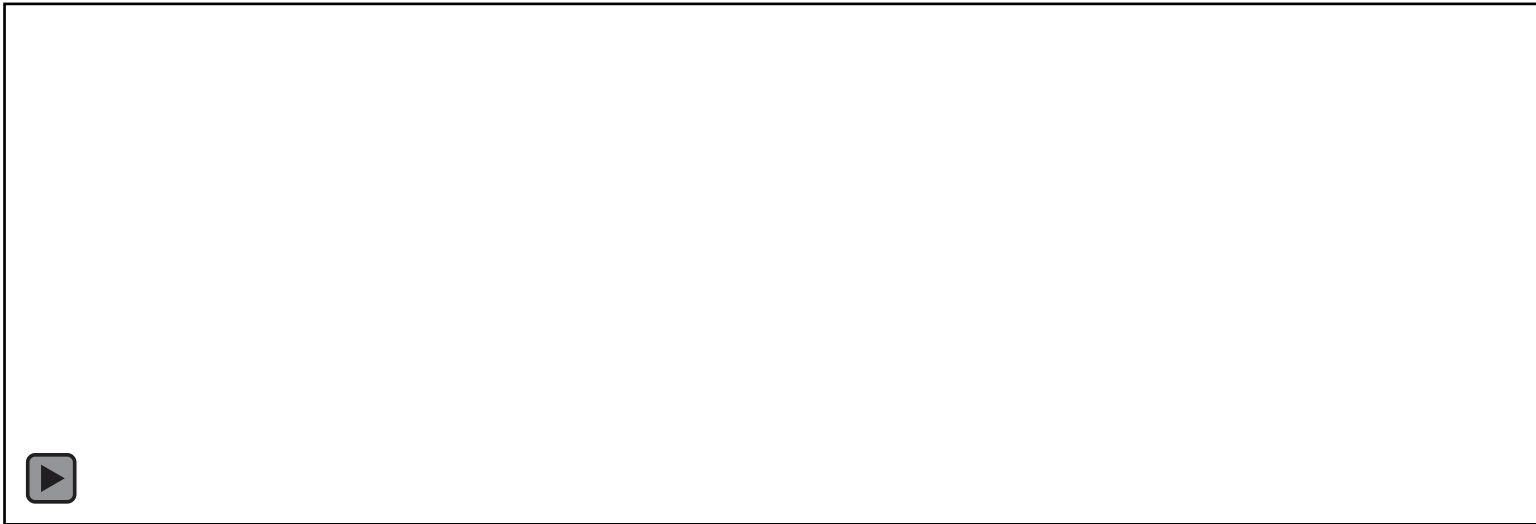

60 μm

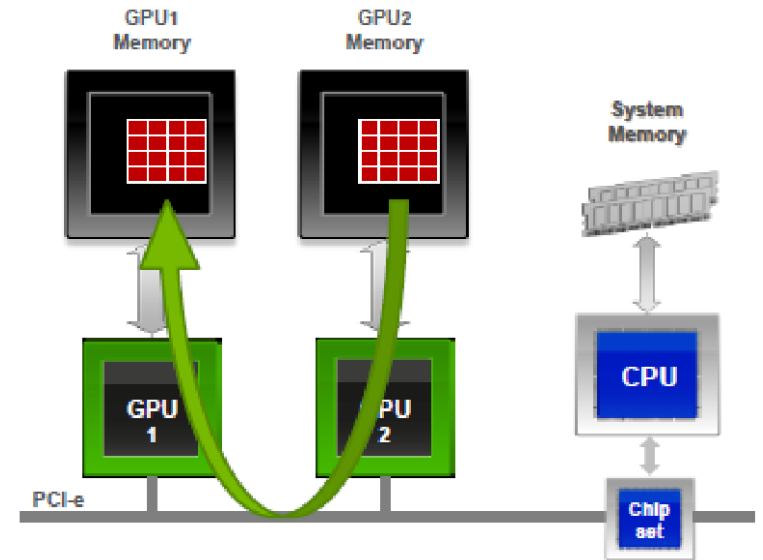
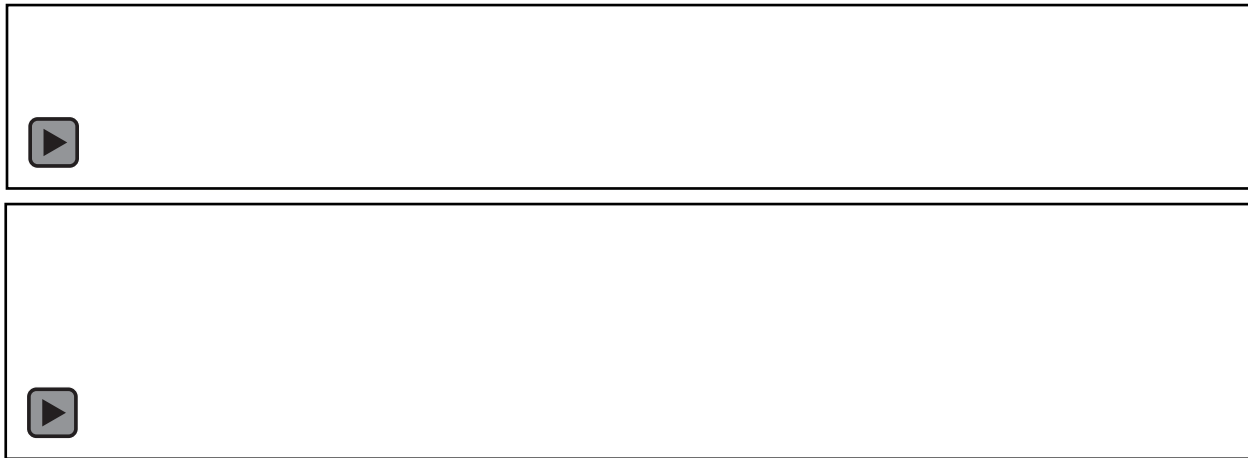
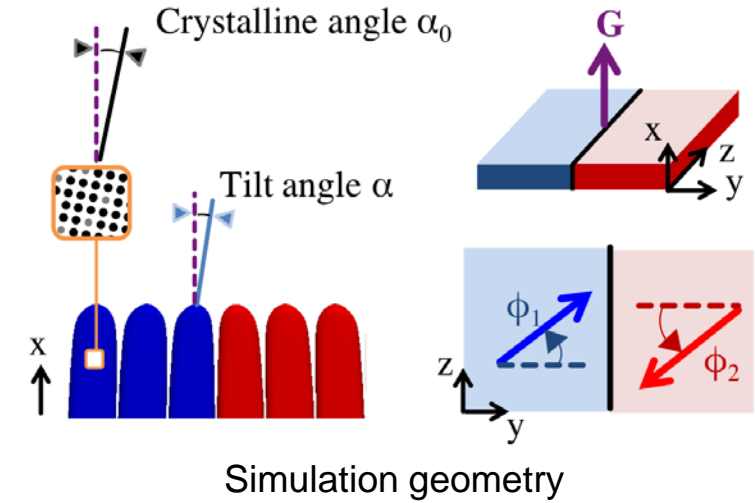

Simulation of SCN-0.24wt% Camphor, $G = 19 \text{ K/cm}$, $V = 2 \mu\text{m/s}$ over 4 hours

Multi-GPU intra-node communication



Divergent sub-grain boundary

Regular hexagonal array

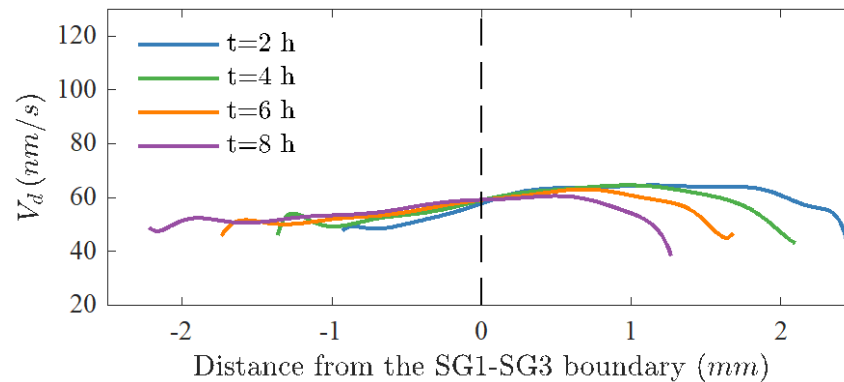
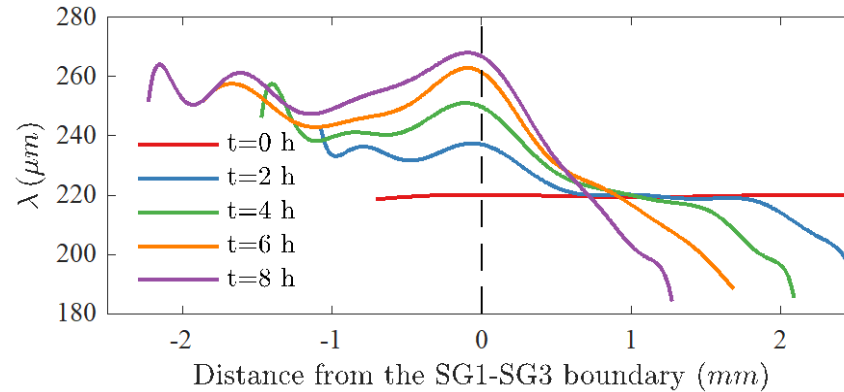
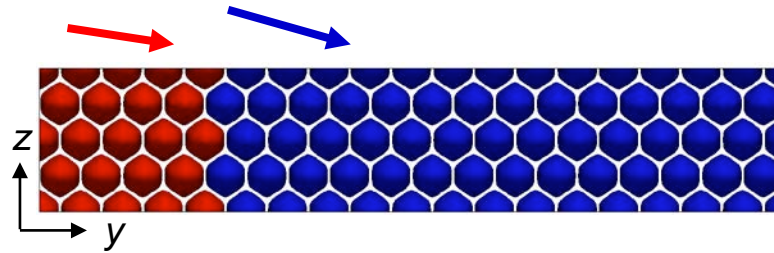

Irregular hexagonal array

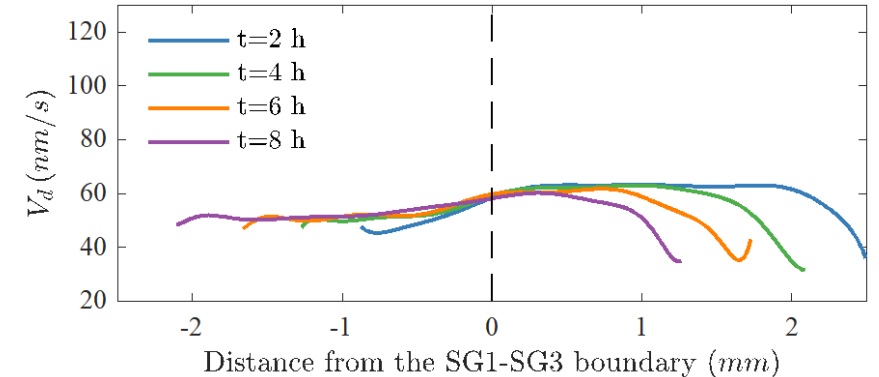
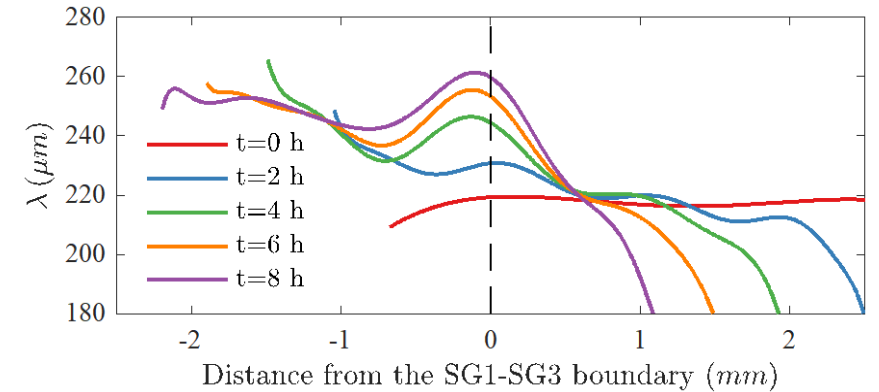
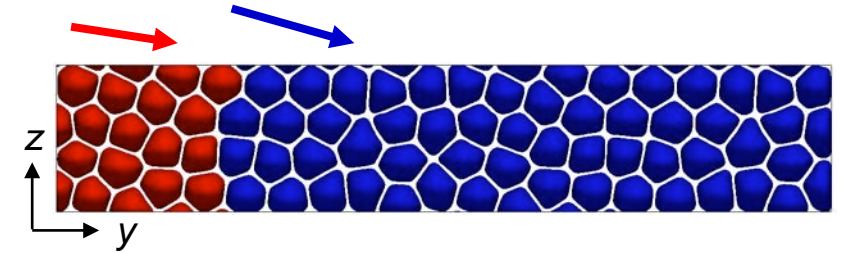

- Peak of primary spacing at the divergent sub-grain boundary (*same as experiments*).
- A plateau with the increasing spacing (*different from experiments*).
- A source on the left that produces larger cells.

Effect of a source

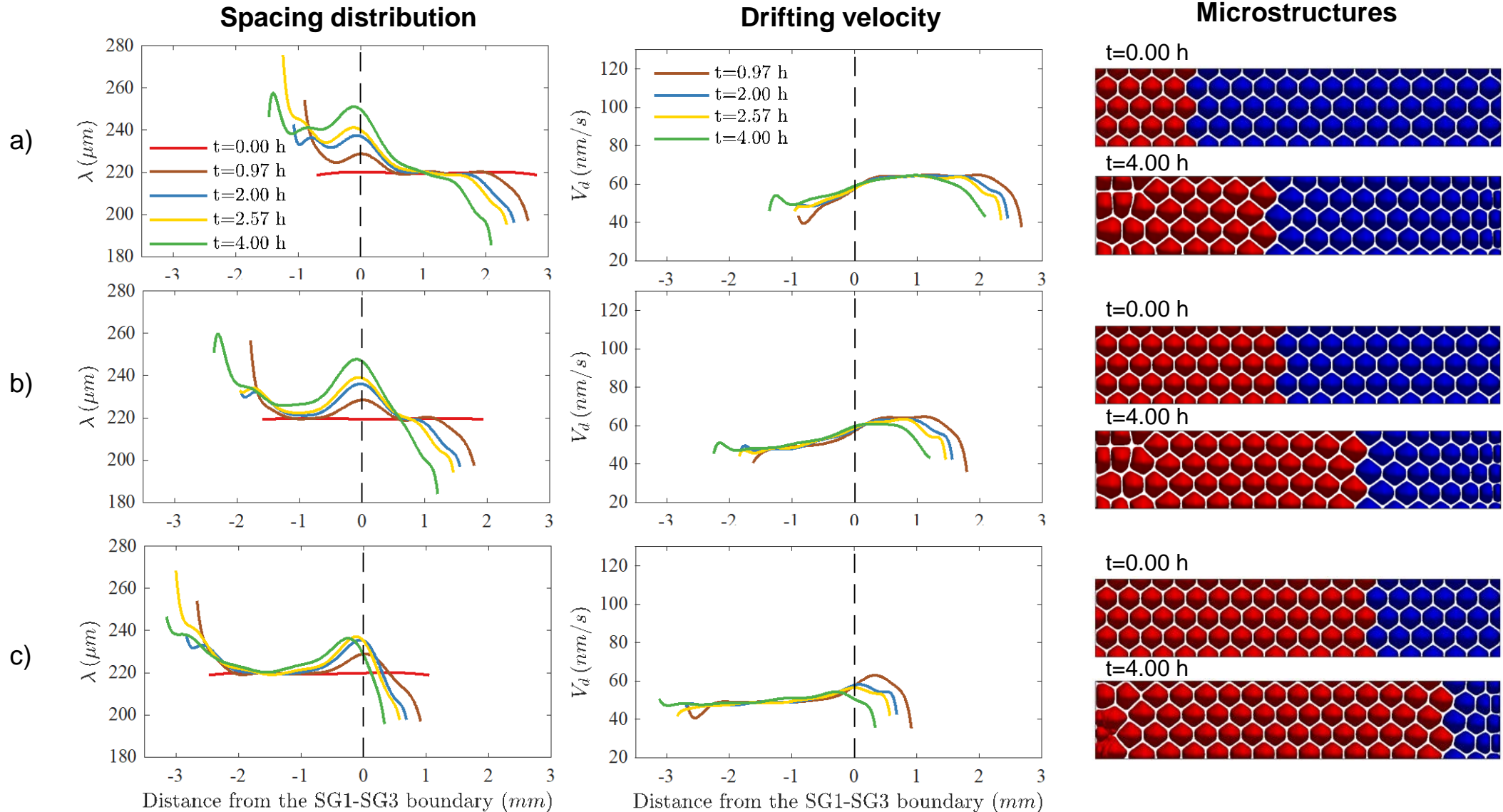

Master curve

- The ratio θ_g/θ_0 between the cell-tilt angle and the misorientation angle is a function of the Péclet number Pe (**master curve**).
- The master curve is independent of the misorientation angle θ_0 .
- The master can be fitted by a phenomenological function with constants f and g .

$$\frac{\theta_g}{\theta_0} \equiv F(Pe) = 1 - \frac{1}{1 + fPe^g}$$

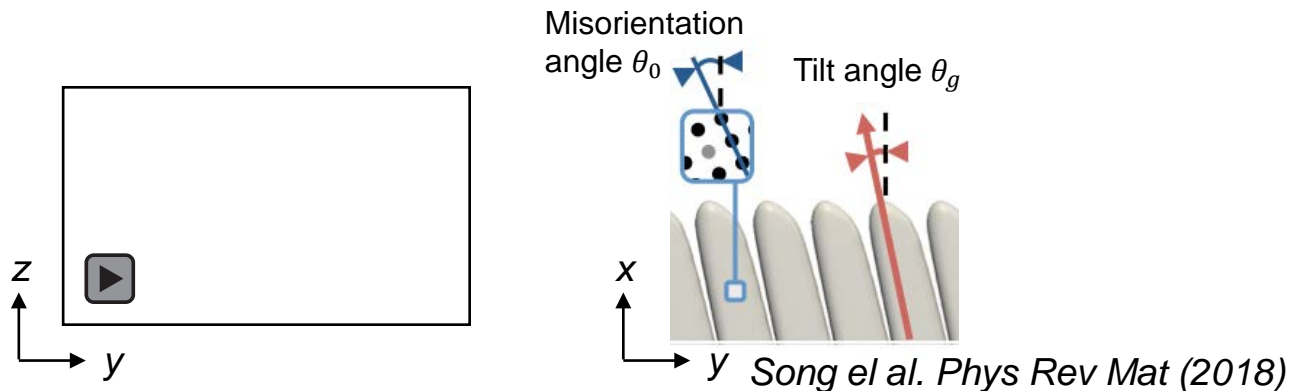
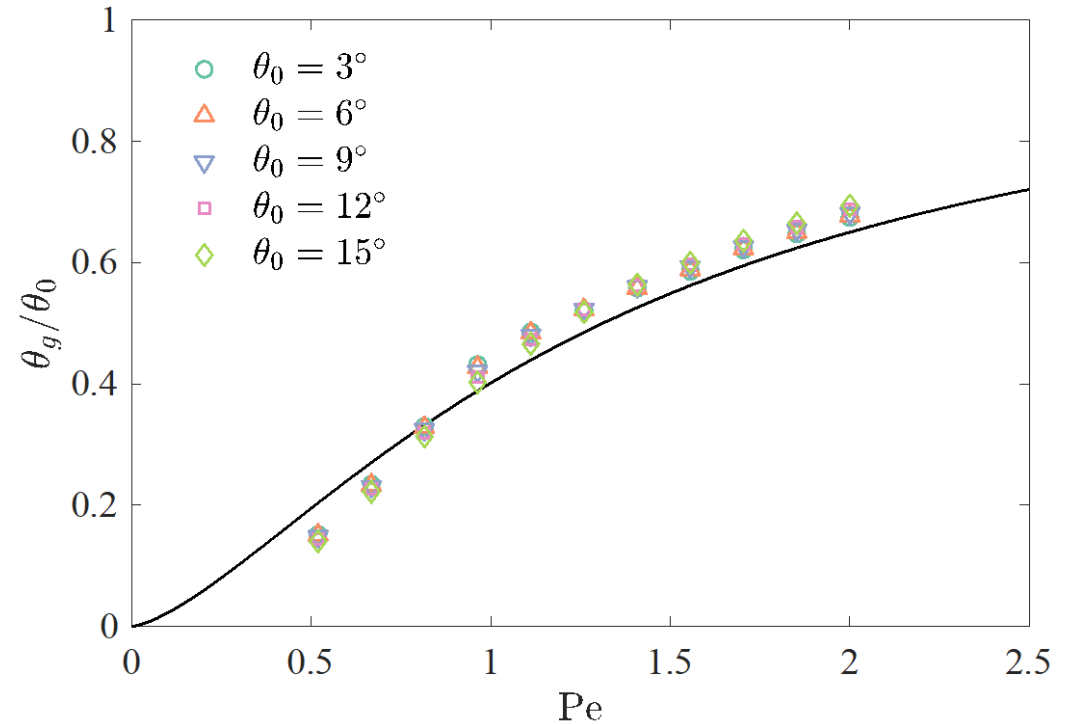

Deschamps, Georgelin and Pocheau, PRE (2008)

Effect of a divergent sub-grain boundary

- The divergent sub-grain boundary can damp the drifting velocities of nearby cells in SG 3 (blue), which have large Pe and are placed below the master curve.
- The divergent sub-grain boundary can boost the drifting velocities of nearby cells in SG 1 (red), which have large Pe and are placed above the master curve.
- The phase diffusion generically relaxes spatially modulated nonequilibrium patterns towards a spatially uniform spacing:

$$\frac{\partial \lambda}{\partial t} = D_\lambda \frac{\partial^2 \lambda}{\partial y^2}$$

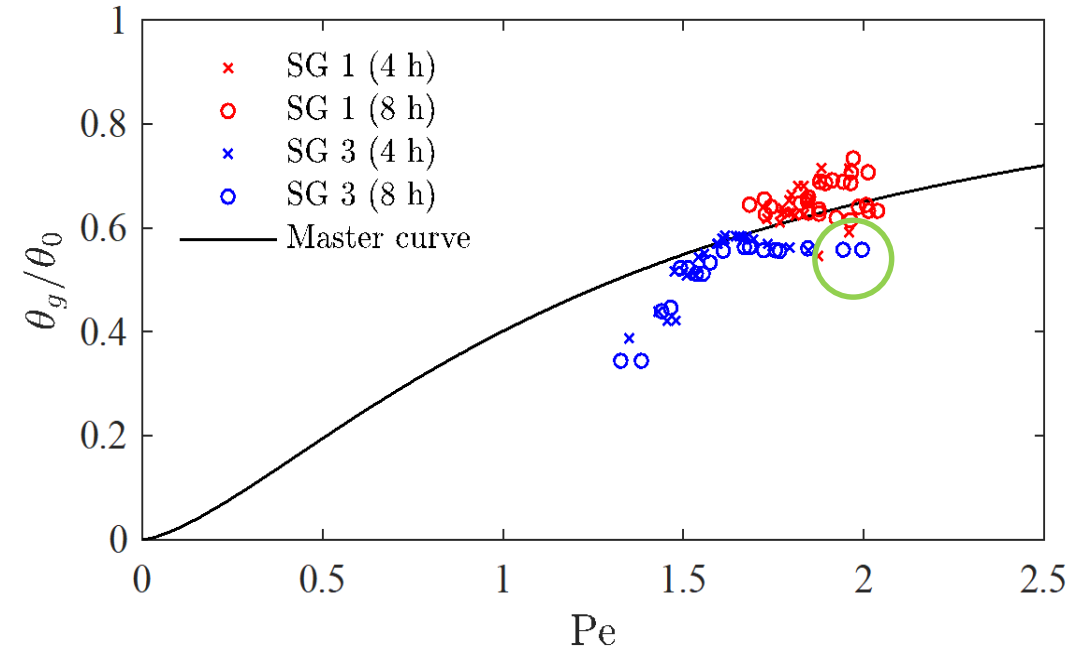
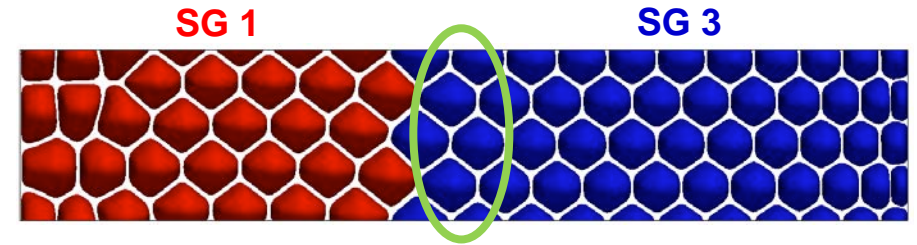

Effect of a convergent sub-grain boundary

- The primary spacing decreases about 60 μm at a convergent sub-grain boundary in simulation, whereas 30 μm in experiments.
- Different stable spacing ranges.
- Different types of grain competition, elimination or invasion.

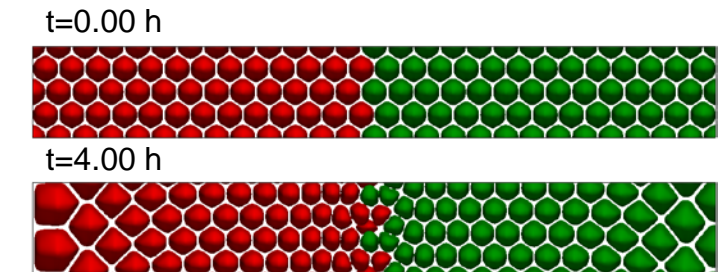
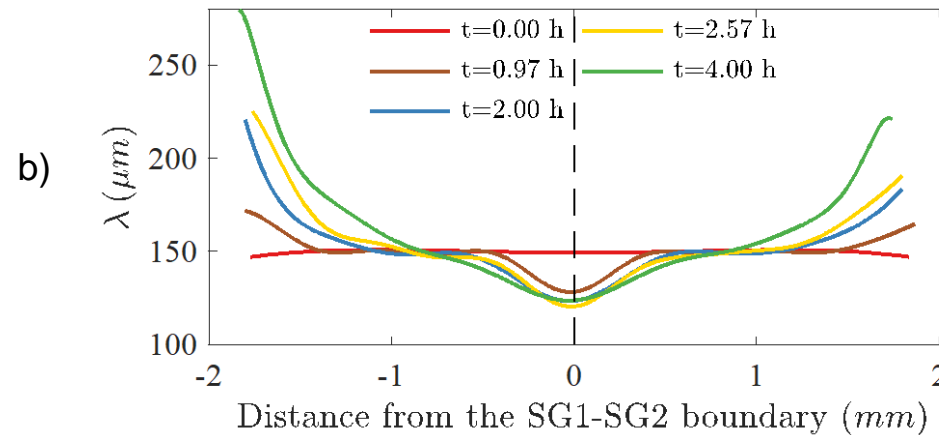
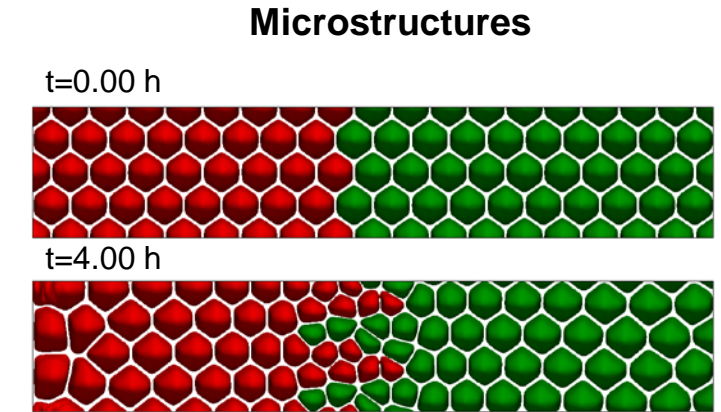
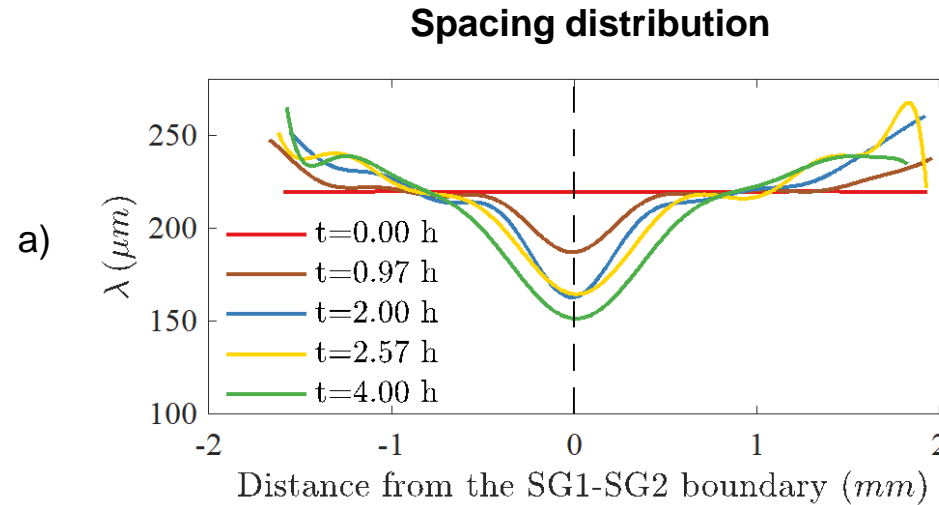

DSI-R: dedicated to the dendritic regime

- Increase the concentration from SCN-0.24wt% Camphor to **SCN-0.46wt% Camphor**. Dendrites form at lower pulling velocity.
- Study of the formation of well-developed dendritic array structures.

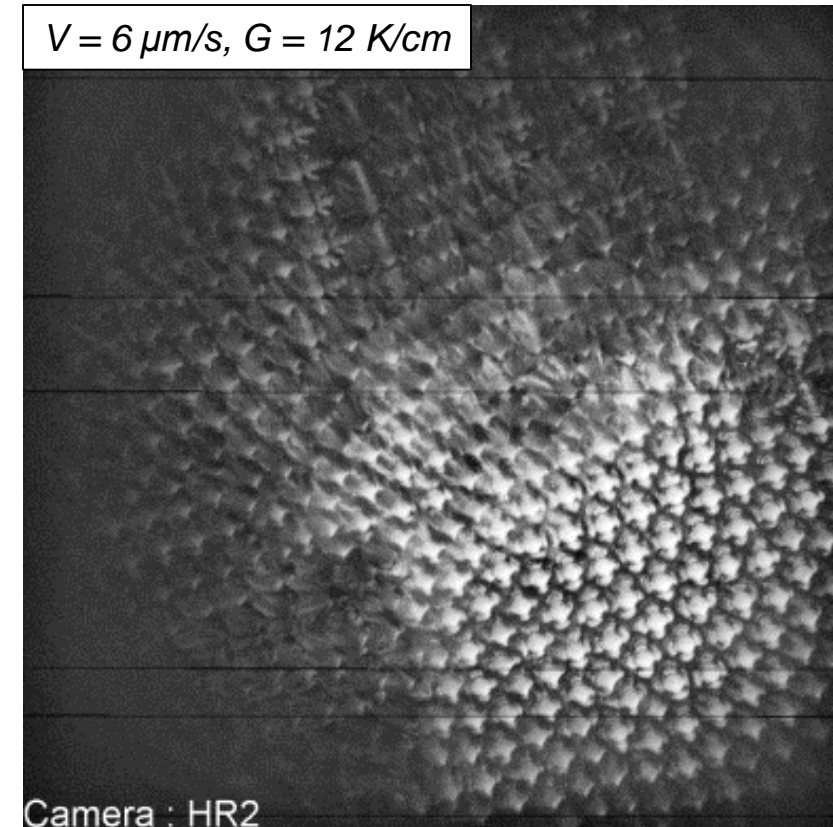
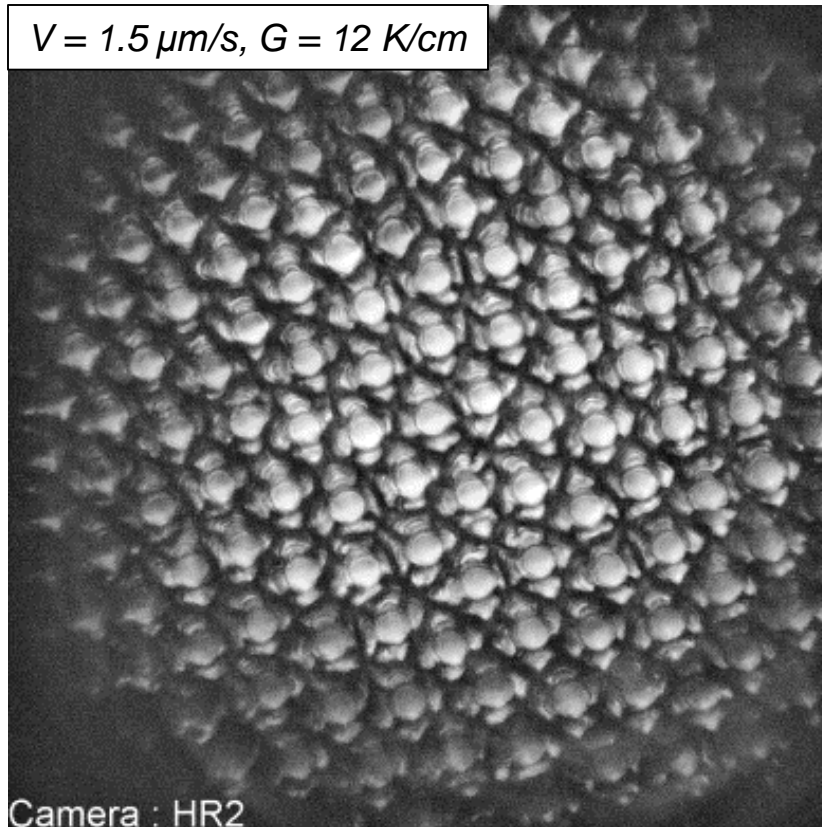

Summary

- Both the divergent and convergent sub-grain boundaries can affect the microstructure evolution during directional solidification of binary alloys, including the primary spacing distribution and the drifting velocity profile.
- Phase-field simulations at experimentally relevant length and time scales show similar results as experiments for a divergent boundary, including the peak and distribution of primary spacing.
- The differences between simulations and experiments are because of a source of cells. In the simulation, a source can produce large cells and lead to an increasing plateau; in the experiment, the small cells are generated near the crucible boarder and leads to a decreasing plateau.
- Near a convergent sub-grain boundary, the differences between simulations and experiments stems from the difference in stable ranges of cell spacings, which leads to different types of grain competition (elimination versus invasion).



Outlook

- Investigate the pulling velocity jump and the history dependence of a dendritic pattern.
- Investigate the thermal diffusivity that varies with the distance from the crucible wall. The spatial dependent thermal diffusivity could affect primary spacing selection and the evolution of an interface curvature in the experiments.
- Experimental observations and phase-field simulations reveal that the selected pattern at a divergent sub-grain boundary is different from the initially selected pattern near the center region of the crucible. The pattern adjustment could come from the drifting dynamics of misoriented grains.

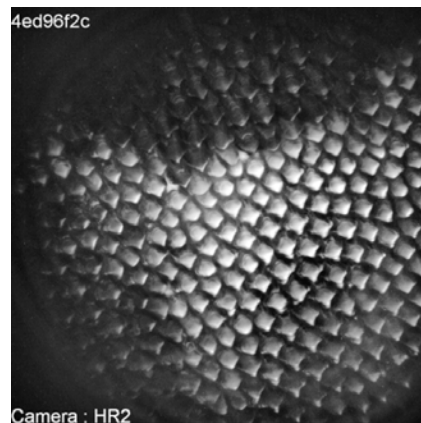

SCN-0.46wt% Camphor,
 $G = 12 \text{ K/cm}, V = 2 \mu\text{m/s}$

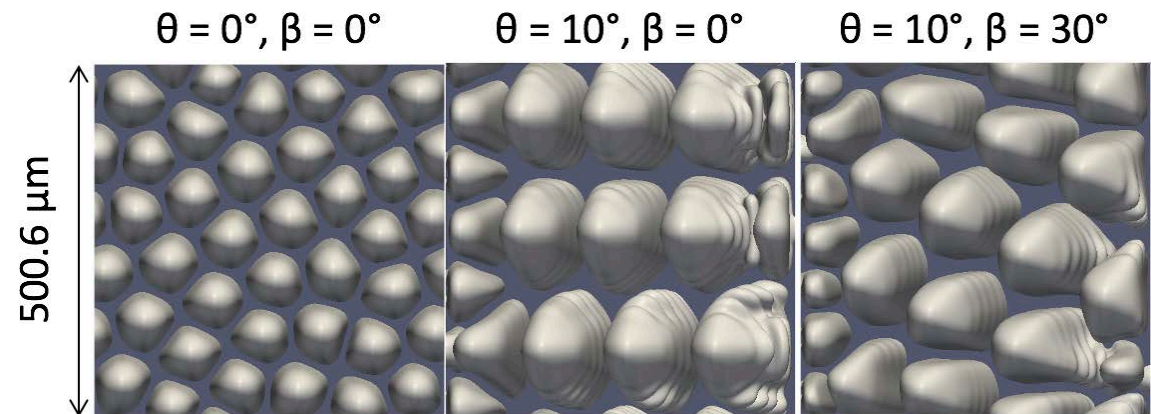

Acknowledgement

Kaihua Ji, Y. Song*, A. Karma
Northeastern University



F.L. Mota, J. Pereda,
N. Bergeon



Aix-Marseillé Université

T. Lyons, R. Trivedi
Iowa state University



L.L. Strutzenberg

Marshall Space Flight Center



Marshall Space
Flight Center

This research is supported by **NASA** through awards 80NSSC19K0135 and NNX16AL77G and by **CNES** through the MISOL3D project (Microstructures de SOLidification 3D).

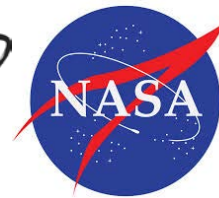

*Current address: Oak Ridge National Laboratory



Thank you
for your attention

