

TECHNICAL NOTE

D-1504

A REPORT ON THE RESEARCH AND TECHNOLOGICAL PROBLEMS
OF MANNED ROTATING SPACECRAFT

By Langley Research Center Staff

Langley Research Center
Langley Station, Hampton, Va.

NATIONAL AERONAUTICS AND SPACE ADMINISTRATION
WASHINGTON

August 1962

1. The first part of the document discusses the importance of maintaining accurate records of all transactions and activities. It emphasizes that this is crucial for ensuring transparency and accountability in the organization's operations.

2. The second part of the document outlines the various methods and tools used to collect and analyze data. It highlights the need for consistent and reliable data collection processes to support effective decision-making.

3. The third part of the document focuses on the role of technology in data management and analysis. It discusses how modern software solutions can streamline data collection, storage, and reporting, thereby improving efficiency and accuracy.

4. The fourth part of the document addresses the challenges associated with data management, such as data quality, security, and privacy. It provides strategies to mitigate these risks and ensure that data is used responsibly and ethically.

5. The fifth part of the document concludes by summarizing the key findings and recommendations. It stresses the importance of ongoing monitoring and evaluation to ensure that data management practices remain effective and up-to-date.

6. The sixth part of the document provides a detailed overview of the data collection process, including the identification of data sources, the design of data collection instruments, and the implementation of data collection procedures.

7. The seventh part of the document discusses the various methods used for data analysis, such as descriptive statistics, inferential statistics, and qualitative analysis. It explains how these methods are applied to interpret the collected data and draw meaningful conclusions.

8. The eighth part of the document focuses on the presentation of data analysis results. It discusses the importance of using clear and concise visualizations, such as charts and graphs, to communicate the findings effectively to stakeholders.

9. The ninth part of the document addresses the ethical considerations surrounding data management and analysis. It emphasizes the need to protect individual privacy and ensure that data is used only for the intended purposes.

10. The tenth part of the document provides a final summary and concludes the report. It reiterates the key points discussed throughout the document and offers final thoughts on the importance of data management in organizational success.

11. The eleventh part of the document discusses the future directions of data management research and practice. It identifies emerging trends and technologies that are likely to shape the field in the coming years.

12. The twelfth part of the document provides a detailed overview of the data analysis process, including the selection of appropriate statistical tests, the interpretation of test results, and the communication of findings to the relevant stakeholders.

13. The thirteenth part of the document focuses on the role of data in strategic decision-making. It discusses how data-driven insights can inform the development of organizational strategy and improve overall performance.

14. The fourteenth part of the document addresses the challenges of data integration and interoperability. It discusses the importance of ensuring that data from different systems and sources can be combined and analyzed effectively.

15. The fifteenth part of the document provides a detailed overview of the data management process, including the selection of data management tools, the implementation of data management policies, and the ongoing monitoring and evaluation of data management practices.

16. The sixteenth part of the document discusses the importance of data literacy and training. It emphasizes the need for employees to have the skills and knowledge necessary to effectively manage and analyze data.

17. The seventeenth part of the document provides a final summary and concludes the report. It reiterates the key points discussed throughout the document and offers final thoughts on the importance of data management in organizational success.

18. The eighteenth part of the document discusses the future directions of data management research and practice. It identifies emerging trends and technologies that are likely to shape the field in the coming years.

19. The nineteenth part of the document provides a detailed overview of the data analysis process, including the selection of appropriate statistical tests, the interpretation of test results, and the communication of findings to the relevant stakeholders.

20. The twentieth part of the document focuses on the role of data in strategic decision-making. It discusses how data-driven insights can inform the development of organizational strategy and improve overall performance.

21. The twenty-first part of the document addresses the challenges of data integration and interoperability. It discusses the importance of ensuring that data from different systems and sources can be combined and analyzed effectively.

22. The twenty-second part of the document provides a detailed overview of the data management process, including the selection of data management tools, the implementation of data management policies, and the ongoing monitoring and evaluation of data management practices.

23. The twenty-third part of the document discusses the importance of data literacy and training. It emphasizes the need for employees to have the skills and knowledge necessary to effectively manage and analyze data.

24. The twenty-fourth part of the document provides a final summary and concludes the report. It reiterates the key points discussed throughout the document and offers final thoughts on the importance of data management in organizational success.

25. The twenty-fifth part of the document discusses the future directions of data management research and practice. It identifies emerging trends and technologies that are likely to shape the field in the coming years.

26. The twenty-sixth part of the document provides a detailed overview of the data analysis process, including the selection of appropriate statistical tests, the interpretation of test results, and the communication of findings to the relevant stakeholders.

27. The twenty-seventh part of the document focuses on the role of data in strategic decision-making. It discusses how data-driven insights can inform the development of organizational strategy and improve overall performance.

28. The twenty-eighth part of the document addresses the challenges of data integration and interoperability. It discusses the importance of ensuring that data from different systems and sources can be combined and analyzed effectively.

29. The twenty-ninth part of the document provides a detailed overview of the data management process, including the selection of data management tools, the implementation of data management policies, and the ongoing monitoring and evaluation of data management practices.

30. The thirtieth part of the document discusses the importance of data literacy and training. It emphasizes the need for employees to have the skills and knowledge necessary to effectively manage and analyze data.

31. The thirty-first part of the document provides a final summary and concludes the report. It reiterates the key points discussed throughout the document and offers final thoughts on the importance of data management in organizational success.

32. The thirty-second part of the document discusses the future directions of data management research and practice. It identifies emerging trends and technologies that are likely to shape the field in the coming years.

33. The thirty-third part of the document provides a detailed overview of the data analysis process, including the selection of appropriate statistical tests, the interpretation of test results, and the communication of findings to the relevant stakeholders.

34. The thirty-fourth part of the document focuses on the role of data in strategic decision-making. It discusses how data-driven insights can inform the development of organizational strategy and improve overall performance.

35. The thirty-fifth part of the document addresses the challenges of data integration and interoperability. It discusses the importance of ensuring that data from different systems and sources can be combined and analyzed effectively.

36. The thirty-sixth part of the document provides a detailed overview of the data management process, including the selection of data management tools, the implementation of data management policies, and the ongoing monitoring and evaluation of data management practices.

37. The thirty-seventh part of the document discusses the importance of data literacy and training. It emphasizes the need for employees to have the skills and knowledge necessary to effectively manage and analyze data.

38. The thirty-eighth part of the document provides a final summary and concludes the report. It reiterates the key points discussed throughout the document and offers final thoughts on the importance of data management in organizational success.

39. The thirty-ninth part of the document discusses the future directions of data management research and practice. It identifies emerging trends and technologies that are likely to shape the field in the coming years.

40. The fortieth part of the document provides a detailed overview of the data analysis process, including the selection of appropriate statistical tests, the interpretation of test results, and the communication of findings to the relevant stakeholders.

41. The forty-first part of the document focuses on the role of data in strategic decision-making. It discusses how data-driven insights can inform the development of organizational strategy and improve overall performance.

42. The forty-second part of the document addresses the challenges of data integration and interoperability. It discusses the importance of ensuring that data from different systems and sources can be combined and analyzed effectively.

43. The forty-third part of the document provides a detailed overview of the data management process, including the selection of data management tools, the implementation of data management policies, and the ongoing monitoring and evaluation of data management practices.

NATIONAL AERONAUTICS AND SPACE ADMINISTRATION

TECHNICAL NOTE D-1504

A REPORT ON THE RESEARCH AND TECHNOLOGICAL PROBLEMS
OF MANNED ROTATING SPACECRAFT

By Langley Research Center Staff

L
3
1
8
6

FOREWORD

A general research program to explore the technical problems of rotating manned spacecraft has been underway at the Langley Research Center for some time. A report summarizing progress on some of the more significant aspects of the work accomplished thus far was recently presented to a group of NASA personnel sharing interest in this work at a symposium held at the Langley Research Center from July 31 to August 1, 1962. The collection of papers contained in this report is a summary of the material presented. It is published in this form for the convenience of other organizations and individuals who may be engaged in similar studies.

It is emphasized that the investigations reported herein are exploratory in nature. There is no approved NASA program for the construction and operation of any such spacecraft.



CONTENTS

	Page
1. SPACE-STATION OBJECTIVES AND RESEARCH GUIDELINES . . . By P. R. Hill and Emanuel Schnitzer	1
2. SPACE-STATION RESEARCH CONFIGURATIONS . . . By Rene A. Berglund	9
3. TEMPERATURE BALANCE OF MANNED SPACE STATIONS . . . By Lenwood G. Clark	21
4. STRUCTURAL REQUIREMENTS OF LARGE MANNED SPACE STATIONS . . . By George W. Zender and John R. Davidson	33
5. MATERIALS AND FABRICATION TECHNIQUES FOR MANNED SPACE STATIONS . . . By Robert S. Osborne and George P. Goodman	45
6. SPACE-STATION POWER SYSTEMS . . . By John R. Dawson and Atwood R. Heath, Jr.	59
7. SPACE-STATION DYNAMICS AND CONTROL . . . By Peter R. Kurzhals, James J. Adams, and Ward F. Hodge . . .	71
8. EFFECTS OF ROTATION ON THE ABILITY OF SUBJECTS TO PERFORM SIMPLE TASKS . . . By Ralph W. Stone, Jr., and William Letko	85
9. SOME CONSIDERATIONS OF THE OPERATIONAL REQUIREMENTS FOR A MANNED SPACE STATION . . . By Roy F. Brissenden	95
10. LIFE SUPPORT RESEARCH FOR MANNED SPACE STATIONS . . . By Dan C. Popma, Charles H. Wilson, and Franklin W. Booth	107
11. STRUCTURAL DYNAMIC ASPECTS OF LAUNCH-VEHICLE—SPACE-STATION COMPATIBILITY . . . By Harry L. Runyan and George W. Brooks	121
12. CREW PERFORMANCE ON A LUNAR-MISSION SIMULATION . . . By Joseph S. Algranti, Donald L. Mallick, and Howard G. Hatch, Jr.	135

L
3
1
3
5

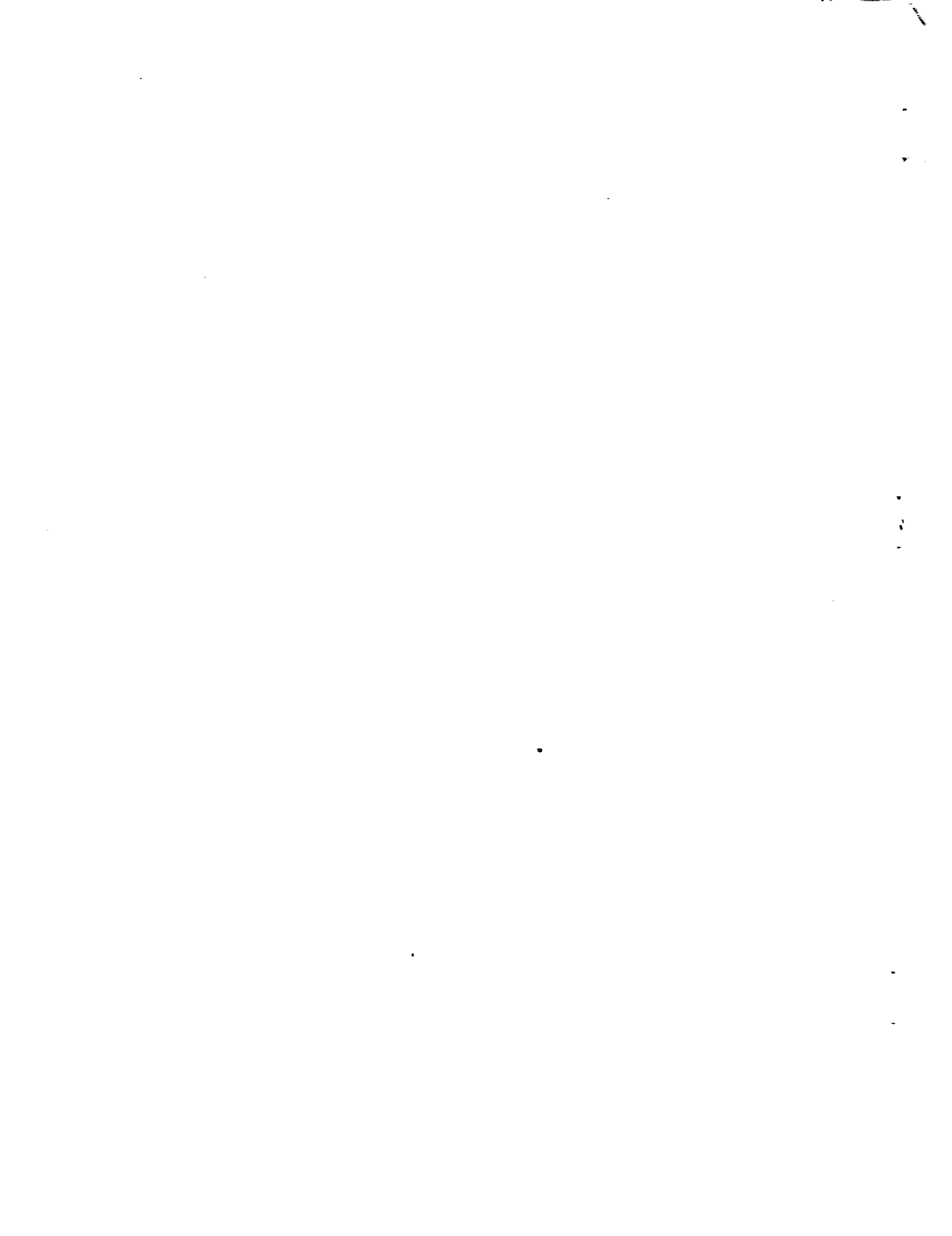

1. SPACE-STATION OBJECTIVES AND RESEARCH GUIDELINES

By P. R. Hill and Emanuel Schnitzer

SUMMARY

L
3
1
8
6
A large manned orbiting space station may have many uses or objectives. Among these are long-term experiments at zero gravity and various gravity levels as well as the utilization of various space systems for learning how to live in space for extended periods. Other uses include engineering applications such as communications and earth observations, orbital launch platform experiments, and, finally, scientific experiments.

In order to formulate the space-station research program at the Langley Research Center, the following space-station guidelines have been adopted:

- (1) Atmospheric composition and temperature closely controlled
- (2) A range-of-gravity capability (0 to 1 g)
- (3) Launch and deployment from single launch vehicle
- (4) Natural and artificial stability
- (5) Rendezvous-dock-abort capability
- (6) Onboard power generation
- (7) External environment compatibility
- (8) Lifetime from 1 to 5 years.

These guidelines have established the basis for the space-station research programs reviewed in this and subsequent papers.

INTRODUCTION

The opportunities for research in space provided by a manned space station have long been recognized. Some of the objectives to be attained and the guidelines for this research are presented in this paper.

OBJECTIVES

The versatility of a large manned orbiting vehicle allows a variety of experimental objectives to be accomplished. Some of these objectives

are as follows:

- (1) Learning to live in space
 - (a) Artificial-gravity experiments
 - (b) Zero-gravity experiments
 - (c) Systems research and development
- (2) Applications research
 - (a) Communications experiments
 - (b) Earth observation
- (3) Launch platform experiments
- (4) Scientific research

Before man can undertake long duration missions such as the exploration of the planets, he must learn the technologies that will permit him to live and work in space for extended periods. Hence, the first objective is learning to live in space. The biggest difference between living on earth and living in space is the apparent lack of gravity in space. Artificial gravity brings the astronaut, and all equipment, closer to an earth-type environment. One of the prime objectives of a space station then is the carrying out of artificial-gravity experiments at various gravity levels. These would be obtained with different rotational speeds to determine optimums for living in space. Experiments at zero gravity have just begun with Project Mercury and will be continued with the Gemini and Apollo programs up to periods of a few weeks. Longer range zero-gravity experiments constitute another space-station objective. Such experiments would determine whether long-term physiological changes occurred and would include an evaluation of the effectiveness of exercise and other aids in promoting well-being at zero gravity. Living in space also means that research and development of many systems, such as closed ecological systems, rendezvous systems, and temperature-control systems, must be carried out under space conditions.

There is currently great interest in what is classified here as applications research. For example, as a communication experiment the space station might be used as a communications link with distant space vehicles employing EHF (extreme high frequency), which will not readily pass through the earth's atmosphere, in order to obtain a narrow beam width and great distance capability. Another example is earth observation. With a manned system the percentage of small-area observation to large-area scan would be favorably increased because of the human capabilities of selection and discrimination. For example, data pictures of the weather could be obtained by a man operating the project from the space station; thus, relatively few pictures would give the required story with minimum delay.

The next objective is launch platform experiments. The space station with its crew of trained astronauts and technicians should be a suitable facility for learning some of the fundamental operations necessary for launching space missions from orbit. The new technologies required for rendezvous, assembly, orbital countdown, replacement of defective parts, and orbital launch can be determined.

The last objective is scientific research. The scientific uses for the station are numerous, and will not be discussed. However, two of them are obvious. The continuous monitoring of high-energy radiation for the safety of the crew will result in much detailed information on the variations or sporadic nature of this radiation below the Van Allen belts. Also, since the space station will be one of the largest objects in the sky, much practical, long-term information on meteoroid damage will be obtained.

GUIDELINES

In order to plan and guide our space-station research programs Langley deemed it necessary to study space-station configurations and to carry out the conceptual design of several space stations in order to uncover the problem areas inherent in such vehicles. These studies have been in progress for over 2 years and the work being reported herein includes both in-house and contractual efforts. To make meaningful conceptual designs, it was beneficial to set up a number of rational space-station requirements or guidelines based on the objective purposes of a space station and its natural environment. These guidelines have also served to direct and orient the research program that will be reviewed and are as follows:

- (1) Human factors compatibility
 - (a) Shirt-sleeve environment
 - (b) Regenerative life support
- (2) Range-of-gravity capability (0 to 1 g) and large rotational radius
- (3) Unitized structure
 - (a) Launch-vehicle—payload compatibility
 - (b) Automatic deployment
- (4) Natural and artificial stability
- (5) Rendezvous-dock-abort capability

- (6) Power generation, variable demand
- (7) External environment compatibility
- (8) Reasonable lifetime

The first guideline is human factors compatibility. A shirt-sleeve environment or shirt-sleeve temperature infers a high degree of temperature stability or a precise method of control. It will be shown in the presentation of thermal problems (paper no. 3) that good wall insulation combined with a radiator heat-rejection system can meet this requirement. Because of a long anticipated lifetime and the great cost of resupply missions, regenerative life support systems are preferred to reduce resupply to a minimum. Langley Research Center has a rather thorough research program underway on life support systems. The status of this research will be given in the paper on life support systems (paper no. 10).

L
3
1
8
6

Second, in order to meet the objective of learning to live in space and to carry out the needed experiments at various gravity levels, a range-of-gravity capability from 0 to 1 g is specified. The use of artificial gravity brings in a number of rotational parameters such as rotational rate and rotational radius that must be considered.

The interrelations between these rotational parameters and the crew are illustrated in figure 1. This figure shows how the size requirement for the station was determined. The ordinate and abscissa of this plot are the logarithms of the rotational radius and angular velocity. Shown in the figure are lines of constant rotational speed and lines of constant fractional gravity, the scale being given at the top of the figure. The main feature of the chart is the shaded area or estimated comfort zone, which is similar to others found in the literature on artificial gravity. Only two comfort zone limits need concern us at present. One is the 20-foot-per-second rotational-speed boundary above which the difference in gravity between walking and standing is less than 10 to 15 percent. Expressed in other terms, above and to the right of this boundary line, the effect of the Coriolis acceleration on the occupants is negligible. The second limit is the boundary shown at 4 rpm, to the right of which, based on centrifuge studies such as those at Pensacola, vestibular disturbances may appear. This boundary results from the very unpleasant sensation that occurs when the head is turned rapidly about an axis perpendicular to the axis of rotation of the station.

Two horizontal dashed lines are shown in figure 1, one for a 50-foot radius which almost misses the comfort zone and one for a 75-foot radius which intersects the comfort zone from 0.17g to 0.4g which would seem practical in that it duplicates lunar "g" at the lower angular velocity and gives a range of gravity in the comfort zone. The conclusion from this chart is that a station having a radius in the general neighborhood of 75 feet is desirable.

Research at Langley on a rotating platform, which will be presented in paper no. 8, shows that the boundary at 4 rpm is not a hard and fast boundary but moves to higher angular velocities with adaptation of the experimental subject. Further information on obtaining the desired range of gravity will be given in paper no. 2.

The third guideline is a unitized structure. By this is meant a structure which can be carried aloft on a single launch vehicle. Because of the large dimensions of the erected station it must be broken into elements which when suitably folded or packaged become a reasonably compact payload. The phrase launch-vehicle—payload compatibility refers not only to the performance requirements but means also that the destabilizing aerodynamic moments must not overpower the control system, that the structural natural frequencies do not couple among themselves or with the pitch frequencies, and that the aerodynamic features of the payload do not create large buffeting forces. These problems will be discussed in relation to one of the space-station conceptual designs in paper no. 11.

Automatic deployment refers to the powered kinematic unfolding of the station to its final erected form. Compared with erection by space tugs this procedure removes the burden of effort from the astronaut and places it on the research laboratory and design engineer. This guideline has been an important factor in shaping our research program. Configuration research and methods of automatic deployment are discussed in paper no. 2.

Natural stability is an important guideline. In case the artificial stabilization fails, it is necessary for the safety of the station crew members that the station have an excellent natural stability so that large oscillations will not build up. These oscillations would make it difficult to approach the station for docking and even dangerous to abandon ship.

It is much easier to understand the dynamics of rotating space stations if one considers the stability criteria outlined in figure 2. The station will be very stable if the moment of inertia about the spin axis is substantially greater than the moment of inertia about the other two axes as in a wheel. The station will still be stable if the moment of inertia about the spin axis is substantially less than about the other two axes as in a spinning shell. Conditions approaching equal inertias as in a sphere should be avoided because this condition results in neutral stability. An even worse condition is that of turning about an axis of intermediate inertia as illustrated in the lower right-hand corner of figure 2. For this condition I_x is greater than I_z and, of course, I_y is smaller. The station will turn only about the Z-axis but with the slightest disturbance will roll with large amplitudes about the Y-axis, in effect turning about two axes at once.

With regard to artificial stability, disturbances of any size infer the need for a damper, for space motions are essentially undamped. Control is also needed for orientation. Research with automatic gyro dampers has been particularly successful and this work is reported in paper no. 7.

The next guideline is rendezvous capability, docking capability, and abort-from-orbit capability. The latter means that there should be room in available ferries to evacuate the entire crew in case of an emergency. This requirement and the ferry capacity and docking facilities available limit the maximum safe crew number. In general, the crew number has been treated as a variable lying between a lower limit for operating the station and an upper value as high as 38 specified for the life-support-system capacity in a feasibility study. A discussion of some of the space-station logistics problems is presented in paper no. 9.

L
3
1
8
6

The station requires onboard power generation with variable demand because of the power variations imposed by a variable workload and variations in crew number. A discussion and comparison of feasible power plants will be given in paper no. 6.

The station must, of course, be compatible with the external environment. The external environment considered is as follows:

- (1) Radiation
 - Thermal
 - Ultraviolet
 - High-energy particle
- (2) Orbit
 - Inclination (28° to 33°)
 - Altitude (approximately 300 nautical miles)
 - Eccentricity (≤ 0.01)
- (3) Vacuum (1×10^{-8} mm Hg)
- (4) Meteoroids

Radiation is the most controlling factor in the external environment. Thermal radiation causes variations in external surface temperatures that will probably lie within the range -50° F to 150° F. The solar ultraviolet radiation is of concern because of its effects on plastic materials and surface finishes. The high-energy particle radiation of concern comes from solar storms and the Van Allen belts.

The approach to the high-energy radiation problem has been to avoid it by an appropriate orbit selection. With a low-orbit inclination of 28° to 33° , the consensus of opinion is that the station would be shielded by the Van Allen belts from all but possibly the giant solar flares which

occur on the average about once in 4 years. The orbiting altitude of approximately 300 nautical miles or less in conjunction with an eccentricity of less than 1 percent is to keep the station below the effects of the Brazilian lows of the inner belt. The pressure at this altitude is about 1×10^{-8} mm Hg. This vacuum, the ultraviolet radiation, and the surface-temperature range of -50° F to 150° F are used as a guide to the materials environmental research which will be presented in the paper on materials and fabrication methods (paper no. 5). The station must be compatible with the meteoroid environment which, of course, means the structure will be resistant to meteoroid penetration. This requirement will be fully discussed in the paper on space-station structures (paper no. 4).

L
3
1
8
6

The last guideline, a reasonable lifetime, is not very specific but somewhere between 1 and 5 years is being considered. More data with respect to the lifetime of onboard systems must be obtained before a more specific guideline can be set up.

CONCLUDING REMARKS

The guidelines presented in this paper have established the basis for the space-station research program that is reviewed in subsequent papers.

ROTATIONAL PARAMETERS
AND HUMAN FACTORS

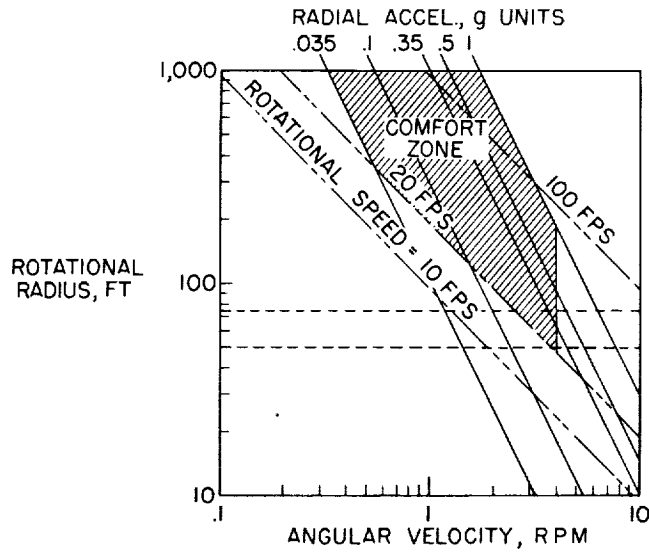

Figure 1

STABILITY CRITERIA

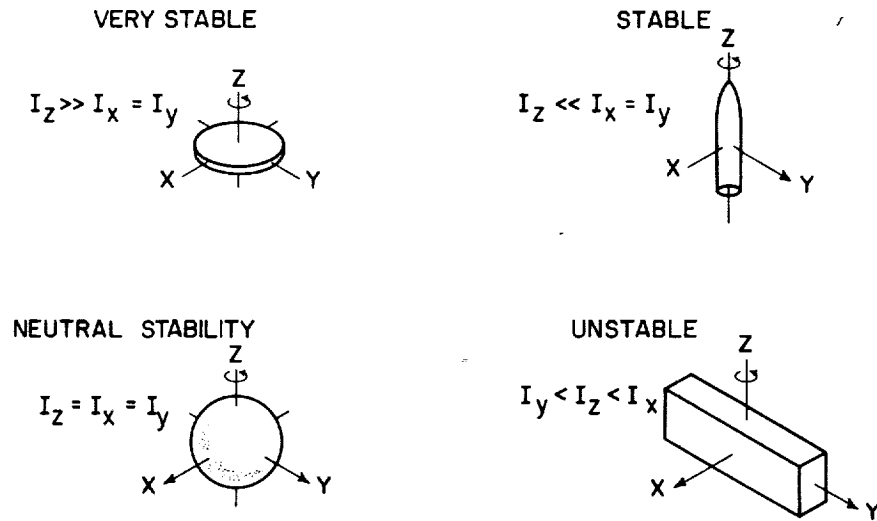

Figure 2

2. SPACE-STATION RESEARCH CONFIGURATIONS

By Rene A. Berglund

SUMMARY

L
1
3
8
6
The objective of the investigation was to determine the feasibility of a concept for an automatically deployed man orbital space station. The concept of the space station is based upon the use of a series of rigid modules hinged together which can be clustered for launch by a single launch vehicle. After the orbit has been established, the space station is automatically deployed; thus, in-orbit assembly is not required. The dimensions of the space station are sufficiently large to allow for artificial-gravity simulation with low rotational speeds. A zero-gravity compartment is incorporated at the rotational axes to allow for conduction of zero-gravity experiments.

The results of the studies indicate that a configuration which lies essentially in the plane of rotation - such as the "spoke" or "wheel" configuration - is desirable and that an automatically deployed space station with a rotational radius up to 75 feet is feasible.

INTRODUCTION

In an effort to advance the technology necessary for the eventual development of manned orbital space stations, various configurations have been investigated. For the configurations to be practical and operationally suitable, design criteria were based on the integrated variables of engineering, operation, and human factors. Analysis of the various configurations reveals the most desirable characteristics required for a feasible configuration and associated problem areas.

CONFIGURATIONS

The first configuration investigated at the Langley Research Center was a cylinder (fig. 1(a)). Artificial gravity is provided by rotation about the axis shown. Solar panels are extended as far as possible to make the moment of inertia about the spin axis greater than that about the other two axes. If this is not done, the cylinder will oscillate with extremely large amplitudes in roll or go into a continuous rolling

motion with slight disturbances. The cylinder is dynamically unsatisfactory unless there are major revisions in design; these revisions would lead to a new configuration, no longer resembling a cylinder.

The second configuration (fig. 1(b)) is a cylindrical space station attached to a terminal-stage booster. The purpose, of course, is the attainment of a large rotational radius. This arrangement has so many degrees of freedom that analysis of the dynamics is not easily resolved. The continual roll control which would be required would tend to give the station a short life. A vehicle of this configuration must be reeled in and simultaneously stopped for resupply or crew rotation. Thus, general considerations show this vehicle to have minimal capacities.

For the configuration shown in figure 1(c), the axes of the living modules are parallel to the axis of rotation. There are approximately 100 feet between modules, and the station is over 200 feet long. A nuclear power plant is situated at one end, and multiple docking facilities, at the other. This configuration is stable because the vehicle turns about its minimum axis of inertia. Numerous boosters are required for launching into orbit, where, after rendezvous, the components are assembled by space tugs. This concept might possibly be a space station for a future generation.

The "spoke" configuration (fig. 1(d)), which could have any number of radial elements greater than two, meets stability requirements since I_Z is greater than I_X and I_Y (where I_Z , I_X , and I_Y are moments of inertia about the Z-, X-, and Y-axis, respectively). This arrangement would have a different gravity force at each living level. Lower levels near the hub may not be suitable for habitation. A crew member moving from the tip of one spoke to another must move in and out in a radial direction, which may subject him to a disorienting Coriolis force.

In figure 1(e) the axes of the modules are parallel to the spin axis. Three modules are shown, but the design could include any number of modules greater than two. With this orientation of the modules there is no Coriolis force when the crew members walk from end to end, but there is a Coriolis force when one moves across the module. With this configuration it is possible to shift masses a considerable distance out from the plane of rotation; such a shift could cause substantial dynamic unbalance and wobble.

The wheel configuration, or torus (fig. 1(f)), is nearly an ideal configuration since it meets the requirement that I_Z be considerably greater than I_X and I_Y , making it dynamically a very satisfactory vehicle. This configuration has received considerable attention in these early studies. Since the space station lies essentially within the plane of rotation, mass cannot be shifted sufficiently to cause substantial dynamic unbalance and wobble.

Analyses of the basic configurations studied indicate that the wheel-shaped station with central hub and radiating spokes satisfies most of the requirements for the form of a space station.

Early studies covered inflatable or expandable spacecraft design. Such an inflatable station could be constructed, launched into orbit on a single launch vehicle, and, when in orbit, automatically inflated. An undesirable feature of this concept is that equipment cannot be installed in the proper places before launch. It would be necessary to store the equipment in the central hub. The crew would move it into place after inflation in orbit in order to satisfy stability requirements.

L
1
3
8
6

In contrast, the equipment in a rigidly constructed station can be installed properly before launch. Another favorable consideration is that the rigid station can be constructed of suitable material to provide adequate protection from the space environment. The most undesirable feature of this concept is the need for assembly in space. This need arises from consideration of human factors when simulating gravity at a low rotational velocity. A vehicle with sufficient radius to provide a moderate level of gravity (approximately 75 feet) cannot be boosted into orbit in one piece.

As a result of the configurational studies at Langley, the concept of an automatically erectable manned orbital space station was evolved. This concept combines the best features of the inflatable and rigid space-station concepts, that is, the compactness of inflatable designs and the prelaunch equipment installation features of the rigid designs.

Figure 2 shows the concept that was adopted for a contractual study. The erection sequence is illustrated from the launch configuration to the orbital configuration. The advantages of prelaunch equipment installation are retained through use of rigid modules connected by inflatable fabric structure. A compact launch configuration is obtained by folding the flexible fabric structure to allow the rigid modules to form a cluster, as shown in the upper left-hand corner of figure 2.

This automatically erectable station illustrates most of the problems associated with space stations and was used as a starting point for a feasibility study by North American Aviation, Inc. (NAA).

FEASIBILITY STUDY

The principal objectives of the study program were establishment of the technical feasibility and determination of the major design problems of the concept. Additional objectives of the study have included identification of critical technical areas, establishment of methods or

solutions to problems for each of these areas, and - insofar as possible - determination of the optimum solution of each problem and of the state-of-the-art advances required in each technical problem area.

During the 6-month NAA study, approximately 30 configurations were investigated. Since all 30 cannot be shown here, 3 designs that differ in deployment or geometry have been picked out for discussion.

Toroidal Configuration

In the toroidal configuration, illustrated in figure 3, curved rigid modules are joined by inflatable fabric structure. At first it was suggested that deployment of this space station be by pneumatic pressure with ladder-type cables to regulate erection velocity. It was subsequently concluded that this was not a good method of deployment because the motions or positions of the rigid modules could not be controlled. Each module is hinged at its midsection to reduce the effective diameter of the launch package. If the effective diameter were not reduced, the payload cross section would extend as far as the dashed line, resulting in an undesirable launch payload.

A space station could be designed with a completely rigid rim if the modules were mechanically hinged instead of using fabric structure for hinges between the rigid modules.

Modified-Hexagonal Configuration

In figure 4 the primary features illustrated in this arrangement are the completely rigid rim and a good launch configuration. The "pinched-in" portions at the three joints were a result of fairing the modules to form the launch contour. The station is deployed by mechanical actuators, placed at each hinge position; deployment must be phased to prevent binding of the hinges. This modified-hexagonal configuration still requires inflatable spokes for packaging.

In most of the configuration studies conducted by NAA, the number of modules making up the station was limited to six. Studies under structural analysis indicated that this number was optimum since weight trade-offs showed that a greater or lesser number of modules resulted in a greater total weight for the space station. Three spokes were considered to be the minimum number necessary to maintain the concentric location of the hub.

Hexagonal Configuration

The hexagonal configuration shown in figure 5 was selected by NAA for the final systems analysis. This configuration has all the advantages of the wheel configuration. The design includes rigid cylindrical modules arranged in a hexagonal shape with three rigid telescoping spokes. This configuration eliminates the requirement for exposed flexible fabric.

L
1
3
8
6

The modules are hinged together to fold into a compact cluster. The spokes are retractable to about one-half their original length and can be stowed in the cavity of the module cluster. This arrangement results in the launch configuration shown on the right side of the figure and is suitable for the desired launch on a single launch vehicle. A system of six compound hinges was devised at the Langley Research Center to connect the modules so that binding would not occur during deployment.

The space station is deployed from launch configuration into orbital configuration by a series of mechanical screw-jack actuators located at the joints.

Each module has an environmental system designed to accommodate six men continuously. However, if a defined mission required only a small crew, those modules not lived in by the crew could be used for storage and passage-ways or could be closed off. Since a pressure bulkhead and an airlock would be built between modules and at the ends of each spoke, the station would be divided into 10 compartments. If a malfunction or catastrophe occurs in any of these areas, the affected compartment could be isolated. Crew members in pressure suits could reenter through the airlocks to conduct repairs.

The volume of the space station results from consideration of the human factors which establish the rotational radius and the diameter of the living-working modules. Even though this volume of approximately 45,000 cubic feet is quite large, the compilation of weights by NAA indicates that the total weight of the base-point configuration would be approximately 171,000 pounds (table I). The present anticipated payload capability of the advanced Saturn is 210,000 pounds. The difference represents a rather high margin for weight growth, which invariably occurs.

Docking Facility

By varying the design of the station hub, docking provisions can be provided for various numbers of Apollo ferry vehicles. NAA has established feasibility of docking facilities for two, seven, and nine vehicles; however, docking-facility arrangements will be a function of the number of crew members on the station and the capacity of the ferry vehicle.

The most ideal docking position on the rotating space station is on the axis of the hub. If ferry vehicles are located elsewhere, they must be placed symmetrically to avoid a shift of the spin axis. The technique devised for moving vehicles from the docking position to a stowage position must prevent any mass unbalance that would create a wobble in the space station. A number of techniques to accomplish the multiple vehicle docking were considered.

A docking facility to accommodate a maximum of seven ferry vehicles is illustrated in figure 6. When the vehicle approaches the space station, the docking attachment is brought to a stop by driving it in a direction opposite to the space-station rotation. The vehicle which was launched with the station is moved to one side. The second vehicle docks and is moved to a position diametrically opposite the first. The docking attachment is then permitted to approach the station rotational velocity and the crew members exit to the hub by means of tubes which are extended to the ferry airlock. They can exit from the ferry vehicle onto the hub axis or the circumferential ports. During many operations, the vehicle simply docks on center, discharges a crew and supplies, picks up the passengers, and leaves.

NAA does not believe it feasible to counter rotate the turret continuously because of the power consumption involved and the difficulty in lubricating the bearings, which are exposed to the vacuum.

A cross section of the hub (fig. 7) shows how the zero-gravity laboratory compartment of the hub can be isolated from the normal flow of traffic between the rim and the hub. It occupies the lower portion of the hub. As in the initial hub design, the compartment is suspended by bearings and mechanically driven opposite to the direction of the space-station rotation.

CONCLUDING REMARKS

The data available from these studies lead to certain conclusions:

In accordance with the established guide lines an erectable space station with rotational radius up to 75 feet is feasible.

A space station which lies essentially in the plane of rotation, such as the "spoke" or "wheel" configuration, is desirable.

Such stations would be capable of being launched and deployed from a single launch vehicle.

I
1
2
3
4
5
6

Inclusion of a nonrotating compartment to carry out zero- and artificial-gravity experiments simultaneously is feasible.

As a result of the studies by North American Aviation, Inc., and the Langley Research Center, a number of critical technical problem areas have been identified and examined. As studies of configurations are continued, more research is needed in the following areas: the requirements for self-deployment, equipment installation and integration, system reliability, logistics vehicles and docking, and environmental sealing of the various connections necessary to provide a controlled living environment to insure crew safety and comfort.

L
1
3
8
6

TABLE I
WEIGHT OF 150-FT-DIAMETER HEXAGONAL CONFIGURATION FOR
EARTH LAUNCH

	<u>WEIGHT, LB</u>
SPACE STATION STRUCTURE	75,000
ONBOARD EQUIPMENT	64,000
INTERSTAGE STRUCTURE	10,000
PERSONNEL TRANSPORT	22,000
	<hr/>
TOTAL	171,000

SPACE-STATION BASIC CONFIGURATIONS

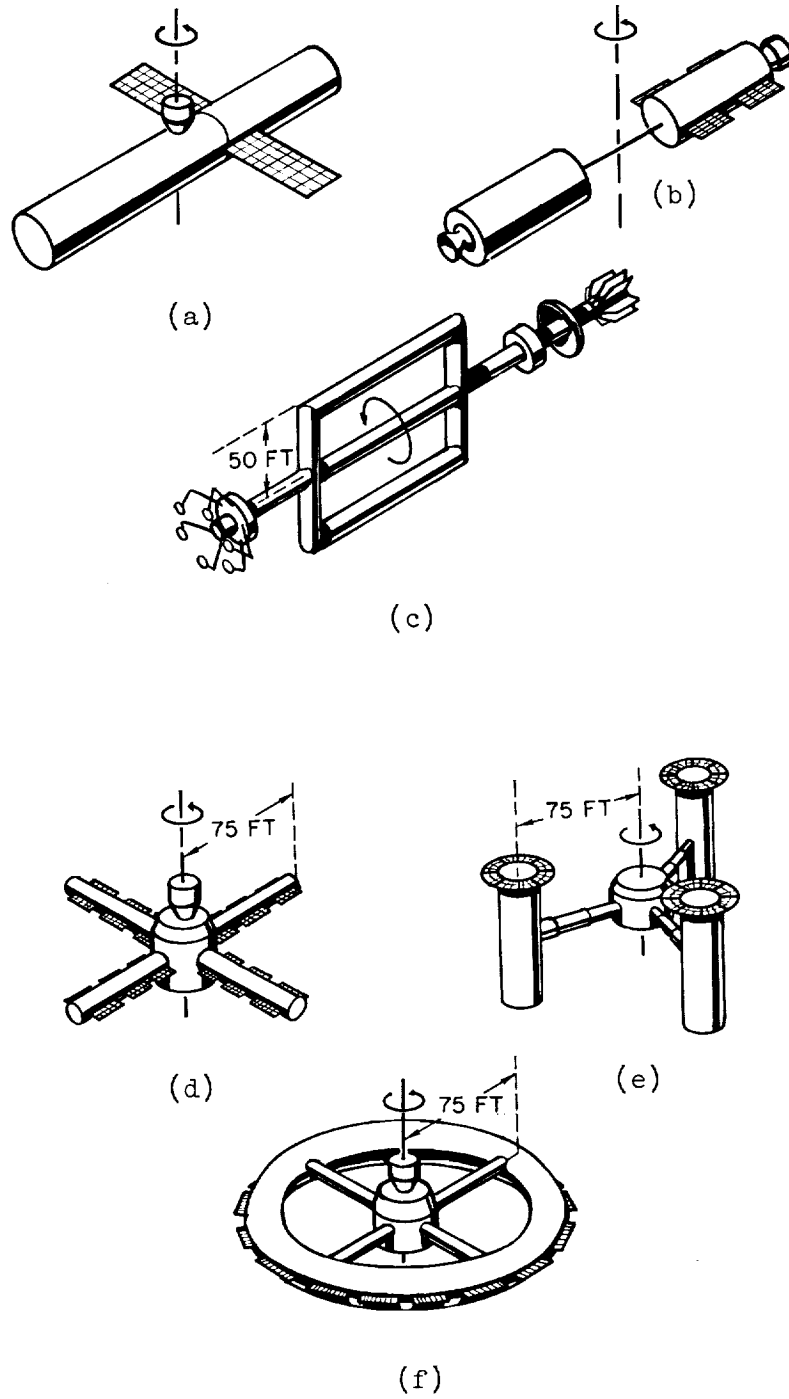

Figure 1

CONCEPT ADOPTED FOR STUDY

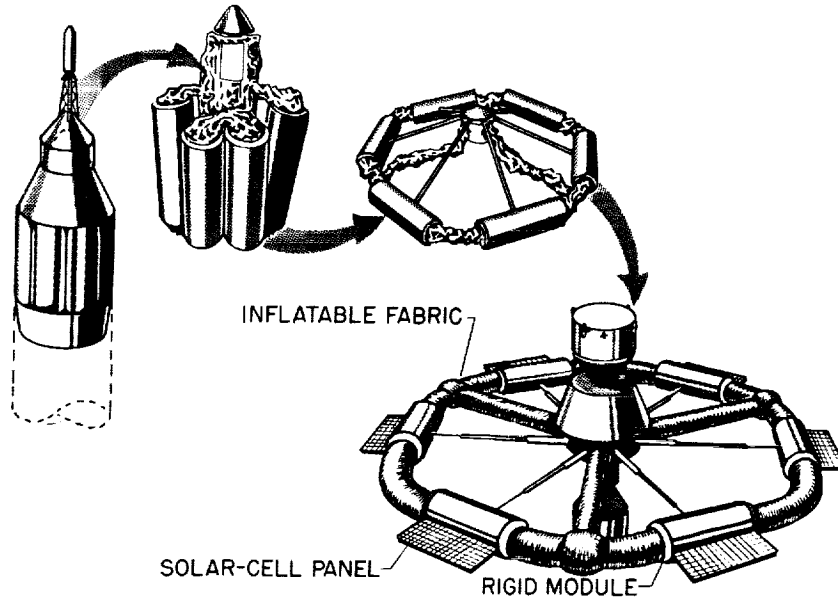

Figure 2

TOROIDAL CONFIGURATION

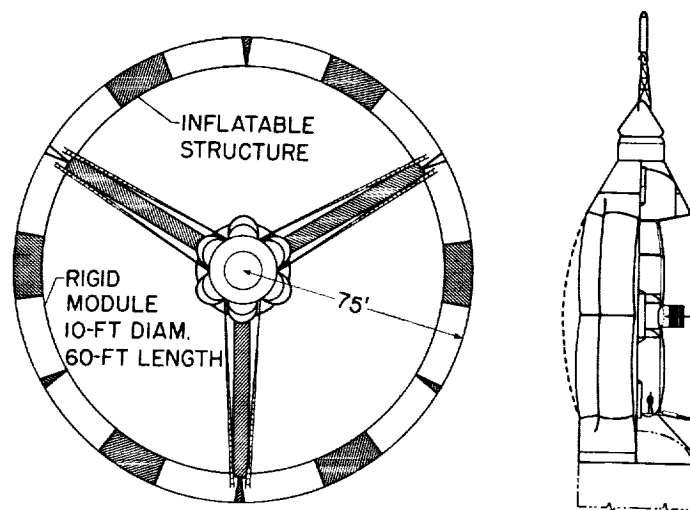

Figure 3

MODIFIED-HEXAGONAL CONFIGURATION

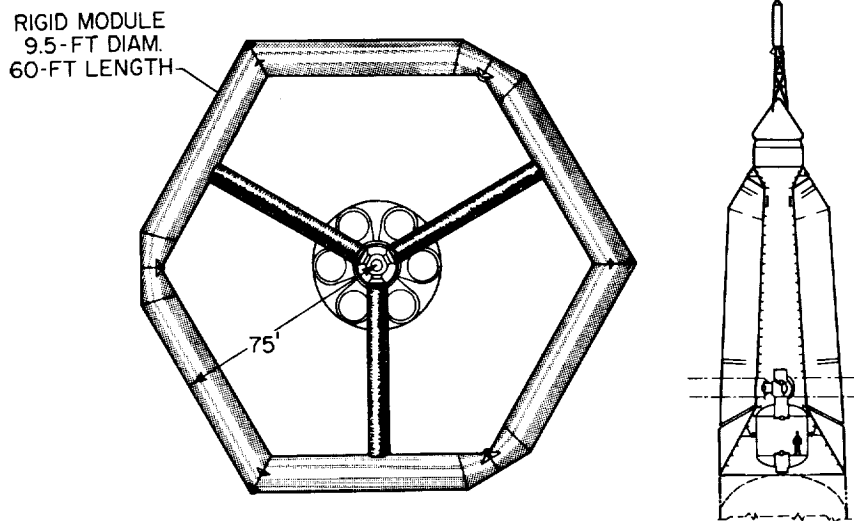

Figure 4

HEXAGONAL CONFIGURATION

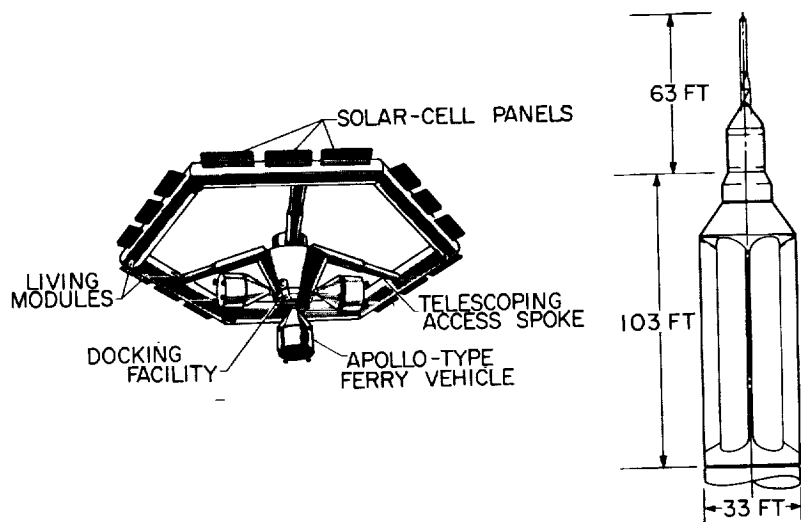

Figure 5

DOCKING FACILITY

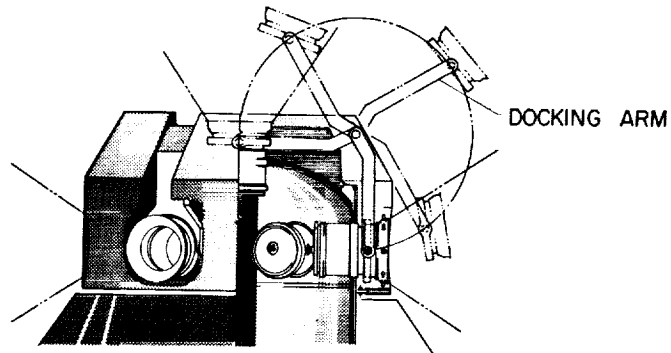
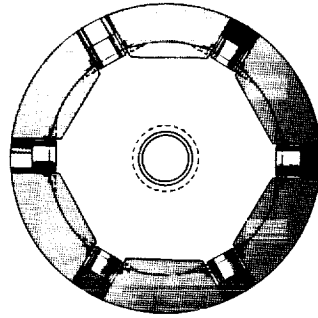

Figure 6

HUB SECTION

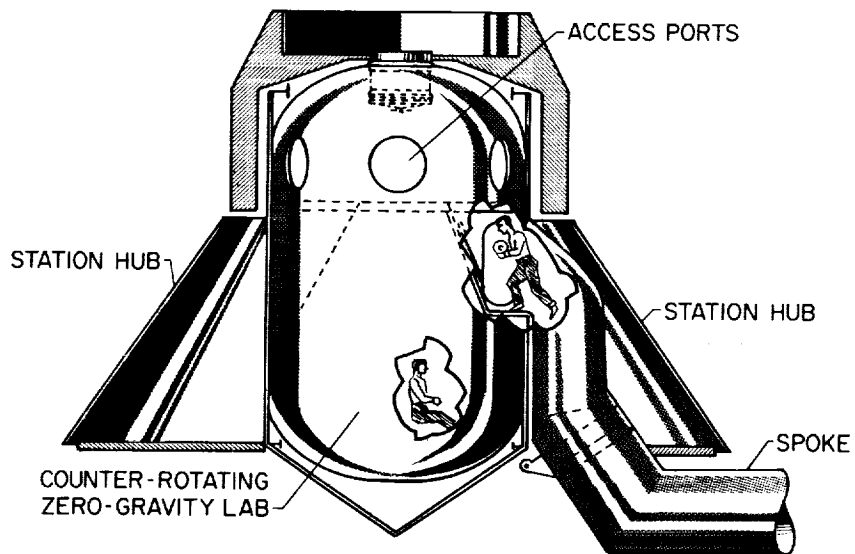

Figure 7

3. TEMPERATURE BALANCE OF MANNED SPACE STATIONS

By Lenwood G. Clark

SUMMARY

Temperature control of a manned space station to maintain a shirt-sleeve environment is a requisite for optimum working conditions and comfortable living. The thermal behavior of a given space station can be solved either by computation or by model test; both methods are discussed.

Model scaling theory and techniques for the experimental thermal analysis of two space-station configurations, one an inflatable torus (30-foot diameter) and the other a rigid modular self-erecting hexagon (150-foot diameter), are presented.

Characteristic experimental and calculated average wall temperature histories are presented for the torus station, whereas calculated inner and outer wall temperature histories for two wall designs of the hexagonal station are also presented. Space radiator rejection rates are also included.

INTRODUCTION

The thermal balance for a space station is particularly critical since, for comfort, the temperature must remain nearly constant over the entire orbit. This is in strong contrast with most other spacecraft in which wide variations in temperature are permissible.

Designing the space station for this fairly constant and uniform temperature is complicated by the facts that, except for heat generated internally by personnel and equipment,

- (1) Thermal input and output can occur only by radiation
- (2) With fixed orientation, certain areas are permanently oriented toward the sun, which is by far the strongest radiation source, whereas other areas are permanently in shadow
- (3) Because it alternates between sunlight and shadow during its orbital motion, the station is typically subjected to a (severe) periodic fluctuation in thermal irradiation

L
3
1
8
6

- (4) Because of precession of the orbit and because of seasonal variation of the earth-sun-orbit orientation, the details of this fluctuation can vary considerably with time.

The thermal problem, itself, will hardly influence the general configuration of the station, but it will have to be considered in the design of the wall, particularly the insulation and optical characteristics of the outer skin. In general, however, the thermal balance problem will not be solved completely by these means and some simple means of either adding or removing heat will still be needed.

The purpose of this paper is to review the methods of calculating the temperature within space stations, to review methods of measuring these temperatures by using thermally scaled models, and to mention some methods of helping to maintain livable temperatures.

L
3
1
8
6

THEORETICAL ANALYSIS

The methods of calculating the thermal history of the space station are considered first. Figure 1 shows in general terms the heat balance of the station as a whole.

For purposes of calculation, it is convenient to break the station up into a number of separate areas, and then consider the thermal input to each area as a function of time. The basic problem is a purely geometric one, since at each position in orbit there is radiation from the sun, radiation from the sun reflected off of the earth's surface, and earth thermal radiation, all striking the element of area at particular angles determined by the geometry. Leaving each area there is an amount of heat being radiated to space proportional to the fourth power of the absolute temperature of the surface.

Internally, there is heat from men and equipment being transferred to each area by radiation and convection. In addition, there is an exchange of heat between areas by one area conducting heat to another along the wall or by one area radiating to another area across the inside of the station. This type of radiation could also occur externally, in which case some of the areas would receive not only the direct radiation from the sun or the earth but also receive radiation reflected and radiated from the various other areas of the space station.

In the case of the 150-foot rigid modular self-erecting station (hexagon station), the radiation reflected from one area to another can be neglected since subtended angles are generally small. These angles are large, however, in the case of the 30-foot inflatable torus station,

and this reflected radiation could be appreciable and has to be taken into account.

L
3
1
8
6

Grumman Aircraft Engineering Corporation, under contract, conducted a theoretical thermal-balance study of the torus station and constructed a thermally scaled model for environmental testing at the Langley Research Center. In the study Grumman determined the radiation reflected from one area to another in the following manner. They built a scale model of the station and then put a solar cell on the area for which they wanted to calculate the radiation input. A beam of simulated sunlight was directed at the model of the station from the desired direction, and then the output of the solar cell corresponds to the total radiation that the cell "sees," which is both the direct and reflected radiation.

With the radiation exchanges defined plus knowledge of the thermal properties of the station's walls and the amount of heat generated internally by men and equipment, differential equations are written for each incremental area and then solved simultaneously over the orbit to obtain the temperature history of the station.

EXPERIMENTAL ANALYSIS

Another approach is the actual experimental approach in which a model of the station is placed in a vacuum chamber and irradiated with sources that represent the sunlight, the sunlight reflected from the earth, and the earth's thermal radiation. Also to represent the variation during orbit, the relative orientations of these radiations and the model have to be continuously varied. There again, simplifications are used. Because of symmetry in the hexagonal station, just one of the rigid modules is representative of the station. The model of this station is then a scaled model of a piece of one of the cylindrical modules. The model has insulated ends with reflective surfaces so that it behaves as though it were longer than it is.

In the case of the torus station the living quarters are shaded by a solar collector and never receive direct solar radiation. Accordingly, direct sunlight was not duplicated and the approach used was to calculate the temperature the collector would achieve in space and heat the model collector (spiral strip of aluminum) electrically to get it to that temperature.

Model Scaling

Dimensional analysis shows that the thermal history of the model will duplicate that of the full-scale station, if the scaling parameters

are the same for both the model and the full-scale station. The scaling parameters used in thermal-balance studies of spacecraft are $\frac{\sigma T^4}{I}$,

$$\frac{k}{L} \frac{T}{I}, \text{ and } \frac{t}{cL} \frac{I}{T} \text{ where}$$

T	temperature
σ	Stefan-Boltzmann constant
I	radiation intensity
k	conductivity
L	length
t	time
c	specific heat

L
3
1
8
6

In this analysis the optical properties used for the model surface should be the same as those on the full-scale station.

It seems not to be especially difficult to keep I, the thermal input per unit area, the same for the model as for the full-scale station, so that the temperatures will correspondingly be the same. In the second parameter with I and T constant, the conductivity k has to be proportional to the scale factor. In other words, for a 1/10-scale model, the conductivity of every material in the model should be one-tenth that of the full-scale material. This is perhaps the most difficult problem in the design of the model. The third parameter does not introduce any design problem; with I and T constant, it simply states that the time is proportional to the product of specific heat and length.

In general, however, as is the case with other problems, as long as the phenomena are understood the correct answer can be obtained without exactly duplicating these parameters.

In the case of the torus station, the walls were very thin (0.1 inch thick; dacron cords embedded in butyl elastomer) and the inner and outer wall temperatures were essentially the same; these conditions mean that the conductivity through the wall was very high and the conductivity along the wall was so low that if it were not correctly duplicated it would not matter. Accordingly, the same wall material was used as that for the full-scale station but with one-fourth of the thickness although

the model was otherwise one-twelfth scale. Since the mass per unit area was one-fourth of full scale, all times were correspondingly one-fourth of the full-scale value; thus, a 100-minute orbit was duplicated in 25 minutes.

In the case of the hexagonal station, the walls provide very good insulation and the problem exists of getting an insulator with a lower conductivity by the scale factor which may be 1/10 or 1/12. What will probably be done is to make the wall of the model one-fourth as thick as the wall of the full-scale station with one-fourth the conductivity. As was mentioned earlier, the entire hexagon will not be duplicated and the model will consist of a piece of one of the cylindrical modules.

Thermal Vacuum Facility

The thermal vacuum facility used in the experimental thermal balance investigations at Langley Research Center is shown in figure 2. The facility consists of a vacuum chamber 5 feet in diameter and 10 feet long having an inner liner which is cooled to -300° F by liquid nitrogen. The chamber can be evacuated to 10^{-6} mm Hg. Shown outside of the chamber is the model of the torus station built by Grumman and Goodyear Aircraft Corporation with the electrically heated solar collector; this collector is heated during the time the model is supposed to be in sunlight and turned off when the model is supposed to be in the earth's shadow. Earth radiation is simulated by a transparent lucite panel which was cooled to the mean temperature of the earth-cloud system (-9° F) by circulating cold nitrogen gas through a network of internal channels. Reflected sunlight from the earth is simulated by a modified 5-foot-diameter, 15-kilowatt arc searchlight having special high-intensity carbons to provide a spectrum approximating that of the sun. The radiation from this arc is directed into the tank through a special laminated safety-glass door (satisfactorily transmits the solar spectrum from 0.32μ to 2.65μ) where it illuminates the earth plate and passes through to the model. The concave surface of the earth plate is sandblasted in order to diffuse the radiation. The model itself has some heaters inside to simulate heat from men and equipment and a small fan to circulate the air. Throughout the tests the model spins as the full-scale station would to provide artificial gravity, and it also slowly turns on a vertical axis in order to go through its range of orientations relative to the earth plate. When it turns completely around, one orbit has been completed. The intensity of the arc source changes with the position of the model so that the input from earth-reflected sunlight is correct. Also as the model turns, it translates along the vacuum-chamber axis to provide correct "look" angles to the earth plate.

The experimental setup intended to be used in testing the hexagonal station is shown in figure 3. This setup is slightly different from that

L
3
1
8
6

previously discussed since for this configuration sunlight must be supplied. In this case the arc source provides sunlight with its radiation passing through the glass door and illuminating the top of the model. Earth radiation is supplied by a concave metal plate shown at the left end of the chamber. This plate with cooling coils attached to its rear surface is again maintained at the earth temperature. Reflected sunlight from the earth's surface also is supplied by the arc source since some of its energy strikes the earth plate and is reflected back to the model. The front of the earth plate must be properly coated to reflect diffusely the correct fraction of the radiation from the arc source to the model. The magnitudes and directions of the thermal inputs from both the earth-emitted and earth-reflected radiations vary during the orbit; this variation is simulated by rotating the earth-simulator plate about a vertical axis around the model. As the plate rotates the amount of radiation reflected from it diminishes and is virtually zero when the plate is in the plane of the paper. When the plate reaches the position where the station enters the earth's shadow, the arc source is turned off. Again the model continuously spins and has some heaters and a small fan inside. Although this test setup is intended for the hexagonal configuration, it is actually very general since many spacecraft are composed of cylindrical modules.

L
3
1
8
6

RESULTS AND DISCUSSION

In figure 4, experimental and calculated wall temperature histories for the torus station are presented. At the top of the figure is a sketch of the model showing the thermocouple locations. Thermocouples numbered 2, 3, 4, and 5 were located on the outer skin around the torus, while the solar collector was operated at a temperature in sunlight of 130° F. There was a total internal power dissipation of 20.8 watts, 19 watts from the heater and 1.8 watts from the fan. This value corresponds to 3 kilowatts for the full-scale station. The results are plotted in degrees Fahrenheit against position in orbit, starting with satellite noon, going through the earth's shadow, and back to noon.

The temperature histories of the thermocouples are indicated by the solid curves. The variation exhibited by thermocouple 3 indicates that the air circulation on the inner surface of the torus was very poor and very little heat was transferred in this region by convection.

Taking a weighted average of these temperature histories gives the experimental average skin temperature. To be compared with this temperature is the calculated average skin temperature as computed by the Grumman Aircraft Engineering Corporation.

As can be seen, the comparison between the experimental and calculated temperatures is not too good, and additional experimental work will be required before a really accurate comparison can be made. The experimental results shown are from the first tests of the torus model and there is some doubt as to whether the optical characteristics of the model were the same as those used in the calculations due to handling.

L
3
1
8
6

In figure 5, calculated wall temperature histories for the hexagonal station are presented. This figure shows the average temperatures of the inner and outer wall as computed by North American Aviation, Inc., for two wall designs of the hexagonal station. Again the plot is of temperature in degrees Fahrenheit against position in orbit. The dashed curves are for a 3-inch-thick wall composed of two layers of glass wool (density, 3.5 pounds per cubic foot) and a layer of aluminum honeycomb (density, 4.5 pounds per cubic foot). The solid curves are for a 2-inch-thick wall composed of a layer of polyurethane foam (density, 1.5 pounds per cubic foot) and a layer of aluminum honeycomb filled with foam.

The thicker wall is an excellent insulator and provides extremely uniform internal wall temperatures, and correspondingly extremely non-uniform external wall temperatures. The thinner wall is not such a good insulator and shows an internal wall-temperature variation of 25° . However, the internal air-temperature variation is probably much less than this value; North American did not actually give the results for the air temperature but presumably considered that the variation would be small enough not to be objectionable. Note that the average inner wall temperature for this case is about 15° less than the average for the thicker wall; this is a real advantage since more of the internal heat is given up to the cold wall and the size of the external radiators is thereby reduced. (The thicker wall required a radiator rejection rate of 2,988 Btu/hr whereas the thinner wall required a radiator rejection rate of 2,075 Btu/hr.) However, this wall temperature should not be so low as to allow moisture to condense on the wall as it would in this case (dewpoint of 55° F). Furthermore, it is not known whether a room with cold walls would be comfortable even when the air in the room is warm.

CONCLUDING REMARKS

The thermal behavior of a given space station can be solved either by computation or by model tests. Neither approach is simple; both require further development.

With regard to the thermal and optical characteristics desirable for the walls, generalizations cannot be made. Some degree of insulation will be desirable, and since an outer micrometeoroid bumper will

be needed in any case, the insulating and protective type of wall proposed by North American Aviation, Inc., is probably representative. For such a design, the average wall temperature will be somewhat below the air temperature; therefore, some heat is lost to the wall. However, a radiator and cooling system will still be needed to remove the remainder of the internally generated heat.

THE TEMPERATURE PROBLEM

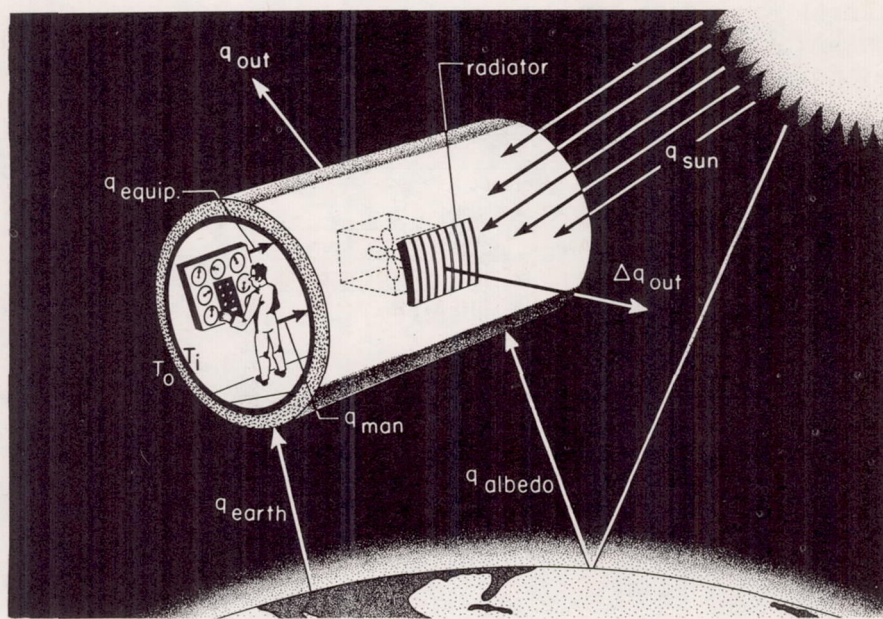

Figure 1

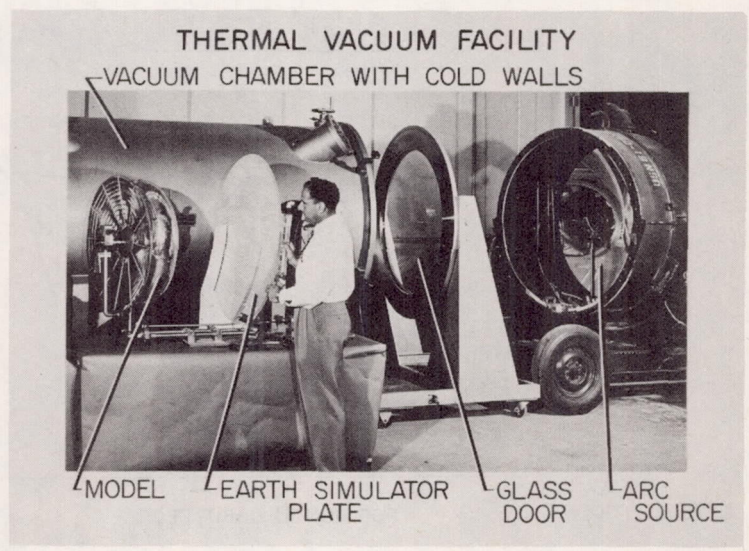

Figure 2

L-62-3793.1

THERMAL-TEST SETUP

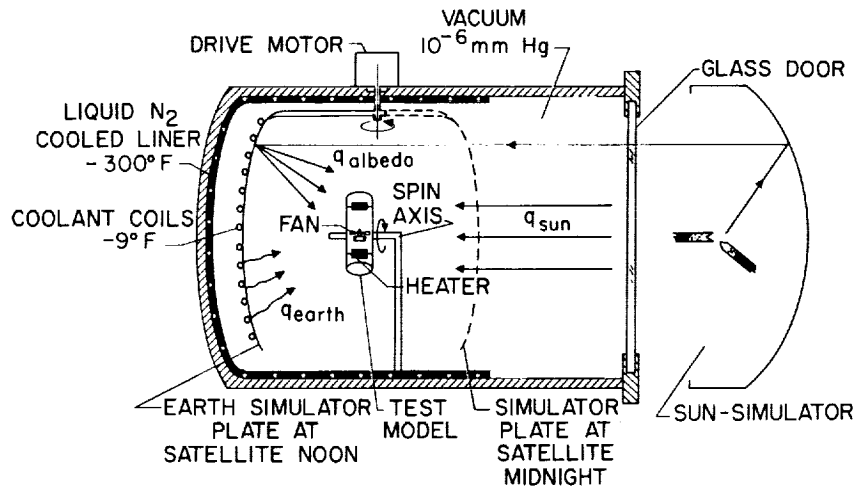

Figure 3

TORUS WALL TEMPERATURE HISTORIES

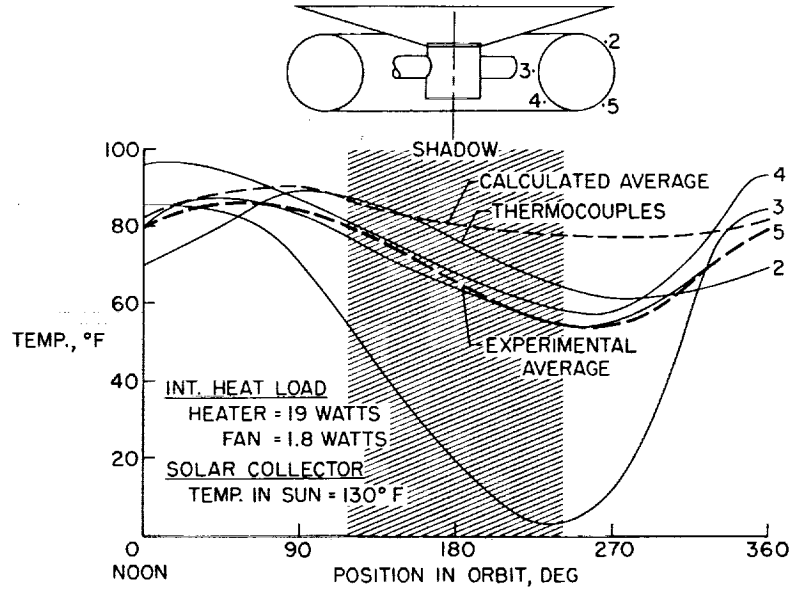

Figure 4

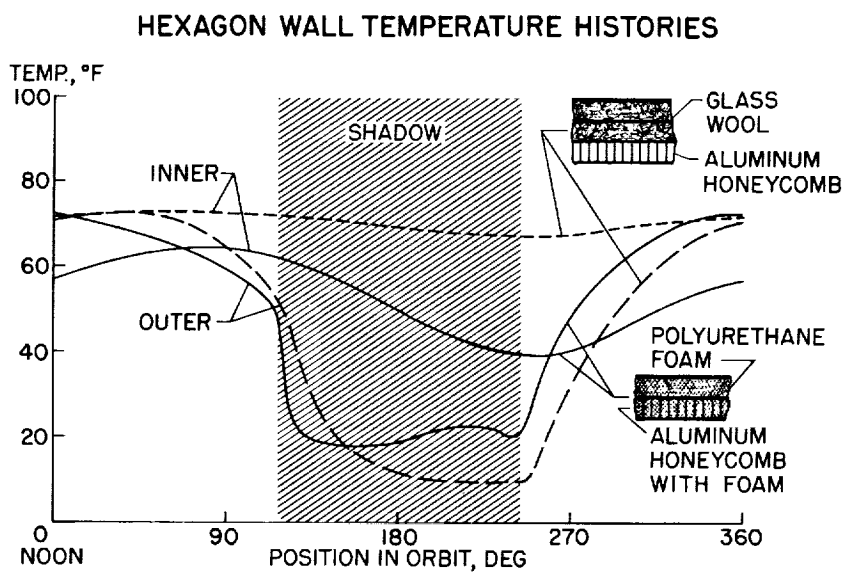

Figure 5

4. STRUCTURAL REQUIREMENTS OF LARGE MANNED SPACE STATIONS

By George W. Zender and John R. Davidson

SUMMARY

Current knowledge of the meteoroid hazard and the results of penetration studies are reviewed. A basic structure which appears promising for the walls of a large manned space station is designed to provide meteoroid protection and is analyzed for its load-carrying ability; these loads are then compared with the maximum loads to which the space station is likely to be subjected. The results show that the weight required for the walls of the space station is determined by the protection required for meteoroids.

INTRODUCTION

The present limited knowledge of space environments causes severe uncertainties regarding the basic structure of manned space stations. Of particular concern are the hazards presented by radiation and meteoroids; present estimates of the magnitude of these hazards vary widely. Such wide variations naturally affect the design of the structure. This paper presents current information on the space environment in the vicinity of the earth and on the structure required by a large space station to survive such an environment. The structure is first designed to withstand the environment, and the resulting configuration is analyzed for its load-carrying ability; the permissible loads are then compared with the maximum loads to which the space station is likely to be subjected.

SYMBOLS

E	Young's modulus
h	depth of honeycomb sandwich
N	number of punctures
P_i	compressive load per unit length of circumference
p	pressure

r	radius of cylinder
t	total metal sheet thickness in wall
t_s	thickness of one face sheet of sandwich
σ_1	stress in inner skin of sandwich
σ_2	stress in outer skin of sandwich

$$\sigma_{AV} = \frac{\sigma_1 + \sigma_2}{2}$$

ψ	elastic modulus of sandwich core measured in depthwise direction
--------	--

L
3
1
8
6

SPACE-STATION ENVIRONMENT

The ionizing radiation environment to which future space stations may be exposed consists of trapped radiation in the Van Allen belts, cosmic rays, and solar-flare particles. Present technology indicates that very heavy structures are required to protect human life from such radiation and, hence, that difficult engineering problems may lie ahead. However, it is known that the radiation problem may be avoided if certain limitations are placed upon the altitude and inclination of the orbit of the space station to take advantage of the protection afforded by the Earth's magnetic field. Such limitations have been placed upon the space station under consideration, and, for this reason, no further discussion of radiation is considered herein. However, the need for protection against meteoroids cannot be postponed and demands immediate attention.

The meteoroid hazard is dependent upon two major factors: the flux rate of the various sizes of meteoroid particles and the amount of damage a specific particle can inflict on a structure. Current knowledge of the flux rate of particles is shown in figure 1. The two solid lines in figure 1 represent high and low estimates of the meteoroid flux, based upon the extrapolations from photographs of meteors reported in references 1 and 2. The data from reference 2 have been modified slightly in the light of more recent data which indicate that the upper-limit curve may not pass through the microphone data points. The circles represent microphone data collected from satellite experiments whereas the squares and the dashed line represent satellite-damage experiments on wire-wound cards and on sheet metal. Note that the direct-damage experiments indicate a much lower meteoroid flux than do the microphone data and that the micrometeoroid satellite S-55

(Explorer XIII (1961 Chi)) line, which is an upper-limit boundary for this experiment, lies near the lowest estimate. None of the direct-damage-measuring satellites were in orbit for more than 2 days; thus, the reliability of these data is limited. Nevertheless, there does seem to be a trend toward lower estimates of the flux.

L
3
1
8
6

The uncertainty in the mass and rate of occurrence of these meteoroid particles means that any attempts to design a structure to protect a spacecraft's crew and equipment will probably result in either an inadequate or an overdesigned structure. As an example of the uncertainty involved, the weight of a space-station wall designed by using the upper estimate of the flux is double that of a wall designed by using the lower estimate. The NASA has recognized the need for defining the actual rate of puncture on structural materials such as aluminum and steel. The NASA Langley Research Center is planning to launch a direct copy of the Explorer XIII, and two similar but more refined vehicles are presently being considered. The thicknesses of the beryllium copper and stainless-steel sheets are such that they will measure the penetration flux from meteoroids whose masses lie in the range between 10^{-9} and 10^{-6} grams. A larger vehicle for testing aluminum thicknesses near 10 mils is being studied. Although it is desirable to ascertain the penetration flux for masses of 10^{-5} grams and larger because such particles would penetrate commonly used aluminum sheet thicknesses of 30 mils, the huge area required presents problems of weight and deployment. As yet, no practical flight experiment has been proposed in which a definitive penetration rate can be obtained directly on thicknesses of 30 mils.

METEOROID PENETRATION

Figure 2 presents some results of recent penetration studies made at the NASA Ames Research Center for several possible structural configurations which might be used either individually or in combination for the space-station wall. Ground tests of these configurations have been limited to velocities up to 23,000 feet per second by the performance capabilities of the guns; consequently, because of the lack of data at meteoric speeds, which are more than four times the test velocities, it is necessary to assume that the relative stopping efficiencies among the configurations is the same for meteoroids as for the ground impact tests. The right-hand column of numbers in figure 2 indicates the ratio of the weight of sheet metal required to stop a projectile to that required for the simple single-sheet wall. Experiments at the NASA Ames and Langley Research Centers have demonstrated that large benefits are derived by dividing the structure into two separated sheets; the first sheet shatters the projectile, and the hemispherical blast emanating from the impact area diminishes in intensity as it spreads while crossing the gap, thus distributing the

energy over a large area of the back sheet. The gap distance must be at least a certain minimum to make use of the benefits of the bumper shield. The stopping ability of the double-sheet configuration, however, is not greatly influenced by small variations in the relative thicknesses of the front and back sheets from the equal values shown in figure 2. It is indicated in figure 2 that a two-sheet structure weighs only 29 percent of the weight of a single sheet with the same stopping power and that a three-sheet structure weighs only 27 percent of the single-sheet weight. Two sheets with a polyurethane plastic filler are even better, requiring only 16 percent of the weight of a single sheet. On the other hand, a honeycomb core is detrimental. The cells of the core channel and focus the blast from the bumper onto the rear sheet; thus, this structure is heavier than any of the others - up to 90 percent heavier than the single sheet. The appended question marks indicate that the numbers were not obtained directly from tests, but were calculated by combining the results from several sets of different tests; thus, there is some resultant uncertainty in the values.

L
3
1
8
6

This weakness and especially the low velocities associated with these data underscore the need for further penetration research. Efforts are being made to obtain higher velocity data through the development of promising new techniques for accelerating particles. One of these ideas is the use of high-voltage electricity to explode metal wire or foil. Studies at the Langley Research Center indicate that an exploding-metal-foil facility can be designed to attain velocities of 50,000 feet per second.

Figure 3 shows space-station wall configurations which now appear to be attractive from the standpoint of meteoroid protection. The advantages of double walls and foam filler have been shown and thus could be considered for the space-station wall. Three sheets with foam would be slightly better. The configuration at the bottom of the figure adds a honeycomb sandwich core to the three-sheet configuration with foam filling retained throughout. The poor meteoroid stopping qualities of honeycomb are considered to be offset somewhat by the presence of the outer shield and the foam filling in the honeycomb cells; this structure is not considered to be much better than a simple two-sheet structure because of the presence of the honeycomb. However, the honeycomb sandwich is a good lightweight structural form. Therefore, the lower configuration in figure 3 appears to combine good meteoroid protection with good load-carrying ability and thus represents a reasonable choice for the wall design of a large manned space station. In the remainder of this paper, attention will be confined to the lower configuration.

Based on the composite honeycomb configuration, the total sheet thickness required to stop meteoroids has been determined and is

L
3
1
8
6

indicated in figure 4. The calculations of the expected penetrating flux for a given total sheet thickness were made based on the high and low estimates of meteoroid flux. These values are plotted against the total thickness of the aluminum sheets. Arbitrarily, a design level has been chosen where there will be a 50-percent chance of not having any punctures within a year in orbit. Based on the high and low estimates, the total aluminum skin thickness lies somewhere between 0.040 and 0.125 inch. This sheet thickness range is strongly dependent upon both the vehicle reliability and the number of punctures which can be tolerated as is shown in figure 5. The abscissa shows the probability of exceeding N punctures in a one-year orbit and the ordinate is the weight in relation to the design point of 0.5 reliability and zero punctures as shown by the square. Note that the aluminum sheet weight can be halved if five punctures per year can be tolerated. Because of the decided weight advantages in allowing a small number of punctures, North American Aviation, Inc., in its contractual study permitted five or so punctures to reduce the wall weight. Such an approach is very feasible because, even if the wall were designed for a probability of zero punctures, some means for repairing unexpected holes must be provided. Note that, if the station is designed for zero punctures and 50-percent reliability, there is little chance of exceeding five punctures in a year's time.

The configuration which results from the meteoroid study is depicted in figure 6. It consists of a meteoroid bumper backed with 1-inch-thick polyurethane foam and a 1-inch-thick honeycomb sandwich for carrying loads as well as resisting meteoroid penetration. Both the meteoroid shield and the honeycomb core are filled with polyurethane foam. The North American Aviation, Inc., design specifies a foam density of $\frac{1}{2}$ pounds per cubic foot and is based on projectile tests. However, the choice of a proper foam density presents some problems which will require investigation. For example, there is the possible breaking up of the foam due to vibrations during launch. For this reason, no specific foam density is suggested here. The two aluminum skins of the honeycomb sandwich are of equal thickness whereas the aluminum bumper skin is one-half this thickness. The total thickness of the aluminum as prescribed by the low and high estimates of the meteoroid flux is shown in figure 6 by the minimum and maximum thicknesses, respectively. In addition, the total thickness of the North American design is indicated.

STRUCTURAL CONSIDERATIONS

The structure shown in figure 6 has been chosen largely from consideration of meteoroid penetration and therefore must be evaluated regarding its ability for sustaining the loading and the thermal

environment to which it will be subjected. Aerodynamic heating occurs during launch, and radiative heating on the sun side occurs in orbit while the opposite side is cooled by radiation to outer space. This radiative differential of temperature appears to be more critical than the aerodynamic heating. Neither induce thermal stress of concern but the radiative heating and cooling may cause a bending and rotation of the modules which could be extremely undesirable. The cycling of this bending and rotation as the station alternately is exposed to the sun and then shaded by the earth must receive considerable attention. Much of the rotation can be eliminated if the joint design at the module ends is such as to permit thermal expansion and contraction of the module walls.

Critical loads occur from thrust and bending during launch and from internal pressures. Sandwiches are sometimes avoided as pressure vessels because of concern regarding the ability of the sandwich core to transmit pressure loads to the outer skin. The requirements of the sandwich core to perform this function are shown in figure 7. The ratio of the stress in the outer skin σ_2 to the average stress σ_{AV} is plotted against a parameter which represents the crushing stiffness of the core. (Note that the parameter increases in the reverse direction to that usually shown.) For large values of the core stiffness parameter, the outer skin carries the same stress as the inner skin. Thus, this is the region in which the sandwich skins are acting as a unit in carrying the pressure loads. However, as the core stiffness parameter decreases, the stress in the outer skin decreases as indicated by the curve. The area labeled "conventional sandwich construction" indicates the range of core stiffness for which a sandwich behaves as a structural unit in carrying compressive and shear loads. Since the curve does not drop off appreciably over this range, the conventional sandwich apparently also operates as a structural unit for pressure loads. Therefore, sandwich cores designed to provide structural integrity for axial and shear loadings appear to be adequate for pressure loadings. The particular sandwich core proposed by North American is indicated by the square in the figure. It is apparent that this design is well within the range where the two faces behave as a unit. The range of initial stiffness provided by rigid foam cores is also shown in figure 7. Creep, which must be considered for foams, will move the indicated range even further to the right. Hence, it appears that foam-type cores, such as proposed for the outer portion of the meteorite shield may be fairly ineffective in transmitting pressure loads for long-time applications, and for this reason the outer skin, or bumper, is neglected when the strength of the wall is calculated.

The relative importance of the various design conditions is summarized by the weight-strength plot shown in figure 8. The ordinate is the weight of the aluminum honeycomb sandwich per square foot of

surface area, and the abscissa is the structural index. (The weight of the bumper shield was not considered because it is assumed that the shield does not aid in supporting loads.) The structural index parameter is the compressive load per inch of circumference of the module divided by the module radius. In this plot, all acceptable designs must fall within the area indicated on the upper right because of the following considerations. The slanted line is obtained from the compressive yield strength of the material and therefore shows the lightest possible weight for carrying compressive loads. Consequently, all designs will plot above the slanted line. The horizontal line indicates the weight of the sandwich required to carry the internal pressure and therefore all acceptable designs must plot above this line. The vertical line indicates the highest static compressive loading which occurs from thrust load and bending of the modules at the maximum dynamic pressure loading during launch. Other loading conditions during launch produce smaller compressive loads in the module, and the loads during orbit appear to be even less critical; therefore, all satisfactory designs must plot to the right of the vertical line. Thus, the bounds for acceptable designs are defined by the hatched lines. The circles show the designs arrived at earlier from the meteoroid studies. The uppermost circle represents the maximum thickness and the lower circle, the minimum thickness. Because both points are based on a 50-percent probability of zero penetrations in a year, the spread in the points indicates the degree of uncertainty regarding meteoroid penetration. Also shown (by the square) are the weight and strength calculated for the North American design. It is evident that any of these designs is adequate for carrying the internal pressure and the launch loads.

Figure 8 is based on a honeycomb sandwich of an aluminum alloy at a temperature environment of about 300° F. This temperature may appear somewhat high in view of the thermal protection offered by the meteoroid bumper filler. However, some form of connection between the outer and intermediate skins is required, and such connectors may considerably offset the insulating effect provided by the bumper. In view of the possible effect of such connectors, the material properties used herein are based on the temperature of 300° F (which is also the value employed in the North American studies). Uncertainties exist in regard to the use of structural adhesives at this temperature or in a space environment. Therefore, the question of whether a bonded aluminum honeycomb sandwich can endure the environment and provide structural capabilities is open to argument. Some consideration should be given to other materials which can be fabricated without the use of organic adhesives. The compressive and pressure load capabilities of the more temperature-resistant materials such as steel do not suffer from as great a reduction of material properties at the space-station design temperature as that which occurs for aluminum. Therefore, such materials which result in heavier structures at room temperature might appear just as favorable for the design temperature.

CONCLUDING REMARKS

The results presented have shown that the basic design of the walls of the space station is determined by the protection required for meteoroids, but that the necessary structural weight is uncertain by a factor greater than 2. The total metal sheet thickness of the space-station wall proposed by North American Aviation, Inc., falls between the maximum and minimum thicknesses necessary to provide protection from meteoroids and, hence, appears to be reasonable based upon current inadequate knowledge. The fact that the meteoroid environment has an overriding effect upon the design of the space-station structure emphasizes the already-recognized need for further research to obtain a more accurate knowledge of the meteoroid hazard.

L
3
1
8
6

REFERENCES

1. Watson, Fletcher G.: *Between the Planets*. Rev. ed., Harvard Univ. Press (Cambridge, Mass.), 1956.
2. Whipple, Fred L.: *Particulate Contents of Space*. Medical and Biological Aspects of the Energies of Space, Paul A. Campbell, ed., Columbia Univ. Press (New York), 1961, pp. 49-70.

METEOROID FLUX

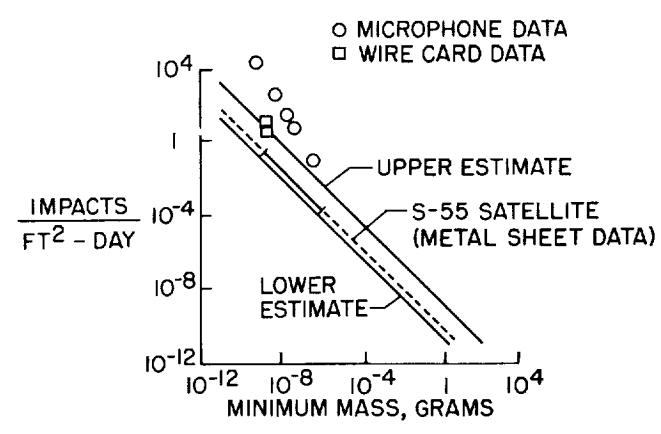

Figure 1

RELATIVE WEIGHT TO PRECLUDE PUNCTURE



CONFIGURATION	RELATIVE WEIGHT
 t	1.00
 t/2 } t/2	.29
 t/3 } t/3 } t/3	.27
 t/2 } t/2	.16 (?)
 t/2 } t/2	1.90 (?)

Figure 2

DESIGN CONFIGURATION DEVELOPMENT

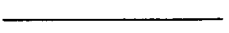
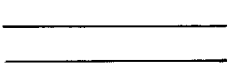
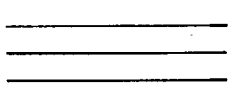
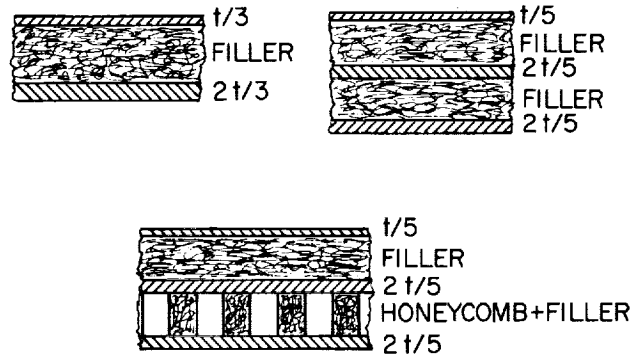

Figure 3

THICKNESS REQUIREMENTS

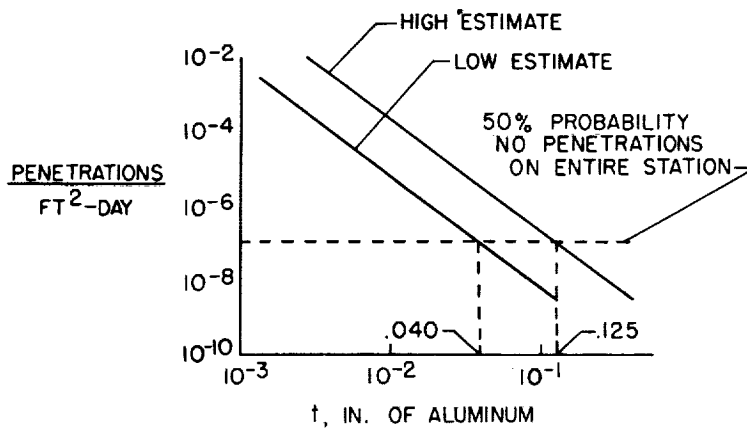

Figure 4

EFFECT OF ALLOWED NUMBER OF PUNCTURES PER YEAR

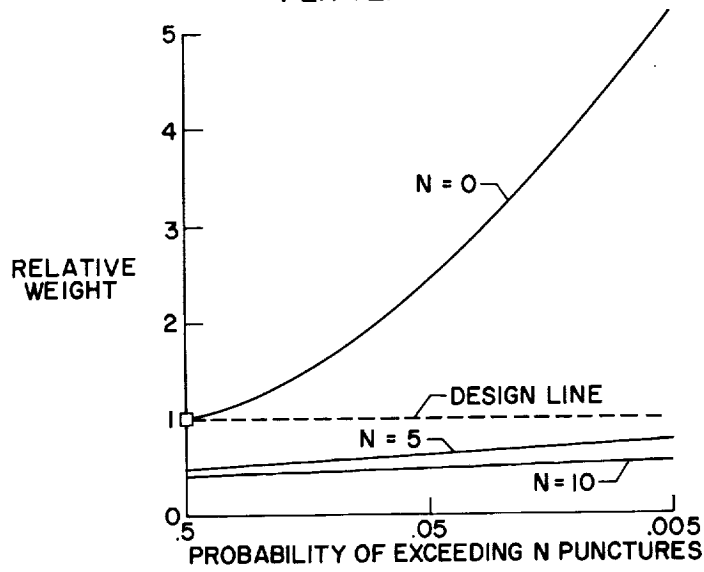

Figure 5

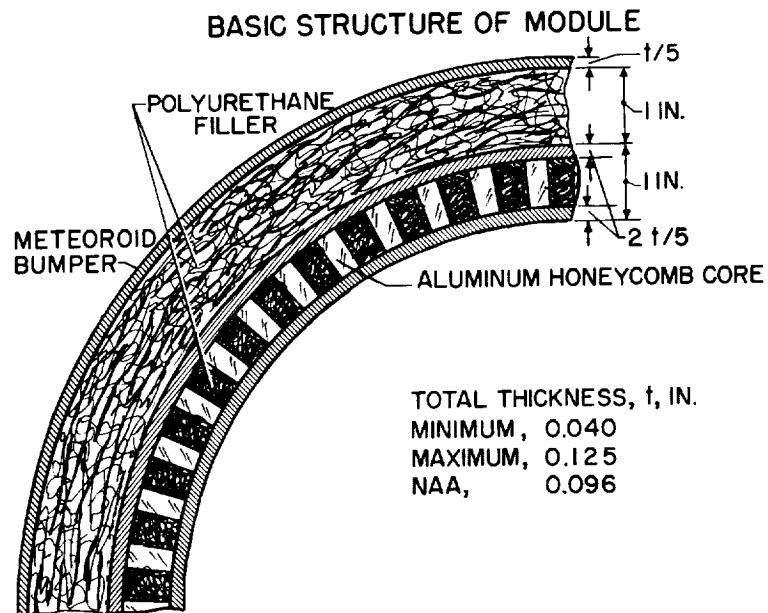

Figure 6

EFFICIENCY OF PRESSURIZED SANDWICH SHELLS

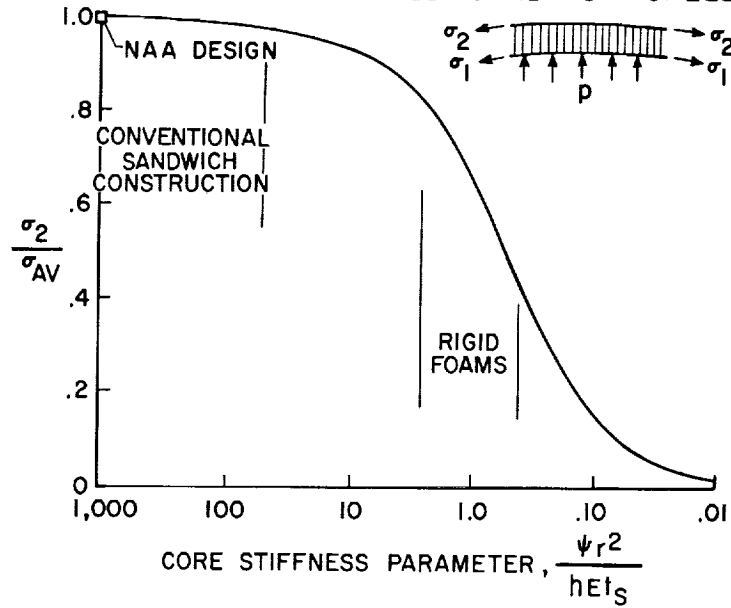

Figure 7

WEIGHT-STRENGTH OF SANDWICH MATERIAL

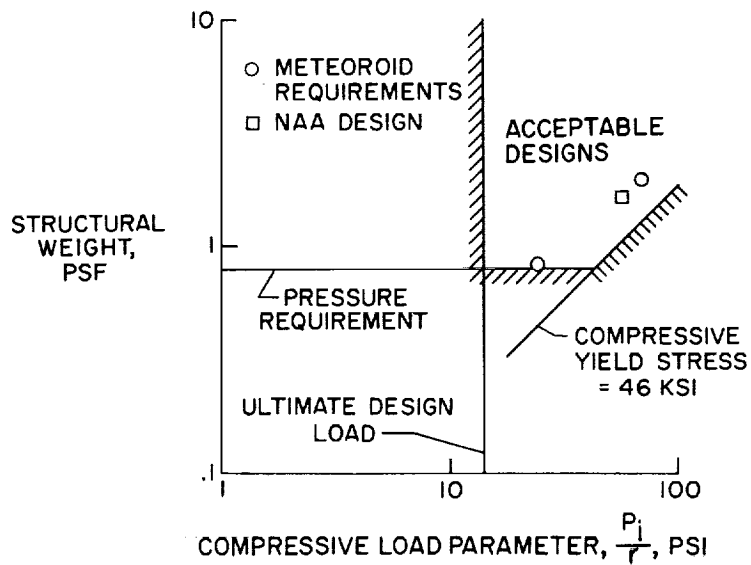

Figure 8

5. MATERIALS AND FABRICATION TECHNIQUES FOR MANNED SPACE STATIONS

By Robert S. Osborne and George P. Goodman

SUMMARY

L
3
1
8
6
This paper presents a summary of research being carried out on materials and fabrication techniques for constructing the walls of the living quarters of manned orbiting space stations. It also indicates problem areas where additional research is required.

Wall materials which have high strength-to-weight ratios and which are foldable have been constructed using filament-cage-and-bladder, filament-winding, and pattern-layup techniques. Several elastomer-cord materials have been exposed to a hard vacuum for up to 140 days with only minor losses of weight or strength. Structural metals would generally be unharmed by the space environment at space-station orbital altitudes. Surfaces, however, would be affected by sputtering and ultraviolet radiation. Tests have indicated sheet metals and welds are generally impervious to air leakage; however, riveted joints, flexible fabrics, and rotating seals are leakage problem areas.

5

INTRODUCTION

One of the important problem areas in the development of manned orbiting space stations concerns materials and fabrication techniques for constructing the walls of the living quarters of the space station. The purpose of this paper is to summarize the research being carried out in this area and indicate where additional effort is required. Whether these walls are constructed entirely of rigid materials or of a combination of rigid and flexible materials, they must have a unique and exacting set of properties. In general, the materials used must be compatible with the space environment, be nonhazardous to man, and have a high strength-to-weight ratio.

Specific factors determining materials and structures requirements for erectable manned orbiting space stations are outlined as follows:

Loads:

- Launch dynamic
- Erection
- Internal pressure
- Orbital dynamic
 - Stabilization impulses
 - Docking impacts
 - Crew and cargo shifts

Manned occupancy:

- Minimum gas leakage
- Nontoxicity
- No unpleasant odors
- Self-sealability

Space environment:

- Temperatures (-50° F to 150° F)
- Hard vacuum ($p \approx 10^{-8}$ mm Hg)
- Electromagnetic radiation
- Particle radiation
- Micrometeoroids

Prelaunch and launch environments:

- Humidity as high as 100%
- High temperature
 - Ground - 140° F
 - Launch - depends on shroud
- Sand and fungus
- Salt atmosphere
- Extended storage

Inflatable structures:

- Repeated foldability
- Inflation loads

Miscellaneous:

- High strength-to-weight ratio
- Tear resistance
- Easy repairability
- Combustion resistance
- Readily coatable

Briefly, the walls will be required to withstand a hard vacuum; the pressure p at an altitude of 300 nautical miles is only of the order of 10^{-8} mm Hg. The high-energy particle radiation hazard is not considered a major problem since exposure can be minimized by keeping the orbit of the station beneath the Van Allen belt. However, sputtering

and ultraviolet radiation may have a large effect on surface optical properties. Of the many materials and fabrication problems, the minimization of leakage to maintain cabin internal pressure over long periods of time appears to be one of the greatest, and serious attention is being given to this problem.

It is apparent upon considering these requirements that several materials may be needed to construct the walls of a space station. A typical wall section will probably be of the multilayer or composite type for either rigid or inflatable structures. The various layers (starting from the inside) might include a coating to furnish interior color and abrasion resistance, a coating to minimize gas leakage, elements designed to carry the structural loads, layers having insulative and self-sealing properties, a micrometeoroid bumper and, on the outside, a coating for temperature control.

METHODS OF CONSTRUCTION

Configuration studies have indicated that a space station might be shaped like a torus. The first approach in the construction of such a space station was to use an inflatable structure, and several ways of constructing the load-carrying portion of such a structure have been investigated. As previously indicated in paper no. 2, it now appears feasible to construct a torus of rigid modules. However, the work on flexible toroids is still of interest since it is applicable to other construction associated with space stations, such as flexible connections, air locks, collapsible fuel cells, and space suits.

The torus model shown in figure 1 was constructed by using a filament cage and bladder. The model has an overall diameter of 24 feet, a cross-sectional diameter of 8 feet, and weighs only 280 pounds. The cage is designed to take the major pressure loads and is constructed of 80-mil-thick dacron cords arranged meridionally around the torus. An 8-mil-thick bladder made of butyl-impregnated nylon placed inside the cage contains the inflation gases and carries relatively small local longitudinal loads. This model has an operating pressure of 7 psi and was designed with a safety factor of 5.

The composite material has a maximum tensile strength of over 1,800 pounds per linear inch and weighs 0.25 pound per square foot. This material is foldable, as shown in figure 2. Tests have indicated that the torus can be packaged around the hub so that it occupies a volume equal to only 2 percent of its inflated volume. Repeated folding and inflation tests in air have indicated no structural damage due to the packaging, and it also has been successfully inflated in a vacuum.

A second method of structural skin construction employs a filament-winding concept. A 45-inch-outside-diameter torus constructed by using this technique was recently investigated. Multiple meridional windings and inner and outer equatorial bands to take the overall longitudinal loads were used in this construction. (See upper left-hand sketch in fig. 3.) Design burst pressure was 280 psi. The materials used were 12-mil-thick dacron cords and a polyurethane elastomer.

The resulting composite material had a maximum tensile strength of over 1,800 pounds per linear inch, or 56,000 psi based on the thickness of the material, which was only about 32 mils. It was not readily foldable, however, probably because of the small amount of elastomer contained in the composite - only about 20 percent. Pressure tests indicated a failure of the structure at approximately 40 percent of design burst pressure. The failure was not due to a breaking of the cords but occurred because of localized spreading apart of adjacent cords which were held in place only by the relatively weak elastomer. These deficiencies have been corrected in the design of another 45-inch-diameter torus which uses double-helix windings and a modified elastomer content. (See upper right-hand sketch in fig. 3.)

A third way of constructing the structural skin employs the pattern-layup method, wherein gores of a special three-ply fabric are joined together to form the torus. Each ply is constructed of a flexible elastomer and flexible cord reinforcements with all the filaments in a given ply being parallel to one another. The plies are arranged so that the cords of one are oriented meridionally on the torus, and the cords of the other two plies are oriented approximately 45° to either side of the meridional ply. (See sketches in lower part of fig. 3.) This arrangement allows the fabric to handle the approximately 2-to-1 stress ratio in the torus skin.

Samples of such composite materials have been constructed of a butyl rubber elastomer and dacron cords. One of these fabrics is 1/10 of an inch thick and weighs about 0.6 pound per square foot. It has a maximum tensile strength of 1,800 pounds per linear inch, or 18,000 psi based on the 1/10-inch thickness. The fabric is easily foldable since it contains approximately 65 percent elastomer. It may be concluded from these data that flexible fabrics having very high strength-to-weight ratios are within the present state of the art.

MATERIAL PROPERTIES

Many of the materials available for use in constructing a manned space station have been tested by the manufacturer, and the results are

L
3
1
8
6

available in current publications. The properties evaluated in these tests, however, are usually those of concern at the surface of the earth. Little information is available on properties which determine the suitability of a material for space application, such as the effects of exposure to a hard vacuum and to far ultraviolet radiation. It became apparent early in the studies, therefore, that prospective materials must be exposed to such conditions as a hard vacuum, ultraviolet radiation, and large temperature extremes for long periods of time. The degradation of properties due to this exposure could then be measured in order to determine their value for application to manned space structures. Accordingly, space-materials environmental test programs covering these variables have been initiated at the Langley Research Center.

In the investigation of the effects of the space environment on the strength of flexible fabrics, the emphasis has been on long-term tests. Some interesting results are being obtained, such as those indicated in figure 4. Samples of three different filament-elastomer composite fabrics being considered for use in space were exposed to a pressure of 4×10^{-7} mm Hg for 140 days at room temperature. Breaking tensile strength of the samples was determined before exposure and after exposures of 24, 61, and 140 days. The nylon-buna N fabric lost 5 percent of its strength the first 24 days in the vacuum and then retained an approximately constant strength for the rest of the test. However, a nylon-neoprene fabric and a dacron-silicone sample decreased in strength about 11 percent after the 140-day exposure. The important thing to note is that the decrease occurred over the whole exposure period and that there were indications that continuing small decreases might be expected upon further exposure.

Some effects of a hard vacuum on the weight loss of some prospective space-station materials are shown in figure 5. Each sample tested had about 20 square inches of surface area and weighed about 4 grams. The data were obtained at a pressure of 5×10^{-7} mm Hg and at room temperature in the vacuum system shown schematically in figure 6. This system has a balance sensitive to 1 milligram installed in the bell jar and allows continuous weighing of a sample without exposing it to the varying moisture conditions of air. Such an enclosed system has been found to be very necessary in order to obtain meaningful results.

The data presented in figure 5 indicated no serious weight losses. A dacron-polyolefin sample exposed for 14 days lost only 0.07 percent of its weight, all of this loss occurring during the first 24 hours. A dacron-butyl fabric exposed for 50 days lost 0.5 percent of its weight. This loss, however, occurred over a period of 30 days. A dacron-neoprene sample lost 2.5 percent of its weight in 21 days. Most of these weight losses were probably due to the loss of adsorbed atmospheric gases as

indicated in reference 1. These data show the desirability, as indicated also for the strength-loss tests, of making sure that such exposures are continued for sizable periods of time or until there is positive evidence that no further changes in properties are taking place. It is obvious that short-term tests, or especially the extrapolation of short-term results to obtain long-term effects, could be very misleading.

As a continuation of this test program, materials such as those just described, as well as thermal-control coatings, will also be exposed to far ultraviolet radiation and to temperature extremes from -200° F to 200° F. In another program at Langley, Mylar and polypropylene are undergoing tests in a hard vacuum with exposure to ultraviolet radiation and temperature extremes in order to determine their behavior in space. Ultraviolet radiation can have a serious effect on thermal-control coatings because color changes, usually toward the darker side, often take place. Since these effects can vary and can have an extremely serious effect on the temperature of the interior of the space station, extensive tests of the particular coatings selected for use will be required.

L
3
1
8
6

No vacuum-exposure tests on metals have been included in the program because much is already known about the behavior of metals in the space environment, whereas little is known about polymers. As indicated in reference 2, there appears to be no problem concerning the use of most of the structural metals in space. Aluminum, steel, and titanium, for example, must be exposed to temperatures above $1,200^{\circ}$ F before they will lose as much as 0.0004 inch of surface thickness per year. This loss would have no significance structurally; however, changes in the properties of surfaces could affect the absorptivity and emissivity of the material and upset the thermal balance of the space station. Also, there is little evidence that the elements of the space environment being considered have any appreciable effect on the other mechanical properties of structural metals.

In addition to the previously discussed effects of ultraviolet radiation and a hard vacuum on the surface of the space station, long-term sputtering must be considered. Information available at the present time indicates that the effects of low-energy solar protons may be negligible. However, sputtering caused by atmospheric particles may be serious and depends on the surface material and altitude (ref. 3). For example, at an altitude of approximately 300 nautical miles, 1,250 angstroms per year would be removed from an aluminum surface, whereas the loss from a silver surface would be negligible. It is also indicated that sputtering caused by micrometeorites is of the same order of magnitude as that caused by the earth's atmosphere at this altitude (ref. 4).

AIR-LEAKAGE PROBLEM

It is of vital importance that a space station retain as much as possible of its initial supply of air. Provisions for extensive resupply are very costly from a launch weight standpoint. As a result, air leakage, whether by permeability through the wall material or through joints, seams, and various seals, must be kept to an absolute minimum.

L
3
1
8
6
The 150-foot-diameter space-station configuration described in paper no. 2 contains several air-leakage problem areas. These areas are indicated in figure 7. They include about 20,000 square feet of surface area, riveted or welded joints, sliding seals, 90° rotating seals, permanent seals between the modules, reusable seals for docking, and rotating bearings and seals for intermittent use between the docking rig and the hub of the torus. A research effort is underway in some of these areas and some results are available.

By using a gas-transmission tester, several wall materials have been tested for leakage rates with a pressure difference of 15 psi across the sample. This tester is of the Dow-cell type and will measure gas-transmission rates at standard conditions as low as 0.001 cubic foot per year per square foot of surface area. The results are presented in table I. Sheet materials tested are listed in the left-hand block and joints are listed in the right-hand block. All items above the central horizontal line had negligible leak rates; those below the line had high leak rates. A negligible leak rate, based on the 150-foot-diameter space-station surface area, was considered to be less than 2 pounds of air per year.

As noted in table I, no measurable loss occurred through 1/64-inch-thick 2024, 6061, or 2014-T6 aluminum or type 347 stainless-steel sheets. Also, no loss occurred through straight or curved heliarc welds or straight resistance welds in aluminum. Curved resistance welds in the same material, however, had a high percentage of rejects. Riveted joints leak badly and methods of sealing these joints using saran and other sealants are being investigated. Fabrics have generally unacceptably high leak rates, but the leakage can be made negligible by applying a 1-mil coating of saran.

In order to have various nonrotating outside attachments to a rotating space station such as that shown in figure 7, it would be convenient to have the bearings operate in a hard vacuum. Some encouraging results of tests on such bearings are available. The Arnold Engineering Co. has tested composite bearings of a fiber-glass-reinforced Teflon impregnated with molybdenum disulfide at a pressure of 3×10^{-7} mm Hg at 1,500 rpm. The bearings were operated for 100 hours at a radial load

of 75 pounds. Neither starting friction nor running friction was appreciably different from that for the same bearing operating at atmospheric pressure. Hughes Aircraft Co. has also tested Teflon bearings at a pressure of 8×10^{-9} mm Hg before and after being irradiated with a cobalt 60 source for 4 days. Again changes in friction were negligible.

It may also be desirable to have a seal between a rotating and non-rotating part of the station. Early data indicated that high friction coefficients might make such rotating seals impractical. However, recent data from the International Latex Corp. obtained on a rotating seal approximately 1 foot in diameter indicate that a seal of Teflon against anodized aluminum has very low friction. These data, scaled to a 6-foot-diameter seal turning at 4 rpm, indicate that only 1/10 horsepower would be required to drive it, and the air-leakage rate at a 10-psi pressure differential would be 1/2 cubic foot per hour. This leakage rate is not excessive when it is realized that such rotating seals would be in use for only short periods of time during docking operations. Langley is presently building a 3-foot-diameter rotating-seal tester to continue this research.

L
3
1
8
6

CONCLUDING REMARKS

The work on materials and fabrication methods for manned orbiting space stations has only begun. Honeycomb structures, lubricants, and rigid and flexible foams must be studied, and the effort on sealing methods must be intensified. In addition, more information must be obtained on surface sputtering by the earth's atmosphere and on the effects of the space environment, especially particle and electromagnetic radiation, on prospective space-station materials and built-up flexible and rigid-wall sections.

REFERENCES

1. Caruso, S. V., and Looney, W. C.: A Study of the Outgassing and Evaporation Products of Some Materials Upon Exposure to Reduced Pressure. MTP-P&VE-M-62-7, NASA George C. Marshall Space Flight Center, 1962.
2. Jaffe, Leonard D., and Rittenhouse, John B.: Behavior of Materials in Space Environments. ARS Jour., vol. 32, no. 3, Mar. 1962, pp. 320-346.
3. Redus, Jerome R.: Sputtering of a Vehicle's Surface in a Space Environment. NASA TN D-1113, 1962.
4. Martin, Henry L.: Micrometeorite Distribution Near the Earth. MTP-M-RP-61-2, NASA George C. Marshall Space Flight Center, 1961.

L
3
1
8
6

TABLE I
SUMMARY OF AIR-LEAKAGE TESTS

LEAK RATE	SHEETS	JOINTS
NEGLIGIBLE	1/64 IN. 2014-T6 AL 1/64 IN. 2024 AL 1/64 IN. 6061 AL 1/64 IN. 347 ST. STEEL FABRICS WITH 1-MIL SARAN	STRAIGHT HELIARC WELDS IN AL CURVED HELIARC WELDS IN AL STRAIGHT RESISTANCE WELDS IN AL
HIGH	1/10 IN. ELASTOMER-CORD FABRICS	CURVED RESISTANCE WELDS IN AL RIVETED JOINTS IN AL

24-FOOT-DIAMETER ERECTABLE TORUS INFLATED TO 7 PSI

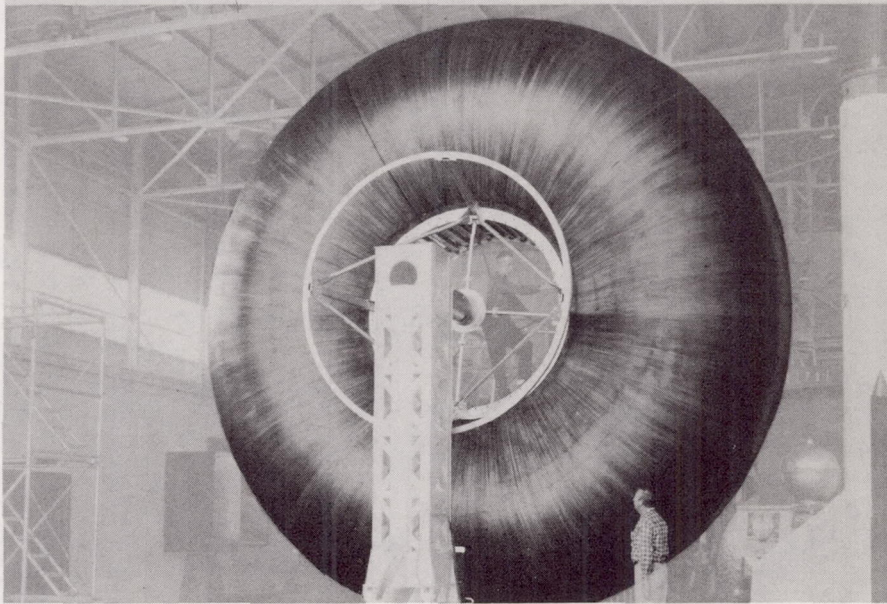

Figure 1

L-62-1021

24-FOOT-DIAMETER ERECTABLE TORUS FOLDED
AROUND RIGID HUB

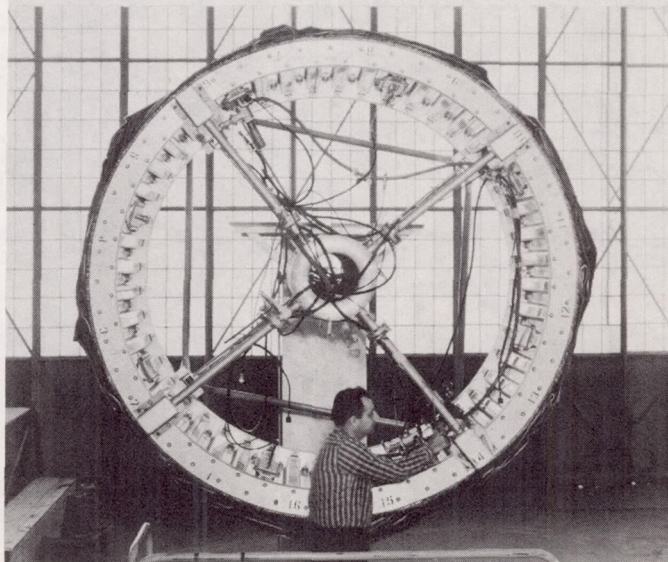

Figure 2

L-62-447.1

ERECTABLE-TORUS FABRICATION METHODS

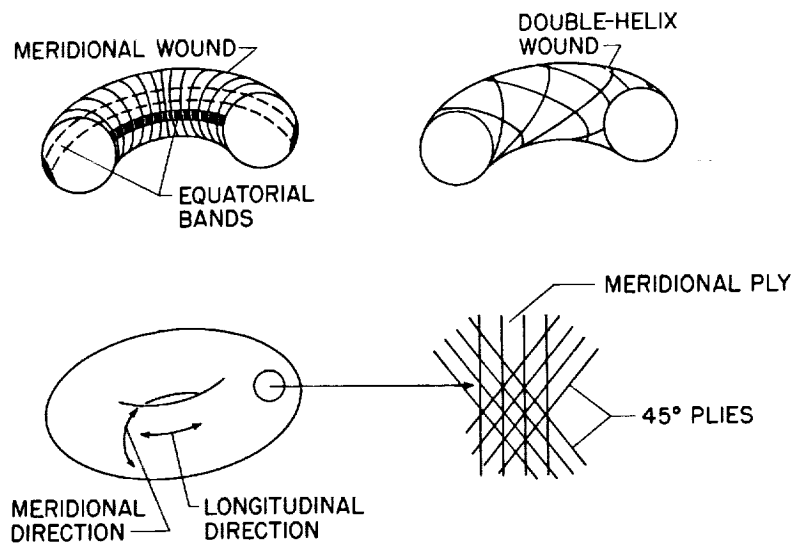

Figure 3

EFFECTS OF VACUUM ON STRENGTH OF FLEXIBLE FABRICS

 $p = 4 \times 10^{-7}$ mm Hg

Figure 4

EFFECTS OF VACUUM ON WEIGHT LOSS OF FLEXIBLE FABRICS

 $p = 5 \times 10^{-7}$ mm Hg

Figure 5

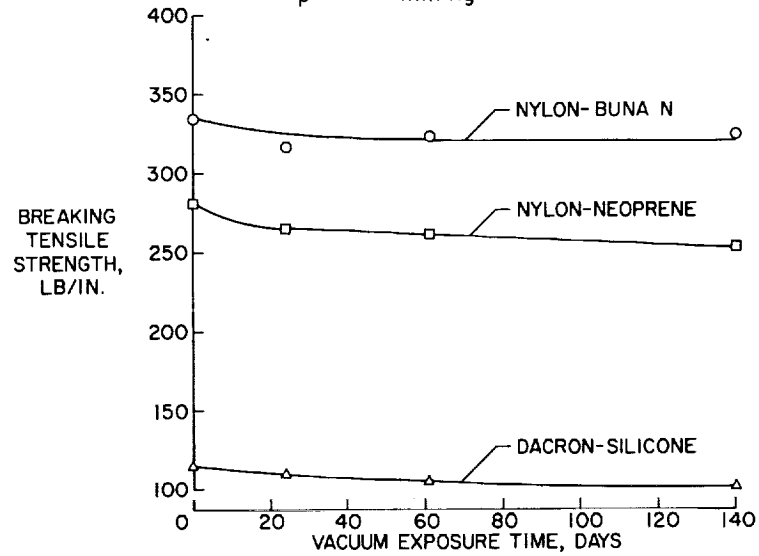
AUTOMATIC VACUUM BALANCE

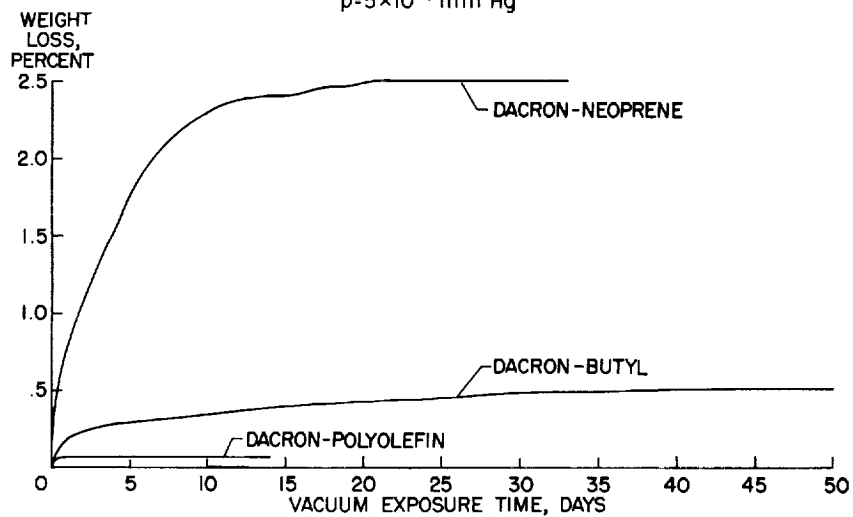
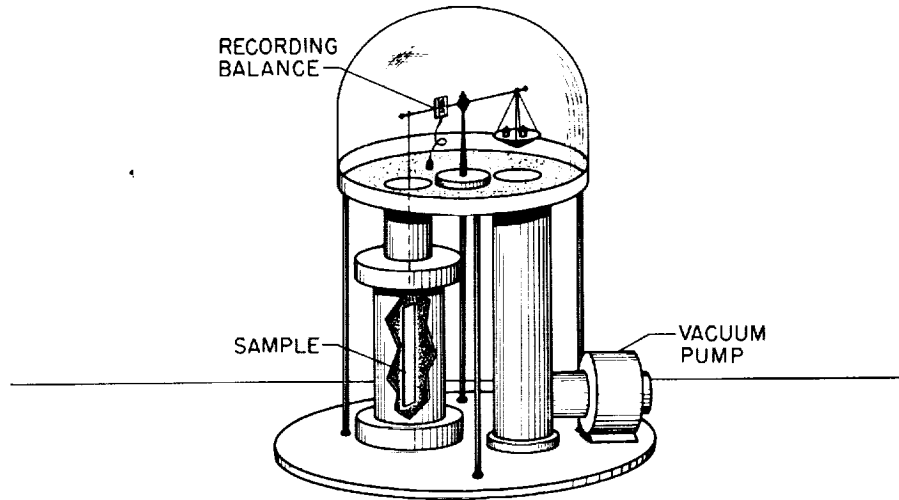

Figure 6

AIR-LEAKAGE PROBLEM AREAS

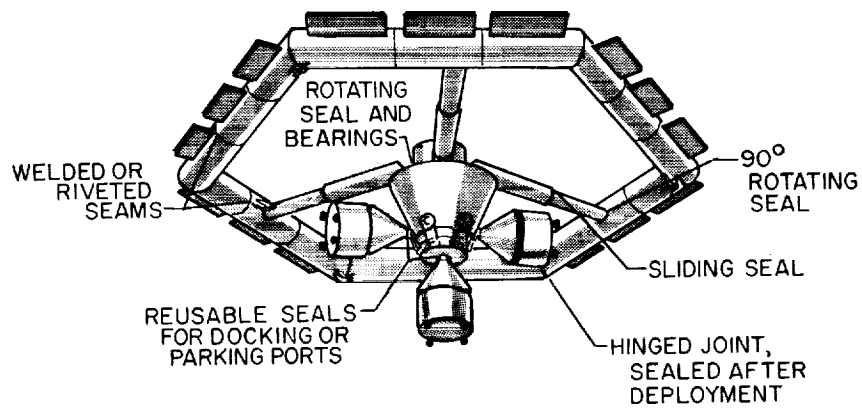

Figure 7

6. SPACE-STATION POWER SYSTEMS

By John R. Dawson and Atwood R. Heath, Jr.

SUMMARY

Power requirements for various functions of a manned space station are discussed with particular reference to the study by North American Aviation, Inc. Applicable sources of energy and methods of converting these sources to electricity are reviewed. The National Aeronautics and Space Administration, United States Air Force, and Atomic Energy Commission programs for development of power systems are of interest here. Some significant aspects of solar power systems that might be used are indicated. The power system proposed by North American Aviation, Inc. (solar cells and batteries) is outlined and it is found that this system is representative of the current state of the art for solar systems.

INTRODUCTION

Power is required for a variety of purposes in a manned space station, but accurate determination of the amount needed depends on the development of each source of demand to a fairly advanced state. Consequently, estimates of the power requirements are currently very approximate. Some of the significant power needs and various aspects of power systems that might be used to supply these needs are discussed in this paper. Particular attention will be given to the studies made by North American Aviation, Inc., and to its proposed power system.

DISCUSSION

Power Required

Some of the functions requiring a substantial amount of power are listed in three groups:

- (1) Those dependent on station size
 - Environmental control and lighting
 - Stabilization and control
- (2) Those dependent on personnel aboard
 - Environmental control and lighting
 - Food preparation

(3) Those independent of station size or number of personnel
 Communications
 Experiments

It is evident that some needs depend on more than one thing, notably, the environmental control. Included in the third group are communications, which require a fixed amount of power almost regardless of station size or the number of occupants, and experiments, which depend entirely on their nature for power requirements.

Studies of power requirements have been made in connection with an Air Force space-station project and in connection with a study by North American Aviation, Inc. (NAA) of a 38-man station, 150 feet in diameter. The NAA power analysis is summarized as follows (the numbers have been rounded to hundreds for simplicity):

	Watts
Average:	
Environmental control and lighting	7,200
Stabilization and control	400
Food preparation	200
Communications	800
Experiments	2,400
Total	<u>11,000</u>
Peak	20,000

These values do not include allowances for a regenerative oxygen supply. NAA estimates an additional power of 12,000 watts for a regenerative supply of oxygen when electrolysis is used.

Even without regeneration, the dominant requirement for power is the environmental control system; with regeneration, this requirement dwarfs all other power needs. Inasmuch as the dominant power need depends on both station size and number of persons aboard, both should be taken into account, even in rough estimates of power requirements.

Power Generation

A power system with a capability of about 20 to 30 kilowatts is assumed in this discussion. Types of power systems that might be used are shown in table I. Combinations most likely to provide a power system suitable for a large manned space station are indicated by the shaded area, and combinations considered in the NAA study are denoted by check marks. There is only one source of energy existing in space that is readily available - the sun. If a source of energy that will last for a year is to be carried into space, some form of nuclear power

system, reactor or radioisotope, must be considered. Conceivably, the fuel could be carried to the space station in ferries, and thus a chemical source might be used. However, it is almost axiomatic that a system which is capable of lasting for the lifetime of the station is the desired type, and only solar and nuclear systems are given much consideration for a lifetime of one year.

A number of methods are available for converting the basic source of energy to electricity. Solar cells that provide photovoltaic conversion would be used only with the solar energy source. Thermocouples (giving thermoelectric conversion) or thermionic conversion can both be used with either nuclear or solar sources. Fluid/mechanical conversion is a dynamic system operating a heat engine through a working fluid; it is usable with any source that produces heat, but it is most adaptable to solar and nuclear reactor sources.

Regenerative fuel cells can theoretically be used with any source of heat. Although open-cycle fuel cells are undergoing considerable development and their use in the next few years may be anticipated, the regenerative fuel cell is far from a practical accomplishment, and its place in future power systems is not yet established sufficiently to permit judgment of its usefulness.

Power Development

Table II shows solar-power-development programs that are of interest. The current state of the art is represented by one conversion method; that is, of course, the solar-cell system. A considerable number of small systems have already operated successfully, but solar-cell systems up to about 500-watt capacity are now being designed for space projects. Advancement in solar-cell technology is being continued by development of improved components.

There are two thermal-type solar systems under some development by NASA. One is the Sunflower project which is a 3-kilowatt fluid/mechanical system. Recent decisions indicate that this project will not continue as the development of a complete system but will, instead, be limited to the development of components and advancement of technology. It may, therefore, not be available as a complete power system. The status of the solar energy thermionic (SET) conversion system under development at Jet Propulsion Laboratory for use in planetary missions is not very different. It is being developed as a backup for a solar-cell system and it will be of interest for planetary missions if it can be developed by 1964. The SET system will produce 500 watts in an orbit about Mars or 1,150 watts in an orbit about Earth.

The Air Force has programs on a 15-kilowatt fluid/mechanical system, a small solar thermionic electrical power system (Steps), and a 1.5 kilowatt thermocouple system. However, all these programs are at present directed towards advance technology rather than complete system development.

Table III shows nuclear power systems that are being developed as complete working systems. Their status is more definite than that of the solar power systems. Snap-8 is of greatest interest and it should be available about 1965; Snap-2 and Snap-10A are smaller than Snap-8 and should be available about the same time. Depending on the solution to flight operating and shielding problems, these nuclear-reactor power supplies could presumably be used on a manned space station in the late 1960's.

The Snap programs designated with odd numbers are for systems using radioisotopes. The power levels are so small, however, that it would take many of them to furnish all the power needed for a manned space station and they are given only slight consideration in view of the probable availability of larger units of the reactor type.

Efficient use of nuclear power systems on manned space vehicles calls for shadow shielding, in which the reactor is placed behind a nearly flat shield, rather than cell shielding, in which the reactor is completely surrounded by shielding. It is a moot question whether shadow shielding, even in the vacuum of space, will be practical with a vehicle that will have manned ferries coming and going.

Power Storage

In any solar power system for earth orbit there must be provision for storage of power to be used in the period when the sun is not visible. For this power-storage system, a circular orbit of 300 nautical miles that is nearly equatorial is assumed. This orbit will result in about 36 minutes in darkness and 64 minutes in sunshine. During the period of sunshine, there must be sufficient power stored to take care of the power needs in the dark period. Thermal, chemical, or battery storage may logically be considered. Thermal storage is most adaptable to the fluid/mechanical power system and cannot be used efficiently with solar cells. Chemical storage, that is, the regenerative fuel cell, may in theory be used, but in its present early development stage it has not progressed to the point where it can be given serious consideration. Batteries are, of course, suitable for power storage in any system generating electrical energy and they are well established as power supplies in satellites. Their life depends on the depth of discharge being sufficiently low to allow a satisfactory number of charge-discharge cycles. The sealed nickel-cadmium battery is practically standard for satellites

today. The chief objection to batteries as a storage system is their relatively high weight.

Solar Power Systems

One of the more important characteristics of solar power systems is the weight, and in figure 1 estimates of the specific weight of four conversion systems are shown. Weight estimation is not very exact when systems have not yet been developed, but the values in figure 1 give some idea of what may be expected in the future if developments are successful. The shorter bars indicate weights for operation in continuous sunlight with a constant power demand. The longer bars give values for an orbit that is dark for about one-third of the time; they include the weight of the power-storage system plus the weight required for additional energy collection to charge the storage system during the sunlight period.

The estimates here are based on the use of batteries for power storage with the thermocouple and solar-cell systems. Thermal storage is assumed for the fluid/mechanical and thermionic systems. It is evident that the principal weight differences are due to the differences in the storage system, a much lower specific weight being indicated for thermal storage than for batteries. The thermionic system is shown here as the lightest, but considerable development of converter units is required to obtain an efficient long-life system.

The improvement in efficiency that is expected with more advanced types of solar systems will impose some restrictions on operation as indicated in figure 2. The percent of maximum power (power obtained with orientation directly towards the sun) is plotted against misalignment angle. This effect is dependent on a number of factors, but the curves shown give an approximate indication of the effect for each system represented. As would be expected, there is a rough correlation between the operating temperature and the precision of orientation required, the highest temperature systems requiring the most accurate orientation. The least effect is noted for the conventional flat panels of solar cells; the deviation is approximately a cosine curve. When concentrators are used to reduce the number of solar cells, the effect is larger. The cross-hatched band indicates the region applicable to the three thermal systems. Thermionic systems are very critical; power can be reduced to zero when misalignment is as little as 0.5° and design operation calls for pointing within a few minutes of angle.

The solar collector is a critical component of some solar power systems. Types of collector construction are illustrated in figure 3. The Fresnel reflector has a flat foldable structure with concentric reflecting serrations. The rest of the collectors are paraboloids. The inflatable type shown has a transparent cover. The one-piece collector is limited in size by the diameter of the launch vehicle; if used in large-capacity

power systems, there would have to be a number of collector units. The petal type has petals that unfold, and the umbrella type has ribs with a stretched membrane covering them.

In figure 4 performance data for representative collectors of the types illustrated are given. Specific power in watts per pound available to the heat absorber is plotted against absorber temperature. The lightest types are the umbrella and inflatable collectors, but these are not as accurate as some of the heavier types. The umbrella type can be used only with low-temperature cycles. The inflatable type, though capable of high temperatures, would be punctured by meteoroids and deflated; therefore, its life would presumably be very short. Various methods of rigidization of inflatable collectors to make them more lasting are under development. The petal type is being considered primarily for fluid/mechanical conversion systems. The heavy one-piece collector is very accurate and capable of achieving very high temperatures. This Fresnel-type collector has a low specific power at high temperatures although higher performance than shown is apparently obtainable. This Fresnel collector is scheduled for a 1962 flight in the Air Force project Eros (experimental reflector orbital shot). It will be launched into a low polar orbit for the study of flight deployment, retention of shape, and thermal gradients under space environment for a relatively short life.

L
3
1
8
6

Since no solar collector has yet been put into space, the practical operating lifetime of solar collectors in space is undetermined. The question of most concern is whether specular reflectivity will be maintained to an adequate degree under space environmental conditions, particularly the meteoroid and radiation environments. Low-energy protons can cause sputtering, and it is this part of the radiation spectrum that is of most concern regarding the reflector surface.

Silicon solar cells on the other hand have been used in numerous space-flight applications and have proved their ability to provide power for long periods. However, they are subject to corpuscular-radiation damage and there is evidence of deterioration due to space radiations even in the case of Vanguard I, although transmissions have continued for years at reduced power.

NAA Power System

The significant features of the power system proposed by NAA are as follows:

Power generation:

Number of solar-cell panels	7
Total area, sq ft	2,325
Peak power, kw	24
Average power, kw	11
Weight, lb	2,558

Power storage:

Nickel-cadmium batteries, kw-hr	25
Weight, lb	2,572

Power control:

dc to ac	Static system using semiconductors
Voltage regulation	Static system using semiconductors
Weight, lb	315

The system is decentralized and consists of seven flat panels of silicon cells, one for each station module and one for the hub of the space station. Alternating-current power requirements are met with static inverters fed by the generated direct-current supply. Similarly, when an accurately regulated direct-current supply is needed, static voltage regulators depending on semiconductor devices are provided. The weight of the inverter and regulator systems is small.

Although this power system is larger than existing systems, it is substantially based on present state of the art in spacecraft power systems. At the orbit specified, radiation damage to conventional solar cells should be insignificant. There are sufficient cases of satellites whose battery life has been close to the predicted lifetime to justify confidence in the prediction of the performance of the nickel-cadmium batteries. Semiconductor technology should not be strained to provide the power regulation and conversion necessary.

The weight estimates are conservative in comparison with similar estimates made independently by others and it is not unreasonable to expect that a solar-cell system of somewhat lighter weight may be obtainable in 1965. This power supply is really seven independent power systems and the reliability provided by that redundancy, backed by the extensive successful flight experience with solar-cell systems, should be very high.

CONCLUDING REMARKS

If a space-station power system with advantages beyond those obtainable from solar cells and batteries is desired, a choice must be made between the use of solar and nuclear energy sources. If an advanced solar system is selected, the development of the actual power system will in all probability have to be undertaken as part of the space-station development because present power-development programs are not intended to provide complete systems suitable for space flight.

The nuclear power program is providing developed systems having capacities of interest for space stations, and these systems should be available in the late 1960's. However, the problems of operating and shielding in the presence of nuclear radiations will require solution as a part of the integrated space-station development.

TABLE I
POWER SYSTEMS

CONVERSION	SOURCE			
	SOLAR	NUCLEAR		CHEMICAL
		REACTOR	RADIOISOTOPE	
SOLAR CELL	✓			
THERMOCOUPLE	✓	✓	✓	
THERMIONIC	✓	✓	✓	
FLUID/MECHANICAL	✓	✓		✓
FUEL CELL	✓	✓	✓	✓
✓ CONSIDERED BY NAA				

TABLE II

SOLAR POWER DEVELOPMENT

AGENCY	TITLE	TYPE	POWER, KW	STATUS
—	—	SOLAR CELL	< .5	STATE OF ART
NASA	SUNFLOWER	FLUID/MECHANICAL	3	TECHNOLOGY ONLY
NASA	SET	THERMIONIC	1.15	1964 (?)
USAF	—	FLUID/MECHANICAL	15	TECHNOLOGY ONLY
USAF	STEPS	THERMIONIC	—	TECHNOLOGY ONLY
USAF	—	THERMOCOUPLE	1.5	TECHNOLOGY ONLY

TABLE III

NUCLEAR POWER DEVELOPMENT

AGENCY	TITLE	TYPE	POWER	STATUS
USAF/AEC	SNAP-2	REACTOR FLUID/MECHANICAL	3 KW	---
NASA/AEC	SNAP-8	REACTOR FLUID/MECHANICAL	30-60 KW	1965
USAF/AEC	SNAP-10A	REACTOR FLUID/MECHANICAL	500 W	---
USAF/AEC	SNAP - ODD NUMBERS	RADIOISOTOPE THERMOCOUPLE	<125 W	VARIABLE

SOLAR POWER SYSTEMS

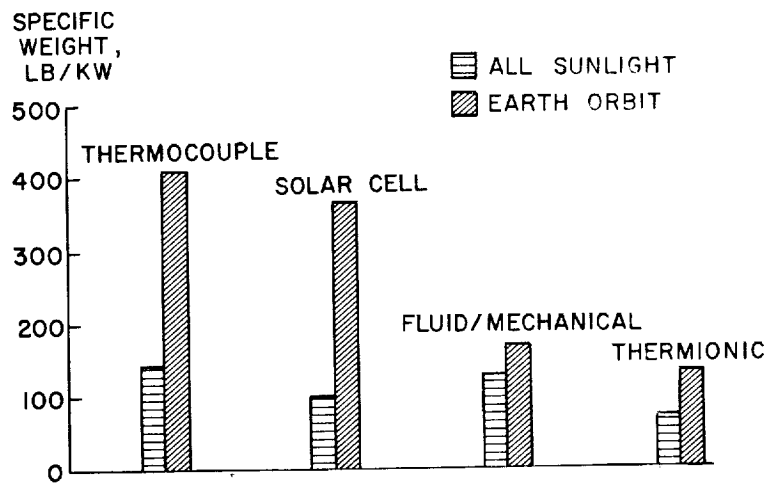

Figure 1

EFFECT OF MISALINEMENT

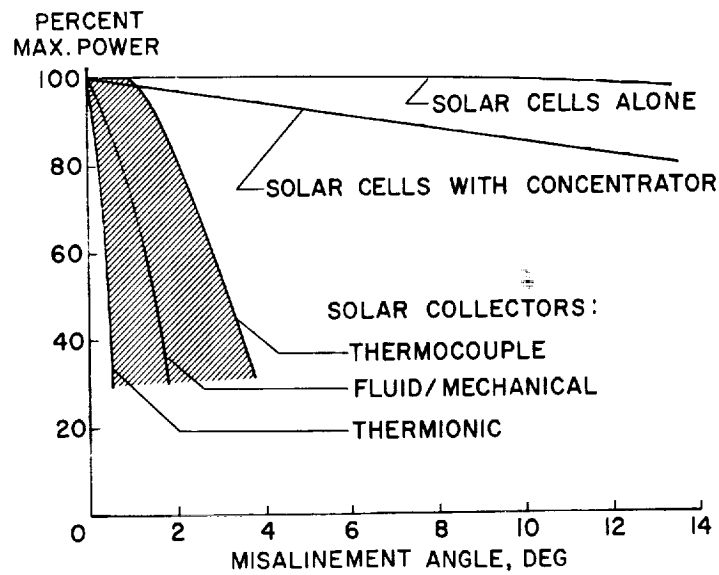

Figure 2

SOLAR COLLECTOR TYPES

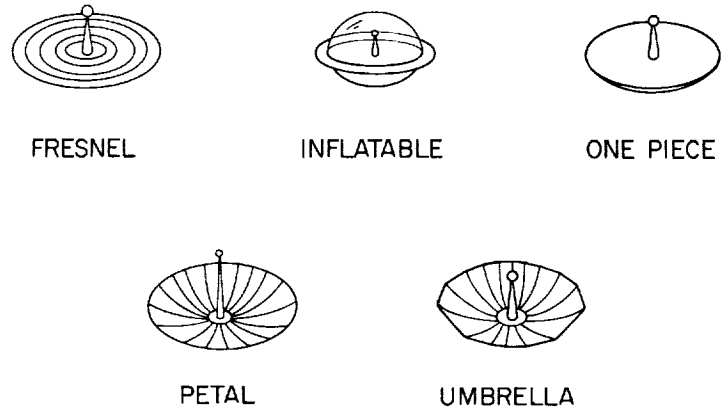

Figure 3

SOLAR COLLECTOR CHARACTERISTICS

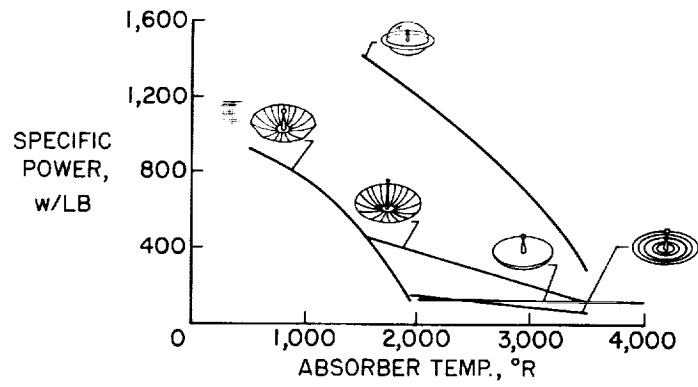

Figure 4

7. SPACE-STATION DYNAMICS AND CONTROL

By Peter R. Kurzhals, James J. Adams,
and Ward F. Hodge

SUMMARY

L
3
1
8
6
The problems associated with the dynamics, stabilization, and attitude control of manned rotating space stations are discussed, and the basic study areas in these fields are outlined. Experimental station dynamic models and testing procedures are described, and the station wobble resulting from applied disturbances, such as dynamic unbalances created by crew motions and impulsive torques produced by docking maneuvers, is illustrated. Characteristic theoretical and experimental results are presented for both a 30-foot inflatable station and a 150-foot rigid modular self-erecting station.

The functions of the station stability and attitude control systems are defined, and three systems under study at the Langley Research Center are considered. These systems are a pulse-jet system capable of both attitude control and wobble damping, a wobble damper utilizing a constant rate flywheel, and a permanent magnet system producing a precession torque by interaction with the earth's magnetic field. Typical calculated and experimental data for the station motion with these systems are included, and preliminary weight estimates for these systems and the 150-foot station are given.

INTRODUCTION

The advantages of artificial gravity in a manned space station in general dictate the need for rotation to provide this gravity. If the axis of rotation is one of maximum moment of inertia, this rotation also provides spin stabilization and a tendency toward maintenance of the station orientation in space. The station thus acts much as a gyroscope and resists applied torques and disturbances.

There are, however, other problems characteristic of the dynamics of spinning bodies. These problems originate from the wobbling motions and elastic oscillations produced by imposed disturbances, such as dynamic unbalances created by crew motions and impulsive torques resulting from docking impacts. (See refs. 1 to 3.) The undamped station

wobbling motions produced by such disturbances are undesirable and may lead to further difficulties. There is, for example, a possibility that the station wobbling may cause nausea and disorientation of the crew. The elastic response of the station may further complicate this problem by producing excessive cyclic loadings and by interfering with the station control.

In short, two principal tasks are imposed in this field of space station research: the first task is to determine and define the attitude errors and wobbling motions resulting from the applied disturbances by both experimental and theoretical means, and the second is to devise and test the damping and attitude-control systems capable of minimizing any undesirable station motion while maintaining the required station orientation in space.

DYNAMICS OF SPACE STATION

The task of determining the attitude errors and wobbling motions requires an investigation of the dynamics of the spinning station. This investigation has been initiated by experimental tests of dynamically scaled models in a simulated space-support environment. One of these models is shown in figure 1. The 10-foot-diameter model represents an inflatable 30-foot-diameter space station consisting of a rigid central module and an inflatable outer torus connected to this module by four spokes. The effects of crew motion and cargo transfer within the station are simulated by an electrically driven mass moving on a track. This mass can be moved at different programmed velocities, corresponding to walking or running rates of the crew. An automatic center-of-gravity device, which constantly aligns the center of rotation with the center of gravity, is employed to compensate for the gravity moments exerted by the mass movements. Docking torques and attitude-system moments are simulated by pulse jets on the torus.

For a test the model is brought to the desired spin speed by spin-up jets. The disturbance is then applied and the resulting station wobbling motion is measured and recorded by solar cells and a fixed light source above the model. The angular velocities and accelerations about the body axes are also recorded, and both the rigid-body response and the elastic motions of the model are defined.

As an illustration of the wobbling motions produced by a typical disturbance, the computed station response for a crew shift is presented in figure 2. The disturbance shown is the dynamic unbalance produced by the movement of one of the crew members from the plane of the center of gravity to a point 2 feet out of this plane. The station, which initially spins smoothly about its Z-axis at 10 rpm, then undergoes a

wobbling motion as shown on the right of this figure. This wobbling is illustrated both as the attitude of the station with respect to a space-fixed coordinate system and as the angular rate about the X- and Y-axes measured with respect to the rotating-body-axis system. The fixed-space attitudes, which are given by the angles made by the X- and Y-axes with respect to the initial XY plane, show an irregular oscillation with a maximum amplitude of 4° . The station angular rates with respect to the body axes also oscillate. Since this rate oscillation produces a continuous rolling of the centrifugal force or effective gravity vector, the wobbling appears as a continuous motion of the station floor. Basically, this motion is similar to the rolling motion of a moving ship.

It is of interest to consider the effect of the station inertia distribution on the maximum wobble angle produced by a given crew shift. This problem, which was briefly discussed in papers no. 1 and no. 2, is illustrated in figure 3. This figure shows a plot of the maximum wobble angle α , referred to the wobble angle of the disk or torus configuration α_{DISK} , as a function of the station inertia ratio I_X/I_Z .

The solid line represents the theoretical results calculated on an IBM 7090 computer and the square symbols correspond to experimental data. The maximum wobble angle is shown to increase rapidly as the inertia ratio goes from 0.5, the disk value, to 1.0, the value for a spherical station. A further increase in inertia ratio to a rod or cylinder again reduces the wobble angle. It must be remembered, however, that a station spinning about a minimum axis of inertia can readily precess to spinning about its maximum axis of inertia in an elastic system. Such a configuration may thus not be desirable. Based on these results, the ideal space-station configuration appears to be one with an inertia distribution that approaches that of a flat disk or torus.

Because the station wobble is noted to produce both attitude errors and apparent rolling motions resulting from the oscillation of the body rates, consideration is next given to the effects of various disturbances, as shown in figure 4. Listed are the maximum wobble angles and apparent rolling motions for two possible configurations, as determined by computer solutions. The first configuration is the 30-foot inflatable station with a rigid central module and an assumed crew of two astronauts. The second configuration is a rigid modular self-erecting space station with a maximum diameter of 150 feet and an assumed crew of 21 astronauts. The disturbance effects for these configurations and a range of disturbances are shown in tabular form. The wobbling motion was computed by lumping the crew as one mass and moving this mass to extreme positions - that is, positions farthest away from the center-of-gravity plane - at various rates of motion corresponding to crawling, walking, and running. For radial crew motions (or out-of-plane motions from the center of the station to the outside of the station) maximum wobble angles of 9° and

an apparent station rolling of 0 to 12° were produced for the 30-foot station, as compared with a wobble angle of 0.7° and rolling of 0 to 0.8° for the 150-foot station. Transverse motions (or crew motions parallel to the spin axis) and circumferential motions (or out-of-plane crew motions around the rim of the station) also produce considerably smaller wobble angles for the 150-foot station than for the 30-foot station. The extremely large wobble angles of 108° produced for the 30-foot configuration may make this type of small station unsuitable for an actual orbital mission.

For the disturbances resulting from docking impacts the 150-foot station again exhibits considerably smaller wobbling motions than the 30-foot station. In all these cases, then, the uncontrolled wobble for the 150-foot station is quite small, so that the station is relatively stable - even without a stability system.

L
3
1
8
6

The theoretical studies of the rigid-body dynamics of both these configurations have been completed. Available results from recent experimental tests of the 30-foot-station model compare favorably with the theoretical analysis, but further results that include data for the 150-foot station will be necessary before optimum configurations can be established for manned space stations.

STABILIZATION AND ATTITUDE CONTROL

Concurrently with the dynamics investigation of manned space stations, work on a second task, the development of the stability and attitude control systems required by these stations, has been started. These systems must be capable of performing three basic functions: first, control of the orientation of the station to within a desired attitude error; second, minimization of any station wobble; and third, precession of the station to compensate for the daily orbital precession of approximately 1° and for gravity precession torques.

The first of these functions, that of the station attitude control, has been investigated at the Langley Research Center, and a reaction jet system, which offers a simple and reliable means of maintaining the station orientation, has been developed. This system consists of four pulse jets mounted at the outside rim of the station and spaced 90° apart. The jets are actuated by rate and attitude data and can function both for attitude control and wobble damping. This type of system can thus serve as a backup in case of failure of the primary damper.

The efficiency of the jet system in performing these tasks has been investigated theoretically, and characteristic results are presented in

figure 5. This figure illustrates the motion of the jet-controlled 150-foot station with an initial attitude error of 10° . The station motion is shown as the trace of the Z-axis in fixed space. It can be seen that the station precesses smoothly to its final position and ends up in essentially a steady spin about this new axis in space. With a thrust level of 10 pounds for each of the four jets, approximately 160 seconds are required to turn the station through the 10° angle. The final attitude is achieved with an accuracy of $\pm 0.25^\circ$, which should be satisfactory for most space missions.

L An experimental model of this jet orientation and damping system
3 will be required to define the system response and to substantiate the
1 theoretical results.
8
6

The jet system, which requires fuel and a corresponding expulsion of mass from the station, is inefficient in damping the wobble resulting from continuous disturbances, such as crew motions. Thus a second system, a primary wobble damper, which uses electrical energy derived from sun power, was considered and tested (ref. 4). A schematic of this system is presented in figure 6. The wobble damper consists of a spinning flywheel which can be precessed to provide reaction torques that oppose the moments exerted on the station by an applied disturbance. When no damping torque is required, the flywheel, which is mounted in a double gimbal, is aligned with the spin vector of the station. When a damping torque is required about a particular body axis of the station, the flywheel is rotated so as to produce wheel angular momentum components that are perpendicular both to the spin vector and the body axis for which the torque is required. This wheel position produces the desired precession torque. If the gimbal angles are commanded to values proportional to the angular rates about the body axes, the wobble damping is automatically accomplished. The system then provides both the damping torques for the wobble and the torque necessary to keep the station spinning on a designated body axis for a dynamic unbalance, such as might be created by crew motions. This type of wobble-damping system would weigh about 2,000 pounds for the 150-foot station.

Both experimental and analytical studies have been made for the precession wobble damper. Typical results for the toroidal configuration are shown in figure 7. These wobble-damper results correspond to data obtained with a station inertia simulator, a wheel with an angular momentum of $1/34$ th that of the simulator and an out-of-plane simulated crew shift. The uncontrolled motion as shown at left is similar to the results presented previously. With the wheel actuated and a control

gain of $1 \frac{\text{deg}}{\text{deg/sec}}$, the wobble is damped rapidly to a steady cone type of

motion in which the Z-axis traces out a circle. For this coning the angular rates become constant and the attitude angles are sinusoidal.

Increasing the gain of the gimbal control system results in a further decrease of the coning motion. The effect of the damped wobble on the crew is thus limited to a small tilt of the centrifugal force or effective gravity vector. A crew member would correspondingly feel as though the floor of the station were tilted slightly.

The effect of the station inertia distribution on the damping with the flywheel system is also of interest. These results are shown in figure 8. The period of the damped oscillation is illustrated at the top of the figure and good agreement can be seen to exist between the experimental data and the theoretical calculations. The time to damp to half amplitude $t_{1/2}$, shown at the bottom of the figure, again indicates good agreement between theory and experiment. An interesting trend may be observed in this figure, namely, that for equal spin momenta, wheel sizes, and disturbance, the time to damp to half amplitude increases as the inertia ratio increases. Because of the desirability of damping the wobble as quickly as possible, a space station with an inertia ratio approaching that of a flat disk appears preferable.

In addition to the attitude control and wobble damping, a third area is being studied. This area is concerned with the slow precession of the station to compensate for the daily orbital precession of 1° . Both a jet-reaction system and a magnetic system have been considered for this precession. The jet system consists of two small jets on the rim of the station, which fire one burst per revolution. A system of this type would require about 1,900 pounds of fuel per year for the 150-foot station.

In comparison, a magnetic system similar to that described in reference 5 is shown in figure 9. This system consists of a permanent dipole magnet of strength \bar{M}_S aligned with the station spin axis. The station and this magnet move through the earth's magnetic field, represented by a dipole magnet of strength \bar{M}_E . The earth's magnetic-field intensity \bar{B} can then be written as a function of \bar{M}_E and the position coordinates λ and \bar{r} for the space station. If a coordinate system ζ , ξ , and η is taken with the ζ -axis along the station spin axis and $\zeta\xi$ -plane parallel to the ecliptic plane, the interaction of the earth's magnetic field components \bar{B}_ζ , \bar{B}_ξ , and \bar{B}_η with the permanent magnet \bar{M}_S in the station then produces torque components along the ξ - and η -axes. As the earth and the station with it move around the sun, it would be desirable to rotate the station Z-axis so as to keep it aligned with the sun. The precession torque $T_{\text{PRECESSION}}$ about the ξ -axis would accomplish this objective, if the average out-of-plane torque $T_{\text{OUT OF PLANE}}$ over the station lifetime goes to zero. A digital computer

solution for these torques has been developed and typical results for the 150-foot station are shown in figure 10.

The orbit-averaged precession and out-of-plane torques, given by the solid and broken line, respectively, show that the precession torque when averaged over 1 day gives a positive value. The out-of-plane torque, when averaged, is close to zero so that the magnetic system would tend to produce essentially the true desired precession. If this behavior holds over the entire station lifetime, a magnetic-precession system appears feasible. This system would offer an appreciable weight saving over a jet system. For example, the magnet required to precess the 150-foot station would weigh about 1,000 pounds or about half as much as the jet system.

As part of a feasibility study on manned space stations, North American Aviation, Inc. has developed linearized analytical solutions for the station motions with and without flywheel and jet stability systems. Their results and conclusions are in general agreement with the results presented herein. Although presently available results for all these study areas do not indicate any insurmountable difficulties in the dynamics and control of manned rotating space stations, further experimental results must be obtained before the systems investigated can be used in an actual station.

CONCLUDING REMARKS

Experimental and theoretical studies of the dynamics and control of manned rotating space stations indicate that the motions of the station can be adequately predicted by the theoretical analysis. The undamped wobbling motions resulting from disturbances, such as out-of-plane crew motions and docking torques, produce both attitude errors and an apparent rolling motion of the station floor. These undesirable motions can be minimized by use of a primary spinning-wheel wobble damper or a pulse-jet stability system, which acts as a backup and serves for the reorientation of the station. The small daily attitude precession required by the station to compensate for the orbital precession also appears feasible with either two small pulse jets or a permanent magnet in the station.

L
3
1
8
6

REFERENCES

1. Grantham, William D.: Effects of Mass-Loading Variations and Applied Moments on Motion and Control of a Manned Rotating Space Vehicle. NASA TN D-803, 1961.
2. Suddath, Jerrold H.: A Theoretical Study of the Angular Motions of Spinning Bodies in Space. NASA TR R-83, 1961.
3. Kurzahls, Peter R., and Adams, James J.: Dynamics and Stabilization of the Rotating Space Station. *Astronautics*, vol. 7, no. 9, Sept. 1962.
4. Adams, J. J.: Study of an Active Control System for a Spinning Body. NASA TN D-905, 1961.
5. White, John S., Shigemoto, Fred H., and Bourquin, Kent: Satellite Attitude Control Utilizing the Earth's Magnetic Field. NASA TN D-1068, 1961.

L
3
1
8
6

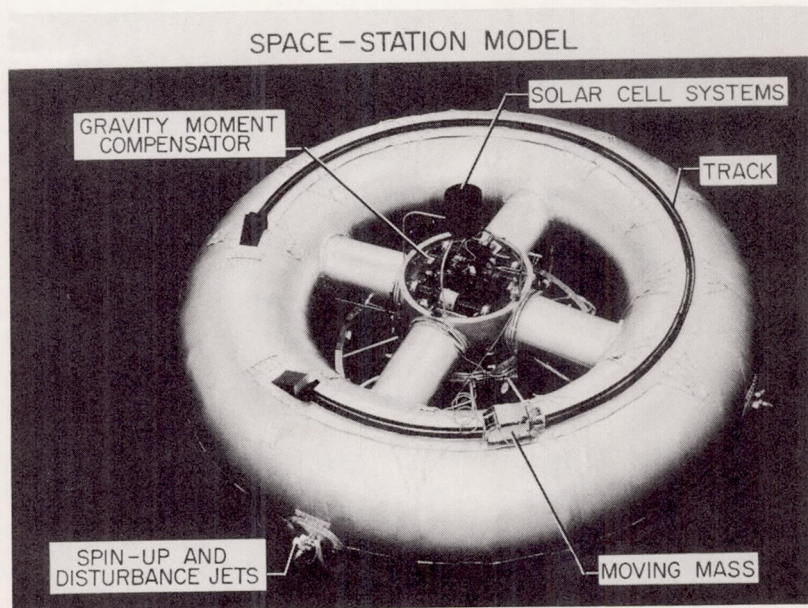

Figure 1

L-62-3919.1

MOTION OF UNCONTROLLED STATION FOR A TYPICAL DISTURBANCE

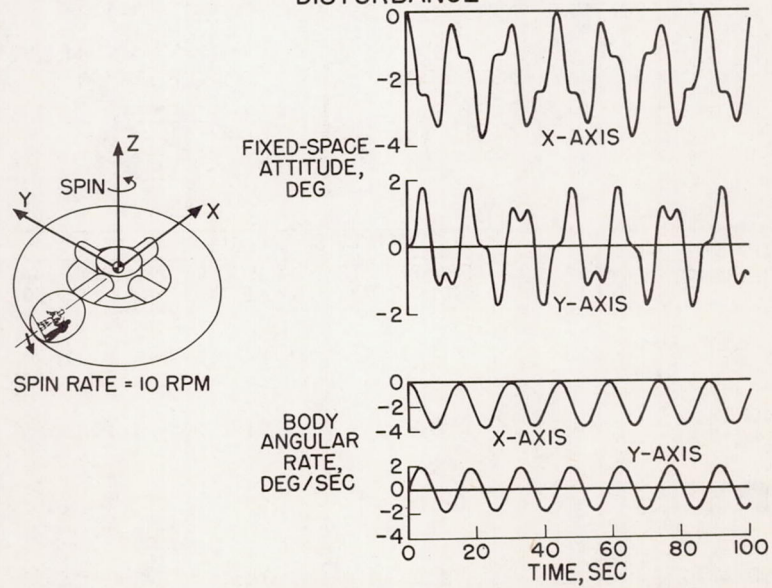

Figure 2

VARIATION OF MAXIMUM WOBBLE ANGLE WITH STATION INERTIA RATIO

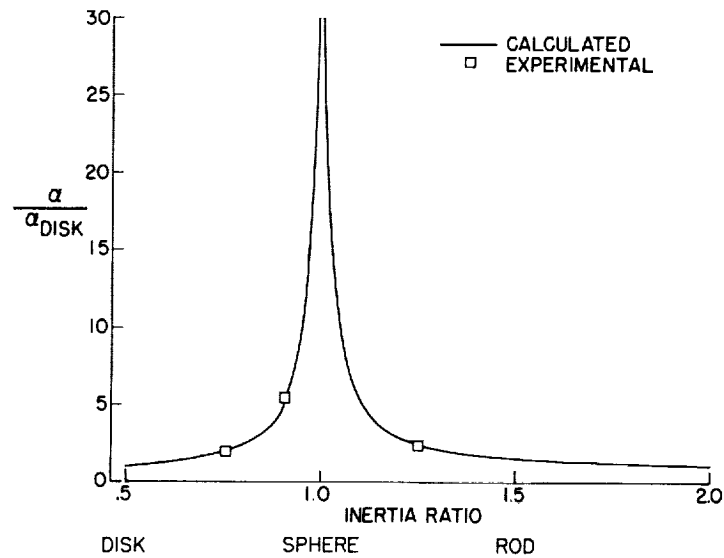

Figure 3

MAXIMUM WOBBLE ANGLES AND APPARENT ROLLING MOTIONS FOR TWO POSSIBLE CONFIGURATIONS

TYPE OF DISTURBANCE	DISTURBANCE EFFECTS			
	MAX WOBBLE ANGLE, DEG	APPARENT STA. ROLLING, DEG	MAX WOBBLE ANGLE, DEG	APPARENT STA. ROLLING, DEG
RADIAL CREW MOTIONS	9	0 TO 12	0.7	0 TO 0.8
TRANVERSE CREW MOTIONS	13	0 TO 5	1	0 TO 0.3
CIRCUMFERENTIAL CREW MOTIONS	108	80 TO -80	3	3 TO -3
DOCKING IMPACTS	2	2 TO -2	0.05	0 TO 0.04

Figure 4

MOTION OF CONTROLLED SPACE STATION WITH AN INITIAL ATTITUDE ERROR

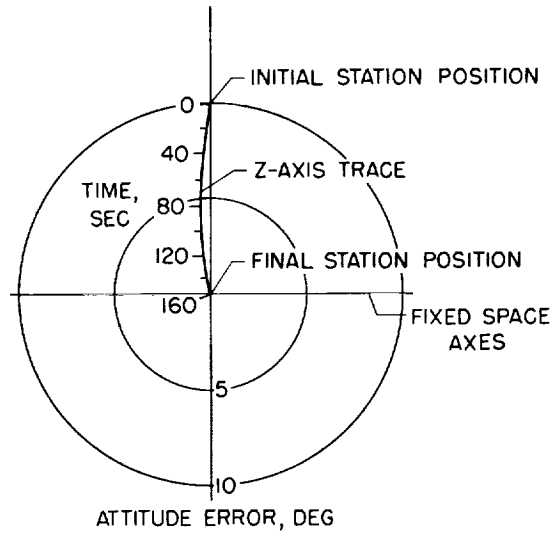

Figure 5

SCHEMATIC OF WOBBLE DAMPER

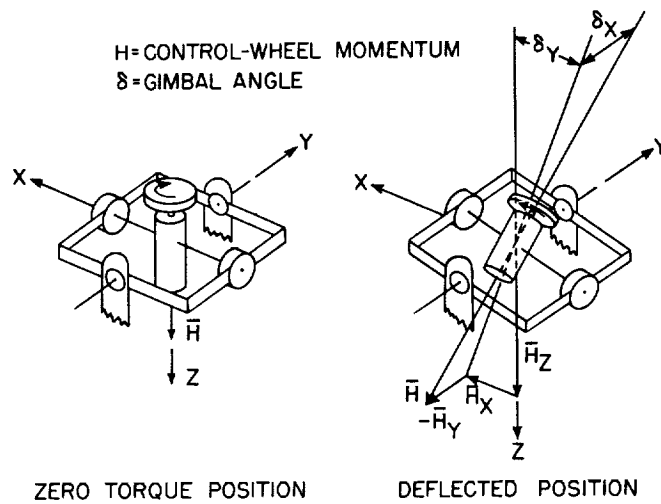

Figure 6

EXPERIMENTAL WOBBLE-DAMPER RESULTS OBTAINED
ON A STATION INERTIA SIMULATOR

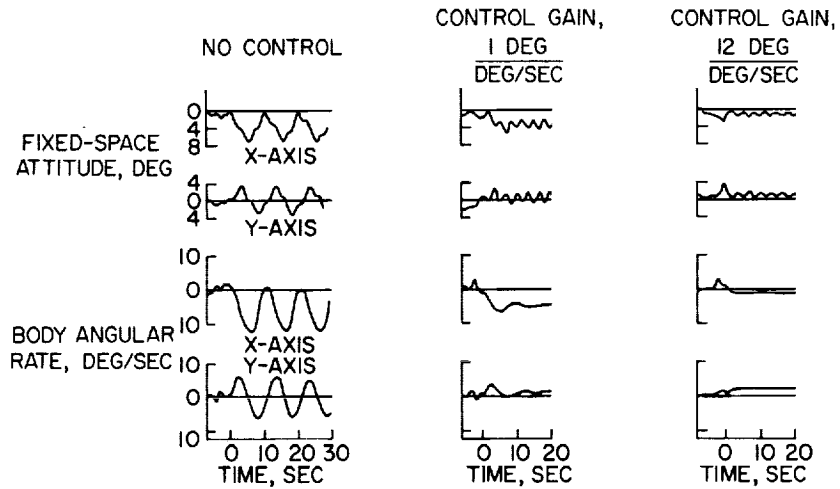

Figure 7

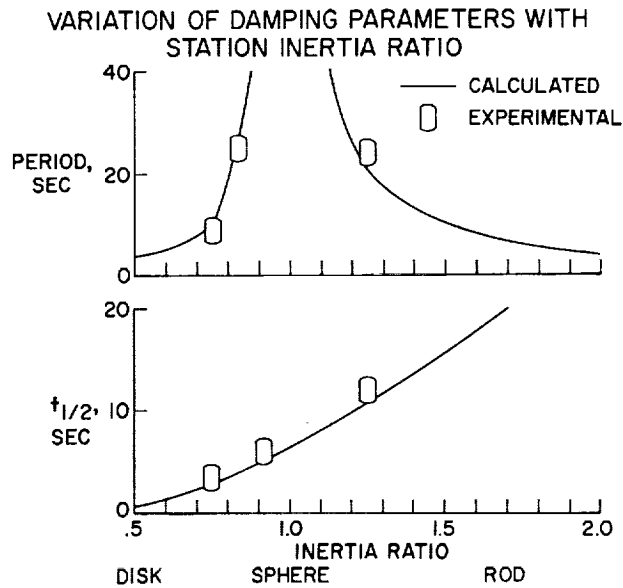
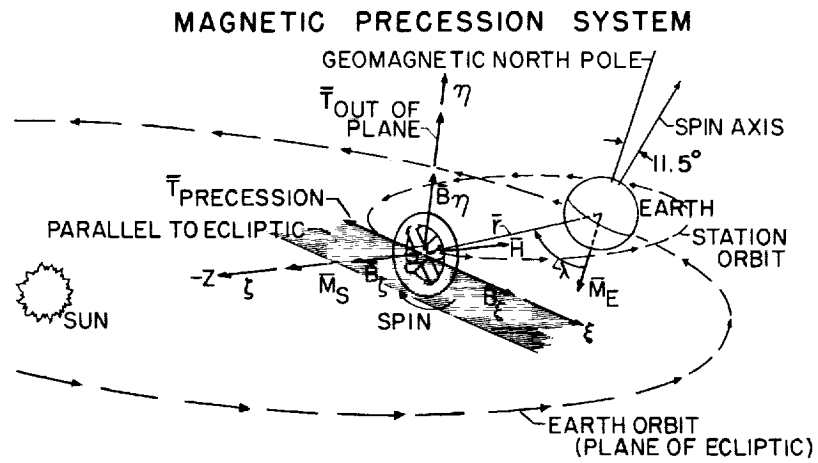

Figure 8



$$\vec{T} = \vec{M}_S \times \vec{B}$$

$$\vec{B} = f(\vec{M}_E, \vec{r}, \lambda)$$

Figure 9

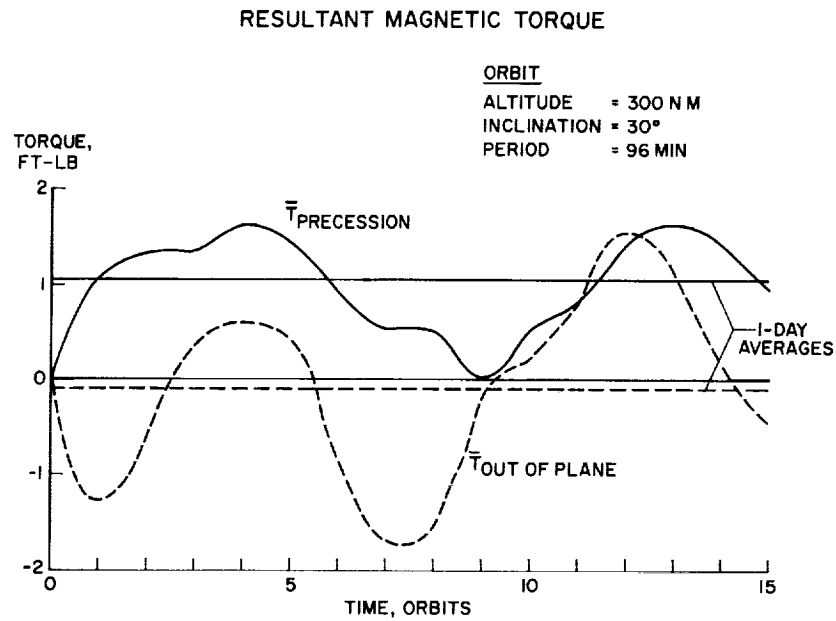

Figure 10

8. EFFECTS OF ROTATION ON THE ABILITY OF SUBJECTS TO PERFORM SIMPLE TASKS

By Ralph W. Stone, Jr., and William Letko

SUMMARY

Twenty-nine subjects were rotated in a closed chamber during which the rate of rotation was varied up to 17 rpm and six subjects were rotated for 3 hours at 10 rpm to determine the effects of simultaneous rotation of head and vehicle on the tolerance of subjects to rotation and on the ability of subjects to perform simple tasks. The results indicate that subjects could tolerate and adapt to higher simultaneous rotational rates than previously reported and also indicate that existing tolerance thresholds cannot be considered fully established but require further investigations for full confirmation.

INTRODUCTION

The artificial gravity of a rotating space station is, of course, a function of the rate of vehicle rotation, as indicated by the equation $g = \omega^2 r$ where g is centrifugal acceleration, ω is angular rotational rate, and r is radius of rotation. For the first-generation space stations, of fixed radius, the amount of g provided will have to be limited to a rate of rotation that is tolerable to man. Although studies to determine the acceptable minimum level of gravity cannot be made on earth, the maximum vehicle rates which are tolerable to man can be investigated. Man's intolerance to rotation is a result of certain disturbing side effects which are elicited as illustrated in figure 1. Suppose a person is oriented on a rotating vehicle as shown. Assume the vehicle rotational rate ω_v about the vertical axis and the head rate considered ω_h is about the long body axis. A cross-coupled acceleration results about the third axis, and its magnitude at any instant depends on the orientation of the head with the vehicle axis and on the magnitude of head rate and vehicle rate. Since the semicircular canals are essentially angular acceleration sensors, they respond to this cross-coupled acceleration by sending a signal to the nervous system indicating an apparent angular motion of the head about this third axis.

This indication is false inasmuch as it is evident that an angular motion of the head about the third axis is not actually taking place. This false cue of angular motion from the vestibular system is not

confirmed by the cues from visual and proprioceptive senses and causes a visual illusion of pitching rotation and nystagmus, an involuntary flicker of the eyes, both of which can lead to a state of disorientation and possible nausea. The visual illusion of pitching motion is somewhat different from that which you would expect from a normal pitching stimulus.

The visual illusion and nystagmus are mainly a result of the fact that the eyes and ears are interdependent in establishing clear vision in normal life. The abnormal conditions of a rotating vehicle upset this normal relationship and are a direct cause of the disturbances experienced. It is interesting to note that man is very adaptable to different environments and often, with training, can overcome these illusions. The object of this study is to examine man's ability to cope with those disturbances of rotation which can occur in a closed rotating vehicle.

SYMBOLS

K	constant in equation for cross-coupled acceleration (fig. 8)
t	time
α_G	cross-coupled acceleration
θ_G	apparent head displacement
ϕ_h	actual head displacement
ω_G	apparent pitching velocity
ω_h	head rotational rate
$\dot{\omega}_h$	angular acceleration of head
ω_v	vehicle rotational rate

TEST EQUIPMENT AND TECHNIQUES

Figure 2 is a view of the simple rotating-vehicle simulator used at the Langley Research Center in this study. Subjects were lying on their backs enclosed in the small cabin, with their feet 15 feet from the center of rotation. The centrifugal force was felt on the soles of their feet as it would be in a rotating space station.

The internal features of the rotating simulator are shown in figure 3. The subject's task was to observe the light on his left which was controlled by the experimenter who was located externally from the rotating vehicle. The color of the light could be varied by the experimenter, and the subject, upon observing a light of a certain color, was required to turn his head to the right and place a probe in the appropriate hole to extinguish the light. Head position and head rate were measured by the head-position indicator which was attached to a harness on the subject's head. Also measured was the time from light activation to light cutoff.

L
3
1
8
6

In the experiments that were performed, two types of tests were made, one of about 1-hour duration in which the rotational rate was varied from 0 to 17 rpm and the other of 3-hour duration in which the rotational rate was held constant at 10 rpm. In both these tests the sequence of colors and the time periods between light pulses were randomly chosen by the experimenter.

Figure 4 shows typical initial segments of the time history of light activation for both short and long tests and indicates the characteristics of the tests. Each line indicates an activation of the light and for the short tests the light was activated 24 times for each vehicle rotational rate. Rotational rates of 7, 10, 14, and 17 rpm were used. The light was activated 96 times during the 1-hour run whereas 500 light actuations occurred in the 3-hour run. The 3-hour run was made at a constant rotational rate of 10 rpm.

Twenty-nine subjects volunteered for the short test, including two test pilots. Six subjects, including five who participated in the short tests, also volunteered for the longer tests.

HEAD MOTIONS

One typical head motion, used by the subjects, is shown on the left side of figure 5 as acceleration, head rate, and displacement plotted against time. Angular head rates greater than 200 deg/sec and acceleration as high as 1,600 deg/sec² were used by the subjects.

Such head motions in the absence of vehicle rotation produce no ill effects because of accommodation by humans to normal motions. Combining each head rate and the vehicle rate of 10 rpm according to the equation for α_G shown on the right side of figure 5 results in the cross-coupled acceleration shown; this is the acceleration sensed by the semicircular canals. Also shown are the apparent velocities ω_G and displacements θ_G that result from this cross-coupled

acceleration. Note that an apparent pitching velocity ω_G of about 50 deg/sec results from this acceleration. It is of interest that 50 deg/sec is a relatively high scanning rate for the eyes. Since this apparent pitching motion sensed by the canals is not confirmed by other cues, a conflict of cues results which is highly disturbing as has been mentioned.

RESULTS AND DISCUSSION

The conditions discussed previously affect the average response time of the subjects, that is, the time from light activation to light cutoff. Figure 6 shows average response time Δt plotted against test time. The average response time of all the subjects at each rotational rate of the short-duration tests is shown by the circles; the stepped line indicates the length of time at each rotational rate. The average response time increases abruptly above 10 rpm, and this is the vehicle rate at which a number of the original 29 subjects began to drop out. The number dropping out increased with increase in rotational rate, and of the original 29 subjects only 16 completed the entire short-duration test. All six subjects completed the 3-hour run and their average response times are shown by the curve. At the end of the 3-hour run, the average response time is less than the value for 0 rpm, an indication of adaptation and perhaps some learning even for this simple task.

The effect of vehicle rotation on average head rate is shown in figure 7 as head rate in deg/sec plotted against time in minutes. The results for the short tests are again shown by circles and indicate that the head rate decreased at a vehicle rate above 10 rpm. This decrease indicates an attempt by subjects to reduce the cross-coupled acceleration to tolerable limits. The stepped line again indicates length of time at each rotational rate. The results of the long-duration tests are indicated by the curve. The initial head rate appears high in comparison with results for the short-duration tests, but examination of the data for the five subjects who participated in both tests showed that they used the same high head rate in each case. The head rate increased with time and toward the end of the run was 340 deg/sec, indicating some adaptation to the rotation. In fact, the subjects reported a marked decrease in the illusion of pitching motion, and they also reported that nystagmus, the involuntary flicker of the eyes, was almost completely eliminated; these changes occurred sometime between 1/2 hour and 1 hour of constant rotation.

In figure 8 head rate in deg/sec is plotted against vehicle rate in rpm. Circles in this figure represent the subjective results of the short-duration test. The first circle, at a head rate of 220 deg/sec and a vehicle rate of 10 rpm, represents the rates at which the subjects first found motion intolerable. These conditions were used to establish a tentative tolerance boundary. A hyperbola was passed through this point (according to equation shown on figure) and indicates a boundary of constant angular acceleration above which motion was intolerable for many of the subjects. Five subjects dropped out at the conditions represented by the second circle, and an additional seven dropped out at the conditions represented by the third circle. The dashed curve was obtained in the same manner as the solid curve, but is based on a maximum average head rate of 340 deg/sec, the final head rate used in the long-duration tests. This curve does not represent a tolerance boundary, but represents the maximum cross-coupled acceleration experienced by the subjects during the long-duration tests, with no disturbing effects. Note that this acceleration is higher than that tolerated by a large number of subjects in short-duration tests.

In order to correlate the present results with those of other investigations, data obtained to establish tolerance limits (refs. 1 and 2) were examined. The tests reported in the references were made in a slowly rotating room for periods of 2 days or more and are used by some people as the basis for vehicle design. The subjects in references 1 and 2 were given diversified tasks; they used random head motions and walked toward and away from the axis of rotation whereby they experienced Coriolis forces. The subjects of the referenced investigations first started to become incapacitated to some degree at about 1.7 rpm; this rate is indicated by the first dashed line (fig. 8). Similarly, the dashed line at a vehicle rate of 5.4 rpm represents a condition above which most of the subjects in the references found motion intolerable. In the references, some adaptation was indicated at the end of 2 days even at the higher rate. The fact that the Langley subjects could tolerate motion in the region where the subjects in the references generally found motion intolerable may be due to the fact that the latter subjects were oriented with their long body axis parallel to the axis of rotation whereas the Langley subjects were oriented with the long body axis perpendicular to the axis of rotation as they would be in a space vehicle. Another difference between the tests is that subjects in the references used random motions while the Langley subjects were restricted to a single type of motion.

In conclusion, it appears that the Langley subjects, upon completion of tests lasting 3 hours, adapted to cross-coupled acceleration as high as 6 radians/sec² and certainly adapted to rotations of 10 rpm with no apparent ill effects; however, the lower boundary of 4 radians/sec² (shown in fig. 8) might be used as a tentative upper limit of tolerance for vehicle design. Even though adaptation and training can increase

this limit, it is not necessary to subject initial occupants of space stations to the more stressful condition.

CONCLUDING REMARKS

The adaptation shown by the Langley subjects indicates that the tolerance thresholds cannot be considered fully established, but that further investigations of this problem are needed. Furthermore, the investigations should be extended to the study of readaptation to the normal nonrotating environment for emergency situations.

L
3
1
8
6

REFERENCES

1. Graybiel, Ashton, Clark, Brant, and Zarriello, J. J.: Observations on Human Subjects Living in a "Slow Rotation Room" for Periods of Two Days: Canal Sickness. Rep. No. 49, U.S. Naval School of Aviation Medicine (Pensacola, Fla.), Oct. 15, 1959.
2. Graybiel, Ashton, Guedry, Fred E., Johnson, Walter, and Kennedy, Robert: Adaptation to Bizarre Stimulation of the Semicircular Canals as Indicated by the Oculogyral Illusion. Rep. No. 464, U.S. Army Medical Res. Lab. (Fort Knox, Ky.), Feb. 23, 1961.

MOTION DEFINITION

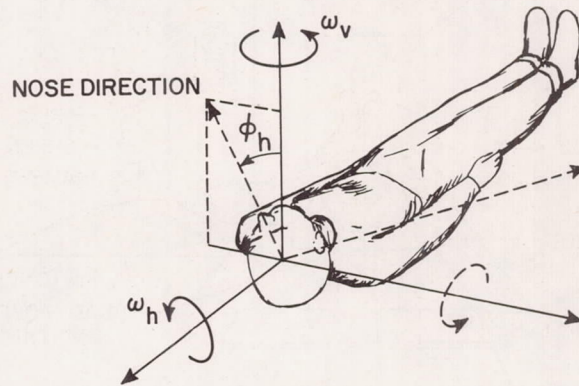

Figure 1

ROTATING - VEHICLE SIMULATOR

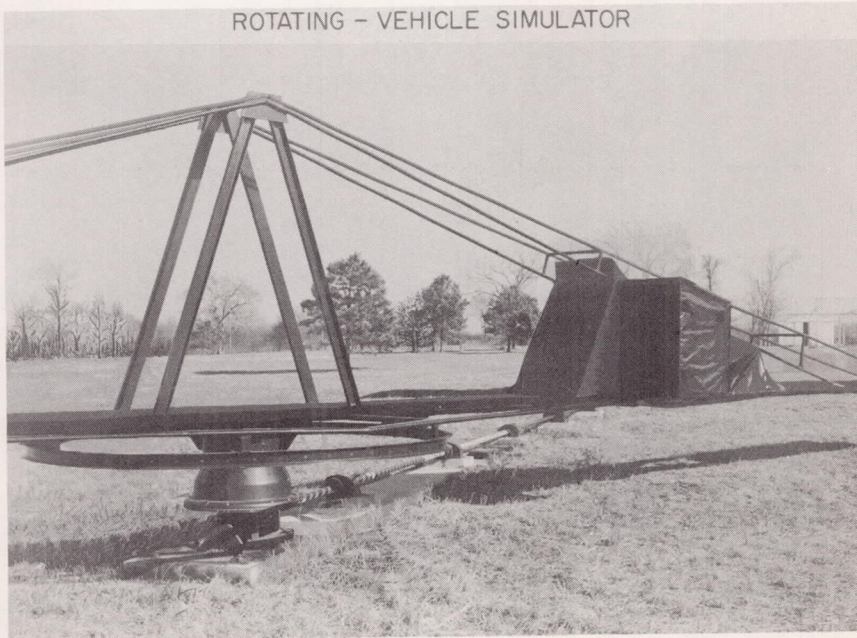

Figure 2

L-61-6978

INTERNAL FEATURES OF SIMULATOR

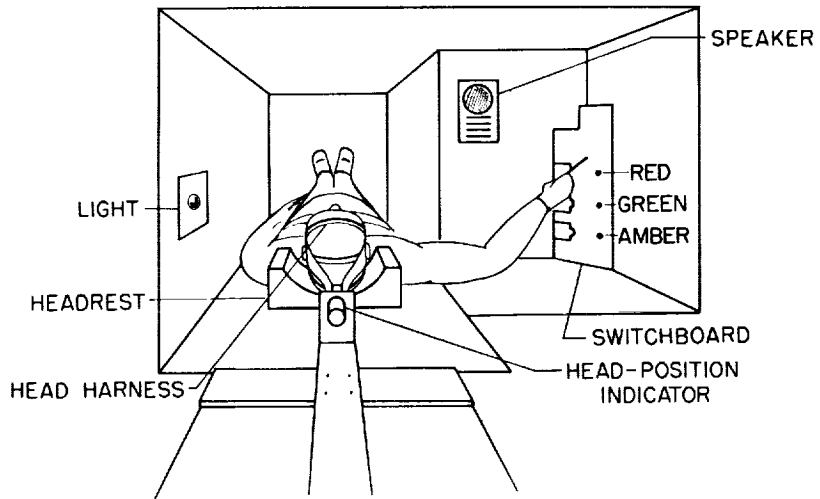
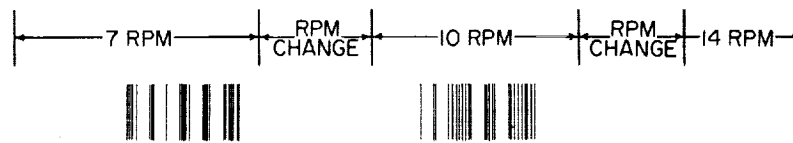

Figure 3

TASK HISTORY

TYPICAL SEGMENT OF 1-HOUR RUN



TYPICAL SEGMENT OF 3-HOUR RUN

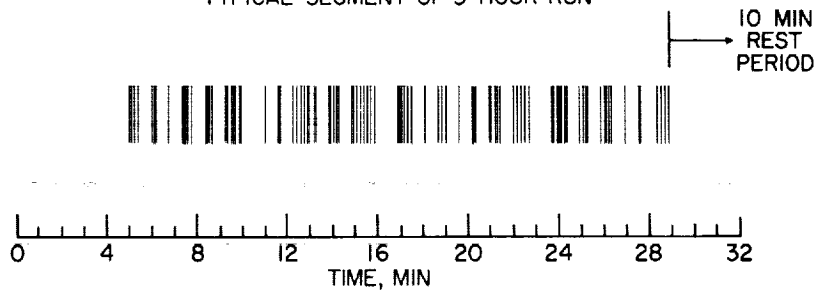

Figure 4

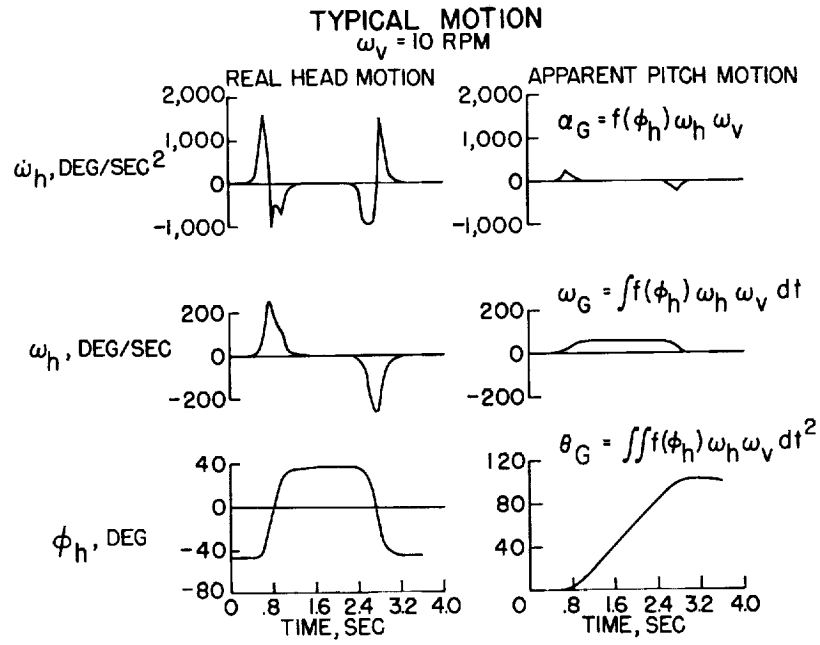

Figure 5

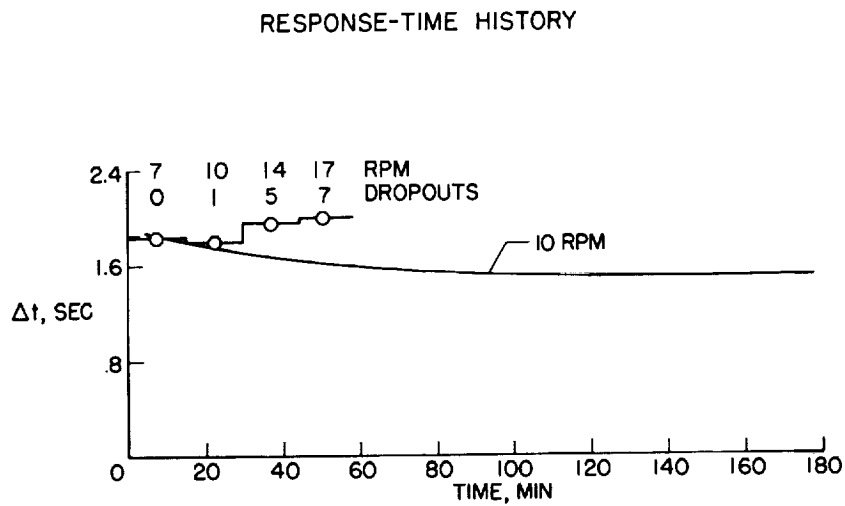

Figure 6

HEAD-RATE HISTORY

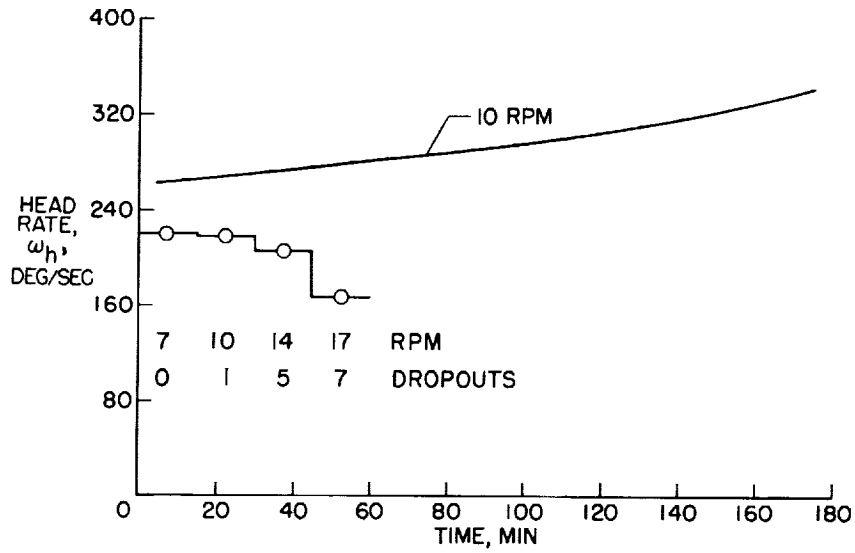

Figure 7

TOLERANCE TO CROSS-COUPLED ACCELERATION

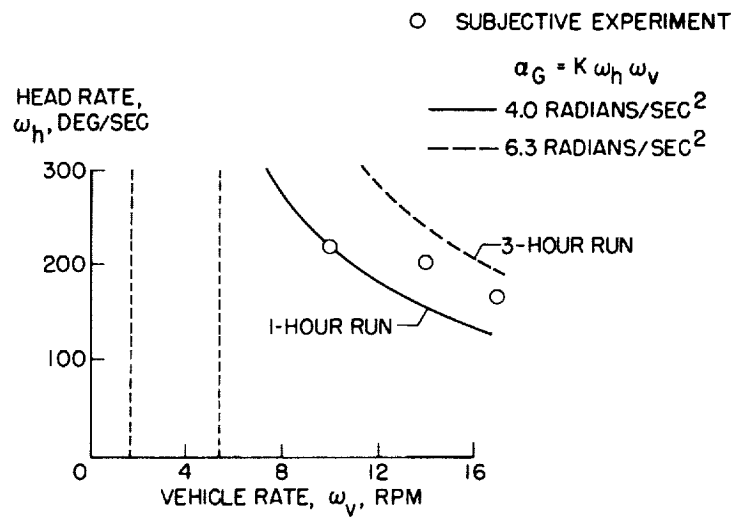

Figure 8

9. SOME CONSIDERATIONS OF THE OPERATIONAL REQUIREMENTS

FOR A MANNED SPACE STATION

By Roy F. Brissenden

SUMMARY

L
3
1
8
6

A survey has been made of the operational problems of a manned space station that would require an earth-to-orbit ferry for support. Some of the requirements of an earth-to-orbit shuttle service for ferrying personnel and freight to the station are set forth. Some general considerations, such as rendezvous, docking, abort, and reentry are discussed, and some considerations that are unique with the space station itself are brought out, along with suggestions for future research.

INTRODUCTION

For maintenance and support of a manned space station, a systematic ferry operation between the earth and the space station will be required. This shuttle service has to be set up on both a routine and an emergency standby basis which will involve transferring humans, both for crew rotation and rescue, and ferrying materials: consumable items, spare parts, replacements for gases and water lost through leakage or inefficient usage, and, possibly, power supplies.

A considerable amount of research has been done on space rendezvous, background information has been obtained on guidance and control of rendezvous, and the ability of human pilots to use various techniques to perform rendezvous has been investigated. It is not the purpose of this paper to discuss the general findings of these rendezvous studies but to consider those aspects of the ferry-operation problem which are unique or are closely associated with the operation of the manned space station itself.

PROBLEMS OF FERRY-OPERATIONS SUPPORT

Some of the major problems that will be involved in earth-to-orbit ferry operations in direct support of a space station are shown in figure 1.

Launch Windows

In planning the launch of a ferry supply vehicle, the ability to place it in the proper orbit to intercept the orbiting station must be considered. This planning concerns the time interval, or launch window, when the space station is in a favorable position relative to the ferry launch point on earth. Figure 2 shows the launch windows that generally apply for different ascent techniques. If direct ascent from earth to orbit of a ballistic type is used as the station passes overhead, rendezvous can be made if the launch is initiated during a period of about 2 minutes (refs. 1 and 2). This launch time is based on the capability of a ballistic type of ferry which has a final closing velocity (relative to the space station) of 1,000 feet per second and an orbital offset angle of less than 1° .

Greater offset distances (on the order of 4°) between the launch site and the orbital plane will be available if a winged ferry vehicle capable of turning aerodynamically is available or if a ballistic-type vehicle has available fuel to produce a component of thrust perpendicular to its flight path. In this case, the middle bar of figure 2 shows that the launch window may be widened to about 9 minutes. Thus, only several minutes are available for a launch period to effect rendezvous by the direct-ascent technique. For longer times, the parking-orbit scheme must be used; the launch window for this technique is on the order of 4 to 5 hours. Rendezvous times for the parking-orbit scheme, however, may require several hours because of the time required to make up angular-position deficiencies. The advantage of the increased launch window is lessened somewhat by the longer period of time required for rendezvous.

Mission Abort

In every manned flight, any time after the crew has been committed to the launch pad, the pilot must be able to abort his mission and to control a trajectory back to a desired landing area on earth while maintaining a reasonable level of deceleration. Many studies have been made of abort maneuvers both analytically and through static and dynamic piloted simulation. Studies have been made (for example, ref. 3) with an Apollo-type vehicle with a lift-drag ratio L/D of 0.5 to determine how the lift vector of the vehicle can be modulated during reentry. Aerodynamic control was obtained by rolling the ferry side-to-side to effect lateral translation, or by rolling upside-down, to point the lift vector down and to pull into the atmosphere. It was also determined how the pilot could fire a rocket perpendicular to his flight path as g loads built up in order to keep reentry deceleration below $8g$. These studies have also determined the size of possible landing areas as a function of the ferry velocity at abort. Because these studies have

been discussed and treated quite thoroughly elsewhere they will not be described further herein.

Terminal Rendezvous

L
3
1
8
6
As the elliptic transfer path of the earth-to-orbit ferry brings it to within less than 100 miles of the station, the terminal phase of rendezvous begins. A comprehensive study of the terminal rendezvous maneuver has been made both analytically and by means of simulators at the Langley Research Center. Piloted and automatic systems, some fully instrumented and some partially instrumented, were investigated with visual aids, state-of-the-art instrumentation, and various damping and thrust levels. See references 4, 5, and 6. Results of these investigations indicate that the terminal phase of rendezvous does not seem to present any difficult problems.

Rendezvous Docking

Preliminary studies of the problems of rendezvous docking have been made. Figure 3 shows typical results of a static visual docking simulation wherein the pilot controlled the translation of an attitude-stabilized ferry to make contact with a target vehicle which was also stabilized in attitude. The docking image was a 10-inch grid on a screen 8 feet from the pilot's eyes. The controlled vehicle was represented by a moving light spot which began with a 2-inch diameter and grew to a 10-inch diameter at contact. The task was the same as fitting a 10-inch ball in a 10-inch grappling square, both 8 feet from the pilot's eyes. In figure 3, all final position errors were less than 2 inches and the majority were less than 1 inch. The contact velocities in all cases were less than 0.1 foot per second. From 2 to 5 minutes were required for each run; the acceleration levels that were used are shown in the figure. The figure also shows that this type of docking maneuver is not difficult; however, the problem of docking one or more vehicles which have six degrees of freedom to a rotating space station is not this simple, and further studies are necessary to determine fully the difficulty involved. If the space-station docking hub is fixed while the remainder of the station rotates, docking will be very much like the general problem of joining two objects in space, but the problem of perfecting a gas-tight, rotating seal still exists. On the other hand, if the hub is fixed to the station and rotates with it, then the docking-control problem is further complicated, and requires establishment of the proper rotational rate as well as positioning and attitude control. These problems are recognized, and further research is needed to solve them.

Crew Size

Figure 4 shows the number of launches that are required each year as a function of space-station crew size for various duty cycles, or stay times, ranging from 8 to 40 weeks. A five-man ferry is being considered. If the space station can be operated with a crew of five, and if an 8-week stay time is chosen for the crew, then about six launches per year will enable the shuttle to perform routine personnel rotation. However, if more than five men are required to operate the station, and the number of launches is still limited to the six per year, longer stay times will be required. For example, if a fifteen-man crew has to be ferried to the station in six launches per year by using this five-man shuttle, then stay times will have to be 6 months. Basic material requirements are also based in part on the size of the space-station crew.

L
3
1
8
6

Supply Replacements

Ferry requirements may also be affected by the necessity for replacing oxygen lost through leakage. Additional supplies of fuel may also be required for postgrade thrust to maintain the nominal orbit and possibly for attitude control to point solar-cell panels at the sun as it precesses 1° per day. Some of the gases onboard the space station (such as CO_2) might be used for thrust. The CO_2 may be heated and expelled if the oxygen content is not reclaimed. However, regardless of the life-support system used, oxygen or some other gas must be supplied to the station by means of the shuttle.

A study by North American Aviation, Inc., assumes that the overall oxygen leakage from the station will be approximately 3,600 pounds per year - a level that would present no serious supply problem. Experience with the Mercury spacecraft provides another measure of the extent to which the leakage occurs at port seals in a space environment. If the Mercury leakage rate is scaled up to that which may occur with the space station, according to relative port perimeter sizes, a yearly leakage rate of 36,000 pounds is calculated for the space station. This leakage rate, logically based on present seal technology, is one order of magnitude greater than the optimistic estimate and would require four ferry launches a year for this replenishment of the oxygen supply alone. The leakage problem is of primary concern, and some studies are underway at the Langley Research Center to advance the state of the art in both static and rotating gas seals. One study is analytical, one uses a pressure-seal simulator, and another is concerned with full-scale environment testing of chamber seals. Preliminary calculations for the amount of fuel per year required to maintain the space-station orbit and precession are given in the following table:

Fuel	Fuel required, lb/yr, for -		
	Attitude control	Orbit keeping at altitude of -	
		300 NM	250 NM
CO ₂	2,600	1,010	3,860
H ₂ + O ₂	1,000	289	1,102
H ₂ (heated)	500	121	463

The requirements are shown for three types of fuel, and orbit-keeping fuel requirements are shown for two orbital altitudes. At orbital altitudes on the order of 300 miles or greater, attitude-control requirements are greater than orbit-keeping thrust, and at lower altitudes, the reverse is true as a result of increased drag. In any event, it can be seen that the leakage problem is the more critical.

Emergency Operations

In case partial or complete evacuation of the space station is required, the possibility of being able to return to earth immediately must be explored. It is of primary importance that geometric conditions be favorable for the ferry vehicle to land at a preselected site or sites. This general consideration is also true for routine shuttle return from the space-station orbit to earth. The ability to make an immediate reentry is directly dependent on the L/D of the ferry, the orbital altitude of the station, the number of landing sites available, and, to some degree, the inclination of the orbit. Figure 5 indicates the situation. This figure was computed for a 90-minute orbit. An Apollo-type vehicle may have up to 24 hours of hold time before it can reenter and land at a single site. On the other hand, the use of a vehicle with an L/D equal to 2.2 cuts the maximum hold time in half, or on the order of 12 hours. Furthermore, if the L/D value is increased to 4.4, or if four sites are available for a ferry having an L/D of 2, waiting or hold times are reduced to zero, and the ferry vehicle could start back to earth immediately.

RESEARCH FACILITIES

As mentioned previously, one of the major problems which remains to be studied in the ferry operations for a manned space station is

the final docking maneuver. Two facilities are being constructed at the Langley Research Center that are suitable for studying docking problems with pilot-controlled simulation. Figure 6 shows a schematic of a rendezvous-docking simulator which is designed for closed-loop docking studies in six degrees of freedom. The arrangement of the three-axis gimbal with the ferry cockpit suspended from an overhead carriage system which supplies translational motion is also shown in figure 6. The table at the bottom of figure 6 presents the characteristics of the rendezvous-docking simulator. This facility is designed to study space-station docking problems including the case of steady rotation. Figure 7 shows the second facility, a large outdoor gantry which is intended primarily for lunar-landing studies but which is also suitable for docking studies of actual flight hardware and thrusting rockets. The dimensions and characteristics of this facility are shown in the table at the bottom of figure 7. The facility is designed for a ferry weighing up to 20,000 pounds. The free-flight area for this facility is designed to be 400 x 165 x 50 feet, to have a maximum velocity of 50 feet per second, and to have adequate rotational rates and accelerations for the full-scale docking maneuver.

L
3
1
8
6

CONCLUDING REMARKS

A preliminary survey has been made of the ferry-support problems of a manned space station; considered are such items as launch windows, abort, rendezvous, docking, ferry trips for crew rotation, and the possible ferry requirements brought about because of space-station leakage and other fuel or supply replenishments. Some of the main problems requiring continued research are identified, such as rendezvous docking and supply requirements.

REFERENCES

1. Eggleston, John M., and Beck, Harold D.: A Study of the Positions and Velocities of a Space Station and a Ferry Vehicle During Rendezvous and Return. NASA TR R-87, 1961.
2. Bird, John D., and Thomas, David F., Jr.: A Two-Impulse Plan for Performing Rendezvous on a Once-a-Day Basis. NASA TN D-437, 1960.
3. Young, John W., and Goode, Maxwell W.: Fixed-Base Simulator Studies of the Ability of the Human Pilot to Provide Energy Management Along Abort and Deep-Space Entry Trajectories. Proc. Nat. Aerospace Electronics Conf. (Dayton, Ohio), Inst. Radio Eng., May 1962, pp. 472-486.
4. Brissenden, Roy F., Burton, Bert B., Foudriat, Edwin C., and Whitten, James B.: Analog Simulation of a Pilot-Controlled Rendezvous. NASA TN D-747, 1961.
5. Lineberry, Edgar C., Jr., Brissenden, Roy F., and Kurbjun, Max C.: Analytical and Preliminary Simulation Study of a Pilot's Ability To Control the Terminal Phase of a Rendezvous With Simple Optical Devices and a Timer. NASA TN D-965, 1961.
6. Brissenden, Roy F., and Lineberry, Edgar C., Jr.: Visual Control of Rendezvous. Aerospace Engineering, vol. 21, no. 6, June 1962. pp. 64-65, 74-78.

L
3
1
8
6

PROBLEMS OF FERRY-OPERATIONS SUPPORT
OF A MANNED SPACE STATION

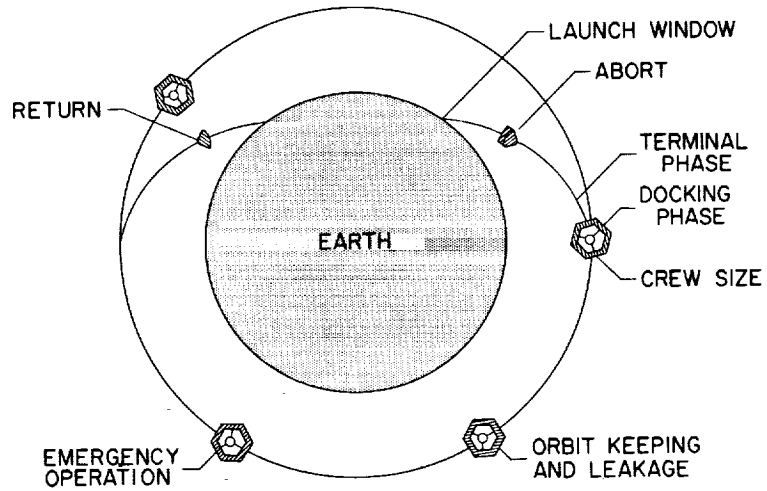

Figure 1

EFFECT OF ASCENT MODE ON LAUNCH WINDOW

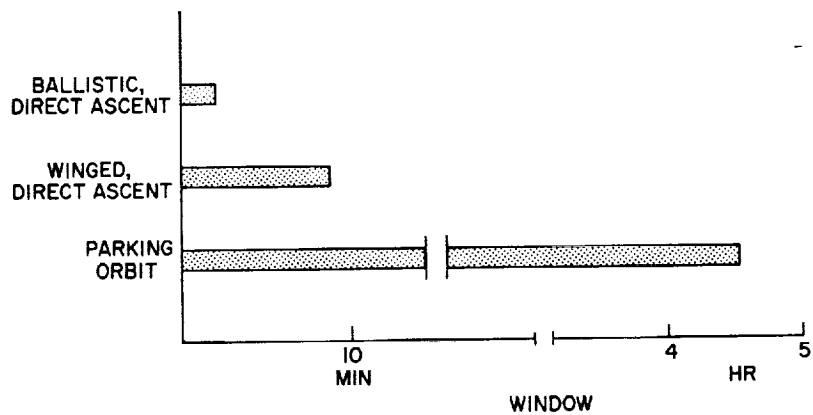

Figure 2

VISUAL RENDEZVOUS WITH TRANSLATION ONLY
 FINAL VELOCITY ≤ 0.1 FT / SEC
 VEHICLES ARE ATTITUDE STABILIZED

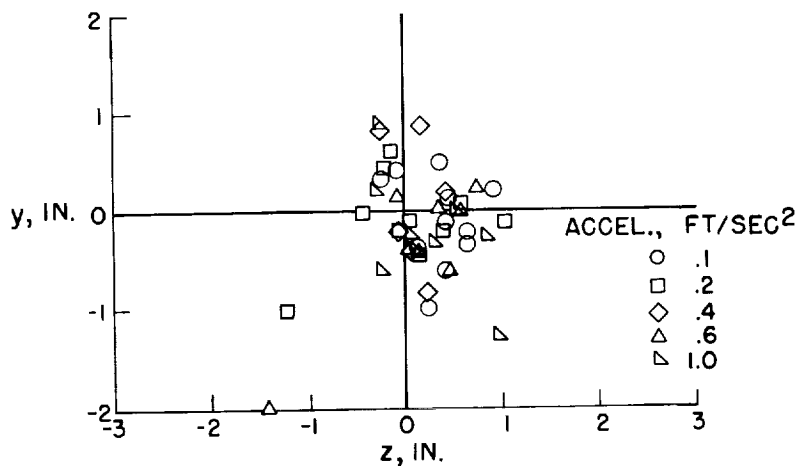

Figure 3

APOLLO/SATURN C-1
 (5 PASSENGERS PER LAUNCH)

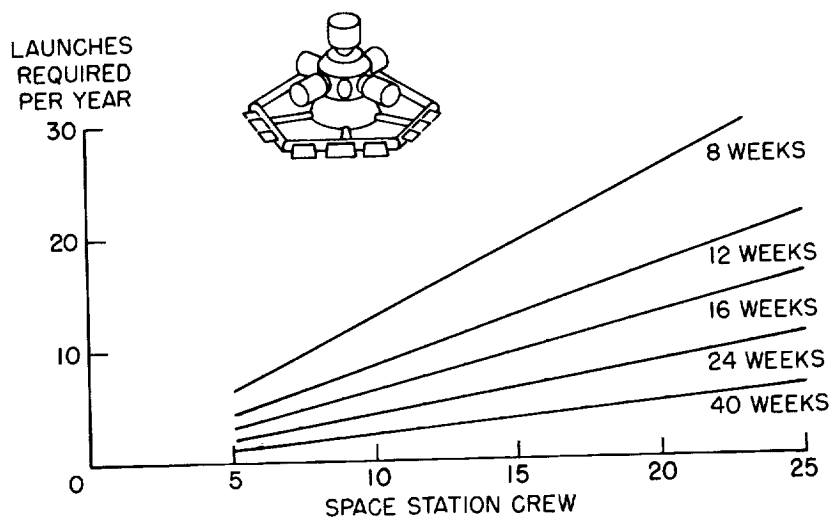

Figure 4

EMERGENCY OPERATIONS
 MAXIMUM HOLDING TIME IN SATELLITE ORBIT FOR
 LANDING AT EDWARDS AFB

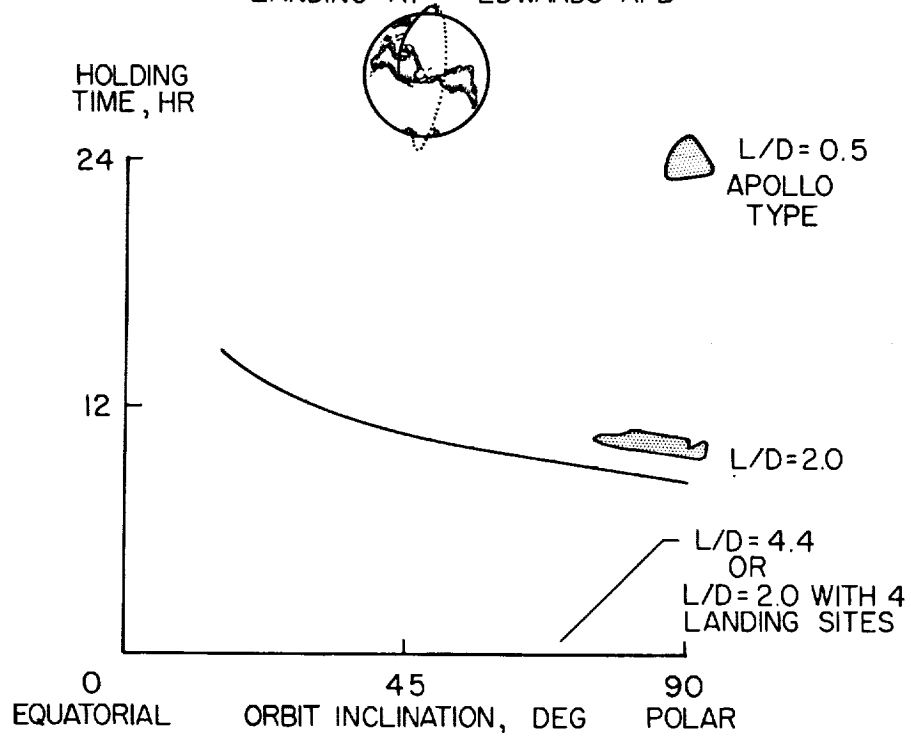
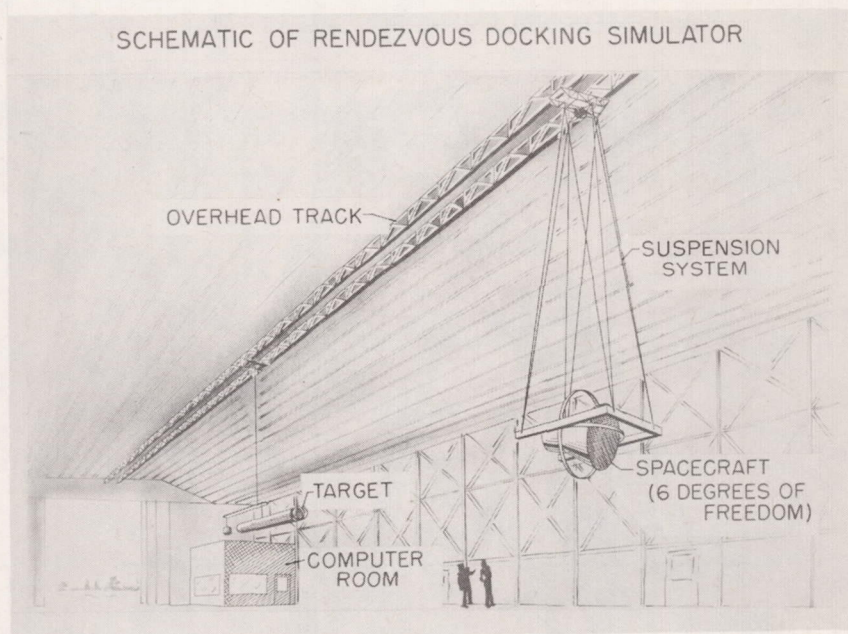

Figure 5



TRANSLATIONAL CAPABILITIES

DIRECTION OF TRAVEL	LENGTH, FT	RATE, FPS	ACCELERATION, FT/SEC ²
LONGITUDINAL	210	20	8
LATERAL	16	4	4
VERTICAL	45	10	8

ROTATIONAL CAPABILITIES

ATTITUDE ANGLES	RATE, RAD/SEC	ACCELERATION, RAD/SEC ²
PITCH	1	2
ROLL	4	8
YAW	1	2

Figure 6

LANGLEY LUNAR-LANDING RESEARCH FACILITY

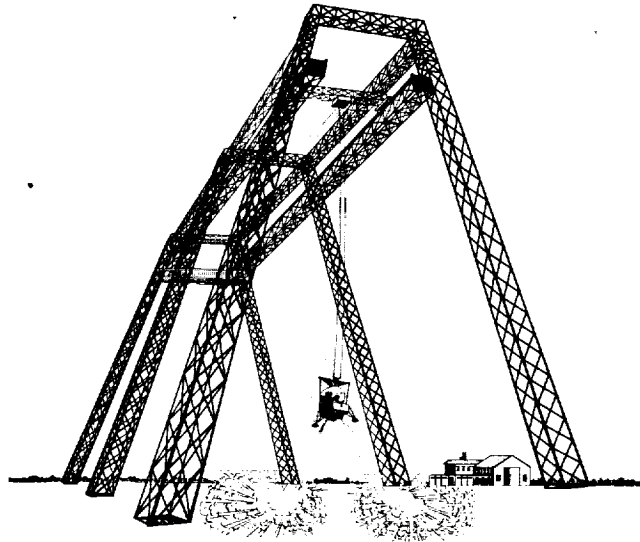

L-62-1010.1

TRANSLATIONAL CHARACTERISTICS

DIRECTION OF TRAVEL	LENGTH, FT	VELOCITY, FPS
HORIZONTAL	400	50
LATERAL	± 25	40
VERTICAL	165	10

ROTATIONAL CHARACTERISTICS

ATTITUDE ANGLES	ANGULAR TRAVEL, DEG	RATE, RAD/SEC	ACCELERATION, RAD/SEC ²
PITCH	± 45	0.5	0.5
YAW	± 260	0.5	0.5
ROLL	± 30	0.5	0.5

Figure 7

10. LIFE SUPPORT RESEARCH FOR MANNED SPACE STATIONS

By Dan C. Popma, Charles H. Wilson,
and Franklin W. Booth

SUMMARY

1
3
1
3
5
Requirements of life support for the crew members of a space station are considered in relation to man's metabolic requirements and metabolic products. Appropriate methods and equipment are related to these requirements and the characteristics of the space-station mission. Among the provisions required for maintaining physical well-being are systems for (1) the removal of carbon dioxide, (2) the reclamation and supplying of oxygen, (3) the control of temperature and humidity, (4) the reclamation of water, (5) the management of wastes, and (6) the supplying of food.

Some of the research being performed at the Langley Research Center with life support systems is discussed and the research objectives are stressed. Descriptions are given of the various types of equipment used in this research, together with criteria for system evaluations. Some of the relevant life support recommendations made by North American Aviation, Inc., are examined.

INTRODUCTION

The life support systems for a manned space station must fulfill two primary considerations: (1) supply the needs of the occupants of this vehicle and (2) be of minimum weight and have a minimum power consumption. The requirements of these occupants are, for the most part, fixed and cannot be varied without working a hardship, or worse, on them. The systems used to supply these needs and requirements can vary greatly, depending on mission duration and resupply capability. A block diagram showing the needs of a man together with the systems to fill these needs for space-station missions is presented as figure 1. In this diagram are indicated the inputs to the man - oxygen, water, and food - and the various outputs from the man - carbon dioxide, urine water, evaporated water, wash water, and fecal wastes.

LIFE SUPPORT SYSTEMS

To provide for the various outputs, several different types of systems are needed, such as carbon dioxide removal systems, oxygen

reclamation systems, temperature and humidity control systems, water reclamation systems, food supply systems, and waste management systems. These requirements are similar to those for nuclear submarines; however, for space vehicles, there are severe weight and power restrictions. There is no capability of obtaining water and oxygen from sea water and zero-g operation must be provided. Among the problems that occur in this area, but not shown, is the control of toxic trace gases that may build up within the closed environment.

The relative complexity of these systems varies with the length of time of the mission. For example, the Mercury spacecraft, with a mission time of less than 1 day required relatively simple systems. As the mission duration becomes longer, the weight of supplies needed for Mercury type systems becomes excessive and must be limited by providing systems that are regenerative or that reclaim some of the byproducts of the men.

Research which is being performed at the Langley Research Center into the problems of life support systems for space-station missions is described together with a brief description of the recommendations made by North American Aviation, Inc., (NAA) for these space stations. The systems listed in figure 1 are considered - that is, carbon dioxide removal systems, oxygen reclamation systems, humidity control and water separation systems, water reclamation systems, food provision systems, and waste management systems.

The research being conducted at Langley is not directed at the problem of producing systems for use in space vehicles. Rather, the objective is to gain knowledge of various system concepts, together with the required instrumentation and controls. This knowledge will form the basis for arriving at optimum concepts of practical and reliable space hardware.

Carbon Dioxide Removal

Considering the specific components for life support, a system for the removal of carbon dioxide from the vehicle atmosphere is necessary. Man, in the process of living, inhales oxygen and gives off carbon dioxide at a rate of about 2.2 pounds per man per day. This carbon dioxide, as a waste product of man, is toxic in concentrations greater than about 3 percent of atmospheric pressure. Many studies have resulted in the recommendation that this concentration be restricted to below 1 percent. Therefore, it is necessary not only to remove this 2.2 pounds per man per day of carbon dioxide but also to maintain the concentration to less than 1 percent of sea-level pressure.

NAA has recommended for this task a regenerative molecular sieve system. This system is the type of system being tested at Langley. As shown in figure 2 the system operates on the atmosphere of a vehicle to remove the carbon dioxide produced by the men. This removal is accomplished by means of molecular sieves which have an affinity for carbon dioxide. Two of these sieves are used alternately, one in the airstream adsorbing carbon dioxide while the other is desorbing. In addition, two silica gel beds are used to prevent water vapor from entering the molecular sieve beds since these sieves have a preferential affinity for water vapor; if large amounts of water vapor are allowed to enter them, these beds would absorb this water rather than the carbon dioxide. The airflow through this system is as follows: The air enters the system and is forced through the first silica gel bed where the water vapor present in the air is removed down to a few parts per million. From this bed, the air passes through a heat exchanger and is cooled because of being heated by the adsorption of the water vapor. From the heat exchanger, the air goes to a molecular sieve where most of the carbon dioxide is removed. The air then goes back to the heat exchanger to be reheated and enters the second silica gel bed where the moisture, which this bed had adsorbed in a previous cycle, is now desorbed into the airstream and the air returns to the cabin. Periodically, heaters within these silica gel beds are turned on to return these beds to the initial dry condition. Both sets of the silica gel and molecular sieve beds operate alternately: first adsorbing until they have reached their capacity for either water or carbon dioxide, and then desorbing this water or carbon dioxide either to the exit airstream or to an oxygen reclamation system. At present these systems are being tested by vacuum desorption of the molecular sieves. With oxygen regeneration, desorbed carbon dioxide will be fed into the oxygen reclamation system rather than dumped to a vacuum.

Some of the current tests with the carbon dioxide removal systems are, for example, the determination of the efficiency of carbon dioxide removal under varying carbon dioxide partial pressures, under varying total pressures, temperatures, and humidities. The effects of exposure to hard vacuums, as might be encountered in an emergency decompression, will be investigated.

One of the problems with these systems is the possibility of moisture breakthrough in the silica gel beds. A failure of the humidity control system, for example, would result in an input of high-temperature saturated air to these systems and would allow moisture to enter the molecular sieves. If this condition were continued without a drying out of the molecular sieves, they would ultimately lose their ability to remove carbon dioxide.

These tests, even at this early date, point out the necessity of a sensor to monitor the moisture level of the air entering the molecular sieves to guard against their being poisoned by water.

One other item of instrumentation is believed to be necessary: that for measuring the output carbon dioxide partial pressure. This, together with the system input partial pressure, will function as a monitor of the efficiency and safe operation of the carbon dioxide removal system.

Oxygen Reclamation

Man requires about 2 pounds per day of oxygen. This oxygen can be carried along with the launch vehicle, in which case it would require some 2,500 pounds of weight penalty each 6 weeks, or it can be reclaimed from the carbon dioxide given off by the occupants.

There are under investigation several ways of reclaiming this oxygen from carbon dioxide. The first of these is the Sabatier reaction which combines carbon dioxide and hydrogen to form methane and water. The methane is then pyrolyzed to form carbon and hydrogen, and the water is electrolyzed to form oxygen and hydrogen. The hydrogen formed in these two processes is then reused in the initial reaction. The Sabatier process is illustrated as follows:

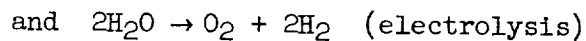
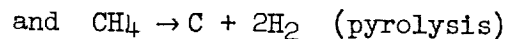
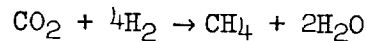

The second of these methods is the reverse of the reaction which has been used to produce artificial gas from coal and steam; carbon dioxide and hydrogen are reacted to form carbon and water, the water then being electrolyzed to form hydrogen and oxygen. The reverse water-gas reaction is illustrated as follows:

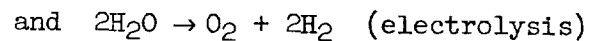
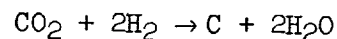

The third process utilized a solid electrolyte consisting of yttrium and zirconium oxide to operate on the carbon dioxide as follows: The carbon dioxide is passed through a chamber wherein these electrodes act to strip from a carbon dioxide molecule one atom of oxygen and to transport this oxygen through the electrode to a separate collector. The resultant carbon monoxide is then passed through a second reactor where,

L
3
1
8
6

by a catalytic reaction, carbon monoxide is converted to carbon dioxide and carbon with the carbon dioxide returning to the original input. The process utilizing the solid electrolyte is illustrated as follows:

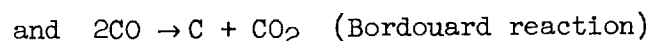
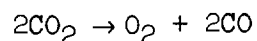

All these processes for the reclamation of oxygen from carbon dioxide are somewhat costly of power. The theoretical minimum power required to do this reclamation is 1.13 kilowatt-hours per pound of carbon dioxide. Practical processes require several times this theoretical minimum. For the first two processes, most of this power is consumed in the electrolysis of water, whereas with the solid electrolyte most of the power will be required in the electrolytic cell. In paper no. 6 it was pointed out that the solar power unit described by NAA does not include the power required for an oxygen reclamation system. NAA has, rather, proposed a separate solar array with rechargeable batteries specifically to supply its estimate of 12 kilowatts needed for a 38-man crew.

The process recommended by NAA was the Sabatier reaction. However, it is believed that perhaps the use of the solid electrolyte is more straightforward and presents fewer difficulties, in that the solid electrolyte does not require the electrolysis of water, the use of hydrogen, or the separation of any liquids from gases. This system (fig. 3) is intended to operate in the following manner: Carbon dioxide is fed into the system at a rate of about 6.6 pounds per day and enters the solid electrolyte cell. A part of the oxygen contained in this carbon dioxide is stripped off and is recirculated back into the cabin. The remaining carbon dioxide and the resulting carbon monoxide is then fed into a catalytic converter where the carbon monoxide is converted to carbon dioxide which is fed back to the solid electrolyte cell.

The oxygen that man consumes in his metabolic process appears as a product not only in the exhaled carbon dioxide but in exhaled water vapor as well. It is obvious that recovery of oxygen solely from the metabolic carbon dioxide in a closed system would not be adequate to balance the cycle. It becomes necessary to furnish the remaining oxygen required by reclaiming it from water. The ratio of the oxygen recovered from water to that recovered from carbon dioxide would be approximately 1:4. The solid electrolyte system has the capability of reclaiming oxygen from the water vapor supplied to it. The hydrogen resulting from this process will then have to be removed and discarded.

Humidity Control

The problem of humidity control and zero-g water separation is one for which many solutions have been put forth. The Mercury spacecraft system uses a heat exchanger to cool the airstream and a sponge which is periodically squeezed to trap and remove the entrained water in this airstream. NAA recommends the use of a centrifugal-type water separator to remove the entrained water; however, no details are available.

The NASA has a contract with the Janitrol Aero Division of Midland-Ross Corporation for a humidity control and zero-g water separation system which has a capacity for removing about 15 pounds of water per day, with an output humidity of about 50 percent. In this system (fig. 4) the airstream is cooled by a heat exchanger. This heat exchanger uses radiation to space and an intermediate liquid cooling loop. The incoming air is cooled to about 45° F which is below the dewpoint of this air; as a result water droplets are formed in the airstream and on the cooling fins. Downstream from the heat exchanger, the air and water droplets encounter a rotating centrifugal separator which separates the water from the air and forces the water to collect in a rotating circular tank. The water from this tank is then collected by an impact tube and passes to a holding tank for reclamation. This system has the capacity of operation in any acceleration environment from zero to 1g.

L
3
1
8
6

Water Recovery

Man requires about 5 pounds per day of water for drinking. To supply 21 men in this space station with water in storage tanks would require some 2.5 pounds per man per day of stored water (2.5 pounds of additional water being assumed to be available from the dehumidifier). This would require some 2,300 pounds of water each 6 weeks, plus tankage, with no allowance for wash water or an accumulation of about 2,300 pounds of urine. At a cost of about 300 pounds of weight and 300 watts of power, this urine can be reprocessed and reused. A contract has been completed by the American Machine & Foundry Company (AMF) for a water reclamation system which was built according to NASA design specifications.

This water reclamation system is capable of the reclamation of water from urine and wash water in a zero-g or partial-g environment. A preliminary test shows excellent results. This system has the capacity for purification of 10 pounds of water in a 6-hour period at a cost in power of about 100 watt-hours per pound. The system has an empty weight of about 50 pounds and occupies about 3 cubic feet.

Figure 5 shows how the system accomplishes its task. The waste liquid to be reclaimed is introduced into the inner cylindrical chamber by means of the filling tubes. This inner chamber rotates, giving the system its zero-g operating capability. The left side of this diagram shows the position that the waste liquid will assume with this rotation under a zero-g condition and the right side shows the position that the

L
3
1
8
6

liquid will assume under partial-g rotation. The pressure within the unit is lowered to about 0.35 psia, and at a temperature of about 70° F the waste liquid will boil. The water vapor from this liquid is then drawn into a pump and expelled into the outer chamber at about 0.70 psia. This increase in pressure will cause the vapor to condense on the coolest surface. In this device the heat of vaporization (1,000 Btu per pound of water) is transferred through the wall, back into the inner chamber to aid in the evaporation of the water from the waste liquid. As the water vapor condenses on the exterior of the rotating chamber, it is thrown off and collects on the outside wall of the condenser. Other gases which come off the waste liquid do not condense but continue out the purge valve.

After the process of reclamation has been completed, a valve in the condenser is opened and the water is pumped from the device through an ion exchange cartridge (not shown) which will remove any small impurities which may remain. This reclaimed water is then stored in a holding tank for consumption. The residual waste material in the evaporator is then discarded by removing the plastic inner liner in this chamber and storing it in the base of the device.

Problem areas with this system include the necessity of minimizing the water lost to space through the purge valve. This loss at the present time amounts to somewhere around 6 percent of the reclaimed liquid. Also, the optimum operating pressures and temperatures are yet to be defined.

In addition to this system for the reclamation of water from urine and wash water, the NASA has awarded contracts for three other water reclamation systems: a system for the reclamation of water from feces as derived from the waste management system, a system to purify water from the dehumidifier for drinking, and a system specifically designed to operate on wash water to render it reusable for further washing.

Food Supply

For manned space missions lasting more than a day, consideration must be given to man's food supply.

On the basis of 3 pounds of food required per man-day, a 6-week mission would require 2,600 pounds of food for the 21-man complement. Unlike oxygen and water, solid food cannot economically be regenerated for missions of this duration. The basic problem, then, is to minimize the food resupply weight and at the same time to provide an adequate diet for the crew members.

With these problems in mind, Whirlpool Corporation Research Laboratories under subcontract to North American Aviation, Inc., conducted a feasibility study of foods and feeding methods as a part of the overall mission study. The results of the Whirlpool study indicated that food resupply weight could be materially reduced without sacrificing dietary provisions. It was recommended that the menu be composed predominantly of precooked freeze-dehydrated foods which can be reconstituted by the addition of hot or cold water from the water reclamation system.

The resultant weight saving is derived from the fact that in freeze-dehydration most of the water is removed from foods. According to the study, the total food resupply weight would be reduced from 2,600 to 1,300 pounds by using this concept.

L
3
1
8
6

Although the study has shown what can be done with freeze-dehydrated foods, there is reason to believe that these weights could be even further reduced. The dietary allowance assumed by the study was based upon 2,500 calories per man-day. There is evidence to suggest that this dietary allowance might be reduced by as much as 25 percent.

The Whirlpool study included food-storage and feeding configuration concepts as they might apply to the manned-space-station study.

Waste Management

A consideration that follows naturally from food and feeding is that of providing for the collection, processing, and storage of human wastes. Management of these human wastes must be provided for crew members living in confined quarters for lengthy periods. A collection problem obviously arises as a zero-g field is approached; however, even in a partial-g field, the methods of transporting and disposal of wastes cannot be completely conventional. In addition, some provision for system comfort and ease of use must be considered. Solution of these problems will depend heavily upon the mission characteristics, such as g-levels, length of mission, power, weight, volume allotments, and others.

Considering waste management for the space station, it can be seen that storage of raw wastes for a 6-week period would result in a total of 3,100 pounds of wastes. If it is recognized that most of this raw waste is in the form of water, it becomes obvious that removing and recycling of the water could greatly reduce the weight of the stored wastes. A 100-percent efficient water removal and processing system would reduce the storage requirement to 100 pounds for the dried wastes each 6 weeks.

North American Aviation, Inc., recognizing the need for waste management provisions in its space-station concept, included consideration of this life support system in its overall study. NAA has recommended a system (fig. 6) that calls for separate collection of feces and urine and which solves the zero-g collection problem by providing for a directed flow of cabin air past and under the man; this air carries the fecal waste into a vaned impeller. After completion of defecation, the feces collection unit is closed and flushed by metering in a small amount of stored urine and rotating the impeller. This flushing operation transports the waste slurry to a water separation press where water is removed for processing and recycling.

There are two problem areas with this waste system: the difficulty of processing water squeezed from the feces and the relatively low effectiveness of the press used for separating this water from the feces.

An alternate approach is based upon a proposed design by the American Machine & Foundry Company. (See fig. 7.) The collection of feces is again accomplished separately from the urine collection and is aided by airflow. No flushing operation is required, however, since the feces are collected in individual containers which have porous disposable liners. After defecation, the containers are capped and placed in an oven where heat is applied and water vapor and other volatile constituents are removed for purification. The dried feces are then removed within the liner and are placed in a storage compartment. The outer container is then ready for reuse.

The urine is collected in a bellows assembly, and in a separate operation the urine is transported directly to a storage tank for processing.

A prototype system based on the AMF proposal is being fabricated under contract. Upon completion this unit should be evaluated at its rated capacity. To simulate desired environmental conditions and operational duration, the evaluation should be conducted within a life support chamber for extensive periods. The possibility of bacteriological and toxic contamination should be a major consideration.

CONCLUDING REMARKS

Many aspects of the life support systems for a manned orbiting space station have been examined. Many problems associated with these systems are yet to be solved; however, it is hoped that the solution to the problems will be forthcoming from the research which is being and will be conducted. The function of this research is not to produce hardware for space vehicles. The purpose is to evaluate and

originate basic concepts of life support systems. The knowledge obtained will form the basis for optimum-system concepts. The application of this knowledge will provide for practical, reliable life support systems for manned space vehicles.

LIFE SUPPORT SYSTEM

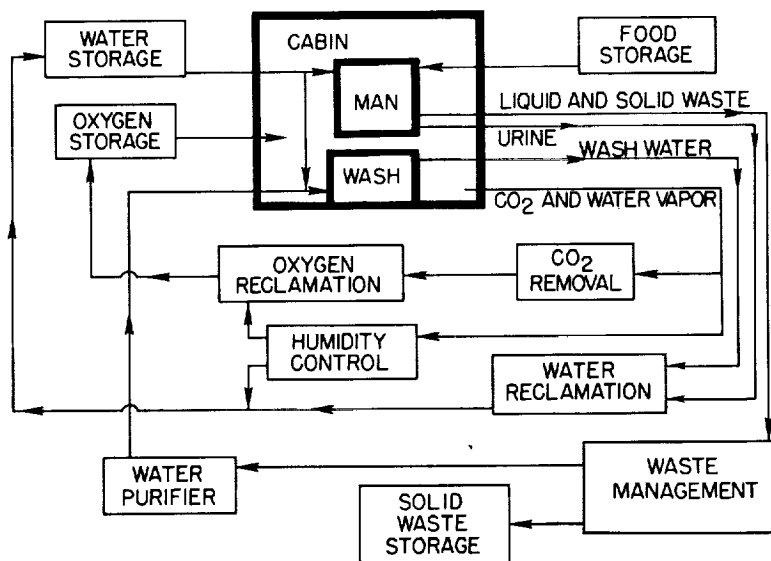

Figure 1

CARBON DIOXIDE ADSORPTION SYSTEM

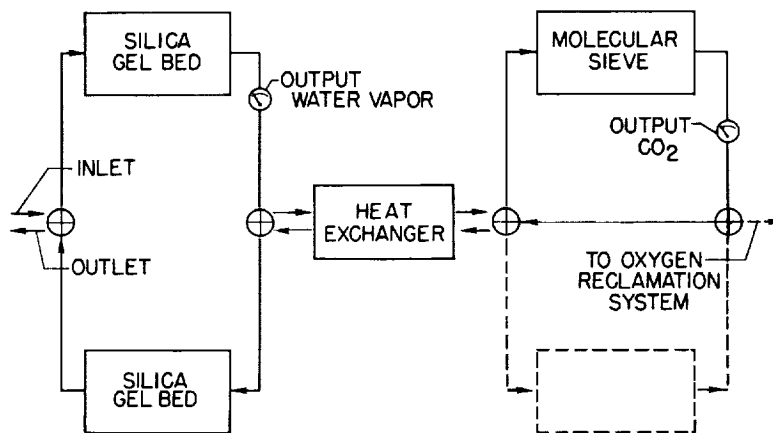

Figure 2

SOLID ELECTROLYTE OXYGEN RECLAMATION SYSTEM

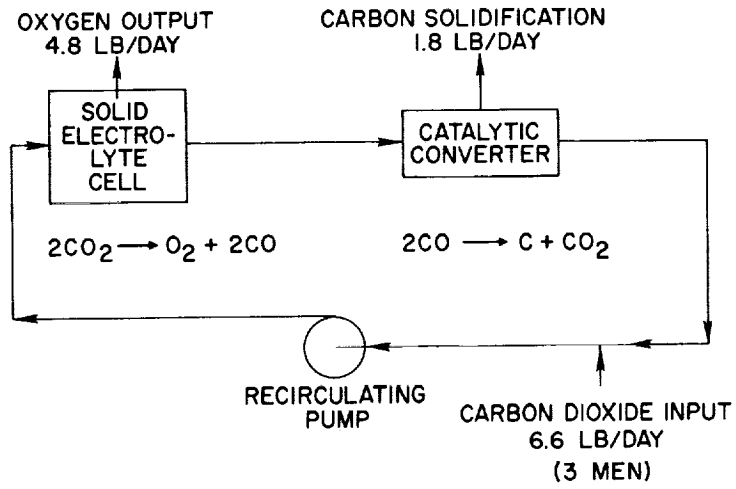

Figure 3

HUMIDITY CONTROL AND ZERO-G WATER SEPARATOR

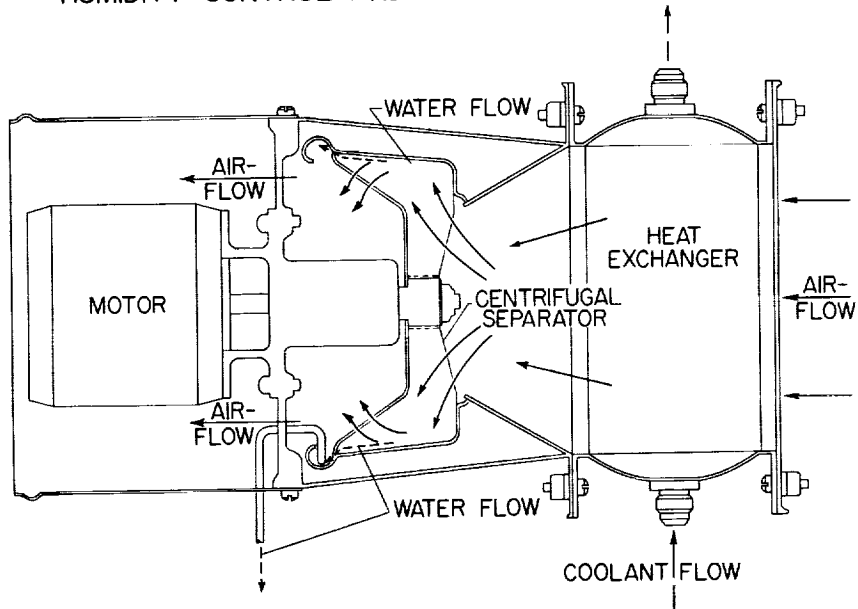
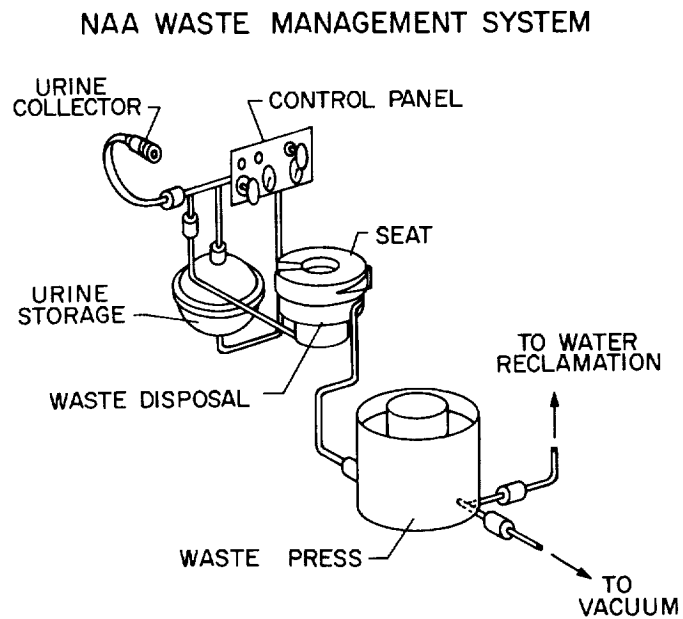
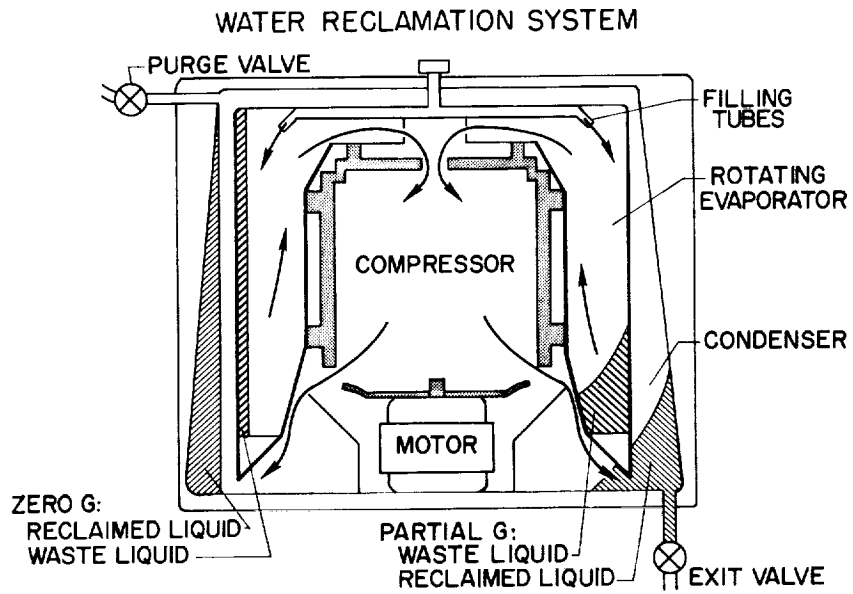

Figure 4



AMF WASTE SYSTEM

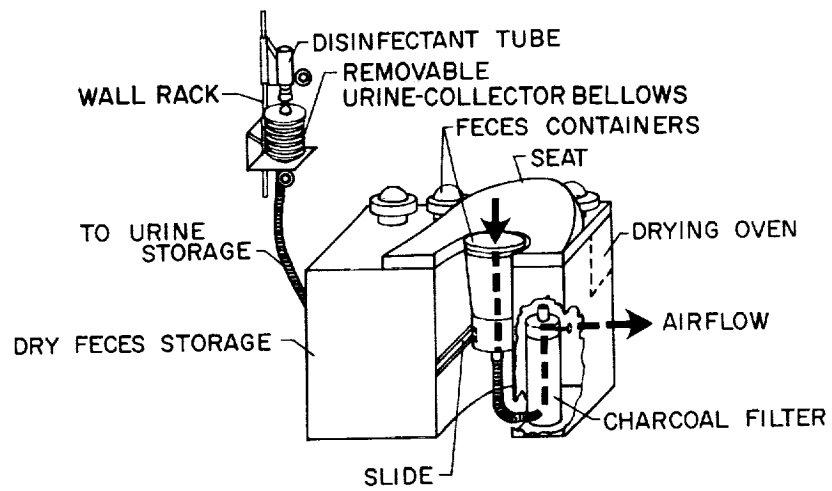

Figure 7

11. STRUCTURAL DYNAMIC ASPECTS OF LAUNCH-VEHICLE—SPACE-STATION COMPATIBILITY

By Harry L. Runyan and George W. Brooks

SUMMARY

L
3
1
8
6
Several phases of the compatibility of the C-5 launch vehicle with deployable space stations are discussed. Major load sources prior to and during launch are considered, and the results of analyses of both rigid and elastic body responses to the loads are presented. Natural frequencies and mode shapes of an anticipated cluster configuration are given which point out phase differences between the individual motions of the elements in the cluster and the overall elastic deformations of the vehicle. The results of an analysis of the control requirements indicate that the gimbal angles associated with current control systems are realistic for anticipated launch winds. A review of the anticipated acoustic and vibration environments of the C-5 launch configuration is presented, and the paper is concluded with a discussion of current problem areas and facilities for research on structural dynamics of launch-vehicle—space-station systems.

INTRODUCTION

The first 2 minutes are one of the more critical periods in the life of a space mission. A large number of static and dynamic loads can arise which, acting simultaneously or even singly, can result in failure of the mission. In particular, design of the spacecraft cannot be divorced from that of the launch vehicle, and compatibility of the two is a vital matter requiring study early in the design.

In figure 1, some of the more important loading sources are indicated. Before engine ignition, but after the gantry has been removed, ground winds can induce rather severe loads, both a steady drag load and a dynamic response in a direction mainly normal to the wind direction. Even small changes in aerodynamic shape, particularly at the top portion of the vehicle, can result in large changes in the vehicle response. Wind-tunnel tests are almost mandatory to determine acceptable solutions to this problem. A ground-wind model of C-5 is now in the planning stage for use with an Apollo spacecraft, and a model of the final configuration of the C-5 and space station is being considered for inclusion in the program.

At engine ignition and launcher release, longitudinal transients are induced which can be rather severe and are important, not only from the standpoint of basic structural strength, but also with regard to effects on smaller components. For instance, when using an erectable structure, most of the equipment has already been installed in the space station. If long tubes are used for the main structure, the equipment must be fastened to the thin-walled structure, and the longitudinal acceleration, both dynamic and steady state, will impose rather severe localized attachment loads and deformations. Also, the engine noise in the presence of the ground is of high intensity and, for these larger vehicles, the higher energy content is shifting to the lower part of the frequency spectrum, a portion of which may be below the audible range.

During flight through the transonic to the maximum-dynamic-pressure flight regime, various steady-state and oscillating aerodynamic loads become important. These include boundary-layer noise, winds and wind shear, and the static high-pressure peaks around geometric discontinuities at transonic speeds upon which are superposed buffeting loads. In this same flight regime, consideration must be given to the vehicle stability and control in the presence of high-velocity horizontal winds such as the jet stream. Another stability problem involves flutter, either of the components such as fins or of a localized area involving thin panels.

The stability and control of the complete system and the system compatibility are discussed first; then consideration is given to the high-frequency environment to which the space station might be subjected during launch.

STABILITY AND CONTROL

Most of the major system elements are involved in the stability picture, as shown in figure 2. These include the low-frequency vibration modes of the structure, fuel slosh, aerodynamics, and the control-system characteristics. Therefore, the aerodynamic shape as well as the flexibility of the payload may have a strong influence on the control-system design.

Control Requirements

In studying the system, the complete vehicle may be characterized as a transfer function upon which the various external loadings, such as winds, are imposed. Outputs are in the form of launch-vehicle motions and loads. Before the control and loads are studied, the system must be stable, even in the absence of the inputs. With the system stabilized,

L
3
1
3
5

the required control (engine gimbal angle) can be determined for various wind inputs. The configuration selected for study includes the first two stages of C-5 with a payload consisting of a six-module arrangement on top of which is mounted the central hub and an Apollo spacecraft. Total payload weight is about 170,000 pounds. The control system is rather simple, consisting of pitch (θ) and pitch-rate ($\dot{\theta}$) sensors. By proper selection of system gains a stable system has been obtained. The next question involves the capability of the engines to control the system in the presence of external disturbances. In figure 3 is shown the maximum engine gimbal angle required to control the vehicle as it flies through a design 2σ and 3σ wind, plotted against pitch frequency. This pitch frequency is the natural frequency of the rigid vehicle, including the control system and an idealized engine, and is a function of several parameters, one of which is the control-system gain. On the right of the figure is a plot of the 3σ design wind, which peaks at 35,000 feet with a wind speed of 300 ft/sec. The 2σ design wind has a similar shape but has a maximum speed of 256 ft/sec. As can be seen, there is a decrease in maximum engine gimbal angle as the pitch frequency increases. Since the maximum engine gimbal angle of the C-5 is approximately 4° , the vehicle would be restricted to operation in a 2σ design wind, at least for this simplified control system and for the estimated aerodynamics used. More sophisticated control systems could be designed that would require smaller engine gimbal angles. Another restriction on the selection of the pitch frequency is the desire to keep as large a separation as possible between the pitch frequency and the first flexible mode frequency in order to minimize coupling effects. Therefore, the next question is, what is the possible range of structural frequencies that might be obtained on such a configuration?

Vibration Characteristics of Launch-Vehicle—Space-Station

Combination

If the erectable structure consists of a number of long tubes, it will probably be mounted on the launch vehicle as shown in figure 1. This configuration is then essentially a cluster similar to the first stage of Saturn, as shown in figure 4. Dynamic tests of a 1/5-scale model of Saturn SA-1 have been made at the Langley Research Center, and some unusual mode shapes have been measured involving out-of-plane motion of the cluster tanks. Good agreement with full-scale test results has been obtained.

By utilizing experience with the model and modifying a calculation procedure which is being developed for the Saturn configuration, mode shapes and frequencies have been calculated for a clustered space-station configuration. Subsequent full-scale S-I vibration-test results have disclosed similar mode shapes. The several lowest modes of the configuration chosen for the stability and control study are shown in figures 5 and 6.

At the top of figure 5 is shown a cross section of a possible six-module space station. One of the major structural problems will be the method of attachment of the modules to the launch vehicle and to the hub. For this case, the attachment of each module to the top of the launch vehicle was assumed to be such that a cantilever boundary condition was obtained as indicated by the solid line and a pin-end condition obtained as indicated by the dashed line. A pin-end condition was assumed for each direction at the connection between the top of the module and the hub. These connections were assumed to be practicable for an erectable structure. The calculated frequencies for the lift-off weight condition are shown at the bottom of figure 5, and the mode shapes are shown in figure 6. Note that frequencies are listed for the two directions X and Y, and the small difference results from an assumed difference in weight distribution between some of the modules. The lowest frequency, 1.06 cps, is above the pitch-frequency range shown in figure 3 and is within the range of some frequencies for C-5 with other payloads. As a matter of fact, some preliminary data from the George C. Marshall Space Flight Center indicate first bending frequencies in the range of 0.7 to 1.0 cps for the lift-off condition for various C-5 configurations. In figure 6 are two mode shapes, first bending and third bending, as they would be seen in looking along the X-axis. Note that the space-station modules have an appreciable deflection even in the first mode and that the various modules are moving in the same direction, as shown by the cross section. The deflection of the space station in the third mode is even greater with respect to the launch vehicle. In this mode, however, the modules are vibrating unsymmetrically, some with large amplitude and some with small amplitude. This is due to both the unusual skewed end conditions and the differences in weight between some of the modules.

L
3
1
8
6

The proper end conditions for use in an analysis of a particular configuration will be difficult to determine, and experimental confirmation of the modes should be made, particularly in view of the presence of the deployment hinges which may force the modules to be rather close when installed on the launch vehicle and provide restraints in certain directions. Since dynamic models of appropriate launch vehicles will be constructed for vibration tests, a dynamic model of a space station may be constructed for testing on these models.

Summary

To summarize this frequency situation, in figure 7 frequency is plotted against time for the first $2\frac{1}{2}$ minutes of flight. Shown in this figure are the frequency variation of the first bending mode, a band indicating possible pitch-frequency range, and fuel-slosh frequency of the C-5. Note that the fuel-slosh frequency is well within the range

of the pitch frequency, and coupling is a definite possibility. Since over 90 percent of the mass of the vehicle is liquid, the stabilization of the large mass is difficult and is becoming more important as the vehicles become larger. The fuel-slosh frequency increases with time, since it is a function of longitudinal acceleration of the vehicle. The first bending mode appears to be well enough separated from the pitch frequency so that standard phase stabilization techniques may be employed. Thus it appears that, on the basis of this preliminary design-type analysis, a large clustered space station would be compatible with the future launch vehicles from the standpoint of stability and control.

HIGH-FREQUENCY ENVIRONMENT

Since the energy sources (the pulsations in engine thrust and the atmospheric disturbances) are randomly distributed in time, both the noise environment and the shock and vibration environments are essentially random processes. Some exceptions to this general rule do occur, and large periodic responses of the vehicle may arise for short periods of time when resonance occurs in the combustion chamber or when a large portion of the energy in the random spectrum is centered at the natural frequencies of lightly damped structural modes.

Buffet

An analytic estimation of buffet pressures around the forward portion of a launch vehicle is still not possible, and model testing is necessary. Recent wind-tunnel work on utilizing various scaled models is providing a better understanding of buffet scaling laws and a 1-percent model of a possible configuration is now being constructed for testing. In addition to measuring total forces and moments, six pressure cells for measuring oscillating pressures are located as shown in figure 8. Note that the pressure cells are located aft of the shoulders of the forward portion of the space station as well as along the modules; that is, in the regions of anticipated maximum buffet pressures.

Noise and Vibration Environment

The maximum noise levels anticipated around the top portion of the space station are shown in figure 9, where both the frequency content or spectrum in octave bands and the overall sound pressure level are plotted. These results are estimated on the basis of the anticipated performance and structure of the C-5 vehicle components and from an extrapolation of sound pressures measured on the S-1 vehicle. The most

severe noise levels would be encountered during flight at maximum dynamic pressure q_{MAX} . The associated sound pressure level gradually increases with frequency, peaks at approximately 157 decibels, and results in an overall sound pressure level of about 162 decibels. This spectrum is primarily caused by boundary-layer buildup and flow breakdown.

The fluctuating sound pressures around the vehicle result in sonic-induced vibrations at the top of the space station, which have been estimated and are presented in figure 10 as a function of frequency. The figure shows that systems components mounted in the upper portion of the vehicle would be subjected to high-frequency vibration at levels up to 8g, and illustrates the necessity of designing such systems so that their internal structural modes are adequately damped to avoid damaging conditions of structural resonance over a wide frequency band. For the abort case, levels as high as 30g are anticipated.

The noise and vibration levels shown in figures 9 and 10 may be used to study the response and fatigue of the vehicle structure, but their most immediate application is in the establishment of environmental criteria for testing the response and performance of the systems components and instrumentation within the vehicle. The use of such data is required for establishing type-approval and flight-acceptance test levels for systems which must be developed parallel with the vehicle structure, and for setting up necessary test equipment.

SOME SUPPORTING PROGRAMS

Some of the research programs in support of space-station technology are shown in figure 11.

1. As already indicated, a dynamic model of the C-5 configuration is being considered, and a space station could be installed and tested on this model with the use of the backstop now being constructed in the Langley Dynamics Research Laboratory, which is capable of handling vehicles as large as the Atlas.

2. With regard to the acoustic response of space-station structures, as mentioned earlier, the low-frequency range is of particular importance. To study problems in this range, the acoustic-response chamber will be utilized.

3. For studies of space-station deployment and systems, a 55-foot vacuum chamber will provide various combined environments as well as be useful for studying deployment problems. The equipment will be man-rated and thus can be used to study human operational problems.

4. A continuation of basic research studies to determine the effects of extreme environment on structural components will be pursued in the extreme-environment chamber, where panels and other elements can be subjected to large variations in temperature, vacuum, and vibration, including the use of a 2,000-pound shaker.

5. Basic research in appropriate wind tunnels will be continued to better define the anticipated buffet conditions and to clarify the aerodynamics appropriate to stability and control analyses.

L
3
1
8
6

CONCLUDING REMARK

Some of the advanced technological areas that are being worked on in support of the space station have been discussed, and it has been shown that some space-station configurations will be compatible with the C-5 launch vehicle from the standpoint of control and dynamics.

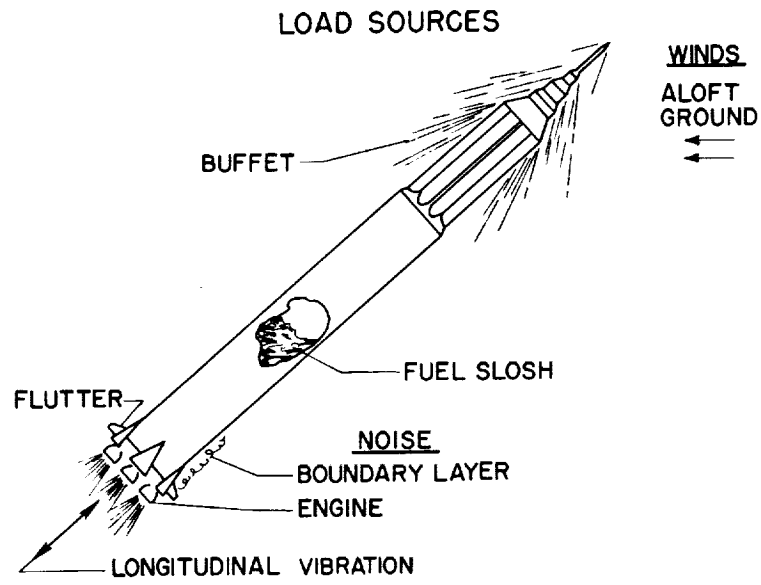

Figure 1

CONTROL AND STABILITY SYSTEM

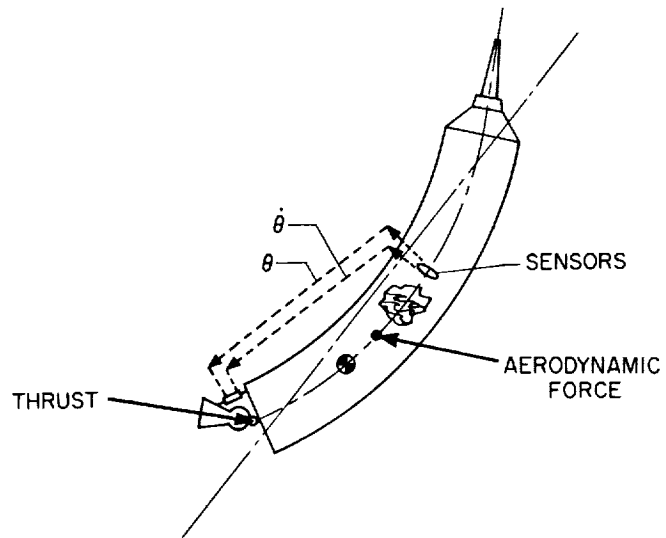

Figure 2

VARIATION OF MAXIMUM ENGINE GIMBAL ANGLE WITH PITCH FREQUENCY

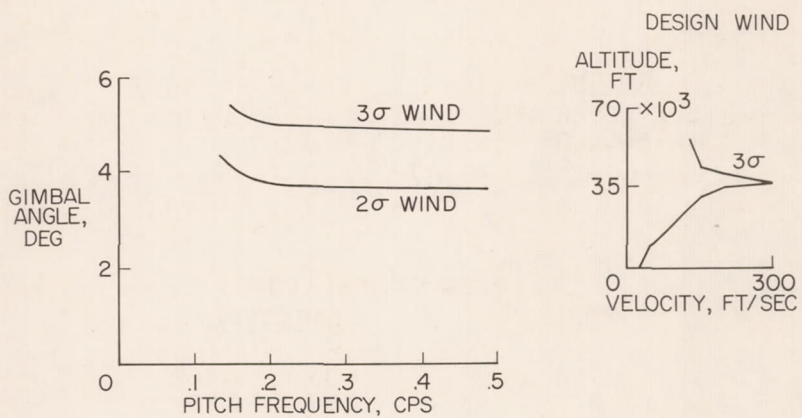

Figure 3

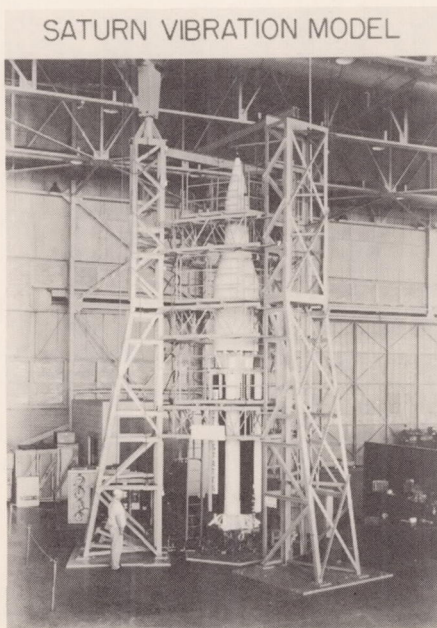
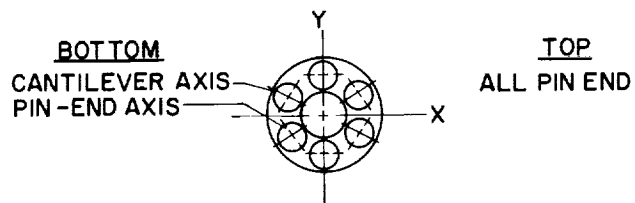

Figure 4 L-61-4079.1

CALCULATED LATERAL MODES OF SPACE-STATION-LAUNCH-VEHICLE COMBINATION



FREQUENCIES, CPS

MODE	DIRECTION	
	X	Y
1	1.06	1.062
2	2.98	2.99
3	4.53	5.55
4	6.22	6.41

Figure 5

CALCULATED LATERAL MODE SHAPES OF SPACE STATION AND LAUNCH VEHICLE

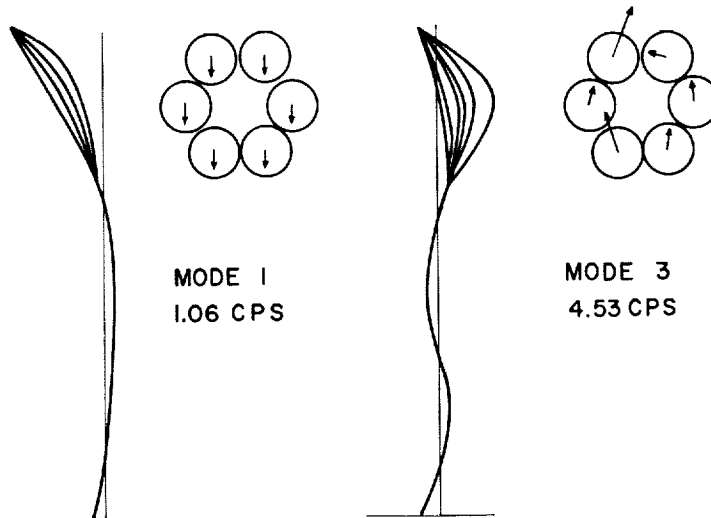

Figure 6

FREQUENCY VARIATION WITH FLIGHT TIME

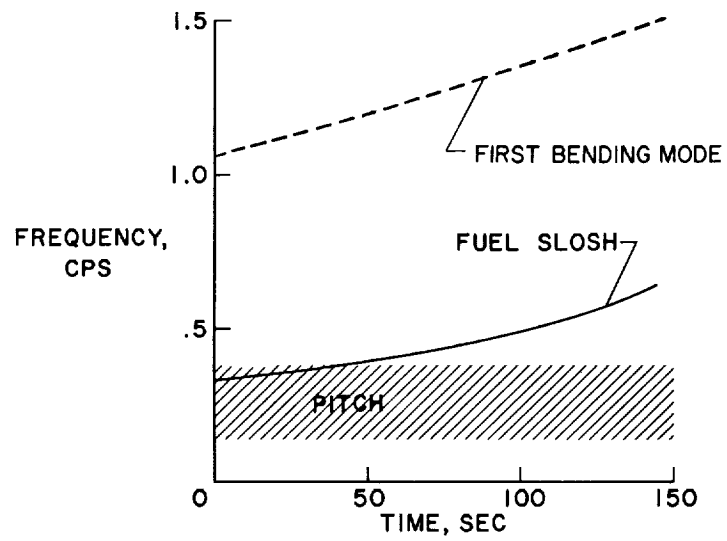

Figure 7

BUFFET MODEL

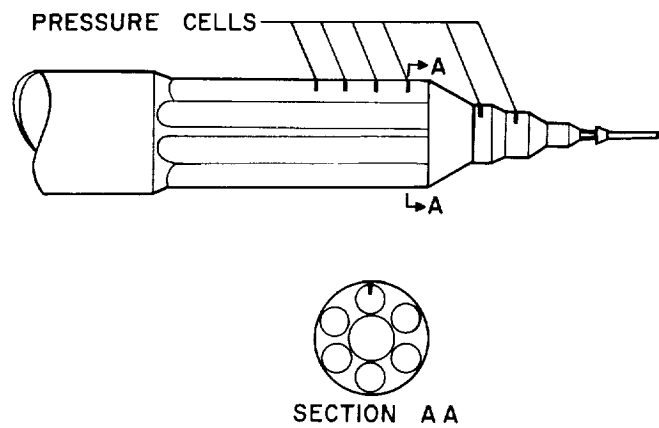

Figure 8

AERODYNAMIC NOISE PRESSURE LEVELS AROUND SPACE STATION AT q_{MAX}

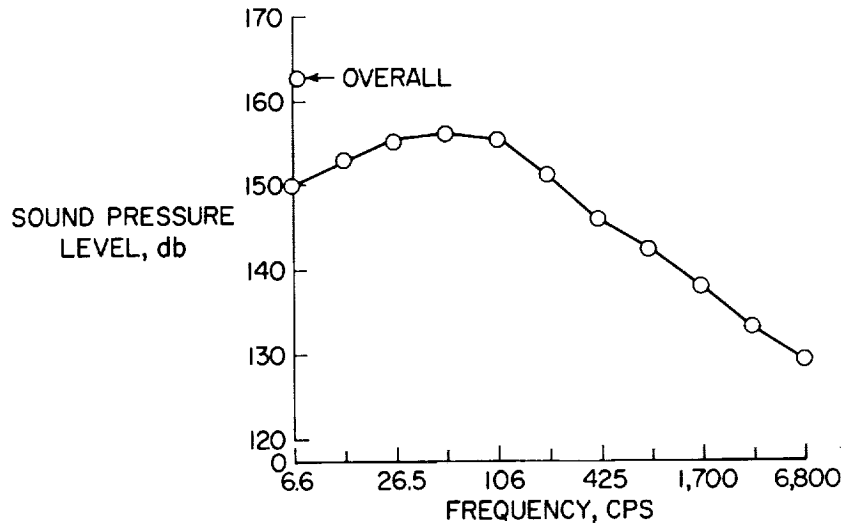

Figure 9

ESTIMATED MAXIMUM SONIC-INDUCED VIBRATION OF SPACE STATION AT q_{MAX}

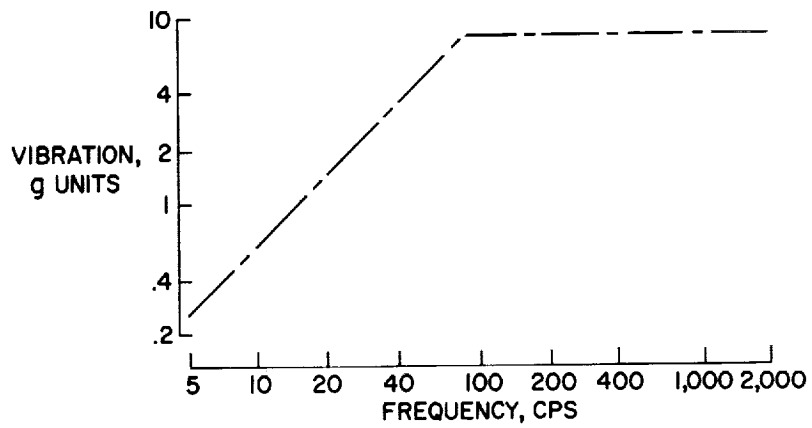
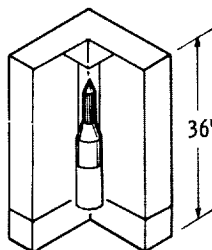

Figure 10



RESEARCH PROGRAMS IN SUPPORT OF SPACE-STATION TECHNOLOGY

1. VIBRATIONS OF DYNAMIC MODELS OF LAUNCH CONFIGURATIONS



2. ACOUSTIC RESPONSE OF SPACE-STATION STRUCTURES

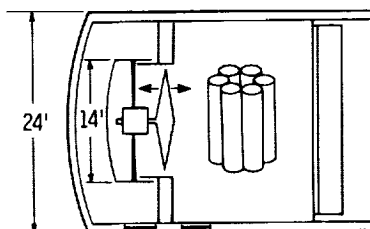

3. SPACE-STATION DEPLOYMENT AND SYSTEMS STUDIES

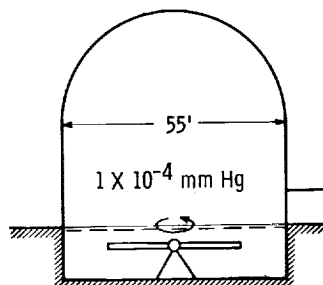

4. EXPERIMENTAL EVALUATION OF THE EFFECT OF EXTREME ENVIRONMENTS ON STRUCTURAL RESPONSE

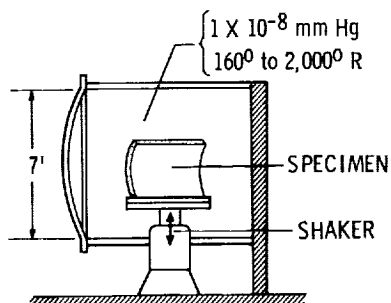

5. BUFFET-MODEL TESTS AND STABILITY AND CONTROL ANALYSES

Figure 11

12. CREW PERFORMANCE ON A LUNAR-MISSION SIMULATION

By Joseph S. Algranti, Donald L. Mallick,
and Howard G. Hatch, Jr.

SUMMARY

L
3
1
8
5
In order to study the performance of a crew in prolonged space flight, a simulation of a lunar-landing mission was made. Three trained test pilots performed realistic duties during simulations of three missions. The areas evaluated include: duty cycles, physical conditioning of crew members prior to and during the mission, crew proficiency in normal mission duties, and crew alertness to emergency situations. The study showed no difficulties with test-pilot personnel for confinement periods up to 7 days. It was found that a 26-hour duty cycle with two 4-hour sleeping periods was suitable for a three-man crew on a 7-day mission, and that there was no decrement in performance resulting from the long mission time. Because of the onboard exercise program, there was no deterioration of physical condition, and the pilots' alertness remained high throughout the mission.

INTRODUCTION

One of the many difficulties facing the crews on future space flights is the length of time required for mission completion. Even for the simplest circumlunar mission of the ballistic free-fall type, flight times of about 7 days are required. Round-trip missions to the nearest planets require many months or years of flight time with presently available propulsion systems. And, of course, space stations will have the capability of remaining indefinitely in orbit about the earth. In addition to the time element, some difficulties may arise as a result of the small volume available for working and living quarters and the reduced sensory-input environment. It has been suggested that these factors may pose both physiological and psychological problems for the crew. Some studies of the effect of "sensory deprivation" have been made, and the findings of these studies have been extended as being pertinent to the conditions of space flight. However, doubt may be cast on extending the findings of these studies to future space flights for three reasons: first, the nonrealistic environment utilized in most of the studies; second, the lack of any criteria for selecting the subjects; and third, the performance of duties which are not applicable to space missions.

In order to obtain data from a study not subject to these criticisms, the National Aeronautics and Space Administration has conducted a detailed

realistic real-time task simulation to determine the effects of long-time missions and confinement on the performance of crew members.

A crew of three trained test pilots performed realistic duties during analog simulation of the dynamic phases of a circumlunar flight. Difficult tasks, such as lunar landing, orbit rendezvous, and reentry were performed after $3\frac{1}{2}$ - and 7-day missions. The areas studied were:

- (1) Evaluation of duty cycles
- (2) Physical conditioning of the crew prior to and during the mission
- (3) Crew proficiency in normal mission duties
- (4) Crew alertness to emergency situations

L
3
1
8
6

MISSION PROFILE

The particular mission simulated was a lunar mission, but the findings are of significance to any manned space-flight operation, such as an orbital space station. The complete lunar-mission profile which involves all phases of the flight is shown in figure 1. In the study to be discussed, there were three missions. The first two missions started with launch from earth and terminated with ascent from the lunar surface and return to lunar orbit - that is, phases 1 through 7. These were $3\frac{1}{2}$ -day missions and were mostly a continual evaluation of many factors, such as duty cycles and different exercise programs. The information gained on the first two missions was applied on the third flight, a full 7-day study which included all the phases shown in figure 1.

Two approaches to the lunar-landing mission were considered: first, a direct landing in which the entire approach vehicle lands on the moon; and second, the use of a lunar-excursion vehicle or "bug." In the latter case, the command module remains in lunar orbit, and the landing is made by one man in the bug. This latter mode involves a lunar rendezvous when the bug returns to the command module. A schematic of details of the mission in the vicinity of the moon is shown in figure 2. The normal landing and ascent trajectories are indicated.

Reentry is another critical phase of the lunar mission. Details of the nominal reentry trajectory are shown in figure 3. This is a long-range trajectory, and the pilot must be extremely careful in controlling the velocity conditions at skip-out altitude in order to obtain the

desired longitudinal range, which, in this case, is 5,900 miles. In fact, an error of 1 foot per second in altitude rate at this point produces a longitudinal-range error of 10 miles.

Pilot performance on lunar landing, rendezvous, and reentry was evaluated by comparison of pre-experiment or base-line runs with results obtained on the simulated missions.

The crew duties during the various missions are outlined as follows:

- (1) Flight-control duties:
 - (a) Launch and ascent
 - (b) Midcourse correction
 - (c) Orbit insertion
 - (d) Lunar landing, ascent, and rendezvous
 - (e) Reentry and landing

- (2) General system and mission duties:
 - (a) Management of onboard data records
 - (b) Onboard maintenance
 - (c) Navigation
 - (d) Systems checks
 - (e) Log checks
 - (f) Monitoring of onboard systems

- (3) General psychological tasks:
 - (a) Time estimation
 - (b) Reaction time

The primary duty is, of course, to fly the various phases of the mission as closely as possible to the nominal paths and to attain acceptable landing conditions at the moon and the earth. In addition, there are other duties which include two psychological tasks which were done twice a day by each crew member.

PHYSICAL EQUIPMENT

The physical equipment used in the study was the Martin Marietta Corporation (Baltimore Division) lunar-mission simulator with the Langley Research Center one-man bug attached. An overall view of the simulator is shown in figure 4. The bug is attached to the spacecraft by a tunnel just large enough to permit a man to crawl through. The main vehicle is an Apollo-type command module with a maximum diameter of 160 inches. It has three-abreast seating for commander, navigator, and systems engineer; the general arrangement allows for an off-duty area, a sleeping area, and a sanitation area. The crew members spent the entire mission time

enclosed in the spacecraft except for tasks involving the bug. A view of the three-man crew on station in the main vehicle is shown in figure 5. The large instrument panel with most of the gages functional creates a realistic environment.

The commander, in the left seat, flew the module by means of a side-arm controller; the navigator, in the center seat, assisted by monitoring backup displays and ran the clocks and timers; and the engineer, in the right seat, monitored and controlled propulsion, electrical, and environmental-control systems.

The simulation instrumentation, communications, and controls are run from the control room shown in figure 6. The spacecraft and bug controls were linked to the analog computer, which computed the vehicle motion and generated displays during the mission.

L
3
1
8
6

CREW SELECTION AND PREFLIGHT TRAINING

As mentioned in the introduction, in some of the former confinement studies in which physiological or psychological problems have been encountered, there were few or no criteria for personnel selection. Consequently, some of the subjects were in poor physical condition and had no real motivation for good task performance. This is in contrast to what is expected of a trained astronaut crew. Results obtained with these untrained subjects have, in some cases, been quite unexpected in that the subjects had hallucinations, muscular pains, and other effects. Unfortunately, the publicity awarded these results has cast certain doubts on man's ability to perform well in confined areas over prolonged periods.

In order to approach this problem area more realistically, the four crew members participating in the NASA-Martin experiment were all NASA pilots, presently assigned to three different NASA centers. These pilots were mature, experienced, and well-motivated test pilots; their average age was $34\frac{1}{2}$ years and their average flight time was about 4,000 hours; each had flown at least 40 different types of aircraft. Three of the pilots comprised the actual crew while the fourth acted as primary capsule communicator. No compatibility tests were used in crew selection.

Orientation and training of the crew, particularly in the dynamic flight phases, was comprehensive and extended over a period of about $3\frac{1}{2}$ months. There was also a physical training program, aimed at providing good physical condition, muscle tone, and endurance, prior to the confinement periods. This program which consisted of calisthenics, running, and some weight lifting was formulated and directed by a professional physical therapist.

DUTY CYCLE

The 24-hour duty cycle used on mission I, shown at the top of figure 7, consists of an 8-hour sleep period and a 16-hour wake period. The pilots found the last few duty hours of the 16-hour wake period very tiring. Eye fatigue was noticeable and general boredom set in from long hours of panel monitoring. Because of eye fatigue and boredom, the pilot found it difficult to focus his eyes on one spot and very easy to stare at the panel - looking but not really seeing. In addition, the pilots were unable to sleep the full 8 hours, and became tired after 2 nights of very little sleep. Some of the reasons suspected are:

- (1) Noises associated with simulator:
 - (a) Communications: crew-to-ground and crew-to-crew
 - (b) Warning horns
 - (c) Air-conditioning compressor
 - (d) Movement of crew members about the spacecraft
- (2) Variations in temperature
- (3) Uncomfortable and restricted sleeping area.

The average uninterrupted sleep was 4 hours with the remaining 4 hours spent catnapping or trying to sleep. Because of this unsatisfactory sleeping situation, a second duty cycle was adopted for mission II. The primary difference between this duty cycle and duty cycle I was the splitting of the 8-hour sleep period into two 4-hour periods with a 9-hour wake period in between. This results in a 26-hour day. The pilots were in unanimous agreement that duty cycle II was very good and thought that it could be used over long periods of time. Duty cycle II therefore was utilized in the 7-day mission and again proved to be entirely satisfactory. The pilots were able to sleep 4 hours after being awake for about 9 hours, and they did not experience the degree of boredom associated with duty cycle I.

ONBOARD EXERCISE PROGRAM

For onboard maintenance of muscle tone during the simulated space missions, the pilots used a bungee-type device which incidentally would be practical under zero "g." There were four 15-minute exercise periods each day on the first mission. This program was carried on throughout the mission, but on completion of the mission, the crew members decided it would be desirable to exercise more frequently for a shorter period of time. On mission II, therefore, a 5-minute exercise period was planned for every off-duty period. This was carried out for the first half of

mission II at which time the crew suggested a change to 5 minutes of exercise in alternate off-duty periods. This third cycle was agreed to by the program director and proved to be satisfactory. This cycle of 5 minutes every other off-duty period was used during the 7-day mission. This exercise program was not strenuous enough to cause any great increase in appetite and the planned 1,800-calorie diet was sufficient throughout the mission.

A brief physical-condition evaluation made prior to and after each mission showed no apparent degradation of condition resulting from reduced activity in the confined area. The main evaluation was based on the Harvard Step Test; blood pressure, pulse, and blood samples were taken prior to and after each of these strenuous tests. The blood samples were analyzed for steroids level. Blood steroids level is a stress indication and will be discussed in more detail in the following section. There were no complaints of any discomfort such as back pain or leg weakness that had been encountered on other simulations. The crew members in this study showed no noticeable effect of even the 7-day mission.

L
3
1
8
6

TASK PERFORMANCE

Crew performance during the dynamic flight phases was measured and compared with base-line data obtained during the preflight training period. The most difficult tasks were the lunar landings, lunar ascent and lunar orbit rendezvous, and reentry. It should be remembered that the lunar landings were made after $3\frac{1}{2}$ days of mission time and reentry after 7 days. Some comparison of preflight and flight data for the vertical touchdown velocity for lunar landings, docking rates on rendezvous, and altitude-rate error on skip-out are shown in table I. It is, of course, desirable to have low touchdown velocity, low docking velocities, and a low value of altitude-rate error on the first skip-out during reentry. Two points of interest are shown: first and most important for this study, there is no degradation in pilot performance resulting from the long mission times involved. As a matter of fact, the pilots' performance of the critical tasks was better after the confinement period. This is probably attributable to greater pilot motivation during actual missions. The second point of interest is that the vertical touchdown velocity is low enough to be acceptable for lunar landings. Actually, the ability of the pilots to obtain low impact velocity was determined more by readout limitations of the indicators than by piloting capability. Other data, comparing task performance during preflight base-line measurements with performance of the same tasks after a long duration of mission time, also showed no noticeable pilot degradation.

Because of the critical nature of certain phases of the lunar mission, it was believed that the pilots would be under stress. For this reason, an analysis was made of the hydroxy-ketosteroid levels of the pilots' urine throughout the missions. The steroids are a reliable indicator of stress and represent the breakdown of adrenal products that are introduced into the blood stream during periods of physiological and psychological stress. These steroids levels vary diurnally. This diurnal variation is evident in figure 8, in which the steroids level is plotted as a function of time for mission I. If it were surmised that the confinement itself was a producer of stress, the steroids levels should show a gradual rise with the elapsed mission time. Actually, there is no measurable difference between the base-line levels for 48 hours before the mission and the levels at the end of the $3\frac{1}{2}$ -day mission.

Pilot alertness, as indicated by the ability to cope with emergency situations, showed no deterioration with confinement. When situations requiring aborts or onboard maintenance were encountered, the pilots immediately recognized them and followed proper procedures.

During the missions, the pilots sometimes tended to forget momentarily certain procedures for performance of tasks. It is believed that more intensive training, as would certainly apply prior to actual missions, would remove this tendency.

CONCLUDING REMARKS

This simulation study has shown no difficulties with test-pilot personnel for confinement periods up to 7 days. It was found that a 26-hour-duty cycle with two 4-hour sleep periods was suitable for a three-man crew on a 7-day mission, and that there was no decrement in performance resulting from the long mission time. Because of the onboard exercise program, there was no deterioration of physical condition, and pilots' alertness remained high throughout the mission.

Langley Research Center,
National Aeronautics and Space Administration,
Langley Station, Hampton, Va., August 1, 1962.

TABLE I

COMPARISON OF PREFLIGHT AND MISSION DATA

LUNAR LANDING (DIRECT)

	RATE OF DESCENT, FPS	SUM OF ANGULAR RATES
BASE LINE	6.78	1.03
MISSION I	6.53	.76

RENDEZVOUS DOCKING RATES

	\dot{x} , FPS	\dot{y} , FPS	\dot{z} , FPS
BASE LINE	0.95	0.76	1.23
MISSION II	.73	.44	1.15

ALTITUDE-RATE ERROR ON SKIP-OUT

	FPS
BASE LINE	1.4
MISSION III	.5

MISSION PROFILE

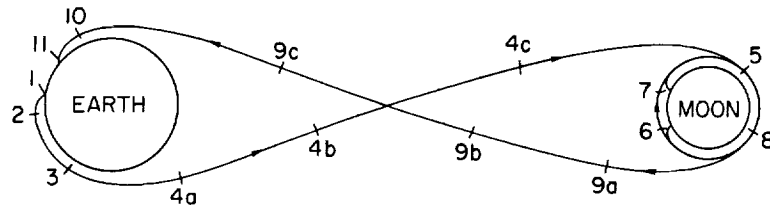

- | | |
|--|--------------------------------|
| 1 LAUNCH | 6 DESCENT FROM ORBIT |
| 2 ESTABLISHMENT OF ORBIT | 7 RETURN TO ORBIT |
| 3 INJECTION INTO EARTH-MOON TRAJECTORY | 8 INJECTION, MOON-EARTH |
| 4(a,b,c) MIDCOURSE CORRECTIONS | 9(a,b,c) MIDCOURSE CORRECTIONS |
| 5 ATTAINMENT OF LUNAR ORBIT | 10 REENTRY |
| | 11 RECOVERY |

Figure 1

TRAJECTORIES IN VICINITY OF THE MOON

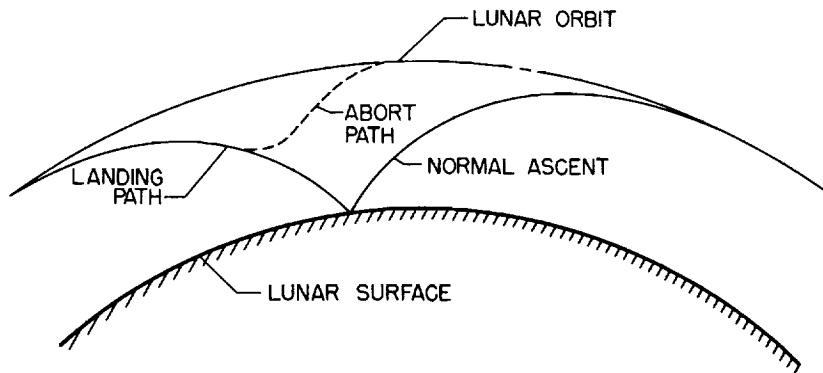

Figure 2

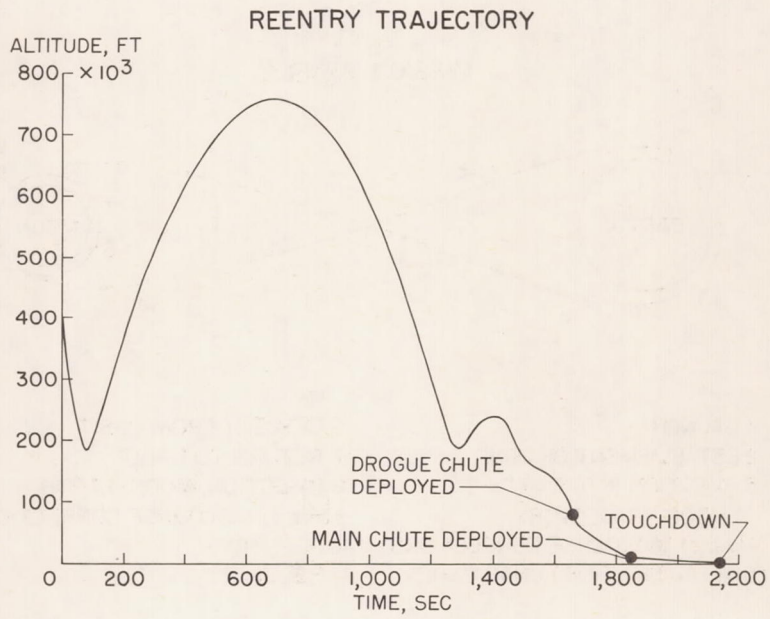

Figure 3



Figure 4

L-62-1022



Figure 5

L-62-1023



Figure 6

L-62-1024

DUTY CYCLES

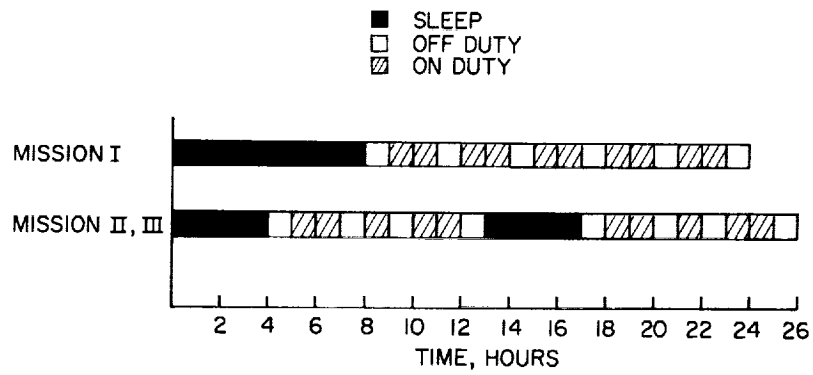

Figure 7

STEROIDS LEVEL

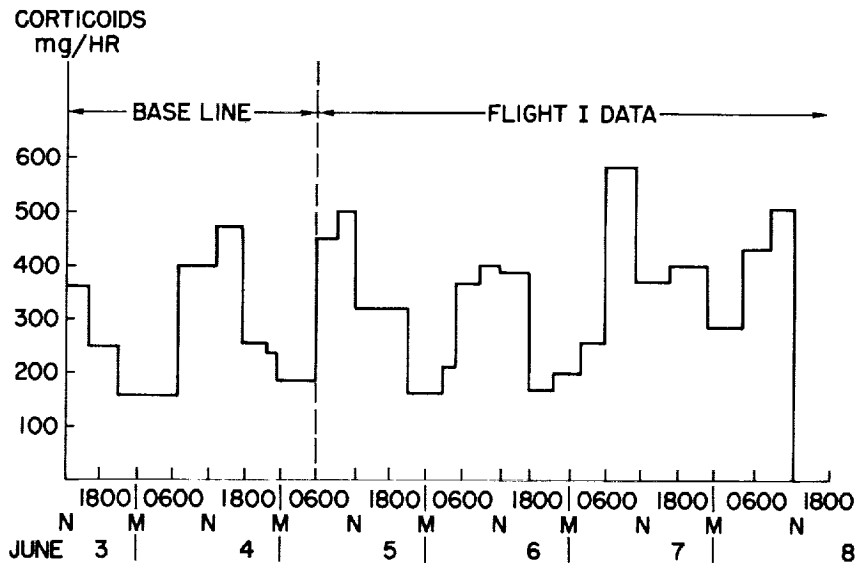

Figure 8