

554008 1485

125

NASA TN D-1597

NASA TN D-1597

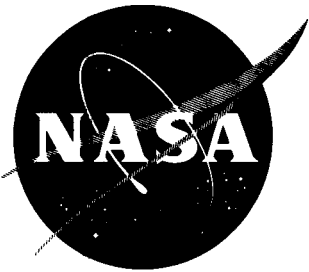

N63-11619
Code 1

TECHNICAL NOTE

D-1597

THE USE OF AN IONIZATION GAGE AS A QUANTITATIVE ANALYZER
FOR BI-GASEOUS MIXTURES

By Leonard T. Melfi, Jr., and George M. Wood, Jr.

Langley Research Center
Langley Station, Hampton, Va.

NATIONAL AERONAUTICS AND SPACE ADMINISTRATION
WASHINGTON

December 1962

NATIONAL AERONAUTICS AND SPACE ADMINISTRATION

TECHNICAL NOTE D-1597

THE USE OF AN IONIZATION GAGE AS A QUANTITATIVE ANALYZER
FOR BI-GASEOUS MIXTURES

By Leonard T. Melfi, Jr., and George M. Wood, Jr.

SUMMARY

The inherent difference in the relative ionization of helium and air has been utilized as a means of quantitatively measuring the percentage composition of helium-air mixtures. The technique will find application in facilities requiring multichannel analysis of any bi-gaseous mixtures which have sufficient differences in relative ionization.

Upon the completion of laboratory testing, the gas analyzer was successfully field tested in conjunction with a project in which mixture compositions from 0- to 100-percent helium were measured from a number of survey points in a supersonic stream.

INTRODUCTION

In the past, the problem of gas analysis in test facilities has been solved by the use of analyzers whose capabilities for acquiring rapid sampling and large amounts of data were sacrificed for high sensitivities and component identification. An increasing need has been noted for a simplified quantitative instrument, capable of quickly sampling and recording data from many sample points, for use in facilities whose operating costs do not permit extremely long runs, and whose test conditions do not require extreme accuracies. This report describes the design, development, and testing of such an analyzer.

All of the many commercially available methods of analysis such as gas chromatography, mass spectrometry, and thermal conductivity were discarded for reasons of the time required for sampling, the difficulty in maintaining constant flows, or limited sampling ability. The method of collecting samples in bottles from many points for analysis by mass spectrometry has been used at other research centers. The method was not applicable in this case because of extensive data-handling capabilities desired.

After investigating the various methods of analysis mentioned above, it became apparent that a new approach should be taken to the problem. An initial system was designed to determine mixture composition by comparing the pressures indicated by an ionization pressure gage with those of a gage that is insensitive to gas

composition. This approach involved recording the outputs of two gages for each channel and applying this information to an equation. Extensive computations and data reduction were required and resulted in reduced accuracy and increased man-hour consumption. To overcome the limitations of the preliminary analyzer, a more versatile system fulfilling the analysis requirements and, at the same time, materially reducing the data-gathering and reduction problems, was needed. The ratio of the output of the two gages is proportional to the mixture composition and is independent of the pressure; therefore, by measuring the ratio of the outputs, a direct reading, quantitative gas analyzer was developed.

SYMBOLS

| | |
|--------------|--|
| O_{α} | output of the Alphasatron for any mixture |
| O_x | output of the Alphasatron for 100-percent carrier gas |
| P_t | total pressure |
| P_x | partial pressure of carrier gas |
| P_y | partial pressure of sample gas |
| S_x | pressure sensitivity of the Alphasatron to carrier gas |
| S_y | pressure sensitivity of the Alphasatron to sample gas |
| x | volumetric fraction of carrier gas |
| y | volumetric fraction of sample gas |

THEORY

As is true of all ionization gages, the Alphasatron is gas-composition sensitive. However, the relative sensitivity for pure gases, or known mixtures, is predictable. If the gage is considered to have a linear output with pressure for each gas, then the pressure sensitivity for helium would be 21 percent; hydrogen, 25 percent; water vapor, 86 percent; and carbon dioxide, 150 percent of that for dry air (ref. 1).

Once the sensitivity for any two gages is known, the sensitivity of any mixture of the gases can be calculated. From Dalton's law the sum of the partial pressures by volume is equal to the total pressure or

$$P_t = P_x + P_y \quad (1)$$

and

$$x = \frac{P_X}{P_t}; y = \frac{P_Y}{P_t} \quad (2)$$

where x and y are the fraction by volume of the carrier and sample gas, respectively. If the total ionization current is assumed to be the sum of the current due to each fraction, then

$$O_\alpha = S_x P_X + S_y P_Y \quad (3)$$

substituting equation (2) into equation (3)

$$O_\alpha = (xS_x + yS_y)P_t \quad (4)$$

dividing by O_x ,

$$\frac{O_\alpha}{O_x} = \frac{(xS_x + yS_y)P_t}{O_x} \quad (5)$$

but by definition, when $P_X = P_t$,

$$O_x = S_x P_t$$

Thus equation (5) becomes

$$\frac{O_\alpha}{O_x} = \frac{xS_x + yS_y}{S_x} \quad (6)$$

and

$$\frac{O_\alpha}{O_x} = x + y \frac{S_y}{S_x}$$

but in a bi-gaseous mixture $x + y = 1$; therefore,

$$\frac{O_\alpha}{O_x} = 1 - y + y \frac{S_y}{S_x} \quad (7)$$

or

$$y = \frac{1 - \frac{O_\alpha}{O_x}}{1 - \frac{S_y}{S_x}} \quad (8)$$

This expression gives the fraction of sample gas y as a linear function of O_{α}/O_x , which is the ratio of the Alphasatron outputs in the mixture and in the 100-percent carrier gas. Therefore, if a gage which is not sensitive to gas composition is calibrated to give O_x and the Alphasatron is used to measure O_{α} , O_{α}/O_x may be obtained by the use of a ratio meter. It should be noted that there are no pressure or output terms in the right side of equation (7), and therefore theory establishes the independence of pressure.

DESCRIPTION OF ANALYZER

The apparatus consists of an ionization pressure gage, a diaphragm pressure gage, a ratio meter, and associated power supplies.

The chief component of the analyzer is the National Research Corporation "Alphasatron" ionization gage. The Alphasatron (ref. 2) replaces the filament found in the more usual ionization gages with a small radium 226 source. Alpha particles emitted from this source ionize the gas molecules, which are collected on a charged plate, and produce an ionization current of 10^{-11} to 10^{-13} amperes. An electrometer amplifier is provided to bring these small currents to a useful level. Elimination of the filament makes the Alphasatron particularly suited to this application, as the gage may be subjected to atmospheric pressure without danger of burnout. The particular Alphasatron used for this test is a version modified for the NASA (known as the "NASA Model") and has a linear range of 0 to 30 torr (1 torr is defined as 1/760 of a standard atmosphere by the International Organization for Standardization).

The diaphragm gage used during the test was a 0- to 50-torr transducer (ref. 3). This gage consists of strain gages forming a four-arm Wheatstone bridge and is actuated by a thin diaphragm. As the pressure changes, the diaphragm is deformed, and places the bridge in a state of unbalance which results in an output of 0 to 10 mv.

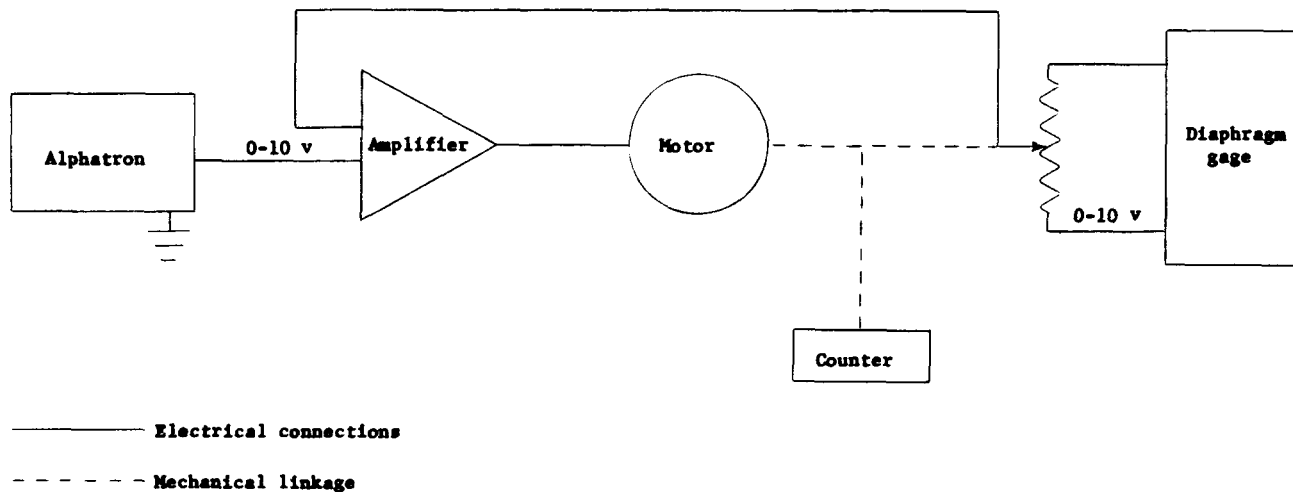

Figure 1.- Ratio meter.

The ratio meter (fig. 1) is a null-seeking servosystem designed and constructed at Langley Research Center. The Alphasatron output O_{α} is fed into a servoamplifier which drives a motor changing a reference potentiometer across which the diaphragm-gage output O_x is applied. A feedback loop connected to the potentiometer causes the motor to run until the servomotor is balanced. A counter is linked to the shaft of the motor which gives a visual display of the ratio of the two signals (ref. 4).

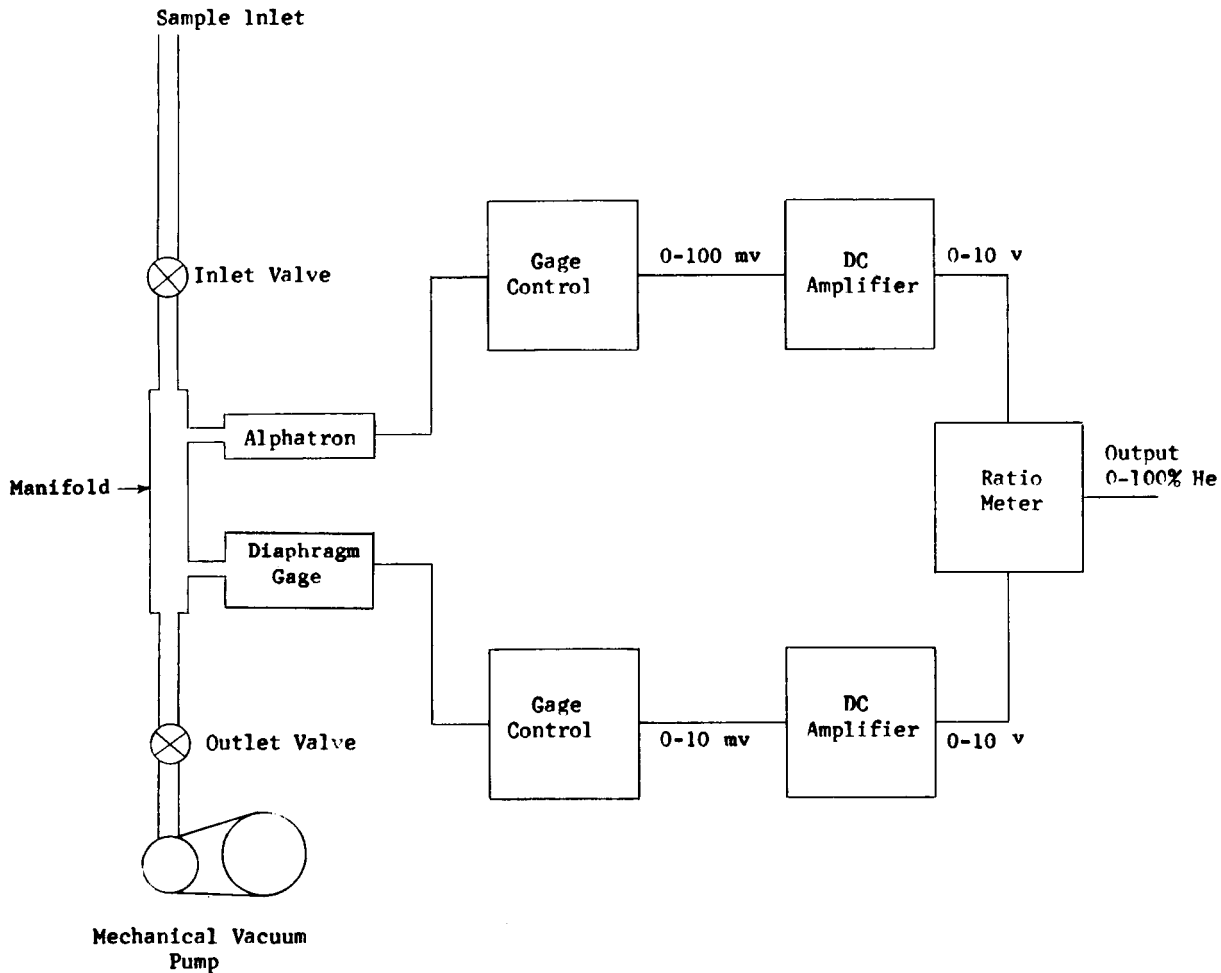

Figure 2.- Single-channel gas analyzer.

The components described were assembled as shown in a block diagram (fig. 2). The gages are attached to a brass manifold, which was drilled larger than the small-diameter connecting tubing to provide a momentary reduction in flow velocity. Inlet and outlet throttle valves are provided to maintain the pressure in the manifold within the operating range of the gages. Sample flow is maintained throughout by a mechanical vacuum pump.

The output of the gages are fed into d-c amplifiers to equalize the voltages presented to the ratio meter. A sufficiently high level of amplification is utilized to realize optimum performance and to minimize interference.

LABORATORY EVALUATION

In order to analyze helium-air mixtures, an Alphasatron was calibrated (fig. 3) in these two media, and S_y/S_x was determined to be 0.21 over the pressure range of the instrument. These data agreed with those presented in the literature (ref. 1). By substituting $S_y/S_x = 0.21$ in equation (7), O_a/O_x was calculated for different percentages of helium. These values are presented in the following table and in figure 4:

| y | | O _a /O _x |
|------|-------|--------------------------------|
| 1.00 | | 0.210 |
| 0.95 | | 0.250 |
| 0.90 | | 0.289 |
| 0.75 | | 0.407 |
| 0.50 | | 0.605 |
| 0.25 | | 0.802 |
| 0.00 | | 1.000 |

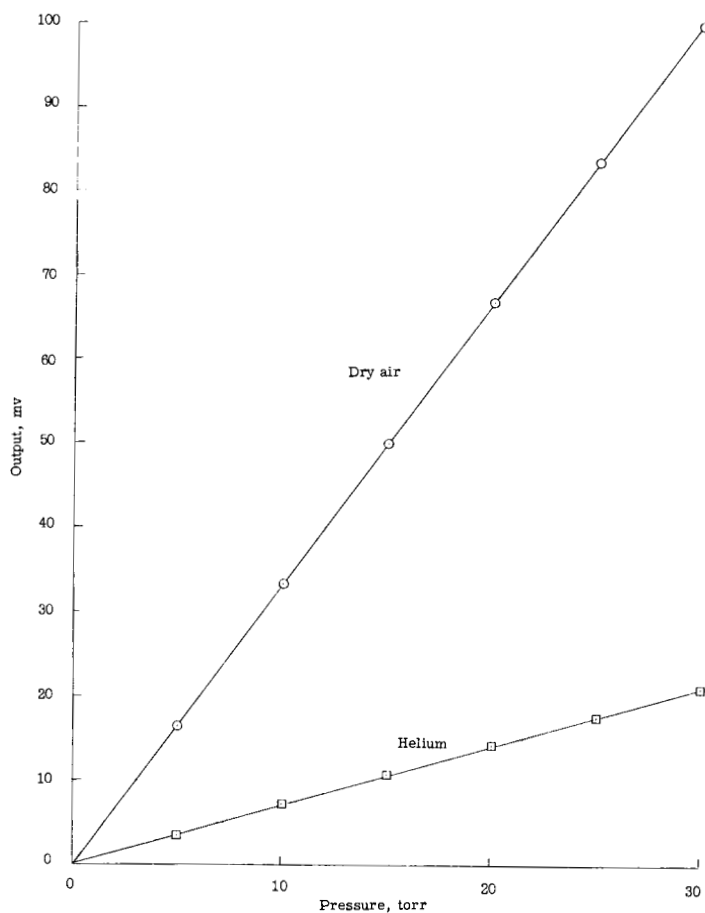

Figure 3.- Alphasatron calibration.

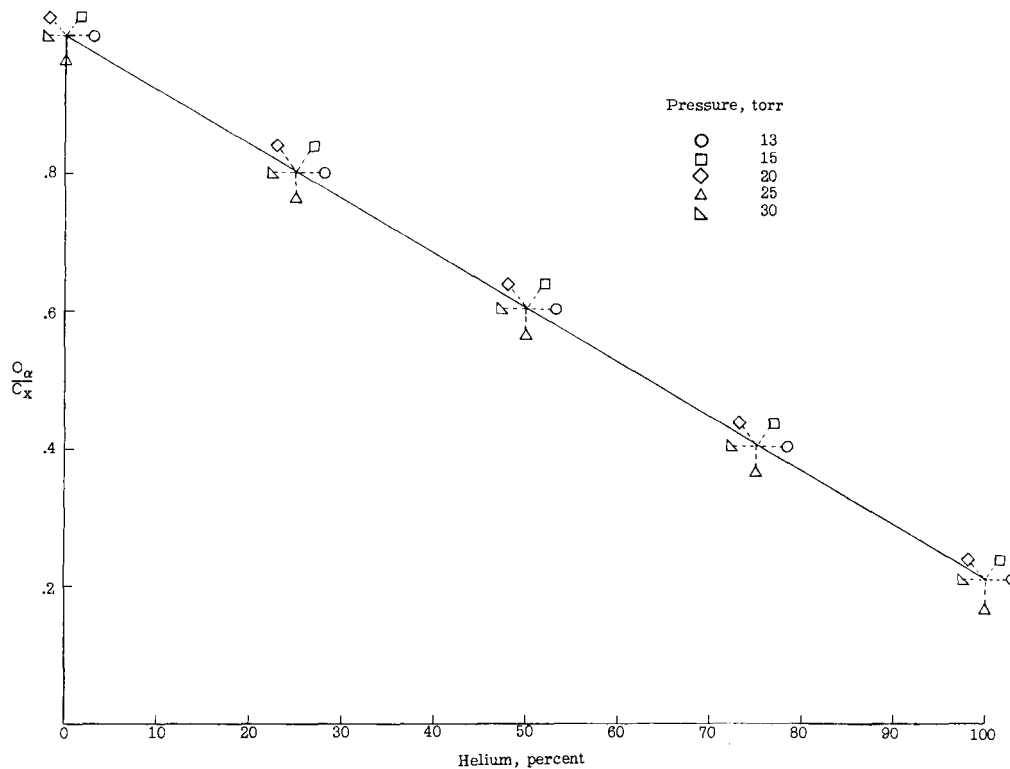

Figure 4.- Calibration curve.

The diaphragm gage was adjusted so that its output corresponded to the output of the Alphatron in dry air; then this gage was used to obtain the carrier output O_x . The ratio of the outputs O_{α}/O_x of these gages should then be proportional to the percentage of helium and should lie on the theoretical curve (fig. 4).

In order to check this phenomenon, a mixture of 25-percent helium in air was obtained by employing Dalton's law of partial pressures, checked by a mass spectrometer, and connected to the sample inlet (fig. 2). By adjusting the inlet and outlet valves, a constant flow at a given pressure was maintained through the analyzer. The O_{α}/O_x value was obtained from the output of the ratio meter and compared with the calculated O_{α}/O_x curve (fig. 4). This test was repeated for mixtures of 50-percent, 75-percent, and 100-percent helium. At each of these points, the pressure was varied from 13 to 30 torr to assure that the ratio remained constant and independent of the pressure. The total deviation from the predicted value did not exceed ± 0.3 percent. Figure 5 shows the largest variation with pressure at 0-percent helium. The deviations were found to be due primarily to the nonlinearity of the diaphragm gage.

The analyzer which resulted from these studies has the capability of rapidly analyzing any bi-gaseous mixtures. Optimum sensitivity is obtained when the gases have a large difference in relative ionization. If either of the gages is nonlinear, accurate results may still be obtained by matching the mean slopes of their calibration curves over a reduced pressure range.

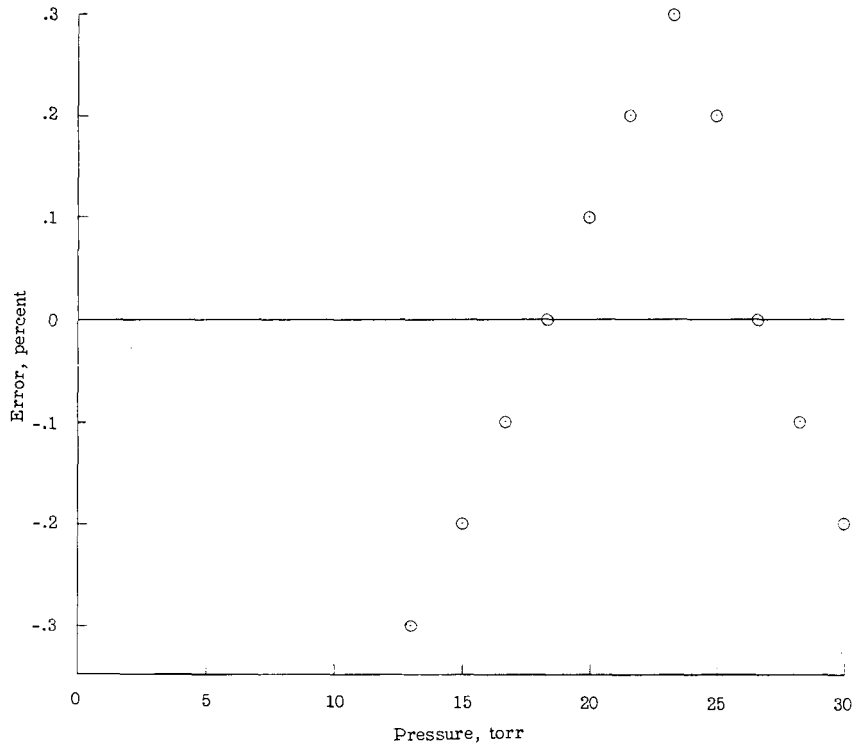

Figure 5.- Deviation curve; zero-percent helium.

EXPERIMENTAL APPLICATION

Following the completion of laboratory tests and evaluation, a 15-channel version of the analyzer was installed in Langley Unitary Plan wind tunnel for the following application.

The use of liquid hydrogen as rocket-engine fuel requires that a vent be provided to release vaporized hydrogen during flight. The design configuration and location of the vents must be such as to prevent concentrations of hydrogen in the vicinity of the burning lower stages. Investigation of this problem included the ejection of a gas into a supersonic stream at various mass flows through a number of vent configurations. Helium was substituted for hydrogen for safety considerations. The test required that a large number of varied helium-air flow patterns be established by means of a 15-channel survey rake.

The basic unit (fig. 2) was expanded (figs. 6 and 7) to meet this requirement by placing 15 inlet and outlet throttling valves in a compact unit to maintain the pressure within 10 to 30 torr, and by manifolding the outlets to permit the use of a single vacuum pump. Solenoid valves were included in each channel to permit isolation from the tunnel. Since there was only one ratio meter available at the time, it was necessary to include a channel selector, designed to place the outputs from each channel, in sequence, to the input of the ratio meter. A shaft digitizer was connected to the ratio meter servomechanism to enable recording of the data on a punchcard system.

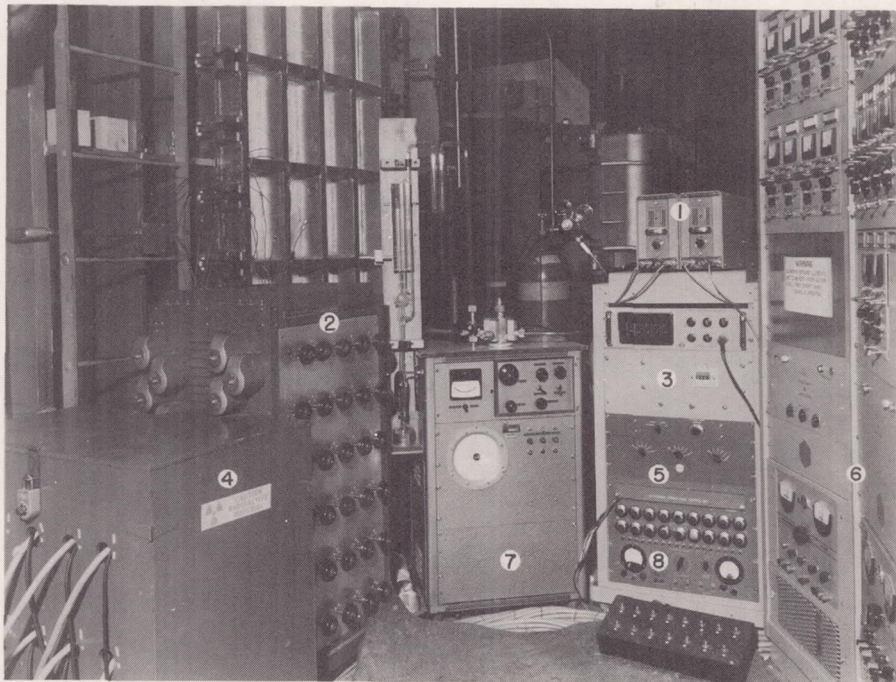

- ① DC Amplifier
- ② Control Valves
- ③ Ratio Meter
- ④ Gage Cabinet (fig.7)
- ⑤ Channel Selector
- ⑥ Alphatron Control
- ⑦ Pumping Station
- ⑧ Diaphragm Control

L-62-4749

Figure 6.- Fifteen-channel analyzer as installed in Langley Unitary Plan wind tunnel.

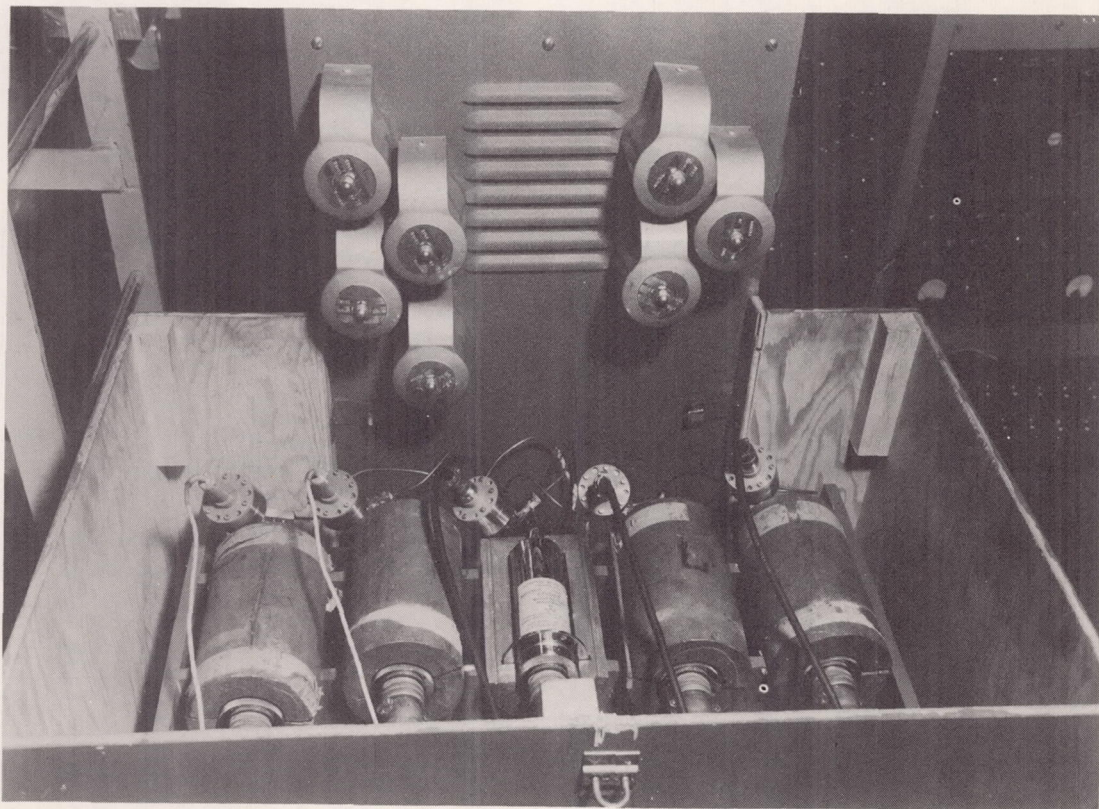

Figure 7.- Alphatron and diaphragm sensing heads. L-62-4750

The time response of the analyzer is limited mainly by the speed of the servomotor driving the ratio indicator. Evaluation in the laboratory with short connecting tubing resulted in a response from 0- to 100-percent helium in less than 30 seconds. During the tunnel runs, such factors as the operating mode, length of connecting tubing, and time required to purge excess helium from the lines and the tunnel became very significant. This resulted in an inclusive time of approximately 30 minutes per run, of which $2\frac{1}{2}$ minutes were required to scan the 15 channels and approximately 25 minutes were required for purging. The use of a ratio meter for each channel would substantially reduce the time required by limiting the amount of helium injected. To assure maximum accuracy for this application, it was decided to purge the system between each helium run. The present construction of the analyzer required fully opening all inlet and outlet valves to accomplish this, and then readjusting before the succeeding run could be made. The addition of solenoid operated bypass valves around the inlet and outlet valves will eliminate this problem for subsequent tests.

Independence of the pressure had been fully established in the laboratory, and operation during the tunnel test runs completely substantiated the phenomenon. The tunnel data obtained proved the reliability and versatility of the instrument.

CONCLUDING REMARKS

The development of the analyzer utilizing an ionization gage to measure quantitatively the compositions of helium-air mixtures has led to the following conclusions:

1. The analyzer output is independent of pressure, is linear with variations of bi-gaseous mixtures, and under laboratory conditions did not deviate more than ± 0.3 percent from the predicted values.
2. The analyzer has the capability of rapid analysis of any bi-gaseous mixture from any desired number of sampling points.
3. The system is relatively inexpensive to construct and does not require extensive training to operate.
4. With the pressure held constant, the Alphatron will exhibit a linear change in sensitivity with changes in composition of a bi-gaseous mixture.
5. A successful application of the analyzer to a specific test has shown the feasibility of this method of analysis to an ever-increasing field of investigation.

Langley Research Center,
National Aeronautics and Space Administration,
Langley Station, Hampton, Va., October 5, 1962.

REFERENCES

1. Dushman, Saul: Scientific Foundations of Vacuum Technique. John Wiley & Sons, Inc., 1958, p. 348.
2. Vitkus, P. L.: A Multi-Point Vacuum Measuring System for Low Pressure Wind Tunnels. 1959 Sixth Nat. Symposium on Vacuum Tech. Trans., C. Robert Meissner, ed., Pergamon Press (New York), 1960, pp. 89-93.
3. Anon.: Pressure Transducer - Model PT85. Bull. no. 285, Dynisco, Div. of American Brakeshoe Co., Cambridge, Mass.
4. Howe, R. M.: Design Fundamentals of Analog Computer Components. D. Van Nostrand Co., Inc., c.1961.