

*NG3-11680  
Code 1  
30 pages*

# TECHNICAL NOTE

D-1562

*copy #1*

*36p*

METHOD FOR DESIGN OF PUMP IMPELLERS USING A  
HIGH-SPEED DIGITAL COMPUTER

By Norbert O. Stockman and John L. Kramer

Lewis Research Center  
Cleveland, Ohio

NATIONAL AERONAUTICS AND SPACE ADMINISTRATION  
WASHINGTON

January 1963

NATIONAL AERONAUTICS AND SPACE ADMINISTRATION

---

TECHNICAL NOTE D-1562

---

METHOD FOR DESIGN OF PUMP IMPELLERS USING A  
HIGH-SPEED DIGITAL COMPUTER

By Norbert O. Stockman and John L. Kramer

SUMMARY

A method of designing pump impellers is derived from the equations of motion and continuity for incompressible nonviscous relative flow. The flow is assumed to follow a known stream surface (representing blade shape) that extends from hub to shroud. Equations are also derived for approximate blade-surface velocities and pressures. A detailed numerical procedure and block diagram are given for use on a digital computer. A numerical example that illustrates limited use of the method is presented and further uses are indicated.

INTRODUCTION

Centrifugal pumps are being considered for space applications in chemical and nuclear-rocket engines using cryogenic fluids and in power-conversion systems using liquid metals. For these applications, the pumps should be of minimum size and weight, should have high efficiency, and should operate cavitation-free or with controlled cavitation at high rotative speeds. A knowledge and control of the internal flow are necessary to meet these requirements.

A method based on stream-filament techniques for analyzing the flow in the impeller of a centrifugal air compressor was developed at the Lewis Research Center (ref. 1). This method determines velocities, pressures, and streamlines in the meridional plane (a plane containing the impeller axis) and of approximate velocities and pressures on the blade surfaces. From the analysis an impeller design method (ref. 2) was derived that allowed direct control of the hub velocities and indirect control of the velocities and pressures in the impeller. This method enabled the designer to avoid velocity gradients conducive to boundary-layer separation and to avoid eddy formation on the blade surfaces.

The method of reference 2 was used to redesign the shroud shapes of three existing impellers for air compressors for which experimental data were available. Data for the redesigned impellers were obtained, and the comparison of these two sets of data showed significant gains in performance of all three impellers (ref. 3).

These favorable results with air compressors, together with recent pump applications that require knowledge and control of the internal flow, led to the

use of this method for the design of centrifugal pumps. To facilitate this use, it is desirable to determine the specific flow equations and design methods for the incompressible flow in pump impellers, and to detail the procedures for high-speed digital-computer use. This report presents the development of such a method.

The basic flow equations are derived from the equations of motion for a mean-flow surface that extends from impeller hub to shroud. The required equation for stream tube volume flow is derived from continuity considerations. An approximate method of computing blade-surface flow properties is also derived.

In addition, the overall pump-design problem is discussed. Methods of obtaining quantities needed in the design calculations are given, and the numerical methods of attacking the design equations and a block diagram for a digital-computer program are presented. Finally, a numerical example illustrating the use of the method and suggestions for further use are given.

### DESIGN PROBLEM

The general design problem can be considered from two points of view, namely, the engineering and the mathematical. The engineering approach is: Given a flow rate and a head rise, find a pump that will produce the desired performance with maximum efficiency. The mathematical approach is: Given the distribution of some flow property, such as velocity, on the boundaries (hub, shroud, and blade surfaces) and assumptions regarding the type of flow, find the impeller geometry that will result in these flow properties.

Fundamentally, the problem is an engineering one; that is, the pump must produce a certain flow and a certain head rise and possibly meet other restrictions, such as a maximum allowable diameter, a specified rotative speed, and so forth. Commonly, the engineering goal is achieved through the combined use of a certain amount of mathematical design, the designer's art and experience, and possibly development.

The ideal approach would be to convert the engineering specifications into inputs for a complete mathematical design, to specify desirable flow properties along the impeller boundaries, and to compute the geometry of the impeller.

Unfortunately, complete three-dimensional design methods, such as suggested in reference 4, are long and complex. Even when a high-speed digital computer is available for the computation, the setting up of the problem for the computer would be a long and tedious process. An exact two-dimensional method is used in references 5 and 6 to obtain blade-to-blade properties in a prescribed pump stream-tube impeller geometry without and with splitter vanes, respectively. This method gives an adequate picture of the flow in the leading-edge region and would be useful for cavitation considerations; however, the exact solution is quite complex and involves considerable calculations. It is important, therefore, that rapid easy-to-use methods accurate enough for engineering purposes be developed. Two such methods of obtaining flow properties on the blade surfaces are given in references 1 and 7. In references 5 and 6, it was found that these

methods gave reasonably accurate results throughout most of the blade passage. Although these methods are of limited value for studying cavitation conditions, they are sufficient for eddy detection and for boundary-layer and loading studies except in the immediate vicinity of the trailing edge and in a region near the leading edge that extends further into the impeller as the angle of attack deviates from the design value.

The hub-shroud design method presented herein (with optional blade-surface computations) is another such rapid and easy-to-use method. It enables the designer to proceed from a known streamline and its velocity distribution to an adjacent streamline and its velocity distribution. Thus, given the conditions along the hub, the entire hub-shroud profile is built up by proceeding from the hub streamline to the next streamline, and so on, until the shroud is reached. Conversion of the pump specifications into input for the design calculations is described in the DESIGN INPUTS section.

## DESIGN EQUATIONS

### Stream Tube Volume Flow

The coordinates of an unknown streamline are related to those of an adjacent known streamline by a form of the continuity equation. In the derivation of this equation, it is assumed that surfaces of revolution obtained by rotating streamlines about the impeller axis are stream surfaces and that all passages between blades carry the same volume flow. Then the equation for the volume flow per unit blade passage  $\Delta Q/M$  through a cross section of a stream tube bounded by adjacent surfaces of revolution  $n_1$  and  $n_2$  and by adjacent blades  $\theta_t$  and  $\theta_d$ , as shown in figure 1, is obtained by

$$\frac{\Delta Q}{M} = \int_A W_m \, dA = \int_{n_1}^{n_2} \int_{\theta_t(n)}^{\theta_d(n)} W_m r \, d\theta \, dn \quad (1)$$

where  $A$  is the area of a cross section of stream tube everywhere normal to the meridional or through-flow direction,  $W_m$  is the meridional or through-flow velocity component and is a function of  $n$  and  $\theta$ , and  $r$  is the radial distance to the center of the element and is a function of  $n$ . (All symbols are defined in appendix A.)

### Velocity Gradient

The velocity-gradient equation (which is derived in appendix B) is used to obtain the velocity on a new streamline when it is known on an adjacent streamline. Simplification of the exact three-dimensional equations of motion to a simple velocity-gradient equation is accomplished in two major steps. In the first step, the problem is reduced to two dimensions by considering the flow on a known stream surface  $S$  (fig. 2) that extends from hub to shroud throughout

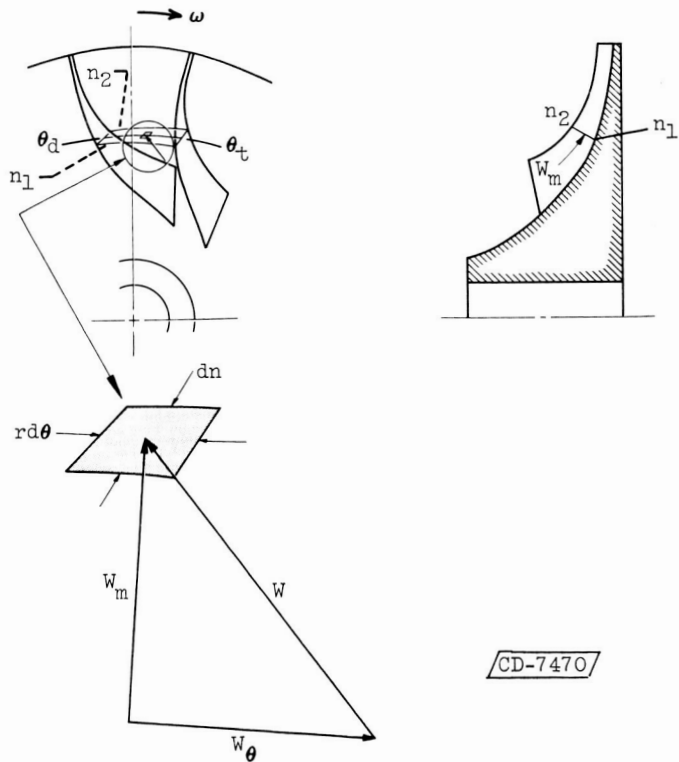

Figure 1. - Cross section of stream tube.

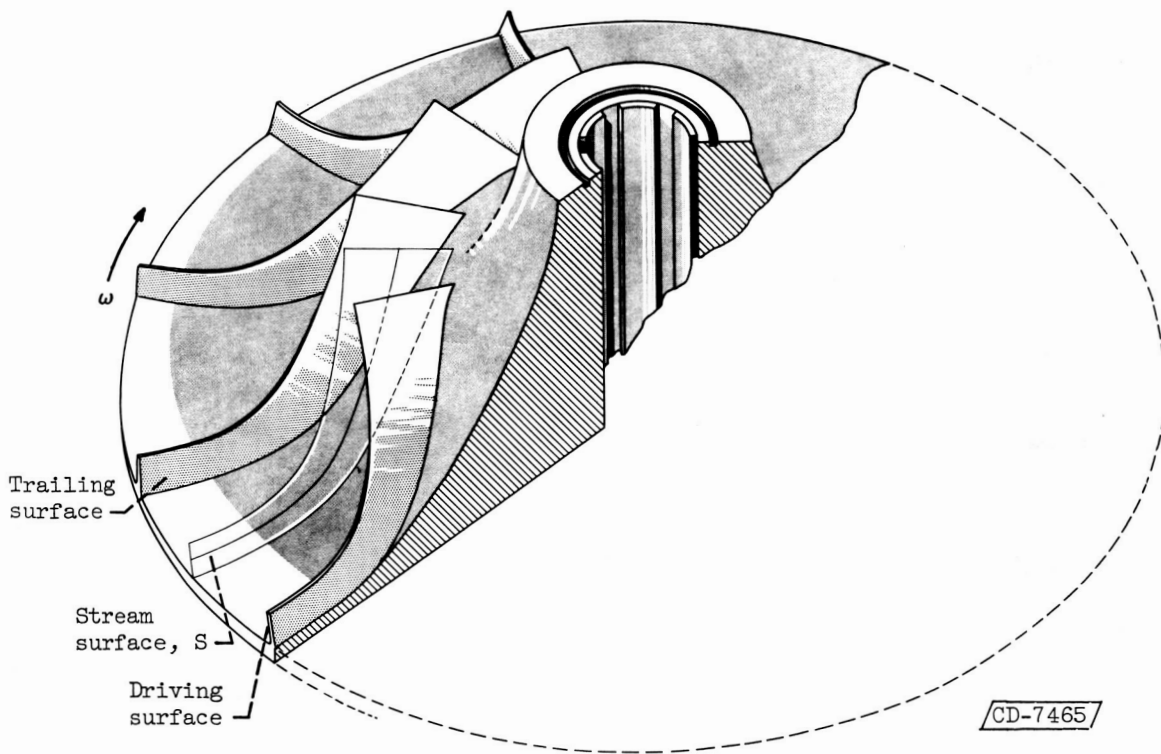

Figure 2. - Pump impeller showing stream surface between blades.

the impeller. Mathematically, this surface can be any stream surface between blades. It is reasonable to assume that the mean flow follows a mean blade surface throughout the guided portion of the impeller. At the inlet, the surface deviates from the mean blade surface for nonzero angle of attack and, at the outlet, it differs because of slip. These two factors can be taken into account and are discussed in the section on Blade Properties.

In general, flow properties are functions of  $\theta$ ,  $r$ , and  $z$ ; but on the surface,  $\theta$  is a function of  $r$  and  $z$ . Therefore, the flow on the surface is a function of  $r$  and  $z$  only; that is, it is mathematically two dimensional. As a result, the design calculations can be set up as if the flow were in an  $r$ - $z$  or meridional plane. A meridional plane is a plane that contains the impeller axis, but it is not a physically meaningful plane in the flow field (except in the case where there is no relative circumferential velocity). An advantage of working in the meridional plane is that the meridional streamline picture is a true representation of the through flow associated with the surface  $S$ .

In the second step, the two-dimensional equations are further simplified by considering flow conditions along meridional streamlines and gradients along normals to these streamlines (fig. 3). This consideration results in the velocity-gradient equation

$$\frac{dW}{dn} = aW - b \quad (2)$$

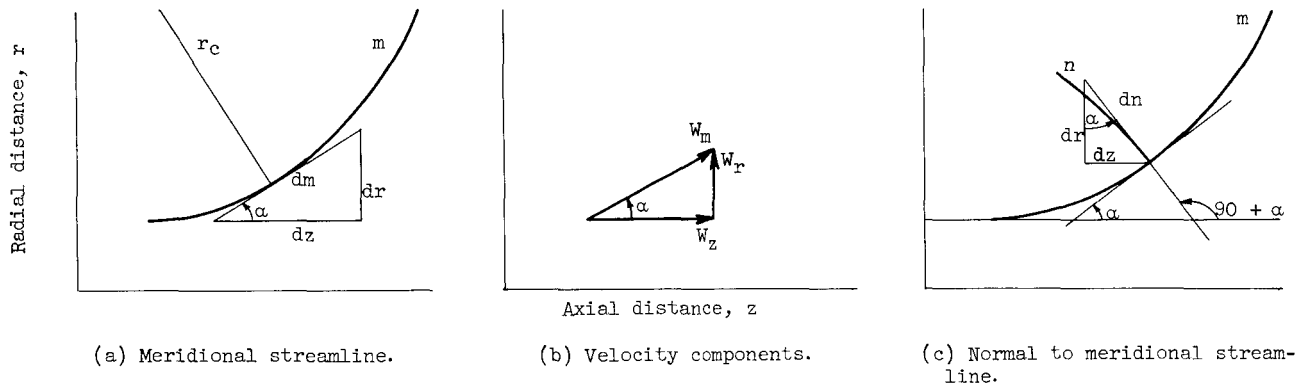

Figure 3. - Meridional plane.

where

$$a = \frac{\cos^2 \beta}{r_c} - \frac{\sin^2 \beta \cos \alpha}{r} - \frac{B \cos \beta \sin \beta \sin \alpha}{r} \quad (3)$$

and

$$b = 2\omega \sin \beta \cos \alpha + B \cos \beta \left( \frac{dW_\theta}{dm} + 2\omega \sin \alpha \right) - \frac{g}{W} \frac{dH_1}{dn} + \frac{\omega}{W} \frac{d\lambda}{dn} \quad (4)$$

In equation (2),  $W$  is the fluid velocity relative to the rotating impeller and  $n$  is distance along a normal to the meridional streamline. All quantities in  $a$  and  $b$  are given as design inputs (e.g.,  $\omega$ ) or are computed from the geometry (e.g.,  $\alpha$ ) or from flow properties (e.g.,  $dW_\theta/dn$ ) of a known (i.e., initially prescribed or previously calculated) meridional streamline. These quantities are discussed as they appear in the derivation in appendix B. Briefly, from the meridional streamline geometry shown in figure 3(a),

$$\tan \alpha = \frac{dr}{dz}$$

$$dm = \sqrt{dr^2 + dz^2}$$

$$\frac{1}{r_c} = \frac{d\alpha}{dm}$$

and from blade-shape specification,  $\partial\theta/\partial r$  and  $\partial\theta/\partial z$ ,

$$B = r \frac{\partial\theta}{\partial z} \sin \alpha - r \frac{\partial\theta}{\partial r} \cos \alpha$$

$$\tan \beta = r \frac{\partial\theta}{\partial r} \sin \alpha + r \frac{\partial\theta}{\partial z} \cos \alpha$$

Physically,  $\beta$  is the angle measured from the meridional projection to the streamline of the flow surface (fig. 4). The angle is positive when measured in

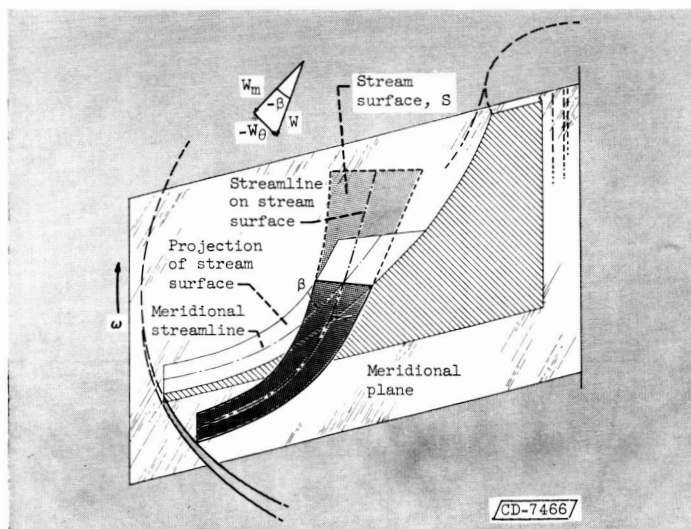

Figure 4. - Projection of stream surface onto meridional plane.

the direction of rotation. The remaining quantities in b are obtained as follows:  $W_\theta$  equals  $W \sin \beta$ ;  $\omega$ , the rotative speed of the impeller, is prescribed;  $\frac{dH_i}{dn} = \frac{\Delta H_i}{\Delta n}$  where  $\Delta H_i$  is obtained from a prescribed distribution of  $H_i$  at the inlet and  $\Delta n$  is obtained from continuity; and  $\frac{d\lambda}{dn} = \frac{\Delta \lambda}{\Delta n}$  as for  $\frac{dH_i}{dn}$ .

With the two equations, velocity (eq. (2)) and continuity (eq. (1)), the hub-shroud profile can be constructed from a given meridional streamline and its velocity distribution and a given blade shape. The velocity on the stream surface throughout the impeller is of necessity obtained as part of the design calculation.

### Head

The static head  $h$  along a streamline can be obtained from equation (B22):

$$h = H_i - \frac{W^2}{2g} + \frac{\omega^2 r^2}{2g} - \frac{\omega \lambda}{g}$$

where  $H_i$  is the inlet total head that is given for each streamline.

The total head along a streamline can be computed from equation (B28):

$$H = H_i + \frac{\omega r V_\theta}{g} - \frac{\omega \lambda}{g} = H_i + \frac{\omega r W_\theta}{g} + \frac{\omega^2 r^2}{g} - \frac{\omega \lambda}{g}$$

This completes the incompressible nonviscous flow calculations on the stream surface  $S$ .

### Blade-to-Blade Calculations

Approximate blade-surface velocities and static heads can be obtained from equations (C3) to (C7). These equations are derived in appendix C with the assumption of a linear variation of static head from blade to blade. They provide results of satisfactory accuracy except in the leading- and trailing-edge regions of the blades. If more exact results are required, the blade-to-blade analysis method of references 5 or 6 can be used.

### DESIGN INPUTS

The equations presented in the previous section enable computation of the internal-flow conditions and the shroud shape of a pump impeller provided that the following quantities are known, that is, given or prescribed: volume flow



rate,  $Q$ ; head rise,  $\Delta H$ ; inlet-total-head distribution,  $H_i$ ; inlet-prewhirl distribution,  $\lambda$ ; rotative speed,  $\omega$ ; meridional contour of some streamline such as the hub,  $r = r(z)$ ; velocity along this streamline,  $W = W(r, z)$ ; the mean blade surface in terms of the curvature components,  $\partial\theta/\partial r$  and  $\partial\theta/\partial z$ ; the blade thickness,  $t_n$  or  $t_\theta$ ; the number of blades,  $M$ ; and any deviation of the flow surface from the blade surface such as slip or angle of attack.

The flow rate  $Q$  and the head rise  $\Delta H$  will usually be given as pump specifications. The rotative speed  $\omega$  is sometimes given. In general,  $\omega$ ,  $Q$ ,  $\Delta H$ ,  $H_1$ , and  $\lambda$  are not directly related to hub shape, velocity along the hub, blade shape, and number of blades, so the designer has considerable freedom in prescribing these quantities. At the inlet and at the outlet of the pump, however, certain relations among these quantities and  $Q$  and  $\Delta H$  must be satisfied.

#### Outlet Conditions

At the outlet, two equations must be satisfied. The first is Euler's turbine equation:

$$\Delta H = \frac{\eta\omega}{g} (rW \sin \beta + \omega r^2 - \lambda)_{av} \quad (5)$$

In equation (5),  $\eta$  is the hydraulic efficiency defined by

$$\eta = \frac{\Delta H_{\text{actual}}}{\Delta H_{\text{ideal}}}$$

The hydraulic efficiency may be estimated from a consideration of losses or it may be assigned from experience. The rotative speed  $\omega$  may be chosen to be consistent with other free choices in equation (5) or it may be predetermined by other considerations; for example, the  $\omega$  of a direct-drive turbine that will drive the pump.

If slip is to be taken into account, equation (5) becomes

$$\Delta H = \frac{\eta\omega}{g} \left[ r f_s (W \sin \beta + \omega r) - \lambda \right]_{av}$$

where  $f_s$  is the slip factor and is defined and discussed in the section on Blade Properties.

The second equation is the equation for volume flow rate:

$$Q = (W \cos \beta)_{av} \left( 2\pi r - M t_\theta \right)_{av} \left( \frac{r_s - r_h}{\cos \alpha_{av}} \right) \quad (6a)$$

or for a radial outlet when  $\alpha = 90^\circ$  and  $r_s = r_h$

$$Q = (W \cos \beta)_{av} (2\pi r - Mt_\theta)_{av} (z_s - z_h) \quad (6b)$$

The values of any quantities ( $W$ ,  $\beta$ , etc.) needed in the design must be prescribed at the outlet to be consistent with equations (5) and (6) and with any other constraints imposed, for example, the existing geometry of the system in which the pump will be used. In equations (5) and (6) the subscript  $av$  refers to average values between hub and shroud. In practice, however, these equations are used to obtain input values on the prescribed streamline. The result of this procedure is that the pump may produce a somewhat different head rise or flow rate from that specified. If this is a significant deviation, the prescribed streamline and its related input can be adjusted after a trial design. This adjustment can be repeated as often as required.

### Inlet Conditions

There are four possible situations that may confront the designer at the pump inlet: (1) The upstream flow conditions are given, for example, when an inducer precedes the pump; (2) the upstream geometry is given, for example, a predetermined inlet pipe; (3) the geometry immediately upstream of the pump is the responsibility of the pump designer; and (4) there are no restrictions on the inlet conditions, for example, it is the responsibility of someone else to make the inlet section fit the pump.

For item (2), the upstream section can be analyzed (from essentially the same equations as those used for the pump design) and the flow conditions are then known. This situation is now the same as item (1). For item (3), the inlet section can be designed by the method of this report (with certain changes because there are no blades) then the flow is known as in the situation in item (1). Thus, for inlet conditions required as design input, there are two different situations, namely, items (1) and (4). In both cases, the relations of continuity

$$\Delta Q = (2\pi r - Mt_\theta) \Delta n W \cos \beta \quad (7)$$

where

$$\Delta n = \frac{r_2 - r_1}{\cos \alpha_1}$$

except in the case of a radial inlet  $\alpha = 90^\circ$  where

$$\Delta n = z_2 - z_1$$

and conservation of angular momentum

$$W \sin \beta = \frac{\lambda}{r} - \omega r \quad (8)$$

must be satisfied at each streamline for item (1) and at some mean streamline for item (4).

Note that equation (7) is written for a station just inside the impeller inlet rather than just upstream of the inlet and, therefore, includes blade blockage. Also, note that in equation (8) it is assumed that no work has yet been done on the fluid at this station. Not all quantities involved in equations (7) and (8) are actual design input at every streamline. Only the prescribed streamline (usually the hub) has a  $W$  and  $r$  as input. Values of  $\lambda$  and  $H_1$  (which does not appear in the equations) are required input at every streamline even when upstream conditions are not prescribed. Values of  $\beta$ ,  $t_\theta$ , and  $M$  across the inlet are incorporated into the blade input. Angle  $\beta$  is the angle of the flow surface not the blade surface, so that when these angles are not equal (when the angle of attack is not zero) the blade shape at the inlet must be specified in such a way as to produce the required value of  $\beta$ .

When equations (7) and (8) are used to relate average conditions, as in item (4),  $\Delta Q$  becomes  $Q$ ,  $\Delta n$  becomes  $(r_s - r_h)/\cos \alpha_{av}$  or  $z_s - z_h$ , and other quantities are averages from hub to shroud. Values for the prescribed streamline are estimated from the hub-to-shroud average values. After a design is made, the inlet should be reexamined at each streamline to be sure that conditions are satisfactory. In particular, the blade angle at each streamline should be such as to produce the expected angle of attack (usually zero). If the expected angle of attack is not attained, some inlet condition or the blade shape at the inlet must be changed.

In cases where the upstream flow is known before the pump is designed, the streamlines resulting from the design calculation must match the upstream streamlines at the inlet. If these two sets of streamlines do not match, some input condition must be changed, and a new design calculation carried out. This process is repeated until a satisfactory match is achieved.

### Hub Shape and Velocity Distribution

After the inlet and outlet conditions are determined, the meridional contour and velocity distribution of some streamline must be chosen throughout the pump. This could be the hub, the shroud, or any other streamline in between. It is probably best to start with the hub, since streamline spacing is most sensitive to velocity changes near the hub and undesirable resulting shapes in succeeding streamlines can be more readily eliminated. Usually the hub radius  $r$  and velocity  $W$  are given as functions of  $z$ . Both  $r$  and  $W$  may be prescribed directly, or, for better control of cavitation, the static head  $h$  may be prescribed together with either  $W$  or  $r$ . These three quantities are related in equation (B22).

If static head and velocity are prescribed, the hub shape is obtained from

$$r = \frac{1}{\omega} \sqrt{2g(h - H_1) + W^2 + 2\omega\lambda}$$

If static head and hub shape are chosen, the velocity is found from

$$W = \sqrt{2g(H_1 - h) + \omega^2 r^2 - 2\omega\lambda}$$

The velocity distribution on the hub, according to air-compressor experience, should be accelerating, if possible. At least unnecessary negative velocity gradients should be avoided. The static-head distribution should be such that cavitation is avoided or controlled. No useful criterion is known for hub shape except perhaps ease of fabrication.

If it is more desirable to have direct control over conditions on the shroud, this can be done, and the design method can be made to proceed from the shroud to the hub by changing the sign of  $\Delta n$  in the equations.

#### Blade Properties

When the mean flow surface is assumed to follow the mean blade surface, the blade shape is usually prescribed in two parts: a mean blade surface and a thickness distribution. In general, the mean blade surface is of the form  $\theta = \theta(r, z)$ . For very high speed wheels, it is often limited to radial elements and is of the form  $\theta = \theta(z)$ . The blade surface should be prescribed in such a manner that the angle  $\beta$  can be computed conveniently at any point. One method would be to prescribe  $\partial\theta/\partial r$  and  $\partial\theta/\partial z$ , the blade-curvature components in the  $r$ - and  $z$ -directions, respectively. The angle  $\beta$  is found from the relation

$$\tan \beta = r \frac{\partial\theta}{\partial r} \sin \alpha + r \frac{\partial\theta}{\partial z} \cos \alpha \quad (9)$$

Equation (9) results from the relation

$$\tan \beta = r \frac{d\theta}{dm} = r \frac{\partial\theta}{\partial r} \frac{dr}{dm} + r \frac{\partial\theta}{\partial z} \frac{dz}{dm}$$

which holds along a streamline where  $\theta$ ,  $r$ , and  $z$  are functions of  $m$ .

For the case of radial blade elements ( $\partial\theta/\partial r = 0$ ) or axial elements ( $\partial\theta/\partial z = 0$ ), the following method may be used to determine the mean blade surface. Instead of prescribing the blade angle, either the total head rise  $H - H_1$  or the relative tangential velocity along the hub is prescribed. Then  $\beta$  along the hub is found from

$$\beta = \sin^{-1} \frac{W_\theta}{W}$$

where

$$W_{\theta} = \frac{g(H - H_i)}{\omega r} + \frac{\lambda}{r} - \omega r$$

For radial blade elements

$$\frac{\partial \theta}{\partial z} = \frac{1}{r_h} \frac{\tan \beta}{\cos \alpha}$$

where  $\beta$  and  $\alpha$  are known as functions of  $z$  along the hub; therefore, since  $\partial \theta / \partial z$  is independent of  $r$ ,  $\partial \theta / \partial z$  is known everywhere as a function of  $z$ .

For axial blade elements

$$\frac{\partial \theta}{\partial r} = \frac{1}{r_h} \frac{\tan \beta}{\sin \alpha}$$

and  $\partial \theta / \partial r$  is known everywhere as a function of  $r$ , since  $\beta$  and  $\alpha$  are known along the hub as functions of  $r$ .

Although  $\theta$  is not needed in the design procedure, it is usually needed for fabrication and can be obtained from

$$d\theta = \frac{\partial \theta}{\partial r} dr + \frac{\partial \theta}{\partial z} dz$$

Since the flow near the outlet of the pump does not closely follow the blades, a closer approximation to actual flow can be obtained if a reasonable value of the slip factor can be estimated. The slip factor  $f_s$  is defined as the ratio of the absolute tangential velocity of the fluid at the outlet to the absolute tangential velocity the fluid would have if the flow angle were equal to the mean blade angle, that is, if the fluid were perfectly guided by the blades. The effect of slip is taken into account in computing the flow angle  $\beta$ . At the outlet,  $\beta$  is computed from the slip factor, the mean blade angle, and the flow rate. In reference 7, a parabolic variation in  $\sin \beta$  is assumed to hold from a point in the pump where the effect of slip begins (and where  $\beta$  is known from eq. (9)) to the outlet. Angle  $\beta$  is then computed in this region from the parabolic variation instead of equation (9). The point where slip is assumed to become significant can be estimated from experience or can be computed from an empirical formula such as that given in reference 7.

A similar situation exists at the inlet where the actual mean stream surface may differ significantly from the mean blade surface in the case of nonzero angle of attack. The angle of attack, or incidence angle, at some streamline is defined as the angle between the mean flow direction at the inlet and the mean blade surface at the blade leading edge. Then the  $\beta$  of equations (7) and (8) is not the  $\beta$  of the mean blade surface. The mean blade surface at the inlet then has to be specified in such a way that its angle is equal to angle  $\beta$  plus the angle of attack. The effect of angle of attack extends somewhat into the

impeller and could be accounted for in a manner similar to that discussed previously for slip factor. Note that even though the mean blade angle at some mean streamline satisfies equations (7) and (8) at the inlet, there may still be nonzero angle of attack at other streamlines and, if significant, should be taken care of as done previously. Reference 2 discusses computation of angle of attack.

The blade thickness may be prescribed in any manner that allows its computation as a function of  $z$  and  $r$ . Normally,  $t_n$  is prescribed, but the thickness in the circumferential direction  $t_\theta$  is required for the design method and is given by

$$t_\theta = t_n \sqrt{1 + r^2 \left( \frac{\partial \theta}{\partial z} \right)^2 + r^2 \left( \frac{\partial \theta}{\partial r} \right)^2} \quad (10)$$

The initial choice of the number of blades is best determined by experience. The number need not be constant, that is, splitter vanes or partial blades may be added at various stations throughout the pump impeller. Since the flow is assumed to be periodic, the number of blades (including splitter vanes) at any station should be an integral multiple of the number at the previous station.

The hub shape, velocity along the hub, blade shape, and number of blades may be changed if the initial values result in undesirable flow conditions (see NUMERICAL EXAMPLE AND DISCUSSION).

#### NUMERICAL PROCEDURE

The numerical solution of equations (1) and (2) is based on the fundamental assumption that the distance  $\Delta n$  between adjacent streamlines is small enough so that properties can be assumed to be constant across  $\Delta n$ .

In equation (2), assume that  $a$  and  $b$  are constant across a stream tube from  $n_1$  to  $n_2$ . If equation (2) is multiplied by the integrating factor  $e^{\int -a \, dn}$ , it can be integrated to give

$$W_2 = W_1 e^{a \Delta n} + \frac{b}{a} (1 - e^{a \Delta n}) \quad (11)$$

where  $\Delta n = n_2 - n_1$ .

Equation (11) is used to compute  $W_2$  when  $W_1$  is known. The parameters  $a$  and  $b$  are computed along the streamline at  $n_1$ , and  $\Delta n$  is computed from the next equation to be developed.

Equation (1) can be solved by applying the mean-value theorem. First, consider the integration with respect to  $\theta$ :

$$\int_{\theta_d(n)}^{\theta_t(n)} W_m r \, d\theta = \bar{W}_m r [\theta_t(n) - \theta_d(n)]$$

where  $\bar{W}_m$  is evaluated at some  $\bar{\theta}$ . Assume that  $\bar{W}_m$  is the  $W_m$  of the mean surface  $S$ . At any value of  $n$

$$r [\theta_t(n) - \theta_d(n)] = \frac{2\pi r - Mt_\theta}{M}$$

where  $r$  and  $t_\theta$  are functions of  $n$ . Now equation (1) can be written as

$$\Delta Q = \int_{n_1}^{n_2} W_m (2\pi r - Mt_\theta) dn \quad (12)$$

Assume that  $W_m (2\pi r - Mt_\theta)$  is constant across  $\Delta n$ . Then

$$\Delta Q = W_m (2\pi r - Mt_\theta) (n_2 - n_1)$$

Hence

$$\Delta n = \frac{\Delta Q}{W_m (2\pi r - Mt_\theta)} \quad (13)$$

where  $W_m (2\pi r - Mt_\theta)$  is evaluated on the streamline at  $n_1$ , as are the parameters  $a$  and  $b$  of equation (11).

Coordinates of a new streamline are obtained by assuming that  $\alpha$  is constant across a stream tube and by integrating equations (B13) and (B12), respectively, to give

$$r_2 = r_1 + \Delta n \cos \alpha \quad (14)$$

and

$$z_2 = z_1 - \Delta n \sin \alpha \quad (15)$$

The two normal derivatives that occur in  $b$  are computed from streamline-input data for a linear variation with  $n$  assumed at each station:

$$\left(\frac{dH_i}{dn}\right)_1 = \frac{(H_i)_2 - (H_i)_1}{\Delta n} \quad (16)$$

$$\left(\frac{d\lambda}{dn}\right)_1 = \frac{\lambda_2 - \lambda_1}{\Delta n} \quad (17)$$

The numerical method employed to compute derivatives at discrete points along a streamline is a "spline curve fit" technique taken from the SHARE Program for IBM 704 users. Briefly, the method requires a set of points and the slopes at the end points for which a cubic polynomial is defined for each interval (between adjacent points) such that the function represented by the set of cubic equations has continuous first derivatives within the given range. Since the end-point derivatives are usually not known, they too must be computed numerically by a method such as Newton's end-point formulas (ref. 8).

A block diagram for a digital-computer program is shown in figure 5. The diagram is explained by block number as follows:

(1) Read pump input data:

- (a) Number of stations (points along the streamline),  $J$
- (b) Number of streamlines,  $K$
- (c) Rotative speed,  $\omega$
- (d) Flow rate,  $Q$
- (e) Number of blades at each station,  $M$
- (f) Prerotation for each streamline,  $\lambda$
- (g) Inlet total head for each streamline,  $H_i$
- (h) Coordinates of hub for each station,  $z, r$
- (i) Relative velocity at each station on hub,  $W$
- (j) Tabular blade-shape data as functions of  $r$  and  $z, \partial\theta/\partial z, \partial\theta/\partial r$
- (k) Tabular blade thickness as function of  $r$  and  $z, t_n$



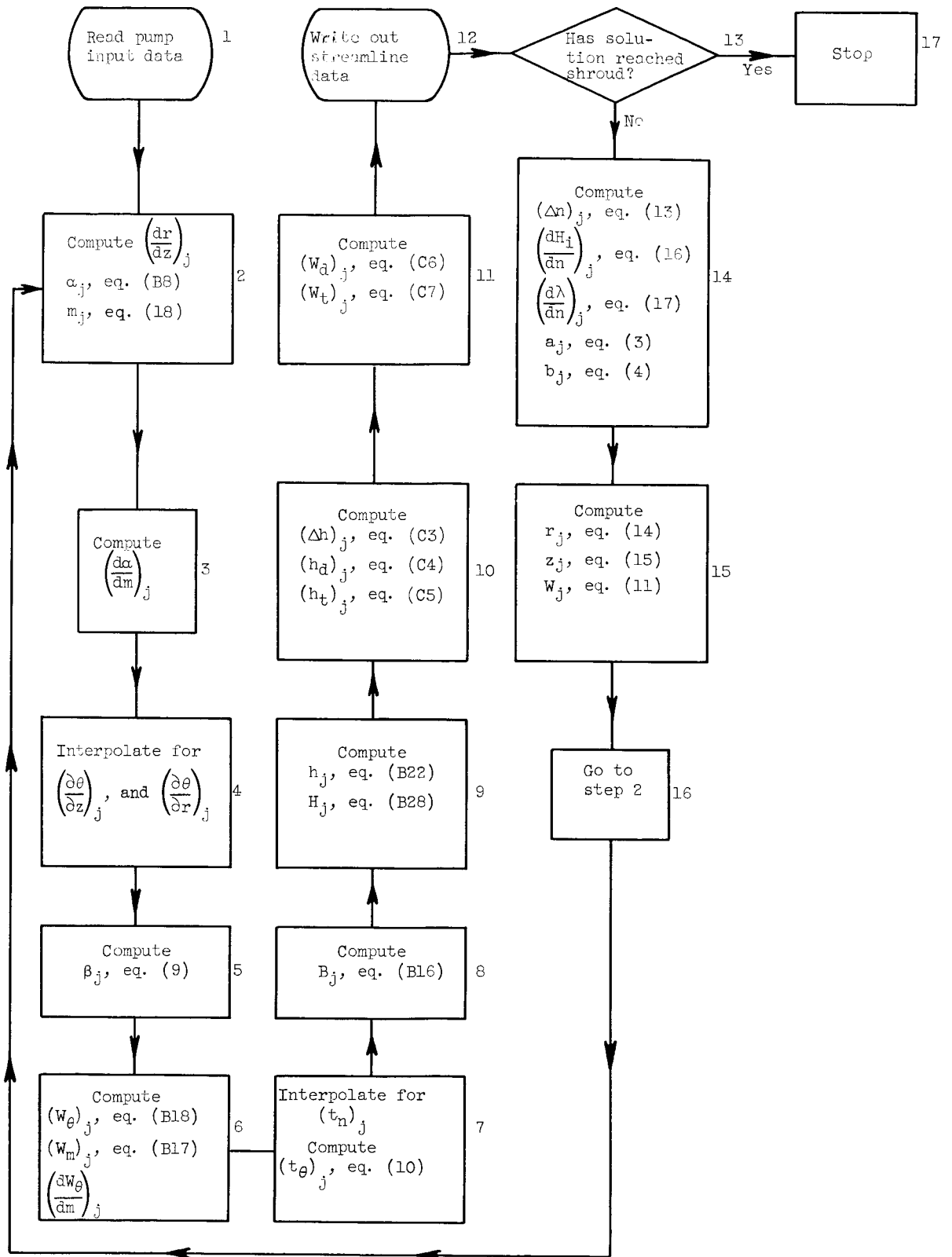

Figure 5. - Block diagram for computer program.

For the remaining steps, the subscript  $j$  refers to stations along a streamline and is in the range  $j = 1, 2, \dots, J$ .

- (2) Compute  $(dr/dz)_j$  from spline curve fit,  $\alpha_j$  from equation (B8), and  $m_j$  from

$$m_j = m_{j-1} + \left[ 1.0 + \left( \frac{dr}{dz} \right)_j^2 \right]^{1/2} dz \quad \text{for } 2 \leq j \leq J \quad (18)$$

where  $m_1 = 0$

- (3) Compute  $(d\alpha/dm)_j$  from curve fit
- (4) Obtain blade-shape data,  $(\partial\theta/\partial z)_j$  and  $(\partial\theta/\partial r)_j$ , by interpolation from the tables (step (1)(j))
- (5) Compute  $\beta_j$  from equation (9)
- (6) Compute  $(W_\theta)_j$  from equation (B18),  $(W_m)_j$  from equation (B17), and  $(dW_\theta/dm)_j$  from curve fit
- (7) Obtain blade-thickness data  $(t_n)_j$  by interpolation from the tables (step (1)(k)) and compute circumferential thickness  $(t_\theta)_j$  from equation (10)
- (8) Compute  $B_j$  from equation (B16)
- (9) Compute static head  $h_j$  from equation (B22) and total head  $H_j$  from equation (B28)

Steps (10) and (11) are the blade-surface calculations and are optional, since they are not essential steps in the design procedure.

- (10) Compute  $(\Delta h)_j$  from equation (C3),  $(h_d)_j$  from equation (C4), and  $(h_t)_j$  from equation (C5)
- (11) Compute  $(W_d)_j$  from equation (C6) and  $(W_t)_j$  from equation (C7)
- (12) Write out desired streamline data. In working from the hub to the shroud, the first streamline data will be that associated with the hub.

Quantities that occur in the calculation procedure of potential interest are:

- (a) Streamline coordinates
  - (b) Resultant and component velocities
  - (c) Meridional streamline curvature
  - (d) Blade-curvature components
  - (e) Angles  $\alpha$  and  $\beta$
  - (f) Static head and total head
  - (g) Blade-surface velocities and static head
  - (h) Circumferential blade thickness
- (13) Test whether or not the solution has reached the shroud. (If the shroud is the starting streamline, the logic is still the same and the design is finished when the hub is reached; however, if some intermediate streamline is the initial one, the design has to proceed from this streamline to both the hub and the shroud, and the logic must be changed slightly.) If the solution has reached the shroud, go to step (17); if it has not, go to step (14).
- (14) Compute  $(\Delta n)_j$  from equation (13),  $\left(\frac{dH_1}{dn}\right)_j$  from equation (16),  $\left(\frac{d\lambda}{dn}\right)_j$  from equation (17),  $a_j$  from equation (3), and  $b_j$  from equation (4)
- (15) Compute next streamline coordinates and velocity:  $r_j$  from equation (14),  $z_j$  from equation (15), and  $W_j$  from equation (11)
- (16) Return to step (2)
- (17) Stop

#### NUMERICAL EXAMPLE AND DISCUSSION

The digital-computer program as outlined in the preceding section was applied to a numerical example for the purpose of illustrating the use of the method. The following is a list of the conditions prescribed:

- (1) Number of stations, 26, approximately equally spaced with distance along meridional hub contour

- (2) Number of streamlines, 40
- (3) Rotative speed,  $\omega$ , 1571 radians/sec
- (4) Flow rate,  $Q$ , 48 cu ft/sec
- (5) Number of blades,  $M$ , 4 at each station (no splitter vanes)
- (6) Prewhirl,  $\lambda$ , 0; inlet total head,  $H_1$ , 1304 ft
- (7) Hub contour,  $r = r(z)$ , as in figure 6(a)
- (8) Hub velocity distribution,  $W$ , shown in figure 6(b) as function of  $m/m_J$

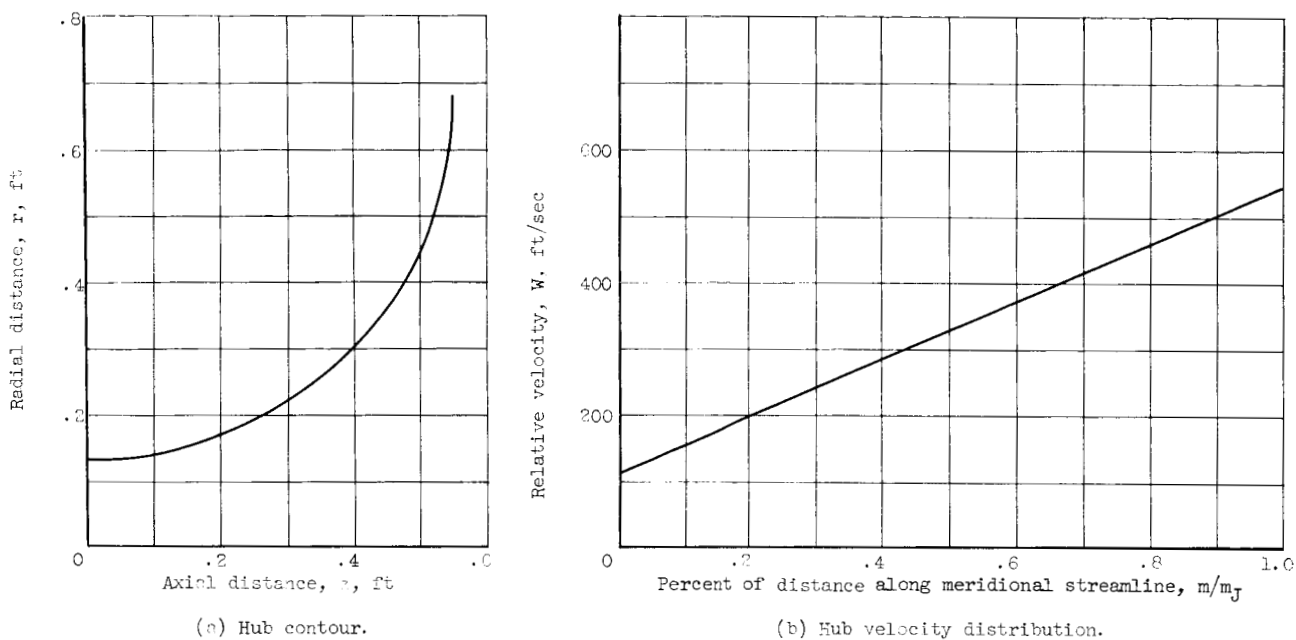

Figure 6. - Hub input data for numerical example.

- (9) Blade-shape data,  $\partial\theta/\partial z$  or  $\partial\theta/\partial r$ , as functions of  $z$ . The quantity  $\partial\theta/\partial z$  is a linear function of  $z$  from 0.000 to 0.400 as shown in the following table:

Axial distance from impeller inlet, $z$	Blade-shape specification	
	$\frac{\partial\theta}{\partial z}$	$\frac{\partial\theta}{\partial r}$
0.000	-10.39374	0.0
.050	-9.09453	↓
.150	-6.49609	
.250	-3.89765	
.350	-1.29922	
.390	-.25984	
.395	-.12992	
.400	0	
.405	↓	
.410	↓	
.500	↓	
.600	↓	

(10) Constant blade thickness,  $t_n$ , 0.0075 ft

Figure 7(a) shows some of the computed streamlines from the hub to the shroud. Figure 7(b) shows the velocity distributions along each of these

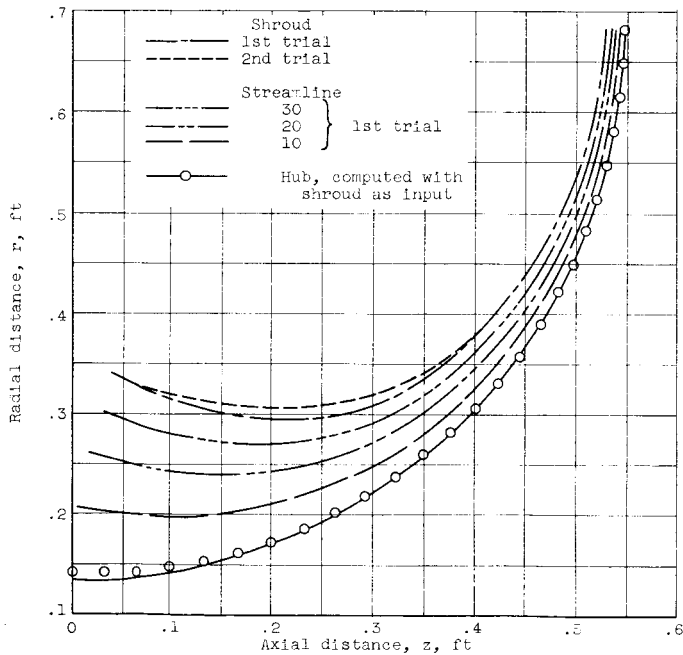

(a) Computed streamlines from hub to shroud.

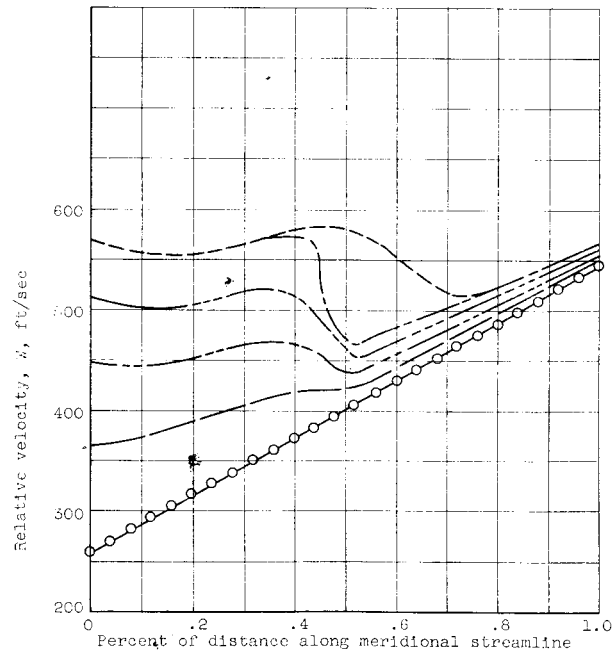

(b) Velocity distributions along computed streamlines from hub to shroud.

Figure 7. - Meridional streamlines and velocity distributions for numerical example.

streamlines. Figure 7 represents the first trial to obtain acceptable shroud shape and shroud velocity distribution with the conditions prescribed previously.

In order to improve the shroud velocity distribution, it was decided to distribute the blade curvature over a greater axial distance, in particular, to vary  $\partial\theta/\partial z$  linearly with  $z$  to a value of  $z$  of 0.500 instead of 0.400. The new blade data is shown in the following table:

Axial distance from impeller inlet, $z$	Blade-shape specification	
	$\frac{\partial\theta}{\partial z}$	$\frac{\partial\theta}{\partial r}$
0.000	-10.39374	0.0
.050	-9.35437	↓
.150	-7.27562	
.250	-5.19687	
.350	-3.11812	
.450	-1.03937	
.490	-.20786	
.495	-.10394	
.500	0	
.505		
.510		
.550		
.600		

The second trial shroud shape and shroud velocity distribution are shown by dashed lines in figures 7(a) and (b), respectively. The number of blades, hub contour, and hub velocity may also be changed to improve the solution. This process can then be repeated until an acceptable shroud and shroud velocity distribution are obtained.

Although it was not done for the numerical example the blade-surface velocities, in an actual design, also would be computed for each meridional streamline, which would enable the designer to exercise a certain amount of indirect control over these velocities. It is usually not practical to eliminate all undesirable qualities of the velocities. For example, all blade-surface deceleration could not be eliminated. The chief utility of the blade-surface computations is that they can indicate severe undesirable gradients and the presence of an eddy on the driving surface. It is usually fairly easy to eliminate the eddy in later trials by raising the hub velocity, changing the blade shape, or, more commonly, by adding splitter vanes between blades at the station where the negative velocity first appears. For numerical examples of blade-surface velocities computed by two approximate methods (including the one presented in this report) and their comparison with exact solutions see references 5 and 6. Reference 6 gives results for a pump with splitter vanes.

Although the approximate blade-surface computations also permit indirect control over the blade-surface static head or pressure, they are unfortunately of quite limited value in studying cavitation conditions, as is pointed out in reference 5. If the time and effort were warranted, however, the method of reference 5, applied to only one stream tube, might give sufficient information for cavitation studies. (In ref. 5, angle of attack was not taken into account in the approximate calculations so that the off-design case shows worse agreement with the exact solution at the inlet than would be the case if angle of attack were included, as suggested in this report.)

As mentioned in the Design Inputs section, the method can also proceed from shroud to hub by making the sign of  $\Delta n$  in equation (13) negative and by prescribing conditions along the shroud. Adjustment of conditions on the shroud similar to those done to the hub can produce an acceptable hub and hub velocity distribution. The shroud contour and velocity distribution computed as the first trial (figs. 7(a) and (b)) were used as input to the program to illustrate starting on the shroud and the computed hub and hub velocity distribution, as shown in figures 7(a) and (b), are almost identical with the original prescribed hub and hub velocities.

In choosing the number of stations for a solution, some care should be exercised to avoid very small spacings especially in regions of large curvature in order to prevent numerical difficulties that become increasingly worse as the solution proceeds toward the shroud. The reason is that the spacing gets smaller near the shroud and may become of the same order of magnitude as the error in the numerical procedures, or the spacing may become negative. In either case, the solution becomes meaningless in such a region.

A sufficient number of streamlines should be chosen so that the resulting  $\Delta n$  is small enough to make the assumption of constant  $a$  and  $b$  in equation (2) a valid one. The value of  $\Delta n$  varies with the size of the impeller and can usually be determined in one or two trials. It is probably not worth starting with less than 10 streamlines. Limited experience indicates that no difficulties result from having too many streamlines; however, it is a waste of time to have more than necessary for the degree of accuracy desired. In the numerical example presented, the results of the solution from the shroud to the hub indicate that  $\Delta n$  was chosen small enough to make the assumption of constant  $a$  and  $b$  satisfactory.

Lewis Research Center

National Aeronautics and Space Administration  
Cleveland, Ohio, September 19, 1962

## APPENDIX A

### SYMBOLS

A	area of stream tube normal to through flow
a	geometric parameter, eq. (3)
B	blade-shape parameter, eq. (B16)
b	geometric parameter, eq. (4)
$f_s$	slip factor
g	acceleration due to gravity
H	absolute total head, $h + V^2/2g$
$\Delta H$	head rise across pump
$H_{rel}$	relative total head, $h + W^2/2g$
h	static head
$h^*$	static head on surface S
$\Delta h$	$h_d - h_t$
J	number of stations
K	number of streamlines
M	number of blades
m	distance along meridional streamline
n	distance along normal to meridional streamline
$\Delta n$	normal distance between adjacent meridional streamlines
Q	volume flow rate through pump
$\Delta Q$	volume flow rate through annular stream tube
r	radial distance from axis of rotation
$r_c$	radius of curvature of meridional streamline



S stream-surface function and surface itself  
 t time  
 $t_n$  blade thickness normal to mean blade surface  
 $t_\theta$  blade thickness in circumferential direction  
 V absolute fluid velocity  
 W fluid velocity relative to rotating impeller  
 z axial distance from impeller inlet  
 $\alpha$  angle meridional streamline makes with impeller axis,  $\tan^{-1} dr/dz$   
 $\beta$  angle between streamline of surface S and its meridional projection,  
 $\tan^{-1} r d\theta/dm$   
 $\eta$  hydraulic efficiency  
 $\theta$  angular distance from radial line rotating with impeller, radians  
 $\Delta\theta$   $\theta_t - \theta_d$   
 $\lambda$  prewhirl,  $r_i(V_\theta)_i$   
 $\omega$  rotative speed of impeller

Subscripts:

av average between hub and shroud  
 d driving surface of blade  
 h hub  
 i impeller inlet  
 j index for stations along meridional streamline  
 m meridional component  
 r radial component  
 s shroud  
 t trailing surface of blade

- z axial component
- $\theta$  circumferential component
- 1 known streamline
- 2 adjacent unknown streamline

## APPENDIX B

### DERIVATION OF VELOCITY EQUATION

The objective in this appendix is to derive a simplified relation between the known relative velocity on some known streamline and the unknown relative velocity on an adjacent streamline. Other quantities involved in the relation are certain properties of the known streamline and the impeller blade geometry.

The starting point is the equations of motion governing the steady relative three-dimensional incompressible nonviscous flow at any point in a turbomachine (ref. 4):

$$\frac{dW_r}{dt} - \frac{(W_\theta + \omega r)^2}{r} = W_r \frac{\partial W_r}{\partial r} + \frac{W_\theta}{r} \frac{\partial W_r}{\partial \theta} + W_z \frac{\partial W_r}{\partial z} - \frac{(W_\theta + \omega r)^2}{r} = -g \frac{\partial h}{\partial r} \quad (\text{B1a})$$

$$\frac{1}{r} \frac{drV_\theta}{dt} = \frac{dW_\theta}{dt} + \frac{W_r W_\theta}{r} + 2\omega W_r = W_r \frac{\partial W_\theta}{\partial r} + \frac{W_\theta}{r} \frac{\partial W_\theta}{\partial \theta} + W_z \frac{\partial W_\theta}{\partial z} + \frac{W_r W_\theta}{r} + 2\omega W_r = -\frac{g}{r} \frac{\partial h}{\partial \theta} \quad (\text{B1b})$$

$$\frac{dW_z}{dt} = W_r \frac{\partial W_z}{\partial r} + \frac{W_\theta}{r} \frac{\partial W_z}{\partial \theta} + W_z \frac{\partial W_z}{\partial z} = -g \frac{\partial h}{\partial z} \quad (\text{B1c})$$

where  $V_\theta = W_\theta + \omega r$ ,  $h$  is static head in feet of fluid and  $r$ ,  $\theta$ , and  $z$  are cylindrical coordinates relative to the rotating impeller (see sketch).

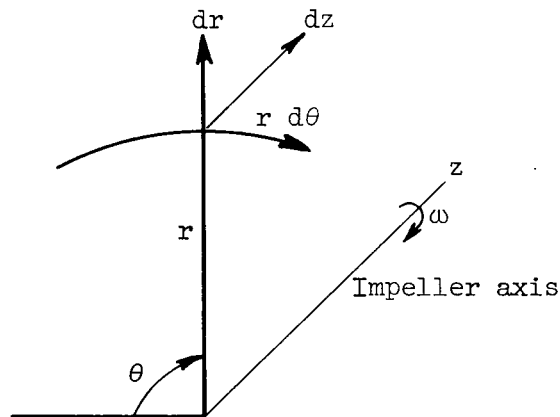

The problem can be reduced from three dimensions to two dimensions by first considering a relative stream surface  $S$  (fig. 2) that extends from hub to shroud

about midway between blades. (This is a surface of the second kind in the terminology of ref. 4.) For steady relative flow, such a surface is a three-dimensional surface that rotates with the impeller and is given by a relation among the coordinates of the form

$$S(r, \theta, z) = 0$$

or solving for  $\theta$

$$\theta = \theta(r, z) \quad (B2)$$

This equation is used to relate the static head  $h$  of the three-dimensional flow field with the static head  $h^*$  on the surface  $S$ . In general,

$$h = h(r, \theta, z) \quad (B3)$$

but on the surface  $S$

$$h^* = h[r, \theta(r, z), z] = h^*(r, z) \quad (B4)$$

since  $\theta$  on the surface is not an independent variable. The relation between partial derivatives of the static head in the three-dimensional field with those on the surface  $S$  is given by

$$\left. \begin{aligned} \frac{\partial h^*}{\partial r} &= \frac{\partial h}{\partial r} + \frac{\partial h}{\partial \theta} \frac{\partial \theta}{\partial r} \\ \frac{\partial h^*}{\partial z} &= \frac{\partial h}{\partial z} + \frac{\partial h}{\partial \theta} \frac{\partial \theta}{\partial z} \end{aligned} \right\} \quad (B5)$$

Substitution of equations (B5) in equations (B1) yields

$$\frac{dW_r}{dt} - \frac{(W_\theta + \omega r)^2}{r} = -g \frac{\partial h^*}{\partial r} + gr \frac{\partial \theta}{\partial r} \frac{1}{r} \frac{\partial h}{\partial \theta} \quad (B6a)$$

$$\frac{1}{r} \frac{drV_\theta}{dt} = \frac{dW_\theta}{dt} + \frac{W_r W_\theta}{r} + 2\omega W_r = -\frac{g}{r} \frac{\partial h}{\partial \theta} \quad (B6b)$$

$$\frac{dW_z}{dt} = -g \frac{\partial h^*}{\partial z} + gr \frac{\partial \theta}{\partial z} \frac{1}{r} \frac{\partial h}{\partial \theta} \quad (B6c)$$

Equations (B6) are seen to be the same as Lorenz's equations for axially symmetric flow (ref. 9, p. 991) with a blade force (appendix B of ref. 1). Instead of assuming axial symmetry, however, the equations are written for flow on a stream surface  $S$ . And instead of introducing the concept of blade force and having blade-force components in the equations, the circumferential pressure gradient  $\frac{1}{r} \frac{\partial h}{\partial \theta}$  appears in all three equations.

Equation (B6b) can be used to eliminate the circumferential pressure gradient from equations (B6a) and (B6c) giving

$$\frac{dW_r}{dt} - \frac{V_\theta^2}{r} = -g \frac{\partial h^*}{\partial r} - r \frac{\partial \theta}{\partial r} \left( \frac{1}{r} \frac{drV_\theta}{dt} \right) \quad (B7a)$$

$$\frac{dW_z}{dt} = -g \frac{\partial h^*}{\partial z} - r \frac{\partial \theta}{\partial z} \left( \frac{1}{r} \frac{drV_\theta}{dt} \right) \quad (B7b)$$

The remaining two equations involve known geometry, flow properties on the surface  $S$ , and their derivatives in the  $r$ - and  $z$ -directions only. The mathematical significance here is that the problem can be considered in the  $r$ -,  $z$ - or meridional plane. If attention is further limited to a streamline of the surface and its projection in the meridional plane, then  $r$  and  $z$  are related, and equations (B7) can be reduced to one equation. The projection of a streamline of  $S$  onto the meridional plane is called the meridional streamline (fig. 4) and the velocity in the direction of this streamline is called the meridional or through-flow velocity  $W_m$ . The velocity components  $W_r$  and  $W_z$  are related to each other and to  $W_m$  by the angle  $\alpha$ , which is the angle between the pump axis and a tangent to the meridional streamline (fig. 3). Along the streamline,  $r = r(z)$ , and  $\alpha$  is obtained from

$$\alpha = \tan^{-1} \frac{dr}{dz} \quad (B8)$$

The velocity components  $W_r$  and  $W_z$  can be expressed in terms of  $W_m$  and  $\alpha$  to yield (fig. 3)

$$W_r = W_m \sin \alpha$$

$$W_z = W_m \cos \alpha$$

Differentiation yields

$$\left. \begin{aligned} \frac{dW_r}{dt} &= W_m \cos \alpha \frac{d\alpha}{dt} + \frac{dW_m}{dt} \sin \alpha \\ \frac{dW_z}{dt} &= -W_m \sin \alpha \frac{d\alpha}{dt} + \frac{dW_m}{dt} \cos \alpha \end{aligned} \right\} \quad (B9)$$

The quantity  $d\alpha/dt$  can be eliminated from equations (B9) by making use of the curvature of the meridional streamline

$$\frac{1}{r_c} = \frac{d\alpha}{dm} = \frac{\frac{d\alpha}{dt}}{\frac{dm}{dt}} = \frac{1}{W_m} \frac{d\alpha}{dt}$$

Making use of this relation and combining equations (B7) and (B9) yields

$$\frac{W_m^2}{r_c} \cos \alpha + \frac{dW_m}{dt} \sin \alpha - \frac{V_\theta^2}{r} = -g \frac{\partial h^*}{\partial r} - r \frac{\partial \theta}{\partial r} \frac{1}{r} \frac{drV_\theta}{dt} \quad (\text{B10a})$$

$$-\frac{W_m^2}{r_c} \sin \alpha + \frac{dW_m}{dt} \cos \alpha = -g \frac{\partial h^*}{\partial z} - r \frac{\partial \theta}{\partial z} \frac{1}{r} \frac{drV_\theta}{dt} \quad (\text{B10b})$$

The next step is to combine  $\partial h^*/\partial r$  and  $\partial h^*/\partial z$  and reduce equations (B10) to one equation. To this end, take the directional derivative of  $h^*$  in the direction normal to the meridional streamline, that is, in the direction  $\alpha + 90^\circ$ , and call the distance in this direction  $n$ . Then

$$\frac{dh^*}{dn} = \frac{\partial h^*}{\partial r} \frac{dr}{dn} + \frac{\partial h^*}{\partial z} \frac{dz}{dn} \quad (\text{B11})$$

But from figure 3

$$\frac{dz}{dn} = \cos(\alpha + 90^\circ) = -\sin \alpha \quad (\text{B12})$$

$$\frac{dr}{dn} = \sin(\alpha + 90^\circ) = \cos \alpha \quad (\text{B13})$$

and equation (B11) can be written

$$g \frac{dh^*}{dn} = g \frac{\partial h^*}{\partial r} \cos \alpha - g \frac{\partial h^*}{\partial z} \sin \alpha \quad (\text{B14})$$

Multiply equation (B10a) by  $\cos \alpha$  and (B10b) by  $\sin \alpha$  and combine them to obtain

$$g \frac{dh}{dn} = \frac{V_\theta^2 \cos \alpha}{r} - \frac{W_m^2}{r_c} + \frac{B}{r} \frac{drV_\theta}{dt} \quad (\text{B15})$$

where, for convenience,  $B$  is defined as

$$B \equiv r \frac{\partial \theta}{\partial z} \sin \alpha - r \frac{\partial \theta}{\partial r} \cos \alpha \quad (\text{B16})$$

and where  $h$  has been written for  $h^*$  since there is no longer any need to distinguish between them. Equation (B15) is usually called the force equation. The dimensions of its terms are those of acceleration or force per unit mass. The left side is the total force on a particle in the direction normal to the meridional streamline. The first term on the right is the normal component of the centrifugal force due to rotation about the axis of the impeller, the second

term is centrifugal force due to curvature of the meridional streamline, and the third term is the normal component of the force due to the circumferential pressure gradient. At first, it may appear that there should be no component of circumferential pressure gradient in the meridional plane since the circumferential direction is normal to the meridional plane. It must be remembered, however, that the meridional plane is not a physical plane in which the flow takes place but is a computational tool that permits visualization of the through flow. The normal component of the circumferential pressure gradient is the component along a line in the flow surface  $S$  of which the normal is the meridional projection. In general, in moving along a line in the flow surface,  $\theta$  will change so that there can be a component of the circumferential pressure gradient along such a line. (For straight blades, i.e., for  $\partial\theta/\partial z$  and  $\partial\theta/\partial r$  both zero, there is no component of the circumferential pressure gradient in the meridional plane.)

The velocity components  $W_\theta$  and  $W_m$  are related to each other and to the resultant velocity  $W$  through an angle  $\beta$  (fig. 4). This angle is often called the flow angle and is also the blade angle when the stream surface is parallel to the mean blade surface. It is the angle between a streamline of the surface  $S$  and its meridional projection. When the flow surface is a mean blade surface,  $\beta$  is known.

From figure 4, it can be seen that

$$W_m = W \cos \beta \quad (B17)$$

and

$$W_\theta = W \sin \beta \quad (B18)$$

Making use of relations (B16), (B17), and (B18) (and certain derivatives and identities), equation (B15) can be written in a more useful form:

$$g \frac{dh}{dn} = \frac{-W^2 \cos^2 \beta}{r_c} + \frac{(W \sin \beta + \omega r)^2}{r} \cos \alpha + BW \cos \beta \left( \frac{dW_\theta}{dm} + \frac{W \sin \beta \sin \alpha}{r} + 2\omega \sin \alpha \right) \quad (B19)$$

Since an equation in  $W$  only and not  $h$  is desired, another relation between  $h$  and  $W$  is needed. Such a relation can be obtained from a different manipulation of the equations of motion, which is equivalent to writing an energy equation along a streamline.

Multiply equation (Bl a) by  $W_r = \frac{dr}{dt}$ , equation (Bl b) by  $W_\theta = r \frac{d\theta}{dt}$ , and equation (Bl c) by  $W_z = \frac{dz}{dt}$  and add and combine terms to obtain

$$\frac{1}{2} \frac{dW^2}{dt} - \omega^2 r W_r = -g \frac{dh}{dt} \quad (\text{B20})$$

Integrate equation (B20) along a streamline between the pump inlet and any station to obtain

$$\frac{1}{2} (W^2 - W_i^2) - \frac{\omega^2}{2} (r^2 - r_i^2) = -g(h - h_i) \quad (\text{B21})$$

Since  $W^2 = V^2 - 2V_\theta \omega r + \omega^2 r^2$  and  $H = h + \frac{V^2}{2g}$  where  $H =$  total head, equation (B21) can be written

$$h = H_i - \frac{W^2}{2g} + \frac{\omega^2 r^2}{2g} - \frac{\omega \lambda}{g} \quad (\text{B22})$$

where instead of  $r_i(V_\theta)_i$ ,  $\lambda$  has been written, which is commonly called prewhirl. The prewhirl is a function of the upstream conditions and is usually specified for the pump designer.

Take the directional derivative of  $h$  in the direction of  $n$ , that is, the direction normal to the meridional streamline to obtain

$$\frac{dh}{dn} = \frac{dH_i}{dn} - \frac{W}{g} \frac{dW}{dn} + \frac{\omega^2 r}{g} \frac{dr}{dn} - \frac{\omega}{g} \frac{d\lambda}{dn} \quad (\text{B23})$$

Equation (B23) can be used to eliminate  $dh/dn$  from equation (Bl9) with the result that

$$\begin{aligned} \frac{dW}{dn} = & W \left( \frac{\cos^2 \beta}{r_c} - \frac{\sin^2 \beta \cos \alpha}{r} - \frac{B \cos \beta \sin \beta \sin \alpha}{r} \right) - 2\omega \sin \beta \cos \alpha \\ & - B \cos \beta \left( \frac{dW_\theta}{dn} + 2\omega \sin \alpha \right) + \frac{g}{W} \frac{dH_i}{dn} - \frac{\omega}{W} \frac{d\lambda}{dn} \end{aligned} \quad (\text{B24})$$



For convenience, define the quantities  $a$  and  $b$  so that

$$a = \frac{\cos^2 \beta}{r_c} - \frac{\sin^2 \beta \cos \alpha}{r} - \frac{B \cos \beta \sin \beta \sin \alpha}{r} \quad (\text{B25})$$

and

$$b = 2\omega \sin \beta \cos \alpha + B \cos \beta \left( \frac{dW_\theta}{dm} + 2\omega \sin \alpha \right) - \frac{g}{W} \frac{dH_i}{dn} + \frac{\omega}{W} \frac{d\lambda}{dn} \quad (\text{B26})$$

Put these into equation (B24) to obtain the velocity equation

$$\frac{dW}{dn} = aW - b \quad (\text{B27})$$

This equation together with a suitable form of the continuity equation enables the designer to compute the coordinates of any streamline of the surface  $S$  and its velocity distribution provided that the stream surface is known or prescribed and some streamline of the surface together with its velocity distribution is known or prescribed (boundary condition). Furthermore, the static head on the surface can be computed from equation (B22). The total head  $H$  can be found by putting  $h = H - \frac{V^2}{2g}$  in equation (B22) which gives, after some manipulation,

$$H = H_i + \frac{\omega r V_\theta}{g} - \frac{\omega \lambda}{g} = H_i + \frac{\omega r W_\theta}{g} + \frac{\omega^2 r^2}{g} - \frac{\omega \lambda}{g} \quad (\text{B28})$$

## APPENDIX C

### EQUATION FOR BLADE SURFACE VELOCITY AND HEAD RISE

With further simplifying assumptions, the approximate velocity and head on the blade surfaces can be computed. The static-head derivative in the circumferential direction, that is, from blade to blade, is given by equation (B1b):

$$\frac{1}{r} \frac{drV_\theta}{dt} = \frac{dW_\theta}{dt} + \frac{W_r W_\theta}{r} + 2\omega W_r = W_r \frac{\partial W_\theta}{\partial r} + \frac{W_\theta}{r} \frac{\partial W_\theta}{\partial \theta} + W_z \frac{\partial W_\theta}{\partial z} + \frac{W_r W_\theta}{r} + 2\omega W_r = -\frac{g}{r} \frac{\partial h}{\partial \theta}$$

Making use of relations among velocity components and angles, the previous equation becomes

$$W \cos \beta \left( \frac{dW_\theta}{dm} + \frac{W}{r} \sin \beta \sin \alpha + 2\omega \sin \alpha \right) = -\frac{g}{r} \frac{\partial h}{\partial \theta} \quad (C1)$$

If a linear variation in static head from blade to blade in the circumferential direction (i.e., along a path of constant  $z$  and  $r$ ) is assumed,

$$\frac{1}{r} \frac{\partial h}{\partial \theta} = \frac{-\Delta h}{r \Delta \theta} \quad (C2)$$

where

$$-\Delta h = h_t - h_d$$

and

$$r \Delta \theta = r(\theta_t - \theta_d) = \frac{2\pi r - Mt_\theta}{M}$$

where  $t_\theta$  is the blade thickness in the circumferential direction.

Combine equations (C1) and (C2) and solve for  $\Delta h$  to obtain

$$\Delta h = \frac{1}{g} \left( \frac{2\pi r - Mt_\theta}{M} \right) W \cos \beta \left( \frac{dW_\theta}{dm} + \frac{W}{r} \sin \beta \sin \alpha + 2\omega \sin \alpha \right) \quad (C3)$$

If the static head  $h$  (eq. (B22)) evaluated on the surface  $S$  is assumed to be the average between blades,

$$h = \frac{h_d + h_t}{2} = h_d - \frac{\Delta h}{2} = h_t + \frac{\Delta h}{2}$$

which gives

$$h_d = h + \frac{\Delta h}{2} \quad (C4)$$

and

$$h_t = h - \frac{\Delta h}{2} \quad (C5)$$

The relative velocity on the blade surface can be computed by making use of the relative total head,  $H_{rel}$ :

$$H_{rel} = h + \frac{W^2}{2g}$$

Put this relation in equation (B22) to obtain

$$H_{rel} = H_i + \frac{\omega^2 r^2}{2g} - \frac{\omega \lambda}{g}$$

If  $H_i$  and  $\lambda$  are not functions of  $\theta$ , at constant  $r$ ,  $H_{rel}$  is constant and

$$h + \frac{W^2}{2g} = h_d + \frac{W_d^2}{2g} = h_t + \frac{W_t^2}{2g}$$

so that

$$W_d = \sqrt{W^2 - g \Delta h} \quad (C6)$$

and

$$W_t = \sqrt{W^2 + g \Delta h} \quad (C7)$$

In equation (C6), if  $W^2 - g \Delta h$  is negative,  $W_d$  is imaginary; however,  $W_d$  is interpreted as being negative, which indicates an eddy on the driving surface of the blade. In reference 6, results obtained by this method were compared with an exact blade-to-blade solution of a case with an eddy. The present method (which interprets the imaginary  $W_d$  as negative) did indicate the eddy, but it somewhat exaggerated the magnitude of the negative velocities.

## REFERENCES

1. Hamrick, Joseph T., Ginsburg, Ambrose, and Osborn, Walter M.: Method of Analysis for Compressible Flow Through Mixed-Flow Centrifugal Impellers of Arbitrary Design. NACA Rep. 1082, 1952. (Supersedes NACA TN 2165.)
2. Smith, Kenneth J., and Hamrick, Joseph T.: A Rapid Approximate Method for the Design of Hub Shroud Profiles of Centrifugal Impellers of Given Blade Shape. NACA TN 3399, 1955.
3. Osborn, Walter M., Smith, Kenneth J., and Hamrick, Joseph T.: Design and Test of Mixed-Flow Impellers. VIII - Comparison of Experimental Results for Three Impellers with Shroud Redesigned by Rapid Approximate Method. NACA RM E56L07, 1957.
4. Wu, Chung-Hua: A General Theory of Three-Dimensional Flow in Subsonic and Supersonic Turbomachines of Axial-, Radial-, and Mixed-Flow Types. NACA TN 2604, 1952.
5. Kramer, James J., Stockman, Norbert O., and Bean, Ralph J.: Nonviscous Flow Through a Pump Impeller on a Blade-to-Blade Surface of Revolution. NASA TN D-1108, 1962.
6. Kramer, James J., Stockman, Norbert O., and Bean, Ralph J.: Incompressible Nonviscous Blade-to-Blade Flow Through a Pump Rotor with Splitter Vanes. NASA TN D-1186, 1962.
7. Stanitz, John D., and Prian, Vasily D.: A Rapid Approximate Method for Determining Velocity Distribution on Impeller Blades of Centrifugal Compressors. NACA TN 2421, 1951.
8. Scarborough, James B.: Numerical Mathematical Analysis. The Johns Hopkins Press, 1958.
9. Stodola, A.: Steam and Gas Turbines. Vol. II. McGraw-Hill Book Co., Inc., 1927. (Reprinted, Peter Smith (New York), 1945.)